

(NASA-CR-148539) ANALYSIS AND DESIGN OF A
CAPSULE LANDING SYSTEM AND SURFACE VEHICLE
CONTROL SYSTEM FOR MARS EXPLORATION
Progress Report, 1 Jul. 1975 - 30 Jun. 1976
Rensselaer Polytechnic Inst.

N76-28257
HC \$5.00

Unclas

77 p HC G3/14 47698

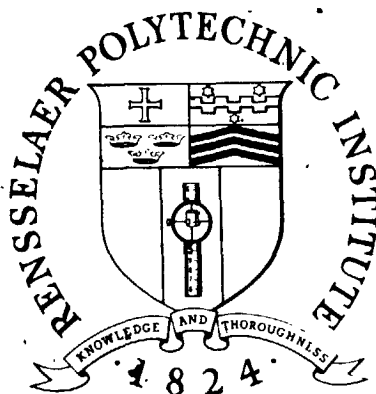
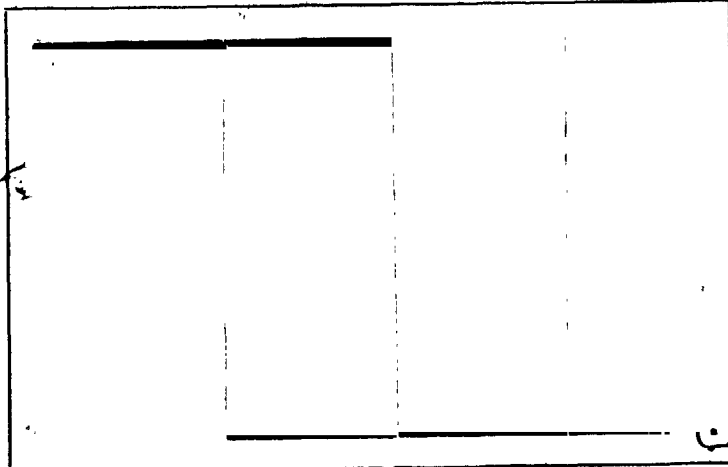

Rensselaer Polytechnic Institute

Troy, New York

R.P.I. TECHNICAL REPORT MP-49

A Progress Report for
July 1, 1975 to June 30, 1976

ANALYSIS AND DESIGN OF A CAPSULE
LANDING SYSTEM AND SURFACE VEHICLE
CONTROL SYSTEM FOR MARS EXPLORATION

National Aeronautics and Space
Administration

Grant NGL 33-018-981

Submitted by the Special Projects Committee

D. G. Gisser
D. K. Frederick
G. N. Sandor
C. N. Shen
S. W. Yerazunis

School of Engineering
Rensselaer Polytechnic Institute



ABSTRACT

Problems related to the design and control of an autonomous rover for the purpose of unmanned exploration of the planets have been considered. Building on the basis of prior studies, a four wheeled rover of unusual mobility and maneuverability has been further refined and tested under both laboratory and field conditions. A second major effort has been made to develop autonomous guidance. Path selection systems capable of dealing with relatively formidable hazard and terrains involving various short range (1.0-3.0 meters), hazard detection systems using a triangulation detection concept have been simulated and evaluated. The mechanical/electronic systems required to implement such a scheme have been constructed and tested. These systems include: laser transmitter, photodetectors, the necessary data handling/controlling systems and a scanning mast. In addition, a telemetry system to interface the vehicle, the off-board computer and a remote control module for operator intervention have been developed. Software for the autonomous control concept has been written. All of the systems required for complete autonomous control have been shown to be satisfactory except for that portion of the software relating to the handling of interrupt commands.

Further progress has been made in the area of wheel design and testing for fatigue and dynamic load failure. Alternative payload protection concepts have been studied and a proximity sensor concept has been examined in depth. Efforts have also continued in the area of advanced terrain sensing and obstacle detection concepts.

TABLE OF CONTENTS

	Page
INTRODUCTION.....	1
OVERVIEW OF THE PROJECT.....	2
SUMMARY OF RESULTS.....	2
DETAILED SUMMARIES OF PROGRESS.....	6
A. Vehicle Configuration, Control, Dynamics, Systems and Propulsion.....	6
A.1 Mechanical/Electronic Improvements.....	6
A.2 Terrain Sensor Scanning Mast.....	8
A.3 Vehicle Control Systems.....	10
A.4 Telemetry and Computer Interface.....	14
A.5 Computer Softer.....	14
A.6 Laboratory and Field Testing.....	18
A.7 Wheel Analysis.....	20
A.8 Payload Protection Systems.....	26
B. Terrain Sensing and Data Handling.....	31
B.1 Laser Transmitter/Receiver.....	31
B.2 Data Handler/Controller.....	34
C. Path Selection System Development and Evaluation.....	41
D. Advanced Terrain Sensing-Hazard Detection Concepts.....	54
REFERENCES.....	55
APPENDIX.....	57

INTRODUCTION

Current national goals in space exploration include a detailed exploration of the planet Mars. In the past, these investigations have employed remote sensing systems carried by fly-by vehicles and more recently orbiting devices. As of this writing, the Viking spacecraft are orbiting Mars with the objective of selecting a suitable landing site. On completion of the Viking missions, basic knowledge of biological, chemical and meteorological characteristics of the Mars surface will have been gained. Despite the monumental achievement which a successful Viking mission will represent, the limited zone of exploration as constrained by the ten foot sampling boom will not fulfill the long term scientific objectives. Ultimately, a rather more complete exploration of Mars and other suitable planets and extraterrestrial solar system bodies will be desired.

The major impediment to an unmanned mission of exploration is the long round-trip communication delay. For Mars, this delay varies from a minimum of about nine minutes to a maximum of approximately 45 minutes depending on the distance between Mars and Earth. For other missions, the delays are even longer. Thus, for a mission of any consequence in range and a reasonable duration in time, i.e., several hundred kilometers or more, it is not feasible to rely strictly on earth control to direct a vehicle or equivalent relocatable device from the original landing site to the desired sampling points. It follows that a roving vehicle possessing a high degree of automatism is essential to such missions.

In looking forward towards significant and detailed unmanned planetary exploration, it would appear that developmental activities should be aimed at two basic problems in order to permit either an augmented Viking mission or a sample return mission.

First, the vehicle should be characterized by a high level of mobility in order that reasonable paths be available to reach the desired targets. A vehicle of limited ability to deal with boulders, craters, crevasses, slope and other terrain irregularities may require an inordinate length of time and distance to reach the desired goal. Indeed in some circumstances, such a vehicle may not be able to reach the target. As the vehicle's mobility is increased, it will be able to deal with more difficult terrains. More paths will be available and the opportunity for selecting optimal paths will be increased.

Second, such a roving vehicle should be provided with a guidance and control system of comparable quality to its mobility. The decision as to which path should be followed must be made by a path selection system which is comprised of terrain sensor(s), a terrain modeler and a path selection algorithm. A low level path selection system will have to be biased conservatively to minimize the risk of an unperceived hazard. Thus, many and perhaps all acceptable paths may be excluded immobilizing the vehicle. The effect of a low level system is in fact to reduce the vehicle's mobility. As a minimum the path taken towards the desired goal will be lengthier and more time-consuming and the range of exploration will be reduced. On the other hand, a higher level, more sensitive and perceptive system will be able to detect a larger fraction of passable paths and select those most compatible with the mission and the vehicle.

This research program has been addressing these two major problems and other closely related issues with the goal of providing basic knowledge of long-term value to NASA and developing concrete alternatives applicable to future planetary exploration missions.

II. OVERVIEW OF THE PROJECT

During the past year the major emphasis has been directed to achieving, demonstrating and evaluating autonomous roving capability for the Rensselaer vehicle concepts. Figure 1, which was prepared in February of 1975, describes schematically the many sub-tasks and the time-frames required to achieve the goal of minimum autonomous control. Also shown in Figure 1 are several tasks related to higher level autonomous roving.

The major emphasis was directed towards the achievement of a minimum but total level of autonomous guidance and control towards a prescribed destination. Tasks included in this effort were those related to the vehicle, including communications, motion control, telemetry, computer software, wheel analysis, payload protection, and field testing, short range (1-3m) hazard detection, and path selection system development, simulation and evaluation based on the short range hazard detection concept. A lesser emphasis due to resource limitations was directed towards higher level path selection systems and specifically towards terrain modeling and obstacle detection in the 3-30 meter range. The latter effort was augmented in both scale and in scope by adding the 3-30 meter range path selection systems simulation task when an additional NASA Grant, NGL 7184, was approved.

All of the goals set on Figure 1 with the exception of the demonstration of complete closed loop autonomous control were achieved. Failure to achieve the final goal was due to incomplete software particularly with respect to the handling systems interrupts. Electro-mechanical systems including transmitters, receivers, data links, laser/photodetector scanners, on-board data handling/controlling, telemetry-computer interface, navigation and vehicle sensor data software and the path selection algorithm were completed and fully tested. The vehicle was upgraded mechanically and tested thoroughly both in laboratory and field situations. The hazard detection system was demonstrated to achieve the desired goals and appropriate signals were shown to be received at the offboard computer.

During the June-August period, work is continuing at a high level on the investigation of alternative path selection systems using higher level terrain detection schemes based on the laser/photodetector triangulation concept. It is intended to reactivate the hardware/software tasks this September with the goal of debugging the software and testing thoroughly the single laser/single detector concept in both laboratory and field situations. The next step would be to implement a higher level system which would probably involve elevation as well as azimuthal scanning of the laser and multiple photodetectors in order to gather sufficient data for more efficient path selection decision making.

III. SUMMARY OF RESULTS

TASK A. Vehicle Configuration, Control, Dynamics, Systems and Propulsion

This broad task was subdivided into a set of subtasks: mechanical/electronic improvement of the basic vehicle, design and construction of a scanning mast for terrain sensing, vehicle control systems, telemetry links including the computer interface between the vehicle and the off-board computer, computer software, laboratory and field testing, wheel analysis and payload protection systems.

A.1 Mechanical/Electronic Improvements

The basic vehicle design required little in the way of improvement of the

RENSELAER MARS PROJECT ASK ORGANIZATION AND MILESTONES (FEBRUARY 1975 - JULY 1976)

FEB. 1975

JULY 1975

JAN. 1976

JULY 1976

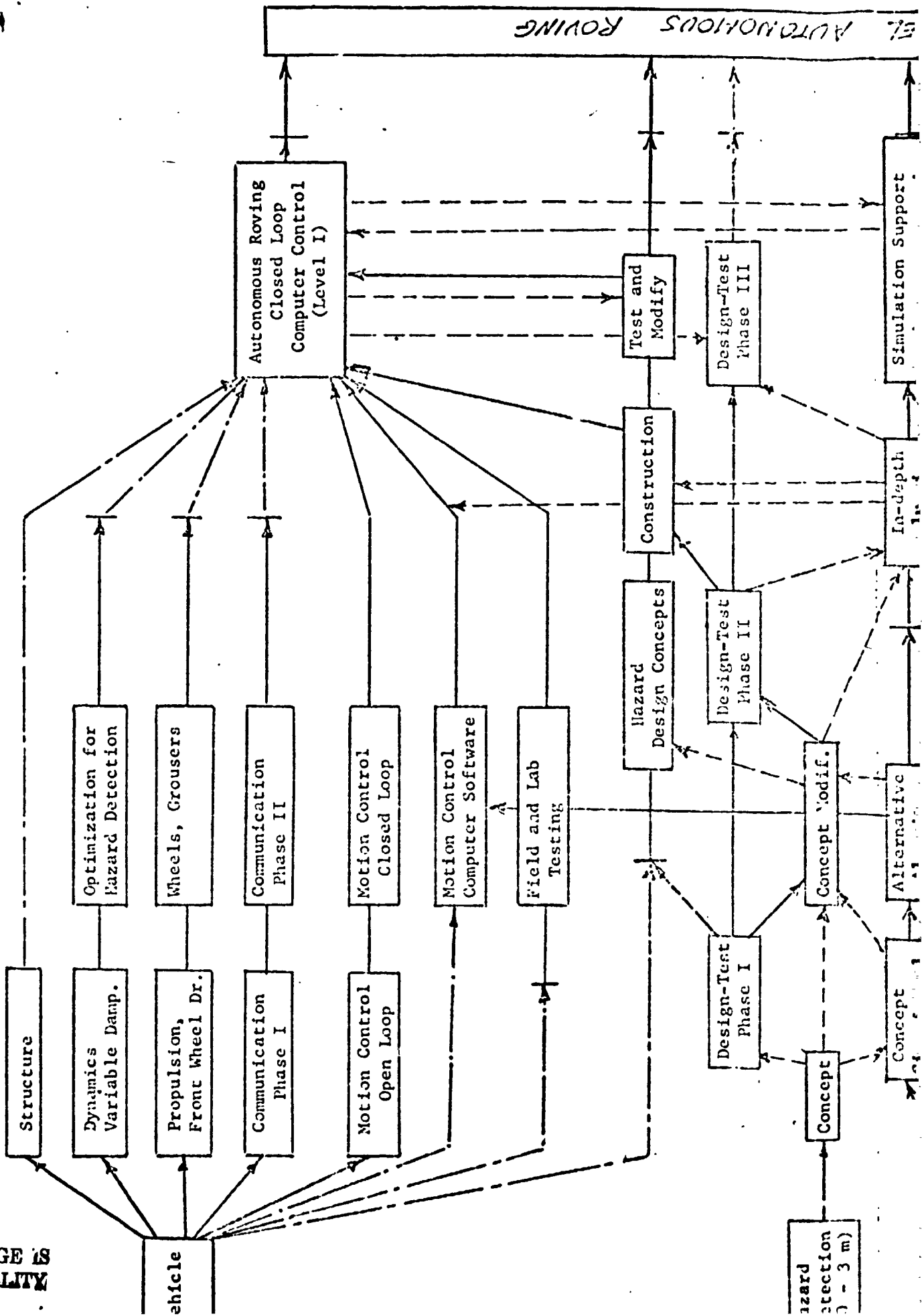

TOWARDS HIGHER LEVEL AUTONOMY

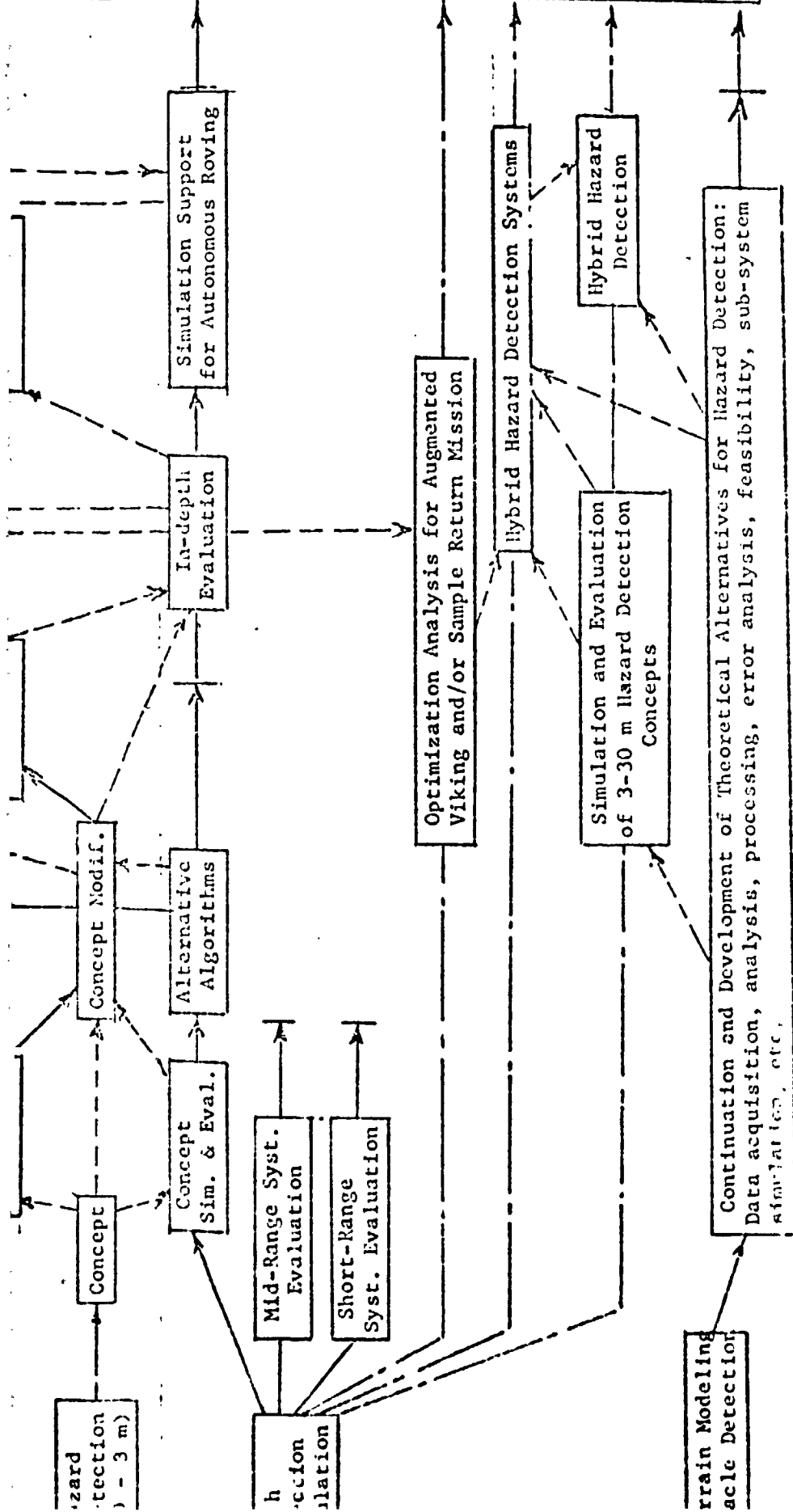

Figure 1. Kessler Mars Project Milestones to July 1976

existing mechanical/electronic components over the previous version. The front and assembly was reinforced and rear motor drive ratios were modified to provide increased torque at the wheels. A navigation gyro was added to the existing vehicle sensor system. The existing double-hoop toroidal wheels were stiffened to overcome the tendency for failure observed in extensive real terrain testing. A wheel tester to evaluate resistance to fatigue and/or dynamic load failure was designed and constructed.

A.2 Terrain Sensor Scanning Mast

On the basis of path selection system simulations, design requirements for a scanning mast on which to mount the terrain sensors were specified. A scanning mast meeting the requirements was designed, constructed, tested and installed on the vehicle. Field testing showed that the scanning mast met all operational requirements.

A.3 Vehicle Control Systems

A new four wheel speed control responding both to the vehicle speed command and to the steering requirements was developed. An improved steering control system was implemented using position feedback and pulse width modulation to drive the steering motor to one of fifteen preset steering angles. A system to monitor the directional gyro to allow it to track vehicle direction and transmit this data to the computer for navigation purposes was constructed. Control circuitry to maintain the scanning mast center parallel to the steering direction was also implemented.

A.4 Telemetry and Computer Interface

A telemetry system interfacing the vehicle, the computer and a manual station (Remote Control Module) was designed, constructed and tested. The system provides for high rate data transmission of hazard detection and vehicle data to the computer and for lower data rate transmission from either the computer or the Remote Control Module with the latter having override capabilities. The interface between the computer-related telemetry receiver/transmitter and the Varian/620i IDIOM Interactive Graphics Computer System was designed, constructed and tested.

A.5 Computer Software

Software was developed for the Varian/620i IDIOM Interactive Graphics Computer System for the control and guidance of the Rensselaer autonomous rover. Included in the software development were programs: to display graphically all pertinent vehicle strut, attitudinal and directional parameters as sensed by detectors; to display pertinent data such as speed, steering angle, etc.; to make necessary navigation computations as required by the path selection algorithm; to process hazard detection system signals to required form; to execute the path selection algorithm; and to issue steering and speed commands to the vehicle. All software developed proved to be effective except for those portions dealing with interrupts.

A.6 Laboratory and Field Testing

The vehicle's ability to deal with a variety of terrain features was tested in both laboratory and real terrain situations. The laboratory testing which

involved an obstacle "course" permitted quantitative conclusions. Although real terrain testing could not be reduced to quantitative parameters, the vehicle's real terrain performance far exceeded laboratory predictions. A considerable film footage documenting the vehicle's real terrain performance was taken and is now in process of being edited.

A.7 Wheel Analysis

A detailed review of the literature with respect to locomotion theory and measurement was completed and has provided a qualitative basis for improving the wheel design. Experimental measurements of force/deflection characteristics of single hoops in combination with the full range of stiffening spokes and with various angular force/hoop geometrics and of full wheels with and without grousers were made. On the basis of these data, an empirical design procedure relating the desired wheel footprint to the hoop parameters was obtained.

A.8 Payload Protection Systems

The problem of protecting the vehicle payload from terrain features which would be undetected by the path selection system was considered and several alternative systems were identified. The most promising of these involves light emitting diode/photodetector devices. In depth experimental studies were undertaken to determine the effect of the surface characteristics and orientation relative to the detector on the received signal. These data can now be used to design, construct and evaluate an optically-based payload protection system.

TASK B. Triangulation-Based Terrain Sensing

B.1 Laser Transmitter/Receiver

The laser transmitter required to implement a short range (1.0-3.0m) triangulation-based hazard detection was designed, constructed and tested. A laser detector and associated optics has also been constructed. The transmitter and detector systems have been mounted on the scanning mast and have been tested in concert with the data handler/controller system (Task B.2) and the telemetry system. The overall system has been demonstrated as meeting the specified requirements with appropriate detection signals being received at the computer site.

B.2 Data Handler/Controller

A data handler/controller intended to direct the operation of the terrain sensing system and to process data prior to transmission has been designed, constructed and tested. It meets the requirements of the basic one laser/one detector terrain sensing system but it can satisfy a three laser/five detector system.

TASK C. Path Selection System Simulation and Evaluation

Path selection systems employing a short range (1.0-3.0m) terrain sensing devices based on a triangulation concept have been conceived and evaluated by simulation. One and two laser/one detector system are shown to be effective for path selection in situations where basic terrain gradients are less than $\pm 12^\circ$ and where positive or negative hazards are defined as exceeding ± 12 inches. A three laser/three detector system has been shown capable of dealing effectively with more

severe terrain gradients.

TASK D. Advanced Terrain Sensing-Hazard Detection Concepts

The Rapid Estimation Scheme used in conjunction with a Kalman filter for the detection of discrete obstacles has been simulated on the Varian/6201 IDIOM Interactive Graphics Computer System. This program provides the basis for more effective investigation and evaluation of this edge enhancement technique in its application to path selection systems for planetary exploration.

IV. DETAILED SUMMARIES OF PROGRESS

TASK A. Vehicle Configuration, Control, Dynamics, Systems and Propulsion

The objectives of this task are two-fold: (a) to design, construct and evaluate a data and sample gathering rover to augment a second generation Viking lander or to support a sample return mission for an extensive Mars exploration, and (b) to provide a test bed for the rigorous evaluation of alternative hazard detection and path selection systems for an autonomous rover.

A.1 Mechanical/Electronic Improvements - P. Marino
Faculty Advisor: Prof. G. N. Sandor

Laboratory and field testing indicated that the front end assembly was marginal in mechanical strength. This is due to the vehicle's current weight of 260# as compared to 180# in 1973 when the basic structural frame was designed. The assembly was reinforced to meet the higher stress requirements.

Laboratory and field testing also disclosed that the rear motors were not providing sufficient torque, partly because of increased vehicle weight. As a result the mobility capabilities of the vehicle concept were not being optimized. The rear motor drive ratios had been initially set to obtain relatively high vehicle speeds. In view of the current short range hazard detection concept being implemented, such speeds are inappropriate. Accordingly the rear motor drive ratios were changed to increase the delivered torque and achieve desired vehicle speeds.

A navigation gyro was added to the existing vehicle sensor system to provide the directional heading data required by the path selection system for autonomous roving. Data processing and control of the gyro is described under Task A.3.

The earlier extensive field testing also revealed that the existing double hoop toroidal wheels were prone to failure under the severe dynamic evading encountered. The wheels were stiffened both radially and laterally by the addition of stiffening spokes and by increasing the stiffness of the hoop spring steel. Although these actions reduced the footprint area somewhat, the wheels were found to tolerate very severe dynamic loads during recent field testing. The current design is not believed to be optimal and future decisions will be guided by operating experience and the results of the studies reported under Task A.7.

Partly as a result of these wheel failure problems, a wheel fatigue tester was built during spring semester, 1976, (see Figure 2.) This machine consists of a large (1.5m) diameter wheel loaded against and driven by a test vehicle wheel. A variable speed A.C. motor supplies the driving force. This simulates a wheel

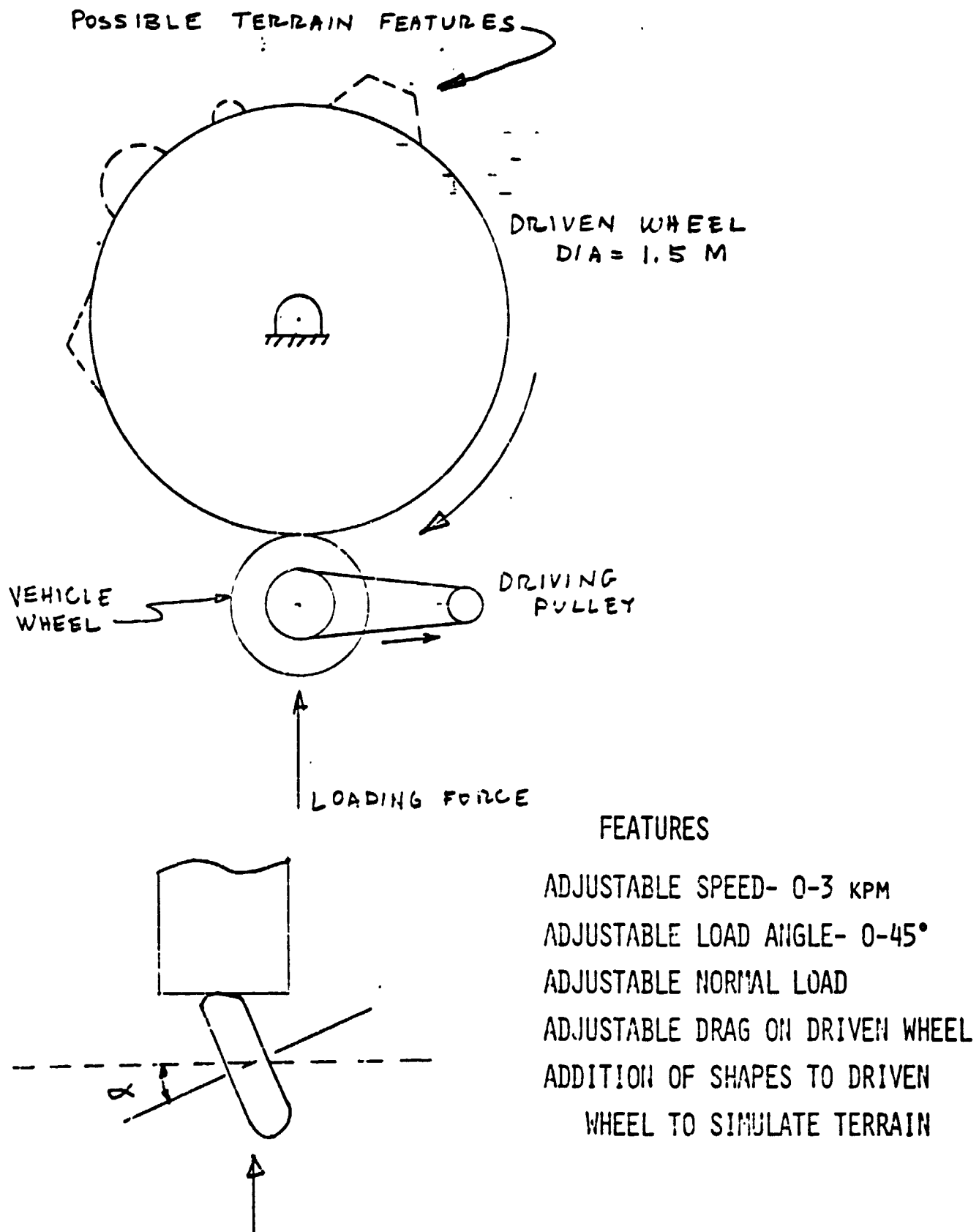

FIGURE 2. Wheel Fatigue and Dynamic Load Tester Details

running on the vehicle for extended periods of time, which would not be feasible without this machine. Features include variable speed, variable load angle, and variable load. In addition, rough terrain can be simulated by attaching "obstacles" to the large simulator wheel. Construction has just been completed, and comprehensive wheel testing is scheduled for Fall 1976.

The recent extensive field testing, Task A.6 has revealed that the torsion bar system is marginal and must be strengthened, again the result of increased vehicle weight. In addition, it is suspected that other components and systems such as the front motor drives may be marginal. This situation is also partly due to the fact that the vehicle's demonstrated ability to deal with terrain features far exceeds original design goals. Thus much larger dynamic loads are being experienced. Future work will have to be directed to a careful examination and analysis of vehicle components to determine what changes would be appropriate to take full advantage of vehicle's mobility potential.

A.2 Terrain Sensor Scanning Mast - P. Marino
Faculty Advisor: Prof. G. N. Sandor

On the basis of the path selection systems simulation studies, Task C., a minimum system involving a single laser/single detector using triangulation was developed. The scanning mast specifications were defined to meet path selection requirements. These were:

1. 160° scan at a minimum of 2 cycles/sec.
2. center of scan must be movable at 2 RPM.
3. mast must be capable of handling several lasers and detectors whose total moment of inertia is the equivalent of 4.0 Kg mass at a radius of 5.0 cm.
4. the angular position of the mast relative to center of scan must be available as an electrical signal.
5. the angle of the center of the scan relative to the vehicle structure must be available as an electrical signal.
6. the entire assembly should be light in weight, consume little power and produce little vibration in vehicle structure.

A scanning mast meeting these requirements was designed, constructed and installed on the vehicle. The system involves two motors, one of which drives a crank to generate the oscillating motion while the other positions the center of the scan according to the steering angle using a feedback loop. Thus the scanned terrain is always consistent with the direction of motion of the front wheel assembly. Details of the mast are provided in Figure 3. The laser assembly is located inside the tube which is rotated to obtain the desired azimuthal scanning. The mirror at the top of the mast can be adjusted to provide the desired elevation angle for the laser beams. The detector is fixed in position by a clamp and its elevation angle is adjustable. This arrangement will allow evaluation of alternative geometrical arrangements. Should it be desired to increase the height of the laser, it is necessary only to replace the aluminum tube with one of an appropriate length.

Two potentiometers provide the required position data to control the position of the center of scan relative to the steering angle and the firing of the laser at the desired azimuthal angles. The scanning speed can be controlled to a maximum of

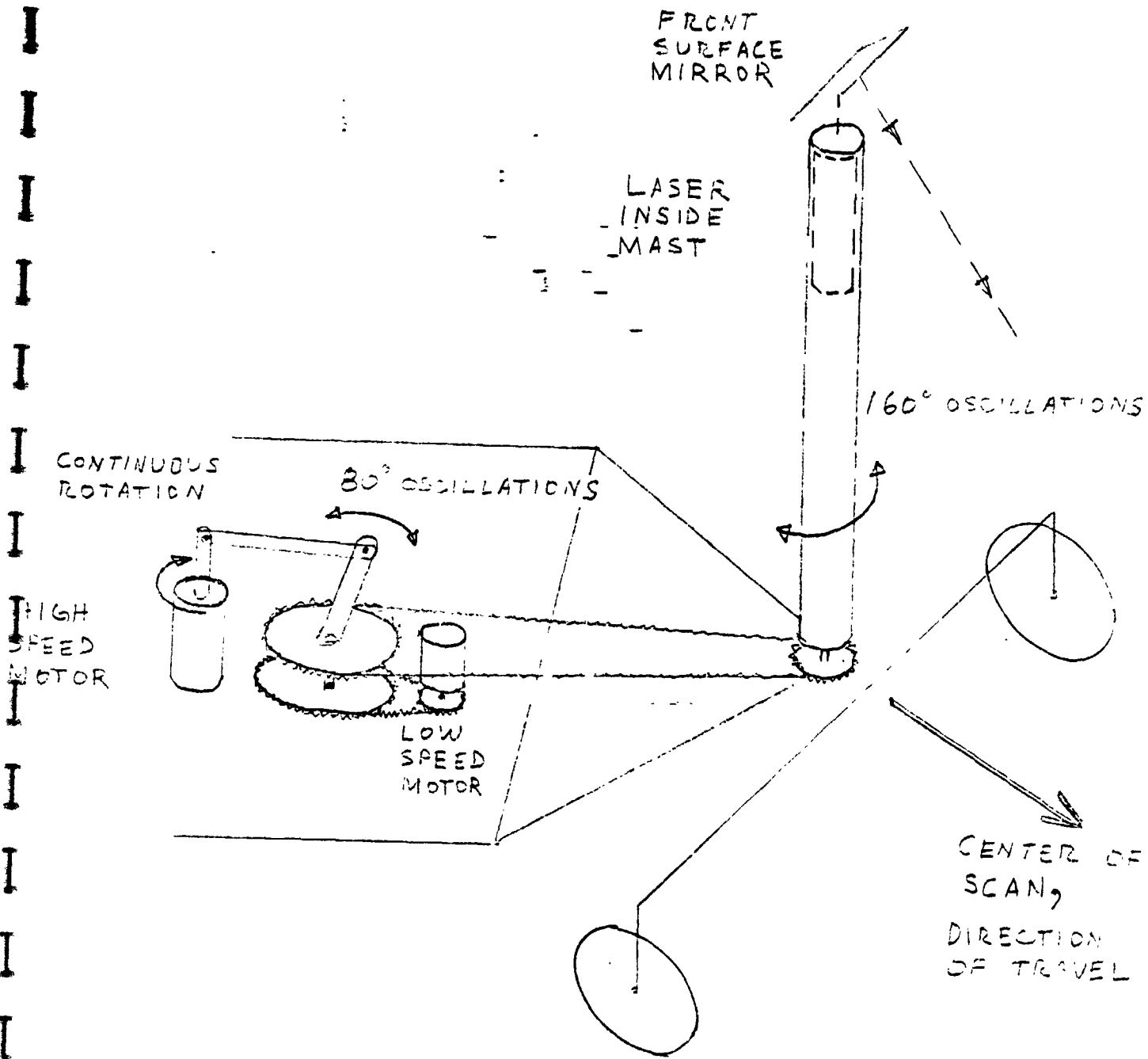

FIGURE 3. Scanning Mast System

five complete scans (i.e. 160° sweep and return to original position for a total of 320°) per second.

Should elevation as well as azimuthal scanning be desired, the fixed mirror can be replaced by a multifaced rotating mirror to achieve the desired elevation angle coverage. Multiple detectors can be attached to the scanning mast in many different ways. This mast fulfills current and anticipated short range hazard detection system requirements. As will be reported under Task B.2 the integrated scanning mast, laser-transmitter/receiver, data handler/controller and associated telemetry functioned as predicted.

A.3 Vehicle Control Systems - T. Geis, T. Kasura, J. Craig, W. Davis, T. Baran
Faculty Advisor: Prof. D. Gisser

Three major vehicle control systems tasks were addressed, namely, four wheel speed control, directional gyroscope monitoring and control, and scanning mast position and speed control.

The four wheel drive system is designed to monitor continuously the steering direction, the digital inputs derived from the tachometers, and to drive each wheel motor at the proper speed consistent with steering angle and vehicle speed. The system employs position feedback and pulse width modulation to drive the steering motor and bring the axle to one of fifteen preset steering angles.

The wheel speeds required as a function of steering angle were determined from the geometry of the system and are shown in Figure 4 as the continuous line. These wheel speed curves were normalized to obtain the discrete functions shown in Figure 4 by the dotted lines. A schematic of the overall system is shown in Figure 5. The wheel speed functions are stored permanently. At a particular steering angle, the appropriate functions are compared with actual wheel speed as determined by the tachometers to provide the required wheel speed.

A new steering system was also implemented. It involves analog position feedback and pulse width modulation to obtain 15 different preset steering angles. These steering angles, one in the center and seven equally spaced on each side give steering position from 0° to 90° in either direction. The control system is designed to produce a constant steering angle change rate when the difference between the actual and desired heading exceeds 5° and a linearly decreasing correction rate for a difference of less than 5° to minimize overshoot.

The directional gyroscope installed in the vehicle is a Giannini Type 3211 purchased as surplus equipment to reduce costs. Its only drawback is that the output potentiometer is linear over only 180° . Once past 90° from center, the gyro does not reflect changes in direction. To overcome this limitation, two solenoids mounted inside the gyro housing can be stepped in 2° intervals to keep the heading within the 180° range. A control system was designed to monitor the output voltages and step the solenoids in the proper direction while keeping track of the number of steps. The resulting directional gyro controller block diagram is shown in Figure 6.

Full details of these control systems are provided by Reference 1.

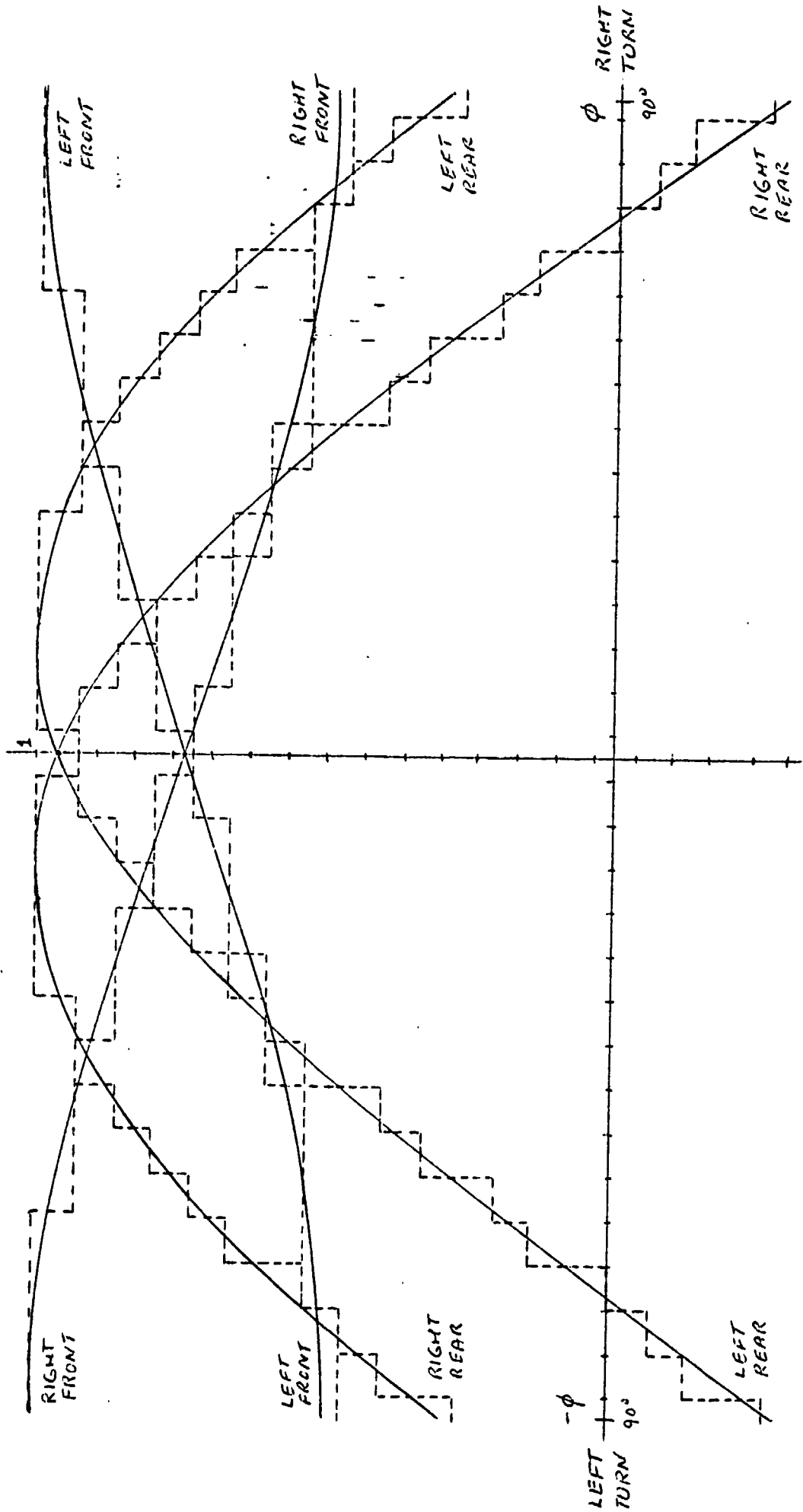

FIGURE 4 NORMALIZED WHEEL SPEED VERSUS ϕ GRAPH

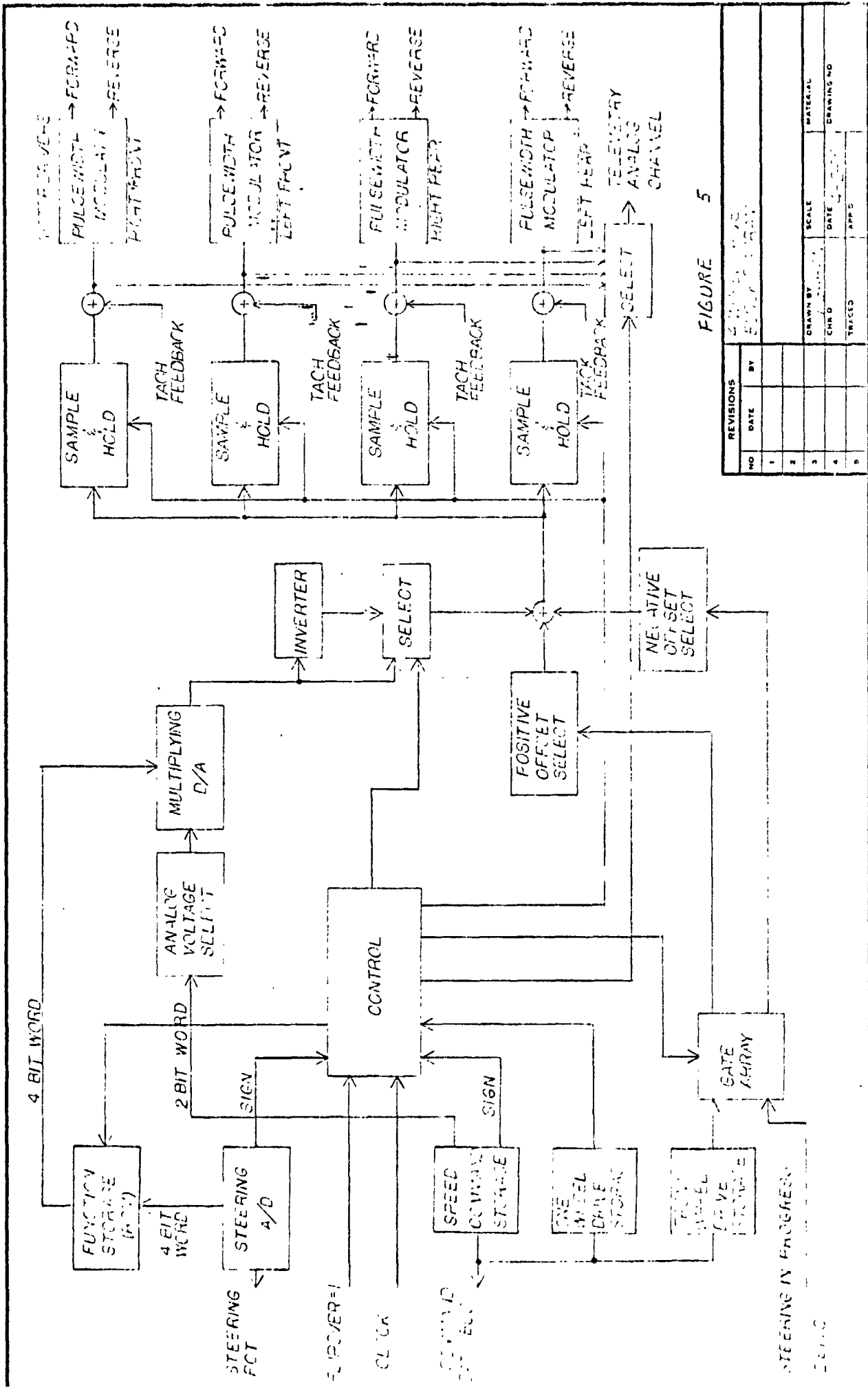

FIGURE 5

REVISIONS		DRAWN BY		SCALE		MATERIAL	
NO	DATE	BY				DATE	DRAWING NO
1							
2							
3							
4							
5							

STEERING IN PROGRESS
 2-11-60

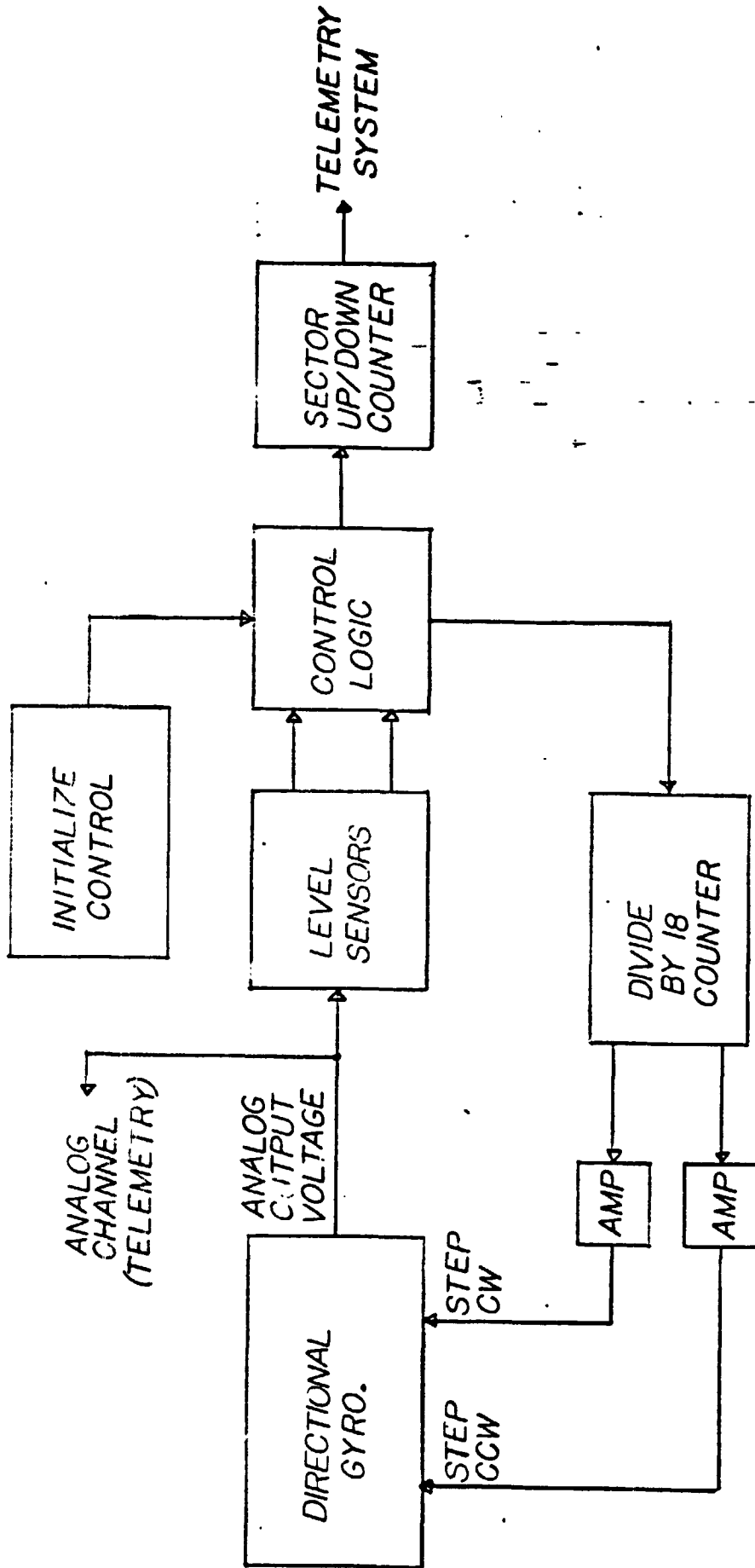

FIGURE 6. DIRECTIONAL GYRO CONTROLLER BLOCK DIAGRAM

A.4 Telemetry and Computer Interface - T.R. Geis, K. Fell, W. Davis,
D. Belanger, G. Hunt and T. Barone
Faculty Advisor: Prof. D. Gisser

The overall control system for the vehicle in the autonomous roving mode is shown in Figure 7. The telemetry requirements include a high data rate link from the vehicle to the telemetry receiver and two low data rate links from the computer command transmitter and the remote control module. In addition, a computer interface is required to accept the data transmitted by the vehicle and to control the transmission of command instructions to the vehicle.

Two major improvements in the telemetry system were made during the past period. First, the data link from the vehicle to the telemetry receiver was substantially upgraded to handle the new and future projected data rates. The system which is described in detail in Reference 2 can now handle 20 kilobits/sec and is designed to be upgraded to a 50 kilobit/sec rate with very modest modifications. The lower data rate capacity is substantially in excess of requirements anticipated for the short range hazard detection system concepts being implemented, (see Tasks B.1, B.2 and C). A Hamming code has been incorporated into the system to correct single errors and to detect multiple errors.

The second major improvement is in the remote control module which is used by the investigators on the test site to modify test objectives, i.e. vehicle speed or to override commands received from the computer command transmitter. Since complete closed loop control could not be achieved because of inoperative computer software systems, the remote control module was used to control the vehicle during the laboratory and field testing program. The new remote control module is compared with the old version in Figure 8. The major improvements were in the human/machine interface and involved a considerable improvement in the ability of the operator to specify his commands, Reference 1. The new design has increased capabilities to force the vehicle to address specific mobility tests. It will play an increasingly important role in future studies involving hazard detection by increasing the operator's ability to put the vehicle into desired encounters with potential hazard and observe the path selection systems response to these encounters.

A computer interface capable of receiving data transmitted by the vehicle or the control receiver and processing it as input to the computer and accepting computer output and processing it prior to transmission to the vehicle has been designed, constructed and tested. The overall role of the interface is shown in Fig. 9, in receiving and processing input data and commands and transmitting commands to the vehicle. In brief, the input interface performs four main operations: it outputs data to the computer in response to a SENSE command, handles Data Transfer In, Interrupts and DMA (direct memory addressing). The output interface handles Data Transfer Out routines. A detailed description of the interface including all logic elements is provided in Reference 2.

A.5 Computer Softer - M.A. Mingoia and D. Robbins
Faculty Advisor - Prof. S. Yerazunis

The objective of this task was to develop the control software for complete off-board computer control for the autonomous rover. Desired functions

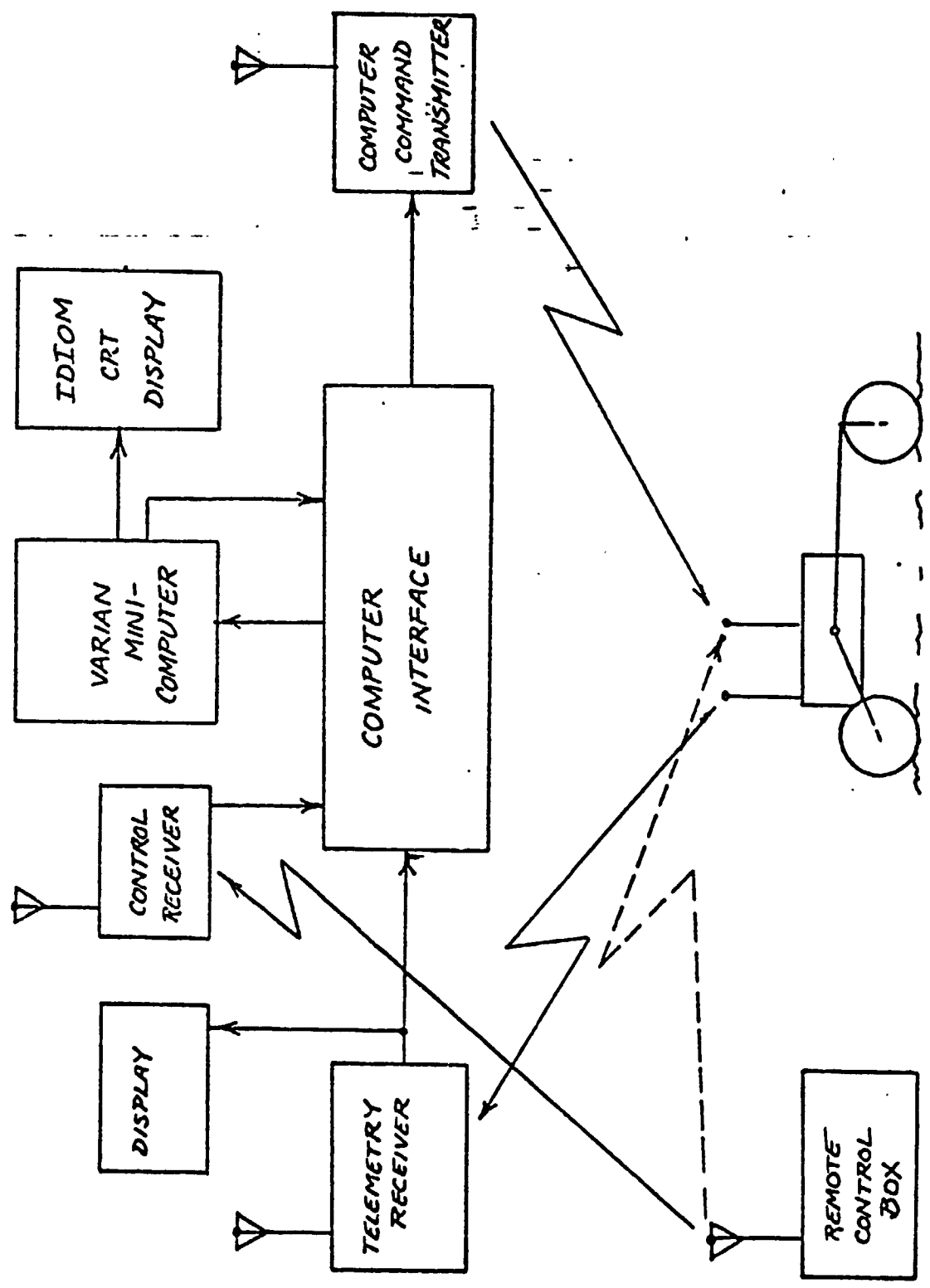

FIGURE 7. CLOSED LOOP COMPUTER CONTROL

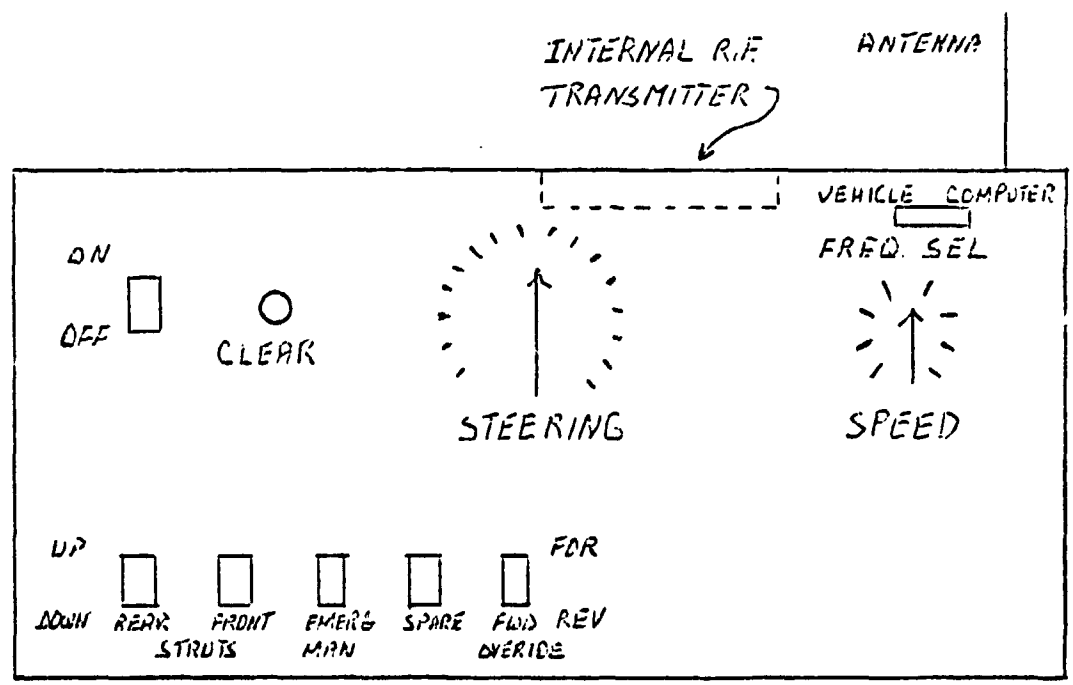
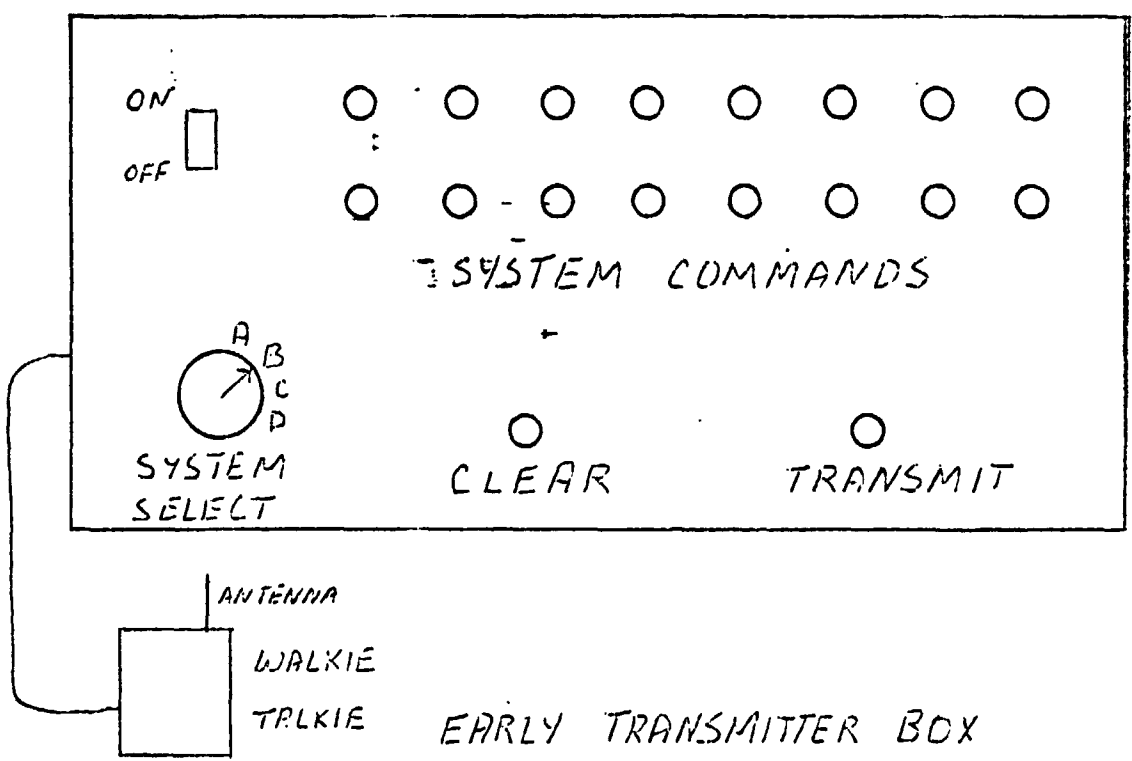

FIGURE 8. Comparison of Prior and Current Remote Control Module

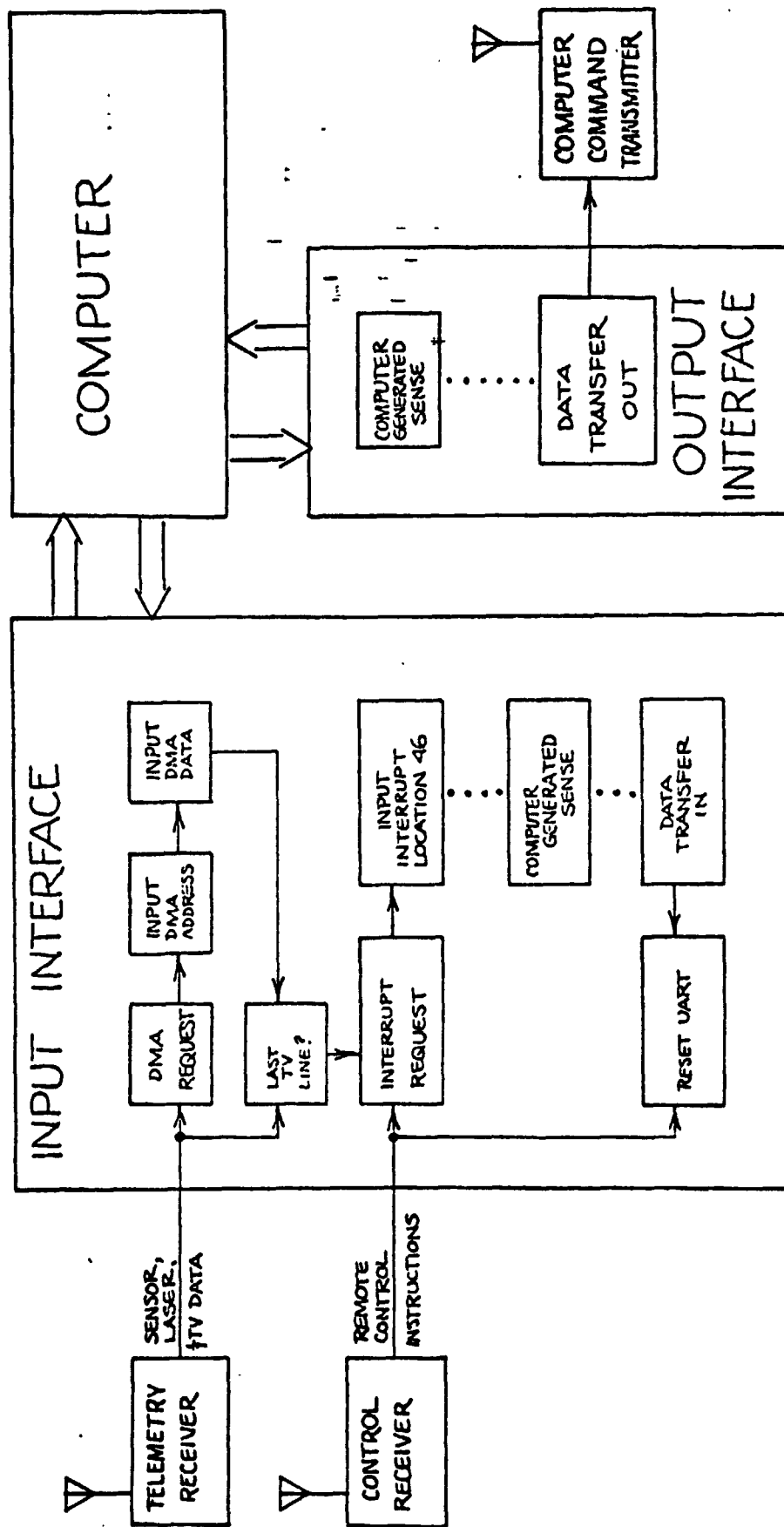

FIGURE 9. Computer Interface Block Diagram

included deployment, path selection, steering, navigation and handling of emergency situations as well as permitting human intervention and monitoring. The programs required to implement these capabilities form the overall software system which is shown in Figure 10. In addition, software required for vehicle development and checkout was developed. The software is programmed in Assembler Language on the Varian/6201 IDIOM Interactive Graphics Computer System.

Developments this year were based on the prior work which developed a graphic simulation/display program which was not coupled with vehicle hardware. During the year, the following software was developed:

1. Support of computer-vehicle interface checkout
2. Coupling of existing graphic display with vehicle hardware
3. TIMER - a real time clock implemented in software for scheduling of vehicle control programs.
4. GYRO - a program to convert directional gyro sensor data into angular information
5. NAVI 1 - a navigation program to define the location of the vehicle with respect to a reference location
6. VEHINT - a program to handle interrupts
7. TRNVEH - a program to translate path selection system decisions into vehicle steering commands
8. OUTPUT - a program for outputting commands to the vehicle
9. PATHSL - the path selection program for the one laser/one detector minimal level system, PSS-1, described under Task C and described in detail in Reference 3.

A general description of the total software and a detailed description of items 6 through 9 above including coding are included in Reference 4. All of these software programs have been checked out with the exception of VEHINT. The checkout includes interaction with all systems including telemetry, hazard detection system and the vehicle. Failure of VEHINT to process interrupts reliably precluded a complete testing of the overall control system for autonomous roving of the vehicle. A first objective in September will be to resolve the interrupt problems so that meaningful testing and evaluation of the minimal path selection system PSS-1 can be undertaken.

A.6 Laboratory and Field Testing - P. Marino, J. Koskol
Faculty Advisor: Profs. G. N. Sandor and S. Yerazunis

The objective of this task was to determine the mobility of the vehicle in both laboratory and field testing with the goal of providing guidance to the hazard detection and path selection systems tasks. The laboratory testing made

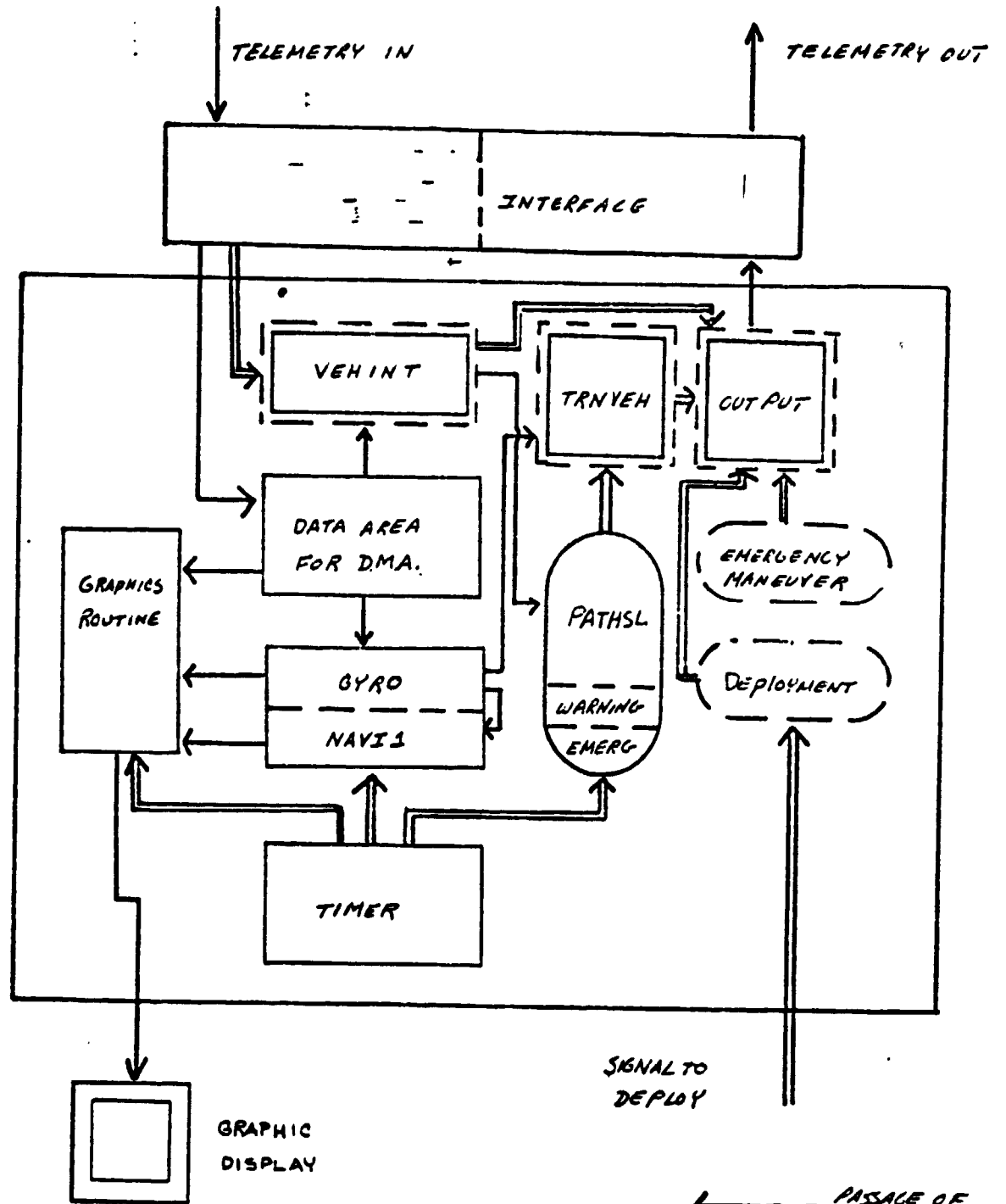

FIG. 10 FLOW OF OVERALL SOFTWARE ACTIVITY

- ←← PASSAGE OF CONTROL
- ← DATA PATH
- - IMPLEMENTED
- (dashed) - DESCRIBED HEREIN
- (dashed) - PARTIALLY DESIGNED
- (dotted) - TO BE DESIGNED

use of an obstacle course which has been described in Reference 5. In brief, a frame constructed of wood and steel provides a basis for creating the desired terrain features using plywood sections. Slopes, open and closed steps and crevasses individually or in combination can be constructed for vehicle mobility measurements. Quantitative mobility parameters were obtained in this fashion. For example, Figure 11 displays the vertical open step climbing capabilities as a function of the slope on which the step is located. This capability ranges from a step of just under 8" to no step at about 32° which is the limiting gradient the vehicle could handle with its grousers on a plywood surface. The vehicle was shown to climb up and over much steeper inverted "V" ridges (slopes of order of 50°) provided that the length of the side of the ridge was four feet or less compared to a vehicle wheelbase of six feet. The vehicle could traverse a 16" wide open crevasse readily.

The height of closed step which can be handled depends on the slope of the surface connecting the low and high sections of the step. Shown in Figure 12 are the results of testing for the horizontal case. This step climbing ability will reduce if the main terrain is upward sloping and increase in the case of a downward sloping situation. Measurements were also made to determine the ability of the vehicle to avoid a hazard as a function of speed. Maximum margin required varied from 23" at zero speed to 100" at high speed (0.35 meters/sec). These data were used as a basis for defining the performance characteristics of the hazard detection and path selection systems under development.

Field testing during the fall on a construction site on the RPI campus suggested that the laboratory tests tended to understate the vehicle's mobility capabilities. This was confirmed in extensive field testing this past spring using a section of the construction site which was contoured to simulate Mars terrain. Craters, steep slopes, ridges and boulder fields were simulated. It appears that real terrain involving dirt particles, sand and rocks provides for improved traction. Unfortunately, the capability has not been quantified, and more definitive experimentation with field terrains is in order. The ten minute 16 mm color film which has been prepared from these tests portrays in a vivid manner the mobility of this vehicle concept.

A.7 Wheel Analysis - R.F. Lipowicz
Faculty Advisor: Prof. S. Yerazunis

The objective of this task was to review the literature in the area of locomotion with the goal of providing guidance in improving the performance of the double-hoop toroidal wheel employed for propulsion. In addition, such experimental measurements as needed for wheel improvement were to be obtained.

Locomotion theory was reviewed in detail with Mars exploration in mind. Included in the review were the open technical literature and a number of NASA supported studies. The mathematical relationships involved were examined for guidance in design modification rather than for computation of an optimal wheel. The reason for this is that it would be of doubtful value to optimize the design for a specific set of terrain parameters when the uncertainties of the Mars terrain are so large. Rather the thinking was to describe a terrain "envelope" and to seek a wheel most suited to deal with surfaces within this range.

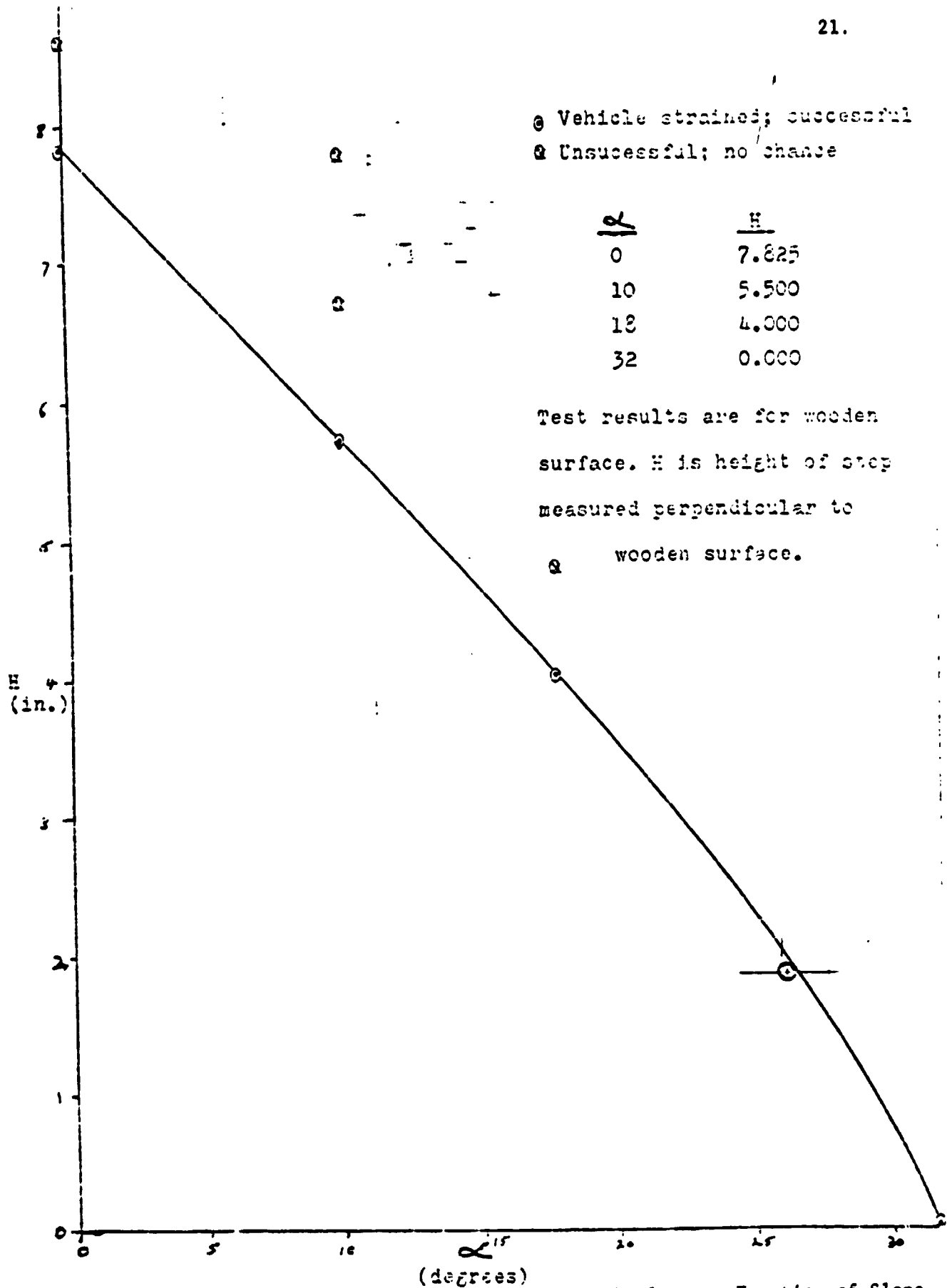
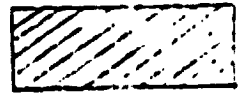

FIGURE 11. Open Step Climbing Ability of the Vehicle as a Function of Slope



22. Obstacle can be overcome

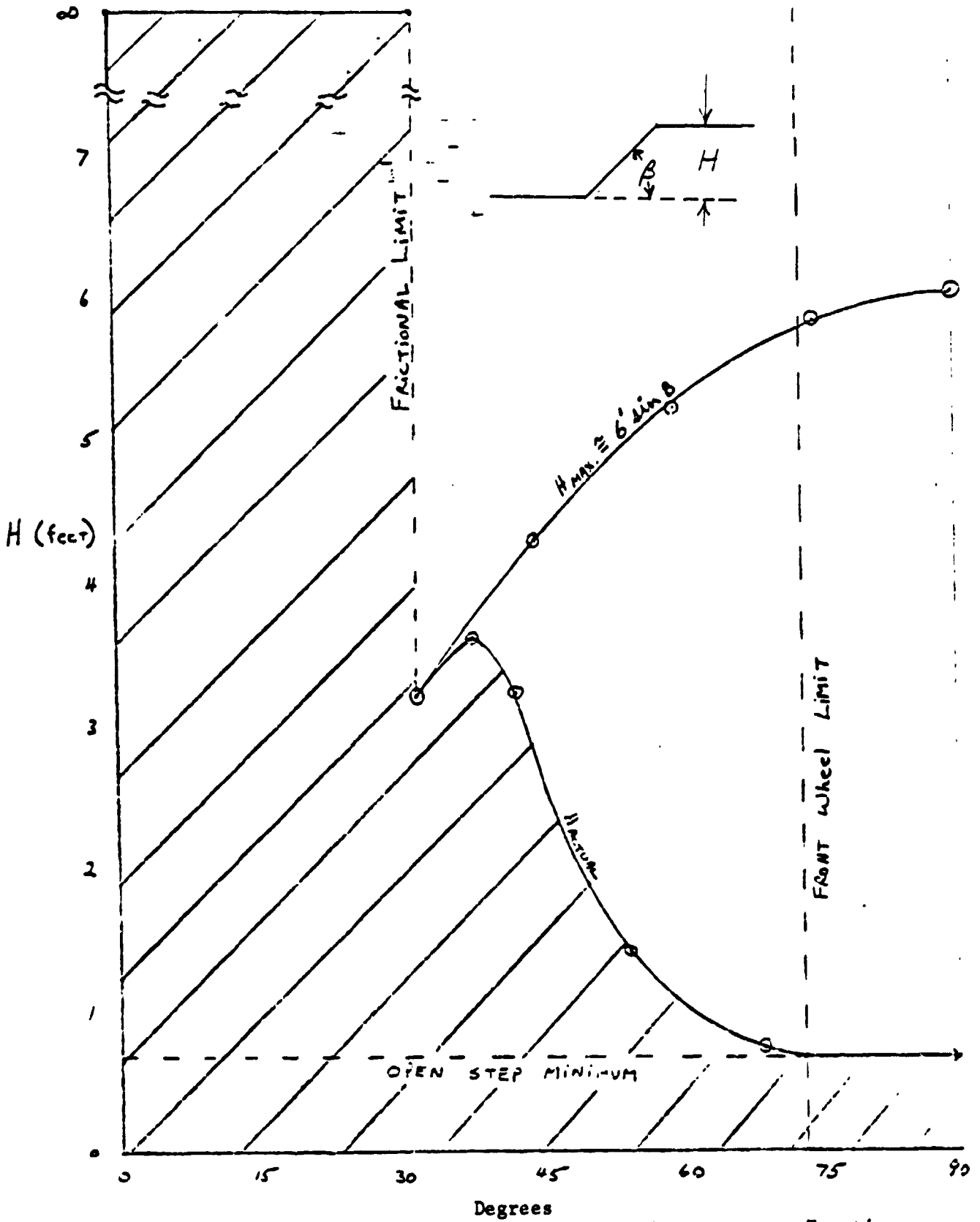

FIGURE 12. Height of Closed Step Which Can Be Overcome as a Function of the Slope in the Step

With this in mind and defining a terrain "envelope" consistent with projections of the nature of the Martian soil, the following guidelines were deduced:

1. The Martian soil should be assumed to be cohesive rather than frictional.
2. Flotation, the ability of the vehicle to remain on the surface of very weak soils, is improved by increasing not only the footprint area but also by increasing the width of footprint. Hence, width enters as the square in its effect.
3. Motion resistance is the sum of compaction and "bulldozing" effects. The compaction resistance decreases with increased footprint length and width with length having a stronger influence. Bulldozing resistance increases with increased footprint width; however, this resistance component tends to secondary impact in frictional soils. Thus net motion resistance is decreased with increases in footprint length and width and, therefore, in area.

On an overall basis, it is concluded that an increased footprint area as brought about by footprint length and width is to be sought to increase flotation and to decrease motion resistance.

There is a second consideration which has been disclosed by laboratory and field testing the RPI rover in regard to its ability to climb bluff objects such as boulders. The softer is the wheel footprint, the more traction is gained since the grouser conforms more to the tractive surface, (essentially envelopes curved surfaces). This requirement is consistent with increased footprints for maximum flotation and minimum motion resistance. However, there is a tradeoff between the benefits to be gained by "softening" the wheel to increase footprint and the mechanical integrity of the wheel, particularly under dynamic loading. Earlier wheels which had been made quite soft were found to fail under the dynamic loads encountered within too short a time. It is believed that alternatives such as pre-stressed hoops, appropriate hoop spokes and grouser support may permit the use of a relative "soft" wheel with large footprint which is capable of dealing with the maximum dynamic loads to be expected. As noted under Task A.1 a wheel tester has been constructed for investigation of alternative designs. It is expected that definitive results will be available by December 1976.

The second thrust of this task was aimed at the measurement of individual hoop/force deflection characteristics as a function of the restraining hoop spoke and of complete wheels with and without a grouser. A heuristic design procedure relating full wheel performance in terms of specified footprint to individual hoop design parameters (i.e. band width and thickness and stiffening spoke dimensions) was developed.

A static loading device was conceived, Figure 13, in which individual hoop deflections could be determined as a function of the hoop orientation relative to the direction of the force as well as of hoop and spoke parameters. Figure 14 shows the results for hoops of three different widths and thicknesses.

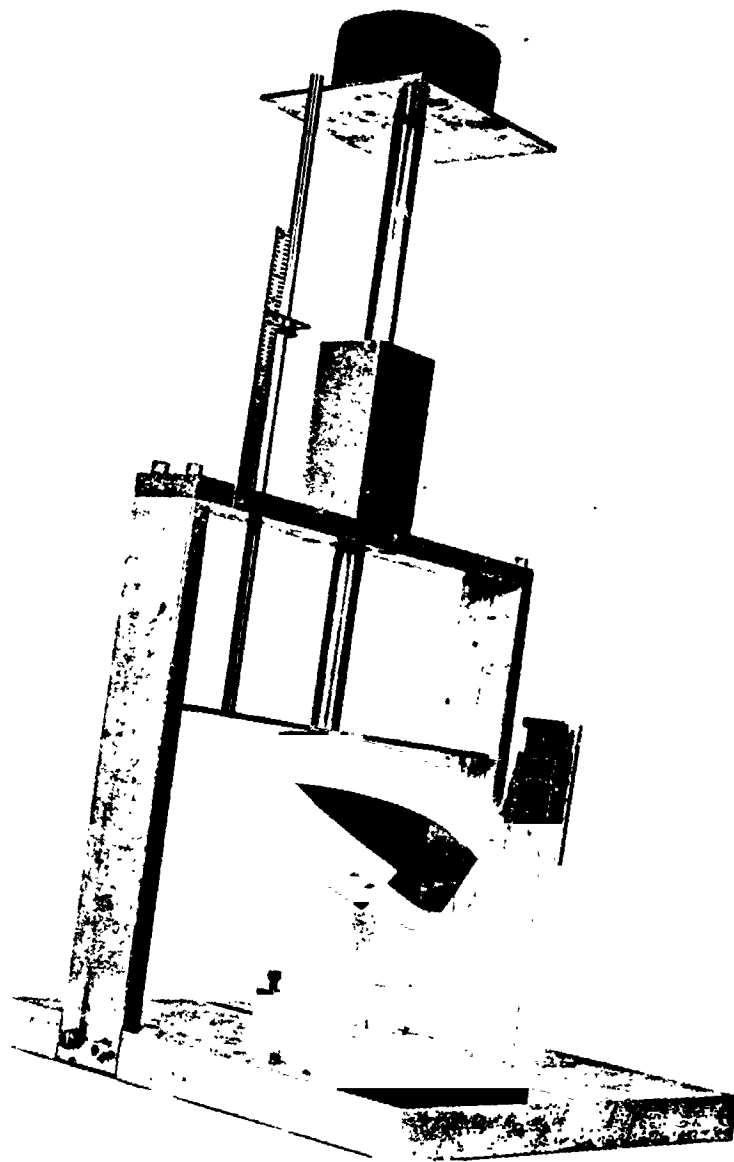

HOOP IN TEST POSITION - 3
FIGURE 13

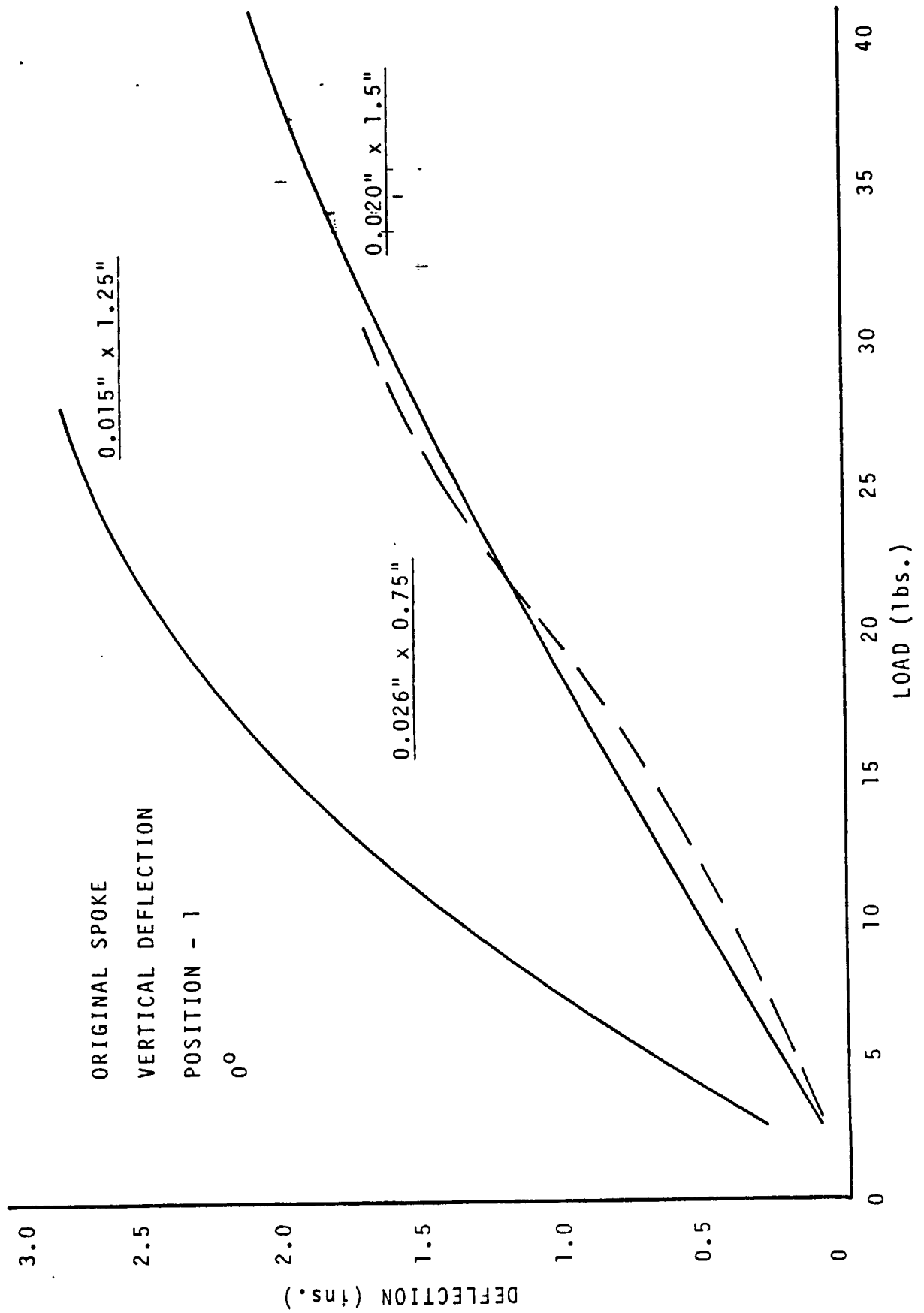

FIGURE 14.

for one hoop/force orientation and one stiffening spoke configuration. Such measurements were made at four different hoop/force orientations, four spokes, and three hoop parameters to gain some insight in the behavior of the individual hoops.

Subsequently, a complete wheel was tested using hoops of one single width and thickness, one stiffening spoke configuration under three different conditions: (a) without grouser, (b) with a grouser but without grouser/hoop bonding and (c) without a grouser but with a circumferential band of spring steel to which each hoop was attached rigidly. Figure 15 compares the results obtained for these three cases. It is interesting to note the load/deflection characteristics of the unconstrained hoop case (no grouser or outer band) and of the wheel with the outer steel band of essentially the same. However, the wheel equipped with the grouser is significantly stiffer. Apparently, the grouser side walls tend to stiffen these sections of the hoops, thus increasing the stiffness of the wheel as a whole. It should also be noted that the load/deflection characteristic observed for small deflection of the complete wheel corresponds closely to the load/deflection pattern for a single hoop.

Combination of the total wheel load/deflection results with those of individual hoops through a chain rule procedure provides an empirical basis for predicting wheel footprint area as a function of the moment of inertia of the individual hoops. Complete details of this program are reported in Reference 6.

A.8 Payload Protection Systems - R. A. Marin Faculty Advisor: Prof. S. Yerazunis

The objective of this task was to investigate alternative methods for protecting the payload from terrain hazards which would not be detected by current concepts in hazard detection systems for path selection. Consideration was given both to electro-mechanical and electro-optic alternatives. These included: a mechanical tactile feeler system, a laser/detector triangulation concept similar to the current hazard detection system but on a smaller scale and a reflectance concept. On the basis of preliminary analysis it was decided to pursue in depth proximity sensing based on reflectance. Accordingly, the main thrust of this task was re-directed to determine the characteristics of such a system.

A transmitter involving a light emitting diode pulsed for 72 microseconds in a total period of 72 milliseconds was designed and constructed. Because of the short pulse interval and the relatively narrow divergence angle ($\sim 24^\circ$) illumination of acceptable intensity was obtained. A phototransistor receiver of high gain and sensitivity was also constructed.

Listed in Table I are the test surfaces which were studied to determine the feasibility of the concept. Shown in Figures 16 and 17 are the received signals as a function of material and distance from the sensor to the reflecting surface for the case where the transmitted beam is normal to the surface. It is to be noted that the strength of the signal varies markedly with distance according to the expression

$$\text{Signal} = K (\text{Distance})^{1.7}$$

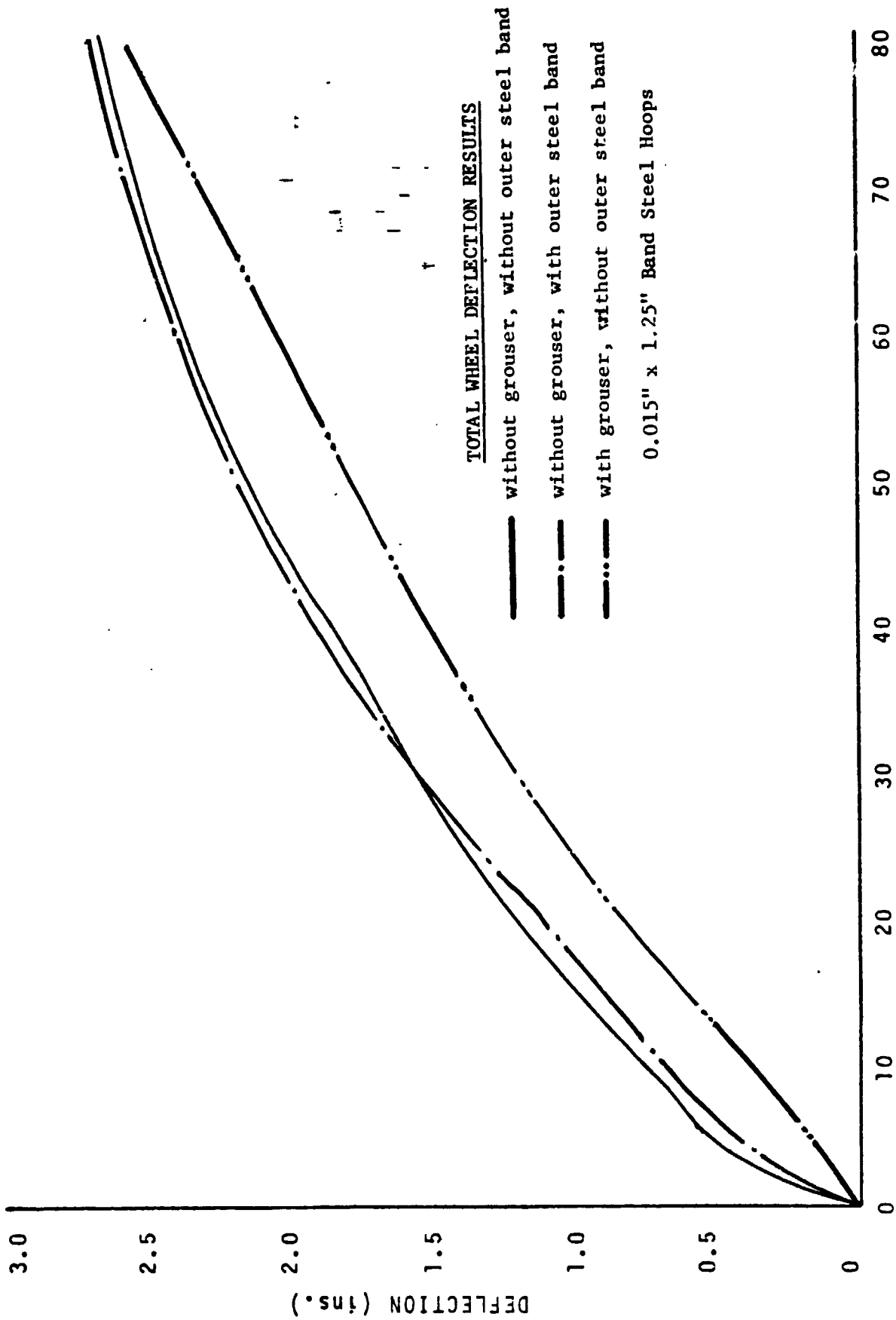

FIGURE 15. Total Wheel Deflections as a Function of Load

TABLE I

Description of Test Surfaces

Glass mirror
Shiny copper
Oxidized aluminum
White photostat paper
Extra fine white sandpaper
Coarse white sandpaper
Washing cement (gray talc)
Granite stone
Red talc
Brown soil (Mars soil)
Brown soil spheres
Slate rock
Coarse black emery paper
Aluminum-painted ultra flat black

*Complete specification of test surfaces in Reference 7.

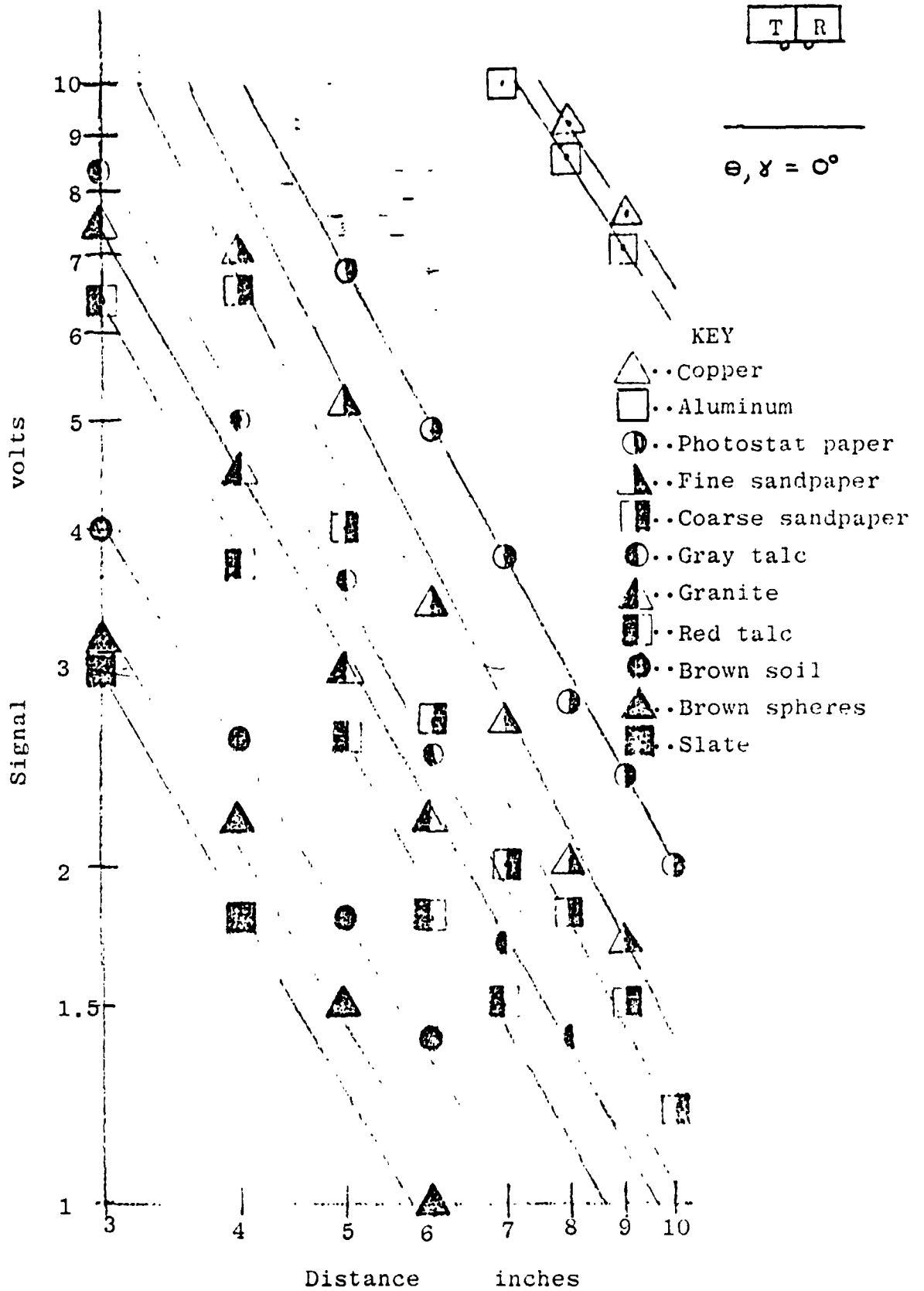

Figure 16

GRAPH of SIGNAL VS. DISTANCE (0.1 to 1.0 volt)

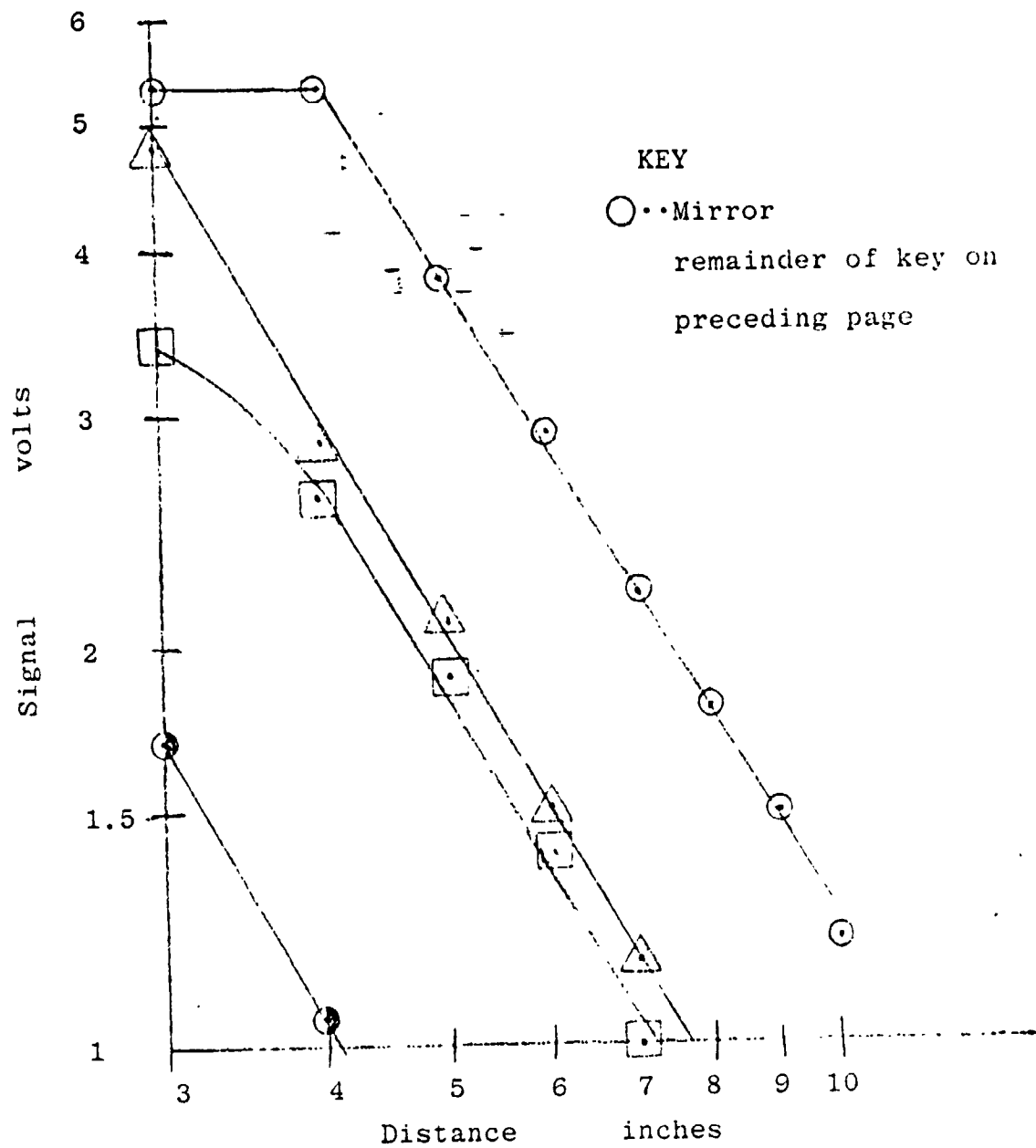

Figure 17
 GRAPH of
 SIGNAL VS. DISTANCE
 (1.0 volt and greater)

In addition the strength of the signal is a strong function of the surface involved. For example, the ratio of signal received from fine sandpaper to that of slate is approximately four.

The effect of inclination of the reflecting surface relative to the axis of the incident light was also investigated. Figure 18 presents the results obtained for fine sandpaper, slate and a mirror. The relative reflectance defined as the signal strength at the specified inclination divided by the strength at 0° inclination falls off relative slowly for diffuse reflectors such as slate and sandpaper as compared with the abrupt reduction with a mirror.

The concept has as a major advantage in its behalf extreme simplicity and could conceivably provide the detection required to protect the payload from bluff terrain features in its path or from too low a clearance. Its feasibility is favored by the strong relationship between signal and distance between the transmitter/receiver and the reflecting surface. However, the great variation of reflectivities which were observed represents a serious handicap. If it can be assumed that the reflectance of typical Martian surface may vary from that observed for sandpaper to that of slate, the factor of four in reflectance will require that the system must tolerate a significant margin of uncertainty. For example, if the system is set to detect slate at a distance of three inches with incident radiation normal to the surface, a sandpaper surface at just under seven inches will trigger an emergency. Confounding the problem is the effect of inclination between the light beam and the surface, Figure 18. A slate surface inclined at 50° or 60° would approach the payload surface more closely than three inches before detection.

Despite these drawbacks, a payload protection system based on reflectance proximity sensing may prove to be feasible particularly if the reflectance coefficient range for martian surfaces is narrower than the example cited above. The simplicity and reliability of the concept and the strong relationship between signal and distance argue in behalf of the concept. Complete details of this study are provided in Reference 7.

TASK B. Terrain Sensing and Data Handling

The objective of this task is to design and construct the terrain sensing devices and the associated data handling systems required to implement autonomous roving.

B.1 Laser Transmitter/Receiver - D. Holly, S.G. Cairns Faculty Advisor - Prof. D. Gisser

The basis behind the terrain sensing system which was selected for implementation is shown in Figure 19. The principle of triangulation is employed to determine if terrain is situated within the zone of intersection of a laser beam (transmitter) and a photodetector (receiver). The region of uncertainty within which terrain could be assumed to be located if the receiver detects a reflection can be made larger or smaller depending on the relative locations and orientations of the transmitter and receiver and on the cone of vision of the detector. In principle, multiple laser (or equivalent scanning) and multiple detectors can be employed to gain as detailed as desired knowledge of the terrain in front of the vehicle.

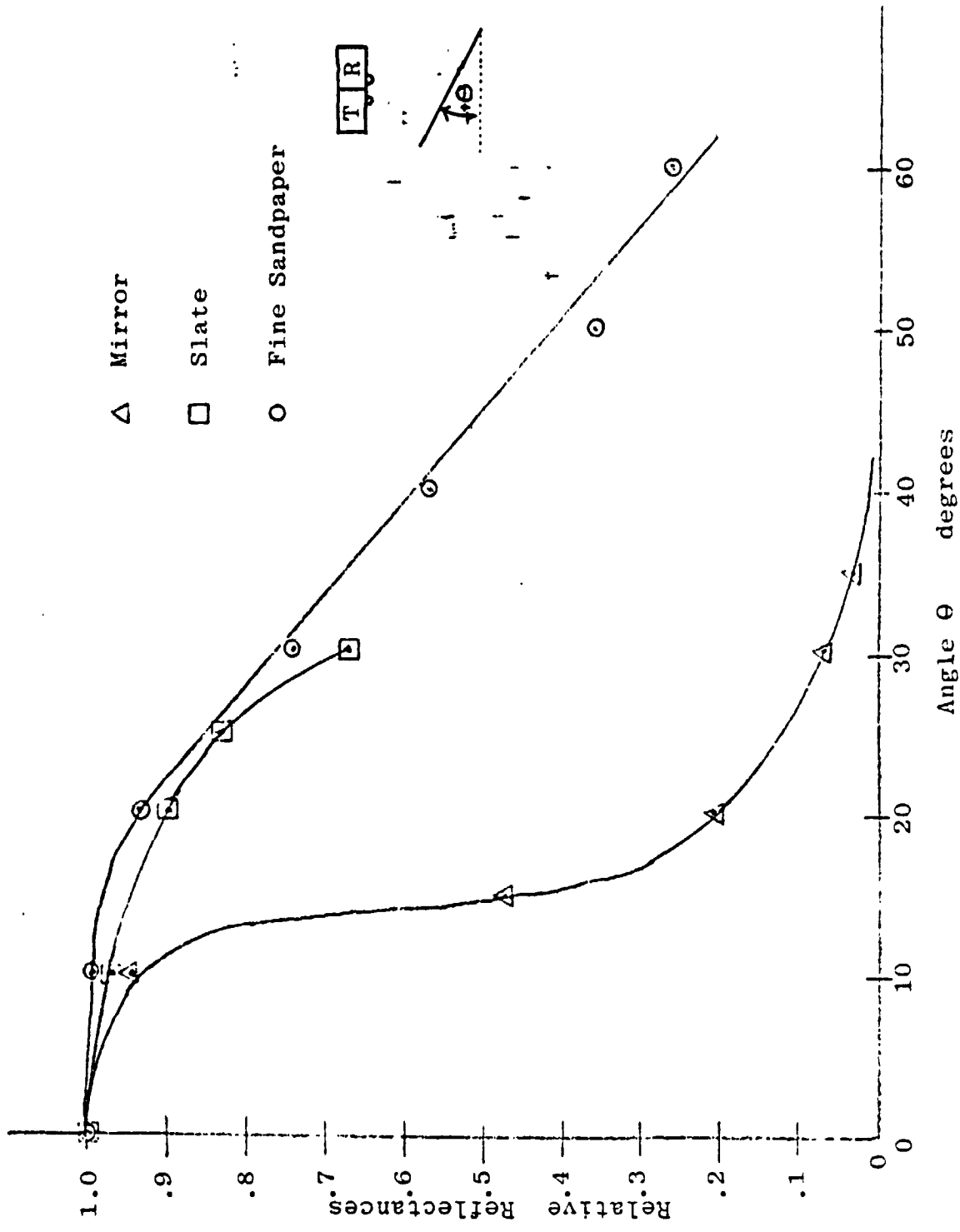

Figure 18

INCLINED SURFACE GRAPH II

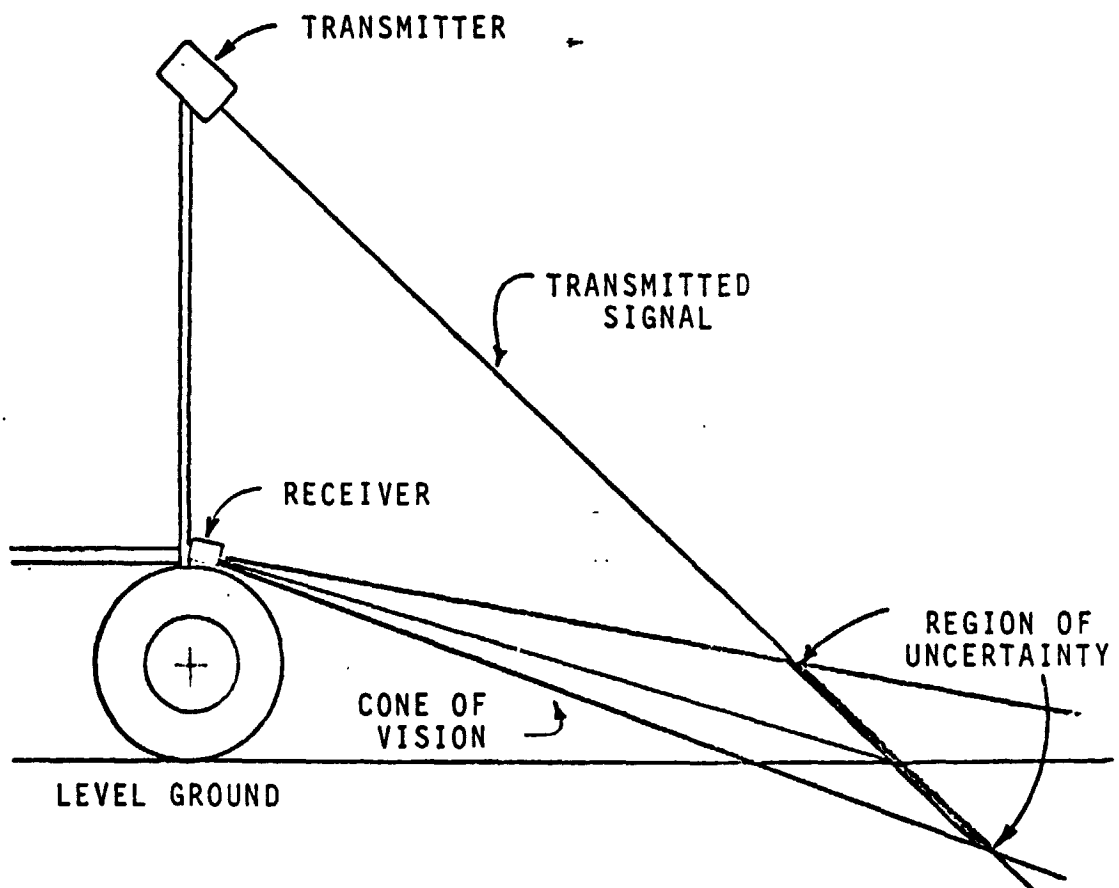

FIGURE 19. TERRAIN SENSING CONFIGURATION

For the objective of demonstration and evaluation of a minimal autonomous roving system, this task was directed to the development of a one laser/one detector system to implement Path Selection System 1 as defined under Task C. The manner in which hazards are detected in PSS-1 is illustrated in Figure 20. So long as the detector receives a signal, it is assumed that the terrain is within the specified zone and involves no hazard. However, loss of signal will indicate the existence of either a positive or negative hazard. This simple one laser/one detector system cannot distinguish between positive or negative hazards but only that the terrain is outside the zone considered safe. There are special circumstances which will give rise to a loss of signal which will be interpreted as a hazard where in fact none exists, Figure 21.

The transmitter is designed to fit inside the mast to reduce the radius of gyration, Figure 22. When the transmitter is mounted in the mast, the laser points upward and the laser beam is deflected downward at the desired elevation angle by a fixed mirror. A block diagram of the transmitter is provided in Figure 23. The laser which can be fired at a rate of about 700 times per second is controlled by the Data Handler/Controller system described under Task B.2.

The receiver design, Figure 24, overcomes the problem of spurious noise being interpreted as a true signal by incorporating an amplitude discriminator and a time discriminator. The amplitude discriminator senses the general level of noise and automatically compensates to reduce the probability of interpreting noise as a true signal. The time discriminator is triggered by the Data Handler/Controller to define a "window" corresponding to the laser firings. Thus the receiver is looking for a light pulse only during those short periods of time when a pulse can be expected. The effectiveness of these systems is demonstrated by tests in which the presence of negative hazards at the 2-3 meter range was detected in bright sunlight. Complete details of the laser transmitter and receiver are provided in References 8 and 9.

B.2 Data Handler/Controller - D.H. Holly and T.R. Geis
Faculty Advisor: Prof. D. Gisser

Central to the laser transmitter/detector systems described above is the data handler/controller system. This system is responsible for controlling the firing of the laser, controlling the time discriminator of the receiver and processing the data prior to transmission of the data by telemetry to the computer. The data handler/controller which was constructed can handle up to three laser transmitters and five receivers. The lasers can be paired up with particular receivers or they can be lumped together. The system can tell which laser is associated with which receiver in any configuration which may be employed.

The reliability of the data output from the data handler/controller is enhanced by two features. First, the time period during which the receiver looks for a pulse is coordinated with the firing of the laser. Second, multiple testing for each point is provided up to a maximum of six shots per laser. The returns for each of these shots are summed up and compared with some pre-set (controllable by the user) criterion to determine if the set of data constitute a valid return. A block diagram of the data handler/controller is shown in Figure 25. Since the firing rate of the laser which is being used is limited

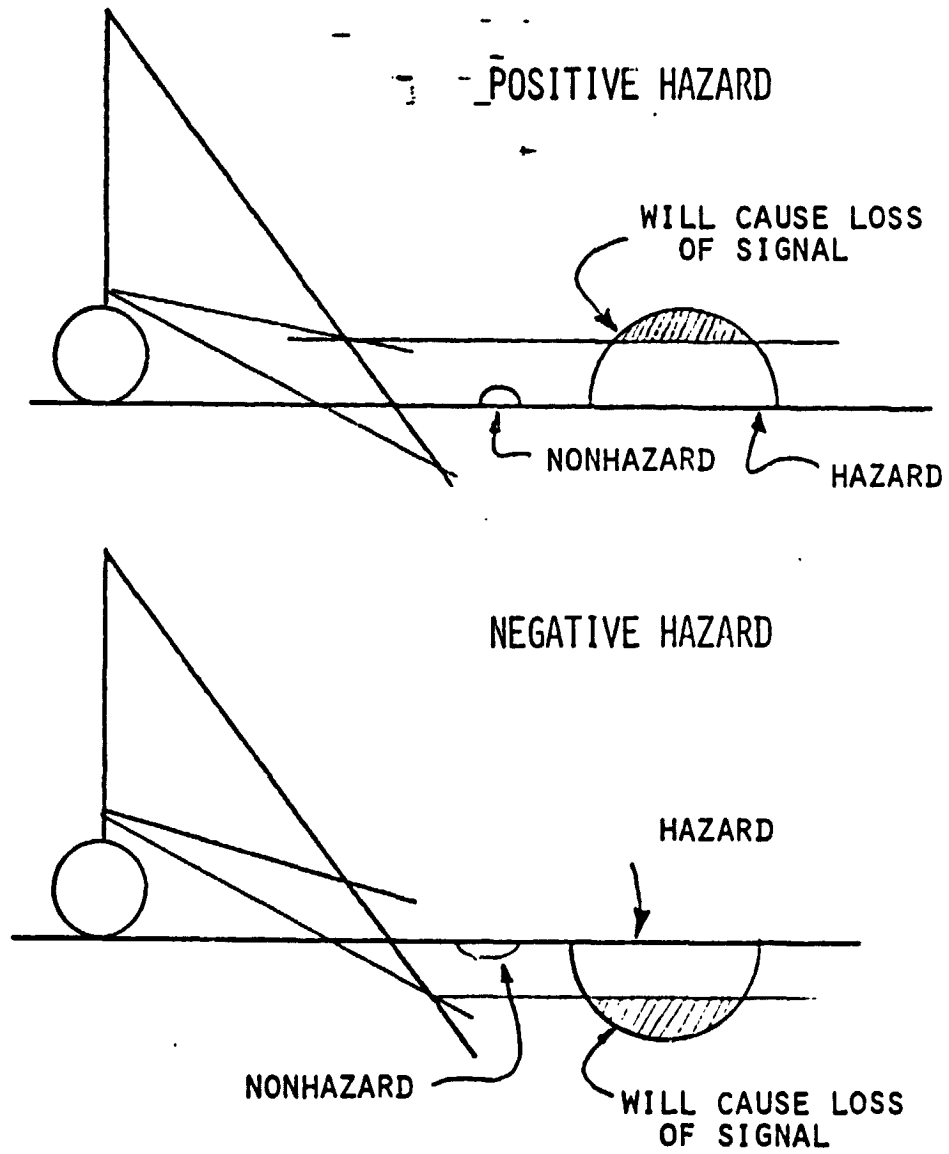
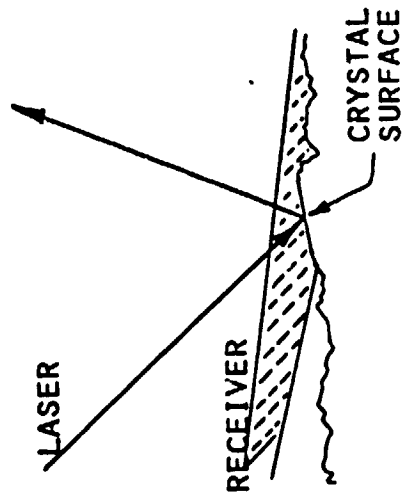
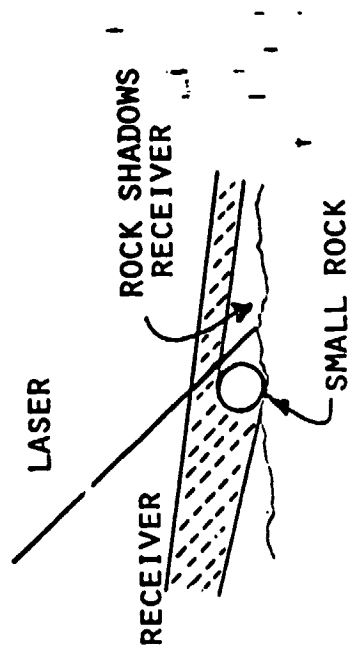

FIGURE 20. EXAMPLES OF HAZARDS



(A). NO RETURN SIGNAL
DO TO REFLECTIVE
SURFACES.



(B). LOSS OF SIGNAL
DO TO SHADOW OF SMALL
ROCK.

FIGURE 21. Examples of Nonhazards that cause loss of signal

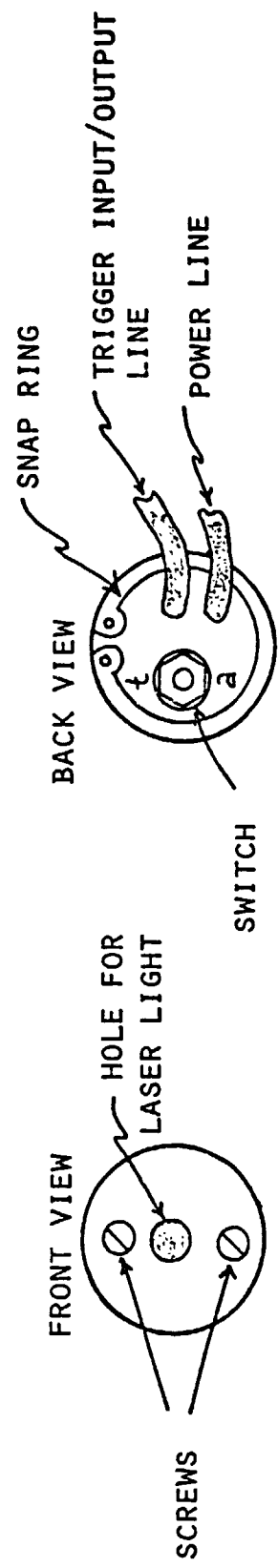
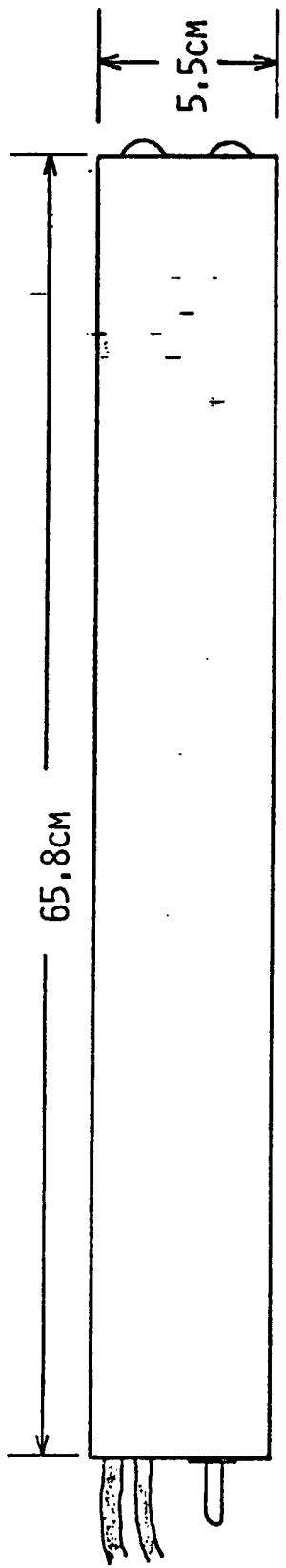
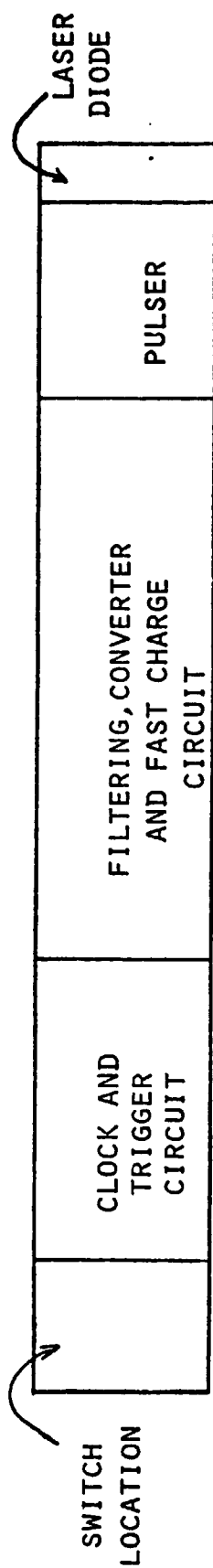

FIGURE 22. Physical layout of transmitter

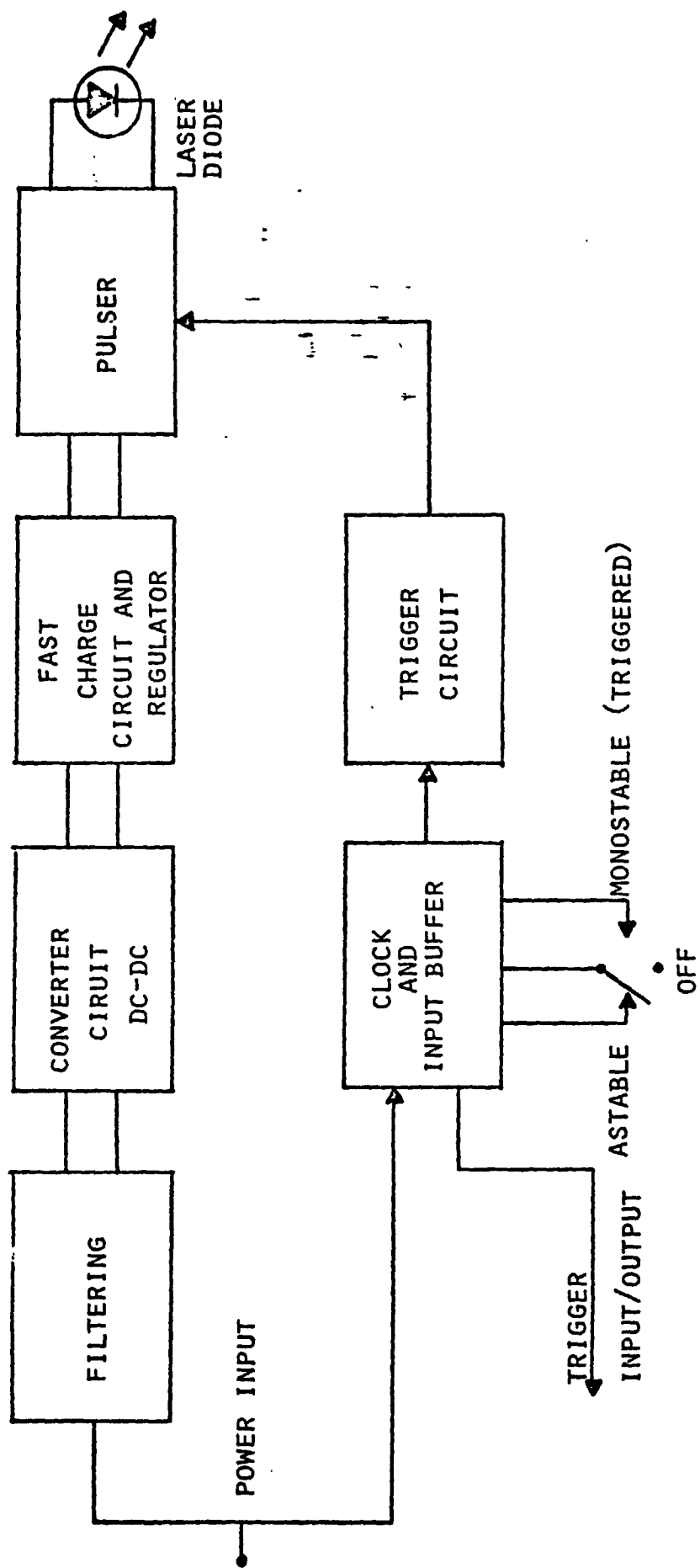
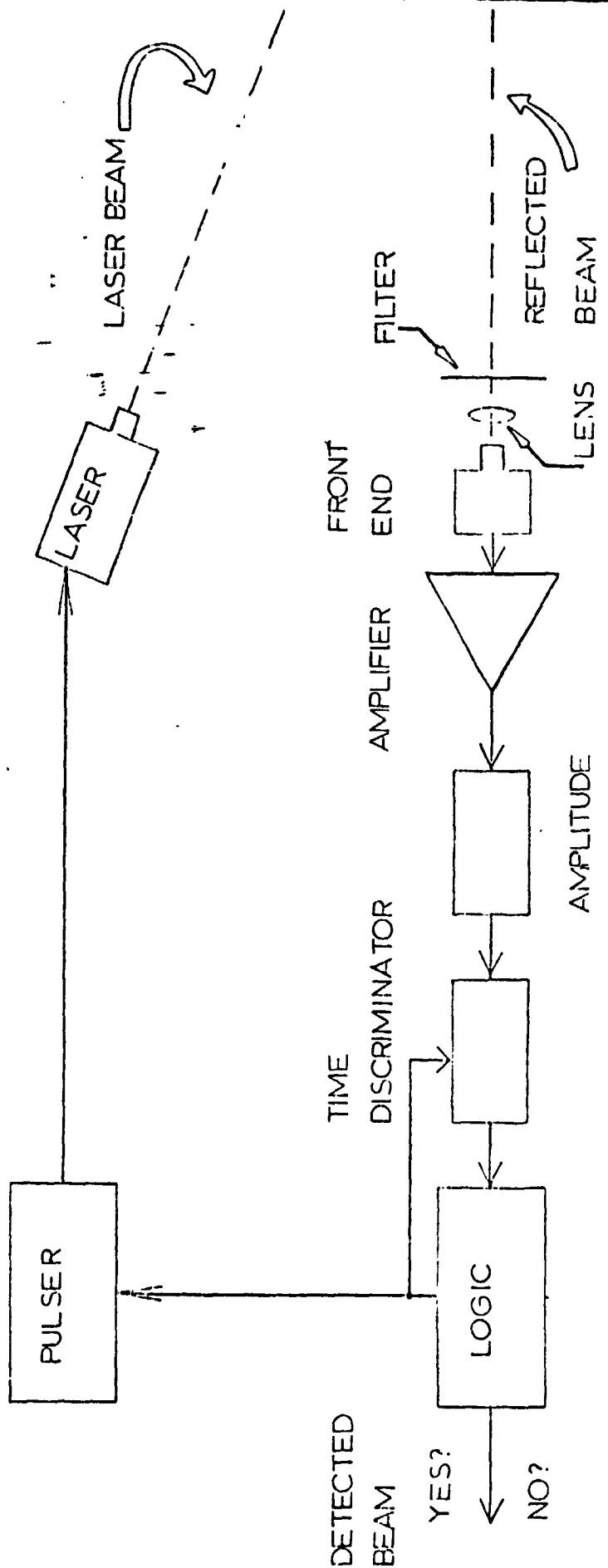

FIGURE 23. Basic Transmitter Sections



REVISIONS		SYSTEM BLOCK DIAGRAM	
NO.	DATE	BY	DATE
1			
2			
3			
4			
5			

OBSTACLE DETECTOR
 DRAWN BY: [Signature]
 CHECKED BY: [Signature]
 SCALE: [Blank]
 DATE: [Blank]
 REVISIONS: [Blank]
 NO. OF SHEETS: 2
 SHEET NO.: 2

FIGURE 24. Receiver Block Diagram

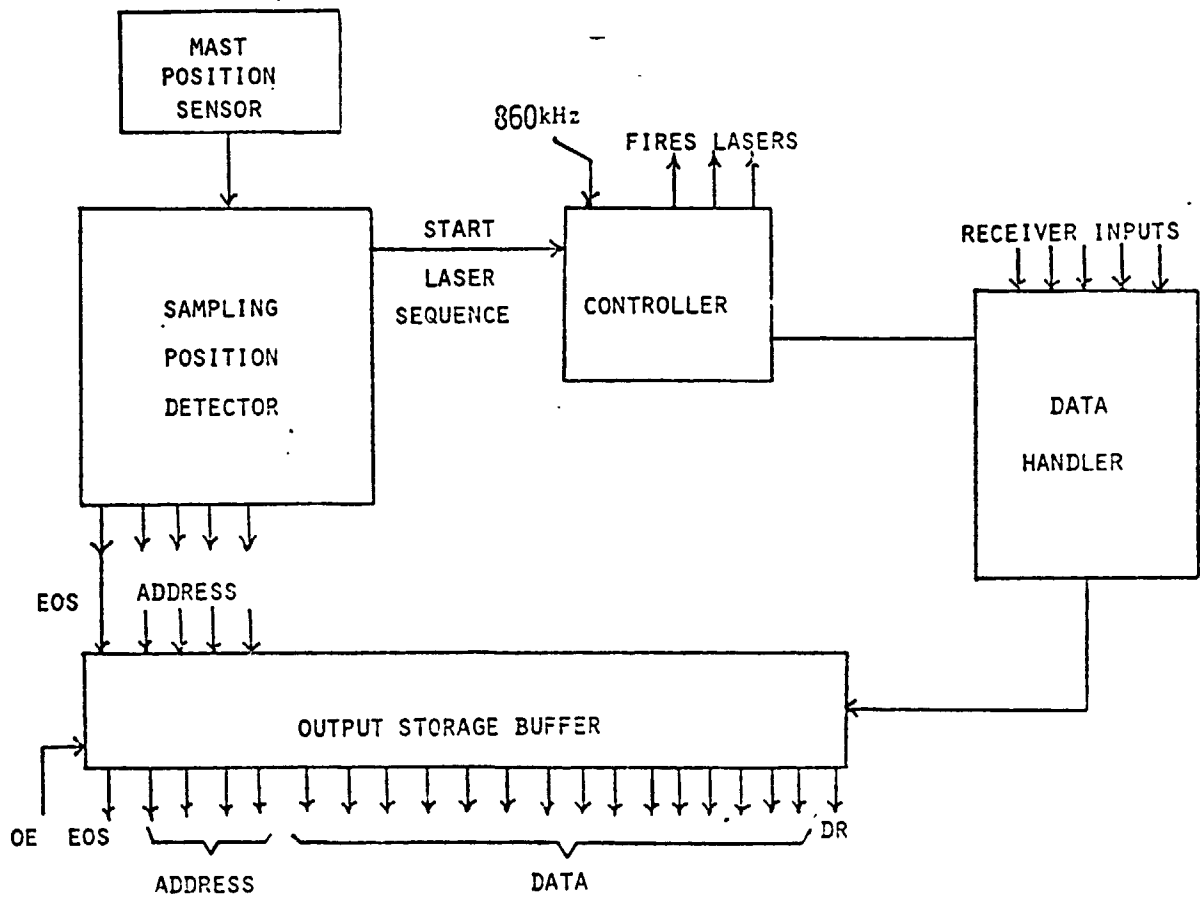

FIGURE 25. DATA HANDLER/CONTROLLER

to 1000 pulses/sec, the data handler arranges to fire each laser at 1 msec intervals. Thus with three lasers, a laser pulse would originate every 0.33 msec and all receivers would be timed accordingly. If the maximum repetition of six pulses per measurement is required with a single laser, the entire process is completed in 6 msec (7 msec if three lasers and six pulses are specified), during which time the motion of the mast (at two cycles/second) would impose about a 10 cm arc at about 1 meter. Since Path Selection System 1 is based on a 15 path direction concept, the data handler/controller system makes use of the mast position sensor in controlling the laser pulses. Details of the data handler/controller system are provided in Reference 8.

TASK C. Path Selection System Development and Evaluation - J. Krajewski
Faculty Advisor: Prof. D. K. Frederick

A path selection system has been developed using a laser-sensor triangulation method described earlier under Task B.1. In simulation this system has been able to detect and avoid both positive and negative obstacles in a noisy environment. The method of using triangulation has developed into a more sophisticated path selection system utilizing up to three laser-sensor pairs and incorporating memory. Data obtained by the triangulation sensors and vehicle attitude sensors is processed by a terrain modeler. The processed information is then sent to the path selection algorithm, where a decision concerning the vehicle's new path is made.

This system, simulated as described, has been able to handle terrains of varying complexity, ranging from simple boulder-crater fields on horizontal planes to rolling, boulder-crater covered hills. To traverse the more difficult terrains, the three laser-three sensor configuration was required. The amount of terrain information gathered by the simpler laser-sensor configurations was insufficient to avoid interpreting relatively safe paths as impassable.

An alternate path selection scheme was also developed to determine if a memory-less system would be feasible. Due to inherent drawbacks involved, such as repeatedly encountering the same obstacle, this system proved unable to negotiate even the most simple terrain.

Any path selection system can be broken down into three distinct subsystems: The sensor, the terrain modeler, and the path selection algorithm. Each has a separate and vitally important function. The sensor employs some means of gathering information about the terrain surrounding the vehicle. The terrain modeler processes the raw terrain information coming from the sensors, separating obstacles from non-obstacles. The path selection algorithm processes this "view" and, possibly together with past "views", makes a decision as to which direction to proceed during the next time interval. The final output of the entire path selection system, therefore, is a periodically updated heading angle.

Each of these subsystems, as they apply to the simulated system, are discussed more specifically below.

The sensor system utilizes a laser-sensor triangulation scheme to gather terrain information, Figure 25. The laser is mounted on a vehicle-fixed mast and aimed downward such that the beam intersects the surface. A sensor consisting of a photodetector with associated optics is placed at a lower position on the mast and "looks" somewhere along the laser beam at the same azimuthal

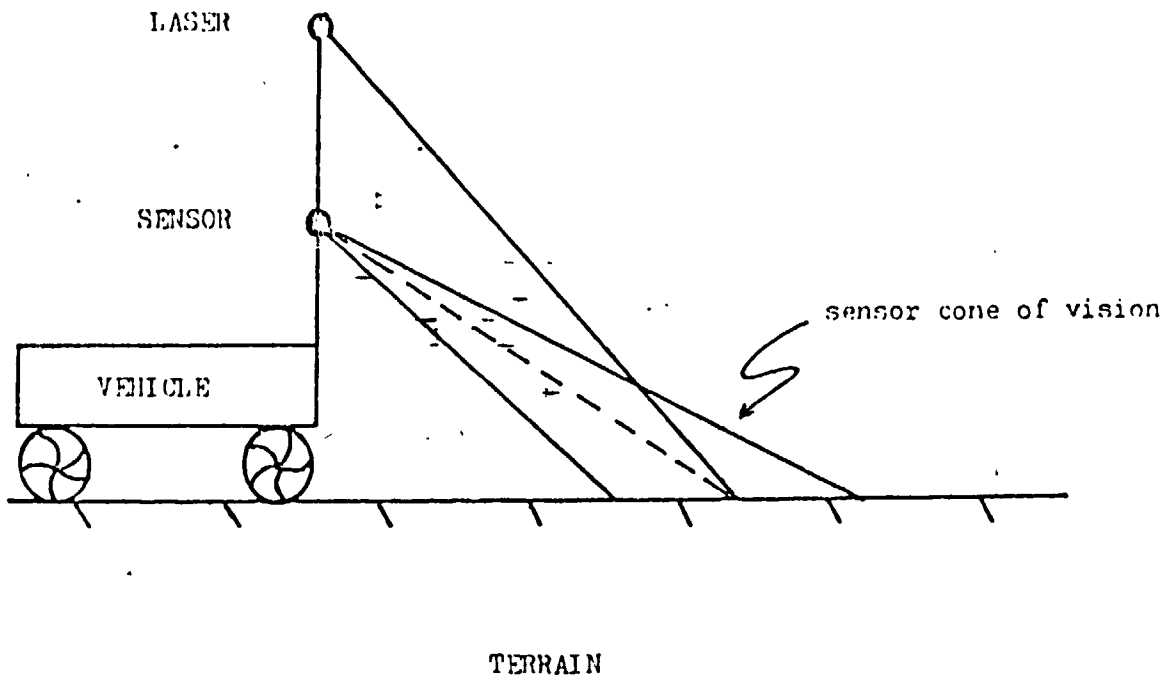

FIGURE 25. Laser - Sensor Triangulation Scheme

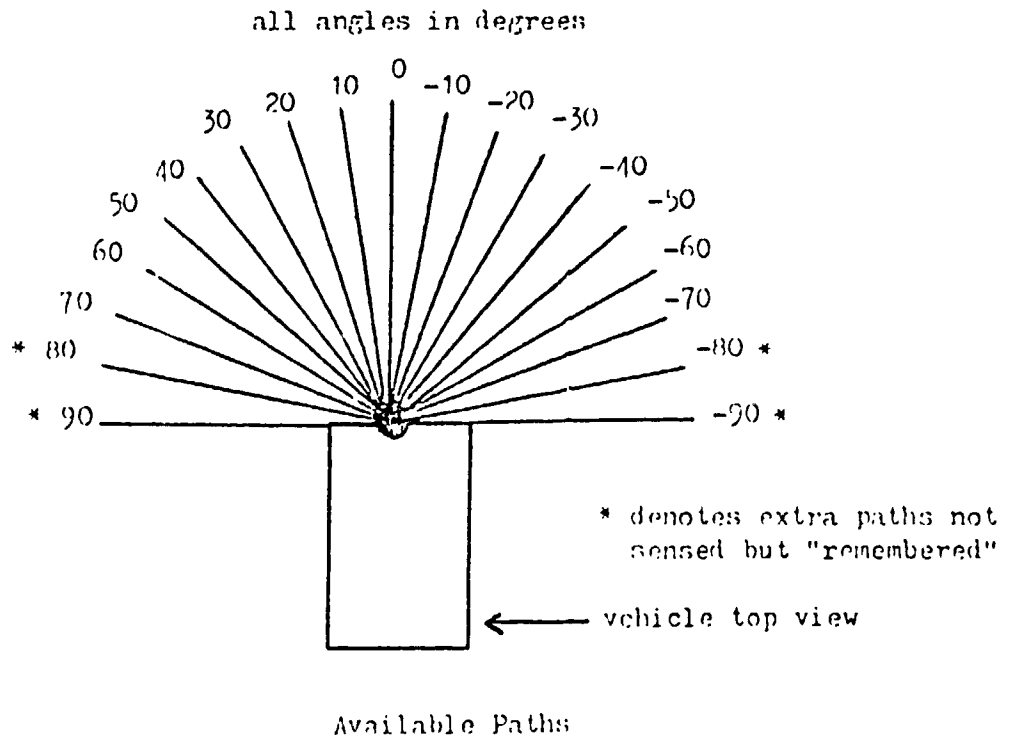

FIGURE 26. Sensed and Available Paths

angle. The sensor, having a sharply defined cone of vision, therefore samples the line segment formed by the beam-cone intersection. If terrain is present within this it will scatter the laser pulse and thus result in the sensor detecting the beam, providing the path from the laser down to the terrain and back to the sensor is clear. The basic operation of each laser-sensor pair, then, is to detect the presence or absence of terrain within a designated line segment, the size and orientation of which is dependent upon the laser and sensor heights, elevation angles, and the sensor cone size.

The terrain modeler is a specialized data processor which provides the logic necessary to combine the signals from the sensors into an array of 15 "sensed paths", each designated go or no-go. These paths are separated by 10 degrees in azimuth and form a cone 70 degrees to each side of the vehicle centerline, Figure 26. The terrain modeler incorporates vehicle attitude information by deciding if the inpath and crosspath slopes are too great for continued travel in a certain specified direction. These attitude warnings are necessary to prevent the vehicle from encountering hazardous situations which the sensors may overlook.

The path selection algorithm accepts as inputs the 15 sensed paths, designated go or no-go, from the terrain modeler. It then incorporates this information into a "world model" composed of previous obstacle encounters and turns made. Using the present vehicle position (also an input) and the target position stored in memory it first computes the optimal heading angle assuming no obstacles were present. Next, the algorithm searches its world model for the path closest to this heading from among 19 possible paths, which is not designated no-go. If a path meeting the above requirement exists, its heading angle is outputted. If a go path cannot be found, an emergency mode can be invoked, allowing the vehicle to back up.

Paths may be designated no-go as a result of the memory structure in the algorithm. This was deemed necessary for this system since the vehicle is two meters long and the sensed region (as simulated) is a circular zone with a maximum radius of 1.5 meters in front of the vehicle. In order to safely avoid obstacles, a method of remembering their presence for a short time after they pass from view is necessary. Also, since the vehicle cannot turn instantaneously a turn memory is needed to allow the vehicle to straighten out before another sharp turn in that direction can be made.

One final feature of the present path selection algorithm is the "bump" filter. This software constantly averages the previous two pitch readings of the vehicle's attitude gyro and compares the latest reading to this value. If the difference is greater than some preset threshold the scan is assumed invalid due to excessive attitude noise (rubble) and is therefore ignored. This feature becomes useful in the more advanced systems.

The above descriptions of the terrain modeler and the path selection algorithm are applicable only for the system with memory. In the memory-less system, the sensor subsystem remains essentially unchanged from the one laser-one sensor configuration already discussed. The terrain modeler and the path selection algorithm are necessarily different, however, in that memory can no longer be used. The terrain modeler no longer utilizes attitude information, and the go/no-go map it provides is constructed solely from sensor indicated hazards. The path selection algorithm accepts the map from the modeling block

and chooses the available path which lies closest to the optimum heading, and which is indicated as being unblocked. One final difference to be noted is that the available paths, from which the path selection algorithm chooses a new path, are in no way dependent upon the scanning angles of the sensor. The heading angles of the paths and the angles at which the sensor scans are independently specified at the beginning of each simulation. This allows a somewhat greater degree of flexibility in the simulation procedure. More explicit details of this system can be found in Reference 3.

The initial laser-sensor configuration chosen for the path selection system with memory was the most elementary, consisting of only one laser and one sensor. It became apparent, however, that successful traversal of non-flat terrains required more data than was available from this simple system. An evolutionary sequence of three laser-sensor configurations, all sampling the same azimuth angles, finally resulted, referred to as systems A, B, and C, in order of increasing complexity. For the memory-less system (system D), subsystems were not altered during simulation.

System A (1 laser - 1 sensor)

This sequence of tests employs boulder-crater fields with and without attitude noise, and also sine wave terrain without attitude noise. The first two runs (Figure 27) show that the single laser-sensor configuration can handle a challenging boulder-crater field with and without random attitude disturbances. In both cases the system avoided all five obstacles encountered. The path length without noise was 2.39 meters longer than straight line distance. The run with noise was even 0.7 meters shorter. In any case, System A appears to handle most boulder-crater fields with little problem, even when small rubble is present.

Only when rolling terrain is encountered does the performance of System A deteriorate. The run in Figure 28 shows the vehicle on rolling terrain of .25 meter amplitude and a 6.0 meter period. The vehicle initially started moving uphill but soon lost sight of the terrain in front of it due to the slope. This caused a sharp turn to be made, and since the vehicle continued to interpret the terrain as an obstacle, a very long path length resulted. Two backups occurred when all available paths were blocked by the system. Although the simulation terminated after 36 meters of travel, the vehicle was making some progress toward the target. It was at this point that the system began to break down.

System B (2 laser - 1 sensor)

With the need for more terrain data an additional laser was added for improvement in the system's performance. The first run of this system (Figure 29, path without noise) showed the system capable of reaching the target in a shorter total distance than System A had been able to. When attitude noise was added, the system became confused and six backups occurred, resulting in an automatic termination of the run, (Figure 29, noisy path).

System C (3 laser - 3 sensor)

This system demonstrates a dramatic improvement over the two previous systems. In Figure 30 the terrain is .25 meter amplitude, 6 meter period sine

TABLE I. Test Terrains in the Order of Their Evaluation

System A (1 laser - 1 sensor)

- 1) Boulder - Crater field without attitude noise. (Figure 27)
- 2) Boulder - Crater field with 10 degree attitude noise. (Figure 27)
- 3) Sine wave based terrain, with 0.25 meter amplitude and 6.0 meter period; no attitude noise. (Figure 28)

System B (2 lasers - 1 sensor)

- 1) Sine wave based terrain with 0.25 meter amplitude, 6.0 meter period, and no attitude noise. (Figure 29)
- 2) Sine wave based terrain, 0.25 meter amplitude, 6.0 meter period, and 10 degree attitude noise. (Figure 29)

System C (3 lasers - 3 sensors)

- 1) Sine wave based terrain, 0.25 meter amplitude, 6.0 meter period, and 10 degree attitude noise. (Figure 30)
- 2) Boulder - Crater field on Sine wave based terrain of 0.25 meter amplitude, 6.0 meter period, and 10 degree attitude noise. (Figure 31)
- 3) Boulder - Crater field on Sine wave based terrain of 0.3 meter amplitude, 6.0 meter period, and 10 degree attitude noise. (Figure 32)

System D (memory - less)

- 1) Boulder - Crater field with no attitude noise. (Figure 33)

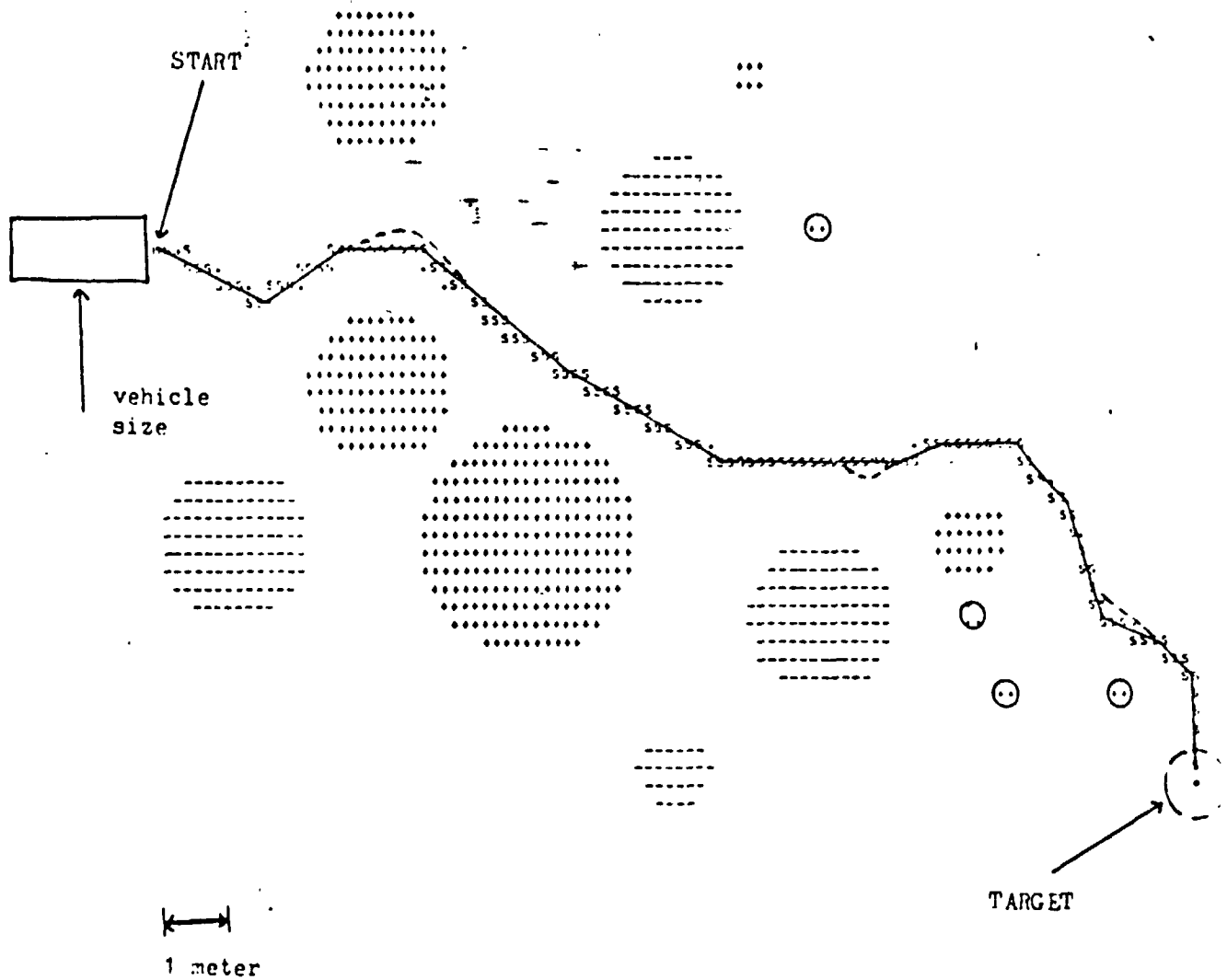

FIGURE 27

System A (1 laser - 1 sensor) encounter with boulder - crater field, with and without 10 degree attitude noise added. Dashed line marks the deviation in path caused by noise addition.

wave terrain with 10 degree attitude noise. The extra data made available by the additional sensed regions allowed the vehicle to distinguish the terrain as safe. The next terrain (Figure 31) shows the previous sine wave based terrain with the boulder-crater field of the system A tests superimposed. System C came surprisingly close to the duplication of the System A performance. Room for improvement is still quite apparent as Figure 32 shows. The terrain in this case was the same as in the last run except for the amplitude of the sine wave base being increased to .3 meters. Both Systems A and B have been tested on this terrain, and both have failed to traverse it. System C was able to do so, as long as the noise was absent. Addition of 10 degree attitude noise resulted in a completely confused system.

System D (memory-less)

The shortcomings of this type system are aptly illustrated in Figure 33. One sees the vehicle repeatedly encountering the same obstacle until finally working itself clear in a rather awkward manner. The situation reoccurs when the next obstacle is met. The problem seems to arise because of the backup maneuver. The system has no means to recall the extent of the obstacle previously encountered, and can therefore easily run into the same hazard again. Unfortunately, this characteristic seems to be indigenous to memory-less systems, and therefore this system is unsatisfactory.

The analysis of the short range laser-sensor triangulation system with memory indicates very good performance on most boulder-crater fields with flat based terrain, even when random attitude changes are present. This conclusion holds for the simplest system considered as well as the more complex. Rolling terrain appears to present severe problems particularly when the fundamental period is a small multiple of the vehicle's wheelbase. Long period rolling terrain causes no such degradation of performance. When random effects are included with the short period rolling terrain the difficulties are greatly magnified. Due to the relatively poor performance of the single laser-single sensor scheme, improvement was necessary.

Such improvement came in the form of increased system complexity. First, only one additional laser was employed, but eventually an expansion to three lasers and three sensors was deemed necessary to produce respectable performance on short period, rolling terrain.

Even the three laser-three sensor system encountered difficulties however. When the random attitude noise was included a great deal of wandering resulted. To minimize this problem, attitude information was taken into account. With knowledge of the vehicle's mean attitude and present instantaneous attitude, a decision could be made concerning the probable validity of the latest sensor readings. If the sensor was deemed invalid it could be corrected or, more simply, ignored. This technique did reduce false danger readings markedly without seriously impairing the data density, when applied only to inpath slopes.

The system designed without memory suffered due to its inability to remember the location of the obstacle which had been encountered. For this reason it tended to re-collide with the same obstacle several times in a row.

To further increase the performance of the short range laser-sensor triangulation system, several improvements are in order. More lasers and sensors should be employed, and various methods of logically combining their

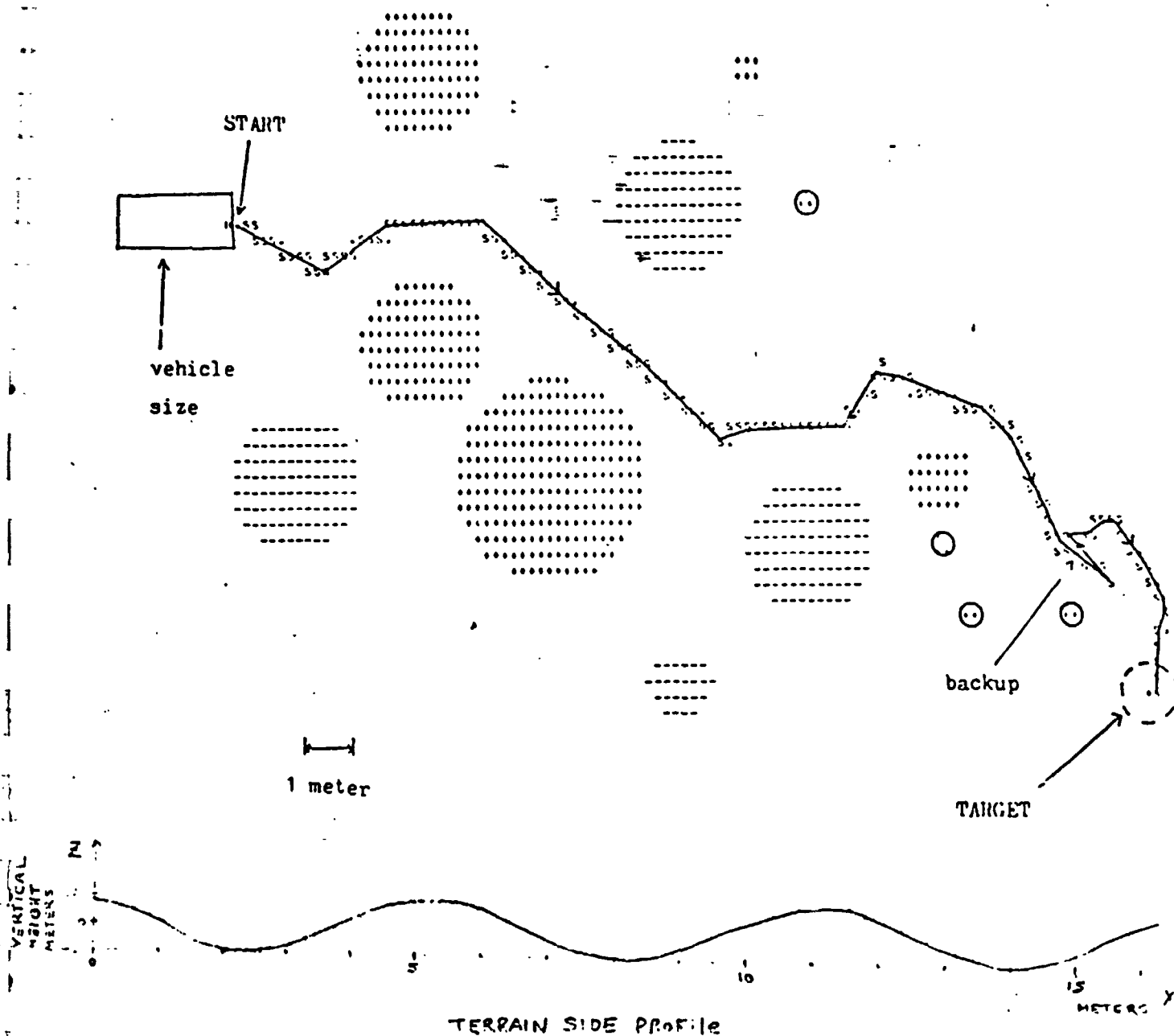

FIGURE 31

System C (3 lasers - 3 sensors) encounter with boulder - crater field superimposed on rolling, sine wave based terrain of 0.25 meter amplitude and 6.0 meter period; with 10 degree attitude noise added.

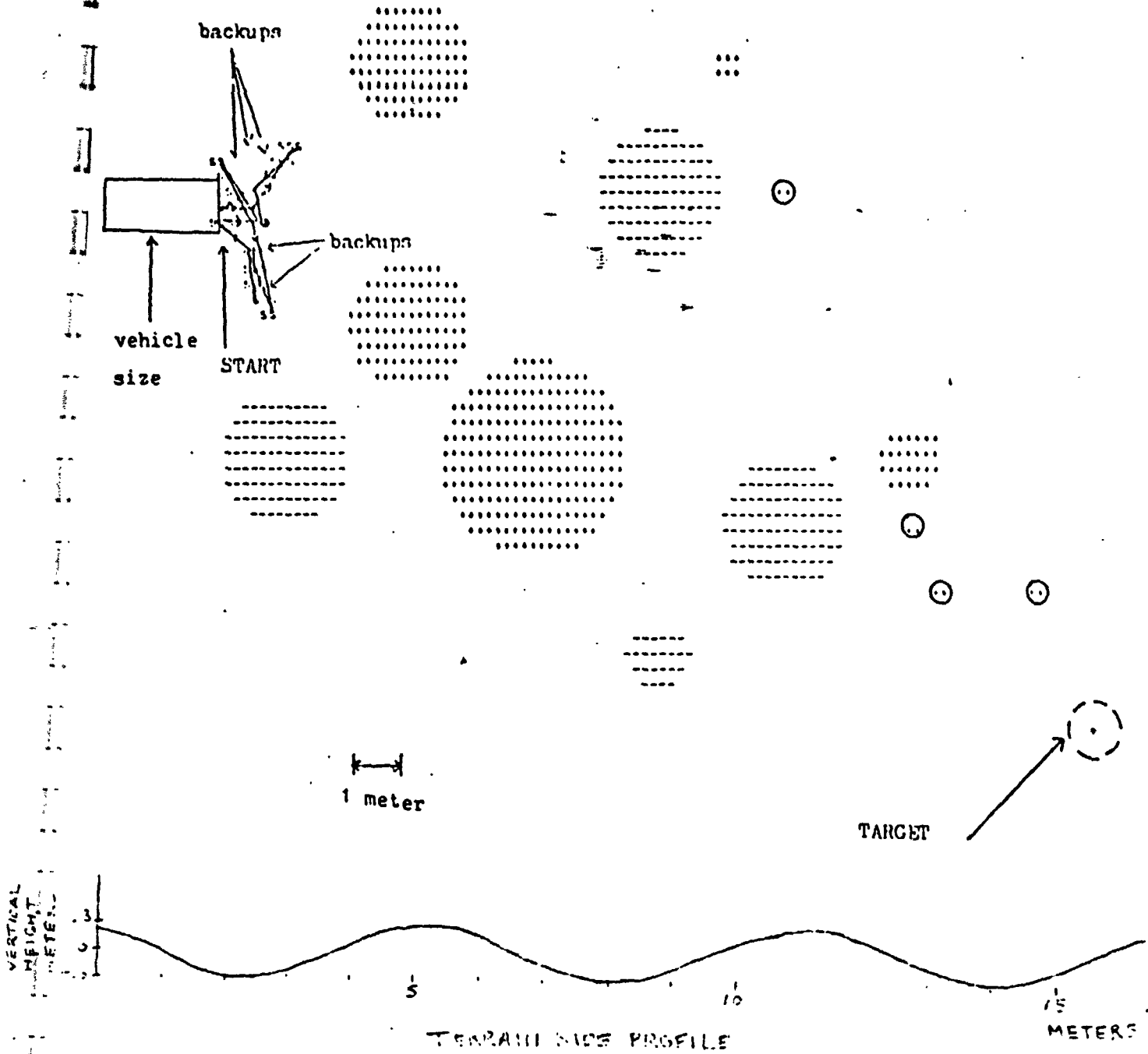

FIGURE 32

System C (3 lasers - 3 sensors) encounter with boulder - crater field superimposed on rolling, sine wave based terrain of 0.3 meter amplitude and 6.0 meter period; with 10 degree attitude noise added.

.....
 * VEHICLE PATH MAP
 * (UNSTABLE OVERLAY)

0.00 (METERS)
 2.00 (METERS)

5.00

9.26

12.00

16.51

20.00

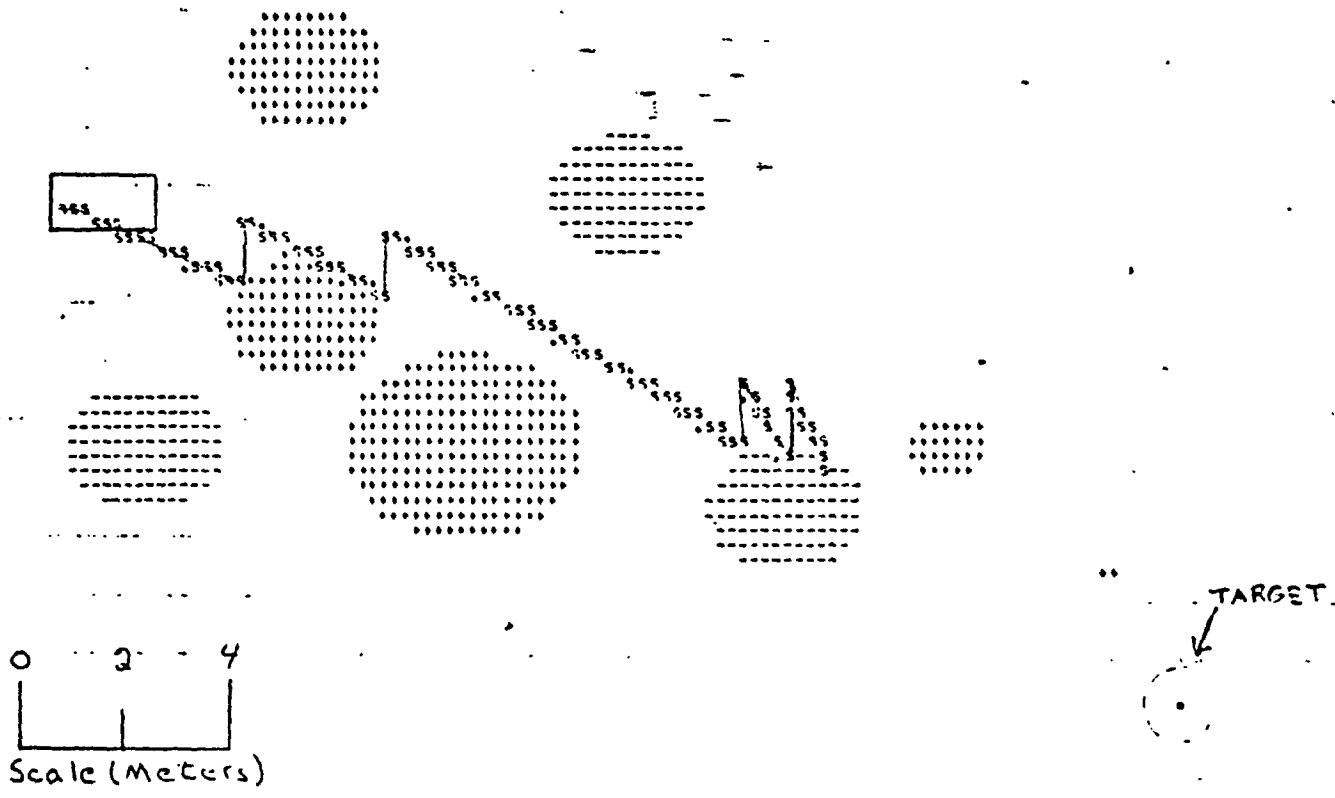

0 2 4
 Scale (Meters)

TARGET..

0.00 (METERS)
 2.00 (METERS)

5.00

9.26

12.00

16.51

20.00

- M INITIAL VEHICLE LOCATION
- S MID-RANGE SENSOR OPERATION
- VEHICLE PATH
- T TARGET LOCATION

FIGURE 33
 System D (memory-less system) encounter with boulder-crater field without attitude noise.

outputs to produce added terrain information be investigated. Additionally, vehicle attitude information should be taken into account and more sophisticated pattern recognition done.

Continuing efforts are underway to update the computer simulation package. This revision includes improved documentation and also a more realistic approach to the vehicle's dynamics. With these further improvements, the software package will become more efficient and provide a more factual simulation of the roving vehicle. Additional aspects of path selection systems based on these concepts are provided in References 3 and 10. A reprint of Reference 10 is provided in Appendix A.

TASK D. Advanced Terrain Sensing-Hazard Detection Concepts - K.L. Leung
Faculty Advisor: Prof. C. N. Shen

One major effort in this area has been devoted to the detection of discrete hazards such as boulders or craters using range pointing angle data as might be gathered by a laser rangefinder. Reference 11 describes in detail of edge enhancement using a method termed as the Rapid Estimation Scheme in conjunction with a Kalman filter. This task had as its goal implementation of this method on the Varian/620i IDIOM Interactive Graphics Computer System. The intent of this simulation is to provide investigators with increased capabilities in their efforts to develop effective hazard detection concepts. The rapid estimation scheme has been shown to be reliable in identifying the edges of positive and negative hazards provided that a sufficient data density is obtained. However, data requirements can be quite large depending on the sector covered and processing time can be substantial. Future efforts are planned to determine the extent to which the data requirements can be relaxed. This simulation which has been implemented on the graphics terminal gives the investigator a powerful weapon with which to approach this goal. Additional details of the rapid estimation scheme are provided in Reference 12. Reference 13, a reprint of which is included in Appendix A, describes the interactive graphics simulation in more detail.

REFERENCES

1. T. R. Geis, "Control Electronics for the Mars Roving Vehicle," Master of Engineering Project Report, Rensselaer Polytechnic Institute, Troy, New York, May 1976.
2. K. A. Fell, "The Telemetry Link and Computer Interface Designed for the Mars Rover," Master of Engineering Project Report, Rensselaer Polytechnic Institute, Troy, New York, December 1975.
3. M. J. Krajewski, "Development and Evaluation of a Short Range Path Selection System for an Autonomous Planetary Rover," Master of Engineering Project Report, Rensselaer Polytechnic Institute, Troy, New York, May 1976.
4. M. A. Mingoia, "Design and Implementation of Software for the Off-Board Computer Control of an Autonomous Planetary Rover," Master of Engineering Project Report, Rensselaer Polytechnic Institute, Troy, New York, May 1976.
5. Gisser, D.G., D.K. Frederick, P.K. Lashmet, G.N. Sandor, C.N. Shen and S. Yerazunis, "A Progress Report for July 1, 1974 to June 30, 1975 -- Analysis and Design of a Capsule Landing System and Surface Vehicle Control System for Mars Exploration," Rensselaer Polytechnic Institute, Troy, New York, July 1975.
6. Lipowicz, R.F., "A Wheel Design Analysis and Locomotion Study for the RPI Mars Roving Vehicle," Master of Engineering Project Report, Rensselaer Polytechnic Institute, Troy, New York, May 1976.
7. Marin, R.A., "Detection of Potential Terrain Features Hazardous to the Mars Rover Payload -- Feasibility of a Light Emitting Diode System," Master of Engineering Project, Rensselaer Polytechnic Institute, Troy, New York, May 1976.
8. Holly, D.H., "Terrain Sensing System (Laser Transmitter and Data Handler/Controller)," Master of Engineering Project Report, Rensselaer Polytechnic Institute, Troy, N.Y., May 1976.
9. Cairns, S.G., "Terrain Sensing System (Laser Receiver), Master of Engineering Project Report, Rensselaer Polytechnic Institute, Troy, New York, May 1976.
10. Yerazunis, S., D.K. Frederick and M. Krajewski, "Guidance and Control for an Autonomous Rover for Planetary Exploration," Proceedings of the 1976 Milwaukee Symposium on Automatic Computation and Control, Milwaukee, Wisconsin, April 1976.
11. Sonalkar, R.V., and C.N. Shen, "Simultaneous Bayesian Estimate of States and Inputs," Proceedings of the Joint Automatic Control Conference, Purdue University, Lafayette, Indiana, July 1976.

12. Sonalkar, R.V., "A Decision-Directed Rapid Estimation of States for Systems Subject to Unknown Input Sequences," Doctor of Philosophy Dissertation, Rensselaer Polytechnic Institute, Troy, New York, December 1975.
13. Leung, K.L. and C.N. Shen, "Simulation of Obstacle Detection Scheme for Mars Terrain Using Minicomputer," Proceedings of the Seventh Annual Modeling and Simulation Conference, Pittsburgh, Pa., April 1976.

APPENDIX A

Reprint A - Guidance and Control of an Autonomous Rover for
Planetary Exploration, S. Yerazunis, D. K. Frederick
and J. Krajewski

Reprint B - Simulation of Obstacle Detection Scheme for Mars
Terrain Using Minicomputer, K. L. Leung and
C. N. Shen

THE MILWAUKEE SYMPOSIUM ON AUTOMATIC COMPUTATION AND CONTROL

GUIDANCE AND CONTROL OF AN AUTONOMOUS ROVER FOR PLANETARY EXPLORATION

S. Yerazunis, D. K. Frederick and J. Krajewski

Rensselaer Polytechnic Institute
Troy, New York

A four-wheeled vehicle capable of dealing with irregular terrain features such as might be encountered in unmanned exploration of extraterrestrial bodies has been designed, constructed and tested. Its mobility and maneuverability are such that applications on earth requiring autonomous control may be served by it or a suitable variation. It could also serve as a test bed for artificial intelligence/robotics research. Alternative concepts for terrain sensing and modeling, and path selection algorithms have been investigated. A triangulation-based laser/photodetector path selection system developed by simulation is found to be able to deal with a broad range of terrain features. The path selection system is now in the process of construction and implementation and will permit field evaluation of the overall vehicle system as an autonomous rover.

INTRODUCTION

The very long term interests of man require that a thorough exploration of the planets of the solar system, their moons and the asteroids be undertaken eventually. Although it is likely that man himself will visit or establish himself ultimately on some of these extraterrestrial bodies, economic and technological considerations suggest that unmanned systems must be used during the shorter run.

Considerable knowledge of Mars, Venus, Mercury and Jupiter has been gained by fly-by or orbiter missions and more advanced remote sensor concepts will contribute further to man's understanding of the solar system. However, basic understanding of the chemical, biological, geological, meteorological and physical characteristics of extraterrestrial bodies requires surface exploration. The current Viking missions are intended to meet some of these requirements for the planet Mars.

Despite the historic implications of the Mars Viking program, Viking-type missions are severely limited in scope because of the

restricted sampling range of its ten foot boom with a 120° arc. Thus only a minute fraction of the martian surface will have been scrutinized and a larger but still very small fraction as limited by line of sight will be examined visually. A more thorough exploration is not likely to be effected by increasing the number of such stationary landers because of the large number which would be required and the problem of selecting and reaching precise landing sites where critical measurements can be made. A method for exploring the planet in question in detail and to do so adaptively on the basis of the knowledge being gained is essential.

The scenario for planetary exploration could involve either a stationary lander containing sophisticated and adaptable instrumentation for in-situ analysis or a sample return vehicle. In either case, the scenario must involve sample and/or data gathering devices capable of being relocated over much of the planetary surface, and in the case of sample gathering devices, capable of returning to the lander site. In order that such missions can be executed in a reasonable time of the order of several months to perhaps a year, such sample or data gathering devices must have a high level of both mobility and automatism.

The mobility requirements as expressed in terms of characteristics such as the maximum slope which can be climbed or descended, the maximum boulder which can be negotiated without avoidance, the ability to transverse depressions and very rough terrains, etc., has a direct bearing on the availability of paths to the desired sites. A vehicle of limited mobility may require an inordinate length of time and distance traveled to reach the target. Indeed, in some circumstances, the vehicle may not be able to reach the target. As the vehicle's mobility is increased, it will be able to deal effectively with increasingly difficult terrains. More paths to target will be available and the opportunity for selecting more optimal paths will be increased. Thus, one major research objective should be aimed at developing and evaluating alternative concepts of relocatable devices capable of serving a stationary lander or sample return mission.

Of equal importance to advanced exploration missions is the level of automatism which can be achieved. The decision for the vehicle to follow one path or another towards its destination must be provided by some path selection system comprised of appropriate terrain data

sensors, terrain modeler and path selection algorithm. The character and capabilities of such a system must be appropriate to the objectives of the mission. A low level path selection system will have to be biased conservatively to minimize the risk of an unperceived hazard in the vehicle's path. Thus many, perhaps all, acceptable paths towards the target may be excluded. The effect of a low level detection system is, in fact, to reduce the vehicle's mobility. As a minimum, the path taken towards the destination will be lengthier and the range of the exploration will be reduced. In the other extreme, the vehicle may become immobilized. On the other hand, a higher level, more sensitive, more perceptive path selection system will identify a larger fraction of the passable paths and will permit selection of those directions most compatible with the mission goals. Thus a second major research objective is the development of efficient path selection systems for the safe relocation of a rover.

The research program⁽¹⁾ aimed at these two major objectives is applicable not only to extraterrestrial exploration but to robotics applications on earth where hostile environments and special circumstances may exclude either direct or remote manual control. The major emphasis of this paper is on the rover and the path selection system selected for immediate implementation.

THE RENSSELAER ROVER

By virtue of its design the vehicle has a very high mobility and maneuverability, Ref. 1 and 2. In its deployed state, Figure 1, it has a stable stance allowing it to traverse very irregular terrain. The configuration of the struts serving the individually-driven wheels permits this vehicle to be collapsed into a compact space, Figure 2, from which it can be deployed automatically. The struts, which are driven separately by torsion bars, can be used to raise or lower the payload compartment as required and to orient it fore-and-aft with respect to the horizontal. The front wheel wagon steering insures that all four wheels will be in contact with the terrain for all but the most severe surface irregularities. It also permits a sharp turning radius such that in the extreme case, the vehicle can turn about a center through the rear wheel axles. The vehicle is able to deal effectively with a broad range of slope situations and discrete obstacles.

Perhaps the most outstanding feature of the design is that this vehicle can recover from the situation in which both front wheels fall over the edge of a crevasse or a deep crater. For all other vehicles which have been proposed, such an event would be catastrophic and would terminate the mission. That is not so with this concept.

(1) Faculty participating in the overall research program are: Profs. D.K. Frederick, D. Gisser, G.N. Sandor, C.N. Shen and S. Yezanis.

Because of the unequal lengths of the front and rear struts and the torsion bar system, the front and rear wheel assemblies can be reversed and the vehicle can withdraw safely from the hazard. This same maneuver can be used to extricate the vehicle from a "box canyon" or equivalent terrain feature in which there is insufficient room for the vehicle to turn itself around and from which it may not be able to back out. Previously proposed vehicles would also fail in this instance.

The vehicle has been refined to the point where it can serve as an exceptional test bed for the evaluation of alternative path selection systems. In this sense it is a valuable asset for exploring artificial intelligence or robotic aspects related to a machine seeking an acceptable path to a prescribed destination, an objective not necessarily restricted to extraterrestrial exploration.

In addition to the mechanical and propulsion systems, the rover is equipped with electronic four-wheel speed controls to permit effective steering, attitude and heading gyroscopes, position sensors for all major strut components, and a two-way telemetry link to an off-board mini-computer to provide the necessary vehicle data for guidance and control. All that remains is the implementation of the hardware and software required for an operating path selection system.

PATH SELECTION SYSTEM SIMULATION

The path selection system required to guide an autonomous vehicle must include: terrain sensor or sensors hardware, procedures for interpreting the data, and an algorithm for selecting safe paths on the basis of the data. The best combination of hardware and software will depend on the details of the mission and the dynamical and mobility characteristics of the vehicle or robot. An optimization of these requirements through an iterative process of constructing and evaluating specific hardware and software will be inordinately expensive and tedious and is not likely to be optimal. A digital computer simulation has been developed which can be used to screen all conceivable systems, Ref. 3 and 4. The simulation can "create" a very broad spectrum of terrains possessing such large and small scale details as desired. The pitching, heaving and rolling of the vehicle can be simulated and their effect on the terrain sensor data can be evaluated. The terrain sensor can be simulated to reflect both the error due to the motion of the sensor as a result of vehicular dynamics and the inherent sensor measurement errors. Proposed terrain modelers and path selection algorithms can be analyzed, evaluated and modified. When these considerations are taken all together, a first but meaningful appraisal of the strengths and weaknesses of proposed hardware systems can be obtained. Its application to a specific path selection system is described later in this paper.

ALTERNATIVE TERRAIN DATA GATHERING CONCEPTS

Efforts in developing alternatives for the gathering of terrain data have been focused on:

(a) a range-pointing angle concept and (b) a triangulation concept.

An in-depth study of the use of range-angle pointing data for terrain modeling and hazard detection has been on-going for several years. This phase, which has resulted in numerous publications, Ref. 5, 6, 7, 8, 9, 10, has focused on the mid-range problem from 3-30 meters. Methods have been developed for interpreting these data to obtain estimates of the terrain gradients and to detect discrete objects whose contours deviate from the main terrain. Edge detection and edge enhancement techniques have been developed which provide complete outlines of boulders, ridges, craters and crevasses provided that a sufficiently high data density is available. Current efforts are concentrating on the problem of reducing the data requirements without sacrificing the effectiveness of the interpretation. These studies are concerned with the data density in both time and space and to the implications of inherent sensor errors and errors due to the motion of the sensor as a consequence of vehicular dynamics.

As an alternative, a short range (1-3 meter) system based on triangulation has also been investigated. Indeed the latter system has been selected for implementation on the Rensselaer Rover. The concept is illustrated in Figure 3 in which are shown a laser beam along one pointing angle and a photodetector along a second pointing angle. The existence of a reflecting surface, i.e., terrain within the zone of intersection, will be sensed by the photodetector. In principle, any number of lasers and photodetectors can be deployed to obtain terrain surface data to any desired density and discreteness. This information can then be used as the basis for modeling the terrain and making path selection decisions.

From a terrain modeling point of view, the range-pointing angle and triangulation concepts are equivalent. That is, both concepts provide the same type of data in that the terrain surface is concluded to lie along a line segment of some length and angular orientation. However, the two concepts involve different technical obstacles in their implementation. The uncertainty of locating the terrain surface along the line segment using the range-pointing angle concept is determined by the ability of instrumentation to measure time-of-flight with possibly weak return signals and in the presence of undesired reflections. As one's objective in hazard detection focuses more on the short-range aspect, the time-of-flight measurement becomes increasingly difficult due to the need to measure extremely short time intervals. On the other hand, the uncertainty related with terrain location by triangulation is controlled by the geometrical relationship of the laser and the detector and the cone-of-vision of the latter. By using overlapping detectors and by scanning with a high frequency laser, the uncertainty can be made extremely small for the short range. However, the triangulation system begins to suffer inherent and significant uncertainty in long range applications. Thus, hardware systems based on range-pointing angle data look more attractive at longer ranges whereas the triangulation concept is far more favorable at short range.

Given the objective of demonstrating a minimal level of autonomous roving capability, it was concluded that a path selection system based on the triangulation concept would be implemented.

THE PROPOSED PATH SELECTION SYSTEM

As noted earlier, a path selection system consists of a sensor(s) to gather the data, a terrain modeler to process the data into a proper form, and a path selection algorithm to employ the modeled results with the objective of defining guidance commands. The path selection system which has been chosen for hardware and software implementation consists of two lasers scanned azimuthally along fifteen positions equally spaced at 10° to provide a 140° field of view. One photodetector possessing a 9.6° cone of vision will also be scanned over the same azimuthal angles. The two lasers will be located at a height of 1.5 meters at elevation angles of 43° and 46° whereas the photodetector at the 0.75 meter height will have an elevation angle of 62° , Figure 3. These initial design parameters are specified on the basis of the simulation studies completed to date. The mast on which the lasers and the photodetector are to be mounted has been constructed to provide up to 6 azimuthal 140° sweeps per second. The instrumentation mounting arrangements are such that the lasers can be scanned in elevation as well as azimuth and that additional photodetectors can be added as desired. Finally, the mast configuration will allow for significant adjustment of the geometric parameters so that the researchers will have considerable flexibility in studying more sophisticated triangulation-based alternatives.

Central to the task of demonstrating and evaluating this concept during the late spring of this year has been the path selection system simulation effort. It has fallen on this group to screen a number of design concepts and to synthesize a specific alternative satisfying the basic requirement that the rover will not pursue a path which will abort the mission and that if a safe path to the specified target exists the rover will eventually detect it. Although the long-term objectives call for a high degree of discrimination on the part of the system to minimize the misinterpretation of safe alternatives as hazardous, the studies completed to date have defined a minimum but feasible system.

The path selection system simulation, Ref. 4, has the capability of simulating the performance of a broad range of surface rover concepts, alternative data gathering concepts, data processors i.e. (terrain modelers) and path selection algorithms on a terrain selected by the user. The terrain can have large scale features as well as fine detail. Inherent sensors errors can be simulated along with those sensors errors due to the dynamic motion of the rover as it moves over highly irregular terrain and rubble. Thus, the simulation affords the users the opportunity to appraise alternative hardware and software concepts conveniently.

In the case at hand, the simulation was used to develop the design parameters specified above. The anticipated behavior of the selected system

is shown on Figures 4 through 8. Note that the design parameters are set to detect a positive hazard (boulder or step) or negative hazard (crater or trench) in excess of approximately $\pm 12''$ from the plane defined by the attitudinal status of the vehicle. With the single detector, this requirement is equivalent to setting the maximum gradient to $\pm 12^\circ$. Parenthetically, it might be noted that the 12° gradient is far lower than the actual slope climbing capability of the Rensselaer Rover. Thus this system will rule out potentially passable paths because of its inability to discriminate between slopes and discrete obstacles.

Shown in Figure 4 are the results of three simulations as applied to a boulder-crater field superimposed on a flat base using the single laser-single detector concept described earlier assuming the absence of noise due either to inherent sensor limitations or the pitch or roll vehicle motions. The proposed path selection system is found to be quite effective in dealing with this problem. Also shown in Figure 4 is a simulation of this system with vehicle motion noise effects equivalent to fluctuations of $\pm 5^\circ$ in pitch and $\pm 10^\circ$ in roll at the contact points of the wheels. At these noise levels, the path selection was unaffected.

The noise parameter referred to above is intended to account for the vehicle motion caused by terrain features which are too small to model on an individual basis. Random fluctuations in the pitch and roll angles are generated and then added to the vehicle's attitude as determined by the slope of the deterministic terrain under the vehicle. These random fluctuations are computed by entering a sequence of uniformly distributed random numbers into a second-order low-pass digital filter whose damping ratio and undamped natural frequency are representative of the vehicle's dominant mode. The purpose of the filter is to simulate the smoothing effect of the vehicle's suspension system. Roll and pitch are treated separately, with different random sequences. For example, using an unfiltered random sequence uniformly distributed over ± 10 degrees resulted in filtered angles having a standard deviation of ± 3.74 degrees and extreme values of ± 9.0 in the pitch direction. Hence, the excursions in the attitude of the mast and laser-detector combination are somewhat less than the unfiltered fluctuations which are assumed to exist at the wheel contact points. The standard deviation and the extreme values for other levels of vehicle dynamic noise would be proportional to these for 10 degrees.

Also shown in Figure 4 are simulations involving the two-laser system scheduled for implementation with noise levels of 10° and 15° in both pitch and roll. The performance of the system continues to be effective despite the high noise levels. However, it is clear that as the noise level due to vehicular dynamics and terrain irregularities is increased, a point will be reached eventually at which the effectiveness of the path selection system will be degraded. This question has not been fully explored yet because as will be described below noise effects are far more significant in terrain situations involving surface undulations than on flat base terrains.

Shown in Figure 5 are simulations involving a terrain described by sinusoidal functions. It should be noted that for a sinusoidal terrain of 6 meter period and 0.20 meter amplitude in the absence of noise that the path selection system is able to direct the vehicle in a straight line fashion between the initial point and the target destination. However, an increase of the amplitude to 0.3 meter forces the one laser hazard detection system to depart significantly from the straight line path and to meander toward the target. Although the target is reached eventually a considerably larger distance traveled is involved. The path selection system can be improved by adding a second laser at an incremental elevation of 3° . This modification has the effect of providing additional information which allows the path selection system to take a somewhat more direct route toward the target. However neither system can achieve a direct route for an amplitude of this magnitude. Increasing the amplitude to 0.33 meters while retaining the period at 6 meters, causes both the one and two-laser systems to prescribe an even more tortuous path. At an amplitude 0.4 meters, the system is unable to contend with the situations and fails to make progress towards the target. The simulations shown in Figure 5 highlight a major weakness in this simple hazard detection system, namely, its inability to distinguish between a slope and a discrete obstacle. The rover found itself obliged to turn from the direct path at critical points where the sensor was detecting the existence of a moderate slope in excess of the 12° limit imposed by the assumed sensor system. It had to take on a direction such that the gradient to be encountered would be within the specified tolerance limits. This is not necessarily a fatal flaw since the rover was able to select a trajectory either up or down hill which would be satisfactory. But it did so at the penalty of taking an unnecessarily long trajectory.

The consequences of dynamic noise are far more significant with respect to rolling terrain situations than in the case of the flat terrain on which a variety of boulder and crater obstacles are superimposed. This behavior is shown in Figure 6 in which the one-laser and the two-laser systems are tested in a .3 meter amplitude, 6 meter period sinusoidal terrain with noise due to vehicle dynamics equivalent to 10° in pitch and 10° in roll. In order to compare the two alternatives, the same seed was used to generate the random numbers which serve as the basis for calculating the noise. Thus, both systems were tested against the same exact sequence of dynamical motion. Both simulations failed to the extent that extreme meandering and confusion is observed. It cannot be concluded that the target would not have been reached ultimately because the simulations were automatically terminated on the basis of a time constraint. However, what is important to note in this comparison is that the two-laser system had no observable superiority over the one laser system in the case of this rolling terrain at this level of dynamical noise. Also shown in Figure 6 is the performance of the two laser system with vehicle dynamics noise reduced to 5° in pitch. Although a meandering path was followed, the system would ultimately lead the rover to the target.

Shown in Figure 7 are the results of three simulations all involving a rolling terrain described by a .25 meter amplitude, 6 meter period sinusoidal surface. Two of the simulations compare the effectiveness with which the one- and two-laser systems could deal with this rolling terrain situation in the presence of 10° pitch, 10° roll dynamical motion. Neither simulation proved to be particularly effective although the failure to reach the target is again a consequence of terminating the simulation rather than a fundamental inability to achieve the target ultimately. Nevertheless, in the case of this level of dynamical noise it is clear that the path selection system is forcing the rover into very substantial meandering and is therefore not considered effective for both the one- and two-laser systems although the latter appears stronger. However, the third simulation involving dynamical noise levels of only 5° in pitch but with the 10° roll retained showed that the two-laser system was able to take a relatively direct route from the starting point to the final destination. This suggests therefore that in the design of an autonomous rover a significant impact on the effectiveness of hazard detection and path selection systems can be obtained by careful vehicular design which minimizes the effect of dynamical noise upon the sensing devices. Another way of looking at the significance of these simulations is to note that it is the sum of the gradients representative of the physical terrain situation and of the noise effects which determine how well the path selection system will perform for a given vehicle. On the basis of the data at hand, it can be concluded that even with a 10° pitch noise due to dynamical motion that there would be some rolling terrain either with reduced amplitude and/or increased period which could be handled effectively by this system. In effect, the consequences of the noise associated with the dynamical motion is to reduce the mobility of the vehicle by applying a bias required to offset the impact of noise.

Summarized in Figure 8 are the results of three simulations in the absence of vehicle dynamics noise in which the boulder/crater field is superimposed on the sinusoidal rolling terrain. The combined terrain features are seen to pose a more serious problem than for either case separately. Case 1 involving the vehicle origin in the upper right hand corner found the vehicle getting itself into an awkward position in which a considerable amount of maneuvering was required before a good trajectory toward the target could be defined. The discontinuities in path, which are shown are a consequence of the simulation program which applies when the vehicle finds itself in an impossible situation. The algorithm calls for the vehicle to back up 1 meter. As far as the simulation is concerned this backup is instantaneous and discontinuous. Case 2 involving an initiation point in the upper left hand corner for a two-laser system proceeded rather well to the target whereas the corresponding path for the one-laser system encountered difficulty near the target and a considerable meandering before reaching the target. Also shown for comparison in Figure 8 is the path selection process for the boulder/crater field on a flat plane. It can be seen that the effect of the rolling terrain is to deny to the vehicle the most direct route to the target. However, the final simulation shown involving a

5° in pitch and 10° in roll vehicle dynamics noise closely parallels the path of the noiseless flat terrain case. It would appear that in this case, the noise led to a fortuitous selection of path.

Other simulations not reported herein have been conducted which suggest ways in which the system could be modified to deal more effectively either with the discrete obstacle such as boulders, craters, trenches or with slope characteristics. The tendency to interpret passable slopes as impassable can be reduced increasing the cone of vision of the detector. However, the effect of this action is to increase the size of the positive or negative discrete hazard to be interpreted as passable. A decrease in the cone of vision of the detector will permit smaller discrete obstacles to be detected but at the penalty of defining lower acceptable slope thresholds. The design parameters which have been selected as of this date represent what is believed to be the best compromise for the purpose of demonstrating and evaluating this kind of a system in hardware.

As noted earlier, the problem of noise due to vehicle dynamics has the effect of biasing the path selection decisions conservatively. The pitching or rolling motion of the vehicle provides false information which is interpreted as a vehicle hazard. It is also possible for the dynamical noise to give a false indication that a hazard is not present even though it really is. The latter does not prove to be significant because subsequent scans will disclose the existence of a real hazard, even though it may be overlooked on an individual scan. The reverse is not true; when a path is deemed to be blocked because of the dynamical noise, the path selection algorithm treats it as being blocked and not only directs the vehicle otherwise but retains in its memory that that path is blocked. Consideration is being given to incorporating memory into the terrain modeler and path selection algorithm so as to reduce the false identification of hazardous paths. Such a system should provide a basis for alleviating the type of erratic behavior shown in Figures 6 and 7.

The present path selection system has one additional major fault to which attention is being directed. Specifically, past researchers, Reference 11, have shown that a particular terrain feature may or may not be a hazard depending upon the main terrain characteristics on which the feature is located. Thus in the ultimate, it will be necessary to relate the state of the terrain, as defined by the attitude information provided by the attitude gyroscope mounted on the vehicle to the data being provided by the hazard detection sensors. One possible solution is to implement a higher level triangulation-based system which involves elevation as well as azimuthal scanning of the laser and an increased number of detectors with smaller cones or zones of vision. The effect of this type of a system is of course to decrease the coarseness of the information. Provided that a sufficiently fine mesh is obtained, pattern recognition techniques can be used to obtain a much more detailed and informative impression of the nature of the terrain in the path of the vehicle. The information gained in such a system could be tied to the

vehicle attitude data through appropriate mathematical relationships to provide a more sound decision as to whether the terrain feature is or is not a hazard for the vehicle's particular state.

Alternatively, one could consider using the basic system described herein but replicating it in sufficient number so that only one of the systems would be operational at a given time depending upon the vehicle's attitude. Thus, one might have a multi-unit system of the type described herein with the central unit applying to all situations in which the vehicle's attitude is not far removed from horizontal, with the immediately adjacent two units applying when the vehicle's attitude is slightly upwardly or downwardly inclined, and with additional adjacent units applying at greater and greater attitudinal deviations from horizontal. The number of such units would depend on the need for refined terrain information.

Consideration is being given to other systems of intermediate complexity, namely, five 90° detectors overlapped as to produce nine discrete signals in combination with from three to five lasers being scanned azimuthally but with each laser at a very specific elevation. Such an intermediate system can be implemented in hardware and software relatively easily and have the advantage of providing enough added information to give the path selection algorithm a more reliable basis for decision making.

As of this writing, the research program to produce the required hardware, (i.e. lasers, photodetectors, scanning mast, etc.) and to program the software in a IDIOM Graphics-Varian Computer, which is to serve as the data processor, are proceeding vigorously. The rover itself and its on-board control systems and actuators are operational along with the telemetry systems required to transmit data from the vehicle to the computer and vice versa. It is anticipated that all systems will be active in the neighborhood of April 1, and that laboratory and field research will be undertaken shortly thereafter.

CONCLUSIONS

1. A path selection system based on a two-laser/one-detector terrain sensor can be effective in guiding an autonomous rover over terrains whose general slopes are less than $\pm 12^\circ$ and on which are distributed discrete hazards larger than ± 12 inches in the presence of vehicle dynamics noise of the order of $\pm 5^\circ$ in pitch and $\pm 10^\circ$ in roll.
2. The performance of such a system can be increased provided that the state (i.e. the attitude) of the vehicle is taken into account in the interpretation of the sensed terrain data and that additional attitude dependent sensor units are added.
3. Terrain sensors based on triangulation provide a basis for developing short-range path selection systems capable of dealing with very complex terrain situations.

ACKNOWLEDGEMENT

The authors acknowledge gratefully the critical contributions of Dr. G. N. Sandor and his student research assistants who designed and constructed the rover and its associate electro-mechanical systems.

The technical guidance and recommendations provided over past years by Dr. G. Payne and Mr. B. Dobrotin of the Jet Propulsion Laboratory and by Mr. P. Tarver of the Office of Lunar and Planetary Studies of NASA are deeply appreciated.

The authors also acknowledge the generous and extended support of the Office of Lunar and Planetary Studies of the National Aeronautics and Space Administration through Grant NGL 33-018-091.

REFERENCES

1. Rayfield, W.P., and Sandor, G.N., "Design of Roving Vehicle for Mars," Invited Paper, presented at the ASME Design Engineering Conf., New York, N.Y., April 19-22, 1971.
2. Sandor, G.N., "Seven Dangers of Designer Overspecialization and How to Avoid Them By Designer Education," Invited ASME Paper No. 74-DE-35, 1974 Design Engineering Conference, Chicago, April 1-4, 1974, to be preprinted by the ASME in full and to be published as abstract in Mechanical Engineering, Journal of the ASME.
3. Campbell, R.S. and Simonds, R.R., "Path Selection System Development and Evaluation for a Martian Roving Vehicle," RPI Technical Report MP-42, Rensselaer Polytechnic Institute, Troy, N.Y., May 1974.
4. Frederick, D.K., "Path Selection System Simulation and Evaluation for a Martian Roving Vehicle," 6th Annual Pittsburgh Conference on Modeling and Simulation, Pittsburgh, Pa., April 1975.
5. Shen, C.N. and Burger, P., "Stochastic Estimates of Gradients from Laser Measurements for an Autonomous Martian Roving Vehicle," Proceedings of 3rd IFAC Symposium, The Hague, June 1973.
6. Shen, C.N. and D'Angelo, R.P., "Parameter Estimation for Terrain Modeling from Gradient Data," 7th Hawaii International Conference on System Sciences, Hawaii, January, 1974.
7. Shen, C.N. and Thompson, A., "Computer Results of Two-Dimensional Spline Function in Terrain Modeling Optimization," ACM 1975 Computer Science Conference, Washington, D.C., February 1975.
8. Reed, M., Sanyal, P. and Shen, C.N., "A Practical Obstacle Detection System for a Mars Rover," Proceedings of the Milwaukee Symposium on Automatic Controls, March 1974, Milwaukee, Wisconsin.

THE MILWAUKEE SYMPOSIUM ON AUTOMATIC COMPUTATION AND CONTROL

9. Shen, C.N. and Sonalkar, R.V., "Mars Obstacle Detection by Rapid Estimation Scheme from Noisy Laser Rangefinder Readings," Milwaukee Symposium on Automatic Computation and Control, Milwaukee, Wisconsin, April 1975.
10. Shen, C.N. and Sher, J.S., "Simulation of the Range Data and the Picture Enhancing Scheme for a Mars Rover," ACM 1975 Computer Science Conference, Washington, D.C., February 1975.
11. Shen, C.N., Leung, K.L. and Yerazunis, S., "Classification of Terrain Models for a Martian Vehicle," 6th Annual Pittsburgh Conference on Modeling and Simulation, Pittsburgh, Pa., April 1975.

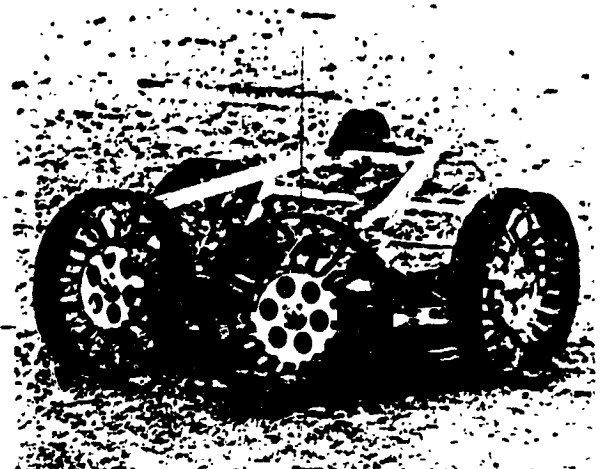

Figure 2. The Rensselaer Rover in its Deployed Configuration

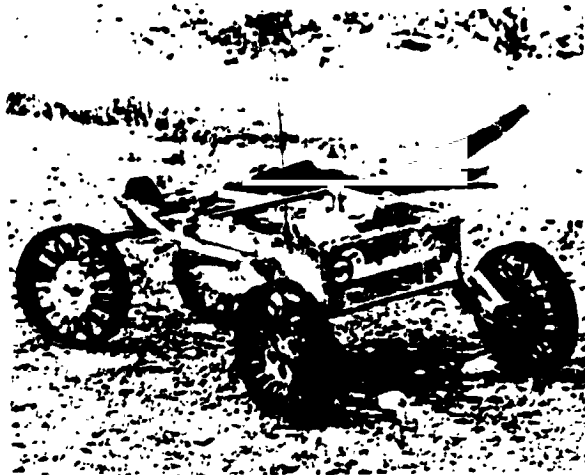

Figure 1. The Rensselaer Rover in its Collapsed Configuration

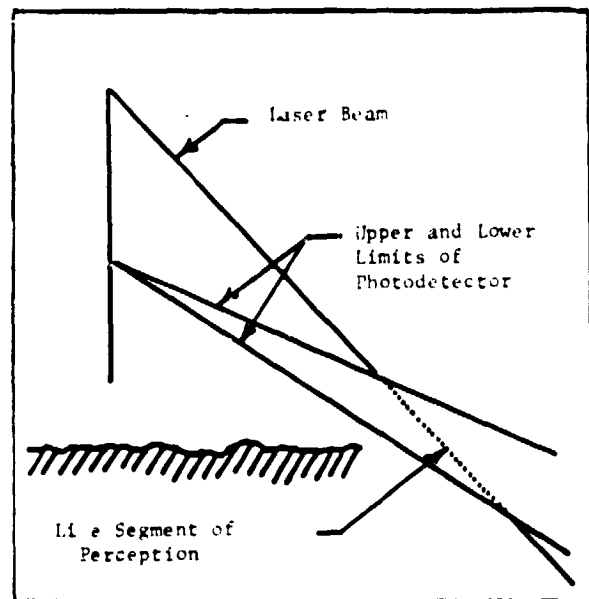

Figure 3
Terrain Detection by Triangulation

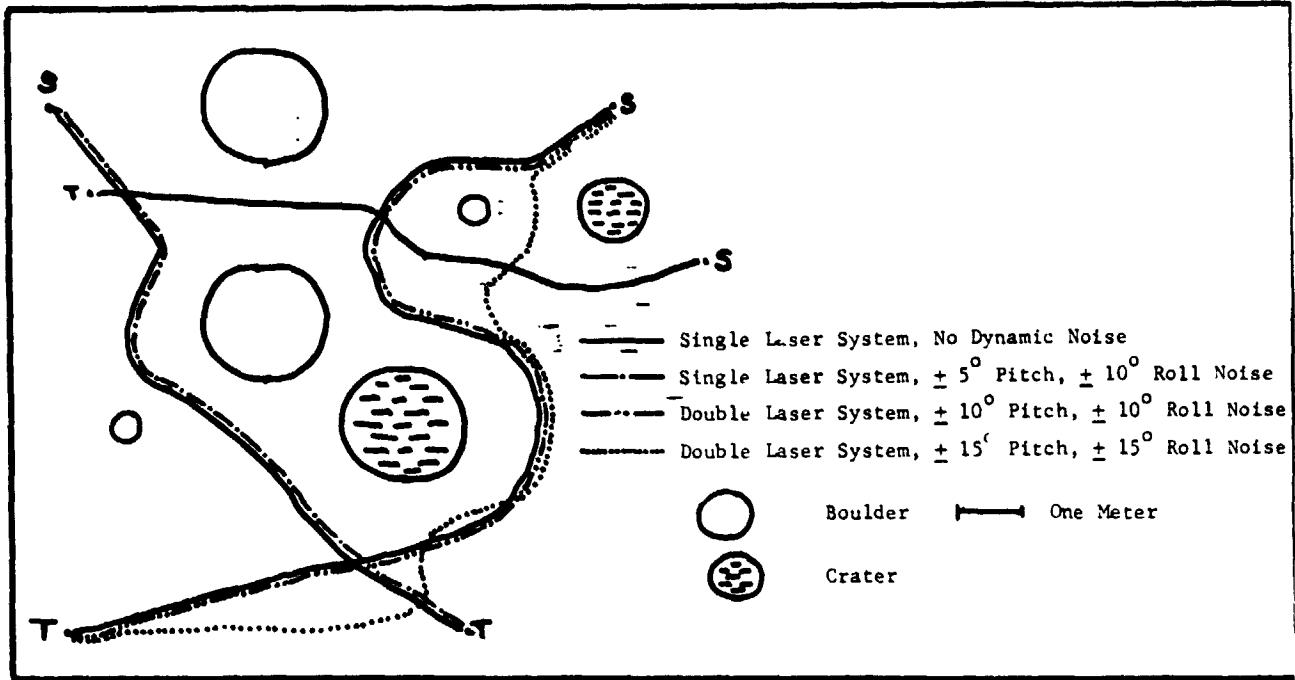

Figure 4. Path Selection Simulation Through a Boulder/Crater Field on a Flat Base Terrain

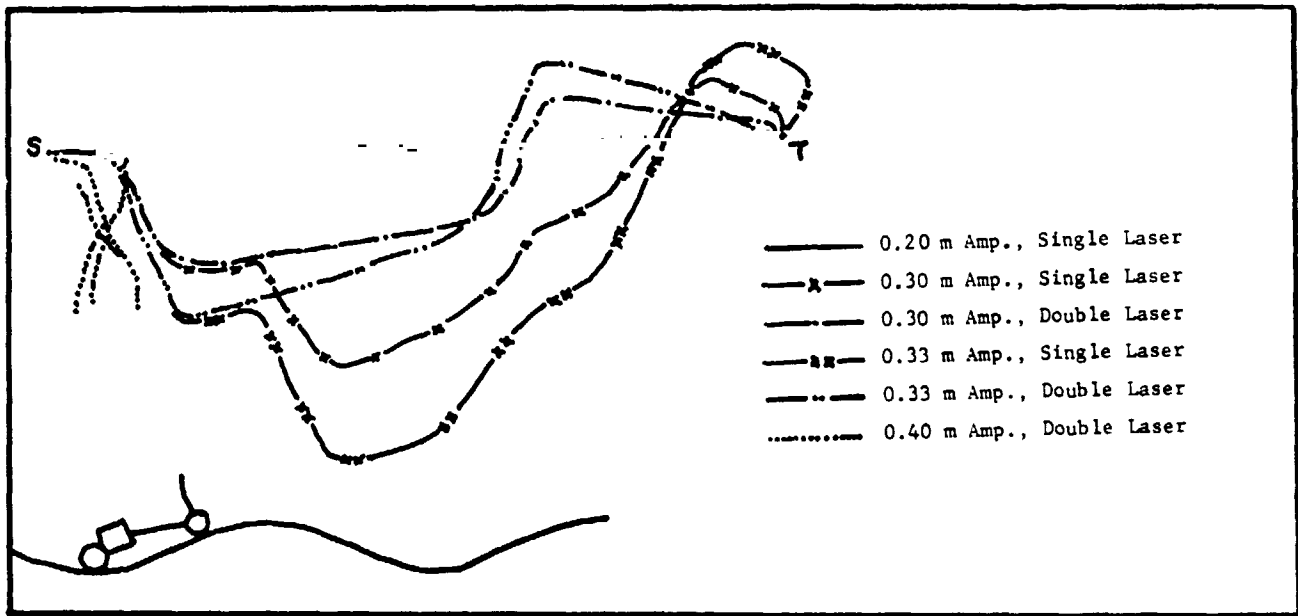

Figure 5. Path Selection Simulation Over a 6.0 Meter Period Sinusoidal Terrain in the Absence of Vehicle Dynamics Noise

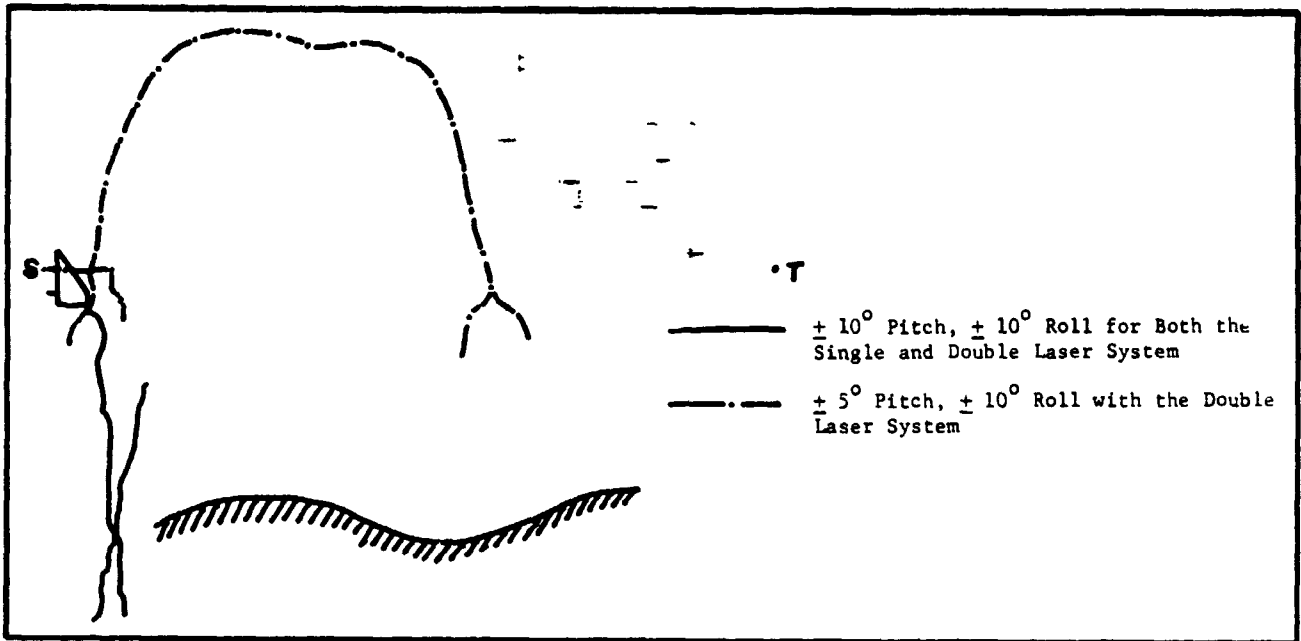

Figure 6. Path Selection Simulation for a Sinusoidal Terrain 0.3 Meter Amplitude and 6.0 Meter Period in the Presence of Vehicle Dynamics Noise

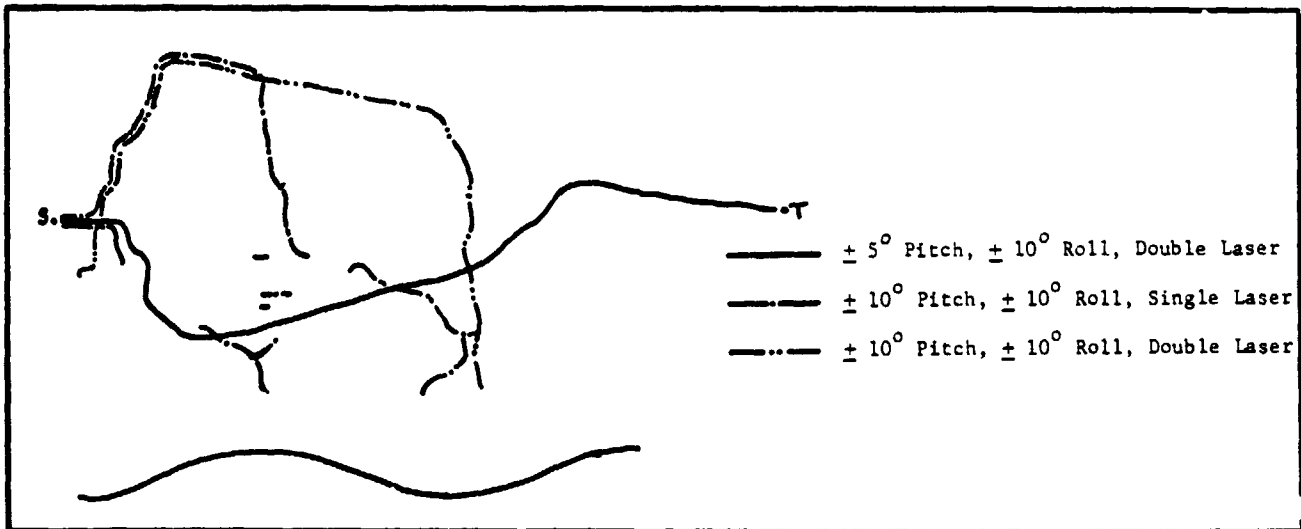

Figure 7. Path Selection Simulation for a Sinusoidal Terrain of 0.25 Meter Amplitude and 6.0 Meter Period in the Presence of Vehicle Dynamics Noise

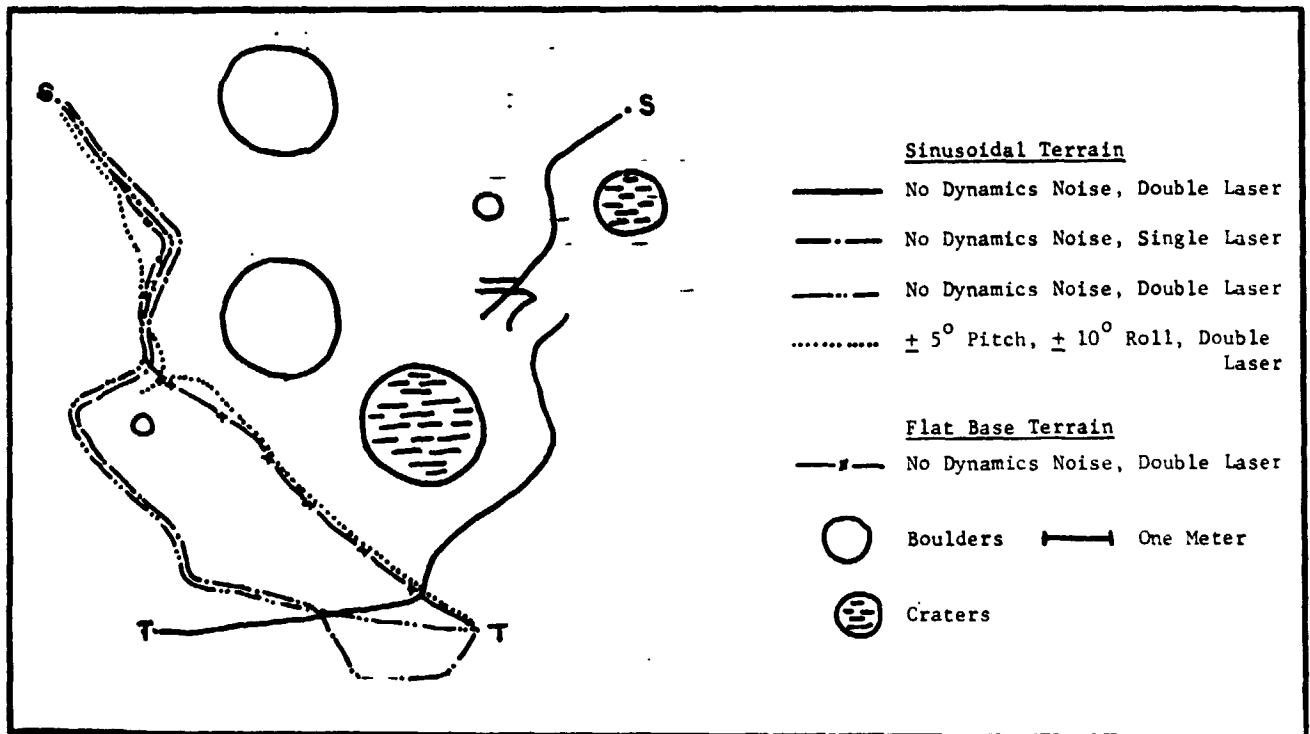

Figure 8. Path Selection Simulation for a Boulder/Crater Field Superimposed on a Sinusoidal Terrain of 0.3 Meter Amplitude and 6.0 Meter Period

PRESENTED AT THE SEVENTH ANNUAL CONFERENCE ON MODELING AND SIMULATION, PITTSBURGH, PA., April 1976 and Published in the Proceedings of the Conference

SIMULATION OF OBSTACLE DETECTION SCHEME FOR MARS TERRAIN USING MINICOMPUTER*

K. L. Heung and C. N. Shen**
Rensselaer Polytechnic Institute
Troy, New York 12181

ABSTRACT

Simulation for detection of obstacles on Martian Terrain is achieved by a rapid estimation scheme on Varian Data 620/i computer with IDIOM display. Sufficient information can be obtained to recognize the near and far edges of pyramids, hemispherical craters or boulders, and the combination thereof.

INTRODUCTION

An autonomous roving vehicle is to be sent to Mars for future exploration^[1]. A laser rangefinder having an accuracy of ± 10 centimeters, will scan an area ahead of the rover. An obstacle detection scheme will therefore be needed to process these range data to obtain complete outlines of distinct objects.

One detection scheme that has been developed by Reed, Sanyal and Shen^[2] makes use of the four-directional Laplacian method. This scheme works well in detecting top edge of a boulder and near edge of a crater but it fails to detect the bottom edge of a boulder and the far edge of a crater. The scheme can only detect large jumps in ranges, but not large jumps in slopes.

The above scheme was simulated on both the IBM 360/67 computer and the Varian Data 620/i computer by Sher and Shen^[3]. On both computers, the range data were generated by a searching scheme and then Gaussian noise was added to the range data to simulate the actual range. In the simulation with the Varian Data computer, an IDIOM graphic cathod-ray tube was employed to display the parameters, the topview of obstacle layout and the results for edge image. A light pen was also used by the operator to interrupt the display and to change the parameters.

Another obstacle detection scheme was developed by R. V. Sonalkar and C. N. Shen^[4] which uses a Rapid Estimation Scheme^[5,6] (R.E.S.) in conjunction with Kalman Filter. In the simulation on the IBM 360/67 computer, their scheme was shown to work extremely well in detecting complete edges of

boulders, craters, and other obstacles.

OBJECTIVE

The objective is to evaluate the performance of the obstacle detection scheme on a minicomputer. This paper simulates the Sonalkar-Shen Obstacle Detection Scheme on the Varian Data 620/i computer, making use of Sher and Shen's display subroutines for parameter, topview, and edge image displays.

The reason for this simulation is two-fold. Firstly, this enables easy parameter changing with light pen and teletype. Topviews of obstacles and the resulting edge images can be seen and the differences observed. The operator will then change the parameters accordingly and repeat the simulation. This means that the simulation can be done adaptively.

Secondly, the possibility of implementing this scheme on a small computer such as the Varian Data must be ascertained.

EQUATIONS FOR OBSTACLE DETECTION

The range data are given by the matrix R with the following elements:

$$R = \begin{matrix} & \begin{matrix} \rightarrow & j & \rightarrow \end{matrix} \\ \begin{matrix} \uparrow & i & \uparrow \end{matrix} & \begin{bmatrix} r_{i1} & \dots & r_{i2} & \dots & \dots & r_{in} \\ r_{i-1,1} & \dots & r_{i-1,2} & \dots & \dots & r_{i-1,n} \\ \dots & \dots & \dots & r_{i+1,j} & \dots & \dots \\ \dots & \dots & \dots & r_{ij} & \dots & \dots \\ \dots & \dots & \dots & r_{i-1,j} & \dots & \dots \\ r_{i1} & \dots & r_{i2} & \dots & \dots & r_{in} \end{bmatrix} \end{matrix} \quad (1)$$

where r_{ij} is the range data for the terrain, the length of the Laser beam from the ground. The indices i and j indicate the location in the angle of elevation, θ_i , and azimuth angle, θ_j . The quantity r_{ij} is the sum of the actual distance between the transmitter and the point on the ground

* Research sponsored by NASA Grant, NSG-7184
** Professor-Electrical & Systems Engineering Dept.

and the Gaussian noise due to the inaccuracy of the laser rangefinder. Hence

$$r_{ij} = d_{ij} + v_{ij} \quad (2)$$

The range matrix R is processed both along all columns and across all rows. When processed vertically up a column, it is expected to detect jumps in both range and in slope, a two-dimensional state vector is defined. The first component is the range d_i and the second is the difference in successive range data g_i (slope) where

$$g_i = d_{i+1} - d_i \quad (3)$$

The quantities g_i , d_i , β are illustrated in Figure 1, θ is illustrated in Figure 2.

Along a column, the j index is held constant. The state equation is given as follows by omitting the index j .

$$x_{i+1} = F_i x_i + w_i + B u_k \delta_{ik} \quad (4)$$

The measurement model is:

$$r_{i+1} = H x_{i+1} + v_{i+1} \quad (5)$$

where

$$x_i = \begin{bmatrix} d_i \\ g_i \end{bmatrix}; \quad F_i = \begin{bmatrix} 1 & 1 \\ 0 & f_i \end{bmatrix}; \quad H = [1 \quad 0] \quad (6)$$

$$B = \begin{bmatrix} 0 \\ 1 \end{bmatrix}; \quad u_k = \text{jump in } \epsilon_k \text{ due to an edge} \quad (6)$$

It can be shown that for a flat plane,

$$f_i = \frac{1 + \Delta\beta \tan \beta_i}{1 - 2\Delta\beta \cot \beta_i} \quad (7)$$

$$\text{Also } \delta_{ik} = \begin{cases} 1 & \text{for } i = k \\ 0 & \text{for } i \neq k \end{cases} \quad (8)$$

which is a Kronecker delta function.

Vectors w_i and v_i represent plant and measurement noise respectively. The quantity w_i accounts for the deviation of the model from the actual state equation. The quantity v_i accounts for error in the rangefinder.

RANGE DATA AND NOISE GENERATION

The surface of each obstacle within the scanned area is described by its own geometric equation

$$f(x,y,z) = 0 \quad (9)$$

If the point on the ground right underneath the laser mast is taken as the origin, then a level plane with no obstacle is described by $z=0$.

To determine the range reading with azimuth angle θ , and angle of elevation β , imagine a laser beam at these angles. The height H and (x,y) coordinates of a point on the beam a small distance away from the laser rangefinder is calculated and this height is compared with the height z of the terrain with the same (x,y) coordinates. If H is greater than z , then H of the point one increment down the beam is calculated and compared with z of the corresponding (x,y) . The procedure is repeated until z is greater than H . Using a bisection

method, the (x,y) coordinates of the point where the beam hits the terrain is determined. If the height of this point is z^* and the height of the rangefinder is D , then the true range reading d_{ij} is given by

$$d_{ij} = (D - z^*) / \sin(\beta_i) \quad (10)$$

Note that if the beam does not hit any obstacle, $z^*=0$ and

$$d_{ij} = D / \sin \beta_i \quad (11)$$

These are illustrated in Figures 2 and 3.

CAPACITY OF MACHINE

The computing machine used in this simulation is the Varian Data 620/i. The memory of this computer when expanded, is a limiting 32767 words, or roughly 32K. The operating system used in this computer takes up about 4K. Hence the available memory is only 28K. For comparison, the memories required by the various programs are tabulated on Table 1.

	Sonalkar Shen on IBM 360/67	Sher- Shen on Varian	Leung- Shen on Varian
Rapid Estimation Scheme	8K		
4-directional w/o Display		22K	
4-directional w/ Display		28K	
R.E.S. w/Display by combining Sonalkar and Sher			34K
R.E.S. w/Display after Improvement			27.5K

TABLE 1

The Memory Requirements of Various Programs

TECHNIQUES USED IN COMBINING THE PROGRAMS

The original Sonalkar-Shen program that simulates the Rapid Estimation Scheme was written in Fortran suitable for the IBM computer, which has a great deal of convenient features not found in the Varian computer. In order to run this program on the Varian machine, those convenient features must be changed to standard FORTRAN.

After the two programs are made compatible, the four-directional Laplacian obstacle detection part in the Sher-Shen program is taken out, and the Sonalkar-Shen program, i.e., The Rapid Estimation Scheme, is put in.

Each of the two original programs is very long by itself. After they are combined, the resultant program is too long and requires too much memory, 34K. Hence it must be improved by reusing some memory spaces after the numbers that are stored in these spaces are used. That is to say, two or more variables share the same memory space because they are stored in that space at different non-overlapping instances of time during the execution. This only accounts for a small amount of memory saved. The major reduction in the memory requirement is achieved by storing the noiseless range matrix and noisy range matrix in the same memory spaces.

Moreover, the spaces set aside for the noise matrix

in the original program is eliminated. Hence the noise is added to the noiseless range reading as it is generated and the resulting noisy range reading is put back in the same space, therefore erasing the noiseless reading. Here memory saving does not come at no expense because the noiseless range matrix and noise matrix can be retrieved as two separated matrices from the noisy range matrix.

PROCEDURE OF SIMULATION

The IDIOM displays three separate pictures, the specification, the top view of the layout and the edge enhancement. If no interruption occurs in the display process, the Varian 620/i will use the initial parameters for all calculations. The light pen is used to interrupt the processing by pointing at the parameter that one desires to change. The new value of this parameter is entered through the teletype. The Varian 620/i will then use the new data and continue the processing. The picture on display can be replaced by another picture by pointing the light pen at the appropriate character.

The inputs to the computer are the dimensions and locations of the obstacles (the dimensions of the obstacles not used will be zero), the height and location of the laser rangefinder, the maximum and minimum azimuth angles, the maximum and minimum angles of elevation, and the standard deviation of the Gaussian noise used. The above input parameters have initial values as specified in Figure 4(a). They can be changed through the use of the light pen and the teletype.

With the input parameters, the program then displays the top view of the obstacle layout on the IDIOM. When the display is interrupted by the light pen, the program then calculates the range data using Eq.'s (10) and (11).

With the noisy range data and the noise covariance, the program processes the range data to detect the complete edges of the obstacles, using the Rapid Estimation Scheme, i.e., Eq.'s (1) through (8). Eleven cases are simulated. The values of the inputs for each case are shown in Table 2.

NUMERICAL RESULTS AND DISCUSSION

Eleven cases were simulated. Each case is a different combination of obstacle sizes, locations, and noise parameters. Some have single obstacle and some have multiple obstacles. For each case, the parameters, topview, and edge enhancement are displayed. The values of different parameters are shown in the parameter display. The layouts of the obstacles are shown in the topview displays and the edge enhancement results, i.e., the edge images, are shown in the edge enhancement displays. The parameters are chosen to illustrate the effects of the change of noise covariance, obstacle sizes, and the distance between obstacles and laser for use in the Rapid Estimation Scheme. Some of these eleven cases are shown in Figures 4-10.

In Figure 4(c), case No. 1, only the top edge of the 1 meter radius hemispherical boulder at 10 meters from the laser rangefinder (L.R.F.) can be

detected because the obstacle is too close to the L.R.F. and hence the signal-to-noise ratio (SNR) is small with 5 cm. noise standard deviation. In case No. 2, the noise standard deviation is increased to 10 cm. and everything else is the same as in case No. 1.

In Figure 5, case No. 3, the complete edge of the boulder at 20 m. from L.R.F. is detected for noise with standard deviation equal to 5 cm. In case No. 4 and case No. 5, the simulation is repeated for case No. 3, except that the noise standard deviation is now 10 cm. and 20 cm. respectively. The performance is very good. In Figure 6, case No. 6, the complete edge of a 1 m. radius hemispherical boulder at 30 m. from L.R.F. with a noise standard deviation of 5 cm. is detected. The edge enhancement result is better than that of the same boulder with the same noise at 20 m. from L.R.F. In case No. 7, the noise standard deviation σ_n is increased to 20 cm. In this case, the bottom edge is not so well defined. Case number 8 is a hemispherical crater with 1.5 m. radius at 12 m. from the rover, with σ_n equal to 5 cm. The far and near edges of the crater are detected but some noisy edges are picked up in the background.

Figure 7, case No. 8, is an equilateral pyramid of height 1 m. at 20 m. from the rover, with σ_n equal to 5 cm. and 10 cm. respectively. Here R.E.S. does not work too well. The top of the pyramid gets truncated.

Case No. 10 (Fig. 8) and case No. 11 respectively are multiple obstacles having a hemispherical boulder, a hemispherical crater, and a pyramid with their sizes and locations shown in the topview and parameter displays. The σ_n in case No. 10 and 11 are 5 cm. and 10 cm. respectively. Complete edges of all three obstacles are detected for the case with a smaller σ_n . For the case with a larger σ_n , the far edge of the crater and the bottom edge of the pyramid are not detected.

CONCLUSION

It can be concluded that the Rapid Estimation Scheme works very well in detecting complete edges of obstacles if the obstacles are far enough from the laser rangefinder ($>$ about 15 meters) and the noise standard deviation is not too large ($<$ about 10 cm. This scheme can still detect top edge of boulder and near edge of crater if the obstacles are too close and noise standard deviation is larger than 10 cm. Therefore, the Rapid Estimation Scheme is equivalent to or better than the four-directional Laplacian scheme in performance. However, the former scheme needs slightly more computation than the latter. Therefore, the R.E.S. extracts more information from the noisy range matrix if the slightly larger number of computation is allowable.

REFERENCES

1. Jet Propulsion Laboratory, "An Exploratory Investigation of a 1979 Mars Roving Vehicle Mission", JPL Reports, 1970.
2. M. Reed, P. Sanyal and C.N. Shen, "A Practical Obstacle Detection System for the Mars Rover",

Proceedings of the Milwaukee Symposium on Automatic Control, Mar. 1974, Milwaukee, Wis.

3. J. S. Sher and C.N.Shen, "Simulation of The Range Data and The Picture Enhancement Scheme For The Mars Rover", 1975 Computer Science Conference, University of Maryland.
4. R.V.Sonalkar and C.N.Shen, "Mars Obstacle Detection By Rapid Estimation Scheme From Noisy Laser Rangefinder Readings", Proceedings of the Milwaukee Symposium on Automatic Control, March 1975, Milwaukee, Wis. pp 291-296.
5. P. Sanyal and C.N. Shen, "Bayes Decision Rule for Rapid Detection and Adaptive Estimation Scheme with Space Applications", IEEE Transactions on Automatic Control Vol. AC-19, No. 3, June 1974, pp 228-231.
6. R.V.Sonalkar and C.N.Shen, "Rapid Estimation and Detection Scheme for Unknown Discretized Rectangular Inputs", IEEE Transactions on Automatic Control, Vol. AC-20, No.1, Feb. 1975.

TABLE 2 Values of Input Parameters

Case No.	Location (x,y) in Meters			Height of in Meters		Radius of in Meters		Angle in Degrees				Stand. Deviation of noise in cr.	shown in Fig.
	of Pyramid	of Boulder	of Crater	range-finder	Pyramid	Boulder	Crater	Max. Azimuth	Min. Azimuth	Max. Elevation	Min. Elevation		
1	(-1,0)	(0,10)	(1,0)	3.0	0.0	1.0	0.0	7.0	-7.0	19.6	10.0	5.0	4
2	(-1,0)	(0,10)	(1,0)	3.0	0.0	1.0	0.0	7.0	-7.0	19.6	10.0	10.0	n.s.
3	(-1,0)	(0,20)	(1,0)	3.0	0.0	1.0	0.0	4.0	-4.0	9.0	5.0	5.0	5
4	(-1,0)	(0,20)	(1,0)	3.0	0.0	1.0	0.0	4.0	-4.0	9.0	5.0	10.0	n.s.
5	(-1,0)	(0,20)	(1,0)	3.0	0.0	1.0	0.0	4.0	-4.0	9.0	5.0	20.0	n.s.
6	(-1,0)	(0,30)	(1,0)	3.0	0.0	1.0	0.0	3.0	-3.0	6.6	3.0	5.0	6
7	(-1,0)	(0,30)	(1,0)	3.0	0.0	1.0	0.0	3.0	-3.0	6.6	3.0	10.0	n.s.
8	(0,20)	(-1,0)	(1,0)	3.0	1.0	0.0	0.0	4.3	-4.3	9.0	5.0	5.0	7
9	(1,16)	(-1,18)	(0,12)	2.0	0.0	0.0	1.5	7.5	-7.5	11.3	2.3	5.0	n.s.
10	(1,16)	(-1,18)	(0,12)	2.0	1.0	1.0	1.5	7.5	-7.5	11.3	2.3	5.0	8
11	(1,16)	(-1,18)	(0,12)	2.0	1.0	1.0	1.5	7.5	-7.5	11.3	2.3	10.0	n.s.

n.s. means 'not shown'

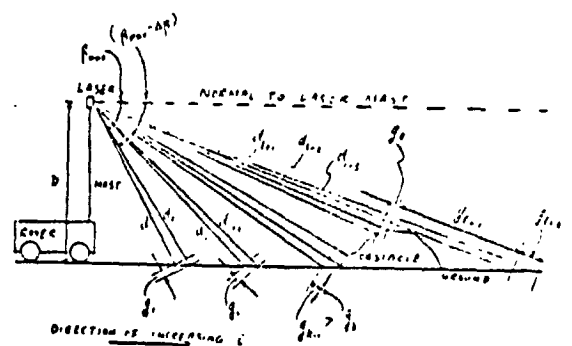

Figure 1 - Side View of Rover and Terrain

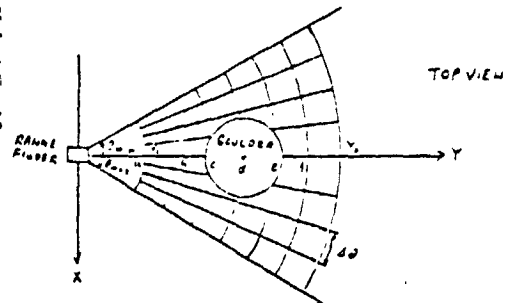

Figure 2 - Rangefinder Scanning Scheme

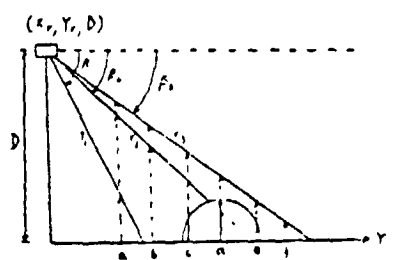

Figure 3 - Side View of the Plane with $\theta = 0^\circ$

RECOGNITION OF 3-D OBSTACLES
AND A SIMULATION

STUDENT: JIP LING LING
ADVISOR: DR. C. H. SUEN

THIS PROGRAM SIMULATES THE EDGE DETECTION SCHEME
USED BY THE RANGE FINDER OF THE MARS ROVER

A POINT, A HALF-SPHERE AND A CONE ARE USED AS OBSTACLES

OBSTACLE SPECIFICATION

1. LOCATION (IN 10 METERS)

ROVER IS AT (1.0 0.0 0.0)
POINT IS AT (1.0 1.0 0.0)
HEMISPHERE IS AT (1.0 0.0 10.0)
CONE IS AT (1.0 0.0 0.0)

Figure 4(a)
Parameter

2. SIZE IN METERS

HEIGHT OF THE CONE (RADIUS) IS 2.0
HEIGHT OF THE POINT IS 2.0
RADIUS OF THE HEMISPHERE IS 1.0
RADIUS OF THE CONE IS 0.0

SCANNING RANGE AND ANGLES

1. HORIZONTAL SCAN COVERS 10.0 DEGREE
ANG. FROM - 7.0 DEGREE TO 7.0 DEGREE

2. VERTICAL SCAN COVERS 0.0 TO 17.0 FROM THE CONE
ANG. FROM - 10.0 DEGREE TO 10.0 DEGREE

3. GAUSSIAN NOISE: MEAN VALUE 0.0 0.0
STANDARD DEVIATION 5.0 0.0

RESET TOPVIEW RANGE DATA EDGE DETECTION

0.00, 0.000
0.00000
0.00000
0.00000

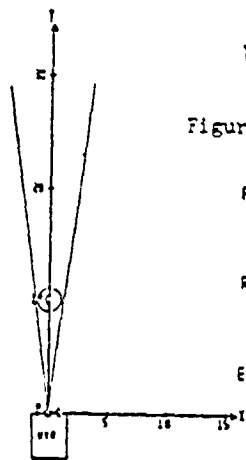

TOPVIEW

Figure 4(b)

PARAMETER

RNG. DATA

EDGE DET.

EDGE ENHANCEMENT BASED ON KIRKMAN FILTER & R.E.S.

COMPONENTS OF EDGE: 1. HORIZONTAL, 0. VERTICAL, 2. ANGLES, 3. 0 CROSS

Figure 4(c)

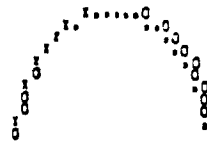

PARAMETER TOPVIEW RANGE DATA

Display for Case #2

EDGE ENHANCEMENT BASED ON KIRKMAN FILTER & R.E.S.

COMPONENTS OF EDGE: 1. HORIZONTAL, 0. VERTICAL, 2. ANGLES, 3. 0 CROSS

Figure 5
Display for
Case #3

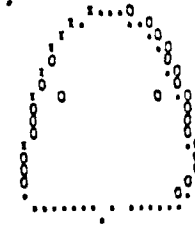

PARAMETER TOPVIEW RANGE DATA

EDGE ENHANCEMENT BASED ON KIRKMAN FILTER & R.E.S.

COMPONENTS OF EDGE: 1. HORIZONTAL, 0. VERTICAL, 2. ANGLES, 3. 0 CROSS

Figure 6
Display for
Case #6

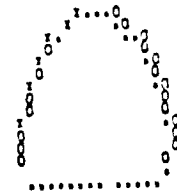

PARAMETER TOPVIEW RANGE DATA

EDGE ENHANCEMENT BASED ON KIRKMAN FILTER & R.E.S.

COMPONENTS OF EDGE: 1. HORIZONTAL, 0. VERTICAL, 2. ANGLES, 3. 0 CROSS

Figure 7
Display for
Case #8

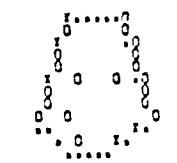

PARAMETER TOPVIEW RANGE DATA

EDGE ENHANCEMENT BASED ON KIRKMAN FILTER & R.E.S.

COMPONENTS OF EDGE: 1. HORIZONTAL, 0. VERTICAL, 2. ANGLES, 3. 0 CROSS

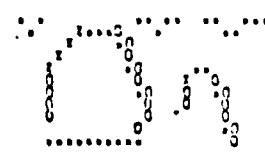

Figure 8
Display for
Case #10

PARAMETER TOPVIEW RANGE DATA