

DECOUPLING CONTROL TECHNOLOGY FOR MEDIUM STOL TRANSPORTS

Daniel K. Bird and Terry L. Neighbor  
 Air Force Flight Dynamics Laboratory

SUMMARY

This paper discusses the advanced control technology necessary to cope with the Medium STOL Transport landing problem and, in particular, the necessity to decouple with active control techniques. It will be shown that the need to decouple is independent of the powered-lift concept but that the provisioning for decoupling is most greatly dependent on the preassumed piloting technique. The implications of "decoupling" and "active control techniques" with respect to pilot technique options, handling quality criteria, flight control mechanization, and the use of piloted simulation as a design tool, will also be discussed.

INTRODUCTION

The Medium STOL Transport (MST) flight control system must play a major role in combining good up-and-away transport performance with good STOL capability. This STOL capability entails routine operation from a 2000 x 60 ft. strip. The use of powered-lift to provide the satisfactory low speed performance directly adds the need for active control technology while introducing many new unknowns, and aggravating the problem of engine failures. The basic foundation for this paper is derived from the results of recently completed AFFDL studies to develop the necessary MST technology. These studies involved three contractors, Boeing, General Dynamics and North American under AF Contracts F33615-71-C-1757, F33615-71-C-1754 and F33615-71-C-1760 respectively and included a collective total of approximately 500 hours of direct piloted simulation evaluations. (Refs. 1, 2, 3, 4, 5)

When attacking a problem area as large as the flight control system development for an MST, we quite often lose sight on the key points and tend to get bogged down in minor intricacies. It is easy to get involved in trivial arguments concerning the "hardware" in the kitchen before a suitable "foundation" for the house has been established. A stand-back-and-survey

view will therefore be presented with the hope that it will be enlightening. This stand-back position is the authors' main advantage. Because of our exposure to all three design efforts by the contractors, we saw certain patterns and restrictions occurring that have more meaning collectively than individually. A useful interpretation of these patterns and restrictions (real or self-imposed) is the main contribution we seek to present.

#### SYMBOLS

AFFDL	Air Force Flight Dynamics Laboratory
AFCS	Automatic Flight Control System
MST	Medium STOL Transport
STOL	Short Take-off and Landing
$C_{\ell}$	Rolling moment coefficient
$C_n$	Yaw moment coefficient
V	Velocity, knots
$n_z$	Normal acceleration, g's
$n_z/\alpha$	The steady-state normal acceleration change per unit change in angle of attack for an incremental elevator deflection at constant speed, g's/rad
$\alpha$	Angle of attack, degs
$\beta$	Sideslip angle at the center of gravity, degs
$\gamma$	Flight path angle = $\sin^{-1} \frac{\text{vertical speed}}{\text{true speed}}$ , positive for climb, degs
r	Yaw rate, deg/sec
$\theta$	Pitch angle, degs
$\psi$	Airplane heading, degs

#### MST FLIGHT CONTROL PROBLEM

##### Mission Origin

The Medium STOL Transport (MST) flight control problem has its origin in the mission goals. Briefly, these mission goals seek a capability of delivering a 28,000 pound payload into a short, narrow (2000' x 60') austere landing strip, in addition to having a cruise Mach number of 0.75, an operation radius

of 500 N.M. and a ferry range of 2600 N.M. The five fundamental phases of the flight control problem are:

1. Take-off
2. Cruise
3. Transition from Cruise to STOL configuration
4. STOL Approach
5. Transition from STOL Approach to Ground Roll

Of these phases, the "STOL Approach" receives the first, and justifiably, the most attention. This emphasis is due to the relative impact of this phase on the flight control system, both in defining requirements and limitations. While, in this paper, we will concentrate on the STOL Approach, the problems which arise from these other phases cannot be ignored.

It is appropriate to discuss the take-off briefly. There is a tendency to refer to "Take-off and Landing" as a joint lumping of a common problem area for flight control design. For the MST's, particularly, the take-off is a performance dominated ground-to-air problem whose influence on the flight control system is almost trivial compared to the air-to-ground landing problem.

#### STOL Approach Problem

The performance of a STOL landing on a 2000' x 60' runway necessitates low touchdown energy and reduced touchdown dispersions. To achieve these, a MST approaches at a low speed and steep flight path angle.

This low speed and steep approach angle leads to operation on the "backside" of the power-required curve and employment of active powered lift capability. The most prominent powered-lift systems under consideration are shown in Fig. 1. These powered-lift systems present coupling problems by their nature. The propulsive power that is now used directly to increase lift, also influences other force and moment generation. The "backside" area of the power curve effect is shown in Fig. 2. Note that for any velocity in this area, an increase in thrust setting at constant attitude results in an increased flight path angle with an accompanying decrease in airspeed. Similarly, if attitude is increased (with a fixed thrust setting) the aircraft responds to decrease velocity and increase rate of descent. This adverse coupling of attitude, airspeed and flight path, therefore, replaces the

favorable coupling associated with operation on the "frontside" of the power-required curve. The problems associated with a large angle between the flight path vector and the airplane body axis extend into the lateral-directional axes and further aggravate the normal coupling in these axes.

The large control surfaces required for low "q" operation add forces that are unfavorable in addition to the moments they are designed to produce. For example, a large elevator, in addition to producing a pitching moment, may produce a lift loss of significant magnitude.

A particular consequence of the low speed required is the increased sensitivity to atmospheric disturbances, i.e., wind shears, gusts, and turbulence, as they relate to both airborne controllability and landing precision. Internal disturbances such as engine failures and perhaps in combination with the "external" disturbances must be coped with.

Finally, in terms of conventional "flying quality" parameters, the dynamic characteristics of the "bare airframe" during landing approach can be generally characterized (Refs. 1, 2, 3, 4, 5) as having:

- (1) Strongly divergent spiral modes
- (2) Low Dutch Roll damping
- (3) Long roll mode time constants
- (4) Low  $n_z/\alpha$  sensitivity
- (5) Strongly coupled "short period" and "phugoid" modes

Item 5 stems directly from the attitude-speed-flight path coupling mentioned earlier and is worthy of special comment. The classical simplification to separately identify the "short period" mode as an oscillation of ( $\alpha$ ) at constant speed and the phugoid mode as an oscillation of (V) and ( $\gamma$ ) at constant angle of attack is not valid. (Ref. 6) "Short term" and "long-term" response are as important as ever but they cannot be satisfactorily developed within the context of the classical "short-period" and "phugoid" modes.

#### FLIGHT CONTROL SYSTEM DEVELOPMENT

The control of a "powered-lift" airplane for the short field capability desired for MST's must, therefore, take a far more basic approach to the flight control system development than would normally be required. The suggested plan of attack is indicated by an article which appeared in Aerospace

Engineering, September 1962, entitled, "Control Response Requirements", by Waldemer O. Breuhaus and William F. Milliken, Jr. The authors made the simple but significant point that all flight control can be broken down into three basic types: (1) Up-Down, (2) Right-Left, and (3) Fast-Slow. Although the article was written within the context of conventional controls, i.e., elevators, ailerons, rudders and throttles, the present day correlation with (1) Direct Lift, (2) Direct Side Force, and (3) Direct Drag, is obvious. The presentation that follows is designed to show that the "decoupling" philosophy referred to in 1962 as an interesting area to investigate has become a basic consideration in the design of flight control systems for the MST's.

A typical landing approach portion of the MST landing flight task is shown in Fig. 3. This part of the landing flight task will be emphasized because it received the most attention in the completed studies. It is hard to over-emphasize, however, that the transition from up-and-away flight to the desired landing approach speed-flight path profile and the transition from the landing approach to actual landing and deceleration to a stop, or a go-around, must receive careful attention in the final control system development.

#### Longitudinal Control

"The two principal quantities that need to be controlled in symmetric flight are the speed and the flight path angle, that is to say, the vehicle's velocity vector. To achieve this obviously entails the ability to apply control forces both parallel and perpendicular to the flight path." (Ref. 6) This enlargement of what longitudinal control really is, as compared to the too often made assumption that longitudinal control is limited to "elevator control", is one of the important messages of flight control development for the MST's. The second is the supposition that the pilot and/or autopilot must be able to make commands for speed changes without materially affecting flight path and conversely the ability to make flight path angle changes without materially affecting speed. Fig. 4 illustrates the design approach indicated for the longitudinal control provisions. There is no commitment at this point as to what input device will be used to command speed change or flight path change or what force or moment generators will be used for control. There is no direct control of  $(\theta)$  or consequently  $(\alpha)$ . The assumption is made that the airplane is "trimmed" for a given speed-flight path profile and that detection

of changes in this profile, ( $V$ ) speed and ( $\gamma$ ) flight-path, can be detected and acted upon by the pilot and/or autopilot. Fig. 4 serves as a common starting point to discuss the development of two MST longitudinal flight control systems by two separate contractors. One of the contractors featured an Externally Blown Flap (EBF) version for his study model and the other used a Mechanical Flaps plus Vectored Thrust version.

#### EBF Version

The key to the manner in which this would develop was this early statement, "In addition to the elevator, throttle and flaps are available for flight path control. The literature and experience indicates that the pilot would like to control flight path with the throttle on a power approach, where significant lift is due to the throttle. However, the coupling of airspeed and flight path through each of these controls makes bare airframe control deficient."

In effect, this philosophy indicates a strong preference to change the general form of Fig. 4 to assign a throttle level as the flight path command device. The same contractor goes on to say, "A direct lift system via throttle control gives the pilot two distinct means of controlling flight path:

1. Heave control with the throttle, with minor pitch changes.
2. Pitch control with the elevator, which depends on an adequate ( $n_z/\alpha$ ) to minimize ( $\alpha$ ) changes and make pitch changes result in flight path changes.

The equation ( $\gamma = \theta - \alpha$ ) expresses the two techniques, the heave control corresponding to changing ( $\gamma$ ) with ( $\alpha$ ) and pitch control changing ( $\gamma$ ) with ( $\theta$ ).\* The linear derivatives indicate the throttle to be a better direct

---

\*This statement is particularly interesting and significant for powered lift MST's. The general definition of ( $\alpha$ ) =  $\tan^{-1}w/u$  does not exclude this concept of ( $\gamma$ ) change with ( $\alpha$ ). It is a change in the conventional sense of ( $\alpha$ ), however, that must be carefully recognized in the application of many existing parameters.  $n_z/\alpha$  for example, is defined in MIL-F-83300 as "the steady state normal acceleration change per unit change in angle of attack for an incremental pitch control deflection at constant speed", and in MIL-F-8785 as "the steady-state normal acceleration change per unit change in angle of attack for an incremental elevator deflection at constant speed (air speed and Mach number)".

lift control and the flaps as better speed control as seen by:

$$\frac{Z_{\text{thrust}}}{X_{\text{thrust}}} = \frac{-0.1316}{+0.0351} = -3.75 \qquad \frac{Z_{\text{flaps}}}{X_{\text{flaps}}} = \frac{23.48}{14.89} = 1.575''$$

where

$$\frac{Z_{\text{thrust}}}{X_{\text{thrust}}} = \text{Ratio of change in vertical force (Z-axis) per change in horizontal force (X-axis) for a given change in engine thrust.}$$

and

$$\frac{Z_{\text{flaps}}}{X_{\text{flaps}}} = \text{Ratio of change in vertical force (Z-axis) per change in horizontal force (X-axis) for a given change in flaps deflections.}$$

As a result of this reasoning, the contractor used decoupling crossfeeds to the trailing edge flaps to minimize speed changes due to flight path commands through the throttle levers. He then constrained the control column to command elevator deflections only. Further refinements included an auto-speed mode which controlled to the selected speed directly by using the trailing edge flaps as the primary speed correcting output. An attitude-hold mode was also used to minimize attitude coupling from flight path commands through the throttle lever.

The functional operation of this type of system is generally illustrated in Fig. 5. In essence, they provided "direct lift control" as direct control of engine thrust magnitude and as commanded through the throttle levers as

---

Both of these definitions constrain the generality of  $(\alpha)$  for the purpose of applying the specification criterion  $n_z/\alpha$ . Further, the equation  $(\gamma = \theta - \alpha)$  is, in itself, a severe constraint on the vantage point that must be attained to fully cope with the MST landing problem.  $(\gamma)$  is defined in MIL-F-8785 as  $\sin^{-1}$  vertical speed/true airspeed. The distinction between this  $(\gamma)$ , defined with respect to the "air mass", and a  $(\gamma)$  defined with respect to the ground  $\tan^{-1}$  vertical speed/ground speed is too significant to ignore for the landing speeds and touchdown precision required for the MST's. Related criteria such as  $\partial\gamma/\partial V$  must also be carefully reviewed for application on MST's. The use of this criteria within the context of MIL-F-83300 and MIL-F-8785 is not only purposely limited to the "air mass" reference but also requires that it must be measured with constant thrust in both direction and magnitude and with a perturbation of the airplane solely by an "elevator" or equivalent  $(\theta)$  change producing device.

their main flight path control provision. They went on to conclude:

"In regard to piloting techniques for STOL terminal area flight operations, there is clearly a preference for the STOL mode of flight path control, i.e., power level adjustments for flight path error corrections with relatively constant pitch attitude maintained by a pitch-attitude-hold mode and airspeed regulated by the autospeed function."

#### Mechanical Flaps Plus Vectored Thrust Version

The key to this contractor's philosophy with respect to Fig. 4 is indicated by this statement:

"Pilots confirmed that they could use 'conventional' techniques for controlling flight-path angle and airspeed. The 'conventional' technique implies that flight path angle is controlled with the column and that thrust vector angle is used for controlling airspeed. The other control technique often used for STOL approaches involves controlling airspeed with the control column and flight path angle with thrust magnitude."

A control law structure that evolved from this concept is shown in Fig. 6. The use of this control during approach assumes that thrust vector trailing edge flaps, thrust level and spoiler deflection have all been set to satisfy "trim" for the desired flight path-speed profile. Flight path angle deviations are controlled through the control column which commands elevator and spoiler deflections about "trim" and speed deviations are controlled by closing an automatic speedloop which varied the thrust vector angle around the trim point, approximately  $70^\circ$  with the horizontal. A closed-loop decoupling crossfeed was found to be necessary for flight path angle-to-speed changes. The use of thrust vector angle changes to control speed reduced the speed-to-flight path (open loop) coupling to a point where cancelling by closed-loop decoupling was not considered necessary.

#### Summary of the Two Contractor Approaches

Each contractor recognizes the flight path angle-speed coupling problem. Each contractor made an, a priori, assumption as to what input device would be used to correct flight path deviations; in one case a throttle lever, and in the other, a control column and then suppressed the pilot effort associated



with speed corrections by using an automatic speed control loop. In the first case, the closure of the automatic speed loop was accomplished by deflecting the flaps about the trim position and thus vectoring the thrust indirectly with the flaps. In the second case, the efflux of the engine was vectored directly. Each arrived at a method of exerting forces for speed control, X-axis forces, that minimized the coupling of Z-axis (lift) forces.

Each used direct-lift to minimize speed changes caused by flight path change commands. In one case the "direct-lift" was in the form of thrust magnitude modulation about the trim position and in the other case symmetrical spoiler deflection about a trim position. Each was able to demonstrate within a reasonable degree of validation that the control of their respective study models, EBF and Mechanical Flaps Plus Vectored Thrust was generally satisfactory for an MST landing approach. Each contractor described his results as vindication of (1) the "STOL technique in one case and (2) the "Conventional" technique in the other. Substantiation arguments included the observation that when the "Conventional" technique was used with the "STOL" technique system designed for the EBF version, its performance was poorly rated by the simulation pilots. On the other side of the coin, it was pointed out that the "Conventional" technique was preferred for the Mechanical Flaps Plus Vectored Thrust version because:

- "(1) With the thrust vector set at approximately 70°, changes in vector angle primarily produce axial acceleration, with a small change in normal acceleration.
- (2) In the nominal approach condition and with the power set at 75% of maximum, the aerodynamics and propulsive normal acceleration capability is  $\Delta_{n_z}$  aero (with DLC) = .45g and  $\Delta_{n_z}$  thrust = .1g. With a single engine failure,  $\Delta_{n_z}$  thrust = 0 if the thrust to weight ratio is maintained."

The comments quoted in support of either the "Conventional" technique or the "STOL" technique are true statements. Their relevance to supporting either "technique" and to MST longitudinal control provisioning in general, however, needs examination.

#### "STOL" versus "Conventional" Technique?

Many papers have been written that discuss this choice. The overwhelming

majority of these papers make the often non-stated assumption that a control column or stick command is synonymous with elevator deflection and the throttle lever is synonymous with engine thrust modulation. Under this constraint, there isn't much left to close the coupled flight path angle-speed control loops, other than "pilot-technique". Augmentation and automation techniques that are restricted to operating through only the elevators or engine thrust commands will also be of dubious help because of the inherent coupling. For airplanes already built, the pilot-technique issue has validity because it is a case of doing the best you can with the only variable left to analyze, the pilot himself. For the "powered lift" MST's however, the so-called "STOL" versus "Conventional" landing technique issue, as it is normally presented, is of extremely doubtful validity.

The argument that the system designed for the "STOL" technique would not perform well when the "Conventional" technique was applied or vice versa, is not really a supporting argument. The pilot is no longer commanding an "elevator" or "throttle" or selecting a technique to use them; he, or the AFCS, is commanding flight path corrections or speed corrections through whatever input device was assigned. Any attempt to interchange the use of these assigned devices, which now command a set of force and moment generators through a control law structure deemed most suitable to make flight path or speed corrections separately, is obviously going to be difficult. The after-the-fact pilot option has been removed, the real issue is the basis on which the cockpit control assignment is made to best serve the MST mission.

#### Other Control Considerations

Fig. 4, as stated previously, makes the assumption that the airplane is in "trim" during landing approach. As a part of these same studies, at least one contractor found that the transition from up-and-away flight to the configuration required for landing approach, plus capture and "trim" to the required flight path-speed profile is difficult. It should be obvious that the assignment of cockpit controls cannot be made without careful consideration of how they can best serve these transition needs. Fig. 4 makes it clear that "attitude" during the landing approach is not necessarily the dominating control parameter. It is only important to restrain "attitude" changes within certain limits. When the transition is made from landing approach (airborne

flight) to touchdown (ground control) however, attitude must be reconciled along with a probable change in flight path from the "trimmed" condition.

The effects of engine failures and/or the need for a go-around must also be considered. The pilot must be given a control system that minimizes his workload in dealing with these emergencies. Finally, harmony with up-and-away flight where 95% of the mission time will be spent must be considered.

It is in this up-and-away flight regime where a more fundamental sense of what "Conventional" flight control really consists of can be more clearly illustrated. A recent paper (Ref. 7) states,

"The pilot must control the aircraft velocity vector in a three dimensional space. In a conventional airplane, the two vector angles ( $\gamma, \psi$ ) usually are tracked using column and wheel inputs, and the vector magnitude ( $V$ ) is controlled in essentially open loop or discontinuous fashion using throttle inputs".

The relegation of vector magnitude (Fast-Slow) control to an "essentially open-loop or discontinuous" manner is a key element of conventional flight control. For the MST's this type of control is no longer satisfactory during landing approach because of the severe coupling problem. Further, the control of speed, vector magnitude ( $V$ ), cannot necessarily be limited to thrust magnitude modulation, and finally, the manual closure of this control loop by the pilot, in addition to closing his ( $\gamma, \psi$ ) (Up-Down) (Right-Left) loops does not appear desirable from a pilot workload basis. The weight of the evidence indicates that ( $V$ ) must be controlled independent of the pilot, i.e., automatically. Still another factor is worth emphasizing in the selection of the longitudinal control provisioning for the MST's.

The landing of an MST and subsequent deceleration to a stop, or a go-around are obviously "energy-control" problems. (Ref. 8) The rate of energy consumed (fuel) as it affects the total airplane energy state, potential (height) plus kinetic (speed), is directly changed by the engine thrust lever. On the other hand, control forces used to change flight path generally only transfer potential energy (height) to kinetic (speed) or visa versa.

This energy concept does not lead to some easily perceived longitudinal control provisioning concept for the MST's. It is fundamentally significant, however, and far more relevant than trying to justify the system on a

preconceived "STOL" or "Conventional" technique basis. The merits of the longitudinal control provisioning must stand on its own feet.

#### Lateral-Directional Control

A vantage point for the lateral-directional control problems is illustrated by this quotation:

"This simplicity is lost (the author is referring to longitudinal control) when we go to lateral motions, for then the rotation takes place about two axes (x) and (z). The moments associated with these rotations are cross coupled, i.e., (p) produces yawing moments  $C_N$  as well as rolling moment  $C_l$ , and yaw displacements ( $\beta$ ) and rate (r) both produce rolling and yawing moments. Furthermore, the roll and yaw controls are also often cross-coupled, deflection of the ailerons can produce significant yawing moments, and deflection of the rudder can produce significant rolling moments."  
(Ref. 6)

In view of the previous discussion under longitudinal control, the reader is certainly entitled to question the "simplicity-comparison". The comparison is thought significant however. The need to provide "decoupling" in some degree has long been recognized for Right-Left control, while the need to do so for good (Up-Down) (Fast-Slow) is only fully appreciated when control must be provided near the minimum speed possible with "powered lift" techniques.

The treatment of lateral-directional control and its relationship to "decoupling" will therefore be less emphasized in this paper than longitudinal control, although this is not intended to suppress its importance. Landing on a 60 ft wide strip in the presence of "disturbances" is a demanding flight task.

None of the contractors involved in the studies investigated using direct side force for better Right-Left control although it has attractive possibilities. The decoupling approach, therefore, was immediately reduced from the generality presented in the longitudinal to that shown in Fig. 7, i.e., the control surfaces are conventional moment generators. The control law

development implied by Fig. 7 stems directly from the Etkins quote and the "decoupling" concept that the control wheel will command (p) without inducing ( $\beta$ ) and the rudder pedals will command ( $\beta$ ) without inducing (p).

Fig. 8 illustrates typical control laws that can develop from this premise. There can be no doubt that many of the symptoms of poor Right-Left control are removed by these active techniques. The initial development of undesired ( $\beta$ ) during entry into the turn can be largely cancelled out by feedforward into the rudder, and the remainder well suppressed by feedback techniques. "Feedforward is really a very old trick to cancel out the effects of disturbances before they have altered the output" (Ref. 9). In this case, the "disturbance" is an unwanted coupling of the outputs.

The Dutch Roll modes can be damped reasonably well and perhaps at least as important, the tendency to "stir-them-up" with roll rate commands can be largely removed. The spiral mode can be made essentially neutral such that the bank angle tends to neither increase nor bleed off during the turn. The effective roll time constant can be decreased such that the small precise heading changes associated with landing on a minimal width runway can be enhanced.

The decoupling techniques used for lateral-directional control are not as sensitive to the remainder of the total flight regime as the longitudinal provisioning. The transition from landing approach to ground-roll, however, has a similar problem in that "attitude" must be reconciled and particularly so when landing in a cross wind. If the crab angle is accepted during the landing approach (zero  $\beta$ ), then decoupling is desired to change the heading "attitude" of the airplane to that of the runway just prior to touchdown without changing flight path. The removal of yaw-to-roll coupling goes a long way towards achieving this type of flight path-to-attitude decoupling. If the forward-slip maneuver is executed, then the purposeful coupling must be "unwound" and the roll attitude of the airplane reconciled with the ground, again without materially affecting flight path.

There is one more aspect of "decoupling" that deserves mention, the coupling of lateral-directional or Right-Left control into (up-Down) (Fast-Slow) control. If heading changes are to be made without change of flight path or speed in the XZ-plane, then compensation must be provided for the loss of

lift due to bank angle. A relatively simple crossfeed of lift compensation per unit bank angle can be established if the previous "decoupling" of flight-path and speed has been accomplished.

#### IMPLICATIONS FOR DESIGN

The emphasis on decoupling just presented, is not an argument that complete "decoupling" must be provided for landing powered lift MST's. For many sound and substantial reasons, this is not likely to be either completely possible or desirable. This presentation is an argument, however, that the principles involved in decoupling must be thoroughly understood before the trades involved in backing-off can be justified. One of the most significant trades will be discussed briefly.

##### Flight Path-Speed-Attitude

The maturity of attitude sensors is well established whereas the ability to sense absolute flight path angle with respect to the ground involves finding the arctan vertical speed/ground speed. The latter quantity can be substantially different from airspeed and is not easy to obtain. A good attitude-hold loop, in itself, does a great deal to minimize the coupling between flight path and speed. On the other hand, the importance of controlling to an absolute ground referenced flight path for MST's can be appreciated by reading the article, "Effects of Wind Shear on Approach", by Captain W. W. Melvis, Delta Airlines, in the June, 1971 issue of Interceptor Magazine. The article discusses the problems of flight path and speed control in the context of 120 kt landing approach speeds. The increased concern at the MST landing approach speeds should be obvious.

##### Handling Qualities Criteria

There are many things that could be said about this controversial aspect of the MST's and as it relates to MIL-F-83300 and MIL-F-8785. A few of the observations considered most significant are listed here:

1. The concept of pilot workload as it relates to the MST landing task performance and as set forth in MIL-F-83300 and MIL-F-8785 is a sound and valid measure of "goodness" for MST "flying-qualities" or perhaps more aptly titled Flight Control Performance.

2. The interpretation of the pilot workload concept into

mutually verifiable, necessary and sufficient, contractor-customer "flying-quality" requirements is not presently satisfied by either MIL-F-8785 or MIL-F-83300. In general, MIL-F-8785 purposely excludes applicability to powered-lift, direct-lift, direct-drag and those active techniques directly associated with satisfactory MST landing capability, while MIL-F-83300 is too strongly oriented towards STOL as a transition to or from VTOL instead of an extrapolation from CTOL.

3. The main effect of this vacuum of applicability is to put a far higher premium on the use of piloted simulation as a "tool" for both contractor design development and customer assessment.

#### Piloted Simulation

It is difficult to make judgment as to which aspect of MST landing simulation was violated the most, the fidelity of the simulation required to be representative of what the pilot will actually experience, or the manner in which the simulation experiments were conducted. The representation of all forces acting on the airplane for the powered-lift MST's is, at least, an order of magnitude more complex than for a conventional airplane. Further, the quality of the vehicle dynamics data is susceptible to poor predictive techniques and the system design evaluations must recognize the need to consider variations from those assumed, even with extensive wind tunnel data.

The quality of the visual (outside world) presentation to the pilot has been troublesome. Unless the pilot is convinced that the representation is realistic, particularly in the landing touchdown transition area, the validity of the simulation data for design purposes is tenuous.

Motion can be required, particularly for investigation of engine failures, however, it is easy to overrate as a critical simulation parameter. Follow up experiments from fixed base to moving base during the MST studies revealed lateral acceleration as perhaps the most significant external force cue.

A large problem in accepting the piloting simulation data from these MST studies was the promiscuous use of Cooper Rating. The use of Cooper Rating as an after-the-fact evaluation is one thing. The use of Cooper Rating for design feedback without an active questioning of how and why the evaluations were given denies the needed use of piloted simulation as a design tool.

## Flight Control System Mechanization

The "hardware" implementation is necessarily discussed last because this choice must first of all be based on ability to satisfy the control-laws found necessary and as they encompass "decoupling" with active techniques. It is short-sighted to be in a hurry to discuss safety, reliability, and maintainability until the mechanized capability to perform the job can be established. The mechanizing job shares a common facet with other parts of MST development, i.e., the need to avoid premature commitments based on past mechanizing practices. A short saga of the MST mechanizing problem unfolds in the following manner.

Pure mechanical systems cannot provide sufficient performance. Pure Fly-by-Wire systems have sufficient performance but invite risks at this time that do not seem justifiable when compared to the performance attainable with a hybrid mechanical-electrical system. The number one issue, therefore, is how to design this hybrid mechanical-electrical system in a fashion that makes the best possible integrated use of these two types of signal transmission and which recognizes in particular the overriding electromechanical interface problem.

### CONCLUSIONS

1. The need for "decoupling" by active control techniques, i.e., separate non-interacting Up-Down, Right-Left, Fast-Slow control, is an essential part of MST flight control system design.
2. Cockpit controllers must be distinguished from the force and moment generators they control.
3. Piloted simulation must be used more extensively as a design tool.
4. Although the "landing approach" area is significant, the MST flight control system must fully recognize the total mission.



## REFERENCES

1. Vincent, James H., "STOL Tactical Aircraft Investigation - Flight Control Technology: Piloted Simulation of a Medium STOL Transport With Vectored Thrust/Mechanical Flaps", AFFDL-TR-73-19, Volume V, Part II, May 1973
2. Crandall, Kenneth J., Maund, David J., Gerken, William E., and Vincent, James H., "STOL Tactical Aircraft Investigation - Flight Control Technology: System Analysis and Trade Studies for a Medium STOL Transport with Vectored Thrust/Mechanical Flaps", AFFDL-TR-73-19, Volume V, Part I, May 1973
3. Hebert, J., Campbell, G., Price, E., et al, "STOL Tactical Aircraft Investigation: Flight Control Technology", AFFDL-TR-73-21, Volume V, May 1973
4. Elsanker, W. K., Okumoto, V. H., "STOL Tactical Aircraft Investigation - Externally Blown Flap-Flight Control Technology", Volume V, Part III, AFFDL-TR-73-20, April 1973
5. Campbell, J. E., Elsanner, W. K., and Okumoto, V. H., "STOL Tactical Aircraft Investigation - Externally Blown Flap - Flight Control Technology", Volume V, Part II, AFFDL-TR-73-20, April 1973
6. Etkin, Bernard, "Dynamics of Atmospheric Flight", John Wiley and Sons, Inc., 1972
7. Clymer, D. J., and Flora, C. C., "Approach Path Control for Powered-Lift STOL Aircraft", NASA CR-114574, April 1973
8. Jones, J. G., "Application of Energy Management Concepts to Flight-Path Control in Turbulence", Presented at the AGARD Flight Mechanics Symposium, Bedford, United Kingdom, May 1973
9. Peschon, John, "Disciplines and Techniques of Systems Control", pp. 82, Blaisdell Publishing Company, 1965

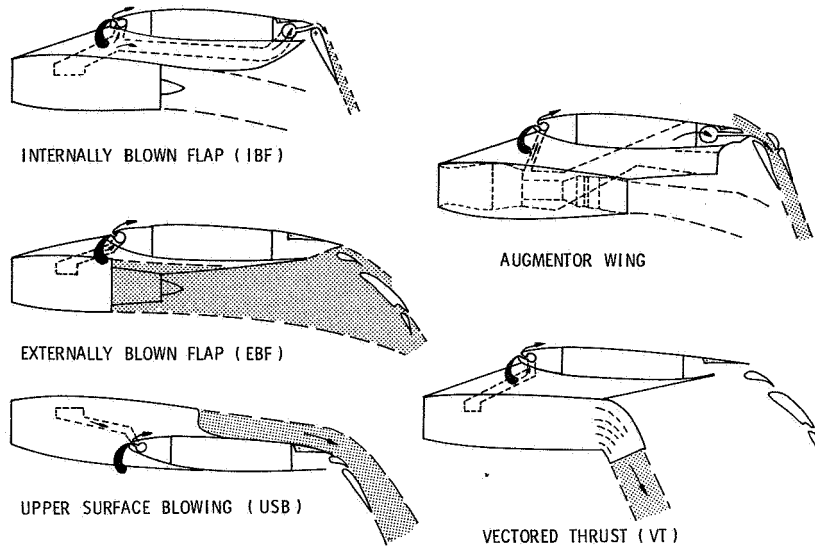

FIGURE 1. POWERED - LIFT STOL CONCEPTS

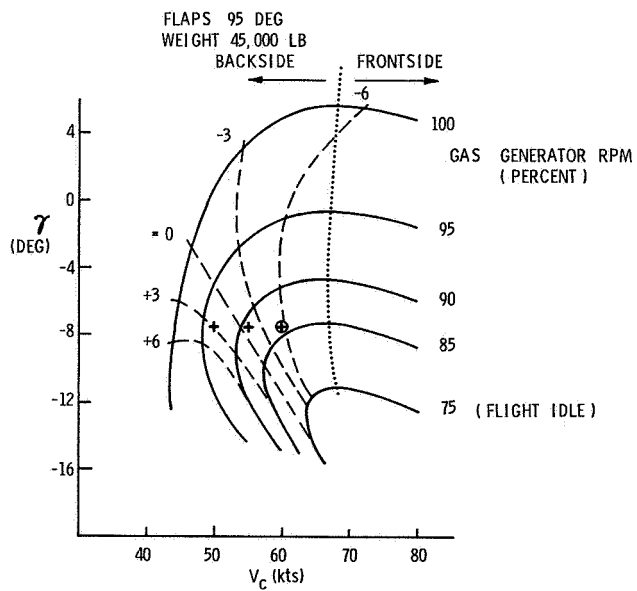

FIGURE 2. FLIGHT PATH VERSUS AIRSPEED FOR BREGUET 941

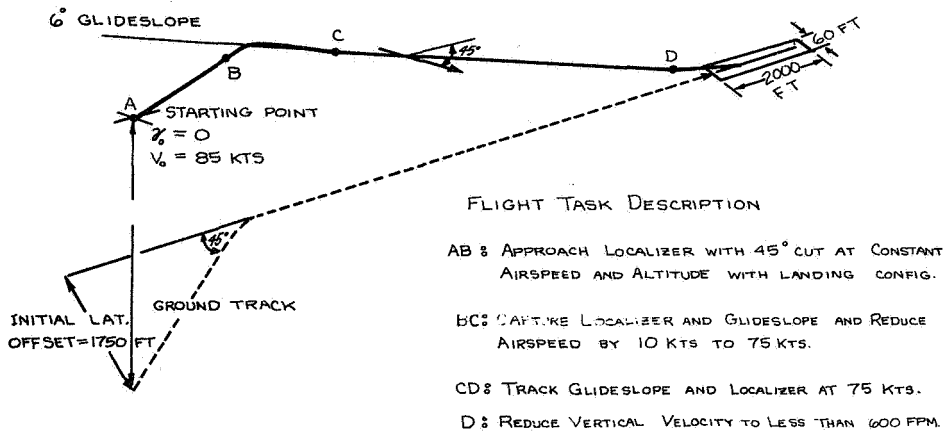

FIG. 3 TYPICAL LANDING APPROACH TASK

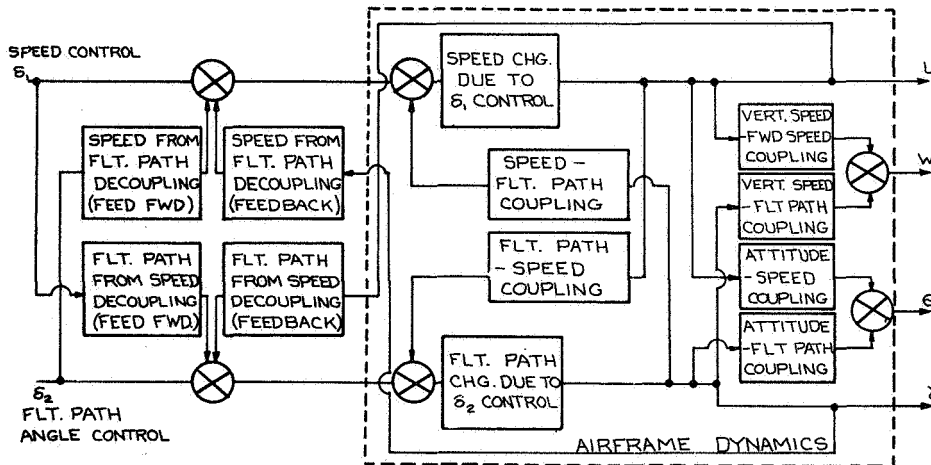

FIG. 4 DECOUPLED-LONGITUDINAL CONTROL

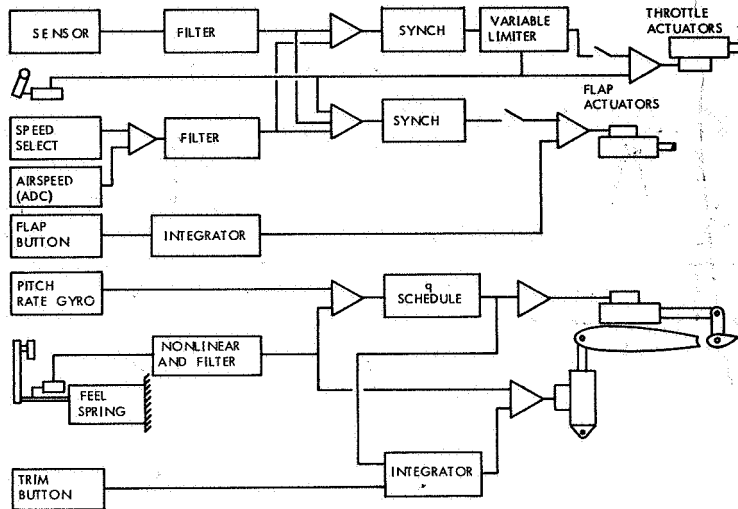

FIGURE 5 LONGITUDINAL CONTROL SYSTEM (EBF)

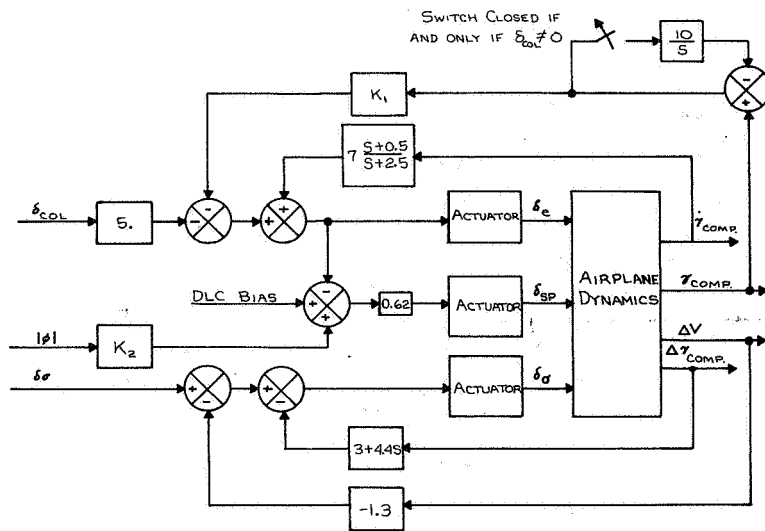

FIG. 6 LONGITUDINAL CONTROL SYSTEM (VT)

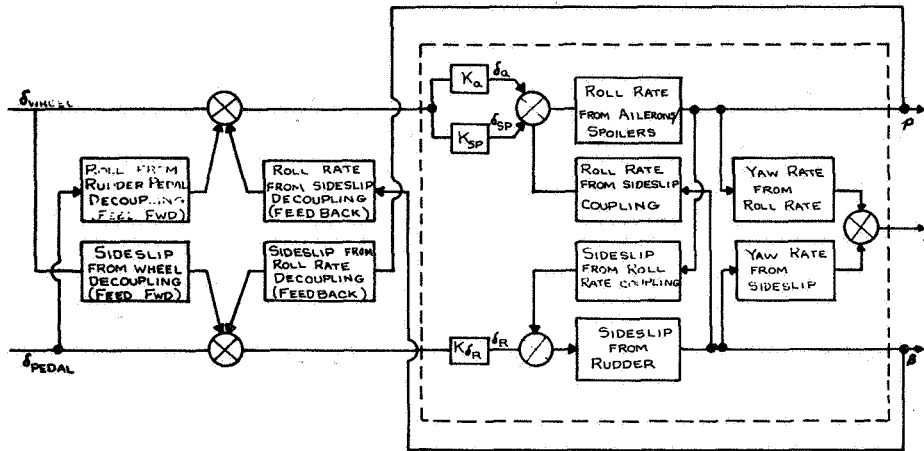

FIG. 7. DECOUPLED LATERAL-DIRECTIONAL CONTROL

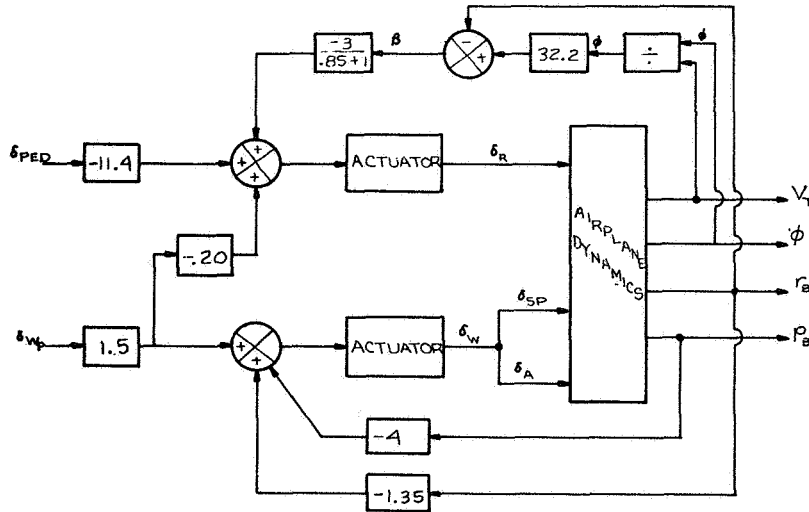

FIG. 8. LATERAL-DIRECTIONAL CONTROL SYSTEM (TYPICAL)