

**NASA CONTRACTOR  
REPORT**

**NASA CR-2700**



**NASA CR-2**

*C.1*



**LOAN COPY: RETURN TO  
AFWL TECHNICAL LIBRARY  
KIRTLAND AFB, N. M.**

**LH<sub>2</sub> AIRPORT REQUIREMENTS STUDY**

*G. D. Brewer, editor*

*Prepared by*  
**LOCKHEED-CALIFORNIA COMPANY**  
Burbank, Calif. 91520  
*for Langley Research Center*

**NATIONAL AERONAUTICS AND SPACE ADMINISTRATION • WASHINGTON, D. C. • OCTOBER 1976**





0061437

1. REPORT NO. NASA CR-2700		2. GOVERNMENT ACCESSION NO.		3. RECIPIENT'S CATALOG NO.	
4. TITLE AND SUBTITLE LH <sub>2</sub> AIRPORT REQUIREMENTS STUDY				5. REPORT DATE October 1976	
7. AUTHOR(S) G. D. Brewer - Editor				6. PERFORMING ORG CODE	
9. PERFORMING ORGANIZATION NAME AND ADDRESS LOCKHEED-CALIFORNIA COMPANY P.O. BOX 551 BURBANK, CALIFORNIA 91520				8. PERFORMING ORG REPORT NO. LR 27581	
12. SPONSORING AGENCY NAME AND ADDRESS National Aeronautics and Space Administration Langley Research Center Hampton, Virginia 23665				10. WORK UNIT NO.	
15. SUPPLEMENTARY NOTES Langley Technical Monitor: Peter F. Korycinski <u>Final Report</u>				11. CONTRACT OR GRANT NO. NAS 1-14137	
16. ABSTRACT This study was performed to provide a preliminary assessment of the facilities and equipment which will be required at a representative airport so liquid hydrogen (LH <sub>2</sub> ) can be used as fuel in long range transport aircraft in 1995-2000. Using San Francisco International airport as a basis for the analysis, a complete facility was conceptually designed, sized to meet the projected air traffic requirement. The facility includes the liquefaction plant, LH <sub>2</sub> storage capability, and LH <sub>2</sub> fuel handling system. In addition, the requirements for ground support and maintenance for the LH <sub>2</sub> fueled aircraft were analyzed. An estimate was made of capital and operating costs which might be expected for the facility. Finally, recommendations were made for design modifications to the reference aircraft, reflecting results of the analysis of airport fuel handling requirements, and for a program of additional technology development for air terminal-related items.				13. TYPE OF REPORT AND PERIOD COVERED Contractor Final Report; Sep 1975-Feb 1976	
17. KEY WORDS (SUGGESTED BY AUTHOR(S)) Hydrogen, airport fuel system, LH <sub>2</sub> liquefaction, LH <sub>2</sub> storage, air terminal operations, cryogenic, subsonic transport aircraft				14. SPONSORING AGENCY CODE	
18. DISTRIBUTION STATEMENT Unclassified - Unlimited  Subject Category 03					
19. SECURITY CLASSIF. (OF THIS REPORT) Unclassified		20. SECURITY CLASSIF. (OF THIS PAGE) Unclassified		21. NO. OF PAGES 199	22. PRICE* \$7.00



## FOREWORD

The Lockheed-California Company was the prime contractor to NASA and the study was accomplished within the Advanced Design Division of the Science and Technology organization, Burbank, California. G. Daniel Brewer was study manager and Robert E. Morris was project engineer.

Important segments of the work were subcontracted to the following organizations to provide the highest technical competence in all aspects of the study. The individuals named were principle contributors.

Ralph M. Parsons Co. (Airport and facilities planning)

Jack Hoyt  
Jon Batistic  
Richard Cline

Linde Division - Union Carbide Corporation  
(Hydrogen liquefaction and storage)

Richard Shaner  
Charles Baker  
Richard Carney

United Airlines (Aircraft maintenance and ground support)

Ralph Cramer  
Paul Campbell

All computations in this analysis were performed in U.S. Customary units and then converted to SI units.



## CONTENTS

Section	Page
FOREWORD .....	iii
LIST OF FIGURES .....	ix
LIST OF TABLES .....	xi
SUMMARY .....	1
1 INTRODUCTION .....	5
2 TECHNICAL APPROACH .....	6
3 PHASE I - DEFINITION OF THE AIRPORT LH <sub>2</sub> REQUIREMENTS .....	8
3.1 Task 1: Airport Selection .....	8
3.2 Task 2: Traffic and Fuel Requirements .....	10
3.2.1 Implementation Timetable .....	10
3.2.2 Projection of LH <sub>2</sub> requirement at SFO .....	19
3.2.3 Airport fueling facility design flow rate .....	29
3.2.4 Data summary .....	31
4 PHASE II - DESIGN AND EVALUATION OF SYSTEM ELEMENTS .....	31
4.1 Task 3: Hydrogen Supply Methods .....	31
4.1.1 Evaluation of distribution system losses .....	33
4.1.2 Hydrogen gas pipeline .....	34
4.1.3 Vacuum jacketed pipeline .....	34
4.1.4 Truck-trailer transport .....	39
4.1.5 Tank car transport .....	41
4.1.6 Comparison of transport methods .....	41
4.1.7 Economic analysis for present value .....	45
4.2 Task 4: Fueling Operations .....	48
4.2.1 Program and plans at SFO .....	49
4.2.2 Operational objectives .....	50
4.2.3 Hazard criteria .....	50
4.2.4 Candidate loading procedures .....	52

## CONTENTS (Continued)

Section	Page
4.2.5 Evaluation of external tank aircraft concept .....	60
4.2.6 System description .....	60
4.3 Task 5: Hydrogen Storage Evaluation .....	64
4.3.1 Tank farm requirements .....	64
4.3.2 Underground vs aboveground tanks .....	65
4.3.3 Vacuum insulated double wall tanks .....	66
4.3.4 Insulated single wall tanks .....	67
4.3.5 Economic comparison .....	68
4.4 Task 6: Hydrogen Liquefaction .....	69
4.4.1 Liquefaction facility requirements .....	73
4.4.2 Liquefaction facility description .....	73
4.4.3 Layout of liquefaction facility .....	80
4.4.4 Single module liquefaction layout .....	81
4.4.5 Safety considerations .....	81
4.4.6 Gaseous hydrogen vent collection system .....	81
4.4.7 Utilities .....	83
4.4.8 Costs .....	83
4.4.9 Personnel requirements .....	83
4.5 Task 7: Airport Fuel Distribution System .....	83
4.5.1 Fueling system description .....	89
4.5.2 Ground distribution and refueling system .....	92
4.5.3 LH <sub>2</sub> transfer method .....	95
4.5.4 Vent gas disposition .....	102
4.5.5 Defueling/refueling for aircraft maintenance ...	103
4.5.6 System reliability and availability .....	106
4.5.7 Instrumentation .....	107
4.5.8 System arrangement/installation concept .....	108
4.5.9 Hazards analysis .....	111
4.6 Task 8: Aircraft Maintenance Requirements .....	113
4.6.1 Changing of line replaceable units (LRUs).....	113
4.6.2 Inspection, maintenance and repair of tank and insulation systems .....	115
4.6.3 Handling of hydrogen aircraft in a maintenance hangar .....	116
4.6.4 Maintenance facility .....	116

## CONTENTS (Continued)

Section	Page
4.6.5	Line maintenance station at SFO ..... 118
4.6.6	Impact of hydrogen on normal routine maintenance of other aircraft systems and equipment ..... 118
4.7	Task 9: Airline Ground Support Requirements ..... 119
4.7.1	Facility and equipment requirements ..... 124
4.7.2	Special equipment required for LH <sub>2</sub> aircraft ... 126
4.7.3	Effect of aircraft configuration on maintenance and support requirements ..... 127
5	PHASE III - CONCEPT DESCRIPTION ..... 128
5.1	Task 10: Concept Arrangement and Description ..... 128
5.1.1	Description of selected concept ..... 128
5.1.2	Summary of cost implications ..... 137
5.1.3	Special facilities and equipment ..... 146
5.2	Task 11: Suggested Changes in LH <sub>2</sub> Aircraft ..... 152
6	RECOMMENDED RESEARCH AND TECHNOLOGY DEVELOPMENT ..... 154
7	CONCLUSIONS ..... 158
8	RECOMMENDATIONS ..... 161
	APPENDIX A - HYDROGEN SUPPLY METHODS ..... 163
	APPENDIX B - SAFETY CONSIDERATIONS ..... 179
	REFERENCES ..... 189





## LIST OF FIGURES

Figure No.		Page
1	Work Flow Chart .....	7
2	Typical LH <sub>2</sub> -Fueled Subsonic-Transport Aircraft .....	9
3	Three-View of Internal-Tank, 5500 n.mi. Subsonic Transport ...	11
4	Aerial Photo of San Francisco International Airport .....	15
5	Schedule for Operational Development of LH <sub>2</sub> Transport Aircraft .....	17
6	San Francisco Hub Airport Traffic Forecast .....	20
7	Ten Airports Projected for Initial LH <sub>2</sub> Facilities .....	23
8	Schedule for Construction of Airport Hydrogen Facilities .....	28
9	Total Quantity of LH <sub>2</sub> Loaded per Year at SFO .....	30
10	Total Cost of Gaseous Hydrogen Pipeline .....	38
11	Total Cost of Transporting Hydrogen Gas and Liquid vs Liquefier Distance from Airport .....	43
12	Cost for Liquid Hydrogen Transport Over 16.1 km (10 mile) Distance .....	44
13	San Francisco International Airport 1985 Plan .....	53
14	Comparison of Alternate Ground Handling Procedures .....	56
15	LH <sub>2</sub> Gate Requirements .....	57
16	Gate with LH <sub>2</sub> Service .....	61
17	LH <sub>2</sub> -Hydrant Fueling-Truck Concept .....	63
18	Cost of Spherical Double Wall Vacuum Perlite Insulated Liquid Hydrogen Storage Tanks .....	70
19	Cost of Three Types of Liquid Hydrogen Storage Tanks .....	72
20	Block Diagram - Liquefaction Process .....	74
21	Proposed Hydrogen Liquefaction/Storage Facility San Francisco International Airport .....	75
22	Plant Layout - 250 TPD Hydrogen Liquefaction Module .....	82

## LIST OF FIGURES (Continued)

Figure No.		Page
23	Typical Hydrant Pit .....	90
24	Hydrant Fueling Schematic .....	93
25	Distribution System Schematic .....	97
26	Distribution System Schematic .....	99
27	Distribution Loop Concept Plan .....	101
28	Typical Liquid Hydrogen Trench .....	110
29	Terminal Operations: Through-Stop 650 Nautical Mile Stage Length .....	121
30	Terminal Operations: Turnaround Station 5000 Nautical Mile Stage Length .....	122
31	Terminal Servicing Equipment for Current Jet A-Fueled Aircraft .....	123
32	LH <sub>2</sub> Facility Installation for SFO .....	131
33	LH <sub>2</sub> Distribution System and Gate Positions at SFO .....	133
34	Apron Taxilane Clearances (South) .....	135
35	Apron Taxilane Clearances (North) .....	136
36	Effect of Electric Power and Hydrogen Gas Feedstock Costs on Unit Cost of LH <sub>2</sub> .....	144
37	Aircraft LH <sub>2</sub> Fuel System Schematic .....	155

LIST OF TABLES

Table		Page
I	Preliminary Airport Screening .....	13
II	Final Airport Selection .....	14
III	Assumptions and Guidelines - LH <sub>2</sub> Aircraft Traffic Forecast .....	21
IV	Projection of Total Enplanements to 2000 A.D. ....	25
V	Projected Total Fuel Loaded - LH <sub>2</sub> -Aircraft at SFO .....	26
VI	Summary of LH <sub>2</sub> Loaded at SFO - 2000 A.D. ....	27
VII	Airline Destinations, Departure Times and LH <sub>2</sub> System Flow Rates .....	32
VIII	LH <sub>2</sub> Boiloff Losses and Production Requirements for Various Supply Methods .....	35
IX	Summary of Vehicle Operations .....	36
X	Total Cost (Present Value) of Gaseous Hydrogen Pipeline .....	37
XI	Total Cost (Present Value) of Transmitting Liquid Hydrogen via Vacuum Jacketed Pipeline .....	39
XII	Total Cost (Present Value) of Transporting Liquid Hydrogen via Truck-Trailer (Tank Method No. 1) .....	40
XIII	Total Cost (Present Value) of Transporting Liquid Hydrogen via Railroad Tank Car (Tank Method No. 1) .....	42
XIV	Assumptions for Economic Analysis .....	47
XV	Specifications: Liquid Hydrogen Storage Tank Vacuum Powder Insulation .....	66
XVI	Specifications: Liquid Hydrogen Storage Tank Multilayer Insulation .....	67
XVII	Specifications: Liquid Hydrogen Storage Tank Single Wall - Foam Insulation .....	68
XVIII	Economic Comparison Liquid Hydrogen Storage Tanks .....	71
XIX	Equipment List of Major Items: Hydrogen Liquefaction/ Storage Complex San Francisco International Airport .....	78
XX	Utility Summary: Hydrogen Liquefaction/Storage Complex, San Francisco International Airport .....	84

LIST OF TABLES (Continued)

Table	Page
XXI	Capital Investment: Hydrogen Liquefaction/Storage Complex, San Francisco International Airport ..... 86
XXII	Annual Operating Cost: Hydrogen Liquefaction/Storage Complex, San Francisco International Airport ..... 87
XXIII	Cost Assumptions: Hydrogen Liquefaction/Storage Complex, San Francisco International Airport ..... 88
XXIV	Summary of Investment and Operating Costs ..... 142
XXV	Base Cost of Liquid Hydrogen at SFO ..... 145

## LH<sub>2</sub> AIRPORT REQUIREMENTS STUDY

G. D. Brewer, Editor  
Lockheed-California Company  
Burbank, California

### SUMMARY

This is a preliminary assessment of the feasibility, practicability, and cost of providing facilities at a representative major U.S. air terminal to support the initial service of liquid hydrogen (LH<sub>2</sub>) -fueled long-range commercial aircraft in the 1990 decade.

The investigation is a logical outgrowth of concern over future availability and cost of petroleum - based Jet A fuel as petroleum reserves are depleted and as equitable worldwide distribution of the fuel becomes more uncertain. Several previous studies for NASA (Refs. 1, 2, 3, and 4) have shown the attractiveness of LH<sub>2</sub> as a fuel for both subsonic and supersonic transport aircraft. The present work is the first to address the question of what problems might be encountered in servicing LH<sub>2</sub> transport aircraft at an existing airport.

San Francisco International Airport (SFO) was selected to be the subject of the investigation because it represented a typical situation insofar as traffic mix, growth potential, and landside problems were concerned. It is emphasized that the plans developed herein involving use of LH<sub>2</sub> at SFO are entirely theoretical. They in no way reflect any known intentions of SFO management.

Consideration of possible schedules for implementing use of LH<sub>2</sub> as fuel for commercial transport aircraft led to a conclusion that operation from the initial city-pair of airports could feasibly occur in 1995. This was based on an assumption that a high priority national commitment to use LH<sub>2</sub> as fuel in transport aircraft would be made in 1980. Development of U.S. coal production capability to meet the requirements for manufacturing necessary quantities of gaseous hydrogen, in addition to the 50 percent increase in coal production already called for by the Federal Energy Administration, is the pacing item.

Expansion of the production capability of GH<sub>2</sub> could provide LH<sub>2</sub> airline service between SFO and the following 9 domestic and 4 overseas cities by 2000 A.D.:

<u>Domestic</u>		<u>Flights/day</u>	<u>Overseas</u>		<u>Flights/day</u>
Chicago	ORD	14	Tokyo	TYO	5
Honolulu	HNL	10	London	LHR	3
New York	JFK	9	Paris	CDG	2
Dallas - Ft. Worth	DFW	9	Rome	FCO	1
Atlanta	ATL	3			
Washington	IAD	3			
Miami	MIA	2			
Kansas City	MCI	2			
Los Angeles	LAX	7			

The number of flights per day from SFO listed in the table is postulated for an average day in the peak month in 2000 A.D. This maximum schedule requires 663,163 kg of LH<sub>2</sub> for block fuel use. Accounting for GH<sub>2</sub> boiloff which occurs in storage, refueling operations, and aircraft operations, an additional 15.7 percent of liquefaction capacity must be provided, making the total for the average day in the peak month 767,491 kg. Of this 15.7 percent boiloff, 91.5 percent can be recovered, piped back to the liquefaction plant, and both the gas and its refrigeration energy recovered. Most of the 1.35 percent of the total LH<sub>2</sub> produced which cannot be recovered is that portion which is vented in flight to avoid overpressurization of the aircraft tanks.

The preferred arrangement of LH<sub>2</sub> facilities for SFO places the hydrogen liquefaction plant and LH<sub>2</sub> storage tanks in a currently unused area on the south side of the seaplane harbor (see Figure 13). A small area of the basin would require landfill, and a causeway across the entrance to the basin would provide a convenient access route for the gaseous hydrogen (GH<sub>2</sub>) pipeline, electric power transmission line, and a road for operating and maintenance services. The facility is entirely within present boundaries of the airport.

Four 226,800 kg/day liquefaction plant modules are planned, providing an 18 percent excess for reserve capacity and growth potential. Based on liquefaction technology presumed for 1985 state of the art, 332 MW of electric power will be required. It is felt this requirement can be reduced when a more comprehensive systems analysis of the facility is performed.

Five spherical tanks, each 21.6 m in diameter, will provide storage of a total of 18 900 m<sup>3</sup> (5 x 10<sup>6</sup> gallons) of LH<sub>2</sub>. During operation, one tank would be pumped out of to supply LH<sub>2</sub> to the fueling circuit; one tank would be pumped into, both from the fueling circuit return and also from the liquefaction plant output; and the other three tanks are reserve. At least one peak-day reserve is available at all times in the event feedstock supply (gaseous hydrogen) is interrupted.

LH<sub>2</sub> is pumped from the storage tanks through vacuum jacketed pipes in two independent loops around the entire terminal area to provide an instantaneous supply at any of the 19 gate positions which are required to

meet projected long range traffic demands. The LH<sub>2</sub> supply lines, and a GH<sub>2</sub> boiloff recovery line, are located in a trench covered by an open steel grate for ready accessibility and to eliminate accumulation of hydrogen gas in the possible event of line leakage or rupture.

Analysis showed that LH<sub>2</sub> aircraft can be serviced at air terminal gates in essentially conventional fashion. Time required to refuel an LH<sub>2</sub> airplane, and to perform all other servicing functions for either a through-flight or a turnaround, can be the same as for an equivalent Jet A-fueled aircraft. The only differences are that for the LH<sub>2</sub>-fueled aircraft refueling is done at a single point in the tail cone of the fuselage instead of at separate connections under both wings; the flight crew must be provided a separate access to the flight station because the subject aircraft has no passageway between the passenger compartment and the cockpit; and, at least initially, until potential hazards are more realistically appraised, spark ignition vehicles may be excluded from an area 27.4 m in radius from the tail cone while fueling is in progress. In addition, a slight positive pressure may be required within the aircraft during fueling to prevent ingress of gaseous hydrogen in the event of a leak or spill of LH<sub>2</sub>. More detailed study of the safety aspects of the fueling procedures has been recommended to determine if these restrictions are necessary.

LH<sub>2</sub>-fueled aircraft will keep fuel in their tanks at all times, except when they are scheduled to be out of service for extended periods, e.g., more than 7 days, and when the tanks must be entered for inspection or maintenance. This minimizes thermal cycling of the tank structure and insulation system, and also eliminates undue delays and expense which would otherwise be involved in cooling down the tank/insulation system when the aircraft is prepared for its next flight. Since cold GH<sub>2</sub> which is boiled-off during out-of-service periods is recovered and reliquefied, the practice of keeping LH<sub>2</sub> in the tanks at all times is clearly cost effective.

It is anticipated that when LH<sub>2</sub> aircraft are initially placed in service, inspection of their fuel tanks will be required approximately once a year (after about 4000 hr of service). The procedures for defueling LH<sub>2</sub> aircraft to perform this inspection, and for the subsequent refueling, are quite time consuming and involved. Defueling consists of pumping out the fuel using the aircraft boost pumps, inerting, warmup, and flooding with air to permit entry. Refueling involves removal of the air, purification, and chilldown before the fuel can be pumped back in. The entire procedure is estimated to take from 6 to 18 hours depending on details of the situation. A special area for these defuel/refuel operations is provided adjacent to the liquefaction plant.



Estimated capital cost of the SFO LH<sub>2</sub> facility is summarized as follows:

	<u>\$10<sup>6</sup></u>
Liquefaction/storage plant	308.6
Distribution system	
● Trench construction	5.8
● Piping/valves, etc.	25.6
Hydrant fueler vehicles	<u>0.4</u>
Total	340.4

Annual operating cost for GH<sub>2</sub> feedstock and electric power amount to \$133.6 x 10<sup>6</sup>. Using baseline costs of 36.3¢/kg (16.5¢/lb) for GH<sub>2</sub> and 2¢/kWh for electricity, it is estimated the facility described herein can provide LH<sub>2</sub> fuel in the aircraft for 89¢/kg (40.3¢/lb = \$7.81/10<sup>6</sup> Btu).

## 1. INTRODUCTION

This study was a preliminary assessment of the impact the initiation of use of liquid hydrogen (LH<sub>2</sub>) as fuel for long range commercial transport aircraft will have on air terminal design, and on ground operations of the using airlines. The objective was to define the basic requirements for equipment, facilities, and operating procedures for a representative major air terminal at a time in the future when significant traffic could conceivably be converted to use of LH<sub>2</sub>. In addition, approximate costs for the LH<sub>2</sub> related equipment and facilities were to be established.

It was originally specified as a guideline that the study should be based on the premise that LH<sub>2</sub>-fueled long-range transport airplanes will be introduced into service in the 1990-1995 time period. On the basis of consideration of the long leadtime required to provide appropriate quantities of gaseous hydrogen from sources other than natural gas or petroleum, and assuming that a national commitment is made in 1980 that LH<sub>2</sub> will be used as fuel for future commercial transport aircraft, it was decided that initial operation could not realistically commence before 1995. The buildup of use in the succeeding five years would then permit 2000 A.D. to be used as a date for establishing representative requirements for fuel and traffic handling capability which could then serve as a basis for conceptual design of facilities and equipment.

San Francisco International Airport (SFO) was selected to be the subject of the analysis. It is emphasized that the changes and modifications for SFO postulated herein in no way reflect approved plans for the San Francisco facility. The cooperation of the airport management in providing drawings of facility arrangements planned for 1985 to provide a basis for the subject work is deeply appreciated. Changes to those plans which were made in the course of this study to investigate potential use of LH<sub>2</sub> at SFO are entirely hypothetical.

As a preliminary assessment, the study could not delve deeply into any particular aspect of the many problems which must ultimately be addressed in designing an LH<sub>2</sub> facility for an airport. The effort was directed to provide a realistic overall picture of the requirements for facilities, equipment, and procedures which use of LH<sub>2</sub> will impose on airports and airline operations. Inevitably, many interesting alternate approaches to some of the problems which were faced had to remain unexplored. However, the design of LH<sub>2</sub> facility which is described herein is considered to be feasible and practicable, and the costs are representative in today's dollars. Suggestions have been made for further studies and technology development which will supplement the present findings.

An outline of the approach which was taken in performing the study is presented in the following section.

## 2. TECHNICAL APPROACH

The technical approach used to accomplish the desired objectives is illustrated in Figure 1. The figure graphically illustrates the flow of the work described in detail in the report.

The scope of the work involved in formulating practical concepts of facilities, equipment, and procedures for operating hydrogen-fueled transport aircraft in the commercial environment in the 1990 decade required a diversity and depth of technical competence not available in any one company. Accordingly, Lockheed reached agreement with the following companies to participate in the study as team members on a subcontract basis in order to provide maximum competence and experience in critical areas. The experience of each company which was utilized in the subject study is indicated:

- Ralph M. Parsons Company, Pasadena, California -
  - Air Terminal and aircraft fueling facilities design and construction
  - Hydrogen distribution system design and construction
  - Overall airport system conceptual arrangement.
- Linde Division of Union Carbide Corporation, Tonawanda, New York -
  - Hydrogen manufacture, liquefaction, and storage
  - LH<sub>2</sub> supply methods.
- United Airlines, San Francisco, California -
  - Airline ground services and air terminal operations
  - Aircraft maintenance and repair procedures.

These capabilities, combined with Lockheed-California Company's knowledge of the design characteristics and support requirements of the subject hydrogen fueled aircraft provided the required basis for evaluation of the critical elements of this program and permitted formulation of viable concepts for air terminal facilities and operations.

As shown on the flow chart (Figure 1), the program was performed in three phases: Phase I, definition of airport LH<sub>2</sub> requirements; Phase II, design and evaluation of system elements; and Phase III, selection of a preferred arrangement of elements, and the complete air terminal complex for the selected airport formulated, described, and evaluated. This procedure of evaluating alternate arrangements of system elements and selecting preferred concepts for formulation of an air terminal complex provided the information necessary to meet the objectives of this study.

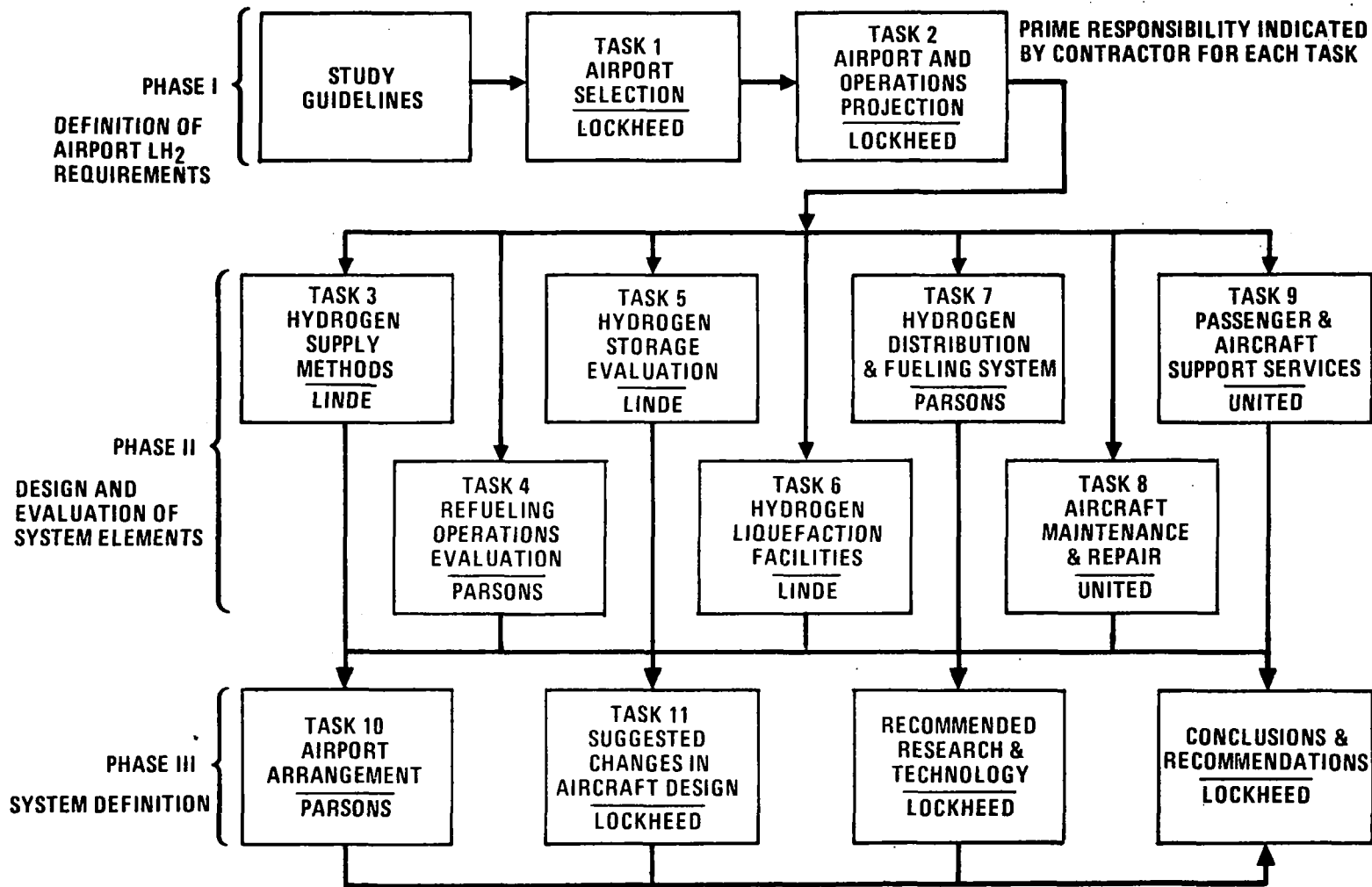

Figure 1. Work Flow Chart

The aircraft specified for the study were selected from Reference 2. They are shown in the artists concept drawing of Figure 2. These aircraft are both designed to carry 400 passengers 10 192 km (5500 n.mi.) at Mach 0.85. The essential difference in the aircraft is in the location of the fuel, one having external wing mounted tanks and the other internal (fuselage) tanks located forward and aft of the passenger compartment. A general arrangement of the internal tank aircraft is shown in Figure 3 to illustrate the location of the fuel tanks and the double deck passenger compartment typical of both aircraft. From both economic and performance considerations the internal tank is the preferred configuration, however the operational and servicing aspects of both aircraft were further evaluated in this study.

### 3. PHASE 1 - DEFINITION OF AIRPORT LH<sub>2</sub> REQUIREMENTS

The initial phase of the work established the basis on which assessment of the impact the use of LH<sub>2</sub> as a fuel in long-range transport aircraft would have on airport facilities and operations should be made. The first step was to select an airport which would be satisfactory for the purposes; the second was to define a traffic level and associated fuel requirements, which would serve as a model for designing the airport LH<sub>2</sub> fuel supply, and distribution system. These two steps were performed in Tasks 1 and 2, respectively.

#### 3.1 Task 1: Airport Selection

The first task was to select an airport to serve as a basis for study and evaluation of the services, materials, equipment, and land usage which would be required at a representative air terminal to implement the use of liquid hydrogen (LH<sub>2</sub>) in future commercial transport aircraft.

General criteria for establishing a viable list of candidate airports were the following:

- a. Must be a major airport with a representative mix of both long range and short range traffic forecast for the 1990 decade.
- b. The 1990 plan for the airport should allow consideration of any of several methods of performing LH<sub>2</sub> fueling operations in order to avoid artificial constraint of the study.
- c. All basic data about the airport's 1990 projections should be readily available to the contractor.
- d. The selected airport should be a representative example of the problems which will be encountered. The objectives of the study were best served by selecting neither the easiest nor the most difficult airport to convert to LH<sub>2</sub>.



Figure 2. Typical LH<sub>2</sub>-Fueled Subsonic-Transport Aircraft

Table I is a list of airports which were proposed and considered, and a brief summary of the conclusions reached as a result of the screening provided by the general criteria. Airports selected from the list for further consideration as a result of this preliminary examination were:

- San Francisco (SFO)
- Chicago O'Hare (ORD)
- Miami (MIA)

Final selection of the airport to be used as a basis for evaluation in the subject study resulted from the considerations summarized in Table II. It should be noted that all three of these airports were considered to be acceptable insofar as the purposes of the study are concerned. The evaluations of Table II are purely relative. The ratings were made in order to select one airport on which the study efforts could be focused. Accordingly, San Francisco (SFO) airport, shown in Figure 4 in a recent aerial photograph, was recommended by Lockheed as the airport to be used for the subject evaluations. The recommendation was approved by NASA.

### 3.2 Task 2: Traffic and Fuel Requirements

The objective of Task 2 was to determine the following information based on the utilization projected for the subject LH<sub>2</sub> fueled, wide-bodied aircraft at the specified airport in the designated time period.

- Flights per day
- Fuel requirements
  - Flow rate vs time of day for peak usage
  - Total quantity per day for peak month.

These data were then used in the remainder of the study as a basis for consideration in sizing the required airport facilities and planning the ground operations for the projected fleet of LH<sub>2</sub>-fueled, wide-bodied aircraft.

3.2.1 Implementation timetable. - Consideration of the following sequence of events served as a basis for defining the timing for initiation of use of LH<sub>2</sub> in long range, commercial transport aircraft. Note that the timing of the events is presented as feasible, not as a prediction of what might actually happen. The actual events which occur are dependent on major uncertainties such as:

- An authoritative decision being made to have the commercial air transport industry become an early, major user of hydrogen as fuel for new, advanced design aircraft.

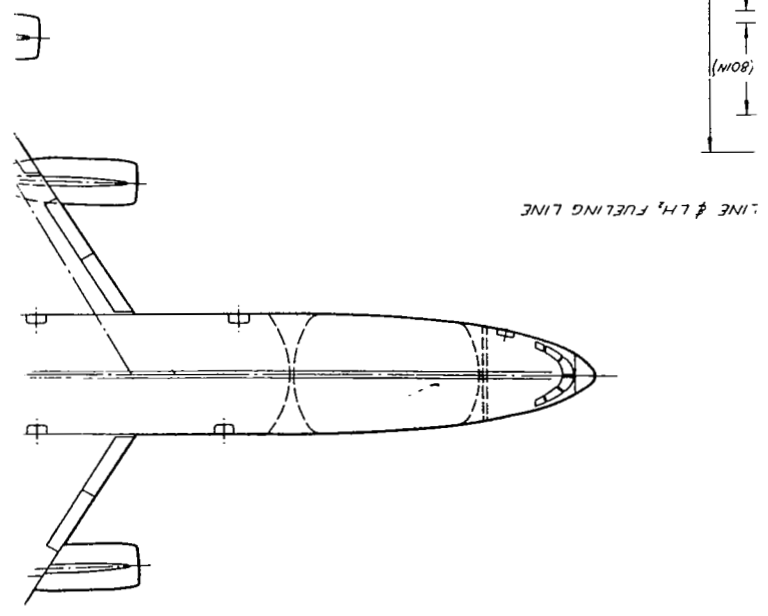
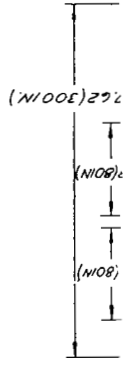
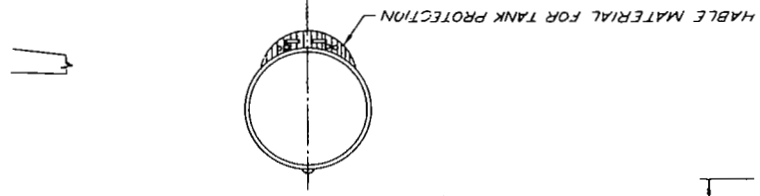
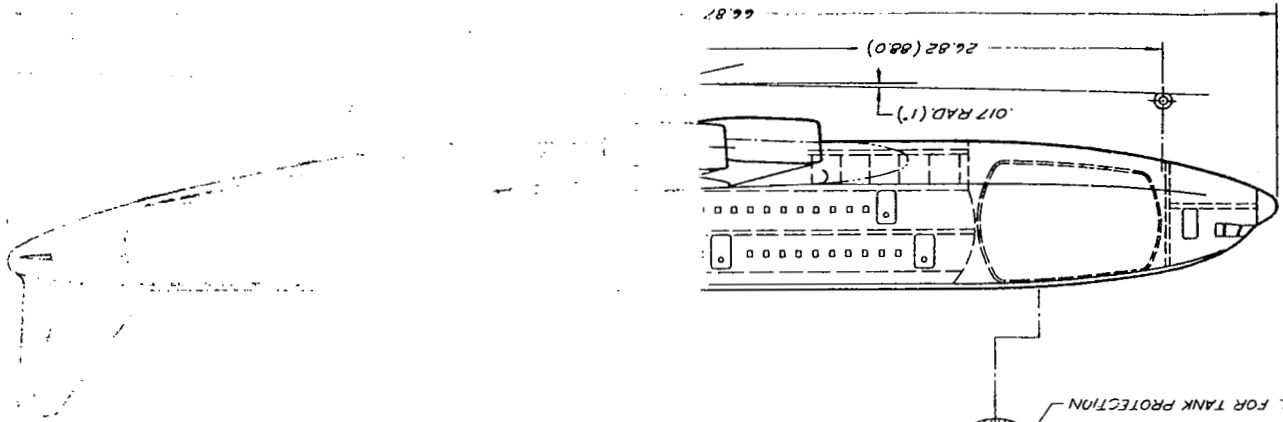



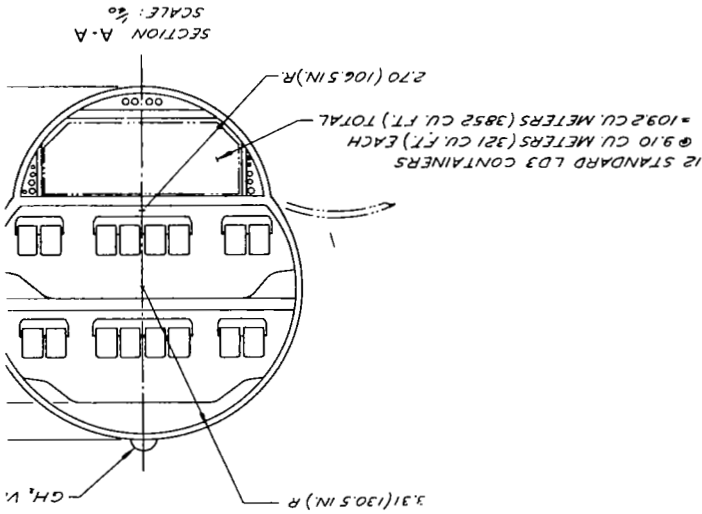
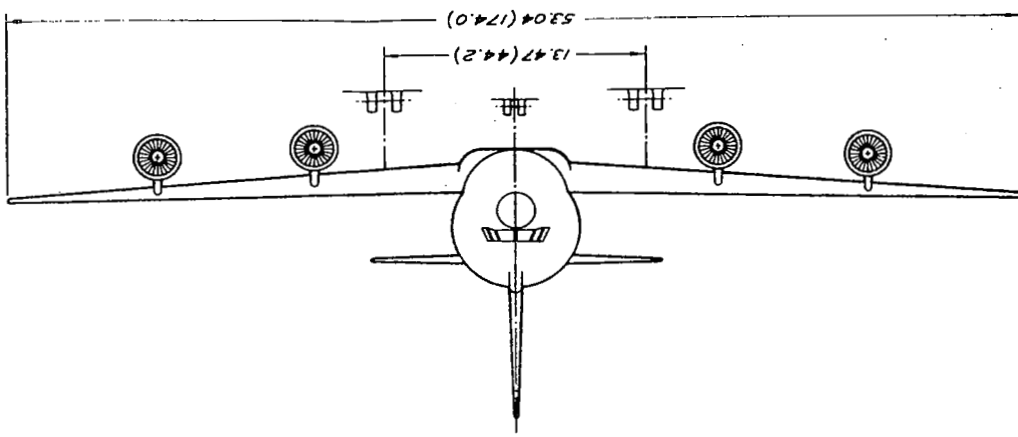

DESIGN GROSS WT. - 177,675 KG. (391,700 LB.)  
 POWER PLANT - (\*) TURBOFANS  
 INSTALLED THRUST (EA) - 127,660 N. (28,700 LB.)  
 PASSENGERS - 400  
 FUEL (LH) - 27,940 KG. (61,600 LB.)  
 RANGE - 10,192 KM. (5,500 N.M.)

CHARACTERISTICS	WING	HORIZ. TAIL	VERT. TAIL
AREA M <sup>2</sup> (SQ FT)	312.4 (336.3)	56.27 (610)	30.84 (332)
ASPECT RATIO	9.0	4.0	1.6
SPAN M (FT)	53.04 (174)	15.03 (49.5)	7.02 (23.04)
ROOT CHORD M (IN)	9.06 (356.9)	5.76 (226.8)	2.76 (266.0)
TIP CHORD M (IN)	2.72 (107.0)	1.73 (68.0)	2.03 (79.8)
TAPER RATIO	0.3	0.3	0.3
MAC M (IN)	6.46 (254.4)	4.10 (161.3)	4.83 (190.1)
SWEEP RAD (DEG)	0.524 (30)	0.524 (30)	0.524 (30)
T/C ROOT (%)	10	9	9
T/C TIP (%)	10	9	9

TABLE I. PRELIMINARY AIRPORT SCREENING

Candidate Airport	Passenger Handling Configuration*	Type of Traffic Forecast for 1990-95	Anticipated Difficulty of Providing LH <sub>2</sub> Facilities	Comments
Los Angeles (LAX)	Satellites/Linear	May be primarily short haul	Representative	Long haul future uncertain. New airport being planned.
San Francisco (SFO)	Satellite/Pier	Long and short haul, through and turnaround	Representative (fill may be required)	Selected
Honolulu (HNL)	Satellite/Pier	Primarily long haul	Representative (fill required)	GH <sub>2</sub> supply problem and traffic mix not representative
Dulles (IAD)	Transporters	Long and short haul, through and turnaround	Easiest	Not representative, too easy
Miami (MIA)	Pier	Lower fraction is long haul	Representative	Selected
New York (JFK)	Mix (most are pier or satellite)	Large fraction is long haul	Difficult	Not representative, too difficult because of space problem
Dulles/ Ft. Worth (DFW)	Linear	Long and short haul, through and turnaround	Easy	Not representative, too easy
Atlanta (ATL)	Pier	Large fraction is short to medium	Representative	Low fraction of long haul
Chicago (ORD)	Linear/Pier	Long and short haul, through and turnaround	Representative	Selected

\*Present arrangement. Future plans at each airport generally call for expansion along present lines; however, most could develop nearly any configuration required.

TABLE II. FINAL AIRPORT SELECTION.

Consideration	Airport		
	San Francisco (SFO)	Miami (MIA)	Chicago (ORD)
Space available for expansion	OK	OK	Poorest
Traffic mix forecast for 1990-95	OK	Poorest	Best
Availability of airport data to contractor	Best	Poorest	OK
Selection (in order of preference)	1	3	2

NOTE: All three airports are acceptable for purposes of the study. Ratings were assigned to select one airport for analysis.

- The timing and priority assigned to this decision.
- The efficacy with which a plan is implemented to mine the coal and to create plants to manufacture hydrogen in sufficient quantities, and for designated airports to be equipped with necessary liquefaction, storage, and handling facilities.
- Coordination of U.S. emphasis on aircraft usage of LH<sub>2</sub> with governments of other countries which are major participants in international air travel.

However, considering the serious nature of the problems associated with assuring an adequate worldwide supply of petroleum fuel for commercial transport aircraft at an economically acceptable price, and the many attractive advantages which can be realized from switching advanced designs of such aircraft to LH<sub>2</sub>, it is felt that the possibility of necessary positive action being taken is high and that the suggested timetable for implementing this change is feasible.

It should be recognized, and is hereby emphasized, that development of a rigorous analysis of all the interrelationships involved in this general subject of changing fuel systems for the air transport industry is a subject deserving of very serious attention. A comprehensive societal impact study should be made to explore properly the ramifications such a change would make in established economic, industrial, commercial, regulatory, and social processes.

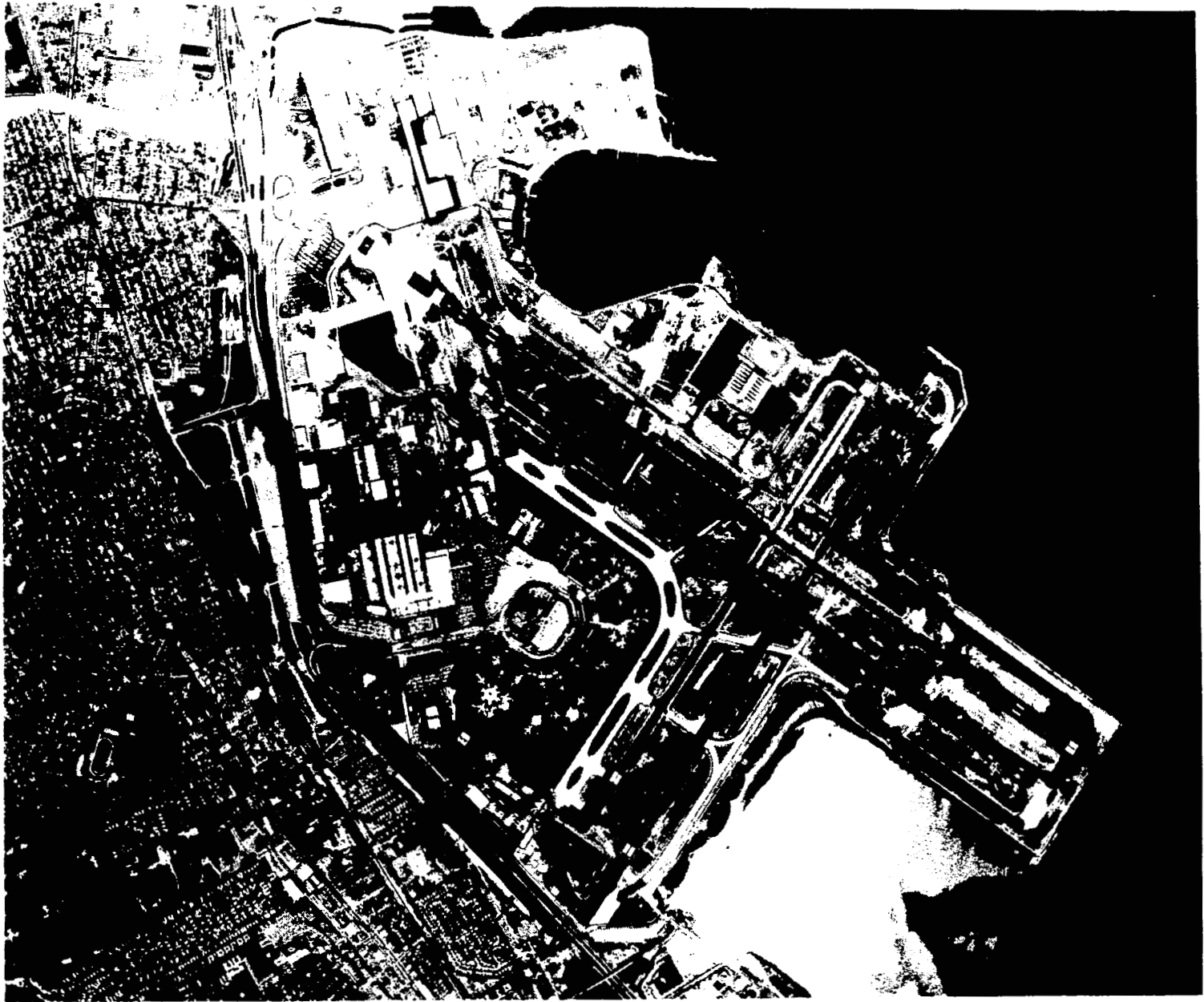

Figure 4. Aerial Photo of San Francisco International Airport

Figure 5 presents a feasible timetable for elements of the series of actions which must occur in order that significant numbers of long-range, LH<sub>2</sub>-fueled transport aircraft can operate from San Francisco International Airport (SFO) by the year 2000. The development activity shown in the figure is divided into five major categories. Each of these elements must be addressed and successfully accomplished in order for the end objective to be achieved.

#### Item No. 1: Hydrogen Technology Development

This item is a program of development of hydrogen technology for aircraft application. It is described in Section 6 of NASA CR-132559 (Ref. 2). As indicated in Figure 5, a program of technology development has already been initiated by NASA and should be actively pursued in order to provide the special knowledge of hydrogen-peculiar equipment and systems needed to complete design and development of the first production aircraft, Item 2, in timely fashion.

#### Item No. 2: Aircraft Development

The scheduling of Item No. 2 is consistent with current practice in the industry for development of large aircraft incorporating advanced design features. After completion of development of critical hydrogen technology and after a series of design studies to select a preferred basic concept, two years is permitted to establish detail design of the production aircraft. After design freeze, and while final design details are completed, fabrication of long lead time items is begun. Fabrication of the first aircraft can be completed in just over three years, six years after selection of a preferred design concept. First flight of this aircraft could occur approximately one year later after a program of extensive ground testing.

Delivery of the first aircraft for operational airline service would normally follow about three years later, putting initial commercial operation of a hydrogen-fueled transport aircraft in 1995. Normal build-up of production deliveries would result in 22 aircraft being put in service the first year, 48 the second year, and 220 within five years.

The buildup of production of LH<sub>2</sub>-fueled aircraft can be much faster than deliveries can be assimilated in commercial operations. Development of gaseous hydrogen production capability, Item 4, and airport facilities, Item 5, will pace the growth of LH<sub>2</sub>-transport aircraft usage. Nevertheless, aircraft development must be started in about 1985 in order that aircraft can be delivered for initial operation in 1995.

#### Item No. 3: Engine Development

Engine development would proceed in parallel with the aircraft development so delivery of the first set of engines for installation on the prototype aircraft could occur approximately one year before first flight.

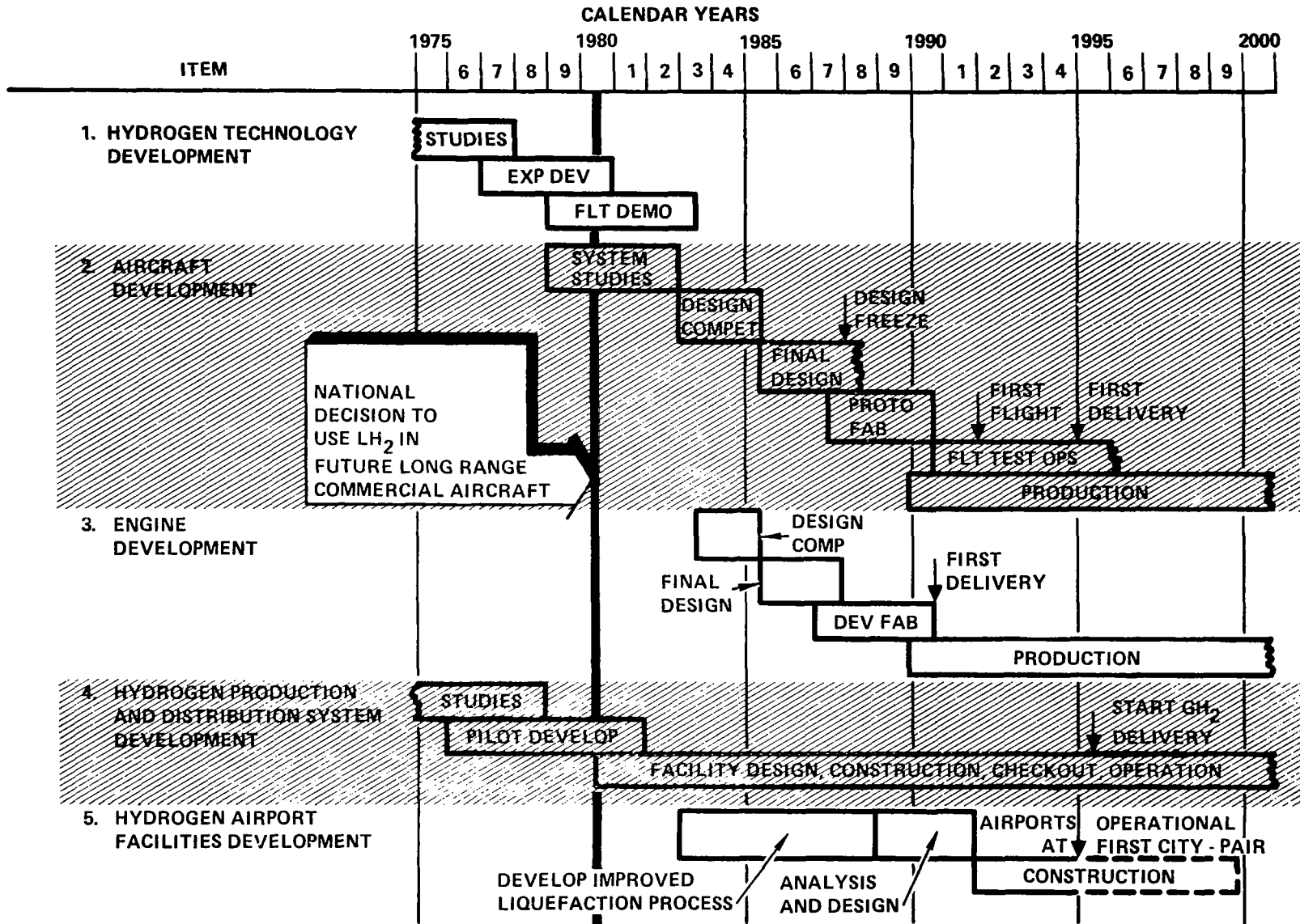

Figure 5. Schedule for Operational Development of LH<sub>2</sub> Transport Aircraft

#### Item No. 4: Hydrogen Production and Distribution System Development

Development of a capability for production and distribution of adequate quantities of gaseous hydrogen (GH<sub>2</sub>), will require immediate priority attention. This is the critical pacing item of the entire undertaking.

The quantities of GH<sub>2</sub> required to support airline usage of long-range, wide-bodied aircraft in the time period starting in the 1990 decade will require dependence on the production processes which are currently understood and basically developed, aside from steam reforming of natural gas or partial oxidation of crude oil, for which neither resource can logically be considered to be available for the present purpose. These production processes are gasification of coal and/or organic wastes, and electrolysis of water, using nuclear fission reactors to generate the electricity.

Both processes would require long lead times for development of a capability for supplying adequate quantities of GH<sub>2</sub>. The time required to expand our coal mining capability significantly is estimated at about 10 years. The lead time for building new nuclear reactors is currently about twelve years.

Clearly, it will take a high order of national incentive, similar to that demonstrated in the Manhattan Project and in the U.S. Apollo "Man on the Moon in this Decade" program, to accomplish the tasks required to have adequate GH<sub>2</sub> production and transmission capability available in time to supply the needs of commercial transport aircraft starting early in the 1990 decade, assuming go-ahead for a program to convert U.S. commercial aircraft to LH<sub>2</sub> fuel is given in 1980 (see Figure 5).

Initial use of LH<sub>2</sub>-fueled aircraft can occur when at least two airports which constitute a city-pair involving significant reciprocal traffic are equipped with LH<sub>2</sub> refueling and maintenance capability. Realistically, it is considered that 1995 would be a credible date to indicate initial capability for supplying gaseous hydrogen in substantial quantities for liquefaction at two airports. This date is reflected in the timetable shown in Figure 5.

#### Item No. 5: Hydrogen Airport Facilities Development

The objective of this study was to provide an assessment of the problems and requirements of handling LH<sub>2</sub>-fueled transport aircraft at a designated airport. It would serve no useful purpose if the study was conducted for an early time period during which only a few LH<sub>2</sub>-fueled aircraft could be serviced because availability of hydrogen limited the number of airports to and from which the LH<sub>2</sub> aircraft could fly. The purpose of Task 2 was to make an evaluation of the supply potential and the demand requirements for LH<sub>2</sub> in order to select a time period which offered a credible basis for studying the operational problems of LH<sub>2</sub>-fueled aircraft.

A comprehensive study of this subject would include a detailed evaluation of a potential schedule for providing an adequate supply of gaseous hydrogen to all the airports involved in initiating use of LH<sub>2</sub> as fuel for commercial transport aircraft. The present study is limited to consideration of the airport facilities required at SFO for liquefaction, storage, and transfer of the hydrogen. Judgments concerning initial availability of GH<sub>2</sub> for delivery to airport sites across the country must therefore be limited to the considerations expressed under Item 4, above. It may be added, however, that although 15 years is probably a reasonable estimate for initial GH<sub>2</sub> delivery capability, succeeding airports could be expected to be provided with the required gaseous hydrogen at an increasing rate, paced primarily by funding limitations and start dates. It would be expected that the capability for mining coal would be developed, and/or that nuclear plant design would be standardized and that substantial savings in both cost and construction time could be effected after the initial efforts.

Design and construction of hydrogen liquefaction plants is much more mundane than developing major new coal mines and building coal gasification plants, or equivalently, building nuclear reactors. For example, it is estimated that it will require about 42 months for design and construction of the first 226 800 kg/day (250 ton/day) hydrogen liquefaction plant. Succeeding plants can be expected to be built in 36 months. Accordingly, it is felt that development of hydrogen liquefaction, storage, and handling facilities at airports around the country, with proper lead time and planning, can proceed on a schedule which matches the projected availability of the GH<sub>2</sub>.

3.2.2 Projection of LH<sub>2</sub> requirement at SFO. - With this projection of a feasible schedule for availability of facilities to manufacture and use LH<sub>2</sub>, the problem then was to determine the quantity of LH<sub>2</sub> fuel required at San Francisco airport as a function of time, starting in 1995, and as a function of the airports which could be added to the list as they might be equipped properly to service the subject long-range, LH<sub>2</sub>-fueled transport aircraft. As more city pairs are added to the list, more LH<sub>2</sub>-fueled aircraft must be handled at SFO and the assessment of the facility, equipment, and handling problems becomes more meaningful.

The ATA Airport Demand Forecast (Ref. 5), was used to establish an estimate of the current and future traffic involving long range, large aircraft operating into and out of SFO. Figure 6 is a plot of passenger enplanements forecast as a function of years for the San Francisco Hub, which includes SFO, the Oakland airport (OAK), and San Jose airport (SJC). Interstate, international, and intrastate flights are all shown to indicate the total activity of all the scheduled carriers in that hub region. According to the reference, and as shown in the figure, the number of enplanements projected for SFO in years subsequent to 1990 is not expected to increase substantially because of saturation of SFO runway capability.

Assumptions and guidelines for the study to determine the traffic and fuel flow requirements for the San Francisco airport in the 1995 - 2000 time period are listed in Table III. A list of ten domestic airports, including



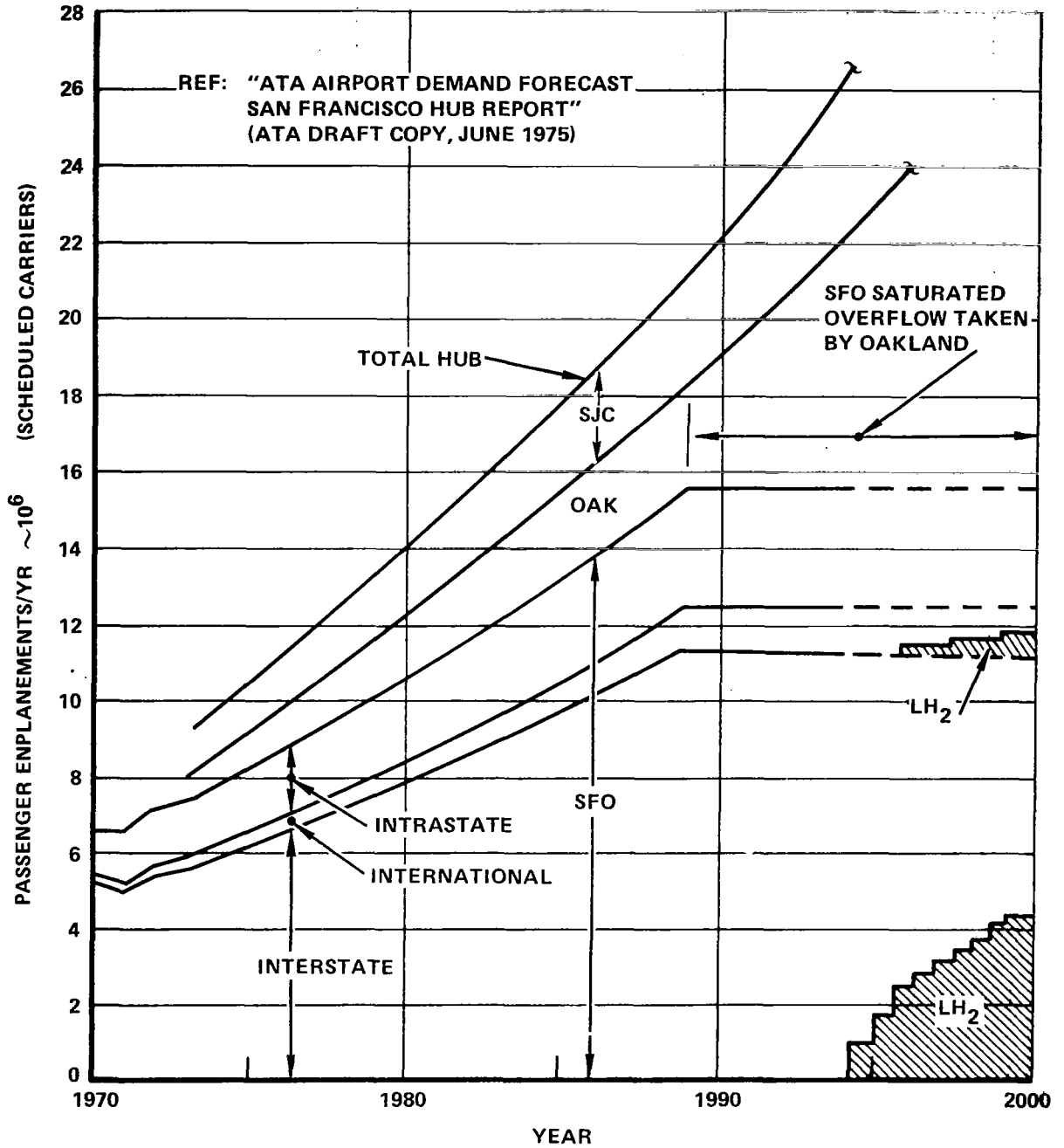

Figure 6. San Francisco Hub Airport Traffic Forecast

TABLE III. ASSUMPTIONS AND GUIDELINES - LH<sub>2</sub>  
AIRCRAFT TRAFFIC FORECAST

1. Basis of traffic forecast is "ATA Airport Demand Forecast - San Francisco Hub Report" by Air Transport Association of America, Draft Copy dated June 1975 (Ref. 5). No intrastate traffic will be considered.
2. By 2000 A.D. the following major terminals will have LH<sub>2</sub> liquefaction and LH<sub>2</sub> aircraft handling facilities:
  - a. Domestic
 

1. SFO - San Francisco	6. ATL - Atlanta
2. ORD - Chicago	7. LAD - Dulles
3. HNL - Honolulu	8. MIA - Miami
4. JFK - New York	9. MCI - Kansas City
5. DFW - Dallas, Ft. Worth	10. LOS - Los Angeles
  - b. Foreign
 

TYO - Tokyo	CDG - Paris
LHR - London (Heathrow)	FCO - Rome
3. Flights from SFO to the cities in 2, above, will be assumed to have the same distribution as shown in the August 1973 Official Airline Guide (Ref. 6).
4. LH<sub>2</sub> aircraft will be used only on direct, non-stop flights from SFO to the cities in 2, above, except they will also be used on through-flights via LOS to the cities in 2a.
5. The only airplane(s) used will be the LH<sub>2</sub>-400 pax, 10 192 km (5500 n.mi.) range versions defined in NASA CR-132559 (Ref. 2).
6. No direct non-stop flights from SFO to Europe are made at present; however, by 2000 A.D. it is anticipated that the demand will support a reasonable number of such flights. This demand will be estimated.

SFO, which were selected as being logical candidates for early installation of hydrogen fuel and related facilities is shown as item 2 in the table. Location of these cities on the map of Figure 7 shows that they provide good geographical coverage of the more populated areas of the United States.

The four foreign airports listed were also assumed to have LH<sub>2</sub> fueling capability to provide for projected international flights from SFO. As noted, the Airline Guide (Ref. 6) provided data on traffic in mid-August, 1973, between SFO and each of the domestic airports listed, including flights to Tokyo. Traffic to the other foreign airports listed was assumed as described subsequently.

The following procedure was used to arrive at projections of passenger and LH<sub>2</sub> fueled aircraft traffic, plus estimates of fuel flow requirements, at SFO for the 1995 - 2000 time period.

LH<sub>2</sub> Demand Estimation Procedure (1995 - 2000) Interstate:

- a. Using the Official Airline Guide for the peak month (August) in 1973 the number of nonstop flights, departure times, and equipment used were obtained for the candidate city-pairs.
- b. The seating capacity of each aircraft, multiplied by the 1973 interstate payload factor (0.54) from Ref. 5, times the flight frequency (above) gave the number of passenger enplanements in August 1973.
- c. The ratio of number of August flights to the monthly average was found from Ref. 5. With this ratio, the total number of enplanements per year to each city-pair was calculated for 1973.
- d. From Ref. 5, the growth of interstate traffic from 1973 to 2000 was found to be a factor of 1.97<sup>4</sup> (5.67 to 11.19 x 10<sup>6</sup> enplanements). Using this growth factor, the 2000 A.D. enplanements was found for each city, assuming the distribution by city remained the same as 1973.
- e. Using the 2000 A.D. average payload factor for interstate traffic (0.64) from Ref. 5, the number of flights to each city was calculated.
- f. Block fuel was determined based on the equivalent still-air flight distances to each city. Block fuel times the flight frequency, plus boil-off and miscellaneous losses, gave the total yearly fuel consumption to each city.

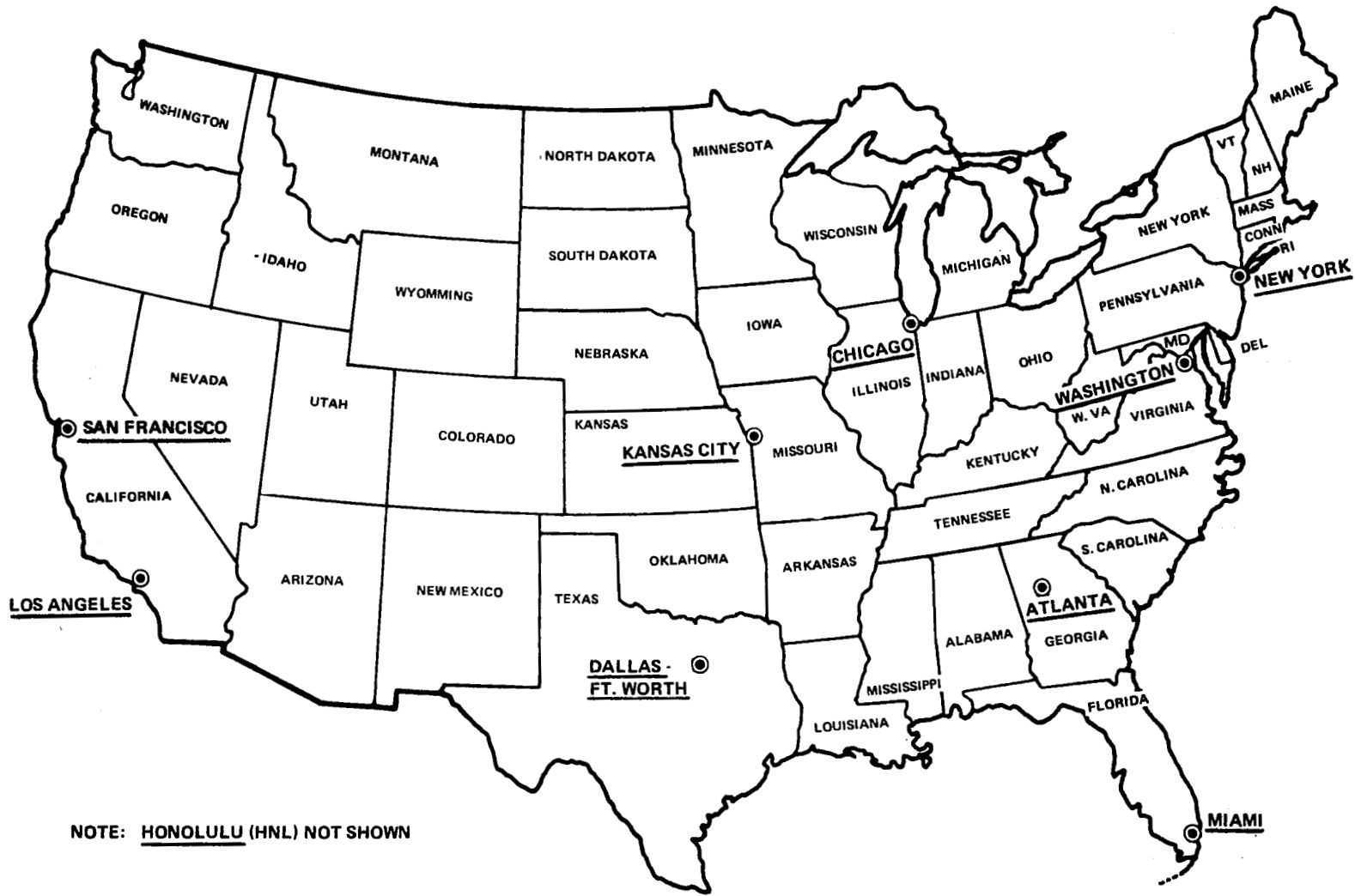

Figure 7. Ten Airports Projected for Initial LH<sub>2</sub> Facilities

LH<sub>2</sub> Demand Estimation Procedure (1995 - 2000) International:

The international consumption was calculated in a similar manner with the following exceptions:

- a. The only direct international flights from SFO in 1973 were to Tokyo (TYO). Since it was felt that by 2000 A.D. direct flights to Europe will be justified, they were arbitrarily added to the 1973 schedule as follows:

<u>City</u>	<u>Flts/Wk</u>
TYO	14 - Actual
LHR	7
CDG	7
FCO	4

} Assumed

- b. The 1973 payload factor for international flights was 0.35 from Ref. 6.
- c. The 2000 A.D. payload factor is estimated to be 0.65.
- d. The growth of enplanements for international traffic from 1973 to 2000 is a factor of 4.014 (0.292 to 1.172 x 10<sup>6</sup>), from Ref. 5.

Results of the calculations are shown in Tables IV, V, and VI. It should be noted that the quantities of fuel shown are those required for loading in the aircraft and do not reflect losses in production, storage, or transfer. Actual plant output will consider these losses as well as excess capacity required for outage of production units.

As a result of the foregoing assessment, the schedule shown in Figure 8 was formulated to represent a feasible sequence and timing for installation of liquid hydrogen facilities at the subject airports. The schedule for construction of facilities at the U.S. domestic airports is of interest, not only because it enters into the planning for fuel and aircraft handling facilities at SFO itself, but also because it affects the schedule for construction of total gaseous hydrogen manufacturing capability in the U.S. The schedule for instituting LH<sub>2</sub> use at foreign airports is useful in this study only as it affects planning at SFO.

A period of 30 months is provided for conceptual design and analysis of candidate arrangements of airport facilities. Final detail design of a preferred arrangement would be completed in 6 to 8 months and construction could be expected to take 36 months.

TABLE IV. PROJECTION OF TOTAL ENPLANEMENTS TO 2000 A.D.  
(LH<sub>2</sub> Aircraft From SFO)

Interstate:		1973		2000	
Connection to	$\frac{(\text{Enp})^{(1)}}{(\text{Mo})}$ Peak	$\frac{(\text{Enp/Mo}) \text{ Peak}^{(2)}}{(\text{Enp/Mo}) \text{ 11 Mo Avg}}$	$\frac{\text{Enp}^{(3)}}{\text{Yr}}$	Growth <sup>(4)</sup> Ratio	$\frac{\text{Enp}}{\text{Yr}} = (3) (4)$
ORD	58 740	1.331	545 000	1.9735	1 075 580
HNL	41 210	↓	383 000	↓	755 870
JFK	39 980	↓	371 000	↓	732 180
DFW	37 580	↓	348 000	↓	686 790
ATL	10 740	↓	99 800	↓	196 960
IAD	10 460	↓	97 000	↓	191 430
MIA	9 080	↓	75 000	↓	148 000
MCI	7 750	↓	71 800	↓	141 700
LAX	24 090	↓	223 000	↓	440 100
Total LH <sub>2</sub>			2 213 600		4 368 610
Total Interstate (Jet A + LH <sub>2</sub> )			5 670 000		11 190 000
% LH <sub>2</sub> Travel					39.04%

International:

TYO	8 040	1.34	74 050	4.014	297 240
LHR	4 020	↓	37 020	↓	148 600
CDG	4 020	↓	37 020	↓	148 600
FCO	2 300	↓	21 180	↓	85 020
Total LH <sub>2</sub>			169 270		679 460
Total International (Jet A + LH <sub>2</sub> )					1 172 000
% LH <sub>2</sub> Travel					58.0%

Enp = Enplanements: Passenger Boardings

(1) Calculated from Ref 6 using seating capacity, flight frequency and 1973 load factor from Ref 5.

(2) Calculated from Ref 5.

(3)  $\frac{\text{Enp}}{\text{Yr}} = (1) \left( \frac{11}{(2)} + 1 \right)$

(4) From Ref 6.

TABLE V. PROJECTED TOTAL FUEL LOADED - LH<sub>2</sub> AIRCRAFT AT SFO  
(400 Pax - 10 192 km (5500 n.mi.) Aircraft)

Interstate 2000 A.D. PLF = 0.64 (Ref. 4)  
PAX/FLT = 256

City	Flts/Yr (1)	ESAD		Block Fuel (2)		Total/Yr = (1) (2)	
		km	(n.mi.)	kg	(lb)	10 <sup>6</sup> kg	(10 <sup>6</sup> lb)
ORD	4201	2687	(1450)	6 985	(15 400)	29.346	(64.695)
HNL	2953	4295	(2318)	10 433	(23 000)	30.808	(67.919)
JFK	2860	3702	(1998)	9 072	(20 000)	25.946	(57.200)
DFW	2682	2209	(1192)	5 942	(13 100)	15.937	(35.134)
ATL	769	3095	(1670)	7 802	(17 200)	6.001	(13.227)
IAD	748	3500	(1889)	8 618	(19 000)	6.447	(14.212)
MIA	578	3847	(2076)	9 435	(20 800)	5.453	(12.022)
MCI	554	2142	(1156)	5 851	(12 900)	3.242	( 7.147)
LAX	1720	515	( 278)	2 132	( 4 700)	3.667	( 8.084)
Subtotal						126.85	(279.640)
+ 5% Losses						6.34	( 13.98)
Total						133.19	(293.62)

International 2000 A.D. PLF = 0.65 (Ref. 4)  
PAX/FLT = 260

TYO	1143	9497	(5125)	22 226	(49 000)	25.4	(56.007)
LHR	572	8220	(4436)	19 278	(42 500)	11.03	(24.310)
CDG	572	8576	(4628)	20 095	(44 300)	11.49	(25.340)
FCO	326	9615	(5189)	22 549	(49 700)	7.35	(16.203)
Subtotal						55.28	(121.860)
+ 5% Losses						2.76	( 6.090)
Total						58.0	(127.950)

$$(1) \text{ FLTS/YR} = \frac{\text{ENP/YR}}{\text{PAX/Flt.}}$$

ESAD = Equivalent still air distance

PLF = Passenger load factor

TABLE VI. SUMMARY OF LH<sub>2</sub> LOADED AT SFO - 2000 A.D.

	10 <sup>3</sup> kg/yr(1) (tons/yr)	Ratio(2) Peak/Avg	*11 Mo/Avg (3) 10 <sup>3</sup> kg/mo (tons/mo)	**Peak Month (4) 10 <sup>3</sup> kg/mo (tons/mo)	11 Mo Avg 10 <sup>3</sup> kg/day (tons/day)	Peak Month kg/day (tons/day)
Interstate	133 192 (146 816)	1.331	10 801 (11 906)	14 376 (15 847)	(355.7 (392.1)	463.8 (511.2)
International	58 038 ( 63 975)	1.57	4 617 ( 5 089)	7 249 ( 7 991)	152.0 (167.6)	233.9 (257.8)
Total	131 224 (210 785)		15 418 (16 995)	21 625 (23 838)	507.7 (559.7)	696.7 (768.0)

$$* \text{ Tons/month (Average)} = \frac{(1)}{11 + (2)}$$

$$** \text{ Tons/month (Peak)} = (3) \times (2)$$





The construction schedule of the airport facilities is arranged approximately in order of the fuel required per year at SFO to service flights to the designated cities. The exception is Honolulu which requires slightly more fuel per year for flights from SFO, than do flights from SFO to Chicago. The Chicago airport was scheduled for earlier construction because the problem of supplying  $\text{GH}_2$  to Chicago was considered to be simpler.

San Francisco and Chicago are provided with  $\text{LH}_2$  facilities as the initial city-pair, with operational capability to begin in 1995, the year gaseous hydrogen is scheduled to become available, see Figure 5. After a two year delay which provides for development and operational troubleshooting of the new facilities, additional airports come onstream at the rate of two per year domestically, plus one foreign airport. By 2000 A.D. all 10 domestic and 4 foreign airports are equipped with  $\text{LH}_2$  facilities.

For convenient reference, the quantity of  $\text{LH}_2$  loaded at SFO per year for flights to each of the specified cities is listed. Losses which will be incurred during loading are not included; however, the 5 percent loss assumed to occur during use in the aircraft is included. These data come from Table V. On the same basis, the total quantities of  $\text{LH}_2$  loaded at SFO each year are shown on Figure 9.

3.2.3 Airport fueling facility design flow rate. - The design requirement for fuel flow rate for the  $\text{LH}_2$  fueling facility at SFO was based on the following criteria:

- Aircraft departure times for all interstate plus international flights for August 1973 flight schedules (taken from Ref. 6), adjusted for the flight frequencies predicted for 2000 A.D.
- Refueling times commensurate with today's practice, i.e., approximately 38 minutes to refuel the subject aircraft for its total fuel load (based on current practice with 747's).\*

As an example, the subject 400 passenger, 10 192 km (5500 n.mi.) range, internal-tank design of  $\text{LH}_2$ -fueled aircraft requires a total of 27 942 kg (61 600 lb) of fuel. Consistent with the above requirement that refueling be accomplished in 38 minutes, and including 5 percent excess to account for boiloff from the aircraft tanks, this requires an average fuel flow rate of

$$w_f = 726 \text{ kg/min} \left(1600 \frac{\text{lb}}{\text{min}}\right) \times 1.05 = 762 \text{ kg/min} \left(1680 \frac{\text{lb}}{\text{min}}\right) \text{ or}$$

$$13 \text{ kg/sec} \left(28 \frac{\text{lb}}{\text{sec}}\right) \text{ per aircraft}$$

---

\*As subsequently pointed out in Task 9 it is recognized that this refueling time is considered excessive. Future analyses should investigate the feasibility of 30 minutes for a full fuel load.

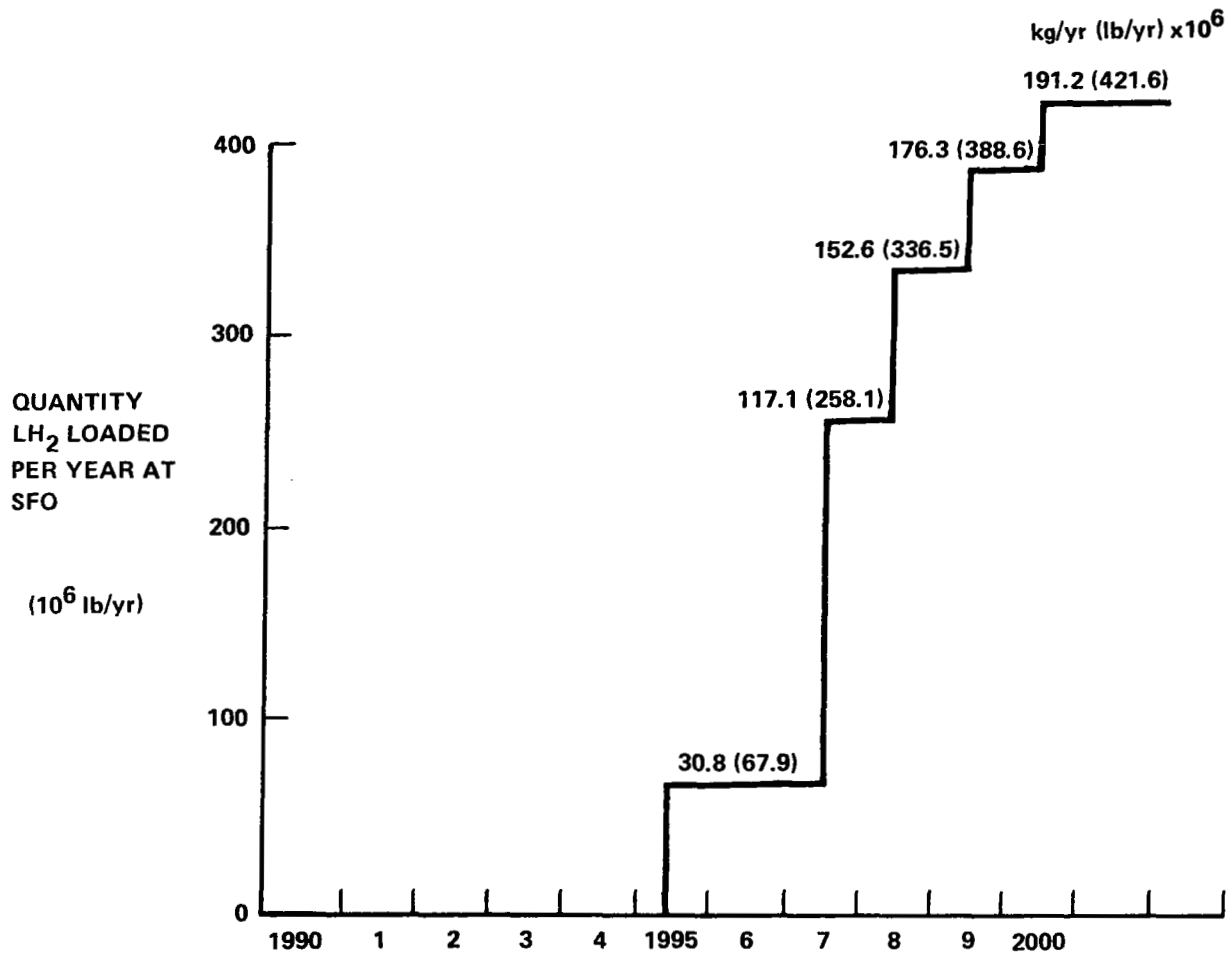

Figure 9. Total Quantity of LH<sub>2</sub> Loaded per Year at SFO

3.2.4 Data summary. - Table VII presents a summary of data relative to enplanements of the LH<sub>2</sub>-fueled aircraft at SFO with the airlines and destinations noted. It also shows corresponding flow rates of LH<sub>2</sub> which are required for the ground facility to accommodate the flight schedules. The data are presented as a function of time of day for an average day in the peak month (August) in 2000 A.D. With the information presented, the number of gate positions and refueling stations required at SFO can be determined and the ground operations analyzed. These items, plus the statement in Table VII of the total amount of LH<sub>2</sub> required on an average day in the peak month, viz., 697 730 kg/day (768 tons/day), constitute the information required from Task 2.

#### 4. PHASE II - DESIGN AND EVALUATION OF SYSTEM ELEMENTS

Overall requirements for the quantity and flow/rate of LH<sub>2</sub> which will be needed at SFO in 2000 A.D. were established in Phase I. In Phase II, the characteristics and requirements of facilities, equipment, and services which will be needed to operate the subject LH<sub>2</sub>-fueled long range transport aircraft are examined.

##### 4.1 Task 3: Hydrogen Supply Methods

The object of this task was to select a suitable and economic method for the supply of liquid hydrogen to the airport site in sufficient quantity to meet scheduled aircraft fueling requirements. The principal decision made was that of locating the site for the hydrogen liquefaction facility. The required area for a plant of the capacity contemplated is quite large and for reasons of property availability and/or cost, the plant might have to be located at some distance from the airport.

For the study, three different methods of transporting liquid hydrogen between the hydrogen liquefier and liquid hydrogen receiving-storage tanks located at the airport were considered:

- a. Vacuum jacketed pipeline (VJ)
- b. Truck-trailer using existing commercial vehicles of 50.0m<sup>3</sup> (13 200 gal) capacity.
- c. Railroad tank car using existing commercial railcars of 107.1m<sup>3</sup> (28 300 gal) capacity.

A source of crude (96.6% purity) gaseous hydrogen was assumed to be available at a distance of 161 km (100 miles) from the airport. The economics of hydrogen transport as a function of distance of the liquefaction facility from the airport was determined for distances of 161, 80.2, 16.1, 8.02, 1.61 and 0 (at the airport) km (100, 50, 10, 5, 1 and 0 miles).



4.1.1 Evaluation of distribution system losses. - Distribution system losses will amount to a considerable percentage of the aircraft block fuel requirements so that, prior to evaluating the economics of liquid hydrogen supply systems, an estimate had to be made of the magnitude of these losses. This was done in considerable detail on an assumed fueling circuit arrangement and included fueling circuit losses, aircraft on-board losses, and connection losses between the aircraft and fueling system (see Appendix A). Although the assumed fueling circuit configuration does not agree precisely with the final Task 7 version, the similarity is sufficiently good to permit use in the economic comparisons of this task. The sum of the block fuel requirements, the fueling system losses, and the transport losses constitutes the total quantity of LH<sub>2</sub> which must be produced by the liquefier and transported to the airport.

Table VIII summarizes the estimated losses for each of eight different combinations of transport and tank operations comprised of four transport methods and two tank operating methods.

Transport methods:

- a. On-site liquefier - no transport
- b. Truck-trailer transport
- c. Railcar transport
- d. Vacuum insulated pipeline transport

Tank operating methods:

1. Uninterrupted fueling from full to empty tank, via pump, requiring only one tank pressurization.
2. Interrupted operation, via pump, fueling aircraft individually with tank pressurization required for each fueling operation.

Fueling losses are minimized, of course, with the on-site liquifier, when using the less severe method of tank operations (Method #1). In this situation, cumulative losses amount to 15.7 percent of net engine fuel requirements. Losses increase to 23.5 percent with intermittent type of tank operations (Method #2).

Cumulative losses due to operations plus transport are least for VJ pipeline transport of liquid over nearly the entire 161 km (100 mile) distance. Pipeline losses are a strong function of distance while losses incurred in trailer or tankcar transport are nearly independent of distance. Shorthaul losses are much smaller for VJ transport while long-haul losses are comparable for distances of 80.2 to 161 km (50 to 100 mile). Losses as great as 51.9 percent are possible and apply to the combination of trailer haulage and intermittent fueling operations.

Losses were also determined for pressure transfer type of tank operations and although not summarized in Table VIII, the detailed results may be found in Appendix A. Because of the need for frequent blow down and repressurization operations and because of the relatively great pressure required for transfer, tank losses alone are extremely high and will amount to 52.7 percent. The combined overall loss for this system, including refueling and transport (tankcar) loss, amount to 185 percent of net engine requirements.

Table IX summarizes vehicle operations. For peak-month operation, at least 270 trailer trips or 121 tankcar trips and perhaps as many as 307 trailer trips or 139 tankcar trips would be required daily. Such a large volume of traffic at SFO would virtually preclude vehicle delivery of LH<sub>2</sub> to the airport site.

Vehicle operating costs are also presented in Table IX as a function of distance and tank operating method. The tank car costs are for a leased locomotive or unit train approach. Daily operating costs for trailer and tankcar crossover at a distance of about 80.47 km (50 miles) and at \$50 000, with trailer favored for shorter distances and railcar for longer. Trailer transport costs are fairly sensitive to distance because of change in driving time while railcar costs are not very sensitive to distance because a large proportion of the cost results from switching, etc. required at filling and emptying locations. Costs shown include amortization of the capital cost of the vehicles (\$180 000 for the trailer and \$400 000 for the tankcar) but not of pumps, piping, etc. in the fueling circuit. Table IX also lists fleet requirements for both trailer and tankcar operations.

4.1.2 Hydrogen gas pipeline. - The cost for transporting 8.888 kg/s (846.5 tons/day) of gaseous hydrogen from the hydrogen source to the liquefier for distances of 80.2 to 161 km (50 to 100 miles) via pipeline is shown in Table X and Figure 10. The cost includes investment in a 76.2 cm (30 in.) diameter pipe (optimally selected), as well as investment and operating cost for associated compressors. The total cost is defined as the present value of investment plus operating costs via discounted cash flow techniques. More specific information concerning the basis for the cost evaluation is presented in section 4.1.7, Economic analysis for present value.

4.1.3 Vacuum jacketed pipeline. - Pipeline transmission of liquid hydrogen requires high-performance insulation to minimize heat transfer to the liquid within the pipe. This study assumes commercially available piping consisting of concentric pipes containing multiradiation shielded insulation in the evacuated annulus. The liquid hydrogen is piped directly from the hydrogen liquefier to the receiving storage tank at the airport site. Available pressure energy in the product stream of the liquefier is used as motive force for transmitting the liquid hydrogen. Sufficient pressure is maintained on the liquid at all locations to prevent occurrence of two-phase flow within the lines. Liquid losses resulting from heat in leakage as well as from frictional sources are considered to be pipeline operating cost. For present

TABLE VIII.  $LH_2$  BOILOFF LOSSES AND PRODUCTION REQUIREMENTS  
FOR VARIOUS SUPPLY METHODS

[Net  $LH_2$  Required to Engines = 7.68 kg/s (731.4 tons/day)]

	Tank Method No. 1		Tank Method No. 2	
	Loss %	Cumulative %	Loss %	Cumulative %
<b>LOSSES:</b>				
<u>Trailer Transport</u>				
Refueling operations (1)	12.2	12.2	12.2	12.2
Tank operations	3.2	15.7	10.0	23.5
Vehicle operations	11.8	29.4	11.8	38.1
Tank operations (2)	3.2	33.5	10.0	51.9
<u>Tank Car Transport</u>				
Refueling operations (1)	12.2	12.2	12.2	12.2
Tank operations	3.2	15.7	10.0	23.5
Vehicle operations	9.0	26.1	9.0	34.5
Tank operations (2)	3.2	30.1	10.0	48.4
<u>Vacuum Pipeline Transport</u>				
Refueling operations (1)	12.2	12.2	12.2	12.2
Tank operations	3.2	15.7	10.0	23.5
Pipeline operations:				
<u>Distance</u>	<u>km</u>	<u>miles</u>		
	1.61	(1)	0.3	16.1
	8.02	(5)	1.4	17.4
	16.1	(10)	2.8	19.0
	80.2	(50)	10.4	27.8
	161.0	(100)	17.5	36.1
			0.3	23.8
			1.4	25.1
			2.8	26.9
			10.4	36.3
			17.5	45.0
<b>PRODUCTION REQUIREMENTS:</b>				
On-site liquefier	8.89	(846.5)	9.48	(903.0)
Trailer	10.25	(976.5)	11.67	(1111.0)
Tank car	9.99	(951.7)	11.40	(1085.6)
Vacuum jacketed pipeline:				
<u>Distance</u>	<u>km</u>	<u>miles</u>		
	1.61	(1)	8.92	(849.2)
	8.02	(5)	9.02	(858.7)
	16.1	(10)	9.14	(870.4)
	80.2	(50)	9.81	(934.7)
	161.9	(100)	10.45	(995.4)
			9.51	(905.5)
			9.61	(915.0)
			9.74	(928.1)
			10.47	(996.9)
			11.14	(1060.5)

(1) From storage tank to aircraft fuel tank.

(2) For filling vehicles.



TABLE IX. SUMMARY OF VEHICLE OPERATIONS

<u>Tank Method</u>	<u>Required Trips per Day</u>	
	<u>Trailer</u> 3284 kg/trip (7240 lb/trip)	<u>Tank Car</u> 7123 kg/trip (15 703 lb/trip)
No. 1	270.0	122.0
No. 2	307.0	139.0

Cost of Transporting Required Liquid Hydrogen  
Between Two Sets of Large Storage Tanks

<u>One-Way Distance</u> <u>km (miles)</u>	<u>Trailer</u>			<u>Tank Car</u>		
	<u>\$ Per Trip</u>	<u>\$ Per Day</u>		<u>\$ Per Trip</u>	<u>\$ Per Day</u>	
		<u>Tank Method No.</u>			<u>Tank Method No.</u>	
		<u>1</u>	<u>2</u>		<u>1</u>	<u>2</u>
1.61 ( 1)	72	19 426	22 097	331	40 117	45 777
8.02 ( 5)	80	21 584	24 552	335	40 602	46 331
16.1 ( 10)	90	24 282	27 621	340	41 208	47 022
80.2 ( 50)	170	45 866	52 173	380	46 056	52 554
161.0 (100)	270	72 846	82 863	430	52 116	59 469

Number of Vehicles Required  
(Including Spares for Maintenance etc.)

<u>One-Way Distance</u> <u>km (miles)</u>	<u>Trailer</u>		<u>Railcar</u>	
	<u>Tank Method No.</u>		<u>Tank Method No.</u>	
	<u>1</u>	<u>2</u>	<u>1</u>	<u>2</u>
1.61 ( 1)	89	101	157	179
8.02 ( 5)	97	110	159	181
16.1 ( 10)	109	124	161	184
80.2 ( 50)	210	239	181	206
161.0 (100)	331	377	204	233

TABLE X. TOTAL COST (PRESENT VALUE) OF GASEOUS HYDROGEN PIPELINE

Pipeline distance - km	80.2	145.0	153.0	159.0	161.0
- miles	<u>(50)</u>	<u>(90)</u>	<u>(95)</u>	<u>(99)</u>	<u>(100)</u>
<u>Costs in Millions of Dollars</u>					
Investment					
Pipeline	17.3	30.65	32.35	33.72	34.06
Compressor	<u>1.65</u>	<u>2.78</u>	<u>2.92</u>	<u>3.02</u>	<u>3.05</u>
Total	18.68	33.43	35.27	36.74	37.11
Operating cost	0.805	1.358	1.424	1.476	1.488
Present value					
Investment	17.09	32.08	33.84	35.26	35.61
Operating cost	<u>3.37</u>	<u>5.69</u>	<u>5.96</u>	<u>6.18</u>	<u>6.23</u>
Total	20.46	37.77	39.80	41.44	41.84

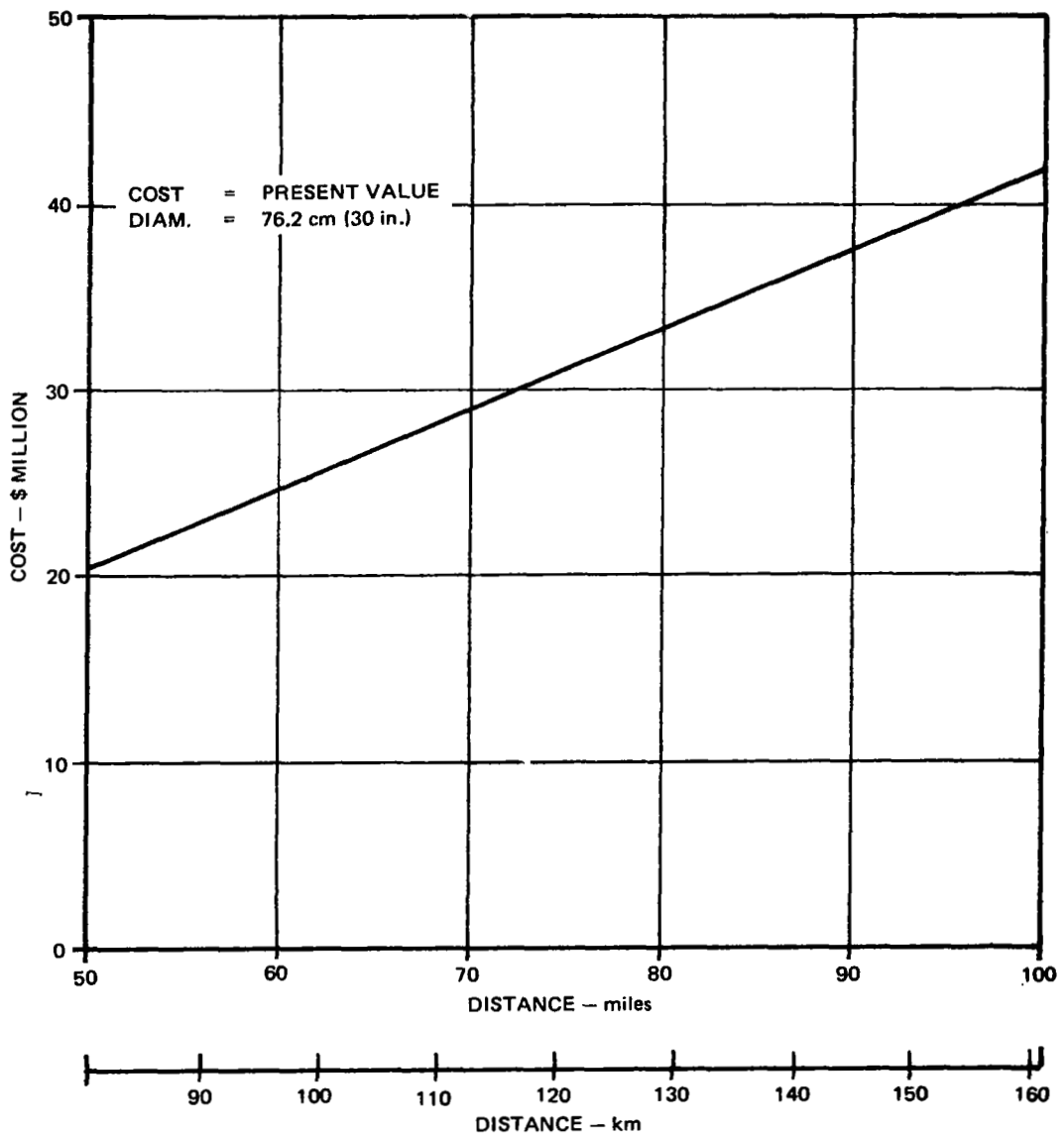

Figure 10. Total Cost of Gaseous Hydrogen Pipeline

purposes, the lost hydrogen is assumed to be nonrecoverable. Table XI presents a summary of installed cost of VJ pipeline for pipeline distances of from 1.61 to 161 km (1 to 100 miles) for the delivery of 8.888 kg/s (846.5 tons/day) of hydrogen liquid into the airport storage tank.

For purposes of developing the economics for the Task 3 study, a unit cost of LH<sub>2</sub>, amounting to \$5.69/GJ (\$6/10<sup>6</sup> Btu) based on gross heating value or 80.82¢/kg (36.66¢/lb), was selected from a previous study (Ref. 7). The actual cost of liquid hydrogen at SFO was later determined in the Task 6 study to be about 12 percent greater (Section 5.1.2.3).

4.1.4 Truck-trailer transport. - A summary of loss analysis for trailer transport of liquid hydrogen is presented in Table VIII. In order to supply 7.680 kg/s (731.4 tons per day) net fuel to the engines, 8.888 kg/s (846.5 tons per day) must be supplied into the on-site storage tanks (assuming tank method #1) and 10.253 kg/s (976.5 tons per day) must be liquefied. The difference between 10.253 and 8.888 = 1.365 kg/s (976.5 and 846.5 = 130 tons per day) represents the vaporization loss incurred as a result of trailer operations. Trailer transport requires an additional set of storage tanks at the liquefier site which are used for receiving hydrogen from the liquefier and for dispensing it to the trailers. Investment for these tanks is included in the cost of trailer operation. The investment in a maintenance building for the truck fleet as well as filling stations at the liquefaction and airport sites is also included. Table XII presents a cost summary for trailer transport operations.

TABLE XI. TOTAL COST (PRESENT VALUE) OF TRANSMITTING LIQUID HYDROGEN VIA VACUUM JACKETED PIPELINE

Pipeline distance	- km	1.61	8.02	16.1	80.2	161
	- miles	(1)	(5)	(10)	(50)	(100)
Pipe diameter	- cm	20.3	20.3	20.3	25.4	30.5
	- inches	(8)	(8)	(8)	(10)	(12)
Costs in Millions of Dollars						
Investment		1.85	9.24	18.48	106.13	239.71
Annual operating cost		0.644	3.257	6.624	25.945	46.567
Present value						
Investment		1.77	8.87	17.73	101.84	230.02
Operating cost		2.70	13.64	27.75	108.68	195.06
Total		4.47	22.51	45.48	210.52	425.08

TABLE XII. TOTAL COST (PRESENT VALUE) OF TRANSPORTING LIQUID HYDROGEN VIA TRUCK-TRAILER (TANK METHOD NO. 1)

Distance - km	1.61	8.02	16.1	80.5	160.1
- miles	<u>(1)</u>	<u>(5)</u>	<u>(10)</u>	<u>(50)</u>	<u>(100)</u>

Costs in Millions of Dollars

Investment

Tanks	12.3	12.3	12.3	12.3	12.3
Building	1.2	1.2	1.2	1.2	1.2
Filling station	0.59	0.59	0.59	0.59	0.59
Vehicles	<u>2.17</u>	<u>2.36</u>	<u>2.66</u>	<u>5.12</u>	<u>8.08</u>
Total	<u>16.26</u>	<u>16.45</u>	<u>16.75</u>	<u>19.21</u>	<u>22.17</u>

Operating cost

Evaporation loss	34.79	34.79	34.79	34.79	34.79
Vehicles	<u>4.92</u>	<u>5.52</u>	<u>6.20</u>	<u>11.62</u>	<u>18.51</u>
Total	<u>39.71</u>	<u>40.31</u>	<u>40.99</u>	<u>46.41</u>	<u>53.30</u>

Present value

Investment	15.61	15.80	16.08	18.44	21.28
Operating cost	<u>166.35</u>	<u>168.83</u>	<u>171.71</u>	<u>194.40</u>	<u>223.28</u>
Total	<u>181.96</u>	<u>184.63</u>	<u>187.79</u>	<u>212.84</u>	<u>244.56</u>

4.1.5 Tank car transport. - Tank car transport is analagous to truck-trailer transport except that a larger load of liquid hydrogen is hauled each trip. As a result, there are fewer fillings and evaporation losses are less: 1.105 vs 1.365 kg/s (105.2 vs 130.0 tons/day). An additional set of storage tanks and a pair of filling stations are again required. There is no need for a maintenance building on the assumption that the need for maintenance work will be much less and that for the occasional maintenance required, the car would be returned to the manufacturer's shops. A railroad siding and switching spur will be required at each filling station location. Table XIII summarizes the cost of tank car operations.

4.1.6 Comparison of transport methods. - Figure 11 presents a comparison of total cost of transporting hydrogen over the 161 km (100 mile) distance from the source of gaseous hydrogen to the airport, on a present value basis for truck-trailer, railway tank car, and vacuum insulated pipe transport. The values include the cost of the gas pipeline (Table X) for transporting the gas to the hydrogen liquefier. Transport via VJ pipeline is the most economical method at distances less than 64.4 km (40 miles), while transport via tankcar is the most economical method at distances greater than 64.4 km (40 miles). Cost of vehicular transport, whether by trailer or tankcar, is a weak function of distance, particularly for distances of 16.1 km (10 miles) or less. This is the result of the cost of evaporization losses incurred in filling and transport operations which accounts for about 75 percent of the total cost.

An interesting relationship is the decrease in cost for tankcar transport with increasing distance which is the result of a lower incremental cost per mile for the tankcar than for the gas pipeline. If liquid hydrogen is to be transported, for whatever reason, by tank car, it is economically advantageous to locate the liquefier at the hydrogen source and transport LH<sub>2</sub> the entire 161 km (100 mile) distance.

Figure 12 is a bar graph showing the distribution of costs for the three modes of transport over a 16.1 km (10 mile) distance. The major impact of the liquid evaporation loss on the total cost is readily apparent.

It is concluded that the most economical arrangement for supply of LH<sub>2</sub> is that which locates the liquefier at the airport itself. Total transportation cost is only that for transporting the gas over a 161 km (100 mile) distance, and amounts to \$41.84 million (Table X). However, it costs very little more to locate the liquefier 1.61 km (one mile) from the airport and transport the LH<sub>2</sub> via vacuum jacketed pipeline. Total cost for this configuration is \$45.91 million. Beyond this, the cost increases at an increasing rate. Therefore, if for reasons of space availability or of real estate values, it is impossible or inappropriate to locate the liquefier at the airport site, the next best configuration is that which locates the liquefier as close as possible to the airport with transfer of LH<sub>2</sub> to the airport via VJ pipeline.

TABLE XIII. TOTAL COST (PRESENT VALUE) OF TRANSPORTING LIQUID HYDROGEN VIA RAILROAD TANK CAR (TANK METHOD NO. 1)

Distance - km	1.61	8.05	16.1	80.2	161.0
- miles	<u>(1)</u>	<u>(5)</u>	<u>(10)</u>	<u>(50)</u>	<u>(100)</u>
<u>Costs in Millions of Dollars</u>					
Investment					
Tanks	12.30	12.30	12.30	12.30	12.30
Siding	0.35	0.35	0.35	0.35	0.35
Filling station	0.25	0.25	0.25	0.25	0.25
Vehicles	8.49	8.58	8.72	9.78	11.06
Total	<u>21.39</u>	<u>21.48</u>	<u>21.62</u>	<u>22.68</u>	<u>23.96</u>
Operating cost					
Evaporation loss	28.15	28.15	28.15	28.15	28.15
Vehicles	6.15	6.24	6.33	7.03	7.96
Total	<u>34.30</u>	<u>34.39</u>	<u>34.48</u>	<u>35.18</u>	<u>36.12</u>
Present value					
Investment	20.53	20.61	20.74	21.76	22.99
Operating cost	<u>143.68</u>	<u>144.05</u>	<u>144.42</u>	<u>147.39</u>	<u>151.28</u>
Total	<u>164.21</u>	<u>164.66</u>	<u>165.16</u>	<u>169.15</u>	<u>174.27</u>

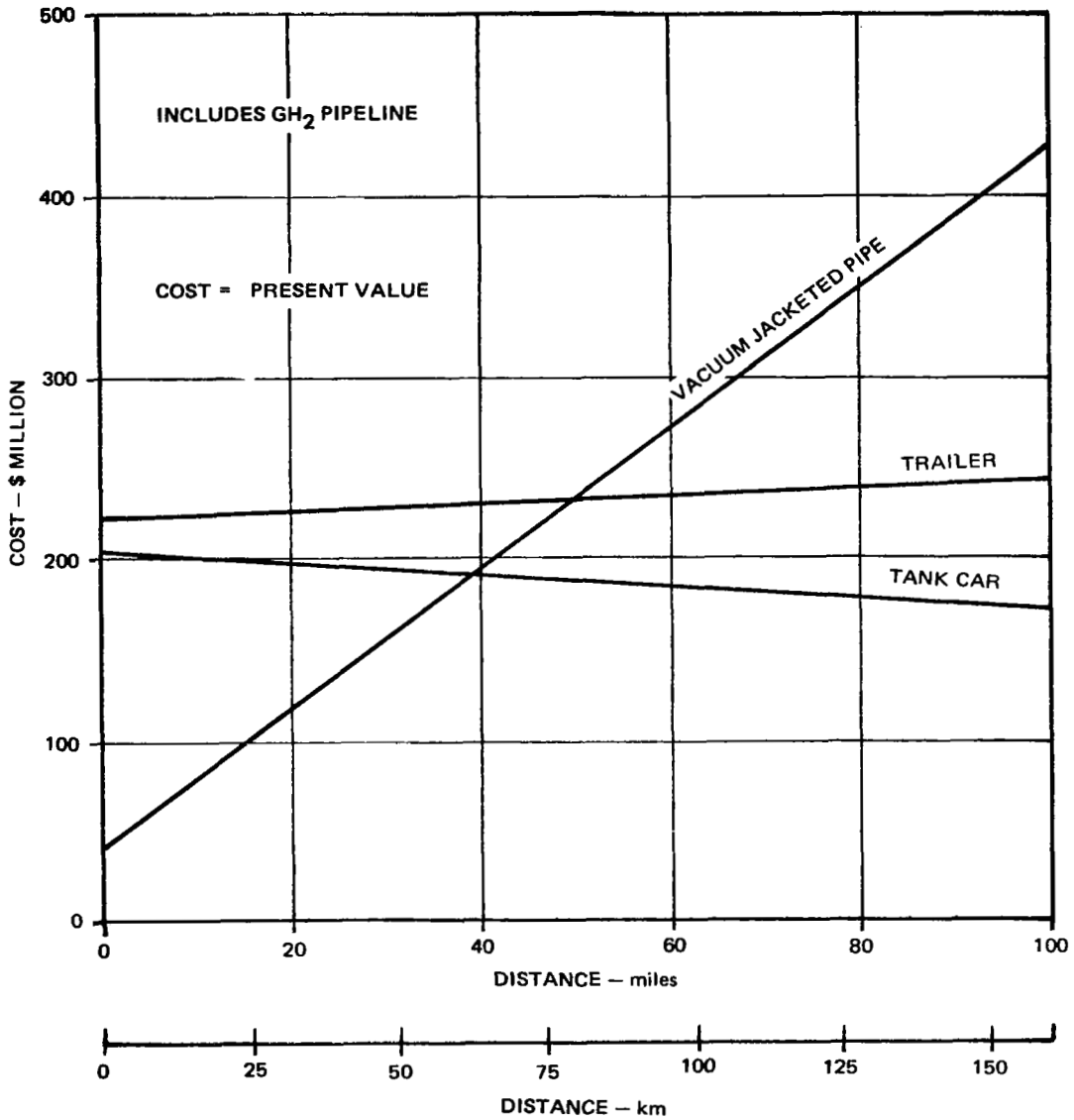

Figure 11. Total Cost of Transporting Hydrogen Gas and Liquid vs Liquefier Distance From Airport



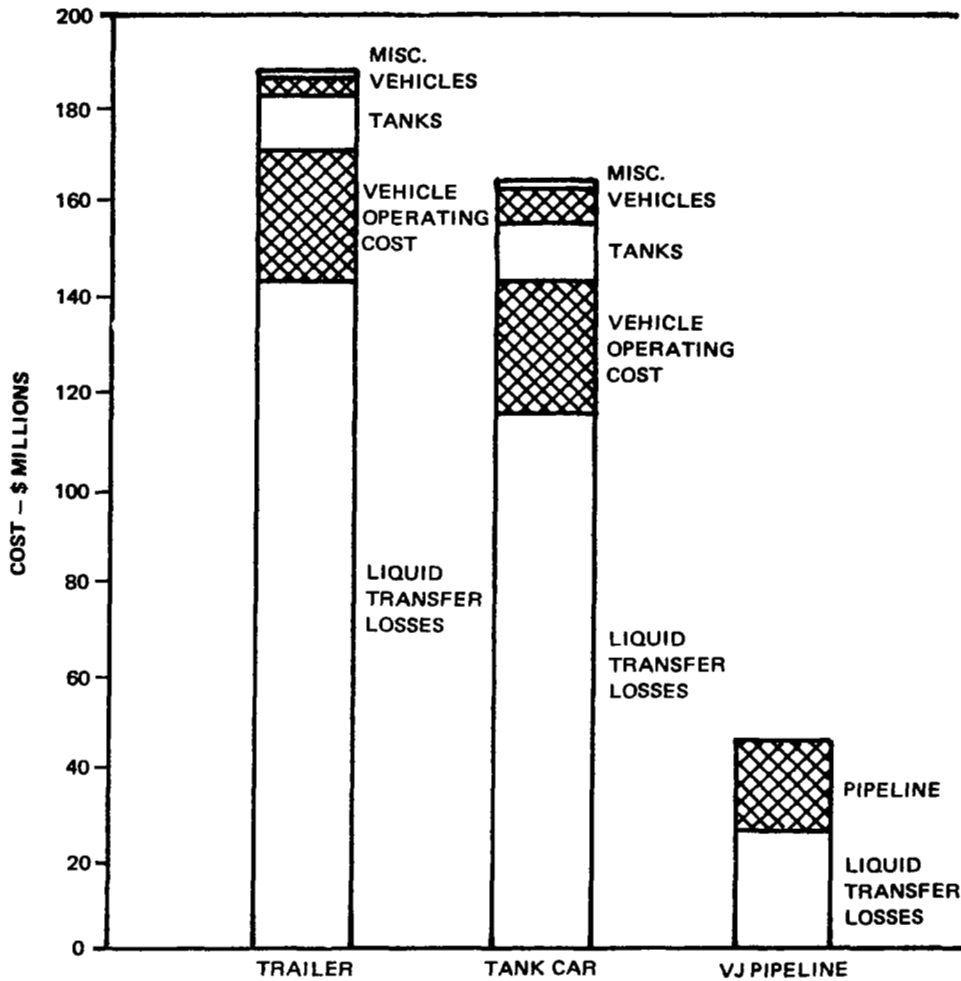

Figure 12. Cost for Liquid Hydrogen Transport Over 16.1 km (10 mile) Distance

Emphasis is placed on the specificity of these economics to the particular set of assumptions assigned, for purposes of this study, to the various modes of transport. This particular comparison should not be construed as having general validity.

4.1.7 Economic analysis for present value. - Economics for Task 3 are based on the discounted cash flow (DCF) method of accounting. The DCF method accounts for the time value of money and converts all expenditures and revenues occurring at different periods of time to a common basis which is the "present value." It is through present value comparisons that equitable economic judgements can be made on combined investment and operating costs. The analysis can readily be modified to account for inflation if so desired but is not included in this case.

Present value is the amount of money which would have to be invested at the present time and at the discounted rate of return to meet all costs and expenses of building and operating the facility over the project life. The present value of investment is the actual investment because of the assumption that total investment occurs now, in year zero. Annually recurring costs will have different present values depending upon the year in which the cost was incurred. At 12 percent discount rate, a \$1 expenditure in the fifth year would have a present value of 56.7 cents, while the same expenditure in the 10th year would have a present value of only 32.2 cents. Any other expense incurred at a future date would have a present value which is less than the actual expense. Present values of investment and of operating cost are arithmetically additive and the total present value as given by Equation (1) is the sum of the present values of all expenditures over the life of the project. It is also the total present value of all the annually recurring income that must be received in payment for the facility in question under the basic concept that income must equal expenditures. Recognition of this equality aids in the understanding of the income tax effect which is included in Equation (5).

The income tax effect simply acknowledges that, through income tax, the government shares our losses as well as our profits. Therefore, an expenditure has a net effect of being only 52 percent of the actual value of the expenditure because, if it were not incurred, 48 percent of that value would be paid instead as income tax. For example; suppose that a project under consideration has a gross income of \$300 and expenditures of \$150. The net income is \$150 and income tax on this would amount to 48 percent of \$150 or \$72. If, on the other hand, expenditures were \$200, net income would now be \$100 on which \$48 tax would be paid. The net income after taxes for the first case is \$78 compared with \$52 for the second case and the difference of \$26 is exactly equal to 52 percent of the additional \$50 paid out in expenses. Therefore, in Equation (5), we can take only 52 percent of the annual operating cost as the net expense. Depreciation, on the other hand, is revenue and not an expenditure. It is a cash inflow required for recovery of capital expenditure. Income tax is assessed directly on this and Equation (4) shows that we get to keep only 52 percent of it. Equation (7) observes that depreciation is a revenue by subtracting its present value from the present values of investment and operating cost to obtain the net present value of

expenditures. Income tax is therefore not being assessed on expenditures. Rather, it is in reality being assessed on implied net revenues, the latter being necessary in order to continue business operations.

Using the DCF method, total costs were derived as the sum of the present values of investment and operating costs which are calculated using the assumptions listed in Table XIV. The following relationship was derived for calculating present value:

$$PV = 4.1887 (AOC) + 0.95956 (I) + 0.52(S) + 0.9666 (W) \quad (1)$$

where

PV = Total present value, \$ million

AOC = Annual operating cost, \$ million/year

I = Investment, \$ million

S = Startup costs, \$ million

W = Working capital, \$ million

The preceding equation is derived as follows:

The total operating cost over a 30-year project life is a cash outflow and is

$$= 30 (AOC) \quad (2)$$

Depreciation is a periodic cash inflow which decreases over the depreciation period. Total depreciation allowance is given as

$$= \sum_{n=1}^{n=16} (I \times SYDD) \quad (3)$$

where SYDD = sum of the years' digits depreciation factor.

The federal income tax that did not have to be paid because of depreciation allowance can be subtracted from the investment dollar giving a net cash inflow for depreciation of

$$= 0.52 \sum_{n=1}^{n=16} (I \times SYDD) \quad (4)$$

TABLE XIV. ASSUMPTIONS FOR ECONOMIC ANALYSIS

1. Discounted cash flow financing
2. 30 year project life
3. 16 year sum of the years' digits depreciation of investment
4. 100% equity capital
5. 12% discounted rate of return
6. 48% Federal income tax rate
7. Mid-1975 dollars, no escalation
8. Investment, return on investment and working capital treated as capital costs in year 0
9. Startup costs are treated as an expense in year 0
10. Return on investment during construction based on 1.875 years

Similarly, the net operating cost, accounting for federal income tax is

$$= 0.52 (\text{AOC}) \quad (5)$$

Each of these (depreciation on investment and operating cost) is now converted to present value through use of the discount factor, which is defined as follows:

$$\text{DF} = \frac{1}{(1 + i)^n} \quad (6)$$

where

DF = discount factor

i = discounted rate of return

n = number of years

The present value of the net cash outflow resulting from investment, operating cost and depreciation is given by

$$PV = I + 0.52 \sum_{n=1}^{n=30} (DF \times AOC) - 0.52 \sum_{n=1}^{n=16} (DF \times SYDD \times I) \quad (7)$$

This equation recognizes investment as a cash outflow in year zero.

Applying numerical values for discount and depreciation factors gives the following simplified equation for present value.

$$PV = 0.73456 (I) + 4.1887 (AOC) \quad (8)$$

The return on investment during the assumed 1.875 year construction period is a cash outflow which must be added to the preceding equation.

$$\begin{aligned} IDC \text{ (Investment During Construction)} &= 1.875 (i) (I) \\ &= 1.875 (0.12) (I) = 0.225 (I) \end{aligned} \quad (9)$$

The resulting expression for present value now becomes

$$PV = 0.95956 (I) + 4.1887 (AOC) \quad (10)$$

This foreshortened equation was used for economic comparisons for Task 3 transport methods. It assumes zero values for startup costs and working capital. These can be included by taking working capital as a capital expense in year zero and startup cost as an operating expense in the same year. The working capital is recovered in the 30th year. The following equation gives the present value of startup costs and working capital.

$$\begin{aligned} &= W (1 - DF_{n=30}) + 0.52 (S) \\ &= 0.9666 (W) + 0.52 (S) \end{aligned} \quad (11)$$

The addition of equations (10) and (11) gives equation (1).

#### 4.2 Task 4: Fueling Operations

The object of this task was to select an appropriate and technically feasible method of fueling the LH<sub>2</sub> aircraft in the context of the selected airport and its other needs. Toward this end, four alternative fueling operations were evaluated and one procedure was selected for development in

the remaining tasks. It is emphasized that the selected system is the one considered most appropriate for San Francisco International Airport, and that it may not necessarily be the best for another facility. The development of an optimum ground operations system exclusively for an LH<sub>2</sub> fleet at a new airport location, or at an airport that might be subject to major reconfiguration, might be based on a very different approach than that adopted for this study.

It should also be noted that selection of a workable operational procedure for fueling the LH<sub>2</sub> transport in scheduled commercial passenger service involves consideration of the philosophy of ground time segment planning in route structuring. Also involved are hazard criteria, the impact on airport operations, airline and airport labor precedents, airport revenue bond obligations, system constructibility, and a wide variety of air transportation system considerations. Detailed study of these questions was beyond the scope of this preliminary investigation; the impact of these matters are included only to the extent of intuitive judgment as to their probable effects.

4.2.1 Program and plans at SFO. - As indicated in the forecasts of Task 2, SFO is expected to reach a saturation condition at about 31 million annual passenger movements in approximately 1989. Physical expansion of the runway system is not feasible and the airport is finally constrained by the capacity of that system to serve aircraft. Regional, local, state, and federal airport system plans accept the 31 million passenger level as an upper bound. The passenger capacity could grow slightly over the long term if aircraft larger than those forecast for service in 1989 were to replace that fleet and/or air traffic control procedures are altered to improve runway efficiency, but such additional growth would be nominal. Thus, the time period for this study deals with an established and essentially static volume of annual traffic.

A construction program is currently underway which is designed to provide sufficient terminal capacity for the 31 million annual passenger movements. In 1973, the total cost of this expansion program was estimated to be in the neighborhood of \$400 million, including terminal, airside, and land-side improvements. The completed terminal will provide 81 aircraft gates on six satellite boarding areas around a central ground transportation complex. Gate usage is exclusive to the tenant airlines; one spare gate is designated and limited further expansion capability is provided for in the form of a potential concourse addition which could add three or four gates. It is difficult to envision a need for additional terminal capacity beyond that currently programmed and available through the additional concourse.

The expansion program is being funded principally through the sale of airport revenue bonds. These will be long term obligations of the airport, and will not be retired within the period of this study. This has significance in that capital expenditures required to support a transition to LH<sub>2</sub>-fueled aircraft should be considered in the light of a zero-growth airport with extensive financial obligations.

Figure 13 is a sketch of SFO showing improvements planned for the terminal, effective in 1985. The general configuration of the probable 1985 Jet A fuel supply system is indicated, as is the configuration of the aprons and terminal complex, gate assignments and major airport tenant leaseholds planned for 1985. Current property limits are also shown.

4.2.2 Operational objectives. - Planning for domestic airline services usually considers two categories of airport terminals: the enroute station and the turnaround station. Enroute stations serve through flights and generally provide abbreviated services in the shortest feasible elapsed ground time. Turnaround stations (or originate/terminate stations) ordinarily provide full ground services to the aircraft, which will probably depart with a different flight number and crew than when it arrived. Clearly, an airport may be classed as an enroute station to one airline while it is a turnaround station to another line.

San Francisco International (SFO) is a turnaround station to most of the carriers using it. A few flights originate or terminate in Los Angeles and transit SFO enroute to long haul inland destinations, and a few others originate at inland points and transit SFO enroute to Hawaii, or vice versa. However, virtually all of the routes postulated in Task 2 originate or terminate at SFO, and require the full range of ground services. In practice, the Los Angeles services originating at SFO would probably fuel for their ultimate destination and transit LAX as an enroute station. Thus, the scheduled flights developed in Task 2 are assumed to require full ground services.

In commercial air transportation there is a maxim that the airplane is not performing any useful work, hence, not producing income, while it is on the ground. In developing routes and schedules, the operator will minimize scheduled ground time to increase aircraft utilization whenever practicable. There are, of course, criteria other than turnaround efficiency which are also important to the selection of a concept for refueling. Operational safety, efficiency of vehicle and aircraft ground traffic, the impact on terminal operations and passenger convenience, functional area adjacencies, and relative capital and operating costs are all of major importance.

The aircraft which are the subject of this study are, apart from their unique fuel requirement, essentially an advanced version of the larger air vehicles in today's fleet. With this thought in mind, it is worth noting that the ground operations procedures in use today are the result of evolutionary development over a long period of time. Accordingly, the ground handling procedures considered herein will adapt as much of the current practice as possible and the preferred system will, insofar as possible, minimize the time the aircraft spends on the ground.

4.2.3 Hazard criteria. - For purposes of fueling system evaluation in this study, it is considered and assumed that the storage and use of liquid hydrogen as an aircraft fuel is no more hazardous than similar use of Jet A fuel. Implicit in this assumption, however, is the fact that storage and use of both fuels are hazardous to some degree. The procedures and safeguards which

are in use at present for conventional jet aircraft operations and the storage and distribution of fuel are apparently effective, for the hazards have come to be generally accepted and the accident/incident history is statistically insignificant.

Procedures and safeguards for the storage, distribution, and use of liquid hydrogen as an aircraft fuel must similarly be developed. Under the governing assumption, the risk level is assumed to be more or less equal, but it is accepted that the nature of the hazards are different, hence, the safety precautions and operational procedures will be different. The storage and distribution safety criteria and procedures for LH<sub>2</sub> are discussed in some detail in Appendix B.

The refueling operation appears to involve three risk levels. The lowest risk is that directly associated with the integrity of the aircraft systems and their vulnerability to collision from ground equipment, i.e., the risk of operating the aircraft in the airport ground environment, with the fuel system closed except for normal boil-off venting. This risk level can be assumed to be equivalent to, or less than, that for conventional turbine aircraft in the same phase of operations.

A second level of exposure can be assigned to the brief periods before and after actual fuel transfer when the LH<sub>2</sub> and vent connections are made up and purified or are inerted and disconnected. During these brief periods, exposure is highest to mechanical, protective system, or human failures. Once connections are secure and proofed and actual transfer is in progress, the third level of risk might apply, being somewhat lower than the connection risk. With a properly designed process and adequate safeguards, these fueling operation hazards need be no greater than equivalent Jet A fueling hazards, and may be lower.

In terms of ground services, the area restricted to unsecured spark ignition vehicles during fueling operations will be larger for the LH<sub>2</sub> aircraft; however, the restricted area will be centered on the aircraft tail assembly, rather than the wing pressure fueling points as with conventional aircraft. Limited studies and experiments suggest that a radius of 27.43 m might be restricted to vehicles with ignition systems which have not been fully bonded or pressurized to prevent exposure to ignitable mixtures of GH<sub>2</sub> and air. If necessary, a family of diesel powered, compressed air start ground service equipment could be developed. Safeguards will also have to be provided to prevent intrusion of any accidentally released gaseous hydrogen into closed spaces, the nearest of which would be the aircraft cabin or cargo compartments. This can be accomplished by providing positive pressure in the passenger and cargo compartments during the fueling operation.

Aircraft cabins are maintained at a comfortable temperature during ground time, either through use of the onboard auxiliary power unit (APU) to drive the aircraft's air conditioning system, or through supply of pre-conditioned air from an external source. If the air supplied to the cabin is



sufficient to maintain a positive pressure with doors opened into a boarding bridge at the forward part of the cabin, and if the supply air to the air conditioning pack is isolated from potential gaseous hydrogen release, access to the cabin can be maintained during fueling.

In the worst case, it would be necessary to restrict other external aircraft services during refueling, and to reseal the cabin doors, although cabin servicing could continue in the environmentally conditioned aircraft with the doors closed. This presumes a supply of air from one or more air conditioning units with remote intakes, or from a central source. The onboard auxiliary power unit could be used if air intake is isolated. The limited data available indicates that these precautions are probably unnecessary; however, until proper studies and experiments have been conducted, precautions should be taken. Accordingly, this worst case condition has been used as a basis for the elapsed time analysis of the candidate loading procedures which follows.

4.2.4 Candidate loading procedures. - Four alternative procedures for performing all necessary operations at a turnaround air terminal were examined in the context of anticipated conditions at SFO in 1995 - 2000. The four procedures were:

- All aircraft are parked and fueled at gate positions physically close to the terminal, as at most air terminals of today.
- Aircraft to be fueled are parked at gates physically removed and possibly structurally protected from the terminal, with an extended connector for passenger loading.
- Aircraft are fueled in an isolated area (at least 182.88 m from the terminal) with conventional docking before and after fueling operation.
- Aircraft are fueled in an isolated area with transporter connection to the terminal.

In order to evaluate these candidate procedures properly, the various operations which are performed at turnaround air terminals were organized into 7 groups and assigned time intervals as follows. The activities and durations listed are typical of current 747 aircraft ground operations based on 90 percent load factors for both passengers and cargo.

- Arrival Sequence: Engine rundown, position bridges, attach ground support equipment (GSE), and deplane passengers. For gate and transporter services, nine minutes is assumed; if the aircraft is to be moved to an isolated location, 11 minutes is used to permit boarding bridges to be cleared.
- Offloading: 25 minutes is assigned to offload all baggage and cargo, assumed to be fully containerized in the time period of this study (i.e., no bulk cargo).



LEGEND

--- PROPOSED 1990 JET A FUEL SYSTEM

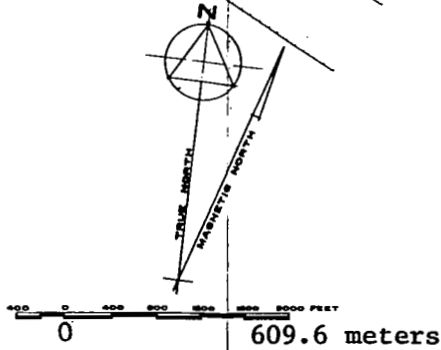
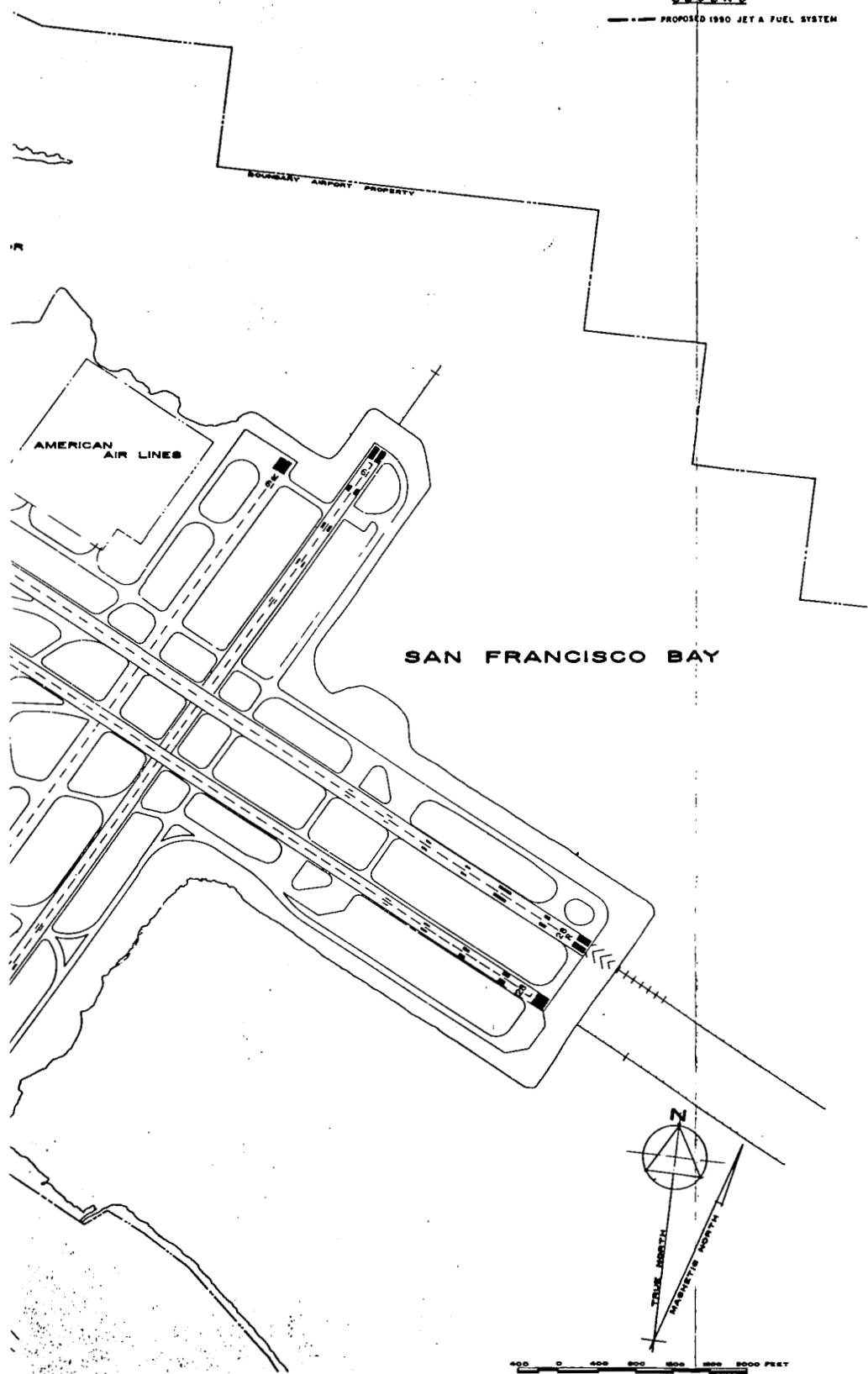

Figure 13. San Francisco International Airport, 1985 Plan

- Ramp Services: All of the conventional services to the aircraft are grouped under this heading. These include galley service, potable water, lavatory services, walk-around inspections, and miscellaneous. A total of 38 minutes is assumed required, but the time may be discontinuous.
- Cabin Service: Ordinarily on the critical path, this activity is assigned 41 minutes, typical of currently achieved service times for a fully loaded Boeing 747 at a turnaround station. This is assumed to be approximately equivalent to the study aircraft, in terms of passenger loads.
- Fueling: Includes assumed times of 4 minutes to make up the necessary connections, 12-1/2 minutes for a typical transfer of fuel for the SFO-JFK segment (see Table VI Task 2), and 3-1/2 minutes to disconnect and secure the system, for a 20 minute activity total.
- Loading: The same 25 minutes assumed for offloading is needed to reload cargo and baggage containers and clear the access doors.
- Departure Sequence: 14 minutes is assumed required to enplane passengers, start engines, and clear GSE and boarding bridges. For the isolated fueling case, 16 minutes is used to allow for repositioning boarding bridges when the aircraft returns to the gate.

These seven activity groups have been plotted for each of the four candidate loading systems for fueling LH<sub>2</sub> aircraft, as shown in Figure 14. For comparative purposes, the figure also illustrates ground times which are representative of typical practice with a conventionally fueled 747 aircraft. It is emphasized that Figure 14 was developed early in the study to permit a comparative evaluation of the fueling cases under the most stringent conditions. They were based on a set of preliminary assumptions which do not present a later, more considered, view of the conditions under which fueling can occur and which are therefore not consistent with later work. These early assumptions were that no ramp services or loading/off-loading operations would be permitted during the fueling operation, and that cabin doors would be sealed for that time, although cabin service would continue.

The schedules presented in Task 2 were translated into approximate gate demand, by carrier, assuming an average one hour turnaround for domestic services and 90 minutes for international services, see Figure 15. A composite demand curve is also shown at the bottom of the figure, indicating the theoretical total airport LH<sub>2</sub> gate demand if all carriers shared facilities, could turn the aircraft around within the target times, and could be assured of meeting schedules without delays. The composite demand has significance in assessing potential transporter systems.

The figure shows that of the 81 gates which will be available at SFO subsequent to 1985, 19 will be required for the subject LH<sub>2</sub>-fueled aircraft under the assumed conditions and on the customary basis that gates are leased for the exclusive use of tenant airlines. If the other approach is used,

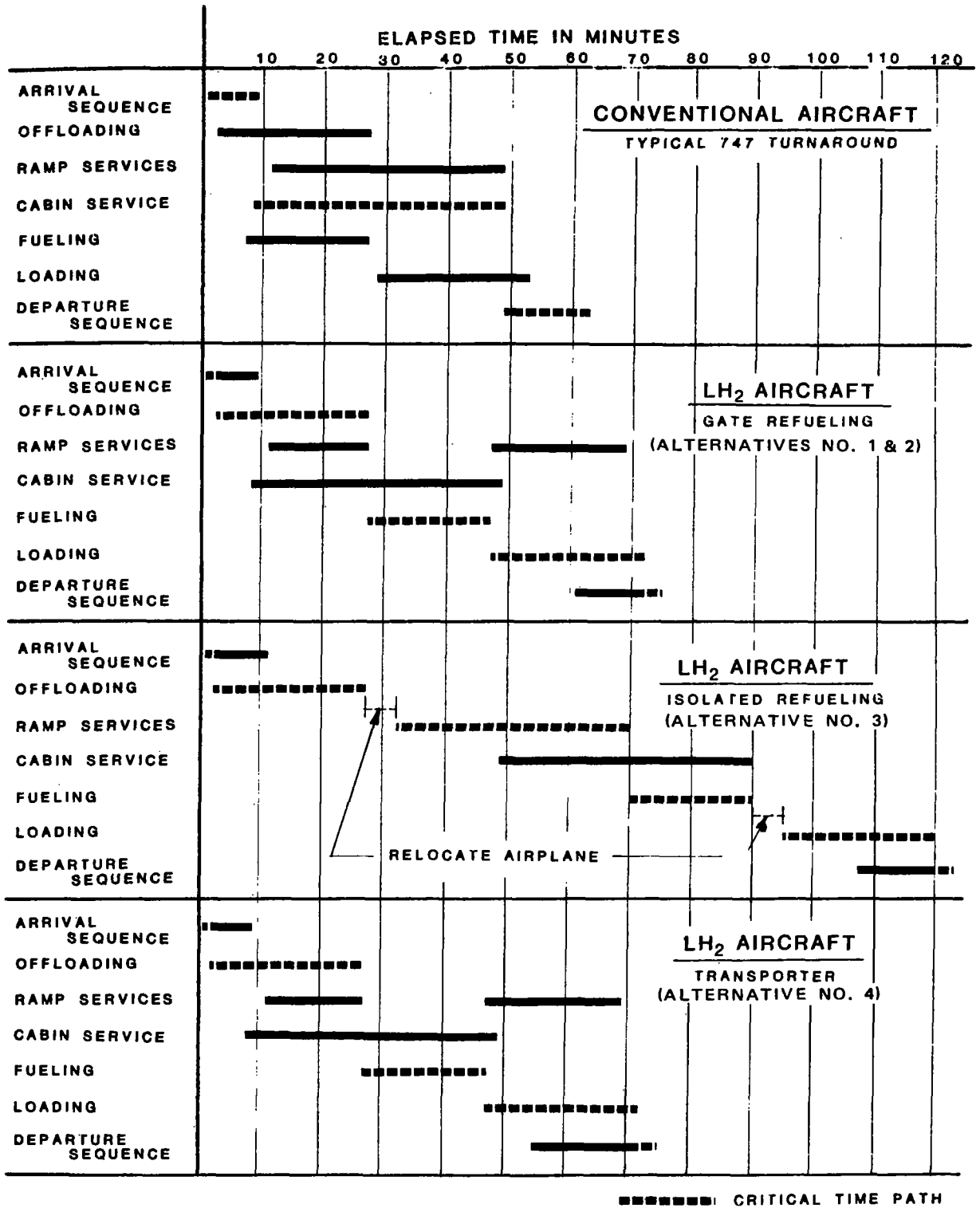

Figure 14. Comparison of Alternate Ground Handling Procedures

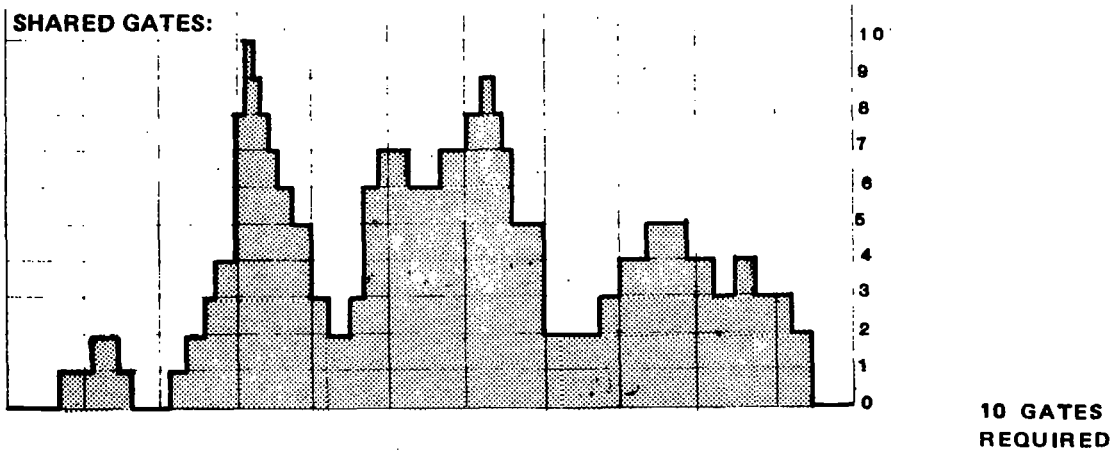
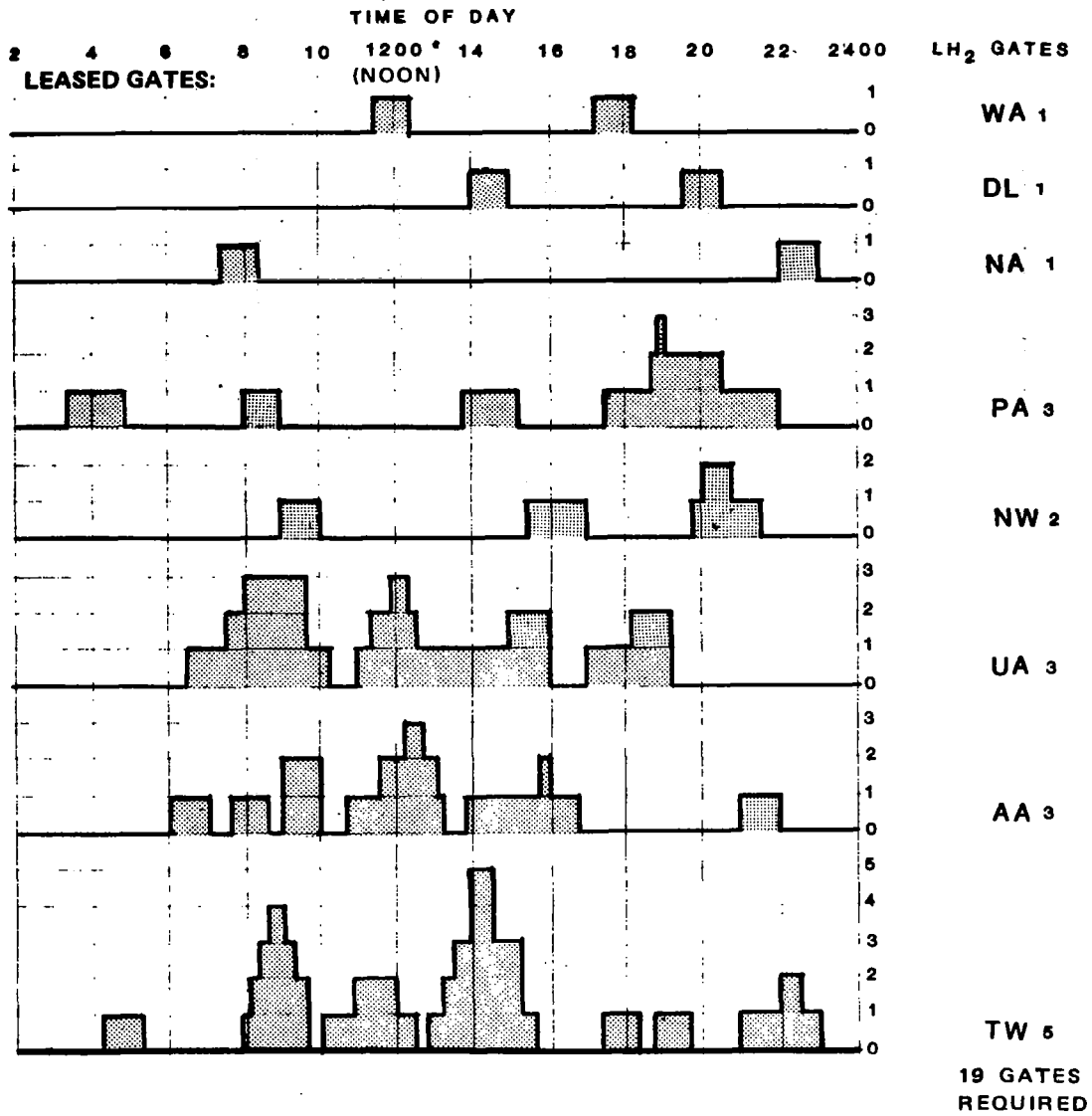

Figure 15. L<sub>2</sub> Gate Requirements

i.e., if the carriers share gate facilities, only 10 gates would be needed to serve the needs of the LH<sub>2</sub> aircraft at SFO in 2000 A.D. Although this reduction from 19 to 10 gates would represent a significant saving it must be realized that the saving would be temporary since more LH<sub>2</sub> aircraft will be put in service in succeeding years. The shared gate approach is a good candidate for those airports which are short of space for terminal facilities. However, since SFO is runway critical, the leased gate approach is used as a basis for the LH<sub>2</sub> requirements analysis.

As previously described, the alternatives for fueling include: 1) at conventional gates, as now; 2) at conventional gates but physically removed and boarded through an extended connector; 3) at an isolated location, with enplaning, deplaning, and servicing performed at conventional gates, moving the aircraft before and after fueling; and 4) at an isolated gate location with a version of transporter for enplaning and deplaning.

The physical constraints at SFO militate against Alternative No. 2. It is not possible to provide significant physical separation of aircraft from the passenger terminal without major reconstruction of the terminal area.

Alternative No. 3 yielded a turnaround time of about 2 hours for trans-continental services as shown in Figure 14. The only feasible locations for remote refueling at SFO are 2682 m (8800 feet) from the gates. These are areas which could be developed by land reclamation in the seaplane basin, or in the area south of the runway intersections (see Figure 13). The distance of 2682 m (8800 feet) assumes movement around the runways. Although cross runway movement is possible, the delays would probably eliminate the time benefits of the shorter distance. As shown in Figure 14, 5 minutes has been assigned for moving the aircraft to/from the terminal gate. It was assumed the aircraft would be moved without the use of the aircraft engines by utilizing a high speed tractor capable of towing aircraft at speeds of 48-56 km (30-35 mph) (References 8 and 9). Allowing for maneuvering of aircraft into and out of gate positions and fueling stands, an average speed of 32 km (20 mph) has been assumed for the aircraft relocation. The loading/offloading sequences are on the critical path, along with the fueling operation. If the assumed restriction against services during fueling was lifted, this time would be shortened somewhat. However, this would mean marshalling and handling cargo containers at the isolated location and result in long hauls from the cargo complex to the refueling area. It would be necessary, in any case, to offload and reload baggage containers at the gate to avoid long delays in preloading containers and bag retrieval. This function often uses equipment and labor common to the cargo container handling function, so duplication of equipment and effort would be required. In all probability, all offloading and loading would be performed at the gate, despite the turnaround penalties.

The ramp services were charted as being performed at the isolated location in order to permit cabin service to begin prior to completion of other ramp services. This again suggests duplication of equipment and labor, as the terminal gates must be served in any case. Further, a sizeable

installation would be required at the isolated location, defeating much of the purpose of isolation. Alternatively, the isolated location might be used only for fueling, and the turnaround sequence extended slightly. The general undesirability of this option, characterized by longer turnaround times and additional equipment and personnel requirements, led to its rejection.

The turnaround chart developed for the transporter operation (Figure 14) indicates the same elapsed ground time as a gate operation. Published schedules would, of course, be different, as flight close out times would be earlier and arrival times are for first transporter at the dock. To understand the implications of converting part of SFO to transporter operations, the following description of such an operation is offered.

Referring to Figure 15, if the carriers would agree to the shared use of transporter gates, a minimum of ten such gates would be required. A complex to support ten to twelve new transporter gates might be constructed, perhaps on reclaimed land in the seaplane basin, and supplied with liquid hydrogen. The turnaround chart is based on expediting the deplaneing/enplaneing activity; this requires three transporters for the LH<sub>2</sub> airplane. In the peak hour, some 30 transporter trips would be required and a 22 minute average cycle time is a reasonable assumption for the location of the complex in relation to terminals and runways. Using a nomograph developed for the purpose (Reference 10), some 14 transporters would be required at something like \$300 000 each. Although the carriers might be induced to share the remote gates, their transporter docks should be located in their respective terminal areas, if possible. Thus, docking facilities would have to be developed for each of the eight airlines, necessitating alteration or reconstruction of several gate areas at the terminal.

Comments concerning duplication of equipment and labor for the isolated refueling case are equally applicable to the partial transporter operation. It is also important to envision the trains of container vehicles traversing the route between remote gates and the terminal during peak hours, suggesting the need to develop an extensive roadway system either through the congested areas west of the runways, or, perhaps, via a tunnel under the runways.

A very valid reason for converting an airport terminal complex to partial use of transporters is that additional passenger handling capacity can be gained when terminal expansion is difficult or costly, or if there are other constraints on adding gate facilities. In the case of SFO, however, the runways provide the capacity constraint, and additional passenger handling capacity is neither useful or desirable. In fact, the facilities currently under construction would not be fully utilized, jeopardizing the ability to repay the revenue bondholders. Additional capital projects are required while a major investment is not fully productive. More importantly, the operating costs to the tenant airlines will increase significantly without benefits in terms of improved capacity.



The transporter approach does offer attractive advantages in terms of the fuel distribution system requirements. Construction costs for the system would be much lower than for the gate service option, and operating losses and system maintenance cost would be significantly less. At another airport where other benefits of a transporter operation could be realized, the system might prove to be the best solution; however, for SFO its disadvantages clearly outweigh the potential advantages.

For these various reasons conventional terminal gate refueling was selected for evaluation. In addition, since the selected airport is similar to many existing large hubs with elements of linear, pier, and satellite terminals, selection of the gate refueling system affords the advantage that the results will represent the technical feasibility and costs of implementing a conventional refueling system for a typical airport, using ground systems common to Jet A fueled aircraft.

4.2.5 Evaluation of external tank aircraft concept. - While the foregoing discussion has been directed primarily toward consideration of the internal tank airplane design, the implications of the external tank concept (Reference 2) in terms of the refueling operation have also been considered. Since single point refueling is possible with either airplane configuration, the two aircraft are not viewed as being radically different in terms of the recommended terminal gate refueling procedure (Section 4.5).

The external tank concept, however, offers the potential for a unique system of refueling in that a tank system could conceivably be developed wherein the tanks could be demounted for routine refueling and defueling. It is assumed that this activity would not be performed at the terminal gate but would require establishment of an additional station where the aircraft would stop for quick disconnect removal of tanks before proceeding to the gate. Upon completion of gate services, the departing aircraft would return to the fueling station for remounting of full LH<sub>2</sub> tanks.

From an operational standpoint, the refueling station should ideally be located so that additional taxi (or aircraft towing) distances are held to a minimum. However, the physical and site constraints at SFO would probably require that this facility be located such that either extremely long taxi distances or cross runway movement would be required. Other disadvantages of the system are that the stops for disconnect and reconnect of the tanks would require extra time, there would be an inevitable aircraft traffic problem at the tank removal station, the quick disconnect requirements of the system would introduce reliability and maintenance problems in the cryogenic fuel feed system, and the concept would require extra handling equipment and purchase of spare tanks. Considering these factors, the external tank airplane concept does not appear to offer advantages in terms of a refueling procedure appropriate for SFO.

4.2.6 System description. - Locations of the 19 gates selected for the LH<sub>2</sub> service concept are illustrated in Figure 16. In order to permit maximum gate utilization, it is assumed that Jet A fuel will continue to be provided to these same gates.

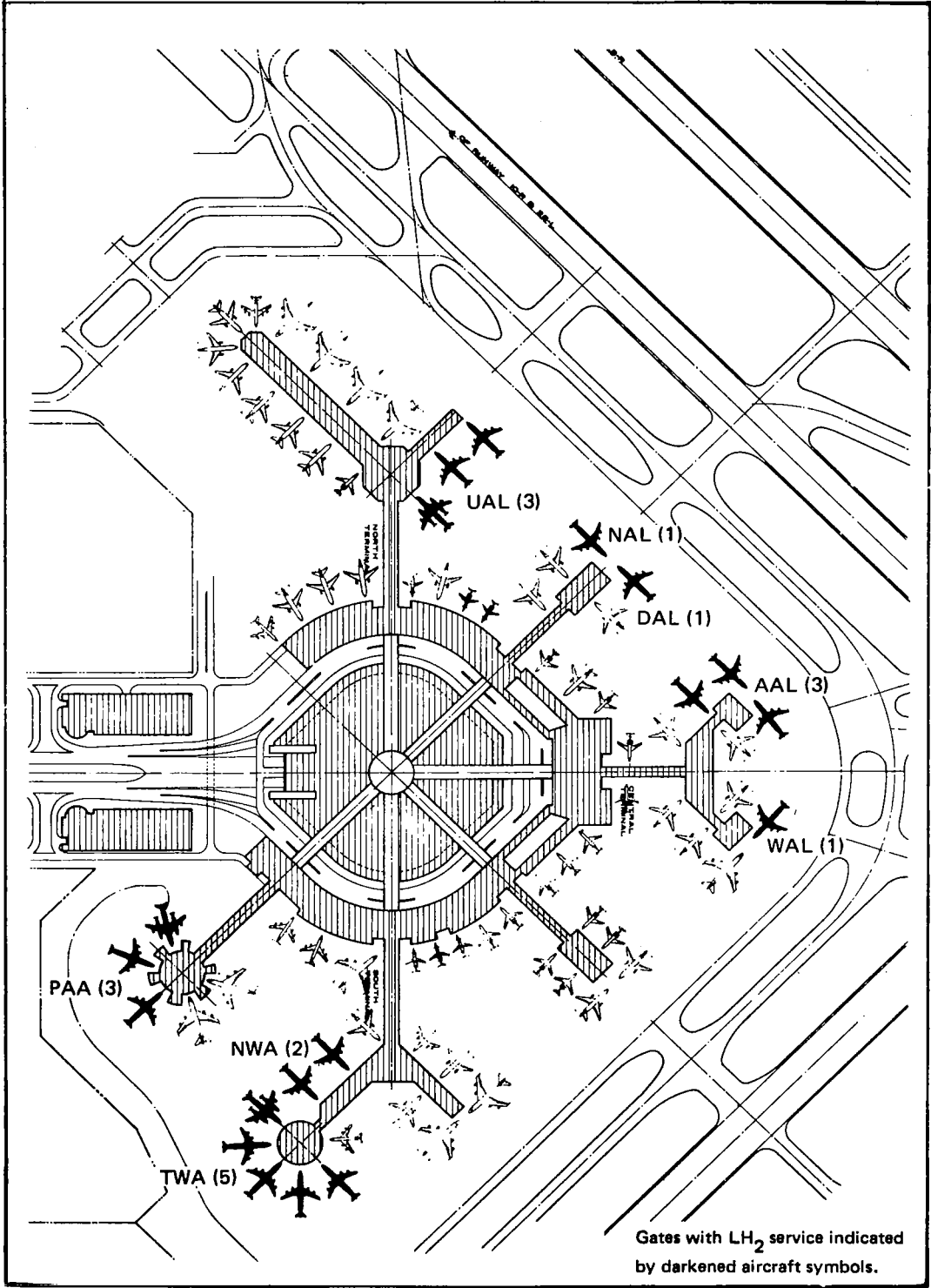

Figure 16. Gates With LH<sub>2</sub> Services

The reference LH<sub>2</sub>-fueled internal-tank aircraft is configured with the LH<sub>2</sub> fill connect point located in the tail cone of the fuselage. The tank vent piping is routed to the top of the vertical stabilizer and GH<sub>2</sub> is vented to atmosphere during flight and when the aircraft is parked at the gate, except during the fueling operation. During fueling, the LH<sub>2</sub> tank vent will be routed to a second connect point at the tail by means of a diverter valve.

At each gate fueling station the hydrant consists of an LH<sub>2</sub> valve and a GH<sub>2</sub> vent collection valve. These hydrant valves and their interface connections are in a pit located so as to be situated below the tail of the parked aircraft. The pit is normally covered with a load-bearing grating. The LH<sub>2</sub> valve is connected to a vacuum jacketed header for recycle to the storage and liquefaction facility. The GH<sub>2</sub> vent collection line returns the cold gaseous hydrogen to the liquefaction plant.

The fueling operation will be carried out by a hydrant fueler vehicle equipped to provide all necessary interfaces between the hydrant and the aircraft systems. A concept for the hydrant fueler is illustrated in Figure 17. Flex hose connections will be made from the hydrant truck to the LH<sub>2</sub> and vent valves in the pit. Simultaneously, a cherry picker type boom is raised to the aircraft tail cone where jacketed flex hoses are mated to the aircraft LH<sub>2</sub> and vent connect points. The hoses mated to the pit hydrants and to the aircraft are interconnected by vacuum jacketed piping on the fueler truck, complete with valves and instruments. The hydrant fueler truck will carry a vacuum pump, high pressure helium bottle and the necessary valves and controls to permit purification (the removal of all traces of air and moisture) of the flex hoses prior to the introduction of hydrogen. This system will also permit the flex hoses to be inerted after fueling and prior to disconnection.

Once the LH<sub>2</sub> and vent hoses have been connected, purified, and proofed (a helium pressure check of the connect points), the hydrant LH<sub>2</sub> and GH<sub>2</sub> vent valves will be opened. A bleed valve located inside the aircraft on the LH<sub>2</sub> line near the fill valve and routed to the vent will be opened to chill down the fueler truck piping and hoses, as well as a portion of the aircraft fill lines. The aircraft fill valve will then be opened and the tanks filled. This procedure minimizes addition of heat to the LH<sub>2</sub> which remains in the aircraft fuel tanks from the previous flight.

At the conclusion of the filling operation the aircraft valves and the hydrant valves will be closed and the hoses will be inerted prior to disconnection. The helium used for inerting both before and after the fueling operation will be vented into the hydrogen vent gas collection header and recycled to the liquefaction facility where it is separated from the hydrogen as a normal function of the liquefaction process. A large fraction of the helium can therefore be recycled for reuse in the hydrant fueler truck and similar functions.

In accordance with standard practice, aircraft would not remain at the terminal gate for extended periods. Only trip fueling as described above will be performed at the gate for aircraft with cold tanks. Chill-down and fueling

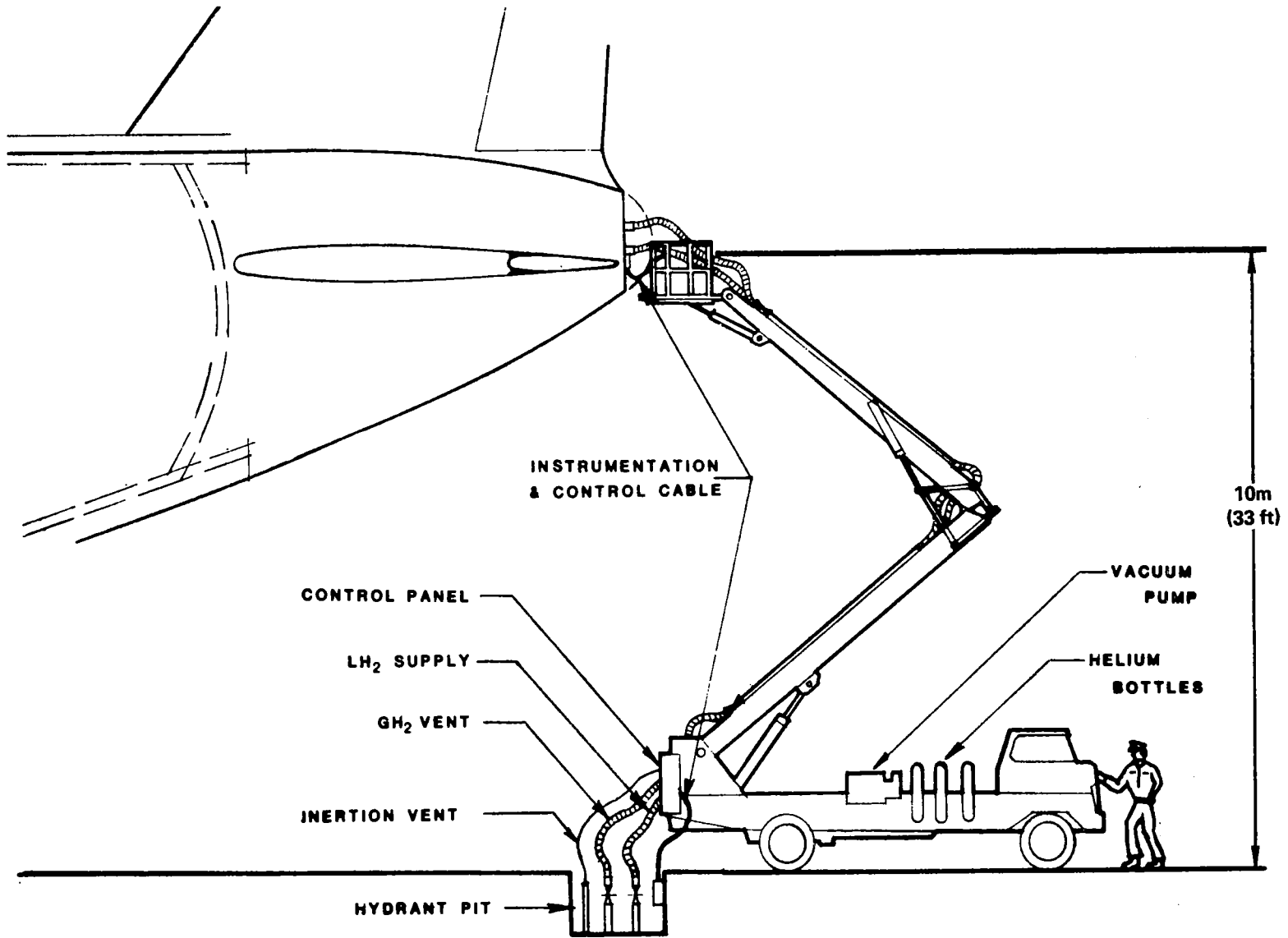

Figure 17. LH<sub>2</sub>-Hydrant Fueling-Truck Concept

of aircraft which have been out of service for an extended period, e.g., coming from major overhaul at the maintenance facilities, will be performed at a fueling point adjacent to the LH<sub>2</sub> storage facility (see Figure 31 in section 5.1). Several aircraft can be accommodated at these stands, which also serve as a defueling area for aircraft that are to be out-of-service for an extended period.

The refueling operation as described is considered to be a technically feasible concept which can be performed without significantly altering current procedures for servicing aircraft at existing terminal gates. A more detailed description of the refueling system is presented in Task 7.

#### 4.3 Task 5: Hydrogen Storage Evaluation

The primary objective of this task is to determine the type of container best suited to the storage of large quantities of liquid hydrogen at SFO. The types of containers which were studied include vacuum insulated double wall tanks using both powder insulation and multiple radiation shields, and non-vacuum foam-insulated single wall tanks. The performance and economics of each type of tank are examined and used as a basis for selection of the preferred tank. The merits of underground vs aboveground tanks are compared.

Task 5 objectives also include a determination of the capacity of the total storage facility, as well as the number and capacity of the individual tanks in the facility.

4.3.1 Tank farm requirements. - Liquid hydrogen storage tanks must be provided in adequate number and of sufficient capacity to serve two major functions.

- a. To provide dispensing and receiving containers to service the aircraft fueling system and to receive the liquid hydrogen product as it is produced from the hydrogen liquefiers.
- b. To provide backup capacity in order that fueling operations can continue in the event of outage of the liquefaction equipment or interruption of the feedstock (GH<sub>2</sub>) supply.

A minimum of three tanks is required for dispensing and receiving operations. One tank is used for dispensing, which requires that it be slightly pressurized to obtain sufficient NPSH for the dispensing pump which feeds LH<sub>2</sub> into the fueling circuit. The second tank is used for receiving liquid from the hydrogen liquefiers as well as excess liquid returned from the fueling circuit or from defueling of aircraft. This tank must operate at essentially atmospheric pressure so that in the subsequent dispensing phase of fueling, liquid hydrogen is delivered to the aircraft fuel tanks with maximum subcooling. The third tank serves as a full standby tank which can be pressurized to be ready for immediate switchover to dispensing service at the moment the dispensing tank becomes empty. The need for the full standby tank results from the near impossibility of scheduling receiving and dispensing

operations in such a way that an empty dispensing tank and a full receiving tank occur simultaneously. A three tank system provides the necessary flexibility in operations and permits decoupling of storage tank filling and emptying operations from aircraft fueling schedules.

Sufficient storage capacity is provided to permit uninterrupted aircraft fueling for a one-day period in event of total outage of all four liquefaction modules. Task 2 places average daily consumption, for peak months in the year 2000, at 696 700 kg (768.0 tons or 2 600 000 gallons). In the final configuration of the storage facility, at least 11 356 m<sup>3</sup> (3 000 000 gallons) are held in reserve at all times which provides 27.7 hours of backup during peak month operation or 38.0 hours of backup during off-peak, normal operation. The 11 356 m<sup>3</sup> (3 000 000 gallons) are contained in three 3786 m<sup>3</sup> (1 000 000 gallon) tanks, one of which is the full standby tank of the 3-tank receiving-dispensing set and the other two are used for storage purposes only. The total tank farm will therefore consist of five 3785 m<sup>3</sup> (1 000 000 gallon) tanks.

4.3.2 Underground vs aboveground tanks. - Underground installation of the storage tanks at SFO has been rejected because of inappropriate soil conditions. There is very little elevation above the surface of San Francisco Bay so that an underground installation would locate most of the storage tank below the water table level. Elaborate construction would be required to maintain physical integrity of the tank as well as good thermal performance. However, in the interests of completeness in this discussion, the merits of underground tanks are examined qualitatively.

A tank design suitable for LH<sub>2</sub> service must provide a high level of thermal performance. The large temperature difference between the tank contents and its surroundings, and the low latent heat of vaporization of hydrogen combine to produce an unsatisfactorily high evaporation rate for the LH<sub>2</sub> for all but the highest quality insulation systems. For this reason, the frozen-earth type of underground storage tank which has been used for liquefied natural gas (LNG) storage would not be suitable. Other than the excessive loss of LH<sub>2</sub> resulting from cooldown of the surrounding earth, liquefaction and freezing of air from the surroundings will also occur as it diffuses through the ground toward the cold vessel wall. This presents a safety hazard as rectification of the air will tend to occur, with preferential vaporization of the more volatile nitrogen and concentration of oxygen in the residual liquid. The oxygen-enriched liquid upon encounter with combustible material will be potentially explosive. An acceptable insulation system must therefore include an impervious barrier to the diffusion of air toward the wall of the liquid container.

The only satisfactory underground tank, therefore, would be a double-wall vacuum insulated tank. The advantage in locating this tank underground is only to lower the tank profile or to remove it entirely as an obstruction to flight traffic. This should only be done as required; if specified clearances can be maintained with aboveground tanks, there is economic advantage in aboveground installation.

### 4.3.3 Vacuum insulated double wall tanks

4.3.3.1 Powder insulation. - This tank configuration consists of a cold inner liquid container, a warm outer container, and an evacuated annulus which is filled with a powder insulation, typically perlite. The shape is usually spherical which gives a minimum surface area per unit of contents and helps to minimize heat leakage. This design is the commercially accepted standard in the liquid hydrogen industry and is hereby recommended for use in this study.

Tank specifications are listed in Table XV. Materials of construction would be typically carbon steel for the warm shell and austenitic stainless steel for the liquid container. Vacuum in the insulation space is maintained at 13.30 Pa (100 microns) or less which results in an effective thermal conductivity of no greater than 2.6 W/m-K ( $1.5 \times 10^{-3}$  Btu/hr-ft-R). The resulting net evaporation rate is 0.06% of tank contents per day or  $1.86 \times 10^{-3}$  kg/s (354 lb/day) for the 3785 m<sup>3</sup> (1 000 000 gal) tank.

4.3.3.2 Multilayer insulation. - This tank configuration is the same as that for the powder insulation except that the powder is replaced by a multilayer insulation consisting of alternate layers of low emissivity metal foil (usually aluminum) and a thin, low conductance spacer (usually glass fiber paper). The vacuum integrity required of the two vessels must be of higher order than those used with vacuum perlite insulation due to the greater sensitivity of the multilayer thermal conductivity to pressure. A vacuum of 0.0133-0.266 Pa (0.1-2.0 microns) must be maintained.

TABLE XV SPECIFICATIONS: LIQUID HYDROGEN STORAGE TANK VACUUM POWDER INSULATION

	SI	Customary
Capacity	3 785 m <sup>3</sup> 267 600 kg	(1 000 000 gallons) (590 000 lbs)
Working pressure	205 kPa	(15 psig)
Outer tank O.D.	21.6 m	(71 ft)
Inner tank O.D.	20.1 m	(66 ft)
Net evaporation rate	0.06% per day	
Insulation	Vacuum perlite	
Configuration	Spherical	

The specifications for this type of tank are listed in Table XVI. The net evaporation rate at the optimized 24.1 cm (9.5 in) insulation thickness amounts to 0.028% per day which is about half that for the vacuum perlite insulation. The resulting hydrogen loss amounts to  $8.77 \times 10^{-4}$  kg/s (167 lb/day).

The tank is field erected and the insulation is installed afterward so that the outer shell provides protection against the weather. The 0.762 m (2.5 ft) wide annulus between the inner tank and outer shell provides enough room for workmen to apply sheets of the multilayer insulation to the outer surface of the inner tank. Access to the insulation space is provided by a manway in the outer shell which is sealed with a welded-on cover after installation is complete. This insulation system was rejected in the final selection for economic reasons and because of the sensitivity of its thermal performance to slight changes in vacuum.

4.3.4 Insulated single wall tanks. - Single wall tanks always present the designer with the attraction that the outer shell, and its attendant cost, is eliminated. The simplification, however, makes a high level of thermal performance more difficult to achieve because there is no simple way to apply a vacuum insulation. Consequently, enhanced performance must be achieved by an increase in insulation thickness.

The insulation applied to a tank in liquid hydrogen service presents the additional problem of excluding air from the insulation. As described in the section on underground tankage, unless a completely impervious coating is

TABLE XVI SPECIFICATIONS: LIQUID HYDROGEN STORAGE TANK MULTILAYER INSULATION

	SI	Customary
Capacity	3 785 m <sup>3</sup> 267 600 kg	(1 000 000 gallons) (590 000 lb)
Working pressure	205 kPa	(15 psig)
Outer tank O.D.	21.6 m	(71 ft)
Inner tank O.D.	20.1 m	(66 ft)
Insulation thickness	24.1 cm	(9.5 in.)
Net evaporation rate	0.028% per day	
Insulation	Vacuum multilayer	
Configuration	Spherical	



applied to the surface, air will diffuse through the insulation space toward the cold tank wall, condensing and freezing as the temperature decreases to that of LH<sub>2</sub>. Not only will the thermal conductivity of the insulation system be compromised by such action but also the physical integrity will be destroyed. The structure of closed-cell foams, for example, will be damaged and if sufficient frozen air accumulates at the tank wall, sections of insulation can be blown off, even violently, upon tank warm up as the frozen air vaporizes.

Mindful of the preceding advantage and limitations, a single wall tank is examined (Table XVII) which features a sprayed-on polyurethane foam insulation. This material has a thermal conductivity of 0.012 W/m-K (0.007 Btu/hr-ft-R) at a density of 40 kg/m<sup>3</sup> (2.5 lb/ft<sup>3</sup>). A thickness of 1.07 m (3.5 ft) provides near-optimum performance. Wire mesh reinforcement is assumed to be required for every 0.305 m (1 ft) of insulation thickness for structural strength. A vapor barrier of butyl rubber is applied to the outer surface topped off with a noncombustible layer for fireproofing. This insulation is assumed to have a useful life of 10 years, which may be optimistic. At such time, the insulation must be removed and replaced. This type of insulation system was rejected in the final selection for economic reasons and because of unproven performance.

4.3.5 Economic comparison. - An economic comparison was made between the vacuum perlite, the multilayer, and the single wall insulation systems on a present value basis which includes tank investment and cost of evaporation loss as cost elements. Evaluation of the evaporation cost is based on locating the storage tanks at the airport site and that the evaporated hydrogen is recoverable for reliquefaction. Therefore, only the cost of liquefaction, at a unit value of 42.0¢/kg (19.05¢/lb) of hydrogen, was incurred. (Ref. 7)

TABLE XVII. SPECIFICATIONS: LIQUID HYDROGEN STORAGE  
TANK SINGLE WALL - FOAM INSULATION

	SI	Customary
Capacity	3 785 m <sup>3</sup> 267 600 kg	(1 000 000 gallons) (590 000 lb)
Working pressure	205 kPa	(15 psig)
Inner tank O.D.	20.1 m	(66 ft)
Insulation thickness	1.07 m	(3.5 ft)
Net evaporation rate	0.344% per day	
Insulation	Polyurethane foam	
Configuration	Spherical	

Capital investment for vacuum perlite insulated spherical liquid hydrogen storage tanks, including installation, is shown on Figure 18. The cost capacity curve is seen to be linear with a slope of \$1055 per  $m^3$  (\$4/gal) of capacity. A 3785  $m^3$  (1 000 000 gal) storage tank will cost \$4 000 000. This is the largest capacity tank which has been built for  $LH_2$  service. Because of the absence of economic advantage with increasing capacity, there is considerable freedom to select the number and size of the storage tanks based on other factors. A maximum capacity tank will result in the lowest evaporation loss per unit of capacity, the least site area and the minimum complexity in pumping and manifolding the storage tanks to the fueling circuit. Considerations of site limitations, backup requirements and the need for at least three separate tanks for fueling operations lead to the selection of the 3785  $m^3$  (1 000 000 gal) capacity tank for use at the SFO site.

Table XVIII and Figure 19 both present an economic comparison between the three types of insulation systems for the 3785  $m^3$  (1 000 000 gal) tank. As expected, the single wall foam-insulated tank has the lowest investment and the multilayer-insulated tank has the highest. The converse is true of the annual evaporation cost. A sizeable expense is incurred for the replacement of the foam insulation, half of it occurring after 10 years and the other half after 20 years. This is assumed to be an operating expense. The present value of the replacement cost is quite low, however, because the expense is incurred so far in the future. It is the experience of the cryogenics industry that maintenance cost on double wall, vacuum insulated tanks is essentially nil.

The economic choice is the vacuum perlite insulation system which exhibits 3 percent advantage over the single wall tank and a 7 percent advantage over the multilayer system. The multilayer-insulated tank is the only serious contender to the vacuum perlite insulated tank as a proven system. The single wall tank cannot be seriously considered as a viable alternate at this time because the performance and physical integrity of its foam insulation system has not been proven, the factors assumed herein being somewhat conjectural. The vacuum perlite insulation has a lower initial investment than the multilayer type; however, the thermal performance is not nearly as good, resulting in a more-than-double evaporation cost. This advantage of the multilayer system would disappear with a slight loss of vacuum because of the sensitivity of this system to pressure. An increase to 1.33 Pa (10 microns) of pressure could more than dissipate the thermal advantage of the multilayer insulation over the vacuum perlite. For reasons of proven performance, simplicity, reliability and cost, the vacuum perlite insulation system selected for use in this analysis of airport requirements.

#### 4.4 Task 6: Hydrogen Liquefaction

Task 3 (Section 4.1) results clearly showed the economic advantage of locating the liquefaction facility at the airport site. Such location is contingent, of course, upon the availability of the necessary land area at the airport. This task addresses itself to that question. Plant layouts are developed for a central liquefaction complex large enough to supply the liquid

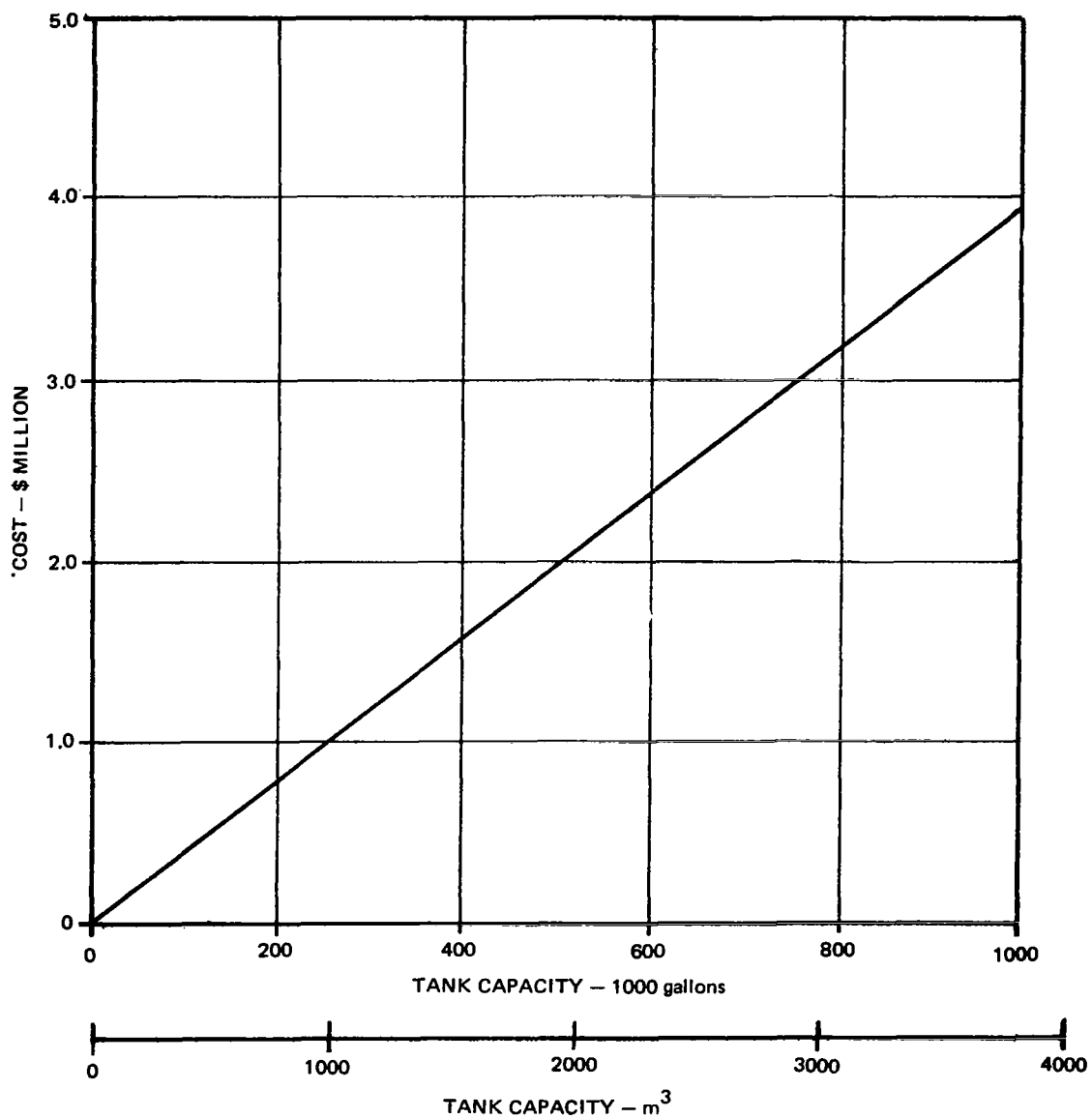

Figure 18. Cost of Spherical Double Wall Vacuum Perlite Insulated Liquid Hydrogen Storage Tanks

TABLE XVIII. ECONOMIC COMPARISON LIQUID HYDROGEN STORAGE TANKS

Capacity = 3785 m<sup>3</sup> (1 000 000 gal)

	Insulation System		
	Vacuum Perlite	Vacuum Multilayer	Single Wall Foam
Investment	\$4 000 000	\$4 387 000	\$3 553 000
Evaporation rate, kg/s	1.86 x 10 <sup>-3</sup>	8.77 x 10 <sup>-4</sup>	1.07 x 10 <sup>-2</sup>
Annual evaporation cost	\$ 24 610	\$ 11 610	\$ 141 000
Insulation replacement	- - - - -	- - - - -	\$ 625 000
Present value			
Investment	\$3 838 000	\$4 210 000	\$3 409 000
Evaporation cost	\$ 103 000	\$ 49 000	\$ 591 000
Insulation Replacement	<u>- - - - -</u>	<u>- - - - -</u>	<u>\$ 69 000</u>
Total	\$3 941 000	\$4 259 000	\$4 069 000

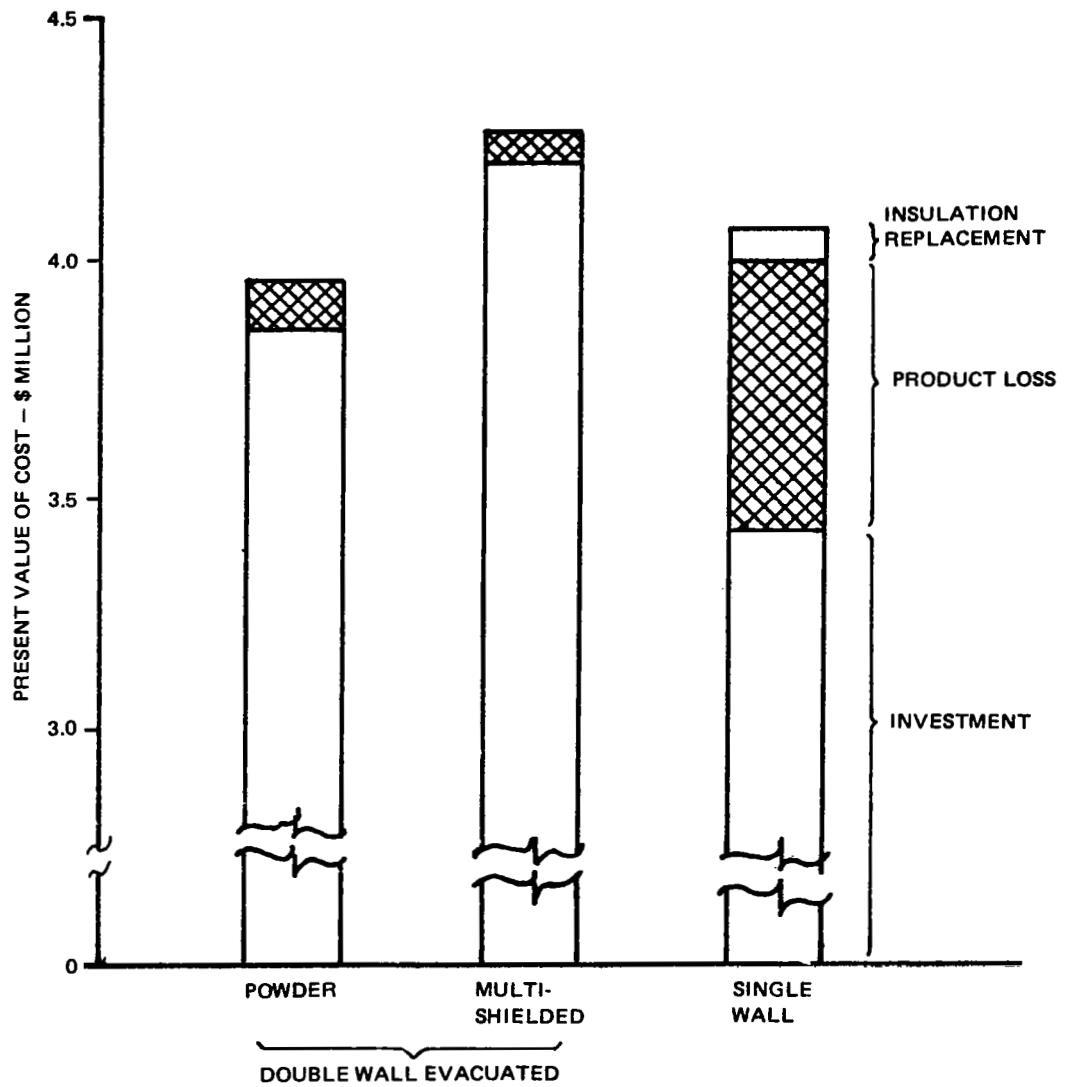

Figure 19. Cost of Three Types of Liquid Hydrogen Storage Tanks

hydrogen requirements as determined in Tasks 2 and 3 and also for a single-module liquefier for capacity expansion purposes. In addition, necessary siting arrangements and construction practices for safe installation and operation of the liquefaction plant are considered and presented.

4.4.1 Liquefaction facility requirements. - Establishing the capacity of the liquefaction facility was the first task faced. The facility must be sufficiently large to provide not only for the block fuel requirements to the engines but also for the losses incurred in fueling operations as described in Task 7. Sufficient capacity must also be provided to meet the needs of peak-month operations. Peak requirements are expected to increase about 37 percent over average capacity during off-peak month operation in the year 2000 (Task 2).

Task 2 places peak month block fuel requirements at 7.68 kg/s (731.4 tons/day). Loss analysis presented in Task 3 predicts a 12.2 percent loss in refueling operations and a 3.2 percent loss for the more optimistic method of tank operations, giving a combined loss of 15.7 percent between LH<sub>2</sub> in storage to LH<sub>2</sub> delivered as fuel to the engines, including the loss due to boiloff in the aircraft tanks. Liquefaction capacity during peak months must, therefore, be 8.886 kg/s (846.2 tons/day).

It has been shown (Reference 7) that the largest hydrogen liquefaction module that can be economically justified has a capacity of 2.625 kg/s (250 tons/day). Therefore, it was decided the liquefaction facility at SFO would use four production modules of this capacity. This provides for a maximum output of 10.5 kg/sec (1000 tons/day) which is 18 percent in excess of peak demand and 62 percent in excess of average demand during off-peak operations. These requirements are, however, based on fueling losses from the optimum method of tank operations (Method #1 from Task 3). Based on the least efficient method of tank operations (Method #2), liquefaction requirements are 9.483 kg/s (903.2 tons/day) for peak month operation and 6.912 kg/s (658.3 tons/day) for average off-peak operation. The four liquefaction modules therefore provide a 10.7 percent margin in production capacity over the maximum conceivable demand situation.

4.4.2 Liquefaction facility description. - The 10.5 kg/sec (1000 tons/day) total liquefaction capacity is provided by four identical modular units. Figure 20 is a schematic diagram which illustrates the flow of the liquefaction process. A plot plan which shows the equipment arrangement is presented in Figure 21.

Impure gaseous hydrogen feedstock, having a hydrogen purity of about 96.6 percent and containing nitrogen, carbon monoxide, carbon dioxide, and methane as impurities, is distributed from the feedstock pipeline to the first stage of the four reciprocating hydrogen feed compressors. The feedrate required to produce the 8.888 kg/s (846.5 tons/day) peak month LH<sub>2</sub> product rate is 453 100 m<sup>3</sup>/h (16.0x10<sup>6</sup> SCFH). The compressed gas is then purified cryogenically to yield an extremely pure hydrogen gas which is then boosted to 4137 kPa (600 psia) in the second stage of the hydrogen feed compressors

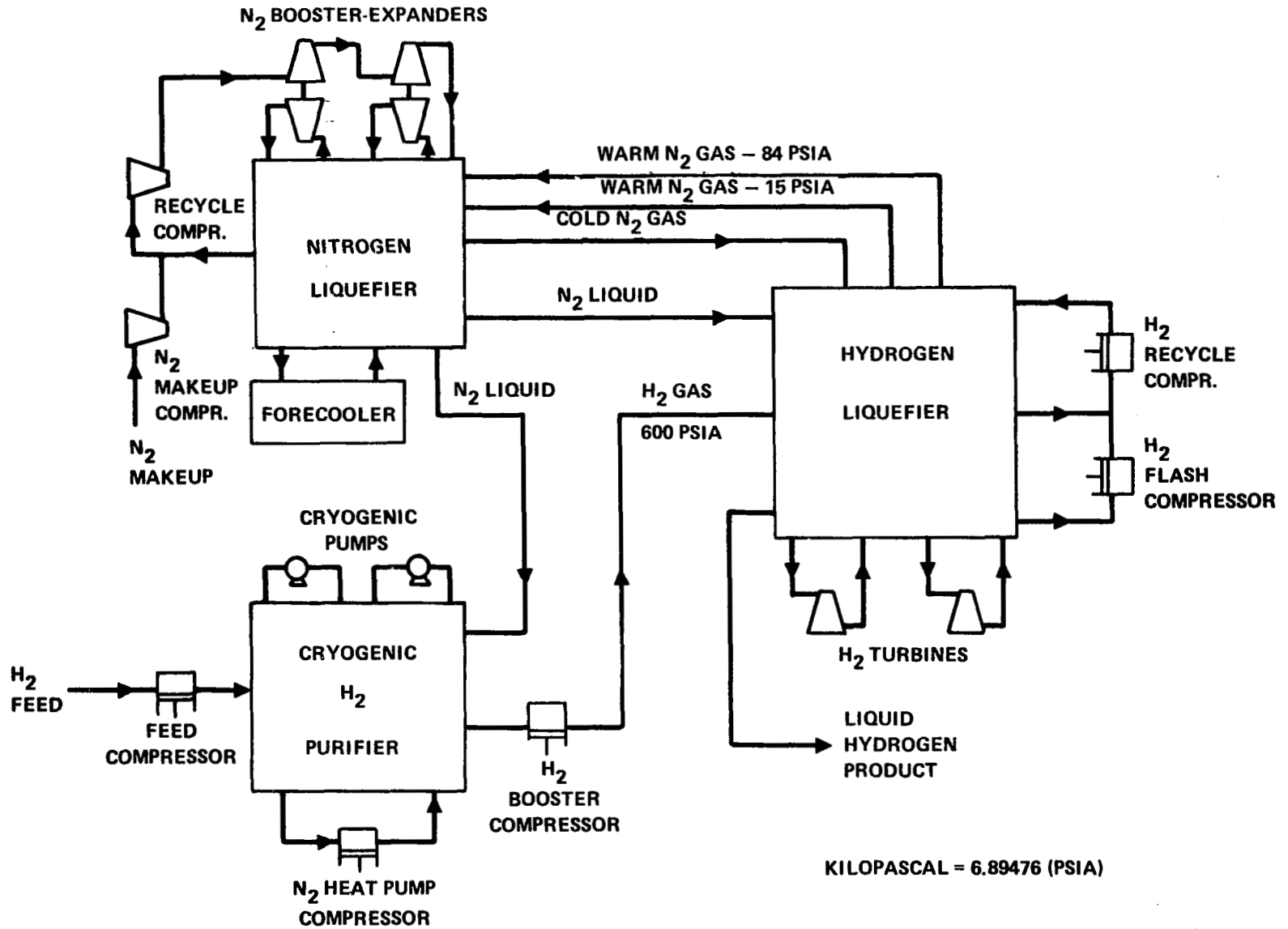

Figure 20. Block Diagram - Liquefaction Process

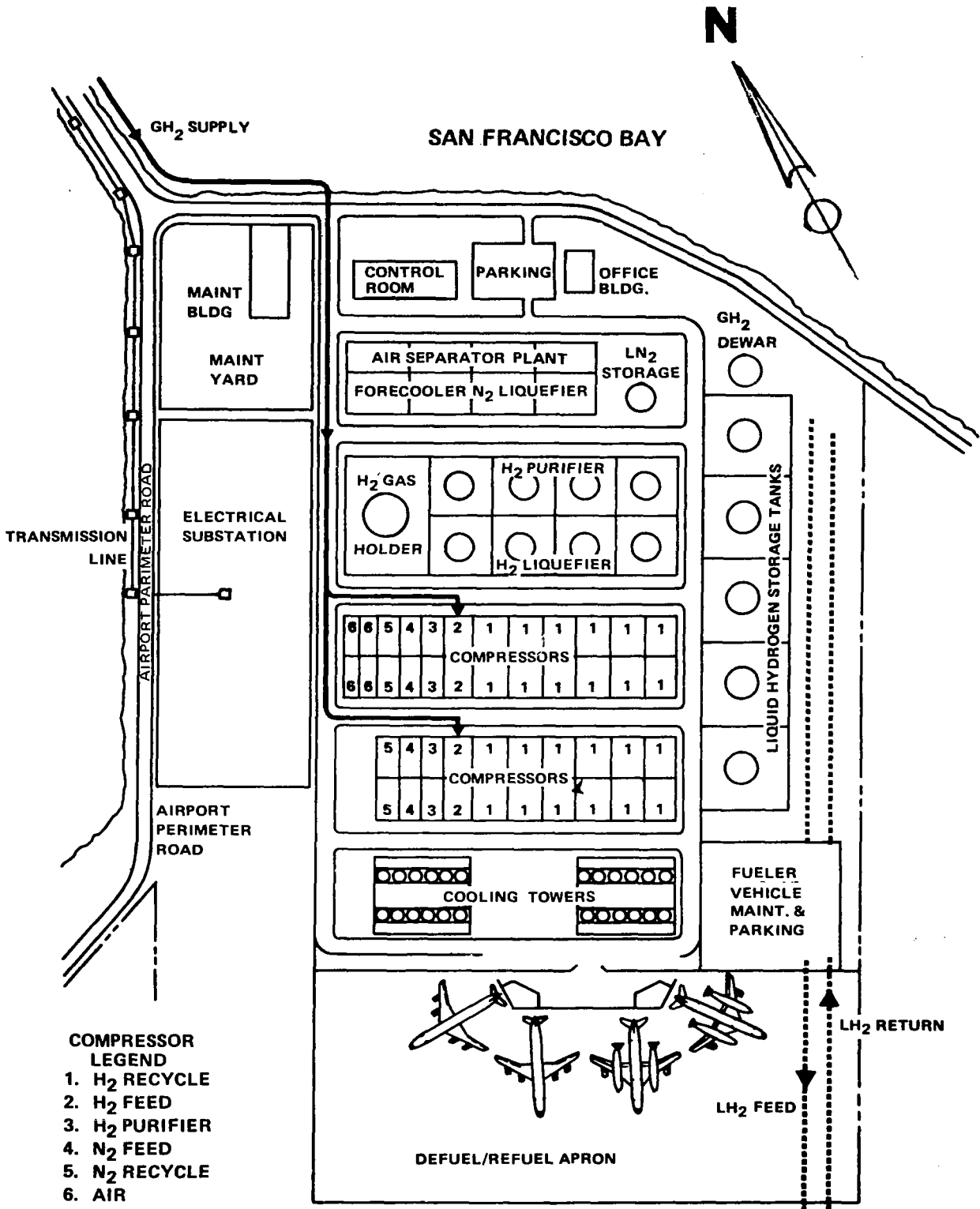

Figure 21. Proposed Hydrogen Liquefaction/Storage Facility San Francisco International Airport



for delivery to the hydrogen liquefier cold boxes. In the liquefier, the hydrogen is not only liquefied but also converted to about 60 percent para H<sub>2</sub> for normal operations or 97 percent para for H<sub>2</sub> which is delivered to the storage tanks for long term storage.

Refrigeration for the liquefaction of the hydrogen is supplied by two different methods. For temperature levels down to 80 K, liquid nitrogen and cold nitrogen gas are transferred from the nitrogen refrigerator cold boxes to the hydrogen liquefier cold boxes. To meet refrigeration requirements at colder temperature levels, a recycle stream of compressed hydrogen is expanded in a set of cryogenic hydrogen turbines, each liquefier cold box having a set of turbines attached. The turbines are loaded with electrical generators to permit work recovery and the generator output is fed back into the plant electrical supply system. The expanded recycle hydrogen stream, after warming, is returned to suction of the hydrogen recycle compressors. There are 24 of these reciprocating machines, each rated at 8 553 kW (11 466 bhp), which are used to return the pressure of the recycle stream to 4137 kPa (600 psia).

The nitrogen refrigerator supplies refrigeration at the 80 K temperature level to both the hydrogen liquefier and the hydrogen purifier via the liquid nitrogen and cold nitrogen gas streams. The warmed nitrogen gas streams from which the refrigeration has been extracted are recycled to the nitrogen refrigerator. Some of them are at atmospheric pressure and the remainder at the suction pressure of the nitrogen recycle compressor. The low pressure portion is distributed to the four 2535 kW (3400 bhp) centrifugal nitrogen feed compressors for compression to the recycle compressor suction pressure. Both fractions now combine with the main nitrogen recycle stream which is boosted to 4137 kPa (600 psia) in the four 20 834 kW (27 926 bhp) nitrogen recycle compressors followed by pairs of booster compressors. These booster compressors are connected to the shafts of the nitrogen centrifugal turbines and absorb their work output. Each of the four nitrogen refrigerator cold boxes has an associated pair of turbines for the purpose of providing refrigeration at temperature levels below 235 K. For higher temperature levels, refrigeration is supplied by four 3459 kW (983 ton) forecooling units which employ a commercial fluorocarbon refrigerant as the working fluid. The expanded nitrogen which exhausts from turbines is warmed for refrigeration recovery and recycled to the suction of the nitrogen recycle compressors.

Four air separation plants are provided for make-up of nitrogen gas which is lost via leakage from compressors, turbines, valves, flanges, etc. Each plant is designed to produce only nitrogen at a rate of 8,496 m<sup>3</sup>/h (300 000 SCFH) and at the suction pressure of the nitrogen recycle compressor, so that the make-up gas can be added directly to the recycle stream. Four 1491 kW (2000 bhp) centrifugal air compressors are used to supply 21 240 m<sup>3</sup>/h (750 000 SCFH) of air to each cold box. Each air separation plant is self-refrigerating with its own expansion turbine so that a supply of nitrogen is assured for startup of the nitrogen refrigerator.

The hydrogen purifier is of the cryogenic absorption type, which features liquid methane and liquid propane scrubbers to achieve the purification. Each of the four purifier cold boxes has an associated centrifugal compressor rated at 3169 kW (4250 bhp) for the purpose of recompressing an internal nitrogen stream.

The liquid nitrogen storage tank provides back-up amounting to  $2.124 \times 10^6 \text{ m}^3$  ( $75 \times 10^6$  SCF) which is sufficient for one-day's outage of one nitrogen refrigerator. Multiple outages are considered to be rare occurrences and one day's backup should be adequate.

The hydrogen gas holder is for the purpose of providing surge capacity at the suction of the hydrogen recycle compressors and floats on the low pressure recycle return line. The one gas holder serves all 24 recycle compressors.

The liquid hydrogen product from each of the four hydrogen liquifiers feeds into a supply line of vacuum jacketed pipe which, in turn, feeds each of the five liquid hydrogen storage tanks. Two of the tanks will be maintained full of liquid hydrogen at all times. The other three tanks will be used in fueling operations, one dispensing fuel, one receiving fuel from production and from loop return, and one filled with  $\text{LH}_2$  in ready standby for transfer to dispensing service. Thus, there will be an amount of liquid hydrogen equal to at least one day's requirement in storage at all times. Three full tanks will contain 803 675 kg (885.9 tons) of fuel which will provide 25.1 hr of backup during peak month operation or 34.5 hr of backup during off-peak operation.

At a peak month production rate of 8.888 kg/s (846.5 tons/day), a tank fill will be accomplished in about 8.4 hours. During periods of maximum fueling, where four aircraft are being fueled simultaneously, the  $\text{LH}_2$  dispensing rate can be as great as  $0.7318 \text{ m}^3/\text{s}$  (11 600 gal/min) which, if continued, would deplete the tank in only 1.44 hour. However, the SFO fueling schedule shows this peak fueling rate to exist for only a short period of time. Over the busy morning schedule, approximately 8 hours will be required to empty the tank. Coordinating filling and dispensing operations will not be a difficult problem because, over an 8 hour period of time, the production and consumption rates are quite similar.

Table XIX lists the equipment required for the four-module liquefaction facility. The cryogenic equipment for the hydrogen purifier, the hydrogen liquefier, the nitrogen refrigerator and the air separation plant is each installed in a separate cold box. Reciprocating compressors are required for hydrogen compression. The 8553 kW (11 466 hp)  $\text{H}_2$  recycle compressor is almost the largest size commercially available at the present time. All other compression requirements can be met with centrifugal compressors. Electric motors are used to drive all compression equipment.

TABLE XIX. EQUIPMENT LIST OF MAJOR ITEMS:  
 HYDROGEN LIQUEFACTION/STORAGE COMPLEX  
 SAN FRANCISCO INTERNATIONAL AIRPORT

<u>Item</u>	<u>No.</u>	<u>Description</u>
1	4	H <sub>2</sub> Liquefier Cold Box, 2.625 kg/s (250 t/d), LH <sub>2</sub> capacity, 22.86 m dia x 18.29 m h (75 ft x 60 ft)
2	4	H <sub>2</sub> Purifier Cold Box, 2.625 kg/s (250 t/d) LH <sub>2</sub> capacity, 19.81 m dia x 18.29 m h (65 ft x 60 ft)
3	4	N <sub>2</sub> Refrigerator Cold Box, 2.625 kg/s (250 t/d) LH <sub>2</sub> capacity, 9.14 m dia x 10.67 m h (30 ft x 35 ft)
4	4	Air Separation Plant Cold Box, 8496 m <sup>3</sup> /hr (3000 000 cfh) N <sub>2</sub> gas capacity, 3.66 m dia x 12.12 m h (12 ft x 40 ft)
5	4	Forecooling Refrigeration Units, 3459 kW (983 tons) refrigeration capacity, 9.144 m x 7.62 m x 3.05 m h (30 ft x 25 ft x 10 ft)
6	5	LH <sub>2</sub> Storage Tanks, spherical, 3785 m <sup>3</sup> (1 000 000 gal) capacity, 21.64 m dia x 25.91 m overall height (71 ft x 85 ft)
7	1	LN <sub>2</sub> Storage Tank, cylindrical, 2460 m <sup>3</sup> (650 000 gal) capacity, 19.58 m dia x 16.66 m h (64.25 ft x 54.67 ft)
8	1	H <sub>2</sub> Gas Holder, 5664 m <sup>3</sup> (200 000 cf) capacity, 27.43 m dia x 19.20 m h (90 ft x 63 ft)
9	1	Electrical Substation and Switchgear Center, 350 000 kW, 91.44 m x 236.2 m (300 ft x 775 ft)
10	4	Cooling Towers, 10 788 m <sup>3</sup> /s (47 500 gpm), 25.0 m x 53.3 m x 18.3 m h (82 ft x 175 ft x 60 ft)
11	24	H <sub>2</sub> Reciprocating Recycle Compressors, 8553 kW (11 466 bhp) 21.34 m x 26.67 m x 3.05 m h (70 ft x 87.5 ft x 10 ft)
12	4	H <sub>2</sub> Reciprocating Feed-Booster Compressor, 5404 kW (7250 bhp) 18.29 m x 26.67 m x 2.44 m h (60 ft x 87.5 ft x 8 ft)
13	4	N <sub>2</sub> Centrifugal Recycle Compressor, 20 834 kW (27 926 bhp) 15.24 m x 26.67 m x 3.20 m h (50 ft x 87.5 ft x 10.5 ft)

TABLE XIX. - Concluded

<u>Item</u>	<u>No.</u>	<u>Description</u>
14	4	Purifier Centrifugal Compressor, 3166 kW (4250 bhp) 3.05 m x 9.14 m x 2.44 m h (10 ft x 30 ft x 8 ft)
15	4	N <sub>2</sub> Centrifugal Feed Compressor, 2536 kW (3400 bhp) 3.05 m x 9.14 m x 2.44 m h (10 ft x 30 ft x 8 ft)
16	4	Air Plant Centrifugal Compressor, 1492 kW (2000 bhp) 3.05 m x 7.62 m x 2.44 m h (10 ft x 25 ft x 8 ft)
17	1	Maintenance Building, 1393.5 m <sup>2</sup> (15 000 ft <sup>2</sup> ), 22.86 m x 60.96 m x 7.62 m h (75 ft x 200 ft x 25 ft)
18	1	Control Room, 1393.5 m <sup>2</sup> (15 000 ft <sup>2</sup> ), 22.86 m x 60.96 m x 4.57 m h (75 ft x 200 ft x 15 ft)
19	1	Office Building, 501.7 m <sup>2</sup> (5400 ft <sup>2</sup> ), 18.29 m x 27.43 m x 4.57 m h (60 ft x 90 ft x 15 ft)

4.4.3 Layout of liquefaction facility. - A plot of land northwest of the existing site of the American Airlines Hangar and bordering on the seaplane harbor is assumed to be available for installation of the liquefaction equipment and storage tanks. As shown in Figure 21, this site is also the location of the defuel/refuel apron and the two defuel/refuel stands. The following guidelines were given consideration in the location of the equipment.

- a. There is merit in locating items of equipment associated with the greatest quantities of LH<sub>2</sub> at the greatest distance from field activities for mutual protection. Thus the hydrogen liquefaction cold boxes are located about 610 m (2000 ft) from the nearest runway and about 457 m (1500 ft) from the nearest taxiway. The LH<sub>2</sub> storage tanks are situated along the east property line to permit a reduction in the length of piping in the refueling line although it does result in some relaxation of this guideline. Nevertheless, the nearest tank is 221 m (725 ft) from the nearest taxiway and 373 m (1225 ft) from the nearest runway while the corresponding distances to the farthest tank are 434 m (1425 ft) and 587 m (1925 ft) respectively. These distances do not conflict with the requirements of guideline i, following.
- b. The defueling stands must provide direct access to the taxi strip.
- c. The various items of equipment must be located in a logical relationship to one another from a process standpoint.
- d. Adequate access must be provided to all pieces of equipment.
- e. Adequate space must be provided around each item of equipment for maintenance, repair and disassembly.
- f. Adequate egress routes must be provided in case of fire or other emergency.
- g. Diking of the storage tanks is used. Although catastrophic failure of the tank is a remote possibility, the consequence of a massive release of LH<sub>2</sub> onto an unconfined surface would be to risk an expansion of any fire which would result.
- h. Minimum clearance distances for location of equipment is in compliance with the recommendations of Section B1, Appendix B of this report.
- i. Equipment must be located at a sufficient distance from the runway to comply with standard FAR Part 77 concerning clearances for air traffic.

The irregular area shown in Figure 21 amounts to 254,135 m<sup>2</sup> (62.8 acres). Its overall dimensions of 433 m (1420 ft) x 645 m (2125 ft) exceed the available amount of land by about 45 percent. Additional area to meet requirements is

obtained by a 81000 m<sup>2</sup> (20 acres) landfill of the seaplane harbor along the north shore of the site. The layout also requires some intrusion into the hangar area along the west property line but the hangar itself need not be touched. A causeway is installed across the seaplane harbor to the north corner of the site to bring in the electrical power lines and the 0.76 m pipeline for the gaseous hydrogen feed. Creation of this corridor for utility supply appeared to be the approach which would be least disruptive to airport operations.

The layout presented herein is not the only possible arrangement of individual equipment pieces in the total complex and is probably not even the optimum arrangement. Additional study would almost certainly result in an improved layout but layout optimization is outside the scope of this work. The study does reveal that a central liquefaction complex can be located at the San Francisco International airport and does provide information concerning total land requirements.

4.4.4 Single module liquefaction layout. - A plant layout for a single module liquefaction unit to supply 2.625 kg/s (250 tons/day) of liquid hydrogen product is presented in Figure 22. Preparation of this layout is for the purpose of determining site requirements in the event of future expansion of air traffic for the LH<sub>2</sub> - fueled aircraft. The layout is completely general so that no limitations are imposed with respect to site location. Two possible locations can be suggested, however: One would be on land created by additional landfill in the seaplane harbor; the other would be an off-site location with LH<sub>2</sub> piped in via vacuum jacketed pipeline, as per Task 3.

One liquid hydrogen storage tank of 3218 m<sup>3</sup> (850 000 gal) capacity is included to provide one day's backup capacity. Only a single tank is used because it would not be used in the fueling operations. The output of the liquefier would be piped directly to the existing tank farm for day-to-day operation. Site requirements would be approximately 60,800 m<sup>2</sup> (15 acres).

4.4.5 Safety considerations. - A discussion of safety aspects relative to distance standards, i.e., location of equipment and facilities, separation between storage units, concentrations of people, etc; materials of construction; ventilation requirements; electrical system protection; gas disposal systems; and fire protection for hydrogen facilities is presented in Appendix B. The design of the liquefaction plant and storage vessels for SFO is arranged with these standards as a guide.

4.4.6 Gaseous hydrogen vent collection system. - The quantity of hydrogen evolved during maximum fueling operations is quite large and can amount to as much as 21.63 m<sup>3</sup>/s\* (2 750 000 ft<sup>3</sup>/hr). This hydrogen gas is also quite cold and, therefore, not only the value of the hydrogen itself is involved but also the value of the refrigeration which it possesses. The generation of hydrogen gas from coal will cost 36.27¢/kg (16.45¢/lb), so that the total amount of hydrogen gas with which we are concerned has an annual value of at least \$20.7 million and a present value of at least \$86.5 million. The value of the

---

\*Measured at 101.325 kPa (1 atm) and 294.3 K (70°F)

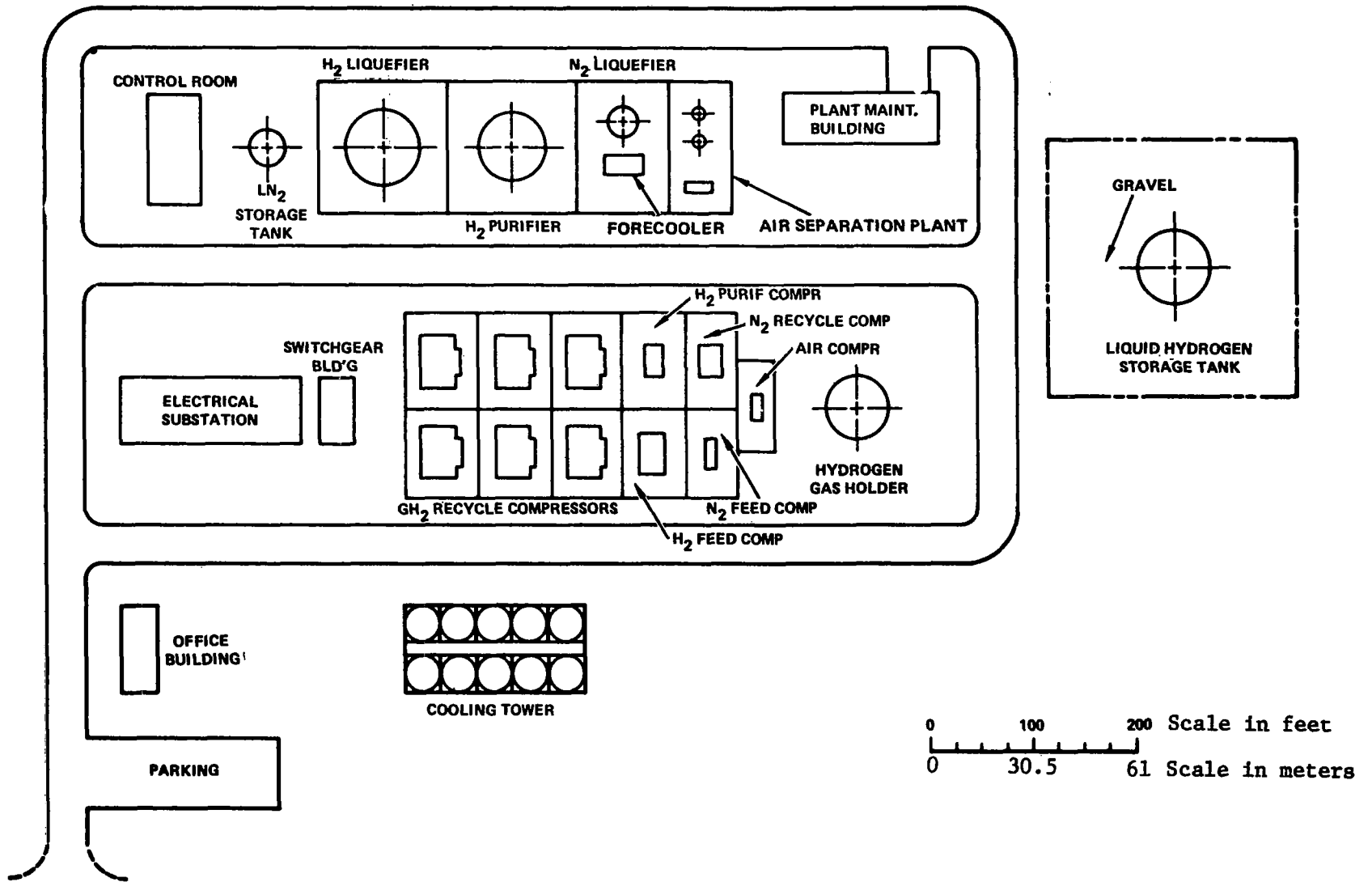

Figure 22. Plant Layout 250 TPD (2.625 kg/s) Hydrogen Liquefaction Module

refrigeration content of the cold gas, assumed to amount to 8.42¢/kg (3.82¢/lb) at 3¢/kW, adds another \$4.8 million annually which is equivalent to a present value of \$20.1 million. An investment of up to \$107 million can therefore be justifiably expended in the recovery of this cold hydrogen gas. Because recovery of the cold GH<sub>2</sub> is so cost effective the cost analysis presented in Section 5.1.2.3 is based on the assumption that all gaseous hydrogen bailed-off in ground operations at the airport is recovered and reliquefied.

4.4.7 Utilities. - Utilities for servicing the liquefaction complex when operating at 8.92 kg/s (850 tons/day) capacity are listed in Table XX. For other production rates, proportionality between utility consumption and production rate is a reasonable assumption.

Utility requirements are based on the assumption of successful completion of the development program cited in Ref. 7 and would be representative of technology in the year 2000. The development program includes improvement in compressor and expander efficiency, partial ortho-para conversion to 60 percent para), leakage reduction recovery of hydrogen from purifier tail gas.

Electricity is the major utility required and amounts to 331 800 kW. This translates to a unit power consumption of 10.33 kWh/kg (4.68 kWh/lb) of liquid hydrogen produced.

4.4.8 Costs. - Investment and operating costs and cost assumptions for the liquefaction/storage complex are presented in Tables XXI, XXII, and XXIII respectively. These data permit the unit cost for the LH<sub>2</sub> to be determined as subsequently described in Section 5.1.

4.4.9 Personnel requirements. - Total manpower requirements for operating and maintaining the liquefaction/storage facility total 103 persons. This breaks down into four operating crews of 13 men each plus four maintenance crews of 7 men each. One foreman will also be required for each of the four shifts. This totals 84 persons or 21 persons per shift. In addition, ten office personnel, two foremen supervisors, a quality control analyst, two instrument technicians, two plant engineers, a plant superintendent and an assistant are required. This personnel complement is that required for operation of the liquefaction facility and does not include personnel required for aircraft fueling operations.

#### 4.5 Task 7: Airport Fuel Distribution System

The object of this task was to identify feasible equipment and procedures for the LH<sub>2</sub> distribution and fueling system. Such identification is considered elemental to the study in that it will provide a basis for assessment of the problems and requirements of handling LH<sub>2</sub>-fueled aircraft at a designated airport (SFO) which, of course, is the primary objective of this study.

The LH<sub>2</sub> fueling system is viewed as consisting of the aircraft fuel system, the ground distribution system (between storage and hydrant), and the fueling equipment/procedures that provide the necessary interface between the



TABLE XX. UTILITY SUMMARY: HYDROGEN LIQUEFACTION/STORAGE  
 COMPLEX, SAN FRANCISCO INTERNATIONAL AIRPORT

For 8.925 kg/s (850 tons/day)

Electrical Power - kW

Production

Hydrogen compressors	176 720
Nitrogen recycle compressors	73 010
Forecooler	9 220
Air compressor, N <sub>2</sub> plant	4 440
Purifier heat pump compressor	9 310
Hydrogen feed/booster compressor	15 680
Nitrogen feed compressor	7 440
Hydrogen drier	2 310
Pumps	575
	<hr/>
Subtotal	298 705
Hydrogen turbine return	- 8 870
	<hr/>
Net Subtotal	289 925

Production Auxiliaries

Cooling tower and water supply	13 790
Plant air compressor and drier	875
Purge blower and thaw heater	4 270
Miscellaneous	5 670
	<hr/>
Subtotal	24 605
Process Contingency (5%)	15 770
	<hr/>
Subtotal	330 300

Plant Auxiliaries

Road and exterior lighting	300
Building lighting, heating, air conditioning	750
Cranes	250
	<hr/>
	1 300

TABLE XX. - Concluded

Total Brought Forward			331 600
Fueling Pumps (avg)			<u>200</u>
	Total, Electrical Power		331 800
<u>Water</u>			
Cooling water makeup	- m <sup>3</sup> /s (gpm)	0.265	(4 200)
Potable water	- m <sup>3</sup> /s (gal/day)	0.001 095	(25 000)
<u>Chemicals</u>			
Sulfuric acid for water treatment	- kg/hr (lb/hr)	504	(1 110)
Desiccants and adsorbents	- kg/hr (lb/hr)	63 000	(139 000)
<u>Heating Fuel</u>			
For annual plant thaw	kJ (Btu)	7.17 x 10 <sup>8</sup>	(6.8 x 10 <sup>8</sup> )

TABLE XXI. CAPITAL INVESTMENT: HYDROGEN LIQUEFACTION/STORAGE COMPLEX,  
SAN FRANCISCO INTERNATIONAL AIRPORT

10.5 kg/s (1000 tons/day)

Total plant investment	\$239 000 000
Interest during construction (1)	53 800 000
Startup costs	6 570 000
Working capital (2)	9 250 000
	<hr/>
Total capital requirement	\$308 620 000

(1) At 12 percent interest rate on total plant investment for 1.875 years.

(2) Sum of (1) materials and supplies at 0.9 percent of total plant investment plus (2) net receivables on product hydrogen at 1/24 of annual production at 80.82 ¢/kg (36.66 ¢/lb).

TABLE XXII. ANNUAL OPERATING COST: HYDROGEN LIQUEFACTION/STORAGE  
 COMPLEX, SAN FRANCISCO INTERNATIONAL AIRPORT  
 (Base Case)

For 6.681 kg/s (636.3 tons/day) Average Output

Raw Materials

Feedstock (GH<sub>2</sub> at \$0.1645/lb) \$ 76 415 000

Chemicals

Sulfuric acid 243 000  
 Desiccants and adsorbents 93 000

Utilities

Electricity 248 380 kW (at \$0.02/kWh) 43 516 000  
 Cooling water makeup 662 000  
 Potable water 4 500

Labor

Operating Labor 1 092 000  
 Supervision 250 560

Administration and Overhead

919 940

Supplies

Operating 327 600  
 Maintenance 3 585 000

Taxes and Insurance

6 453 000

---

Total Annual Operating Cost \$133 561 600

TABLE XXIII. COST ASSUMPTIONS: HYDROGEN LIQUEFACTION/STORAGE  
COMPLEX, SAN FRANCISCO INTERNATIONAL AIRPORT

1. Investment includes liquefaction plant equipment and storage tanks but not refuel/defuel stands and apron, utility causeway or feeders, or fueling circuit.
2. Land assumed available at no cost.
3. Cost of landfill included.
4. Costs presented for mid-1975 dollars.
5. Average operating capacity of plant = 6.681 kg/s (636.3 TPD).
6. 350 operating days per year.
7. Electricity costs \$0.02 per kWh.
8. Cooling water makeup costs  $\$0.07925/\text{m}^3$  ( $\$0.30/1000$  gal).
9. Potable water makeup costs  $\$0.13209/\text{m}^3$  ( $\$0.50/1000$  gal).
10. Sulfuric acid costs  $\$0.05512/\text{kg}$  ( $\$50/\text{ton}$ ).
11.  $\text{H}_2$  feedstock costs  $\$0.3627/\text{kg}$  ( $16.45\phi/\text{lb}$ ) of liquid hydrogen produced.
12. Operating labor rate is  $\$6.50/\text{hr}$ .
13. Supervisory labor rates vary from  $\$15\ 750$  to  $\$33\ 000$  per year.
14. Office personnel labor rate averages  $\$5.50/\text{hr}$ .
15. Overhead costs at 60% of labor plus supervision.
16. Operating supplies are 30% of operating labor.
17. Maintenance supplies are 1.5% of investment.
18. Taxes and insurance are 2.7% of investment.
19. Para content of  $\text{LH}_2$  in storage = 97%+.
20. Para content of  $\text{LH}_2$  for operations = 60%.
21. 1985 - 2000 liquefaction technology.

two component systems. The LH<sub>2</sub> aircraft fuel system is described in Reference 2. The postulated fueling procedure for SFO is briefly described in Section 4.2.6 of the present report.

With an established aircraft fuel system and a feasible fueling procedure providing the primary ingredients to system formulation, a feasible ground distribution concept is identified through further consideration of the following:

- Vent gas disposition
- Transfer methods
- Defueling considerations
- Reliability/availability
- Instrumentation
- System arrangement
- Hazards analysis

It should be noted that the ground distribution system resulting from this analysis is not only feasible, but, in context with the study objectives, is both reasonable and appropriate for assessing the implications of handling LH<sub>2</sub>-fueled aircraft at SFO. That is not to say that this concept is the optimum solution (as might be derived by detailed design analysis) or that it would be equally appropriate at another airport location. As pointed out in Task 4, another airport site might very well require an entirely different approach to the fueling operation and attendant distribution system.

4.5.1 Fueling system description. - Development of a feasible LH<sub>2</sub> distribution and fueling system concept is, of course, largely dependent upon the location and nature of the aircraft fueling operation. The evaluation of alternative fueling procedures discussed in Task 4 concluded with the selection of a gate fueling system as the most appropriate for SFO. The distribution concept is, therefore, predicated on a fueling operation performed at the terminal gate by a fueler vehicle equipped to provide all necessary interfaces between a hydrant point of supply and the aircraft fuel system.

Each of the 19 gate fueling stations will consist of a hydrant pit (see Figure 23) containing interface connect points for LH<sub>2</sub> supply and hydrogen vent gas collection. The LH<sub>2</sub> hydrant can be connected to either of two vacuum jacketed distribution loops in which subcooled LH<sub>2</sub> is circulated from the storage facility at appropriate operating pressures. The vent hydrant will be connected to a vent collection header and routed to the storage and liquefaction facility. As shown in the figure, the hydrant pit is equipped with a riser from each of the LH<sub>2</sub> supply loops. The risers are connected

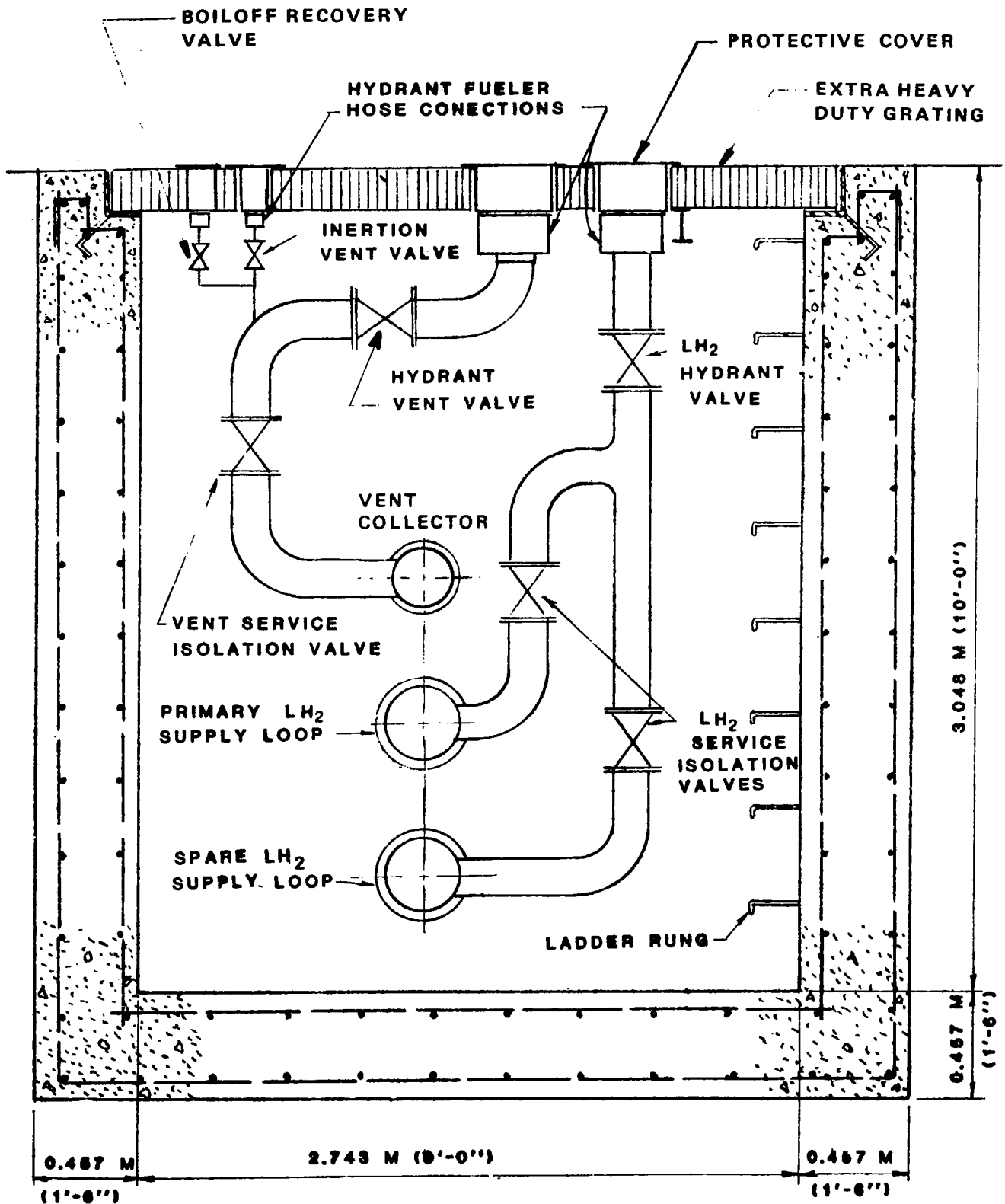

Figure 23. Typical Hydrant Pit

through service isolation valves to a hydrant shutoff valve and an LH<sub>2</sub> transfer disconnect device. The vent gas displaced from the aircraft tanks during refueling will be routed through the fueler vehicle to a vent disconnect device. A vent shutoff valve and service isolation valve connect the disconnect device to the vent collection header. This equipment will be situated in a pit located in the apron below the tail of the aircraft.

The refueling operation will be carried out by a hydrant fueler vehicle equipped to provide the fluid and operational interfaces between a hydrant pit and the aircraft. A flow schematic of the hydrant fueling operation is illustrated in Figure 24.

Vacuum jacketed metal bellows flex hose connections will be made from the hydrant truck to the LH<sub>2</sub> and vent connection devices in the pit. At the same time vacuum-jacketed flex hoses will be mated to the aircraft LH<sub>2</sub> and vent connect points using a cherry picker to lift a man to the 10 m (33 ft) height of the aircraft tail (see Figure 17). The hoses mated to the pit hydrants and to the aircraft are interconnected by vacuum jacketed piping complete with valves and instruments. The hydrant fueler truck will carry a vacuum pump, high pressure helium bottle and the necessary valves and controls to permit purification (the removal of all traces of air and moisture) of the flex hoses prior to the introduction of hydrogen.

Refer to Figure 23 for the following discussion of the fueling procedures. The purification process consists of evacuating the two liquid flex hoses and the two vent flex hoses to a level of 6.9 kPa (1 psia) or less with the vacuum pump (exhausting to atmosphere) followed by pressurization of the lines to 344.8 kPa (50 psia) with helium. Repetition of this evacuation/pressure cycle four times should reduce the air-moisture contamination to less than one part per million (ppm). The exact pressure levels and procedures to be used will be verified experimentally. A system leak check will be performed on the last purification cycle with the pressure at 344.8 kPa (50 psia).

All valves involved in the fueling operation are controlled from a sequencer on the fueler vehicle by means of an instrumentation and control cable connected both to the aircraft and the hydrant pit. The valves to be controlled are:

- Aircraft
  - Vent selector valve
  - Bleed valve
  - Fueling control valve
- Fueler Vehicle
  - Two LH<sub>2</sub> hose isolation valves
  - Two vent hose isolation valves
  - Purification and inertion valves
- Hydrant pit
  - LH<sub>2</sub> hydrant valve
  - Hydrant vent valve
  - Inertion vent valve



Upon completion of the purification sequence, the hydrant vent valve and fueler vent hose isolation valves are opened, the aircraft vent selector is set to the refueling position, and the bleed valve is opened. The fueler LH<sub>2</sub> hose isolation valves and the LH<sub>2</sub> hydrant valve are then opened, allowing LH<sub>2</sub> to circulate through the system via the bleed valve, to chill down the fueler system. When liquid temperatures are sensed at the aircraft, the bleed valve is closed, the fill valves are opened and tank filling commences. The tank level is monitored and when the level reaches the desired point and flow ceases, the fill valves are closed.

At the conclusion of the filling operation the LH<sub>2</sub> hydrant valve is closed, the aircraft vent selector is set to the tail vent position, and the bleed valve is opened. The hydrant vent valve and the four fueler hose isolation valves are closed, trapping cold hydrogen between each set of valves. This permits the piping section of the fueler, which represents about two-thirds of the fluid system mass, to remain chilled for the next fueling operation. Only the flex hose sections will require inertion before they are disconnected. Any pressure rise of the hydrogen in the piping sections due to heat leak will be relieved by the pressure safety valves shown in Figure 24. It should be noted that additional pressure relief valves will be required throughout the system; these have been omitted for clarity of presentation.

The inerting process (removal of the residual hydrogen) will consist of pressurizing the two LH<sub>2</sub> hoses and the two vent hoses with helium to 344.8 kPa (50 psia) and then venting them to the vent collection header via the inertion vent valve. This will vaporize any residual LH<sub>2</sub> in the fill hoses. The hoses are then evacuated to 6.9 kPa (1 psia) with the vacuum pump, exhausting to the vent collection header. The line will again be pressurized to 344.8 kPa (50 psia) with helium and vented. This evacuation/pressure cycle will be repeated twice to reduce the hydrogen concentration to 10 000 parts per million (ppm). The flex hoses are disconnected and the procedure is completed.

4.5.2 Ground distribution and refueling system. - The distribution of LH<sub>2</sub> throughout the terminal area to each of the 19 required gates presents some unique problems not encountered in previous systems associated with the space programs. The schedule and aircraft utilization constraints require that the LH<sub>2</sub> fueling system chilldown time be kept to a minimum. Operational flexibility is required which will permit an aircraft to obtain fuel upon arrival at its assigned gate without extensive planning and scheduling or elaborate communications with the LH<sub>2</sub> storage facility operator. Subcooled LH<sub>2</sub> must be supplied to the aircraft to minimize fuel losses due to flashing of the liquid after it is introduced into the tank. (This reduces the volumetric flow rate in the vent system, reducing aircraft vent system size and weight, and permitting higher fueling rates).

An LH<sub>2</sub> distribution system concept has been developed which addresses these requirements. This concept is depicted schematically in Figures 25 and 26. The basic system is a circulating LH<sub>2</sub> distribution loop which is fed

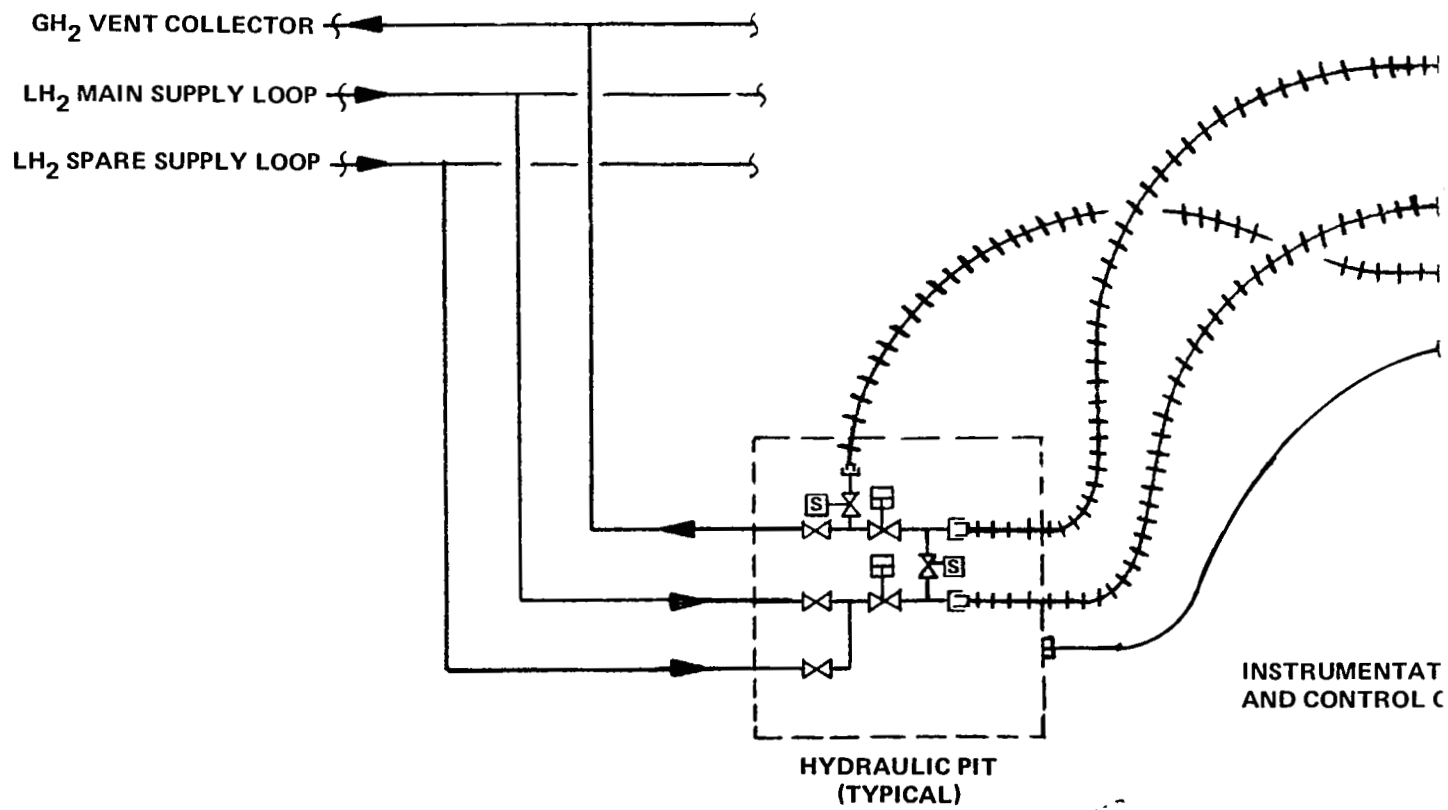

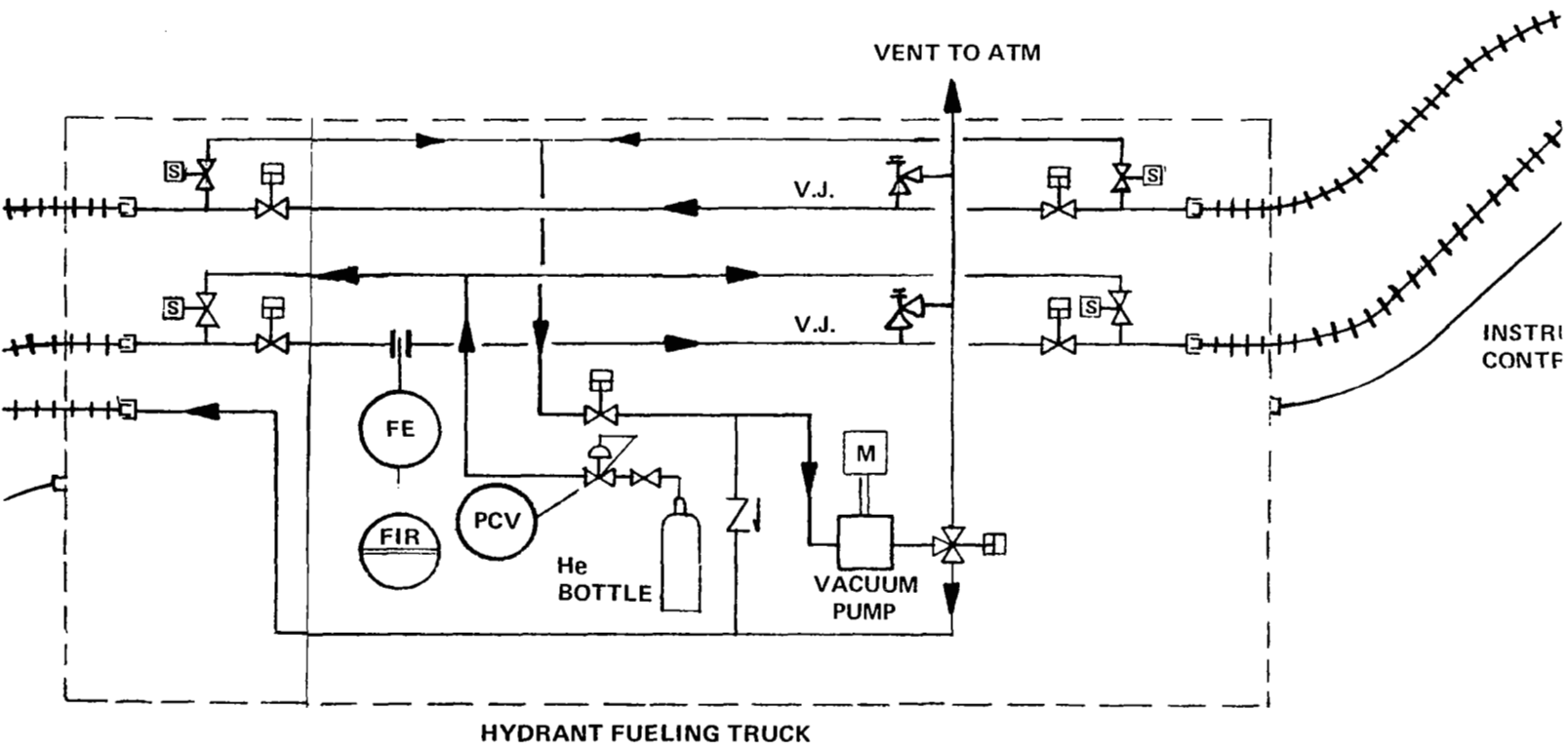

HYDRANT FUELING TRUCK

TATION  
OL CABLE

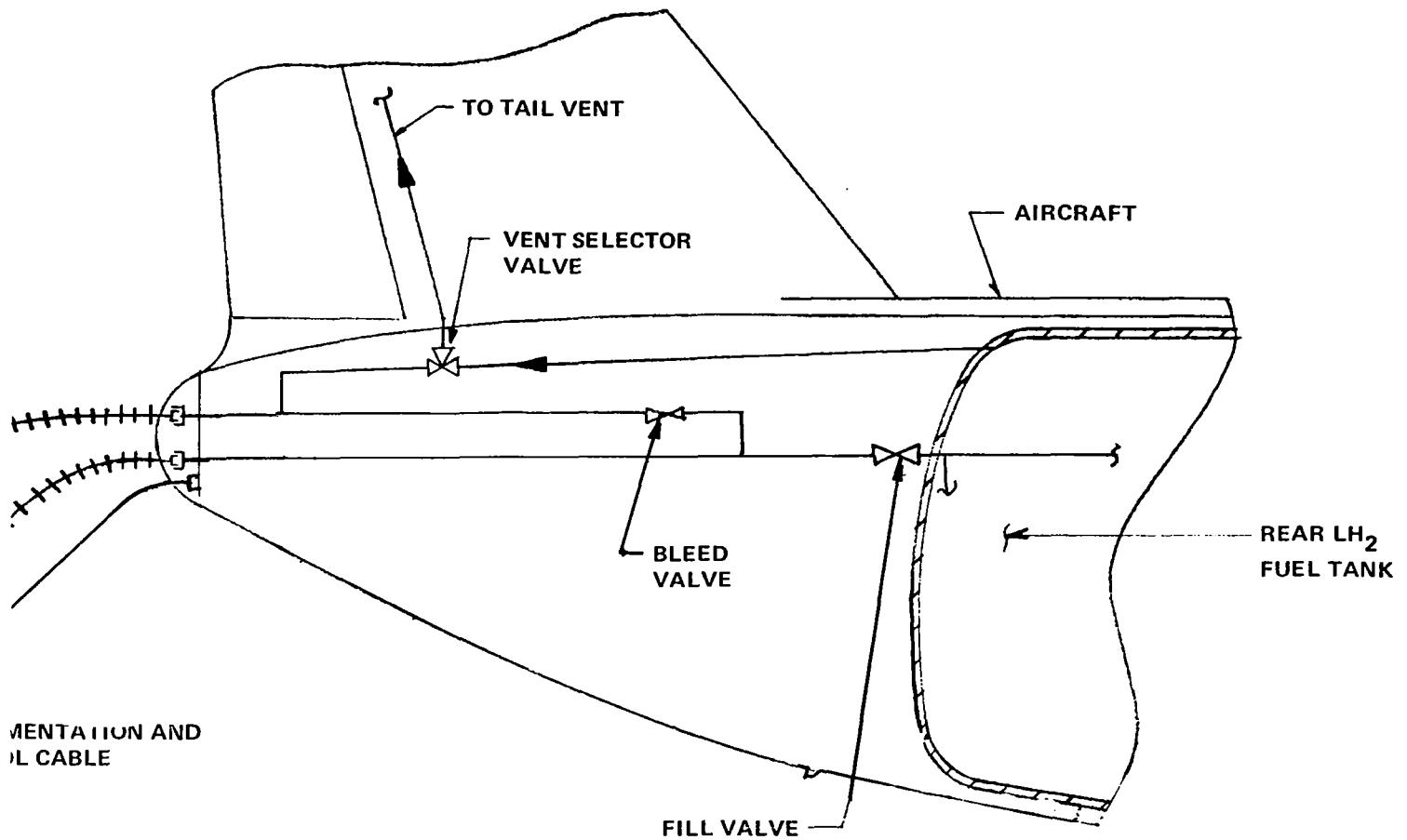

MENTATION AND  
IL CABLE

**SYMBOLS**

- |       |   |          |   |
|-------|---|----------|---|
| —     | PROCESS LINE  | ◇        | INTERLOCK                                 |
| +++++ | FLEXIBLE HOSE   | ⊖<br>FIC | FLOW INDICATING CONTROLLER                |
| —X—   | SERVICE ISOLATION VALVE   | ⊖<br>FIR | FLOW INDICATING RECORDER                  |
| —□—   | SOLENOID OPERATED VALVE   | ⊖<br>PCV | PRESSURE CONTROL VALVE                    |
| —⊖—   | HYDRAULIC OR PNEUMATIC PISTON<br>OPERATED CONTROL VALVE           | ⊖<br>TE  | TEMPERATURE ELEMENT                       |
| —⊖—   | HYDRAULIC OR PNEUMATIC PISTON<br>THREE-WAY OPERATED CONTROL VALVE | ⊖<br>PE  | PRESSURE ELEMENT                          |
| —X—   | THREE-WAY VALVE   | ⊖<br>FE  | FLOW ELEMENT                              |
| —Z—   | CHECK VALVE   | ⊖<br>M   | MOTOR DRIVEN CENTRIFUGAL PUMP             |
| —X—   | BACK PRESSURE REGULATOR<br>SELF CONTAINED                         | ⊖<br>M—K | MOTOR DRIVEN RECIPROCATING<br>COMPRESSOR  |
| —⊖—   | DIAPHRAGM OPERATED VALVE  | ⊖<br>M—V | MOTOR DRIVEN RECIPROCATING<br>VACUUM PUMP |
| —(F)— | FILTER  | —□—      | COUPLING                                  |
| ---   | ELECTRIC SIGNAL   | ⊖        | PRESSURE RELIEF VALVE                     |

Figure 24. Hydrant Fueling Schematic

with  $-252.8^{\circ}\text{C}$  ( $-423^{\circ}\text{F}$ ) saturated  $\text{LH}_2$  from a storage dewar. The liquid loop is routed past each of the 19 hydrant pits (one for each gate), then returned to the storage system (Figure 27).

$\text{LH}_2$  is circulated through the loop at a flow rate sufficient to limit the temperature rise due to heat leak to  $1.0^{\circ}\text{C}$  ( $1.8^{\circ}\text{F}$ ), the saturated equivalent of 137.9 kPa (20 psia),  $-251.7^{\circ}\text{C}$  ( $-421.2^{\circ}\text{F}$ ), at the last hydrant on the loop. The circulating liquid is then returned to the storage area where it is introduced into a vented storage dewar to be boiled back to saturation conditions at 103.4 kPa (15 psia). It should be noted that no additional  $\text{LH}_2$  loss penalty is incurred by this operating method because the frequency of system operation is such that the inner line of the vacuum insulated pipe will not warm up significantly above liquid temperatures. Thus, the heat leak into the distribution system will remain essentially constant no matter what the liquid flow rate. The primary advantages of this approach are the virtual elimination of chilldown time and the immediate availability of subcooled  $\text{LH}_2$  at each hydrant station, with the additional benefit of reduced  $\text{LH}_2$  losses normally incurred by droplet carryover during chilldown of the ground distribution system.

System operating flexibility is assured by a distribution pressure control system which provides constant  $\text{LH}_2$  pressure to the hydrants and the fueller vehicle. The  $\text{LH}_2$  loop will operate at 241.3 kPa (35 psia), allowing a 48.3 kPa (7 psia) loss through the hydrant valve and the fueller vehicle to ensure a 193.1 kPa (28 psia) aircraft interface pressure when fueling at the design rate of 11 354 l/m (3000 gpm) to the design aircraft tank pressure of 144.8 kPa (21 psia). The pressure in the loop is controlled by a back pressure regulator located at the storage area end of the  $\text{LH}_2$  return line. This valve is controlled by a pressure sensor located at the last hydrant on the loop. As the back pressure regulator reaches the extremes of its available control range, transfer pumps are either brought on line or dropped off line, as required to maintain the constant  $\text{LH}_2$  supply pressure. During idle periods, one transfer pump remains on line to insure the availability of subcooled liquid and to maintain constant supply pressure. The rationale for development of the transfer method concept is discussed in Section 4.5.3.

The operation of the hydrant fueller vehicle (see Section 4.5.1) is relatively immune to problems of schedule and communication constraints between the actual fueling operation and the operation of the central storage and transfer system.

4.5.3  $\text{LH}_2$  transfer method. - Both pressurized storage dewar transfer and pump transfer were considered as methods of moving fuel from storage to aircraft. The pressurized storage dewar transfer method offers the obvious advantage of system simplicity (in that the problems associated with mechanical pumps are eliminated) and a degree of flexibility (in flow rate vs demand), not available in a pump fed system.

There are, however, some disadvantages to a pressure fed system. The most significant of these includes losses through heat transfer from the pressurant gas to the liquid and the need to vent the storage tank back to

103.4 kPa (15 psia) between each transfer to maintain saturated liquid in the storage tank; these were discussed in more detail in Section 4.1. These items increase the system liquid loss from 15.77% using transfer pumps to 51.9% for the pressure method. Another factor is the added cost of storage dewars capable of operating at the higher working pressures but these would have to be measured against the cost of transfer pumps.

A pump fed system also has drawbacks, principally the increased system complexity with the attendant degradation in reliability. In addition, the required demand flexibility is somewhat more difficult to achieve. It was concluded, however, that the lower losses associated with pump transfer were sufficiently attractive that system would be adopted for this analysis.

The proposed LH<sub>2</sub> distribution system consists of a pump fed system operating on an uninterrupted basis requiring only one tank pressurization cycle as described in the Task 3 narrative. The proposed system addresses the major drawbacks of a pump fed system, those of reliability and demand flexibility. To provide the necessary reliability, multiple pumps are contemplated. Each of these pumps is rated at 11 354 l/m (3000 gpm) and has the capacity to fuel one aircraft at the design flow rate. Demand flexibility is achieved by sequencing one or more pumps on line on the basis of distribution loop back pressure control, as described in Section 4.5.2. These pumps are close-coupled to the storage dewars to minimize heat leak into the pump suction piping, thus avoiding pump start up problems caused by two-phase fluid and the attendant lack of net positive suction head (NPSH). The close coupled configuration limits flexibility to the extent that a pump can be utilized only to withdraw LH<sub>2</sub> from the dewar to which it is mated. In normal conditions, all fueling operations are supplied from one dewar. Thus, all five storage dewars are equipped with pumps so that all may provide the distribution. At the design peak four aircraft may require fuel simultaneously, thus, four 11 354 l/m (3000 gpm) rated pumps are required per storage dewar. This provides 100% pump capacity redundancy during normal operation (two aircraft fueling); during peak periods a pump outage will require that one of the reserve dewars be brought on line to provide sufficient pump capacity.

The amount of LH<sub>2</sub> to be circulated through the distribution loop during idle periods to maintain the required liquid quality has been determined to be on the order of 3028 l/m (800 gpm). Separate pumps rated at 3028 l/m (800 gpm) each could be provided for each storage dewar to supply the minimum circulation flow (ten additional pumps). However, the heat leak of the piping associated with these pumps and the complexity of additional valves, controls and instrumentation does not appear advantageous when compared to providing the circulation flow with one of the main transfer pumps at 11 354 l/m (3000 gpm). The only penalty incurred with this approach is a slight increase in LH<sub>2</sub> losses due to excessive pump work. However, as a result of circulating at the higher rate, the maximum time that a supply dewar will remain pressurized, before the liquid is depleted by circulation to the return dewar, is approximately 5-1/2 hours. The bulk temperature rise of the liquid in the supply dewar should not exceed the operating limits during this period, permitting uninterrupted operation of a dewar from full

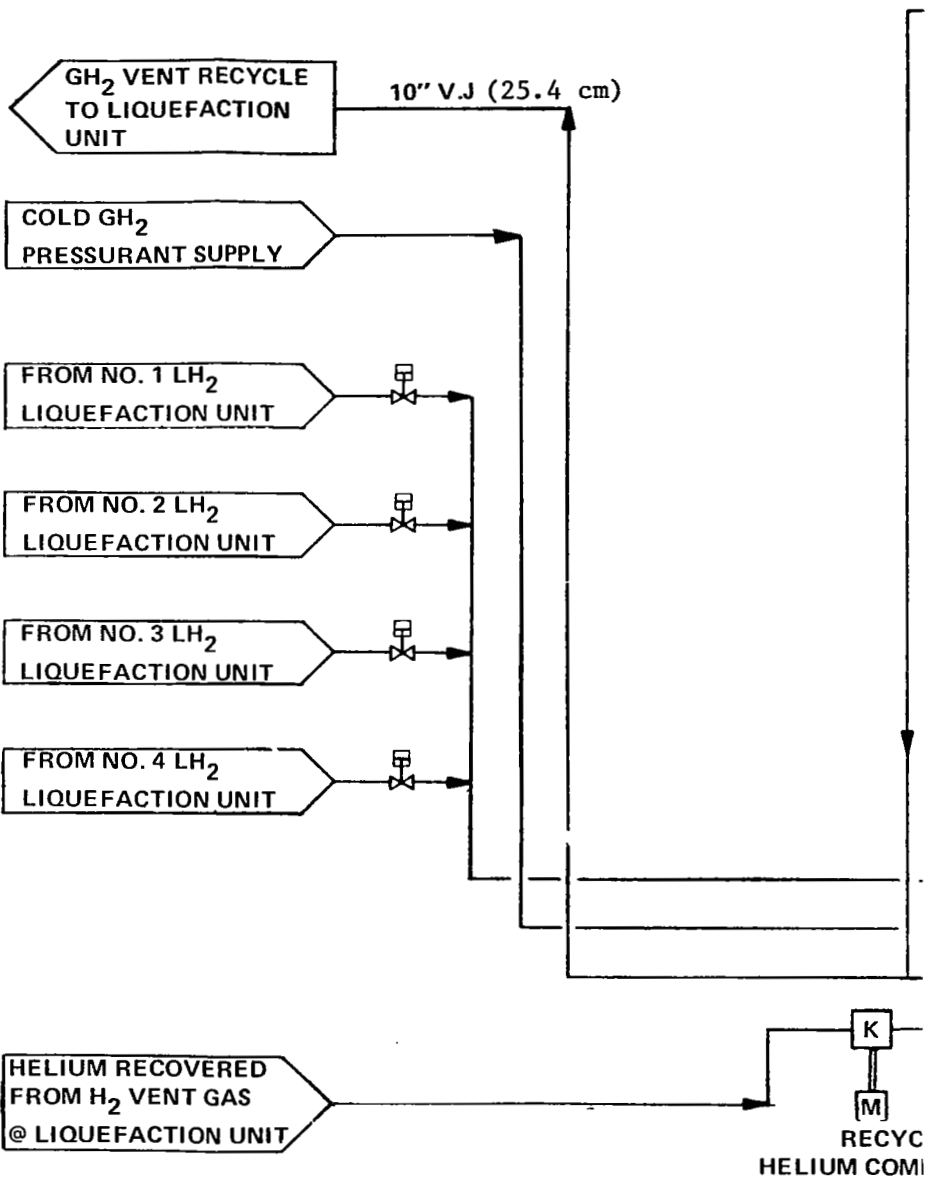

NO. 1 OF 5 LH<sub>2</sub> STORAGE DEWAR

1,000,000 + GAL  
(3785 + m<sup>3</sup>)

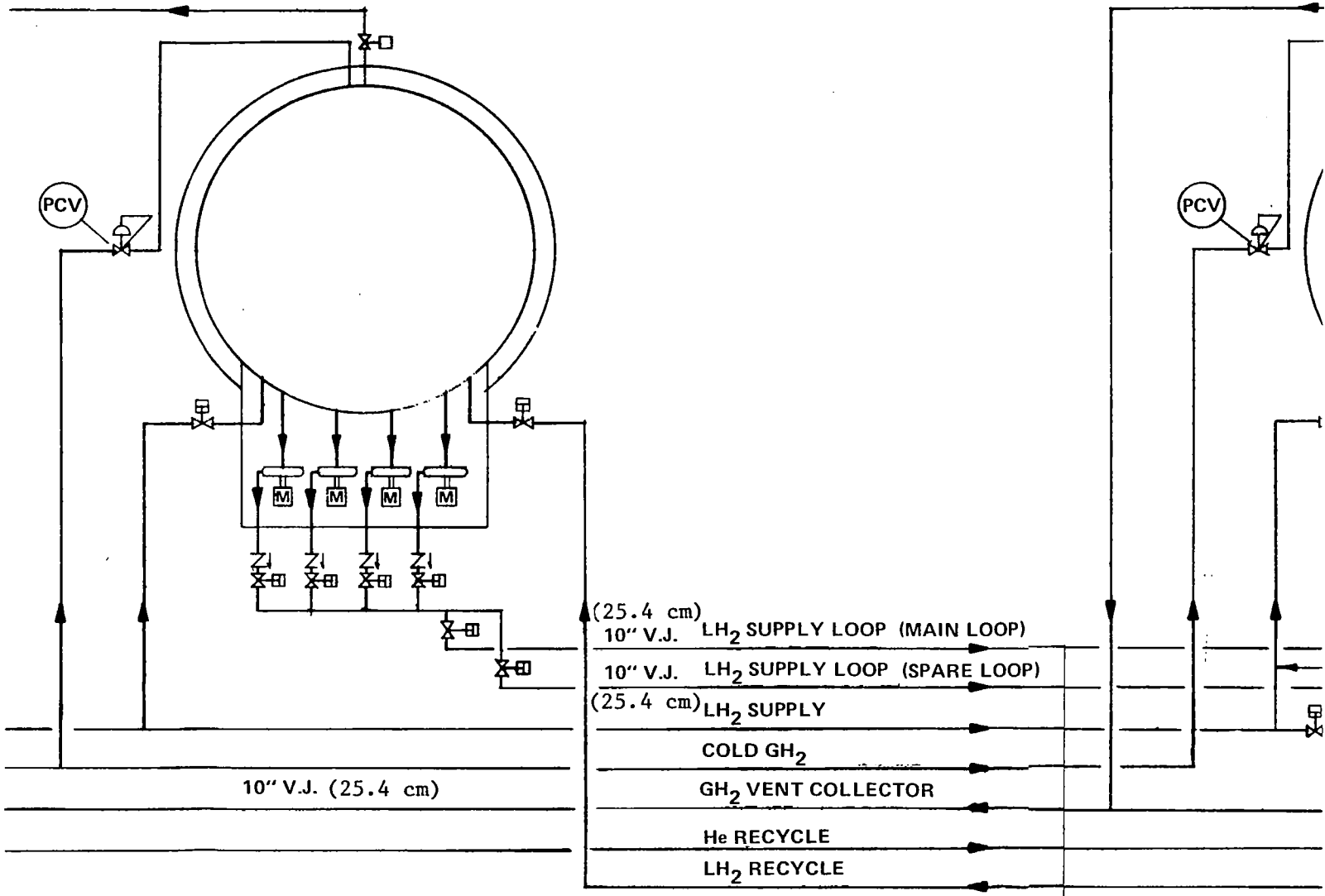

LH<sub>2</sub> TRANSFER PUMPS

3,000 GPM (or 11.35 m<sup>3</sup>/min)  
(TYPICAL OF 4)

E  
RESSOR



5 OF 5 LH<sub>2</sub> STORAGE DEWAR

1,000,000 + GAL

(3785 + m<sup>3</sup>)

NOTE:  
PRESSURE RELIEF VALVES  
NOT SHOWN FOR CLARITY

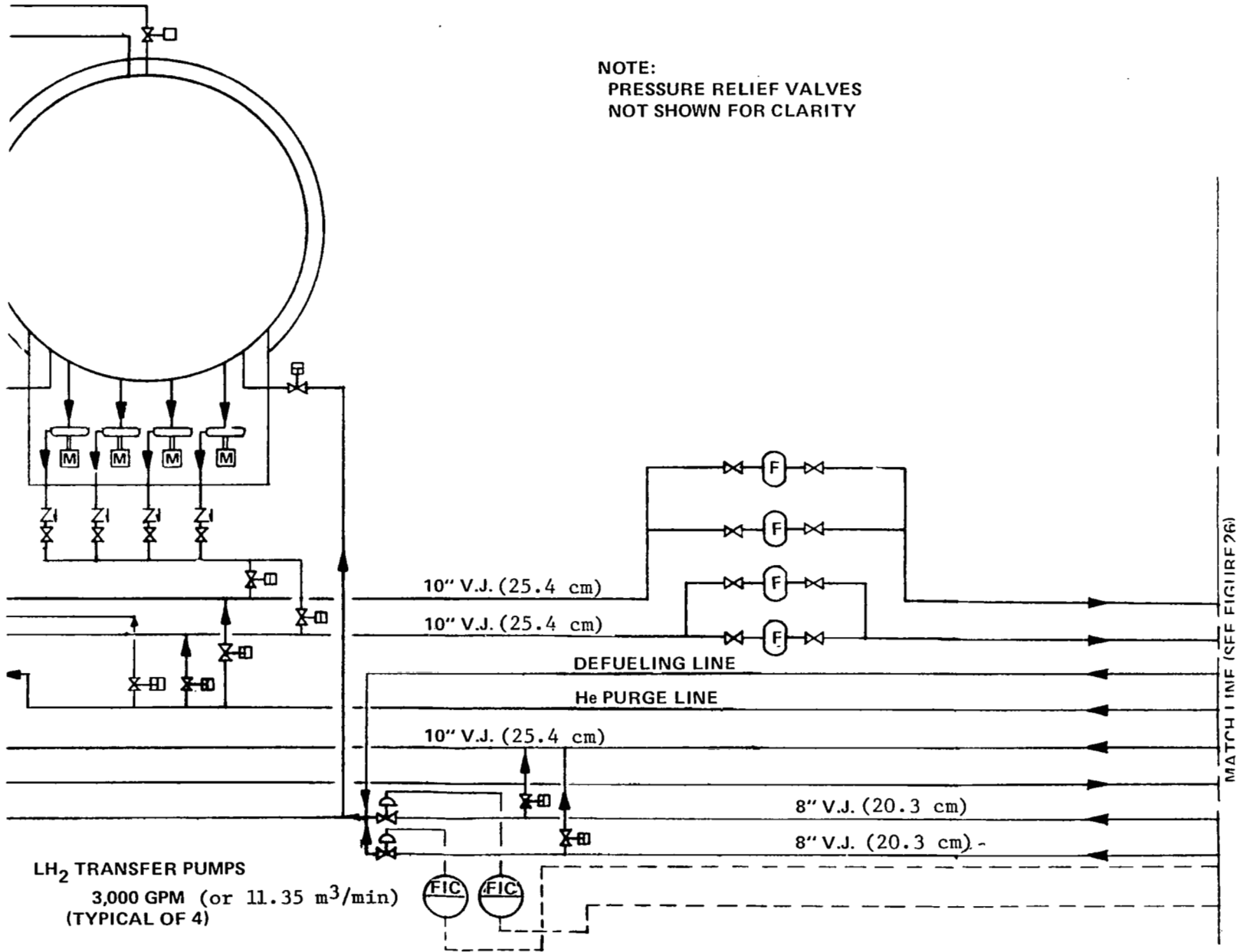

Figure 25. Distribution System Schematic

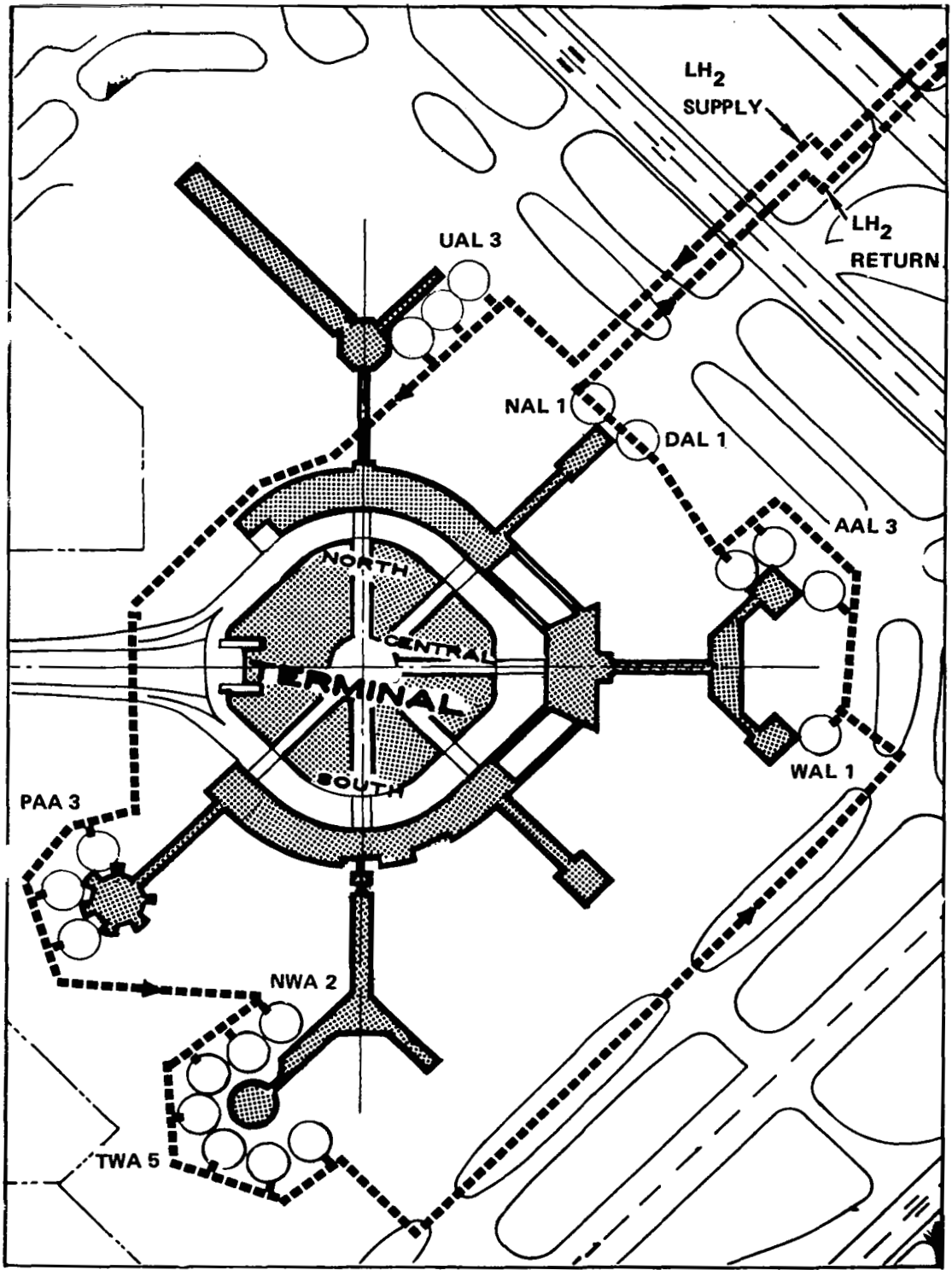

Figure 27. LH<sub>2</sub> Distribution Loop Concept Plan

to empty without venting and repressurization and avoiding the associated losses. Accordingly, circulation of LH<sub>2</sub> through the distribution system during periods when no aircraft are refueling will be provided by one of the 11 354 l/m (3000 gpm) pumps.

4.5.4 Vent gas disposition. - The operation of a liquid hydrogen system produces hydrogen gas from boil-off of stored liquid, and from vaporization of liquid used to chill down piping, tanks and equipment. Volumes of the gas are also displaced from tanks during the filling operation. This hydrogen gas has been traditionally disposed of by burning in air through a flare stack or bubble pond. However, the unique aspects of the airport hydrogen production, distribution and fueling systems make it advantageous to recover and recycle this hydrogen gas. The advantages include: 1) conservation of the refrigeration energy contained in the cold vent gas stream; 2) recovery of the hydrogen molecule, thus, reducing the GH<sub>2</sub> feed rate by approximately 12 to 15 percent; and 3) eliminating the need for an extensive hydrogen gas burn-off system with its attendant siting problems.

The aspect of the airport system which encourages the recovery approach is the on-site location of the liquefaction plant. This allows the cold vent gas at approximately -240°C (-400°F), to be returned and inserted at an appropriate point in the liquefaction process that can effectively make use of the refrigeration energy in the cold gas stream. This requires that an efficient insulation be used on the vent collection header. The proposed concept uses vacuum jacketed pipe for the vent gas system.

The reintroduction of the recovered vent gas into the liquefier does present a problem of gas purity. The cold gas stream must not contain condensable gases such as N<sub>2</sub>, O<sub>2</sub>, CO<sub>2</sub> or water vapor; it must consist of only H<sub>2</sub>, with limited quantities of He permitted. To this end, all sources of these gases have been excluded from the concept and the helium/vacuum purification-inertion system previously described has been incorporated in the hydrant fueller truck. This permits air and moisture to be withdrawn from the fueling hoses and vented to the atmosphere during the prefueling purification cycles, and gaseous hydrogen to be purged from the hoses to the vent collection header by helium pressure/vacuum during the post-fueling inertion cycles. The resulting small quantities of helium contained in the otherwise pure hydrogen gas stream is separated from the hydrogen in the natural course of the liquefaction process in that it does not liquefy, and may be drawn off and compressed for reuse.

Matching the hydrogen gas recovery rate with the liquefaction process demand rate will require surge capacity in the form of an insulated or vacuum jacketed vessel. The sizing of this vessel and methods of matching recovery and demand rates will require study beyond the scope of this investigation; however, the requirement for a GH<sub>2</sub> holding dewar is indicated on Figure 21.

In addition to the vent gas recovered during routine fueling operations, other sources of recoverable hydrogen gas include:

- The gas evolved by the boil-down of liquid in the return dewar (which contains the heat added by transfer pump work and distribution system heat leak).
- The vent down of the supply dewar following dispensing of its contents.
- The boil-off from the three reserve storage dewars.
- The tank boil-off from fueled aircraft parked for extended periods of time (including aircraft in maintenance facilities equipped with vent collection systems).

The recoverable hydrogen gas from vaporized chilldown liquid is limited to that evolved during chilldown of a warm distribution loop and chilldown of the hydrant fueler hoses during each refueling operation.

During the fueling operation the ullage gas displaced from the aircraft tanks is routed from the tank vent selector valve to the vent collection header via the hydrant fueler vehicle.

Recovery of tank boil-off from aircraft that are to be parked for extended periods (such as overnight parking at a gate) will be accomplished by a vacuum-jacketed flex hose connected between the hydrant pit (see Figure 22) and the aircraft. The procedure will require use of the hydrant fueler vehicle to perform purification steps and for making the flex hose connection to the aircraft vent connect point. The insulated flex hose should be protected from potential damage by miscellaneous ground service equipment during the storage period while the hydrant fueler vehicle is not there, perhaps by barricade posts that "pop-up" from the apron. Prior to aircraft departure, the hydrant fueler vehicle would return, the vent hose would be disconnected, and trip fueling as described in section 4.5.1 would be performed.

4.5.5 Defueling/refueling for aircraft maintenance. - Defueling of the LH<sub>2</sub> aircraft will be necessary for extended out-of-service periods for major maintenance or when fuel tank repair is required. Defueling of the aircraft tanks will be accomplished through the defueling valve by operating the aircraft tank-mounted boost pumps, with the fuel being returned to storage by one of the following methods:

- At a special area designated for defueling/refueling extended out-of-service aircraft (separate return line).
- At the service refueling station (gate), pumping the liquid back into the main distribution system.

- Use of truck-trailer transports.
- Use of demountable tanks (external tank design).

The use of truck-trailer transports for returning fuel to storage seems impractical unless relatively small quantities of LH<sub>2</sub> are involved, and unless there is a requirement for a mobile source of LH<sub>2</sub>. This procedure would incur significant on-and-off loading transfer losses, and, more importantly, would require costly special equipment that would be utilized only infrequently. As a result, whether defueling is performed at the gate or at some other remote airport location, use of truck-trailer transports is not economically attractive over the inherently short distances that fuel would have to be transferred at SFO.

Consideration of a defueling procedure utilizing demountable tanks is, of course, predicated on the external tank aircraft design. The concept of removable tanks has advantages with respect to maintenance considerations and a unique potential for refueling and defueling. As pointed out in Task 4, however, site constraints at SFO militate against any of the ground concepts built around remote facilities. In addition, operational disadvantages weigh against the External Tank design.

The question remaining, then, is whether aircraft defueling might best be performed at the mission refueling station (in this case the terminal gate) or at some other designated airport location. This question is answered primarily through consideration of "defueling time". Although the time required to defuel an aircraft will be dependent upon the capacity of the aircraft pumps and fuel lines, it is probable that defueling (defuel and inert) will require four to six hours for a full tank. As a result, it was concluded that aircraft defueling, though occurring only infrequently, should be separated from terminal gate activity related to in-service aircraft. This conclusion is reinforced by consideration of operational safety, efficiency of vehicle and aircraft ground traffic, and the associated impact on terminal operations.

The defueling operation can most appropriately be accommodated at the same site designated for fueling aircraft that are being returned to service following maintenance. A basic assumption of the refueling procedure adopted in Task 4 was that aircraft would not remain at the gate for extended periods and that only trip fueling of aircraft with cold tanks would be performed at the gate. Further, it has been postulated that chilldown and fueling of aircraft coming from maintenance or long-term remote parking will be performed at a special fueling area, preferably in close proximity to the LH<sub>2</sub> storage facility.

A special fueling area is envisioned adjacent to the LH<sub>2</sub> storage facility, providing several defueling or refueling positions. This concept of a special facility for refueling/defueling extended out-of-service aircraft is attractive both from the standpoint of economics and airport operations.

As discussed in Task 8, all possible aircraft maintenance will be performed with the aircraft in the fueled condition. However, those functions requiring work directly on the fuel tanks will necessitate defueling of the aircraft and subsequent refueling. The cryogenic nature of the fuel requires that unique procedures be performed prior to initiation of the tank maintenance and again prior to returning the aircraft to service. These operations consist of inerting of the tank (the removal of hydrogen gas to a concentration of 10 000 ppm or less), and controlled warmup of the tank to a temperature above dew point to prevent moisture condensation.

Following the completion of tank maintenance, the tanks must be purified (removal of all traces of air and moisture to a contamination level of 1 to 10 ppm) prior to chilldown and refueling.

These functions (defueling, inerting, warmup, purification, chilldown, and refueling) require sufficient specialized equipment to warrant consideration of a centralized facility capable of serving all carriers. This facility might be located adjacent to the liquefaction and storage complex to minimize piping and operational interface problems.

With the aircraft tail situated at the defuel/refuel stand, a flex hose is mated to the fuel connect point at the tail cone of the aircraft. The interconnect hose is purified and the contents of the tank are pumped to the LH<sub>2</sub> return storage dewar via the LH<sub>2</sub> return header.

The initial phase of aircraft fuel tank warmup must be performed using heated hydrogen gas as the heat source fluid. The warm hydrogen gas must be used until the tank wall temperature is brought above the nitrogen condensation temperature of -195.5°C (-320°F). At that point the heat source fluid may be switched to dry nitrogen gas.

The most effective procedure to expedite tank warmup is the introduction of the heated gas 93.3°C to 148.9°C (200°F to 300°F) into the tank with the vent closed and subsequent pressurization of the tank to its maximum sea level pressure. This pressure is held for two to five minutes to permit heat transfer from the gas to the tank. The tank is then vented to the GH<sub>2</sub> recovery header or to the atmospheric flare stack during and after the switch to heated nitrogen. This procedure is repeated until the tank wall is above the dew point temperature for ambient atmosphere, at which point enough nitrogen has been cycled through the tank to effect tank inertion. The aircraft, having been defueled, warmed, and inerted, is then moved to the maintenance facility for the required maintenance.

Prior to the introduction of hydrogen into the tanks of an aircraft returning from maintenance, air or oxygen must be removed from the tank. If the aircraft is to be refueled with liquid hydrogen, then all traces of condensable gases such as nitrogen, carbon dioxide, and water vapor must also be removed. If the maintenance activity has introduced little or no air into the tanks, then purification of the tanks may be accomplished by pressure/vent cycling the tank with hydrogen gas to reduce the condensable contamination level to between one and ten parts per million. If air has been

introduced into the tank, then a nitrogen pressure/vent cycle is required prior to the hydrogen gas cycle to reduce the air contamination level to 10 000 parts per million. This procedure is then followed by the cold hydrogen gas purification cycling as described above.

Fueling an empty tank must be performed at low rates to avoid over-pressurizing the aircraft tank. As the liquid is introduced, it flashes to vapor and the tank vent tends to choke. To avoid overpressurizing the tank, the refueling stand is equipped with a pressure control valve which meters the liquid fed from the distribution system into the aircraft tank by sensing tank pressure. The vent gases evolved during refueling are collected in the  $\text{GH}_2$  recovery header. The procedures described above for aircraft tank chill-down and fueling may take from two to twelve hours, dependent on tank mass, configuration and tank vent capacity.

4.5.6 System reliability and availability. - It is obvious that airline operations are completely dependent upon the continuous supply of fuel from the  $\text{LH}_2$  production, storage, distribution and fueling systems, and cannot tolerate a complete outage in the availability of  $\text{LH}_2$ . It is assumed that contingency procedures can be postulated to permit continued  $\text{LH}_2$  delivery in the event of system failure. The following is a summary of the major systems and typical contingency procedures for system or component failure in each of them:

- Liquefaction Plant. - The proposed plant, as described in the Task 6 narrative, consists of four totally independent production modules, any three of which can produce all but peak demand and any two of which can produce 80% of average demand. This redundancy should provide sufficient  $\text{LH}_2$  product availability to meet most emergency shutdowns.
- $\text{LH}_2$  Storage. - The proposed  $\text{LH}_2$  storage consists of five storage dewars each of one million gallon capacity. During a peak month, the average daily demand is approximately  $10\,977\text{ m}^3$  (2.9 million gallons). Three of these dewars will be maintained in a topped off condition to provide a minimum of 24 hour reserve. A fourth dewar will be on line feeding the distribution system with the remaining dewar vented to accept  $\text{LH}_2$  production output and liquid returned from the circulating distribution loop. Under normal conditions, the two operating dewars (supply and return) will contain at least a million gallons between them, so that a total reserve of  $1762\text{ m}^3$  (4 million gallons) may be assumed to be available. All dewars will be configured to serve as (1) reserve storage, (2)  $\text{LH}_2$  supply, and (3)  $\text{LH}_2$  receiver, thus, all of the required functions can be performed by any dewar and one dewar can be out of service with no detrimental effect. When two or three dewars are out of service, only the desired reserve capacity would be reduced.

- LH<sub>2</sub> Distribution. - The concept of a single LH<sub>2</sub> distribution loop from the storage complex to the gate hydrant pits introduces significant system availability problems in the event of downtime. The loss of vacuum in any vacuum insulated pipe section would immediately reduce system operating efficiency, and the downtime of the entire fueling system required for the repair of such a problem would be intolerable. Thus, the suggested distribution concept incorporates redundant LH<sub>2</sub> circulating distribution loops. Any storage tank is capable of feeding either an in-service supply loop or the standby supply loop. Both loops are routed to each hydrant pit where service isolation valves permit the hydrant feed to be selected from either subsystem.

Each loop will nominally be capable of fueling two aircraft simultaneously at the design flow rate of 11 354 l/m (3000 gpm) each. Peak demand (summer months) requires capability to fuel four aircraft simultaneously, and both loops would be in service during these periods. True redundancy is not achieved with the dual loops, in that fueling capability is below design loads if one loop malfunctions in the busy months. However, continuity of service can be maintained. In the event of a pipe section vacuum failure, a correction can be effected by removal and replacement of the defective pipe section with a certified spare section. Assuming that cryogenic system maintenance capability is available at the airport site (see Section 5.1.3.1), it is estimated that from 8-12 hours would be required to replace the defective pipe section and return the loop to service. Repair of the defective section would be performed in a central facility.

4.5.7 Instrumentation. - Several operating parameters of the fueling process must be monitored to assure proper system operation. These include:

- Storage dewar pressure
- Distribution loop LH<sub>2</sub> temperatures
- Fueler hose pressure/vacuum
- vacuum insulation pressure
- Storage dewar quantity

The quantity of LH<sub>2</sub> dispensed to a given aircraft must also be accurately metered. The following brief discussion describes typical instrumentation equipment for measurement of these parameters based on the current state of the art.

- Dewar Pressure. - A strain gage type of absolute pressure transducer with a nominal 5 volt dc output could be used for this application. Digital display readouts would be standard.



- Distribution Loop Temperatures. - Platinum element resistance temperature bulbs could be incorporated at several points throughout the system. Again, digital readouts would be used.
- Fueler Hose Pressure/Vacuum. - A strain gage would be used for this application to monitor the pressure levels during the purification and inertion cycles.
- Vacuum Insulation Pressure. - A thermocouple type gage would be used to indicate the low vacuum existing in the insulation jacket.
- Storage Dewar Quantity. - A sensitive differential pressure cell will provide sufficient accuracy to determine the quantity of LH<sub>2</sub> in storage.
- LH<sub>2</sub> Delivery Quantity. - The quantity of liquid fuel delivered is critical for accounting purposes and as a cross check against the aircraft level gages to determine the actual quantity of fuel loaded. A turbine type flowmeter mounted in the LH<sub>2</sub> piping on the hydrant fueler vehicle appears to be a satisfactory method. This unit would require periodic calibration to ensure that the required measurement precision is maintained. The flow measurement will require that the temperature and pressure of the liquid in the line be simultaneously measured and the proper density corrections applied. The turbine speed, the calibration value and the LH<sub>2</sub> temperature and pressure will be fed into a computational unit to provide an output of flow rate. The output could be displayed on a digital readout for the fueler operator and provided to other monitor locations by telemetry. The flow rate, with an integral time signal, can provide an output of gross delivered quantity.

As LH<sub>2</sub> is circulated through the distribution system, there will be a temperature difference of the subcooled liquid between the first and last hydrants on the distribution loop. The colder liquid at the first hydrants will have lower flash losses in the aircraft tank than the liquid dispensed from the later hydrants on the loop. It may be necessary to develop a mensuration unit and related instrumentation technology to state net fuel delivered in terms of available energy. Such problems will be routinely resolved as the technology for commercial use of the fuel evolves.

4.5.8 System arrangement/installation concept. - The LH<sub>2</sub> distribution system concept introduced in Section 4.5.2 employs a loop in which LH<sub>2</sub> is continuously circulated past each of the 19 hydrant stations and returned to the storage system. It is considered desirable that this LH<sub>2</sub> circulating loop be routed predominately in an open trench with minimum use of underground (covered) routing of the hydrogen transport lines. This requirement is derived primarily from consideration of the following needs:

- To provide a high degree of line accessibility for system maintenance, repair, and inspection.

- To make maximum use of a self-venting enclosure (open trench with steel grating) to prevent the collection of air-hydrogen mixture in the event of leakage or line failure.

It should be pointed out that underground line routing is not necessarily limited by ventilation considerations. The use of significant lengths of tunnel, however, will require special provisions for venting the enclosure, such as a system of forced evacuation of air exchange and perhaps even a backup system. As a result, the self-venting or open trench concept is considered preferable, subject, of course, to any special limitations imposed by physical constraints and/or aircraft movement demands.

In assessing the feasibility of the open trench concept for use in aircraft movement areas, consideration was given to utilizing heavy steel grating for the trench cover. Since investigations have indicated that a heavy duty steel grating can readily accommodate the maximum aircraft wheel loads, it follows that aircraft operations in the vicinity of the lines do not place limitations on the use of the self-venting trench enclosure. It is proposed, therefore, that the LH<sub>2</sub> distribution system be routed below grade in a concrete lined "open" trench covered with steel grating (Figure 28).

The figure illustrates the trench in the section of the circuit where LH<sub>2</sub> return lines are included. Although it is recognized that an optimized design could conceivably identify sections where underground (tunnel) line routing would be acceptable, it is felt that application of the open trench concept to the full length of the distribution loop is entirely feasible. In any case, this concept is preferable during the early periods of fuel usage by virtue of providing maximum self-venting of the trench and maximum line access and maintainability.

While the use of the open trench with steel grating cover for runway crossings is considered feasible in this application, utilization of this concept near runway ends or near the point of aircraft rotation may not be desirable. It should also be noted that the steel grating is potentially damaging to current aircraft tires and grating/tire design interface coordination may be needed to minimize this problem, for example, solid covers could be used where the tunnels cross runways.

Design of the trench section is such that the trench details (member thickness and steel requirements) will not change significantly over the length of the distribution system. The details of trench design are, therefore, assumed to remain relatively constant over the length of the loop and, for purposes of this analysis, no attempt has been made to optimize the design in terms of variable loading. On the other hand, there appears to be substantial opportunity to vary the steel cover grating design as a function of the vertical loading condition (ranging from aircraft loads to occasional pedestrian loads). Of course, a heavy steel grating designed for aircraft loads will be required in all apron areas, as well as runway and taxiway crossings, and it is suggested that the heavy grating should be

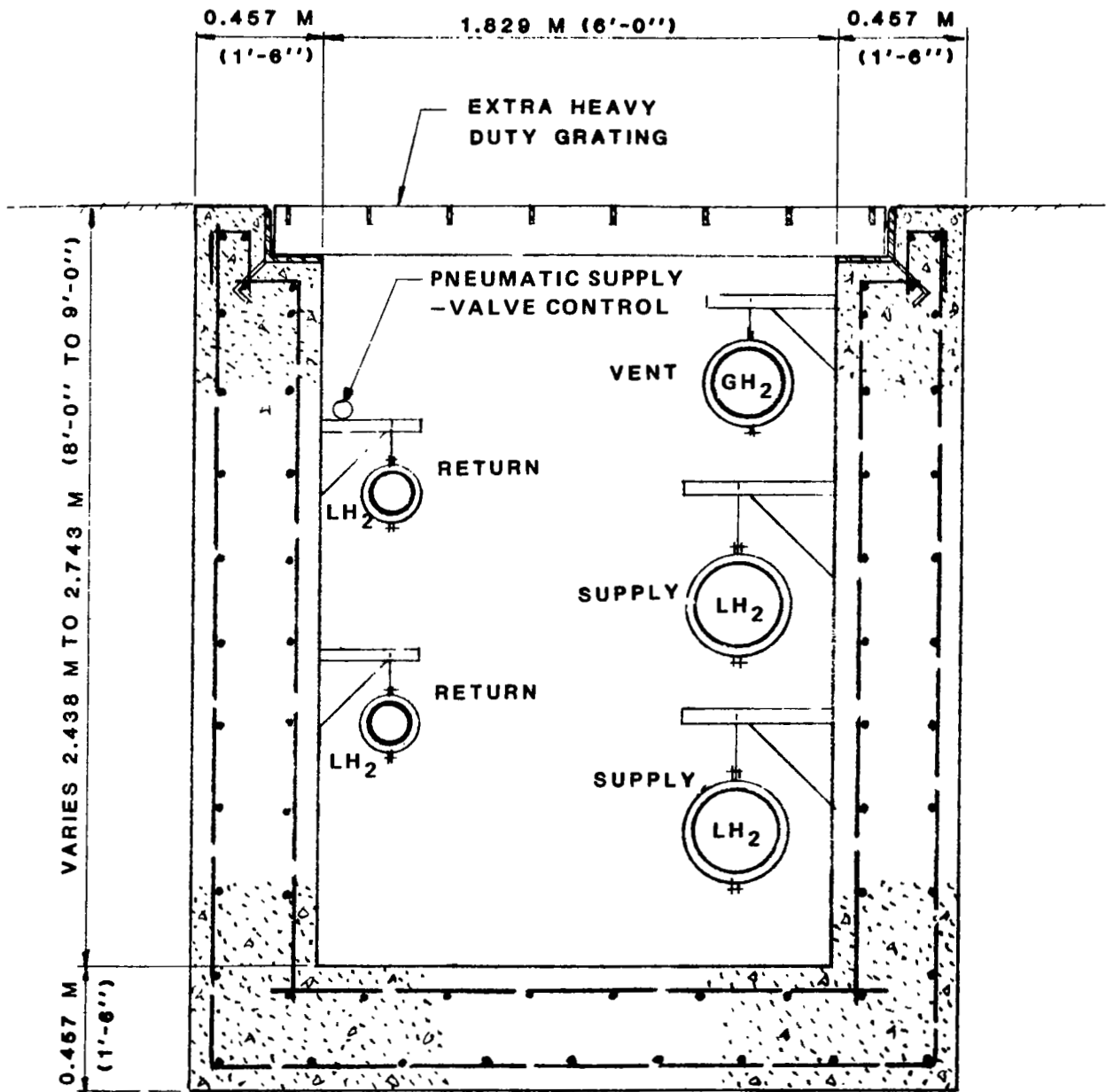

Figure 28. Typical Liquid Hydrogen Trench

extended to the limits of runway safety areas. However, there are portions of the trench between taxiways (and perhaps in the apron) where a significantly lighter grating design would appear to be acceptable. The marginal cost of the heavier grating, however, is relatively insignificant when compared to the increased safety provided by preventing an aircraft or heavy airport vehicle from entering the trench. The proposed trench design, therefore, reflects the use of heavy steel grating over the entire length of the distribution system.

Currently, there are no specific criteria governing the separation of the vacuum-jacketed pipe in the trench. For purposes of sizing the trench, a spacing of approximately one pipe diameter between adjacent pipes and between pipes and wall was assumed, based on access requirements for welding the conduit and jacketing. The regulations that will most certainly have to be developed for the future use of LH<sub>2</sub> will include appropriate criteria for spacing of LH<sub>2</sub> lines in the trench. The vertical pipe arrangement illustrated in Figure 28 is preferred primarily from the standpoint of minimizing the trench width.

Consideration will also have to be given to dewatering the trench, and it is suggested that dewatering at SFO will have to be accomplished by a pump system. Although water quantities to be handled are not significant, it is estimated that as many as six pumping stations may be required in order to avoid excessive trench depths, since trench sections in excess of 2.7 to 3.0 m (9 to 10 feet) in depth could encounter problems of uplift resulting from the high ground water conditions.

Construction scheduling and procedures will be critical to maintaining continuous and efficient airport operations during construction of the trench system. It is suggested that the development of a system of prefabricated trench sections with interlocking joints would result in minimum downtime for affected airfield facilities. This would also provide for continued terminal operations with a minimum of disruption. Trench construction can be expedited by employing high-powered concrete breakers and saws, (removing only the required quantity of pavement) trenching, and placing the prefabricated wall/floor sections and grouting them in place. A single runway would need to be out of service for no more than a few days with this system, and apron operations would not be disrupted excessively.

4.5.9 Hazards analysis. - An analysis of the general safety aspects of the airport liquid hydrogen systems is included in Appendix B of this report. A discussion of potential hazards related to the LH<sub>2</sub> distribution system and the resolution of these hazards follows.

Potential hazards result from a leak in or a failure of any LH<sub>2</sub> fluid system which could produce a spill of LH<sub>2</sub>. These systems include the LH<sub>2</sub> distribution loop piping and the hydrant fueler flex hoses, disconnect devices, and piping.

The extent of the hazard resulting from an LH<sub>2</sub> spill from the above systems is dependent not only on its proximity to aircraft, buildings, concentrations of people, etc., but also on the size and duration of the spill and whether the hydrogen ignites. Obviously, the greater the quantity that is spilled, the greater the hazard upon ignition, and the more rapid should be the response in terminating the LH<sub>2</sub> flow. Hydrogen has a very low ignition energy and will ignite more readily than other combustibles. Hydrogen also has very wide combustibility limits in air (4.1% to 74.2%). Consequently, it must be assumed that fire accompanying a spill will be the rule rather than the exception. On the other hand, an unconfined hydrogen-air mixture will ignite in a deflagration, not a detonation. This means there will be no blast damage. The resulting hydrogen flame is invisible and has a temperature of about 2255 K (3600°F). Despite the high temperature, the flame has a low emissivity and will radiate energy at a rate which is less than 10% of that from gasoline and other hydrocarbon fires. Radiation effects on nearby equipment and structures will not be as severe and clearances need not be as great. Also because of its high volatility, an LH<sub>2</sub> spill will vaporize very rapidly and the resulting fire will be approximately one-tenth the duration as an equivalent spill of hydrocarbon liquid.

4.5.9.1 LH<sub>2</sub> distribution system. - The potential for failure of the LH<sub>2</sub> distribution loop is minimal since the line is routed in a below grade trench with heavy grating cover, and the line is of double wall, all welded stainless steel construction. However, failures can be postulated. Failures need to be detected and immediate remedial action must be taken to prevent an incident. A single failure (leak) of the inner or outer line no matter how small will result in a rapid loss of the vacuum insulation. This will create a sudden increase in heat leak which in turn will cause a temperature rise of the fluid in the line. The instrumentation system will monitor circulating fluid temperatures, can initiate a system shut down, and can introduce a helium purge into the distribution system in the event that a liquid temperature rise indicative of a vacuum insulation loss is sensed. Thus the system would be secured to a safe condition when only a single wall of the double wall line has failed.

In the event of a complete rupture of the LH<sub>2</sub> distribution line such as might be postulated due to slippage along a fault line in an earthquake, a sustained loss of line pressure could serve as the signal to close the shut off valves located at the supply tanks. A suitable interlock would prevent nuisance shutdowns in the event of equipment or sensor malfunctions.

4.5.9.2 Hydrant fueler system. - Because of it's proximity to the aircraft and personnel, a failure of the hydrant fueler and it's requisite flex hoses and disconnect devices could be more significant. However, since the entire fueling operation is under operator surveillance and control, systems and procedures may be established to provide the necessary remedial action in the event of a failure. These would include a series of hydrogen leak detectors monitoring the disconnect devices at the pit, at the aircraft, and at the valves on the fueler vehicle. The annulus pressure of the various vacuum insulated pipes and flex lines would be monitored to provide an indication of pipe wall leakage. In addition the operator could be provided with an

emergency switch in the event he observed a system anomaly. Any of the above indications of system failure would initiate a shutdown of the hydrant LH<sub>2</sub> valve and the aircraft fill valve and introduce a helium purge into the system.

#### 4.6 Task 8: Aircraft Maintenance Requirements

While many operations and maintenance tasks for the LH<sub>2</sub> aircraft will be identical to those for Jet A-fueled airplanes, certain characteristics of the former point to significant departure from the techniques and procedures evolved over long periods. This task is intended to call attention to these characteristics and ways to alleviate what might become problem areas.

4.6.1 Changing of line replaceable units (LRUs). - Fuel system components in the LH<sub>2</sub> aircraft must be capable of being replaced without entering the tank or defueling to reduce aircraft maintenance time. This requirement also extends to sealing off the system to prevent admission of air to reduce the need for post-maintenance system purging.

There is considerable difference in the design state of the art between different types of currently used aircraft. A typical advanced boost pump for conventional fuel has a driving motor with a rotor or impeller contacting the fluid, and a housing incorporating an inlet check valve. The former can be extracted from the tank without defueling or admission of air to the system. The housing is left intact in the tank as the rotor is extracted from the housing, check valves closing off both the outlet and the inlet to prevent leakage of fuel through the housing. This can be done with a high degree of reliability and a minimum of fluid leakage. The same principal can be adapted to hydrogen components provided provisions are made to prevent contamination of the system.

Application of this design philosophy to other tank mounted components requiring maintenance will be essential to minimize the frequency with which the fuel tanks must be defueled and purged. Examples of such components are tank pressure regulators, flow control valves, and quantity indicating devices.

The design requirements for certain tank mounted components of the LH<sub>2</sub> airplane would be similar to those of current Jet A-fueled aircraft. Where such is the case, the replacement frequency currently experienced should be carried over to the LH<sub>2</sub> airplane provided that sufficient attention is given to the new operating environment. However, there may be some notable exceptions. For example, tank mounted boost pumps in current practice operate at constant speed. Fluid not required to satisfy the engine or engines being fed is either recirculated or simply not consumed by the engine. Such a design is incompatible with the requirement to minimize heat input to the fuel in the LH<sub>2</sub> airplane.

This suggests that the tank mounted boost pump system would require a means of modulating fuel delivered to essentially that required by the engine or engines being supplied. An attractive alternative would be to

insure that the pump pressure rise at low flow is high enough to prevent two-phase flow at the engine pump considering the line pressure drop and heat input.

Currently used tank mounted hardware has arrived at a high order of reliability as a result of a relatively long period of development and successful use. Many of these items have gone through periods when reliability was much poorer than that currently achieved and, in some cases, required relatively frequent tank entry for removal and troubleshooting. Such a process would be extremely expensive and time consuming were it to be repeated for tank mounted components in the LH<sub>2</sub> airplane. It will be essential that a very high level of development of all these items be carried out to assure satisfactory performance in aircraft to minimize service problems, particularly during early operation. As an example, failure of a screw in the level control valve of one current production aircraft has necessitated tank entry for correction. The cycle time required to defuel, warm-up, and inert; then to purge, purify, and refuel the aircraft LH<sub>2</sub> tanks after performing the repair makes it especially important to minimize or eliminate need for such effort. Many types of tank mounted components for the LH<sub>2</sub> aircraft will perform functions similar to those in Jet A fueled aircraft. Examples are fuel boost pumps, fueling control valves, fuel tank selector valves, fuel quantity probes, crossfeed valve, jettison or defuel pump, defuel valves, etc. The LH<sub>2</sub> components of course, will be operating in a new environment. There will also be a relatively large number of new components required. These include, but are not limited to, the following: vent float valve, vent three-way valve, tank pressure regulators, and fuel pressure relief valves. Adequate development of these or similar components will be essential.

Design attention must be given to the engine mounted heat exchangers to prevent freeze-up of the cooling media following engine shut-down. Otherwise the fuel must be shut-off prior to engine rundown to assure vaporization of the hydrogen in the heat exchanger. This is within the state of the art.

The current design concept reflects the requirement of separate tank or tanks for each engine with cross-feed capability. Adherence to this requirement increases the total number of tank mounted components which will be required in comparison to a simplified system in which one tank may be used to supply more than one engine. This has proved to be a very workable arrangement in certain aircraft and might provide an attractive degree of simplification in the LH<sub>2</sub> airplane.

Several factors causing problems in kerosene fueled aircraft, principally water and biological growth, will not be present and very high reliability should be possible.

A reliable fuel quantity indicating system is of great importance in the successful operation of any aircraft. In the LH<sub>2</sub> airplane, use of fuel

to balance the airplane will throw even greater burden on this system. The involved purging requirement for the LH<sub>2</sub> airplane requires that the probes or sensing elements be replaceable without opening or entering the tank.

With the added function of fuel location for balance control, it may also be desirable to include a backup indication of fuel quantity in the event of failure of the prime system. Although the backup system currently in use, drip (or dripless) sticks, would not serve this purpose, several alternate methods of gaging are available.

Successive purging with GN<sub>2</sub> and GH<sub>2</sub> of fuel lines or fuel system components opened in a maintenance dock would not seem to pose a significant problem since both materials would be available from central systems as described in Section 5. Since this problem is common to these and other extensively used cryogenic materials, adequate criteria and instrumentation for determining completion of purging have been developed and are readily available.

To meet the needs for similar purging of lines away from the maintenance dock, either at a line maintenance station or at a remote location at the maintenance base, it is believed that bottled GN<sub>2</sub> and GH<sub>2</sub> would provide the most practicable solution.

Use of helium may be a desirable alternate to successive purging with GN<sub>2</sub> and GH<sub>2</sub>, particularly at line stations where bottled gas will probably be used. Relative cost would be the controlling factor.

The need to provide for cryogenic fuel storage and adequate venting, possibly through a catalytic combustor, will complicate shop test and check-out procedures. However, there is some compensating benefit from testing at the same temperature experienced in flight. It will be relatively simple to duplicate the flight pressure condition as well.

If isolation of such facilities, particularly in a separate building, is required, parts cycle time will be increased together with facility cost and spare parts ratio. Such separation of rework and test locations is undesirable and might result in a separate shop facility for LH<sub>2</sub> components.

4.6.2 Inspection, maintenance and repair of tank and insulation systems. - The comments of this section relate to integral LH<sub>2</sub> tank construction. It is assumed that during the early operation of the LH<sub>2</sub> aircraft rather frequent inspection of fuel tank structure would be required on a sampling basis. As experience is gained, reduction in inspection frequency will follow. During this time the impact of thermocycling and operating in the cryogenic environment will be explored and the allowable time between inspections increased as confidence is gained in operating practices.

It is believed that nominal inspection frequency of the inside tank structure at 4000 hours is more realistic than the 8000 to 10 000-hour period suggested (Ref. 2). Current practice for Jet A-fueled aircraft requires external structural inspection at nominal 3600-hour intervals,



after considerable maintenance history, with approximately 20 percent sampling inspection internally at 20 000 hours. In view of the fact that the external tank surface of the LH<sub>2</sub> airplane will not be available for inspection, it is considered likely that continued internal inspection will be required at something on the order of 4000 hours. It seems reasonable that X-ray or other nondestructive testing of the high stress points will be required on something between 20 percent and 100 percent of the fleet at the nominal frequency of 20 000 hours. Such inspection techniques for high stress areas should be investigated early.

It appears mandatory that inspection and repair techniques for the insulation and shroud materials be developed and available when the airplane is placed in service. It is certain that these techniques will be needed and they should be available when required.

It is anticipated that the composite interconnect truss structure will require close surveillance, particularly in the bearing areas. Adequate inspection capability, and easy replacement of these members would appear to be required.

Control system routing and inspection capability in the vicinity of the fuel tanks would appear to present critical design requirements. The cryogenic environment with exposure to insulation breakdown, etc., may present maintenance problems if not adequately handled by design.

4.6.3 Handling of hydrogen aircraft in a maintenance hangar. - Since the vented GH<sub>2</sub> can be handled safely by simple diffusion into the atmosphere, with adequate attention to prevent H<sub>2</sub> accumulation in a structure, the question of optimum handling of tank boil-off in the hangar becomes an economic issue. Analysis suggests that the best solution depends on the occupancy factor, defined as percent of time a maintenance dock is occupied. The solution for a major maintenance facility with an occupancy factor as high as 60 percent would not apply to a line station with an occupancy factor of 10 percent or even less. For the former, potential savings of GH<sub>2</sub> would warrant investment in a recovery system. For the latter, the possible capital expenditures which can be justified are limited. The trade-off will depend on the future cost of GH<sub>2</sub>.

4.6.4 Maintenance facility. - The boil-off handling problem in a major maintenance facility or maintenance base can be divided into two categories. Routine checks and maintenance work will normally be done with the airplane in rather precisely located position so that the envelope of possible tail vent locations is rather small for a given model of aircraft. This is estimated at ±8 inches laterally and ±3 inches longitudinally; hence the problem of providing a flexible connection to the vent discharge is relatively simple. After collection of the GH<sub>2</sub>, either:

- a. use of a catalytic combustor, (Reference 2, p. 4-14, approach a)

- b. delivery to pipeline for recycling through a liquefaction plant, (approach b)
- c. discharge to outside atmosphere, (extension of approach c).

are alternate courses. The choice of disposal mode depends largely on the cost of moving the  $\text{GH}_2$  from the facility to the liquefaction plant. Considering the rather modest potential savings, it would appear that the maximum length of collecting pipeline would be limited to a very few miles, probably order of 2.

At other locations where casual work may be performed but where precise aircraft positioning is not normally practiced, the size of the vent envelope possible will be significantly increased and installation of a  $\text{GH}_2$  collecting system will be more difficult to justify. Here the increased cost of the facility and the reduced occupancy factor for any one airplane position will combine to make collection of the  $\text{GH}_2$  less attractive. In such cases, overboard venting or aircraft positioning with the vertical tail outside the hangar may be attractive. Catalytic combustion in place is also a possible solution.

For maintenance work where aircraft tanks must be entered, defueling, inerting, and warm-up could be accomplished as described in Section 4.5.5 at a defueling facility. After delivery of the aircraft to the maintenance hanger the tank would then be charged with air using air movers of the same type as presently employed with Jet A-fueled aircraft. Completion of this phase would be signaled by reaching the OSHA minimum limit for oxygen concentration using currently available instrumentation.

Following completion of the maintenance tasks, the tank would be closed and the aircraft returned to the fuel/defuel facility. There the purification, chill-down, and refueling part of the cycle described in Section 4.5.5 would be performed.

The question as to whether  $\text{LH}_2$  fueling and defueling can be permitted in a maintenance dock, without requiring removal of the aircraft to a separate fuel/defuel facility will have a significant impact upon airplane out-of-service time for maintenance. If it is necessary to delay checkout of the fuel system until the airplane is dedocked, then purged, cooled down, and fueled, extensive delays in return to service could result. If problems are encountered requiring re-entry of the fuel tanks, out-of-service time for major maintenance could be significantly increased. Considerable variability is expected in the cycle time to defuel, inert, warm-up, purge, cool-down, and refuel the airplane depending upon insulation condition and tank and vent size. This time could be expected to run from a minimum of six hours to as much as 18 hours. Additional maintenance time of this magnitude would be a severe economic penalty for any operator.

It is the practice of at least one major airline to fuel the aircraft and begin fuel system check-out on the third day of a five-day overhaul. Other operators use a check-out solvent for this purpose at about the same time. It would be highly desirable to maintain this capability in the LH<sub>2</sub> aircraft if possible. Almost any precautions as far as roof venting and airplane placement in the dock would be preferred to losing it. A detailed analysis of the operations which would be involved, the hazards which may be encountered, and the economics of options which exist is recommended as a subject for separate study.

4.6.5 Line maintenance stations at SFO. - It is industry's experience that the occupancy factor for large wide-bodied aircraft stations away from the major facilities is so low that no attempt to recycle GH<sub>2</sub> would appear justified. The occupancy factor would be expected to be of the order of 10 percent at such locations. Because they are so little used, it is assumed airline line maintenance facilities at SFO would be located some distance from the liquefaction plant. Therefore, potential savings from recapture could not justify capital cost of constructing the GH<sub>2</sub> vent return system.

Defueling of aircraft requiring tank entry at a Line Maintenance Station would normally be done at the defuel/refuel facility near the liquefaction plant, or, in the case where small quantities of LH<sub>2</sub> are involved, into a mobile transporter. The purging operation would be comparable to that prescribed for the maintenance facility section, although with some significant differences. All major line maintenance stations are presumed to have LN<sub>2</sub> systems. GN<sub>2</sub> could be drawn from this system. Air moving equipment would also be available and instrumentation used would be comparable to that described in the Maintenance Facility Section.

Supply of GH<sub>2</sub> for the final purging step is another matter, however, and would be expected to present a greater problem. It appears that the best solution would be to draw GH<sub>2</sub> under pressure from the remaining aircraft tank which had not been defueled. Obviously, this would not provide a solution in the event that it were necessary to work on both tanks concurrently. If this were the case, it would appear that the best solution again would be use of a mobile transporter, or to tow the aircraft to the Defuel/Refuel facility.

4.6.6 Impact of hydrogen on normal routine maintenance of other aircraft systems and equipment. - If any hydraulic components or lines will be within communicating distance of the hydrogen tanks, it is mandatory that the hydraulic fluid used and the fuel tank insulating material be completely compatible to avoid significant problems arising from inevitable spillage or leakage of hydraulic fluid in or on the insulating material. It would appear that all of the various courses of insulating material must be resistant to hydraulic fluid, not merely the outer courses or protecting membrane.

The complete elimination of mechanical refrigeration for cooling compressor bleed air for the passenger and crew compartment ventilating air

supplies will provide a significant bonus provided the added heat exchanger is adequately developed prior to scheduled service. A high order of development of this equipment will be essential to ensure satisfactory operation.

The double wall, vacuum insulated tank-to-engine LH<sub>2</sub> lines could be potentially troublesome, particularly at flex-joints required to control thermal expansion and structural deflection. Instrumentation will be needed to indicate loss in vacuum resulting from line failure. If integrity of the vacuum jacketed LH<sub>2</sub> fuel system appears to be a problem, line location permitting ready visual inspection for evidence of frost accumulation would be important. Access openings in the fuselage LH<sub>2</sub> line run areas and routing in the wing aft of the rear spar out to the engines appear desirable. Fuel line location relative to structure, control lines, and to other lines such as hydraulic and engine bleed could become a problem after loss of vacuum insulation and lines approached cryogenic temperature. Thermal gradients could become very great for certain systems, such as an engine bleed line for example.

Aside from safety aspects associated with leakage, maintenance of other structure and systems could be adversely affected if material choices are made without considering the possibility of hydrogen embrittlement.

#### 4.7 Task 9: Airline Ground Support Requirements

This task addresses the various problems of supporting the subject LH<sub>2</sub> fueled aircraft at the terminal. Secondary logistic problems peculiar to the two particular aircraft chosen for this study - two passenger decks, internal or external fuel tanks, and flight station remote from the passenger compartment - are also discussed.

Of the four possibilities for fueling the aircraft presented in Task 4 - (1) the gate position as done today; (2) gates physically removed from the terminal possibly having structural protection for the terminal; (3) fueling in isolated locations but relocating the aircraft for servicing at the terminal; or (4) fueling and servicing in isolated locations and transporting the passengers to and from the terminal - the first, fueling at the gate, precludes many operational difficulties. Additional facilities, manpower, and equipment which would be required by remote fueling systems are not needed. For these and the other reasons discussed in Task 4, ground service considerations are based on the premise that the airplane is parked at a conventional gate position interchangeable with conventionally fueled aircraft.

Ground servicing times are critical in airline operation to keep tight schedules. It is crucial that fueling be done in an expeditious manner concurrent with other required servicing. Accordingly, the subject LH<sub>2</sub> aircraft must preserve the capability of current, conventional aircraft, viz., that when being fueled, other required services can be performed simultaneously, and in about the same time frame. This capability is so imperative it is recommended that an exhaustive study of ground handling and service methods be made to achieve the highest level of service and economy.

It is stressed that during some interim time period both Jet A fueled aircraft and LH<sub>2</sub> fueled aircraft will be in the same fleet, and that occasionally one type will be substituted for another.

For reference, at the present time a major carrier at San Francisco has 87 passenger flight departures a day using 737's, 727's, DC-8's, DC-10's and 747's. The following ground times are realized with these aircraft:

<u>% Of Arrivals</u>	<u>Turnaround or Through Flights - Time on Ground</u>
39.4%	45 minutes or less
58.7%	60 minutes or less
68.7%	70 minutes or less
80 %	80 minutes or less

Only 19.2% of the fleet require ground times of more than 80 minutes.

Figures 29 and 30 show contemporary and desired service times for future aircraft for Through-Stop and Turn Around Stations.

Figure 31 is an illustration of the various kinds of vehicles and services which are currently used in connection with gate operations for current Jet A-fueled wide-bodied aircraft.

It is most desirable to have facilities and equipment as interchangeable as possible within a particular airline operation. Normally, gate positions are permanently assigned or leased by the carrier. The versatility of these gates and associated ground support equipment to handle all type aircraft within the fleet interchangeably enhances the operation's economy by minimizing the number of pieces of equipment, the number of operators, and the actual physical area to park equipment.

In order to minimize manpower, ground equipment, and required ramp area for parking ground support equipment, more and more aircraft services are being provided by underground systems. By 1985 most gates at SFO will have hydrant fuel, 400 cycle power, pneumatic power and, possibly, potable water provided by ramp connections. Lavatory service, conditioned cabin air, and other services are being considered.

Other considerations regarding anticipated support of aircraft in the future will include requirements existing and expected of the various safety and ecological organizations, i.e., Occupation and Safety Health Act (OSHA), Environmental Protection Agency (EPA) and the California Air Resource Board.

At the present time airline fleets are made up of what are termed narrow body aircraft - 727's, 707's, DC-8's; and wide body aircraft - L-1011's, 747's, DC-10's, etc. The aircraft which were specified for use in the subject study are both double-decked, 400 passenger configurations.

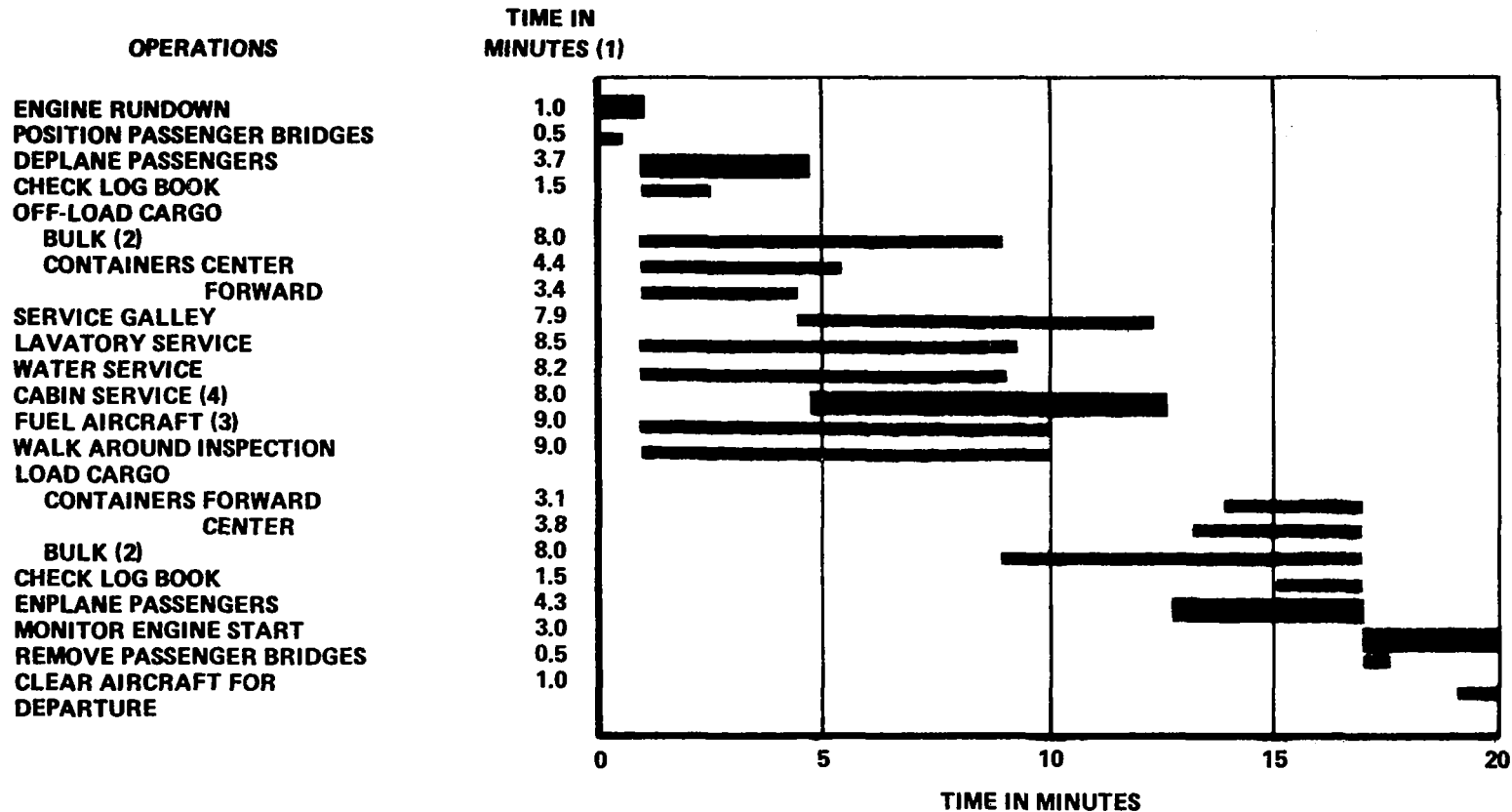

- CRITICAL TIME PATH
- (1) TIME INCLUDES EQUIPMENT POSITIONING & REMOVAL
- (2) TIME AVAILABLE FOR BULK LOADING
- (3) 1600 GPM INITIAL PUMPING RATE
- (4) CABIN TIDIED BY STEWARDESS
- MIXED CLASS CONFIGURATION
- 26 FIRST CLASS
- 122 TOURIST CLASS
- 55% LOAD FACTOR

Figure 29. Terminal Operations: Through-Stop 650 Nautical Mile Stage Length

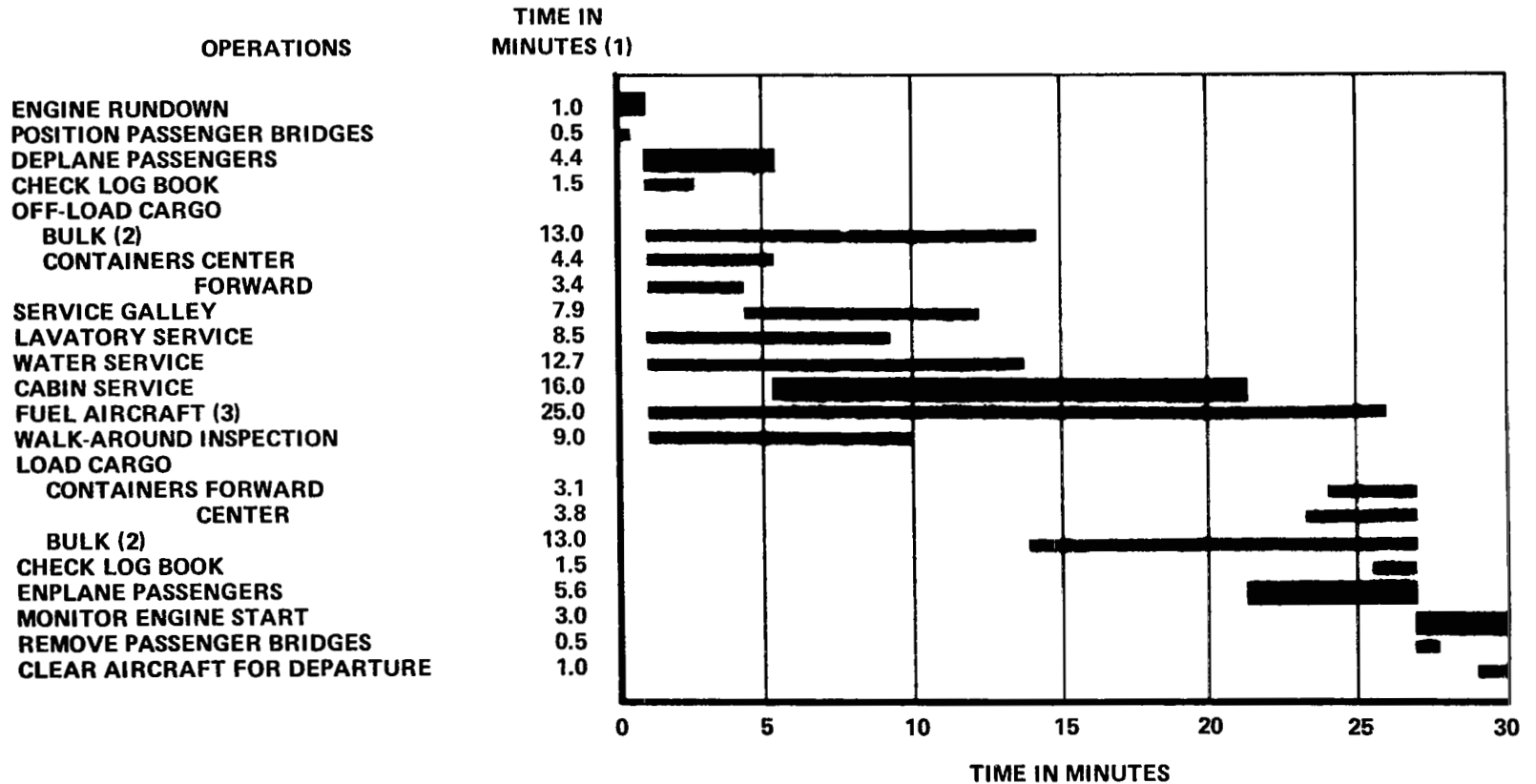

■ CRITICAL TIME PATH  
 (1) TIME INCLUDES EQUIPMENT POSITIONING AND REMOVAL  
 (2) TIME AVAILABLE FOR BULK LOADING  
 (3) 1600 GPM INITIAL PUMPING RATE

● MIXED CLASS CONFIGURATION  
 ● 48 FIRST CLASS  
 ● 222 TOURIST CLASS  
 ● 100% LOAD FACTOR

Figure 30. Terminal Operations: Turnaround Station 5000 Nautical Mile Stage Length

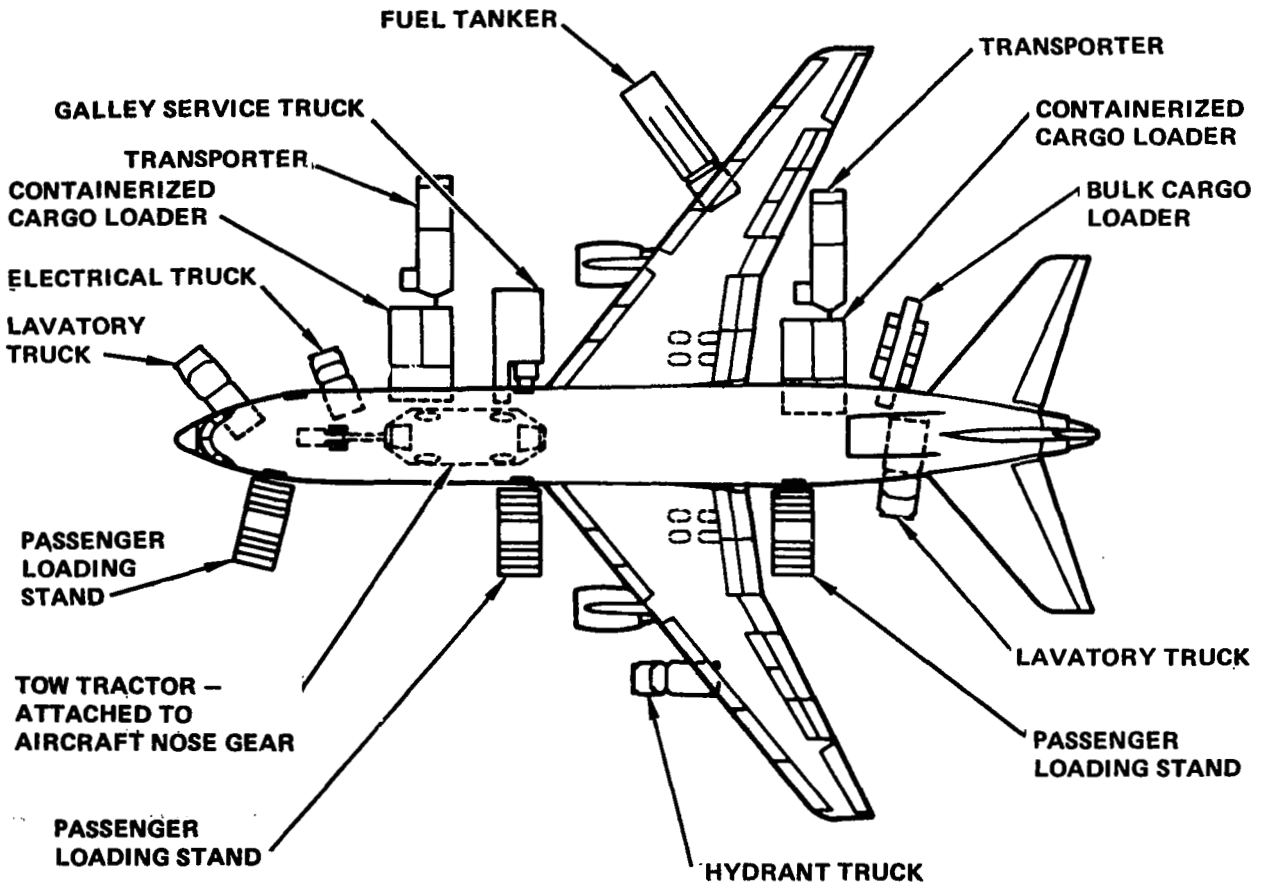

Figure 31. Terminal Servicing Equipment for Current Jet A-Fueled Aircraft



To date there have been no two passenger deck aircraft; consequently, no gate facilities or ground support equipment has been developed for this type airplane.

Projected airline industry growth through the 1990's appears to indicate little need for aircraft of larger passenger capacity. If this projection is valid there may not be a requirement for many 400 passenger, double deck aircraft. In this event, direct operating cost would be adversely affected if specialized, double-deck type ground support equipment and facilities had to be provided for only a few aircraft. Such equipment would therefore be kept to a minimum.

However, if fuel availability and operating economy establish the double-deck LH<sub>2</sub>-fueled aircraft in the industry, new support equipment as required to allow the airplane to fulfill its mission efficiently must be provided. Inevitably, as many LH<sub>2</sub>-fueled aircraft support requirements as possible will be handled by existing ground support equipment to minimize capital expenditure by both airports and airlines.

The following section discusses facility and equipment requirements which would stem from introduction of the subject LH<sub>2</sub> aircraft into service at SFO.

#### 4.7.1 Facility and equipment requirements

4.7.1.1 Passenger enplanement. - The masterplan for San Francisco International Airport after 1985 shows all gate positions provided with jetways which are designed for servicing one passenger deck. The boarding level at San Francisco is 5.2 m (17 feet) from the ground. The subject airplanes have a lower passenger deck at 5.08 m (16 feet 8 inches), positioning the jetway for that deck nearly horizontal during servicing.

The two passenger deck aircraft can be introduced without facility modification by using the in-plane stairways. Passengers assigned one level would board through an assigned jetway; those on the other level, through the second jetway. This would minimize confusion in the aircraft door/stairway area. Consideration would be given elderly, crippled, heavy laden, and other partially incapacitated passengers by assigning seating in the most easily reached area.

Because the flight deck is separated from the passenger compartment on the internal fuel tank aircraft, it will be necessary to provide cockpit access either by means of an appendage on the facility or by ground support equipment. Similar equipment is currently available for wide body aircraft; consequently, the requirement poses no particular mechanical problem. However, when the plane is at the gate, this extra equipment adds to the congestion.

4.7.1.2 Baggage loading and unloading. - The proposed aircraft has a pre-load container system similar to that currently used on wide body aircraft. The containers are designed to be interchangeable with those now in service

to insure ease of baggage and cargo transfer between different model wide body aircraft. Since preloaded container doors are similar in configuration and sill heights do not exceed those now in use (max DC-10 is 2845 mm (112 inches); less for L-1011 and 747), existing loading equipment can therefore be expected to be used.

Similar considerations apply to the bulk pit baggage doors so standard belt loaders can be used.

4.7.1.3 Lavatory service. - Presently, all narrow body and wide body aircraft have their lavatory ground service panels within 2.44 m (8 feet) of the ground with the exception of the 747 which has one aft location 4.57 m (15 feet) from the ground. This one particular panel requires a special lift for positioning the operator close enough to service the airplane. The LH<sub>2</sub>-fueled aircraft can be designed so lavatories can be serviced with standard equipment.

4.7.1.4 Galley service. - Contemporary wide body aircraft are normally fitted with removable food and liquor modules in their galleys. These aircraft can be purchased with galleys located either on the passenger deck or below in the preloaded container baggage section. Narrow body aircraft always have galleys located on the passenger deck, but some of these aircraft are fitted with large, preloaded, dolly movable modules while others use many small "picnic basket" type, hand carry-on containers.

Wide body aircraft are serviced by three type food trucks; 1) a large van having a roller mat floor with a conventional scissor lift to position the van at the passenger level galley service doors; 2) a special module handling unit that operates adjacent to the lower lobe container loader from which those galleys are serviced; and 3) a unit similar to (1) above having a fold-down solid floor over the roller mats capable of servicing galleys in all model aircraft. The latter, the universal type food truck, sacrifices somewhat in economy of manpower, service times, and maneuverability. However, the unit is ideally suited where a mixture of aircraft require servicing, generally at smaller stations. Because of the height and weight involved in the scissors lift units, it is necessary to provide stabilizing devices on the chassis as the van sides expose a large area to prevailing winds and jet blasts. The jet blasts, often to velocities of 145 km (90 mph), have the potential of tipping over high lift equipment.

The double-decked LH<sub>2</sub>-fueled aircraft can be designed so food service can be provided either at the lower level, or to a below-decks galley. Elevators within the aircraft would then be used to move the supplies to the upper deck.

4.7.1.5 Cabin service truck. - Special trucks are required for servicing aircraft cabins to provide the supplies of fresh linen, literature for the seat pockets, and necessary equipment for cleaning carpets, ash trays, seats, etc. These units are generally operated from the side of the aircraft opposite the jetway. The present wide body cabin service supply truck would

probably service the lower deck of the LH<sub>2</sub>-fueled aircraft. However, either an appendage would have to be added to this unit to gain access to the upper deck or else a specialized piece of equipment would have to be designed. The present design, similar to a food truck, lifts a 6.1 m (20 foot) van to the passenger deck by means of a scissors lift. The additional height requirement for the upper deck of the LH<sub>2</sub>-fueled aircraft will require a larger, more expensive unit.

The present van and crew size allocated normally clean the cabin in the desired service times. Consequently, any new design should be predicated on the equivalent allocation of supplies and personnel. Many of the present units are equipped with a 5kW engine-driven generator to provide power for cleaning chores when ship power is not available.

4.7.1.6 Aircraft towing. - Tow tractors are available to handle aircraft up to one million pounds gross weight. These machines are low in profile 1.58 m (62 inches) and can maneuver under the aircraft quite easily. The aircraft is generally moved by connecting a tow bar to the front of the nose wheel. At crowded gate positions the tractor can be positioned behind the nose wheel permitting a tow bar connection where the aircraft can be pulled back from the terminal (see Figure 30).

The nose wheel tow bar attach points on the LH<sub>2</sub> fueled aircraft should be of the same design as contemporary aircraft allowing standard tow bars to be used interchangeably. Future models of tow tractors may have the capability of towing the aircraft at normal taxi speeds 48 to 56 km (30 to 35 mph) for moving to and from the runway. Normal tow speeds are now about 10 km (6 mph).

4.7.1.7 Other required support equipment. - Water service can be provided in conjunction with galley servicing by addition of a potable water tank to the food truck, by a separate water service vehicle, or by a ramp or jetway service fitting.

An APU is included as standard equipment aboard the study airplanes. Present day airline operation endorses this concept as it lends versatility to the aircraft in the charter stations it can visit and minimizes the size of crews for ground support. Normally the APU provides 400 Hz power and pneumatics for cabin air conditioning and engine starting. However, the subject LH<sub>2</sub>-fueled aircraft will not require that amount of power for air conditioning because of the simple, nonmechanical refrigeration system which will be employed. This will provide significant advantage, not only in reduced energy but also in noise reduction at the airport.

#### 4.7.2 Special equipment required for LH<sub>2</sub> aircraft

4.7.2.1 Hydrant service vehicle. - Location of the fueling connection in the tail cone provides the best situation considering safety aspects and correlation with other ground service activities which will be performed concurrently with fueling. The hydrant service vehicle and associated plumbing should be sized to be capable of on-loading the mission fuel in the

allocated service time as indicated in the introductory paragraphs of this section. Other details of the fueling unit are discussed in Task 4. It is anticipated topping-off will be done with this unit in the event of a delay, mission change, or final fuel load change.

4.7.2.2 Defueling equipment. - In the event of a delay over six hours aircraft are normally removed from the gate. The maintenance facility could be used for the occasional requirement for defueling LH<sub>2</sub> aircraft. A mission change to a lesser distance or required fuel load is infrequent enough that the expense of special defueling equipment at the ramp could not be justified.

4.7.2.3 Leak detection equipment. - GH<sub>2</sub> can be detected readily. If there are detectors installed on the line vacuum pumps and in the areas around the fuel tanks, no other equipment appears necessary.

#### 4.7.3 Effect of aircraft configuration on maintenance and support requirements

4.7.3.1 Physical access between flight station and passenger compartment. - The internal tank aircraft has the flight deck separated from the passenger compartment by the forward fuel tank. Specific ground handling problems associated with this configuration include a means of crew enplaning and deplaning. As considered in NASA CR 132559, both lavatory and galley provisions will be made available to the flight deck and will require corresponding support equipment. These items are mentioned in Section 4.7.1.1.

In current aircraft it has been found desirable that a qualified person (normally a member of the flight crew) be available for special service from time to time in the passenger compartment. Flight logs show various reasons as follows:

- a. Fire in waste containers of galleys and lavatories.
- b. Observe certain features of the aircraft during daylight hours.
  - 1) Spoilers
  - 2) Flaps (trailing and leading edge)
  - 3) Ailerons
  - 4) Engine reversers.
- c. Mechanical and electrical problems in galleys and lavatories.
- d. Quiet violent or drunk passengers.
- e. Observe main gear-down locks.

Since none of these functions require flight training, it is concluded that presence of a member of the flight crew, per se, is not required. Alternatively, a senior member of the cabin crew of the LH<sub>2</sub> aircraft could receive special instruction for these emergencies and could serve as the flight captain's representative in such situations.

4.7.3.2 External tank aircraft. - The fuel tanks on the wing in the external tank configuration pose several problems. First, access to the aft passenger door by a jetway becomes exceedingly difficult without a design modification. Secondly, there is greater exposure to damage of the external tanks by ground vehicles as the tanks project beyond the leading and trailing edges of the wing. Lastly, general opinion among airline operators is that the presence of the external tanks obscure the passenger's view, sought by some, and highlight to other sensitive passengers that they are in a different type aircraft, leading to uneasiness and dissatisfaction.

## 5. PHASE III - CONCEPT DESCRIPTION

Preceding sections have described the basis for establishing the requirements for LH<sub>2</sub> fuel at San Francisco International Airport (SFO) to permit its use in long range transport aircraft in 2000 A.D. The facilities and equipment needed to liquefy hydrogen, and to store and dispense it in accordance with postulated airline requirements at SFO, have also been described.

In this section the selected arrangement for these facilities and equipment, and the associated operating procedures, are described. In addition, changes in design of the preferred LH<sub>2</sub> fueled aircraft which has been used as a model for this analysis are suggested. The changes resulted from consideration of the handling and operational procedures which were found to be necessary or desirable in the use of LH<sub>2</sub> fuel.

### 5.1 Task 10: Concept Arrangement and Description

The following narrative and illustrations summarize the work of Tasks 2 through 9 to depict a concept for converting San Francisco International Airport to accommodate limited use of LH<sub>2</sub>-fueled aircraft. The objectives of Task 10 were to: 1) describe a workable concept, 2) gain insight into the costs of adapting and operating the airport, and 3) provide a preliminary assessment of the problems or difficulties likely to be encountered in such a project. The concept is not represented as an optimum solution; in fact, as the concept developed, decisions were occasionally made which offered opportunity to explore more fully the potential difficulties, rather than to develop the simplest solution.

5.1.1 Description of selected concept. - The physical alterations to the airport and its environs and the principal impacts on operations are described in this section. Section 5.1.2 discusses cost implications and Section 5.1.3 summarizes the requirements for facilities and equipment unique to the LH<sub>2</sub> aircraft.

5.1.1.1 Fuel demand and energy supply. - Task 2 developed an estimate of the 1995-2000 route segments that would be potential users of the designated LH<sub>2</sub> aircraft. A scenario was developed relating probable development programs and early production of the aircraft to priority city pairs and routes including SFO. Using extrapolation of current service patterns at SFO, a schedule for an average day in the peak month of the year 2000 was postulated

for the LH<sub>2</sub>-fueled aircraft. The schedule serves thirteen destinations with 70 flights operated by eight carriers, and represents about 41 percent of enplanements on CAB certificated services (excluding intrastate boardings).

Trip fuel requirements for the schedule were aggregated at approximately 7.68 kg/s (731.4 tons per day) (net fuel to engines). Refueling schedules were derived based on a fueling rate to accomplish design mission fuel transfer in 38 minutes, commensurate with current procedures.\* This exercise produced refueling times ranging from about eight minutes for a Kansas City service to 31 minutes for a Tokyo flight. The demand schedules indicated that no more than four aircraft would need to be fueled simultaneously.

An evaluation of alternate supply methods in Task 3 concluded that the on-site liquefier offered the most attractive economics. Production of nearly 8.888 kg/s (846.5 tons/day) of the liquid is required to supply the 7.68 kg/s (731.4 tons net fuel to the engines. To meet this requirement, four 2.625 kg/s capacity modules are programmed for the concept, providing some reserve capacity (see Task 6). The gaseous hydrogen supply to the plant is assumed to be provided from a nearby pipeline. For convenience, the GH<sub>2</sub> supply line is assumed to enter the airport site from a causeway constructed across the seaplane harbor.

During peak periods, all four modules will be producing LH<sub>2</sub>, consuming nearly 332 megawatts of electrical energy. For purposes of concept development, it has been assumed that the power is obtained commercially and can be furnished from the easement along the Bayshore freeway now traversed by high capacity transmission lines. Access to the airport LH<sub>2</sub> liquefaction plant would be over the causeway as shown on Figure 32.

5.1.1.2 Liquefaction plant and storage facilities. - The site selected for concept development of the liquefaction and storage facilities is an unused plot on the bay side of the airport. The plot, of about 174,000 m<sup>2</sup>, is located between a large area currently used by American Airlines for maintenance facilities and two smaller plots used by a fixed base operator and UAL, respectively. Access is currently via a perimeter roadway serving several leaseholds around the seaplane harbor.

Liquefaction plant, substation, storage facilities, maintenance yard, and administration require approximately 202,000 m<sup>2</sup>. The Defuel/Refuel Apron and related facilities require about 52,600 m<sup>2</sup>. The concept illustrated in Figures 32 and 33 adapts the plant and storage layout of Task 6 to the selected plot. Twenty acres of land are to be reclaimed adjacent to the site in the shallow seaplane basin, to provide the necessary 255,000 m<sup>2</sup>. Minor liberties were taken with the property subdivision line on the west edge of the plot to simplify layout.

---

\*It was subsequently pointed out that for future designs airline preference is to reduce the design mission refueling time to 30 minutes.

The airport perimeter road will be relocated to the outer edge of the landfill to maintain access to the American facility. The road will join the causeway envisioned across the old seaplane basin from the peninsula, in the area of the existing fuel storage facilities, to provide direct vehicular access to the site and a route for the LH<sub>2</sub> supply and power transmission lines.

The operation of the liquefaction plant is described in Section 4.4. Gaseous hydrogen feedstock enters the plant from the causeway and is introduced into the H<sub>2</sub> feed compressors. From there it goes through purification, recycle compression, liquefaction, and is then stored in five 3785 m<sup>3</sup> (1 000 000 gal) vacuum-jacketed spherical vessels. Air separation facilities are provided to supply liquid nitrogen needed as a heat sink in the H<sub>2</sub> liquefaction process.

The LH<sub>2</sub> storage tanks are located along the eastern edge of the site and the LH<sub>2</sub> distribution system to the passenger loading terminals leaves the site at this point. Aircraft access to the apron area is via Taxiway "C". A parking and service area for the hydrant fuelers and LH<sub>2</sub> tanker trucks needed for special fueling service in maintenance areas is adjacent to the apron, as these vehicles require direct access to the aircraft pavements.

Existing landfill in the area is probably not suitable for founding many of the elements of the plant. Piles will be required for these facilities, as is common for most of the buildings at the airport.

5.1.1.3 Gate fueling. - Consideration of the location and nature of the aircraft fueling operation is fundamental to the identification of a feasible concept for LH<sub>2</sub> aircraft/airport integration. Task 4 presented an evaluation of alternative fueling procedures and selected the terminal gate procedure as most appropriate for SFO. This concept is depicted in Figures 32 and 33.

The fueling operation will be performed at the terminal gate by a fueler vehicle (Figure 17) providing the necessary interface between a hydrant point of supply and the aircraft fuel system. It has been generally concluded that fueling of LH<sub>2</sub> aircraft at the gate will not seriously alter ground servicing procedures or times, relative to current wide-bodied aircraft. However, development of an optimum ground service operation will require a much more definitive analysis of the possibilities which exist than time has permitted in the present study.

5.1.1.4 Distribution system. - In Task 4 it was determined that 19 of the 81 terminal gates planned at SFO will be required to serve LH<sub>2</sub>-fueled aircraft. This requirement was established by translating the LH<sub>2</sub> schedules produced in Task 2 into gate demand by individual carrier. The gate positions which were assumed for purposes of defining the LH<sub>2</sub> distribution route are shown on Figure 33 as the darkened airplane outlines. Designation of these facilities by air carrier is shown on Figure 32.

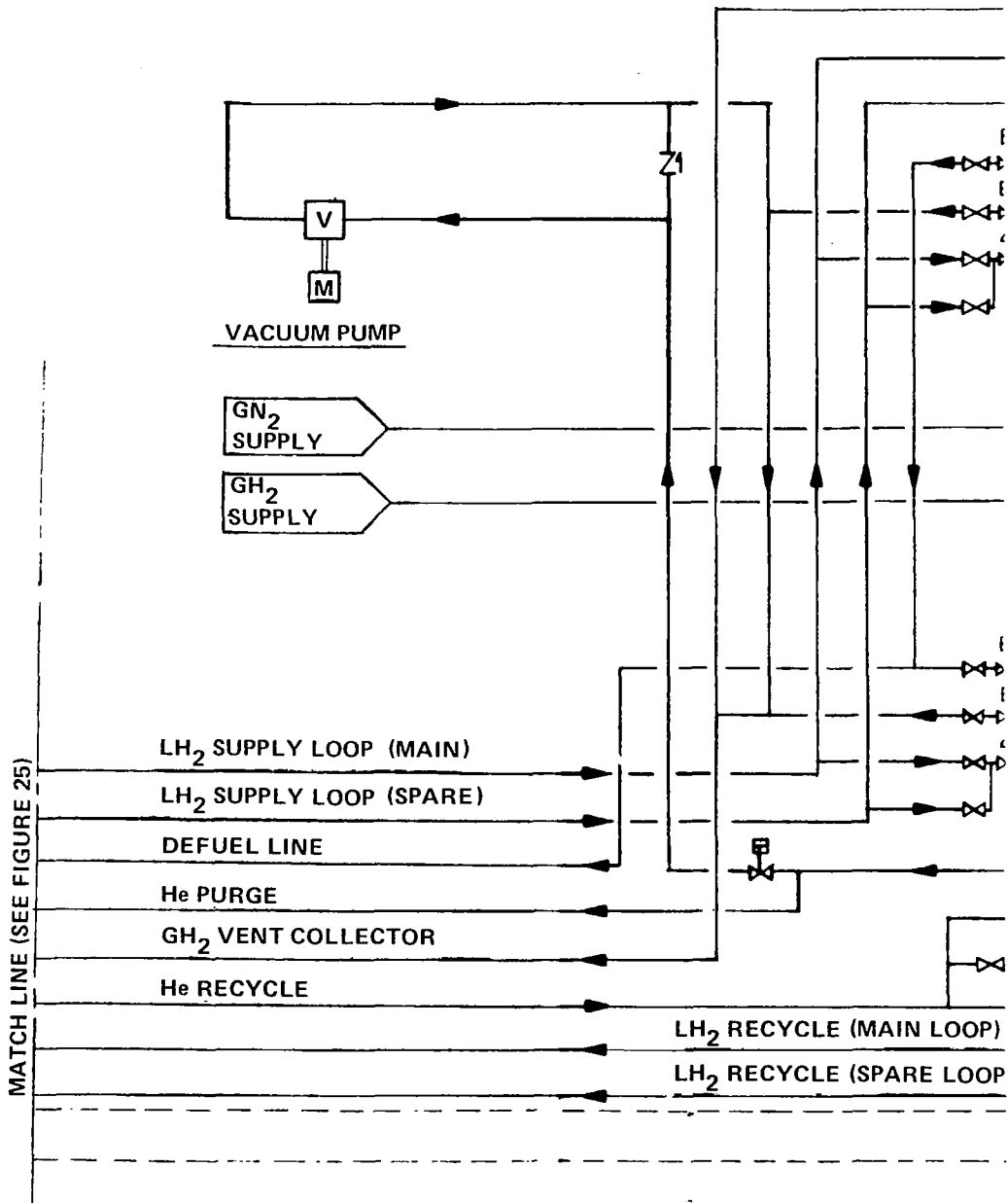



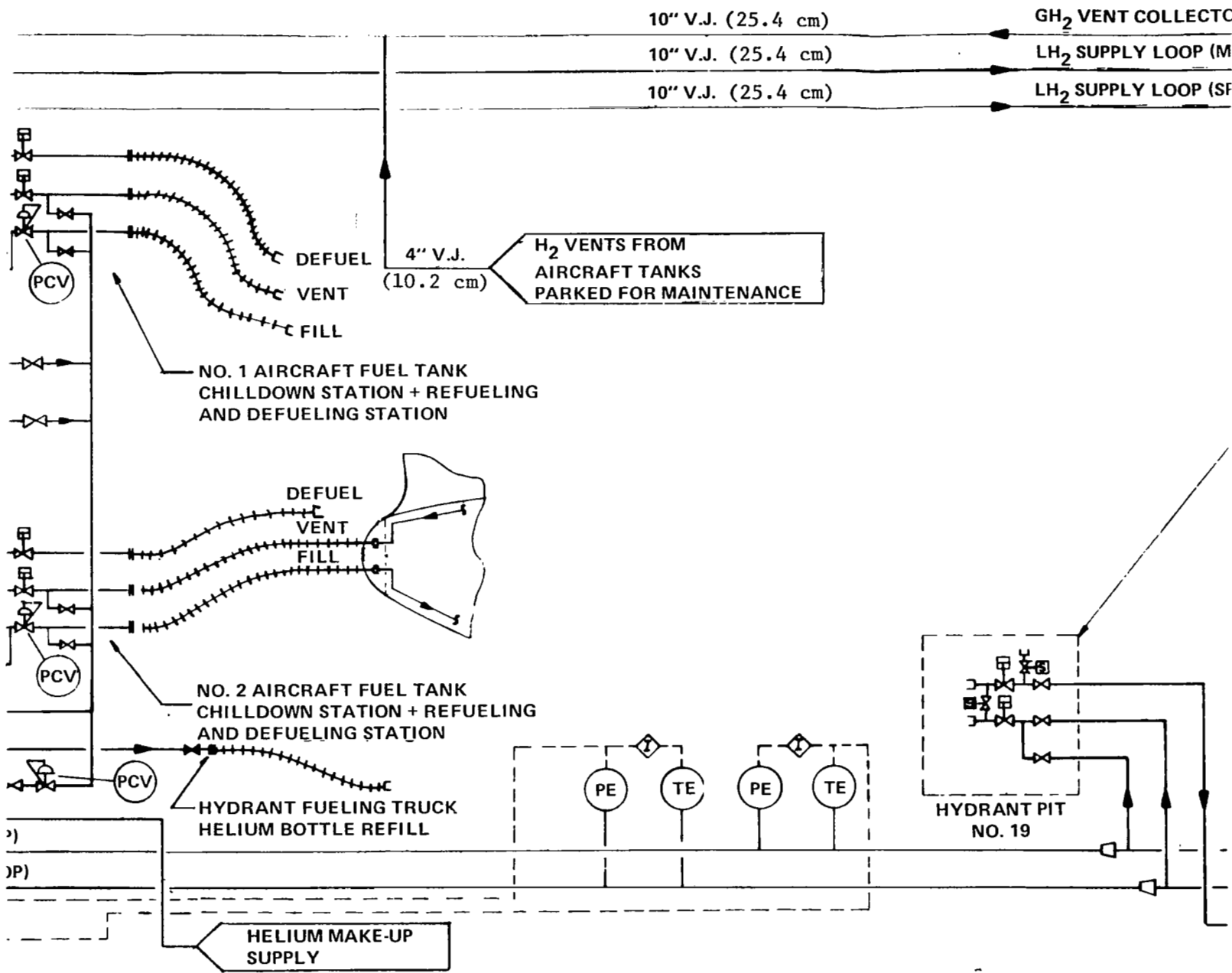

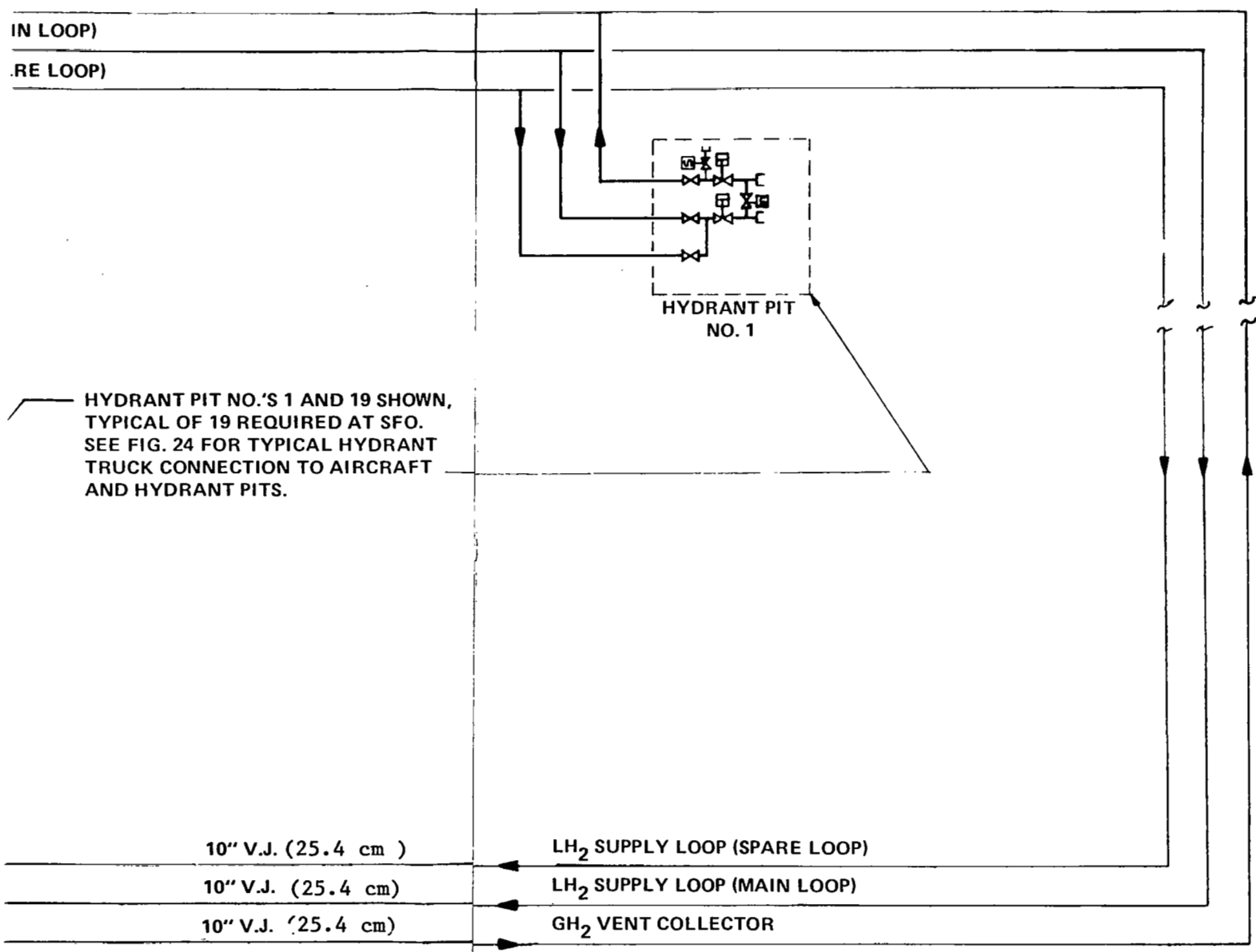

Figure 26. Distribution System Schematic

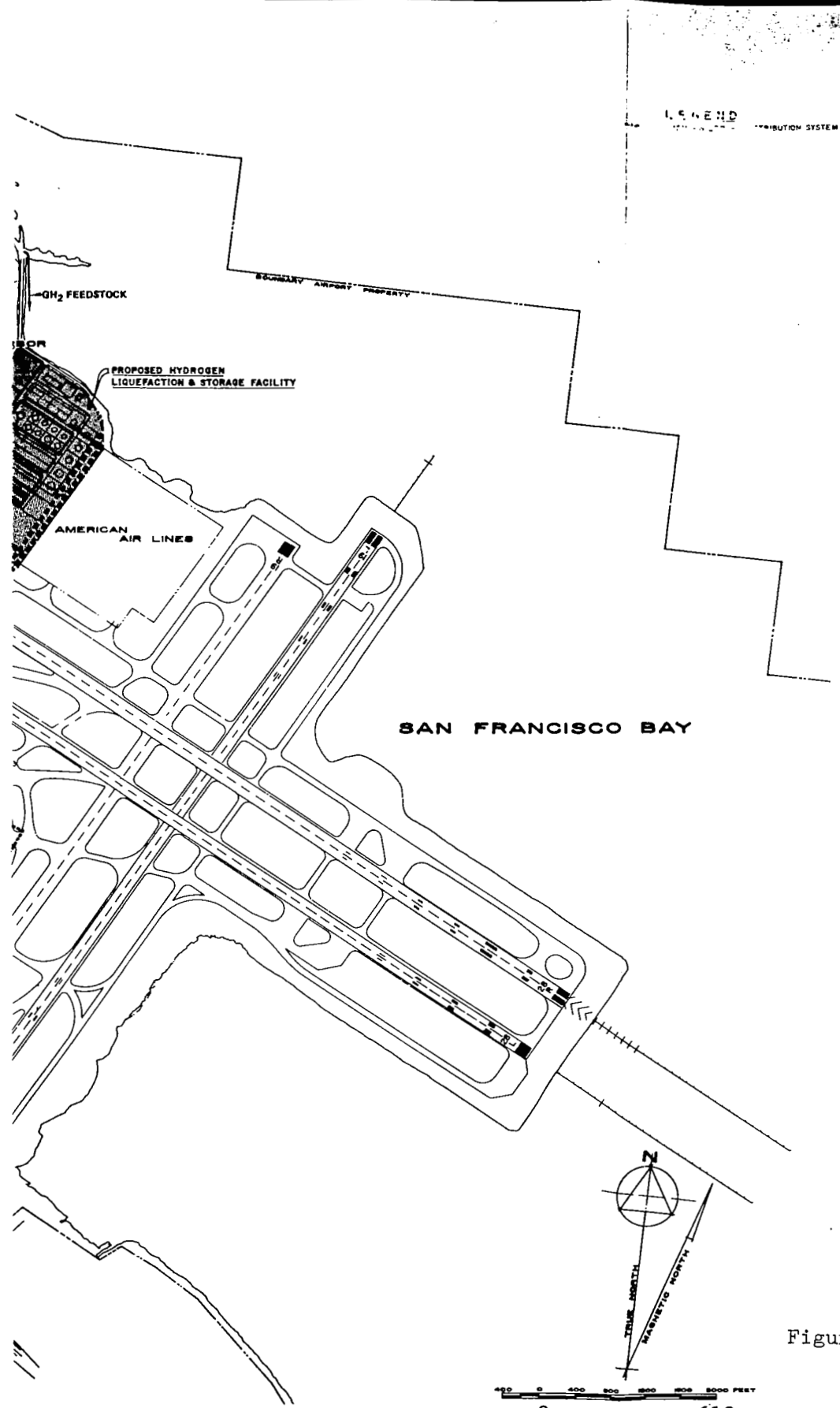

Figure 32. LH<sub>2</sub> Facility Installation For SFO



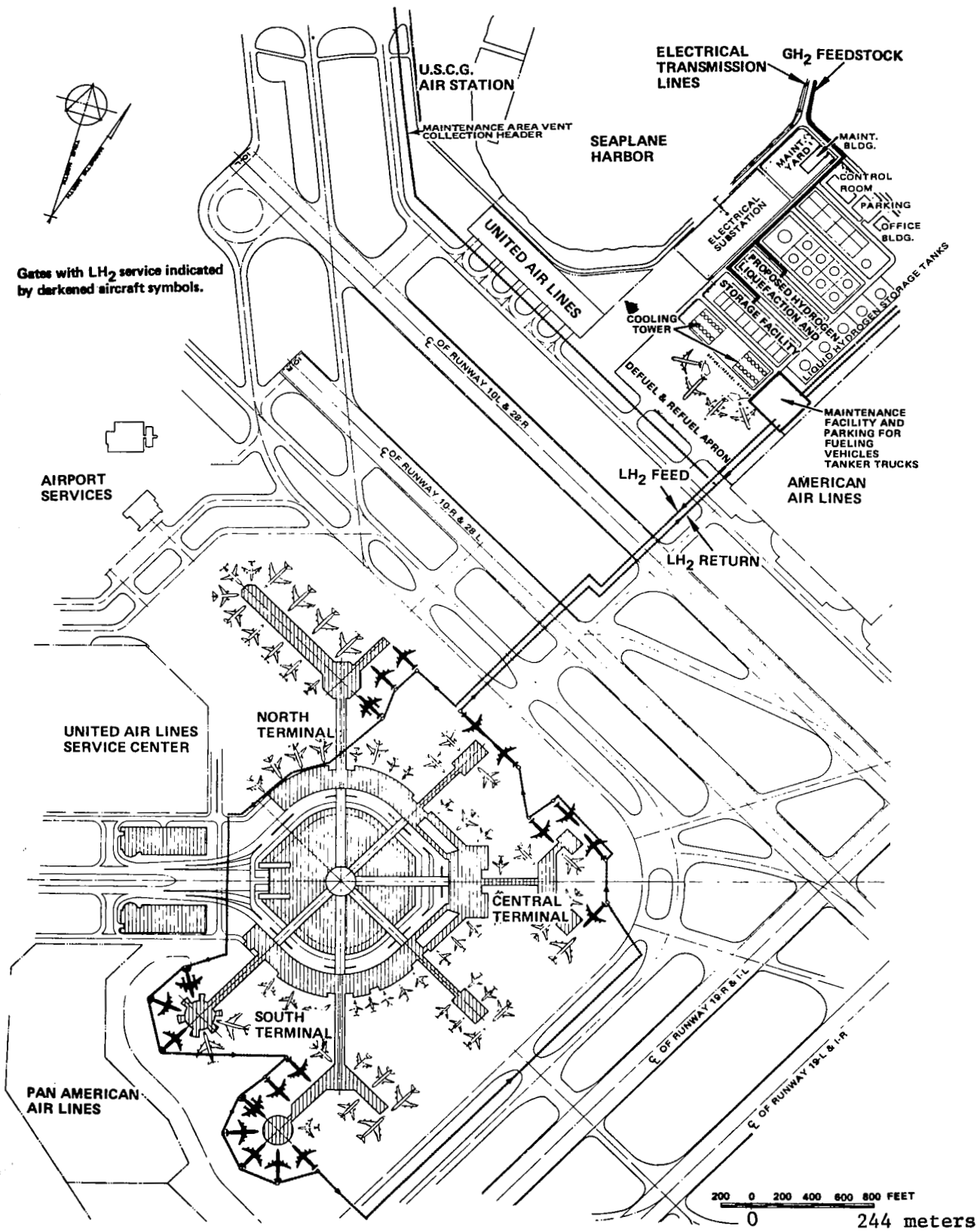

Figure 33. LH<sub>2</sub> Distribution System and Gate Positions at SFO

While the potential for reducing LH<sub>2</sub> service requirements through shared gate usage and rescheduling is recognized, it cannot be presumed that the carriers will be willing to share gate assignments or to use terminals which are physically separate from their Jet A activity areas. Furthermore, the projected flight schedules are predicated on the assumption of a national commitment to the use of liquid hydrogen as fuel for commercial transport aircraft. Since the nature of this commitment is for ultimate total conversion to the new fuel, it follows that ultimately sufficient LH<sub>2</sub> facilities will be available at SFO to service the total gate demand as determined.

The gate positions designated for LH<sub>2</sub> service (Figure 33) were generally selected on the basis of minimizing impact on planned gate configuration and apron maneuvering and parking areas required for aircraft and associated equipment. The higher length/span ratio of the LH<sub>2</sub> aircraft (1.26 compared to 1.18 for a 747) suggests some potential advantage to an angle parking configuration to minimize impact on planned aircraft maneuvering and positioning clearances. However, due to the particular nature of the terminal configuration at SFO and the location of the LH<sub>2</sub> gates within the total apron terminal complex, there are really no benefits to be derived by angle parking. In fact, angle parking may actually produce disbenefits in terms of additional terminal frontage and apron area requirements (Ref. 10).

Apron taxilane clearance requirements were analyzed in consideration of the area in the fueling zone (27.43 m (90 ft)) suggested as being restricted to exclude spark ignition vehicles. This graphic analysis, Figures 34 and 35, indicates that imposition of such a restriction will not seriously impact future aircraft positioning, however, apron movement will be limited to single taxilane capability between piers or satellites. It should be noted, however, that the planned configuration is similarly limited for conventionally fueled wide body aircraft.

The freedom of selection of LH<sub>2</sub> gates was limited to the extent that the developed gate requirements are airline specific and that the gates designated for LH<sub>2</sub> service must necessarily be those assigned for use by wide body aircraft. At the same time, however, it was also necessary to consider the compatibility of the LH<sub>2</sub> gate arrangement with respect to the loop concept of LH<sub>2</sub> distribution.

The basic LH<sub>2</sub> distribution system concept employs a circulating loop in which LH<sub>2</sub> (from a storage tank) is continuously circulated past each of the 19 hydrant stations and returned to the storage system. The LH<sub>2</sub> will be circulated in the loop at sufficient flow rate so that any heat leak into the distribution system will result in a liquid temperature rise of not more than 2° F at the last hydrant station on the loop. The excess circulating liquid is then returned to storage and introduced into a vented storage tank to be boiled back to saturation conditions. The advantages of the loop concept are the virtual elimination of fuel system chill-down time and the immediate availability of subcooled LH<sub>2</sub> at each hydrant station.

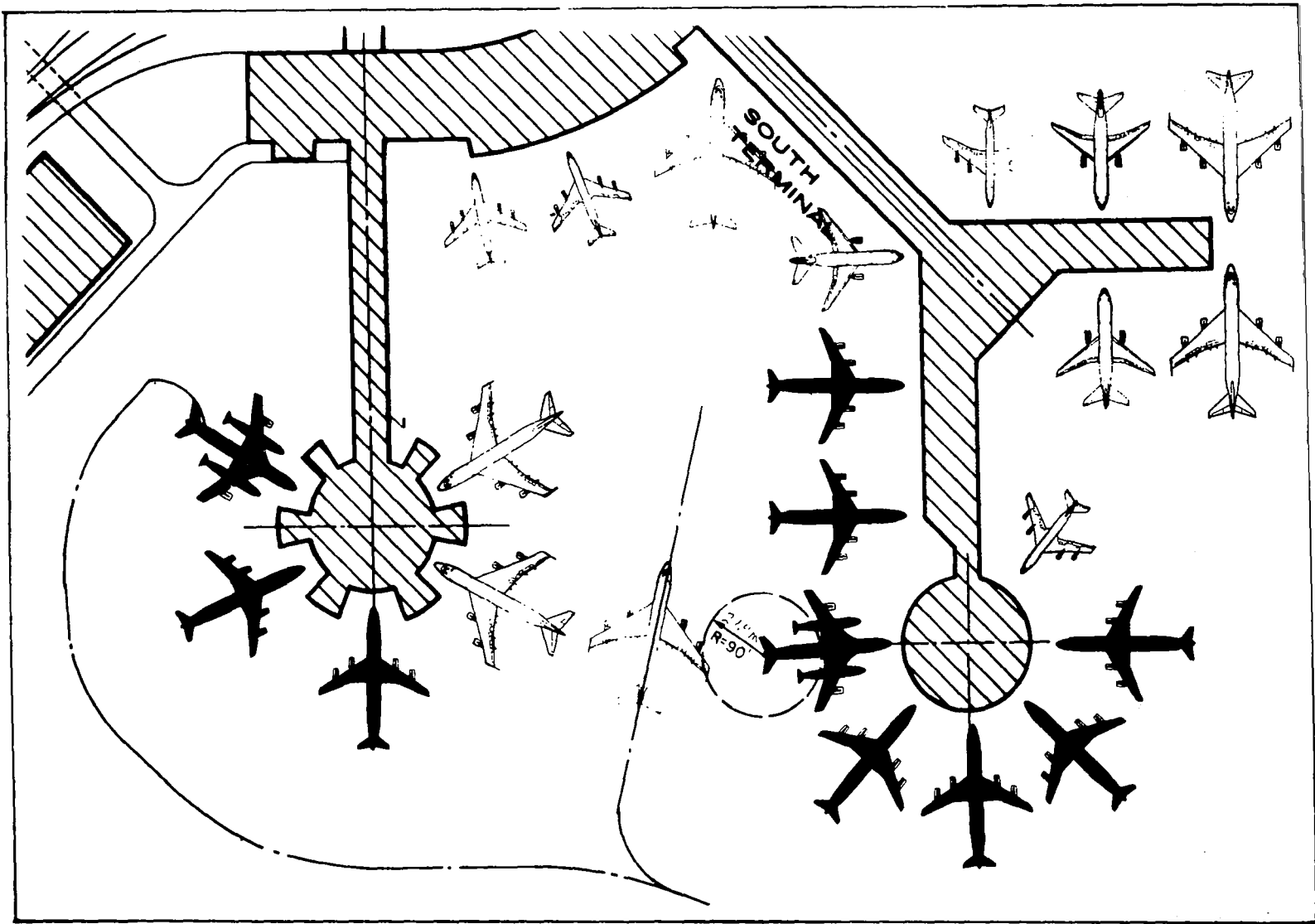

Figure 34. Apron Taxiway Clearances (South)

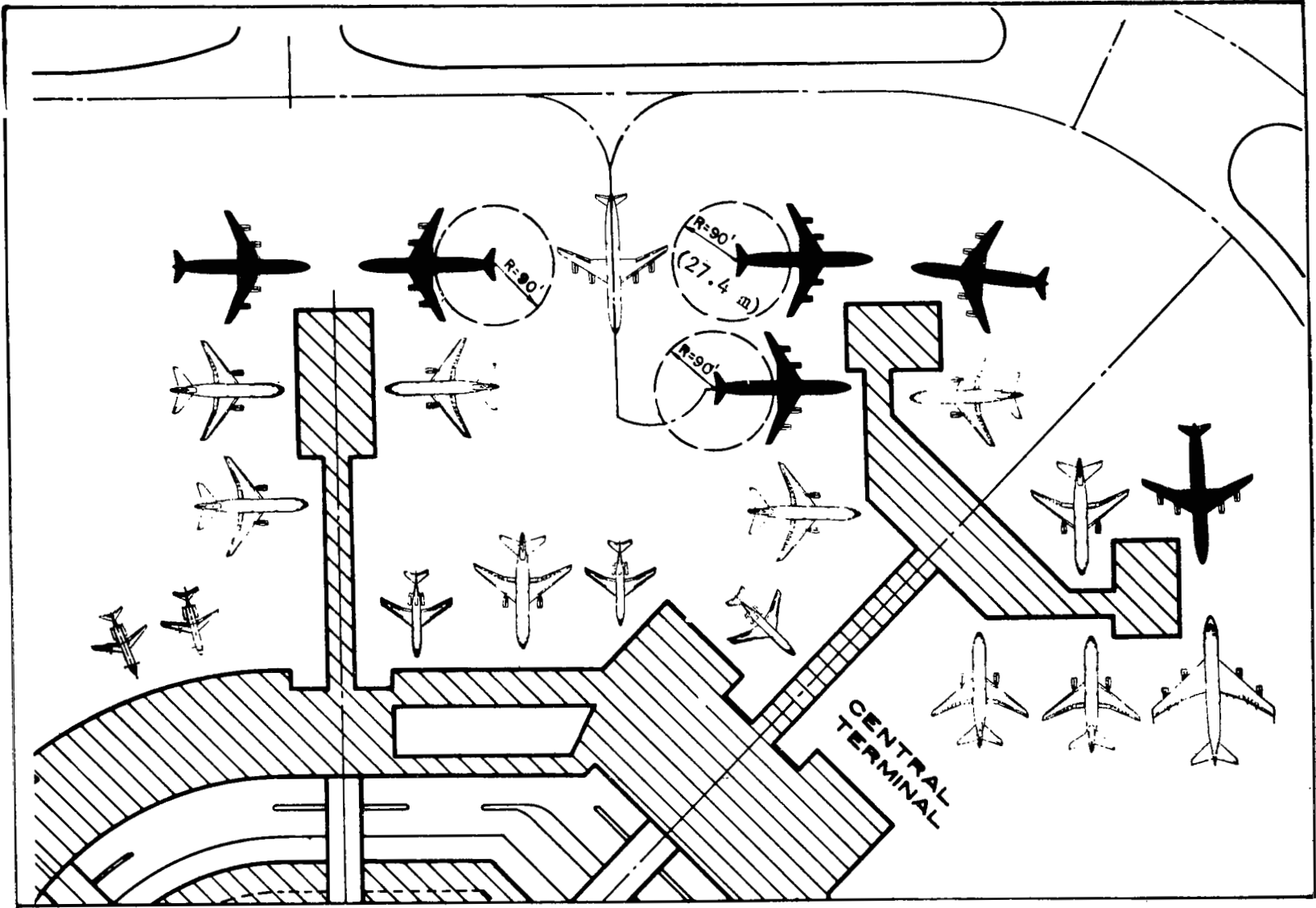

Figure 35. Apron Taxiway Clearances (North)



As detailed in Task 7, the distribution system actually consists of two parallel LH<sub>2</sub> supply loops. During periods of peak demand both loops will be in operation, circulating sufficient LH<sub>2</sub> past the 19 hydrant stations to service the peak fuel demand. However, during most of the year fuel demand will require the operation of only one supply loop, with the other providing a backup supply system. The dual loop system offers advantages in terms of providing system redundancy in case of failure in the primary supply line and will significantly reduce heat leak losses over a one-line system sized for peak fuel demand.

Gaseous hydrogen vented from both the aircraft and ground systems will be recovered by a GH<sub>2</sub> collection loop that is really just another element of the total LH<sub>2</sub> distribution system. Cold vent gas will be captured in a vent collection header that parallels the supply loop and returned to the liquefier for re-introduction into the liquefaction process.

It is proposed that the LH<sub>2</sub> distribution system (including two supply lines and a vent collection line) be routed below grade in a concrete lined open trench covered with steel grating. From the standpoint of ventilation considerations and maintenance requirements, and in order to provide a high degree of line accessibility, it is considered desirable that the distribution loop be routed primarily in open trench. Although it is recognized that an optimized design could conceivably identify sections where underground (tunnel) line routing would be acceptable, it is felt that application of the open trench concept to the entire distribution loop is entirely feasible and preferable during the earlier periods of use of the fuel. System improvements and modifications are made with relative ease and hazards of collection of an explosive GH<sub>2</sub> air mixture are virtually nil.

5.1.2 Summary of cost implications. - Evaluation of the problems and requirements of handling LH<sub>2</sub> fueled aircraft at a designated airport must necessarily include consideration of the economic implications of providing for the new fuel. Order of magnitude estimates of cost, where such costs could readily be identified, were developed for major elements of the LH<sub>2</sub> system consistent with the level of study effort. Other elements have simply been identified as constituting significant cost items that must be considered in developing the LH<sub>2</sub> system and no attempt has been made to put a value on these items. However, it is felt that the costs summarized in the following are sufficient to permit a first order assessment of the economic implications of a national commitment to the use of LH<sub>2</sub> as a fuel for long range commercial transport aircraft.

5.1.2.1 Capital costs. - Major capital investment will quite obviously be required in the liquefaction plant and storage facilities, and in the LH<sub>2</sub> distribution system. The cost implications of providing these facilities are summarized below:

Liquefaction/storage facilities and equipment. - The estimated total capital investment for the hydrogen liquefaction plant and storage facility is \$239 million. Additional capital requirements, including interest during

construction, startup costs, and working capital add another \$69.6 million to bring the total capital requirement to \$308.6 million. This will provide a facility which has a capacity of 10.50 kg/s (1000 tons/day) of liquid hydrogen into storage plus a tank farm having a total capacity of 18 927 m<sup>3</sup> (5 000 000 gal) of liquid hydrogen. These costs are for a completely installed and ready-to-operate plant and include the pieces of major equipment listed in Table XIX plus all the necessary supporting and auxiliary equipment required for operation of the facility.

Based on peak-month requirements, the liquefaction facility is oversized by about 18 percent when using efficient, high-speed fueling operations, but only by 11 to 12 percent based on more realistic, average fueling. Whether or not any significant cost reduction can be achieved by reducing plant capacity to match demand depends to a large extent on the design philosophy concerning the number of different module sizes to be made available. A single standard capacity module has advantages in reducing engineering design and procurement costs. If it were decided to design four identical production modules to provide 9.45 kg/s (900 tons/day) total capacity, the unit cost for the LH<sub>2</sub> product would be expected to decrease by approximately 2 to 2-1/2 percent.

Based on year-round average LH<sub>2</sub> requirements of approximately 6.93 kg/s (600 tons/day), the plant is oversized by nearly 52 percent. However, a peak sharing arrangement in which liquefaction capacity is reduced and storage capacity is correspondingly increased does not appear to produce an economic advantage.

Land requirements. - The liquefaction plant and storage facility concept discussed in Section 5.1.1.2 will require approximately 8100 m<sup>2</sup> of land fill in the seaplane basin north of the designated site (Figure 33). The concept also envisions a causeway across the seaplane basin providing access to the site and a route for power transmission lines and GH<sub>2</sub> supply.

Easements along the north airport boundary will also be required for the routing of power transmission lines from near the Bayshore Freeway to the liquefaction facility.

Although it is felt that the cost of reclaimed land, causeway, and required easements may not be significant in terms of total system cost, these elements are basic to the concept and obviously constitute important considerations in site development, and assessment of environmental impact.

Power supply. - As mentioned previously, it has been assumed that the electrical energy (≈332 megawatts) necessary for the production of LH<sub>2</sub> will be obtained commercially and can be furnished from the causeway indicated on Figure 32. While no attempt has been made to estimate the actual cost of facilities for satisfying this energy requirement, it is obvious that the impact of this demand level on the available energy supply will be significant.

Distribution system. - The capital costs of the distribution system are derived primarily from the following:

- Trench system construction
- LH<sub>2</sub> distribution equipment located in the storage area
- Installation of LH<sub>2</sub> distribution lines
- Hydrant pit installations
- Installation of vent gas collection system

The details of trench design are assumed to remain relatively constant over the length of the distribution system and, for purposes of this analysis, no attempt has been made to optimize the design in terms of variable lateral and vertical loads. A heavy steel grating designed for aircraft loads will be required in all apron areas, as well as runway and taxiway crossing. Although the heavy grating should logically extend to the limits of runway safety areas, there are portions of the trench between taxiways where a significantly lighter grating design would probably be acceptable. However, the additional cost of the heavier grating seems relatively insignificant when considering the increased margin of safety provided by insuring against violation of the trench by an aircraft or a heavy vehicle such as a crash-fire-rescue (CFR) truck. As a result, the estimated cost of trench construction reflects the use of a heavy steel grating (designed for aircraft loads) over the entire length of the distribution system.

The cost of trench construction is estimated to be approximately \$5 800 000 based on the costs of excavation and backfill, concrete trench and necessary expansion joints, dewatering system, and steel grating.

Within the LH<sub>2</sub> storage area there is a substantial amount of equipment that is really part of the distribution system. This includes piping, pumps, and valves associated with the primary distribution loop, as well as the equipment necessary to serve the defuel/refuel facility. The estimated cost of this equipment is approximately \$5 954 000.

As discussed in some detail in the Task 7 narrative, the LH<sub>2</sub> distribution system consists of two circulating distribution loops, each with stainless steel, vacuum-jacketed supply and return lines of 25.4 and 20.3 cm diameters, respectively. The capital cost of LH<sub>2</sub> supply/return lines and associated valves and fittings is estimated to be approximately \$12 743 000.

The investment in hydrant pit installations is derived principally from the costs of pipe risers, service isolation valves, control valves, couplings, and other necessary fittings. The total estimated cost of installing this equipment at the 19 designated hydrant stations is approximately \$960 000.

The major element of the vent gas collection system, as detailed in the Task 7 narrative, is a 25.4 cm vacuum-jacketed vent collection header that parallels the LH<sub>2</sub> supply loop. The system also includes a smaller 10.2 cm vent header serving the maintenance area. The GH<sub>2</sub> vent collectors and associated valves and fittings can be installed at an estimated cost of approximately \$5 917 000.

Summarizing the above material, the LH<sub>2</sub> distribution system will require a total estimated capital investment of approximately \$31 374 000. In addition, capital investment will be required for five or six hydrant fueler vehicles at an estimated cost of approximately \$70 000 each.

5.1.2.2 Operating costs of LH<sub>2</sub> system. - Operating costs for the liquefaction/storage complex are presented in detail in the Task 6 narrative. The major implications of operating costs relative to the unit cost of LH<sub>2</sub> production are summarized in the material that follows. Other operating and maintenance cost considerations are also noted.

Liquefaction and storage facility. - The estimated total annual operating cost (base case) for the hydrogen liquefaction plant and storage facility is \$133.6 million based on a total annual production of  $2.1071 \times 10^8$  kg (232 250 tons). Maintenance is included in this figure and amounts to \$3.9 million annually which equals 1.6 percent of total plant investment. For the base case, the major items of operating costs, comprising 89.7 percent of the total, are the gaseous hydrogen feedstock at \$76.4 million and electricity at \$43.5 million. Hydrogen feedstock was assumed to cost 36.27¢/kg (16.45¢/lb) of liquid product and the electricity was assumed to cost \$0.02/kWh for the base case. The feedstock cost is typical of estimates for hydrogen derived from gasification of coal in the 1985 - 2000 time period, while the cost of electricity was arbitrarily selected to represent purchased electricity in the same time period. The above estimates do not include the cost of the distribution system, nor do they assume recovery of the vented gas. These items are included in the cost breakdown shown in Section 5.1.2.3.

Distribution system. - The costs of operating the LH<sub>2</sub> distribution system are basically the LH<sub>2</sub> losses incurred during system operation. It is significant to note that the heat leak into the system is constant no matter what the liquid flow rate. In other words, losses are occurring continuously whether or not there is demand for fuel. This, of course, raises an interesting question; "How will system operating losses (costs) be accounted for, and on what basis will they be assignable to the carriers?"

While the depth of the present analysis is generally not sufficient to permit detailed evaluation of the cost of maintaining the LH<sub>2</sub> distribution system, the specialized nature of the technology associated with handling liquid hydrogen would suggest a cost level of two to three times that of maintaining a Jet A fuel system.

Major impact on other airport operational and maintenance activity would probably only occur should the airport assume operating responsibility for

the liquefaction, storage and distribution system. It is suggested, however, that these facilities might best be operated by some other entity specializing in cryogenic processes and perhaps extended to include contract cryogenic services as suggested in Section 5.1.3.3.

Refueling of a LH<sub>2</sub> aircraft at the terminal gate, as postulated, will require two men and one major piece of equipment while the comparable Jet A refueling operation requires four men using two pieces of equipment (assumed fueling at both wing points - two hydrant fuelers at two men each). Based on currently available information, the refueling times for the two fuels should not be appreciably different. Until more conclusive information can be developed, it is probably safe to assume that the gate refueling with LH<sub>2</sub> should be no more costly than current procedures using Jet A fuel, considering only the refueling operation costs.

5.1.2.3 Liquid hydrogen cost. - The estimates of the investment and operating costs for the liquefaction, storage, and distribution facility postulated for SFO which were presented in the previous section are summarized in Table XXIV. The question marks indicate that the economic implications of these elements may be significant, and that further effort is needed to identify properly their magnitude.

The investment and operating costs shown in the table provide a basis for calculation of the production cost of liquid hydrogen delivered to the aircraft using the SFO facility. The basis for the cost calculations is presented in Table XIV.

The method of calculation involves the use of relations given in Section 4.1.7 as follows: The equation for present value of the production cost is given in Equation (12).

$$PV = 4.1887 (AOC) + 0.95956 (I) + 0.52 (S) + 0.9666 (W) \quad (12)$$

The present value of annual income required to meet production costs is given by the following expression:

$$PV = 4.1887 (AI) \quad (13)$$

Equating (12) and (13) and solving for annual income gives:

$$AI = AOC + 0.22908 (I) + 0.12414 (S) + 0.23067 (W) \quad (14)$$

Unit production cost is obtained by dividing Equation (14) by the annual production rate. Total annual production required with the 15.7 percent operations loss rate is  $2.10706 \times 10^8$  kg (232 265 tons). Substituting cost data into Equation (14) gives \$213 019 000 for annual income and a unit cost of \$0.943/kg (\$0.4274/lb) for the liquid hydrogen produced in the situation where there is no recovery of LH<sub>2</sub> boiloff.

TABLE XXIV. SUMMARY OF INVESTMENT AND OPERATING COSTS  
(LH<sub>2</sub> System - San Francisco International Airport)

System Element	Capital Cost (\$ 10 <sup>6</sup> )	Annual Operating and Maintenance Cost (\$ 10 <sup>6</sup> )
Energy Supply Facilities		
o Power easements and transmission structures	(Included in cost of electric power.)	
o GH <sub>2</sub> supply pipeline	(Included in cost of feedstock.)	
Liquefaction/storage plant	308.6	133.6*
Distribution system		
o Trench construction	5.8	Not Significant
o Piping/valves, etc.	25.6	?
Hydrant fueler vehicles	<u>0.4</u>	<u>?</u>
Total	340.4	133.6

\*Includes GH<sub>2</sub> feedstock and electric power (see section 4.4).

However, the vent gas recovery system, which is included in the cost of the distribution system, will recover essentially all the LH<sub>2</sub> boiloff, except that lost in flight. The recoverable GH<sub>2</sub> amounts to 91.5 percent of the total estimated loss of 15.7 percent. Recovery of this cold gas reduces the amount of feedstock gas required and also represents a valuable source of refrigeration. Using the above equations the corrected base case cost of liquid hydrogen was calculated to be \$0.887/kg (\$0.4026/lb) when 91.5 percent of the vent gas is recovered.

The base case unit cost in the preceding paragraph is based upon a hydrogen feedstock cost of \$0.363/kg (\$0.1645/lb) of liquid hydrogen produced and an electricity cost of 2.0¢/kWh. To permit the determination of liquid hydrogen costs for other values of feedstock and electricity, Figure 36 is presented in which the cost of electricity is varied from zero to 4.0¢/kWh and the cost of feedstock is varied from \$0.11 to \$0.76/kg (\$0.05 to \$0.35/lb). The unit cost of liquid hydrogen varies from \$0.566 to \$1.442/kg (\$0.257 to \$0.654/lb) over this range of feedstock and electricity costs. It is assumed that all investment and operating costs are included in the cost of the feedstock and electric power, i.e., the cost of the gas production facility, gas pipeline, power generation, power substation, etc., are all accounted for in the prices paid for the GH<sub>2</sub> and the electricity. In this manner the implication of these costs, once determined, can be used to find the final unit cost of the delivered hydrogen.

A breakdown of the base case cost of LH<sub>2</sub> is tabulated in Table XXV which shows the contribution of each cost element to the total unit cost of liquid hydrogen. The three parameters which have the greatest impact on the unit cost are:

- The cost of the hydrogen gas feedstock delivered to the liquefaction facility.
- The cost of purchased electricity.
- Capital investment for the liquefaction and storage facility.

Operating costs contribute \$0.5790/kg (\$0.2626/lb) which is equivalent to 65.2 percent of the total unit cost of \$0.8877/kg (\$0.4026/lb). Therefore, the operating cost items which have a major impact on the cost of liquid hydrogen in the overall cost picture are feedstock at 35.8 percent and electricity at 22.1 percent of the total unit cost. Efforts at total cost reduction will be most fruitfully applied in the reduction of the cost of these two plant inputs as well as efforts in reducing plant investment since these three items collectively account for 92.7 percent of the total cost of liquid hydrogen.

Manpower requirements for operation, maintenance and supervision of the facility total 103 persons. Included are 84 shift personnel, 10 office personnel, 5 technical personnel and 4 supervisory personnel. Total labor costs, salaries, administration and overhead add only 1.2 percent to the final cost.

- 1985 TECHNOLOGY
- LIQUEFACTION, STORAGE & DISTRIBUTION INVESTMENT AND OPERATING COSTS INCLUDED
- VENTED GAS RECOVERY INCLUDED
- BTU COST BASED ON LOWER HEATING VALUE OF 119,895 kJ/kg (51,590 Btu/lb)

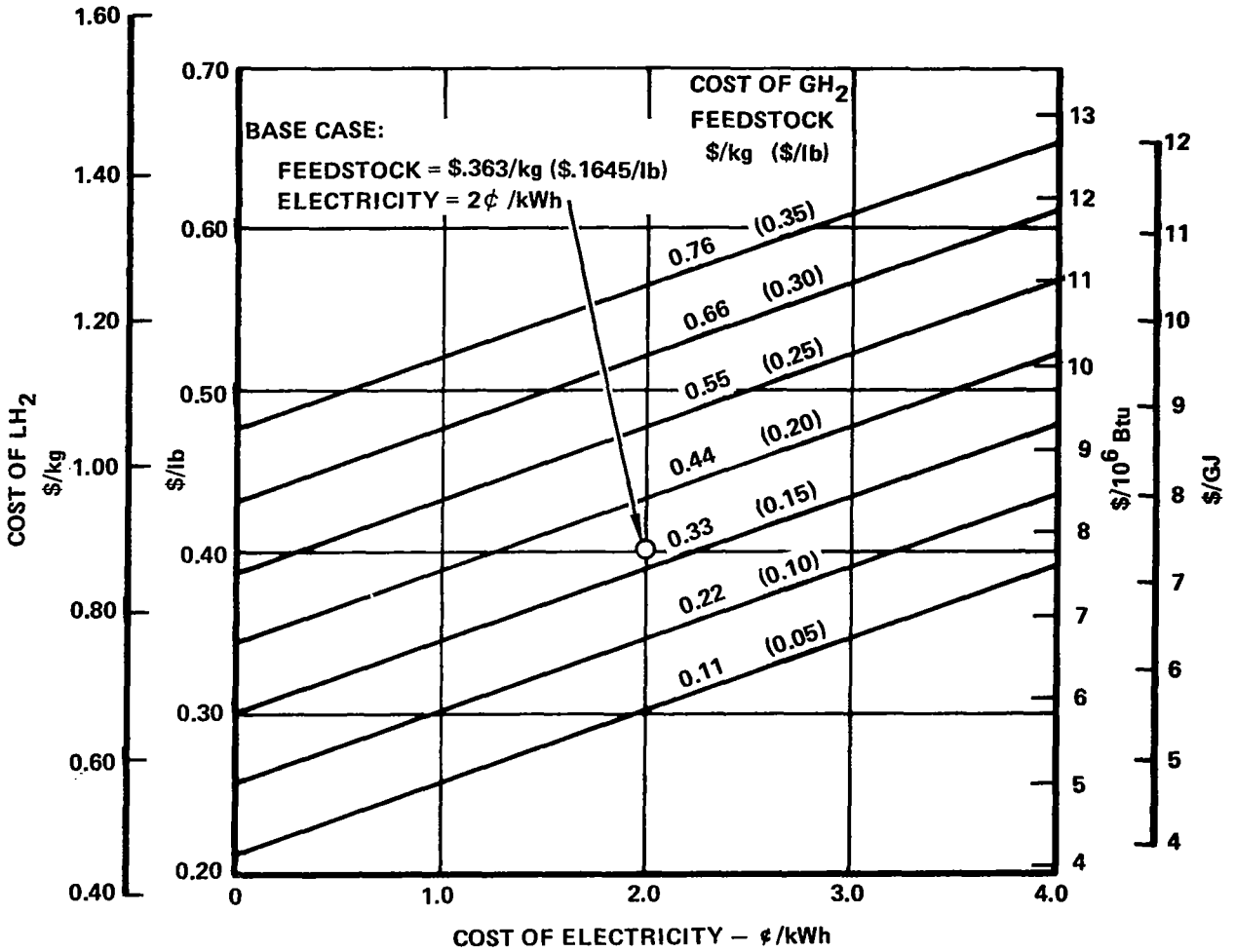

Figure 36. Effect of Electric Power and Hydrogen Gas Feedstock Costs on Unit Cost of LH<sub>2</sub>



TABLE XXV. BASE COST OF LIQUID HYDROGEN AT SFO

- Feedstock cost = \$0.363/kg (\$0.1645/lb)
- Electric power cost = 2¢/kWh

	\$/kg	(\$/lb)	Percent
<b>Operating Cost:</b>			
Feedstock*	0.3177	(0.1441)	35.8
Electric Power	0.1965	(0.0891)	22.1
Labor, Administration and Overhead	0.0108	(0.0049)	1.2
Chemicals, Supplies, Water, Taxes, and Insurance	<u>0.0540</u>	<u>(0.0245)</u>	<u>6.1</u>
Subtotal	0.5790	(0.2626)	65.2
<b>Capital Investment:</b>			
Liquefaction and Storage Facility Investment	0.2600	(0.1179)	29.3
Distribution System Investment	0.0346	(0.0157)	3.9
Start-Up Costs	0.0040	(0.0018)	0.45
Working Capital	<u>0.0101</u>	<u>(0.0046)</u>	<u>1.15</u>
Subtotal	<u>0.3087</u>	<u>(0.1400)</u>	<u>34.8</u>
Total	0.8877	(0.4026)	100

\*Cost of feedstock (GH<sub>2</sub>) shown is adjusted to account for vent gas which is recovered and reliquefied.

The use of four 2.63 kg/s (250 TPD) plant modules results in a larger-than-needed liquefaction facility. Based on year-round average capacity of 6.98 kg/s (665 TPD) it is oversized by about 50 percent. However, if peak-month fuel requirements are to be met, either the plant must be sized for peak-month operations or additional storage capacity must be provided. If the plant is to be sized to provide the 7.68 kg/s (731.4 TPD) fuel requirements plus the 15.7 percent operations losses for a 350 day operating year, it must have a total capacity of 9.27 kg/s (883 TPD). The reduction in unit cost resulting from capital investment for a 9.45 kg/s (900 TPD) vs a 10.50 kg/s (1000 TPD) facility would amount to 2.76¢/kg (1.25¢/lb).

If, on the other hand, one were to adopt a peak-shaving method of operation by installing additional storage tanks to accommodate the shortfall during peak-month operation, the liquefaction facility could be reduced in size. Assuming the extreme condition where the plant is sufficiently large to produce only the average year-round requirement of 6.98 kg/s (665 TPD), it would be necessary to provide an additional 19 storage tanks of 3785 m<sup>3</sup> (1 000 000 gal) capacity, each. These would cost \$76 000 000 compared with a \$75 000 000 reduction in plant investment. Thus, there is essentially no economic incentive for one concept over the other. Furthermore, since the capital investment for both storage tanks and liquefaction plant are essentially linear with capacity, the conclusion is valid over the range of capacities involved. One has almost complete freedom of choice to install either liquefaction capacity or storage capacity without serious economic penalty.

The 10.50 kg/s (1000 TPD) plant size which has been assumed provides a 13.3 percent margin of over-capacity based on peak month operations. It is therefore capable of handling an increase over the projected liquid hydrogen fueled air traffic. A considerable increase in traffic could be accommodated by the addition of storage tanks to the existing facility to provide a peak shaving operation.

5.1.3 Special facilities and equipment. - While it is generally concluded that the demand for totally new and unique facility/equipment concepts is not extensive, the use of LH<sub>2</sub> fuel in air transport service will certainly warrant special facility and equipment considerations relative to the following:

- Operation of the LH<sub>2</sub> fuel system
- Aircraft ground support services
- Aircraft maintenance

The special and unique requirements of these activities are identified and discussed in some detail in the narrative material of Tasks 7, 8 and 9. The primary facility/equipment considerations, as well as some of the still unresolved questions relevant to those requirements, are summarized in the material that follows.

5.1.3.1 Fuel system operations. - Distribution of LH<sub>2</sub> to the 19 terminal gates presents some unique problems not previously encountered in LH<sub>2</sub> systems such as those associated with the space program. Aircraft utilization and scheduling constraints demand system operating flexibility that will be derived primarily from new applications of existing technology, but will also require consideration of new concepts of facilities, equipment, and procedures necessary for the safe and efficient handling of large quantities of LH<sub>2</sub>. These requirements are noted briefly below.

Fueler vehicle. - The hydrant fueler vehicle concept introduced in Task 4 represents a very special equipment requirement unique to the LH<sub>2</sub> aircraft. The fueler vehicle will provide the necessary connection between the LH<sub>2</sub> supply and vent lines in the hydrant pit and the aircraft LH<sub>2</sub> fill and vent connect points in the aircraft tail cone. As envisioned, the fueler will carry all necessary equipment and controls to permit semi-automated purification and inertion of connecting flex hoses prior to and following the fueling operation.

A pop-up fueling station that would retract into a pit enclosure beneath the apron and perform essentially the same functions as the fueler vehicle was suggested as a possible alternative. However, the installation and maintenance of 19 such stations does not appear to be an economically viable solution in view of the fact that the requirement for simultaneous fueling is limited to only 4 aircraft.

Six hydrant fuelers would probably be required to service the LH<sub>2</sub> gate demand. An appropriate area for storage and maintenance of these cryogenic vehicles is shown in the liquefaction/storage complex (Figure 33). It should also be noted that the maintenance of LH<sub>2</sub> vehicles certainly falls within the purview of the contract cryogenic services concept suggested in Section 5.1.3.3.

Fuel transfer vehicles. - Although the question of providing LH<sub>2</sub> to the maintenance facilities has not been totally resolved, it is generally considered that LH<sub>2</sub> should be provided via tank truck to the maintenance facilities and engine test stands as required to perform necessary testing. While this need does not present any new or unique equipment requirements, it does serve to identify mobile equipment necessary to the LH<sub>2</sub> airport concept.

A tank truck could also be utilized in topping off the aircraft tank in the unlikely event of an unusually long delay at the end of the runway. It should be pointed out, however, that in order to perform the aircraft fueling operation, the tanker will either have to be equipped with a boom that will reach the aircraft tail or operate in conjunction with a hydrant fueler vehicle.

Trench dewatering. - In view of the open trench concept employed for the LH<sub>2</sub> distribution system, consideration will have to be given to dewatering of the trench. Due to existing ground water conditions, dewatering will probably have to be accomplished by pumping. Although flows are considered to be

relatively minimal, it is estimated that six pumping stations may be required in order to avoid excessive trench depths over the relatively long distance of the distribution loop. Again, providing for dewatering of the trench is a relatively routine undertaking but one that must be recognized as being necessary to the effective operation of the LH<sub>2</sub> system.

Distribution system maintenance equipment. - It seems reasonable to assume that maintenance of the LH<sub>2</sub> distribution system would not become an additional maintenance function to be performed by airport personnel. In view of the specialized nature of handling cryogenic systems, it is postulated that maintenance of the LH<sub>2</sub> distribution system should ideally be performed by the same entity operating the liquefaction, storage and distribution systems (this, of course, could possibly be the airport). In any case, this maintenance function will require specialized facilities and equipment unique to the use of the cryogenic fuel.

Maintenance of the distribution system will require a shop building with primary functional areas as follows:

- Weld shop, with overhead crane, for heli-arc welding of vacuum jacketed pipe.
- Space for chemical cleaning using industrial detergents and possibly pickling acids.
- Space to accommodate a typical work bench operation.

The shop should also be equipped with several large vacuum pumps, as well as several portable field units (possibly as many as 6) for use in the repair of distribution system piping. It is suggested that the portable vacuum pump units be skid mounted and movable with a fork lift.

The required servicing and testing of system valves and pumps indicates a need for a small cryogenic test facility. This facility is envisioned as a small, separate, barricaded area with all the equipment necessary to perform required proof tests on system valves and pumps.

As suggested for the hydrant fueler, the facilities, equipment and procedures required to maintain the LH<sub>2</sub> distribution system might best be accommodated by contract cryogenic services providing the specialized equipment and personnel necessary for the operation and maintenance of cryogenic systems (see Section 5.1.3.3.).

5.1.3.2 Routine ground services. - Present plans at SFO call for installation of fixed services at the terminal gates for many of the routine ground support operations as opposed to the mobile equipment presently used. These facilities can be designed to serve conventional aircraft, as well as the LH<sub>2</sub> fueled aircraft. Baggage and cargo loading and offloading equipment can serve both aircraft types without major redesign, with the possible exception of power trains. These and other differences are noted below.

Equipment for double deck aircraft. - The study aircraft differs from current designs in that two passenger decks of approximately equal seating capacity are provided. The question of the viability of two-story aircraft cabins is not unique to the LH<sub>2</sub>-fueled transport and must be resolved in the context of new generation aircraft, whatever the fuel used. As discussed in Section 4.7.1, double deck cabins need not create a requirement for new, complex ground support equipment or for new terminal facilities. Existing terminal facilities can be revised to provide direct access to the upper deck via jetways, as well as to the lower deck. Alternatively, passengers could board through conventional jetways to the lower deck and use inplane stairs to the upper deck. Disadvantaged passengers would be allocated seats in the most accessible areas.

Food and liquor service would be provided to galleys located either on the lower deck, or below decks, as on some current wide-body aircraft. Service to the upper deck would be provided via the inplane elevators.

Flight crew access would have to be provided by means of a separate device, e.g., ramp stairs.

Ground service equipment power. - To achieve the ground segment target times mentioned earlier, it will be necessary to perform some operations with mobile powered equipment during the fuel transfer operation. Available data indicate that spark ignition engines or any device that could create ignition of a GH<sub>2</sub>-air mixture resulting from a spill or leak should be excluded from an area within 27.43 m of any components involved in the fuel transfer.

The aft cargo compartment door is just within this area on both of the study aircraft and it will be desirable to retain access for loading or off-loading baggage and cargo containers during fuel transfer. As suggested in the Task 4 narrative, if subsequent work validates the requirement for 27.43 m clearance, or similar criteria, it may be necessary to pressurize the compartment to prevent inleakage of a combustible mixture of H<sub>2</sub>/air, and to develop a family of diesel powered, air started ground support equipment to avoid ignition sources in the vicinity of fueling operations. Such equipment might be needed for handling and transporting containers. Alternatively, redesign of the aircraft to relocate the cargo compartment access points farther forward could eliminate the need for special GSE power.

In general, the present family of GSE can be adapted to the LH<sub>2</sub> aircraft. The only additional item required is a means of access for the flight crew. No special ground handling equipment unique to the LH<sub>2</sub> fuel, other than the fueler itself, appears to be needed. The period in question may be one in which all aircraft are moved between gates and runway via powered bogies on the aircraft, or by a family of high speed tractors, for reasons of fuel economy, noise reduction and, in the case of conventionally fueled aircraft, air pollution. In the era of LH<sub>2</sub> fuels, this may continue to be cost effective, particularly if such equipment is generally available. Certain obvious advantages would accrue in that aircraft engine operation would be virtually absent from the apron-terminal area where fuel transfer is occurring, although it does not appear to be essential to the concept.

5.1.3.3 Aircraft maintenance. - Specific aspects of the study aircraft related to maintenance are discussed in detail in Section 4.6. Certain questions were raised during study team coordination, and not all of them could be resolved. The following discussion highlights the decisions, assumptions, and questions relevant to aircraft maintenance.

Defuel/refuel apron. - The decision not to supply LH<sub>2</sub> to the maintenance facilities by pipeline because of cost considerations (primarily low use rates which lead to high boiloff loss fractions) was not popular with the operating members of the study team, who felt quite strongly that fuel supply to maintenance areas would be essential. This issue is one that warrants examination in future work. For purposes of this study, the consensus reached was that the liquid fuel would be tanked to the maintenance facilities and engine test stands when needed, in sufficient quantities to perform required testing. Checks or repairs not involving the fuel systems will be performed in the hangars, with the vent gas collection system connected. When work or inspection of tanks and fuel systems are required, the aircraft will be defueled and purged away from the base, with chilldown/refueling also completed away from the base after the work is completed and proofed.

For these purposes, a defuel/refuel apron is included in the concept adjacent to the liquefaction/storage facility. Four parking stands served by two stations are indicated, the number being selected as an estimated peak requirement, based on a chilldown cycle of several hours for an aircraft with warm tanks. The apron is sized to permit convenient maneuvering with conventional nosegear towbar and tugs. Two towers are envisioned, each designed so that direct flex connections can be made to two aircraft at their tail cone attach points. Aircraft can be defueled at any time.

The fueling stations are supplied from both the main and supplementary distribution loops and the vent collection loop, as described in Task 7. The system differs from the hydrant operation only in that the aircraft tail cone is accessible from a catwalk or similar structure, with a single flex connection to the headers. The difficulty of precisely spotting the vertical stabilizer when pushing the aircraft back to the station suggests that some flexibility must be designed into the connection devices.

The apron can accommodate some long term parking of aircraft, if needed. Location of the apron is such that no part of the parked aircraft will penetrate the runway protective surfaces, or obtrude into the taxiway obstacle-free areas.

Line maintenance. - The narrative of Section 4.6 emphasizes the need to design the aircraft for easy line replacement of fuel system components to the extent possible. Introduction of limited cryogenic line services suggests a need for mobile equipment to purify and inert fuel system sections isolated for changing line replaceable units. A purging vehicle of this type offers no unique design problems. No other special equipment is foreseen to accomplish line maintenance functions.

Major maintenance. - Aspects of major maintenance peculiar to the LH<sub>2</sub> aircraft are discussed in detail in Task 8. There appear to be many difficulties in adapting current procedures and routines for Jet A fueled aircraft. Most of the problems relate to extensions of downtime seemingly needed to perform the necessary maintenance. It seems clear, however, that careful programming of the procedures can solve many of the problems, although the solutions will likely be different from current practices. Impacts of the fuel system components' relationship to other aircraft systems is discussed in Task 8 in terms of potential maintenance problems.

The concept envisions tanker delivery of the liquid to a small fuel storage and distribution system at the engine test stand locations. Depending on the frequency of use of the stands, it may be worthwhile to consider supplying the engine feed systems directly from a mobile unit adapted for the purpose.

As noted earlier, most aircraft maintenance activity is assumed to be conducted at the maintenance dock with the tank venting to the airport collection system. A failure in the vent gas collection system, or leakage of any sort, could result in collection of an H<sub>2</sub>/air mixture in the high point of the hangar or adjacent building areas. Consideration needs to be given to designing maintenance facilities as self-venting buildings or with massive air change equipment to minimize this potential hazard.

A specification should be established for maintenance hangers which would require an open clerestory or similar roof form incapable of collecting significant amounts of GH<sub>2</sub>. Several alternatives applicable to new hangar design are available which can solve the problem.

The specialized nature of the technology associated with handling cryogenic hydrogen led to consideration of a possible need for contract services in this area. The facility could be constructed for and manned by specialists in cryogenic processes. The operator of the facility (an airline, a Fixed Base Operator, the airport, etc.) could furnish franchised services to all carriers operating the equipment for inspection and repair of anything related to fuel systems. Conceivably, these services could be operated by the same entity operating the liquefaction, storage, and distribution system, and the fueler vehicles. At SFO the plot adjacent to the LH<sub>2</sub> plant, currently leased by American Airlines, might make an excellent location for an operator of contract cryogenic services.

The desirability of the contract services approach is suggested as a possibility for consideration. While the high technology required for dealing with LH<sub>2</sub> is recognized, a similar climate can be said to surround many of the systems in a modern transport aircraft. As experience is gained in the use of liquid hydrogen as a fuel, there is precedent to suggest that the required skills for dealing with it will come to be no more awesome than those associated with repairing a glide slope receiver.

The concept for a LH<sub>2</sub> facility at SFO described in summary in this section and discussed more fully in the preceding sections of this report appears to be technically feasible, subject to further study in certain of the areas which have been identified. Based on the knowledge available to the members of the study team, there are no readily apparent technical barriers to prevent conversion of a modern airport for service to a fleet of LH<sub>2</sub> fueled aircraft. The costs outlined above should be sufficiently comprehensive to permit a first order assessment of the economic feasibility of a national commitment to the fuel, in terms of the impact on ground facilities.

## 5.2 Task 11: Suggested Changes in LH<sub>2</sub> Aircraft

As a result of the considerations of this study the following changes or possible tradeoffs are suggested for the subject aircraft:

- a. The addition of a vent selector valve in the aircraft tail cone was found necessary to permit collection of vent gas (GH<sub>2</sub>) during fueling operations and while the aircraft is out-of-service. The valve is shown in the revised fuel system schematic (Figure 37). It allows connection of the fuel tank vent to either the ground vent collection adaptor or the in-flight vent located in the vertical tail.
- b. The need for purification of the interconnecting plumbing before fueling, and for inertion following fueling, required the addition of a bleed valve, shown in Figure 37, and some modification of function of the main fueling control valve. The bleed valve allows escape of GH<sub>2</sub> resulting from the chill-down of the main fuel line prior to opening of the main fueling control valve. The main fueling control valve also serves to prevent tank overpressure by shutting off in the event tank pressure exceeds the desired value either during refuel or tank chill-down operations. In this manner it serves as a back-up to the level control valve in the event of a failure of that valve to shut off.
- c. An area of tradeoff suggested during the study involves examination of potential effects of an increase in the tank operating pressure from the present value of 145 kPa (21 psia). Increase in pressure would increase the aircraft tank weight but would result in a reduction in the liquid hydrogen losses in the ground system during fueling by allowing the delivery of LH<sub>2</sub> at a higher temperature before incurring flashing losses both in the distribution system and in the ground storage tank. The study would involve analysis of the effect this change would have on the economics on both the aircraft and ground systems over their useful lives.
- d. A reduction in time required to refuel would be desirable from the operator's view, to reduce turnaround time. To do so would require an increase in both aircraft and ground fuel system capacity, weight, and cost. Higher boiloff losses would be incurred. An evaluation of the most desirable rate would involve the airframe supplier, airline operator, and ground complex designer in joint consideration of



the ultimate mix of aircraft (short, medium and long range) and the effect of refueling time on operation of each type of aircraft to arrive at a satisfactory compromise.

- e. A major area of concern is the possible need for frequent inspection and maintenance of the LH<sub>2</sub> tank and insulation system. Consideration of the involved process of defueling, inertion, warmup, and purging required to gain access to a tank, followed by purification and chill-down before refueling, dictates that such access be kept to the absolute minimum. In order to minimize such aircraft out-of-service time several approaches need to be explored and evaluated:
- design for long life and minimum maintenance, i.e., minimize need for inspection and repair.
  - evaluate integral vs nonintegral tank designs to determine cost and performance tradeoffs associated with each.
  - design all operational tank components which must be located within the tank so they are accessible from outside the tank for maintenance and replacement without the need for physical entry.
- f. A requirement similar to the above exists for all pumps, valves and line mounted equipment to minimize down time. The objective would be to make the maximum number of components line replaceable units (LRUs) which could be removed and repaired or replaced without requiring inertion, purging, or causing contamination of adjacent lines or equipment. This will require much ingenuity and development on the part of both the aircraft system designer and the component supplier.
- g. The aircraft tank and/or fuel line insulation system must be compatible with, or protected from, hydraulic fluid. In any case it must not be possible for the insulation to soak up or retain the fluid.
- h. Task 8 suggested only two main tanks in lieu of the four previously shown. This is reflected in the Figure 37 schematic. Each engine supply system is independent in keeping with the intent of FAR 25.253. Surge bulkheads are provided as required and the boost pumps are enclosed in surge boxes to ensure fuel availability during aircraft maneuvers at low fuel level. The concept needs to be given detail attention to assess its practicability and potential advantages and disadvantages.
- i. The arrangement of the long range LH<sub>2</sub> aircraft with fuel tanks both fore and aft of the passenger compartment places a demand for extreme reliability on the fuel quantity gaging system to monitor the fuel quantity and resulting c.g. location. The primary quantity gaging

system will probably be a type which provides continuous (analog) readout. A back-up system which would give digital readout at discrete levels could be provided to increase overall reliability.

Further changes to the aircraft system will certainly be suggested as a result of more detailed studies of both the aircraft and ground systems.

## 6. RECOMMENDED RESEARCH AND TECHNOLOGY DEVELOPMENT

The following significant items are suggested for consideration in succeeding work leading to implementation of hydrogen fuel at airports for commercial transport service.

Certain items from section 5.2, Suggested Changes in LH<sub>2</sub> Aircraft, will require additional study and analysis. These items include:

- Item c: Determination of Preferred Tank Design Pressure
- Item d: Investigation of Optimum Refueling Rate
- Item e: Study of Design & Maintenance Characteristics of Tank/Insulation System to Provide Optimum Operational Cost and Performance.
- Item f: Study of Accessibility and Maintainability Requirements for Fuel System Components

Other items suggested for investigation or development include the following:

- a. LH<sub>2</sub> Use initiation study. - An airport system study of city-pairs and airline route structures, and potential GH<sub>2</sub> or LH<sub>2</sub> supply development, with the objective of constructing complete program scenarios. This is an extension of Task 2 in the present study. It would result in suggestions for alternate scenarios relating total production output to priority cities, route development, demonstration projects, regulatory changes, facility constraints, etc.

The study should include consideration of the economics of fuel ferrying versus trip fueling. This suggests that major fueling facilities might be located at a limited number of stations, with top-off or emergency trip fuel available at most stations. The systemwide benefits and costs, including ground operations costs, would be determined.

- b. Model air terminal design. - A study to develop one or more new airport prototypes to optimize the terminal operations of an air transport fleet founded on the new fuel is suggested. The present study has demonstrated that current procedures and techniques can

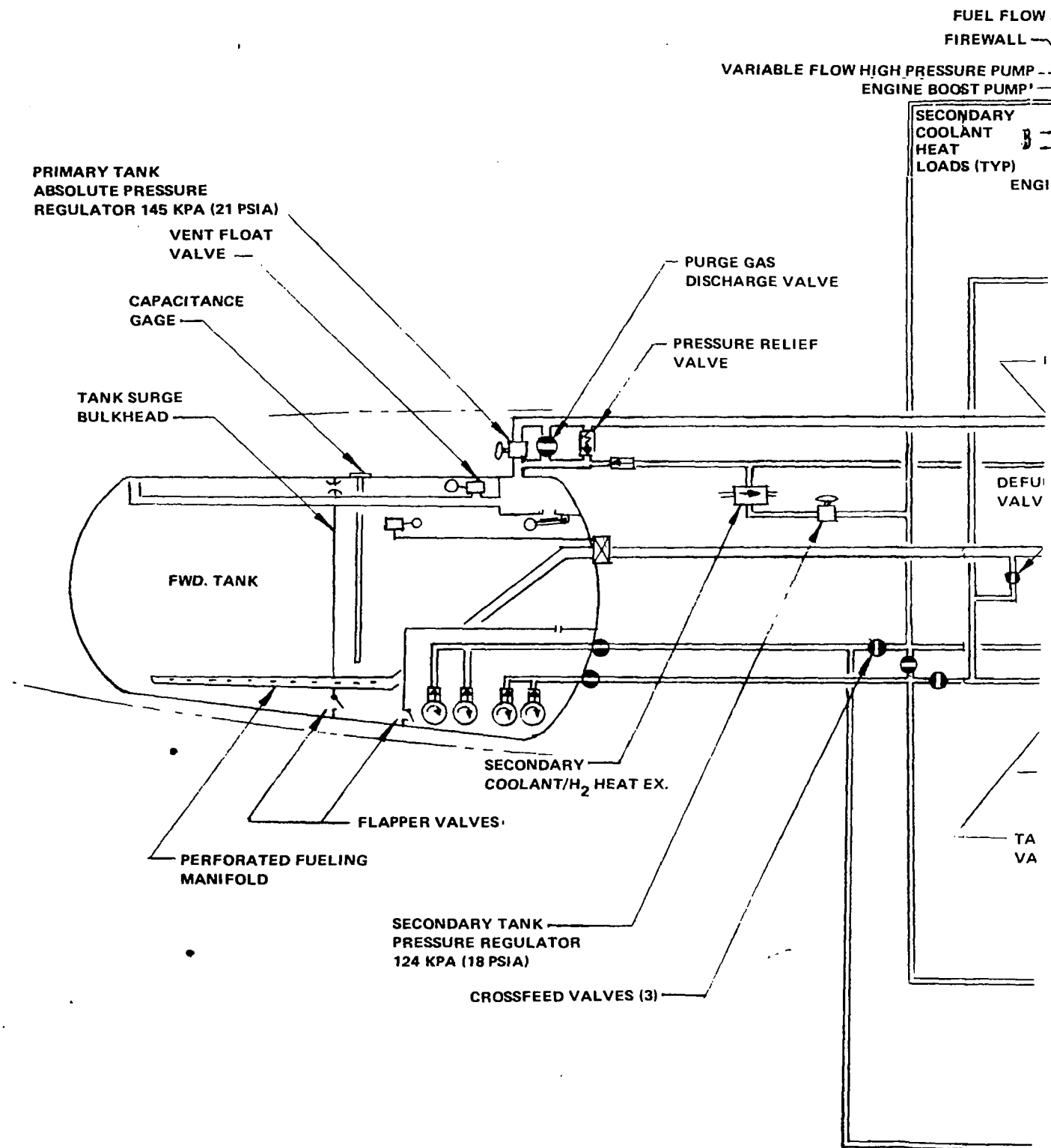

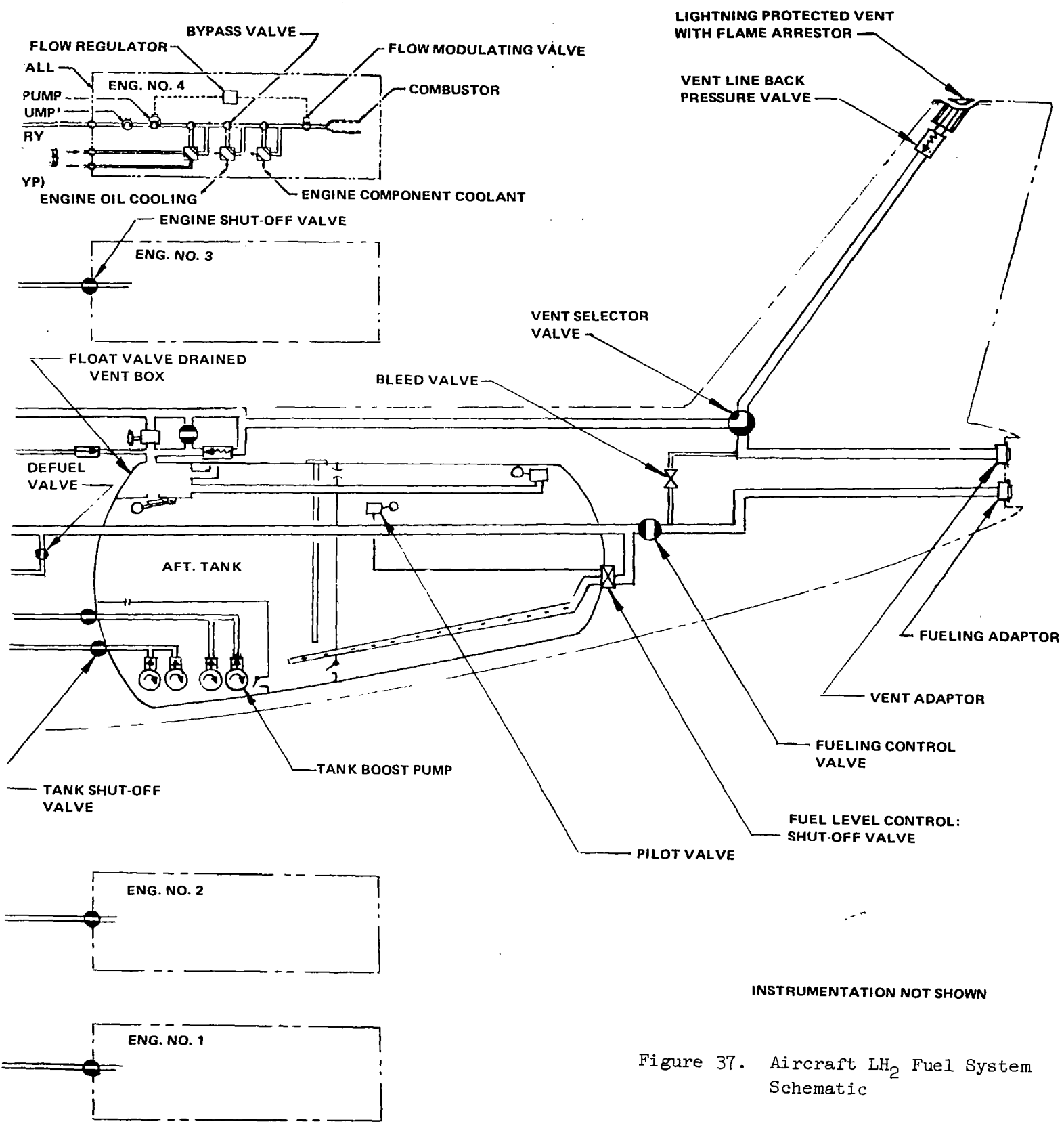

INSTRUMENTATION NOT SHOWN

Figure 37. Aircraft LH<sub>2</sub> Fuel System Schematic

be adapted to the LH<sub>2</sub> transport, but has also developed sufficient evidence to suggest that alternative approaches to the ground segment of operations may be preferable. What is suggested here is a wide open study of alternate systems for ground operations, not simply further adaptations. Our current air terminals evolved from the railroad station. A study to investigate new logical concepts of air terminals designed specifically for use of LH<sub>2</sub> fuel, without constraint of modifying existing facilities, should produce interesting results which will be useful as goals for attainment.

- c. Transporter air terminal operation. - Investigate the possible cost savings which might be realized by reduction of hydrogen losses using the "shared gate" fueling approach rather than the "leased gate" approach. This would apply particularly to the "transporter" air terminal systems.
- d. LH<sub>2</sub> airport power generation study. - An airport power systems study of the feasibility of generating power on-site for directly driving the liquefaction equipment rather than through use of electric power. The study should consider total airport and fuel system energy requirements and the optimization of the supply systems, considering the airport as an independent entity.
- e. GSE & ramp operations analysis. - A detailed study of ramp management problems and solutions for the prototype aircraft is recommended. The study would involve definition of the GSE envelopes prior to docking and their movements during the ground segment, fixed apron service connect points, new mobile equipment for cabin and galley services, and related positioning and operational implications. It would define operations which could be performed simultaneously with the fueling process.
- f. Hazards analysis. - An analysis of hazards involved in air terminal ground operations, including study of risk levels associated with kerosene and avgas operations would be performed and acceptable target risk levels for LH<sub>2</sub> operations would be explored. This would be a first step in determining what concurrent activity could be conducted during fuel transfer operations and the results might influence future vehicle and airport design exercises.
- g. Building design for safety. - An analysis of aircraft maintenance base building requirements, hangar and shop safety requirements, etc. This study should include the entire range of airport building regulatory implications related to the use of the new fuel, e.g., code and underwriter impacts affecting public occupancy buildings. It would help resolve the question of what operations might be performed in a maintenance dock with LH<sub>2</sub> fueled aircraft.

- h. Para/ortho hydrogen production. - The cost of LH<sub>2</sub> production can be minimized by optimum selection of para/ortho content for that LH<sub>2</sub> which is to be used immediately vs that which is to be stored. The present study assumed 60 percent para conversion for LH<sub>2</sub> to be used within 2 or 3 days and 97 percent para for that LH<sub>2</sub> which might be stored for several weeks. The proposed study would consider airport use schedules, LH<sub>2</sub> production and storage capacity, and determine an optimum schedule for para/ortho production to minimize costs.
- i. LH<sub>2</sub> reservoir pressurization system. - Investigate liquid hydrogen reservoir pressurization system to reduce vaporization losses. Present system uses liquid hydrogen that has been vaporized and returned to the top of the reservoir. With very large reservoirs the losses associated with this system become significant. Alternate systems can be developed and evaluated.
- j. LH<sub>2</sub> vaporization in aircraft. - Some information is known concerning liquid hydrogen vaporization losses in trailers and tank cars that are in motion. However, essentially nothing is known about the liquid hydrogen vaporization losses while the aircraft is in flight. This is an area that warrants study - possibly experimental work would be required.
- k. LH<sub>2</sub> quantity measure. - A system needs to be developed to accurately meter or gage the amount of fuel delivered to the aircraft. Possibly one that will permit rapid fill for the bulk of the delivery and topping off the tank at a slower rate.
- l. LH<sub>2</sub> ground supply pumps. - The development of large, efficient liquid hydrogen pumps for the ground supply system must be considered. Long life and reliability are vital characteristics.
- m. Recovery of GH<sub>2</sub>. - Hydrogen flash-off has been determined to have high economic value. Various methods have been proposed for its recovery. No systems such as these have been developed. There are several items that will require development attention. The need for repurification of the return hydrogen vent gas should be evaluated. The development of cold gas holders and cold compressors are of major concern.

## 7. CONCLUSIONS

As a result of this preliminary assessment it was concluded that it is rely feasible and practicable to provide facilities and equipment at Francisco International Airport (SFO) to accommodate LH<sub>2</sub>-fueled, long-, commercial transport air traffic starting in 1995.

Initiation of use of LH<sub>2</sub> fuel in commercial airline service in 1995 was indicated on pronouncement of a national commitment to that end in 1980. Development and installation of airport facilities is not the pacing item

in this schedule. It appears that development of a capability to provide appropriate quantities of gaseous hydrogen by coal gasification, and/or electrolysis of water, will be the crucial element. For purposes of this study, 2000 A.D. was used as a date for studying the fuel and traffic handling requirements of SFO, allowing five years after initiation of service with LH<sub>2</sub> for its use to build to significant levels.

The preferred arrangement of liquid hydrogen facility for SFO involves piping GH<sub>2</sub> feedstock directly to the airport; building a liquefaction and storage complex on available, currently unused land within airport boundaries - (however, the required 254,000 m<sup>2</sup> of land must be supplemented by reclaiming approximately 81,000 m<sup>2</sup> from the seaplane harbor); and piping LH<sub>2</sub> through a vacuum jacketed pipeline in a closed loop around the terminal area to provide means for fueling aircraft at conventional gate positions.

It was concluded that LH<sub>2</sub> aircraft could refuel at conventional gate positions, using essentially conventional ground support equipment, in nominally the same elapsed time as current Jet A fueled aircraft of equivalent capacity. Exceptions to this statement are that 1) LH<sub>2</sub> fueling is accomplished at the tail cone which is 10m (33 ft) in the air and would require a special fueler vehicle, and 2) the flight crew must be provided a separate access to the flight station since there is no passageway between the passenger compartment and the cockpit in the subject aircraft. Nineteen of the 81 gate positions planned for SFO subsequent to 1985 can accommodate the long range traffic assumed for the LH<sub>2</sub> aircraft.

Five spherical storage vessels, each 71 feet in outside diameter, will contain a total of 18,925 m<sup>3</sup> of LH<sub>2</sub>. The storage tanks will be insulated by 0.76 m of perlite in an evacuated annulus surrounding the LH<sub>2</sub> container. The net evaporation rate from these tanks is conservatively estimated to be 0.06 percent of tank contents per day with 13 Pa (100 microns) pressure in the annulus. However, experience with tanks of similar design at Cape Kennedy have demonstrated boiloff rates of only 0.02 % per day so somewhat lower loss rates than theory indicates may be expected.

It is estimated that the plant and equipment required to provide LH<sub>2</sub> capability at SFO will amount to \$340.4 million in 1975 dollars. This does not include any consideration of the investment required for the supply of either gaseous hydrogen feedstock, or for electric power. According to the ground rules of the study, both of these items were assumed to be available and the costs were included in the rate paid for the gas and electric power.

Some of the more specific conclusions which were reached during this study are the following:

- The projected maximum requirement for LH<sub>2</sub> at SFO in 2000 A.D. is 7.68 kg/s (731.4 tons/day) delivered to the aircraft engines. This is for the average day in the peak month.

- The selected LH<sub>2</sub> supply and aircraft fueling system involves boiloff losses amounting to 15.7 percent. Of this total, 91.5 percent is recoverable and can be reliquefied. Only 1.34 percent of the total LH<sub>2</sub> manufactured is lost. That is the quantity vented in flight, or during operation of the aircraft on the ground.
- It is economically preferred to pipe GH<sub>2</sub> to the airport and locate the liquefaction plant on site. If the liquefaction plant cannot be located on the airport, LH<sub>2</sub> can be moved most economically by vacuum jacketed pipeline for distances up to about 40 miles. For greater distances, railroad tank car is the preferred means of transport. If railroad tank cars must be used for any reason, it is most advantageous to locate the liquefaction plant at the GH<sub>2</sub> source and move the LH<sub>2</sub> the entire distance to the airport.
- The transporter system for handling aircraft loading and unloading appears to offer interesting potential for many airports. It was not suited to SFO and was not examined in detail.
- The shared gate approach has the potential of minimizing both capital and operating costs.
- The external tank aircraft design concept is considered inferior to the internal tank version in terms of refueling procedure, passenger acceptance, and ground operations in general.
- Use of a pump-fed system, rather than a pressure system, was significantly advantageous for moving LH<sub>2</sub> from the airport storage tanks to the aircraft tanks. Similarly, the preferred airport fuel transfer system is a loop arrangement which empties from one storage tank into another after being circulated past all of the gate positions. This assures immediate availability of LH<sub>2</sub> to any gate with no chill down required.
- A defuel/refuel area was provided near the LH<sub>2</sub> storage tanks so aircraft which are to be out-of-service for extended periods, or which require inspection or repair of their fuel tanks, can be efficiently processed.
- Consideration of the cycle time required to defuel, warm-up, and inert LH<sub>2</sub> aircraft tanks before inspection and/or repair of tank components can be performed, in addition to the corresponding time required to purge, purify, and refuel, means that LH<sub>2</sub> tank and associated fuel system components must be developed to a high degree of reliability before being put in service.
- The projected SFO LH<sub>2</sub> liquefaction facility would require approximately 332 MW of electric power. There is much that can be done to minimize the requirement for purchased power and further studies are recommended.



- Cost of LH<sub>2</sub> delivered to the aircraft using the SFO facility is calculated to be 89¢/kg (40¢/lb = \$7.81/10<sup>6</sup> Btu) based on GH<sub>2</sub> feedstock at 36¢/kg (16.5¢/lb) and electric power at 2¢/kWh.

## 8. RECOMMENDATIONS

In view of the need to develop an alternate for petroleum-based Jet A type fuel in the foreseeable future, and because LH<sub>2</sub> has been shown to be a most attractive candidate, it is recommended that a comprehensive development program be actively pursued.

Numerous suggestions have been presented in Section 6 which outline worthwhile technology development and study items pertinent to airport facilities and equipment. Of these, the following are recommended for immediate implementation:

- LH<sub>2</sub> use initiation study
- Model air terminal design
- Transporter air terminal operation
- LH<sub>2</sub> airport power generation study
- GSE and ramp operations analysis, in combination with a hazards analysis.
- Building design for safety.

In addition, a societal impact study is recommended to provide an assessment of the effect conversion of the air transport industry to LH<sub>2</sub> fuel would have on society in general. In this study a hypothetical but realistic scenario depicting the transition to hydrogen would be developed, and the economic ramifications, the institutional barriers and incentives, and the social dislocations and opportunities of all major stakeholder classes in society would be disclosed. Stakeholder classes whose participation in the evolutionary scenario would be described include the following:

- airlines
- aircraft manufacturers
- fuel suppliers
- airport operators
- consumers
- government regulators

This study would provide important input and an order of priorities for the technical work. In addition it would acquaint, and hopefully convince, many stakeholders of the need for early conversion of commercial aviation to hydrogen fuel.

12

3

## APPENDIX A

### HYDROGEN SUPPLY METHODS

This appended material is a detailed presentation of the calculation of refueling losses. It is based on a preliminary estimate of the design of the fueling system for the purpose of determining the total quantity of  $LH_2$  to be supplied and transported so that Task 3 studies could be conducted. Differences exist between the configuration of the fueling circuit assumed herein and the configuration finally adopted in Task 7; specifications for the system assumed here are presented.

#### A1. CALCULATION OF LIQUID HYDROGEN REFUEL REQUIRED VS NET FUEL TO ENGINES

Table 1 shows refueling calculation results for three different missions.

- Sample Mission - Selected to give two missions per day average at an aircraft utilization of 4000 hr/yr.
- Design Mission - Based on 23 995 kg (52 900 lb) block fuel weight
- Contingency Mission - Based on completely full tank at takeoff. Block fuel weight is 27 941 kg (61 600 lb)

The Sample Mission is very close to the typical or average mission from Task 2. Using the Sample Mission as an example, the source of the various fuel losses will be explained in detail. The flight duration of the Sample Mission will be 5.5 hr and, at a 4000 hr/yr utilization rate the non-utilized or ground time will be 6.5 hr to give a total time per mission of 12 hr. The boiloff loss due to heat leak into the aircraft fuel tank while in flight amounts to 455.0 kg (1003 lb). Ground-time heat leak loss will be 665.0 kg. (1466 lb). The unit boil-off rates of 1.379 and 1.705 kg/min (3.04 and 3.75 lb/min) were mutually agreed upon by Lockheed and Linde. Net engine fuel requirements for the flight amount to 11 340 kg (25 000 lb) and this must, of course, be loaded into the tank. While in flight, some of the  $LH_2$  must be vaporized for displacement of the fuel which has been consumed. For this mission, 302 kg (665 lb) are required but this is less than the 455 kg (1003 lb) loss due to heat leak so no additional loss is incurred from this cause. The difference, 140 kg (338 lb), must be vented from the aircraft while in flight. Total liquid required during the mission is therefore the sum of the net fuel to the engines and the flight time boil-off or 11 795 kg (26 003 lb).

TABLE 1. CALCULATION OF LIQUID HYDROGEN REFUEL REQUIRED VS. NET FUEL TO ENGINES

	<u>Units</u>		<u>Sample Mission</u>		<u>Design Mission</u>		<u>Contingency Mission</u>	
	SI	Customary	SI	Customary	SI	Customary	SI	Customary
Mission time	hr	hr	5.5	(5.5)	11.7	(11.7)	*13.88	*(13.88)
Nonutilized time (average)	hr	hr	6.5	(6.5)	13.8	(13.8)	16.4	(16.4)
Total time allocated to mission			12.0	(12.0)	25.5	(25.5)	30.28	(30.28)
(Avg. utilization = 4000 hr/hr)								
Tank heat leak boil-off								
During mission time (3.04 lb/min)	kg	lb	455	(1 003)	968	(2 134)	1 149	(2 532)
During nonutilized time (3.76 lb/min)	kg	lb	665	(1 466)	1 412	(3 113)	1 678	(3 700)
Total	kg	lb	1 120	(2 469)	2 380	(5 247)	2 827	(6 232)
Net fuel to engines	kg	lb	11 340	(25 000)	23 995	(52 900)	27 941	(61 600)
Boil-off required for displacement of net fuel (2.66%)	kg	lb	302	(665)	638	(1 407)	743	(1 639)
Remainder of mission boil-off	kg	lb	153	(338)	329	(727)	405	(893)
Extra vaporization for displacement	kg	lb	0	(0)	0	(0)	0	(0)
Motion losses	kg	lb	0	(0)	0	(0)	0	(0)
Total liquid required during mission	kg	lb	11 795	(26 003)	24 963	(55 034)	29 090	(64 132)
Boil-off during nonutilized time	kg	lb	665	(1 466)	1 412	(3 113)	1 678	(3 700)
Refueling pump work	kg	lb	81	(178)	169	(373)	198	(437)
Refueling system losses	kg	lb	305	(672)	305	(672)	**610	** (1 344)
Total liquid per mission	kg	lb	12 845	(28 319)	26 849	(59 192)	**31 576	** (69 613)
Loss saved by warming liquid	kg	lb	-252	(-555)	-415	(-914)	-619	(-1 365)
Net liquid per mission	kg	lb	12 593	(27 764)	26 434	(58 278)	**30 957	** (68 248)
Total loss per mission	kg	lb	1 505	(3 319)	2 854	(6 292)	3 635	(8 013)
	%	%	13.3	(13.3)	11.9	(11.9)	13.0	(13.0)
Net loss per mission after warming liquid	kg	lb	1 254	(2 764)	2 439	(5 378)	3 015	(6 648)
	%	%	11.1	(11.1)	10.2	(11.2)	10.8	(10.8)
Expected average % loss	%	%	12.2	(12.2)	11.0	(11.0)	11.9	(11.9)
Venting during refuel(s)								
Displacement	kg	lb	331	(731)	702	(1 547)	818	(1 804)
Heat leak boil-off during refuel	kg	lb	65	(143)	65	(143)	130	(286)
Piping system loss	kg	lb	187	(412)	187	(412)	374	(824)
Pump work	kg	lb	81	(178)	169	(373)	198	(437)
Saved by warming liquid	kg	lb	-252	(-555)	-415	(-914)	-619	(-1 365)
Total from cold supply tank	kg	lb	412	(909)	708	(1 561)	901	(1 986)
Total from warm supply tank	kg	lb	664	(1 464)	1 123	(2 475)	1 520	(3 351)

\*Estimated from other data in Task 2 report

\*\*Two refuelings required because required liquid exceeds maximum possible quantity (MT tank) of 64 209 lb. This means a top-off operation.

TABLE 1. (continued)

	First Refueling From Cold Supply Tank		Last Refueling From Warm Supply Tank	
	SI kg	Customary lb	SI kg	Customary lb
Venting during maximum refuel				
Displacement for 29 090 kg (64 132 pounds) of liquid	774	(1 706)	774	(1 706)
Tank Heat Leak 38 minutes	65	(143)	65	(143)
Transient Piping 38 minutes	150	(332)	150	(332)
Staycold piping portion for 38 minutes	41	(90)	41	(90)
Pump Work	188	(414)	188	(414)
Subtotal	<u>444</u>	<u>(979)</u>	<u>444</u>	<u>(979)</u>
Potential Saving in Loss by Warming Liquid (-1284) Actual Savings	-444	(-979)	0	(0)
Net Subtotal	<u>0</u>	<u>(0)</u>	<u>444</u>	<u>(979)</u>
Total venting	774	(1 706)	1 218	(2 685)
Avg. vent rate per second from supply tank	0.34	(0.75)	0.535	(1.18)
Liquid pumped during maximum refuel				
Net liquid On board	29 090	(64 132)	29 090	(64 132)
Losses	0	(0)	444	(979)
Average pumping rate per second	12.76	(28.13)	12.95	(28.56)
$m^3/s$	0.1803		0.1830	
gpm		(2 858)		(2 901)

This is not the total LH<sub>2</sub> required for fueling the aircraft, however. There is a 665.0 kg (1466 lb) boil-off due to heat leak during ground time plus a 80.7 kg (178 lb) loss due to energy imparted to the LH<sub>2</sub> by the refuel pumps and a 305 kg (672 lb) refueling system loss. The latter loss is detailed in Table 4 and will be subsequently discussed. The sum of these losses, 1050.5 kg (2316 lb), is the total ground time loss which when added to the total mission requirements of 11 795 kg (26 003 lb) result in the overall liquid requirements of 12 845 kg (28 319 lb).

The overall liquid requirements may actually be somewhat less than the preceding quantity, which is based on LH<sub>2</sub> at saturation condition as it enters the aircraft fuel tank. However, the first several aircraft refueled from a full supply tank will receive subcooled liquid instead of saturated liquid, giving some opportunity to "save" some losses by warming the liquid rather than boiling it. With full subcooling in the LH<sub>2</sub> supply tank based on a 103.4 kPa (15 psia) pressure and with 114.8 kPa (21 psia) in the aircraft tank, losses will be reduced by 252 kg (555 lb), giving a net liquid per mission of 12 593 kg (27 764 lb). With warm liquid in the storage tank, total losses based on 11 340 kg (25 000 lb) net fuel to engines amount to 13.3% and with fully subcooled liquid they are 11.1%. Actual operation is probably represented by some intermediate condition as represented by the arithmetic average value of 12.2%.

The next portion of Table 1, presents the various sources of vent gas given off during refueling. There are 331 kg (731 lb) of vapor displaced by the 11 795 + 665 kg (26 003 + 1466 lb) of liquid which enters the fuel tank, plus 64.9 kg (143 lb) of vapor resulting from heat leak during the 38-min refueling period and 80.7 kg (178 lb) of vapor resulting from pump work. The total can be reduced by 251.7 kg (555 lb) if fueling was done with subcooled liquid. The total vent rate amounts to 412.3 kg (909 lb) if fueling from a cold supply tank and 664.0 kg (1464 lb) if fueling from a warm supply tank.

Table 1 also shows calculation of venting and pumping rates for a maximum refuel involving 29,090 kg (64,132 lb) of LH<sub>2</sub> loaded into the fuel tanks in 38 minutes. Calculations are presented for both cold and warm supply tanks. In the case of the cold supply tank, there is more than sufficient refrigeration in the subcooled liquid to overcome tank heat leak, piping losses and pump work so that the only vapor vented is the 773.8 kg (1706 lb) resulting from displacement. In the case of the warm supply tank, these additional losses add to the displacement vapor to produce a total venting rate of 1,218 kg (2685 lb). Over the 38 minute refueling period, the average vent rates are 0.34 kg/s (0.75 lb/sec) and 0.535 kg/s (1.18 lb/sec) respectively. Pumping rate from a warm supply tank, based on a total liquid quantity of 29 534 kg (65 111 lb), is 0.1830 m<sup>3</sup>/s (2,901 gpm).

## A2. ESTIMATION OF SUPPLY TANK PRESSURIZATION LOSSES

Table 2 shows calculation of losses in a large ground storage tank. These losses are a strong function of the manner in which the tank is used, ranging from a best case of 3.16% to 52.7%. The primary source of loss is the displacement vapor required either to provide NPSH for the refueling pumps or provide  $\Delta P$  for the refueling piping without a pump. This displacement vapor is obtained by vaporizing, external to the tank, a portion of the liquid in storage. The lowest possible loss is for an ideal operation which starts with a full cold tank and several aircraft are refueled by pumps in a short time until the tank is empty. Refueling would then switch to another full cold tank. The liquefier would make into (or vehicle would unload into) the tank(s) while they are not being used for refueling. The highest loss is for infrequent refueling of individual aircraft, requiring the tank to be blown down and repressurized each time. For a well-designed ground tank, heat leak is a very small part of the total loss. Pressure transfer for the estimated piping system gives a very high loss. If pressure transfer were actually used, all the pipe sizes should be increased to reduce tank losses (at the expense of increased piping system losses).

A basic problem is the need for subcooled liquid for several purposes.

- To provide pump NPSH,
- To maintain single phase flow in piping,
- To achieve minimum flashoff while refueling aircraft.

To accomplish these objectives, it is necessary to flash the liquefier make to as low a pressure as practical to get it as cold as possible. (103 kPa (15 psia) assumed for these calculations.) If the liquefier make is sent to a tank at elevated pressure, it can not be cooled to saturation at 103 kPa (15 psia) and the needed subcooling will not be available. For these reasons, it is necessary to make into a different tank than the one being used for refueling.

To obtain subcooling for whatever purpose, it is necessary to obtain a non-equilibrium gas phase pressure higher than the saturation pressure of the liquid. (34.5 kPa (5 psi) pump NPSH used for these calculations.) Whenever the gas phase is at higher pressure (warmer) than the saturation pressure of the liquid, it causes the liquid to warm up, first at the surface, and over a period of time, the entire mass of liquid warms to a new equilibrium. If the time of exposure to the non-equilibrium gas is kept very short, the warming of the liquid can be kept small. Under these conditions, much of the liquid can be removed "cold." When the layer of warm liquid reaches tank bottom, the total pressure must be increased to maintain subcooling for its removal. In these calculations, 172 kPa (25 psia) pressure was assumed for removal of 138 kPa (20 psia) saturated liquid during fast removal. When the liquid is removed slowly, the gas phase pressure must be continually increased as warmer liquid is removed. The increased pressure causes increased warming

TABLE 2. ESTIMATE OF SUPPLY TANK PRESSURIZATION LOSSES

	<u>SI</u>	<u>Customary</u>
Tank capacity	272,154 kg	(600 000 lb)
Pump NPSH	34.5 kPa	(5 psi)
Starting pressure full tank	103.4 kPa	(15 psia)
Pressurization to start pumping	137.9 kPa	(20 psia)
 Operating Method #1 - Quickly refuel several aircraft until tank is empty		
Saturation pressure in tank at end	137.9 kPa	(20 psia)
Total pressure for NPSH	172.4 kPa	(25 psia)
Displacement at 172.4 kPa (25 psia)	8 589 kg	(18 936 lb)
	3.156%	
 Operating Method #2 - Refuel aircraft one at a time		
First refueling from full tank		
Displacement at 137.9 kPa (20 psia)	272.3 kg	(600.4 lb)
	2.527%	
Last refueling to empty the tank		
LH <sub>2</sub> pumped	10 776.8 kg	(23 759 lb)
Displacement @ 137.9 kPa	272.3 kg	(600.4 lb)
Pressurize remainder of tank from 103.4 to 137.9 kPa		
261 377 kg portion @ (2.527% - 1.922%)	1 581.4 kg	(3 486.3 lb)
Remaining displacement for liquid converted to pressurizing gas (1.922%)	36.3 kg	(80.1 lb)
Total pressurizing liquid to gas	1 890.0 kg	(4 166.8 lb)
	17.538%	
Average of first and last Loss % (share each refueling)		10.032%
 Operating Method #3 - Pressure transfer		
Liquid would get too hot to allow method similar to #1. Therefore, tank is blown down between refuelings similar to #2.		
First Refueling from full tank		
Displacement at 304.1 kPa (44.1 psia)		5.719%
Last refueling to empty the tank		
LH <sub>2</sub> transferred	10 776.8 kg	(23 759 lb)
Displacement @ 304.1 kPa	616.3 kg	(1 358.8 lb)
Pressurize remainder 103.4 - 304.1 kPa (5.719 - 1.922)	9 924.5 kg	(21 879.9 lb)
Remaining displacement for liquid to pressurizing gas	206.5 kg	(455.2 lb)
Total pressurizing liquid to gas	10 747.3 kg	(23 693.9 lb)
		99.726%
		52.722%
Average of First and Last Loss		

If pressure transfer actually were used, probably would increase all pipe sizes to get lower pressure drop. At 202.7 kPa, the average of first and last loss would be 26.255%. This would require a 50% increase in all pipe diameters and approximately a 50% increase in piping system losses. If all pipe diameters were increased by a factor of 2.5 times, tank pressurizing losses would be the same as for the two pump operating methods, but without any pumps. Piping system losses would increase about 2.2 times.



of the remaining liquid. Because of this problem, it would not be possible to maintain liquid subcooled below the 145 kPa (21 psia) relief valve setting of the aircraft tank, for slow continuous removal of the liquid. For this reason, if there are not enough aircraft to be refueled to quickly empty a tank, it will be necessary to blow the tank down to re-establish cold liquid.

To evaluate the effect of the above problem, calculations were made for three different tank operating methods.

- Method No. 1 - Quick removal by pump of all liquid starting with a full tank at 103 kPa (15 psia) and ending with an empty tank at 172 kPa (25 psia). The last drop of liquid removed is subcooled at 138 kPa (20 psia). This is the most ideal possible operation and gives a 3.2% loss.
- Method No. 2 - Individual refueling of aircraft by pump over an extended period of time. The tank is pressurized to 138 kPa (20 psia) for each refueling and blown down to 103 kPa (15 psia) between refuelings. Losses amount to 10.0% based on averaging initial and final refuel losses.

Actual operations using pumps would probably be a combination of Methods 1 and 2, giving losses somewhere between.

- Method No. 3 - Pressure transfer refueling or refueling without pumps. Operation is similar to Method No. 2 in that the tank is blown down after each refueling. To maintain single phase flow in the piping without using pumps, the non-equilibrium pressure must be high enough to provide all the piping pressure drop. Assuming the same piping system that was used when pumping LH<sub>2</sub>, this pressure is about 203 kPa (29.4 psi) which is high enough to cause the liquid to warm faster and to a higher temperature. Saturation pressure below 145 kPa (21 psia) can not be maintained for continuous operation, no matter how fast. For this reason, only the one-at-a-time operation was calculated. The tank is pressurized to 304 kPa (44.1 psia) for each refueling, and blown down to 103 kPa (15 psia) between. This gives losses of 52.7%.

Obviously, larger piping would require less pressure drop, less gas phase pressure, and lower tank loss, at the expense of higher piping system losses and capital cost. Though no further calculations were made, the following estimates were made: A 50% increase in pipe sizes would reduce gas phase pressure to 202.7 kPa (2 atm) and losses to 26.3%. A 250% increase in pipe size to 50.8 cm and 101.6 cm vs 20.3 cm and 40.6 cm (20 in. and 40 in. vs 8 in. and 16 in.) would get pressures and tank losses into the same magnitude as with pumps. There would be a pressure transfer optimization among pipe size, tank size, etc., for specific refueling schedules. No optimized pressure transfer calculations were made, primarily because the pump transfer operation offers lower loss.

### A3. ESTIMATION OF VEHICLE LOSSES

Table 3 shows the calculation of losses incurred by highway trailers and railway tank cars running between two sets of large ground tanks. The following explanation covers details of the individual losses for trailer operations. On emptying the trailer contents into the receiving storage tanks, there will be a 3.156% loss, amounting to 111.6 kg (246 lb), to provide displacement vapor at 172.4 kPa (25 psia). There will be a 136.1 kg (300 lb) piping system loss and a 4.53 kg (10 lb) loss due to heat leak and vehicle motion. Because heat leak loss is a very small part of the overall loss, the effect of mileage over the 1.609-160.9 km (1-100 mi) distance is negligible and a representative average loss per trip was assigned. At the filling location, the only loss incurred is the 136.1 kg (300 lb) piping system loss. The filling displacement loss has already been accounted for in the emptying displacement loss and is presented here for the purpose of estimating vent gas rates during the filling operation.

Railcar losses (9%) are slightly less than trailer losses (11.8%) because the invariable losses in the piping system are spread over a greater quantity per load.

### A4. ESTIMATION OF LH<sub>2</sub> PIPING SYSTEM LOSSES

The piping system was not designed, but an estimate of the design was made to estimate losses. At the San Francisco airport, the arc-length of the 19 refueling gates is about 1829 m (6000 ft), and is about 1524 m (5000 ft) away from the large supply tanks. A staycold system is used to keep both the piping and the liquid in the piping cold. Each gate has individual staycold return to maximize the portion of the refueling gate supply piping which is kept cold. Three large storage tanks were used, each with the four 0.189 m<sup>3</sup>/s (3000 gpm) pumps required for peak refueling. Pump outage at peak periods would require supply from two tanks. Separate staycold pumps of 0.0505 m<sup>3</sup>/s (800 gpm) would be used to avoid pump work losses from running 0.189 m<sup>3</sup>/s (3000 gpm) pumps when there are no refuelings.\* The 0.0505 m<sup>3</sup>/s (800 gpm) flow comes from keeping the LH<sub>2</sub> saturated below 145 kPa (21 psia) at the gate end of the staycold system.

Table 4 presents a summary of the piping system losses from Table 5, which presents the estimate of the piping system components, lengths, etc., required. Typical parameters for heat leak, cooldown, etc., were used for ground-weight vacuum insulated piping. The on-board flight-weight piping was estimated at 1/4 the ground-weight cooldown loss, expecting lower mass. The largest loss is for the transient piping which cannot be kept cold between refuelings. At 70 refuelings per day, losses to keep the remainder of the piping system cold are nearly as great. The staycold losses actually are fixed and are not per-refueling. Half as many refuelings gives twice the loss each.

---

\*Note that this system was not used in the final design of the SFO facility (see section 4.5.3).

TABLE 3. ESTIMATED LOSSES IN VEHICLES  
MOVING BETWEEN LARGE TANKS

	<u>Trailer</u>		<u>Railcar</u>	
	<u>SI</u>	<u>Customary</u>	<u>SI</u>	<u>Customary</u>
Nominal capacity	3 536	(7 796)	7 581	(16 714)
<b>Emptying losses</b>				
Displacement at 172.4 kPa	112	(246)	244	(537)
Heat leak and motion loss at 0.5%/day	17.7	(39)	38	(84)
Share per trip	4.5	(10)	38	(84)
Piping system loss	136	(300)	181	(400)
Total, emptying loss	252	(556)	463	(1 021)
Net LH <sub>2</sub> delivered	3 284	(7 240)	7 118	(15 693)
<b>Filling</b>				
Piping system loss	136	(300)	181	(400)
Filling displacement at 103.4 kPa	68	(150)	142	(312)
Total, filling loss	136	(300)	181	(400)
Gross LH <sub>2</sub> to fill	3 672	(8 096)	7 763	(17 114)
Total Loss	388	(856)	645	(1 421)
%	11 823		9.055	

All tabulated values in following units

SI - kg

Customary - lb

Capacity of highway trailer - 49.97 m<sup>3</sup> (13 200 gal)

Capacity of railcar - 107.13 m<sup>3</sup> (28 300 gal)

TABLE 4. LIQUID HYDROGEN PIPING SYSTEM BOIL-OFF

<u>Description</u>	(SI UNITS)		<u>Factor</u>	<u>Boil-off</u> g/s	<u>Boil-off</u> kg/Refuel
	<u>Pipe</u> <u>Size</u> cm	<u>Equiv.</u> <u>Length</u> m			
Staycold return	2.54	3902.1	0.0411	3.844	
Staycold return	10.16	5430.1	0.109	14.189	
Staycold supply	20.32	6042.0	0.212	30.670	
Staycold supply	40.64	5288.0	0.420	53.232	
Total Staycold				101.936	
@ 70 refuelings per day					125.8
Transient piping					
Heat leak 38 minutes	20.32	251			9.0
Cooldown 38 minutes	20.32	47.6			141.6
Total transient					150.6
Piping boil-off per refueling					
@70 per day					276.4
Pump work to run staycold System (203.4 kPa, 3.03 m <sup>3</sup> / min)				22.889	23.7
Transient piping portion on board aircraft					
Heat leak 38 minutes		170.1			6.1
Cooldown 38 minutes		20.0			59.4
Total					65.5

TABLE 4. (Continued)

(CUSTOMARY UNITS)

<u>Description</u>	<u>Pipe Size Inches</u>	<u>Length Feet</u>	<u>Factor Btu/hr-ft</u>	<u>Boil-off lb/Day</u>	<u>Boil-off lb/Refuel</u>
Staycold return	(1)	(12 802.2)	(0.46)	(732.3)	
Staycold return	(4)	(17 815.4)	(1.22)	(2 702.8)	
Staycold supply	(8)	(19 822.7)	(2.37)	(5 842.0)	
Staycold supply	(16)	(17 349.0)	(4.7)	(10 139.7)	
Total staycold				(19 416.8)	
@ 70 Refuelings per day					(277.4)
Transient piping					
Heat leak 38 minutes	(8)	(823)	(2.37*3.05)		(19.8)
Cooldown 38 minutes	(8)	(156.1)	(395 Btu/ ft*0.96)		(312.2)
Total transient					(332.0)
Piping boil-off per refueling					
@ 70/day					(609.4)
Pump work to run staycold system (29.5 psi, 800 gpm)				(4 360)	(62.3)
					(671.7)
Transient piping portion on board aircraft					
Heat leak 38 minutes		(558.0)			(13.4)
Cooldown 38 minutes		(65.5)			(131.0)
					(144.4)

TABLE 5. ESTIMATE OF LOSSES IN LIQUID HYDROGEN PIPING SYSTEM

		Heat Leak		Pressure Drop	
		Length Factor	Equiv. Feet	Length Factor	Equiv. Feet
Refueling Pump Piping	(12 req'd) ea				
Suction 8 in.			(for 12)		
Straight	30 ft	1	360	1	30
Ells	2	3.1	74.4	9.2	18.4
Hose	3 ft	3.1	111.6	28	84
Coupling	1	50	600	0	0
Valve	1	50.6	607.2	112.4	112.4
Joints	7	12.5	1050	0	0
Discharge 8 in.					
Straight	20 ft	1	240	1	20
Ells	3	3.1	111.6	9.2	27.6
Hose	3 ft	3.1	111.6	28	84
Coupling	1	50	600	0	0
Valve	2	50.6	1214.4	112.4 (*1)	112.4
Tee	2	4.6	110.4	10.8	47.6
Joints	12	12.5	1800	36.8	0
Priming 8 in.					
Straight	100 ft	1	1200	1 (*0)	0
Ells	4	3.1	148.8	9.2	0
Joints	9	12.5	1350	0	0
Total for Refueling Pumps			9690.0		536.4
Common Piping Set of 4 Pumps	(3 req'd) ea		(for 3)		
Straight	150 ft	1	450	1 (*2/3)	100
Ells	1	3	9	15	15
Tees	2	4	24	70	140
Valve	1	60	180	250	250
Joints	20	12	720	0	0

TABLE 5 (Continued)

		Heat Leak		Pressure Drop	
		Length Factor	Equiv. Feet	Length Factor	Equiv. Feet
Set of 3 Tanks - Common 16 in.		(for 1)			
	ea				
Straight	400 ft	1	400	1 (*1/2)	200
Ell	2	3	6	15	30
Tee	1	4	4	70	70
Joints	17	12	204	0	0
Supply Line 16 in.					
Straight	5000 ft	1	5 000	1	5000
Ells	8	3	24	15	120
Joints	141	12	1 692	0	0
Distribution Header - 16 in.					
Straight	6000 ft	1	6 000	1 (*1/2)	3000
Ells	20	3	60	15 (*1/2)	150
Valves	4	50	200	250 (*1/2)	500
Joints	198	12	2 376	0	0
Total 16 in. Piping			17 349	9575	
Refueling Station 8 in. (19 Req'd)					
Ground Stay Cold 8 in.		ea			
Straight	200 ft	1	200	1	200
Ell	4	3.1	12.4	9.2	36.8
Tee 16 x 8	1	4	4	36.8	36.8
Valve	1	50	50	112.4	112.4
Filter	1	16.9	16.9	35	35
Joints	20	12.5	250	0	0
Total each			533.3	421.0	
Total for 19			10 132.7	-	

TABLE 5 (Continued)

		Heat Leak		Pressure Drop	
		Length Factor	Equiv. Feet	Length Factor	Equiv. Feet
Stay Cold Return Piping (19 Req'd) at Refueling Station 1 in. ea			(for 19)	1	200
Straight	200 ft	1	3 800	1	200
Ell	4	5.0	380	1.9	7.6
Tee	1	7.4	140.6	5.8	5.8
Valve	1	15.2	288.8	14.5	14.5
Joints	22	19.6	8 192.8	0	0
Total 1 in. Staycold			12 802.2		227.9
Distribution Header 4 in.					
Straight	6000 ft	1	6 000	1 (*1/2)	3000
Ell	20	3.6	72	5.2 (*1/2)	52
Valve	4	43.1	172.4	52.1 (*1/2)	104.2
Joint	198	14.3	2 831.4	0	0
			9 075.8		3156.2
Return Line 4 in.					
Straight	5000 ft	1	5 000	1	5000
Ell	8	3.6	28.8	5.2	41.6
Joint	141	14.3	2 016.3	0	0
			7 045.1		5041.6
At 3 Tanks 4 in.					
Straight	700 ft	1	700	1 (*1/2)	350
Ell	12	3.6	43.2	5.2	20.8
Tee	4	5.3	21.2	19.8 (*1/2)	39.6
Valve	3	43.1	129.3	52.1 (*1/3)	52.1
Joint	56	14.3	800.8	0	0
			1 694.5		462.5
Total 4 in. Staycold			17 815.4		8660.3



TABLE 5 (Continued)

	Cooldown		Heat Leak		Pressure Drop		
	Length Factor	Equiv. Feet	Length Factor	Equiv. Feet	Length Factor	Equiv. Feet	
Ground Transient 8 in.							
Straight	50 ft	1	50	1	50	1	50
Ell	3	3	9	3	9	9.2	27.6
Hoses	10 ft	1.85	18.5	3.1	31	28	280
Coupling 1/2	1	4	4	25	25	0	0
Valve	1	9.1	9.1	50	50	112.4	112.4
Joints	8	0	0	12.5	100	0	0
On Board Transient 8 in.							
Straight	200 ft	1(*1/4)	50	1	200	1	200
Ell	6	3(*1/4)	4.5	3.1	18.6	9.2	55.2
Tee	3	3.3(*1/4)	2.5	4.6	13.2	10.8 *1}	84.4
						36.8 *2}	
Valve	2	9.1(*1/4)	4.5	50.6	101.2	112.4	224.8
Joints	16	0	0	12.5	200	0	0
Coupling 1/2	1	4	4	25	25	0	0
Total Transient			156.1		823		1034.4



## APPENDIX B

### SAFETY CONSIDERATIONS

#### B1. DISTANCE STANDARDS

Standards are customarily promulgated for the location and separation of process and storage equipment for flammable liquids. Thus the National Fire Protection Association has issued the following standards which contain such specifications.

NFPA No. 59	For the Storage and Handling of Liquefied Petroleum Gases at Utility Gas Plants.
NFPA No. 59A	For the Production, Storage and Handling of Liquefied Natural Gas (LNG).
NFPA No. 50A	For Gaseous Hydrogen Systems at Consumer Sites.
NFPA No. 50B	For Liquefied Hydrogen Systems at Consumer Sites.

It would appear that standards already exist for hydrogen storage but the two standards cited are intended for small scale usage at consumer sites and both specifically exempt manufacturing plants or other establishments operated by the hydrogen supplier for the purpose of storing hydrogen and filling operations. The minimum distances given in Standard NFPA 50B are limited to storage capacities of no more than 113.6 m<sup>3</sup> (30 000 gal) which is too small by a factor of 33 for the present application, and clearly new values must be established for the larger storage capacities. However, the minimum distances given in the existing NFPA Standards may, if used judiciously, serve as a guide.

In establishing clearance distances for storage vessels, recognition should be given to the reciprocal nature of the potential hazard. Very often the surrounding environment presents a greater hazard to the storage tank than the tank presents to its surroundings. Thus, quoting from NFPA No. 95 concerning location of refrigerated LPG containers: "Such a container or containers shall be 30.5 m (100 feet) or more from above ground storage of flammable liquids and from any buildings of such construction or occupancy which constitute a material hazard of exposure to the containers in the event of fire or explosion in said buildings."

The extent of hazard resulting from an LH<sub>2</sub> spill is dependent not only on its proximity to storage tanks, buildings, concentrations of people, etc., but also on the size of the spill and whether the hydrogen ignites. Obviously, the greater the quantity that is spilled, the greater the hazard upon ignition, and the greater should be the clearance. Hydrogen has a very low ignition energy and will ignite more readily than other combustibles. Hydrogen also has very wide combustibility limits in air (4.1 to 74.2%). Consequently, it must be assumed that fire accompanying a spill will be the rule rather than the exception. On the other hand, an unconfined hydrogen-air mixture will ignite in a deflagration, not a detonation. This means that blast damage will be minimal. The resulting hydrogen flame is invisible and has a temperature of about 2317 K (3710° F). Despite the high temperature, the flame has a low emissivity and will radiate energy at a rate which is about 10 percent of that from gasoline and other hydrocarbon fires. Radiation effects on nearby equipment will not be as severe and clearances need not be as great. Also because of its high volatility, an LH<sub>2</sub> spill will vaporize rapidly and the resulting fire will not be of as long duration as an equal spill of hydrocarbon liquid.

Employing the preceding guidelines, the clearances recommended for process equipment and storage tanks for installation at SFO are given in Table B-1. The distances specifically apply to liquid hydrogen storage vessels. They may also be used for the vacuum jacketed piping which comprises the fueling system because it contains a considerable quantity of stored liquid hydrogen. For example, the 6706 m (22 000 ft) of 25.4 cm (10 in.) diameter supply distribution piping (2 lines) plus the same length of 7.6 cm (3 in.) diameter return piping (2 lines) will contain 411 m<sup>3</sup> (108 00 gal) of LH<sub>2</sub>. The possibility that a spill of this magnitude will occur in the event of pipeline rupture must be assumed.

The comparative distances (NFPA 59A) for LNG storage containers is "0.7 times the container diameter but not less than 30.5 m (100 feet)." between container and property line which may be built upon, and "1/4 of sum of diameters of adjacent containers but not less than 8.5 m (25 feet)." between adjacent containers.

#### B1.1 Process Equipment

Process equipment containing liquid hydrogen or gaseous hydrogen shall be located at least 15.2 m (50 ft) from sources of ignition, a property line which may be built upon, control rooms offices, shops and other occupied structures.

For refrigerated LPG containers (NFPA 59), the specified distance "from container to nearest important building, or group of buildings, not associated with the LP-Gas plant, or a line of adjoining property which may be built upon" is 91.4 m (300 ft) for storage capacities of 757.1 - 3785.4 m<sup>3</sup>

TABLE B-1. RECOMMENDED CLEARANCES FOR LH<sub>2</sub> STORAGE TANKS AND PROCESS EQUIPMENT INSTALLED AT SAN FRANCISCO AIRPORT

		Liquefied Hydrogen Storage					
		SI	Customary	SI	Customary	SI	Customary
Type of Exposure	Quantity	265	(70 000)	473	(125 000)	757	(200 000)
	m <sup>3</sup> (gal)	to	to	to	to	to	to
Distances in meters (ft)		473	(125 000)	757	(200 000)	3785	(1 000 000)
Building		30.5	(100)	47.5	(150)	61.0	(200)
Flammable liquids		30.5	(100)	45.7	(150)	61.0	(200)
Between LH <sub>2</sub> containers		(1)		(1)		(1)	
Combustible solids		30.5	(100)	45.7	(150)	61.0	(200)
Open flames, smoking, welding		30.5	(100)	45.7	(150)	61.0	(200)
Concentrations of people		30.5	(100)	45.7	(150)	61.0	(200)
Public ways and property lines		30.5	(100)	45.7	(150)	61.0	(200)

(1) 1/4 the sum of diameters of adjacent containers but not less than 30.5 meters (100 ft).

(200 001 - 1 000 000 gal) and 61.0 m (200 ft) for storage capacities of 473.2 - 757.1 m<sup>3</sup> (125 001 - 200 000 gal). There is further specification that containers having a capacity in excess of 454 m<sup>3</sup> (120 000 gal) shall be located 30.5 m (100 ft) from buildings containing process equipment or "from outdoor installations essential to the maintenance of operation in such buildings". Also, "Such a container or containers shall be 100 feet or more from above ground storage of flammable liquids and from any buildings of such construction or occupancy which constitute a material hazard of exposure to the containers in the event of fire or explosion in such buildings." This is an example of providing separation to protect storage tanks due to potential hazard from external source.

For spacing of process equipment, the recommended distance between such equipment containing liquid hydrogen or gaseous hydrogen and sources of ignition, a property line which may be built upon, control rooms, offices, shops and other occupied structures shall be at least 15.2 m (50 ft).

It is felt that the recommended minimum distances represent a satisfactory and possibly a somewhat conservative set of values when judged in comparison with existing NFPA standards for LH<sub>2</sub>, LNG and LPG. A certain amount of conservatism is probably prudent for the initial installation and distances can be readjusted, if necessary, as experience is gained and more information becomes available.

## B2. MATERIALS OF CONSTRUCTION

### B2.1 General Considerations

Selection of suitable materials for hydrogen service is based upon three principal criteria.

- a. The material must be sufficiently ductile for use at liquid hydrogen temperatures (20.4 K).
- b. The material must permit fabrication of equipment for which leakage is minimum.
- c. The material must be resistant to elevated temperatures in the event of fire.

Materials which retain their ductility at LH<sub>2</sub> temperatures and are approved include the austenitic stainless steels (300 series) copper, monel, bronze, brass and aluminum. The stainless steels are preferred and are used most extensively. Aluminum is not generally satisfactory for applications other than liquid containers or portions of a liquid system which are covered by a suitable vacuum jacket or enclosed in an insulated cold box. The intent is to maintain system integrity in the event that the equipment is

exposed to a large fire. The relatively low melting point for aluminum could result in piping or vessel failure because of the fire and result in the release of additional large quantities of fuel. For a system of the size projected for this application, a series of incidents could snowball with catastrophic results.

Gasketing materials should be of asbestos base such as Durabla or other noncombustible material. Nylon, Teflon, or rubber are not recommended because of their tendency to burn or deform at elevated temperatures.

Arc welded or Heliarc welded joints are preferred for all cases. Welded joints should be subsequently heat treated to avoid embrittlement. Soft soldered joints are completely unacceptable and silver brazed joints are not recommended for pressurized piping or vessels.

## B2.2 Insulated Liquid Piping

All insulated liquid lines shall be of the vacuum jacketed type installed in accordance with the manufacturer's specifications and recommendations. Other types of installation such as styrofoam, foamglass, polyurethane, etc., present a safety hazard when used to insulate liquid hydrogen lines. Because of the difficulty in forming a completely effective barrier against air diffusion, such insulation systems may accumulate a condensed layer of permeated air on the surface. Upon vaporization of the condensed air, the nitrogen will preferentially boil off leaving a residual atmosphere enriched in oxygen. With a flammable insulation or in the event of a piping leak an explosive mixture may result in or under the insulation.

## B2.3 Uninsulated Liquid and Cold Gas Piping

Uninsulated piping must be kept to a minimum because of a severe heat leak penalty associated with its use. Such piping shall be of stainless steel using welded construction. Flanged joints or screwed unions should not be used and neither should threaded connections. Valves shall have extended stems with weld ends. Aluminum piping and copper tubing with silver brazed joints should not be used. Soft soldered joints must be avoided. These rules should not be compromised because a hydrogen fire impinging upon such joints could melt out the solder or silver braze, increase the leakage and result in an uncontrollable fire.

The primary isolation valve which isolates the source of  $LH_2$  with the rest of the system and all valves that cannot be removed from service by closing the primary isolation valve should have metal-to-metal seats to prevent seat failure in the event of fire.

Valve packings for hydrogen service should be of a material which will not melt or burn. This is another precaution against uncontrolled leakage in event of fire. Asbestos impregnated with Teflon is a very satisfactory material for this purpose.

## B2.4 Warm Gaseous Hydrogen Piping

Warm gas lines shall be threaded brass or threaded or welded carbon steel or stainless steel pipe. Aluminum piping and copper tubing with silver brazed connections should be avoided. Threaded construction, however, should be kept at a minimum because of the propensity for hydrogen to leak through such joints. When used, threaded joints should be sweat-soft-soldered or sealed with a bead of silver solder around the thread after the connection is made up tight.

## B3. VENTILATION REQUIREMENTS

NFPA Standard No. 50B does not permit indoor storage of quantities of liquid hydrogen in excess of 2.271 m<sup>3</sup> (600 gal). Most of the SFO fueling operations involve much larger quantities of LH<sub>2</sub> and consequently most operations are outdoors. Smaller quantities may be located in buildings and such situations are covered by Sections 521, 531 and 622 of the standard.

NFPA Standard No. 50A permits quantities of gaseous hydrogen in excess of 424.8 m<sup>3</sup> (15 000 cf) to be used only outdoors or in a separate building. Only quantities less than 85.0 m<sup>3</sup> (3000 cf) may be located inside general buildings and such situations are covered by Sections 521 and 622 of this standard.

Section 622 relates to ventilation requirements and is the same for both standards. It is repeated verbatim and in its entirety, as follows: "Adequate ventilation to the outdoors shall be provided. Inlet openings shall be located near the floor in exterior walls only. Outlet openings shall be located at the high point of the room in exterior walls or roof. Inlet and outlet openings shall each have a minimum total area of one square foot per 28.3 m<sup>3</sup> (1000 ft<sup>3</sup>) of room volume. Discharge from outlet openings shall be directed or conducted to a safe location."

## B4. ELECTRICAL SYSTEM PROTECTION

NFPA Standard No. 50B covers electrical system requirements for liquid hydrogen systems under Sections 491, 492 and 4101. The first two sections require compliance with the National Electrical Code, as follows:

491. "Electrical wiring and equipment located within 3 feet of a point where connections are regularly made and disconnected, shall be in accordance with Article 501 of the National Electrical Code, NFPA No. 70, for Class I, Group B, Division 1 locations."

492. "Except as provided in 491, electrical wiring and equipment located within 25 feet of a point where connections are regularly made and disconnected or within 25 feet of a liquid hydrogen storage container, shall be in accordance with Article 501 of the National Electrical Code, NFPA No. 70, for Class I, Group B, Division 2 locations."



When equipment approved for Class I, Group B atmospheres is not commercially available, the equipment may be (1) purged or ventilated in accordance with NFPA No. 496, Standard for Purged Enclosures for Electrical Equipment in Hazardous Locations, or (2) intrinsically safe or (3) approved for Class I, Group C atmospheres. This requirement does not apply to electrical equipment which is installed on mobile supply trucks or tank cars from which the storage container is filled."

Section 4101 relates to bonding and grounding.

4101. "The liquefied hydrogen container and associated piping shall be electrically bonded and grounded."

This regulation is for the purpose of preventing fires caused by sparks originating from differences in electrical potential between two pieces of equipment. Because of its low ignition energy, hydrogen is readily ignited by a spark. A spark energy of 0.02 mj is claimed (Ref. 11) to be sufficient to ignite a stoichiometric hydrogen-air mixture. The most likely cause of electrical charge is static electricity which is generated by the action of contact and separation of dissimilar materials. In any flow system involving combustible fluids, one cannot afford the assumption that static charges do not exist and must, accordingly, make provision for draining them away. Therefore, every piece of process equipment, every storage tank, and every other system component must be attached to an adequate grounding system. All gasketed pipeline joints must be bridged with an electrically conductive bonding strap. Any piece of equipment which is not normally grounded and which is to be connected to the hydrogen system must first be electrically connected by suitable means such as a wire cable and alligator clip. This applies especially to the LH<sub>2</sub> hydrant fueling truck which must be grounded before making hydrant connections and again at the aircraft which must be grounded before connecting the fueling lines. Personnel engaged in making and breaking the fueling line connections must have provision for grounding themselves such as conductive-sole shoes. Clothing which tends to accumulate static charges (e.g., synthetic fabrics) should be avoided.

The importance of electrical grounding cannot be overemphasized. To compromise on a ground which is less than entirely adequate is to introduce the potential risk of ignition caused by static discharge resulting in a serious fire.

## B5. GAS DISPOSAL SYSTEMS

### B5.1 Vent Stacks

Vent stacks should be provided for the disposal of small quantities of hydrogen gas which may be vented from time to time. Examples include vented gas from safety valves, rupture discs, blowdown valves, etc. The various vent lines leading from such sources should terminate in a vent stack which is at least 7 feet above all equipment and buildings within a 15.2 m (50 ft) radius of the stack, and higher than any wall opening within a 22.9 m (75 ft) radius. The stack and interconnecting piping should be sized to accommodate

the maximum flow which must be vented in any conceivable situation. The length to diameter ratio for the stack must not exceed 60:1. The stack should be located so that prevailing winds do not carry the effluent from the stack to a hazardous area.

## B5.2 Flare Stacks

For disposal of abnormal quantities of hydrogen, simple vent stacks are inadequate to accomplish the job in a safe manner. For release of quantities in excess of 0.454 kg/s (1 lb/s), disposal is best handled by means of a burn-off system in which the liquid or gas is piped to a distant location and burned in a suitable flare. The installation should include adequate monitoring for flame-out protection and means for purging the line. A check valve arrangement should be provided in the line to prevent back-diffusion of air.

A burn lagoon such as is used at Cape Kennedy for disposal of very high volume rates of  $\text{GH}_2$  is not deemed to be necessary.

## B6. FIRE PROTECTION

The most effective way to combat a hydrogen fire is to allow it to burn itself out. If at all possible, the flow of hydrogen should be shut off by closing a valve between the fire and the source of hydrogen. Attempts should not be made to extinguish the flame by use of water or other extinguishing agents because the hydrogen is certain to reignite, possibly with explosive violence if it has mixed with air in sufficient amount. This is likely to cause more damage than the fire.

Fire protection systems are necessary, however. The purpose of the water system is to control the spread of the fire; it should not be used to attempt to extinguish the hydrogen flame. A water distribution system for fire fighting purposes must be provided with fire hydrants spaced at distances no greater than 37 m (120 feet) apart throughout the liquefaction/storage site. A standard fire hose equipped with a suitable nozzle and attached to the hydrant is recommended.

Deluge systems are not recommended. The principal fire protection which has been provided is the separation of equipment by suitable distance and an adequate water-hydrant system which can be used by fire fighting personnel to cool down adjacent equipment and prevent spread of the fire.

Water hydrant outlets are recommended at each fueling gate. These should not be located in the fueling hydrant pit, however, because they would be inaccessible in the event of fire at that location. Each mobil  $\text{LH}_2$  hydrant fueling truck should be provided with all-purpose, powder-type fire extinguishing equipment for the purpose of combatting small fires, other than hydrogen, that may occur in fueling operations.

The  $\text{LH}_2$  storage tanks should be equipped with remotely controlled isolation valves at the outlet of each tank and as close to the tank as possible to permit shutting off the supply of liquid hydrogen in case of fire. The

valves should be installed for fail-safe operation to close upon loss of motive power.

Monitoring equipment may be used for detecting either hydrogen leaks or hydrogen fires. Leak detection monitoring need normally be applied only in confined spaces where air-hydrogen mixtures may accumulate, such as buildings and control rooms. The principal commercial instrument for leak detection is the catalytic combustion detector which is available in a number of types from several vendors. It serves the purpose of analyzing an air-hydrogen mixture and reporting the composition in relation to the lower explosive limit. This instrument can be provided with visual readout and audible alarm. In outdoor locations where leakage hydrogen can readily dissipate, such monitoring is considered to be superfluous.

The need for hydrogen fire detectors is considered by many hydrogen users to be not as great as that for hydrogen leak detectors. One likely reason for this attitude is an experience record in which hydrogen fires are not a serious problem. Those that do occur as a result of leaks are usually small and do little damage. Another reason may be a lack of suitable detectors that are convenient, economical and reliable. For situations where fire detection monitoring is desired, the ultraviolet sensor is preferred. Infrared television detectors are also available and are useful for obtaining visual flame images although visualization by such mundane techniques as throwing solid materials into the flame can be obtained at a much lower cost. Thermal detectors may also be used and they are reliable, more common and less costly than the optical type detector. They have the disadvantage that to be effective they must be located near the fire if a serious time lag is not to be incurred. For effective monitoring, therefore, a large network of detectors must be used.

For the liquefaction/storage complex a major attempt at fire detection does not seem to be warranted. For a few strategic locations where a fire could result in major damage to the facility installation of thermal detectors with suitable visual/audible alarms can be used.



## REFERENCES

1. Brewer, G. D.: Final Report: Advanced Supersonic Technology Concept Study - Hydrogen Fueled Configuration. NASA CR-114718, Lockheed-California Company, January 1974.
2. Brewer, G. D., Morris, R. E., Lange, R. H., Moore, J. W.: Final Report: Study of the Application of Hydrogen Fuel to Long Range Subsonic Transport Aircraft. NASA CR-132559, Lockheed-California Company for Langley Research Center, January 1975.
3. Brewer, G. D.: and Morris, R. E.: Final Report: Minimum Energy, Liquid Hydrogen Supersonic Cruise Vehicle Study, NASA CR-137776, Lockheed-California Co., October 1975.
4. Brewer, G. D.: and Morris, R. E.: Final Report: Study of LH<sub>2</sub> Fueled Subsonic Passenger Transport Aircraft, NASA CR-144935, Lockheed-California Co., January 1976.
5. Anon., ATA Airport Demand Forecast, San Francisco Hub Airport, Air Transport Association of America, October 1975.
6. Anon., Official Airline Guide, North American Edition, August 15, 1973, A Reuben H. Donnelly Publication, Oak Brook, Illinois.
7. Survey Study of the Efficiency and Economics of Hydrogen Liquefaction, NASA CR-132631, April 8, 1975, Contract NAS1-13395, by Linde Division of Union Carbide Corp.
8. Studies Made on Aircraft Moving, Airports International, No. 49, June/July 1975, p. 33.
9. "Flight Deck Control of Tractor Proposed," Airports International, June/July 1975, p. 34.
10. "The Ralph M. Parsons Company: The Apron and Terminal Building Planning Manual, DOT-FA-72WA 2950 MOD 2, July 1975.
11. Gromer, J.: Strasser, A.: and Van Meter, R. A.: Principles for Safe Handling of Liquid Hydrogen, Technical Report, U.S. Bureau of Mines, Explosive Research Center, April 1967.