

## NEUTRAL ELASTIC DEFORMATIONS

Metin M. Durum

Roy C. Ingersoll Research Center, Borg-Warner Corp.

### ABSTRACT

Elastic bodies or systems may not require external energy for certain finite and continuous deformations. Conditions providing these kinds of effortless, or neutral, deformations are the subject of this paper.

### INTRODUCTION

If the total strain energy in a solid body or system remains constant during its elastic deformation, a neutral equilibrium state is obtained. No external effort then is needed for this deformation assuming the supports or guides are frictionless. If friction is considered during such a deformation, then the losses due to friction would introduce the only demand for external effort. Although an elasticity approach to determine the strain energy level would be extremely difficult for large deformations, simplified approaches such as beam or shell theories offer practical solutions.

Time independent stress or strain fields in Eulerian coordinates may be the simplest form of neutral deformation. In this special case, a stress or strain dependent boundary also remains fixed, and the deformation takes place in a rigid envelope similar to a steady fluid flow. These non-apparent deformations can be identified by inspection as illustrated in the following examples. It is generally not difficult to determine whether or not the macroscopic condition of a system, and consequently its stress field, are time independent.

### PRACTICAL EXAMPLES FOR NEUTRAL DEFORMATIONS

#### Flexible Shaft and a Spinor Problem

An initially straight, flexible shaft or rod having cross sections of equal principal moments of inertia and being guided or supported along a fixed curve can be rotated freely about its deformed axis (fig. 1). During this deformation, the stress distribution in the rod (not necessarily prismatic) is generally time dependent. However, since the bending stiffness around any cross section is constant, the deformed

rod axis (elastica) and, consequently, the total strain energy remain time independent within the approximations of beam theory. The stress distribution also becomes time independent if the rod is axisymmetrical. A steady torque transmission through a guided flexible shaft does not change the foregoing discussion, and the deformation still remains neutral.

As an aside, it can be noted that if the angular velocity vectors at A and B ends are collinear and in opposite direction ( $\omega_B = -\omega_A$ ) and if the supports' frame is rotated by  $\Omega_F = -\omega_A$ , then the absolute velocities become  $\Omega_A = 0$  and  $\Omega_B = -2\omega_A = 2\Omega_F$ . This spinor problem (ref. 1) was employed to provide a direct connection between a rotating and a fixed platform which was patented in 1971 (ref. 2).

### Free Invertible Rings

If the free ends A and B of a flexible rod are bonded together, a free invertible ring is obtained. Without the guides, the ring becomes circular (fig. 2).

A free invertible ring can also be obtained by bonding two molded rings of certain cross sections (such as semi circular sections) after inverting one through  $180^\circ$  (fig. 3). The split ring idea was applied to rollable belts and patented in 1928 (ref. 3).

In general, the uniform inversion of a non-strained slender ring about a given circular axis requires a uniformly distributed torque and a uniformly distributed radial load. The torque is a sum of the first and second harmonic functions of toroidal displacement ( $\theta$ ) while the radial load is a first harmonic function of toroidal displacement (ref. 4 and author's disclosure, Oct. 1973). When two bonded rings are being inverted about their common circular axis, the second harmonic torques can be eliminated by a suitable choice of cross sections. Also, the sum of the first harmonic torques on the radial loads can be eliminated by introducing a difference of  $180^\circ$  between the inversion phases of the two rings.

### Belt and Pulleys

During a steady load transmission, the stress distribution in a uniform belt (fig. 4) remains the same, ignoring non-elastic properties of conventional belt materials. The deformation of this belt can, therefore, be called neutral. In this system, load transmission requires friction between the belt and pulleys, but then the microslips at their contacts produce an unavoidable small resistance.

If a belt of non-uniform stiffness is considered, its deformation will no longer be neutral.

### Rolamite (ref. 5)

Two rollers wrapped by a flat band move almost freely between parallel guides (fig. 5). The pretensioned elastic band presents constant stress and strain energy level in the straight portions (AB + CD) and time independent stress distribution in the wrapped portion (BC).

### Rolling Elements

Stress distribution in load-carrying rolling elements such as locomotive wheels remains constant in a transported frame. A small rolling resistance accompanies their neutral deformation, but this is mainly due to microslips at wheel-track contacts (ref. 6).

Some common load-carrying elements, e.g. radial ball bearings, undergo a non-neutral deformation because of a cyclic load and stress variation at ball-race contacts.

## CONCLUSION

A neutral deformation concept is defined, and two basic rules are employed to identify a large deformation of this kind with or without help of additional assumptions. Some practical applications have been presented. It is hoped that further investigations in this field may lead to new developments.

## REFERENCES

1. Adams, D. A., 'Direct Energy Communication Between Continuously Rotating and Stationary Platforms', U.S. Patent 3,586,413, June 22, 1971.
2. Bolker, E. D., 'The Spinor Spanner', American Mathematical Monthly, Nov. 1973.
3. Keiser, A. J., 'Feeding or Displacing Belt', U.S. Patent 1,667,120, April 24, 1928.
4. Biezeno & Grammel, 'Engineering Dynamics', Vol. II, Blackie & Son, Ltd., 1956.
5. Wilkes, D. F., 'Rolamite - A New Mechanical Design Concept', Research Report, Sandia Lab., Oct. 1967.
6. Poritsky, H., 'Microslip and Creep in Contacts', Interdisciplinary Approach to the Lubrication of Concentrated Contacts, NASA SP-237, 1970.

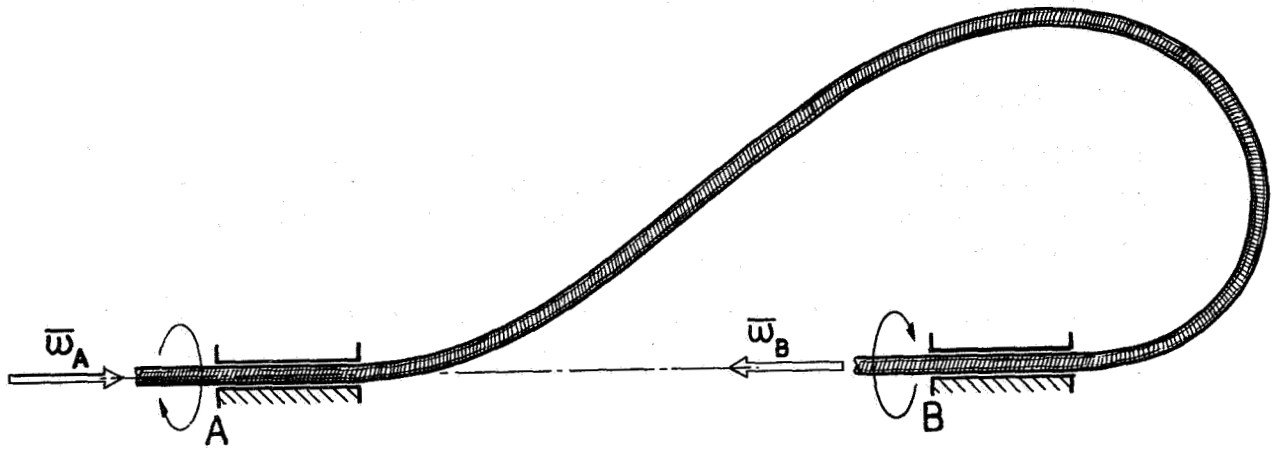

Figure 1.- Flexible shaft.

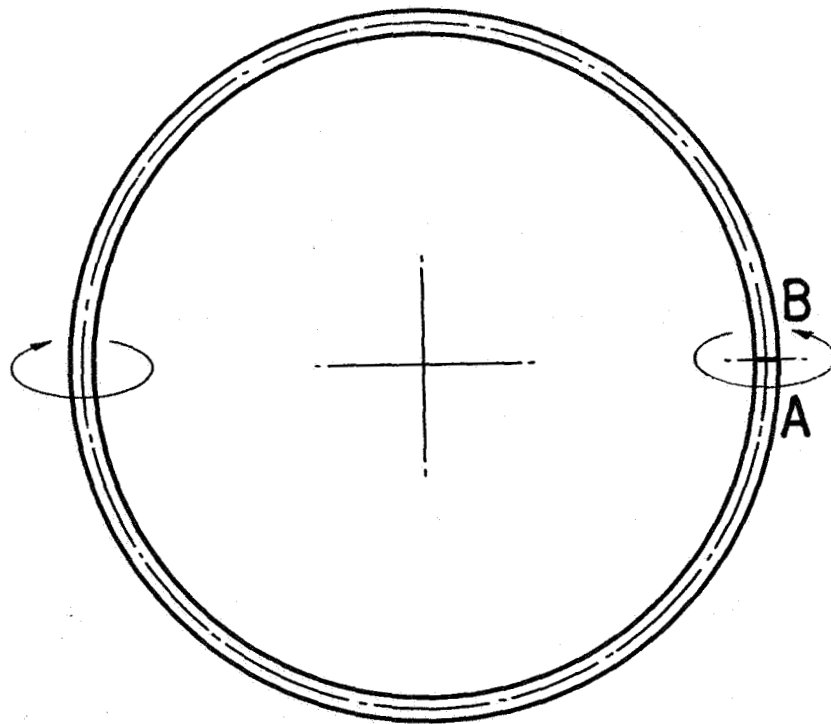

Figure 2.- Ring made of rod.

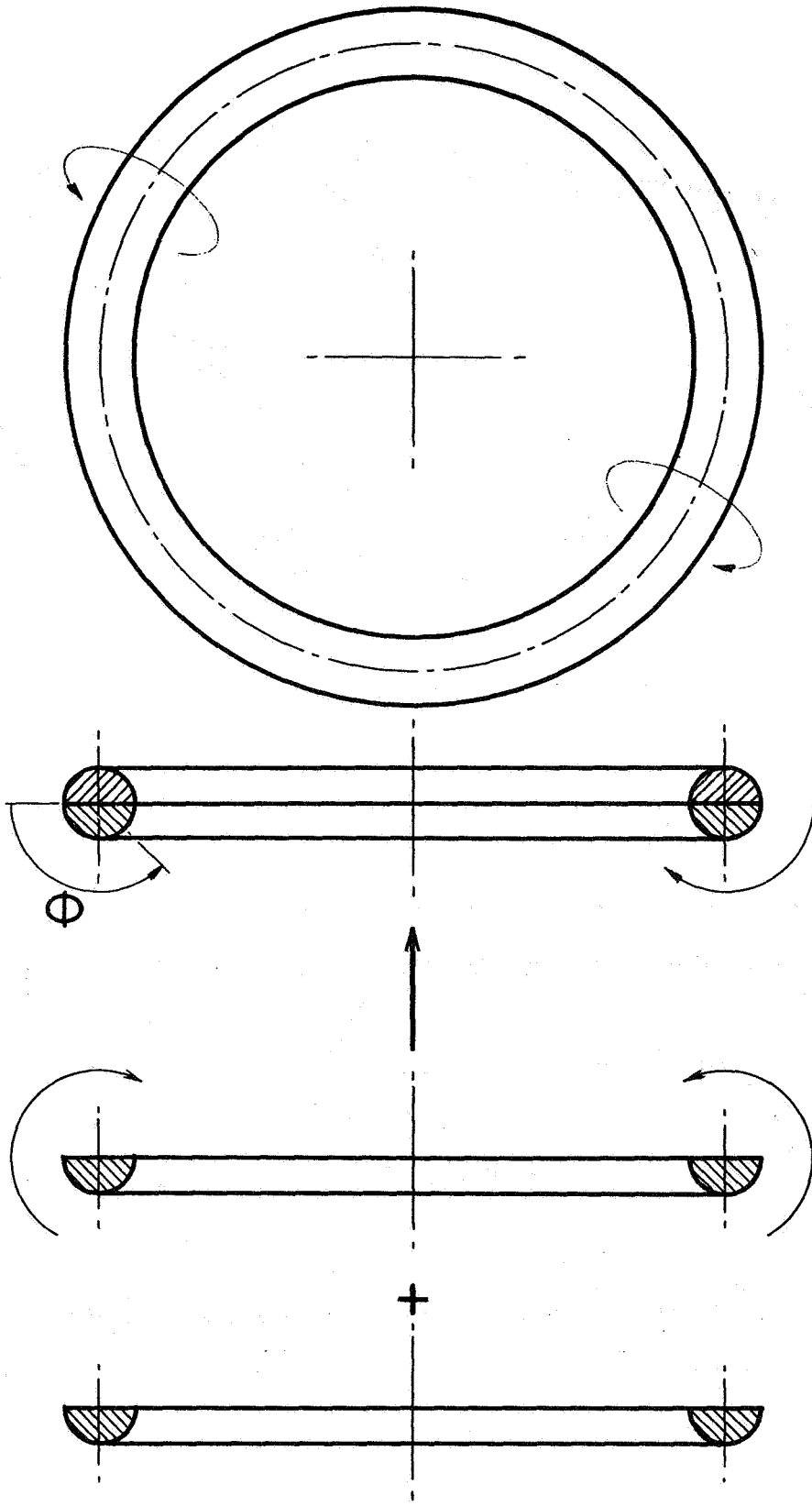

Figure 3.- Free invertible split ring.

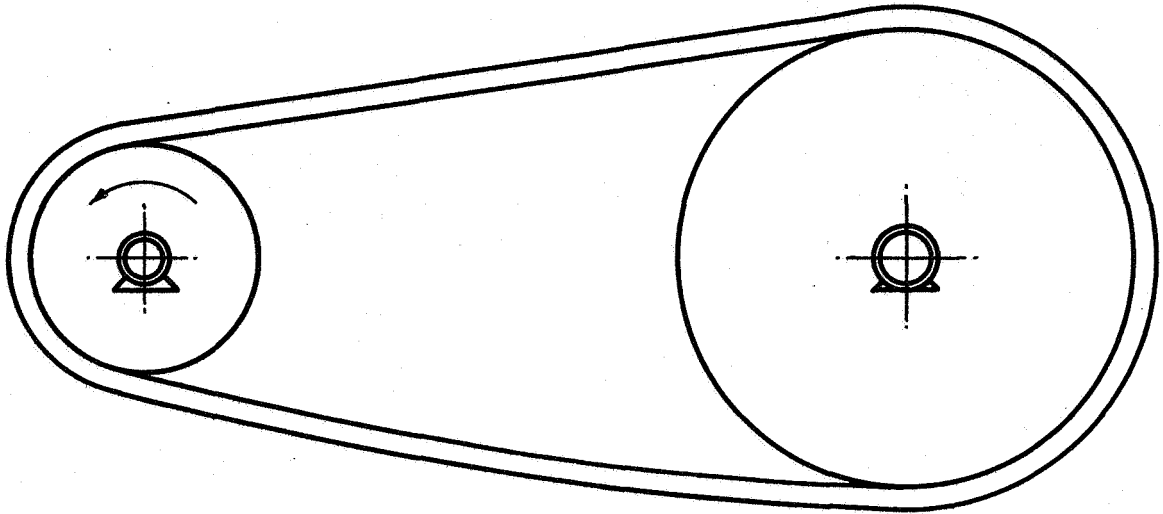

Figure 4.- Belt and pulleys.

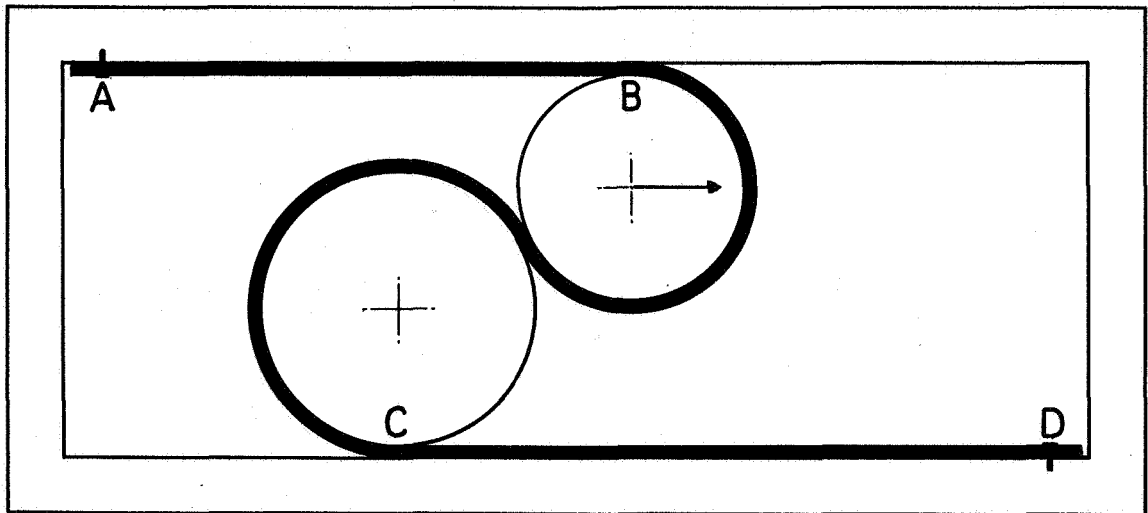

Figure 5.- Rolamite.