

CR 151166

SPACE BIOSYNTHESIS SYSTEMS

LASZLO K. NYIRI, PH.D.,

GIZELLA M. TOTH, PH.D.

FERMENTATION DESIGN, INC.

DIVISION OF NEW BRUNSWICK SCIENTIFIC CO., INC.

BETHLEHEM, PA 18017

Nas9-14961

REPORT NO.: 1021110176FD

November 1, 1976.

FINAL REPORT FOR PERIOD OF APRIL-OCTOBER, 1976.

PREPARED FOR

LYNDON B. JOHNSON SPACE CENTER

HOUSTON, TEXAS 77058

(NASA-CR-151166) SPACE BIOSYNTHESIS SYSTEMS
Final Report, Apr. - Oct. 1976 (Fermentation
Design, Inc.) 203 p HC A10/MF A01 CSCI 06M

G3/51

Unclass
13266

N77-16679

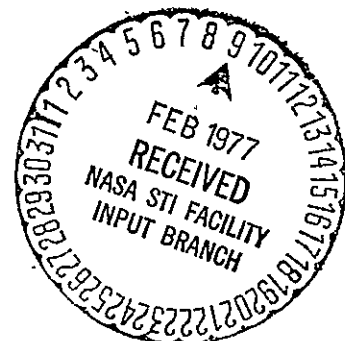

1. Report No.	2. Government Accession No.	3. Recipient's Catalog No.	
4. Title and Subtitle SPACE BIOSYNTHESIS SYSTEMS		5. Report Date November 1, 1976	6. Performing Organization Code N/A
		8. Performing Organization Report No. 102110176FD	10. Work Unit No. R & D
7. Author(s) Nyiri, L. K. and Toth, G. M.		11. Contract or Grant No. NAS9-14961	
		13. Type of Report and Period Covered Final Report, Apr.- Oct., 1976	
9. Performing Organization Name and Address Fermentation Design, Inc. 2014 City Line Road Bethlehem, Pa. 18015		14. Sponsoring Agency Code	
		12. Sponsoring Agency Name and Address Bioprocessing Laboratory DB4 NASA-Johnson Space Center Houston, TX 77058	
15. Supplementary Notes N/A			
16. Abstract This document contains the results of a study which analyses the technical and economic feasibility of production of organic compounds under microgravity conditions. It was found that certain peptide-protein type hormones of medical importance (HGH, HCG, ACTH, T ₄) may be candidates for space bioprocessing. The process includes biosynthesis and recovery-purification steps, all performed in an equipment which has the capability to operate automatically and can be scaled-up to commercial production size. So far qualitative type information is available on the growth and physiology of uni-cellular organisms exposed to microgravity. A prerequisite of the broad space bioprocessing program is to obtain quantitative information on the direct or indirect effects of microgravity on reactions performed in aqueous solutions. Model reactions based on chemical, enzymatic or cellular conversion of D-glucose into D-gluconic acid are designed to unequivocally define the advantages of microgravity on reaction mechanisms, mass-transfers and separation of organic chemicals and to serve as procedures to test the performance characteristics of space bioprocessing equipment.			
17. Key Words (Suggested by Author(s)) Bioprocessing, Space Bioreactor, Hormones, Process Kinetics in Microgravity, Animal Cell Cultures		18. Distribution Statement	
Security Classif. (of this report)	20. Security Classif. (of this page)	21. No. of Pages	22. Price*

*For sale by the National Technical Information Service, Springfield, Virginia 22161

PREFACE

TECHNICAL AND ECONOMIC FEASIBILITY OF SPACE BIOPROCESSING WAS STUDIED WITH THE FOLLOWING CONCLUSIONS:

1. CURRENTLY SPACE BIOPROCESSING IS LIMITED TO ELECTROPHORETIC SEPARATION OF CHARGED PARTICLES. THIS PRACTICE CAN BE BROADENED TO PRODUCE ORGANIC MOLECULES BY MEANS OF BIOSYNTHESIS AND RECOVER THEM WITH SEPARATION TECHNIQUES, INCLUDING ELECTROPHORESIS.

WITH THIS APPROACH, A COMPLETE MANUFACTURING SCHEME IS ACHIEVED WITH FULL CAPABILITY TO PRODUCE ORGANIC COMPOUNDS OF SOCIAL IMPORTANCE UNDER MICROGRAVITY CONDITIONS.

2. ACCORDING TO THE AVAILABLE EXPERIMENTAL DATA, SPACE ENVIRONMENT OFFERS ADVANTAGES OVER 1-G CONDITIONS IN HANDLING GASES AND LIQUIDS ESSENTIAL TO IMPROVE BOTH BIOSYNTHESIS AND RECOVERY TECHNIQUES.
 3. AS A PREREQUISITE TO IMPLEMENT SPACE BIOSYNTHESIS IT IS NECESSARY TO DETERMINE IN QUANTITATIVE TERMS THE DIRECT OR INDIRECT EFFECTS OF MICROGRAVITY ON CELLULAR AND SUBCELLULAR (ENZYMATIC) ACTIVITIES.
 4. MODEL REACTIONS WHICH QUANTITATIVELY DEFINE THESE EFFECTS INVOLVE THE ENZYMATIC OR MICROBIAL TRANSFORMATION OF GLUCOSE INTO GLUCONIC ACID. PROCESS MECHANISMS ARE KNOWN AND THE KINETICS CAN BE FOLLOWED BY DIRECT READING SENSORS.
 5. ORGANIC COMPOUNDS SELECTED AS PRIME CANDIDATES FOR SPACE BIOPROCESSING ARE THE PEPTIDE (PROTEIN) HORMONES. INCREASING SOCIAL NEED, HIGH COST OF PRODUCTION AND BROADENING FIELD OF APPLICATION WARRANTS THE SELECTION.
-

-
6. DESIGN AND OPERATION PRINCIPLES OF A COMPLETE BIO-PROCESSING EQUIPMENT IS OUTLINED IN THIS REPORT. THE EQUIPMENT CONSISTS OF: 1) BIOREACTOR, 2) RECOVERY AND 3) AUXILIARY SUBSYSTEMS. INSTRUMENTATION AND CONSTRUCTION OF BIOREACTOR MAKES IT POSSIBLE TO PERFORM MODEL REACTIONS AND CULTURE ANIMAL CELLS FOR THE PRODUCTION OF HORMONES. THE PRODUCT CAN BE RECOVERED-PURIFIED WITH THE RECOVERY SUBSYSTEM.
 7. A COMPREHENSIVE PROJECT TO INVESTIGATE EXPERIMENTALLY THE POSSIBILITIES OF SPACE BIOPROCESSING IS OUTLINED. THIS CONSISTS OF SYSTEMATIC STUDIES ON THE BIOSYNTHESIS AND RECOVERY-PURIFICATION OF PEPTIDE-PROTEIN TYPE HORMONES UNDER 1-G AND 0-G CONDITIONS. THE MULTI-DISCIPLINARY EFFORT UTILIZES THE SOUNDING ROCKET, SPACE SHUTTLE AND SPACELAB FLIGHTS. ESTIMATED DURATION OF THE PROJECT (STARTING IN 1977) IS 5+ YEARS.
 8. ANTICIPATED RESULTS INCLUDE:
 - 1) UNQUESTIONABLE DEFINITION OF EFFECT OF 0-G ON CELLULAR AND SUBCELLULAR ACTIVITIES,
 - 2) DEVELOPMENT OF NOVEL PEPTIDE-PROTEIN BIOSYNTHESIS AND RECOVERY TECHNIQUES,
 - 3) DEVELOPMENT OF SPACE BIOCHEMICAL ENGINEERING.
 9. ANTICIPATED SPINOFFS OF THE EXPERIMENTS INCLUDE:
 - 1) IMPROVED KNOWLEDGE ON CELL METABOLIC ACTIVITIES,
 - 2) ADAPTATION OF TECHNOLOGIES TO MANUFACTURE OTHER PEPTIDE-PROTEIN TYPE COMPOUNDS OF SOCIAL IMPORTANCE UNDER TERRESTRIAL AND/OR SPACE CONDITIONS,
-

-
- 3) ADAPTATION OF MEMBRANE SEPARATION TECHNOLOGIES TO ARTIFICIAL ORGAN APPLICATIONS,
 - 4) ADAPTATION OF DEVELOPED TECHNIQUES FOR TERRESTRIAL CHEMICAL OR BIOLOGICAL PROCESS CONTROL.
 - 5) APPLICATION OF KNOWLEDGE IN OTHER AREAS OF SPACE TECHNOLOGY (E.G. LIQUID WASTE TREATMENT IN SPACE COLONIES).
-

TABLE OF CONTENTS

1.	<u>INTRODUCTION</u>	1
2.	<u>OBJECTIVES</u>	4
3.	<u>LITERATURE REVIEW</u>	5
3.1.	<u>GENERAL COMMENTS</u>	5
3.2.	<u>PHYSICAL BEHAVIOR OF MATERIAL AS A FACTOR INFLUENCING BIOLOGICAL PROCESSES IN THE SPACE</u>	6
3.3.	<u>EFFECT OF SPACE ENVIRONMENT ON UNICELLULAR LIVING SYSTEMS</u>	7
3.3.1.	<u>EFFECT OF UV RADIATION AND SPACE VACUUM</u>	8
3.3.2.	<u>EFFECT OF HIGH ENERGY PARTICLES</u>	9
3.3.3.	<u>EFFECT OF WEIGHTLESSNESS</u>	10
3.4.	<u>EQUIPMENT DESIGN CONCEPTS AND ACCOMPLISHMENT</u>	11
3.5.	<u>BIOPROCESSING IN SPACE</u>	13
3.6.	<u>ASSESSMENT OF RESULTS</u>	14
4.	<u>MODEL REACTIONS FOR SPACE BIOPROCESSING EXPERIMENTS</u>	15
4.1.	<u>GENERAL CONSIDERATIONS</u>	15
4.2.	<u>MODEL REACTIONS FOR KINETIC STUDIES</u>	19
5.	<u>GLUCONIC ACID (GA) PRODUCTION</u>	21
5.1.	<u>CHEMICAL CHARACTERISTICS OF GA</u>	21
5.2.	<u>FORMATION OF GLUCONIC ACID</u>	24
5.2.1.	<u>EFFECT OF IONISING RADIATION ON D-GLUCOSE</u>	24
5.2.2.	<u>CHEMICALLY CATALYSED FORMATION OF D-GLUCONIC ACID</u>	28
5.2.3.	<u>ENZYMATIC CONVERSION OF D-GLUCOSE INTO GLUCONIC ACID</u>	32
5.2.4.	<u>MICROBIAL SYNTHESIS OF GLUCONIC ACID</u>	57
5.3.	<u>RECOVERY OF GLUCONIC ACID BY ELECTROPHORESIS</u>	67
5.3.1.	<u>IONOPHORESIS OF GLUCONIC ACID</u>	67

6.	<u>BIOPROCESSING OF HORMONES</u>	69
6.1.	<u>GENERAL COMMENTS</u>	69
6.2.	<u>IN VITRO CULTURING OF ANIMAL CELLS</u>	73
6.2.1.	<u>GROWTH CHARACTERISTICS OF ANIMAL CELLS</u>	74
6.2.2.	<u>EQUIPMENT FOR CULTURING ANIMAL CELLS IN VITRO</u>	78
6.3.	<u>PRODUCTION OF HORMONES BY ANIMAL CELLS</u>	85
6.3.1.	<u>GROWTH HORMONE PRODUCTION IN VITRO</u>	88
6.3.2.	<u>HUMAN CHORIONIC GONADOTROPIN HORMONE (HCG) PRODUCTION IN VITRO</u>	90
6.4.	<u>RECOVERY OF HORMONES</u>	93
6.5.	<u>HORMONES AS CANDIDATES FOR SPACE BIOPROCESSING</u>	102
6.5.1.	<u>OVERVIEW OF THE POSSIBILITIES</u>	102
6.5.2.	<u>SELECTION OF HORMONES FOR SPACE BIOPROCESSING</u>	104
7.	<u>EQUIPMENT DESIGN FOR SPACE BIOPROCESSING</u>	119
7.1.	<u>GENERAL OBSERVATIONS</u>	119
7.2.	<u>OUTLINE OF EXPERIMENTS</u>	124
7.3.	<u>BASIC BIOREACTOR DESIGN</u>	128
7.3.1.	<u>GENERAL</u>	128
7.3.2.	<u>RATIONALE OF THE BIOREACTOR DESIGN</u>	129
7.3.3.	<u>ELEMENTS OF BASIC BIOREACTOR SYSTEM</u>	132
7.3.4.	<u>PROCESS STATUS ANALYSIS AND LOGGING SUBSYSTEMS</u>	140
7.3.5.	<u>INTEGRATION OF SB-1 WITH RECOVERY APPARATUS</u>	144
7.3.6.	<u>COORDINATED OPERATION OF SUBSYSTEMS</u>	146
7.3.7.	<u>SPECIFICATIONS</u>	148
7.4.	<u>EXAMPLE OF EXPERIMENTING THE EFFECT OF MICROGRAVITY ON BIOCHEMICAL PROCESSES</u>	152
7.4.1.	<u>MODEL EXPERIMENT</u>	152
7.4.2.	<u>DESCRIPTION OF THE EXPERIMENT</u>	152
8.	<u>CONCLUSIONS AND RECOMMENDATIONS</u>	156
8.1.	<u>CONCLUSIONS</u>	156
8.1.1.	<u>BIOPROCESSING IN SPACE</u>	156
8.1.2.	<u>PROBLEMS OF BIOPROCESSING UNDER TERRESTRIAL CONDITIONS</u>	158
8.1.3.	<u>EFFECT OF MICROGRAVITY CONDITIONS ON BIO- LOGICAL ACTIVITIES AND MATERIAL HANDLING</u>	159

8.1.4.	<u>DETERMINATION OF EFFECT OF SPACE CONDITIONS</u> <u>ON BIOLOGICAL MECHANISMS</u>	161
8.1.5.	<u>PRODUCTION OF ORGANIC COMPOUNDS IN THE SPACE</u>	163
8.1.6.	<u>BIOPROCESSING EQUIPMENT</u>	166
8.1.7.	<u>PROJECT IMPLEMENTATION</u>	167
8.1.8.	<u>POTENTIAL SPINOFFS</u>	169
8.1.9.	<u>SUMMARY OF CONCLUSIONS</u>	169
8.2.	<u>RECOMMENDATIONS</u>	171
8.2.1.	<u>PROJECT OBJECTIVES</u>	171
8.2.2.	<u>PROJECT IMPLEMENTATION</u>	171
8.2.3.	<u>PROJECT PROMOTION</u>	174

LIST OF ILLUSTRATIONS

<u>FIGURE 1</u>	<u>SCHEME OF D-GLUCOSE DECOMPOSITION DURING IRRADIATION</u>	25
<u>FIGURE 2</u>	<u>CHEMICAL ROUTES IN D-GLUCONIC ACID PRODUCTION</u>	29
<u>FIGURE 3</u>	<u>INTEGRATED PATHWAYS OF ENZYMATIC SYNTHESIS OF D-GLUCONIC ACID</u>	35
<u>FIGURE 4</u>	(A) <u>STRUCTURE OF FAD</u> ; (B) <u>STRUCTURE OF GLUCOSE OXIDASE</u>	37
<u>FIGURE 5</u>	<u>SPECTRAL CHANGES DURING GLUCOSE OXIDASE REDUCTIVE HALF REACTION</u>	43
<u>FIGURE 6</u>	<u>COMPARISON OF DATA ON GLUCOSE OXIDASE KINETICS OBTAINED WITH SPECTROPHOTOMETRIC AND OXYGEN PROBE TECHNIQUES</u>	43
<u>FIGURE 7</u>	<u>ASSUMED KINETIC MECHANISMS FOR FLAVO-PROTEIN OXIDASES</u>	54
<u>FIGURE 8</u>	<u>PATHWAY OF D-GLUCONIC ACID BIOSYNTHESIS IN MICROBIAL CULTURES</u>	62
<u>FIGURE 9</u>	<u>TIME COURSE OF A D-GLUCONIC ACID FERMENTATION</u>	65
<u>FIGURE 10</u>	<u>DEPENDENCY OF PRODUCT (P) FORMATION RATE ON THE INTERMEDIER (L) CONCENTRATION</u>	65
<u>FIGURE 11</u>	<u>COMPARISON BETWEEN ENVIRONMENTAL CONDITIONS FOR CULTURING MICROBIAL AND ANIMAL CELLS IN VITRO</u>	76
<u>FIGURE 12</u>	<u>APPARATUS AND TECHNIQUES FOR CULTURING ANIMAL CELLS</u>	79

LIST OF ILLUSTRATIONS
(CONTINUED)

<u>FIGURE 13</u>	<u>BASIC EQUIPMENT FOR CULTURING ANIMAL CELLS IN VITRO</u>	79a
<u>FIGURE 14</u>	<u>DESIGN CONCEPT AND OPERATION OF MICROCAPILLARY ANIMAL CELL CULTURE</u>	80
<u>FIGURE 15</u>	<u>DESIGN CONCEPT OF A SPINNER CULTURE</u>	82
<u>FIGURE 16</u>	<u>DESIGN CONCEPT OF A STIRRED CELL SUSPENSION CULTURE</u>	82
<u>FIGURE 17</u>	<u>EFFECT OF HYDROCORTISONE (HC) ON PROLACTIN AND GH PRODUCTION RATES BY GH3 CELLS</u>	89
<u>FIGURE 18</u>	<u>EFFECT OF 17 β-ESTRADIOL ON PROLACTIN AND GH PRODUCTION BY GH3 CELLS</u>	89
<u>FIGURE 19</u>	<u>PRODUCTION OF HCG HORMONE WITH CHORIOCARCINOMA JEG-7 CELLS GROWN IN A CAPILLARY PERFUSION APPARATUS</u>	92
<u>FIGURE 20</u>	<u>SCHEMES OF HORMONE MANUFACTURING</u>	94
<u>FIGURE 21</u>	<u>STRUCTURE AND CHEMICAL CHARACTERISTICS OF HGH</u>	107
<u>FIGURE 22</u>	<u>INTERACTIONS OF HORMONAL EFFECTS RELATIVE TO HGH</u>	109
<u>FIGURE 23</u>	<u>INTERACTIONS OF HORMONAL EFFECTS RELATIVE TO HCG (LH)</u>	111
<u>FIGURE 24</u>	<u>STRUCTURE OF ACTH</u>	113
<u>FIGURE 25</u>	<u>INTERACTIONS RELATIVE TO ACTH</u>	113

LIST OF ILLUSTRATIONS
(CONTINUED)

<u>FIGURE 26</u>	<u>INTERACTIONS OF T₄ HORMONAL EFFECTS</u>	116
<u>FIGURE 27</u>	<u>OUTLINE OF EXPERIMENTS IN 1-G AND 0-G CONDITIONS</u>	125
<u>FIGURE 28</u>	<u>CONCEPTUAL DESIGN OF SPACE BIOREACTOR</u>	130
<u>FIGURE 29</u>	<u>PRINCIPLE OF PRESSURE CONTROL</u>	136
<u>FIGURE 30</u>	<u>QUICKFIT CONNECTIONS OF SYSTEM ELEMENTS</u>	137
<u>FIGURE 31</u>	<u>ATTACHMENT OF SENSORS TO THE RE-ACTION CHAMBER</u>	139
<u>FIGURE 32</u>	<u>SCHEMATICS OF HARDWARE CONFIGURATION FOR 0-G AND GROUND BASED EXPERIMENTS</u>	141
<u>FIGURE 33</u>	<u>INTEGRATION OF SB-1 WITH RECOVERY APPARATUS</u>	145
<u>FIGURE 34</u>	<u>CONCEPT OF SYSTEMS OPERATION CONTROL</u>	147

LIST OF TABLES

<u>TABLE I.</u>	<u>ANALYSIS OF PROCESSES FOR SPACE BIOTECHNOLOGY</u>	17
<u>TABLE II.</u>	<u>EXAMPLES OF MODEL BIOLOGICAL REACTIONS</u>	22
<u>TABLE III.</u>	<u>PRODUCTS ORIGINATED FROM D-GLUCOSE AFTER γ-IRRADIATION</u>	26
<u>TABLE IV.</u>	<u>LIST OF MICROORGANISMS WITH CAPABILITY TO PRODUCE D-GLUCONIC ACID FROM D-GLUCOSE</u>	58
<u>TABLE V.</u>	<u>CHARACTERISTICS OF MICROBIOLOGICAL PRODUCTION OF D-GLUCONIC ACID</u>	61
<u>TABLE VI.</u>	<u>COMPOSITION OF MEDIA USED FOR GLUCONIC ACID PRODUCER MICROBIAL CELL CULTIVATION</u>	64
<u>TABLE VII.</u>	<u>EXPERIMENTAL CONDITIONS FOR D-GLUCONIC ACID IONOPHORESIS</u>	68
<u>TABLE VIII.</u>	<u>SOME IMPORTANT HORMONES OBTAINED FROM VERTEBRATES</u>	71
<u>TABLE IX.</u>	<u>COMPARISON OF MAIN BIOLOGICAL CHARACTERISTICS OF MICROBIAL AND ANIMAL CELLS</u>	75
<u>TABLE X.</u>	<u>COMPARISON OF ANIMAL CELL YIELDS OBTAINED WITH DIFFERENT CELL CULTURE TECHNIQUES</u>	84
<u>TABLE XI.</u>	<u>LIST OF HORMONES PRODUCED BY MAMMALIAN CELL CULTURES</u>	86
<u>TABLE XII.</u>	<u>SOURCE AND COMMERCIAL AVAILABILITY OF SOME HORMONES OF MEDICAL IMPORTANCE</u>	95

LIST OF TABLES
(CONTINUED)

<u>TABLE XIII.</u>	<u>GH EXTRACTION-PURIFICATION</u>	97
<u>TABLE XIV.</u>	<u>HCG EXTRACTION-PURIFICATION</u>	98
<u>TABLE XV.</u>	<u>ACTH EXTRACTION-PURIFICATION</u>	99
<u>TABLE XVI.</u>	<u>I4 EXTRACTION-PURIFICATION</u>	100
<u>TABLE XVII.</u>	<u>COMPARATIVE PRODUCTION DATA ON VARIOUS PHARMACEUTICALS (U.S. PRODUCTION)</u>	103
<u>TABLE XVIII.</u>	<u>CONTROL SYSTEMS GENERALLY USED IN BIOCHEMICAL ENGINEERING</u>	123
<u>TABLE XIX.</u>	<u>SPECIFICATIONS OF THE INSTRUMENTATION SYSTEM ELEMENTS</u>	134
<u>TABLE XX.</u>	<u>PRELIMINARY SPECIFICATIONS FOR SPACE BIOPROCESSING SYSTEM</u>	149

LIST OF ABBREVIATIONS

ACTH	ADRENOCORTICOTROPIC HORMONE, ADRENOCORTICOTROPIN, CORTICOTROPIC HORMONE
BGH	BOVINE GROWTH HORMONE
CAMP	CYCLIC ADENOSINE MONOPHOSPHATE
CCFS	COMPUTER COUPLED FERMENTATION SYSTEM
DAN	DATA ANALYSIS COMPUTER PROGRAM, REAL TIME
DO	DISSOLVED OXYGEN CONCENTRATION IN PERCENT OF SATURATION
EFO	ELECTROPHORESIS
FAD	FLAVINE ADENINE DINUCLEOTIDE
FADH ₂	FLAVINE ADENINE DINUCLEOTIDE, REDUCED
GH	GROWTH HORMONE, SOMATOTROPIN, STH, (ANTERIOR) PITUITARY GROWTH HORMONE, ADENOHYPOPHYSEAL GROWTH HORMONE, SOMATOTROPHIC HORMONE
HGH	HUMAN GROWTH HORMONE
HCG	HUMAN CHORIONIC GONADOTROPIN
HZE	HIGH ENERGY PARTICLES
K _L ^a	VOLUMETRIC OXYGEN TRANSFER COEFFICIENT, HR ⁻¹
LH	LUTEINISING HORMONE, LUTEOTROPIN, ICSH, INTERSTITIAL CELL STIMULATING HORMONE, GONADOTROPIN II, CORPUS LUTEUM - RIPENING HORMONE
m-RNA	MESSANGER RIBONUCLEIC ACID

MSH	MELANOCYTE STIMULATING HORMONE, MELANOPHORE HORMONE, MELANOTROPHIN, PIGMENTATION HORMONE
MW	MOLECULAR WEIGHT, G
NAD	NICOTINEAMIDE - ADENINE - DINUCLEOTIDE
NADH ₂	NICOTINEAMIDE - ADENINE - DINUCLEOTIDE, REDUCED
ORH	OXIDATIVE HALF-REACTION
PVA	POLIVYNILACETATE
p _O ₂	PARTIAL PRESSURE OF OXYGEN IN GAS PHASE, ATM
RGH	RAT GROWTH HORMONE
RHR	REDUCTIVE HALF-REACTION
RNA	RIBONUCLEIC ACID
RQ	RESPIRATORY QUOTIENT, DIMENSIONLESS
S	SUBSTRATE
SCP	SINGLE CELL PROTEIN
SS	STAINLESS STEEL
T	TEMPERATURE, C ^o ; METRIC TON
T ₃	3, 5, 3' - TRIIODOTHYRONINE
T ₄	THYROXINE, 3, 5, 3', 5' - TETRAIODOTHYRONINE
tRNA	TRANSFER RIBONUCLEIC ACID
TSH	THYROID STIMULATING HORMONE, THYROTROPIC HORMONE, TTH, THYROTROPIN

1. INTRODUCTION

In the past years there was an increasing interest observable toward the biological aspects of the space environment. So far, however, experiments related to the life sciences were geared - because of obvious reasons - toward human physiology and medicine.

The Colloquium on Bioprocessing in Space held at NASA's Lyndon B. Johnson Space Center (Houston, TX) reached an understanding on the importance of cellular and subcellular systems oriented research in space.

Experiments related to cell biology (including propagation of embryo cells, fungi, bacteria, bacteriophage, viruses) resulted in predominantly qualitative information relative to the effect of space environment on cellular functions. However, various experimental data with respect to behaviour of microorganisms exposed to space environment indicate that this unique condition may offer advantages in propagation of cells and biosynthesis of organic compounds. In addition, the advantages of zero-gravity on separation of biological materials using electrophoresis (EFO) was demonstrated (1,2). This subject was already discussed from a broader point of view by BREDT and MONTGOMERY in 1975 (3).

Since electrophoresis has been widely used in process biochemistry for long periods of time (4,5), its successful application in space has opened up the possibility to utilize both the enhanced metabolic capability of living cells and the improved separation technique to produce organic compounds of scientific and medical importance in space.

Based on early successes with space electrophoresis the term: space bioprocessing is currently used for a process whereby charged particles are separated by means of a physico-chemical technique.

From the viewpoint of terrestrial biochemical engineering bioprocessing means the production of organic compounds via biosynthesis in a bioreactor (using intact cells or their subcellular elements, e.g. enzymes for this purpose) and separating them from the reaction mixture by means of physico-chemical techniques.

Using electrophoresis only to separate biological materials in space, the following technological schedule can be accomplished:

1. Material is processed on Earth with conventional techniques,
2. Material shuttled into microgravity environment where it is separated, purified, etc.,
3. Material is returned to Earth for further processing with conventional techniques,
4. Utilization of the material on Earth.

If a biochemical reactor is designed with a capability to support cellular and subcellular activities under zero-gravity conditions and this reactor is connected to an EFO apparatus the result is a complete bioprocessing equipment which performs both biosynthesis and recovery functions in the microgravity environment.

Operating such equipment, the former technical scheme is broadened incorporating the first three steps in one functional entity (system). Only the raw material supply and the return of the finished product are subjects of shuttle transportation. This scheme has definite advantages from the viewpoint of logistics and ease of operation. A careful analysis is needed, however, to define the technical advantages and the potential social effects a space bioprocessing technology may create if it is implemented.

Supported by a grant (NAS9-14961), Fermentation Design, Inc. performed a study on this subject. The seven-month search resulted in the compilation of the available information relative to the following areas:

1. Which biological processes can be used as models to define quantitatively the effect of space environment on metabolic activities of cells and enzymes,
2. What is the organic compound of choice, bio-processing of which is economically attractive if the model experiments demonstrate enhanced metabolic activities in the space environment,
3. What kind of equipment is necessary to carry out biosynthesis oriented research and development in the space and perform control experiments on the earth, and finally:
4. What problems in industrial cell culture systems are gravity related and what potential solutions can be offered by culturing cells in microgravity environment.

Additional scope of the survey was the compilation of available technical and scientific information. This serves as the basis to design experiments to:

1. Check the performance capability of the bioprocessing system designed and built for cell cultures, product biosynthesis and recovery, and
2. Test the effectiveness of the selected technology which will be developed during the project implementation.

The survey revealed that:

1. There is a possibility to test the effect of microgravity on cellular and subcellular activities,
-

-
2. Viewing the tendency of the microbiology based industries it is possible to find economically significant organic compounds which may be candidates for bioprocessing in microgravity, and
 3. It is possible to design an apparatus which can be considered as a prototype of a "bioprocessor" which can be used both for test purposes and initial studies of bioprocess organic compounds of significance in the space.

Conclusion and recommendation part of the survey compiles these key points and serves as an executive summary. Therefore, scientific studies can be bypassed if the reader is not interested in technical details.

It is hoped that the information compiled in this Final Report will give an impetus to the effort NASA is currently making to exploit the advantages of space environment in processing biological materials using novel technologies in the field of biochemistry, cell cultures and separation processes.

2. OBJECTIVES

In view of the developments in biochemical engineering, applied biochemistry and considering the trends in the pharmaceutical industry, the objectives of this study were:

1. Finding a reaction mechanism by which quantitative studies can be performed, unequivocally demonstrating the effect of space environment on organic chemical, enzymatic and cellular reactions. This mechanism can also serve later as a quality control procedure to check the performance characteristics of equipment designed for the project implementation;
-

-
2. Finding a product line of social significance which can be a candidate for industrial scale bioprocessing in microgravity environment;
 3. Outline the design principles of an apparatus by which test experiments can be performed both to check quantitatively the advantages of microgravity conditions on cellular activities and enzymatic reactions, industrial bioengineering, and perform studies on the production characteristics of the organic compound(s) found suitable for bioprocessing in space;
 4. What necessary steps are required to implement the project as well as the minimum success criteria for each step.

Methodology of the survey included collection of scientific-technical data in order to support our position, draw conclusions and make recommendations in the subject matter.

3. LITERATURE REVIEW

3.1. GENERAL COMMENTS

This part of the study is considered essential to conclude the prior art as well as to define relevancy of biological experiments performed in a space environment. The search of the literature revealed that 1) papers, documents written on the subject are not readily accessible, most of them being internal reports of companies, research institutions or their consultants as well as being contract reports, 2) because of the lack of experimental information, most of the essays are speculative, 3) conditions of the experiments are generally inadequate in view of the complexity of living systems and 4) there is an "identity problem" resulting in confusion of terminologies calling the

discipline involved "space bioprocessing", "space microbiology", "space biotechnology", etc. All of these described features are generally characteristic to newly evolving disciplines. It is desirable, therefore, to try to find common denominators, define terminologies and make them widely accessible to the industrial and scientific community in the near future.

Review of the available literature made it possible to categorize the documents into two broad classes, namely:

- (1) Description of effect of space environment on microbial systems.
- (2) Concepts and accomplishments in equipment design and operation.

Of course, in many cases the two classes appear in the same literature. At this stage of the work, however, it seems necessary to evaluate the two classes separately.

3.2. PHYSICAL BEHAVIOUR OF MATERIAL AS A FACTOR INFLUENCING BIOLOGICAL PROCESSES IN THE SPACE

The survey revealed a series of problem areas all of them of importance from technical and logistics points of view. Biosynthesis processes are performed in aqueous systems and are controlled predominantly by mass transfer conditions (6). This is emphasized in the case of transfer of gaseous materials into and out of the liquid. In particular, because of its low solubility, the transfer of oxygen into the liquid is rated among the key problem areas.

In addition, the removal of "metabolic heat" is considered as an other technical problem in unit

operations. Under 1-G conditions these problems are technically solved (although not to complete satisfaction) by application of mixing elements and aerators to the bioreactors.

During the review of literature related to the physical behaviour of liquids in Space, unusual characteristics were revealed - lack of convection, buoyancy (3). This is of extreme importance with respect to mixing of three phases (gas, liquid, solids (cells)) in order to accomplish the mass and heat transfer conditions necessary to carry out biosynthetic activity on cellular and/or subcellular level. There are no literature data available on the effect of liquid physico-chemistry upon metabolism, which necessitates intensive study in this field.

The second area of importance is the statistical accuracy of the presently available data on the behaviour of cellular and subcellular systems exposed to space environment conditions. Data available were primarily of a qualitative nature. Therefore, it is absolutely necessary to obtain data of high statistical accuracy in order to define the effect of space environment on metabolic activities. This requires kinetic studies not only on cellular and subcellular level but, if it is possible, on the level of organic-chemical synthesis. This latter area of activity is considered essential to define the influence of unusual fluid behaviour on reaction kinetics with the interaction of cellular-subcellular elements.

Third, since all of the experiments will ultimately be conducted in a habitat (Spacelab) where the workload is high, the maximum possible level of automation is to be considered for 1) to follow the process and 2) coordinate the function of individual system elements. The prototype's operation may result in technical information essential to construct fully automated bioprocessing systems in the Space.

Fourth, substantial amount of experimental work is needed on the Earth before attempts to perform biosynthesis in Space can take place. The work must be geared to develop equipment and test procedures for a biosynthesis system in order to compare the results obtained on Earth and in Space.

3.3. EFFECT OF SPACE ENVIRONMENT ON UNICELLULAR LIVING SYSTEMS

Space environment has four unique factors influential on living systems: 1) ultralow temperature, 2) high vacuum, 3) high energy particle (radiation) effects, and 4) weightlessness (or low gravitational acceleration). Considering these effects, factors 1) and 2) will possibly be excluded from the future biosynthesis systems by proper design whereas factors 3) and 4) are anticipated to be utilized in the cellular genetics and physiology. In particular, factor 4) (O-G condition) is considered to be the most important, reportedly influencing cellular metabolic activities. Also, factors 1)-3) can be reproduced on the Earth. On the other hand, zero-gravity, consequently zero-gravity based technology does not exist under terrestrial conditions. It is anticipated, therefore, that the bioprocessing technology development will mainly be based on utilization of weightlessness as key environmental factor.

So far, the most concise review on the behaviour of micro-organisms in Space was given by TAYLOR (7). Based on his and other authors' reports, the following analysis can be made on the effect of various space environmental factors on unicellular living systems.

3.3.1. EFFECT OF UV RADIATION AND SPACE VACUUM.

Although solar ultraviolet irradiation in the wave-

length between 200 and 300 nm inactivated T-1 coliphage, P. roqueforti and Tobacco Mosaic Virus (LORENZ et al, (8)), effects below 200 nm and above 300 nm (up to 5,000 nm) were not significant. This finding is similar to those observed on Earth with UV lights.

Other data obtained with ten microbial strains exposed to both solar UV and space vacuum indicate that the space vacuum may enhance the susceptibility of spores to UV rays (at 254 nm) (7). On the other hand, B. subtilis strain 168 spores survived space vacuum (and low temperature although this latter condition is not mentioned as the objective of the experiment when they were shielded against the UV rays.

Solar UV rays on Aeromonas proteolytica, Rhodotorula rubra, S. cerevisiae, Trychophyton terrestre, Chaetomium globosum (Apollo 16) did not alter significantly the survival rate or endopeptidase production by (A. proteolytica) (7).

3.3.2. EFFECT OF HIGH ENERGY PARTICLES

The subject was investigated as part of an analysis of the mutagenic effect of heavy irradiation on microbial cells. Probably the best planned experiment was performed by BUCHNER and his coworkers (9, 10), followed by an evaluation made by HORNECK et al (11). B. subtilis strain 168 spores were imbedded in thin sheets of PVA layers containing dosimeters for measuring the passage of high-energy, multi-charged (HZE) particles. Comparing the experimental data with controls performed on the Earth it appears that HZE particles had no effect on subsequent germination and outgrow of spores. Although genetic evaluation was not made, the experiment, at least, indicated that spores which were hit by HZE particles in space retained their ability to germinate.

ZHUKOV-VEREZHNİKOV and his coworkers utilized E. coli K-12 (A) phage to test the amount of γ -radiation as well as the protons and rapid neutrons (12). Experimental system exposed for 2-25 hours to space conditions resulted in increased phage production (compared to Earth control conditions) and the phage production increased (although not proportionally) with the duration of the flight.

Control experiments also indicated that vibration during launch followed by γ -radiation may create this phenomenon. On the other hand, MATTONI (13) as well as MATTONI and coworkers reported (14) experiments with S. typhimurium where the phage production decreased (as a result of increased resistance of S. typhimurium against γ -radiation). Later, ZHUKOV-VEREZHNİKOV and his coworkers also reported decrease in phage production by E. coli (15).

Experimental results with Neurospora crassa (Conidia) during the Gemini XI and Biosatellite II flights indicate that neither the survival nor the mutation frequency of the conidia deposited on surfaces were altered during 71 hours orbital flight (14). Conidia suspended in agar expressed high levels of survival and lower frequency of mutation induction. On this basis, SERRES et al concluded that the spaceflight affected a protective influence (16). Experimental data were, however, biased because of the uncontrolled high temperature inside the spacecraft.

3.3.3. EFFECT OF WEIGHTLESSNESS

One of the objectives of the Biosatellite II project was to evaluate the effect of weightlessness on 1) bacterial growth, 2) free bacteriophage density, 3) phage induction and production rate and 4) bacterial ultrastructure.

The most significant observation was that S. typhimurium cell density was significantly higher than the one obtained in the ground control experiments (13). No other measured variables differed significantly from the control state: MATTONI's interpretation of the increased cell density is centered around the random cell distribution in the culture liquid under reduced gravity conditions. Such a distribution would increase the efficiency of nutrient transfer into and waste transport from the cells. JORDAN's interpretation of the phenomenon (17) calls for the unknown physico-chemical (lack of buoyancy) and environmental factors influencing sedimentation of bacteria, liquid mixing (hence O₂ supply) as well as foaming. Behaviour of fluids under weightlessness (18) seems to corroborate this concept. Also MATTONI mentions (13) that in unicellular systems the direct effect of weightlessness on intracellular mechanisms is less probable than the indirect ones (through the unusual fluid-gas mixing conditions). As CUTAIA concludes, "the observation is a result of many factors ... and leaves the question of the specific impact of weightlessness unanswered." (19).

3.4. EQUIPMENT DESIGN CONCEPTS AND ACCOMPLISHMENTS

Above mentioned in-flight experiments were carried out in test tubes, on agar plates, or on membrane surfaces. The equipment used for these projects did not leave provision to measure and/or control environmental conditions (e.g. temperature) or to follow the growth patterns.

The first known experimental apparatus which had the provision to insulate the growth chamber from the rest of the orbital vehicle is reported by WARD and his coworkers (20). The equipment was used to test the physiological behaviour of multicellular algae

(Chlorella sorokiniana), and duckweed (Spirodella polyrhiza) during the orbital flight of a non-recoverable orbital vehicle (OVI) sponsored by the Air Force Office Of Aerospace Research (AFOAR).

The apparatus contained a growth chamber with airvents, temperature and pressure control, O₂ and CO₂ sensors, illumination and light sensitivity measuring apparatus to assure 12 hours of light-dark periods for the photosynthetic organisms. The equipment was sterilizable. Sensed variables were collected on magnetic tapes and sent back to the Earth by telemetry when the satellite was over a tracking station.

The reports prepared by the experimenters revealed that 1) despite the complexity of the system sterile culture was obtained using heat, ethylene oxide-CO₂ sterilization of the apparatus as well as UV illumination during the transfer of the cultures, 2) temperature control within 27.4 to 28.1° C was achieved ($\pm 0.35^\circ$ C), 3) pressure increased from 751.1 to 764.5 mmGh in 228 hours ($dP/dt = +0.057$ mmGh/hr), 4) illumination control system worked satisfactorily, 5) signal transmission was 87.5 percent effective (three out of 24 data points were lost), 6) one of the two apparatus developed leak and lost pressure following the launch resulting in a complete loss of the Ch. sorokiniana experiment.

Further analysis of the experimental setup revealed that besides the proper function of the apparatus, there were two sensitive areas of the test, namely: 1) preflight maintenance of environmental conditions for growth (the cultures stayed in launch position for 255 hours) and 2) physical stresses due to the launch. In the case of the slow-growing duckweed, the first problem is not serious compared to the conditions existing in the case of a fast-growing microbe.

The experiment was performed on a 547.03-478.73 nautical miles orbit and the gravitational force was 1.1×10^{-5} g on the cultures. The RQ value (light period RQ) was 1.0 at flight versus 0.9 on ground control, the RQ (dark RQ) was 0.9 during flight versus 1.3 on ground which was considered insignificant by the experimenters (22). Based on our experiments with CCFS which measured RQ by DAN program (21) such difference may originate from instrument inaccuracies.

Another apparatus for production of vaccines in zero-gravity is proposed by JORDAN of Martin Marietta Co. (17). Equipment (designated as "zero-g-fermentor") is based in fact, on a dialysis fermentor designed by SCHULTZ and GERHART (22) where the culture is circulated through a dialysis membrane in order to assure fluid mixing (hence O₂ transfer) as well as to remove undesired products of inhibitory nature (e.g. CO₂). It is not known, however, whether a prototype was built and experimentally tried. Therefore, the equipment performance to establish and maintain proper environmental conditions (T, P, pH, DO, substrates' concentration and proportion) cannot be evaluated. Nevertheless, the concept may serve as the starting point to design bioreactors for extended study of the effect of space environment on microbial cell physiology and metabolic activity. It is noted that MMC has a patent pending "Apparatus and Method for Microbial Fermentation in Zero-Gravity Environment" (Serial 143808, May 17, 1971).

3.5. BIOPROCESSING IN SPACE

Parallel with the biology-oriented experiments, NASA performed extensive studies on material processing in space. A concise study appeared on the results (3) as well as a Colloquium was held at NASA's Johnson Space Center in March, 1976. Information indicates that electrophoresis (EFO), a widely used technique for separation of organic compounds in biochemistry

and biotechnology, can be useful tool in space bioprocessing because it gives finer resolution and separation of charged particles (including living animal cells) than EFO performed under 1-G conditions.

These results necessarily lead to the development of a bioprocessing system (23) which incorporates both the biosynthesis and recovery techniques and apparatus. The complexity of such an operation requires high level instrumentation for analysis of process status and process control as well as the coordinated function of the auxiliary equipment. This integrated system concept is considered as an advanced form of equipment and technology for automatic and complete bioprocessing operations in space.

3.6. ASSESSMENT OF RESULTS

Although the reported results are in many cases contradictory (by virtue of the difficulty to separate the antagonistic and/or synergistic effects of various space environmental factors on cellular physiology) data indicate that:

1. Spaceflight environment can be selective creating cellular behaviour different from the ones found on Earth.
 2. It is necessary to design a test method comprising a series of experiments which ultimately prove or disprove this selectivity both from qualitative and quantitative points of view.
 3. The test method must be concise enough to cover activities on extracellular, cellular, and sub-cellular level.
 4. The experiments must be conducted in well-controlled environment to rule out the interactive effects of various environmental factors, and finally,
-

-
5. An integrated system must be designed to implement bioprocessing in the Space.

In conclusion, it became evident that two parallel operations have to be considered, namely:

1. Development of a test method to achieve unequivocal answers on the effect of space conditions (weightlessness in particular) on extracellular, cellular, subcellular kinetics (initial stage of operation), and
2. Definition of a compound, bioprocessing of which in Space has scientific, economic and/or social importance.

The equipment to be designed for this purpose must have specifications which make it possible to apply it to both types of operation.

4. MODEL REACTIONS FOR SPACE BIOPROCESSING EXPERIMENTS

4.1. GENERAL CONSIDERATIONS

A major objective for the initial stage of the Bioprocessing Program is the demonstration of technical feasibility of space biosynthesis and biochemical separation techniques. Implementation of biosyntheses and recovery-purification processes in Space, however, faces constraints from the viewpoint of payload, in particular regarding the requirement of a relatively large quantity of water during each step of the operation. Among other important constraints are the maintenance of aseptic conditions during the culture and product recovery as well as the automatic operations.

Usefulness of bioprocessing can be demonstrated in production of one or more organic compounds of high scientific or medical value in a quantity applicable on Earth for at least experimental purposes.

In an attempt to define the most promising materials, Table I lists various organic compounds produced at 1-G by means of biosynthesis and physico-chemical recovery techniques on laboratory or industrial scale. Each process represents a type of metabolic pattern and has attractive features from experimental point of view.

Accordingly,

1. Production of cell mass (SCP) or ETOH on carbohydrates can be the subject of experiments of shifting metabolic pathway in favor of one product accumulation (NYIRI and KRISHNASWAMI) (24).
2. Biosynthesis of gluconic acid from glucose is a classical example of combined and staged activity of various cell-bound, cell-free enzyme systems as well as nonenzymatic conversion of an intermediate into final product. The process pathway is defined, therefore, comparative studies based on stoichiometry can be performed.
3. Production of oxytetracycline (OTC) has the combined characteristics of the former two processes (with the exception of nonenzymatic catalysis step). In addition, the problem of contamination is greatly reduced because of the wide spectrum of the antibiotic activity.
4. Biosynthesis of vitamin B₁₂ is an example of mixed culture operation incorporating complex growth and product formation kinetics.
5. Hormone production by animal cells (tissues). The process and its technology is currently under development.

As it is noted on Table I, with the exception of the first process, product recovery can be implemented either by chromatography or by electrophoresis.

ANALYSIS OF PROCESSES FOR SPACE BIOTECHNOLOGY

PRODUCT	PROCESS	MAIN PRODUCTS		TYPE OF RECOVERY		VALUE ^(A)		ANNUAL REQUIREMENT ^(B) (ESTD)
		PRIMARY (CELLS)	SECONDARY	#1	#2	#1 (CRUDE)	#2 (PURIFIED)	
1. SCP/ETOH	C.UTILIS SUBMERGED	25 g/L	ETOH:80 g/L	FILTR.	DIST.	1.9×10^{-3}	30×10^{-3}	10^6 T
2. GLUCONATE	P.OVALIS SUBMERGED	3 g/L	GA:40 g/L	FILTR. DIAL.	CHROM.	NIL	1.9×10^{-2}	10^4 T
3. OXYTETRA-CYCLINE	S.RIMOSUS SUBMERGED	8 g/L	OTC:30 g/L	FILTR. DIAL.	CHROM. EFO	NIL	2.5	10^3 T
4. VITAMINE	MIXED CULTURE SUBMERGED	6 g/L	B ₁₂ :0.3 g/L	FILTR. DIAL.	EFO	FEED	4.7	10^2 T
5. HORMONES	THYROTROPH MAMMOTROPH CELLS	10^9 CELLS/L	GH:0.5 g/L	DIAL.	EFO	?	4×10^3	0.1 T

(A) PRODUCT VALUE ESTIMATED FOR PROCESSING ONE LITER CULTURE LIQUID WITH A RECOVERY LOSS OF 25%.

(B) ESTIMATED POTENTIAL NEED IN USA.

NOTE: ESTIMATED VALUES ARE GIVEN: 1= \$US/L(KG); 2= \$US/100G; 3= \$US/KG; 4= \$US/KG; 5= \$US/G:

On the other hand, the absolute (scientific, commercial) value of products #1-#4 is low, whereas the desired quantity for application is relatively large. Even in the case of substantial improvement in biosynthesis (assuming fourfold increase in space) the needs can be fulfilled only with moving of large quantities of water.

Because of these considerations, any of the processes has short range of applicability and scientific value and can be used only in the testing stage of space biosynthesis and recovery equipment.

Product #5 has the advantage of experimental trial of eucaryote cell growth exposed to space environment as well as production of compounds of scientific and medical significance. In particular, production of certain hormones such as hormones from glands located in the brain (hypothalamus, pituitary gland), adrenal cortex, etc., may be listed here as prime candidates. In addition, electrophoresis is considered as the best means in separation of the protein and polypeptide compounds from the culture medium components (e.g. from serum). POSNER, in a short discussion (25) describes the most recent achievements (notably, direct relationship between cell mass and GH production, suspension culture of pituitary tumor cells, enhancing effect of hydrocortisone on GH production, release of hormones into extracellular liquid). With a potential increase of cell density to 10^{12} cells per liter from 10^9 cells per liter, gonadotropin hormone production can be substantially augmented (a cautious estimation is a fourfold increase in GH production). HIMMELFARB and his coworkers already reported 10^8 cells per ml in a perfusion-suspension apparatus (26).

Because of the complexity of hormone production, this process, however, can not serve as test method to obtain unquestionable answers on the effects of space environment on cellular and subcellular mechanisms.

4.2. MODEL REACTIONS FOR KINETIC STUDIES

Considering the above mentioned facts and problems, basic research is necessary to answer the following fundamental questions:

1. Does a space environment provide better, identical or inferior conditions for chemical or biochemical reactions at the cellular level?
2. Does a space environment affect the quality of the material obtained as a result of metabolic activity of cells?
3. As a conclusion of the series of tests: What manipulative advantage (fluid handling, diffusion controlled convection) appears most promising to perform biosynthesis and product recovery-purification in Space?

These questions are yet to be answered implementing well-planned and concise experiments resulting in statistically consistent data. This fundamental step in research is considered as a prerequisite for establishing a space bioprocessing program which has scientific and commercial significance.

Relative to the previous questions, the first question deals with the most fundamental problem area of material processing: reaction kinetics (the quantitative aspect of the process). The second question is related to studies on higher levels of cellular organization including concerted operation of several enzyme systems, their biosynthesis, and the effect of a space environment on cellular genetics (qualitative aspect of the process).

Accordingly, objectives of the experiments are:

1. Determination, within the limits of statistical accuracy, the characteristics and the direct or indirect effect of microgravity on selected biological reactions.
-

-
2. Developing techniques by which performance characteristics of space biosynthesis systems can be evaluated.

In order to meet these objectives, it is necessary:

1. To find a compound of biological significance which can be formed by 1) organic chemical synthesis (at least molecular rearrangement), 2) enzymatic catalysis involving no more than two enzymes, 3) direct biological activity of intact cells where 4) the product is extracellular (therefore can be removed by dialysis).
 2. The concentration of substrate, intermediate and/or product, can be monitored by at least one process sensor signal which reflects the reaction kinetics (without quenching or sampling the reaction mixture for wet chemical analysis).
 3. The reaction must be fast enough to cope with the limited time available in microgravity during the Sounding Rocket Flights (if the operational test of equipment is performed by this means), but the time length of the reaction can be extended by the increase of reactants' concentrations for Space Shuttle Flights as well as for Spacelab experiments.
 4. The reaction kinetics must be well-documented in 1-G gravity to serve the purpose of comparison.
 5. The reactants can not have toxic, flammable or otherwise hazardous characteristics.
 6. The reaction must be conducted with high precision in relatively small volumes to meet the payload requirements of the Sounding Rocket Programs (as a minimum requirement), but also be capable of scale-up for future Space Shuttle and Spacelab experiments or, even up to larger scales.
-

These objectives initiated a search to find a particular reaction. Numerous attractive biological systems were considered and rejected because of failing to meet one or more requirements. Both the model reactions listed in Table I and those proposed by other researchers (19) were evaluated. Evaluation patterns are listed in Table II, concluding that glucose-gluconic acid conversion is a candidate which meets criteria set forth. Therefore, we propose the glucose-gluconic acid conversion as a model system for the purpose of:

1. Kinetic studies conducted under both 1-G and O-G conditions to accurately determine the differences between the product formation rates and the absolute yield if the reaction is conducted in an essentially different environment.
2. Testing the bioprocessing system's performance from the viewpoints of capability 1) to help to synthesise and 2) to recover-purify organic compound as well as to perform automatic operations on the basis of on-line, real time acquired signals describing the process status.

This second purpose can be used to test the performance of all the prototypes developed during the experimental period.

GLUCONIC ACID (GA) PRODUCTION

CHEMICAL CHARACTERISTICS OF GA

Gluconic acid (synonyms: dextransonic acid, maltonic acid, glyconic acid, glyconic acid) is pentahydroxycaproic acid with the following formula (I):
($C_6H_{12}O_7$).

REACTION	MET REQUIREMENTS	FAILED TO MEET REQUIREMENTS
B. SUBTILIS SPORES + ALANINE → SPORE GERMINATION	4,5	1,2,3,6,
LACTOSE + E. COLI → β-GALACTOSIDASE	4,5,6	1,2,3,
GLUCOSE + O ₂ + YEAST → ETHYLALCOHOL	4,	1,2,3,5,6
GLUCOSE + BACTERIA → GLUCONIC ACID*	1,2,3,4,5,6	
AMP + 2(P ₁) + ENERGY → ATP	1.1,1.2,1.3, 5,6,	1,4,

* GLUCOSE CELLS, ENZYMES, ORG. CHEM.

→ GLUCONIC ACID 1-6

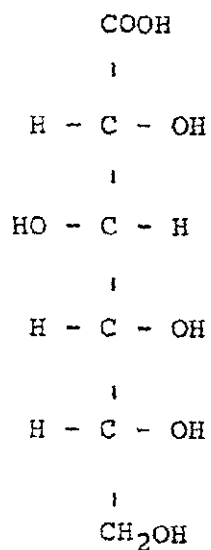

(I)

Main chemical characteristics are given as follows:

MW = 196.16,

FORM = CRYSTALS (although difficult to crystallize),

MP = 131° C,

K = 25×10^{-4} (at 25° C in H₂O),

COMPOSITION: C : 36.74%, H : 6.17%, O : 57.10%,

OPTICAL CHARACTERISTICS: $[\alpha]_D^{20} = -6.7^\circ$ (c = 1),

SOLUBILITY: Freely soluble in water,
Slightly soluble in ETOH,
Insoluble: ether,

CRYSTALLIZATION: Difficult,

CORROSIVITY: Corrosive against iron. Noncorrosive
against stainless steel (316 SS),

TOXICITY: None reported.

FORMATION OF GLUCONIC ACID

According to the literature (27), gluconic acid can be formed essentially in four ways:

- 1) By ionizing radiation of D-glucose,
- 2) Chemical synthesis from D-glucose,
- 3) Enzymatic conversion of D-glucose to gluconolactone which spontaneously hydrolyzes into gluconic acid,
- 4) Microbial conversion from D-glucose.

In all cases D-glucose is the starting material.

EFFECT OF IONIZING RADIATION ON D-GLUCOSE

This subject is of particular importance because since the ionizing radiation existing in Space may create side reactions which interfere with the interpretations of the experimental data.

According to PHILLIPS *et al* (28), when aqueous solution of D-glucose was irradiated with electrons generated by a van de Graff Generator (1Mv) at 1 A for 1 hour (energy input rate : 3.75×10^{20} ev/min) or with γ -rays (2.13×10^{17} ev/min - 3.65×10^{16} ev/min), D-glucose degraded to various compounds which may further react to give secondary products. Figure 1 shows the scheme of the degradation, whereas Table 3 presents

ORIGINAL PAGE IS
OF POOR QUALITY

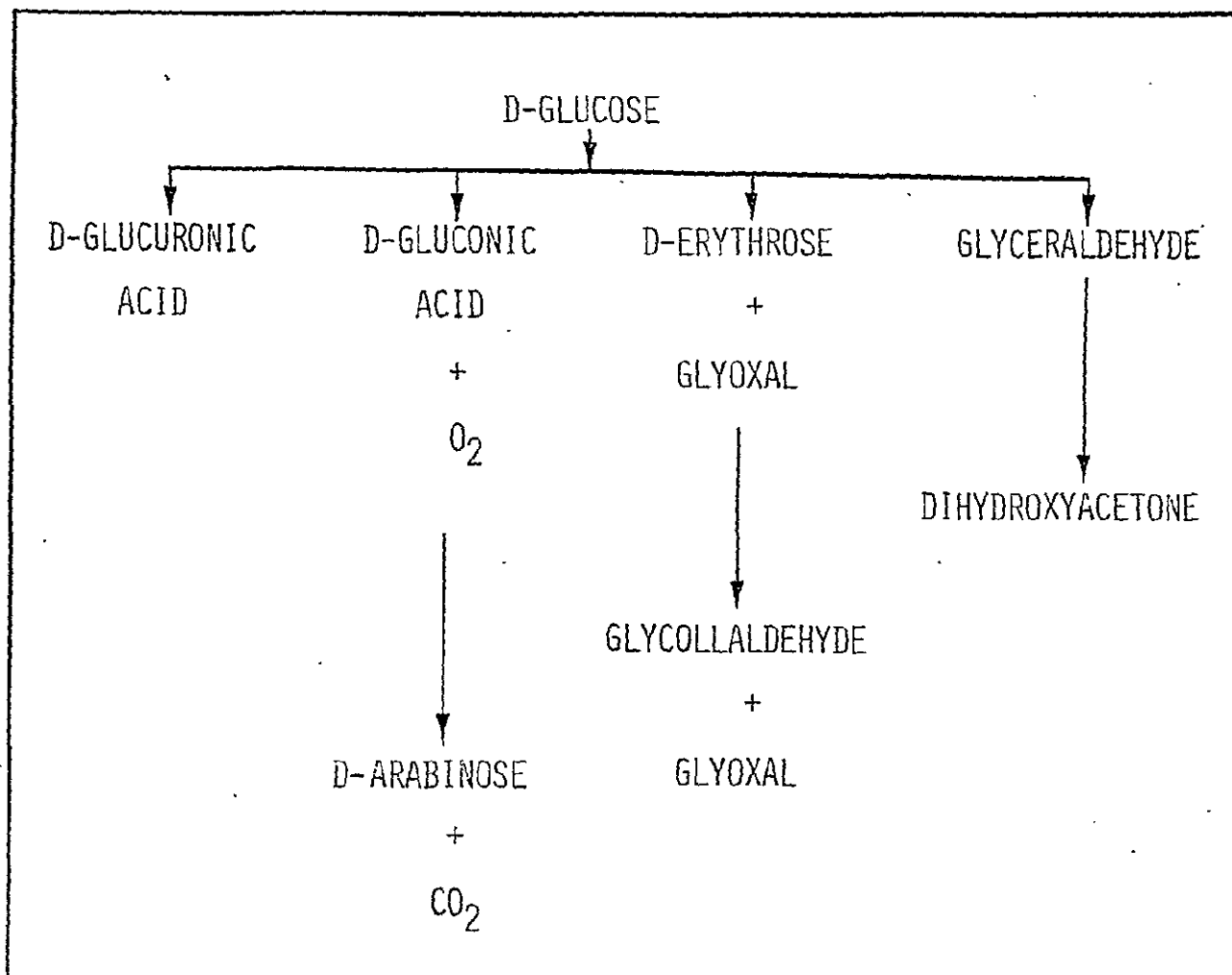

FIGURE 1
SCHEME OF D-GLUCOSE DECOMPOSITION DURING
 γ -IRRADIATION

Products when aqueous solution of D-glucose is irradiated with gamma radiation in oxygen.

(a) Initial glucose, 7.8 mmoles. Energy input, 4.6×10^{22} ev (volume 150 ml).

Product:	D-Glucose	D-Erythrose	Glyoxal	Formaldehyde	D-Gluconic acid	D-Glucuronic acid	Saccharic acid	
Carrier (mmole)	0.57	0.011	1.5	0.113	0.38	0.47	0.36	
Sp. activity (μ C per mmole) ...	4.1	3.44	0.60	0.012	2.8	0.71	0.03	
Fraction	Neutral	Neutral	Neutral	Distillate	Acid	Neutral	Neutral	
Yield (mmole)...	4.6	0.05*	0.64	0.005	0.24	0.45	0.012	
Corrected yield of glucose in whole irradiated solution							5.2 mmoles	
Corrected yield of glucuronic acid in whole irradiated solution							0.50 mmole	
D-Arabinose estimated from paper chromatography							0.30 mmole	

* Confirmed by estimation from paper chromatogram.

(b) Initial glucose, 5.5 mmoles. Energy input, 32.6×10^{22} ev (volume 115 ml).

Product:	D-Glucose	D-Erythrose	Glyoxal	Formaldehyde	D-Gluconic acid	D-Glucuronic acid
Carrier (mmole)	1.7	0.40	1.26	0.113	1.26	0.47
Sp. activity (μ C per mmole) ...	0.483	0.77	0.49	0.053	0.50	0.92
Yield (mmole) ...	1.13	0.22	0.96	0.147	0.63	1.01

D-Arabinose estimated from paper chromatogram, 0.6 mmole.

(c) Initial glucose, 11.07 mmoles. Energy input, 5.8×10^{22} ev (volume 100 ml).

Product:	D-Glucose	D-Erythrose	Glyoxal	Formaldehyde	D-Gluconic acid	D-Glucuronic acid
Carrier (mmole)	1.37	0.68	1.13	0.113	0.52	1.04
Sp. activity (μ C per mmole) ...	0.95	0.024	0.066	0.02	0.44	0.35
Yield (mmole) ...	7.05	0.09	0.85	0.05	0.44	0.60
		D-Arabinose	Saccharic acid	D-Xylose	Dihydroxyacetone	
Carrier (mmole)		1.04	0.35	1.88	1.19	
Sp. activity (μ C per mmole)...		0.099	6.8×10^{-3}	7.69×10^{-3}	0.068	
Yield (mmole)		0.45	0.016	0.06	0.31	

TABLE III
PRODUCTS ORIGINATED FROM D-GLUCOSE AFTER
 γ - IRRADIATION

(28)

the concentrations of the primary and secondary products. Although the detailed nature of the complex process is yet to be investigated, authors postulate that formation of D-glucuronic acid involved oxidation of the CH_2OH group while that of D-gluconic acid entails ring scission, and the former reaction appears to be favoured on the basis of the observed yields. D-Arabinose is probably formed from gluconic acid as a result of the secondary process involving OH radicals. A small amount of D-xylose doubtless arises from decarboxylation of glucuronic acid, though it does not appear to be the main secondary product arising from this acid. Similarly, the low yield of saccharic acid suggests that this is not the next stage in the oxidation of the gluconic and glucuronic acid. Another important primary degradation process is the formation of glyoxal by the initial cleavage between positions 2 and 3, and subsequently further contribution from other parts of the molecule. D-Erythrose, which is probably formed simultaneously with glyoxal is degraded extensively after its formation as indicated by its low yield. This may be a complex process, and may possibly involve the formation of further two-carbon fragments or D-glyceraldehyde. The main concentration of this product, however, arises from a primary breakdown of the hexose into two triose molecules. This is substantiated by the fact that dihydroxyacetone is formed immediately at low doses owing to the ready isomerisation of D-glyceraldehyde.

It is interesting to note that the yield of acid and pattern of degradation were not influenced by the glucose concentration (at least in the investigated range) and the dose rate as well as the presence of oxygen. This latter phenomenon and the postirradiation appearance of the H_2O_2 plus H_2 , CO , CO_2 gases hint that the chemical reactions are initiated by free radicals formed. GRANT and WARD (23) who performed irradiation experiments with D-glucose (also

n aqueous solution) in vacuum, using Co 60 γ -radiation (3.8×10^{16} ev/min) for 14 hours confirmed the former observations and added to the list of compounds (Figure 1) 2-oxo-D-arabino-hexonic acid and 2-oxo-D-arabino-aldohexose. The prolonged irradiation also indicated that gluconic acid is formed in the early stage of the irradiation and then undergoes an oxidative decarboxylation to yield D-arabinose + CO₂.

In addition to the significance of these findings with respect to the statistical accuracy of a biochemical-microbiological experiment in Space, the described experimental results draw our attention to the importance of analytical techniques (spectroscopy, electrophoresis, chromatography, potentiometric titration) by which products of such side reactions must be investigated.

CHEMICALLY CATALYSED FORMATION OF D-GLUCONIC ACID

Using D-glucose as starting material four processes were uncovered, all of them oxidizing S yielding D-gluconic acid (Figure 2).

1. Process patented by STOLL and KUSSMAUL (30) is based on former observations indicating that aldoses e.g. glucose can be oxidized to the respective monocarboxylic acid (e.g. gluconic acid) with hypobromite or hypoiodite. The process calls for D-glucose as substrate (240 G/1,000 ml distilled water) into which 123.2 G/L Ca(OH)₂ and 14 G/L NaBr is added. This mixture is then treated with 38 G/L chlorine gas which is cooled down (to an unspecified temperature, probably to +15° C). Reaction ends with the indication of disappearance of the oxidizing agent. Ca(OH)₂ can be substituted with Mg(OH)₂ and NaBr with hypoiodite. During the oxidation,

ORIGINAL PAGE IS
OF POOR QUALITY

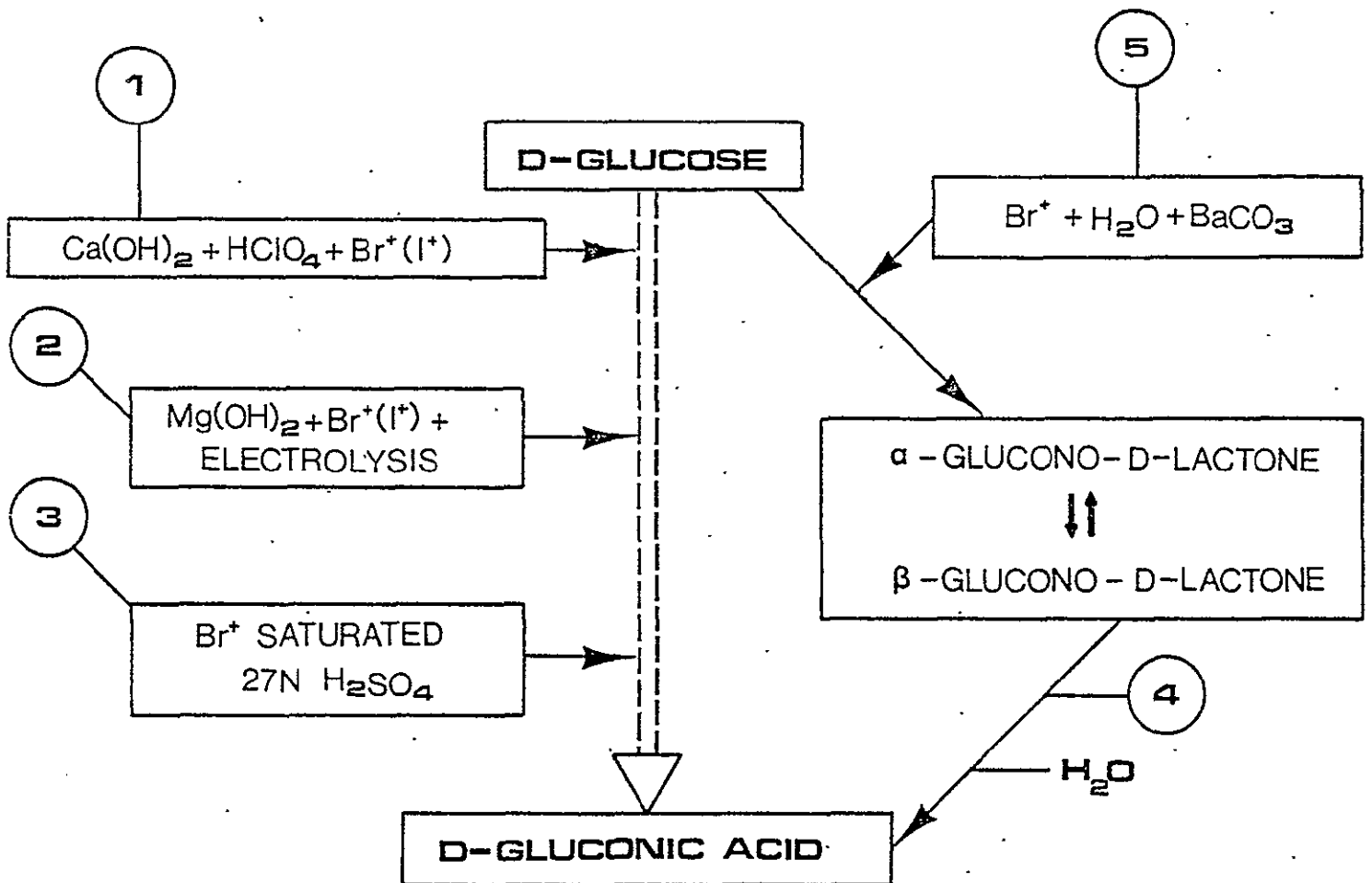
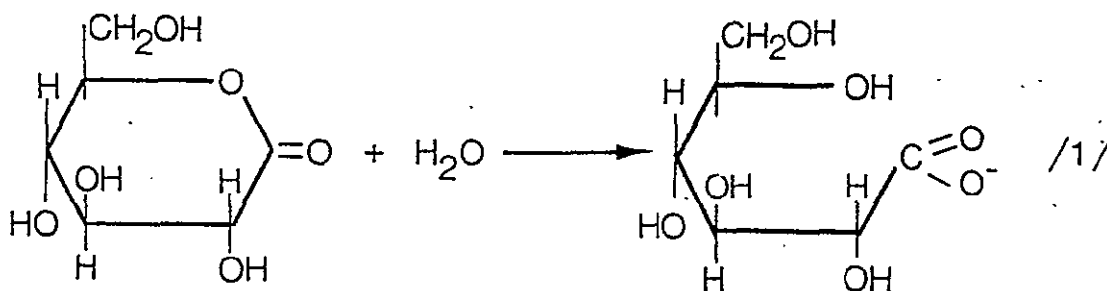

FIGURE 2.

CHEMICAL ROUTES IN D-GLUCONIC ACID PRODUCTION

intermediates probably appear, however, this aspect is not covered in the description.

2. Process described by HELWIG (31) improves the aforementioned technique by using electrolysis to facilitate the D-glucose - gluconic acid conversion. The technique calls for 200 G/L glucose, 20 G/L KI and 45 G/L $\text{Ca}(\text{OH})_2$ or Na_2CO_3 using water as solvent which are placed in a copper cup serving as cathode. A rotating graphite anode is then used with a current intensity of 75 A/m^2 at $10-15^\circ \text{ C}$. The process claims easier recovery of Ca-gluconate because of the absence of hypochlorite in the solution.
3. FOSTER and VARDHEIM (32) describes an observation whereby Bromine saturated 27 N H_2SO_4 can perform an oxidative hydrolysis of methyl α -D-glucopyranose into various acidic compounds, among other, traces of D-gluconic acid. In fact, the total amount of D-gluconic acid formed either from methyl α -D-glucopyranose or its decomposition intermedier, D-glucose is about 2-5 per cent of the starting material used.
4. Finally, D-gluconic acid δ -lactone can be spontaneously hydrolysed into D-gluconic acid according to the following reaction scheme:



GLUCONO-LACTONE

GLUCONIC ACID

D-gluconic acid δ -lactone ($C_6H_{10}O_6$) has the following characteristics:

MW = 178.14,

FORM = CRYSTALS,

MP = 153° C (dec.),

COMPOSITION - C 40.45%, H 5.66%, O 53.89%,

OPTICAL CHARACTERISTICS = $[\alpha]_D^{20} + 61.7^\circ \text{ C (C=1)}$,

SOLUBILITY: 59 G/100 ml dH₂O
1 G/100 G ETOH
Insoluble in ether.

Drop in pH during the hydrolysis: pH 3.6 \rightarrow 2.5
within 2 hours (27).

Structure in aqueous solution before the hydrolysis:

D-GA- δ -lactone \rightarrow D-GA- γ -lactone /2/

D-gluconic acid - γ -lactone can be produced from D-glucose using bromine water (33) (marked 5 on Figure 2), in presence of barium carbonate.

Evaluating the available possibilities to experimentally try the kinetics of chemical formation of D-gluconic acid under 1-G and O-G conditions, routes 1, 2 and 3 are excluded because of complexity (cooling, electrolysis) and the application corrosive materials (HClO₄, H₂SO₄).

The most promising technique is route 4 which 1) uses chemically well defined starting material, 2) hydrolysis may be followed by the decrease in pH (27), 3) the slope of the change in pH gives indication on the kinetics and 4) the technique can be expanded to start from D-glucose and observe the formation of the intermedier glucono-D-lactone as well as the formation of

Stoichiometry of the E_1 catalyzed reaction leading to P_1 can be depicted as:

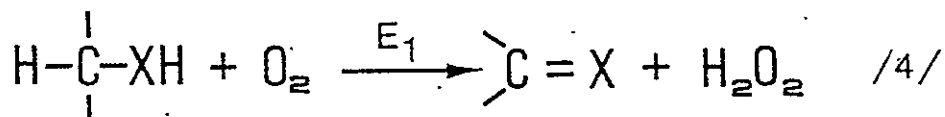

where (in the case of glucose oxidase) $-\text{XH} = -\text{OH}$, E_1 is the glucose oxidase and $\text{C}=\text{X}$ is P_1 , i.e. D-glucono- δ -lactone (L).

The other part of the reaction is the conversion of D-glucono- δ -lactone (P_1) into D-gluconic acid (P_2). This can be accomplished by spontaneous hydrolysis of P_1 into P_2 (35) or an enzyme, lactonase performs the reaction (36).

Hydrogen peroxide formed during the process can undergo spontaneous decomposition or catalase (EC.1.11.1.6) splits it into $1/2 \text{O}_2 + \text{H}_2$.

Because of the enzymatically facilitated electron transfer from the substrate to molecular oxygen (to form H_2O_2) the $\text{S} \rightarrow \text{P}_1$ step is composed of two half reactions, namely:

- a. Reductive Half-Reaction (RHR) where the fully oxidized enzyme (E_o) reacts with its substrate resulting in a sequence of steps:

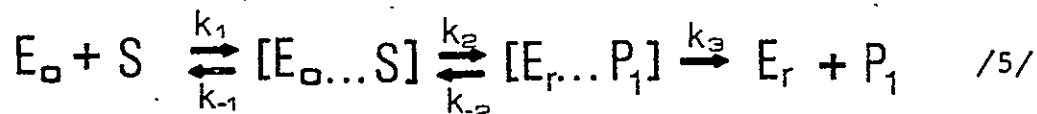

where E_o is the fully oxidized and E_r is the fully reduced state of glucose oxidase.

-
- b. Oxidative Half-Reaction (OHR), where the reduced enzyme transfers the electrons to the molecular oxygen:

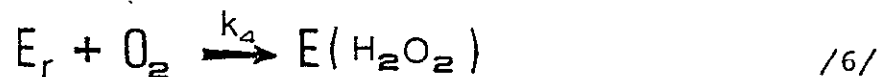

The $P_1 \rightarrow P_2$ ($L \rightarrow GA$) step either catalyzed by enzyme or performed by spontaneous hydrolysis is less complex from kinetics point of view, however, it yields the final product of interest: D-gluconic acid.

In accordance to this general scheme, the integrated stoichiometry of the enzymatically catalyzed decomposition of D-glucose into D-gluconic acid (with its side-reactions) is depicted in Figure 3. Because of this complex nature the two separate reactions leading to P_1 and P_2 , respectively, will be treated separately.

2. GLUCOSE OXIDASE CATALYZED REACTION

2.1. PROPERTIES OF THE ENZYME

Historically speaking, this enzyme was described as an antibiotic (notatin) originating from Penicillium notatum and Penicillium resticulosum sp. nov., however, later it was discovered that the H_2O_2 produced during the process had bactericidal effect.

Although several species of fungi and bacteria produce the enzyme, currently the best source is a fungus Aspergillus niger. Since most kinetic studies were performed with enzyme originating from A. niger, properties of this glucose oxidase will be given in the subsequent chapters.

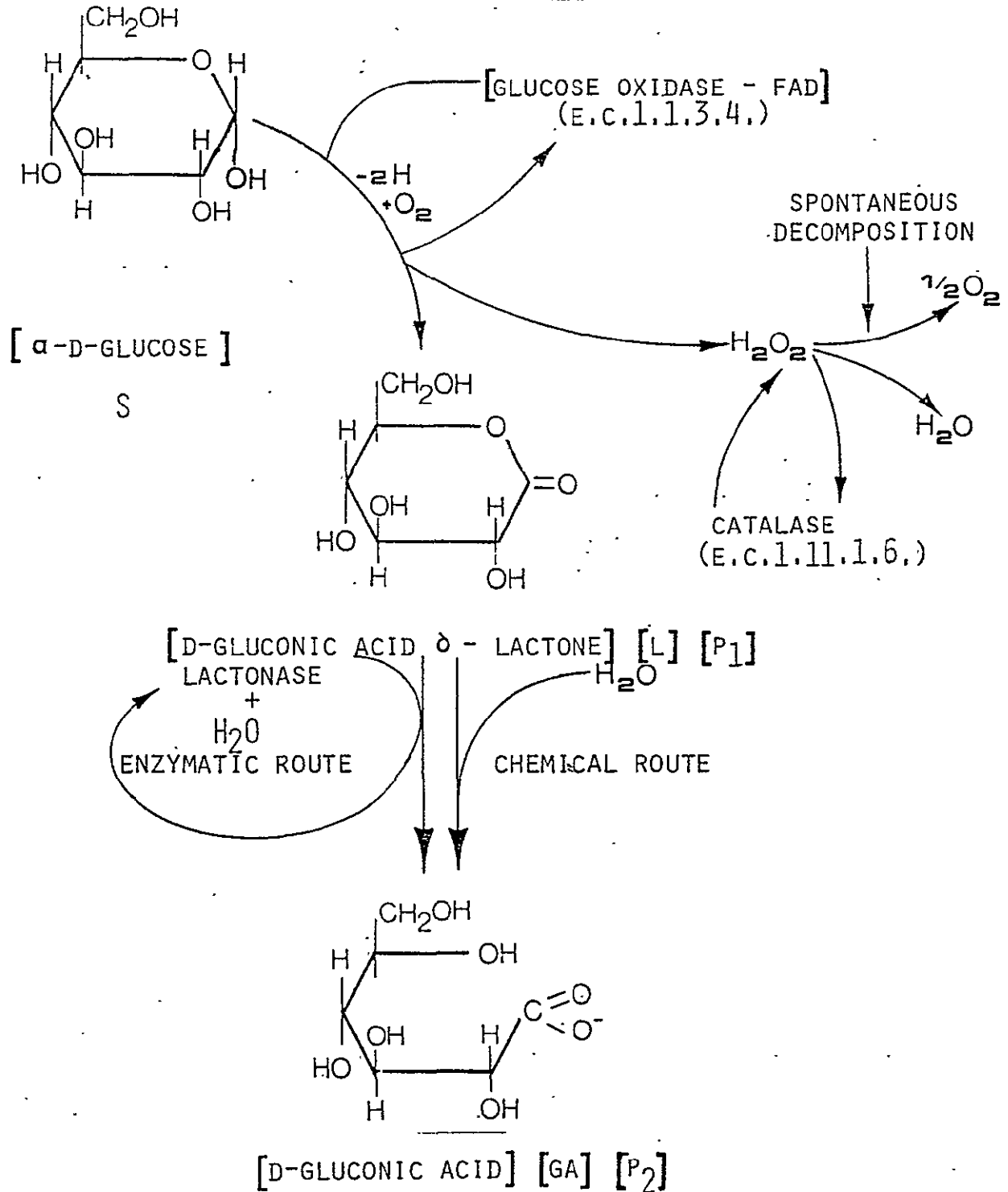

FIGURE 3

INTEGRATED PATHWAYS OF ENZYMATIC SYNTHESIS
OF D-GLUCONIC ACID

Chemical Composition - The enzyme is identified by various authors (38) as a glycoprotein containing two molecules of flavine adenine dinucleotide (FAD) as prosthetic group. Chemical structure of FAD (established by CHRISTIE and his coworkers (39) is given in Figure 4A with an indication of the possible chemical binding points with the enzyme (marked with arrows on the figure). Accordingly, the A. niger glucose oxidase is composed of a dimer having two tightly bound FAD molecules per dimer (40). YOSHIMURA and ISEMURA studied the chemical composition of glucose oxidase obtained from Penicillium amagasakiense (41) finding its molecular weight of 160,000 and each unit in the dimer composed of two polypeptide chains connected by a disulfide bond (Figure 4B). According to SWOBODA (42) binding of FAD was shown to be followed by at least one, and probably two, uni-molecular steps associated with protein conformational changes and it was proposed, on the basis of hydrodynamic and other measurements, that coenzyme binding converted the loose flexible coil configuration of the apoenzyme to a compact and almost spherical holoenzyme. Evidence for the sites of interaction on the FAD molecule was obtained from studies of the binding of a series of related nucleotides. The effectiveness of binding was such that it was proposed that the adenine and phosphate moieties of FAD are the first to bind, followed by the isoalloxazine nucleus. This later part of the holoenzyme is considered to play a key role in the reaction mechanism.

Chemical composition and reaction characteristics of FAD (38) which carries out the electron transfer result in absorption maxima in the range of 270-280 nm, 375-380 nm and 450-460 nm ranges (27). This fact plays an important role in the analysis of

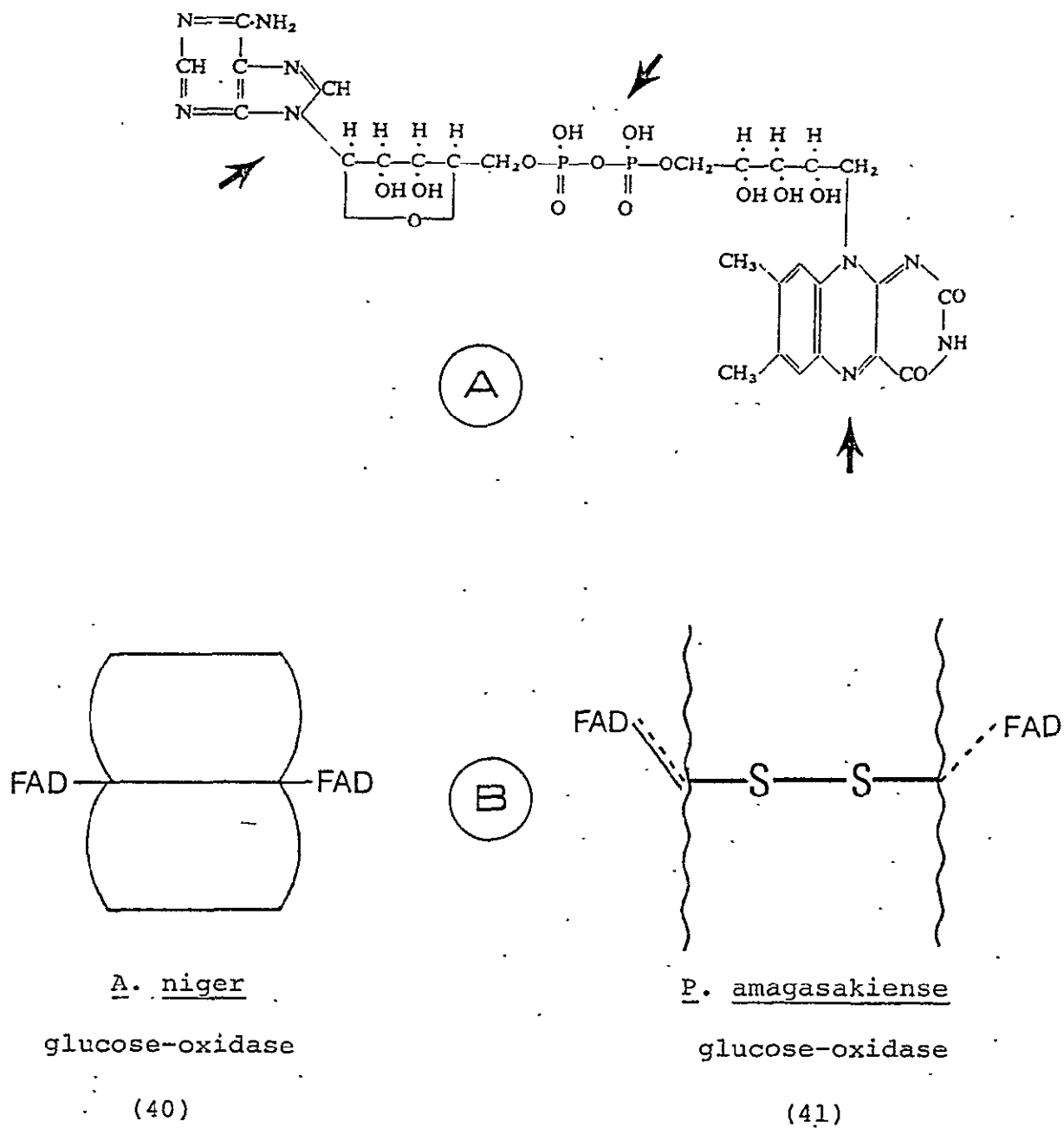

FIGURE 4.

(A) STRUCTURE OF FAD; (B) STRUCTURE OF
GLUCOSE OXIDASE

the reaction mechanism and kinetic behaviour of the glucose oxidase catalyzed $S \rightarrow P_1$ step.

MOLECULAR WEIGHT = 150,000 (43), 153,000 (42),

SPECIFICITY = Data are given in relative rates (38, 44): D-glucose, 100; D-mannose, 20; 2-deoxy-D-glucose, 20; effect negligible on other hexoses.

OPTIMUM ENVIRONMENTAL VARIABLES = Temperature ranges for reaction: 30-35° C, for stability: max. 40° C, pH ranges for reaction: pH 4-7 with a maximum at pH 5.5, for stability = pH 4.5-7.0 (45).

PHYSICAL CHARACTERISTICS = Amorphous powder or crystals. Solubility = freely soluble in dH₂O giving a yellowish-green solution.

Stability in storage and in aqueous solution immobilized enzyme. - WORTHINGTON claims storage without loss of activity for 6-12 months at +4° C (44). Dehydrated glucose oxidase was found by us to be stable at 0° C for 22 months without loss of activity (46). BENTLEY reported that the 0.1-0.2% aqueous solutions of the enzyme were stable for a week at +5° C (47). Enzyme solutions became increasingly unstable beyond the pH ranges of 3.5 to 8.0. The enzyme also exhibits resistance to thermal denaturation at temperatures up to 40° C but becomes unstable at temperatures higher than +40° C. BROUN *et al* improved the thermal stability of glucose oxidase by a procedure of cross-linking the enzyme with glutaraldehyde after its absorption into a cellophane membrane (48). This immobilized enzyme could be stored for up to 1 month at 20° C with no loss in activity. There was some narrowing of the pH activity curve from that of the soluble enzyme. WEETALL and HERSH also improved the

thermal stability of glucose oxidase by covalently bonding it to NiO on a nickel screen (49). The kinetic properties of the bound enzyme were similar to the soluble one. WEIBEL and BRIGHT reported the immobilization of glucose oxidase on porous glass using silanization and azo coupling techniques (50). Nearly 40 per cent of the enzyme protein absorbed on the glass surface remained enzymatically active. The loss of some activity could be attributed to diffusional resistance of the substrate(s) in the porous glass matrix. Application of immobilized enzyme system may be considered in spacecraft application because of its improved stability and because of fluid-mixing characteristics caused by 0-gravity conditions.

INHIBITORS = Ag^+ , Hg^{++} , Cu^{++} , P-chloromercuribenzoate and phenylmercuric acetate. FAD binding is inhibited with decreasing effectiveness by ADP, ADP-ribose, NAD, ATP, AMP, 2'-Deoxy ADP and adenosine (51).

CONTAMINATION = Glucose oxidase may contain impurities consisting of catalase (EC.1.11.1.6), proteolytic enzymes (27) and lactonase (36).

2.2. DETERMINATION OF GLUCOSE OXIDASE ACTIVITY, REACTION MECHANISM AND KINETICS

2.2.1. TECHNIQUES

During the period of investigation of reaction mechanism and kinetics several methods were developed, some of them were also used to determine the enzyme unit. The methods include 1) manometric technique, 2) spectrophotometry (fluorometry) 3) dissolved oxygen probe based kinetic analysis. Each method is described

here serving as possible technology for the enzyme mechanism and kinetic studies.

a. Manometric Technique

Buffers used: 0.1 and 0.13 M sodium phosphate buffer, pH 5.6 (52,53). GIBSON et al also cites use of 0.1 M sodium acetate buffer (53) of pH 5.6. No difference in results were observed as consequence of these two different applications. According to GIBSON et al (53) standard Warburg manometers were used. The rates of oxygen uptake in the presence of pure glucose oxidase and catalase (100 µg per manometer) were studied over a range of sugar concentrations (0.1 to 0.01 M) at pH 5.6, at 0° and 25°, and at different oxygen tensions. The gas space of the manometer was filled with either oxygen, air (21% oxygen), or 10.5% oxygen. In general, the amount of enzyme per manometer was adjusted so that oxygen uptake did not exceed 3 µl per minute. The manometers were shaken at a constant rate of 150 per minute. The oxygen uptakes over 25 minutes were used in calculating the rate of oxygen uptake, since the rates were constant for this time.

Limitation of the technique: It is obvious that a concentration gradient is required across the gas-liquid layer to permit the uptake of oxygen in a Warburg manometer. In many applications of manometry, this gradient may be disregarded, but not when the kinetics of an enzyme like glucose oxidase is under study, since the O₂ concentration in the liquid phase is one of the variables in the experiment. The oxygen concentration in the liquid phase is always less than that calculated from the tension in the gas and the solubility of oxygen, and may be estimated as given by ROUGHTON (54). When a constant rate

of oxygen has been reached, it may be shown that:

$$[O_2]_L = \alpha pO_2 [V_M - V] / V_M \quad //7//$$

where $[O_2]_L$ is the concentration of oxygen in solution, α is solubility coefficient of oxygen, pO_2 is the partial pressure oxygen in the gas phase, V is the rate of the enzyme reaction and V_M is the rate of the enzyme reaction at infinite enzyme concentration, *i.e.* when the rate is limited by diffusion of O_2 .

This equation has been used to estimate the errors inherent to the manometric experiments by limitation of O_2 ; GIBSON *et al* indicated that with particular experimentations, errors in rate measurements are less than 5% within up to 5 μ l per minute with air in the flasks. With lower O_2 percentages, accurate manometry is scarcely feasible, however, corrections can be made. In no case did these corrections exceed 5% of the value measured.

Besides the possible inaccuracies, another limitation in space oriented research is the size and complexity of a Warburg manometer.

b. Spectrophotometric Analysis

Because of the characteristic absorption maxima in the visible and UV ranges, spectrophotometric analysis is possible for following the course of the reaction carried out by the flavin part of the enzyme. Also, H_2O_2 formation could be followed spectrophotometrically through its weak tail absorption at 235 nm. This technique, however, needs 0.1 absorbance sensitivity and perfect resolution from the absorbancy of enzyme-bound

FAD and FADH₂ at this wavelength (38). Generally, the spectrophotometric analysis is performed at 450 nm with tungsten light source using 0.1-0.13 M sodium phosphate buffer, pH 5.6 (53). A technique called stopped-flow spectrophotometry was developed (55) the essence of which is described as explanation beneath Figure 5 (after GIBSON et al (53)).

With this technique transient-state kinetics can be measured with respect of the two half reactions (Eqs. /5/ and /6/) in the following way:

1. RHR is carried out anaerobically in the stopped-flow spectrophotometer by mixing E₀ with S and monitoring the change of enzyme state at 450 nm. Changes at this wavelength are shown in Figure 5. The total number of times that the enzyme must turn over to exhaust the added oxygen can be calculated from the conditions of the experiment and this number is correlated with the area enclosed by the curve in Figure 5.
2. OHR is carried out by mixing E_r (usually prepared anaerobically by reducing E₀ in presence of low concentration of S) with O₂ and monitoring the appearance of oxidized enzyme at 450 nm. In fact, a curve with a reversed shape shown in Figure 5 ought to be obtained.

From the method of carrying out the stopped-flow half-reactions we refer to WEIBEL and BRIGHT's paper (56) which describes the technique in detail.

The combined spectrophotometric and stopped-flow techniques were widely used in the reaction

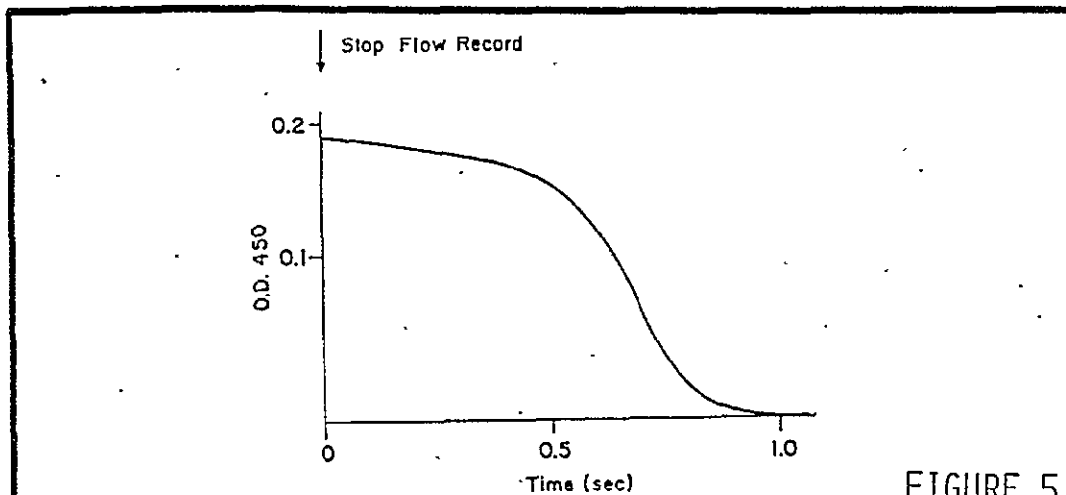

FIGURE 5

Reproduction of oscillograph trace obtained with stopped flow apparatus in following the reaction between glucose and oxygen. At the time shown by the arrow, a solution of enzyme in equilibrium with 1 atmosphere of O_2 was mixed with an equal volume of O_2 -free 0.1 M glucose. The reaction was followed in a 2-cm light path at 450 $m\mu$, at 0° in 0.13 M phosphate buffer, pH 5.6; the concentration of enzyme was 1.17×10^{-6} M.

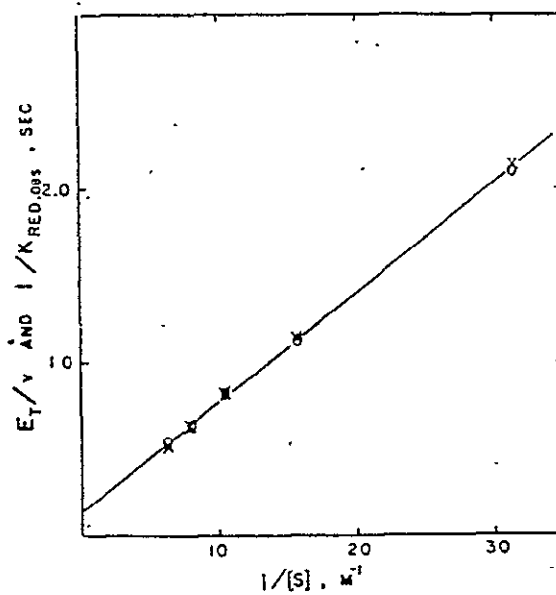

FIGURE 6

Comparison of stopped flow reductive half-reaction data (E_T/v , x) with O_2 monitored turnover data (E_T/v , O) at pH 10, 0.1 M total fluoride.

mechanism and kinetic studies (38) with satisfactory results. In our proposed practice it can be utilized only if the crew of the Space Shuttle or Spacelab is skilled in preparation of the enzyme species and carrying out the spectrophotometric analysis. The current sizes of spectrophotometers (e.g. B & L Minispec 20) do not handicap this possibility.

3. Monitoring Oxygen Concentration - The essence of the experiment is the measurement of the time which is needed to exhaust the dissolved oxygen in a reaction mixture containing known amount of substrate and enzyme. By this means the turnover of the enzyme can be determined. The technique as described by WEIBEL and BRIGHT is as follows (56):

A Clark electrode, power source, and amplifier assembly were obtained from Yellow Springs Instrument Company, Yellow Springs, Ohio. The electrode chamber was thermostated at 25° and a 10-inch Beckman recorder was used. A 3-ml aliquot of the appropriate glucose solution was equilibrated by rapid stirring for 5 min. with air or by bubbling O₂ into the chamber. The value used for O₂ solubility in pure water at 25° and total pressure of 760 mm is estimated to be 1.21×10^{-3} M. O₂ concentrations in dissolved air were referenced to this value and appropriate barometric correction were made when significant. Low buffer and glucose concentrations were used when possible in order that the O₂ activities measured by the electrode reflect actual oxygen concentrations. No corrections were made for salt effects on the solubility of O₂ in the halide experiments as the maximum concentration of salt was 0.1 M and would only amount to a maximum error of 3%.

Addition of enzyme was made to the system through a groove in the electrode holder using Hamilton syringes. Since the data obtained are integral in nature, integrated rate equations for turnover were used. It was found that a simple three parameter equation (Equation 8) was adequate to fit all data at the 1% level for a given pH. Equation /8/ is the integrated form of Equation /9/.

$$[E]_t = (1/k_{red}) \ln ([S]_o / ([S]_o - ([O_2]_o - [O_2]_t))) + (1/k_{ox}) \ln ([O_2]_o / [O_2]_t) + (1/k_{cat}) ([O_2]_o - [O_2]_t) \quad /8/$$

$$E_r/v = 1/(k_{red} [S]) + 1/(k_{ox} [O_2]) + 1/k_{cat} \quad /9/$$

These equations are based on a minimal mechanism involving two biomolecular steps and one monomolecular step in the turnover sequence.

The integral data from measurements at 10 or more glucose concentrations, in which O₂ had been 80% depleted, were fitted by Equation /8/ by optimizing the three rate parameters.

With this technique pH dependency as well as effect of halides on the reaction rate were investigated. Correlation between the stopped flow half-reaction experiments and the oxygen probe monitored turnover rate were found to be excellent (Figure 6) and indicated that the turnover reaction is zero-order, hence Eq. /9/ can be reduced to Eq. /10/:

$$E_T/V = \frac{1}{(E_{red} [S] + 1/k_{cat})} \quad /10/$$

Technique using on-line direct measuring DO probes seems to be an acceptable means to follow reaction kinetics in Earth-bound and Space experiments. In addition, changes in oxidation-reduction potential (ORP) are also considered as excellent means to define the half-reaction kinetics. ORP sensors (alike to DO sensors) are available and are extensively used to monitor biochemical redox reactions related to both microbiological biochemistry and animal cell culture physiology (57). ORP measurement, however, was not tried so far in connection with glucose oxidase kinetics measurement.

2.2.2.

DEFINITION OF ENZYME UNIT

- a. SCOTT defined the unit as follows (27):
"A glucose oxidase unit is defined as that quantity of enzyme which will cause the uptake of 10 mm^3 oxygen per minute in a Warburg monometer at 30° C in the presence of excess air and excess catalase with a substrate containing 3.3% glucose monohydrate (33 G/L) and 0.1 M phosphate buffer at pH 5.9 with 0.4% (4 G/L) sodium dehydroacetate".
- b. An other definition of unit is given by WORTHINGTON (44). This is based on a spectrophotometric assay. Accordingly "one unit glucose oxidase is that amount of enzyme liberating one micromole of H_2O_2 per minute at 25° C ." Because of its convenience (application of spectrophotometer) this assay is widely used and is described lege artis from the WORTHINGTON Manual (44).

REAGENTS

Enzyme: Aqueous solution containing 1-4 micrograms per ml.

Buffer: 0.1 M phosphate, pH 6.0.

Coupling enzyme: Aqueous solution of purified horseradish peroxidase containing 60 units/ml.

Dye: 1% aqueous solution of o-dianisidine.

Substrate: 18% solution of glucose allowed to come to equilibrium of mutarotation.

PROCEDURE

Add 0.1 ml of o-dianisidine solution to 12 ml of buffer and place the following into cuvettes at 25° C. Zero instrument at 460 nm vs control cuvette.

	Test	Control
Dye-buffer	2.5 ml	2.6 ml
Glucose	0.3 ml	0.3 ml
Peroxidase	0.1 ml	0.1 ml
Enzyme	0.1 ml	-

Record increase at 460 nm for 2-4 minutes.

CALCULATION

$$\text{units/mg} = \frac{D \quad 460/\text{min}}{11.3 \text{ X mg enzyme/ml reaction mixture}}$$

It is noted that because of the hardware requirement (case #(1)) and the necessity to prepare

samples (case # (2)) these assays can be used only for determination of purity of enzyme preparations and are considered to be inadequate for kinetic analysis.

2.2.3. KINETICS OF D-GLUCOSE—D-GLUCONO- δ -LACTONE STEP

Kinetic strategy includes two classes of operations, namely: 1) Steady-State Kinetics Study and 2) Transient-State Kinetics Study. For the first operation the O_2 electrode based technique can rapidly generate data with relatively high precision. For the second operation the spectrophotometric (stop-flow) technique was found to be excellent since the flavin chromophore is an intrinsic spectrophotometric probe itself (58). In this second case the reaction is broken into two-half reactions (c.f. p. 51) which are studied separately.

1. Steady-State Velocity Measurements - According to Eq. /11/ the reaction takes place as follows:

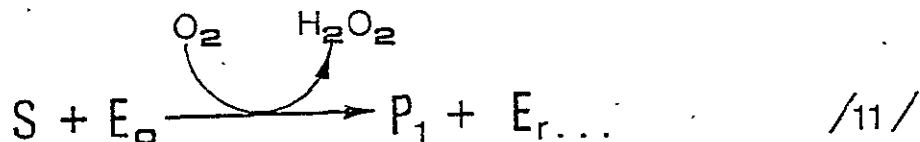

Therefore, the steady-state initial activity can be monitored through the changes in S, O_2 , H_2O_2 , P_1 concentrations (c.f. analytical methods cited above). A major source of error can come from contamination with catalase where Eq. /11/ is modified to:

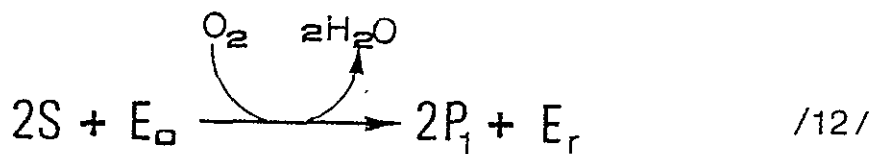

Consequently, Eq. /11/ can be achieved in presence of an effective catalase inhibitor (e.g. - CN) which is inconvenient and halves the sensitivity of O₂ probe based measurements. Our particular application, therefore, calls for a quality control check for catalase-free glucose oxidase to assure the implementation of kinetics described in Eq. /9/.

According to BRIGHT and PORTER (34) the O₂ electrode trace, at a given concentration of S (which remains effectively constant during the kinetic experiment) provides an infinite set of steady-state velocities as a function of O₂ concentration. Such data may be evaluated by the method of tangents or they may be analyzed through the integrated rate equation by computer or by manual methods. When these methods are valid, two complete sets of steady-state graphs of high quality can be obtained from as few as four or five kinetic experiments. In addition to rapid evaluation of the steady-state coefficients such experiments have the advantage of providing, through rapid inspection of the O₂ trace, useful qualitative information concerning the relative magnitudes of $\Phi_1 / [S]$ and $\Phi_2 / [O_2]$ in the steady-state equation. If $\Phi_1 / [S] \ll \Phi_2 / [O_2]$ (and if both are larger than Φ_0) the O₂ electrode trace is highly curved.

This shows immediately that the interaction of O₂ with a reduced species of enzyme is a principal rate-determining process in turnover. If the opposite is true, the steady-state velocity remains independent of O₂ and the O₂ electrode trace has constant slope.

Due to this technical condition the steady-state turnover data can be obtained as tangents to the entire O₂ electrode trace, usually plotted in double reciprocal fashion as $(E_r)/v$ versus the reciprocal of the variable substrate (O₂ or S) at different levels of the fixed substrate (S or O₂) (see Figure 6). The pair of primary plots usually consists of sets of parallel lines and the lines are commonly straight (see Figure 6).

If these parallel (straight) line patterns are obtained the steady-state rate equation corresponding to Eq. /11/ can be expressed as:

$$\frac{Er}{v} = \Phi_0^{-1} + \frac{\Phi_1}{[S]} + \frac{\Phi_2}{[O_2]} \quad /13/$$

where Φ_0^{-1} is the maximum turnover number (in sec^{-1}) and Φ_1^{-1} and Φ_2^{-2} are apparent bimolecular constants with units of $\text{M}^{-1} \text{sec}^{-1}$.

Notation Φ for expression of steady-state rate equations is recommended by BRIGHT and PORTER (34) because of the close correspondence of the coefficient to rate constants obtained from stopped-flow experiments (c.f., again Figure 6). It is noted, however, that: any substrate scheme will give Eq. /13/ if it contains, minimally, one first-order (corresponding to Φ_0^{-1}) and two second-order (corresponding to Φ_1^{-1} and Φ_2^{-1}) kinetic processes and if, in addition, along the pathway linking the two enzyme species which bind S and O_2 , there is at least one process which is irreversible (or practically so) under the conditions of the experiment. The simplest possible scheme consistent with Eq. /13/ is, therefore, that of Eq. /14/ where the first-order process may terminate either of the half-reactions:

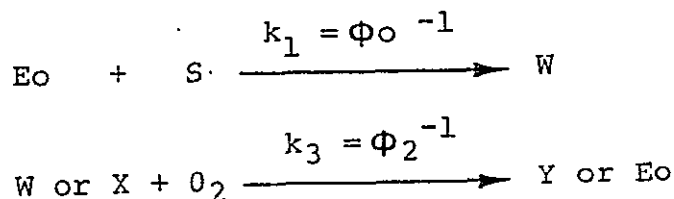

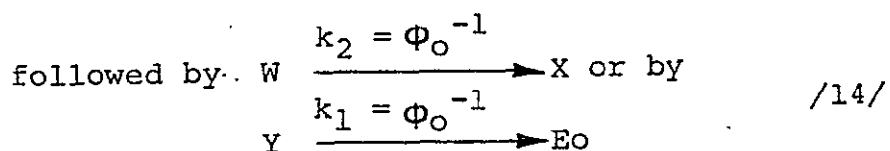

If n rate-limiting first-order processes are located in either or both of the half-reactions, then the maximum turnover number becomes:

$$\Phi_0^{-1} = \sum_{i=1}^n \left(\frac{1}{k_i} \right)^{-1} \quad /15/$$

It is quite evident that no decisions concerning mechanism, beyond the generalities just stated, can be made at this point. However, the steady-state rate equation, together with the evaluated coefficients, are indispensable for the correct interpretation of the rapid kinetic measurements. This is because the kinetics of each transient in the rapid kinetic measurement must correspond to one or more of the steady-state coefficients if the transient enzyme species is an obligatory intermediate in turnover.

According to experimental results obtained from various sources (34) glucose-oxidase turnover always conforms to Eq. /13/.

Using O_2 sensors integrated steady-state rate equation can be obtained. The conditions of the experiments ($S \gg O_2$) force each trace to obey Eq. /16/:

$$\frac{[E_T]}{v} = A + \frac{B}{O_2} \quad /16/$$

Integration of this equation yields Eq. /17/:

$$\frac{1}{t} \ln \frac{O_{20}}{O_2} = - \frac{A}{B} \frac{[O_2]_0 - [O_2]}{t} + \frac{[Er]}{B} \quad /17/$$

Comparison with Eq. /12/ shows that $B = \Phi_2$ and $A = \Phi_0 + \Phi_1 / [S]$. Plots of A vs. $1/S$ will therefore yield Φ_0 and Φ_1 . Although the conditions for the valid use of Eq. /17/ are strict (no product of any kind must interact reversibly with any enzyme species), the greater precision of integral, as opposed to differential, data allows for very accurate evaluation of the steady-state parameters.

2. Transient-State Kinetics: The Half-Reactions - Reductive Half Reaction (RHR) takes place according to Eq. /5/. In case of glucose-oxidase RHR only the fully oxidized and the fully reduced species of enzyme can be observed spectrophotometrically. RHR is therefore monitored at 450 nm where E_0 and $[E_0 \dots S]$ absorb maximally relative to E_r . $[E_r \dots P]$ if it has significant lifetime, must have the same spectrum as E_r . If the system is saturated with S, then:

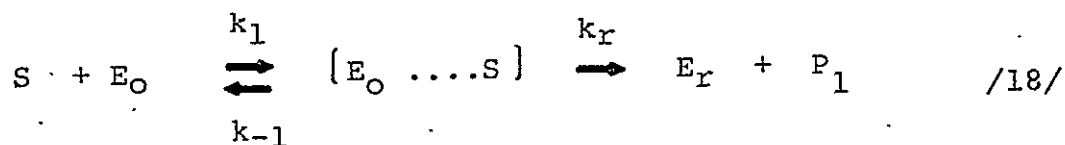

and the kinetic equation is expressed as:

$$\frac{1}{k(\text{obs})} = \frac{1}{k_2} + \frac{k_{-1} + k_2}{k_1 k_2 [S]} \quad /19/$$

According to this, it is anticipated that the plot of $1/k$ (observed) versus $1/S$ is linear indicating that k_{-1} is zero. Whether the rate of dissociation of P_1 from $[E_r \dots P_1]$ is actually very rapid as implied by Eq. /18/ is not known so far (34).

Oxidative Half Reaction (OHR) takes place according to Eq. /6/. As is the case with $[E_r \dots P_1]$ in the glucose oxidase RHR the presence and lifetime of $[E_o \dots H_2O_2]$ is not detected in the OHR experiment because there is no spectrophotometric change following the oxidation of the flavin.

3. Integrated Kinetic Mechanism

On the basis of experimental results accumulated so far for flavoprotein oxidase reactions (34), Figure 7 presents an integrated kinetic mechanism which may be operative in the case of these enzymes. Accordingly, two major pathways exist in regeneration of the reduced flavoprotein in one turnover cycle. In cycle (A) enzyme complex $[E_r \dots P_1]$ releases the product (P_1) and then the still reduced enzyme is oxidized forming a $[E_o \dots H_2O_2]$ intermediate which is decomposed into E_o and H_2O_2 . In cycle (B) the $[E_r \dots P_1]$ complex undergoes oxidation resulting in H_2O_2 , then the oxidized enzyme parts with P_1 to yield the reactive E_o again.

Identical results between the transient and steady-state kinetic parameters (34) definitely establish Eq. /18/ as an obligatory reaction sequence in turnover. They also establish that Φ_1 is independent of enzyme concentration (at least in the range of 10^{-8} to 10^{-5} M where the experiments were performed) and if there is one FAD per active site. GIBSON *et al* (53) found $\Phi_2 - 1 = k_4$ for glucose as $[S]$. This identity establishes $E_r \rightarrow E_o (H_2O_2)$ as an obligatory pathway in the turnover. Also, enzyme monitored turnover experiments (SSK(E)) made it possible to determine Φ_o (53), however, we feel it is not necessary

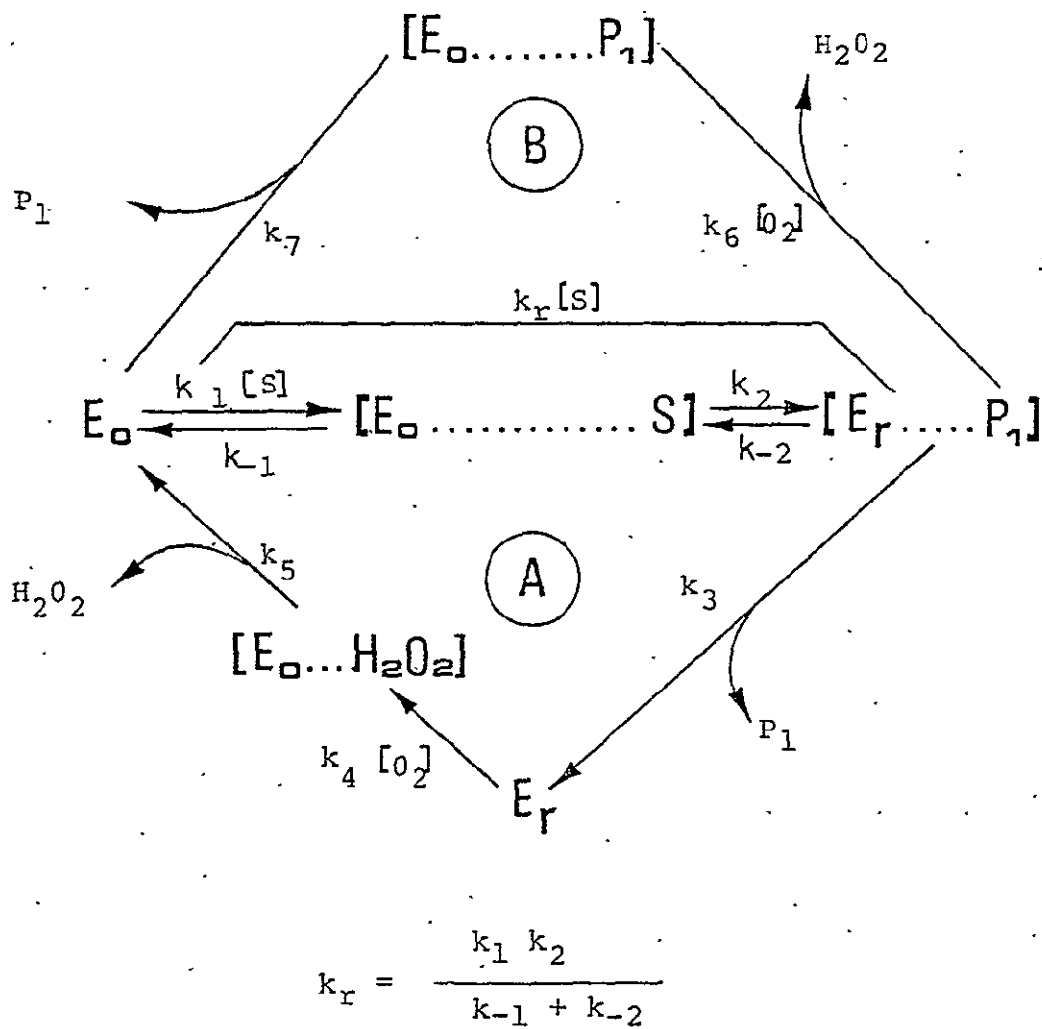

FIGURE 7

ASSUMED KINETIC MECHANISMS FOR FLAVOPROTEIN OXIDASES

to use spectrophotometry based stopped-flow technique because the turnover number v/E_T can be computed at any concentration of O_2 by the method of tangents if $[S] \gg [O_2]$.

Accordingly, the overall kinetic equation for glucose oxidase, if catalytic cycle (A) is operative, is summarized as:

$$\frac{[E_T]}{v} = \frac{k_5(k_1+k_2)+k_2k_3+k_3k_5}{k_2k_3k_5} + \frac{k_3(k_{-1}+k_2)+k_{-1}k_{-2}}{k_1k_2k_3[S]} + \frac{1}{k_4[O_2]} \quad /20$$

which equation conforms to the experimental results obtained with glucose and expressed in Eq. /13/.

Considering all of the experimental results compiled so far with respect to glucose + glucose oxidase interaction catalytic cycle (A) is the most probable hypothesis (34).

3. GLUCONOLACTONE-GLUCONIC ACID CONVERSION

Completion of D-glucose D-gluconic acid conversion requires the hydrolysis of D-glucono- δ -lactone (P₁) produced by glucose oxidase. According to Eq. /3/ this step is performed by spontaneous hydrolysis or the process can be catalyzed by an enzyme, lactonase. This step was not studied in detail from reaction mechanism and kinetics point of view.

Reaction mechanism. Chemical hydrolysis.

Formation of gluconic acid from D-glucono- δ -lactone requires a cleavage on the C-O bond with an uptake of H^+ and OH^- ions. The mechanism Eq. /11/ assumedly follows the classical path of hydrolysis processes (59).

Reaction Mechanism. Enzyme Catalyzed Process

Enzyme, gluconolactonase was described by BRODIE and LIPMAN (36) from *S. cerevisiae* (yeast), bacteria (not specified), rat liver. The enzyme protein was purified 36-fold from yeast cells and catalyzed the following reaction:

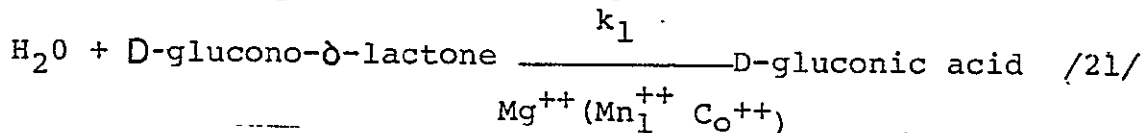

Dependency on bivalent cations was proven. Compared to the non-enzymatic hydrolysis (which was found to be 0-order) the enzymatic reaction was of 1st-order nature. Reaction rate constants for D-glucono- δ -lactone were found (pH = 7.0; T = 30°C): $K_s = 8.5 \times 10^{-3}$ moles/ml; $k_m = 5 \times 10^{-3}$ moles/ml. 6-phospho-glucono- δ -lactone is also described as substrate for enzymatic reaction. The enzyme's activity was inhibited by NaF, sodium benzoate, hexylresorcinol (in 4×10^{-3} M concentration).

Out of this relatively small information the following conclusions can be drawn:

1. The order of the enzymatic reaction indicates a monomolecular catalytic scheme. It seems possible that (depending on the enzyme concentration) both the nonenzymatic and the enzymatic pathways exist simultaneously.
 2. The initial steps of the pentose-shunt contain enzyme capable to convert glucose-6-phosphate (DGL6P). This compound is then converted into D-gluconate-6-phosphate by an enzyme called phosphogluconolactonase. Yeast and bacterial lactonase had the capability to perform this latter step, acting upon DGL6P. It is conceivable therefore that phosphogluconolactonase
-

also has the capability to use nonphosphorilated D-gluconolactone as substrate.

A pentose shunt operates in *A. niger* (60). Consequently, phosphogluconolactonase may be present as a contaminant in glucose oxidase preparations obtained from *A. niger*.

5.2.4. MICROBIAL SYNTHESIS OF GLUCONIC ACID

1. GENERAL DESCRIPTION

First reported information on the microbial formation of gluconic acid from glucose comes from BOUTROUX (61). Since this time species of several genera were found to possess the capability to oxidize the aldehyde group of D-glucose to yield finally gluconic acid. A list of the species reportedly having this capability is given in Table IV. In the case of molds, certain filamentous fungi have the enzyme structure to convert D-glucose to D-gluconic acid, whereas bacteria belonging to the family Pseudomonadaceae particularly Acetobacter (to a lesser extent) and Pseudomonas genera (to a larger extent) show capability of bioconversion of D-glucose into gluconic acid. Most of the species have the capability to further oxidize gluconic acid into 2-ketogluconic acid which fact, in our case, may serve as a disadvantage for proper kinetic studies. However, LOCKWOOD et al reported that P. ovalis lacks the enzyme system responsible for D-gluconic acid 2-ketogluconic acid conversion (68). Because of this property P. ovalis was used in most of the kinetic studies (72-75) conducted so far with respect to D-glucose-gluconic acid conversions. On the other hand Aspergillus niger and Penicillium chrysogenum species were generally applied to

TABLE IV
LIST OF MICROORGANISMS WITH CAPABILITY TO PRODUCE
D-GLUCONIC ACID FROM D-GLUCOSE

MOLDS

- Aspergillus fumaricus (64, 65)
Aspergillus niger (40, 62, 63)
Penicillium amagasakiense (41)
Penicillium chrysogenum (65, 66)
Penicillium luteum purpurogenum (67)
Penicillium notatum (37)
Penicillium resticulosum sp. nov. (37)

BACTERIA

- Acetobacter aceti (Mycoderma acti) (61)
Agrobacter tumefaciens (68)
Corynebacterium michiganese (68)
Bacterium gluconicum (63)
Bacterium hoshigaki var. rosea (69)
Bacterium hoshigaki var. glucuronicum (69)
Bacterium (Pseudomonas) sovastoni (70)
-

TABLE IV
(CONTINUED)

<u>Bacterium xylinoides</u> (69)
<u>Bacterium xylinum</u> (69)
<u>Pseudomonas coronafaciens</u> (68)
<u>Pseudomonas mucidolens</u> (68)
<u>Pseudomonas myxogenes</u> (68)
<u>Pseudomonas ovalis</u> (68)
<u>Pseudomonas putidum</u> (71)
<u>Pseudomonas striafaciens</u> (68)
<u>Pseudomonas syringae</u> (68)
<u>Xanthomonas begoniae</u> (68)
<u>Xanthomonas campestris</u>
<u>Xanthomonas stewarti</u> (68)

industrial scale production of gluconic acid (Table V) (63,65), with yield factors of 0.55-0.971 ($Y = \text{gm product produced/gm substrate consumed}$). The long fermentation time, however, may exclude the use of filamentous fungi for Space Shuttle and Spacelab experiments.

Assumed metabolic pathway in microbial D-glucose-D-gluconic acid conversion

Figure 8 describes the overall scheme of gluconic acid formation in presence of microbial cells (X). Accordingly, the substrate(s) α -D-glucopyranose is oxidized by glucose oxidase (E. C. 1.1.3.4.) into D-glucono- δ -lactone intermedier (L) which is further hydrolysed into the product (P) gluconic acid. The glucose oxidase activity is FAD dependent (c.f. 5.2.3.) where the coenzyme acts as the first electron acceptor in the terminal oxidation chain. The enzymatic system in P. ovalis is intracellular which assumes the transportation of substrate through the cell wall. Since the product is extracellular there are two possibilities for the cell wall transport: 1) the intermedier leaves the cell and then its hydrolysis takes place extracellularly or 2) spontaneous hydrolysis takes place intracellularly and the D-gluconic acid ($R-COO^-$) leaves the cell. In this latter case the release of a compound with carboxyl ion may need the uptake of an anion in order to insure the ionbalance across the cell wall. Hydrogen peroxide as the by-product of the D-glucose D-glucono- δ -lactone reaction is cleaved into $H_2O + 1/2 O_2$ by catalase enzyme. For the sake of the mechanism completion the gluconic acid-2-ketogluconate step is also illustrated, however, this NADP dependent enzyme formation is strongly repressed by glucose (69, 76). This pathway was essentially assumed by the authors who conducted kinetic studies on gluconic acid formation (72-75).

ORIGINAL PAGE IS
OF POOR QUALITY

TABLE V
CHARACTERISTICS OF MICROBIOLOGICAL PRODUCTION OF D-GLUCONIC ACID
(AFTER PRESCOTT AND DUNN (69))

Microorganisms	Concentration of glucose, %	Temp., °C.	Method	Approximate length of fermentation	Principal products	Yield of principal products, %	Reference
<i>Acetobacter gluconicum</i>	5	30	Aeration	4 days	Gluconic acid	71.8-77.2	Porges, N., T. F. Clark, and E. A. Gastrock, <i>Iowa State Coll Jour. Sci.</i> , 16: 151 (1912).
<i>Penicillium italicum purpurogenum</i> var. <i>rubrosclerotium</i>	20-25	25	Surface	9 days	Gluconic acid	55-65	Herrick, H. T., and O. E. May: <i>Jour. Biol. Chem.</i> , 77: 185 (1928).
<i>P. chrysogenum</i>	20-25	30	Surface	8-10 days	Gluconic acid and calcium gluconate	60	Moyer, A. J., O. E. May, and H. T. Herrick: <i>Zentr. Bakt. Parasitenk., Abt. II.</i> , 95: 311 (1936).
<i>P. chrysogenum</i>	20	30	Submerged (pressure)	8 days	Gluconic acid and calcium gluconate	80-87	May, O. E., H. T. Herrick, A. J. Moyer, and P. A. Wells: <i>Ind. Eng. Chem.</i> , 26: 575 (1934).
<i>P. chrysogenum</i>	20	30	Submerged (pressure)	22 days	Gluconic acid and calcium gluconate	80	Wells, P. A., A. J. Moyer, J. J. Stubbs, H. T. Herrick, and O. E. May: <i>Ind. Eng. Chem.</i> , 29: 653 (1937).
<i>Aspergillus niger</i> NRRL 67	15.5	30	Submerged (pressure)	18 hr.	Gluconic acid and calcium gluconate	97.1*	Wells, P. A., A. J. Moyer, J. J. Stubbs, H. T. Herrick and O. E. May: <i>Ind. Eng. Chem.</i> , 29: 653 (1937).
<i>A. niger</i> NRRL 67	11.5	30	Submerged (pressure)	9 hr.	Gluconic acid and calcium gluconate	Porges, N., T. F. Clark, and E. A. Gastrock: <i>Ind. Eng. Chem.</i> , 32: 107 (1940).
<i>A. niger</i> NRRL 3	24-30	33.0-34.4	Submerged (pressure)	Under 10 hr	Sodium gluconate		Blom, R. H., et al.: <i>Ind. Eng. Chem.</i> , 44: 435 (1952).

* Based on glucose consumed.

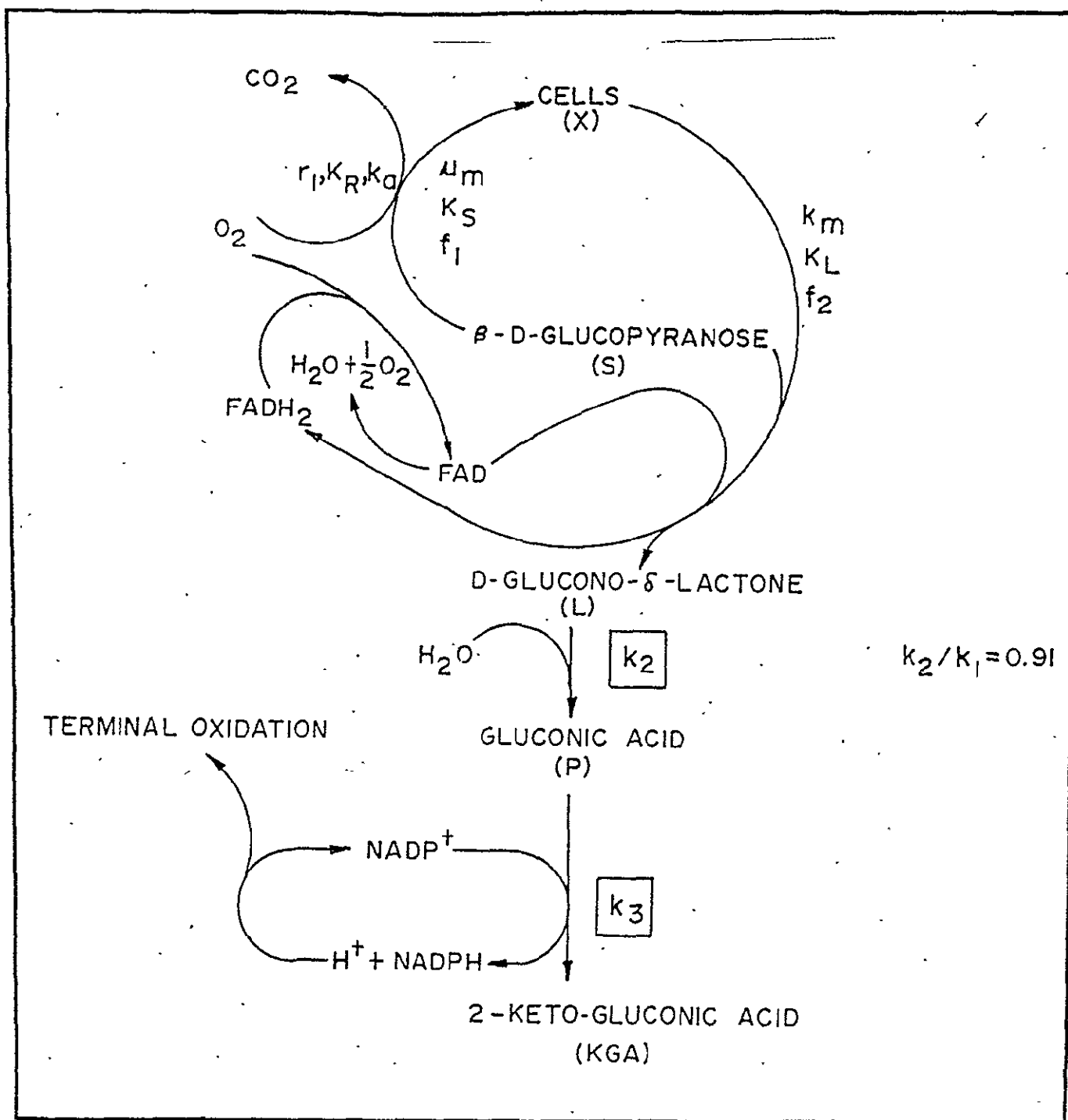

FIGURE 8
 PATHWAY OF D-GLUCONIC ACID BIOSYNTHESIS IN
 MICROBIAL CULTURES

2. COMPOSITION OF MEDIUM FOR P. OVALIS CULTURE

P. ovalis NRRL B-1486 strain can be cultured in aerated submerged culture having the medium composition (72,73) shown in Table VI. For comparison the table also contains the ingredients used for submerged, aerated culture of A. niger on industrial scale operations (63).

Characteristics of gluconic acid fermentation process - Figure 9 illustrates the changes in glucose, lactone intermedier and gluconic acid concentrations during the course of a P. ovalis batch culture (72). Data clearly indicate 1) accumulation of gluconolactone intermediate (L) and 2) appearance of unaccountable reducing sugar at the end of fermentation. HUMPHREY and REILLY (72) attributed these phenomena to 1) differences between the kinetic constants of the glucose-glucono-lactone (k_1) and the gluconolactone-gluconic acid steps (k_2), as well as to 2) appearance of enzyme activity resulting in kinetic conversion of the gluconic acid into 2-ketogluconic acid when the glucose concentration was lower than 10 G/L. The experiment was conducted at 30° C and at pH 5.8. At higher pH (pH - 6.0-7.0) value of k_2 increased, therefore no significant intermediate accumulation took place. On the other hand, the rate of gluconic acid formation was dependent on the intermediate concentration (Figure 10) (72). Although the authors defined the correlation with a straight line a detailed kinetic analysis of that data indicated that at higher intermediate concentrations the L-dP/dt correlation is more sensitive to environmental factors (pH, T, etc.) as can be demonstrated by a hysteresis curve drawn by us. Such intermediate-product formation rate correlations are common in enzyme systems symbolized as:

TABLE VI
COMPOSITION OF MEDIUM USED FOR GLUCONIC ACID
PRODUCER MICROBIAL CELL CULTIVATION

	<u>P. OVALIS</u> (72, 73)	<u>A. NIGER</u> (63)
	(g/L)	
GLUCOSE	50.00	240.00
(NH ₄) ₂ HPO ₄	0.00	0.42
KH ₂ PO ₄	1.00	0.19
MgSO ₄ ·7H ₂ O	1.00	0.16
AMMONIUM ACETATE	1.00	0.00
YEAST-EXTRACT	2.00	
CORN-STEEP LIQUEUR	0.00	3.69
UREA	0.00	0.10
H ₂ SO ₄ (pH adj.)	0.00	0.17
STERILIZATION	121°C, 30'	121°C, 30'
pH (Starting)	5.8	4.5

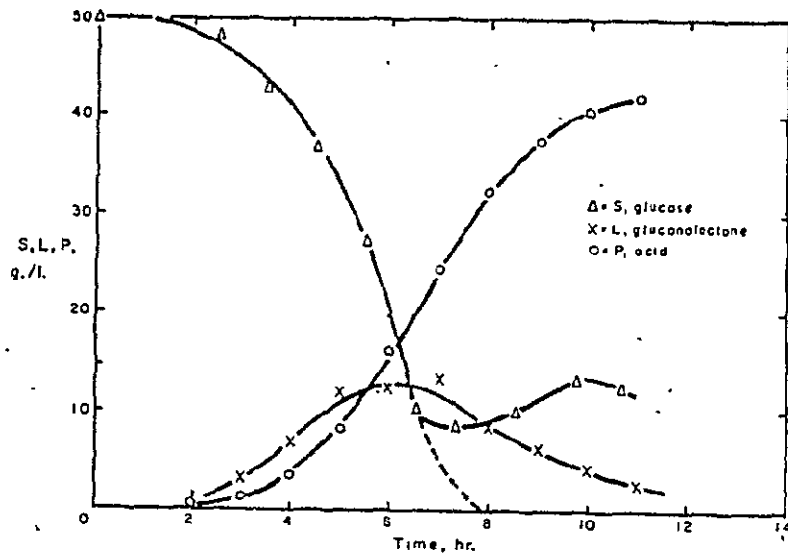

FIGURE 9.

TIME COURSE OF A D-GLUCONIC ACID
FERMENTATION
(72)

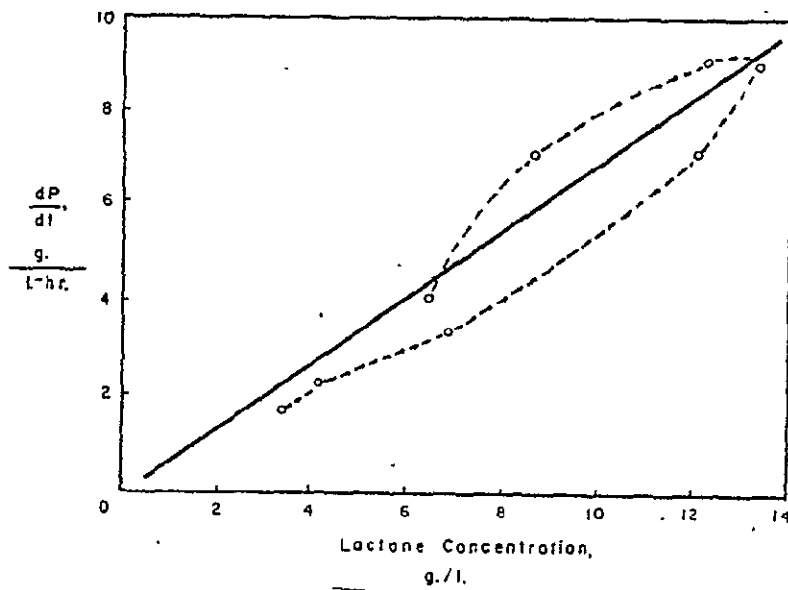
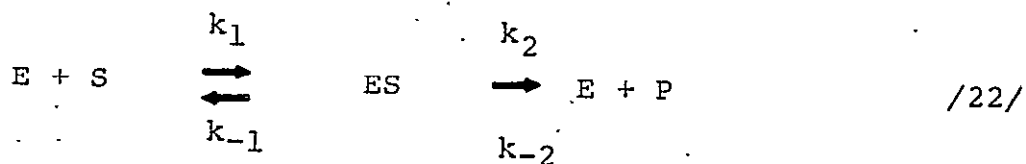

FIGURE 10,
DEPENDENCY OF PRODUCT (P) FORMATION RATE
ON THE INTERMEDIER (L) CONCENTRATION



where an intermediate (ES) is formed and environmental conditions (e.g. T, pH, etc.) offset the proportion between $k_{-1}/k_1 = k_{-2}/k_2$ (76). In other words, there is a significant difference between the P formation rates depending both on the absolute concentration and the formation rate of the intermediate. The hysteresis curve drawn in Figure 10 may also indicate other rate limiting steps in gluconic acid formation due to the transport of S, L and P through the cell wall.

Although the gluconic acid fermentation is one of the best understood processes, further 1-G based study is needed to design an adequate set of experiments which will be used for kinetic analysis of the biological process intended to prove or disprove the advantage of a microgravity environment on cellular activities.

HUMPHREY and REILLY were successful in following the formation rate of gluconic acid by pH measurement and control (72). In an other experiment TSAO and KEMPE successfully employed the reaction kinetics to determine oxygen transfer rate conditions in fermentors (77). This means that at least two sensors (pH and DO electrodes) directly inserted into the reaction chamber can provide signals which have correlation with the process kinetics. In addition, because of the presence of FAD (and possibly $NADP^+ \rightarrow NADPH$ system) changes in ORP may be used to follow the process kinetics.

Optimum environmental conditions for the P. ovalis gluconic acid fermentation were searched out in an off-line, computer based optimization (75).

Here a model was developed and the PONTYAGIN's continuous maximum principle was applied to the model to calculate the optimum temperature and pH profiles. Results indicate that the optimum temperature and pH for glucose-gluconic acid conversion are 34.2° C and pH 7.0, respectively. Data seem to correlate findings with regard to the increased k_2 if the pH is increased above 5.8.

5.3. RECOVERY OF GLUCONIC ACID BY ELECTROPHORESIS

As a general principle, electrophoresis is used to separate charged organic compounds (particularly amino acids, peptides and proteins) as well as inorganic ions.

Gluconic acid is recovered from chemical, biochemical, or microbiological reaction mixtures with conventional evaporation and crystallization techniques (e.g. 78-79). However, the present possibility to couple an experimental bioreactor - EFO apparatus for Space bioprocessing purposes makes it necessary to evaluate the possibilities of electrophoretic recovery of GA from reaction mixtures. In this case, the coordinated function of the two systems can be readily tested during the kinetic experimental phase of the project.

5.3.1. IONOPHORESIS OF GLUCONIC ACID

During the determination of degradation components of irradiated D-glucose, ionophoresis was used for separation of the compounds (29). Also, FOSTER and VARDHEIM (32) used ionoforetic techniques to analyze the components in a Br-H₂SO₄ reaction mixture. The two experimental conditions are compiled in Table VII. According to the reports, D-gluconic acid could be isolated and detected among various compounds

TABLE VII
EXPERIMENTAL CONDITIONS FOR D-GLUCONIC ACID
IONOPHORESIS

CONDITIONS	GRANT/WARD (29)	FOSTER/VARDHEIM (32)
TYPE OF OPERATION	PAPER IONOPHORESIS	PAPER IONOPHORESIS
MEDIUM USED	WHATMAN PAPER	(51x13 cm) WHATMAN No.3
QUANTITY OF GA (or liquid)	-	2.0 ml
BUFFER	0.2M BORATE (pH 10)	GLYCINE (pH 11)
POTENTIAL	-	1,000 V
TIME LENGTH	-	1.5 HRS.
REAGENT	SILVER NITRATE/NaOH	SILVER-NITRATE/NaOH (a)
ELUTION	WATER	WATER (Distilled)
TITRATION	-	PERIODATE (b).

(a) TREVELYAN et al, Nature 166, 444 (1950)

(b) JACKSON, Org. Reactions 2, 341 (1944)

including methyl-D-glucopyranoside, D-glucose, D-glucuronic acid.

1. It is noted that implementation of both techniques required neutralization of the reaction mixture before introducing it onto the paper. Reagent for neutralization is not reported in any case.
2. Inophoretic separation of gluconic acid makes it possible to test EFO based recovery equipment in conjunction with the biosynthesis apparatus, and this procedure will serve the purpose of "tuning" the function of biosynthesis-recovery subsystems as well as experimentally testing ordinated function of the bioprocessing apparatus with its auxiliary equipment.

6. BIOPROCESSING OF HORMONES

6.1. GENERAL COMMENTS

According to WHITE et al (80) hormones are regulators that influence the velocity of cellular transformations. Among their main characteristics the following are worthwhile noting:

1. Many hormones are essential for basic life functions. Their absence or excess presence may cause serious diseases (81). In addition, most current investigations reveal that certain hormones can perform extrahormonal functions altering mental states and behaviour. E.g. MSH and ACTH were experimentally found to improve memory, reduce anxiety (82).
 2. Unlike enzymes, hormones do not perform biochemical reactions, just regulate them. For instance, insulin regulates the glucose level in bloodplasma, via facilitating glucose transport through the cell wall, but does not break down or biosynthesize glucose (73).
-

-
3. The amount of a hormone necessary to implement its action is relatively low. For example, the adrenaline content in normal human blood is 0.1 $\mu\text{g/ml}$ plasma (83), the growth hormone (GH) is in a 1-53 μg concentration per one ml plasma to exercise its normal regulatory activity (83,128).
 4. Hormonal function is implemented via active intermediates ("metabolic amplifiers"). For instance, ACTH which regulates the activity of adrenal cortex, forms a reactive intermediate with cAMP and thus activates (among others) adenylyl cyclase, phosphorylase, b and cholesterol 20-hydroxylase enzymes in the adrenal cortex cells.
 5. Hormones are biosynthesized by specific endocrine organs. For instance, insulin is biosynthesized by the β -cells of the islets of the pancreas. One of insulin's antagonists, the glucagon is biosynthesized by the α -cells located in the same tissue of the pancreas. In some cases the hormone is biosynthesized in an organ, transferred for storage into an other organ which - upon regulatory command - releases the hormone. For example, vasopressin (a hormone influencing blood pressure) is made in the hypothalamus but stored in the posterior lobe of the pituitary gland. (83).
 6. Depending on their chemical composition the hormones are categorized as:
 - steroid hormones,
 - amino acid derived hormones, as well as peptide and protein hormones.

Table VIII presents the most important hormones produced by the endocrine glands of some vertebrates (84). The list indicates the release site of the hormone, its major effect on cellular

Hormone	Abbreviation	Gland Producing the Hormone	Effect
Steroid hormones			
Corticosteroids	—	Adrenal cortex	Mineral balance. Na^+ retention Metabolism: Gluconeogenesis
Progesterone	—	Ovary (corpus luteum)	Proliferation of the uterine mucosa (secretory phase)
Estradiol	—	Ovary (follicles)	Proliferation of the uterine mucosa (estrus).
Testosterone	—	Testes (interstitial cells)	Maintenance of the accessory glands of the genital tract and secondary sex characteristics
Amino acid-derived hormones			
Thyroxine	Thx, T-4	Thyroid gland	Increase of basal metabolic rate; development
Epinephrine (adrenalin)	—	Adrenal medulla	Glycogen breakdown
Melatonin	—	Pineal gland	Contraction of melanophores
Peptide and protein hormones			
Relaxin	—	Ovary	Relaxation of pelvic ligaments during pregnancy
Parathyroid hormone (parathormone)	—	Parathyroid gland	Ca^{++} mobilization
Insulin	—	Pancreas	Lowering of blood sugar level
Glucagon	—	Pancreas	Raising of blood sugar level
Oxytocin	—	Pituitary gland, posterior lobe	Contraction of uterus
Vasopressin	—	Pituitary gland, posterior lobe	Antidiuretic action
Melanotropin (melanocyte-stimulating hormone; intermedin)	MSH	Pituitary gland, middle lobe	Dilation of melanophores
Somatotropin (growth hormone)	STH	Pituitary gland, anterior lobe	Growth and metabolism
Corticotropin (adrenocorticotrophic hormone)	ACTH	Pituitary gland, anterior lobe	Stimulation of the adrenal cortex
Thyrotropin	TSH	Pituitary gland, anterior lobe	Stimulation of thyroid gland
Follicle-stimulating hormone	FSH	Pituitary gland, anterior lobe	Stimulation of production of estradiol in ovary
Luteinizing hormone (interstitial cell-stimulating hormone)	LH (or ICSH)	Pituitary gland, anterior lobe	Stimulation of production of sex hormones
Luteo-mammotropic hormone (luteotropin, prolactin)	LTH (LMTH)	Pituitary gland, anterior lobe	Stimulation of mammary gland and of corpora lutea
Gonadotropin (Chorionic gonadotropin)	(HCG)	Placenta	Similar to LH

TABLE VIII

SOME IMPORTANT HORMONES OBTAINED FROM VERTEBRATES

(AFTER KARLSON (84))

transformation and the generally used abbreviation of the hormone. It is noted that in many cases synonyms are used. The reader should consult KUTSKY (83) to find the synonyms of a particular hormone.

7. Hormones interact with other compounds of physiological importance which results in a) enhanced activity (synergism), b) decrease in effect (antagonism), c) new, specific effect which is different from the hormone's original effect, d) hormonal change in the production rate of hormones. The interacting compounds are predominantly other hormones or vitamins. Examples of interactions are depicted in Figures 22, 23, 24.
8. In addition to these direct hormonal effects on the metabolism, certain hormones stimulate or restrict the release of other hormones. Some non-detailed interactive schemes are given in Figures 22, 23, 24. For more detailed information on interactions, the reader should consult KUTSKY (83). It is also noted, that modern endocrinology reveals more and more interactions or direct effects, therefore, this part of the report needs updating from time to time.
9. Depending on their chemical composition, hormones can be chemically synthesized (e.g. thyroxine, ACTH), microbiologically modified (e.g. some steroid hormones) or extracted from the producer or storage organs (e.g. LH (gonadotropin II)). In some cases it was possible to maintain animal cells in vitro which had the capability to produce hormones for an extended period of time (84). Peptide and protein hormones can be recovered and purified by electrophoresis (83).

Assessing the aforementioned features, it is apparent that:

-
- 1) Hormones are of utmost importance from both scientific research and therapeutical points of view.
 - 2) Despite the fact that some (mostly steroid type) hormones can be mass produced, many hormones can not be manufactured in quantities sufficient enough to perform adequate research or use them as therapeutic agents.
 - 3) Because hormones act in relatively small quantities (c.f. points #3 and #4) even a small bioprocessing system may have the capability to produce certain selected hormones for medical research and, later, for pharmaceutical application.
 - 4) Some hormones of scientific and medical importance were successfully biosynthesized in vitro, using animal tissues or cells. The potentially advantageous effect of the microgravity environment may be utilized to enhance the growth and metabolic activity of cell lines and biosynthesize hormones with a higher rate. In addition, recovery of these compounds in ultrapure form can be accomplished with the application of EFO also performed in microgravity environment. Because of this assessment, in the following chapters the possibility of producing hormones by animal cell cultures will be discussed.

6.2. IN VITRO CULTURING OF ANIMAL CELLS

Dealing with the possibility of using animal cells for biosynthesis of hormones, it is necessary to give a brief outline on the state-of-the-art for propagation of such cells under artificial conditions. The reader interested in more detail can obtain further information from KRUSE and PATTERSON's most recent work (87).

6.2.1. GROWTH CHARACTERISTICS OF ANIMAL CELLS

Table IX presents a comparison on the main characteristics of microbial and animal cells. These features are important in the design of vessels and control instrumentation for animal cell cultures. Although the table is self-explanatory, attention is drawn to the fact that 1) the animal cells regulatory mechanism is less flexible than that of microbial cells, 2) the animal cells have decreased capability to adapt to their environment, 3) they are more sensitive to their predators and 4) changes in their genetic structure is, at least to this date, irreversible:

Figure 11 shows the differences in the main environmental conditions necessary to successfully propagate microbial and animal cells.

The first important observation is the relatively narrow operational range of environmental variables. This is especially valid for the temperature, the optimum for vertebrate cells is 37°C with a minimum 31°C and maximum 39°C , and pH range between 6.8-7.8 extremities, with a pH 7.0-7.5 optimum plateau.

The effect of O_2 also shows characteristics specific to eucaryotic cells. The available data indicate that 1) there is an optimum in the effect of pO_2 on cell growth, 2) the optimum pO_2 and its plateau varies from one cell-type to another, however, the average optimum pO_2 is around 100 mm Hg. This finding confirms the fact that the O_2 content in the human arterial plasma is in equilibrium with 95 mmHg pO_2 (12% O_2) (87), and 3) inhibitory pO_2 also varies depending on cell-lines, however, there is reportedly inhibition of growth as low as 250 mmHg pO_2 (33% O_2).

Carbon dioxide was found essential for protein synthesis and growth. Generally a CO_2 -air mixture is

	MICROBIAL CELL	ANIMAL CELL
SIZE	$\approx 1 \mu$	10-100 μ
METABOLISM	INDIVIDUAL REGULATION FLEXIBLE BIOCONVERSION	INDIVIDUAL + HORMONAL REGULATION LESS FLEXIBLE METABOLIC PATHWAYS
DOUBLING TIME	MINUTES	HOURS
ENVIRONMENT	SELF-RESPONSE TO THE CHANGES	DECREASED CAPABILITY TO ADAPT TO THE CHANGES
	COMPETITIVNESS	SENSITIVITY TO PREDATORS (VIRUS)
GENETICS	MUTATION $\alpha \rightleftharpoons \alpha_1$	DIPLOID \rightarrow HAPLOID CONVERSION

TABLE IX
COMPARISON ON THE MAIN CHARACTERISTICS
OF MICROBIAL AND ANIMAL CELLS

SOME ENVIRONMENTAL FACTORS INFLUENCE MICROBIAL AND ANIMAL CELLS

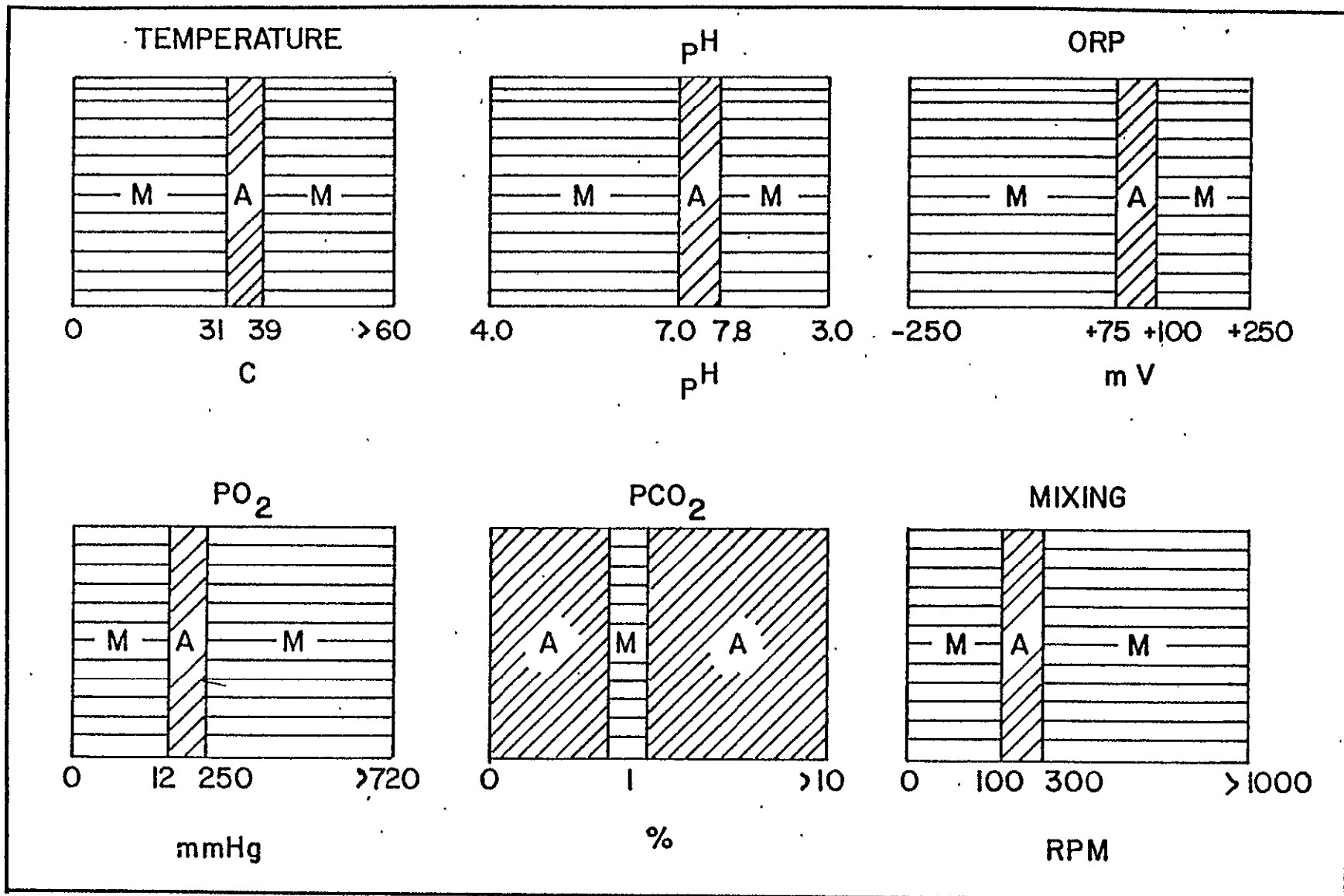

FIGURE 11.

COMPARISON BETWEEN ENVIRONMENTAL CONDITIONS FOR CULTURING MICROBIAL AND ANIMAL CELLS IN VITRO

introduced into the culture (95% air enriched with 5% CO₂). In addition to this, the preferred way to establish and maintain pH is the application of bicarbonate buffer and the addition of CO₂ gas into the culture liquid. According to the most recent information, CO₂ plays an important role in the cellular metabolism (88).

In the past few years, there has been considerable increase in the attention paid to the effect of oxidation-reduction potential (ORP) on the growth of eucaryotic cells (57). There were two important findings, namely, 1) the initial ORP of the culture medium defines the growth rate (hence the related enzyme activities) and the peak yield in cell mass, and 2) there is a defined ORP domain where the growth rate of the animal cells is at a maximum. For optimum growth of L-DR, L, and lymphoid cells, ORP = +75 - +100 mV range was found necessary.

ORP can be manipulated in many ways: by introduction of H₂, expelling O₂ by N₂, or addition of compounds with oxidative-reductive capability (e.g. cysteine, indophenol, ascorbic acid).

Complex physical stresses are reportedly damaging to eucaryotic cells. Two effects were described, namely the effect of shear stress (HeLa, mouse L-929 cells: 89, 90, resp.), and the change in surface activity because of air bubble introduction (91).

A different chapter could be the question of sterility of the animal cell cultures. Here, the most important factors are the filtration of heat labile culture components (e.g. serum) and the filtration of gases to avoid Mycoplasma and virus contamination (92). Presence of contaminant(s) can upset the metabolic profile of the culture resulting in difficulties during the recovery and purification.

Also, an extensive study is required to define the nutritional effect (culture medium) conditions. Particularly, the interactive effects of inducers and activators on the hormone biosynthesis must be investigated in detail in the future.

6.2.2. EQUIPMENT FOR CULTURING ANIMAL CELLS IN VITRO

There is a wide variety of culture techniques and apparatus for culturing animal cells (86) Figure 12). This is explainable by the technical problems in establishing and maintaining suitable environmental conditions for cells isolated from different bodies, organs, and tissues. The main problem in culturing animal cells is the fact that, in most cases, the prerequisite of cell proliferation is the attachment to a surface, (anchorage dependency, STOKER et al (93)).

Although several reports indicate (90, 94) the usefulness of solid surface based culture of animal cells, there are two basic problems related to this methodology, namely, 1) the growth takes place only in two dimensions (cm^2) and 2) the development of the cells is frequently limited by an unfavorable pH value with depletion of O_2 or nutrient. There have been attempts to solve these problems (multi-surface propagators and perfusion cultures (90, 94)) (Figure 13) nevertheless, the dimensional problem still remained the controlling factor for large-scale operation.

Another approach to maintain tissue cultures on solid surface was the utilization of artificial capillaries to support growth of cells with anchorage dependency (95). Basic concept of the operation is shown in Figure 14. The apparatus consists of ultrafiltration capillaries (marked 1-4 on the

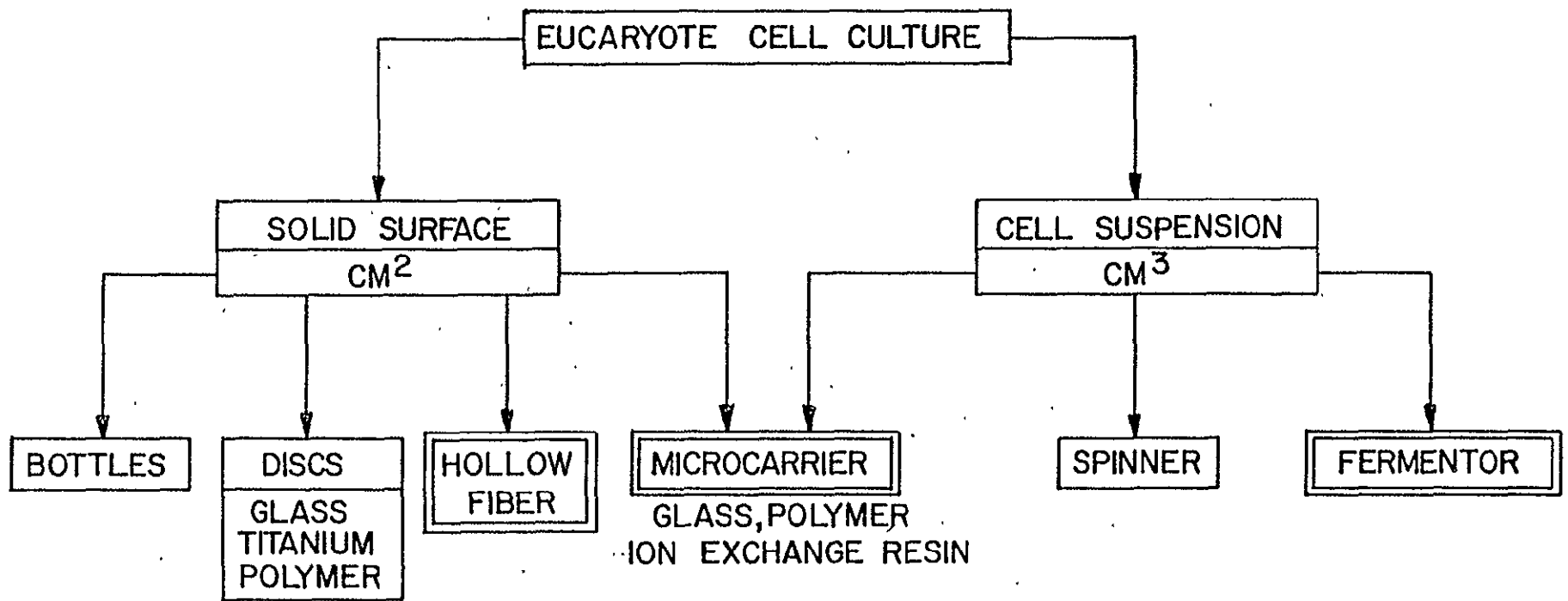
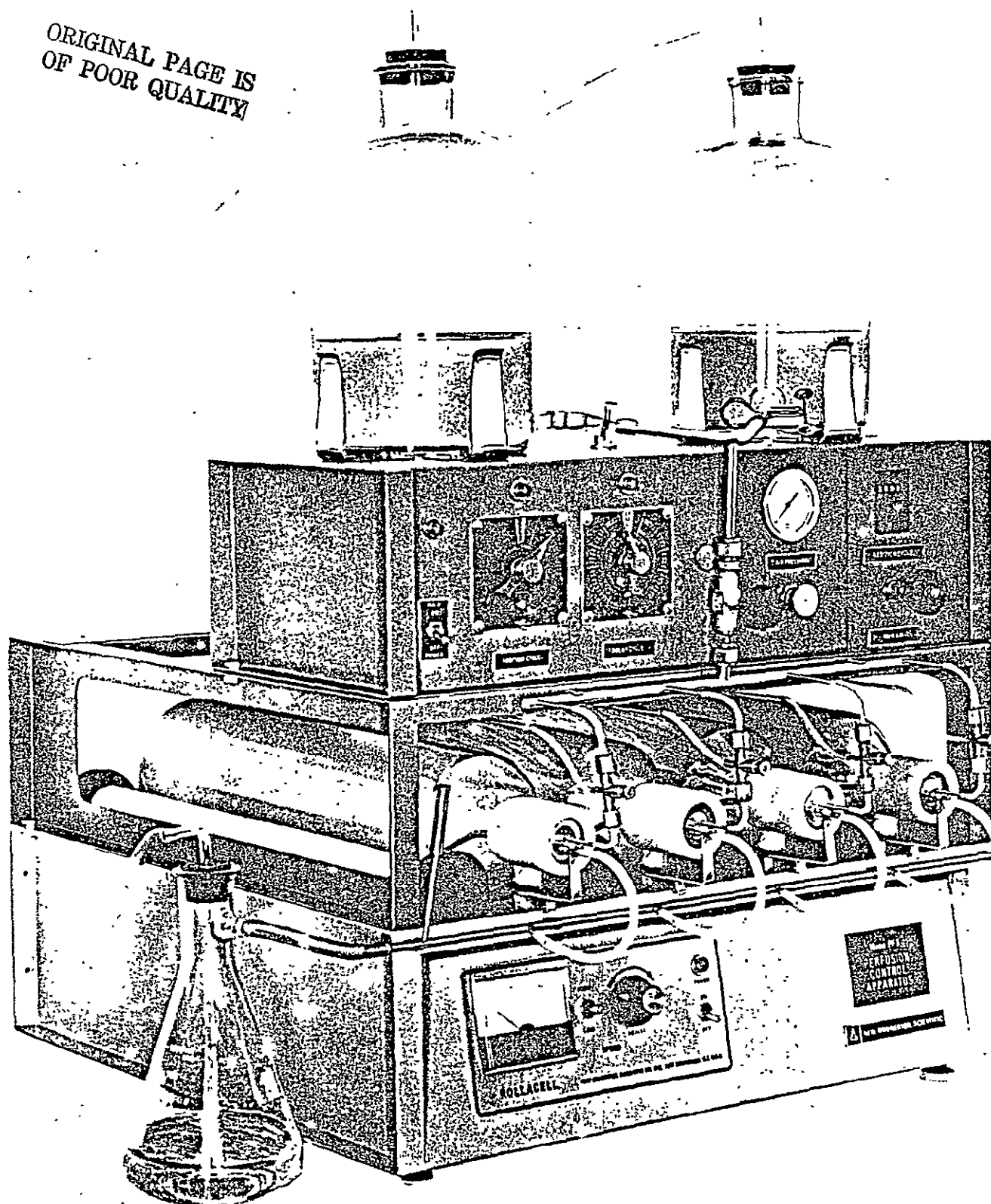

FIGURE 12

APPARATUS AND TECHNIQUES FOR CULTURING ANIMAL CELLS

ORIGINAL PAGE IS
OF POOR QUALITY



#R16 Perfusion Control Apparatus, Model PF-4
integrated with Model RC-42 Rollacell
Tissue Culture Apparatus containing four
Roller Bottles.

FIGURE 13

BASIC EQUIPMENT FOR CULTURING ANIMAL CELLS IN VITRO

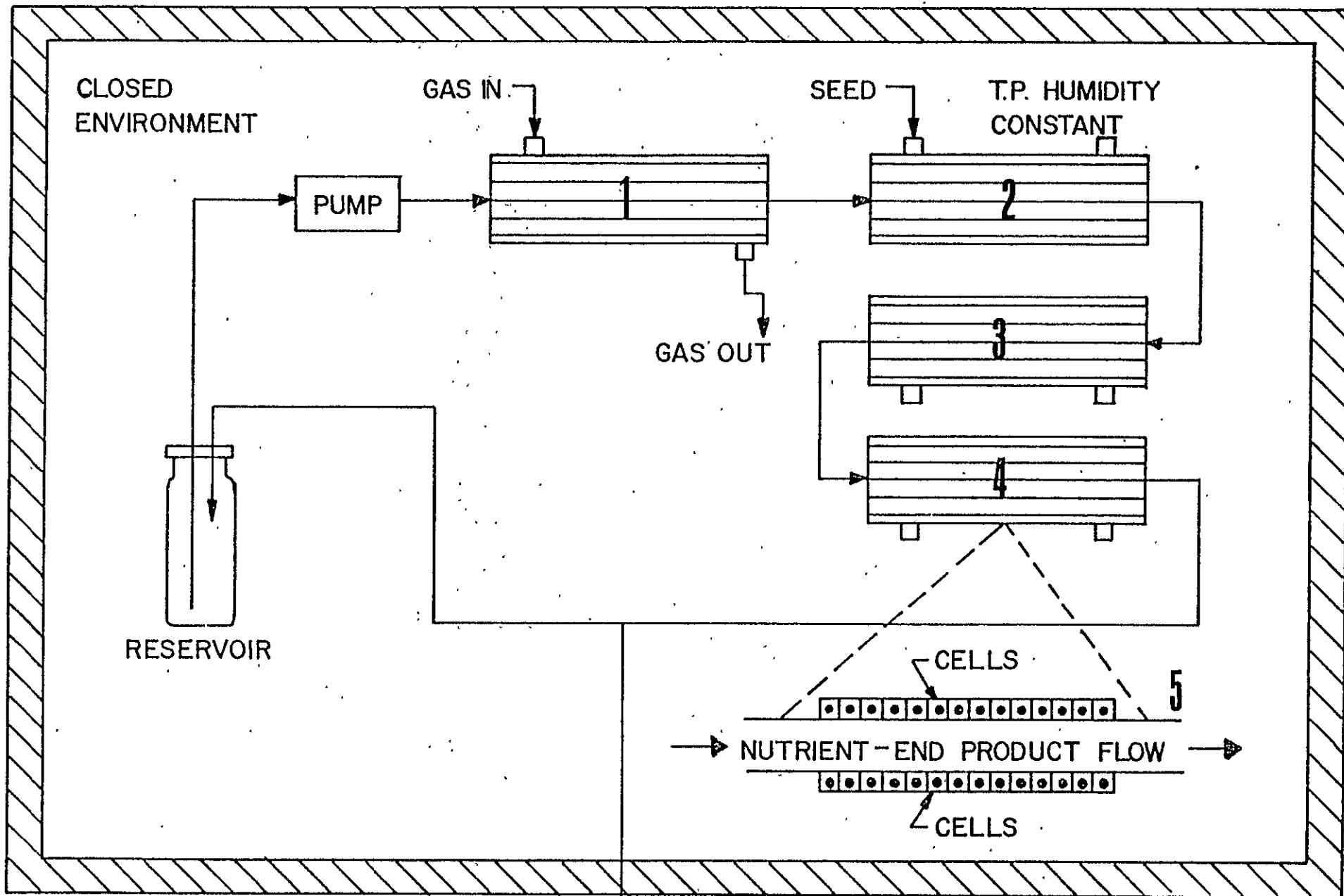

FIGURE 14

DESIGN CONCEPT AND OPERATION OF
 MICROCAPILLARY ANIMAL CELL CULTURE
 SYSTEM

RESERVOIR

drawing). Cells are growing on the outer surface of the capillaries (see 5 on the drawing) while the nutrient is circulated through the capillaries by a pump. This nutrient can be enriched with gases (O_2) in a gas permeable capillary (marked 1 on the drawing). Nutrients essential for the cell growth as well as metabolic products from the cells are diffusing through the capillaries. Type and pore size of the capillary controls the diffusion of molecules of various molecular weight. In fact, the function of capillaries is analogous to the blood vessels in transportation of nutrients to and metabolic products from the cells. The gas exchange capillary is analogous to alveoli of the lung. This technique made it possible to grow human choriocarcinoma (JEG-7) cells which reached 2.17×10^8 cell density in 3 cm^3 ! These cells produced human chorionic gonadotropin hormone (HCG) (c.f. 6.3.2.) for about 28 days. The hormone diffused through the capillary and could be recovered from the spent culture medium.

Since there are similarities between the growth of microbial and animal cells, there is an interest in growing mammalian cells in suspension culture using the knowledge accumulated by cultivating microbes in submerged culture. The major advantage of this method is the introduction of the third dimension (cm^3) and the relatively easy way to maintain environmental control for optimum growth. The major difficulty, which still exists to a certain degree, is that not all cell types show an ability to grow in suspension culture (c.f. anchorage dependent).

Basic design concepts of mammalian suspension culture vessels are shown in Figures 15 and 16. Figure 15 presents a spinner culture vessel which serves as perfusion apparatus for cell suspension cultures (96). The cylindrical filter spins at a rate of

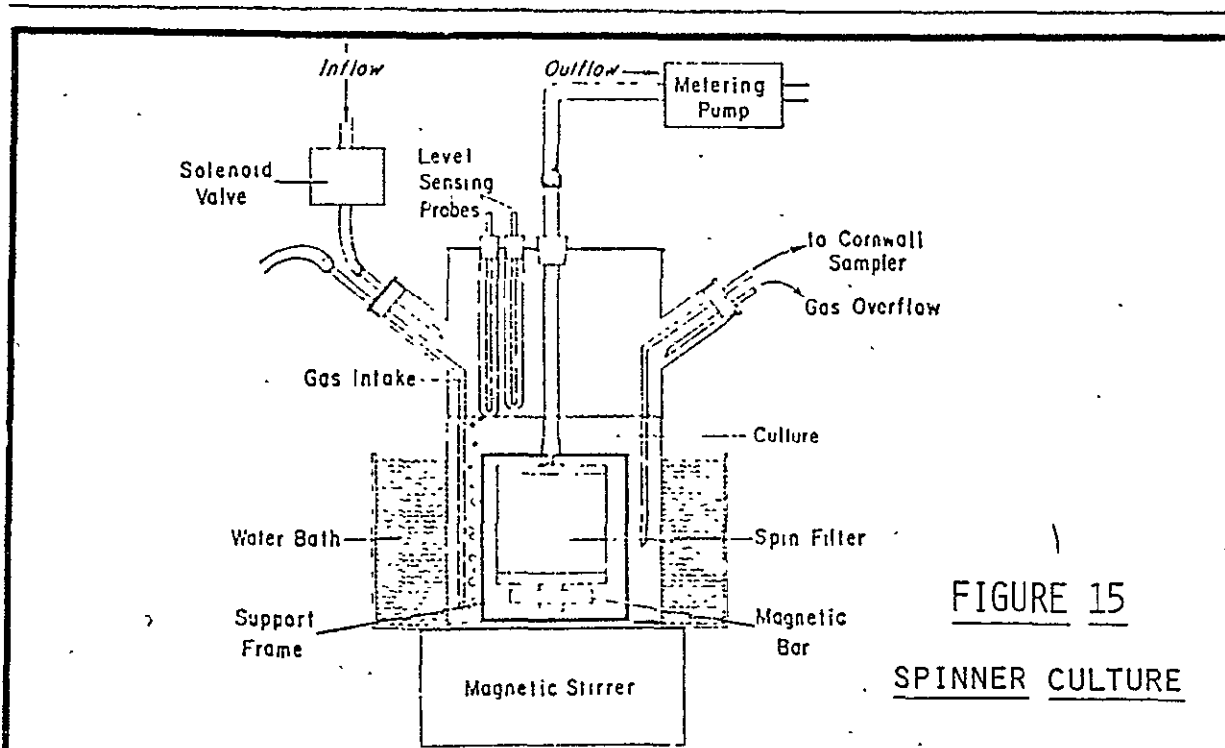

FIGURE 15

SPINNER CULTURE

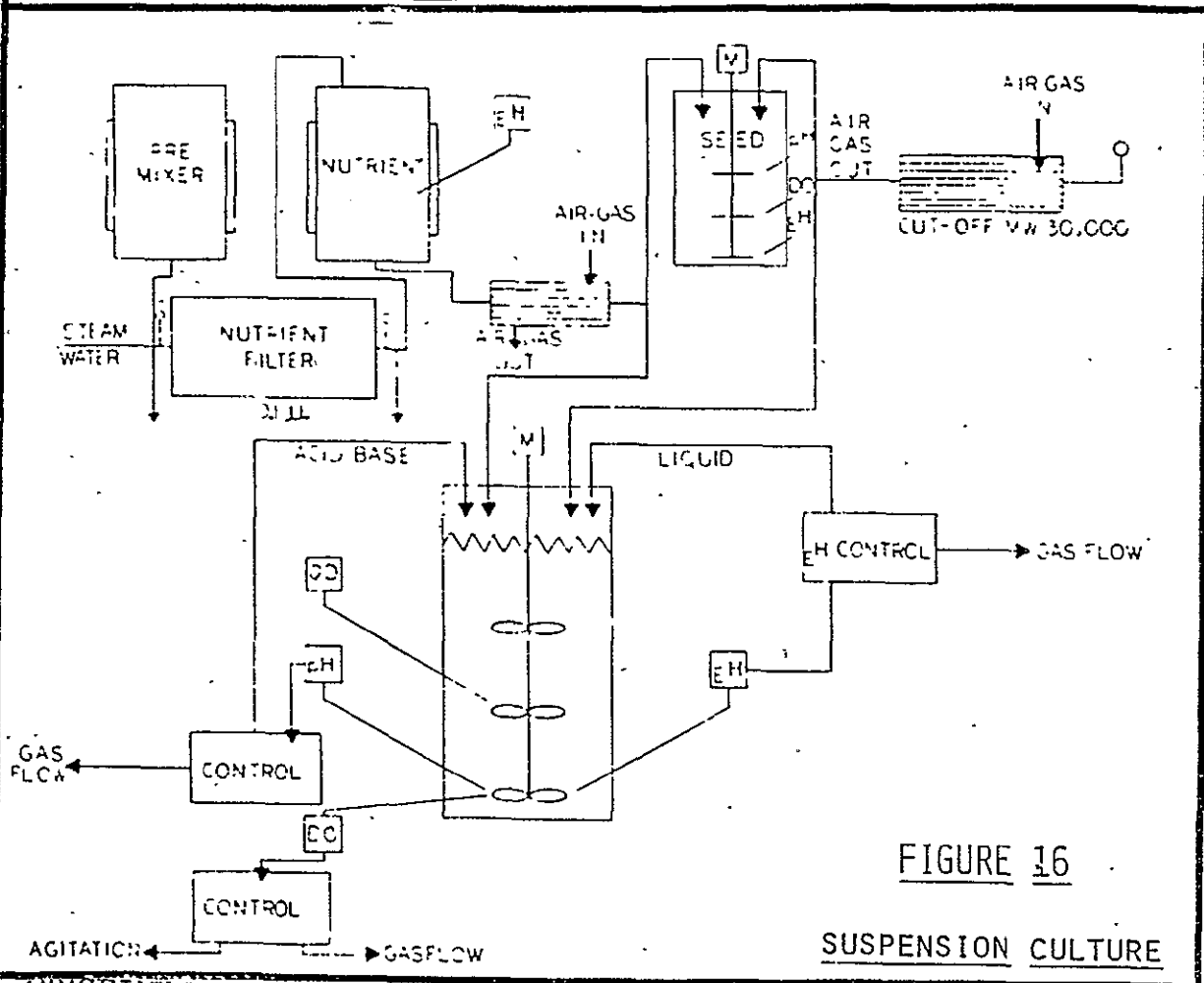

FIGURE 16

SUSPENSION CULTURE

ORIGINAL PAGE IS
OF POOR QUALITY

C-2

300 r.p.m. and allows culture medium to be aspirated out of the culture as fresh medium is perfused into the vessel, without clogging of the filter by the cells. At perfusion rates of the order of 75-100 ml/hr cell densities approaching 10^8 cells/ml have been achieved (26).

An other suspension culture system (97) contains peripheral equipment including medium mixing, sterilization subsystem, seed culture vessel and cell propagator, control elements for maintaining the optimum environmental conditions during the cell culture. In both cases the cells are kept in suspension by mild agitation of the culture liquid.

Suspension culture systems were found scaleable up to 3,000 liter liquid volume (90). One system including all of the elements similar to one depicted in Figure 16 was designed in cooperation with ACTON and LYNN and is operating in a semi-continuous mode at University of Alabama at Birmingham, Ala. since 1975 (98), producing about 10^{12} lymphoblastoid cells per week in a 500 liter culture liquid.

As it was mentioned, not all animal cell lines have the capability to grow in suspension. A technique developed by VanWEZEL and his coworkers (99) tried to overcome this difficulty using SEPHADEX or DEAE cellulose beads as microcarriers. Cells with anchorage dependency are growing on the microcarrier surface while the microcarrier beads are kept in suspension by agitating the aerated culture medium.

Based on the experimental data, Table X compiles the maximum animal cell numbers achieved by various culture techniques. Here the initial (C_0) and final (C_t) numbers are given in a unit volume (ml). It is noted that 1) the initial cell number to start an animal cell culture of any form must be between 1×10^5 - 1×10^6 cells/ml and 2) maximum

TABLE X
COMPARISON OF ANIMAL CELL YIELDS OBTAINED
WITH DIFFERENT CELL CULTURE TECHNIQUES

CELL TYPE	CULTURE TECHNIQUE	CELL CONCENTRATION (1)
PRIMARY MONKEY KIDNEY	MONOLAYER	$C_0 = 1 \times 10^5$ $C_T = 4.2 \times 10^5$
WI-38, VA 13A	MULTILAYER, PERFUSION	$C_0 = 2.04 \times 10^5$ $C_T = 1.01 \times 10^7$
BHK-21	SUSPENSION	$C_0 = 0.5 \times 10^6$ $C_T = 7 \times 10^6$
BHK-21	MICROCARRIER SUSPENSION	$C_0 = 1 \times 10^5$ $C_T = 1.6 \times 10^6$
CHORIOCARCINOMA JEG-7	HOLLOW-FIBER	$C_0 = 1 \times 10^6$ $C_T = 7.23 \times 10^7$
L1210 LEUKEMIA	SPINNER-CULTURE	$C_0 = 8 \times 10^5$ $C_T = 9 \times 10^7$

(1) C_0 = INITIAL CELL NUMBER AT THE TIME OF SEEDING (CELL/ML)

C_T = FINAL CELL CONCENTRATION (CELL/ML)

cell number of $1 - 9 \times 10^7$ cells/ml was achievable using various culturing techniques. Microcapillary (hollow-fiber) and spin filter suspension culture techniques were found to yield the maximum cell number (95, 100).

The possibility to achieve three dimensional cell growth in microgravity conditions was discussed by BRADVAROVA et al (101). Apparently, cells with anchorage dependency can be grown in suspended form in a soft (0.035%) agar. Gravity adversely influenced the growth rate as well as the physiological conditions of the cells. These findings were corroborated exposing Staphylococcus cells to various gravity conditions (102). On the basis of these preliminary findings it is expected that in microgravity conditions cell growth patterns will be also altered (103). The expected direction of change is toward the accelerated growth rate and/or the increased cell density (13, 104). This, in case of a growth related hormone biosynthesis (95), substantially enhances the hormone production rate.

6.3. PRODUCTION OF HORMONES BY ANIMAL CELLS

There is increasing evidence to suggest that many currently known mammalian hormones could be produced by in vitro culturing of animal organs or cells (105). In particular, some hormones have already been produced using animal cell cultures. These are listed in Table XI. Reviewing the literature and comparing this list with the one given in Table VIII, it appears that 1) so far, it was possible to produce at least 50 per cent of the essential hormones culturing animal cells in vitro, 2) in many cases the in vitro biosynthesis of hormones was accomplished using malignant cells which generally have the capability to be cultured in suspension,

TABLE XI

LIST OF HORMONES PRODUCED BY MAMMALIAN CELL CULTURES

HORMONE	CELL TYPE (ORIGIN)	TECHNIQUE (CULTURE)	REFERENCE
<u>STEROIDS</u>			
4-3-KETOSTEROIDS	CLONAL TESTICULAR LEYDIG CELLS		(106)
HYDROEPIANDOSTERONE	EMBRIONIC GONADAL (CHICKEN)	TISSUE	(107)
TESTOSTERONE	EMBRIONIC GONADAL (CHICK, MOUSE)	TISSUE	(107)
ANDROSTENEDIONE	EMBRIONIC GONADAL	TISSUE	(108)
ESTRONE	EMBRIONIC GONADAL	TISSUE	(108)
ESTRADIOL	EMBRIONIC GONADAL	TISSUE	(108)
<u>AMINO ACID DERIVED</u>			
THYROXINE (T ₄)	NONMALIGNANT THYROID	TISSUE	(109)
EPINEPHRINE	ADRENAL CORTEX TUMOR		(111)
NOREPINEPHRINE			

TABLE XI
(CONTINUED)

HORMONE	CELL TYPE (ORIGIN)	TECHNIQUE (CULTURE)	REFERENCE
<u>PEPTIDES AND PROTEINS</u>			
PARATHYROID	PARATHROID ADENOMA		(85)
INSULIN	NORMAL PANCREATIC ISLETS β -CELL ADENOCARCINOMA	SUBMERGED	(113)
GLUCAGON	NORMAL PANCREATIC ISLETS	SUBMERGED	(113)
GH	PITUITARY	SUBMERGED	(109)
ACTH	PITUITARY	SUBMERGED	(106)
HCG	TROPHOBLASTIC (BEWO) (PERMANENT) HUMAN CHORIOCARCINOMA JEG-7 (PERMANENT)	TISSUE MICROCAPILLARY	(114, 95)
CALCITONIN	HUMAN MEDULLARY CARCINOMA OF THYROID	TISSUE	(85, 115)
PROLACTIN	PITUITARY		(110)
THYROGLOBULIN (PROHORMONE)	NONMALIGNANT THYROID, MEDULLARY CARCINOMA OF THYROID	TISSUE	(109, 112)

3) some permanent cell-lines could be established (85, 121) but even in the case of loss of the cell-line; primary cell cultures could be obtained from fresh tissues (86, 119, 121).

In the following sections two examples are given demonstrating the possibility for production of hormones of medical importance using in vitro mammalian cell cultures. The hormones are: 1) Growth Hormone (GH) and 2) Human Chorionic Gonadotropin (HCG).

6.3.1. GROWTH HORMONE PRODUCTION IN VITRO

Extensive studies were conducted since 1965 to produce GH by various techniques (116). A basic cell line was successfully developed (GH₃) originating from a rat pituitary tumor. Cells could be cloned (at least twelve serial clones of GH₃ were obtained, each clone derived from a single cell of the preceding clone) and had the capability to grow in monolayer tissue and in suspension culture.

Culture requires HAM's F-110 Medium (available from Microbiological Associates, 5221 River Road, Bethesda, Md. 20016, 1976 Catalog No. 12-618) supplemented with 15% horse serum and 25% fetal calf serum. Growth temperature is 37° C, in a humidified atmosphere containing 5% CO₂ + 95% air.

The cells simultaneously produce GH and prolactin. Based on microcomplement fixation assay (117) both hormones can be measured. No correlation has so far been investigated between the production of hormones and other process variables (e.g. changes in pH, ORP, oxygen consumption rate) as it was accomplished in the case of microbiological cultures (21). Figure 17 presents the GH production rates expressed as µg hormone produced per mg cell protein per 24 hours (118). Three important factors are worth noting:

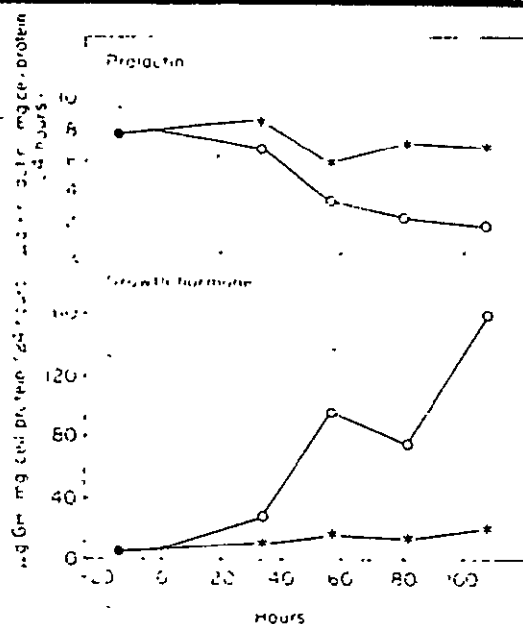

FIGURE 17.

EFFECT OF HYDROCORTISONE (HC) ON PROLACTIN AND GH PRODUCTION RATES BY GH3 CELLS

(O-O HC TREATED CULTURE; *- * CONTROL)
(118)

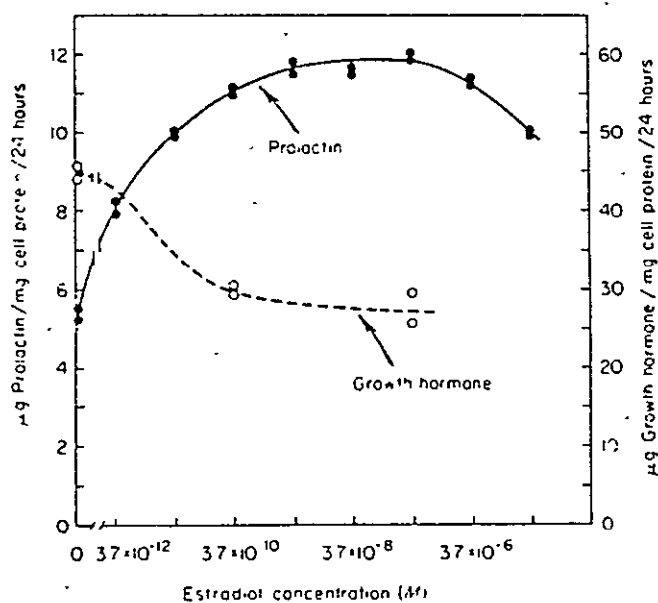

FIGURE 18.

EFFECT OF 17β -ESTRADIOL ON PROLACTIN AND GH PRODUCTION BY GH3 CELLS
(119)

1) The hormone production rate changes with elapsed culture time; whereas the production of GH increases, the prolactin production decreases, 2) there is a definite regulating effect of hydrocortisone in the production of hormones. This is in accordance with observations on the interactive effect of hormones both on production and action levels (c.f. p. 72). Such regulatory effect is observable using 17β -estradiol to increase prolactin production at the expense of GH (Figure 18), 3) regulatory effect of other hormones takes place at low level (e.g. 5×10^{-8} - 3×10^{-6} M in case of hydrocortisone, 10^{-9} M in case of 17β -estradiol). TASHJIAN's group reports a lag period of 24-36 hours between the addition of the regulator and its effect.

In another series of experiments, human pituitary cells from various origins were cultured. The culture conditions were essentially the same as in the case of GH₃ cells. Hormone production was maintained for 60-405 days. In one reported case, TASHJIAN's group was able to establish clones of human pituitary adenoma cells which actively secreted human GH. The hormone produced this way was immunologically authentic with human growth hormone (85).

These data indicate a high probability of cloning pituitary cells for in vitro production of hormones, particularly GH which is currently among the rarest hormones. It was also noted recently that it was possible to culture calf anterior pituitary cells in microcarrier suspension culture with a result of increased number of active cells (5×10^6 cells/ml (120)).

6.3.2. HUMAN CHORIONIC GONADOTROPIN HORMONE (HCG) PRODUCTION IN VITRO

Perhaps the most successful attempt to produce hormones

by means of in vitro animal cell cultures is the biosynthesis of the human chorionic gonadotropin hormone (HCG). This hormone is comparable in biological action to the pituitary luteinizing hormone (LH).

According to PATTILLO (121) it was possible to explant trophoblastic tissue from a malignant placental tumor (choriocarcinoma) (114) and maintain it by means of serial transplantation in animals. Most recently four additional lines and clones were obtained (121) directly from patient biopsy without animal transplantation. Hormone production could be maintained for several weeks.

The best culture medium is composed of WAYMOUTH'S Medium (50%), GEY'S BSS (30%) (available from Microbiological Associates, Catalog No. (1976) 10-505) with phenol red, supplemented by 20% human umbilical cord serum. Antibiotics (penicillin: 100 IU% and streptomycin: 20 mg%) may be used to enhance the sterility conditions. Phenol red indicated some metabolic changes. This indicates that it is possible to find correlation between the cells metabolic activity and changes in environmental conditions (e.g. pH) which is essential to control of biological processes (21). The cells were cultured in multilayer form. HCG was produced together with progesterone and estrogen but the production rates varied depending on the type of culture medium. Maximum production rate was 1000 IU per 10^8 cells per 24 hours.

KNAZEK et al reported a technique to propagate choriocarcinoma (JEG-7) cells in a density which reached the one existing in normal tissues (95). The basic apparatus KNAZEK and his coworkers used is described in Section 6.2.2. (p. 80).

Figure 19 presents the apparatus (a); and the results (b) in terms of HCG production rate. In the experimental case HAM'S F-10 Medium was used (83.3%), with 13.5% horse serum, 3.2% fetal calf serum,

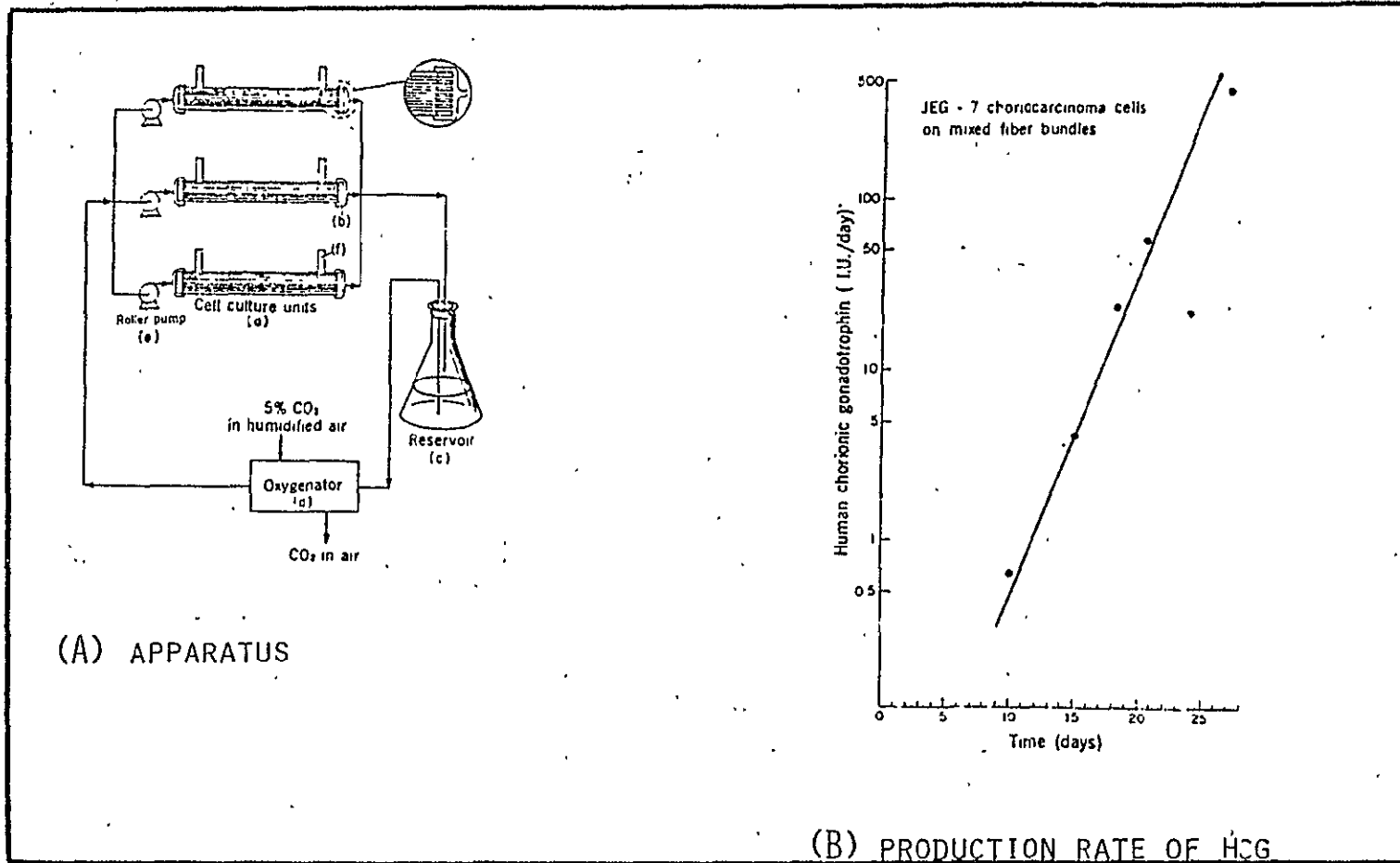

FIGURE 19

PRODUCTION OF HCG HORMONE WITH CHORIOCARCINOMA JEG-7 CELLS
GROWN IN A CAPILLARY PERFUSION APPARATUS
(AFTER KNAZEK ET AL (95))

5,000 IU% penicillin-G, 5 mg% streptomycin, 0.5% mg% insuline and 0.62 mg% cortisone acetate (pH 7.3 T = 37%). Culture liquid was circulated with a rate of 42 ml/hr through the capillaries. Continuous replacement of medium enhanced the transfer of nutrients to the cells and resulted in the removal of metabolic products.

After a lag period of 5-7 days the production rate increased with doubling in every 1.1-1.2 days. It is noted that the maximum production rate (500 IU HCG/day) was obtained from a culture which was equivalent to 2.17×10^8 cells in about 3 cm³ space. HCG production rate increased with the increase of culture medium circulation rate to 300 ml/min. Stimulative effect of various hormones on the production has not been experimentally tried yet.

6.4. RECOVERY OF HORMONES

Depending on their origin and chemical characteristics, hormones can be recovered by various techniques (83). Figure 20 describes four essential ways to obtain hormones. Sources of hormones are either 1) animal (organs, tissues or excretum), 2) animal tissue (suspension) cultures, 3) hormone raw materials (precursors) which can be converted either micro-biologically or by chemical synthesis. Roman numbers in the drawing indicate essentially analogous steps in the processes. Whatever are the raw materials and the production steps, the hormone in its "crude form" contains substances (as contamination) which must be removed by means of various recovery-purification techniques to obtain clinically useable products..

Table XII gives a list of some selected hormones of medical importance indicating their status in the commercial production, purity and the current source for production. It is noted, that despite the

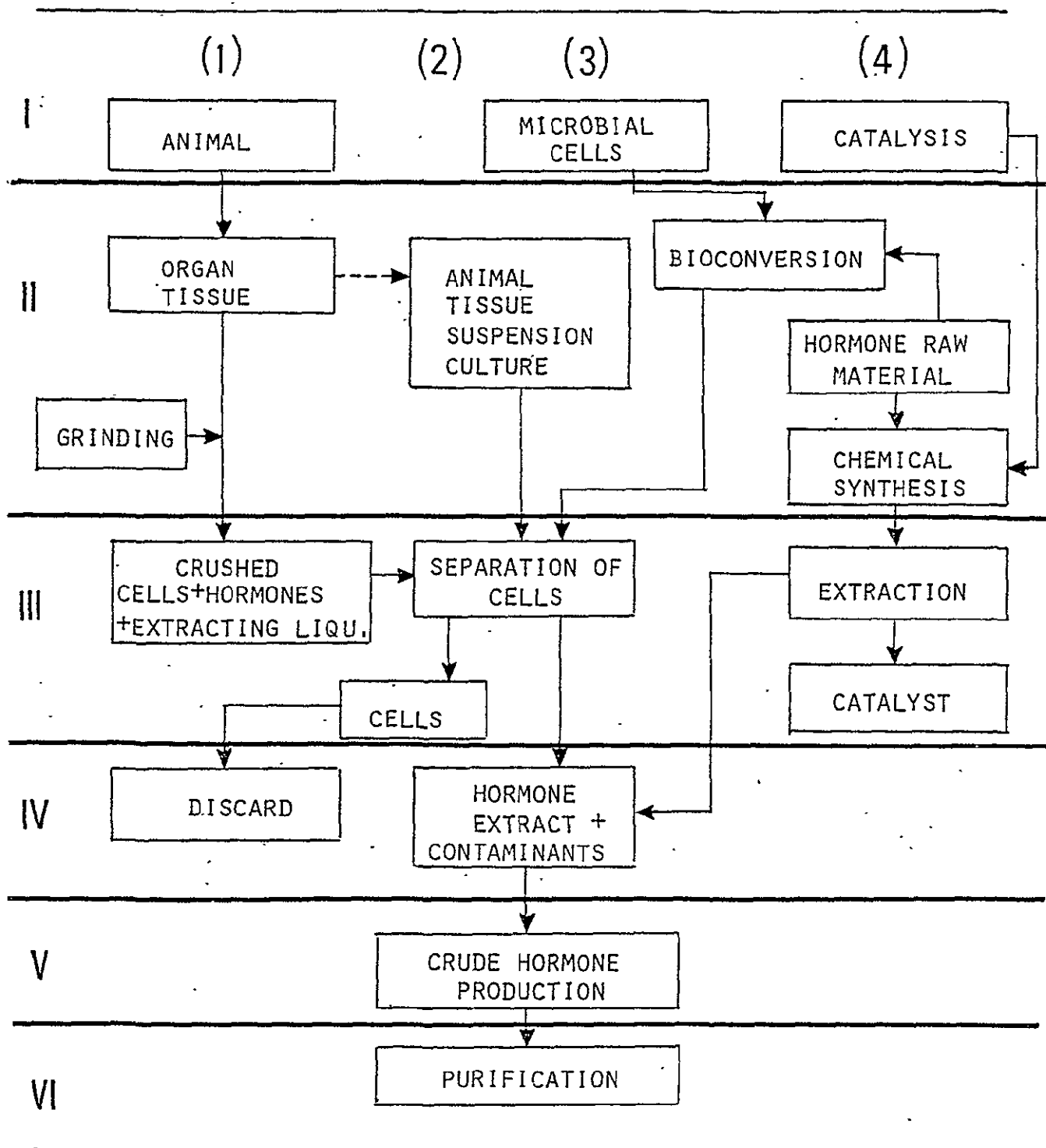

FIGURE 20

SCHEMES OF HORMONE MANUFACTURING

TABLE XII

SOURCE AND COMMERCIAL AVAILABILITY OF SOME HORMONES OF MEDICAL IMPORTANCE

HORMONE	COMMERCIAL PROD.	MW	CHEMICAL SYNTHESIS	GLAND	PLACENTA	URINE	BLOOD	IN VITRO (TISSUE)	UNITS
(1) GH	-	21,500	-	+	+	+	+	+	1 USP = 1 I.U. = 1 MG
(2) HCG	+	67,000- 68,000	-	+	-	+	-	+	1 I.U.
(3) ACTH	+	45,000	+	+	-	-	-	+	1 USP = 1 I.U. = 1.14 M
(4) T ₄	+	776.9	+	+	-	-	-	+	MG

possibility to chemically synthesize (at least T_4 and ACTH) as well as producing them by tissue cultures, T_4 , ACTH and HCG are still manufactured by extracting animal organs (glands) or from urine (GH, HCG) as well as human blood plasma (GH). . . Because of the difficulties in obtaining raw materials currently GH is not available commercially, therefore, its price could be only estimated. Tables XIII-XVI present the outlines of current recovery techniques by which the best purities of some hormones were ever achieved.

From technological point of view, these complex extraction, recovery-purification operations can be eliminated if a) the water soluble hormones are produced by tissue cultures and are secreted by the cells, b) their molecular weight makes it possible to pass ultrafiltration or dialysis membranes. These conditions make it possible to recover the hormones from tissue culture fluids (see Steps IV-V) and purify them (Step VI) directly by means of electrophoresis.

As examples show, with the exception of T_4 , hormones cited in Table XII are water soluble. Also, there is direct experimental evidence that HCG passes ultrafiltration capillary (95). In addition, being all quoted hormones peptides or proteins, they can be directly recovered and purified using EFO technique. In the case of ACTH, this technique was already utilized (c.f. Table XV).

Comparing the currently used techniques for hormone preparation with cell culture based biosynthesis, dialysis type product extraction, and EFO based recovery-purification techniques, the following advantages can be anticipated:

1. Tissues (cell suspensions) are cultured in a defined environment, therefore, the production.
-

TABLE XIII
GH EXTRACTION - PURIFICATION

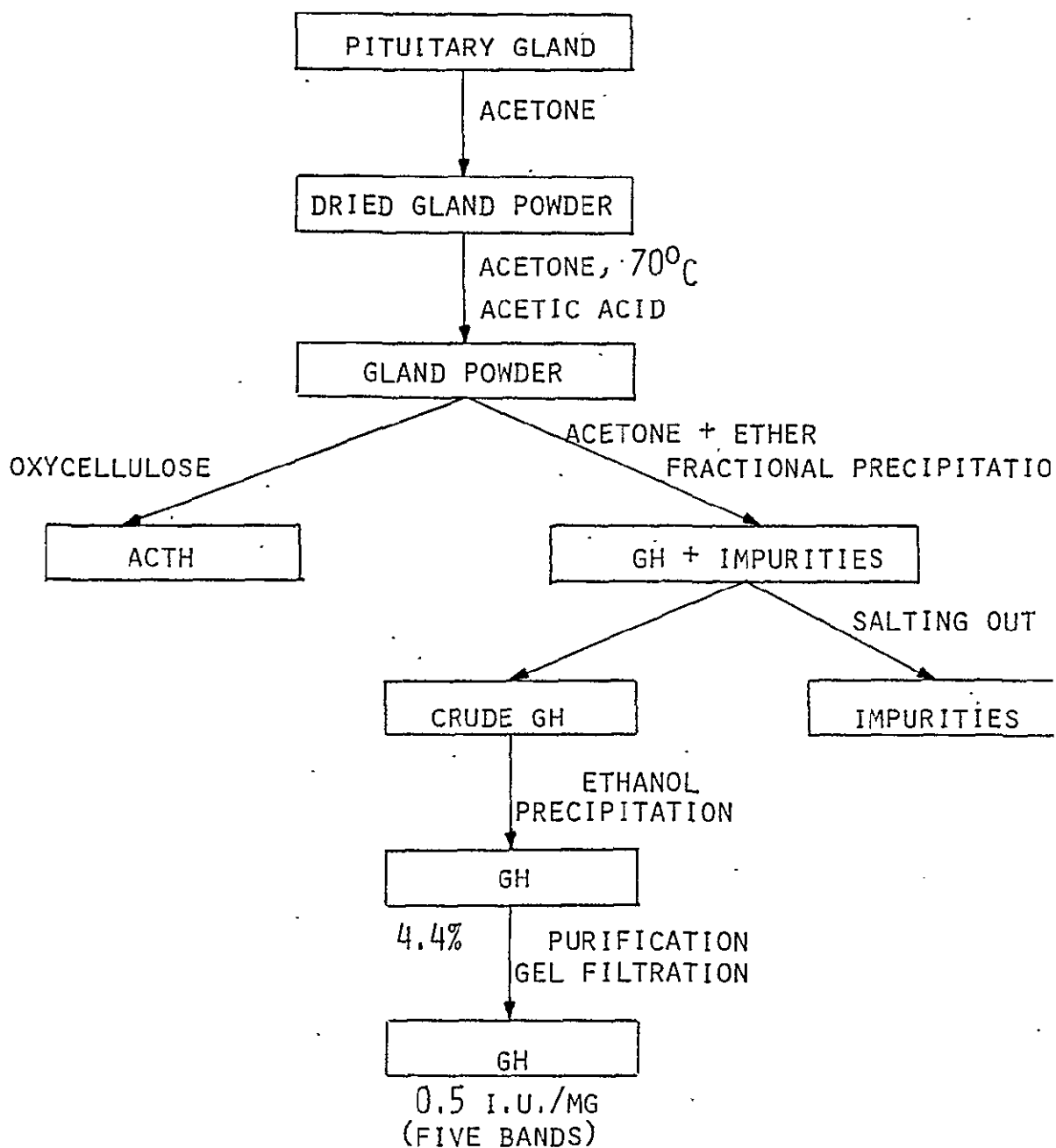

(1) RABEN, M.S., RECENT PROGR. HORMONE RES. 15, 71 (1959)

TABLE XIV
HCG EXTRACTION - PURIFICATION⁽¹⁾

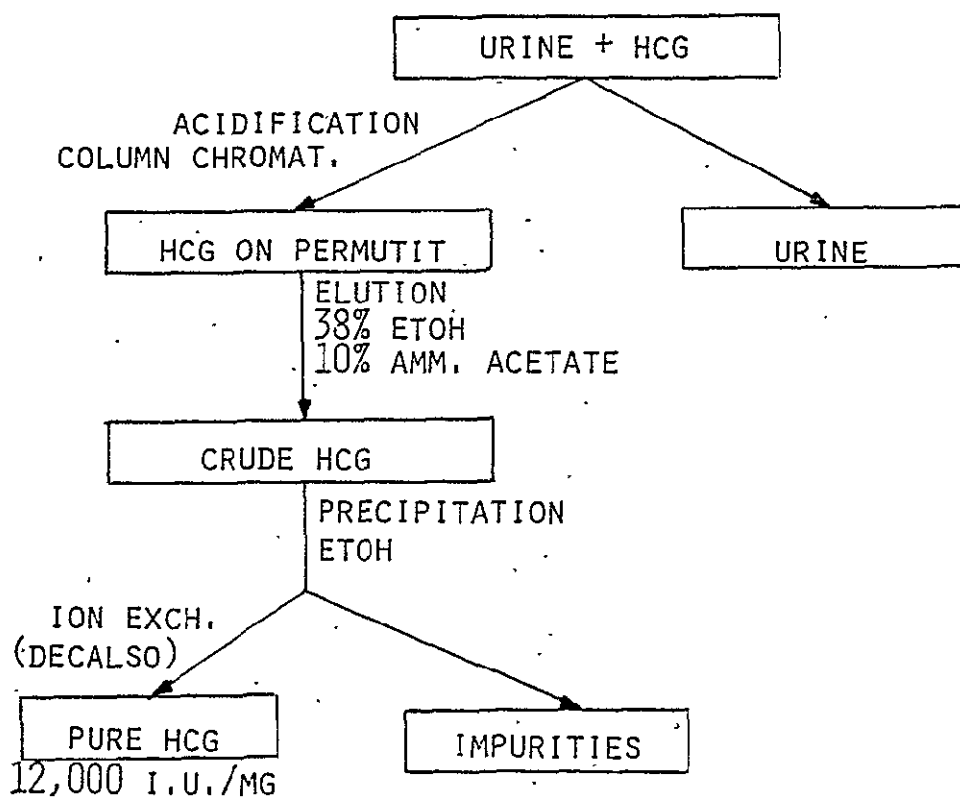

(1) MORRIS, C.J.O.R., ACTA ENDOCRINOL., COPENHAGEN, SUPPL. 90, 163 (1964)

TABLE XV
ACTH EXTRACTION - PURIFICATION

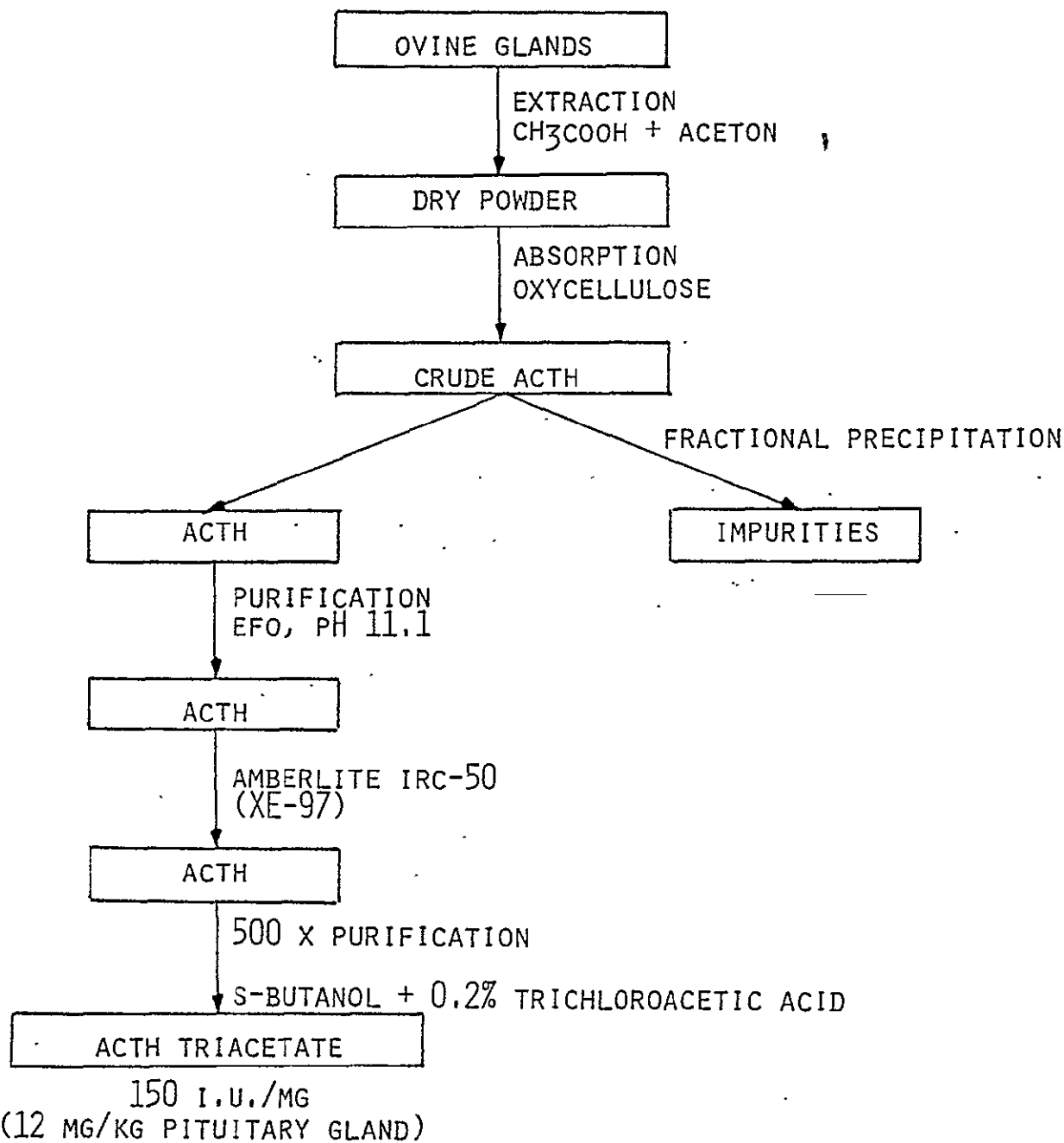

(1) LI, C.H. ET AL. NATURE (LONDON) 173, 251 (1954)

TABLE XVI.
T₄ EXTRACTION - PURIFICATION (1)

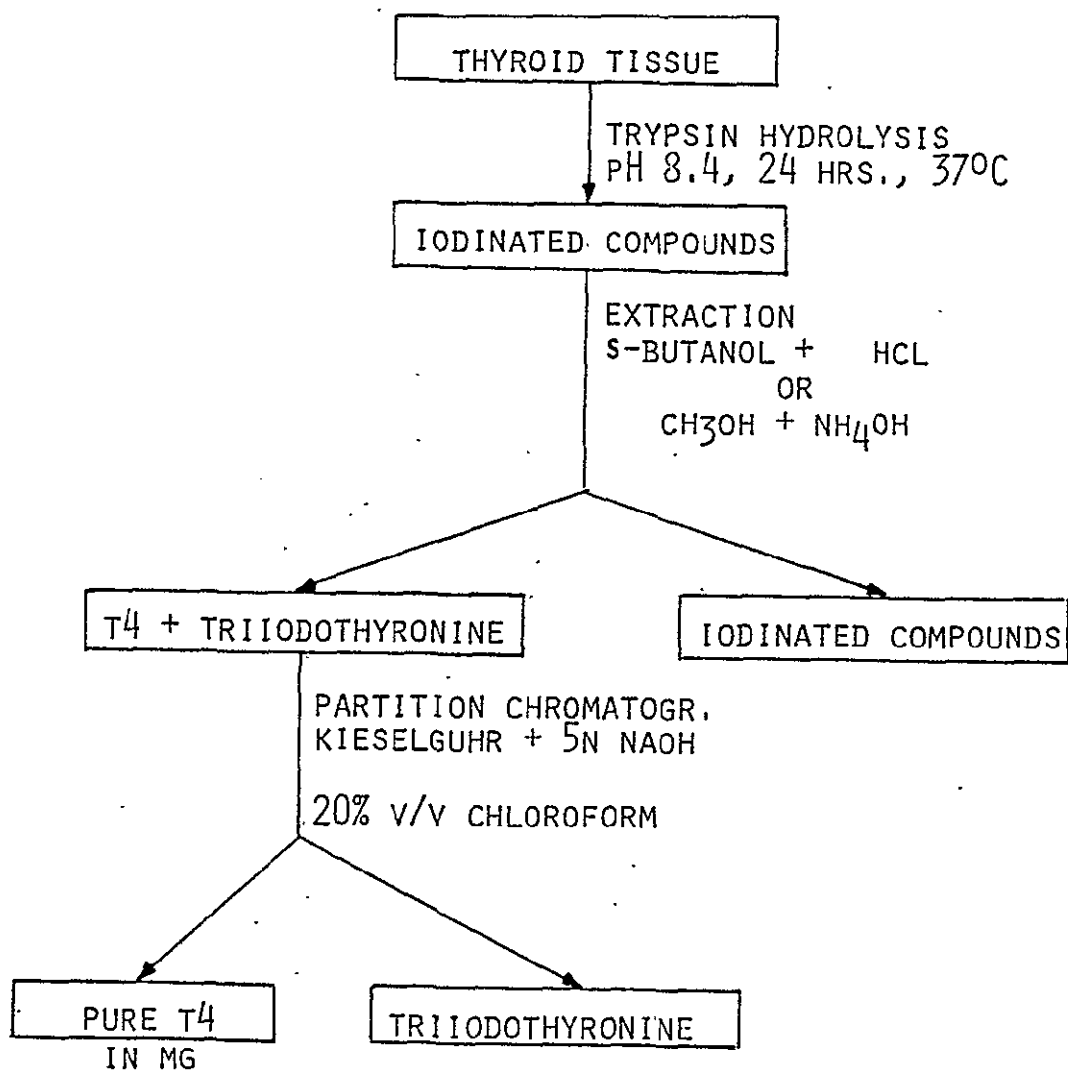

(1) TONG, W. AND CHAIKOFF, I.L., J. BIOL. CHEM. 232, 939 (1958)

rates and yield are more controllable than using organs or animal excretums as source materials.

2. Composition of tissue or cell suspension culture nutrients is generally known, therefore, the nature of contaminants from which the hormones are extracted is defined. This simplifies the recovery-purification technology.
 3. Tissue cultures were successfully utilized to produce certain hormones including GH, HCG, ACTH, T₄ and many others (see Table XI). In case of GH production, tissue culture technique seems to be economically more feasible than any other formerly used methods.
 4. Development of a tissue (cell suspension) culture based biosynthesis, dialysis based product extraction and EFO based recovery-purification technique for peptides and proteins opens up a novel way to produce compounds of pharmacological significance. As it was noted formerly (82), one of the tendencies in the psychopharmacology is to define the extrahormonal effects of certain brain peptides and hormones (e.g. ACTH). Should this research (122) prove to be successful, the novel technique developed for hormone production can be adapted to produce such substances for broader experimental and therapeutic applications.
 5. If (as expected) the microgravity environment enhances the cellular metabolic activities and (as it was demonstrated) improves the resolution of EFO based separation of charged particles, a technique primarily developed for hormone production can be utilized in the space to manufacture peptide-protein type compounds of medical, scientific importance on commercial scale.
-

6.5. HORMONES AS CANDIDATES FOR SPACE BIOPROCESSING

6.5.1. OVERVIEW OF THE POSSIBILITIES

Some aspects for selection of organic compounds for space bioprocessing were already discussed in Chapter 4.1 (p. 15). The selection criteria included:

- 1) Social need for the substance,
- 2) Efficacy (as a result of mode of action),
- 3) Cost of operation,
- 4) Cost/efficacy ratio.

As examples: a) Food (e.g. Single Cell Protein (SCP)); b) Pharmaceuticals (e.g. antibiotics, vitamins); and c) Body Metabolism Regulators (e.g. hormones) were quoted.

There is Social Need for each class of substances and it is foreseeable that this need will increase in the future (123, 124).

Efficacy of the substances in the first two classes is correlated with the absolute quantity administered into the body. This is particularly valid in the case of SCP, where the daily intake serves the purpose of maintenance of nitrogen balance of the body (125). Because of the mode of action and the social need of the substances belonging to categories a) and b), mass production was developed in the past 30 years (c.f. 123, 124 and partially Table XVII). In view of current state-of-the-art, there is a small likelihood of constructing and operating a SCP or antibiotic producing fermentation plant in Space with any chance being economically viable with existing or future terrestrial operations. The biggest technical handicap is the recycling of waste water (c.f. Table I for product concentration data) after the recovery

TABLE XVII
COMPARATIVE PRODUCTION DATA ON VARIOUS PHARMACEUTICALS

(U.S. PRODUCTION)

PART I

(124)

COMPOUNDS	QUANTITY (TONS)		VALUE (U.S. \$)		UNIT VALUE (\$ PER LB.)	
	1971	1974	1971	1974	1971	1974
<u>ANTIBIOTICS</u> (TOTAL)	8,110	9,300	136.7M	254.5M	20.5	30.8
Penicillins	3,400	3,500	27.3M	47.6M	9.98	11.5
<u>VITAMINS</u> (TOTAL)	11,800	18,500	106.6M	158.7M	5.08	5.38
Vitamin B	4,200	-	39.6M	-	5.65	-
Vitamin C	6,200	10,000	20.4M	-	1.81	-
<u>HORMONES</u> (TOTAL) *	62.0	53.0	15.1M	61.2M	98.56	514.49

* Unit value of hormones incorporates the price of all US produced hormones including steroid, peptide-protein type ones. Price of some specific peptide, protein hormones proposed for space bioprocessing is estimated in Table I (average), and in the continuation of Table XVII (specific).

TABLE XVIICOMPARATIVE PRODUCTION DATA ON VARIOUS PHARMACEUTICALS

(U.S. PRODUCTION)

(Continued)

PART II

REPRESENTATIVE PRICES OF SOME PEPTIDE-PROTEIN HORMONES

HORMONE	PURITY	UNIT PRICE* (\$)
ACTH	CHROMATOGRAPHICALLY PURE	\$11,600/g
HCG	IMPURITIES PRESENT	\$900-\$1,200/g
GH**	FROM HOG, PARTIALLY PURIFIED	\$240/g

* SIGMA Catalog and Price List (1975)

** SIGMA Catalog and Price List (1972)

of the main product. The waste water treatment in the space increases the operational cost, hence, the efficacy/cost ratio decreases.

On the other hand, hormones act as regulators of metabolic functions. Their action is amplified via intermediates (see p. 70); therefore, extremely small quantities (expressed in μg or ng amounts) are necessary to perform normal functions. Currently hormones are still manufactured (with the exception of some steroids) from animal organs or excretums (see Tables XII-XVI), the quantity produced is relatively small as well as the price is high, compared to other substances of pharmaceutical importance (Table XVII). Based on the possibility of producing some important hormones by means of in vitro culturing animal cells and simplify the recovery technique, there is a chance to manufacture some of these substances with a novel technology which, if developed, would be competitive with the "classical" processes even under terrestrial conditions.

6.5.2. SELECTION OF HORMONES FOR SPACE BIOPROCESSING

Based on the technical feasibility and the relative economic value and, in agreement with other evaluations (130), hormone production was proposed as a primary (experimental) objective for bioprocessing of substances of importance in Space (23). A further analysis seemed to be necessary, however, to define some of the hormones which may be considered as candidates for experimental trial. Criteria for the selection were set as follows:

- 1) Scientific or medical significance,
 - 2) Possibility to develop competitive technique with the currently existing production technologies, using animal tissues or cells,
-

-
- 3) A possibility that the technology developed for the space bioprocessing can be adapted to manufacture other peptide-protein type substances either on Earth or in Space.

Accordingly, we propose one or more of these hormones for consideration: 1) Human Growth Hormone (HGH), 2) Human Chorionic Gonadotropin Hormone (HCG), 3) ACTH, 4) Thyroid Hormone (T₄).

As it was shown previously, all of these fulfill requirements in criteria 2) - 3). In particular, a) there are demonstrated cases to produce the listed hormones in vitro, by means of culturing tissues or cells of various animal origin, b) if developed, the technique will offer a simpler and more controlled method to produce as well as to recover-purify the substances, c) scale-up can be assured by the proper design of the biosynthesis-recovery equipment and d) since these substances are of peptide-protein nature, the developed technique can be adapted to other materials of similar chemical composition (e.g. vaccines, other proteins (peptides) of medical significance).

In order to analyze criteria 1), it is necessary to give a brief assessment on the importance of each proposed substance in the scientific and medical fields. Generally, the following is noted:

- 1) Because of the interactive nature of hormone action, every hormone acts directly or indirectly in various ways. Therefore, GH is not only a therapeutic agent used to treat dwarfism or obesity, but acts synergistically or antagonistically in many other cases.
 - 2) Because of the low level of productivity (or even the lack of commercial production) many
-

areas for the applicability of these hormones were scarcely investigated. Therefore, development of techniques for large scale production will provide material enough to expand the scope of experiments.

- 3) ACTH, HCG and T₄ are commercially produced and their efficacy is prescribed in United States Pharmacopeia (126). Therefore, studies can be made to compare the yield, efficacy, and purity obtained using novel techniques for production.

1. GROWTH HORMONE (GH)

Figure 21 presents the amino acid sequence of the purified Human Growth Hormone (HGH) as well as its main chemical characteristics (127). There are significant differences between the MW and immunochemical behaviour of growth hormones obtained from various animals. However, bovine growth hormone (BGH) having a MW of 45,000 can be digested with trypsin resulting in a preparation which is metabolically active in humans and immunochemically reactive with anti-human growth hormone. MW of a trypsin digested, purified BGH is 22,000 indicating a subunit configuration with a unit molecular weight of 22,000.

GH obtained from rats (RHG) has MW = 46,000 which also hints of a polymer formation from 21,500 MW subunits. Rat GH₃ cells were found to be good producers of (RGH) in vitro (85). No further experimental evidence was found, however, regarding treatment of RGH with trypsin and comparison of the product's chemical and immunochemical features with those of HGH.

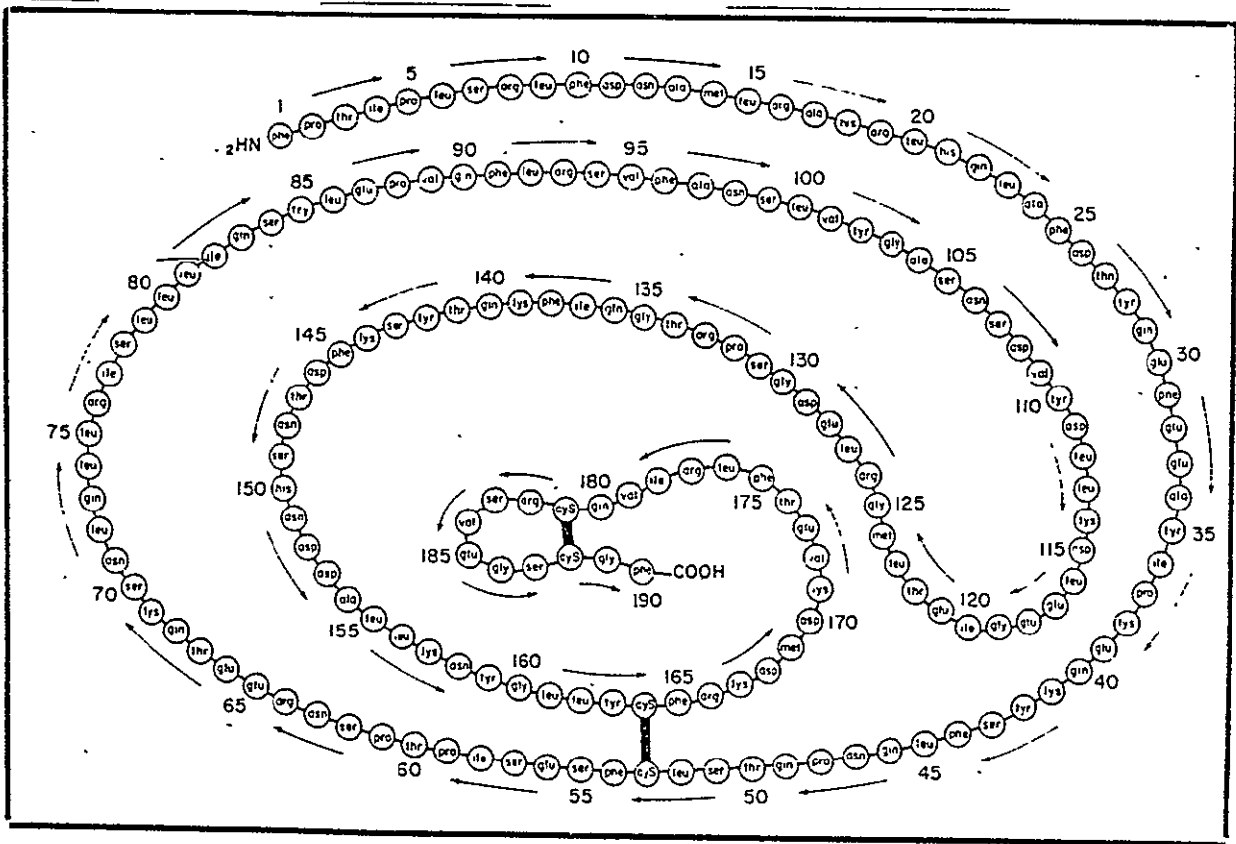

MOLECULAR WEIGHT: 21,500
 ISOELECTRIC POINT (PH): 4.9
 SEDIMENTATION COEFFICIENT ($S_{20, W}$): 2.18
 $[\alpha]_D^{25}$ (0.1 M HAC): -39°
 DIFFUSION COEFFICIENT ($D_{20} \times 10^7$): 8.88
 - S - S - BONDS: 2
 NH₂ - TERMINAL AMINO ACID: PHENYLALANINE
 COOH - TERMINAL AMINO ACID: PHENYLALANINE

FIGURE 21
 STRUCTURE AND CHEMICAL CHARACTERISTICS OF HGH

Figure 22 gives an outline of the interactive mechanism involved in control of GH secretion and its mode of action on various metabolic activities (128). In particular, the interactive effect between HGH and insulin, effect of GH on GRH secretion from hypothalamus, effect of GRH on GH activity as well as regulatory effect of GH on fatty acids are noteworthy.

The initial recognition of the pituitary's relationship to growth came from the correlation of gigantism, dwarfism, and acromegaly (due to hyperproduction of GH in adults) with pathology of that gland. Associated with growth is a markedly positive nitrogen balance; GH causes a reduction in plasma amino nitrogen, increases amino acid transport across cell membranes, and increases protein synthesis.

Growth hormone causes mobilization of non-esterified fatty acids from fat deposits while it also inhibits glucose utilization by muscle tissues and decreases the sensitivity of hypophysectomized animals to insulin. The first of these actions is the so-called ketogenic effect and the latter two are diabetogenic actions.

Current studies on GH action point to a role in the transcription or translation steps leading to protein biosynthesis. Growth hormone has also been reported to stimulate transfer RNA (tRNA) and messenger RNA (mRNA) formation (128).

In accordance with the findings with respect to the interactions of GH with other body mechanisms, its role of medical importance can be listed as follows:

Treatment in: - pituitary dwarfism,
- obesity,

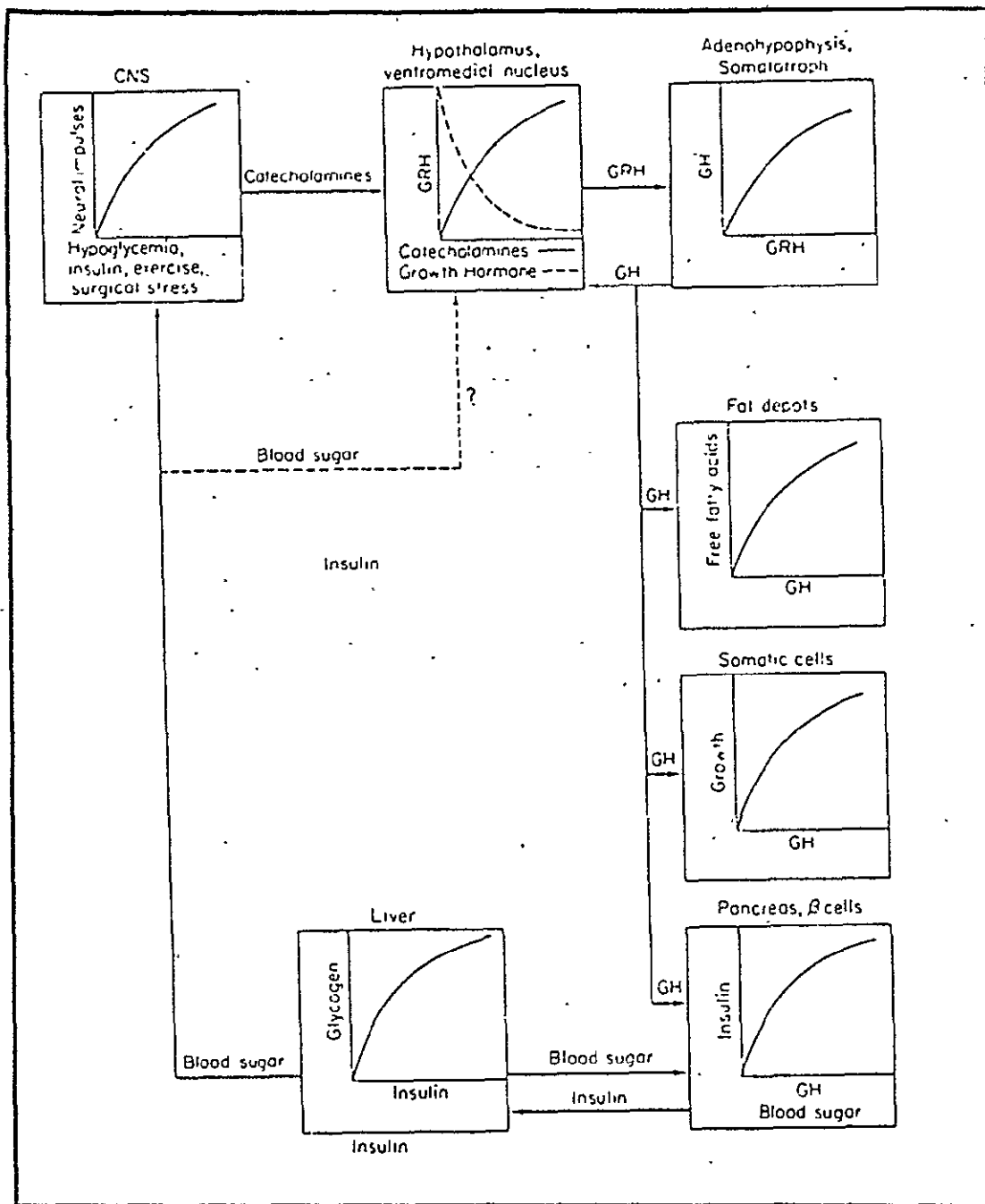

FIGURE 22
 INTERACTIONS OF HORMONAL EFFECTS RELATIVE
 TO GH

ORIGINAL PAGE IS
 OF POOR QUALITY

Potential use in:

- hyperglycemia treatment,
- T₄ related diseases (c.f. p.11)

GH's rôle in scientific research can be identified in the areas of:

- protein biosynthesis,
- ribonucleic acid biosynthesis,
- regulation of metabolic activities related to energy producing processes,
- regulation of the biosynthesis and secretion of hormones,
- interactive control of hormonal regulation of organs' metabolic function (e.g. interaction with cAMP, prostaglandins).

2. HUMAN CHORIONIC GONADOTROPIN HORMONE (HCG)

Although HCG has not been purified yet, the compound used for therapeutic purposes contains peptides and carbohydrates. An approximated MW was determined to be about 30,000 (128) with about 30% carbohydrate content (which may be contamination) composed of glucoseamine, galactoseamine, mannose, and fucose. Also, 8% sialic acid was found. The isoelectric point of HCG is 2.35.

The role of HCG is similar to that of luteinizing hormone (LH). Regulation of its secretion as well as its action is complex and is somewhat different in males and females. Figure 23 shows the interactions relative to LH secretion and its effect on various organs. Note the strong interactive function of LH with steroid hormones controlling sterility-fertility conditions in females. This generalized version of the mode

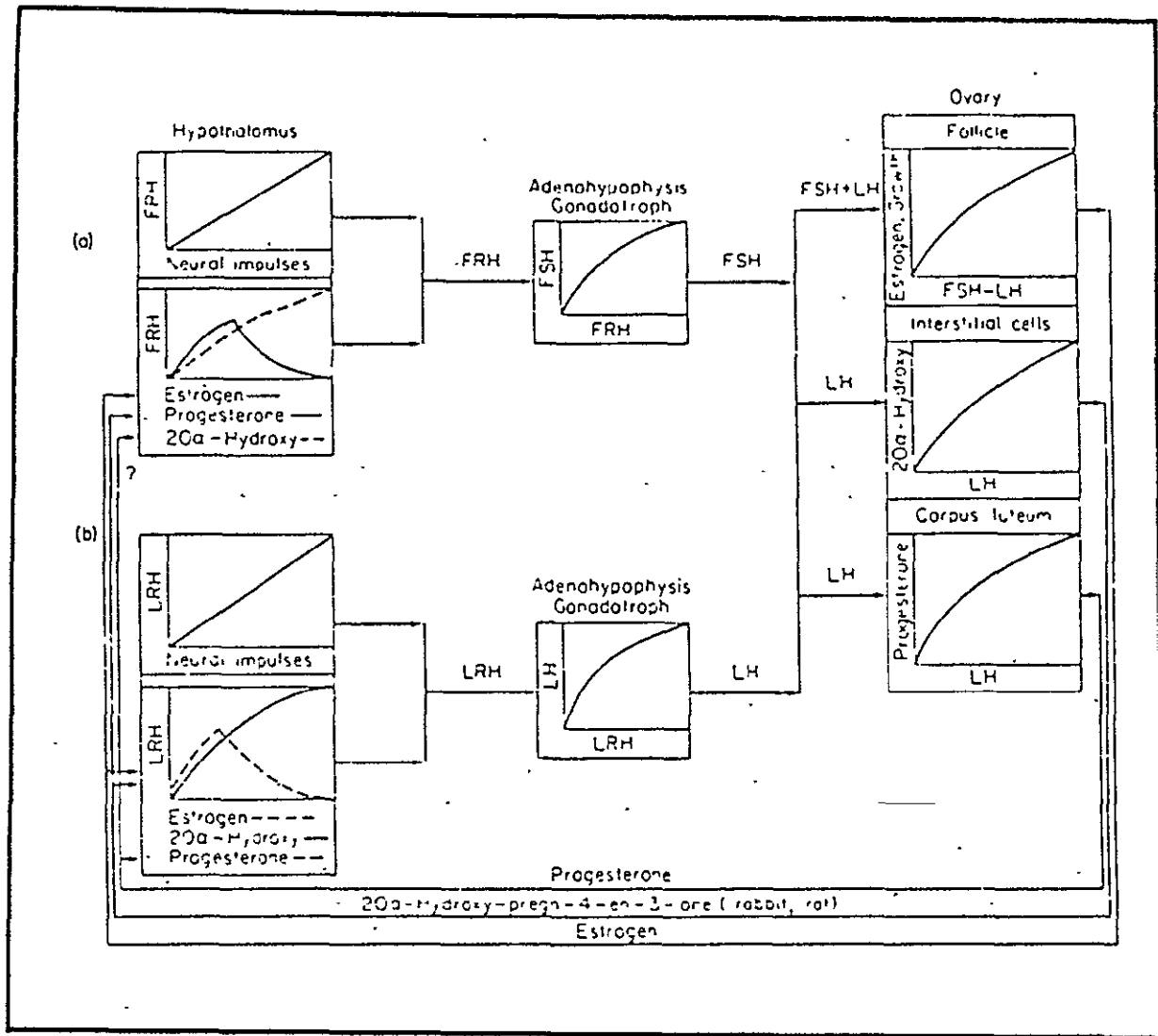

FIGURE 23
INTERACTIONS OF HORMONAL EFFECTS
RELATIVE TO HCG (LH)

ORIGINAL PAGE IS
 OF POOR QUALITY

of action (128) also points out the role of hypothalamus in the secretion and action of LH.

Currently, HCG is used in the therapy in the following areas (81, 129):

- ovarian diseases,
- hypogonadotropic eunuchoidism,
- cryptorchism,
- hypogonadism, as well as in
- obesity.

Areas of scientific research may be related to further explore the applicability of HCG in conjunction with steroid hormones related to birth control - family planning.

3. ADRENOCORTICOTROPIC HORMONE (ACTH)

This hormone is a single chain polypeptide consisting of 39 amino acid residue and having a molecular weight of about 4,500 (Figure 24). It is noted that the amino acid sequences of ACTH from four animal species (pigs, cattle, sheep, humans) had been determined. Although differences can be found (in the amino-acid sequence from 25 to 33) this does not alter the hormone's biological activity.

Figure 25 presents the regulation of secretion and interactive effects of ACTH. Again, a dual neural control of hypothalamus is observable.

Sites of action of ACTH are:

1. Effects on zona fasciculata and zona reticularis in the adrenal cortex resulting in the biosynthesis and secretion of glucocorticoid substances. This function is performed by means of reduction of ascorbic acid content, conversion of cholesterol to glucocorticoids, increasing the metabolic
-

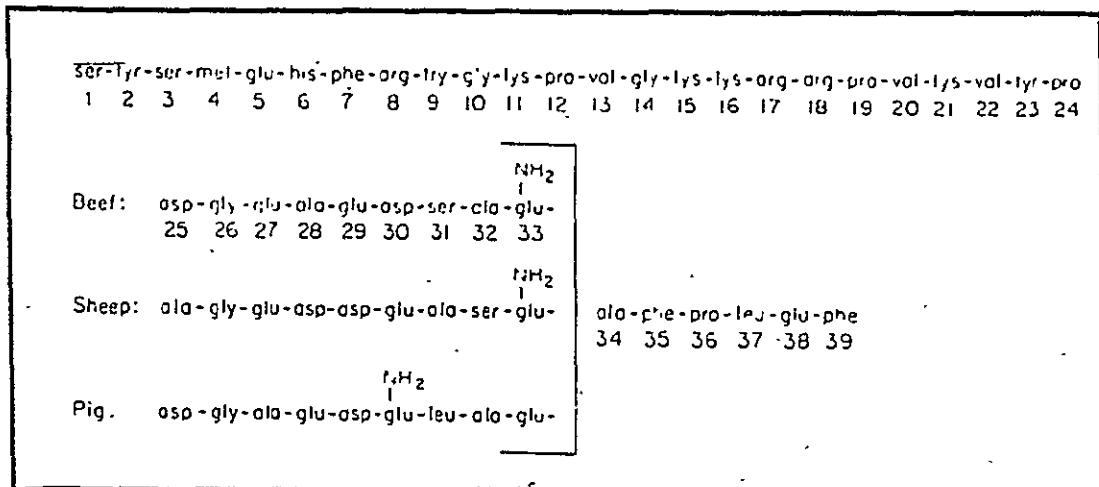

FIGURE 24.
STRUCTURE OF ACTH

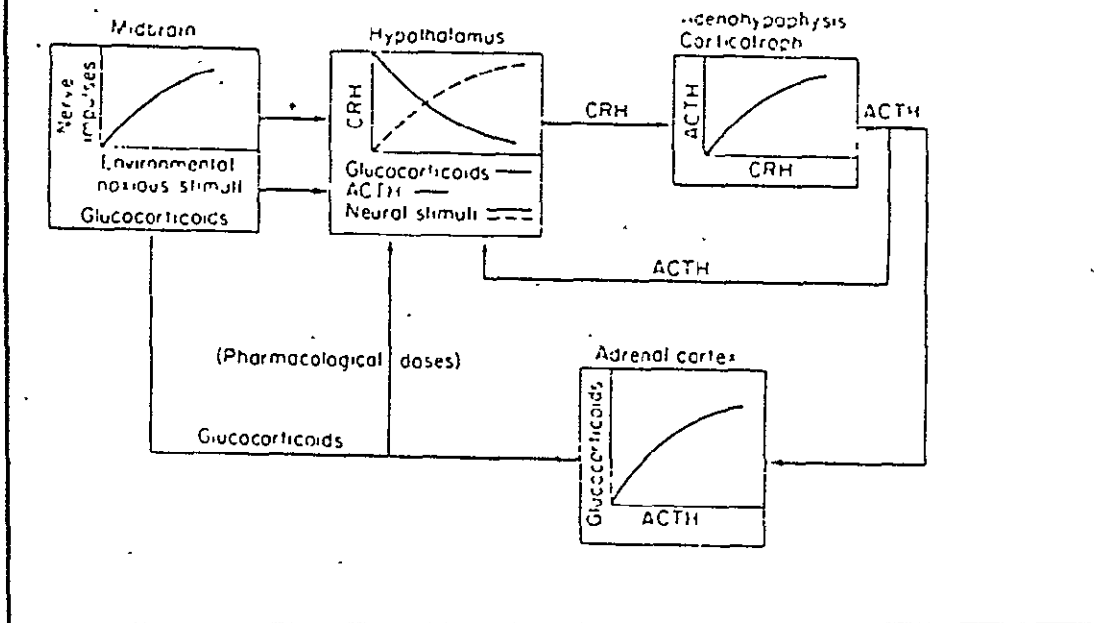

FIGURE 25.
INTERACTIONS RELATIVE TO ACTH

ORIGINAL PAGE IS
OF POOR QUALITY

rate of the tissues (enhanced O_2 and glucose uptake), increases the adenylcyclase activity resulting in cAMP biosynthesis and enhances the steroidogenesis.

2. Regulating the deposition of fats creating lipolytic action (similar to the effect of HGH, TSH and catecholamines),
3. Stimulates melanocyte formation (similar to melanocyte-hormone (MSH) effect) causing darkening of skin.

Current therapeutical application of ACTH is to:

- acromegaly,
- adrogenital syndrome,
- thyroid diseases.

Potential research areas are related to

- cAMP related control of cellular activity,
- obesity,
- experiments related to psychopharmacological substances (improving memory, reducing anxiety, etc. (82, 122)),
- interactive effects of hormones.

4. THYROID HORMONES

In particular we refer to L-thyroxine (T_4) which is one of the thyroid hormones. Its chemical structure (and its chemical synthesis) is well defined (although this compound is still manufactured from glands). Chemical composition is:

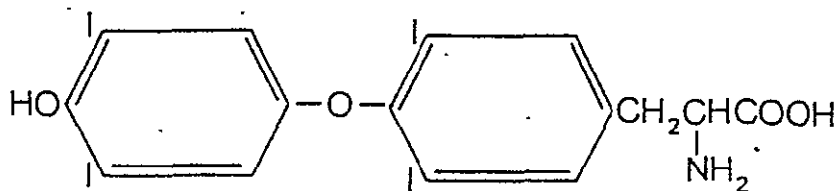

Biosynthesis of thyroxine is closely related to the iodine metabolism of the body and can be outlined in Figures 26 A and B (after the book of FRIEDEN and LIPNER (128)). Accordingly, 1) TSH exercises a regulatory role on the biosynthesis and secretion of T_4 (together with other thyroid hormone, 3,5,3-triiodothyronine (T_3)), 2) T_3 and T_4 are secreted into the plasma from which they are absorbed to influence the body metabolism.

According to FRIEDEN and LIPNER (128), the thyroid hormones regulate the metabolism of most of the adult bulk tissues - skeletal muscle, heart, liver, kidney - but do not normally affect the lungs, lymphatic system, gonads and accessory organs, nervous tissue, skin, smooth muscle, or thyroid gland. In physiological doses, the thyroid hormones have a depressant effect on the pituitary. In these affected tissues, T_3 and T_4 show no fundamental qualitative differences in their action, although T_3 acts sooner than T_4 and its effects are of shorter duration. This has been explained on the basis that T_3 is bound less firmly to serum proteins (especially the thyroxine-binding globulin) and is thus more rapidly released to tissues than is T_4 . The metabolic effects of T_4 and T_3 are therefore referred to as interchangeable. Though the thyroid hormones have a distinct chemical structure, they induce numerous effects that may ultimately be initiated by a mechanism resembling that of other hormones. In common with growth hormone, insulin, and adrenal glucocorticoids, the thyroid hormones have a general stimulatory metabolic effect on numerous tissues in the vertebrates.

There is a striking synergism between T_4 and GH. Pituitary function seems to be dependent on a

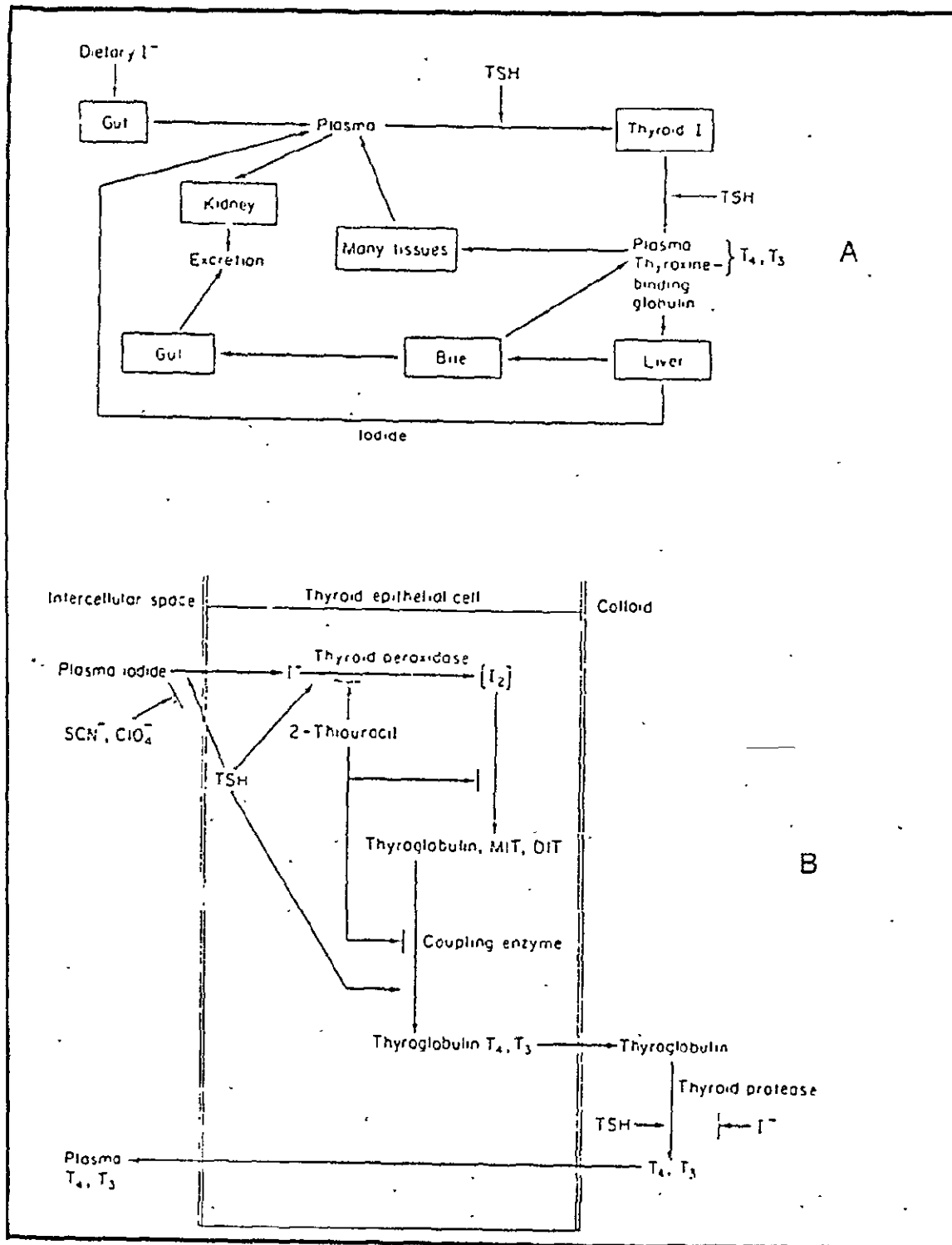

FIGURE 26
INTERACTIONS OF T_4 HORMONAL EFFECTS

ORIGINAL PAGE IS
OF POOR QUALITY

minimal secretion of thyroid hormone, an amount insufficient to produce a detectable effect on the oxygen consumption of an animal. In the absence of thyroid hormone, GH can stimulate many of the aspects of normal growth, but adequate T_4 enhances the overall rate of growth. The thyroid hormone seems to be exclusively involved in the maturation of certain tissues - particularly brain, bone, and skin.

Regarding the underlying mechanism involved, an independent stimulatory effect was found of both T_4 and GH on liver RNA polymerases. The experimental data emphasize the "permissive" effect of thyroid hormone on growth. The hormone permits normal growth and maturation; when absent, inadequate development occurs. However, it will not stimulate growth beyond the normal level, in contrast to GH. Although there is an upper limit in the growth response to thyroid hormone, excessive doses can produce an exaggerated effect on catabolic and oxidative metabolism with a large increase in oxygen consumption, a negative nitrogen balance, and a loss of weight. This is considered a thyrotoxic effect, distinct from the normal response. Thyroid hormones are contributors to the maintenance of the body temperature of homeotherms.

Calorigenesis does not account for all the effects of thyroid hormones in restoring the hypothyroid adult to the normal (euthyroid) state. A more basic mechanism appears to be involved in the T_4 stimulation of RNA polymerase activity of liver nuclei from thyroidectomized rats. The rate of cytoplasmic protein synthesis is also reported to be increased by a thyroid-hormone-induced mitochondrial factor. Greater oxygen utilization may be viewed as the result, rather than the cause, of these metabolic events.

Accordingly, thyroxine is used for therapy in the following cases (128, 129):

- acute nonsupporative thyroiditis,
- atherosclerosis,
- cretinism,
- goiter due to hypiodinism,
- Hashimoto's disease,
- myxedema,
- ovarian disease,
- spontaneous hypopituitarism,
- threatened abortion,
- thyroid carcinoma,
- thyroid disease.

Beyond this broad application, the scientific research areas can be identified as follows:

- interactive effect of T₄ with other hormones,
- calorogenic effect (reducing feeling of cold).

Examples given above are, though far from complete, clearly indicate, 1) the broad range of applicability of hormones in the medical field, 2) the potential in scientific research which has not been exploited yet, and 3) the commercial possibilities if these compounds could be produced inexpensively and in large quantities.

It is noted, that T₄ was found to be less soluble in aqueous solutions. Therefore, caution must be exercised in selection of this substance as a first candidate for Space Bioprocessing experiments. It is recommended to select this hormone as a secondary candidate if the difficulties in separation-recovery technology can be overcome by suitable experimental technique.

7. EQUIPMENT DESIGN FOR SPACE BIOPROCESSING

7.1. GENERAL OBSERVATIONS

One of the objectives of this study is the identification of an equipment which has the capability to perform bioprocessing under space conditions. In particular, the equipment will serve the purpose of carrying out bioreactions performed by intact living cells or their constituents (e.g. enzymes) resulting in compounds of interest which, then undergo recovery-purification processes. According to the objectives, the equipment in question is considered as a prototype. Its performance will enable the users to modify and scale it up to meet future technical needs.

Living cells cultured in vitro need adequate environmental conditions to express their maximum metabolic activity. This rule also applies to the biochemical or chemical reactions.

Also, during the implementation of biological or chemical reactions, it is desirable to know the status of the process. This serves the following purposes: 1) analysis of process performance and, on this basis, 2) adjustment of necessary environmental conditions.

In order to cope with these constraints, the fermentation industry gradually accumulated knowledge related to the engineering and process aspects of application of cells and enzymes in bioconversion of organic materials. In addition, techniques were developed to recover and purify the biosynthesised compounds. Experiences obtained in these areas are covered by a discipline called biochemical engineering (6). This discipline deals with the

theoretical and technical aspects of unit and systems operations related to culturing living cells or their subcellular elements under controlled environmental conditions.

According to experience accumulated in biochemical engineering, the following main rules must be observed in designing bioprocessing hardware:

1. Systems Integrity. Bioprocessing equipment as a system consists of three major elements: 1) Biosynthesis equipment, 2) Recovery equipment, and 3) Process support subsystem. From an operation point of view, all those elements are considered as one unit. This principle defines the type and number of monitoring and control elements as well as the mode of operation of the system.
2. Systems Flexibility. In fermentation practice, a properly designed bioreactor can perform more than one type of biosynthesis (e.g. a fermentor designed for penicillin-G biosynthesis can be used to produce oxytetracycline. Only the species of microorganism and the culture medium composition change). Recovery equipment and technology, however, are dependent on the chemical structure of the compound. Therefore, they vary from process to process.

In the particular case of the space bioprocessing system, the following constraints were considered:

- 1) The system serves the purpose of proving or disproving the advantages of bioprocessing in space.
 - 2) In the case of positive results, the system must be capable to perform more than one type of biosynthetic activity, the result of which
-

will be recovered by one technique: electrophoresis. At the beginning of the experiments, particularly in the test stages, at least three types of reactions can be visualized:

1) Fast, chemical and/or enzymatic conversion of compound A into B (where compound B is the subject of recovery), 2) Relatively fast microbiological process (doubling time = 20-60 minutes, product formation rate $(dP/dt) < 5G/L/HR$ and 3), Relatively slow process (doubling time = 10-20 hours, product formation rate $(dP/dt) > 5G/L/HR$).

Accordingly, the internal design and instrumentation of the biosynthesis subsystem must allow sufficient flexibility to make the implementation of enzymatic reactions, microbial fermentations, and animal cell suspension cultures possible. It is necessary to note that in all cases, the recovery subsystem (EFO) is unchanged. This makes the application of a "buffer subsystem" necessary. This system couples or uncouples the biosynthesis and recovery subsystems depending on the differences between the kinetics of biosynthesis and recovery.

3. Control of environmental conditions. Fermentation practice revealed the importance to set and maintain optimum environmental conditions which assure the maximum cellular or enzymatic functions. Factors instrumental to set the proper environmental conditions include: temperature (T), gas pressure (P), liquid pH, substrate and product concentrations. Among the substrates the carbohydrates, oxygen, nitrogen, phosphorus, certain ions (e.g. mono and divalent cations)
-

as well as bios materials (e.g. vitamins, hormones) are of importance. Among the products are the target product itself and its byproducts. Specific care must be exercised in removal of unwanted byproducts, particularly CO₂ which was shown to have influence on cellular activities (79).

The control of environmental conditions is generally performed via conventional control instrumentation composed of a sensing element, an amplifier (+ signal conditioner), comparator system, and an actuator which performs the necessary control function(s). Because of the difference in control functions, the apparatus required for control of process variables will differ significantly (Table XVIII). A brief analysis of this table reveals that considering the physico-chemical conditions existing in Space, many of the conventional manipulated variables cannot be applied in the operation of a space biosynthesis system. This is particularly valid for motor-shaft driven mixers and equipment for removal of unwanted metabolic byproducts. On the other hand, because of reportedly successful operations of pumps in zero - G, these mechanical systems can be considered for moving liquids and gases (17).

4. Automatic operation. Because of the anticipated workload aboard the Spacelab, the equipment must contain extensive electronic monitoring, process analysis and control equipment which reduces the necessity for scientists to manually operate the system. In addition, and more importantly, the prerequisite for proper evaluation of test experiments is the acquisition, analysis and logging of experimental data. This question will be discussed in detail in the subsequent sections.
-

TABLE XVIII

CONTROL SYSTEMS GENERALLY USED IN BIOCHEMICAL ENGINEERING

<u>MEASURED ESTIMATED VARIABLES</u>	<u>MANIPULATED VARIABLES</u>	<u>INTERMEDIATES</u>	<u>CONTROLLED VARIABLES</u>	<u>DISTURBANCE</u>
TEMPERATURE	COOLANT FLOW VALVE POSITION		TEMPERATURE	METABOLIC + MIXING HEAT
LIQUID FLOW RATE	PUMP MOTOR SPEED SWITCH		PUMP MOTOR SPEED	BROTH VISCOSITY
GASFLOW RATE	GASFLOW VALVE POSITION		GAS INPUT INTO THE LIQUID	VESSEL HEADPRESSURE
VESSEL PRESSURE	EXHAUST GAS VALVE POSITION		VESSEL HEAD PRESSURE	GASFLOW RATE
DISSOLVED OXYGEN LEVEL	MOTOR SPEED, GASFLOW VALVE PRESSURE REGULATOR	$K_L A$	P_{O_2}	TEMPERATURE, PRESSURE, $K_L A$
PH	REAGENT FLOW		H^+/GH^-	OVERDOSE OF REAGENT METABOLIC PRODUCTS
NUTRIENT CONCN.	PUMP SPEED	REAGENT CONCENT- RATION	S	OVERDOSE (S)
PRODUCT CONCN.	PUMP SPEED	P	PN	INCREASED RATE OF P FORMATION

7.2. OUTLINE OF EXPERIMENTS

In order to obtain statistically acceptable experimental results which demonstrate the direct or indirect effects of microgravity on (micro)-biological processes it is necessary to perform experiments simultaneously in 1-G and 0-G condition

Figure 27 presents the outline of the experiments. Four stages are considered, namely:

1. STAGE 1. Ground based experiments with the first prototype of the Basic Bioreactor System as well as other currently available equipment to develop the experimental methods and the analytical techniques to follow the course of the reactions. In this state it is essential to determine correlations between the wet chemical analytical data and the changes in signals originated from sensors which are the part of the Space Bioreactor System. This approach was successfully applied in definition of correlations between nucleic acid, protein, product biosynthesis (determined with complex wet chemical analytical techniques) and the changes in dissolved oxygen concentration, oxygen uptake, CO₂ release rates as well as in respiratory quotient (all measurable or computable by means of direct reading sensors) (21).

In case of the proposed model reaction correlations between the progress of the reaction and changes in pH, or DO are easily defined. Considering, however, the complex assay techniques relative to hormone determinations (e.g. complement fixation, radio-immunoassay, etc.) the search for correlations is an absolute necessity for future automated operations in 0-G conditions.

FIGURE 27

OUTLINE OF EXPERIMENTS IN 1-G AND 0-G CONDITIONS

	1977-1980 <u>STAGE 1</u>	1978-1980 <u>STAGE 2</u>	1979-1980 <u>STAGE 3</u>	1980- <u>STAGE 4</u>
REACTION KINETIC STUDIES	1-G -----	1-G ----- 0-G -----	1-G ----- 0-G -----	1-G ----- 0-G -----
HORMONE PRODUCTION WITH ANIMAL CELLS	1-G -----	1-G -----	1-G ----- 0-G -----	1-G ----- 0-G -----
PRODUCT SEPARATION (EFO)	1-G -----	1-G -----	1-G ----- 0-G -----	1-G ----- 0-G -----
PROTOTYPE TRIAL	1-G -----	1-G ----- 0-G -----		
TRIAL OF MODIFIED PROTOTYPES		1-G ----- 0-G -----	1-G ----- 0-G -----	1-G ----- 0-G -----

Stage 1 experiments also include individual coordinated works in product separation and purification techniques.

Minimum success criteria in this stage of the project are:

- 1) Development of the model reactions. (methodology),
 - 2) Development of the correlations between the chemical changes and the direct reading sensorial outputs; statistical analysis techniques,
 - 3) Development of (at least one) hormone production technology including the cell culture technique, the analytical methods, and correlations between wet chemical analytical data (reflecting the cell physiology-product formation) and the changes of direct reading sensorial signals as well as recovery technology. (This part of the project can be extended to Stage 2).
 - 4) Development of one working prototype of the Basic Bioreactor System in which a) Model reactions can be implemented under 1-G condition; b) Hormone production studies can be started.
2. STAGE 2. Sounding Rocket Experiments with model reaction performed in the Space Bioreactor. Parallel experiments are run in 1-G condition and the previously determined signals reflecting the process status are introduced into a ground based computer which performs the statistical analysis of data obtained from the concurrent 1-G and 0-G experiments.
-

Minimum success criteria are:

- 1) Definition of the operating characteristics and final design of a Space Bioreactor prototype. (Making the necessary modifications and experimental retesting of designs completed).

In this stage of the project ground based hormone production and product recovery-purification techniques are continued.

3. STAGE 3. Space Shuttle Based Experiments.

In this stage, model reaction kinetic studies will be run incorporating chemical reactions (if necessary), enzymatic reactions, however, the first 1-3 days microbiological model reaction kinetics will be the main area of interest. Also, the first product recovery-purification technology trial will be implemented jointly or separately from the Space Bioreactor operation. An experimental trial for tissue cultures in O-G may be possible depending on the development of this technology in the first two stages of the project.

In all cases simultaneous experimental runs will be implemented comparing the 1-G and O-G data by means of on-line, real time (ground based) computer operation

Minimum success criteria are:

- 1) Definition of differences between model cell growth and product formation kinetics which ultimately defines the effects of O-G on cellular metabolic activities.
 - 2) Definition of the efficacy of the peptide-protein recovery, purification technique in O-G.
-

-
- 3) Definition of the necessity of further prototype modification, scale-up criteria.
 - 4) Development of the control strategies necessary to implement fully automated, coordinated operation of the Space Bio-processing Equipment (Space Bioreactor + Recovery-Purification System + Auxiliary Equipment).
 4. STAGE 4. Spacelab Based Experiments.
Simultaneous operation of the Space Bio-processing Equipment in 1-G and 0-G conditions. Anticipated duration is up to one month per run (for hormone (peptide-protein production)), 1-6 days (for biochemical, microbiological experiments), 1-24 hours (for chemical synthesis experiments).

It is emphasized that implementation of this stage of the project depends on the advantages revealed in Stage 3. Also, in Stage 4 wet-chemical analytical experiments can be performed as well as on-board computer based process analysis and process control can be implemented. The information obtained by this means provides the engineering data for construction of the first, fully automated pilot-plant for space bioprocessing purposes.

7.3. BASIC BIOREACTOR DESIGN

7.3.1. GENERAL

In view of the previous constraints, a Basic Space Bioreactor System (SB1) is identified as a prototype equipment with the capability of:

1. Performing organic chemical, biochemical reactions as well as serving as culture vessel for culturing
-

-
- a) microbial cells, b) animal tissues and c) animal cells in suspension. This system will be used for l-G and O-G experiments with the premise that it goes through modifications subject to experiences with the equipment, performance as well as developments and findings of new model reactions and cell culture techniques.
2. Monitoring essential process variables such as T, P, pH, dissolved oxygen concentration (DO), oxidation-reduction potential (ORP). Also, liquid flow rate, flow rate of reagents and gases are known as predetermined values. In addition, provision for sampling wet-chemical analysis is included. Provision is made to perform gas analysis using a gaschromatograph or (in later stages of operation) mass-spectrometer.
 3. Controlling essential environmental factors including, at least, T, P, substrate(s) input and product-byproduct removal.
 4. Acquiring and transmitting signals related to the process status either to a multi-channel recorder or (by telemetry) to a computer for data analysis.
 5. Discharging culture medium to product recovery.

The conceptual design of this multipurpose (convertible) Basic Bioreactor System (SB1) is shown in Figure 28.

7.3.2. RATIONALE OF THE BIOREACTOR DESIGN

Under terrestrial conditions, bioreactors are generally sterilized with steam (6). Moreover, in order

CONCEPTUAL DESIGN OF SPACE BIOREACTOR

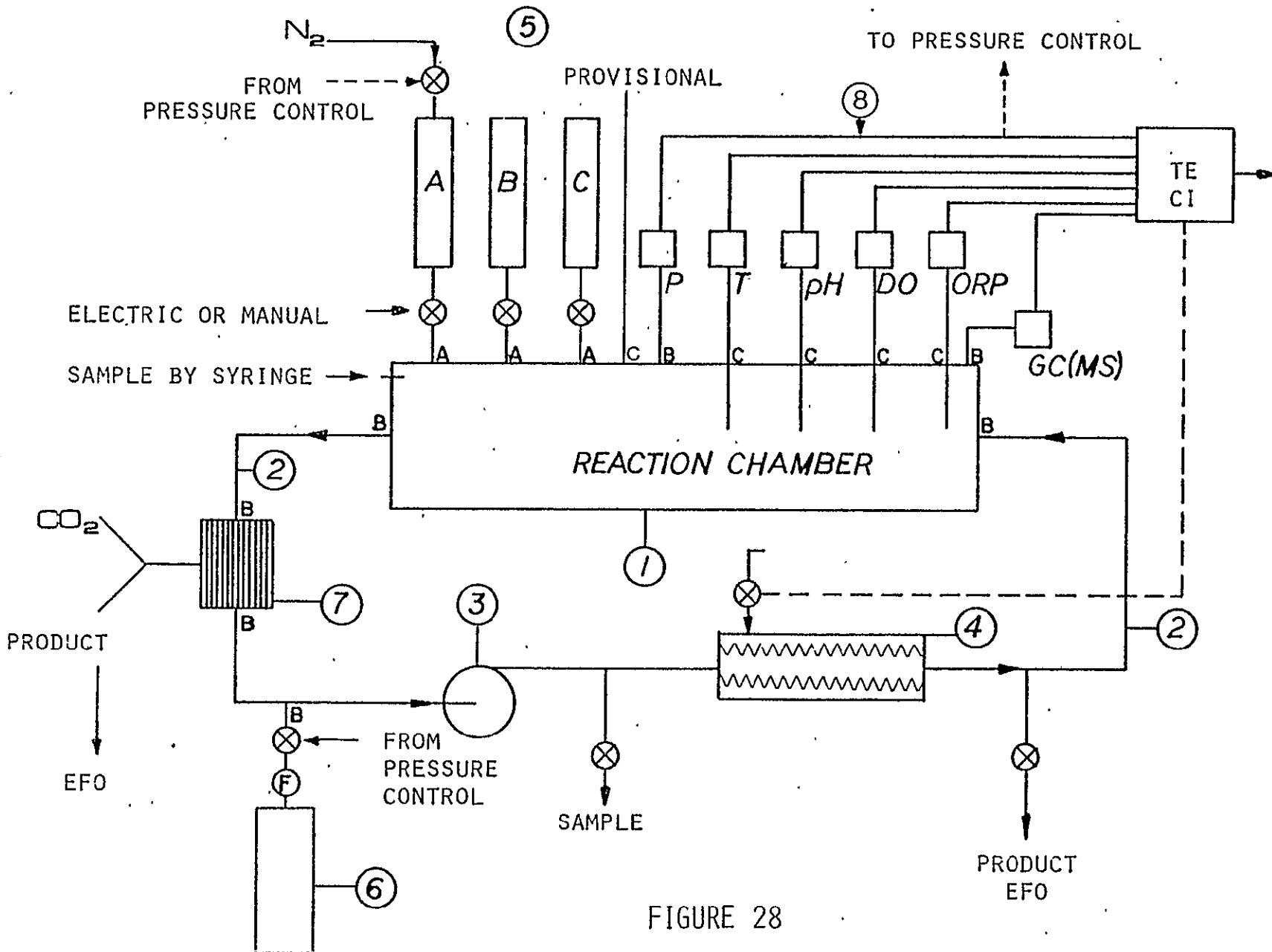

FIGURE 28

to assure sterility during the process, steam is constantly supplied to the bearing house through which an agitator shaft is introduced into the culture vessel. Production of steam in a Spacelab would require unnecessary payload. Therefore, the conventional "fermentor" arrangement, (having shaft driven mixers), was rejected and a tubular loop bioreactor design was selected, instead (131). Operational characteristics of this model were investigated recently (132). According to experimental data (132), the system behaved similarly to a conventional stirred tank reactor and was scaleable from a bench model to pilot-plant scale. In particular, the fluid circulation was found simpler, the oxygen transfer was sufficient to support vigorously growing S. cerevisiae and C. tropicalis (on n-hexadecane) cultures, and practically all the above mentioned, process and control variables were measurable and controllable.

An additional feature of this design is the possibility to apply dialysis systems (22) considered essential for removal of unwanted byproducts (e.g. CO₂). Moreover, such system can be sterilized using ethyleneoxide -CO₂ mixtures instead of steam. However, direct steam sterilization (for terrestrial experiments) is also possible.

The equipment can also be used as a chemical or biochemical reactor as well as a culture vessel assuring growth both for animal tissues or cells in suspension.

The only moving part of such a system is a set of pumps which significantly reduces the risk of mechanical failure during operation and creates less shear than a conventional mixing apparatus equipped with agitation blades.

7.3.3. ELEMENTS OF BASIC BIOREACTOR SYSTEM

According to Figure 28, the Basic Bioreactor System has the following major elements:

- 1 REACTION CHAMBER (RC) with inlet and outlet parts (estimated total volume: up to 500 cm³, estimated working volume up to 375 cm³). In case of Sounding Rocket experiments, RC total volume does not exceed 100 cm³.
 - 2 PIPE (PE) with diameter to allow liquid circulation with a velocity up to 2-3 m/sec. Various quick-fit disconnect port locations are welded into the pipe. Material: 316 SS.
 - 3 PUMP (PU) connected to Pipe 2 assuring the culture liquid circulation with a speed up to 500 cm³/min. Pump is steam and/or ethyleneoxide sterilizable.
 - 4 HEAT EXCHANGER (HE) with the capacity to remove about 1,000 kcal/hour heat (regulated by T controller),
 - 5 REAGENT VESSELS (RV) directly connected with Reaction Chamber 1. Type and size of vessel will vary depending on the task they are involved in. Generally, RV has the following design characteristics:
 1. Inlet/outlet ports regulated by electronic or manually operated valves,
 2. Quickfit connection with RC,
 3. Liquid transfer is performed by gas (N₂) pressure
 4. Sterilization either by ethyleneoxide - CO₂ gas mixture or by steam.
 5. Working capacity varies from 10 cm³ to 100 cm³.
-

-
- 6 AIR/GAS INTRODUCTION SYSTEM (AG) consisting of:
- 1) connections to the liquid circulating pipe,
 - 2) pressure controller with P signal, activated or manually operated valves;
 - 3) gas filter (F) of 0.22 μ particle retention, and
 - 4) gas cylinders connected to the filter.
- 7 DIALYSIS UNIT (DU) connected to Pipe which enables removal of products.
- 8 INSTRUMENTATION SYSTEM (IS) consists of a number of subsystems. These are listed in Table XIX along with their specifications for the sensors, measuring and controlling accuracy as well as the data logging capabilities.

Function of the Instrumentation System is:

- 1) Maintenance of the necessary environmental conditions with specific respect to temperature and pressure control,
- 2) Follow the physico-chemical and chemical changes reflecting the reactions performed in RC. This applies to changes in pH, DO, ORP, GC/MS and wet-chemical analysis (WCA).

Vendors for each individual subsystem will be specified during the design of prototype for manufacturing.

Process Variable Control. In the first prototype three controls, namely temperature of the culture liquid, the pressure, and liquid circulation rate are essential.

Temperature control is performed by a thermometer regulated heat-exchanger (HE) with a required accuracy of $\pm 0.25^{\circ}$ C during the reactions.

Pressure is controlled by means of a pressure controller using the pressure transducer's signal.

TABLE XIX

SPECIFICATIONS OF THE INSTRUMENTATION SYSTEM ELEMENTS

PROCESS VARIABLE	SENSOR	RANGE	ACCURACY	SIGNAL OUTPUT	SIGNAL INTRODUCED	NOTES
(1) TEMPERATURE	THERMISTOR	+5-+130°C	0.25°C	4-20mA 0-100mV	TE, CI, CO, R	HE CONTROL
(2) PRESSURE	P TRANSDUCER	1-2 ATM	±0.1 ATM	4-20mA 0-100mV	TE, CI, (CO), R	CO (OPTIONAL)
(3) DO	GALVANIC DO PROBE	1-100% OF DO	±1%	4-20mA 0-100mV	TE, CI, R	CO (OPTIONAL) VALVE ACTUATION
(4) PH	GLASS, COMBINED	2-10PH	±0.1 PH	4-20mA 0-100mV	TE, CI, R	VALVE ACTUATION
(5) ORP	GLASS, COMBINED	±500mV	±5mV	4-20mA ±0-100mV	TE, CI, R	--
(6) VOLATILE COMPOUNDS	GC/MS	--	--	4-20mA	(TE, CI), R	FUTURE APPLICA- TION
(7) SUBSTRATES PRODUCTS	SPECTROPHOTO- METER	--	--	4-20mA	(TE, CI), R	GROUND APPLICA- TION

LEGEND: TE = TELEMETRY; CI = COMPUTER INTERFACE; CO = CONTROLLER; R = CHART RECORDER

The controller regulates the air/gas introduction valves. The principle of operation is shown in Figure 29. Mixtures of N₂/O₂/CO₂ gases are introduced at a specified rate from gas cylinders (6A, 6B) through a filter. For reagent addition by pressurization with N₂, the rate of N₂ gas introduction from cylinder 6B proportionally decreases to compensate for pressure changes in the system. The flow valve, which regulates the specific flow rates of gases, can be regulated manually or by a control signal originated from a dissolved oxygen controller.

Liquid circulation rate is adjusted manually using a switch on the circulating pump. Start of the pump is actuated by ground based signal (Stage 2).

pH is controlled by addition of fresh nutrients or using buffer systems in the early stages of the project. Optimum temperature, gas flow rate, and liquid circulation rates for Stage 2 experiments will be defined by ground based experiments (in Stage 1).

Physical connections between the system elements.

Connections between RVs, PE sensors as well as AG gas cylinders will be made by means of quickfit disconnects. This type of connection provides airtight (aseptic) operational characteristics for a complex animal cell suspension culture systems (98) and give flexibility to the system usage.

Type "A" connections are Swagelok QM series quick connects (Figure 30A). Part XI is welded onto the RC's wall, part X2 is connected to the pipe attached to the Reagent Vessel. This mechanism makes it possible to attach any type of RV to the Reaction Chamber as well as change RV upon demand.

Type "B" connections (Figure 30B) work on the basis of similar principle as Type "A" connections.

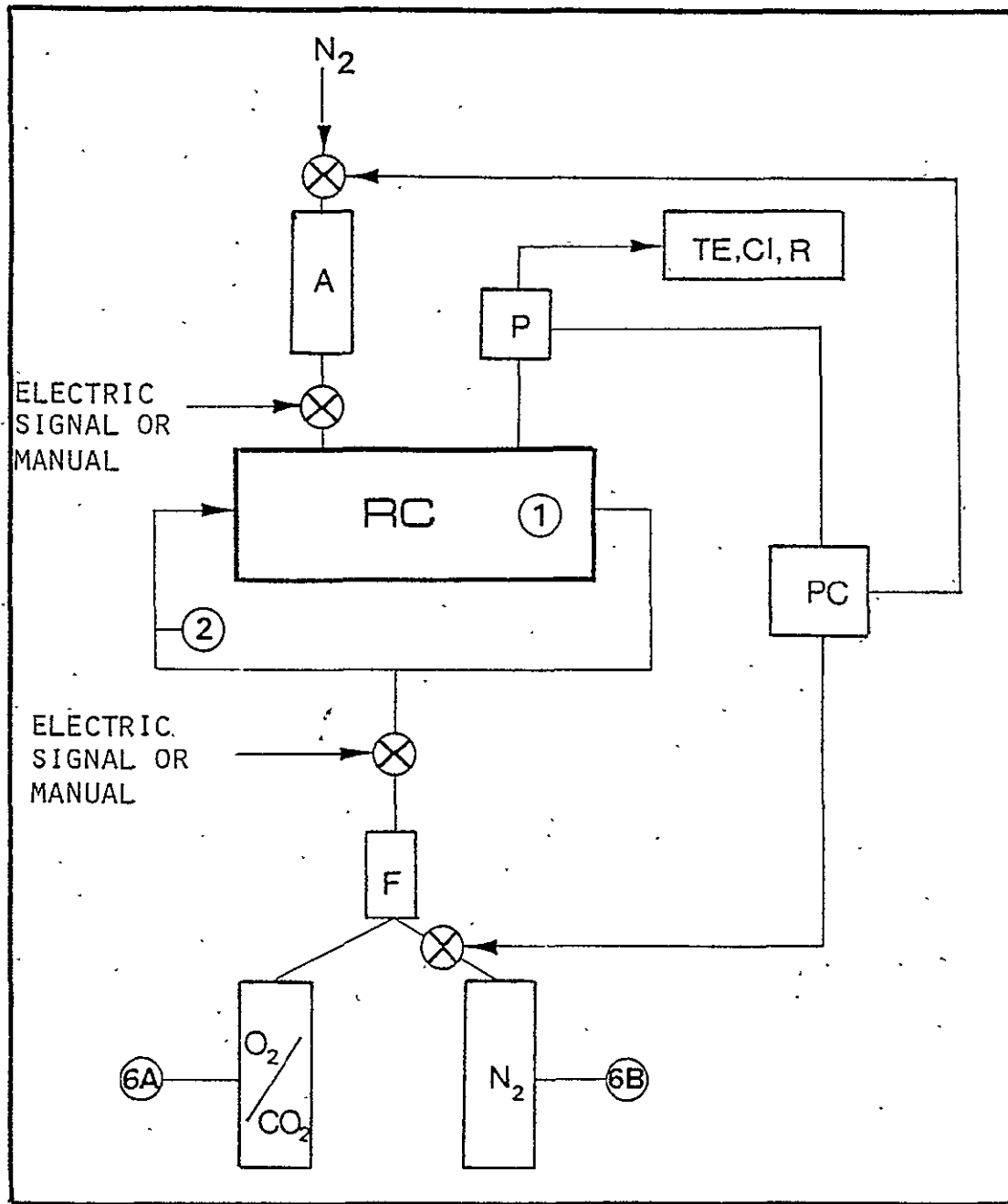
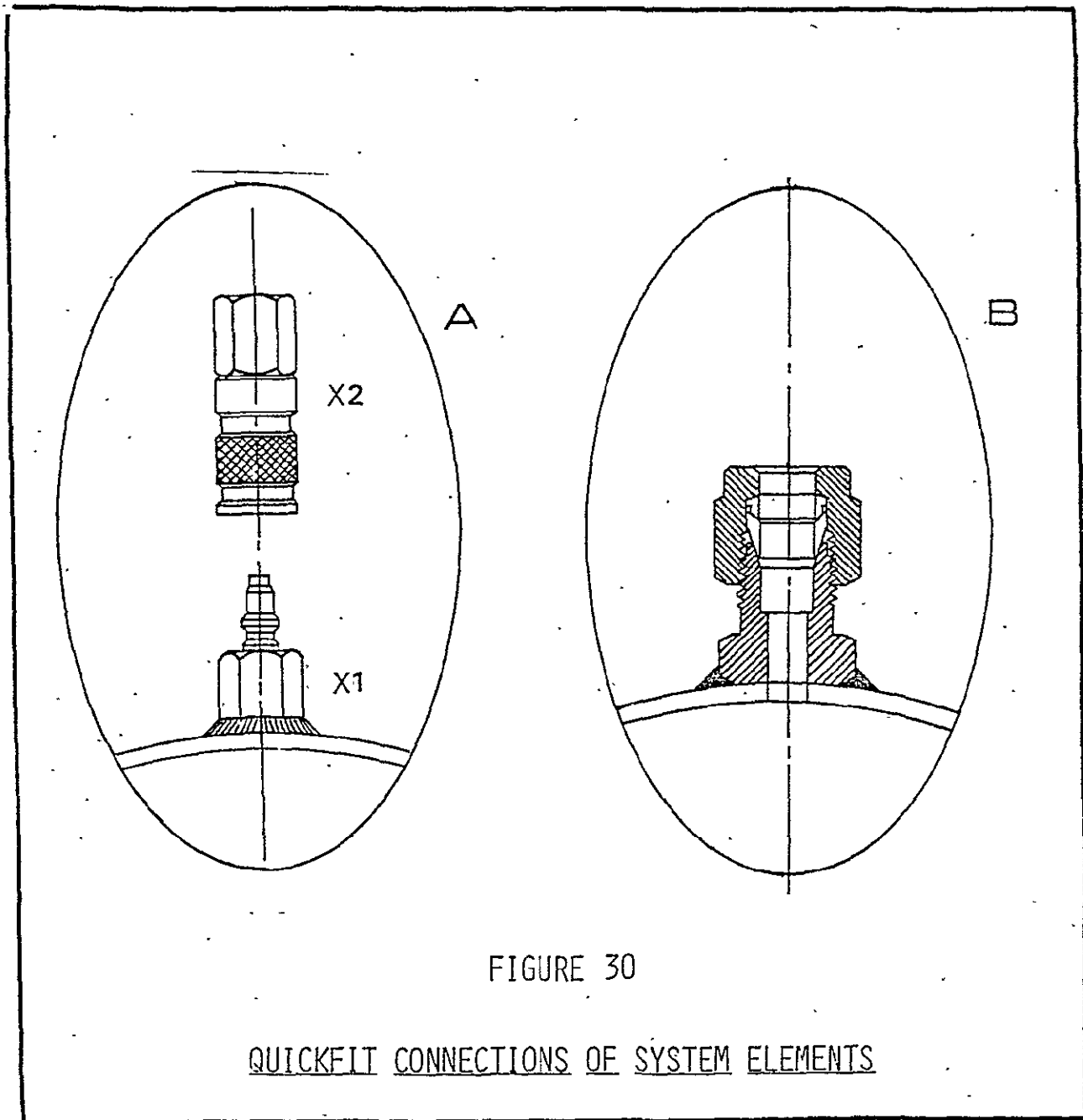

FIGURE 29

PRINCIPLE OF PRESSURE CONTROL

LEGEND: PC = PRESSURE CONTROLLER



They make it possible to interchange different type Reagent Vessels and dialysis units with the liquid circulation pipe. They also serve the purpose of attaching gas cylinders to the liquid circulating pipe. In this case, however, the connection is manually secured.

Type "C" connection (Figure 31) serves the purpose to hold sensors inserted into the Reaction Chamber. Anticipated bore size is 31 mm which, in principle, defines the outer diameter of the sensor. This technical approach makes it possible to interchange sensors (e.g. interchange ORP probe with pCO₂ sensor). Note, a provisional, Type "C" connection in order to assure insertion of new sensor elements to the Reaction Chamber.

Interchangeability of Reactor Chambers. The quick-fit type connections offer an unique opportunity to interchange system elements. In particular, replacing Reaction Chambers is of importance. Currently, three major types of RC are envisioned, namely:

- 1) 316 SS RC (RC1) which serves the purpose of conducting organic chemical, enzymatically catalysed reaction as well as culturing of freely suspended cells (e.g. bacteria or animal cells which grow in suspension).
 - 2) Titanium RC (RC2) which offers an opportunity to grow animal cells in mono-or multilayer (perfusion culture). In this case, one or more Reagent Vessel carries the necessary culture medium prepared and sterilized under terrestrial condition and introduced into the Reaction Chamber by pressure.
 - 3) Capillary Chamber (RC3) made of 316 SS or suitable plastic material. This serves the purpose of
-

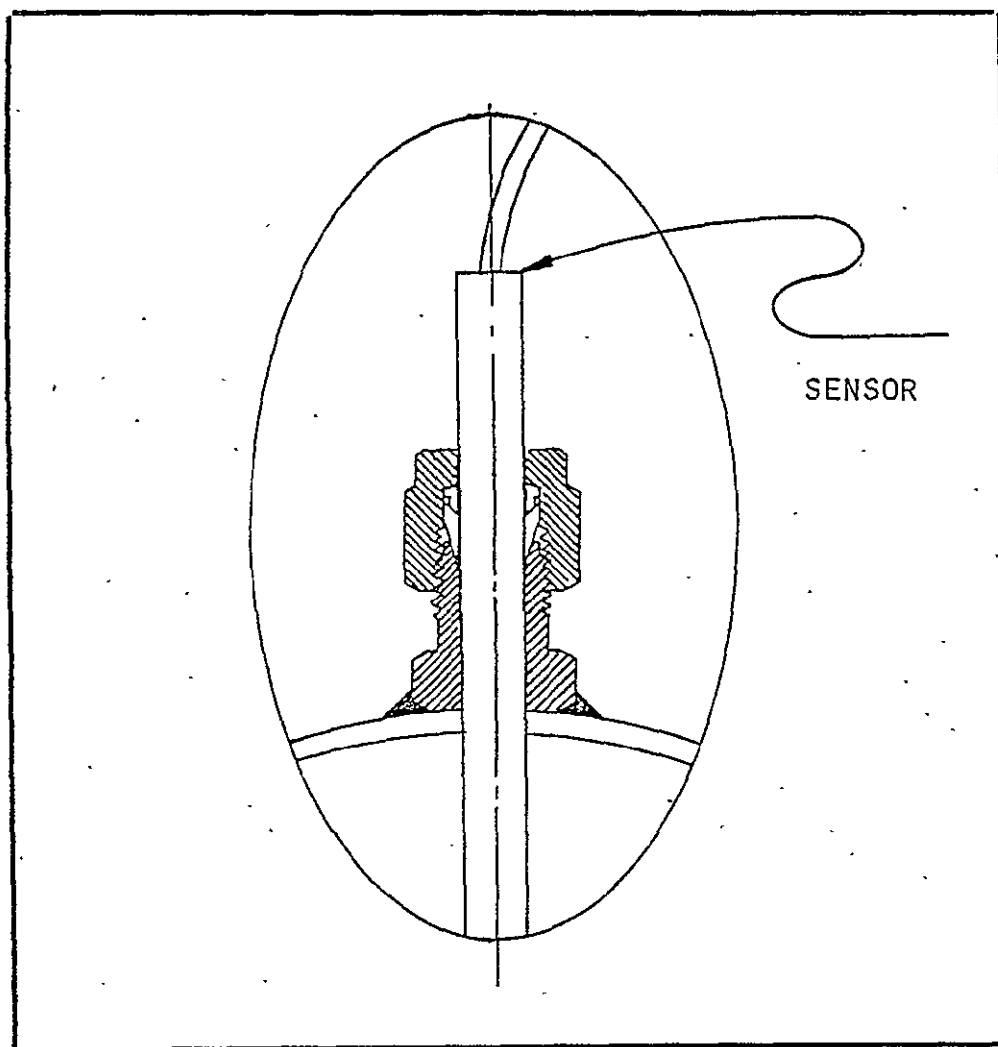

FIGURE 31

ATTACHMENT OF SENSORS TO THE REACTION CHAMBER

supporting growth of animal cells on micro-capillaries. Nutrients are introduced in a manner similar to that described in point 2) above.

With this configuration, essentially all possibilities for reactions and bioprocesses referred for the studies mentioned in Chapters 5 and 6 can be implemented both under terrestrial and microgravity conditions.

7.3.4. PROCESS STATUS ANALYSIS AND LOGGING SUBSYSTEMS

Based on the experimental design for the project, the following hardware is necessary to monitor the process status, acquire and transmit signals, and for processing and logging of data:

1. Sensors inserted into the Reaction Chambers,
2. Wet-Chemical Analytical Equipment (spectrophotometer, gaschromatograph, mass-spectrometer),
3. Amplifiers and Signal Conditioners,
4. Telemetry signal transmission system,
5. Computer Interface,
6. Computer and peripherals,
7. Multichannel Recorders (analog or digital).

Figure 32 presents a schematics of the hardware configuration required for the Sounding Rocket, Space Shuttle and Spacelab as well as the ground based experiments. It is noted that the process analysis and data logging hardware remains the same for the 1-G experiments, whereas the requirement for hardware increases with the progress of O-G based experiments. Pilot-plant version of the Space Bioprocessing System will require a different interface and process controller design.

Sensors-Amplifiers. According to the Instrumentation System specifications (p. 132 and Table XIX) all of

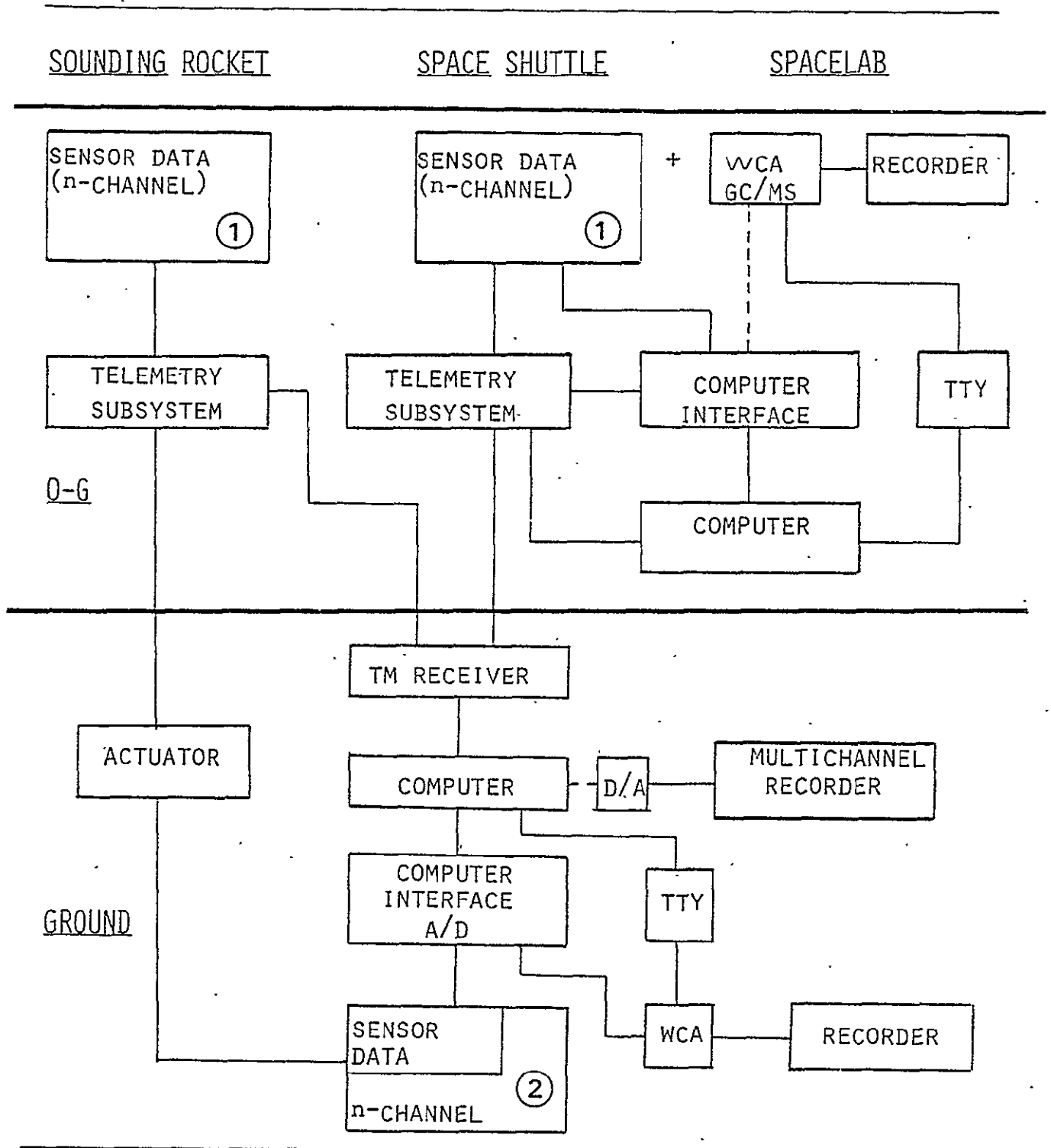

FIGURE 32

SCHMATIC OF HARDWARE CONFIGURATION FOR
SIMULTANEOUS O-G AND GROUND BASED EXPERIMENTS

the direct reading sensors are inserted into the Reaction Chamber(s) and the signal is amplified as well as conditioned to result in a 4-20 mA analog signal, proportional to the measurement range of the particular variable. These signals are introduced either to a Telemetry Subsystem and/or to a Computer Interface-Computer System for further data processing and logging.

Wet-Chemical Analysis System. A provision is assured to connect a GC/MS to the Reaction Chamber either for on-line, real time measurement of compounds of low molecular weight (such as N₂, O₂, H₂O (vapour), or compounds of MW 100). The provision houses a septum for a syringe or an automatic sampler for collection of sample from the reactor "headspace". Data are sent either to a Telemetry System (Stages 3 and 4) or directly into a computer interface and/or are recorded. An additional sampling port is provided to take samples for spectrophotometer based wet-chemical analysis. Similar to GC/MS based analysis, this is performed during all terrestrial experiments and serves the purpose of finding the needed correlations between the assays and the on-line reading signal changes indicating the progress of the reaction.

Telemetry Subsystem. Provided by NASA as part of the Sounding Rocket, Space Shuttle and Spacelab.

For the Sounding Rocket and Space Shuttle tests the following channels are required:

- seven analog channels for terrestrial receiving stations for T, P, pH, DO, ORP and two optional channels (maximum),
 - six contact closure channels (digital) to actuate pump (on/off), three RV valves, one gas/air valve plus one optional valve (maximum).
-

For the Spacelab tests an electronic module containing the actuators for pump and valve operations will be designed. Telemetry System performs the transmission of directly acquired and computer processed signals to the terrestrial receiving station.

Computer Interface, Computer Peripherals. -
1-G System contains:

- Telemetry Receiving - Computer Interface Subsystem,
- Direct interface with 1-G Reactor Chamber sensors having an identical number of analog channels with those used for the Sounding Rocket, Space Shuttle Spacelab Reactor Chambers,
- Digital Computer with minimum 64K (16-bit word length) core memory (processing time: 900 nsec), two 1.2 million (16-bit word length) disks (drivers and controllers), tape recorder with about 1.0 million (16-bit word length) capacity, teletype (TTY) to introduce off-line information (e.g. GC/MS data) into the computer.

0-G System (for Spacelab only; optional for Space Shuttle) contains essentially the same capability as specified for 1-G system. Interface channel number will be augmented, however, if interactive control for the pilot-plant scale Space Bioprocessing System is developed.

Multichannel Recorder(s). Essential for recording of all acquired process variables (including GC/MS data) regardless they are obtained from 1-G or 0-G experiments. Multichannel recorder (9 channels) per Reactor unit is used during all terrestrial experiments and for the case of the Spacelab experiments

Computer Software. - is based on FORTRAN IV or equivalent scientific language for processing

statistical information. The specific programs include:

1. Real-Time Executive,
2. Data Acquisition (on-line or with TTY),
3. Noise Filtering,
4. Statistical Analysis,
5. Signal Transmission,
6. Data Logging and Retrieval, as well as
7. Data Plotting Subprograms.

In a later developed form (for Spacelab operation), the program will incorporate a control subprogram which is based on the process status and governs the coordinated operation of the bioreactor and recovery-purification as well as the auxiliary subsystems (see page 146).

7.3.5. INTEGRATION OF SB-1 WITH RECOVERY APPARATUS

Figure 33 presents a schematic for interconnection of the bioreactor and recovery apparatus. The final recovery-purification unit is an electrophoretic apparatus (EFO). Samples for recovery can be obtained via dialysis system 7 or directly from the liquid circulation pipeline 2. The dialysis system supplies a cell-free liquid containing a relatively low product concentration. A direct sample system provides the culture liquid containing all of its constituents. Because of the anticipated differences in the kinetics of biosynthesis, and product separation and purification, a "buffer subsystem" 9 is placed within SB-1. In this case the buffer subsystem collects culture liquid during the recovery-purification operation. Discharging culture liquid onto the EFO system is regulated by the progress of the recovery-purification step. It is necessary to develop a sensorial system with a capability

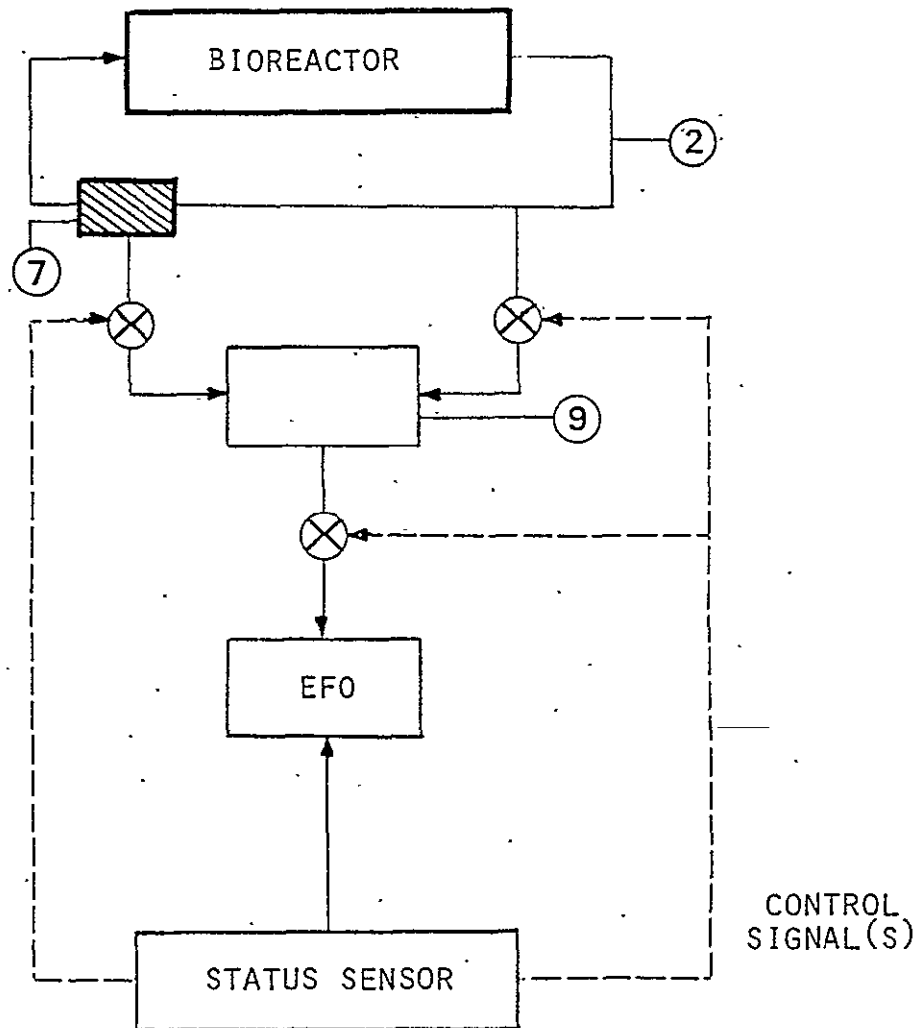

FIGURE 33.
INTEGRATION OF SB-1 WITH RECOVERY
APPARATUS

to detect the status of the recovery-purification process performed by the EFO apparatus. This provides control signals which operate the valves discharging samples into the "buffer subsystem" and into the EFO apparatus. The necessary sensorial system which identifies the status of recovery-purification process is not defined at this time.

Buffer subsystem vessel 9 is made of 316 SS and has connection previously described in Chapter 7.3.3. (p. 132 and Figures 30-31). The subsystem can be modified to serve as an ultrafiltration apparatus to concentrate the target compound prior to purification.

7.3.6. COORDINATED OPERATION OF SUBSYSTEMS

According to the principle of systems integrity the operation of biosynthesis, recovery and support subsystems will be coordinated. Figure 34 shows a concept of the systems operation control. This assumes identification of the process status both for the biosynthesis and for the recovery part of the system. As was shown, the biosynthesis stages and its kinetics can be analyzed and controlled on-line, in real time. This part of the process is considered, however, to be the most complex, exposed to many unexpected disturbances. In the case of product recovery (dialysis and EFO) liquid flow rates and material concentration are considered to be the pivotal variables.

Information on the status of both processes is fed into the controllers of the process support system. This assures the proper rates of gas and liquid removal and purification as well as defines the availability and supply of utilities. It is well known that the microbiological processes are water extensive. Therefore, particular care must be exercised to assure the proper water recycling schedules.

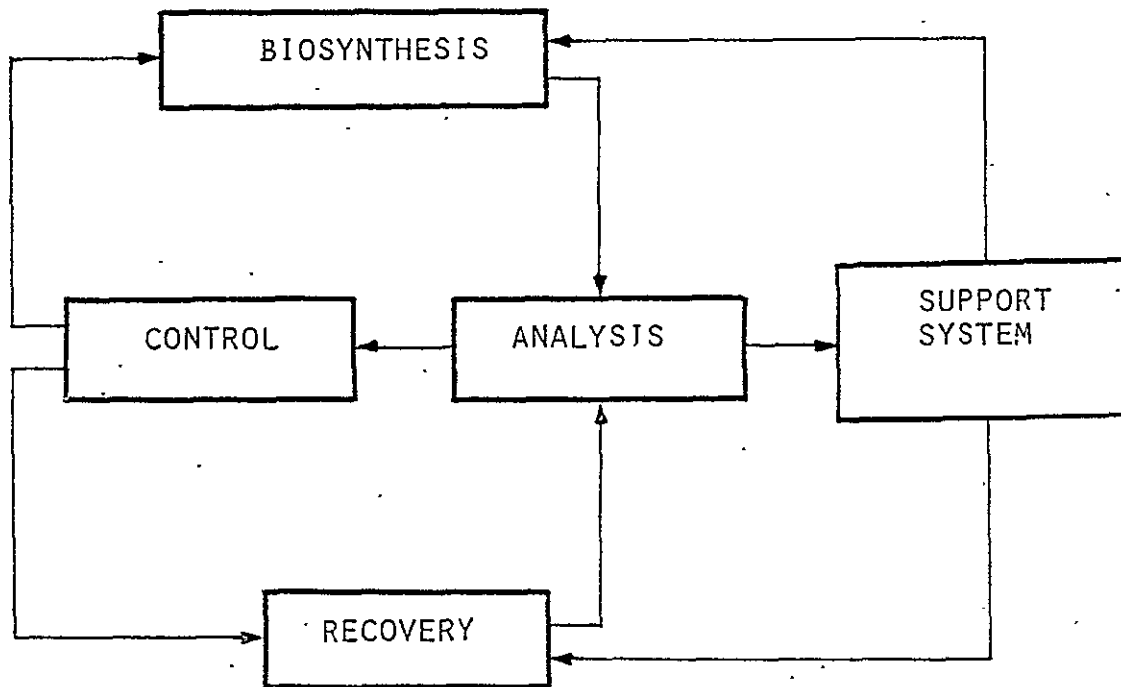

FIGURE 34.

CONCEPT OF SYSTEMS OPERATION CONTROL

The task of construction of a system with such a complexity and the payload constraints require application of microprocessors for process control purposes. These are programmed according to findings while using minicomputers in process analysis and controls of biosynthesis and recovery systems during the test stages. The development of this coordinated function and the necessary hardware is a subtask to be solved in the second and third stages of the project and experimentally tried in the fourth stage in parallel experiments under 1-G and 0-G conditions.

7.3.7. SPECIFICATIONS

According to the aforementioned constraints, three prototypes of the Space Bioprocessing System are considered, namely:

- 1) 1-G Experimental Model, consisting of all elements of the Basic Bioreactor System (SB1) + On-Line Instrumentation + EFO Apparatus, interfaced with an on-line operating minicomputer. This vessel has 500 cm³ total and 375 cm³ working capacity and is equipped with provisions to take samples for wet-chemical analysis.

This 1-GEM serves the purpose of experimental definition of the optimal conditions for model reactions as well as animal cell-culture studies for production of peptide-protein type compounds of scientific-medical importance. Dialysis, buffer-subsystem (ultrafiltration apparatus) and EFO are used to define the conditions for product recovery. This apparatus will be later augmented to incorporate auxiliary subsystems for byproduct and waste recovery.

Major specifications of this 1-GEM prototype are given on Table XX (with the exception of data acquisition, data processing and logging electronics as well as the wet-chemical analytical apparatus).

TABLE XX

PRELIMINARY SPECIFICATIONS FOR SPACE BIOPROCESSING SYSTEM

SUBSYSTEM	DIMENSION (H / W / D) (cm)	(FIRST PROTOTYPE) (MAXIMUM SIZES)		SPECIFIC CONDITIONS
		WEIGHT (KG)	POWER REQ'D V.A.	
I BIOREACTOR (RC, PE, PU, DIA, RV*)	43/45/23	15	500	STERILIZATION WITH ETHYLENE- OXIDE-CO ₂ AND/OR STEAM (ON THE GROUND)
PH ANALYZER	17/24/17	1	50	
DO ANALYZER	17/24/17	1	50	
ORP ANALYZER	17/24/17	1	50	
T CONTROLLER	10/20/10	2.0	75	
P CONTROLLER	10/10/10	0.7	50	
BUFFER SUBSYSTEM	10/5/15	1	0	
II EFO APPARATUS	C.F. NASA'S A.O. NO. OA-76-02			NEEDED FOR 1-G CONDITIONS FROM THE BEGINNING OF PROJECT AND FOR 0-G CONDITIONS IN SPACELAB (SPACE-SHUTTLE OPTIONAL)

* REAGENT VESSELS OF 100 CM³ ARE ASSUMED.

1-GEM or its modified versions will operate throughout the four stages of the project.

- 2) Sounding Rocket - Space Shuttle Prototype (SRSSP) which is a size reduced version of the SB-1 part of 1-GEM ($RC1 = 100 \text{ cm}^3$) to meet the space and payload constraints of the Sounding Rocket (133). Only minimum electronics is utilized which is essential to perform model experiments of relatively short duration in order to gain information on the effect of microgravity on cellular and subcellular activities as well as experimentally determine the performance characteristics of the hardware elements (especially T and P controllers) exposed to launch, orbiting and return conditions.

The Space Shuttle Prototype version of SRSSP may be a handcarried model of SB1 with an electronic plug-in capability to the vehicle's telemetry system.

- 3) Spacelab Bioprocessing Prototype (SBP)
A pilot-plant unit can be designed for the Spacelab with a working capacity of 10 L. Equipped with the above described subsystems for BS-1 as well as with on-line process analyzers and controllers its estimated dimensions are:

80 cm height, 100 cm width, 60 cm depth with estimated weight of 120 kg and total energy requirement of 1.5 KW.

This equipment still can be placed on a workbench for convenient operation. Services (air, N_2 , O_2 , CO_2 , vacuum, electricity) will be obtained from Spacelab's supply.

In addition to this unit will be the EFO apparatus. Data acquisition, information

processing logging apparatus as well as any necessary wet-chemical analytical units are additional payload constraints.

As an alternative, a modified version of 1-GEM can be used in the Spacelab. Size and payload constraints (with the exception of computer electronics, peripherals and wet-chemical analytical apparatus) are estimated in Table XX (p. 149).

In all cases minimum two "identical twin" units are built; one for 1-G (control) and one for 0-G experiments.

Characteristics of an EFO apparatus are described by NASA's Announcement of Opportunity A.O. No. OA-76-02 (133). This is a continuous flow electrophoresis device, having a 5 mm x 5 cm cross section and a high flow rate to increase the processed volume of experimental sample. It is anticipated that this model will go through various modifications in the future. It is noted that only in Space Shuttle operation (Stage 3) do we visualize an attempt to operate SB1 and EFO together (depending on the payload possibilities).

Telemetry, computer interface, computer peripheral subsystems and multichannel recorders are not described. It is understood that the individual vehicles have one or more of these equipment (133, 134, 135) aboard.

The wet-chemical analytical, GC/MS systems are not specified. Specs related to these apparatus can be given only after the evaluation of the Stage 1 experiments. Also, it is anticipated that commercial GC/MS analytical apparatus will undergo drastic size and weight reductions in the next several years.

7.4. EXAMPLE OF EXPERIMENTING THE EFFECT OF MICROGRAVITY ON BIOCHEMICAL PROCESS

This part of the Report describes an example to conduct an experiment which attempts 1) to determine the effect of microgravity conditions on biochemical process and 2) study the performance characteristics of the prototype SB-1 exposed to conditions existing during launch, orbiting and return of the spacecraft.

For the experiment a ballistic Sounding Rocket flight is used where 5-6 minutes of near weightlessness exists during the coasting phase of the flight (133).

The experiment is conducted in the Stage 2 of Space Bioprocessing project after a) the SB-1 prototype is built and experimentally tried under terrestrial conditions, b) experimental conditions are defined for a selected model experiment. These two factors are considered as technical milestones in the Space Bioprocessing program achieved in Stage 1 of the project.

7.4.1. MODEL EXPERIMENT

For the sake of demonstration of the operation of SB-1 and anticipated results, conversion of D-glucose into D-gluconic acid by means of glucose oxidase (c.f. Chapter 5) is selected. The experiment will be conducted in a working SB-1 model using a ballistic Sounding Rocket during its coasting phase of the flight.

7.4.2. DESCRIPTION OF THE EXPERIMENT

Two, identical twin, working prototypes of SB-1 (SB-1/1, SB-1/2) equipped with stainless steel

reaction chamber (RC-1) T, P, pH, DO sensors/ amplifiers, pump, liquid circulation pipe, two gas cylinders ((O₂) (N₂)) and one reagent addition vessel will be used. Temperature and pressure in the reaction chamber will be maintained by controllers. Because of the size constraints for a Black Brant VC Vehicle, a 40 x 40 cm size model will be constructed requiring estimated total 0.75 KW for operation. RC-1/1 is secured into its place in the vehicle. In case of necessity, insulation is applied to compensate wide temperature changes in the vehicle's compartment. RC-1/2 is used for simultaneous control experiment under 1-G conditions.

Required telemetry channels for RC-1/1 are: 4 analog channels for (T, P, pH, DO measurement), three digital channels to actuate pump (ON/OFF), gas input valve, reagent input valve upon ground command. Further, all information related to compartment temperature, pressure, acoustic, vibration and longitudinal shock levels as well as acceleration values are requested by telemetry as part of the experimental conditions before and during the flight. All information are introduced into a ground based computer programmed for on-line, real time data acquisition, information processing and statistical evaluation.

Reaction chambers are filled with specified volume of aqueous solution of buffer salts and D-glucose, saturated with oxygen. Strength of the buffer allows changes in pH, starting concentration of D-glucose permits the completion of reaction in 5 minutes. One reagent vessel contains purified glucose oxidase with a total activity to complete the reaction in five minutes. These concentration values are determined in particular stability of glucose oxidase in aqueous solution for the waiting period before launching by ground based experiments during Stage 1 of the project. Enzyme solution is sterilized by

means of filtration using a 0.22 filter and introduced into the presterilized RV pressurized with N₂, then attached to RC-1 by means of quickfit disconnect.

Reaching the coasting flight condition (determined by the acceleration value communicated by telemetry) both models are activated by manual command starting the liquid circulation, temperature and pressure controller and introducing the enzyme into the reaction chamber. It is noted here, that it is advantageous to set and maintain the T and P conditions before and during the launch phase to avoid time loss for establishing these environmental factors during the coasting flight-stabilization phase of the flight. Operating characteristics of SB-1 must be established in Stage 1 of the project with specific respect to heat-up, temperature stabilization, as well as the interactive changes in O₂/N₂ gas addition. During the reaction, addition of O₂ is terminated and N₂ introduction is performed only to compensate pressure changes due to the pressurized introduction of enzyme into the reaction chamber as well as the possible pressure changes created by the pump.

Anticipated environmental conditions are: T = 30° C, P = 1.1 + ATM (preliminary estimates).

According to the described reaction mechanism of enzymatic conversion of D-glucose to D-gluconic acid (see Chapter 5) the reaction can be followed by the changes in pH and DO level. In Stage 1 the kinetics are defined, the model for 1-G conditions is established and introduced into the computer as part of the data processing program. Also, models for deviations are developed considering uninfluenced, improved, or worse kinetic conditions in microgravity. By comparing the changes in pH and DO values taking place simultaneously during the parallel experiments,

statistical analysis can be performed to define the effect of microgravity on the reaction kinetics. According to Equations /3/15/ and /16/21/, it is anticipated that changes in DO level will reflect S - L conditions, whereas changes in pH will indicate the L - GA transition. Shape and slopes of these two different process status indicator curves will reflect the kinetic constraints from which the reaction mechanism may also be determined.

In another case we visualize a DO (or ORP) probe based kinetic study with varying S and fixed E_0 concentration of fixed T and pH conditions (strong buffer). Analysis of the results is performed on the basis of steady-state velocity measurements where the steady-state turnover data for comparison can be obtained as tangents to the DO (ORP) electrode readout and plotted in a double reciprocal mode as E_T / v versus $1/S$ or $1/DO$ unit.

After the reentry and recovery of the vehicle, SB-1/1 is returned for investigations which include:

- physical examination of the hardware,
- wet-chemical analysis of the reagents (E, S, P, intermediate),
- rerun of the experiment with the identical twin bioreactor.

It is understood that the Sounding Rocket experiments are primarily intended to develop experimental techniques, accumulate operational experience, and identify the effects that the weightlessness imposes on material conditions and reactions (133). After defining and performing the necessary modifications the Space Bioreactor will be able to serve the purpose of various bioprocessing experiments with specific emphasis on biosynthesis (bioconversion) of materials under microgravity conditions. As it was stated

previously, we believe, this type of experiment also enables the users to perform quality control (performance) tests on newly developed bioprocessing equipment.

The above described example serves the purpose of illustrating the type of experiments intended to perform during the project implementation. It is anticipated that the Space Shuttle offers extended time for conducting microbiology oriented experiments using more sophisticated equipment, whereas Spacelab makes experiments possible with animal cells using pilot-plant type equipment where both biosynthesis and recovery can be simultaneously tried along with application of novel control techniques for the entire Space Bioprocessing System. Needless to say, the prerequisite of the Spacelab experiment is a relentless implementation of ground based experiments which lead to better understanding of animal cell cultures, biosynthesis characteristics and development of separation-purification techniques for target compounds of social-economic significance.

8. CONCLUSIONS AND RECOMMENDATIONS

8.1. CONCLUSIONS

8.1.1. BIOPROCESSING IN SPACE

According to its objectives, this report analyzes the conditions and possibilities with respect to bioprocessing of organic materials in Space. Statements made are based on the observations described in Chapters 3-7, and serve the purpose of an executive summary of our findings.

Bioprocessing of organic materials in Space covers essentially two major operations, namely:

- 1). Biosynthesis of organic compounds, and
-

2) Recovery of said compounds in microgravity environment.

Biosynthesis of organic compounds requires an interaction of living cells with substrates. The cells can be of microbiological, plant or animal origin, depending on the type of compound to be produced. Living cells may be substituted by subcellular elements (e.g. enzymes). In order to achieve the potential maximum level of cell-substrate interaction optimum environmental conditions for the bioreactions must be established and maintained.

Recovery of the organic compounds from the reaction mixture (culture liquid) requires complex physical, physico-chemical or chemical operations. These result in separation of the target compound(s) from the contaminating materials. This part of space bioprocessing also requires precisely defined technological conditions.

Implementation of Space Bioprocessing makes it necessary to design, construct and operate an equipment which has the capability to carry out the biosynthesis and recovery functions under various environmental conditions. In the early stage of the project the equipment is small, however, it has all the necessary instrumentation for the experimental definition of the optimum operating conditions, and to analyze the effect of microgravity conditions on cellular activities. It also has the capability to be scaled-up to production size should the microgravity environment offer advantages for bioprocessing organic compounds.

In order to implement the project, a stepwise operation is needed starting from basic experiments resulting in better understanding of the effect of microgravity on cellular or subcellular (enzymatic) activities, then implementing a manufacturing technology to produce compounds of social significance.

8.1.2. PROBLEMS OF BIOPROCESSING UNDER TERRESTRIAL CONDITIONS

According to experience accumulated in the fermentation industry and in biochemical engineering during the past 30 years, certain factors are considered as reaction rate limiting steps for culturing microbial, plant or animal cells:

1. Mass transfer into or from cells. In particular, the transfer of oxygen from air to the cell wall (or membrane) and removal of toxic byproducts (e.g. CO₂) from the culture liquid.
2. Transfer of compounds through membranes. This is related to all cells and membranes as well as artificial membranes.
3. Gravity induced sedimentation of solids, which - in the case of cells - reduces the accessibility of substrates to the cell surface. This results in a tendency of cells a) to float on the surface of a culture liquid, b) to attach to solid surface, or c) to settle to the bottom of culture vessel. In the first two cases, a two-dimensional growth (i.e. cell arrangement on a surface (cm²)) takes place which significantly reduces the product formation rate as well as the amount of material produced. In the third case, the lack of oxygen alters the entire metabolism (aerobic-anaerobic transition), which may lead to cessation of biosynthesis of the target compound(s).

Fermentation industry tried to overcome these difficulties by means of mixing the three (gas-liquid-solid) phases. As a result, the cells are suspended in the liquid and a three-dimensional growth (i.e. distribution of cells in cm³) takes place. This method has been successful for microbial cell cultures and significantly increased their productivity.

However, animal cells which need attachment to surface and are sensitive to shear stresses and surface tension changes caused by agitation and introduction of gas bubbles, could only be cultured in surface cultures (cm^2). Although growth in suspension cultures of certain animal cell lines has been achieved in many cases the cell differentiation might create problems when attempting to maintain permanent animal cell cultures for production of organic compounds.

Recovery of compounds from culture liquids under terrestrial conditions have to overcome gravity induced weight, liquid flow conditions, solid-liquid as well as liquid-liquid separation problems. These are generally solved using filtration and/or centrifugation techniques.

8.1.3. EFFECT OF MICROGRAVITY CONDITIONS ON BIOLOGICAL ACTIVITIES AND MATERIAL HANDLING

The available literature revealed unusual behaviour of gases and liquids under microgravity conditions. In particular, the following possibilities are of interest from the viewpoint of culturing cells or using subcellular elements for biosynthesis in Space

1. Enhanced mass transfer by diffusion,
2. Improved membrane permeabilities,
3. Lack of (gravity induced) sedimentation,
4. Lack of gradient density separation of immiscible gases and liquids.

These factors can contribute a) to maintain cells in suspended form even under mildly agitated conditions (decreasing the shear stress), b) improve transport of materials through natural and artificial membranes. These physical effects influence the O_2 transfer and improve the possibility for removal of toxic byproducts.

and the target compounds from the culture liquid. This may enhance metabolic activity resulting in increased growth and product formation rates. Suspension type (cm^3) growth of nondifferentiated and differentiated cells of animal origin also may be possible in the absence of gravity induced sedimentation conditions.

Available experimental data on microbiological, plant and animal cell growth characteristics under microgravity conditions revealed some data indicating the possibility of enhanced metabolic activity manifested in faster cellular growth of Salmonella typhimurium (13) and increased respiratory activity of Spirodella polyrhiza (20). Also, three-dimension growth of otherwise anchorage dependent animal cells was observable in altered environmental conditions (101).

With regard to recovery of organic materials from contaminating compounds under microgravity conditions the electrophoresis technique (EFO) has proven to be a possible technique. Using EFO it was possible to separate living cells under weightless conditions. Specifically, living kidney cells with enhanced urokinase activity were obtainable from a mixture of kidney cells. Since EFO is widely used in preparative biochemistry for separation-purification of certain organic compounds, this technique could be utilized as part of bioprocessing procedures under microgravity conditions. Application of such a technique drastically simplifies the otherwise complex separation procedures used under gravity induced terrestrial conditions.

Comparing the experimental data as well as achievements using microgravity conditions with regard to processing inorganic materials in space, our current knowledge of the direct or indirect effect of microgravity on cellular and subcellular activity is considered to be woefully scarce. Data available

are either of a qualitative nature or are discounted because of the lack of establishment of proper environmental conditions excluding all factors but the microgravity for influencing the process. The available data, however, hint at advantages for space which can not be overlooked if novel bio-processing technologies are considered in a modern society.

8.1.4. DETERMINATION OF EFFECT OF SPACE CONDITIONS ON BIOLOGICAL MECHANISMS

In order to obtain unequivocal answer to the question: "Does the space environment, especially the microgravity, exercise direct or indirect effect on cellular mechanism?" it is essential to design and conduct a series of experiments using the Space Shuttle and Spacelab opportunities for this purpose. A model process was selected on the basis of various criteria (p. 15). The process is the formation of gluconic acid from D-glucose or from an intermediate (D-glucono-lactone). It can be performed by organic chemical, enzymatic means as well as using fast growing, oxygen requiring microbial cells.

As was demonstrated in Chapter 5, the reaction mechanism and its kinetics are well known especially in the case of enzyme facilitated conversion of D-glucose into gluconic acid. The glucose oxidase based experiments, therefore, can serve as starting points to obtain statistically adequate data which demonstrate the direct or indirect effect of microgravity on biological processes.

The ability to perform the D-glucose-gluconic acid conversion in three different ways offers a unique opportunity to search out unusual effects of microgravity conditions on reaction mechanisms. In particular, the transfer of oxygen to the cells and to the enzyme-substrate complex can be accurately investigated.

The reaction kinetics can be followed with direct reading sensors such as pH and dissolved oxygen probes. These sensors generate electronic signals proportional to concentration changes of the reactants. Signals can be transmitted to the computer which will be programmed to compare data of simultaneously performed experiments in 1-G and microgravity conditions. Data reflect the effect of microgravity conditions on the reaction mechanism and its kinetics.

The product of the reactions diffuses through membranes and is recoverable by electrophoresis which in fact offers an opportunity to test the performance characteristics of the entire bioprocessing system. It is also expected that one of the selected D-glucose-gluconic acid conversion mechanisms can serve as a quality control procedure to determine the performance of prototypes or their modified versions. Also, it serves the experimental basis for scale-up studies.

This test experiment is considered as an essential element in definition of the direct or indirect effect of microgravity on chemical and biological processes. We believe that this type of study is an inevitable step in the future space-biology oriented research. Data obtained with this means will reveal information of practical importance relative to the following areas:

- 1) Space based chemical industry,
 - 2) Space based biochemical-fermentation industry,
 - 3) Biological waste treatment in space colonies,
 - 4) Reactor-control system design for the above mentioned applications.
-

8.1.5. PRODUCTION OF ORGANIC COMPOUNDS IN THE SPACE

In view of recent and future developments in biochemical engineering, cell culture technology as well as in the pharmaceutical industry, the following aspects of space bioprocessing must be considered:

1. There are organic compounds of large social and scientific importance, terrestrial commercial production technology of which is far less developed compared to the opportunities revealed by scientific and technical experiments. A study comparing the production technologies, price structures of some representative compounds (see Chapters 4 and 6) revealed that the least developed production techniques as well as the highest unit prices can be found in the case of peptide type hormones. Any improvement in the production technology makes a broader application oriented research and a wider use possible. In addition, improved technology reduces the price of compounds resulting in less expensive medical treatment.
2. The study revealed that certain peptide type hormones can be produced by means of in vitro culturing of animal cells, and recovering them by means of electrophoretic techniques.
3. Experimental data indicate that the amount of hormones produced by animal cells is in correlation with the number of cells. Because of the anchorage dependency, however, hormone producing animal cells are generally growing in two dimension (cm^2) (tissue) cultures. This limits the cell-number and reduces the efficiency of environmental control operations.

If - as the qualitative results on cell growth in space indicate - microgravity enhances the metabolic

activity and makes three-dimensional cell growth possible, the hormone production may significantly increase. A projected maximum hormone secretion rate at a maximum cell density ($\approx 10^8$ cells/cm³) may yield about 2G hormone per liter in 24 hours (25,26). Comparing this with the reported yield of ACTH (12 mg per kg pituitary gland (Table XV)) this is 166 fold increase above the currently existing output.

There are certain technologies developed under terrestrial conditions which already can increase the cell number in case of tissue cultures. These are the capillary cultures as well as the suspension-perfusion technique. Also, a combination of tissue and suspension culture seems to be applicable using microcarriers to support the growth of anchorage dependent cells. Application of such technologies with membrane separation of the product and using electrophoresis for its purification is considered a novel technology itself - efficiency of which ought to be investigated comparing the yields with those obtained using the current hormone manufacturing technologies.

4. Novel techniques developed to culture animal cells with the capability to product peptide-protein type hormones and recover them using membrane filtration as well as electrophoresis can be adapted to manufacture other peptides and - depending on the cut-off value of the isolation membranes - for proteins in the range of lower molecular weight (50,000).
 5. The study detected further advantages in selection of hormones as primary target compounds for space bioprocessing. Mode of action of hormones requires their administration into the body in extremely low quantities. Therefore, a bioprocessing unit of relatively small size can be used for production purposes, should the early experiments indicate advantages in enhanced metabolic activity, increased
-

growth rate, facilitated membrane separation and/or electrophoretical purification. Although the absolute amount of hormones manufactured in 1974 (our latest available statistical information) dipped 15 per cent from the amount produced in 1971, the value of the products showed a four fold increase. This indicates a shift in production in the direction of more valuable hormones (Table XVII) which interests for improved production technologies.

6. In the past years there has been increasing research devoted to the extrahormonal effects of certain hormones. In particular, findings that ACTH can reduce anxiety or improve memory are of significance. Although these works are in the early stage and the interactive effects of hormones (overdose!) can not be ignored, any breakthrough requires process technology to manufacture peptide type compounds in substantial quantity. Cell culture techniques geared to produce hormones are considered as prime candidates for such an enterprise.
7. Selection of the hormones was based on the social need, scientific-medical significance, availability, production technologies, current and future production trends and prices (Chapter 6). Accordingly, the following hormones are recommended for experimental trial for Space Bioprocessing:
 - Human Growth Hormone (HGH),
 - Human Chorionic Gonadotropin Hormone (HCG),
 - Adrenocorticotropic Hormone (ACTH), and
 - Thyroxine (T₄).

Depending on the funds available, one or more of the recommended substances can be experimentally tried for Space bioprocessing. It is noted, however, that in all cases the necessary equipment must have the capability to be utilized in microgravity environ

8.1.6. BIOPROCESSING EQUIPMENT

Regarding the unique material handling conditions in the Space, the proposed bioprocessing equipment consists of three major elements, namely:

- Bioreactor,
- Recovery subsystem, and
- Auxiliary equipment.

The bioreactor design is different from the conventional fermentor and tissue culture apparatus used so far under 1-G conditions, however, elements of the reactor were already successfully tried under terrestrial conditions. The system is based on a tubular loop configuration where the only moving part is a liquid circulation pump. Interchangeability of the system elements makes it possible to perform chemical, biochemical reactions as well as culturing microbial, plant or animal cells either on monolayer or in suspension cultures. Instrumentation provides on-line, real time analysis of the key process variables such as temperature, pressure, pH, dissolved oxygen concentration, oxidation-reduction potential, analysis of substrate concentration and product formation rates. Construction of several models seems necessary, one complete bioprocessing apparatus for terrestrial studies, and other reduced size or simplified models in order to cope with the payload constraints of the various space vehicles. Depending on the observations obtained during the experiments, a prototype up to 10 liter scale is proposed for extensive study of space bioprocessing techniques during Spacelab flights.

The recovery equipment consists of dialysis/ultra-filtration membranes and an electrophoretic apparatus. Experiments with this prototype can be separately performed (by an other experimental group) parallel

with the biochemical, cell-culture experiments. However, it is desirable to operate one l-G unit with an integrated capability to perform both biosynthesis and recovery-purification operations.

Experimental data are transmitted into a mini-computer for the purpose of statistical analysis of simultaneous experiments conducted in l-G (control) and O-G environment. A specific computer program compares the effects of l-G and O-G on the cellular and subcellular activities performed under specified environmental conditions.

Since the biological processes are sensitive to gas exchange, care must be exercised to establish and maintain conditions which influence gas transfers. In particular, precise control of temperature, pressure and gas introduction are of utmost importance through the whole project implementation.

8.1.7. PROJECT IMPLEMENTATION

Four stages of the project implementation are visualized. In Stage 1 terrestrial (l-G) experiments are implemented to define the performance characteristics of the selected prototype, establish the optimum experimental conditions for the model experiments and develop technology for the production of at least one (peptide) hormone. This part of the study is continued throughout the implementation of the whole project.

In Stage 2 Sounding Rocket experiments gather data on the effect of microenvironment on selected model reaction(s). In this case, experiments of short duration (e.g. enzymatically catalyzed conversion of D-glucose to D-gluconic acid) can be implemented, however, the statistical analysis will provide enough

information to see significant differences (if they exist) in the reaction kinetics as influenced by 1-G and 0-G conditions.

In Stage 3 Space Shuttle experiments extend the scope of investigations using microbial or mammalian cell cultures for product biosynthesis. Terrestrial studies on hormone production may make it possible to perform a relatively short duration hormone biosynthesis experiment on early flight opportunities. Also, (depending on the payload) the first integrated biosynthesis-EFO experiment can be performed.

In Stage 4 experiments in the Spacelab conclude the project. These include long duration hormone biosynthesis, recovery-purification processes coupled with byproduct (CO₂) recovery and waste (H₂O) recycling operations. Also, fully automatized operation of the Space Bioprocessing System will be implemented. The product will be returned to Earth and used either for scientific or for medical purposes.

Total anticipated duration of the project is 5+ years. Scale-up of the successful operation is anticipated subsequent to the conclusion of this project. However the information gathered during this period is considered to be sufficient 1) to define the advantages of the microgravity on cellular and subcellular activities and 2) design (micro) biological or chemical waste recycling systems for space colonies.

The structure of the project requires ground based continuous experiments related to the following areas:

- 1) Definition and statistical analysis of model experiment kinetics,
 - 2) Development of animal cell culture based on hormone biosynthesis techniques,
-

-
- 3) Dialysis, ultrafiltration based recovery of peptide (protein) type compounds,
 - 4) Electrophoretic purification of peptide (protein) type compounds,
 - 5) Reactor-subsystem design,
 - 6) Interactive computer control technique development,
 - 7) Application experiments with peptide (protein) type hormones.

Each area has to have an orientation and the researchers must have a deep understanding toward the application of the results in space bioprocessin

8.1.8. POTENTIAL SPINOFFS

In addition to the definition of effect of space environment on cellular and subcellular activities as well as the potential application for production biological materials in space, the following spinoff for terrestrial applications are anticipated:

1. Bioreactor vessel sterilization technology with ethylenoxide,
2. Tubular loop fermentor development (reactor design),
3. Complex computer control technology for biological processes (systems, process dynamics and control),
4. Transport of molecules through membranes (artificial organ development),
5. Separation processes and techniques for peptide-protein type compounds,
6. Waste water treatment.

8.1.9. SUMMARY OF CONCLUSIONS

Reviewing the studies relative to the potentials in processing biological materials (19, 103, 130), we

have a consensus with other researchers that,

- 1) There is a possibility to achieve better results processing certain materials in the Space environment by biological means if the microgravity enhances the metabolic activities and/or improves the recovery techniques,
 - 2) Only compounds of high efficacy or social importance can be considered as prime candidates for first trial. These compounds must have high production cost, because of problems in availability of raw material or complex manufacturing technology,
 - 3) There are compounds which fulfill the criteria mentioned in point 2) above. In particular, peptide type hormones are mentioned by us, vaccines by other researchers. Since both materials are of peptide-protein nature, unique technology developed for the production of one can be adapted to other. It is noted, however, that the "amplification" type mode of action of hormones as well as the most recent developments in extrahormonal effect of certain (brain) peptides shift the balance in favour of hormones, at least for the first trial.
 - 4) There is a "vicious circle" existing relative to the space bioprocessing: a) no significant interest is observed from the scientific and business communities because of the lack of evidences demonstrating the advantages of the microgravity environment, b) NASA is reluctant to push the subject strongly because of the lack of interest.
-

It is our opinion that only NASA can break this circle by the implementation of the proposed project. The challenge is given and the advantages are enormous making positive contributions in better understanding of biological processes.

8.2. RECOMMENDATIONS

8.2.1. PROJECT OBJECTIVES

It is recommended that NASA institutes a coordinated Space Bioprocessing Program with the objective to develop production technologies for biosynthesis, recovery/purification of biologically active compounds in microgravity.

An additional objective of the project is to obtain information on cellular and subcellular metabolic activities as influenced by space environment in particular, by microgravity. This information can be used in various fields of applied biological sciences.

8.2.2. PROJECT IMPLEMENTATION

It is recommended that the project would be implemented by carrying out a series of experiments in four major stages under terrestrial and space conditions.

The experiments are divided into three general tasks:

1. Model experiments to unequivocally define the effect of microgravity on cellular and/or subcellular metabolic activities,
 2. Development of at least one technology to manufacture a peptide type hormone of large social importance with a possibility to reduce the current manufacturing costs.
-

-
3. Design, construct and demonstrate equipment for the above mentioned task implementation.

All tasks are worked out at first on Earth and experimentally tried under microgravity conditions using the opportunities of Sounding Rocket, Space Shuttle and Spacelab flights.

Tasks are implemented by a number of specialist team belonging essentially to four major disciplines:

- 1) Applied Biochemistry,
- 2) Cell-Biology - Tissue Culture Techniques,
- 3) Biochemical Engineering,
- 4) Aerospace Engineering.

A Steering Committee should be organized which reviews the development of the tasks and assists NASA in organization of the project, recommending priorities, etc. Members of the committee are recruited from scientific, engineering and management members of the following disciplines:

- 1) Applied Biochemistry,
- 2) Pharmacology,
- 3) Cell Biology,
- 4) Endocrinology,
- 5) Biochemical Engineering,
- 6) Aerospace Engineering.

The following centers are recommended for conducting studies relative to the project or act as members of the Steering Committee:

- 1) Applied Biochemistry
 1. Kinetics of Model Systems

Open.

2. Recovery of Peptides and Proteins (EFO)

Lehigh University, Sinclair Laboratory #7
Bethlehem, Pa. 18015
Dr. HENRY LEIDHEISER, JR.

2) Pharmacology

University of Wisconsin Madison
Center for Health Sciences
School of Pharmacy
425 North Charter Street
Madison, Wisconsin 53706
Prof. DAVID PERLMAN

3) Cell Biology - Tissue Culture

W. Alton Jones Cell Science Center
P. O. Box 631
Lake Placid, New York 12946
Dr. DONALD K. DOUGALL

4) Endocrinology (Hormone Production)

Harvard School of Dental Medicine
Department of Pharmacology
Harvard Medical School
Boston, Massachusetts 02115
Dr. A. H. TASHJIAN, JR.

5) Biochemical Engineering

Lehigh University
Dept. of Chemical Engineering
Bethlehem, Pa. 18015
Prof. LEONARD WENZEL

6) Aerospace Engineering

Open.

8.2.3. PROJECT PROMOTION

It is recommended to obtain excellent public relation for the purpose of project promotion and science community awareness from the very beginning of the operation. The following institutions are recommended to be contacted to arrange seminars, round-table discussions, paper presentations during the scientific business meetings which are regularly done by these organizations:

(AMERICAN) PHARMACEUTICAL MANUFACTURERS ASSOCIATION
1155 15th Street, N.W., Washington, D.C. 20005

AMERICAN SOCIETY FOR MICROBIOLOGY (ASM)
1913 I Street, N.W., Washington, D.C. 20006

AMERICAN CHEMICAL SOCIETY (ACS)
1155 16th Street, N.W., Washington, D.C. 20036

AMERICAN INSTITUTE OF CHEMICAL ENGINEERS
345 East 47th Street, New York, N.Y. 10017

SOCIETY FOR INDUSTRIAL MICROBIOLOGY (SIM)
3090 Wisconsin Ave., N.W., Washington, D.C. 20016

Results of the research will be published in periodic issued by these organizations.

REFERENCES

- (1) BIER, M., Prospects for Space Electrophoresis. Colloquium on Bioprocessing in Space, LBJ Space Center, Houston, Texas (March, 1976).
 - (2) BARLOW, G.H., LaVERA, L.S., RUETER, A. and ALLEN, R., Electrophoretic Separation of Human Embryonic Kidney Cells in Space. Colloquium on Bioprocessing in Space, LBJ Space Center, Houston, Texas (March, 1976).
 - (3) BREDT, J.H. and MONTGOMERY, B.O., New Challenges for Industry, Astronautics and Aeronautics. pp. 22-41. (May, 1975).
 - (4) AUDUBERT, R. and deMENDE, S., The Principles of Electrophoresis. The Macmillan Company, New York (1959).
 - (5) MORRIS, C.J.O.R., MORRIS, P., Separation Methods in Biochemistry. Interscience Publishers. New York, (1963).
 - (6) AIBA, S., HUMPHREY, A.E., MILLIS, N.F., Biochemical Engineering. 2nd Edition, University of Tokyo Press (1973).
 - (7) TAYLOR, G.R., Space Microbiology. Ann. Rev. of Microbiology 28, 121 (1974).
 - (8) LORENZ, P.R., ORLOB, G.B. and HEMSNWAY, C.L., Space Life Sci. 1, 431 (1969).
 - (9) BUCHER, H., The Biostack Experiments I and II Aboard Apollo 16 and 17. XVI COSPAR Conference, Konstanz, FRG. (1973).
 - (10) BUCHER, H., HORNECK, G., WOLLENHAUPT, H., TAYLOR, G.R., Apollo 16 Preliminary Science Report. NASA Document Sp-315, pp. 27-1-27-10 (1972).
-

-
- (11) HORNECK, G. FACIUS, R., ENGE, W., BEAUJAN, R., BARTHOLOMA, U.P., Microbial Studies in the Biostack Experiment of Apollo 16 Mission: Germination and Outgrow of Single Bacillus subtilis spores hit by Cosmic HZE Particles. XVI COSPAR Conference, Konstanz, FRG. (1973).
- (12) ZHUKOV-VEREZHNIKOV, N.N. et al., Results of Microbiological and Cytological Investigations Conducted during the flights of Vostok" Type Vehicles. In: Problems in Space Biology. USSR Acad. Sci., Moscow. (English Translation, NASA TT, F-361) (1965).
- (13) MATTONI, T.H.T., Spaceflight Effects and Gamma Radiation Interaction on Growth and Induction of Lysogenic Bacteria. Bioscience 18, 602 (1968).
- (14) MATTONI, T.H.T., KELLER, E.C., Jr., EBERSOLD, W.T., ESERLING, F.A., ROMIG, W.R., The Experiments of Biosatellite II, Saunders, J. (ed.). NASA Document SP-204, 303 (1971).
- (15) ZHUKOV-VEREZHNIKOV, N.N., Experimental Genetic Investigations of Lysogenic Bacteria. Kosm. Issled. 6, 144 (1968).
- (16) SERRES, D., F.J., MILLER, E.R., SMITH, D.B., KONDO, S., BENDER, M.A., Radiat. Res. 39, 436 (1969).
- (17) JORDAN, R.T., Space Processing and Manufacturing. MSCC (October 1969).
- (18) FESTER, D.A., EBERHARDT, R.N., TEGART, J.R., Behavior of Fluids in a Weightless Environment. Colloquium on Bioprocessing in Space. NASA JSC, Houston, Texas. (1976).
-

-
- (19) CUTAIA, A.J., Study of Biogrowth Processing in Space. Report on Contract: NAS8-28085. (1972).
- (20) WARD, C.H., WILKS, S.S., CRAFT, H.L., Effects of Prolonged Near Weightlessness on Growth and Gas Exchange of Photosynthetic Plants. In: Developments in Industrial Microbiology. Vol. 11, p. 276, Am. Inst. of Biological Sci., Washington, D.C. (1970).
- (21) NYIRI, L.K., TOTH, G.M., CHARLES, M., On-Line Measurement of Gas-Exchange Conditions in Fermentation Processes. Biotechnol. Bioeng. 17, 1663 (1975).
- (22) SCHULTZ, J.S., GERHARDT, P., Dialysis Culture of Microorganisms: Design, Theory and Results. Bact. Revs. 33 (1), 1 (1969).
- (23) NYIRI, L., Some Questions of Space Biotechnology. Colloquium on Bioprocessing in Space. NASA JSC. Houston, Texas (1976).
- (24) NYIRI, L.K., KRISHNASWAMI, C.S., Fermentation Process Analysis, Modeling and Optimization. 75th ASM Meeting. Chicago, Ill. (1974).
- (25) POSNER, M., Enzyme Engineering. PYE, E.K., WINGARD, L.B., JR., (eds.). Vol. 2, p. 23. Plenum Press, New York and London (1974).
- (26) HIMMELFARB, P., THAYER, P.S., MARTIN, H.E., Spin Filter Culture: The Propagation of Mammalian Cells in Suspension. Science 164, 555 (1969).
- (27) MERCK Index. 8th Edition. Ed. by Stecher, P.G., MERCK & CO., Inc., Rahway, N.J. (1968).
-

-
- (28) PHILLIPS, G.O., MOODY, G.J., MATTOCK, G.L.,
Radiation Chemistry of Carbohydrates. Part I.
Action of Ionising Radiation on Aqueous Solutions
of D-glucose. J. Chem. Soc., P. 3522 (710) (1958).
- (29) GRANT, P.M., WARD, R.B., Effects of γ -Radiation.
IV. The Degradation of D-glucose in Aqueous
Solution by γ -Irradiation in Vacuo. J. Chem.
Soc., p. 2871 (575) (1959).
- (30) STOLL, A., KUSSMAUL, W., Process for the Oxidation
of Aldose. U.S. Patent 1,648,368 (Nov. 8, 1927).
- (31) HELWIG, E.L., Process for the Electrolytic Oxi-
dation of Aldoses. U.S. Patent 1,937,273
(Nov. 28, 1933).
- (32) FOSTER, A.B., WARDHEIM, S.V., The Action of Bromine-
Sulphuric Acid Mixtures on Methyl α -D-Glucopyranose.
J. Chem. Soc. p. 989 (192) (1957).
- (33) ISBELL, H.S., PIGMAN, W., The Oxidation of Alpha
and Beta Glucose and a Study of Isomeric Forms of
the Sugar in Solution., J. Res. Natl. Bur. Standards
10, 337 (1933).
- (34) BRIGHT, H.J., PORTER, D.J.T., Flavoprotein Oxidases
in the Enzymes. BOYER, P.D. (ed.) 3rd Edition.
p. 421. Academic Press, New York (1975).
- (35) BENTLEY, R., NEUBERGER, A., The Mechanism of the
Action of Notatin.
Biochem. J. 45, 584 (1949).
- (36) BRODIE, A.F., LIPMAN, F., Identification of a
Gluconolactonase. J. Biol. Chem. 212, 677 (1955).
-

-
- (37) COULTHARD, C.E., MICHAELIS, R., SHORT, W.F., SYKES, B., SKRIMSHIRE, G.E.H., STANDFAST, A.F.B., BIRKINSHAW, J.H., RAISTRICK, H., Notatin: An Anti-Bacterial Glucose aerodehydrogenase from Penicillium notatum and Penicillium resticulosum sp. nov. *Biochem. J.* 39, 24 (1945).
- (38) BOYER, P.D., *The Enzymes*. Vol. 12, p. 461. Glucose Oxidase. 3rd Edition. Academic Press, New York (1975).
- (39) CHRISTIE, S.M.H., KENNER, G.W., TODD, A.R. *Nature* 170, 924 (1952) and *J. Chem. Soc.* 46 (1954) in ROBINSON, F.A., *The Vitamin Co-Factors of Enzyme Systems*, Pergamon Press, p. 210 (19).
- (40) SWOBODA, B.E.P., MASSEY, V., On the Reaction of the Glucose Oxidase from Aspergillus niger with Bisulfite. *J. Biol. Chem.* 241, 3409 (1966).
- (41) YOSHIMURA, T., ISEMURA, T., *J. Biochem. (Tokyo)* 69, 839 (1971) in BOYER, P.D. (ed.) *The Enzymes*. Vol. 12, Glucose Oxidase, p. 461. Academic Press, New York (1975).
- (42) SWOBODA, B.E.P., The Relationship between Molecular Conformation and the Binding of Flavin-Adenine Dinucleotide in Glucose Oxidase. *Biochem. Biophys. Acta* 175, 365 (1969).
- (43) PAZUR, J.H., KLEPPE, K., CEPURE, A., A Glucoprotein Structure for Glucose Oxidase from Aspergillus niger. *Arch. Biochem. Biophys.* 111, 351 (1965).
- (44) WORTHINGTON ENZYME MANUAL. Worthington Biochem. Corporation, Freehold, N. J., p. 19 (1972).
- (45) BRIGHT, H.J. and APPLEBY, M., The pH Dependence of the Individual Steps in the Glucose Oxidase Reaction. *J. Biol. Chem.* 244, 3625 (1963).
-

-
- (46) NYIRI, L.K., TOTH, G.M., Unpublished data with MILES' glucose oxidase.
- (47) BENTLEY, R., Glucose Oxidase in the Enzymes, vol. 7. BOYER, P.D., LARDY, A. and MYRBÄCK, (eds.) Academic Press, New York, p. 567 (1963).
- (48) BROUN, G., SELEGNY, E., AVRAMEAS, S., THOMAS, D., Enzymatically Active Membranes: Some Properties of Cellophane Membranes Supporting cross-linked Enzymes. Biochem. Biophys. Acta, 185, 260 (1969).
- (49) WEETALL, H.H., HERSH, L.S., Urease Covalently Coupled to Porous Glass. Biochem. Biophys. Acta, 185, 464 (1969).
- (50) WEIBEL, M.K., BRIGHT, H.J., The Glucose Oxidase Mechanism. Interpretation of the pH Dependence. J. Biol. Chem. 246, 2734 (1971).
- (51) SWOBODA, B.E.P., The Mechanism of Binding of Flavine-Adenine Dinucleotide to the Apoenzyme of Glucose Oxidase and Evidence for the Involvement of Multiple Bonds. Biochem. Biophys. Acta, 175, 380 (1969).
- (52) KEILIN, D., HARTREE, E.F., Properties of Glucose Oxidase (Notatin). Biochem. J. 42, 221 (1948).
- (53) GIBSON, Q.H., SWOBODA, B.E.P., MASSEY, V., Kinetics and Mechanism of Action of Glucose Oxidase. J. Biol. Chem. 239 (11), 3927 (1964).
- (54) ROUGHTON, F.J.W., A Method of Allowing for the Influence of Diffusion in Manometric Measurements of Certain Rapid Biochemical Reactions. J. Biol. Chem. 141, 129 (1941).
- (55) GIBSON, Q.H., In Methods in Enzymology. KOLOWICK, and KAPLAN, (eds.) Vol. 16. p. 187. (1969).
-

-
- (56) WEIBEL, M.K., BRIGHT, H.J., Glucose Oxidase Mechanism
J. Biol. Chem. 246, 2734 (1971).
- (57) TOTH, G.M., Oxidation-Reduction Potential in Animal
Cell Cultures. In Advances in Biochemical Engin-
eering. Springer Verlag, Berlin (In Press).
- (58) BEINERT, H., Flavin Coenzymes. In the Enzymes.
BOYER, P.D., LARDY, H., and MYRBÄCK, K. (eds.).
2nd Edition. p. 339. Academic Press, New York (1960).
- (59) GOLD, V., BETHELL, D., In Advances in Physical
Organic Chemistry, Vol. 12., Academic Press,
London, New York, San Francisco (Harcourt Brace
Jovanovich, Publ.) 1976.
- (60) AINSWORTH, G.C., SUSSMAN, A.S., The Fungi. Vol. 1,
p. 254. Academic Press, New York-London (1965).
- (61) BOUTROUX, L. Sur un Fermentation nouvelle du Glucose.
Compte. Rend. 91, 236 (1880).
- (62) MOLLIARD, M. Sur une nouvelle fermentation acide
produite par le Sterigmatocystis nigre. Comp.
Rend. 174, 881 (1922).
- (63) BERNHAUER, K., French Patent 707,614 (1931).
- (64) SCHREYER, R., Vergleichende Untersuchungen über
die Bildung von Gluconsäure durch Schimmelpilze.
Biochem. Zeit., 240, 295 (1931).
- (65) BERNHAUER, K., SCHULHOF, L., Production of Gluconic
Acid, U.S. Patent 1,849,053, (March 15, 1932).
- (66) MAY, O.A., HERRICK, H.T., WELLS, P.A., Gluconic Acid
Production by Submerged Mold Growths under Increased
Air Pressure. Ind. Eng. Chem. 26, 575 (1934).
-

-
- (67) WELLS, P.A., MOYER, A.J., STUBBS, J.J., HERRICK, H.T. MAY, O.E., Ind. Eng. Chem. 29, 653 (1937).
- (68) LOCKWOOD, L.B., TABENKIN, B., WARD, G.E., The Production of Gluconic Acid and 2-Ketogluconic Acid from Glucose by Species of Pseudomonas and Phytomonas. J. Bact., 42, 51 (1941).
- (69) PRESCOTT, S.C., DUNN, C.G., Industrial Microbiology, McGraw-Hill Book Company, Inc., New York. 3rd Edition (1959).
- (70) ALSBERG, C.L., The Formation of D-gluconic Acid by Bacterium sevastanoi, Smith. J. Biol. Chem., 9, 1 (1911).
- (71) PERVOZVANSKI, V.V., IVASHKEVICH, M.A., Fermentation of Gluconic Acids in Bacterium putidum L. et N., Microbiologia 8 (3-4), 339 (1939).
- (72) HUMPHREY, A.E., REILLY, P.J., Kinetic Studies of Gluconic Acid Fermentations. Biotechnol. and Bioeng. 7, 229 (1965).
- (73) KOGA, S., BURG, C.R., HUMPHREY, A.E., Computer Simulation of Fermentation Systems. Appl. Microbiol. 15, 683 (1967).
- (74) NYIRI, L.K., JEFFERIS, R.P., TOTH, G.M., LEAR, J.L., Analysis and Identification of Status of Fermentation Processes by Computers. 75th AIChE National Meeting, Detroit, Michigan (1973).
- (75) RAI, V.R., CONSTANTINIDES, A., Mathematical Modeling and Optimization of the Gluconic Acid Fermentation. AIChE Symposium Series 69 (13), 114, (1974).
- (76) NYIRI, L.K., TOTH, G.M., Hysteresis in Dynamic Enzyme Model. Biotechnol. Bioeng. 13, 697 (1971).
-

-
- (77) TSAO, G.T., KEMPE, L.L., J. Biochem. Microbiol. Techn. Eng. 2, 129 (1960).
- (78) ISBELL, H.S., Process for the Preparation of Crystalline Gluconic Acid. U.S. Patent 1,985,255 (Dec. 25, 1934).
- (79) GELDER, D.W., Gluconic Acid Monohydrate. U.S. Patent 2,916,515 (Dec. 8, 1959).
- (80) WHITE, A., HANDLER, P., SMITH, E.L., Principles of Biochemistry. Fifth Edition. McGraw-Hill Co., New York (1973).
- (81) KUPPERMAN, H.S., Human Endocrinology. F.A. Davis Co., Vol. 3, p. 832 (1963).
- (82) AREHART-TREICHEL, J., Brain Peptides and Psychopharmacology. Science News 110, 202 (1976).
- (83) KUTSKY, R.J., Handbook of Vitamins and Hormones. Van Nostrand, New York (1973).
- (84) KARLSON, P., Introduction to Modern Biochemistry. 2nd Edition. Academic Press, New York (1965).
- (85) TASHJIAN, A.H., Animal Cell Cultures as a Source of Hormones. Biotechnol. Bioeng. 11, 109 (1969).
- (86) KRUSE, P.F., Jr., PATTERSON, M.K., Jr., Tissue Culture. Methods and Applications. Academic Press, New York (1973).
- (87) ALBRITTON, E.C., Standard Values in Blood. p. 120. Saunders, Philadelphia, Pa. (1952).
- (88) NYIRI, L.K., Role of CO₂ in Microbial Processes. in Advances in Biochemical Engineering. Springer Verlag, Berlin (In Press).
-

-
- (89) AUGENSTEIN, D.C., SINSKEY, A.J., WANG, D.I.C., Effect of Shear on the Death of two Strains of Mammalian Tissue Cells. *Biotechnol. Bioeng.* 13, 409 (1971).
- (90) TELLING, R.C., RADLETT, P.J., Large-Scale Cultivation of Mammalian Cells. In: *Advances in Applied Microbiology* 13, 91 (1970).
- (91) KILBURN, D.G., WEBB, F.C., The Cultivation of Animal Cells at Controlled Dissolved Oxygen Partial Pressure. *Biotechnol. Bioeng.* 10, 801 (1968).
- (92) FOGH, J., HOLMGREN, N.B., LUDOVICI, P.P., *In Vitro* 7, 26 (1971).
- (93) STOKER, M. O'Neil, G.P., BERRYMAN, S., WAXAMAN, V., *Intl. J. Canc.* 3, 683 (1968).
- (94) ELSWORTH, R., Multi-layer Perfusion Tissue Culture, *Process Biochem.* p. 21 (March, 1970).
- (95) KNAZEK, R.A., GULLINO, P.M., DEDRICK, R.L., Cell Culture on Artificial Capillaries: An Approach to Tissue Growth *in vitro*. *Science* 178, 64 (1972).
- (96) JOHNSON, D.E., WOODLAND, L.R., KENSLER, C.J., HIMMELFARB, P., Spin Filter Culture Device. U.S. Patent, 3,647,632 (March 7, 1972).
- (97) NYIRI, L.K., Design Considerations for Animal Cell Cultures as Sources of Enzymes. in *Enzyme Engineering*. PYE, E.K. and WINGARD, L.B., Jr. (eds.), Vol. 2, p. 31. Plenum Press, New York (1973).
- (98) LYNN, J.D., ACTON, R.T., Design of a Large-Scale Mammalian Cell Suspension Culture Facility. *Biotechnol. Bioeng.* 17, 659 (1975).
-

-
- (99) VanHEMERT, P., KILBURN, D.G., VanWEZEL, A.L., Homogenous Cultivation of Animal Cells for the Production of Virus and Virus Products. *Biotechnol. Bioeng.* 11, 875 (1963).
- (100) THAYER, P.S., Spin Filter Device for Suspension Cultures. In: *Tissue Culture. Method and Application.* KRUSE, P.F. and PATTERSON, M.K. (eds.) Academic Press, New York (1973).
- (101) BRADVAROVA, I., ATSEV, S., VASILENKO, S., Method of Three-dimensional Cell Cultivation. *Voprosy Virusologii* 1, 100 (1968).
- (102) WILKINS, J.R., HATTEN, M.B., SALMIRS, S., Effect of Gravity on the Colonial Morphology of Staphylococci in Soft Agar. *Appl. Microbiol.* 18, 680 (1969).
- (103) TAYLOR, G.R., Survey on Cell Biology Experiments in Reduced Gravity. Colloquium on Bioprocessing in Space, LBJ Space Center, Houston, Texas (March, 1976).
- (104) DREW, S., Personal Communication during the Bioprocessing in Space Colloquium. Houston, TX (1976).
- (105) JOHNSON, I.S., BODER, G.B., Metabolites from Animal and Plant Cell Culture. In: *Advances in Applied Microbiology.* PERLMAN, D. (ed.), vol. 15. p. 219. Academic Press, New York (1972).
- (106) YASUMURA, Y., TASHJIAN, A.H., SATO, G.H., Establishment of Four Functional Clonal Strains of Animal Cells in Culture. *Science* 154, 1186 (1966).
- (107) HAFFEN, K., CEDARD, L., *C.R. Acad. Sci.* 264, 1923 (1967).
-

-
- (108) WENIGER, J.P., EHRHARDT, J.D., FRITIG, B., C.R. Acad. Sci. 264, 1069 (1967).
- (109) TONG, W., Axenic Mammalian Cell Reaction (Tritsch, G.L. (ed.). p. 261. Dekker, New York (1969).
- (110) BANKROFT, F.C. and TASHJIAN, A.H., In Vitro 6, 180 (1970).
- (111) KOWAL, J., Recent Prog. Hormone Res. 26, 623 (1970).
- (112) PAVLOVIC-HOURNAC, M., RAPPAPORT, L., NUNEZ, J., Exptl. Cell Res. 68, 332 (1971).
- (113) BODER, G.B., ROOT, M.A., CHANCE, R.E., JOHNSON, I.S., Proc. Soc. Exptl. Biol. Med. 131, 507 (1969).
- (114) PATTILLO, R.A., GEY, G.O., The Establishment of A Cell Line of Human Hormone-Synthesizing Trophoblastic Cells in vitro. Cancer. Res. 28, 1231 (1968).
- (115) GAUTVIK, K.M., TASHJIAN, A.H., In: Tissue Culture. Methods and Applications. KRUSE, P.F. and PATTERSON, M.K. (eds.) Academic Press, New York (1973).
- (116) DANNIES, P.S., TASHJIAN, A.H., Jr., Growth Hormone and Prolactin from Rat Pituitary Tumor Cells. In: Tissue Culture. Methods and Applications. KRUSE, P.F. and PATTERSON, M.K. (eds.). Academic Press, New York, p. 561 (1973).
- (117) LEVINE, L., VanVUNAKIS, H., In: Methods in Enzymology (HIRS, C.H.W. ed.). Vol. 11, p. 928. Academic Press, New York (1967).
- (118) TASHJIAN, A.H., BANCROFT, F.C., LEVINE, L., Production of Both Prolactin and Growth Hormone by Clonal Strains of Rat Pituitary Tumor Cells. J. Cell. Biol. 47, 61 (1970).
-

-
- (119) TASHJIAN, A.H., HINKLE, P.M., DANNIES, P.S., Proc. 4th Intern. Congr. Endocrinol. Excerpta Medica. Amsterdam (1973).
- (120) HORNG, C.B., McLIMANS, W., Primary Suspension Culture of Calf Anterior Pituitary Cells on a Microcarrier Surface. Biotechnol. Bioeng. 17, 713 (1975).
- (121) PATTILLO, R.A., Human Chorionic Gonadotropin. In: Tissue Culture. Methods and Applications. KRUSE, P.F., Jr., and PATTERSON, M.K. (eds.). Academic Press, New York, p. 575 (1973).
- (122) UNGAR, G., DESIDERIO, D.M., PARR, W., Isolation, Identification and Synthesis of a Specific-behaviour-inducing Brain peptide. Nature 238, 198 (1972).
- (123) ANONYM, ICI to Scale Up Single Cell Protein Process. C&EN, p. 25 (Oct. 11, 1976).
- (124) United States Tariff Commission. Synthetic Organic Chemicals. United States Production and Sales (1971, 1974). U.S. Government Printing Office, Washington (1973, 1976).
- (125) Evaluation of Protein Quality. Publication 1100. NAS-NRC Publication, Washington, D.C. (1963).
- (126) The Pharmacopeia of the United States of America, Eighteenth Revision, 4630 Montgomery Avenue, Bethesda, Md., September 1, 1970.
- (127) LI, C.H., DIXON, J.S., Human Growth Hormone, XXXII. The Primary Structure of the Hormone: Revision. ArCh. Biochem. Biophys. 146, 233 (1971).
- (128) FRIEDEN, E., LIPNER, H., Biochemical Endocrinology of the Vertebrates. Prentice Hall, Inc., Englewood Cliffs, N.J. (1971).
-

-
- (129) WILLIAMS, R.H., Endocrinology. W.B. Sanders Co., Philadelphia & London (1963).
- (130) ARTHUR D. LITTLE, INC.: Feasibility Study for the Manufacture of Zero Gravity Pharmaceuticals, Immunobiological, and Viral Agents. NASA-CR-120424, Aug. 29, 1974.
- (131) RUSSEL, T.W.F., DUNN, I.J., BLANCH, H.W., The Tubular Loop Batch Fermentor: Basic Concepts. Biotechnol. and Bioeng. 16, 1261 (1974).
- (132) ZIEGLER, H., DUNN, I.J., BOURNE, J.R., RUSSEL, T.W.F., Tubular Loop Fermentor Characteristics. Proc. of 5th Intl. Fermentation Symposium (DELLWEG, H. (ed.)). 4.10. p. (1976).
- (133) NASA, Announcement of Opportunity, A.O. No. OA-76-02 (February 6, 1976).
- (134) NASA, Announcement of Opportunity for Space Shuttle Orbital Flight Test Program. A.O. No. OPPJ-76-1 (Sept. 1976).
- (135) NASA, Announcement of Opportunity for First Space-lab Mission. AO-CSS-1-76.
-