

CONTROL OF PROPULSION SYSTEMS FOR SUPERSONIC CRUISE AIRCRAFT

Kirby W. Hiller and Daniel I. Drain
NASA Lewis Research Center

SUMMARY

The unique propulsion control requirements of supersonic aircraft are presented. Integration of inlet, engine, and airframe controls is discussed. The application of recent control theory developments to propulsion control design is described. Control component designs for achieving reliable, responsive propulsion control are also discussed.

INTRODUCTION

Propulsion controls are vital to the successful functioning of supersonic aircraft. As an example of what a propulsion control is supposed to do, consider the YF-12 aircraft shown in figure 1. The YF-12 employs mixed-compression inlets and afterburning turbojet engines. When the aircraft is cruising under design conditions, the control's job is to operate the mixed-compression inlet so that it produces high pressure recovery. The engine must be operated under conditions of high efficiency while avoiding limits such as rotor overspeed and turbine overtemperature. The control must ensure stable operation so that an atmospheric disturbance does not cause the inlet to unstart. Unstart is the phenomenon where the shock pops out in front of the inlet and the pressure recovery drops. The control also has to accommodate off-design operations like takeoff, climb, descent, and landing. The control must balance high efficiency against stability. For example, this kind of inlet achieves its highest pressure recovery when it is just on the verge of unstart. Controls developments now underway may make it possible to ease the harshness of this compromise. Thus, to a degree, we will be able to improve efficiency without losing stability.

As further background, consider the elements that make up an engine speed control (fig. 2). A commanded speed is fed to a computer. There it is compared against the sensed speed. The speed error is determined by the computer and used to drive an actuator - in this case, the fuel valve. The change in fuel flow to the engine changes engine speed so as to reduce the speed error. This is called a control loop; its components, the computer, the actuator, and the sensor, appear in every control system. Other control developments now in progress are improving the type of hard-

ware that will be used in these components. The simpler notation in the lower part of figure 2 can be used to represent the control. The hollow arrow implies that several signals can be transmitted both ways. The "control" box can represent several control loops like the one above it. Even a simple nonafterburning subsonic engine can employ as many as three control loops.

INLET AND ENGINE CONTROL REQUIREMENTS

Having established this background the subject at hand, supersonic propulsion control, can now be discussed. An inlet that might be used in a supersonic aircraft is shown in figure 3. It is an axisymmetric, mixed-compression inlet with a translating centerbody. The inlet variables that a control would manipulate are called out in the figure. Two main inlet control variables are translation of the centerbody and opening of the bypass doors. Translating the centerbody controls the strength of the normal shock. Opening the bypass doors controls the position of the normal shock to a location just aft of the throat. For takeoff and acceleration, auxiliary flow doors might also be used to increase inlet-supplied airflow (ref. 1).

One type of advanced engine that might be used in a supersonic aircraft is shown in figure 4. It is the Pratt & Whitney variable stream control engine (refs. 2 and 3). The temperature and velocity of the two streams are controlled independently. The engine variables that a control would manipulate are variable geometry in the fan and in the core compressor, two independently controlled fuel flows for the main combustor and two for the duct combustor. Control of the exhaust nozzle would entail actuation of four items: ejector doors (for bringing in auxiliary airflow), the duct nozzle, the primary nozzle, and a thrust-reversing clamshell. The free-floating divergent flaps would not be controlled. This adds up to 10 independently controlled variables for the engine and three for the inlet. Other inlet and engine designs could involve more variables; additional variables could include turbine-outlet guide vanes, tip clearance controls, and additional auxiliary air intakes for the inlet.

The features of this supersonic propulsion system that present unique control requirements are as follows: First, it is obvious that the number of manipulated variables will be large. Also, the mixed-compression inlet has the inherent danger of unstart. Economics would motivate us to operate the inlet with the shock well forward, near the verge of unstart. Coupling this inlet to an augmented bypass engine could permit an airflow transient to propagate forward through the unchoked fan, resulting in an inlet unstart (refs. 4 and 5). Yet in a commercial aircraft a violent inlet unstart would be very objectionable. Also the controls must operate in a high-temperature environment. Taken together, these features imply the need for some important advances in propulsion controls.

CONTROL INTEGRATION

The most important propulsion control advancement occurring today is the use of digital control computers. Computers allow us to exercise more complex control laws and thus to more closely integrate the inlet, engine, and airframe controls. Control integration is illustrated by figures 5 and 6. Figure 5 represents the separate controls for the inlet (three control loops) and the engine (10 control loops). Most supersonic propulsion controls transmit some coordination signals between the inlet and engine controls, as illustrated by the lower arrow in figure 6. Usually, these signals are simple overrides.

Some research programs have carried integration past the point of simple overrides. Figure 7 shows a mixed-compression inlet/turbojet engine combination that was investigated at the Lewis Research Center. The inlet and engine were operated under computer control (refs. 6 and 7). We found that if the bypass doors were open, spilling a lot of air, we could increase engine airflow by uptrimming engine speed. This forced the bypass doors to close, eliminating bypass drag and improving cruise efficiency. Now we had two ways to control shock position and so could do it more effectively. In addition, the problem of inlet-engine matching was simplified. Normally, matching is done by building the inlet to close tolerances and then trimming the engine's airflow on a calibration stand. This automatic engine trimming feature has been incorporated in the controls for the B-1 aircraft.

Figure 8 shows another inlet/engine combination investigated at the Lewis Research Center, a turbofan and a mixed-compression inlet. This model was operated under digital computer control (ref. 5). It was the first time a turbofan and mixed-compression inlet had been operated together. We found that inlet operation is more sensitive to engine operation with this kind of an engine. An afterburner lightoff can feed forward through the unchoked fan to unstart the inlet (refs. 4 and 5). However, the afterburner never lights off without action initiated by the engine control. Thus, a simple anticipator, resetting normal shock position to a more aft location, could permit safe afterburner lightoff. This inlet/engine combination did not present insurmountable interaction problems. In steady operation, the afterburner did not excite inlet instabilities. However, we did have to reset inlet operation to anticipate afterburner transients.

A further step in integration studies was the Integrated Propulsion Control System (IPCS) program (ref. 8). This was a joint Air Force-NASA program involving the F-111 aircraft (fig. 9). One of the inlet/engine systems of an F-111 aircraft was operated under electronic digital control. Some of the important aspects of the program are as follows: Inlet distortion was sensed on line by five electronic pressure transducers. This distortion was converted to a distortion index and used to control the

opening of the seventh-stage compressor bleeds. Opening the bleeds reduced the pressure ratio of the front stages, increasing their distortion tolerance but reducing overall engine efficiency. Using the distortion index to operate the bleeds delayed their opening point to a higher Mach number. If both inlet/engine systems had been under digital control, the cruise range at Mach 2.2 would have been increased by 16 percent (ref. 9). A number of new control modes were incorporated into the F-111's electronic control. Two gave results of distinct importance. By sensing compressor discharge Mach number, tighter control of the surge margin was obtained during acceleration. With the tighter schedule, engine acceleration time was shortened. On the average, acceleration time was reduced by 26 percent. Also by including fan pressure ratio sensing and using more complex logic to control fuel flows to the afterburner fuel manifolds, the military to maximum afterburning transient time could be shortened. The transient time was reduced by 40 percent on the average.

ADVANCED CONTROL THEORY APPLICATION

In its ultimate version, integration of propulsion controls will assume a form where a separate inlet and engine control are no longer identifiable. This integration will be facilitated by the application of advanced control theory. The application of this theory to an engine alone will take the form illustrated in figure 10. Through a matrix of gains, every input will affect every output to a greater or lesser degree, depending on each element of the matrix. The resulting control is termed a "modern" control to distinguish it from conventional control designs that would be termed "classical" controls.

Modern control theory was developed to handle the problems of systems with dozens of inputs and outputs, such as process controls. It has the following advantages: It is a computer-aided design process. It results in controls that are optimal. A mathematically described performance index establishes the optimized control gains. It is especially suited to the design of multiloop controls. And, its use eliminates loop interactions, where closing one loop destabilizes another.

One of the most thoroughly developed modern control techniques is called Linear Quadratic Regulator Theory, or LQR (ref. 10). The term is derived from the facts that the plant is assumed to be linear and that the performance index uses weighting factors which give rise to matrix equations involving quadratic forms. An LQR-designed control for the F100 engine is being developed under a joint Air Force/NASA contract. The design is to be evaluated at the Lewis Research Center on an F100 engine in an altitude tank (fig. 11). The engine will be operated under digital control from a computer located in the simulation facility. At the moment, we are controlling a real-time simulation of the F100 engine from the same digital control computer in

preparation for the experimental program (ref. 11).

This program is the first experimental application of LQR theory to a propulsion system. Its objective is to see if LQR can be adapted to the nonlinear control requirements of an F100 engine. To accommodate the nonlinear effects, LQR designs for selected operating points within the flight envelope are stored in the engine controller. The control gains are blended between adjacent operating points to obtain continuous nonlinear control.

Of course, the modern control design technique is not limited to just one control at a time. As shown in figure 12, it can include the inlet, engine, and airframe controls in one formulation. As the control encompasses more of the whole system, its advantages increase. If the F100 program is successful, it may be expanded to flight demonstrations of airframe/inlet/engine controls.

CONTROL COMPONENTS

Unique to electronic control is the reliability problem with electronic hardware. Electronic sensors and actuators are remarkably less reliable than older components like a bellows pushing on a lever. Electrical transmission of signals is prone to electromagnetic interference, and electrical connectors can become unreliable in humid or salty environments. Electronic controls have the ability to process multiple signals, permitting use of more complex sensors. Also the digital computer needs sensors and actuators that communicate with digital signals or with something like frequency or pulse width, where counting or timing can be used. These characteristics of electronic control will give rise to new control sensors and actuators that are more suitable for use with electronic propulsion control. They will be reliable, may provide more complex input signals, and will communicate digitally. We at Lewis and others are working on these digital-compatible components (ref. 12).

The reliability problem of the engine-mounted electronic control is illustrated in figure 13. Mounting the computer, sensors, and actuators on the engine subjects them to high temperatures and vibration levels. For the supersonic aircraft the engine compartment temperatures will be higher and cooling fuel will be hotter. One solution is presented in figure 14. Here two steps are taken to improve reliability: the computer is off-engine mounted, and the sensors and actuators employ fiber-optic signal transmission, wherein signals are transmitted by light via bundles of optical fibers. Optical signal transmission has been found to be immune to the problems of electrical interference that plague electrical communications. The design of a fiber-optic-connected sensor is illustrated in figure 15. In the digital computer package would be a light source and lens system to illuminate the optical fiber ends. Only rugged, passive components would be mounted on the engine. The mask, whose translation is the

variable being measured, would interrupt the light beams like an encoder mask. The receiver fibers would then be illuminated, depending on the mask position. The output from the detectors would be a parallel digital word that could be used directly by the digital computer.

Although the thrust today is in the direction of greater controls sophistication, an inescapable limitation is the speed of response of the control actuator. The bypass doors shown in figure 16 would not be able to compensate for disturbances having frequencies higher than 1 or 2 hertz even though a supersonic inlet can respond to disturbances having frequencies of 30 hertz. The stability of a supersonic inlet can be improved by using self-acting valves ahead of the throat that open in response to the pressure rise across the shock. These valves can then bleed air out of the inlet in tandem with the bypass doors in order to draw the shock back to a stable location. This design is shown in greater detail in figure 17. Here, the static pressure behind the shock is higher. This higher pressure bleeds into the chamber under the valve and forces the valve piston open. Air then bleeds out of the inlet, stabilizing the position of the normal shock. A system like this was tested on a YF-12 inlet in a Lewis supersonic wind tunnel (refs. 13 to 16). It extended the frequency range of disturbances the inlet could tolerate by a factor of more than 10. This is an example of a technique that would permit operating at higher efficiency without sacrificing stability.

CONCLUSIONS

In conclusion, it has been shown that the control needs of supersonic aircraft are significantly more stringent than those of subsonic aircraft. Controlling the many variables involved will require a combination of sophisticated digital control computers, advanced-design control laws, possible use of novel inlet bleed valves, and reliable digital-compatible sensors and actuators. Military and civil programs will be advancing the state of the art in these areas. But these programs should be watched closely and special attention given to the specific needs of the commercial supersonic aircraft. These needs are likely to be in the areas of mixed-compression-inlet stability, controls for variable-cycle engines, multivariable control for an interacting inlet/engine/airframe system, and high-temperature control components.

REFERENCES

1. Sorensen, Norman E.; Latham, Eldon A.; and Smeltzer, Donald B.: Variable Geometry for Supersonic Mixed-Compression Inlets. *J. Aircr.*, vol. 13, no. 4, Apr. 1976, pp. 309-312.
2. Weber, Richard J.: NASA Propulsion Research for Supersonic Cruise Aircraft. *Astronaut. Aeronaut.*, vol. 14, no. 5, May 1976, pp. 38-45.
3. Willis, Edward: Variable-Cycle Engines for Supersonic Cruise Aircraft. NASA TM X-73463, 1976.
4. Baumbick, Robert J.; Batterton, Peter G.; and Daniele, Carl J.: Effect of Afterburner Lights and Inlet Unstarts on a Mixed-Compression-Inlet Turbofan Engine Operating at Mach 2.5. NASA TM X-3223, 1975.
5. Batterton, Peter G.; Arpasi, Dale J.; and Baumbick, Robert J.: Digital Integrated Control of a Mach 2.5 Mixed-Compression Supersonic Inlet and an Augmented Mixed-Flow Turbofan Engine. NASA TM X-3075, 1974.
6. Cole, Gary L.; Neiner, George H.; and Wallhagen, Robert E.: Coupled Supersonic Inlet-Engine Control Using Overboard Bypass Doors and Engine Speed to Control Normal Shock Position. NASA TN D-6019, 1970.
7. Paulovich, Francis J.; Neiner, George H.; and Hagedorn, Ralph E.: A Supersonic Inlet-Engine Control Using Engine Speed as a Primary Variable for Controlling Normal Shock Position. NASA TN D-6021, 1971.
8. Bentz, Charles E.; and Zeller, John R.: Integrated Propulsion Control System Program. SAE Paper 730359, Apr. 1973.
9. Burcham, F. W., Jr.; and Batterton, P. G.: Flight Experience with a Digital Integrated Propulsion Control System on an F-111E Airplane. AIAA Paper 76-653, July 1976.
10. Special Issue on the Linear-Quadratic-Gaussian Estimation and Control Problem. *IEEE Trans. Autom. Control*, vol. AC-16, no. 6, Dec. 1971, pp. 527-869.
11. Seldner, Kurt: Simulation of a Turbofan Engine for Evaluation of Multivariable Optimal Control Concepts. NASA TM X-71912, 1976.
12. Kast, Howard: Fail-Fixed Servovalve. AFAPL-TR-76-24, General Electric Co., 1976.
13. Blausey, G. E.; Coleman, D. M.; and Harp, D. S.: Feasibility Study of Inlet Shock Stability System of YF-12. (SP-1964, Lockheed Aircraft Corp.) NASA CR-134594, 1972.

14. Cole, Gary L.; Dustin, Miles O.; and Neiner, George H.: A Throat-Bypass Stability System for a YF-12 Aircraft Research Inlet Using Self-Acting Mechanical Valves. NASA TM X-71779, 1975 (Also available as AIAA Paper 75-1181).
15. Dustin, Miles O.; and Neiner, George H.: Evaluation by Step Response Tests of Prototype Relief Valves Designed for YF-12 Inlet Stability Bleed System. NASA TM X-3262, 1975.
16. Webb, John A., Jr.; and Dustin, Miles O.: Analysis of a Stability Valve System for Extending the Dynamic Range of a Supersonic Inlet. NASA TM X-3219, 1975.

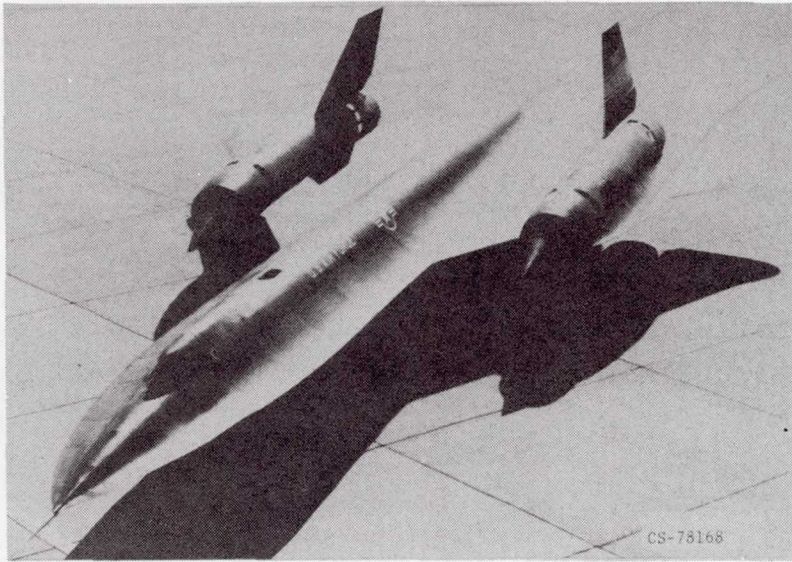

Figure 1.- YF-12 aircraft.

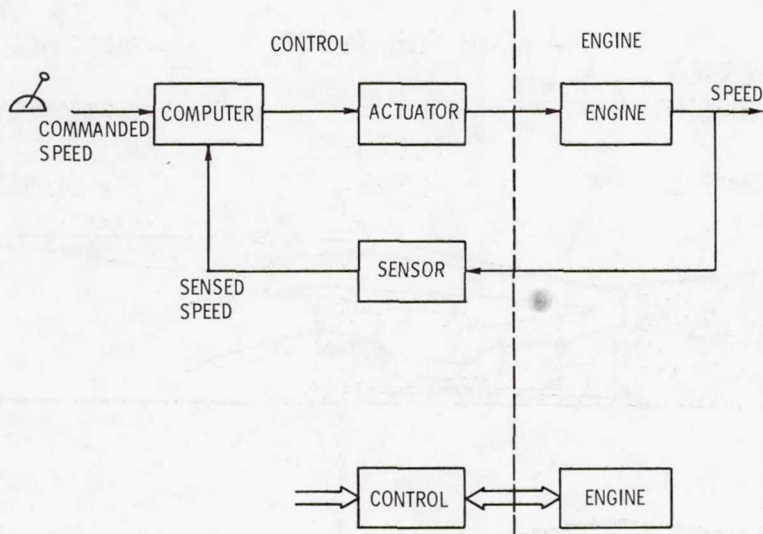

Figure 2.- Elements of an engine speed control system.

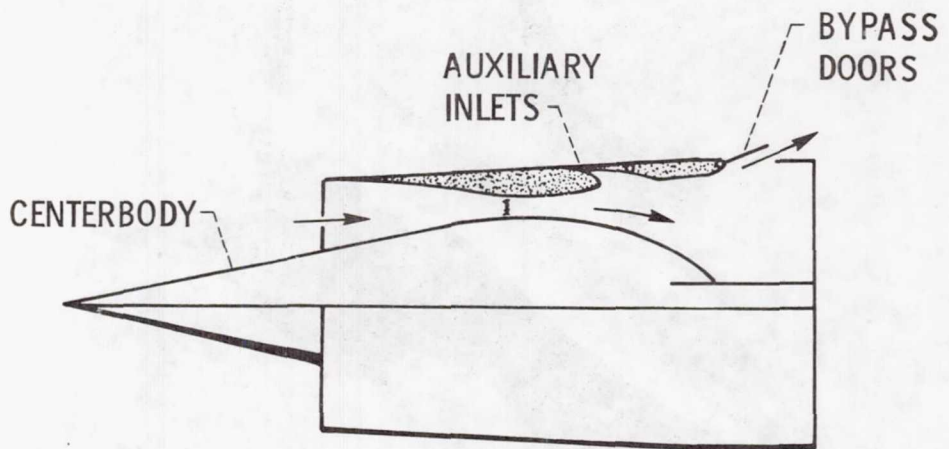

Figure 3.- Supersonic, mixed-compression inlet, showing control variables.

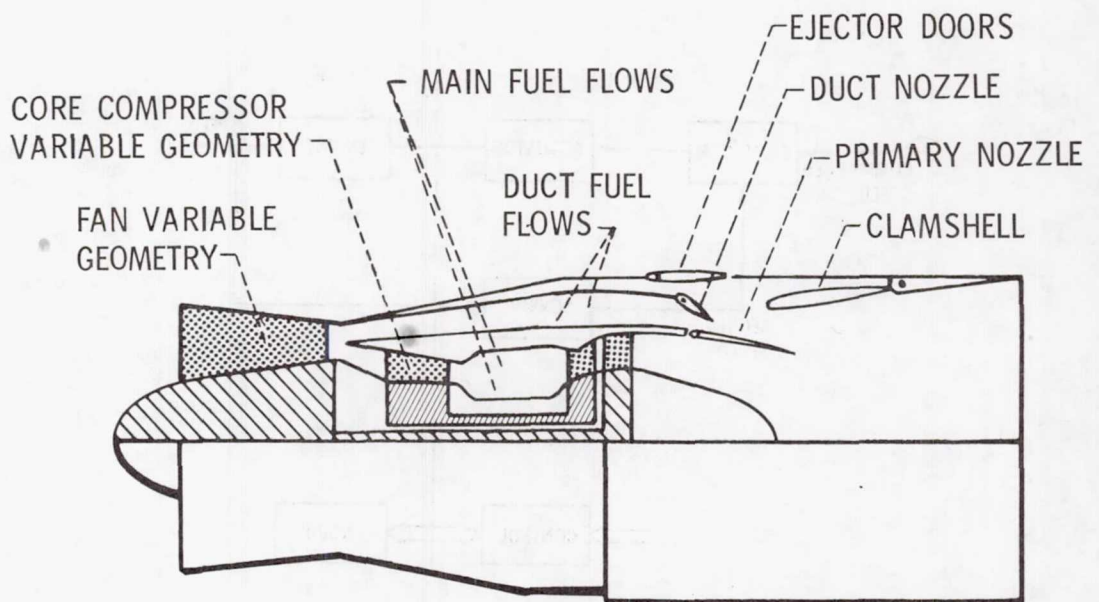

Figure 4.- Supersonic engine, showing control variables.

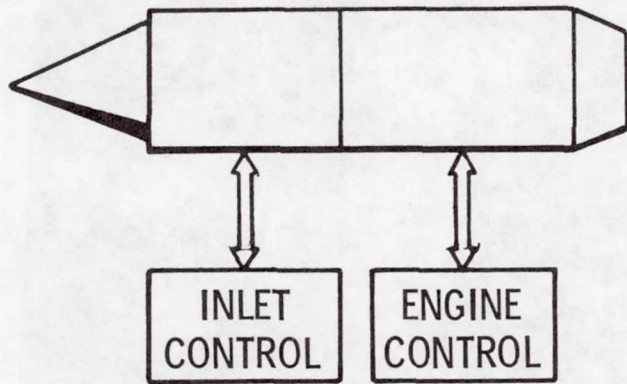

Figure 5.- Separate inlet and engine controls.

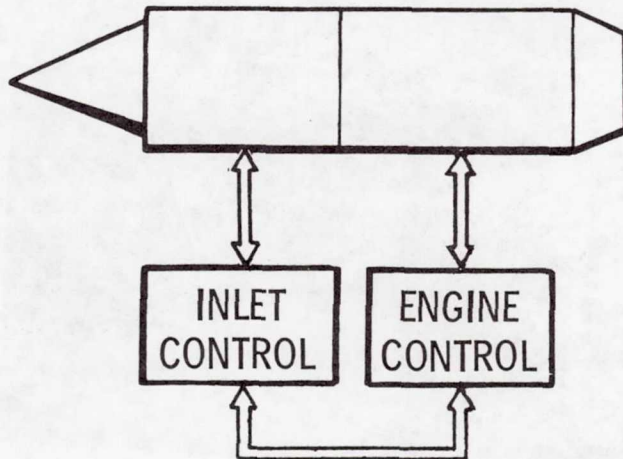

Figure 6.- Integrated propulsion control.

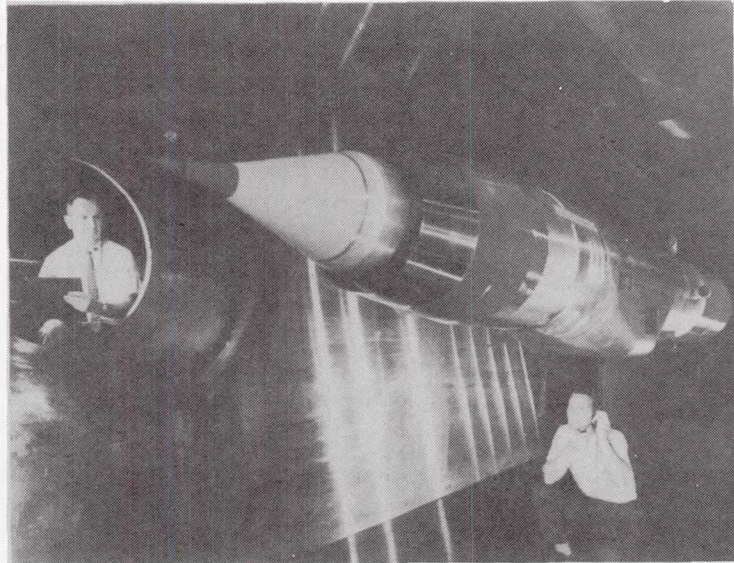

Figure 7.- Mixed-compression inlet and J85 turbojet engine in 10- by 10-foot supersonic wind tunnel.

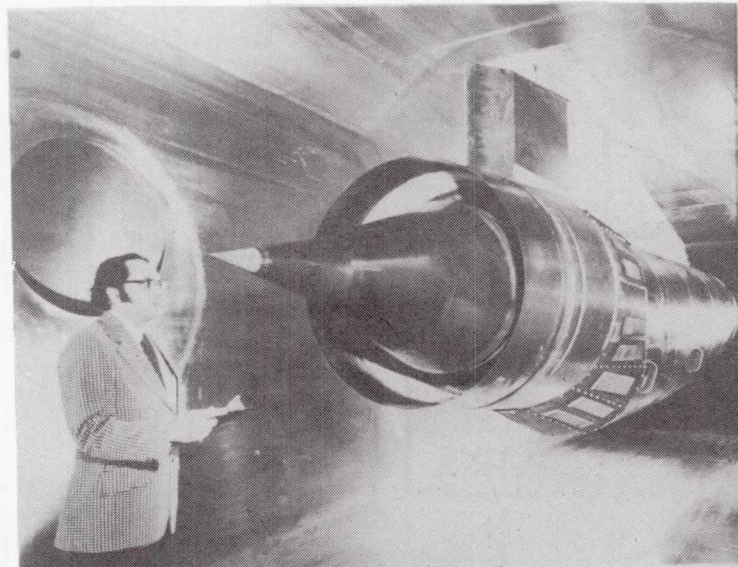

Figure 8.- Mixed compression inlet and TF-30 turbofan engine in 10- by 10-foot supersonic wind tunnel.

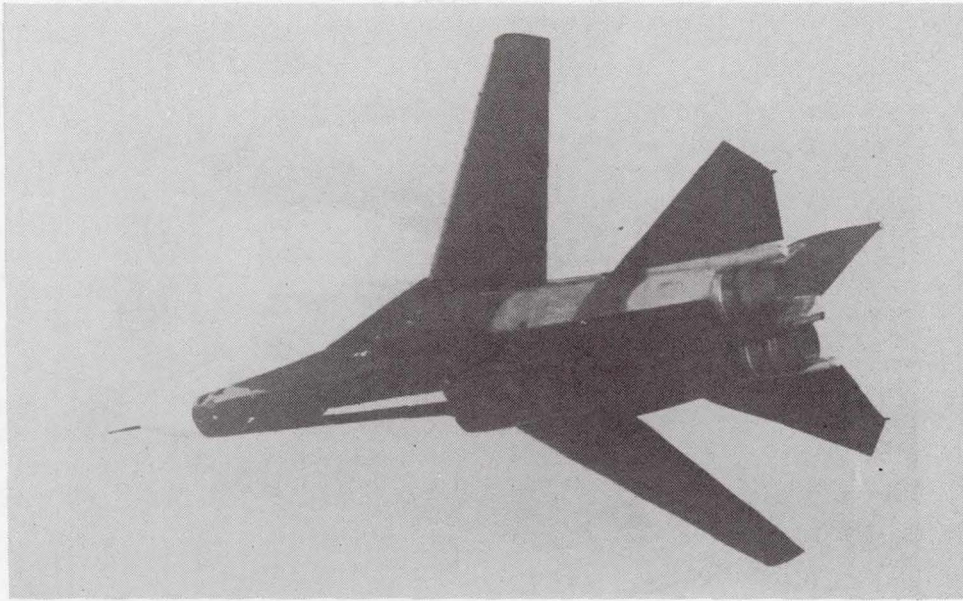

Figure 9.- F-111 aircraft.

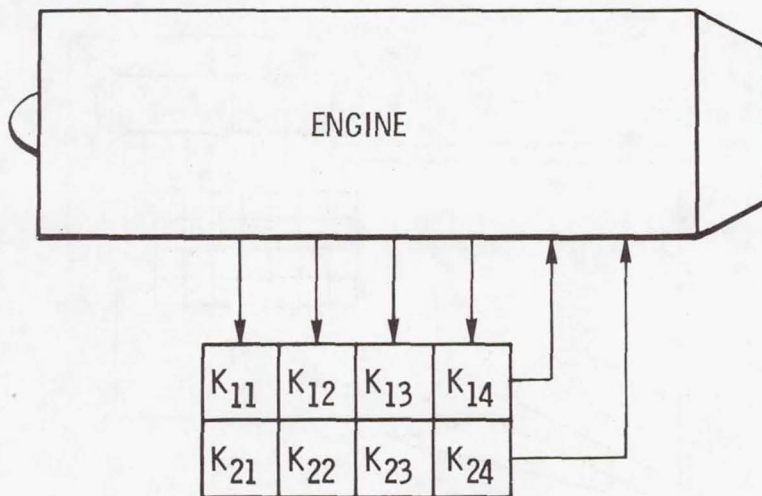

Figure 10.- Modern control theory applied to an engine.

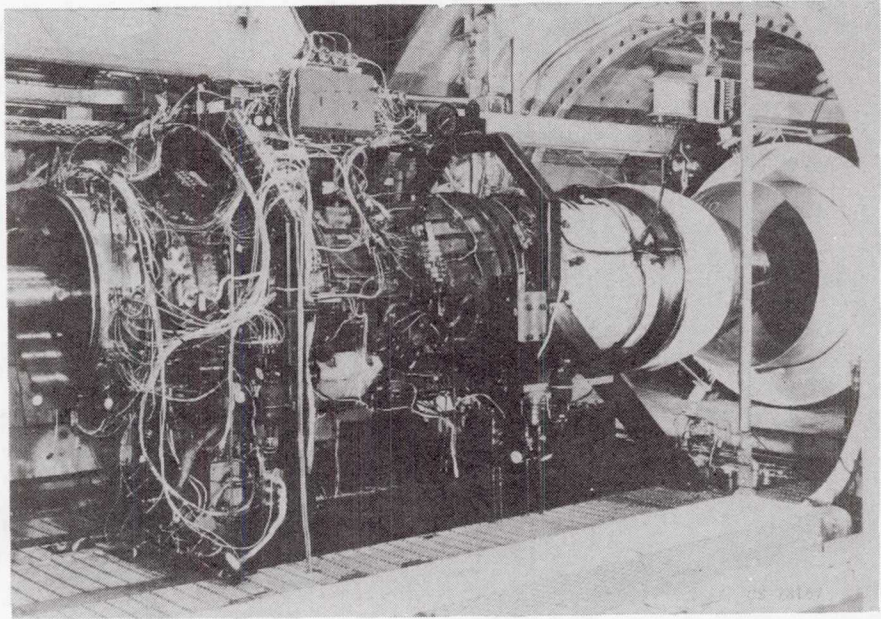

Figure 11.- F100 engine in altitude tank.

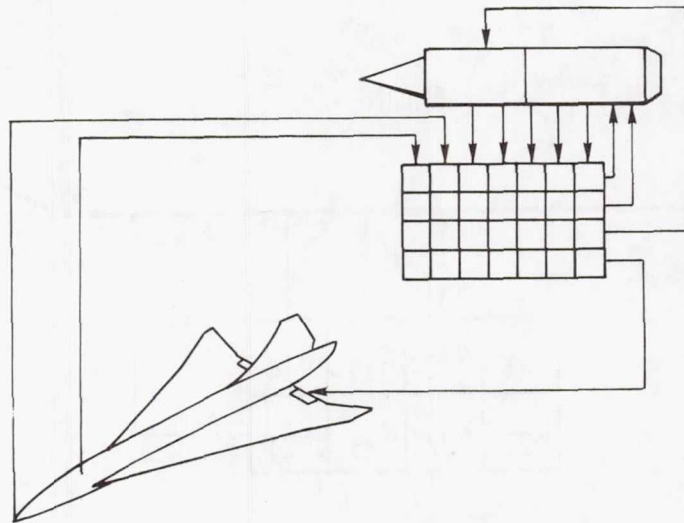

Figure 12.- Modern control of overall system.

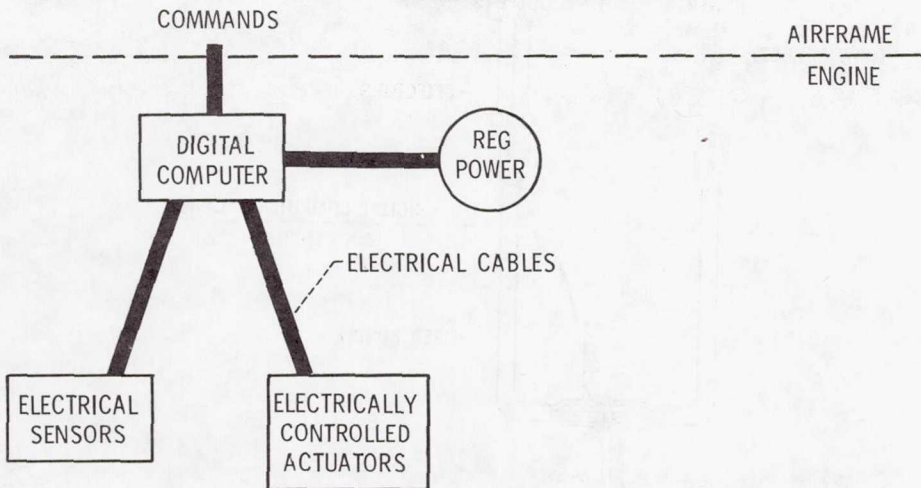

Figure 13.- Digital electronic engine control where computer is mounted on engine and cables are used for signal transmission.

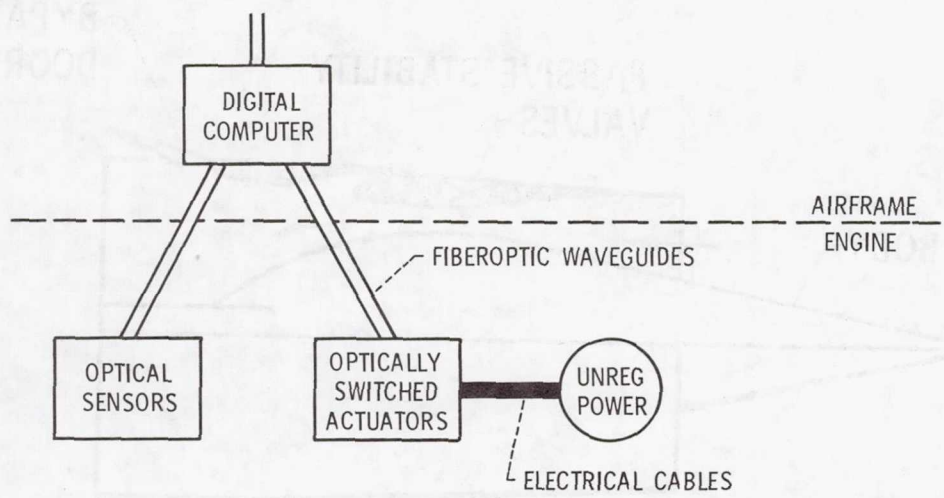

Figure 14.- Digital electronic engine control where computer is mounted off of the engine and fiber-optic waveguides are used for signal transmission.

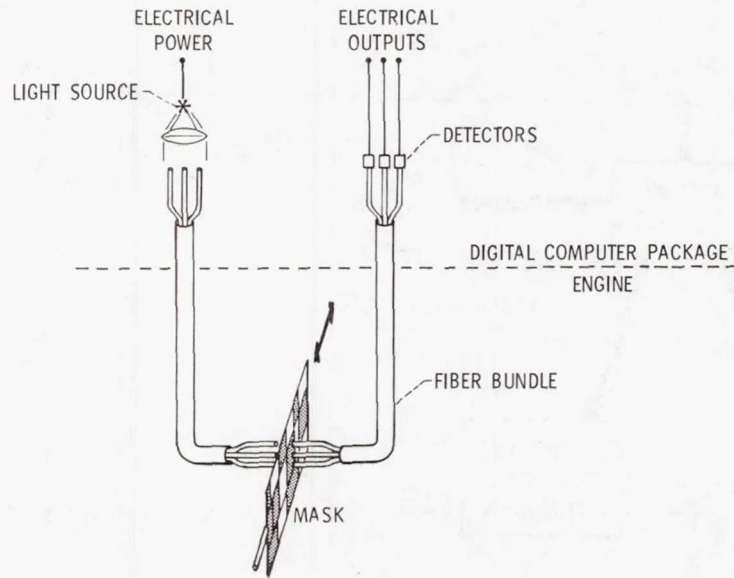

Figure 15.- Fiber-optic-connected position sensor.

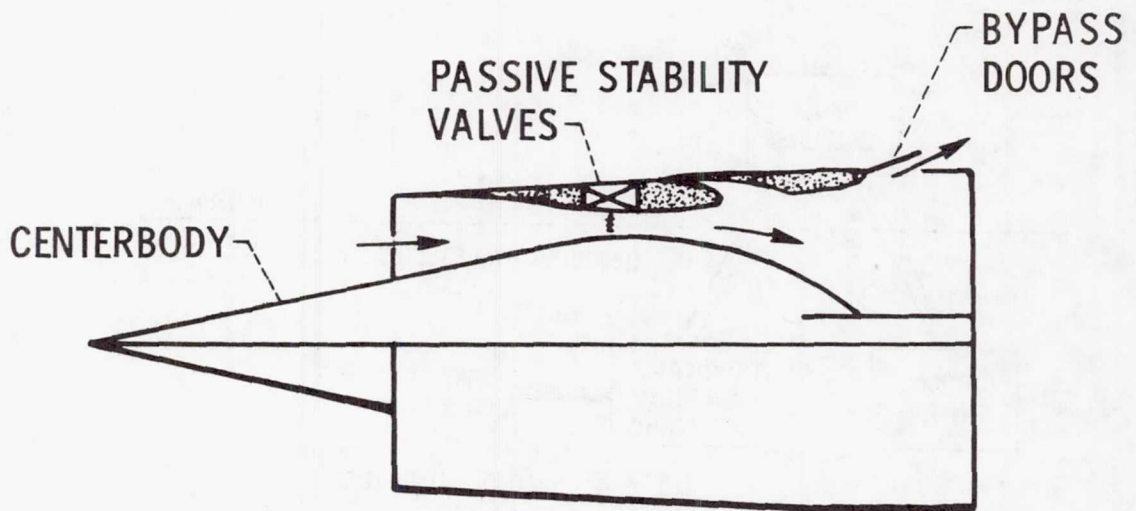

Figure 16.- Supersonic inlet with active and passive controls.

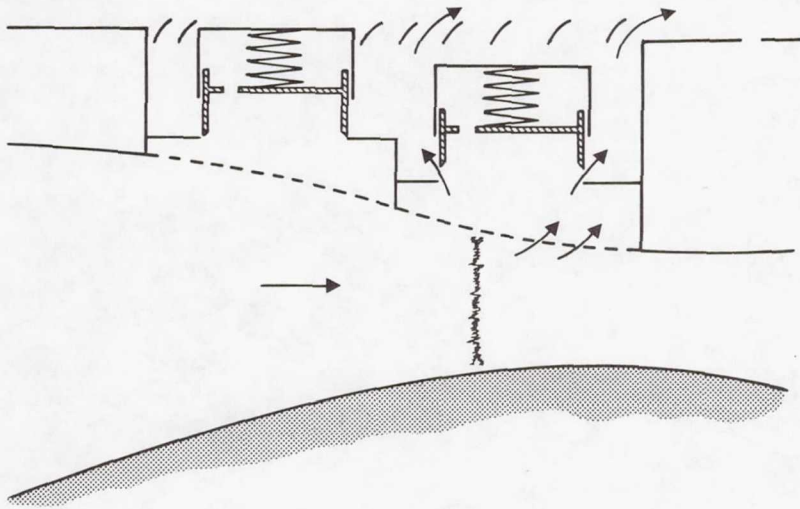

Figure 17.- Operation of inlet with passive stability valves.