

DEVELOPMENT, DOCUMENTATION AND CORRELATION  
OF A NASTRAN VIBRATION MODEL OF THE  
AH-1G HELICOPTER AIRFRAME

J. D. Cronkhite  
Bell Helicopter Textron

SUMMARY

The results of two contracted efforts<sup>1</sup> directed towards evaluating NASTRAN for vibration analysis of the helicopter airframe are presented. The first effort involved development of a NASTRAN model of the AH-1G helicopter airframe and comprehensive documentation of the model so that government personnel could clearly see the techniques and assumptions used in the modeling as well as utilize the model for their own in-house analyses. The next effort was to assess the validity of the NASTRAN model by comparisons with static and vibration tests. In general, the comparisons show good agreement between the NASTRAN results and experimental results. Some problems that were encountered are discussed.

INTRODUCTION

Before the availability of large finite element computer programs, the dynamic behavior of the helicopter airframe was approximated with simple beam analyses. Although not very accurate, these analyses were relatively easy to document and explain to government personnel monitoring a contractor's work. After the development of NASTRAN, and other similar programs, more accurate and representative analyses could be performed. However, before NASTRAN can be executed the helicopter airframe must be represented as a three-dimensional finite element model. This involves modeling assumptions in the idealization of the actual structure as well as generation of a large amount of input data required to describe the structure model. Without clear documentation of these analyses or compatible finite element

---

<sup>1</sup>Work described in this paper was done under U. S. Army Armament Command (ARMCOM) Contract No. DAAF03-73-C-0122 (July 1973 to April 1974) and NASA Contract No. NAS1-13801 (February 1975 to December 1976).

programs, it would be a difficult task for government monitors to check and utilize these analyses. NASTRAN promised to solve this problem by providing adequate analysis capability to satisfy contractors' needs. Also, it was inexpensive, widely used, and available on a variety of computers used at most contractor and government facilities.

A program was initiated by the Army to evaluate NASTRAN as a workable tool for satisfying the needs of industry and the government as well as to develop a useful helicopter airframe model at the same time. The first part of the program was to develop a NASTRAN model of the AH-1G helicopter that would represent the low frequency (below 30 Hertz) vibration characteristics of the airframe. In addition, clear and complete documentation was required so that government personnel could independently make changes to the model and use it for in-house analyses, in particular, response to automatic weapon firing and rotor vibration. Following development and documentation of the NASTRAN model, correlation with static and vibration tests was to be done to assess the validity of the model. Static load deflection testing of the AH-1G fuselage, wings, tailboom and vertical fin was to be used to verify the stiffness modeling and sinusoidal vibration testing, to verify the dynamic characteristics (including both stiffness and mass effects) of the NASTRAN model. The results of this program are discussed in the paper.

## DEVELOPMENT AND DOCUMENTATION OF THE NASTRAN MODEL

### Description of the Model

The NASTRAN model was developed to represent the low frequency (below 30 Hertz) vibration response of the AH-1G helicopter airframe. This is the frequency range of interest for airframe vibration response at predominant main rotor excitation frequencies and response to recoil when firing large caliber, turret-mounted guns from the nose of the helicopter. The mathematical model is a linear elastic representation of the airframe structure with items such as the gun turret, fuel, main and tail rotors and crew modeled as lumped masses. A structure plot of the NASTRAN model developed during the contract is shown in figure 1.

The idealized model is described in detail in reference 1. A brief description of the model is discussed below.

- The fuselage and wing structures are built-up idealizations using primarily rods and shear panels in the bending sections.
- The tailboom is modeled as an elastic line using bar elements. This was done since the tailboom structure

is a semimonocoque structure that can be accurately represented using section properties. In addition, changing the stiffnesses of a few bars to reflect different amounts of effective skin is easier for the NASTRAN user than if it were a built-up model with numerous rod and shear panel elements. The variation in the bar element stiffnesses for various maneuver conditions is tabulated in the documentation report. Most of the other areas of the airframe structure are of sandwich construction where the skins are assumed fully effective.

- The main rotor pylon is idealized as an elastic line using bar elements with scalar springs used to represent the elastomeric isolation mounts at the pylon attachments to the fuselage. MPC's are used to tie the transmission case to the mounts. The landing gear, engine mounting, elevator, vertical tail and tail rotor mast are modeled using bars, rods and MPC's.
- Most of the several thousand weight items in the helicopter are distributed automatically to the grid points of the NASTRAN model by a preprocessing program shown schematically in figure 2. Large weight items and useful weights are distributed separately by the modeler.
- After idealizing the structure into a stiffness model and distributing the weights to grid points, Guyan reduction is used to reduce the number of degrees of freedom to an acceptable analysis size (about 250 degrees of freedom) for the Givens eigenvalue solution.

It was decided that the NASTRAN modeling would involve no special analysis such as DMAPing or require special elements or options such as rigid elements that are available in the MacNeal-Schwendler (MSC) version of NASTRAN but are not available to the public version. This was done so that the NASTRAN input data deck could be used directly at Army and NASA facilities equipped with different computers and public version of NASTRAN, level 15. The model was delivered to the Army in January 1974 and has been run on the CDC 6600 machine at NASA Langley and the IBM 360/65 computer at AVSCOM, St. Louis. This was to show that a model developed by a contractor could be delivered to and used by the contracting Army agency that may have a different computer. In addition, the NASTRAN model has been used for in-house weapon system analyses by ARMCOM.

#### Documentation

Very detailed documentation of the NASTRAN model was provided to the Army in the contract final report, reference 1. One of the

objectives of the documentation was to thoroughly explain the dynamic modeling of the airframe structure to someone in the Army who had a basic understanding of the NASTRAN program. The documentation was also to provide adequate information so that the model could be used independently by the Army and modified for in-house analyses. The government personnel involved felt that these objectives were met.

Some features of the documentation provided to the Army are briefly discussed below:

- The unsorted input data deck itself is well commented and systematically arranged to enable someone familiar with NASTRAN to use the model or modify it with minimum need for reference to the documentation report.
- Modeling philosophy, techniques, and assumptions are discussed in the documentation report.
- The stiffness modeling is described in detail by drawings and sketches organized in a manner similar to the design drawings for the helicopter but depicting the finite element model rather than the actual structure. The model description is broken down into Final Assembly, Major Assembly, Subassembly, and Detail sketches. Structural element descriptions, constraints and omitted degrees of freedom are tabulated and explained on the Detail sketches. Subassemblies of the fuselage major assembly, as well as a typical detail sketch, are shown in figure 3.
- Weights distributed automatically by a preprocessing program and weights distributed separately are discussed.
- A structural element and grid point index serves as a cross reference to locate where an element or grid point is described in the report.
- Finally, a rigid format 3, Normal Modes, sample run is included in the report.

#### CORRELATION

The correlation effort was directed towards assessing the validity of the NASTRAN model in light of the assumptions made, i.e., an elastic structural model aimed at representing airframe vibration below 30 Hertz. Both stiffness and mass modeling are involved in the modeling. It is desirable, but not possible, to correlate each separately. Stiffness modeling can be correlated directly with static load-deflection test data, but mass modeling

can be correlated only indirectly with shake test data which contains both stiffness and mass effects. If correlation is good between analytical and test results for both static and dynamic tests, both stiffness and mass modeling will be judged as good. If static test correlation is good and dynamic test correlation is bad, then the error should be in the mass modeling.

Three sets of tests were conducted in the correlation effort:

1. Static fuselage load-deflection tests done at the Rock Island Arsenal,
2. Static tailboom load-deflection tests done at Bell,
3. Airframe vibration tests done at Bell, but under another contract, Army Contract DAAJ02-C-0105.

The test procedure and results are covered in detail in references 2, 3 and 4, respectively. A summary of test results and details of the correlation with NASTRAN is included in reference 5.

## STATIC TESTING

### Fuselage

Fuselage static testing was done to determine the stiffnesses of the fuselage and wing structures. The test setup is shown in figure 4. Five separate loadings were applied; vertical, lateral and torsion loadings applied to the fuselage and beamwise (vertical) and torsion loadings applied to the wings. For ease of mounting, the fuselage was placed nose up in the fixture and cantilever supported at the aft end. Loads were applied to the nose of the fuselage and at the wing tips.

Deflection data was recorded electrically using linear variable differential transformers (LVDT's). Data was automatically reduced into load versus deflection curves for each measurement location along the fuselage or wing.

When compared to the test results, NASTRAN was consistently about 15% stiffer than the experimental data for all fuselage and wing tests. A typical comparison is shown in figure 5 for the fuselage lateral test. It so happened that the lateral test had to be rerun because of some problems with mislocated instrumentation, but for this test, dial indicators were used rather than LVDT's. The dial indicator data showed somewhat stiffer results than the LVDT data and agreed better with the NASTRAN results. This is shown in figure 5.

Because of the discrepancy in the measurements it was not felt that it was necessary to try to modify the model to agree better with the test results. If the fuselage stiffness was 15% high as indicated with the LVDT measurements, it should be reflected later in the vibration test results. The airframe natural frequencies from the NASTRAN analysis should be about 7% higher than test for modes controlled by the fuselage stiffness.

### Tailboom

Tailboom static testing was done to determine the stiffnesses of the tailboom and vertical fin structures. The tailboom was cantilever supported at the forward end where it attaches to the fuselage and loads were applied separately at the aft end. Six loadings were applied; vertical, lateral and torsion loadings applied at the end of the tailboom and lateral, torsion and chordwise loadings applied at the top of the fin. Deflections were measured using dial indicators except at the support end of the tailboom where electrical measurements were used to record base motions.

Comparisons of the test results with the NASTRAN model using fully effective skin showed very good agreement. A comparison for the tailboom vertical loading condition is shown in figure 6. Conventional methods for calculating effective skin used by stress analysts give results that are much too soft. Experimental work needs to be done to quantify the actual amounts of effective skin for panels under compressive loading. Using the experimental results, analytical methods can be evaluated for calculating effective skin more accurately. Accurate panel stiffness representation can be very important in predicting the vibration characteristics of the airframe structure.

### VIBRATION TEST CORRELATION

The test setup is shown in figure 7. The helicopter was supported by a soft (bungee) suspension system so that the free vibration modes of the airframe would not be affected. Sinusoidal excitation was applied separately at five locations; vertically, laterally and longitudinally at the main rotor hub and vertically and laterally at the tail. A sinusoidal forcing function was applied while sweeping frequency from 0 to 30 Hertz.

For correlation with the NASTRAN model, exciting at the tail was preferred to the hub excitation since the force is applied directly to the airframe structure. When exciting at the main rotor hub, the force is applied through the dynamically complex pylon isolation system and is expected to give questionable

results. The emphasis in this study was to correlate the vibration characteristics of the basic airframe structure.

The data acquisition and reduction procedures are shown in figure 8. Accelerometers measuring response along the airframe feed signals to the on-site data system which is used for monitoring the test and as a check on the off-site results. Response versus frequency plots obtained through the off-site data reduction procedure were used for comparison with the NASTRAN results.

The frequency response information was the basis for the comparison between test and NASTRAN. Overall amplitudes, frequency placement of peak responses (resonances) and general curve shape for response versus frequency data are compared. In addition, forced response mode shapes are compared at response peaks. NASTRAN results were generated using rigid format 11, Modal Frequency Response, to simulate the vibration test.

### Effects of Damping

Structural damping is difficult if not impossible to predict analytically. The amount of modal damping used in the NASTRAN analysis was two percent of critical. This was based on past experience with vibration tests of airframe structures and some studies on the effects of varying damping on the NASTRAN frequency response characteristics.

Damping was varied to see the effects on the shape of the frequency response curves. Values of 0%, 2%, 5% and linear (0% at 0 Hertz to 6% at 30 Hertz) damping were used. Frequency response results using no damping and 2% damping are compared in figure 9. It appears that some small amount of damping should be used in the analysis to smooth out the response of insignificant modes which results in a curve shape more representative of the actual structure.

In design studies, damping should be varied to see the effects on frequency response characteristics. It is sometimes assumed that using a lower value of damping for the analysis is conservative, that is, a higher vibration response would be predicted than would be expected on the actual structure. This is true near resonance, but in the low response frequency ranges (anti-resonances) this would not be true, that is, the response predicted by lower damping would be lower than expected on the actual structure. This is shown in figure 10 where NASTRAN response is compared to test for values of 2% and 5% modal damping.

Low response areas or 'valleys' of the frequency response curve are very important in the helicopter airframe design because it is desired to locate these valleys at rotor excitation

frequencies to minimize vibration. For the Bell two-bladed rotor used on the AH-1G helicopter, the predominant excitation frequency is twice the rotor rpm (two-per-rev).

### Frequency Response

Typical frequency response comparisons of test data with NASTRAN are shown in figure 11. Comments on the comparisons follows:

- Overall magnitude and shape of the response curves agree well especially through 20 Hertz.
- In the 20 to 30 Hertz range, experimental responses at locations that are a considerable distance from the excitation point, such as the pilot seat, tend to drop off indicating some attenuation through the intervening structure. The damping present in the modes in this frequency range also looks considerably higher than the 2% damping used in the NASTRAN analysis. For example, the fuselage torsion/wing yaw mode, indicated on the lateral response curve in figure 11, shows very high peak response near resonance on the NASTRAN curve but there is little peaking on the test curve.
- Peaks agree well through 20 to 25 Hertz except for the second lateral bending mode where NASTRAN is shown to be about 7% lower than test (this is the opposite of what might be expected from the fuselage static test results).
- A comparison of natural frequencies that could be identified from the frequency response results are tabulated below:

#### Vertical Tail Excitation

Mode	Test	NASTRAN
Fore-and-Aft Pylon	3.9	3.0
First Vertical Bending	8.0	8.0
Fuselage Torsion	15.5	15.7
Second Vertical Bending	18.0	17.5



## Lateral Tail Excitation

Mode	Test	NASTRAN
First Lateral Bending	7.1	7.1
Fuselage Torsion	15.5	15.7
Second Lateral Bending	18.9	17.5
Third Lateral Bending	24.4	25.8

- Generally, the tail excitation results agreed well. There was a problem with the hub excitation due to an undesired suspension system or hub fixture mode strongly affecting the test responses.

A comparison of forced response mode shapes at resonance is shown in figure 12. The NASTRAN first vertical bending mode agrees well in frequency and response magnitude with test. The pylon mode frequency from test is considerably higher than NASTRAN (3.9 Hertz compared to 3.0 Hertz). This is probably due to pendulum stiffening of the pylon when suspended from the hub. This would occur in flight also since the helicopter is suspended at the hub by the main rotor. The response of the pylon mode from test is about one fourth of the NASTRAN response. This indicates much higher damping of the pylon mode than the 2% used in the NASTRAN analysis. These effects observed in the pylon dynamics (pendulum stiffening and high damping) should be incorporated in the NASTRAN model.

## CONCLUSIONS

### Development and Documentation

1. It was shown that a rather complex NASTRAN vibration model could be developed by a contractor at his facility and delivered to the Army, to be run on their computer and independently used by them for in-house analysis.
2. The Guyan reduction procedure used to reduce the number of degrees to an acceptable size before using the Givens method was found to be a major difficulty in dynamic modeling. It is also difficult to document and explain why each degree of freedom was omitted. An eigenvalue method such as FEER (reference 6) should be incorporated into NASTRAN that eliminates the need for the Guyan reduction.

3. There were some incompatibilities between the MSC version of NASTRAN that is used at Bell and level 15.1 of the public version which was being used by the Army. The incompatibility that caused the chief problem was that no rigid elements are available in the public version and MPC's or stiff bars had to be used. In addition, for normal modes analysis, MSC NASTRAN was found to be about 2.5 times faster than level 15.1, but this may not be true in level 16.0.

### Correlation

1. When comparing NASTRAN to the fuselage static test results, analysis was consistently about 15% stiffer than experiment. However, one of the test conditions was repeated using a different method of measurement and deflections agreed much better with NASTRAN. The vibration testing did not indicate that the NASTRAN model was stiffer than the actual airframe structure.
2. NASTRAN agreed very well with the tailboom static test results. Fully effective skin on the tailboom panels was used in the analysis. Conventional stress analysis procedures for determining effective skin do not agree with this. Better procedures for determining the effective skin should be developed to determine the stiffness of sheet metal panels under compression load for use in dynamic analyses.
3. Comments on the results of the vibration test comparisons are the following:
  - Damping is difficult to quantify in analysis. A value of 2% modal damping was used for NASTRAN comparison with test. In a helicopter design analysis, damping should be varied to see the effect on the frequency response characteristics, especially in the low response valleys where it is desired to locate excitation frequencies.
  - Frequency response characteristics (magnitude levels, resonance locations, curve shape) agreed well through 20 Hertz when comparing excitation at the tail of the airframe. Above 20 Hertz, test results generally showed more damping than the NASTRAN analysis and indicated attenuation by the structure for locations well removed from the excitation point.
  - Pendulum stiffening and high values of damping of the pylon modes were indicated by test and should be reflected in the NASTRAN model.

## REFERENCES

1. Cronkhite, J. D., Berry, V. L., and Brunken, J. E.:  
A NASTRAN Vibration Model of the AH-1G Helicopter Airframe,  
U. S. Army Armament Command Report No. R-TR-74-045, Research  
Directorate, Gen. Thomas J. Rodman Laboratory, Rock Island  
Arsenal, Rock Island, Illinois, June 1974.
2. Frericks, D. E., et. al.: Measurement of the Static Influence  
Coefficients of the AH-1G Cobra Fuselage, U. S. Army Arma-  
ment Command Report No. R-TR-76-005, February 1976.
3. Slack, J. R.: Static Load Deflection Test of Tailboom  
Installation for AH-1G Helicopter, Bell Helicopter Textron  
Report No. 299-095-003, Bell Helicopter Textron, Fort Worth,  
Texas, December 1975.
4. White, J. A.: Model AH-1G Airframe and Control System Ground  
Vibration Test Results, Bell Helicopter Textron Report  
No. 299-099-819, February 1976.
5. Cronkhite, J. D. and Berry, V. L.: Correlation of AH-1G  
Airframe Test Data with a NASTRAN Mathematical Model,  
Bell Helicopter Textron Report No. 699-099-016, February  
1966.
6. Newman, M. and Pipano, A.: Fast Modal Extraction in NASTRAN  
Via the FEER Computer Program, NASA TM X-2893 NASTRAN:  
User's Experiences, September 1973, pp 485-506.

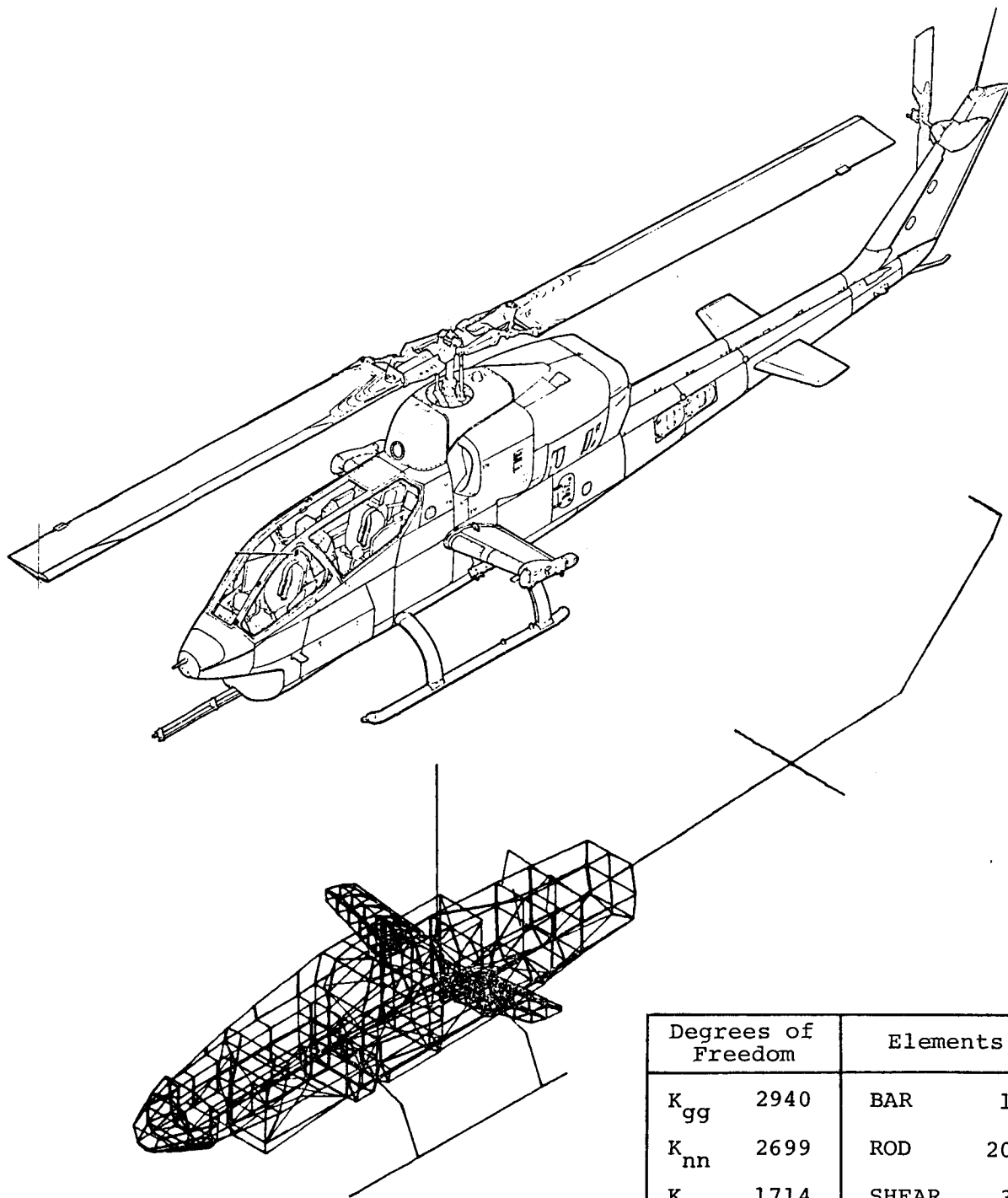

Degrees of Freedom		Elements	
$K_{gg}$	2940	BAR	184
$K_{nn}$	2699	ROD	2013
$K_{ff}$	1714	SHEAR	340
$K_{aa}$	241	QDMEN	160
$K_{ll}$	235	TRMEM	243

Figure 1. NASTRAN Model of the AH-1G Helicopter Airframe.

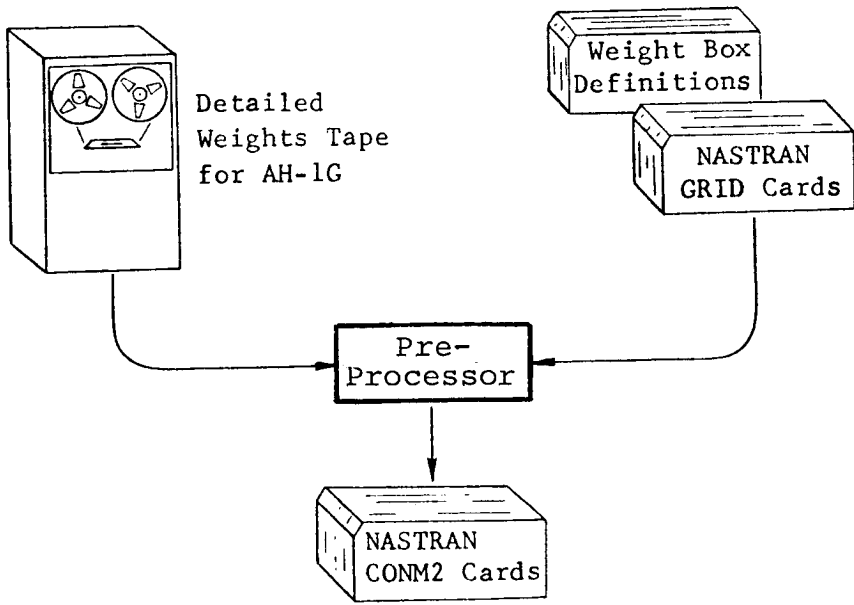
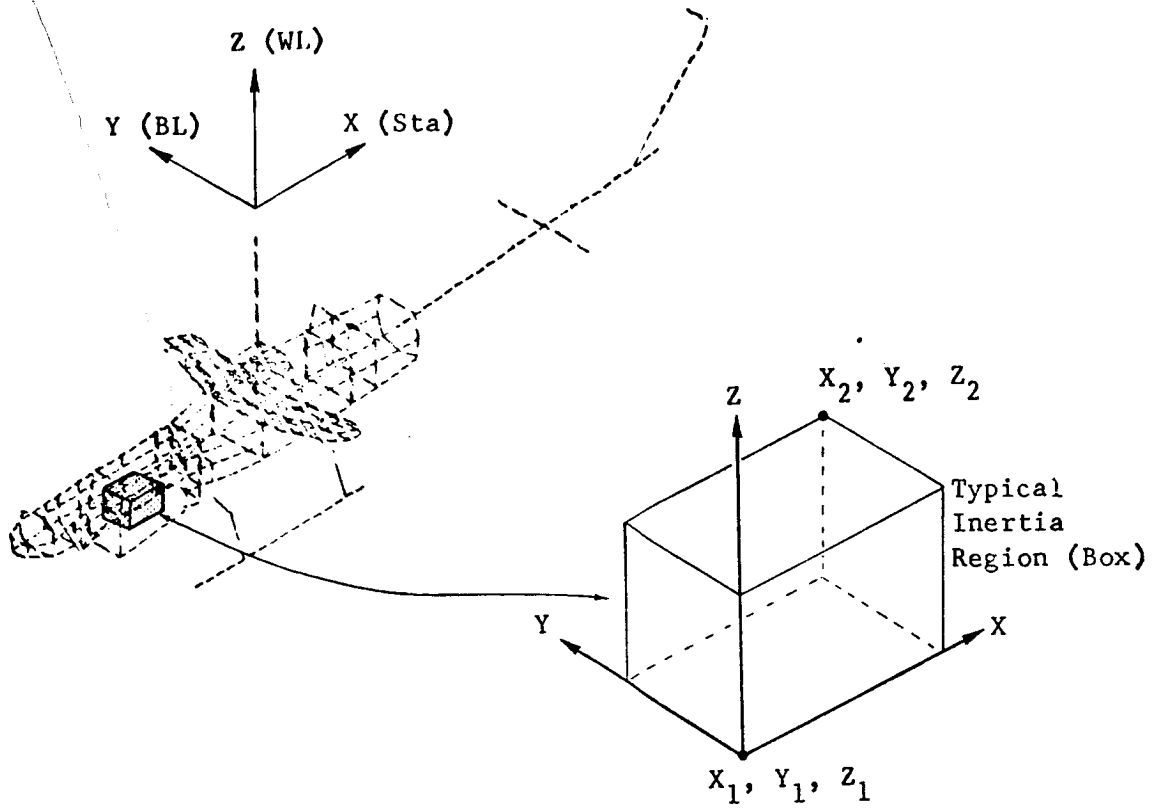
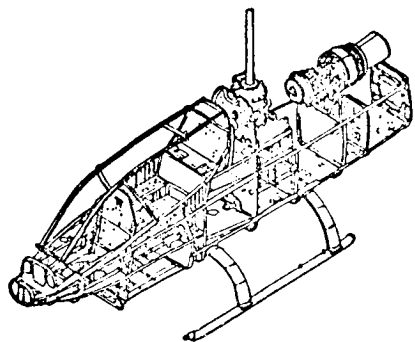
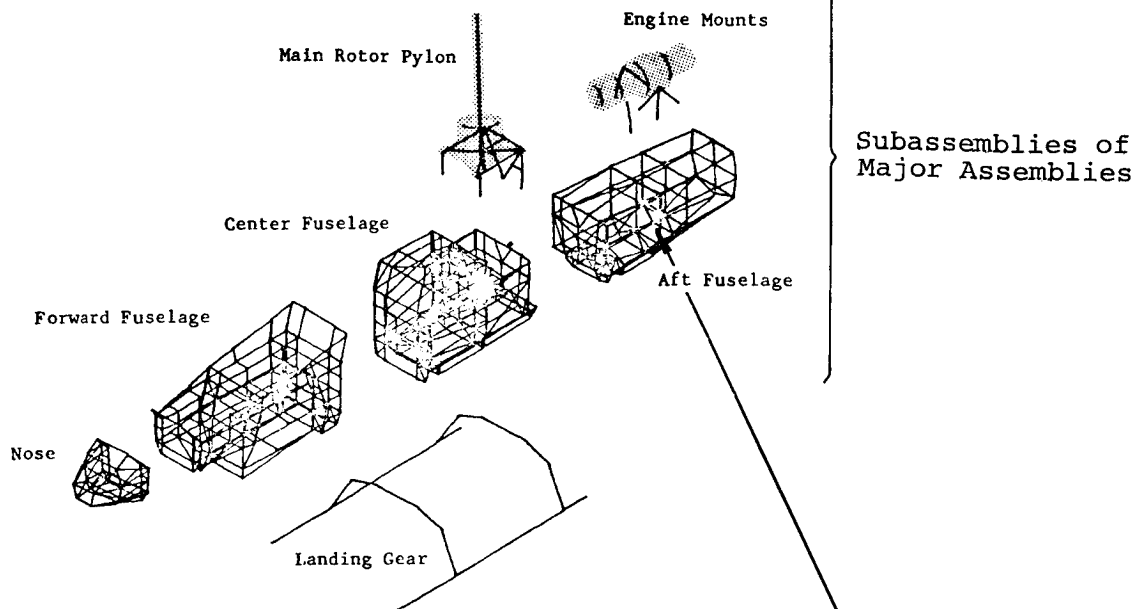

Figure 2. Automatic Weight Distribution Pre-Processor.



Actual Structure  
for Reference



Bulkhead Detail

NOTE: Each element shown in the sketch could represent several NASTRAN elements. Element descriptions and grid point constraints and omits are listed with each detail.

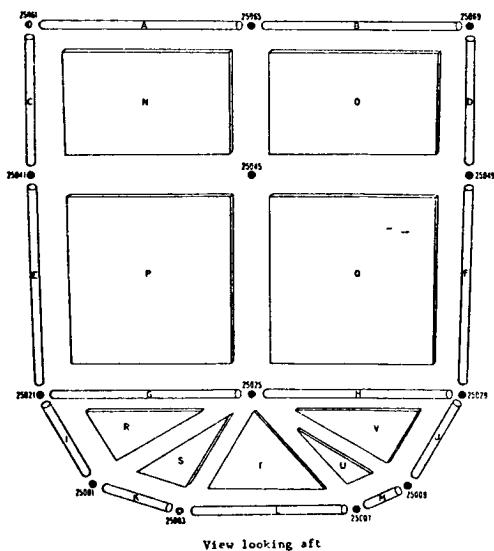

Figure 3. Typical Sketches Used in the Description of the NASTRAN Model.

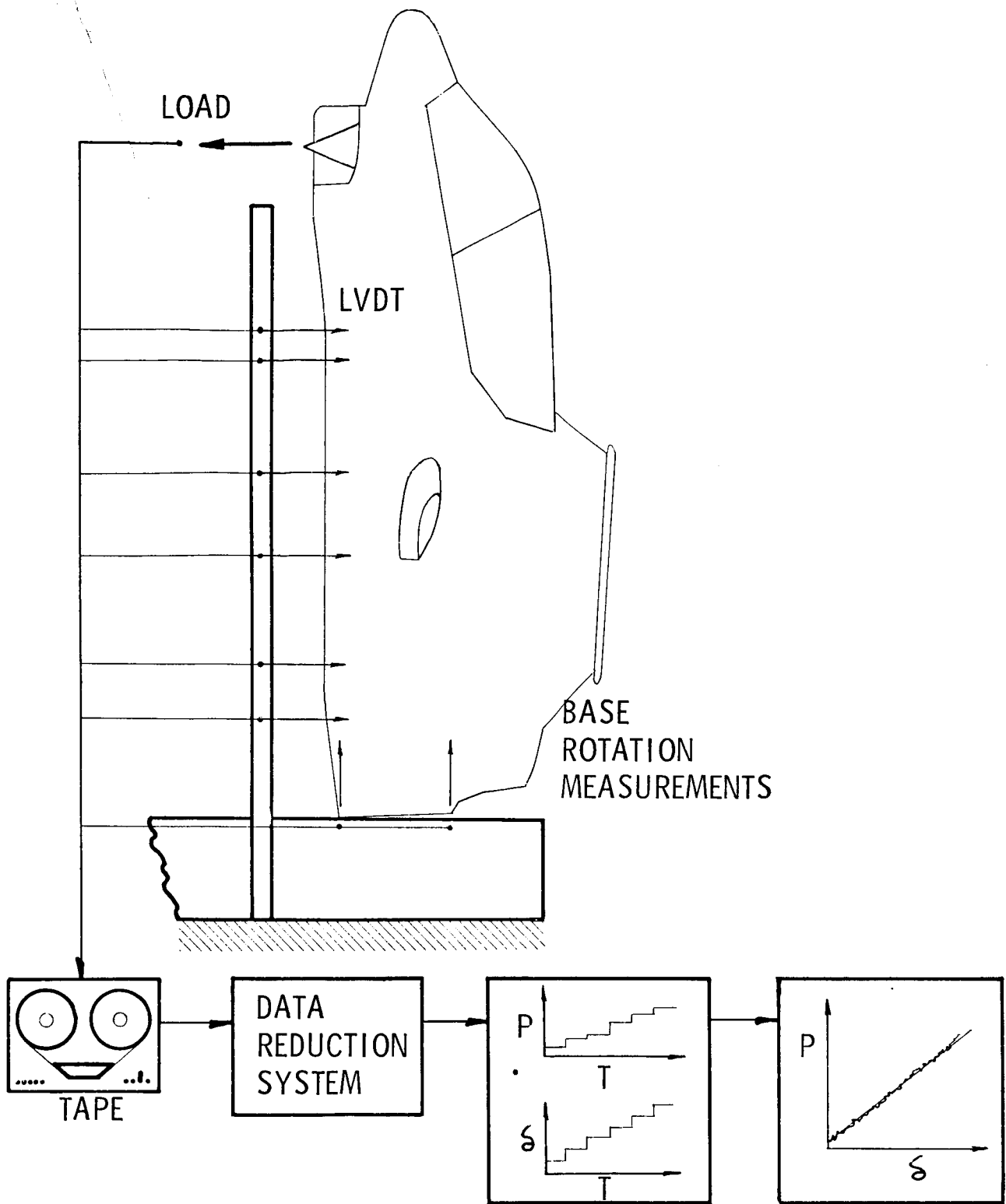

Figure 4. Fuselage Static Test Setup.

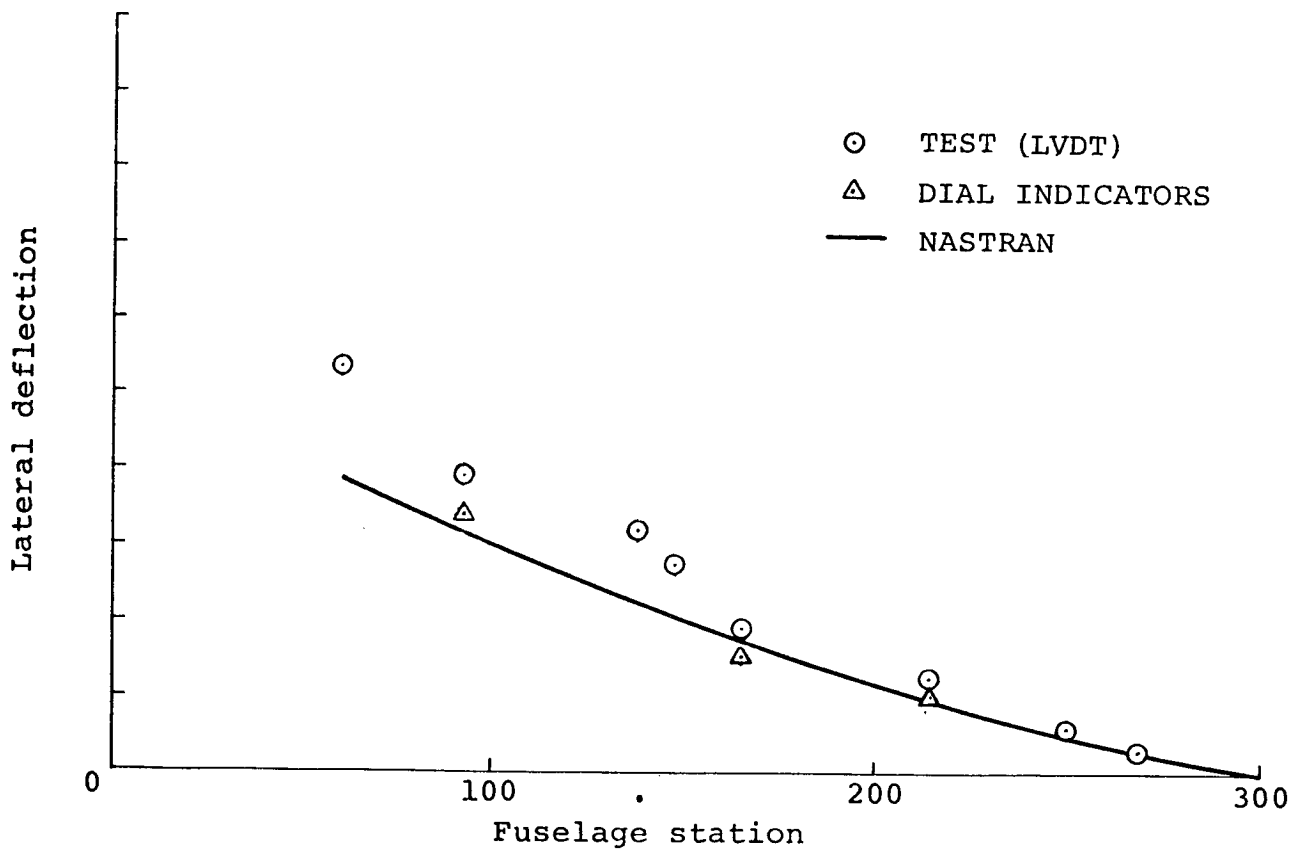
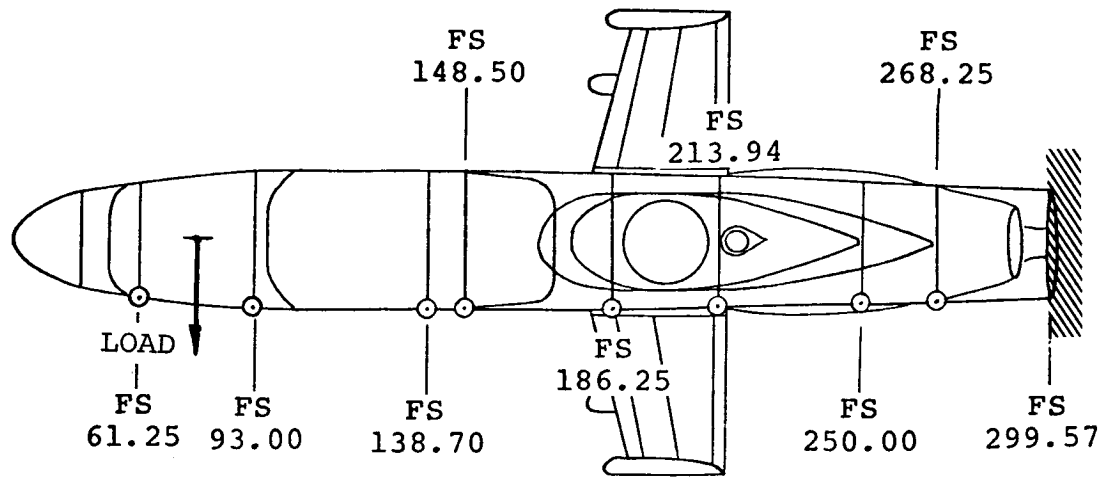

Figure 5. Fuselage Lateral Load-Deflection Comparison.



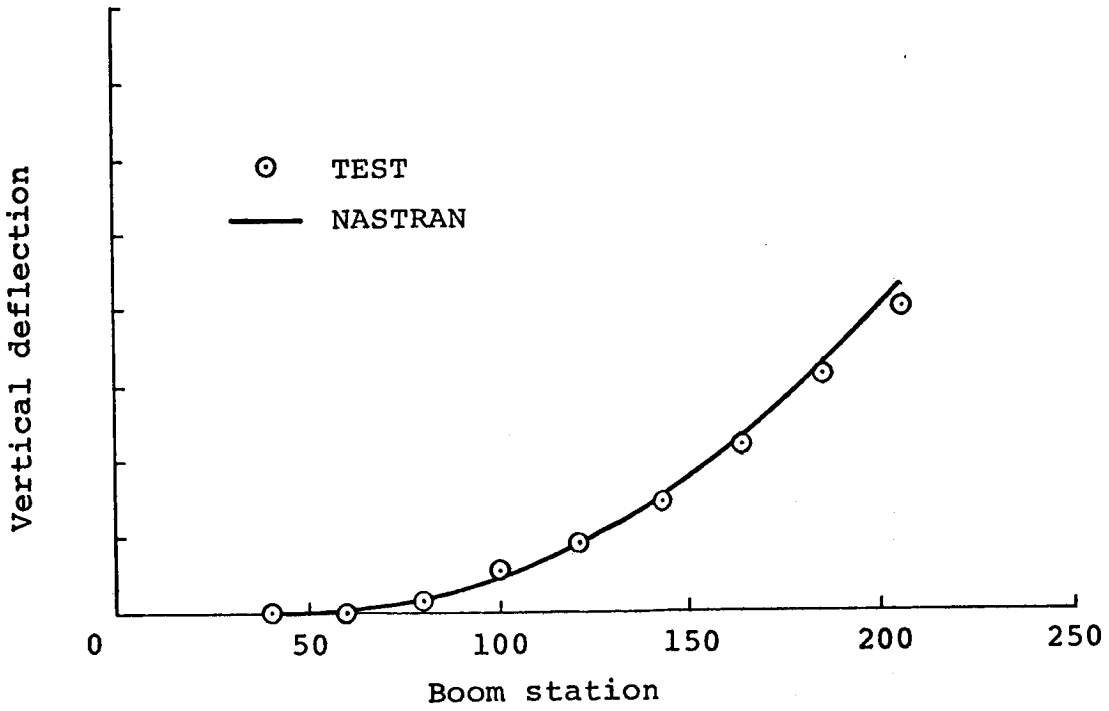
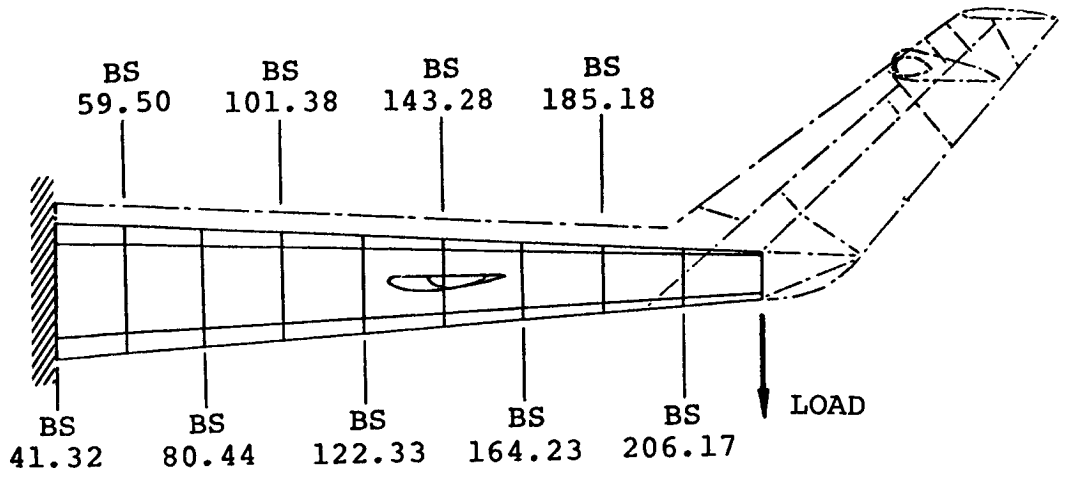

Figure 6. Tailboom Vertical Load-Deflection Comparison.

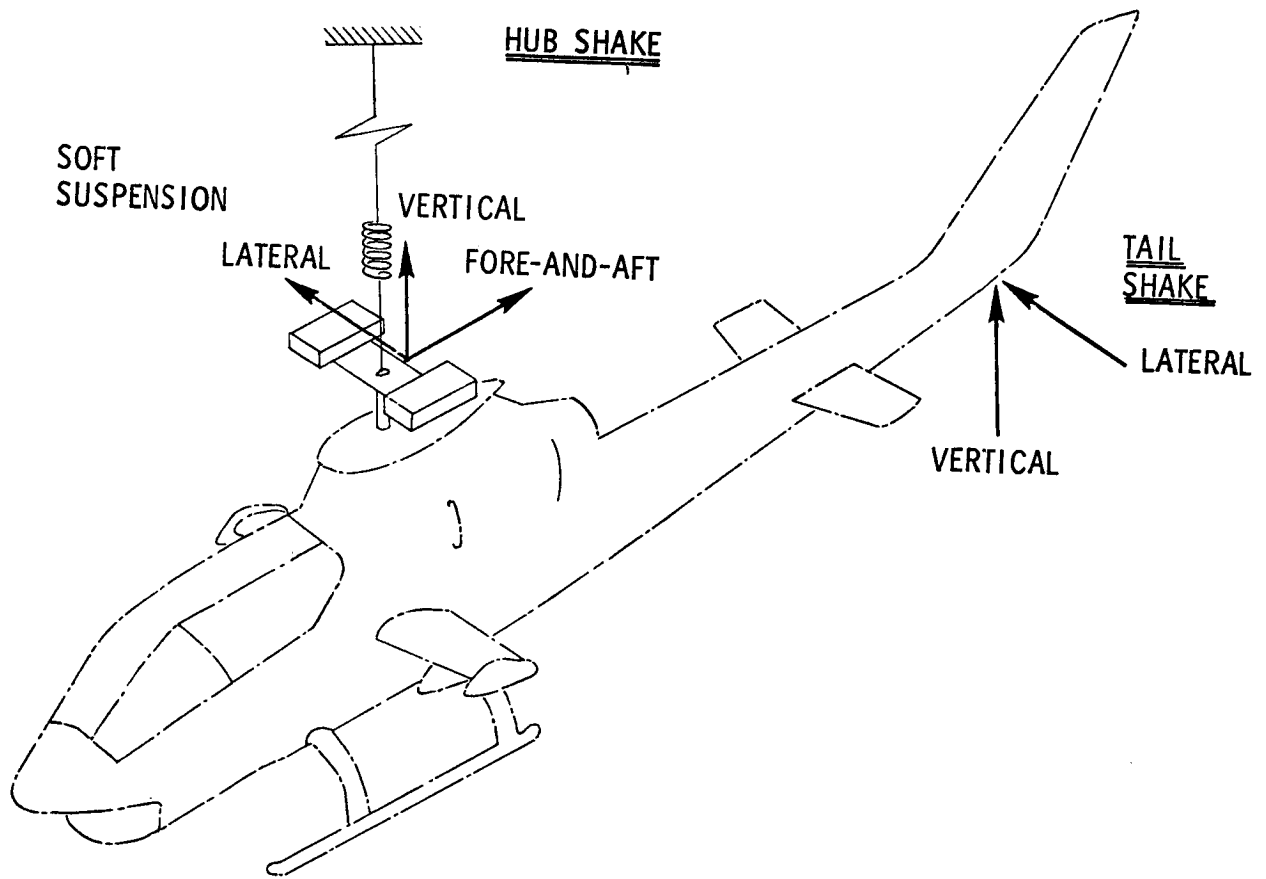

Figure 7. Airframe Sinusoidal Vibration Test Setup.

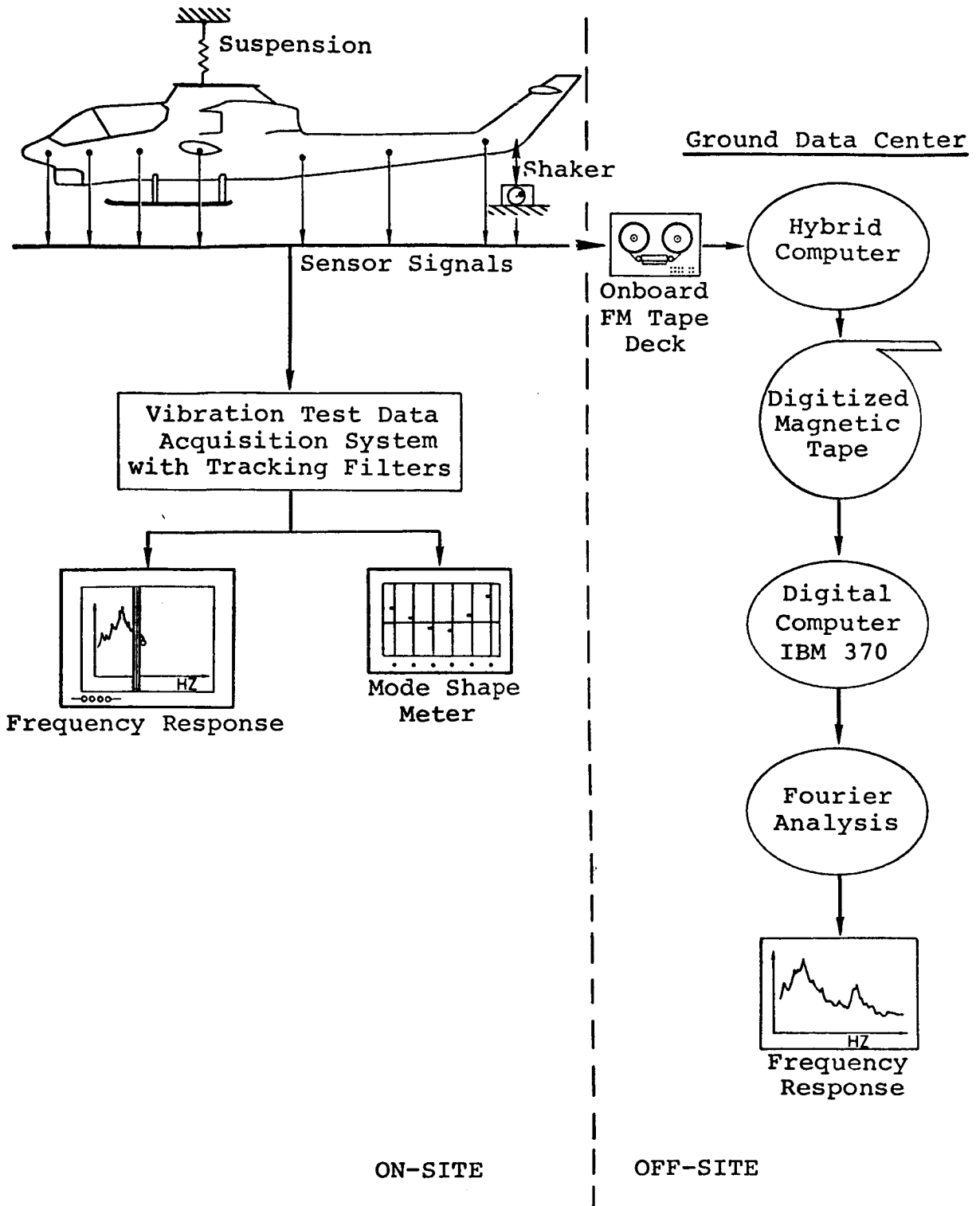

Figure 8. Shake Test Data Reduction Flow Chart.

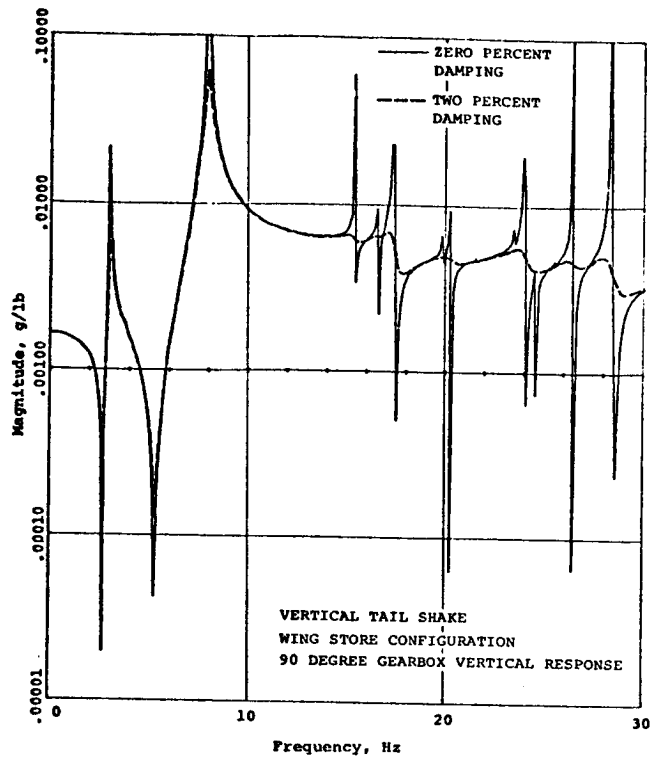
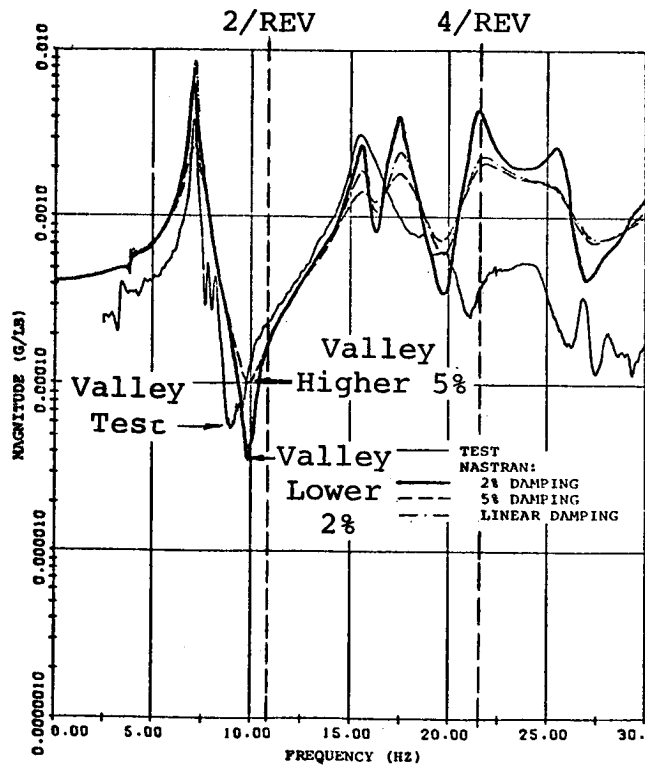
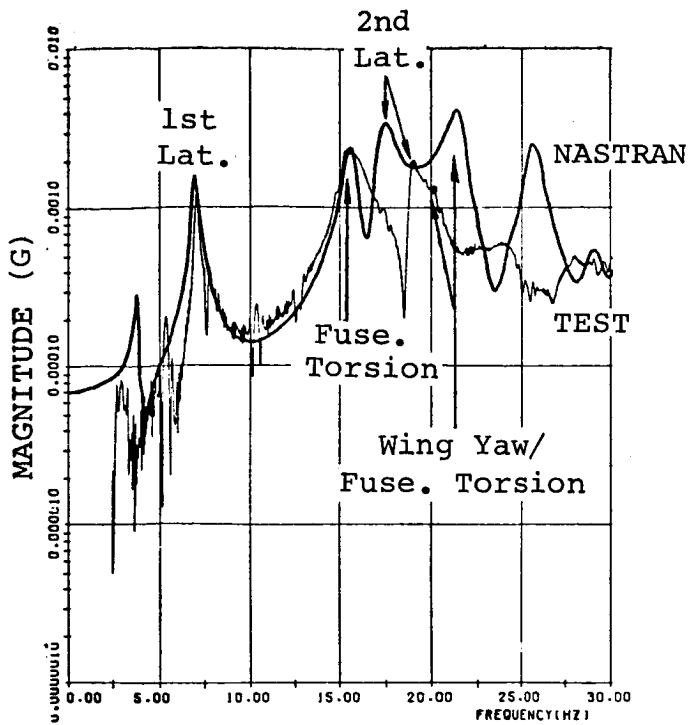

Figure 9. Effect of Damping on Removing Responses of Insignificant Modes.



292 Figure 10. Effect of Damping on Response Valleys.



Pilot Seat Lateral Response to Tail Lateral Excitation.

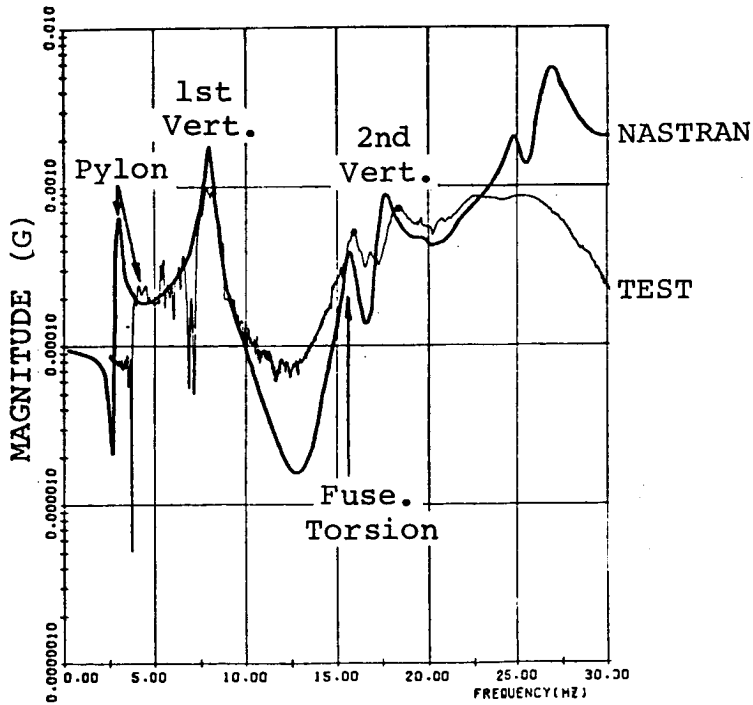

Pilot Seat Vertical Response to Tail Vertical Excitation.

Figure 11. Comparison of Frequency Response Results.

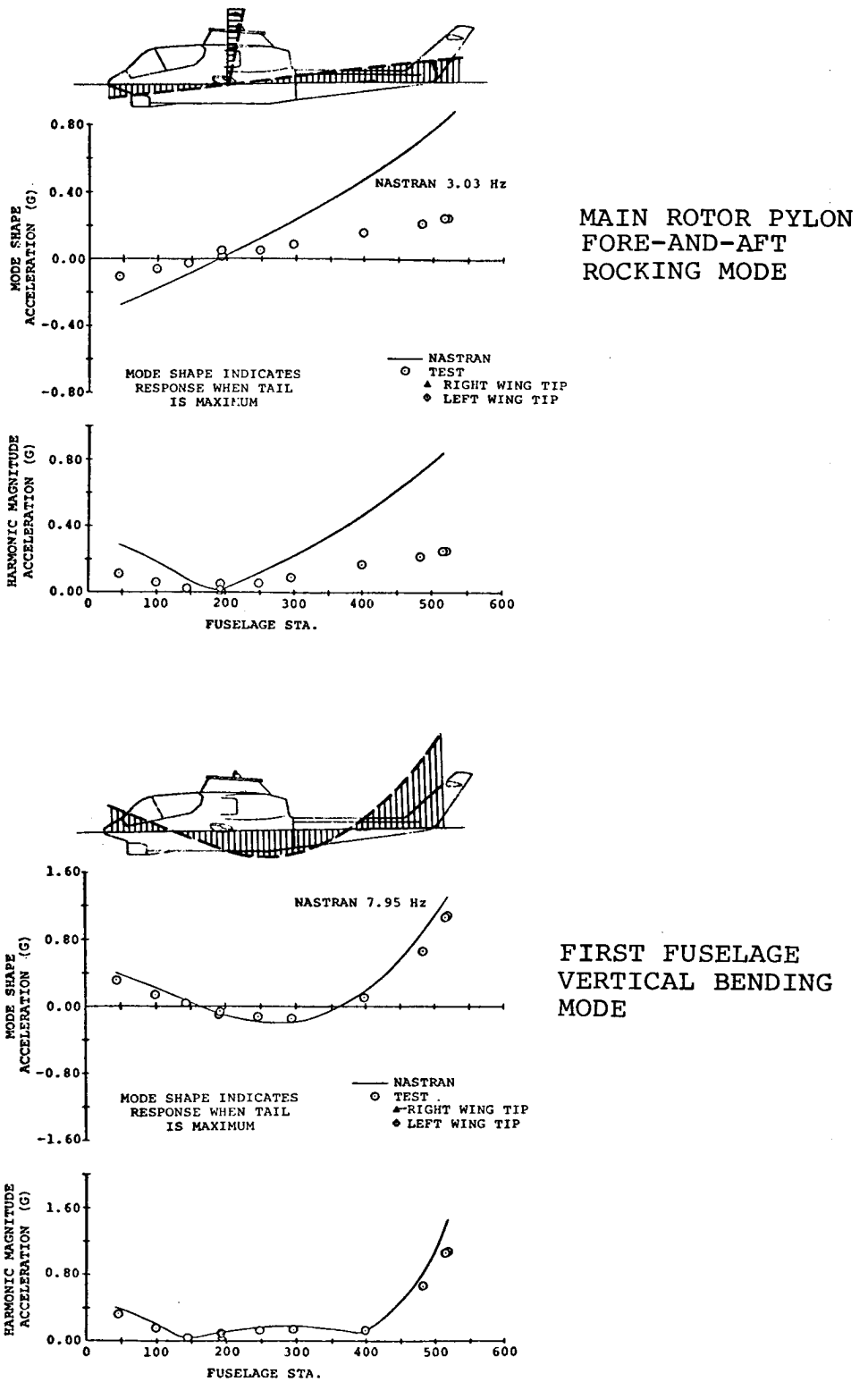

Figure 12. Comparison of Forced Response Mode Shapes.