

General Disclaimer

One or more of the Following Statements may affect this Document

- This document has been reproduced from the best copy furnished by the organizational source. It is being released in the interest of making available as much information as possible.
- This document may contain data, which exceeds the sheet parameters. It was furnished in this condition by the organizational source and is the best copy available.
- This document may contain tone-on-tone or color graphs, charts and/or pictures, which have been reproduced in black and white.
- This document is paginated as submitted by the original source.
- Portions of this document are not fully legible due to the historical nature of some of the material. However, it is the best reproduction available from the original submission.

SPACE TRANSPORTATION SYSTEM/CARGO MASS PROPERTIES
CALCULATION USING AN INTERACTIVE SYSTEM

CR 151437

Job Order 44-139

(NASA-CR-151437) SPACE TRANSPORTATION
SYSTEM/CARGO MASS PROPERTIES CALCULATION
USING AN INTERACTIVE SYSTEM (Lockheed
Electronics Co.) 35 p HC A03/MF A01

N77-27171

CSCS 22A G3/16

Unclas
36717

Prepared By

Lockheed Electronics Company, Inc.
Systems and Services Division
Houston, Texas

Contract NAS 9-15200

For

EXPERIMENT SYSTEMS DIVISION

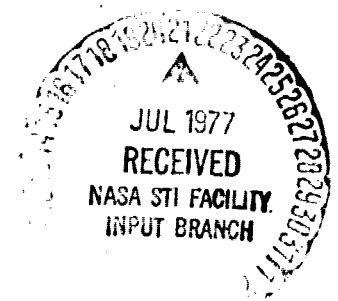

National Aeronautics and Space Administration
LYNDON B. JOHNSON SPACE CENTER
Houston, Texas

June 1977

LEC-10705
SEPO-139-32

SPACE TRANSPORTATION SYSTEM/CARGO MASS PROPERTIES
CALCULATION USING AN INTERACTIVE SYSTEM

Job Order 44-139

PREPARED BY



G. G. Downs, Staff Engineer
Applied Mechanics Department, LEC/SSD

APPROVED BY

LEC/SSD

NASA/JSC



R. R. Miloy, Task Leader
Scientific Applications Branch



E. L. Newsome, Task Manager
Experiment Systems Division

CONCURRENCE

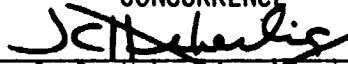

J. C. Heberlig, Manager
STS Utilization Planning Office

Prepared By

Lockheed Electronics Company, Inc.

For

Experiment Systems Division

NATIONAL AERONAUTICS AND SPACE ADMINISTRATION
LYNDON B. JOHNSON SPACE CENTER
HOUSTON, TEXAS

June 1977

TECHNICAL REPORT INDEX/ABSTRACT
(See instructions on reverse side.)

1. TITLE AND SUBTITLE OF DOCUMENT Space Transportation System/Cargo Mass Properties Calculation Using an Interactive System	2. JSC NO. JSC-12635
---	--------------------------------

3. CONTRACTOR/ORGANIZATION NAME LEC/SSD	4. CONTRACT OR GRANT NO. NAS 9-15200
---	--

5. CONTRACTOR/ORIGINATOR DOCUMENT NO. LEC-10705	6. PUBLICATION DATE (THIS ISSUE) June 16, 1977
---	--

7. SECURITY CLASSIFICATION Unclassified	8. OPR (OFFICE OF PRIMARY RESPONSIBILITY) ED4
---	---

9. LIMITATIONS GOVERNMENT HAS UNLIMITED RIGHTS <input checked="" type="checkbox"/> YES <input type="checkbox"/> NO IF NO, STATE LIMITATIONS AND AUTHORITY	10. AUTHOR(S) G. G. Downs and R. R. Miley
---	---

11. DOCUMENT CONTRACT REFERENCES WORK BREAKDOWN STRUCTURE NO. CONTRACT EXHIBIT NO. DRL NO. AND REVISION DRL LINE ITEM NO.	12. HARDWARE CONFIGURATION SYSTEM SUBSYSTEM MAJOR EQUIPMENT GROUP
---	--

13. ABSTRACT Description of the methodology used by the NASA/JSC Experiments and Payloads Project Office, Experiment Systems Division, and the STS Utilization Planning Office, Shuttle Payload Integration and Development Program Office, to perform STS cargo mass properties calculations using an interactive computer system.

14. SUBJECT TERMS		
_____	_____	_____
_____	_____	_____
_____	_____	_____

CONTENTS

<u>Section</u>	Page
1. INTRODUCTION.	1
1.1 <u>PURPOSE</u>	1
1.2 <u>OBJECTIVES</u>	1
1.3 <u>SCOPE</u>	1
2. PLANNING AND ANALYSIS PROCESS	2
2.1 <u>STS 100 FORM</u>	2
2.2 <u>FLIGHT REQUIREMENTS</u>	2
2.3 <u>PAYLOAD CHARACTERISTICS</u>	5
2.4 <u>PAYLOAD ACCOMMODATIONS</u>	5
2.5 <u>STANDARD STS SERVICES</u>	5
2.6 <u>PAYLOAD CHARGEABLE ITEMS</u>	7
2.7 <u>COMBINE STANDARD STS SERVICES AND PAYLOAD CHARGEABLE ITEMS</u>	7
2.8 <u>SHUTTLE MASS PROPERTIES DATABASE</u>	7
2.9 <u>MASS PROPERTIES PROGRAM</u>	8
2.10 <u>COMPOSITE ORBITER MASS PROPERTIES</u>	8
2.11 <u>ITERATE</u>	8
2.12 <u>DOCUMENT RESULTS</u>	9
3. EXAMPLES.	9
3.1 <u>SPACELAB 1 (LONG MODULE AND PALLET)</u>	9
3.2 <u>TDRS/2-STAGE IUS AND SBS/SSUS D</u>	9
4. ILLUSTRATIONS OF PROGRAM USAGE.	10
4.1 <u>INITIAL ANALYSIS REQUIRING FURTHER CHANGES</u>	10
4.2 <u>EFFORT REQUIRED TO PERFORM ANALYSIS</u>	10
5. REFERENCES.	10

Appendix	Page
A. MASS PROPERTIES CALCULATION FOR SPACELAB 1 (LONG MODULE AND PALLET)	A-1
B. MASS PROPERTIES CALCULATION FOR MULTIPLE CARGO (TDRS/2-STAGE IUS AND SBS/SSUS D)	B-1

TABLE

Table	Page
I ORBITER MASS PROPERTIES	6

FIGURES

Figure	Page
1 Operator interactive overview	3
2 Mass properties calculation	4

SPACE TRANSPORTATION SYSTEM/CARGO MASS PROPERTIES CALCULATION USING AN INTERACTIVE SYSTEM

1. INTRODUCTION

This paper was developed in response to Job Order 44-139, Experiments and Payloads Project Office, Experiment Systems Division, dated October 29, 1976. It is a description of the mass properties methodology implemented to accomplish Space Transportation System (STS) engineering analysis and planning, and to perform compatibility assessment studies of various integrated STS payloads and carrier configurations.

1.1 PURPOSE

To describe the methodology used by the NASA/JSC Experiments and Payloads Project Office, and the STS Utilization Planning Office, Shuttle Payload Integration and Development Program Office, to perform STS cargo mass properties calculations using an interactive computer system.

1.2 OBJECTIVES

- a. Describe the method for the STS cargo mass properties calculation in support of the STS Utilization Planning effort.
- b. Illustrate with examples the mass properties calculation for specific payloads.

1.3 SCOPE

This paper will discuss the planning and analysis process requirements and techniques, the interactive computer system and database, and the effort required to perform the mass properties calculation.

2. PLANNING AND ANALYSIS PROCESS

The Shuttle will provide space transportation services for the scientific user community, commencing with the June 1980 time frame. Specific flight phases that are adaptable to payload needs on each flight are various orbital maneuvers, rendezvous, deployment, retrieval, and on-orbit servicing. As part of the STS Utilization Planning function, each proposed flight is assessed to ensure cargo/Shuttle feasibility, compatibility, and operation within the STS performance and constraints limitations. This paper describes the techniques, capability, and methodology used by the STS Utilization Planning Office in assessing a proposed flight cargo by determining the individual payload and composite cargo location, and calculating the composite mass properties of the cargo and Orbiter vehicle. An overview of this process is illustrated in figure 1.

The STS Utilization Planning and Analysis process for mass properties is illustrated in the block diagram/flowchart, figure 2. A functional description of each block follows.

2.1 STS 100 FORM

Assignment on an STS flight is obtained through initiating a request for flight assignment (STS 100 Form) and subsequent planning and negotiations with the STS Operations Office at NASA Headquarters. Specific payload characteristics, mass properties, and unique requirements and constraints are identified by the user on this form. The STS User Handbook is a guide to initiating a request for flight assignment (ref. 1). The user's handbook provides information on NASA STS management and procedures, STS flight systems, STS launch and landing operations, and STS flight operations.

2.2 FLIGHT REQUIREMENTS

The flight purpose, requirements, launch direction, orbit, operational environment, etc., are evaluated to determine orbiter dry weights, consumables, personnel, flight kits and special equipment or requirements, which in turn drive the vehicle configuration.

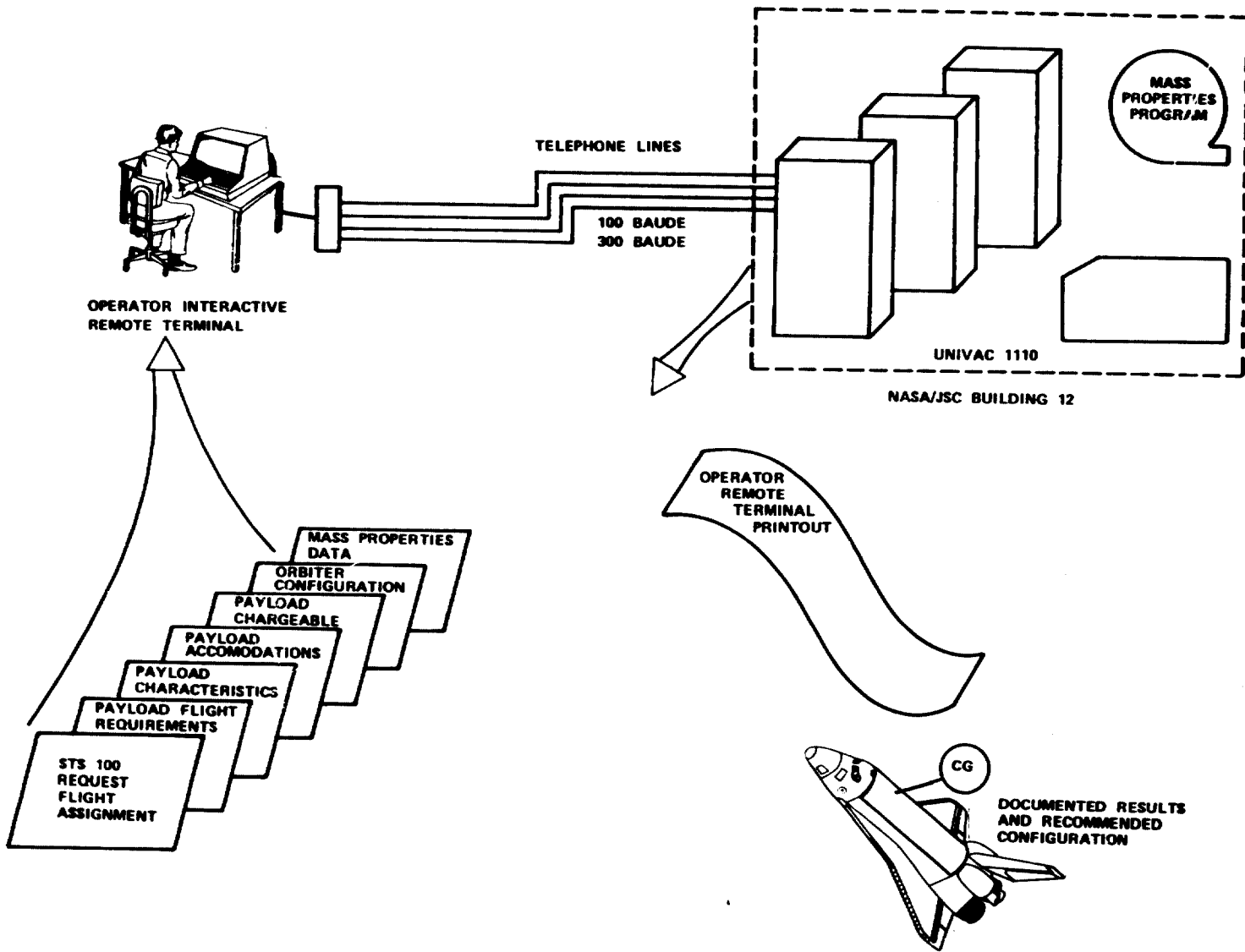

Figure 1.- Operator interactive overview.

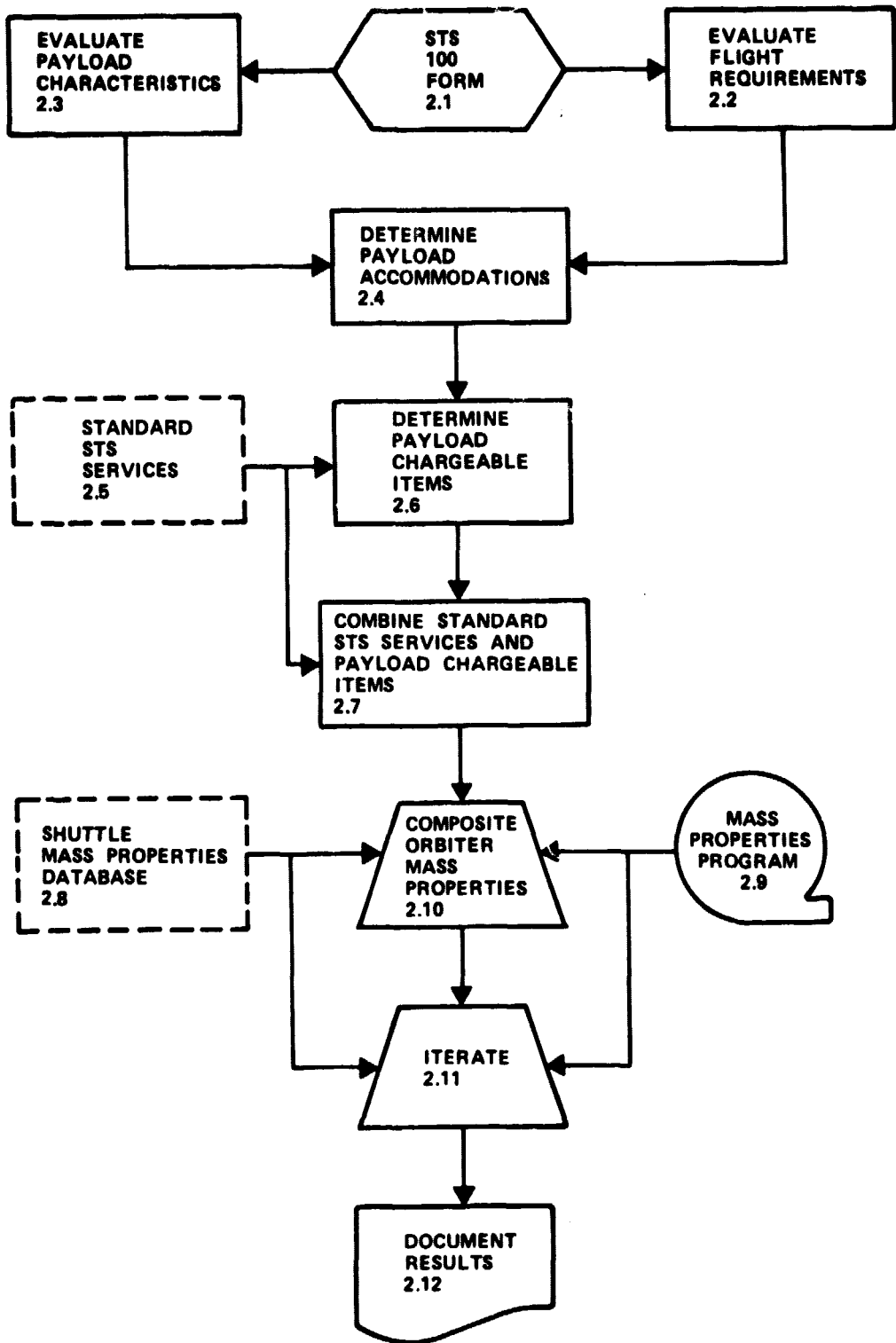

Figure 2.- Mass properties calculation.

2.3 PAYLOAD CHARACTERISTICS

Payload characteristics are identified by the user on the STS 100 Form and through additional documentation as necessary. This information is used to determine payload mass properties, physical dimensions, placement within the Orbiter, interfaces with Orbiter services, additional flight kits, and consumables.

2.4 PAYLOAD ACCOMMODATIONS

Subsequent to flight requirements and payload characteristics evaluation, the payload is tentatively assigned to an STS flight. Additional payloads following the same evaluation procedure may be assigned to the same proposed STS flight. At this point, the individual payloads are located within the orbiter payload bay forming a proposed cargo configuration for this particular STS flight.

Once the payload location is selected (to obtain a composite vehicle CG) payload attach points and hardware fittings (keel, bridges, longerons) are determined. The fittings required are dependent upon payload location points. The physical dimensions of the payloads and the available attach points influence payload location. A composite mass properties calculation is made of the payload and payload hardware, which in turn is used in the composite vehicle/cargo mass properties calculation.

2.5 STANDARD STS SERVICES

The standard STS flight configuration and services capability is based on 1-day flight operations, a three-man flight crew, the standard vehicle dry weights, and required consumables to achieve the aforementioned performance. A mass properties breakdown of this detail for standard STS services is illustrated in table I. Table I tabulates the Orbiter 102 weights, CG, and performance data applicable to a 28.5° inclination and a 160-nmi circular orbit. For purposes of illustration and lack of availability of more specific data, table I data is used for the SPACELAB 1 example, which requires a 57° inclination and a 160-nmi circular orbit.

Table I.
ORBITER MASS PROPERTIES

	WT	X	Y	Z	
OV-102 OFT-1 INERT	140,000	1056.5	0.9	368.8	
PAYLOAD BAY LINER INSTALLATION	101	942.0	0	340.	
PAYLOAD BAY LINER	254	942	0	340	
RMS INSTALLATION	260	866	-83.5	444.1	
RMS	920	866	-83.5	444.1	
SEAT RECONFIGURATION	110	506	0	452.4	
PAYLOAD INTERROGATOR	60				
PAYLOAD DATA INTERLEVER	36				
SIGNAL PROCESSOR	42				
KU BAND INSTALLATION	337	550	90	480	
OFT OV-102 INERT	142,120	1056.5	.4	369.7	
SSME X3 INERT	19,479	1491.9	-.1	383.6	
EPS TANK SET 3	735	1010.	-4	297	
PERSONNEL (3 CREWMEN; 1-3 DAY FLIGHT)	2,013	504.3	.9	380.2	
SUBTOTAL (3 CREWMEN, 3 EPS TANKS, 1-3 DAYS)	22,227	1380.1	-.1	380.4	
ORBITER WITHOUT CARGO & CONSUMABLES	164,347	1097.1	.3	371.2	
NONPROPULSIVE CONSUMABLES	5,220	1003.3	-4.6	337.4	- 2,668
MPS PROPELLANT	5,206	1408.5	12.9	355.2	- 4,500
OMS PROPELLANT	25,104	1417	0	475.8	-23,444
RCS PROPELLANT	7,374	1004.2	2.	434.3	- 5,757
SUBTOTAL	42,904	1294.7	1.3	437.2	-36,369
▽ ORBITER PRELAUNCH (3 CREW, 3 EPS TKS, 1-3 DAYS)	207,251	1138.5	.5	384.8	
CONSUMED TO EI	-36,369	1320.3	1.6	444.2	
② ORBITER AT EI (3 CREW, 3 EPS TANKS. 1-3 DAYS)	170,882	1099.8	.3	372.2	

2.6 PAYLOAD CHARGEABLE ITEMS

In addition to the standard STS services, some payloads will require additional payload chargeable items. Some of the requirements which determine these items are special vehicle hardware, equipment, or services not included as part of the standard services, i.e., special orbit requirements, special flight operations, or additional flight crew support. Appendix A, form NASA-S-77-2533C, summarizes the more common of these additional payload chargeable items.

2.7 COMBINE STANDARD STS SERVICES AND PAYLOAD CHARGEABLE ITEMS

A composite Orbiter vehicle consists of the cargo (everything contained in the payload bay plus any equipment located elsewhere in the Orbiter which is user unique and not carried in the standard baseline Orbiter weight budget) plus the standard Orbiter vehicle. The Mass Properties Calculation step 2.10 (reference figure 2) is based upon this composite Orbiter vehicle.

2.8 SHUTTLE MASS PROPERTIES DATABASE

The Shuttle program's mass properties database is utilized for mass properties calculations for all established vehicle weights and constraints and is supplemented as necessary with proposed payloads data, carriers, and any items not controlled by the Shuttle office.

The mass properties calculations are dependent upon the availability of accurate, complete weights data. A Shuttle weights database has been established and is controlled and maintained by the Shuttle program office (references 2 and 3).

The data is available under major groupings, e.g., Orbiter, External Tank, Solid Rocket booster, Space Shuttle Main Engine, flight kits, and payload weight chargeable options. Subgrouping mass properties data is also available, i.e., Orbiter 102 Inert Summary Weight Statement, personnel, and cabin stowed equipment.

2.9 MASS PROPERTIES PROGRAM

The interactive program utilized in the mass properties calculation is a routine of the ELDON program, which in turn is used to determine Orbital Maneuvering System (OMS) and Reaction Control System (RCS) fuel requirements for an individual mission. The routine is called as necessary by the ELDON program. This routine MSPROP takes an input from the user at the terminal (weight, CG, in X, Y, Z STS coordinates, and moments of inertia (optional)) and sums it with the previous inputs and returns to the user a new composite vehicle/cargo weight, CG, and moments of inertia.

2.10 COMPOSITE ORBITER MASS PROPERTIES

Mass properties are calculated for each payload, the total cargo, and the composite Orbiter vehicle.

The general approach taken in the mass properties calculation is as follows. Two basic computations are made, to determine:

- a. The entry interface (EI) weight (down weight) which occurs at 400,000 ft as the Orbiter returns to land. The vehicle has a maximum composite entry weight and CG limit.
- b. Return-to-launch-site (RTLS) and abort-once-around (AOA). The RTLS calculation is made using the prelaunch vehicle weight (wet) less an allowance for fuel consumption and OMS/RCS fuel dumped. The AOA calculation deletes additional fuel and has the same constraints as for RTLS.

2.11 ITERATE

In the event the operational constraints are not met, changes are made directed toward correcting the problem area, through shifting payloads to different CG positions, reducing payload weights, or ballasting as necessary. The mass properties calculation is then made again to verify acceptable performance, and repeated as necessary.

2.12 DOCUMENT RESULTS

The results of the analysis, assumptions, and recommended vehicle configuration are documented on forms designed to show flight assignment of a payload and the resulting composite vehicle mass properties (Appendixes A and B).

3. EXAMPLES

3.1 SPACELAB 1 (LONG MODULE AND PALLET)

An example of the mass properties calculation for a single payload is developed in Appendix A. The payload location, CG, and weight are shown on pages A-3 and A-4. Composite weights with attachment hardware are shown for the SPACELAB and tunnel plus pallet. Both up and down weights are given. The backup sheets, (pages A-5 through A-7) give the payloads, attachment points and hardware with weights and CG. Page A-8 illustrates the additional payload chargeable items (flight kits, personnel, etc.). An annotated computer print-out of the mass properties calculation is shown on page A-9.

3.2 TDRS/2-STAGE IUS AND SBS/SSUS D

The mass properties calculation for a multiple cargo composed of a Tracking and Data Relay Satellite (TDRS) boosted by an Interim Upper Stage (IUS) and a Systems Business Satellite (SBS) boosted by a Spinning Solid Upper Stage Delta class spacecraft (SSUS D) is developed in Appendix B. The placement of these two payloads is illustrated on page B-4 and the mass properties of each payload are shown respectively on pages B-6 and B-7. The computer printout of the mass properties calculation combining the two payloads and the standard Orbiter vehicle is annotated on page B-8. The calculation is performed to determine the mass properties first at entry interface using the "Orbiter at EI" value from table I marked ② and then second at RTLS and AOA using the Orbiter Prelaunch value marked ▽.

4. ILLUSTRATIONS OF PROGRAM USAGE

4.1 INITIAL ANALYSIS REQUIRING FURTHER CHANGES

The initial placement of payloads may require further shifting around to assess the CG or weight constraints, i.e., in the Appendix A example the SPACELAB was initially located 2 feet further toward the front. The AOA CG would have shifted forward (from station X_0 1080.4 shown) to station X_0 1076.0 which violates the station X_0 1076.7 constraint, resulting in moving the SPACE-LAB location aft (as shown).

4.2 EFFORT REQUIRED TO PERFORM ANALYSIS

The effort required to perform analyses depends on the detail required in assessing the proposed payload and flight requirements, and determining payload location and weight/CG. A typical analysis might require 1 to 2 days and two or three people.

Initial time to set up and run a mass properties calculation similar to the Appendix A example would be 1 day to determine initial vehicle and payload configuration, and 1 day to run the interactive program and document the results.

Computer time required would be approximately 1.5 seconds each time the calculation was repeated.

5. REFERENCES

1. Space Transportation System User Handbook, NASA/JSC.
2. Shuttle Operational Data Book, Rev A Volume I - Shuttle Systems Performance and Constraint Data, Volume II - Shuttle Mission Mass Properties Data, JSC-08934, September 1975.
3. Shuttle Systems Monthly Weight and Performance Status Report, JSC 09095-28, published monthly.

APPENDIX A
EXAMPLE OF
MASS PROPERTIES CALCULATION
FOR
SPACELAB 1 (LONG MODULE AND PALLET)

STS 100 FORM

REQUEST FOR FLIGHT ASSIGNMENT

DATE: 5/18/77

To: SPACE TRANSPORTATION SYSTEMS OPERATIONS
MAIL CODE MO
NATIONAL AERONAUTICS AND SPACE ADMINISTRATION
WASHINGTON D.C. 20546

FROM: _____

/S/

FLIGHT OBJECTIVES:
SPACELAB 1

___ Earnest money NASA approved
___ Commercial ESA approved
___ Other Government ___ DOD approved

Flight period Late CY 1980 or specific date _____ MISSION TYPE:
Inclination range 57° or specific inclination _____ Deployment
Altitude range 250 KM or specific altitude within 5 KM Attached
Payload configuration Long Module + Single Pallet Servicing
Flight duration, hours attached 165 Hr Discipline _____ Retrieval
Crew complement: Commander, pilot, mission specialist plus option for additional mission
specialist(s) 0 or payload specialist(s) 2

Payload Operations Control Center support:
___ GSFC ___ JPL JSC ___ Other ___ Not required

STDN and Tracking and Data Relay Satellite system support (comment):

Payload mass properties including flight kits: Specify flight kits used in weight:
(see JSC07700 vol. XIV):
Weight: Launch 32,000 lb. _____ kg
Landing 32,000 lb. _____ kg
Diameter: Launch _____ inches _____ mm
Landing _____ inches _____ mm
Length: Launch _____ inches _____ mm
Landing _____ inches _____ mm

Payload kWh estimate _____ kWh

Payload constraints and/or unique requirements:
No Additional OMS
No Planned EVA
No Power or Cooling During Ascent & Descent
Orientation, pointing, sunlight constraints, etc. (comment):

Special prelaunch and postlanding off-line support at launch and landing site (comment):

Special prelaunch and postlanding on-line support while in the Orbiter (comment):

Other comments:

Those organizations that will be non-U.S. Government users should also provide the following information:

- Do you request a dedicated flight? If so, do you intend to sublet services to other users?

- Do you request consideration in STS exceptional program selection process?

- Are you willing for your payload to fly on a space-available (standby) basis?

- Do you request to be flown under the definition of a "small self-contained package"?

- State desired date to begin contract negotiations.

- Does payload (or payloads) require revisit and/or retrieval services?

- List known optional services currently under consideration in order that flight requirements can be established

FLIGHT ASSIGNMENT

FLIGHT NO. _____ LAUNCH DATE _____
 OV- 102 NASA DOD COMM INTER
 CREW SIZE 5 MAN
 FLIGHT DURATION 7 DAY

- MAJOR FLIGHT KITS**
1. A/L TUNNEL ADAPTER
 2. PL BAY MOUNTED A/L
 3. ARS DUCT
 4. ATCS RADIATOR
 5. EPS KIT #4

DATE: 5/18/77 REV: _____

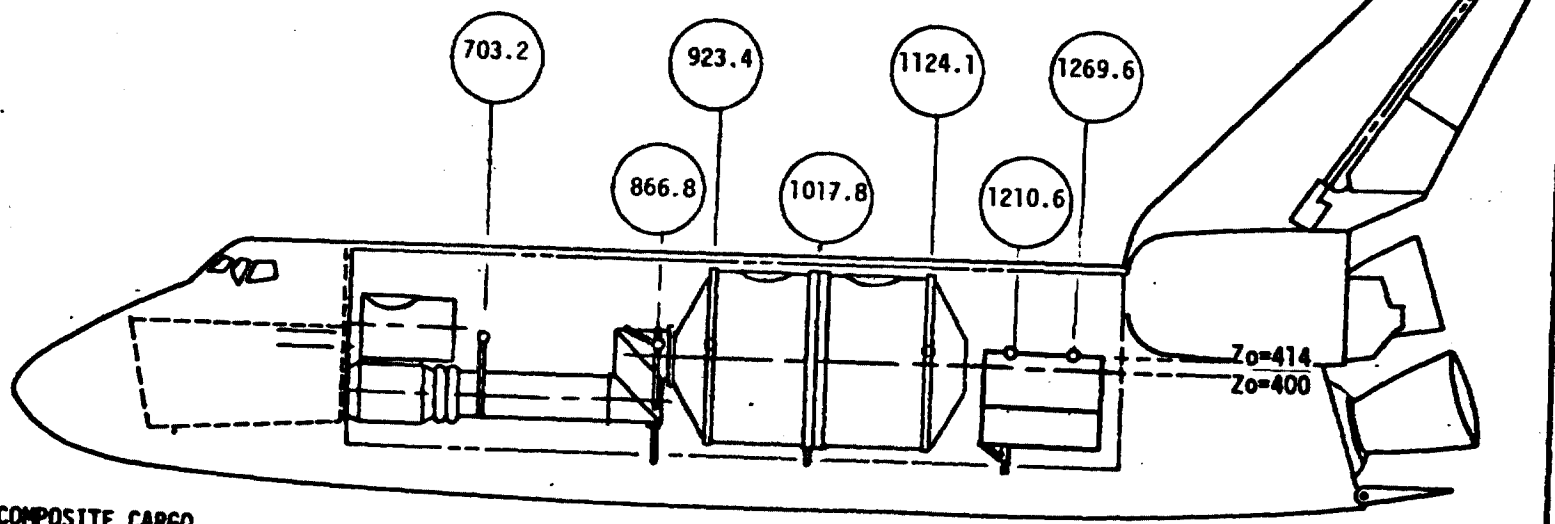

COMPOSITE CARGO
 WT (LB): UP 31,985
 WT (LB): DN 31,112

PL IDENT : SPACELAB 1, TUNNEL
 PL COMPOSITE:
 WT (LB): UP 24,653
 DN 23,780
 CG (IN): X_o 953.7
 Y_o -2.2 Z_o 385.6
 DIM (IN): L _____
 PL ORBIT: ALT (NM) _____ INC(°) _____
 STS ORBIT: ALT (NM) _____ INC(°) _____

PL IDENT : PALLET
 PL COMPOSITE:
 WT (LB): UP 7,332
 DN 7,332
 CG (IN): X_o 1238.6
 Y_o -2.8 Z_o 387.5
 DIM (IN): L _____
 PL ORBIT: ALT (NM) _____ INC(°) _____
 STS ORBIT: ALT (NM) _____ INC(°) _____

PL IDENT : _____
 PL COMPOSITE:
 WT (LB): UP _____
 DN _____
 CG (IN): X_o _____
 Y_o _____ Z_o _____
 DIM (IN): L _____
 PL ORBIT: ALT (NM) _____ INC(°) _____
 STS ORBIT: ALT (NM) _____ INC(°) _____

FLIGHT ASSIGNMENT WORKSHEET

FLIGHT NO. _____	LAUNCH DATE _____	DATE: 5/18/77	REV: _____
OV- 102	NASA <input checked="" type="checkbox"/> DOD <input type="checkbox"/> COMM <input type="checkbox"/> INTER <input type="checkbox"/>		

A-4

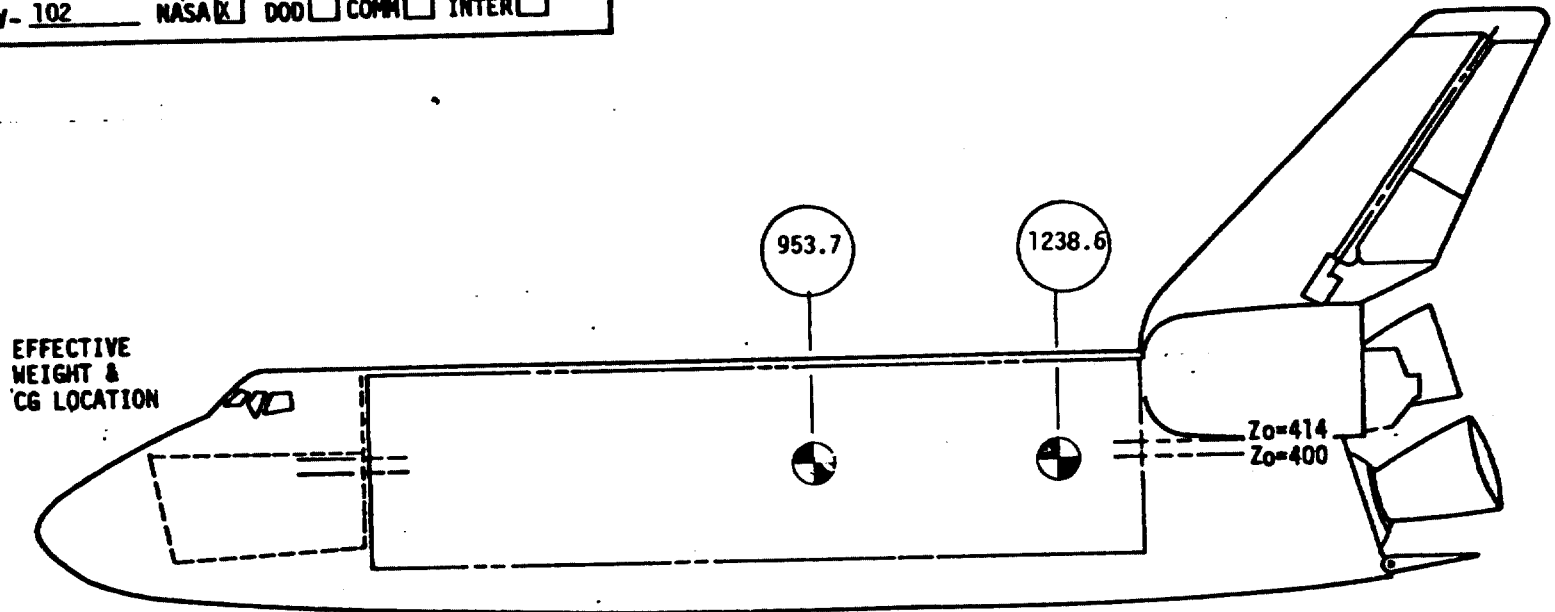

COMPOSITE VEHICLE

CARGO WT		BALLAST	NOMINAL ENTRY	RTLS	AOA
CG (IN)		WT (LB)	WT (LB): 202.417	WT (LB): 210.614	WT (LB): 207.113
WT(LB)	Xo Yo Zo	CG (IN)	CG (IN):	CG (IN):	CG (IN):
① UP 24653	953.7 -2.2 385.6	Xo _____	Xo= 1087.0	Xo= 1084.5	Xo= 1079.0
DN 23780	950.2 0 388.7	Yo _____	%= 65.8	%= 65.6	%= 65.2
② UP 7332	1238.6 -2.8 387.5	Zo _____	Yo= -0.1	Yo= 0.1	Yo= -0.2
DN 7332	1238.6 -2.8 387.5				
③ UP _____	_____				
DN _____	_____				

PAYLOAD CHARGEABLE WEIGHT SUMMARY

FLIGHT NO: _____		PL IDENTIFICATION: <u>SPACELAB Tunnel</u>		DATE: <u>5/18/77</u>	
LAUNCH DATE _____			REV: _____		
MISSION TYPE: DEPLOYMENT <input type="checkbox"/> ATTACHED <input checked="" type="checkbox"/> RETRIEVAL <input type="checkbox"/> SERVICING <input type="checkbox"/>					
CARRIER ATTACHMENT		PRIMARY LOCATION		KEEL LOCATION	
STABILIZING LOCATION					
Xo (IN)	<u>703.2</u>	Xo (IN)	<u>866.8</u>	Xo (IN)	<u>866.8</u>
BL NO.	<u>(1)</u>	BL NO.	<u>(1)</u>	KB NO.	<u>(1)</u>
BR NO.	_____	BR NO.	_____	ACTIVE	_____
DF	_____	DF	_____	PASSIVE	_____
NDF	_____	NDF	_____		_____
PAYLOAD CHARGEABLE (1) bridges & fittings are specially made ref telcon Crumley, MSFC.					
ATTACHMENT					
STABILIZING		WT (LB)		CG (IN) (STS COORD)	
<u>16 (1) +</u>	<u>16</u>	=	<u>32</u>	Xo <u>703.2</u>	Yo <u>0</u> Zo <u>414</u>
PRIMARY					
<u>16 (1) +</u>	<u>16</u>	=	<u>32</u>	Xo <u>866.8</u>	Yo <u>0</u> Zo <u>414</u>
	<u>KEEL</u>	=	<u>16</u>	Xo <u>866.8</u>	Yo <u>0</u> Zo <u>305</u>
LONG FITTING					
<u>2</u>	x <u>10.5 (1)</u>	=	<u>21</u>	Xo <u>703.2</u>	Yo <u>0</u> Zo <u>414</u>
<u>2</u>	x <u>10.5</u>	=	<u>21</u>	Xo <u>866.8</u>	Yo <u>0</u> Zo <u>414</u>
COMPOSITE UP & DN		=	<u>122</u>	Xo <u>795.7</u>	Yo <u>0</u> Zo <u>399.7</u>
ITEM WT (LB) CG (IN) (STS COORD)					
CARRIER (2)	_____	Xo _____	Yo _____	Zo _____	
ASE (2)	_____	Xo _____	Yo _____	Zo _____	
PAYLOAD (2)	_____	Xo _____	Yo _____	Zo _____	
COMPOSITE (2) see Spacelab, weights added to Spacelab Payload					
UP	_____	Xo _____	Yo _____	Zo _____	
DOWN	_____	Xo _____	Yo _____	Zo _____	
TOTAL					
UP	<u>122</u>	Xo <u>795.7</u>	Yo <u>0</u>	Zo <u>399.7</u>	
DOWN	<u>122</u>	Xo <u>795.7</u>	Yo <u>0</u>	Zo <u>399.7</u>	

PAYLOAD CHARGEABLE WEIGHT SUMMARY

FLIGHT NO: _____		PL IDENTIFICATION: <u>SPACELAB (Long)</u>		DATE: <u>5/18/77</u>	
LAUNCH DATE _____			REV: _____		
MISSION TYPE: DEPLOYMENT <input type="checkbox"/> ATTACHED <input checked="" type="checkbox"/> RETRIEVAL <input type="checkbox"/> SERVICING <input type="checkbox"/>					
CARRIER ATTACHMENT		PRIMARY LOCATION		KEEL LOCATION	
STABILIZING LOCATION					
Xo (IN)	<u>923.5</u>	Xo (IN)	<u>1124.1</u>	Xo (IN)	<u>1017.8</u>
BL NO.	<u>None</u>	BL NO.	<u>10</u>	KB NO.	<u>8</u>
BR NO.	<u>7</u>	BR NO.	<u>10</u>	ACTIVE	_____
DF	_____	DF	_____	PASSIVE	_____
NDF	_____	NDF	_____		_____
PAYLOAD CHARGEABLE					
ATTACHMENT					
STABILIZING		WT (LB)		CG (IN) (STS COORD)	
<u>0</u>	<u>+ 163</u>	=	<u>163</u>	Xo <u>949.3</u>	Yo <u>94</u> Zo <u>414</u>
PRIMARY					
<u>145</u>	<u>+ 145</u>	=	<u>290</u>	Xo <u>1115.5</u>	Yo <u>0</u> Zo <u>414</u>
	KEEL	=	<u>182</u>	Xo <u>1017.8</u>	Yo <u>0</u> Zo <u>305</u>
LONG FITTING					
<u>1</u>	<u>x 51</u>	=	<u>51</u>	Xo <u>923.5</u>	Yo <u>94</u> Zo <u>414</u>
<u>2</u>	<u>x 51</u>	=	<u>102</u>	Xo <u>1124.1</u>	Yo <u>0</u> Zo <u>414</u>
COMPOSITE UP & DN		=	<u>788</u>	Xo <u>1047.5</u>	Yo <u>19.4</u> Zo <u>388.8</u>
ITEM		WT (LB)		CG (IN) (STS COORD)	
CARRIER	_____	Xo	_____	Yo	_____ Zo _____
ASE	_____	Xo	_____	Yo	_____ Zo _____
PAYLOAD	<u>19,743</u>	Xo	<u>988.8</u>	Yo	<u>-1.9</u> Zo <u>394.2</u>
COMPOSITE					
UP	<u>19,743</u>	Xo	<u>988.8</u>	Yo	<u>-1.9</u> Zo <u>394.2</u>
DOWN	<u>19,743</u>	Xo	<u>988.8</u>	Yo	<u>-1.9</u> Zo <u>394.2</u>
TOTAL					
	UP	<u>20,531</u>	Xo <u>991.</u>	Yo <u>-1.1</u>	Zo <u>394.</u>
	DOWN	<u>20,531</u>	Xo <u>991.</u>	Yo <u>-1.1</u>	Zo <u>394.</u>

PAYLOAD CHARGEABLE WEIGHT SUMMARY

FLIGHT NO: _____ PL IDENTIFICATION: Pallet DATE: 5/18/77
 LAUNCH DATE _____ REV: _____
 MISSION TYPE: DEPLOYMENT ATTACHED RETRIEVAL SERVICING

CARRIER ATTACHMENT STABILIZING LOCATION	PRIMARY LOCATION	KEEL LOCATION
Xo (IN) <u>1210.6</u>	Xo (IN) <u>1269.6</u>	Xo (IN) <u>1210.6</u>
BL NO. <u>12</u>	BL NO. <u>13</u>	KB NO. <u>12</u>
BR NO. <u>12</u>	BR NO. <u>13</u>	ACTIVE _____
DF _____	DF _____	PASSIVE _____
NDF _____	NDF _____	

PAYLOAD CHARGEABLE

ATTACHMENT

STABILIZING	WT (LB)	Xo	CG (IN) (STS COORD)	Yo	Zo
<u>195 + 195 =</u>	<u>390</u>	Xo	<u>1278.</u>	Yo <u>0</u>	Zo <u>414</u>
PRIMARY					
<u>169 + 169 =</u>	<u>338</u>	Xo	<u>1220.</u>	Yo <u>0</u>	Zo <u>414</u>
KEEL =	<u>270</u>	Xo	<u>1210.6</u>	Yo <u>0</u>	Zo <u>305</u>
LONG FITTING					
<u>2 x 51 =</u>	<u>102</u>	Xo	<u>1210.6</u>	Yo <u>0</u>	Zo <u>414</u>
<u>2 x 51 =</u>	<u>102</u>	Xo	<u>1269.6</u>	Yo <u>0</u>	Zo <u>414</u>
COMPOSITE UP & DN =	<u>1202</u>	Xo	<u>1240.1</u>	Yo <u>0</u>	Zo <u>389.5</u>

ITEM	WT (LB)	Xo	CG (IN) (STS COORD)	Yo	Zo
CARRIER		Xo		Yo	Zo
ASE	<u>1457.7</u>	Xo	<u>1237.54</u>	Yo <u>1.71</u>	Zo <u>363.93</u>
PAYLOAD	<u>4671.95</u>	Xo	<u>1238.52</u>	Yo <u>-4.97</u>	Zo <u>394.41</u>
COMPOSITE					
UP	<u>6130</u>	Xo	<u>1238.3</u>	Yo <u>-3.4</u>	Zo <u>387.2</u>
DOWN	<u>6130</u>	Xo	<u>1238.3</u>	Yo <u>-3.4</u>	Zo <u>387.2</u>
TOTAL					
UP	<u>7332</u>	Xo	<u>1238.6</u>	Yo <u>-2.8</u>	Zo <u>387.5</u>
DOWN	<u>7332</u>	Xo	<u>1238.6</u>	Yo <u>-2.8</u>	Zo <u>387.5</u>

PAYLOAD CHARGEABLE WEIGHT SUMMARY

FLIGHT NO. _____		PL IDENTIFICATION: <u>SPACELAB</u>		DATE: <u>5/18/77</u>	
LAUNCH DATE _____		REV: _____			
<u>FLIGHT KITS</u>		<u>WT (LB)</u>	<u>CG DND (STS COORD)</u>		
DOCKING MODULE (UP & DND)			Xo	Yo	Zo
A/L TUNNEL ADAPTER (UP & DND)	900		Xo	Yo	Zo 357.9
P/L BAY MOUNTED A/L (UP & DND)	912 (1)		Xo	Yo	Zo 371.5
ARS DUCT (UP & DND)	21		Xo	Yo	Zo 357.9
ATCS RADIATOR WET	173		Xo	Yo 61	Zo 473.
DRY	141		Xo	Yo 150	Zo 366.
RMS # 2			Xo	Yo	Zo
PC & WW TANKS			Xo	Yo	Zo
UP			Xo	Yo	Zo
DOWN			Xo	Yo	Zo
KU-BAND COMM			Xo	Yo	Zo
MSS PCM RECORDER			Xo	Yo	Zo
EPS KIT #1			Xo	Yo	Zo
WET			Xo	Yo	Zo
DRY			Xo	Yo	Zo
KIT #2			Xo	Yo	Zo
WET			Xo	Yo	Zo
DRY			Xo	Yo	Zo
KIT #3			Xo	Yo	Zo
WET			Xo	Yo	Zo
DRY			Xo	Yo	Zo
KIT #4			Xo	Yo	Zo
WET	1643	1000.	Xo	Yo -39	Zo 299.
DRY	770	942	Xo	Yo -10.	Zo 299.
KIT #5			Xo	Yo	Zo
WET			Xo	Yo	Zo
DRY			Xo	Yo	Zo
KIT #6			Xo	Yo	Zo
WET			Xo	Yo	Zo
DRY			Xo	Yo	Zo
KIT #7			Xo	Yo	Zo
WET			Xo	Yo	Zo
DRY			Xo	Yo	Zo
EPS TAN K			Xo	Yo	Zo
SETS IN BAY			Xo	Yo	Zo
DRY			Xo	Yo	Zo
DMS KIT 500' ΔV			Xo	Yo	Zo
WET			Xo	Yo	Zo
DRY			Xo	Yo	Zo
1000' ΔV			Xo	Yo	Zo
WET			Xo	Yo	Zo
DRY			Xo	Yo	Zo
1500' ΔV			Xo	Yo	Zo
WET			Xo	Yo	Zo
DRY			Xo	Yo	Zo
CONTROL & DISPLAY			Xo	Yo	Zo
CABLING	112	609	Xo	Yo 0	Zo 371.5
EXTENDED MISSION			Xo	Yo	Zo
<u>CREW EQUIPMENT (ABOVE 3 MAN DAYS)</u>					
5th Seat					
FIXED WT (LB) (PER MAN)	54.	494		48	340.
370.7 x 2 =	741.4	497.2	Xo	24.4	Zo 364.6
TIME DEPENDANT (PER MAN, PER DAY)					
13.7 x 2 x 7 =	191.8	504.3	Xo	0.9	Zo 380.2
3 x 4 =	164.4				
TOTAL (2)	UP 4,000.6	767.	Xo	-8.1	Zo 342.1
	DOWN 3,127.6	687.7	Xo	7.6	Zo 354.1

(1) Not charged to Payload wt (already in inert veh. wt)
 (2) Assumes EPS Kit #4 dry wt

SEP-19-75

INSERT PRELAUNCH VEH. WT
C.G. (WITH MOMENTS OF
INERTIA = 0)

0.0.0.0
207251.1120.5.5.384.3
0.0.0.0.0.0

REPRODUCIBILITY OF THE
ORIGINAL PAGE IS POOR

LESS Δ FOR FITTINGS & SHIFTING
AIRLOCK

MASS (LB)	CG (INCHES)			IXX	INERTIA (SLUG-FT ² × 10 ⁰⁰⁰)			
	X	Y	Z		IYY	IZZ	PXY	PYZ
PVZ BASE VEHICLE: 207251.1120.5.5.384.3 .00000	1120.5	.5	384.3	.0000	.0000	.0000	.00000	.0000
>-450.1120.5.0.384.3 >0.0.0.0.0.0 ADD PAYLOAD: -450.1120.5.0.384.3 .00000	1120.5	.0	384.3	.0000	.0000	.0000	.00000	.0000
COMPOSITE VEHICLE: 202751.1120.5.5.384.3 .00000	1120.5	.5	384.3	-.0000	-.0000	-.0000	-.00000	.0000

ADD PAYLOAD

>31935.1019.-2.3.336 >0.0.0.0.0.0 ADD PAYLOAD: 31935.1019.0.-2.3.336.0 .00000	1019.0	-2.3	336.0	.0000	.0000	.0000	.00000	.0000
COMPOSITE VEHICLE: 233786.1122.5.1.385.0 -.00002	1122.5	.1	385.0	.0001	.0354	.0355	.00200	-.0002

LESS RTLS Δ

>-23172.1407.7.475.8 >0.0.0.0.0.0 ADD PAYLOAD: -23172.1407.0.7.475.8 .00000	1407.0	.7	475.8	.0000	.0000	.0000	.00000	.0000
---	--------	----	-------	-------	-------	-------	--------	-------

RTLS

COMPOSITE VEHICLE: 210614.1094.5.0.372.8 -.00033	1094.5	.0	372.8	-.0568	-.5294	-.4724	.00033	-.173
--	--------	----	-------	--------	--------	--------	--------	-------

LESS AOA Δ

>-3501.1409.4.13.7.434.3 >0.0.0.0.0.0 ADD PAYLOAD: -3501.1409.4.13.7.434.3 .00000	1409.4	13.7	434.3	.0000	.0000	.0000	.00000	.0000
---	--------	------	-------	-------	-------	-------	--------	-------

AOA

COMPOSITE VEHICLE: 207113.1079.0.-2.3.371.8 -.00102	1079.0	-2.3	371.8	-.0599	-.6134	-.5537	-.00253	-.194
---	--------	------	-------	--------	--------	--------	---------	-------

INITIALIZE PROGRAM @ 0

INSERT PAYLOAD WT & CG

>
31935.
0.0.0.0
>31935.1019.-2.3.336
>0.0.0.0.0.0

ADD CV @ EI

MASS (LB)	CG (INCHES)			IXX	INERTIA (SLUG-FT ² × 10 ⁰⁰⁰)			
	X	Y	Z		IYY	IZZ	PXY	PYZ
PVZ BASE VEHICLE: 31935.1019.0.-2.3.336.0 .00000	1019.0	-2.3	336.0	.0000	.0000	.0000	.00000	.0000
>170932.1099.8.3.372.2 >0.0.0.0.0.0 ADD PAYLOAD: 170932.1099.8.3.372.2 .00000	1099.8	.3	372.2	.0000	.0000	.0000	.00000	.0000
COMPOSITE VEHICLE: 202867.1087.1.-1.374.4 -.00021	1087.1	-1.1	374.4	.0011	.0291	.0329	.00122	-.0025

LESS Δ FOR FITTINGS &
SHIFTING AIRLOCK

>-450.1120.5.0.384.3 >0.0.0.0.0.0 ADD PAYLOAD: -450.1120.5.0.384.3 .00000	1120.5	.0	384.3	.0000	.0000	.0000	.00000	.0000
---	--------	----	-------	-------	-------	-------	--------	-------

EI

COMPOSITE VEHICLE: 202417.1087.0.-1.374.3 -.00021	1087.0	-1.1	374.3	.0011	.0289	.0329	.00122	-.0025
---	--------	------	-------	-------	-------	-------	--------	--------

>END TIC
>EXECUTION TERMINATED
>FIN

RUNID: 3001 ACCT: 31048-0196-0 PROJECT: 507-728485
TIME: TOTAL: 00100101.017 CHARGE: 00100102.035
CARD: 00100100.258 I/O: 00100100.543
C/ER: 00100100.206 UNIT: 00121122.104
JOB: 00100100.206 ET: 300501
START: 15:14:19 JUN 01-1977 TIME: 15:47:24 JUN 01-1977
ACCTNAME: TIME: 00

APPENDIX B

EXAMPLE OF

MASS PROPERTIES CALCULATION

FOR

MULTIPLE CARGO

(TDRS/2-STAGE IUS

AND SBS/SSUS D)

To: SPACE TRANSPORTATION SYSTEMS OPERATIONS
 MAIL CODE MO
 NATIONAL AERONAUTICS AND SPACE ADMINISTRATION
 WASHINGTON D.C. 20546

FROM: _____

 /S/

FLIGHT OBJECTIVES:

Place Communications Satellite in Geostationary Orbit

___ Earnest money ___ NASA approved
 ___ Commercial ___ ESA approved
 ___ Other Government ___ DOD approved

Flight period a. May 1980, b. June 1980 c. July 1980 or specific date MISSION TYPE:
 Inclination range _____ or specific inclination 26.6° ± 0.24° Deployment
 Altitude range 150 ± 3nm perigee or specific altitude 193.2 ± 48.0 nm apogee Attached
 Payload configuration TDRSS/IUS/ASE Servicing
 Flight duration, hours attached Minimum Discipline see constraints below Retrieval
 Crew complement: Commander, pilot, mission specialist plus option for additional mission specialist(s) 0 or payload specialist(s) 0
 Payload Operations Control Center support:
 GSFC JPL JSC Other Not required

STDN and Tracking and Data Relay Satellite system support (comment):

Payload mass properties including flight kits: Specify flight kits used in weight: (see JSC07700 vol. XIV):
 Weight: Launch 39920 lb. _____ kg
 Landing 3777 lb. _____ kg
 Diameter: Launch 115 inches _____ mm
 Landing 115 inches _____ mm
 Length: Launch 437.9 inches _____ mm
 Landing 148.8 inches _____ mm

Payload kWh estimate _____ kWh

Payload constraints and/or unique requirements: Geostationary final orbit.
Liquid apogee engine

Orientation, pointing, sunlight constraints, etc. (comment):

Parking Orbit, Doors Open Parking Orbit, Doors Closed
<1.2 hrs. max. direct sunlight 2 hrs. max.
<4.0 hrs. max. no sun

Special prelaunch and postlanding off-line support at launch and landing site (comment):

100,000 class clean room environment

Special prelaunch and postlanding on-line support while in the Orbiter (comment):

65° FAIR on pad; GN₂ prelaunch (T-2 hrs.) purge acceptable

Other comments:

Those organizations that will be non-U.S. Government users should also provide the following information:

- Do you request a dedicated flight? If so, do you intend to sublet services to other users?

- Do you request consideration in STS exceptional program selection process?

- Are you willing for your payload to fly on a space-available (standby) basis?

- Do you request to be flown under the definition of a "small self-contained package"?

- State desired date to begin contract negotiations.

- Does payload (or payloads) require revisit and/or retrieval services?

- List known optional services currently under consideration in order that flight requirements can be established.

STS 100 FORM

REQUEST FOR FLIGHT ASSIGNMENT

DATE: 5/23/77

To: SPACE TRANSPORTATION SYSTEMS OPERATIONS
MAIL CODE MO
NATIONAL AERONAUTICS AND SPACE ADMINISTRATION
WASHINGTON D.C. 20546

FROM: _____

/S/

FLIGHT OBJECTIVES:
Deploy SBS Communications Satellite to
Geostationary Orbit

Earnest money NASA approved
 Commercial ESA approved
 Other Government DOD approved

a. June/July 1980 b. Oct/Nov 1980 c. Backup 2nd Quarter FY 1981
Flight period _____ or specific date _____ MISSION TYPE:
Inclination range 28.5 or specific inclination _____ Deployment
Altitude range 160 NMI or specific altitude _____ Attached
Payload configuration Delta 3910 PAM Class Servicing
Flight duration, hours attached _____ Discipline _____ Retrieval
Crew complement: Commander, pilot, mission specialist plus option for additional mission
specialist(s) _____ or payload specialist(s) _____
Payload Operations Control Center support:
 GSFC JPL JSC Other Not required _____

STDN and Tracking and Data Relay Satellite system support (comment):

Payload mass properties including flight kits: Specify flight kits used in weight:
(see JSC07700 vol. XIV):
Weight: Launch 8340 lb. _____ kg
 Landing 2250 lb. _____ kg
Diameter: Launch 86 inches _____ mm
 Landing _____ inches _____ mm
Length: Launch 92 inches _____ mm
 Landing _____ inches _____ mm
Payload kWh estimate .75 kWh

Payload constraints and/or unique requirements:

Orientation, pointing, sunlight constraints, etc. (comment):

Minimum Sunlight
Near Room Temperature

Special prelaunch and postlanding off-line support at launch and landing site (comment):

Special prelaunch and postlanding on-line support while in the Orbiter (comment):

(OVER)

Other comments:

Those organizations that will be non-U.S. Government users should also provide the following information:

- Do you request a dedicated flight? If so, do you intend to sublet services to other users?

- Do you request consideration in STS exceptional program selection process?

- Are you willing for your payload to fly on a space-available (standby) basis?

- Do you request to be flown under the definition of a "small self-contained package"?

- State desired date to begin contract negotiations.

- Does payload (or payloads) require revisit and/or retrieval services?

- List known optional services currently under consideration in order that flight requirements can be established.

FLIGHT ASSIGNMENT

FLIGHT NO. _____ LAUNCH DATE _____ OV- <u>102</u> NASA <input checked="" type="checkbox"/> DOD <input type="checkbox"/> COMM <input type="checkbox"/> INTER <input type="checkbox"/> CREW SIZE <u>3</u> FLIGHT DURATION <u>1 DAY</u>	MAJOR FLIGHT KITS	DATE: <u>5-23-77</u>	REV: _____
---	-------------------	----------------------	------------

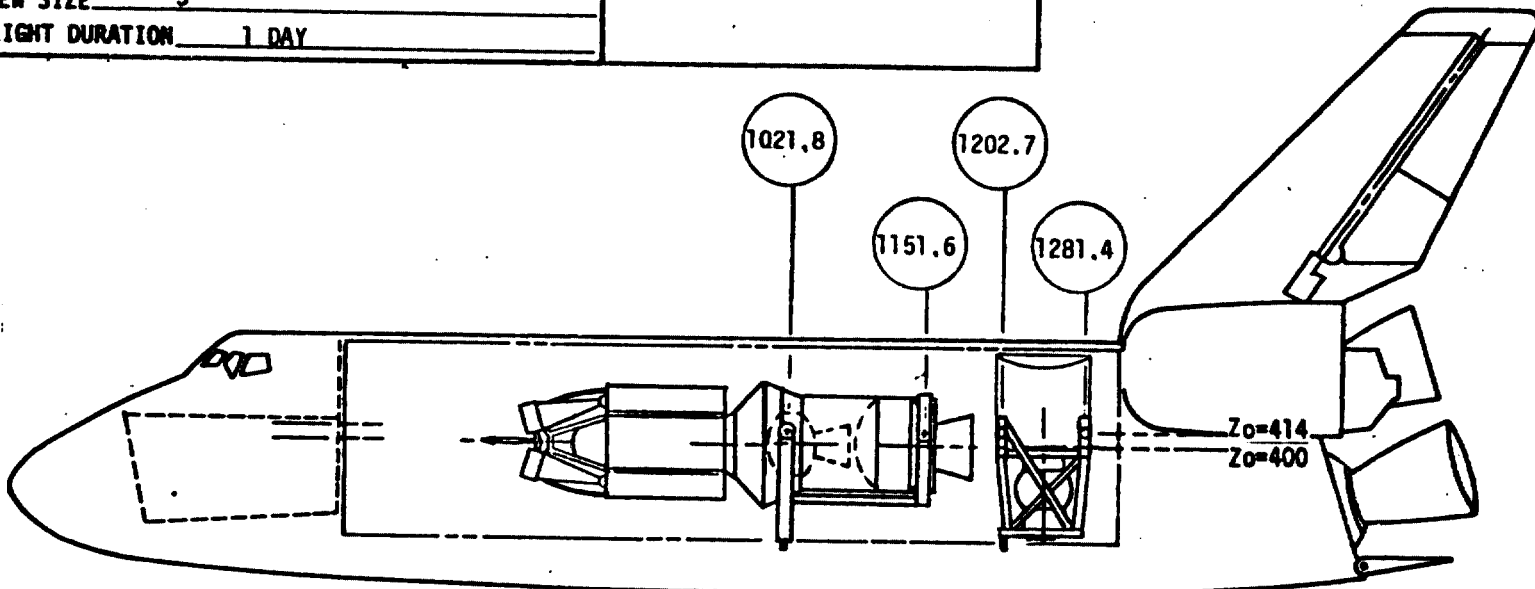

COMPOSITE CARGO
 WT (LB): UP 50.530
 WT (LB): DN 8.199

PL IDENT : <u>TORS (IUS 2-STAGE)</u> PL COMPOSITE: WT (LB): UP <u>40890</u> DN <u>4747</u> CG (IN): X _o <u>1073.5</u> (1044.9) Yo <u>0</u> Z _o <u>399.8</u> (398.7)	PL IDENT : <u>SBS (SSUS D)</u> PL COMPOSITE: WT (LB): UP <u>9640</u> DN <u>3452</u> CG (IN): X _o <u>12421</u> (1242.2) Yo <u>0</u> Z _o <u>431.4</u> (396.3)	PL IDENT : _____ PL COMPOSITE: WT (LB): UP _____ DN _____ CG (IN): X _o _____ Yo _____ Z _o _____
#IM (IN): L _____ PL ORBIT: ALT (NM) _____ INC(°) _____ STS ORBIT: ALT (NM) _____ INC(°) _____	DIM (IN): L _____ PL ORBIT: ALT (NM) _____ INC(°) _____ STS ORBIT: ALT (NM) _____ INC(°) _____	DIM (IN): L _____ PL ORBIT: ALT (NM) _____ INC(°) _____ STS ORBIT: ALT (NM) _____ INC(°) _____

B-4

FLIGHT ASSIGNMENT WORKSHEET

DATE:

5-23-77

REV:

FLIGHT NO. _____ LAUNCH DATE _____
 OV- 102 NASA DOD COMM INTER

EFFECTIVE WEIGHT & CG LOCATION

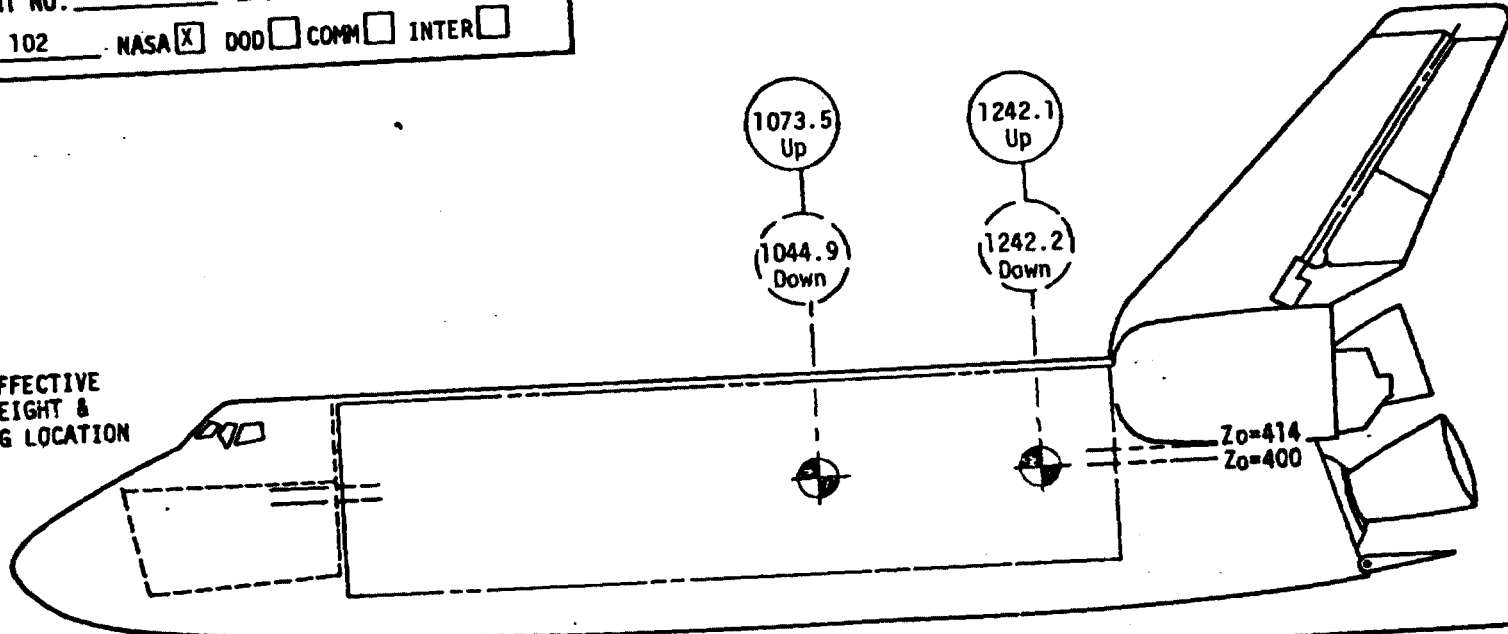

B-5

COMPOSITE VEHICLE

CARGO WT				BALLAST	NOMINAL ENTRY	RTLS	AOA
CG (IN)				WT (LB)	WT (LB): 179.081	WT (LB): 229.609	WT (LB): 226.108
WT(LB)	Xo	Yo	Zo	CG (IN)	CG (IN):	CG (IN): 1098.3	CG (IN): 1093.5
① UP 40890	1073.5	0	399.8	Xo _____	Xo= 1101.1	Xo= _____	Xo= _____
DN 4747	1044.9	0	398.7	Yo _____	%= 66.9	%= 66.7	%= 66.3
② UP 9640	1242.1	0	431.4	Zo _____	Yo= 0.3	Yo= 0.1	Yo= 0.2
DN 3452	1242.2	0	396.3				
③ UP _____	_____	_____	_____				
DN _____	_____	_____	_____				

PAYLOAD CHARGEABLE WEIGHT SUMMARY

FLIGHT NO: _____ PL IDENTIFICATION: TDRS A/IUS 2-STAGE DATE: 5/23/77

LAUNCH DATE _____ REV: _____

MISSION TYPE: DEPLOYMENT ATTACHED RETRIEVAL SERVICING

CARRIER ATTACHMENT STABILIZING LOCATION

PRIMARY LOCATION

KEEL LOCATION

Xo (IN)	1021.8	Xo (IN)	1151.6	Xo (IN)	1021.8
BL NO.	8	BL NO.	11	KB NO.	8
BR NO.	8	BR NO.	11	ACTIVE	
DF		DF		PASSIVE	
NDF		NDF			

PAYLOAD CHARGEABLE

ATTACHMENT

STABILIZING

WT (LB)

CG (IN) (STS COORD)

147 + 147 = 294 Xo 1009.8 Yo 0 Zo 414

PRIMARY

145 + 145 = 290 Xo 1165.9 Yo 0 Zo 414

KEEL = 182 Xo 1109.8 Yo 0 Zo 305

LONG FITTING

2 x 51 = 102 Xo 1021.8 Yo 0 Zo 414

2 x 51 = 102 Xo 1151.6 Yo 0 Zo 414

COMPOSITE UP & DN = 970 Xo 1072.6 Yo 0 Zo 393.5

ITEM

WT (LB)

CG (IN) (STS COORD)

CARRIER 32,643 Xo 1093.7 Yo 0 Zo 400

ASE 3,777 Xo 1037.8 Yo 0 Zo 400

PAYLOAD 3,500 Xo 924.1 Yo 0 Zo 400

COMPOSITE

UP 39,920 Xo 1073.5 Yo 0 Zo 400

DOWN 3,777 Xo 1037.8 Yo 0 Zo 400

TOTAL UP 40,890 Xo 1073.5 Yo 0 Zo 399.8

DOWN 4747 Xo 1044.9 Yo 0 Zo 398.7

PAYLOAD CHARGEABLE WEIGHT SUMMARY

FLIGHT NO: _____ PL IDENTIFICATION: SBS A/SSUS-D DATE: 5/23/77

LAUNCH DATE _____ REV: _____

MISSION TYPE: DEPLOYMENT ATTACHED RETRIEVAL SERVICING

**CARRIER ATTACHMENT
STABILIZING LOCATION**

PRIMARY LOCATION

KEEL LOCATION

Xo (IN) <u>1202.7</u>	Xo (IN) <u>1281.4</u>	Xo (IN) <u>1202.7</u>
BL NO. <u>12</u>	BL NO. <u>13</u>	KB NO. <u>12</u>
BR NO. <u>12</u>	BR NO. <u>13</u>	ACTIVE _____
DF _____	DF _____	PASSIVE _____
NDF _____	NDF _____	

PAYLOAD CHARGEABLE

ATTACHMENT

STABILIZING

WT (LB)

CG (IN) (STS COORD)

169 + 169 = 338 Xo 1220 Yo 0 Zo 414

PRIMARY

195 + 195 = 390 Xo 1278 Yo 0 Zo 414

KEEL = 270 Xo 1220 Yo 0 Zo 305

LONG FITTING

2 x 51 = 102 Xo 1202.7 Yo 0 Zo 414

2 x 51 = 102 Xo 1281.4 Yo 0 Zo 414

COMPOSITE UP & DN = 1202 Xo 1242.6 Yo 0 Zo 389.5

ITEM

WT (LB)

CG (IN) (STS COORD)

CARRIER 3868 Xo 1242.05 Yo 0 Zo 451

ASE 2250 Xo 1242.05 Yo 0 Zo 400

PAYLOAD 2320 Xo 1242.05 Yo 0 Zo 451

COMPOSITE

UP 8438 Xo 1242.05 Yo 0 Zo 437.4

DOWN 2250 Xo 1242.05 Yo 0 Zo 400

TOTAL UP 9640 Xo 1242.1 Yo 0 Zo 431.4

DOWN 3452 Xo 1242.2 Yo 0 Zo 396.3

UNIVAC 1100 OPERATING SYSTEM VER. 31.244.2120 (R01)
 *SRUN GDLMI-2004P-0196-C-FMT-L70495
 DATE: 052577 TIME: 092002
 *DUCE D.-DOWNG.
 READY
 >0:0T D.MF
 >4747.1044.2+0.398.7
 >0+0+0+0+0+0.

EXECUTE MP PROGRAM TORS/IUS
 DOWN WEIGHT & CG
 TORS/IUS DOWN WEIGHT & CG

MASS(LB)	CG(INCHES)			IXX	INERTIA (SLUG-FT ² *10 ⁺⁺⁶)			
	X	Y	Z		IYY	IZZ	PHY	PXZ
BASE VEHICLE:								
4747.	1044.2	.0	398.7	.0000	.0000	.0000	.00000	.0000
.00000								

SBS/SSUS-D DOWN WEIGHT & CG

>3452.1242.1+0.396.3
 >0+0+0+0+0+0
 ADD PAYLOAD:
 3452. 1242.1 .0 396.3 .0000 .0000 .0000 .00000 .0000
 .00000

COMBINED CARGO DOWN

COMPOSITE VEHICLE:
 8199. 1127.9 .0 397.7 .0000 .0168 .0168 .00000 -.0002
 .00000

ORBITER AT EI

>17002.1099.8+.3+372.2
 >0+0+0+0+0+0
 ADD PAYLOAD:
 17002. 1099.8 .3 372.2 .0000 .0000 .0000 .00000 .0000
 .00000

EI

COMPOSITE VEHICLE:
 17901. 1101.1 .3 373.4 .0011 .0192 .0181 -.00001 .0010
 -.00001

REINITIALIZE PROGRAM AT 0

>.0.
 >0+0+0+0+0+0
 >40870.1073.5+0.399.8
 >0+0+0+0+0+0

TORS/IUS UP WEIGHT & CG

MASS(LB)	CG(INCHES)			IXX	INERTIA (SLUG-FT ² *10 ⁺⁺⁶)			
	X	Y	Z		IYY	IZZ	PHY	PXZ
BASE VEHICLE:								
40870.	1073.5	.0	399.8	.0000	.0000	.0000	.00000	.0000
.00000								

SBS/SSUS-D UP WEIGHT & CG

>9640.1242.1+0.431.4
 >0+0+0+0+0+0
 ADD PAYLOAD:
 9640. 1242.1 .0 431.4 .0000 .0000 .0000 .00000 .0000
 .00000

COMBINED CARGO UP

COMPOSITE VEHICLE:
 50510. 1105.7 .0 405.8 .0017 .0495 .0479 .00000 .0050
 .00000

ORBITER PRELAUNCH

>207251.1138.5+.5+384.3
 >0+0+0+0+0+0
 ADD PAYLOAD:
 207251. 1138.5 .5 384.3 .0000 .0000 .0000 .00000 .0000
 .00000

COMPOSITE VEHICLE:
 257781. 1132.1 .4 388.9 .0056 .0629 .0573 .00014 .0029
 -.00009

LESS RTLS Δ

>-20172.1407.7+.4+.5.9
 >0+0+0+0+0+0
 ADD PAYLOAD:
 -20172. 1407.0 .7 475.9 .0000 .0000 .0000 .00000 .0000
 .00000

RTLS

COMPOSITE VEHICLE:
 226609. 1099.3 .4 379.3 -.0461 -.5648 -.4507 -.00042 -.1602
 -.00027

LESS AOA Δ

>-3501.1402.4+13.7+.434.3
 >0+0+0+0+0+0
 ADD PAYLOAD:
 -3501. 1402.4 13.7 434.3 .0000 .0000 .0000 .00000 .0000
 .00000

AOA

COMPOSITE VEHICLE:
 223108. 1099.3 .2 377.4 -.0406 -.5815 -.4531 -.00020 -.1707
 -.00004