

## **General Disclaimer**

### **One or more of the Following Statements may affect this Document**

- This document has been reproduced from the best copy furnished by the organizational source. It is being released in the interest of making available as much information as possible.
- This document may contain data, which exceeds the sheet parameters. It was furnished in this condition by the organizational source and is the best copy available.
- This document may contain tone-on-tone or color graphs, charts and/or pictures, which have been reproduced in black and white.
- This document is paginated as submitted by the original source.
- Portions of this document are not fully legible due to the historical nature of some of the material. However, it is the best reproduction available from the original submission.

**NASA Technical Memorandum 78634**

AIRCRAFT ENERGY EFFICIENCY  
LAMINAR FLOW CONTROL WING  
DESIGN STUDY

(NASA-TM-78634) AIRCRAFT ENERGY EFFICIENCY  
LAMINAR FLOW CONTROL WING DESIGN STUDY  
(NASA) 34 p HC A03/MF A01 CSCL 01C

N78-13042

Unclas  
55215  
G3/05

Tom F. Bonner, Jr., Joseph D. Pride, Jr. and  
William W. Fernald

OCTOBER 1977



**NASA**  
National Aeronautics and  
Space Administration  
**Langley Research Center**  
Hampton, Virginia 23665

AIRCRAFT ENERGY EFFICIENCY  
LAMINAR FLOW CONTROL WING  
DESIGN STUDY

by

Tom F. Bonner, Jr.  
Joseph D. Pride, Jr.  
and  
William W. Fernald

SUMMARY

An engineering design study was made of a commercial-passenger-type long range aircraft with laminar flow control (LFC) applied to its wings. The objective of this engineering design study was to perform the necessary design and analyses to configure an integrated LFC wing, including all of the subsystem interfaces associated with a typical wing design plus those special requirements related to the LFC systems.

The LFC-aircraft configuration selected for this design study was sized for a range of 10,192.5 km (5500 n. mi.) with 200 tourist class passengers in 7 abreast seating, plus 4,535.9 kg (10,000 lbm.) cargo and a F.A.R. take-off field length not to exceed 3,200 m (10,500 ft.).

The design mission was for cruise at  $M = .8$  at a ceiling of 11,582. m (38,000 ft.). The airplane achieved a cruise L/D ratio of 25.2; approximately 25% better in performance than with LFC system inoperative. The total fuel required for the 10,192.5 km (5500 n. mi.) mission was 56,698.7 kg (125,000 lbm.).

Structural integration of the LFC system slots, i.e., ducting and plenum compartment, was evaluated. Two structural materials, aluminum and titanium, were evaluated and compared. The results of this design study indicates that LFC can be effectively integrated into the wing structure using both standard aluminum and advanced titanium technology and the titanium technology can be expected to yield a lighter weight design.

INTRODUCTION

The Aircraft Energy Efficiency (ACEE) Program Office, LRC, has proposed a program to focus the application of emerging technologies that, by 1985, will provide the basis for the design of advanced subsonic transport aircraft requiring substantially less fuel than current designs. One of the most promising of the new technologies under consideration is Laminar Flow

Control (LFC). The LFC system prevents the formation of turbulent flow by pulling the slow-moving turbulent air, adjacent to the wing surface, through slots, internal ducts/pumps and then discharging this suction air behind the wing trailing edge. The proper application of this technology can effect significant fuel savings and increase the range capability.

The purpose of this document is to provide an assessment for LFC-project decisions on the application of LFC to candidate commercial aircraft designs. The objective of this engineering design study was to perform the necessary design and analyses work to provide an integrated wing configuration including all the subsystem interfaces plus those special requirements related to the LFC systems.

The study approach was to first conduct an evaluation of candidate LFC aircraft configurations. A baseline 200 passenger, 10,192.5 km (5500 n. mi.) airplane, which incorporates an aspect ratio 10 wing with laminar flow control, was selected for the design study. The emphasis in this engineering design effort was placed on LFC wings of metal technology. The first wing used the standard aluminum technology. The aluminum wing was compared with a recent development in metallic titanium technology--superplastic formed diffusion bonded titanium process (SFDB). Both wings incorporated similar suction-slot concepts.

#### SYMBOLS

The analysis computations in support of this study were performed in U.S. Customary (English) units. Results were converted to the International System of Units (SI) by using conversion factors in reference 1 and are presented in this report along with the Customary Units.

$AR_W$	Wing Aspect Ratio
ATA	Aviation Transport Association
$\bar{c}$	Chord (streamwise) at M.A.C.
c	Chord
$C_L$	Lift Coefficient
$C_Q$	Nondimensional Suction Coefficient
EI	Bending Stiffness, lb.-in <sup>2</sup>
F.A.R.	Federal Air Regulation
g	Gravitational Constant
GJ	Torsional Stiffness, lb.-in <sup>2</sup>
L/D	Lift-to-Drag Ratio
M.A.C.	Mean Aerodynamic Chord
M	Mach Number
NARUVL	North American Rockwell Unified Vortex Lattice
$S_H$	Horizontal Tail Area
$S_V$	Vertical Tail Area

$S_w$	Wing Area
$t/c$	Thickness/Chord
TSFC	Thrust Specific Fuel Consumption, $\frac{\text{lb/hr fuel}}{\text{lb thrust}}$
$U_o$	Undisturbed free-stream velocity component normal to wing
$V$	Velocity
$V_{\text{wall}}$	Boundary Layer Velocity at wall
$\eta$	Percent Semi-span
$\rho_{\text{amb}}$	Ambient Density
$\rho_{\text{wall}}$	Boundary Layer Density at wall
$\lambda$	Wing Taper Ratio
$\Lambda$	Wing Sweep

## DISCUSSION

### LAMINAR FLOW CONTROL (LFC) WING

#### TECHNICAL DATA

#### System Design Study Cycle Chart:

The Laminar Flow Control (LFC) in-house system design studies were conducted as shown in the cycle chart of figure 1. The basic study input decisions were derived from related in-house efforts. The study aircraft configuration and mission characteristics are shown in reference 2. This reference study involves the preliminary design and evaluation of a 200 passenger commercial aircraft with laminar flow control for a range of 10,192.5 km (5500 n. mi.). This work focused on configuration definition, powerplant size selection and the evaluation of aerodynamic characteristics, mass properties and performance. The wing airfoil for this study was developed by the Theoretical Aerodynamics Branch of NASA/LRC, Subsonic/Transonic Aerodynamic Division. The wing structural materials selected for comparison in this study are an aluminum skin/stringer concept and a recent development in titanium fabrication as shown in reference 3. These basic study input decisions formed the guidelines for the design and system integration tasks. Then the candidate design was iterated (see figure 1) to optimize on mission performance and economics.

#### Baseline LFC-Aircraft Configuration:

The baseline LFC-aircraft configuration is illustrated in figure 2. This aircraft concept was configured for 200 passengers plus baggage, 4,535.9 kg (10,000 lbm.) of cargo, with fuel volume to meet a 10,192.5 km (5500 n. mi.) mission range. This aircraft configuration exhibits the following features:

- o 7 abreast seating (2-3-2 two aisles)
- o laminar flow control on upper and lower wing surfaces from the leading edge aft to 78% of the chord
- o all mission fuel contained in the wing

- o three high by-pass ratio type engines, aft fuselage mounted
- o two laminar flow control suction units, one each in wing mounted nacelles
- o T-tail
- o cargo space for 4,535.9 kg (10,000 lbm.) of cargo in the fuselage under the passenger compartment
- o two hundred passenger seats spaced at 86.36 cm (34 in.) pitch with 50.8 cm (20 in.) wide aisles. A fuselage diameter of 490.2 cm (193.0 in.) satisfies this arrangement with sufficient head room for passengers seated and standing in the aisles.
- o a F.A.R. take-off field length not to exceed 3,200 m (10,500 ft.)

#### LFC-Aircraft Configuration Geometry Data:

The baseline aircraft configuration is comprised of an aspect ratio 10 wing with a 25 degree quarter chord sweep, a constant streamwise thickness ratio of 12.7% and a specially designed NASA/LRC airfoil section. Other specific parameters for the horizontal tail, vertical tail, powerplants and fuselage are listed in figure 3.

#### Mission Performance:

The design mission objectives (see figure 4) consist of a range of 10,192.5 km (5500 n. mi.) with 23,496. kg (51,800 lbm.) payload at  $M = .8$  and a maximum F.A.R. take-off field length of 3,200 m (10,500 ft.). For this configuration the cruise altitude is 11,582 m (38,000 ft.) and the laminar lift to drag ratio is 25.2. The total mission fuel of 56,698.7 kg (125,000 lbm.) includes the amount required by the LFC units and a reserve as specified by the ATA for international flights. The case of a LFC system failure at the mid-point of the design mission range was also investigated. A range loss of approximately 1,111.9 km (600 n. mi.) was experienced.

#### Wing Planform-Aluminum Wing:

The design effort was focused on the baseline aircraft wing planform depicted in figure 5. Standard metal technology was used in the aluminum wing design. The fine lines (of constant percent chord) shown in the planform view represents the suction slots. The increased number of lines near the leading edge and near the trailing edge is the result of increased suction required for those areas. The suction system engine is located just inboard from the M.A.C. at the break point in the trailing edge. In Sec. A-A, the suction engine nacelle size is minimized by fairing into the upper and lower wing surface just aft of the rear spar. The engine centerline is positioned near the wing reference plane.

Control surfaces consist of inboard and outboard spoilers and an outboard aileron. The trailing edge high lift system consists of a 25 percent chord double-slotted flap system.

#### Wing Planform-SFDB Titanium:

The application of a recent development in titanium technology (reference 3) to the same wing planform (figure 6) was compared with the aluminum wing.

The suction system for the titanium wing was the same as for the aluminum wing. Neither concept utilized suction aft of the 78% chord because of interference with spoilers and flaps. In Sec. A-A, the suction engine and nacelle are beneath the wing reference line thereby providing a clean upper surface.

The wing controls consist of inboard and outboard spoilers and an outboard aileron. The trailing edge high lift system consists of a 15 percent chord vane-flap system.

#### Structural Concept-Aluminum Skin/Stringer Wing:

This LFC wing uses an integrated structural concept with T-type stringer/ducts bonded or fastened to the aluminum skin as shown in "Detail A" of figure 7. The T-stringers are capped on the backside to form the suction-air ducts. This design technique results in very little structural weight penalty for the suction air distribution system. The rib/skin shear tie between stringers is shown in "Section X-X" where the rib web bonds to the skin. Access into the wing box is provided on the bottom surface through a series of doors shown in "Detail B." These doors are accessible through the removal of a spanwise skin-panel.

The slot-plenum arrangement with typical dimensions is shown in "Detail C" of figure 7. A thin aluminum surface strip is shown bonded over close tolerance grooves that are machined in the wing surface. The top surface and pre-cut slot is coated with "Tufram" protective coating to protect against corrosion and erosion processes. The "Tufram" protective coating is a patented anodizing process, developed by the General Magna Plate Corporation, that converts an aluminum surface to one that is very hard, is resistant to corrosion, abrasion, moisture, and is self-lubricating.

#### Structural Concept - SFDB Titanium Wing:

The LFC titanium wing (figure 8) uses an integrated superplastically formed diffusion bonded truss-core panel concept. The wing structure consists of a series of spanwise continuous panels joined by spanwise T-sections. The truss-core panel structure is shown in "View A" and the suction slot, plenum and metering hole arrangement in "View B." The plenum configuration is formed during the forming process and the metering holes are pre-drilled. The spanwise suction slots are cut in the outer titanium skin in the corner of the appropriate truss-core cell after fabrication of each titanium panel. Access into the wing box is provided through a removable spanwise panel as shown in "View C." Structural fail-safe provisions are made by integrated crack stoppers and spanwise stiffeners.

#### Wing Suction Slot Distribution:

The LFC suction slot spacing is shown in figure 9 for a wing cross-section at the M.A.C. location. The slot spacing decreases significantly near the leading edge and aft of the rear spar because of the higher suction requirements in these areas. The LFC suction distribution, represented by a coefficient  $C_Q$ , for the wing upper and lower surface is also presented

in figure 9. Incorporation of the spoilers and flap system dictated that the suction slots be terminated at the 78% chord location. Based on the suction distribution shown, 53 suction slots are required for the upper surface and 50 suction slots are required for lower surface. The Reynolds number (based on slot width) for the air flow through the slots was maintained at a value of 90 over the entire wing surface.

#### Integral Stringer-Duct Suction System - Aluminum Wing Concept:

As shown in figure 10 the suction air internal distribution is primarily in the spanwise direction where the air flows from the wing tip and the side of body intersection to the centerline of the suction engine plenum compartment. In "Section A-A" the suction engine is located vertically near the wing reference plane to allow the plenum ducts to pass through the rear spar web and to minimize the engine nacelle size. The upper surface air is directed into the low pressure plenum where it feeds the suction engine's low pressure compressor and the high pressure air from the lower surface is directed into the high pressure plenum where it feeds the high pressure compressor in the suction engine. The section forward of the front spar uses a Y-type manifold duct to smoothly direct air into the plenums. The section aft of the rear spar uses a large contoured manifold to introduce the air into the plenums just ahead of the compressor stages. The suction engine gas generator is fed by ram air and all LFC suction air is by-passed and exhausted aft of the wing trailing edge.

#### Truss-Core Duct Suction System - SFDB Titanium Wing Concept:

This suction air distribution system in figure 11 is similar to the aluminum wing concept where air flows from the wing tip and the side of body to the plenum compartment. Also the truss-core structural panels form the spanwise ducts for the flow of LFC suction air. Each truss-core duct uses a local manifold duct that directs the air into the plenum. The plenum is located in a dry bay that is approximately 71.12 cm (28 in.) wide. The upper surface air is directed through elbows into the low pressure compressor and the lower surface air is directed in a like manner into the high pressure compressor. In this concept the suction engines are located beneath the wing mold line with the nacelle interfacing the wing lower surface only, thereby providing a clean upper surface.

#### Upper Surface LFC Concept:

Independent studies have shown that approximately 70 percent of the wing friction drag occurs on the upper wing surface. The concept shown in figure 12 describes the wing cross-section where LFC is applied on just the upper surface. This allows an efficient leading edge device (Krueger-type shown) which, in combination with a simple trailing edge device, provides increased high lift capability. Also, the leading edge device provides an excellent insect shield during the take-off and landing phases. The lower surface of the wing utilizes standard aluminum technology and would provide ready access into the wing box region. This concept would reduce the suction complexity and suction engine size. Overall, a lighter weight and simpler design for the LFC wing would be realized by the application of LFC on just the upper surface.



### Structural Wing Loads:

A simplified loads analysis was performed to allow preliminary sizing of the wing structural parts. A 2.5 g positive maneuver acceleration was selected as the critical load condition for wing box sizing. This positive maneuver condition provided the most critical loading of the wing structure on a typical present day commercial transport aircraft (reference 4) that is similar in configuration to the baseline LFC aircraft. Limit load values are indicated by the curves of figure 13.

### Spanwise Lift Distribution:

The lift distribution for the baseline LFC aircraft wing was derived using the NARUWL wing lift program (reference 6). This spanwise airload distribution in figure 14, when compared with reference 5, shows a slight inboard shift of the spanwise center of pressure.

### Leading-Edge High-Lift Systems:

The leading-edge high-lift system presented in figure 15 is a slat concept which will allow suction on both the upper and lower surfaces of the wing in the leading edge region. The system is deployed on a track which is attached to a false spar located at the 8% chord position. In the stored position the track does not extend past the front spar located at the 18% chord position. Air is sucked from the slat by means of a telescoping air duct. This same duct or one mounted internal to this duct may be used in the de-icing system. Exact details of the slat geometry must be defined by wind tunnel model tests.

A Krueger-type high-lift system was selected to be used in conjunction with a LFC wing with suction only on the upper surface. The Krueger shown in figure 16 is positioned to have a 2% chord gap and 0% chord overlap. The exact position would be determined using a wind tunnel model.

A Krueger-type device would make it very difficult to provide LFC on the lower surface in the leading edge region due to the volume needed for the complex linkage. The system can, however, be practically integrated into a wing with LFC on just the upper surface. This device would also provide a shielding effect for the leading edge that may prevent insect contamination of the surface.

### Trailing-Edge High Lift Systems:

The aluminum wing design employs a 25% chord double slotted fowler-type, flap (figure 17) high lift system in conjunction with a 10% chord flight and ground spoiler. Using an internal track system, the flap system is capable of achieving a minimum 10% chord extension through the fowler action. This system is estimated to have a take-off  $C_L$  of 1.0 and an approach  $C_L$  of 1.8 (2.5 with a leading edge device).

The titanium wing design employs a 15% vane-flap high lift system (figure 18) with a flight and ground spoiler. This system is capable of achieving a minimum 10% chord extension through the fowler action. The system is estimated to have a take-off  $C_L$  of .90 and an approach  $C_L$  of 1.70.

#### Suction Powerplant Concept:

The LFC suction powerplant selected is a turboshaft engine (figure 19) that is connected to low pressure and high pressure axial flow compressors. Low pressure air from the upper wing surface enters the low pressure compressor from which it discharges into a mixing chamber where it combines with the high pressure air from the lower wing surface. The combined air then passes through the high pressure compressor, bypasses the turbine, and is exhausted at approximately free stream velocity, aft of the wing trailing edge.

#### Wing Bending Stiffness Comparison:

Figure 20 shows the LFC-wing bending stiffness distribution from the wing tip to the wing/body intersection. The cross-hatched band represents estimated values from previous studies. Discrete calculated points from the structural analysis of this study are shown for the aluminum and titanium wings. The titanium wing has 15% greater bending stiffness than the comparable aluminum wing.

#### Wing Torsional Stiffness Comparison:

Figure 21 shows the LFC-wing torsional stiffness distribution from the wing tip to the wing/body intersection. The cross-hatched band represents estimated values from previous studies. Specific calculated points of this study are plotted for the aluminum and titanium wings. The titanium wing has over 20% greater torsional stiffness than the comparable aluminum wing.

#### Baseline Aircraft Weight Fractions:

The chart in figure 22 shows the statistical weight estimate of the baseline LFC aircraft with an aluminum wing. The LFC wing was estimated to weigh 24,947.4 kg (55,000 lbm.), which included a weight penalty (increase) of 7.32 kg/M<sup>2</sup> (1.5 lb/ft<sup>2</sup>) of wing area for the LFC suction surface and ducting system plus 907.2 kg (2000 lbm.) concentrated weight for each suction engine.

### CONCLUDING REMARKS

The NASA-LFC wing in-house design study findings are as follows:

- o The LFC wing-integral stringer/duct technique provides an efficient LFC concept.
- o Extent of laminarization aft of the wing rear spar significantly impacts the total suction flow and suction engine size.
- o Advanced turboshaft engine technology is necessary for a viable wing mounted concept.
- o A double-slotted fowler-type flap system can be integrated into a LFC wing.
- o Integration of a leading edge slat with suction appears to be feasible.

- o LFC on just the upper surface of the wing allows integration of L.E. and T.E. high lift devices, normal wing access, lower weight and less suction system complexity.
- o The superplastic formed-diffusion bonded (SFDB) titanium structural concept can be integrated into a LFC wing.
- o The SFDB-titanium wing with LFC has higher bending and torsional stiffness characteristics than the aluminum wing with LFC, and can be expected to yield a lighter weight design.

This design study effort concluded that the extent of wing laminarization should end near the 80% of the wing chord. This location allows laminarization to be contained in a fixed wing structure immediately aft of the rear spar and forward of movable panels such as ailerons, flaps and spoilers.

The SFDB titanium technique results in an attractive LFC-wing concept that has increased stiffness characteristics that are important for high aspect ratio wing structures. Further development and manufacture of large flight quality panels are required in order to commit this technology to actual flight aircraft design and fabrication.

## REFERENCES

1. Mechtly, E. A.: The International System of Units-Physical Constants and Conversion Factors (second revision), NASA sp-7012, 1973.
2. Vought Corp., HTC: ACEE Laminar Flow Control Reference Airplane Data, Prepared under Contract NAS1-13500, February 4, 1977.
3. Rockwell International Corp.: Laminar Flow Control Wing Structure, Prepared under Contract NAS1-14566, March 8, 1977.
4. NASA CR-144950, A Preliminary Design Study of a Laminar Flow Control Wing of Composite Materials for Long Range Transport Aircraft.
5. NASA TR-921, Theoretical Symmetric Span Loading at Subsonic Speeds For Wings Having Arbitrary Plan Form.
6. Tulinus, J.: The Unified Subsonic, Transonic and Supersonic NAR Vortex Lattice TFD-72-523, Los Angeles Division, North American Rockwell, January 26, 1973.

FIGURE 1  
LFC, IN-HOUSE SYSTEM DESIGN STUDIES

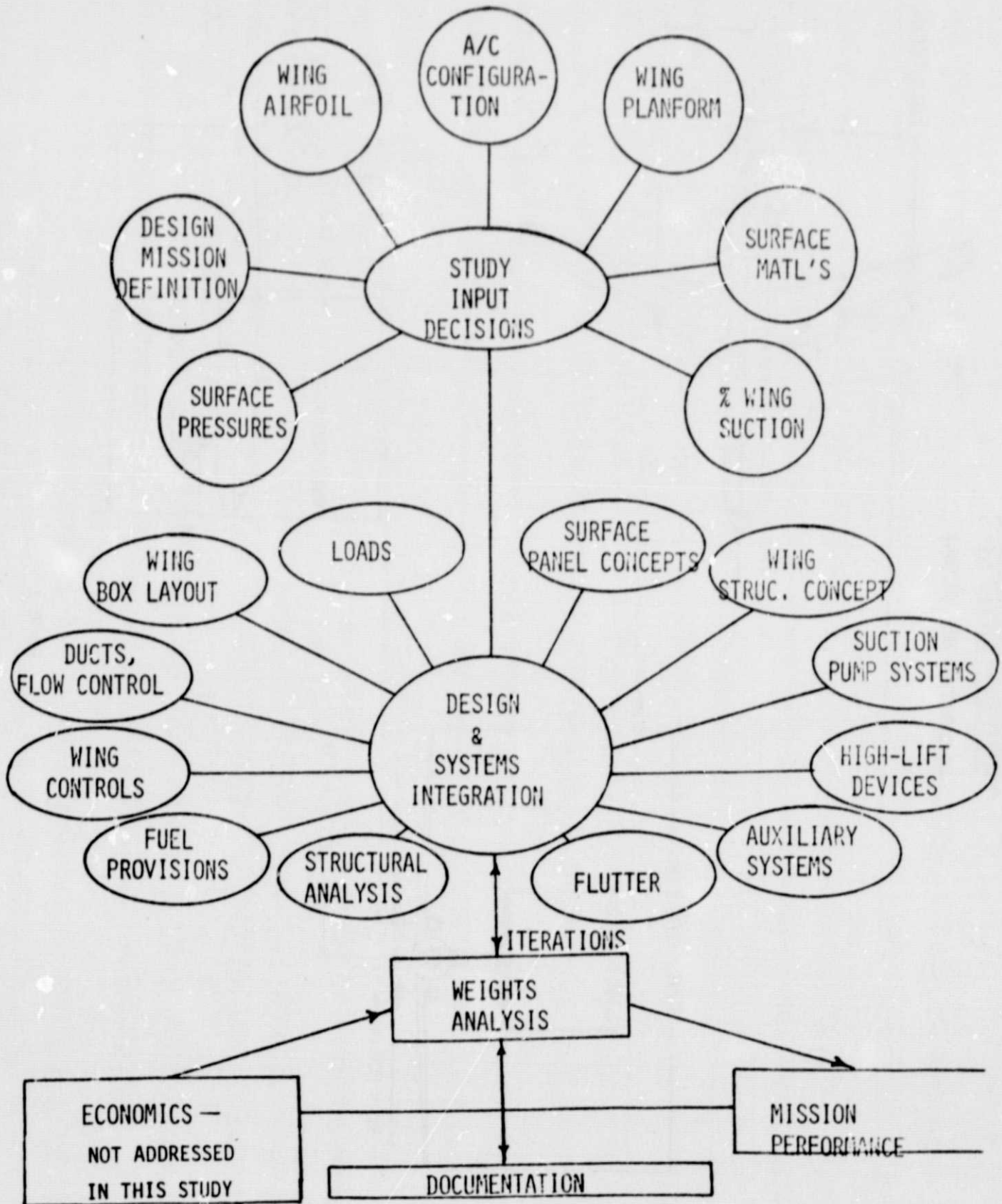

LFC-AIRCRAFT CONFIGURATION 3 VIEW  
(200 PASSENGER REFERENCE A/C)

ALL DIMENSIONS ARE: CM (IN.)

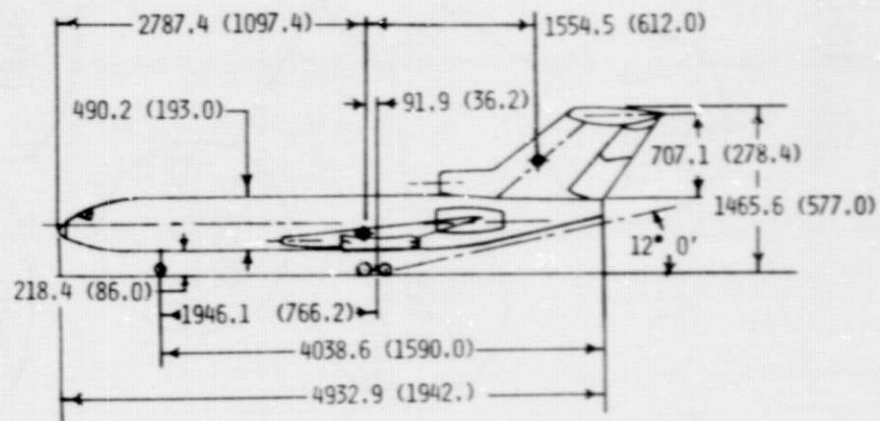
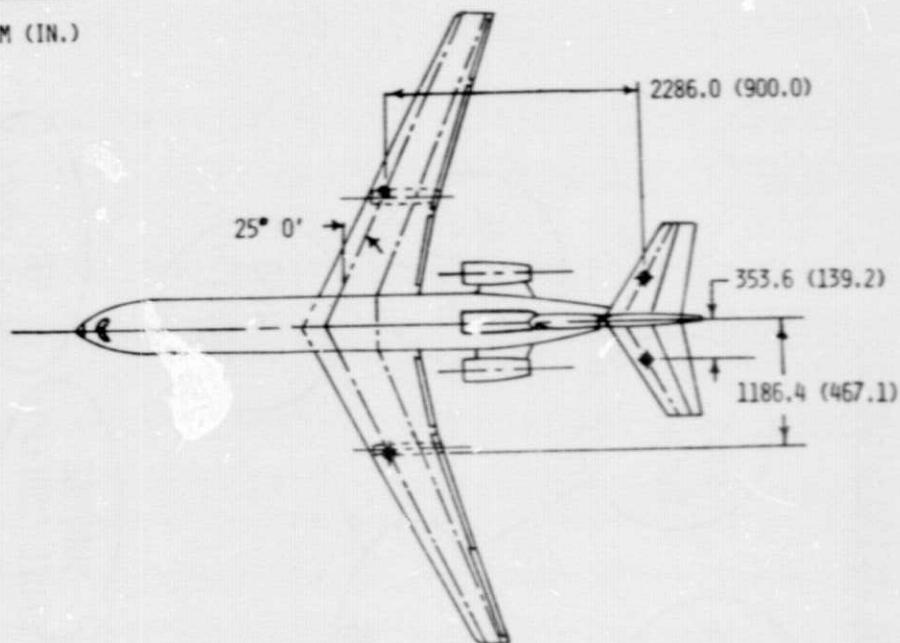
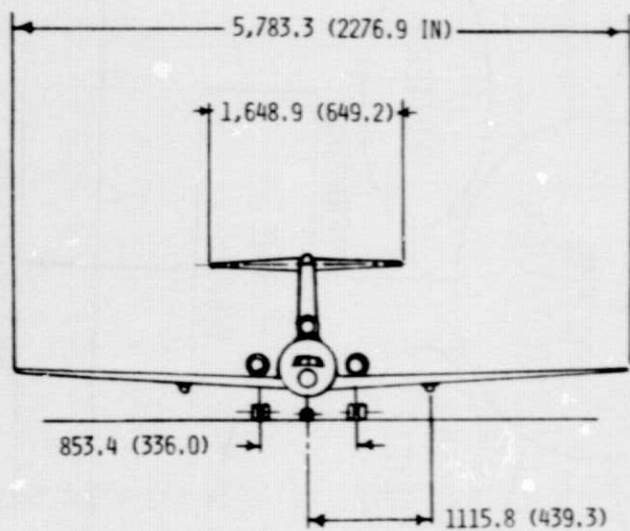

FIGURE 2

## GEOMETRY DATA

### WING

$S_w = 334.5 \text{ M}^2 \text{ (3600 ft}^2\text{)}$   
 $AR_w = 10$   
 $\text{taper}_w = .3$   
 $\text{sweep}_w @ 1/4 C = 25^\circ$   
 $t/c_w \text{ streamwise} = 12.7\%$

$\text{span}_w = 57.83\text{m (189.74 ft)}$   
 $\text{root chord}_w = 8.90 \text{ m (29.29 ft)} (@ A/C C_L)$   
 $\text{tip chord}_w = 2.67 \text{ m (8.76 ft)}$   
 $M.A.C._w = 6.34 \text{ m (20.8 ft)}$

### HORIZONTAL TAIL

$s_h = 83.61 \text{ m}^2 \text{ (900 ft}^2\text{)}$   
 $AR_h = 3.25$   
 $\text{taper}_h = .40$   
 $\text{sweep}_h @ 1/4 C = 30^\circ$   
 $t/c_h @ \text{root} = 11\%$   
 $t/c_h @ \text{tip} = 9\%$   
 $\text{vol. coeff} = .90$

$\text{span}_h = 16.49 \text{ m (54.1 ft)}$   
 $\text{root chord}_h = 7.25 \text{ m (23.8 ft)}$   
 $\text{tip chord}_h = 2.90 \text{ m (9.5 ft)}$   
 $M.A.C._h = 5.39 \text{ m (17.7 ft)}$   
 $\text{moment arm} = 22.86 \text{ m (75 ft)}$

### VERTICAL TAIL

$s_v = 75.69 \text{ m}^2 \text{ (804 ft}^2\text{)}$   
 $AR_v = .67$   
 $\text{sweep}_v @ 1/4 C = 50^\circ$   
 $t/c_v @ \text{root} = 11\%$   
 $t/c_v @ \text{tip} = 9\%$   
 $\text{vol coeff.} = .06$

$\text{span}_v = 7.67 \text{ m (23.2 ft)}$   
 $\text{root chord}_v = 8.4 \text{ m (27.6 ft)}$   
 $\text{tip chord}_v = 8.41 \text{ m (27.6 ft)}$   
 $M.A.C._v = 10.70 \text{ m (35.1)}$   
 $\text{moment arm} = 15.54 \text{ m (51 ft)}$

### POWERPLANTS

sealevel/stand. day take-off  
thrust per engine = 12,246.9 kg (27,000 lbs) installed

FIGURE 3

FUSELAGE

length = 49.32 m (161.8 ft)  
maximum dia. = 4.91 m (16.1 ft)

FIGURE 3 CONTINUED



## MISSION PERFORMANCE

MISSION: DESIGN (M = .8)

MODEL: LFC BASELINE AIRCRAFT

### AIRCRAFT CHARACTERISTICS

TAKE-OFF GROSS WEIGHT	165,424. KG (364,700 LBM)	
OPERATING WEIGHT EMPTY	85,229. KG (187,900 LBM)	
PAYLOAD (GROSS)	23,496. KG ( 51,800 LBM)	(200 PASS. + 453.6 KG (10,000 LBM) CARGO)
WING AREA	( 3,600 FT <sup>2</sup> )	
S.L. STATIC THRUST PER ENGINE (STD DAY)		
UNINSTALLED	13,471.6 KG (29,700 LBM)	
INSTALLED	12,246.9 KG (27,000 LBM)	
TAKE-OFF INSTALLED THRUST TO WEIGHT RATIO	.22	
TAKE-OFF WING LOADING	334.5 KG/M <sup>2</sup> (101.3 LBS/FT <sup>2</sup> )	
TAKE-OFF FIELD LENGTH (MAX)	3,200. M (10,500 FT)	

### DESIGN MISSION

	OPERATING WEIGHTS		Δ FUEL		Δ RANGE		Δ TIME MIN
	KG	LBM	KG	LBM	KM	N.MI.	
TAKE-OFF	165,424.	(364,700)	635.	( 1,400)	0	(0)	11
START CLIMB	164,789.	(363,300)	5,624.	(12,400)	531.9	(287)	45
START CRUISE	159,165.	(350,900)	48,415.	(89,100)	9,334.5	(5037)	659
END CRUISE	118,750.	(261,800)	590.	( 1,300)	370.6	(200)	20
END DESCENT	118,160.	(260,500)					
TAXI-IN			227	( 500)	0	(0)	<u>5</u>
BLOCK FUEL AND TIME			47,491	(104,700)			740
TRIP RANGE					10,237.	(5524)	

FIGURE 4

MODEL: LFC BASELINE AIRCRAFT

RESERVE FUEL BREAKDOWN

	KG	LBM
1. 10% TRIP TIME	3,855.5	(8500)
2. MISSED APPROACH	453.6	(1000)
3. 370.6 KM (200 N.MI.) TO ALTERNATE AIRPORT	3,220.5	(7100)
4. 30 MIN. HOLDING AT 457.2M (1500 FT)	1,905.	<u>(4200)</u>
TOTAL RESERVE	9,434.7	(20800)

INITIAL CRUISE CONDITIONS:

LIFT COEFFICIENT		.5077
DRAG COEFFICIENT		.02012
LIFT/DRAG		25.24
TSFC .0683 KG/HR/N		(.670 LBS/HR/LBF)
ALTITUDE	11,643 M	(38200 FT)

FIGURE 4 CONTINUED

STANDARD TECHNOLOGY (ALUM.) WING

BASELINE LFC WING PLANFORM ASSEMBLY

DIMENSIONS SHOWN: CM (IN.)

ASPECT RATIO	10
AREA-S	334.5 M <sup>2</sup> (3600 FT <sup>2</sup> )
TAPER RATIO $\lambda$	0.30
SWEEP - C/4	25.0°
SPAN - B	57.8 M (189.74 FT)
ROOT CHORD - C <sub>R</sub>	8.89 M (29.19 FT)
TIP CHORD - C <sub>T</sub>	2.67 M (8.76 FT)
WING THICKNESS @ M.A.C.	12.76%

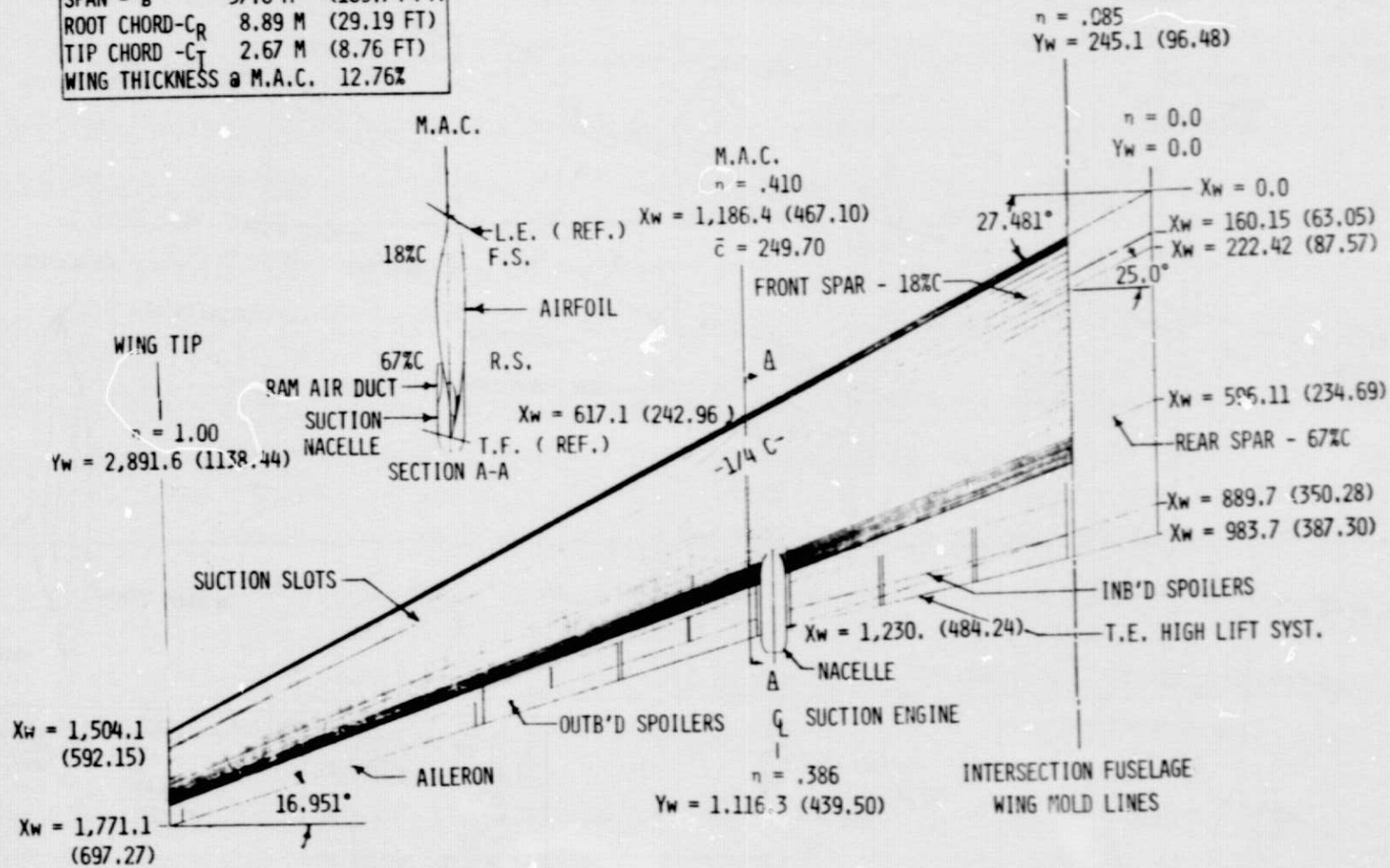

FIGURE 5

ORIGINAL PAGE IS  
 OF POOR QUALITY

BASELINE WING PLANFORM  
LFC  
TITANIUM IN-HOUSE DESIGN

DIMENSIONS ARE: CM(IN)

AREA - M <sup>2</sup>	S	334.5 (3600.00 FT <sup>2</sup> )
SPAN - CM	b	2891.6 (1138.44 IN)
SWEEP - .25 CHORD-DEG.	$\lambda$	25.00
ASPECT RATIO - NON-DIM.	AR	10.00
TAPER RATIO - NON-DIM.	$\lambda$	0.30
CHORD, ROOT - CM	CR	889.7 (350.38 IN)
CHORD, TIP - CM	CT	267.0 (105.12 IN)
WING THICKNESS @ M.A.C. - PER CENT	T/C <sub>w</sub>	12.70

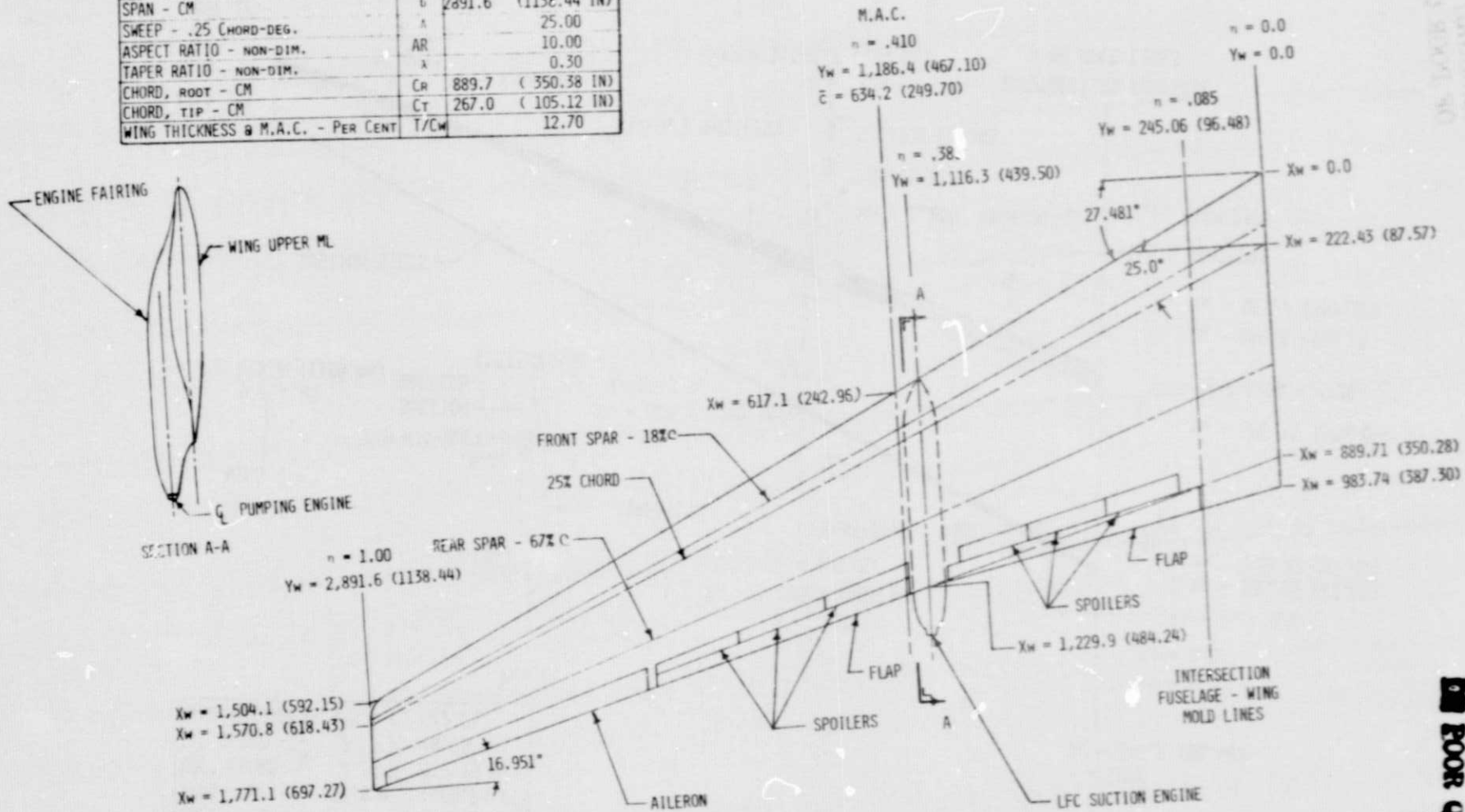

FIGURE 6

ORIGINAL PAGE IS  
POOR QUALITY

LFC STRUCTURAL CONCEPT  
ALUMINUM SKIN STRINGER

DIMENSIONS SHOWN: CM (IN.)

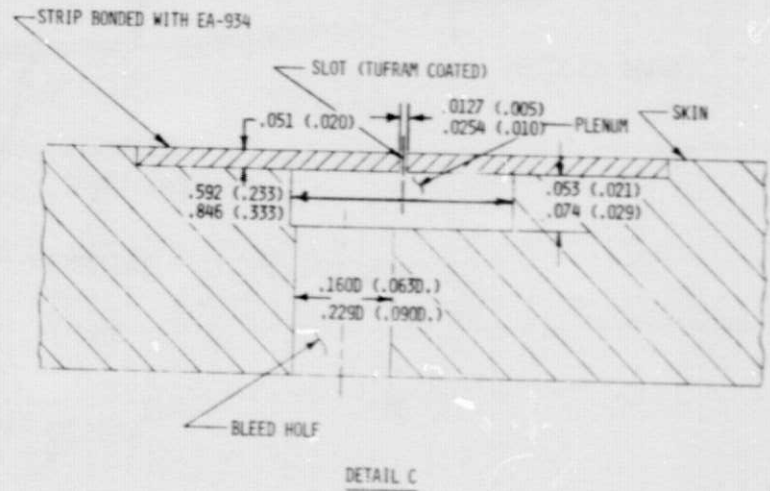
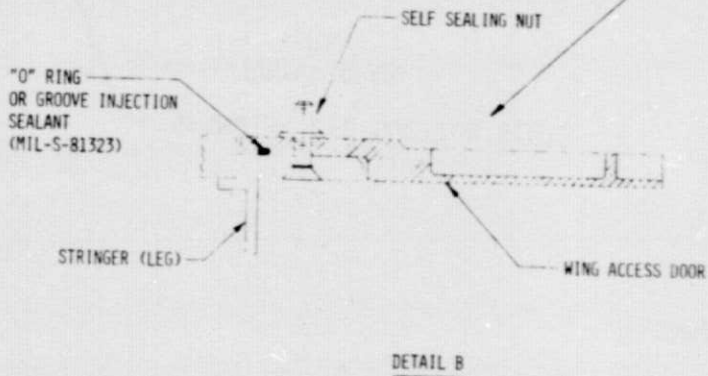
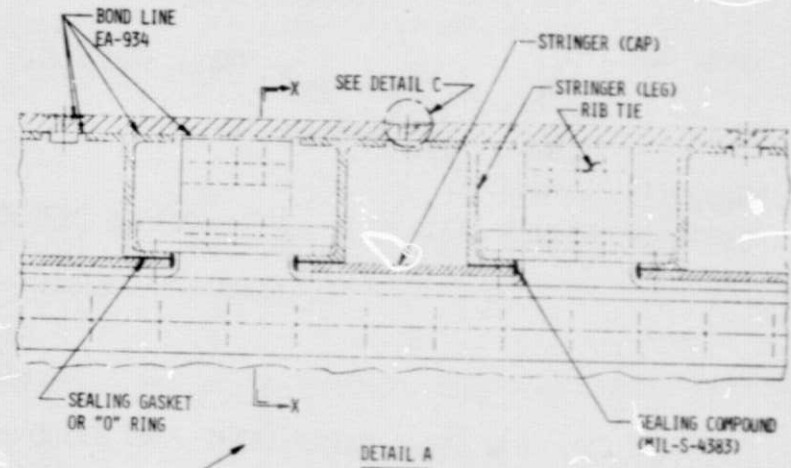
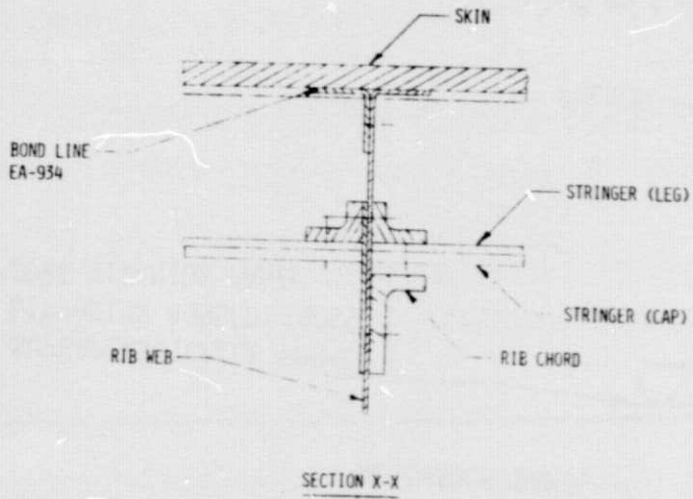

FIGURE 7

ORIGINAL PAGE IS  
OF POOR QUALITY

BASELINE SLOTTED WING STRUCTURAL CONCEPT

LFC

TITANIUM

IN-HOUSE DESIGN

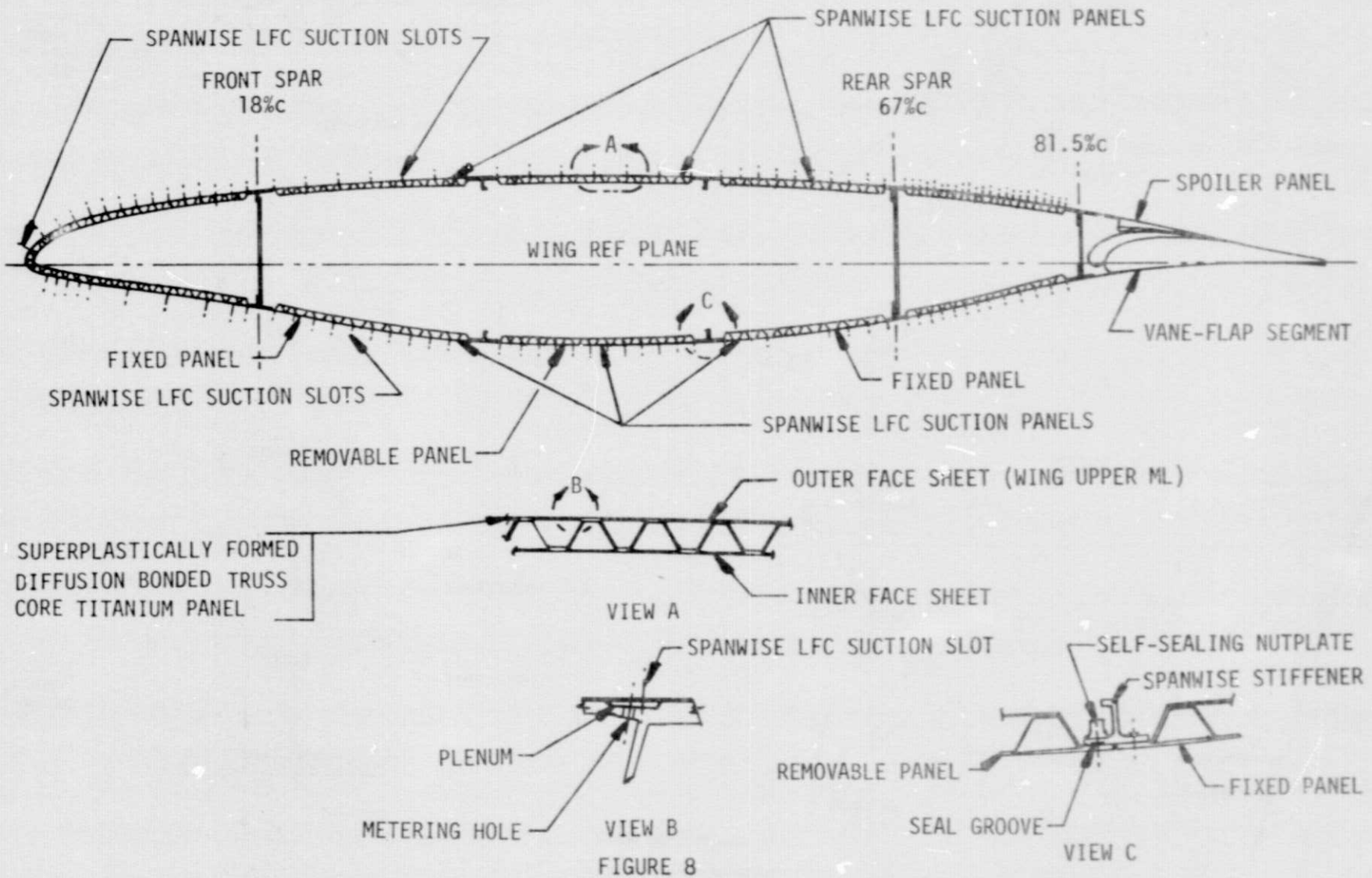

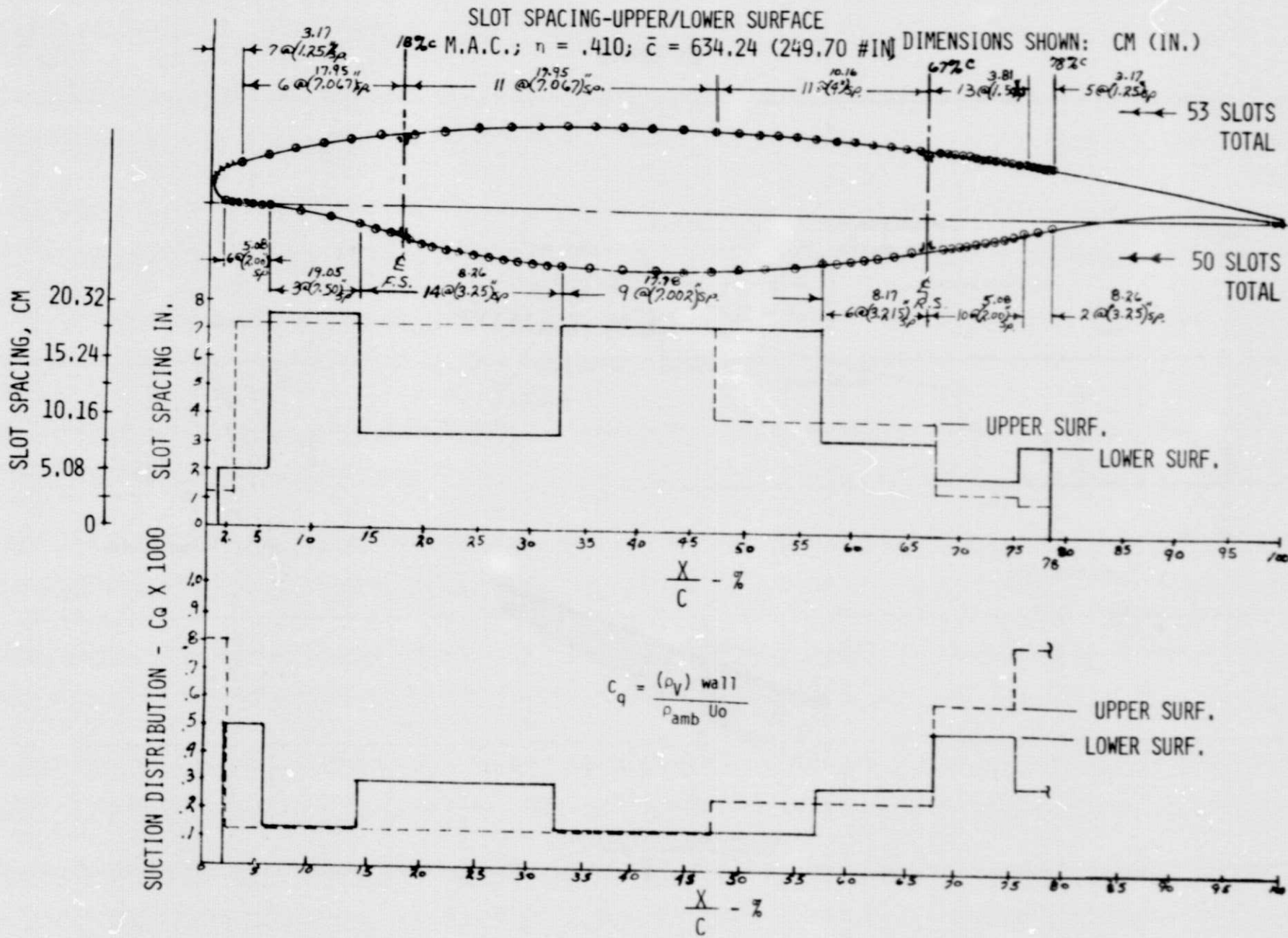

FIGURE 9

ORIGINAL PAGE IS OF POOR QUALITY

LFC INTEGRAL STRINGER-DUCT SUCTION SYSTEM

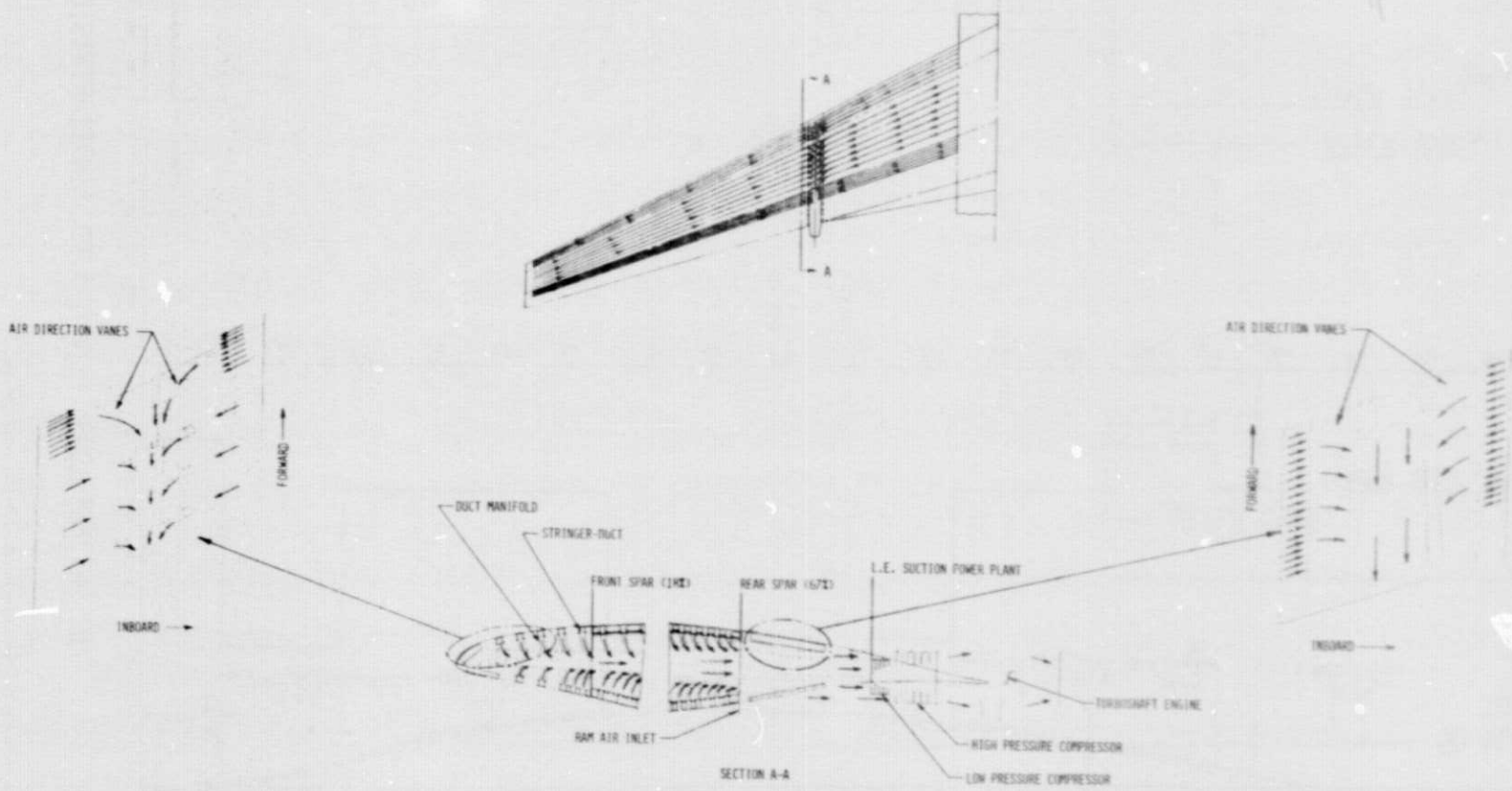

FIGURE 10

ORIGINAL PAGE IS  
OF POOR QUALITY



BASELINE WING  
LFC  
SCHEMATIC LAYOUT PUMPING SYSTEM  
TITANIUM IN-HOUSE DESIGN

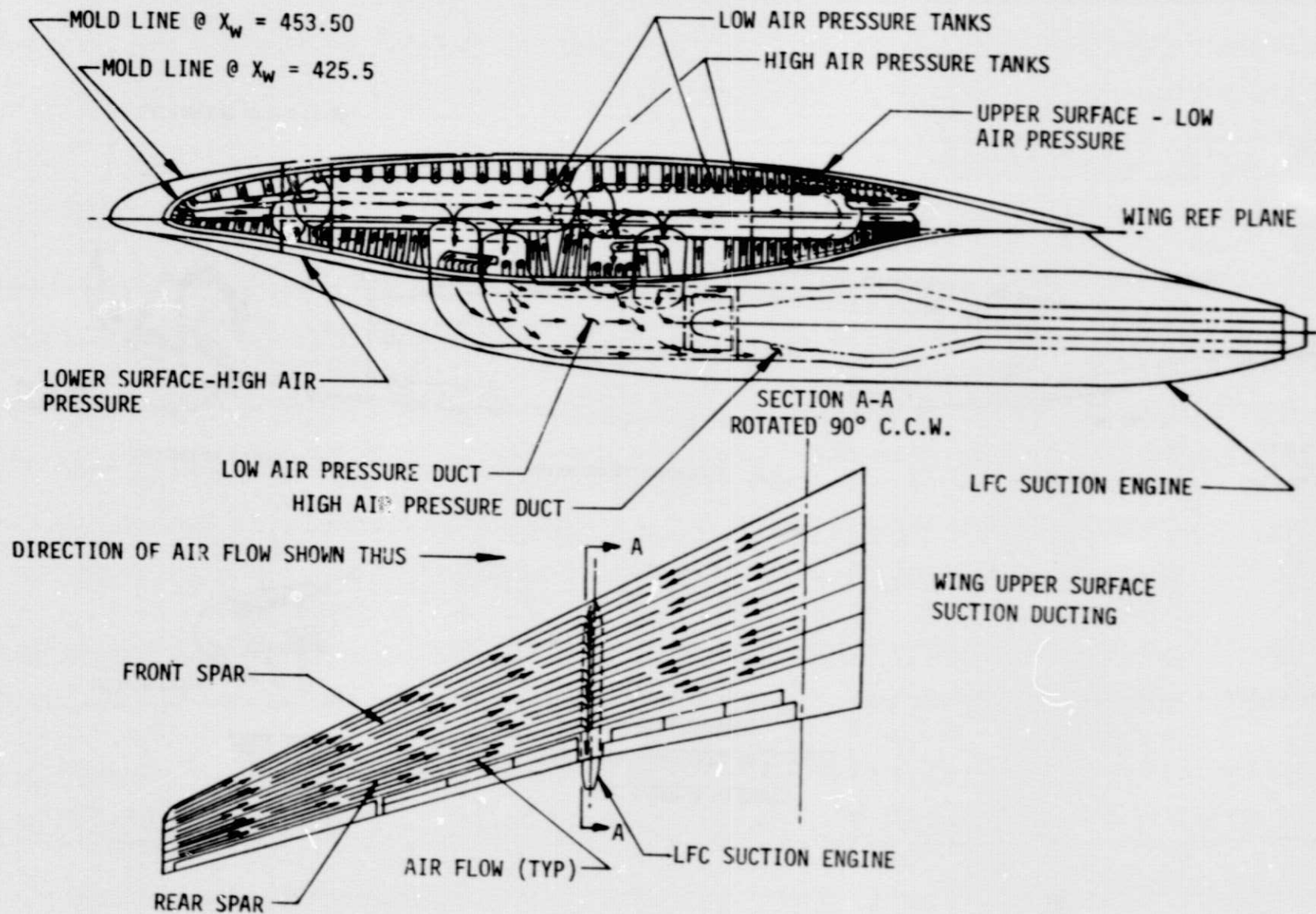
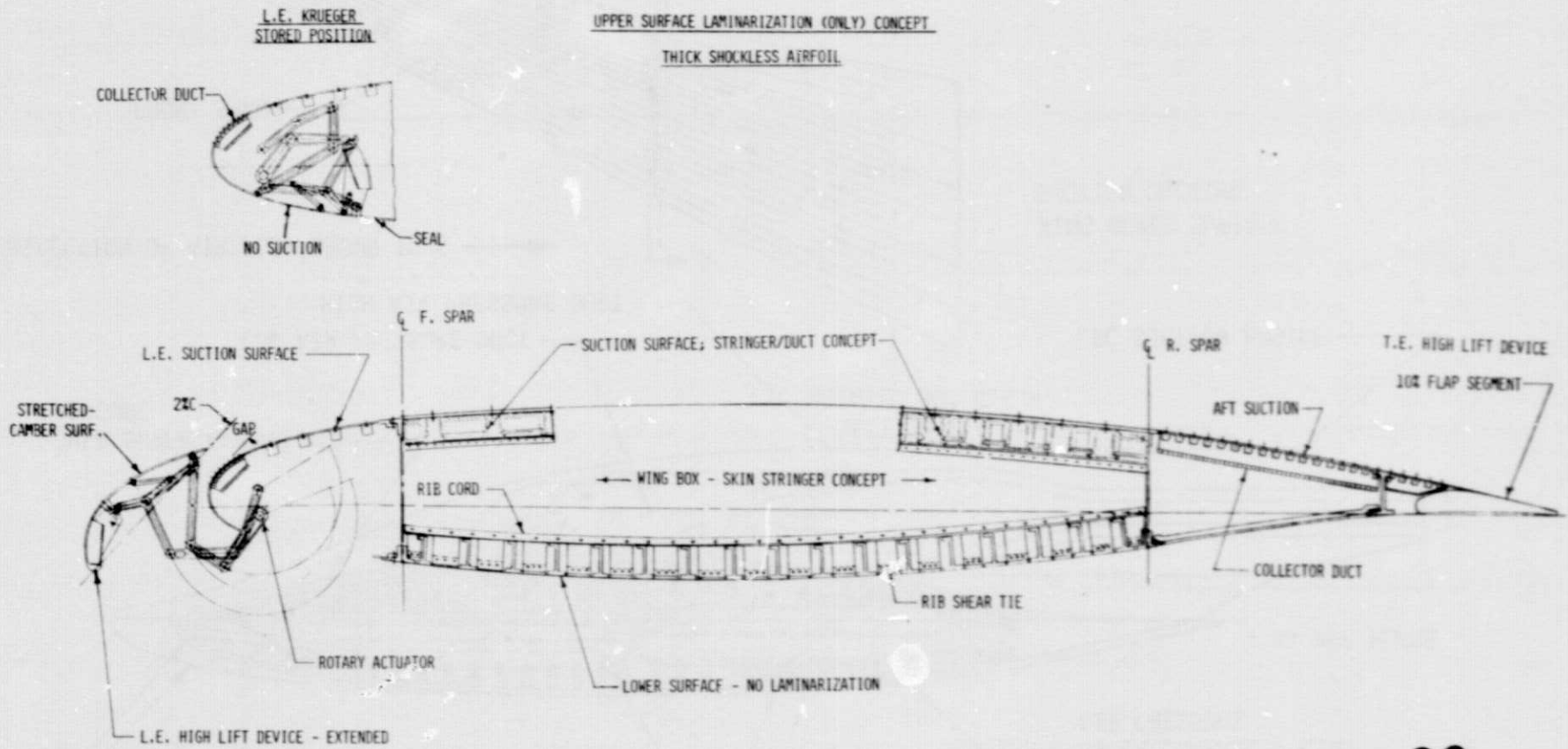

FIGURE 11

LFC - IN-HOUSE DESIGN STUDIES

UPPER SURFACE LAMINARIZATION (ONLY) CONCEPT

THICK SHOCKLESS AIRFOIL



ORIGINAL PAGE IS  
OF POOR QUALITY

FIGURE 12

LFC - STRUCTURAL WING LOADS  
 BASELINE CONFIGURATION

2.5 g BALANCED MANEUVER CONDITION

LIMIT LOAD  
 (NO FACTOR OF SAFETY)

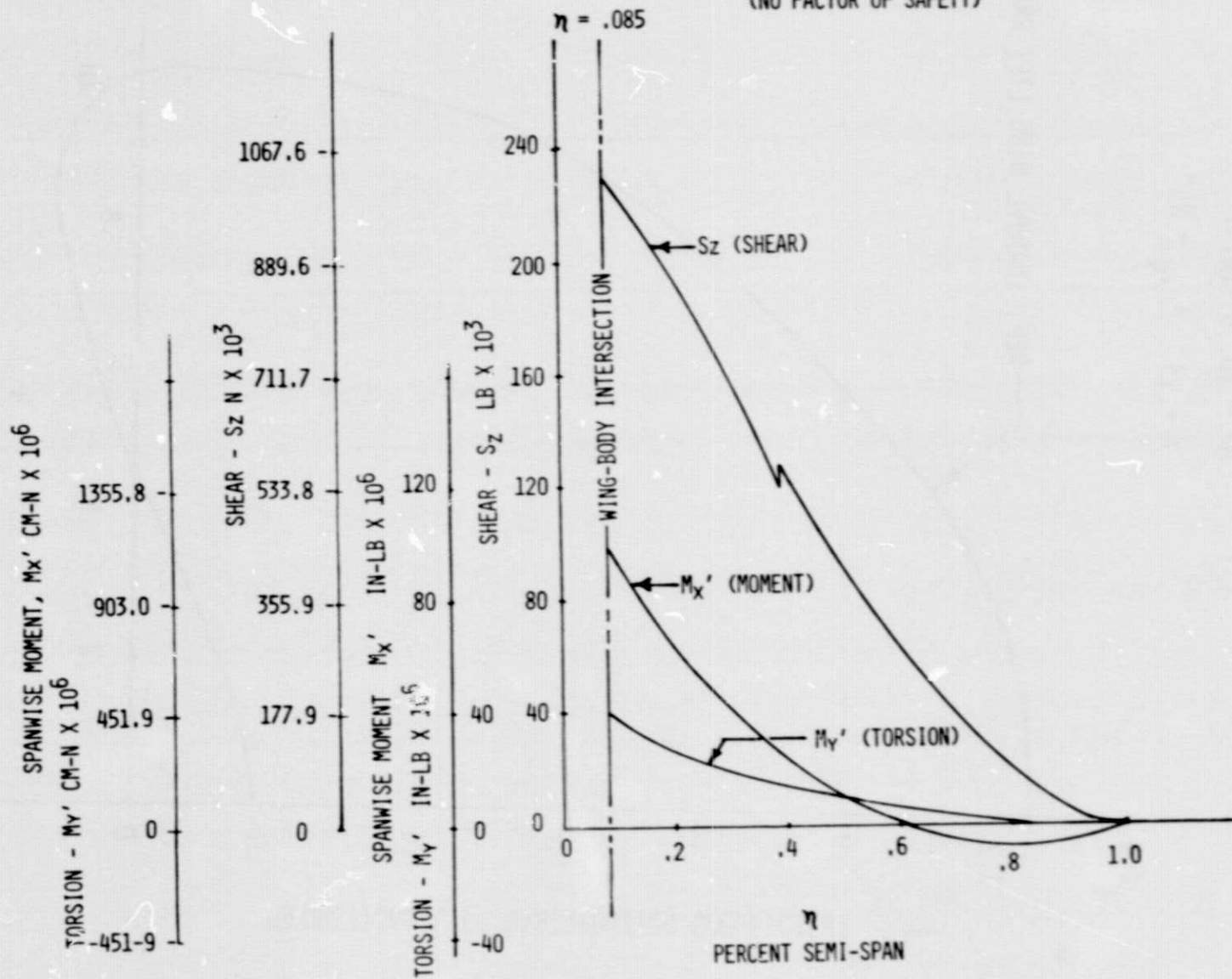

FIGURE 13

LFC-BASELINE WING

SPANWISE THEORETICAL LIFT DISTRIBUTION

AR = 10, 6° TWIST

$\lambda = .3$   $\Lambda_{c/4} = 25^\circ$

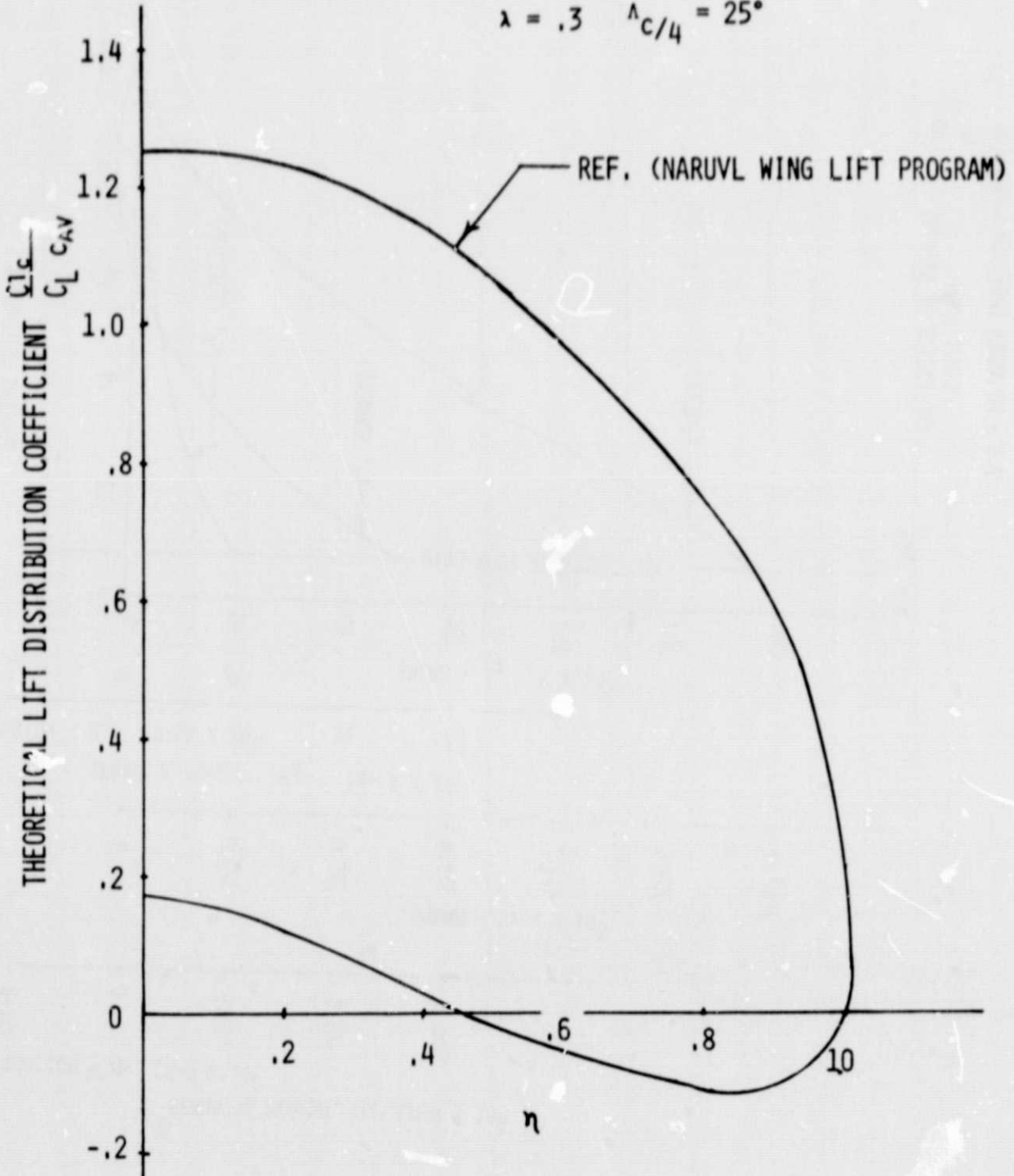
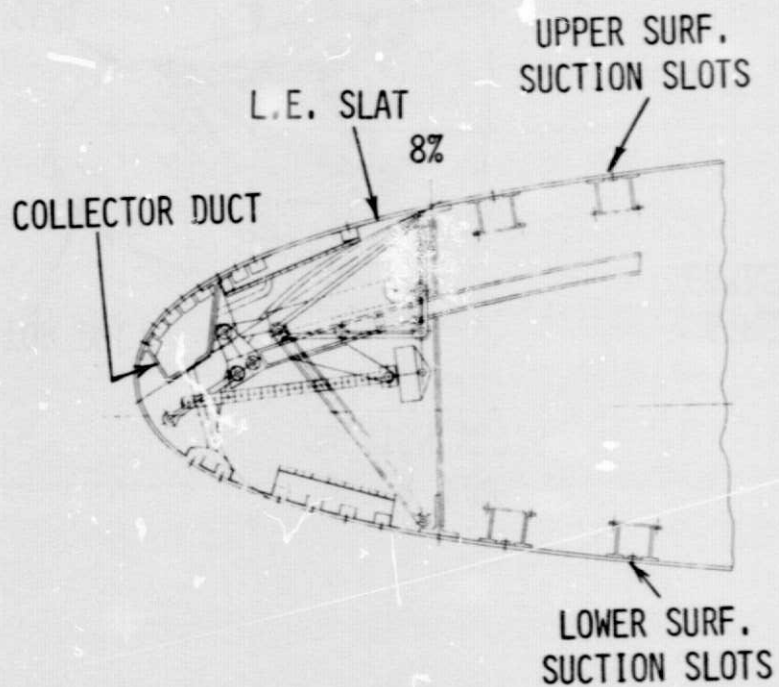
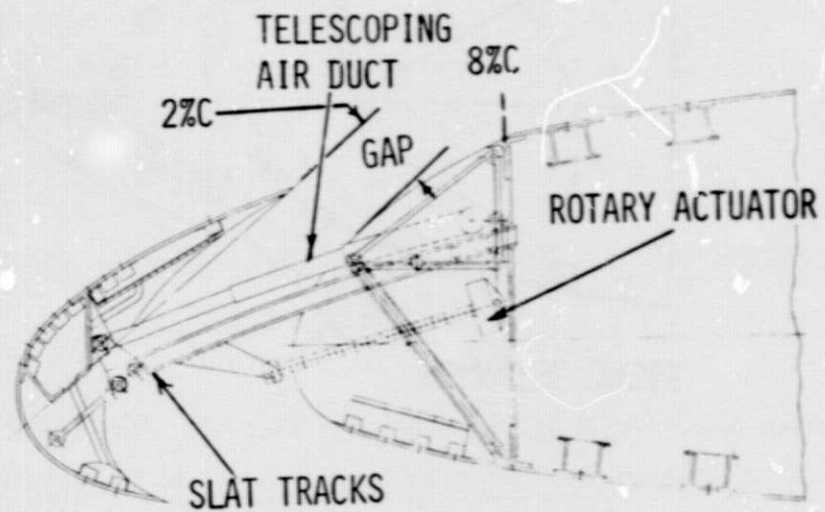

FIGURE 14

LEADING-EDGE SLAT HIGH-LIFT SYSTEM  
SUCTION CONCEPT



L.E. SLAT-SUCTION  
STORED POSITION



L.E. SLAT-SUCTION  
EXTENDED POSITION

FIGURE 15

LEADING-EDGE KRUEGER-TYPE HIGH-LIFT SYSTEM

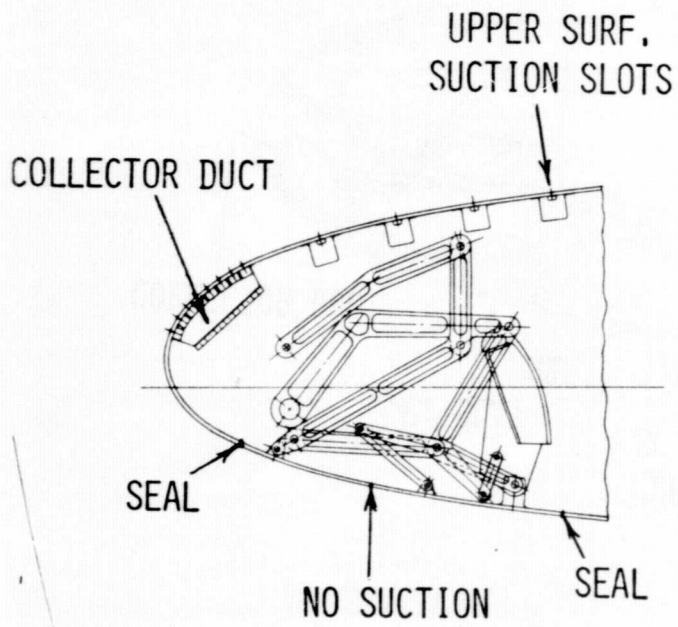

L.E. KRUEGER  
STORED POSITION

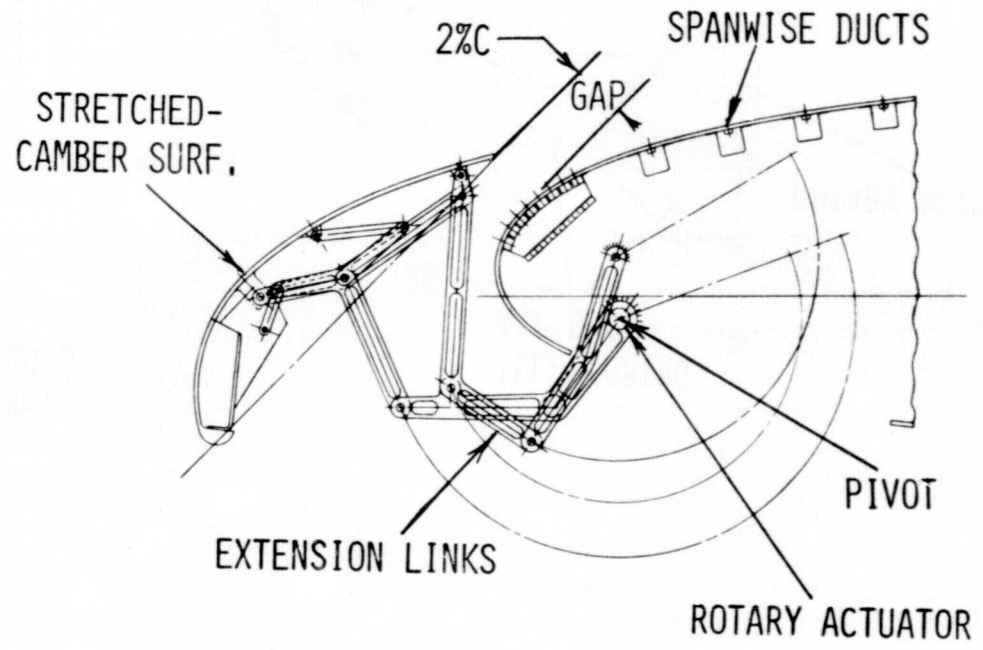

L.E. KRUEGER  
EXTENDED POSITION

FIGURE 16

TRAILING EDGE HIGH LIFT SYSTEM  
DOUBLE SLOTTED FLAP

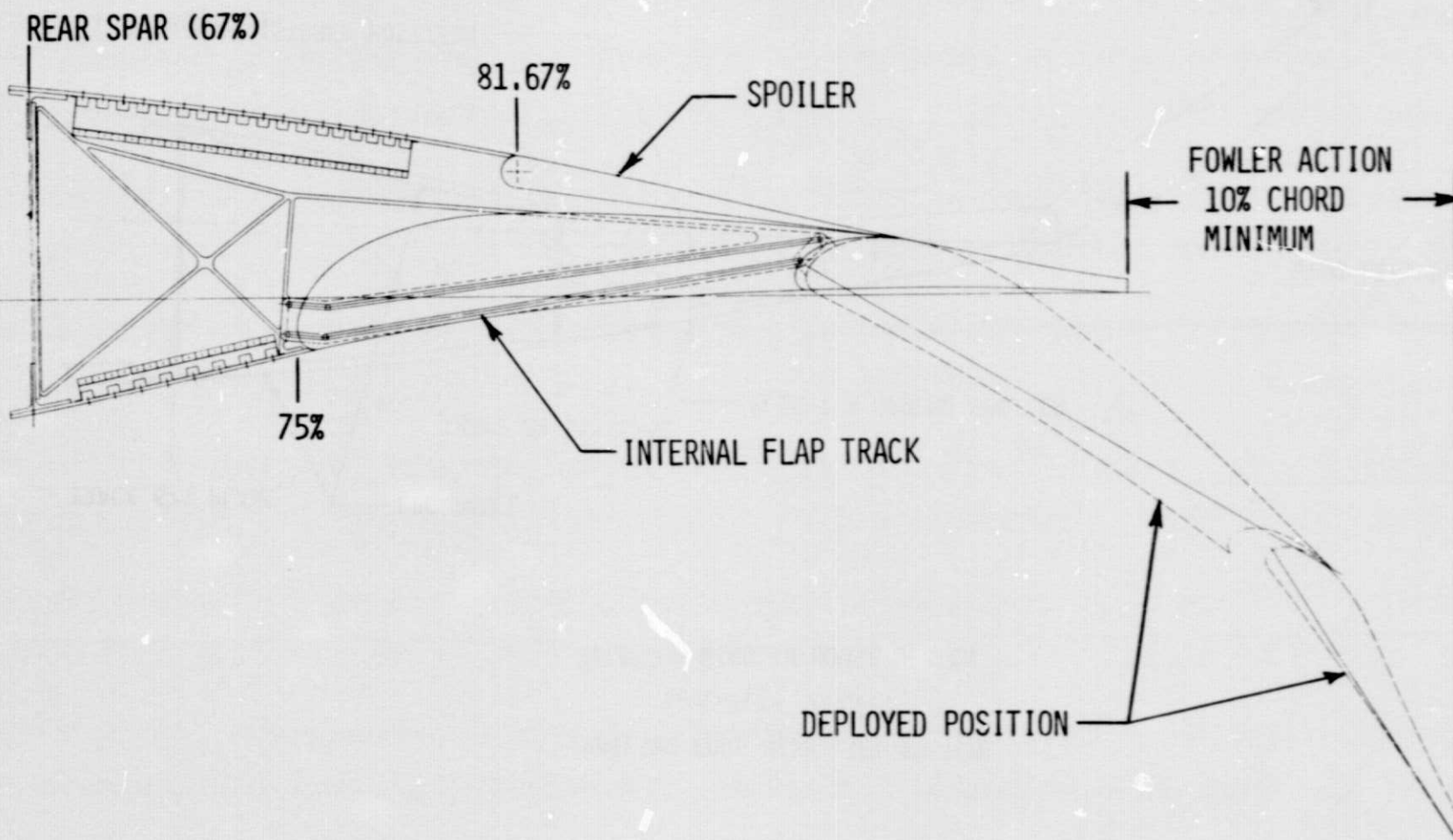

FIGURE 17

TRAILING EDGE HIGH-LIFT SYSTEM  
VANE-FLAP CONCEPT  
TITANIUM WING IN-HOUSE DESIGN

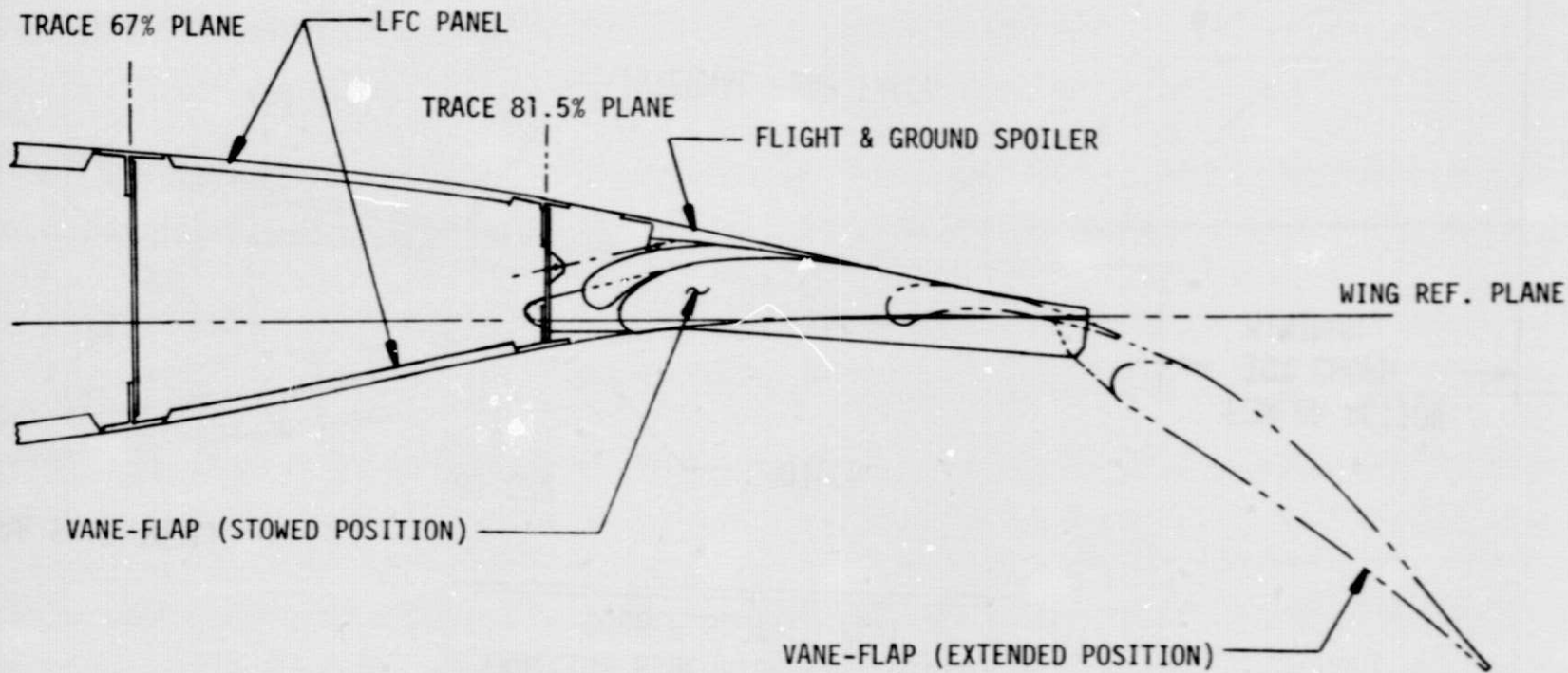

FIGURE 18



LFC SUCTION POWERPLANT CONCEPT

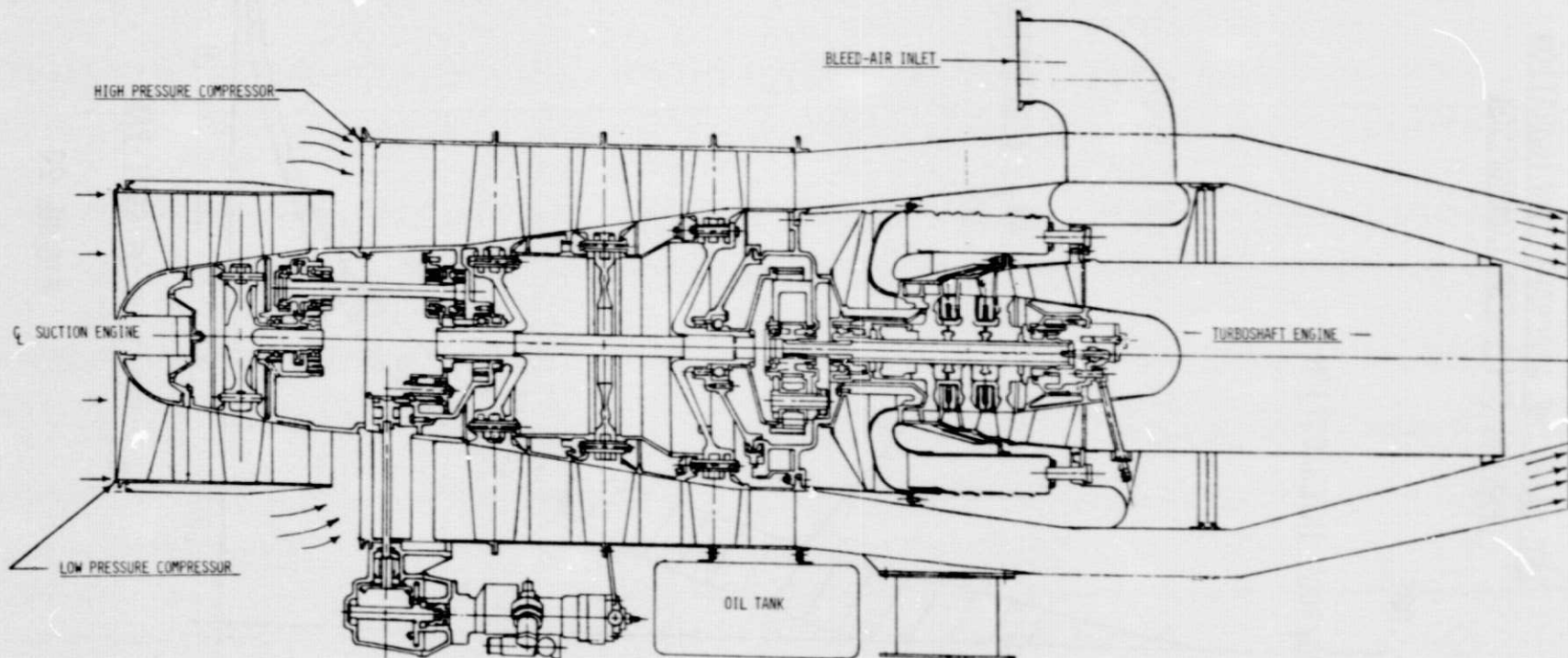

FIGURE 19

LFC-BASELINE AIRCRAFT CONFIGURATION  
 BENDING STIFFNESS COMPARISON

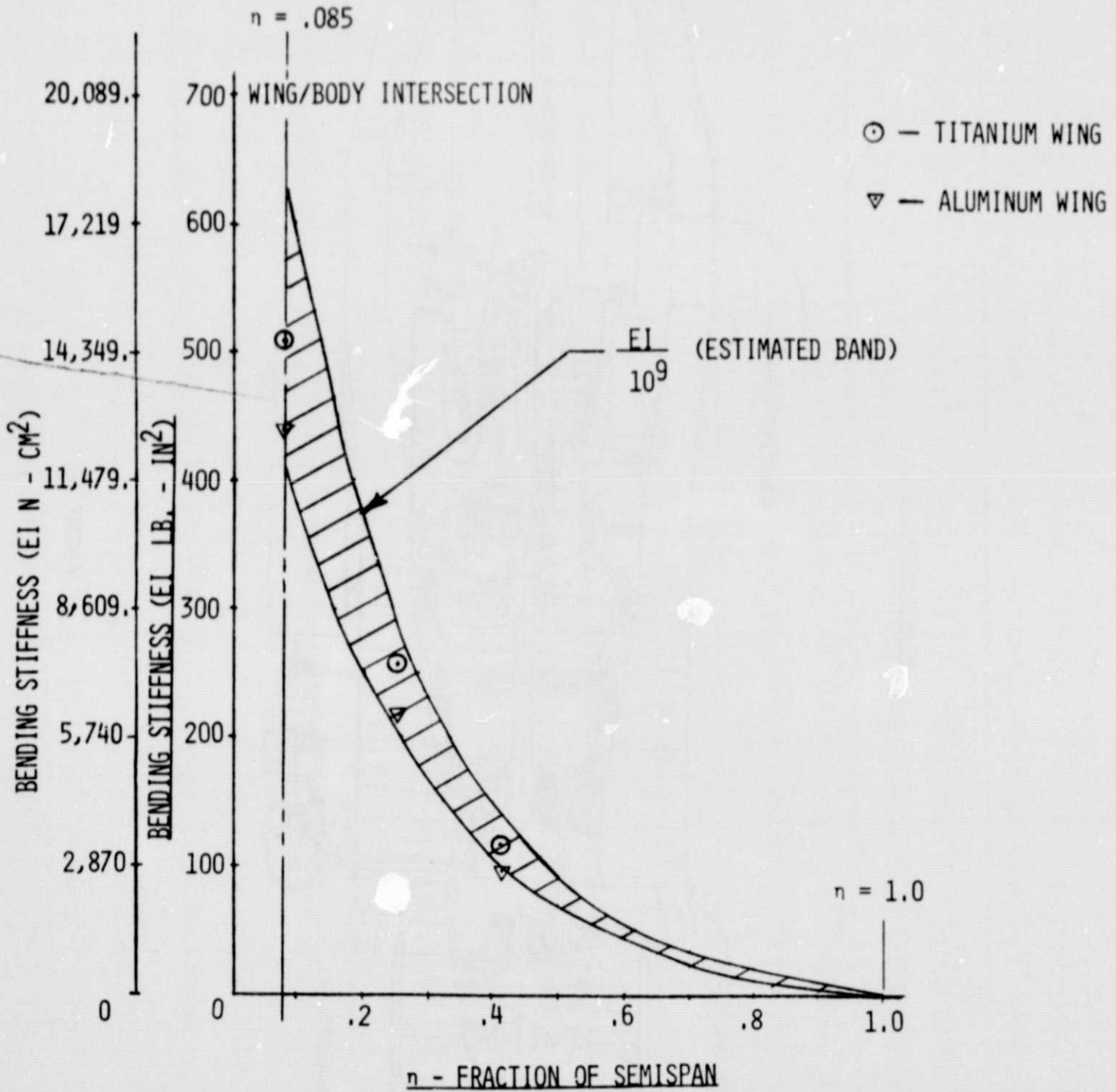

FIGURE 20

LFC-BASELINE AIRCRAFT CONFIGURATION  
 TORSIONAL STIFFNESS COMPARISON

$n = .085$

WING/BODY INTERSECTION

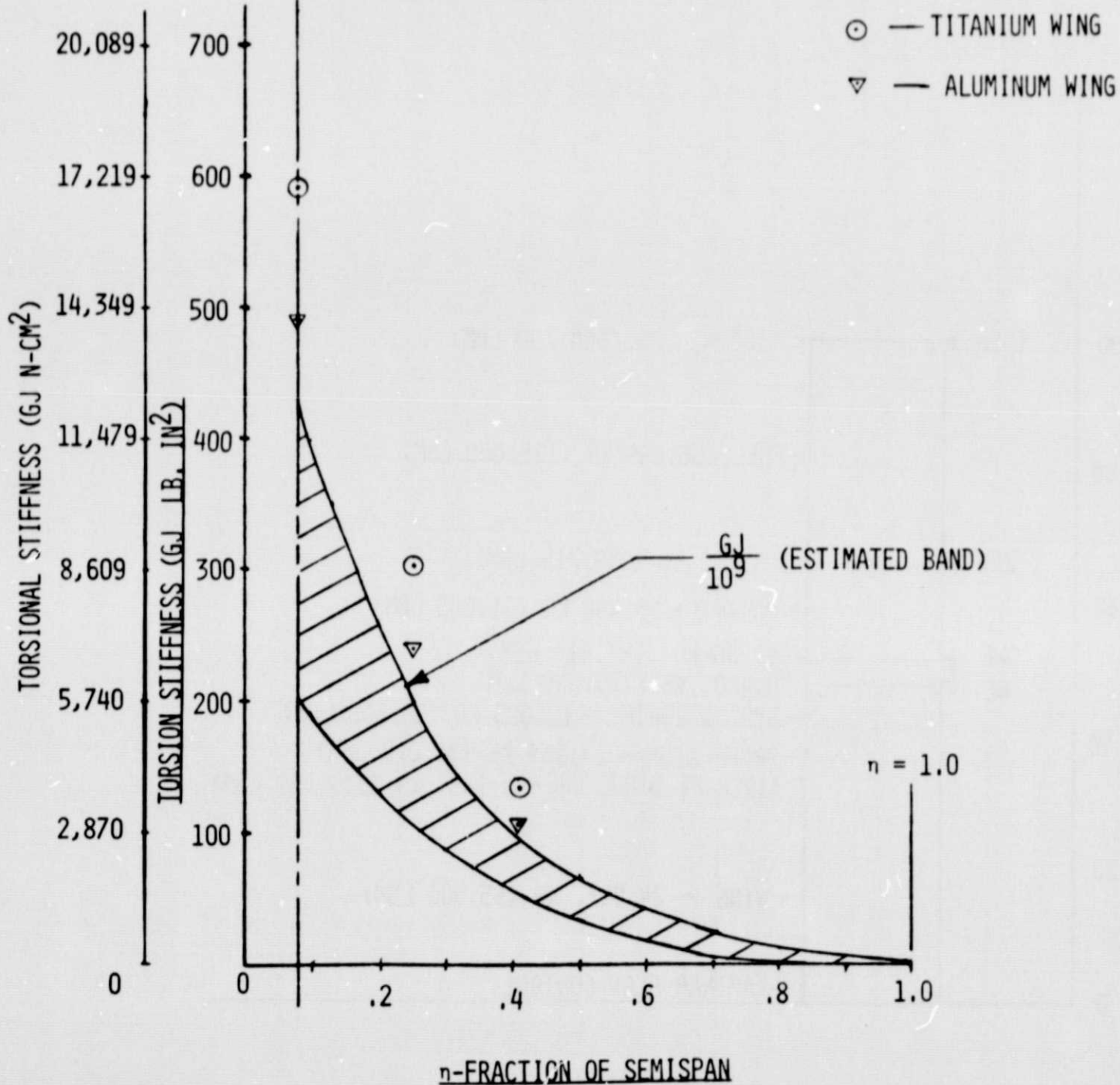

FIGURE 21

LFC - IN-HOUSE DESIGN STUDIES  
BASELINE AIRCRAFT WEIGHT FRACTIONS

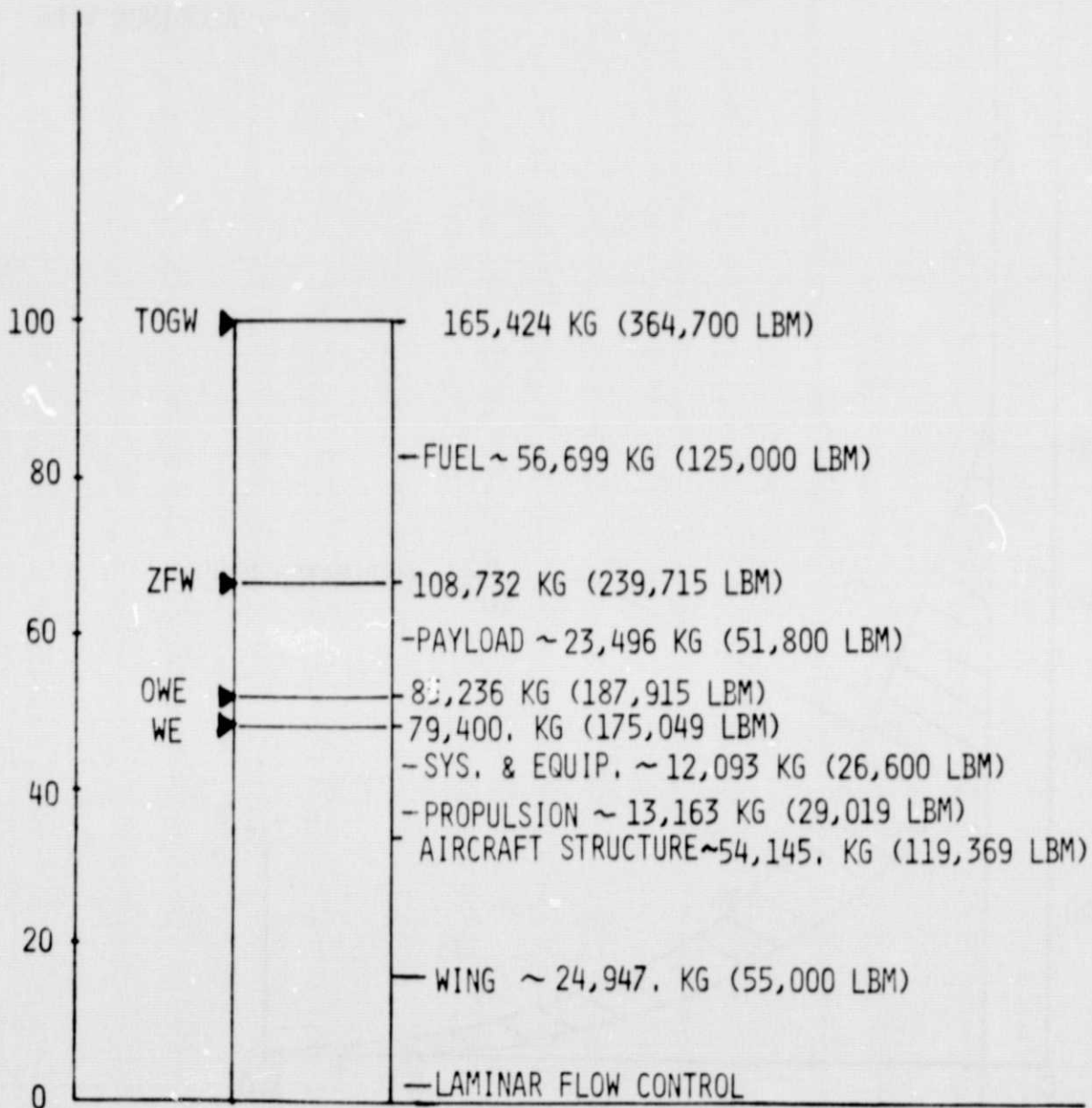

FIGURE 22

1. Report No. NASA TM 78634		2. Government Accession No.		3. Recipient's Catalog No.	
4. Title and Subtitle Aircraft Energy Efficiency Laminar Flow Control Wing Design Study				5. Report Date October 1977	
				6. Performing Organization Code 55.410	
7. Author(s) Tom F. Bonner, Jr., NASA, Langley Research Center Joseph D. Pride, Jr., " " " " William W. Fernald " " " "				8. Performing Organization Report No.	
				10. Work Unit No. 514-55-03-21	
9. Performing Organization Name and Address NASA, Langley Research Center Hampton, Virginia 23665				11. Contract or Grant No.	
				13. Type of Report and Period Covered Technical Memorandum	
12. Sponsoring Agency Name and Address National Aeronautics and Space Administration Washington, DC 20546				14. Sponsoring Agency Code	
				15. Supplementary Notes	
16. Abstract An engineering design study was performed in which Laminar Flow Control (LFC) was integrated into the wing of a commercial passenger transport aircraft. A baseline aircraft configuration was selected and the wing geometry was defined. The LFC system, with suction slots, ducting, and suction pumps was integrated with the wing structure. The use of standard aluminum technology and advanced Superplastic Formed-Diffusion Bonded (SFDB) titanium technology was evaluated. The results of the design study show that the LFC system can be integrated with the wing structure to provide a structurally and aerodynamically efficient wing for a commercial transport aircraft.					
17. Key Words (Suggested by Author(s)) Laminar Flow Control Aircraft Energy Efficiency Wing Slots, ducts, suction engines			18. Distribution Statement Unclassified-unlimited Star category <del>15</del> 05		
19. Security Classif. (of this report) Unclassified		20. Security Classif. (of this page) Unclassified		21. No. of Pages 33	22. Price* \$4.00