

D180-20689-5

Contract NAS9-15196
DRL Number T-1346
DRD Number MA-664T
Line Item 3

Solar Power Satellite

SYSTEM DEFINITION STUDY

Part 1 Volume V

**SPS Transportation:
Representative System Descriptions**

July 28, 1977

**Submitted to
The National Aeronautics and Space Administration
Lyndon B. Johnson Space Center
In Partial Fulfillment of the Requirements
of Contract NAS 9-15196**

Approved By:



**G.R. Woodcock
Study Manager**

**Boeing Aerospace Company
Missiles And Space Group
Space Division
P.O. Box 3999
Seattle, Washington**

FOREWORD

The SPS systems definition study was initiated in December 1976. Part I was completed on May 1, 1977. Part I included a principal analysis effort to evaluate SPS energy conversion options and space construction locations. A transportation add-on task provided for further analysis of transportation options, operations, and costs.

The study was managed by the Lyndon B. Johnson Space Center (JSC) of the National Aeronautics and Space Administration (NASA). The Contracting Officer's Representative (COR) was Clarke Covington of JSC. JSC study management team members included:

Lou Livingston	System Engineering and Analysis	Dick Kennedy	Power Distribution
		Bob Ried	Structure and Thermal Analysis
Lyle Jenkins	Space Construction		
Jim Jones	Design	Fred Stebbins	Structural Analysis
Sam Nassiff	Construction Base	Bob Bond	Man-Machine Interface
Buddy Heineman	Mass Properties	Bob Gundersen	Man-Machine Interface
Dickey Arndt	Microwave System Analysis	Hu Davis	Transportation Systems
R. H. Dietz	Microwave Transmitter and Rectenna	Harold Benson	Cost Analysis
		Stu Nachtwey	Microwave Biological Effects
Lou Leopold	Microwave Generators		
Jack Seyl	Phase Control	Andrei Konradi	Space Radiation Environment
Bill Dusenbury	Energy Conversion		
Jim Cioni	Photovoltaic Systems	Alva Hardy	Radiation Shielding
Bill Simon	Thermal Cycle Systems	Don Kessler	Collision Probability

The Boeing study manager was Gordon Woodcock. Boeing technical leaders were:

Vince Caluori	Photovoltaic SPS's	Jack Gewin	Power Distribution
Dan Gregory	Thermal Engine SPS's	Don Grim	Electric Propulsion
Eldon Davis	Construction and Orbit-to-Orbit Transportation	Henry Hillbrath	Propulsion
		Dr. Ted Kramer	Thermal Analysis and Optics
Hal DiRamio	Earth-to-Orbit Transportation	Keith Miller	Human Factors and Construction Operations
Dr. Joe Gauger	Cost		
Bob Conrad	Mass Properties	Jack Olson	Configuration Design
Rod Darrow	Operations	Dr. Henry Oman	Photovoltaics
Bill Emsley	Flight Control	John Perry	Structures

D180-20689-5

The Part I Report includes a total of five volumes:

Vol. I	D180-20689-1	Executive Summary
Vol. II	D180-20689-2	System Requirements and Energy Conversion Options
Vol. III	D180-20689-3	Construction, Transportation, and Cost Analyses
Vol. IV	D180-20689-4	SPS Transportation System Requirements
Vol. V	D180-20689-5	SPS Transportation: Representative System Descriptions

Requests for information should be directed to Gordon R. Woodcock of the Boeing Aerospace Company in Seattle or Clarke Covington of the Future Programs Division of the Johnson Space Center in Houston.

TABLE OF CONTENTS

	Page
1.0 Abstract	1
2.0 Summary	3
3.0 Introduction	5
4.0 Mission Requirements, Ground Rules, and Assumptions	9
5.0 Launch Vehicle Descriptions	11
5.1 2-Stage Ballistic Cargo Vehicle	11
5.2 2-Stage Winged Cargo Vehicle	65
5.3 Personnel Carrier Vehicle	121
5.4 Launch Vehicle Comparison Results	145
6.0 Orbit Transfer Vehicle Description	151
6.1 GEO Construction OTV's	151
6.2 LEO Construction OTV's	169
7.0 Development Plan	223
7.1 LEO Transportation System Development Plan	223
7.2 Orbit Transfer Vehicle Development Plan	226
8.0 Exhaust Product Analysis	229
9.0 Critical Commodities and Energy Requirements	233
9.1 LEO Transportation Critical Commodities and Energy Requirements	233
9.2 OTV Critical Commodities and Energy Requirements	237
10.0 Collision Analysis	239
10.1 Flux Model Analysis	239
10.2 Collision Analysis Results	241
10.3 Collision Avoidance Considerations	245
10.4 Junk Cleanup Concept	245
11.0 Transportation Cost Comparison and Sensitivities	247

D180-20689-5

1.0 ABSTRACT

The Solar Power Satellite (SPS) Study included an add-on task associated with the SPS transportation system requirements and system description. Both LEO transportation (earth to low earth orbit) and GEO transportation (low earth orbit to geosynchronous orbit) segments were addressed.

The LEO transportation options included both a 2-stage ballistic recoverable and a 2-stage winged space freighter vehicle. In addition, a personnel carrier vehicle for crew rotation has been defined. Both versions of the space freighter incorporated new $LO_2/RP-1/LH_2$ engines on the booster and standard SSME's on the upper stage. A tanker and cargo version of the 2-stage ballistic recoverable concept were investigated.

The orbit transfer vehicle (OTV) options included chemical for geosynchronous satellite assembly and self powered electric propulsion for low Earth orbit satellite assembly. A 2-stage fully reusable LO_2/LH_2 OTV was selected as the reference chemical orbit transfer system and an ion propulsion system for the electric propulsion option.

An exhaust products analysis was conducted for the earth to LEO launch vehicle since the potential atmospheric pollution could be a concern. Commodity and energy requirements were determined for the transportation system segments.

D180-20689-5

2.0 SUMMARY

The purpose of this study was to develop the SPS transportation system requirements (Volume 4); identify and describe candidate transportation systems; and to investigate the programmatic impacts of development, exhaust products and critical commodity and energy consumption. A summary evaluation of the transportation systems is presented in Figure 2-1.

Two Earth launch vehicle options were analyzed for delivery of satellite components and OTV systems: (1) A ballistic, two-stage sea recovery vehicle with a retractable payload shroud that could be 100% recovered; (2) A two-stage wing-wing vehicle that was 100% recoverable. Cost per flight for the ballistic system was \$19.50/Kg while the winged vehicle was estimated at \$20.80/Kg per flight. For the ballistic system, the main technical concern is sea recovery. It appears feasible, but there is not much data base. For the winged system there are concerns about launch and recovery siting because the booster is a down range lander and a suitable place to launch must have a down range recovery site. In addition, for the reference payload mass, the packaging density is considerably higher than for the ballistic vehicle and may present some problems with the low density components. The wing-wing vehicle also has a somewhat higher DDT&E cost. A shuttle growth vehicle using a liquid booster was selected for delivery of personnel to LEO with a cost per flight of \$12.6 million.

Orbit transfer options included a space-based and a ground-based OTV, and self-power ion propulsion. Self-power lessens transportation costs about 25%, is less sensitive to changes in LEO delivery cost and satellite mass and requires one-half as many launches. Self power of a thermal engine satellite was slightly cheaper than for annealable photovoltaics and presented fewer integration problems and potential collision with man made objects. The space based LO_2/LH_2 OTV showed 15% better performance than the ground based OTV. The space-based orbit transfer vehicle requires on-orbit propellant transfer but based on work done by General Dynamics, it appears possible to transfer the propellant without rotating a staging base. It may be sufficient merely to rotate the propellant by using electric pumps to withdraw the propellant and inject it into the OTV tanks in such a way that a rotation is set up within the tanks.

Critical commodity investigations on the LEO transportation system revealed only appreciable quantity compared to domestic production but none appear to be critical based on world production and reserve status. Tantalum may be a concern in the self-power electric propulsion option and although several substitutes are possible depending on the specific application.

PRECEDING PAGE BLANK NOT FILMED

FREIGHT LAUNCH OPTIONS

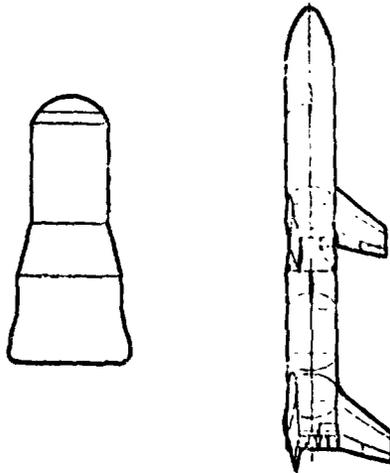

4

- PERFORMANCE AND COST PER FLIGHT ABOUT EQUAL, ≈ \$20/KG
- BALLISTIC CONCERN: SEA RECOVERY
- WING/WING CONCERNS:
 - PAYLOAD BAY DENSITY
 - LAUNCH & RECOVERY SITING
 - HIGHER DDT&E COST

ORBIT TRANSFER OPTIONS

CHEMICAL



SPACE BASED



GROUND BASED

ELECTRIC

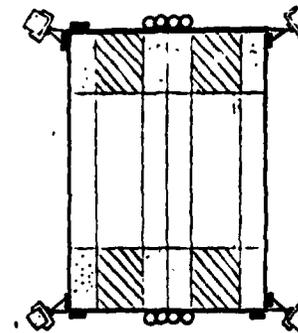

SELF POWER

- SELF-POWER REDUCES NET TRANSPORTATION COST ABOUT 25%
- SPACE-BASED CHEMICAL OTV ABOUT 15% BETTER PERFORMANCE
- SELF-POWER CONCERNS
 - RADIATION DEGRADATION
 - COMPLEXITY
 - COLLISION
- SPACE-BASED OTV CONCERN = PROPELLANT TRANSFER

D180-20689-5

Figure 2-1 Transportation Evaluation Summary

3.0 INTRODUCTION

Initial estimates of the Solar Power Satellite (SPS) system indicate that an operational power generating satellite will weigh about 100 million kilograms. The NASA/JSC Scenario 'B' identifies a 112 operational satellite total program with an annual installation rate varying between one and seven satellites per year. This demanding scenario will require hundreds of launches of a 400 metric ton payload capability launch vehicle for each satellite installation.

The issue of whether each satellite is constructed in low earth orbit (LEO) or geosynchronous earth orbit (GEO) impacts the LEO transportation system since the number of flights required for GEO construction is between a factor of 1.5 to 2.0 greater than for LEO construction. The economics of the LEO transportation significantly drives the overall satellite system installation cost.

The "LEO freighter" vehicle will transport the majority of the payloads between earth and low earth orbit and be specifically dedicated, designed, and developed for the SPS mission. Due to the high launch rates and the launch vehicle's impact on systems cost a number of design considerations become apparent. Some of these are:

- Vehicle design life
- Degree of reusability
- Vehicle operational mode and characteristics
- Resultant development and operational cost

Previous studies have indicated that elimination of any expendable hardware on the vehicle is desirable from an economic standpoint, particularly at the higher launch rates. The results from the "Systems Concepts for STS-Derived Heavy-Lift Launch Vehicle (HLLV) Study," Contract NAS9-14710, indicated for a 270 metric ton payload vehicle that expendable hardware (primarily the payload shroud) could amount to between 25% and 45% of the operating cost depending on payload density, as shown in Figure 3.0-1. A "design goal" in the definition of vehicle candidate concepts was to eliminate or minimize the amount of expendable hardware.

Section 5.0 describes two of the "LEO Freighter" concepts and also a personnel carrier which transports crews between earth and low earth orbit. The large payload capacity freighter candidates are both 2-stage series burn vehicles and include the ballistic recovery and winged recovery options. A derivative of the current Space Transportation System (STS) incorporating a recoverable liquid fueled booster rather than the Solid Rocket Boosters was the concept defined for the Personnel Carrier Vehicle. The three concepts are shown in Figure 3.0-2.

D180-20689-5

Section 6.0 describes the orbit transfer vehicles analyzed for the delivery of personnel, supplies and SPS cargo between LEO and GEO. Self power electric propulsion systems are analyzed for the delivery of the satellite when constructed in LEO. Chemical systems using LO₂/LH₂ transfer satellite components when construction is to be done in GEO. Chemical LO₂/LH₂ systems are used in all cases for the delivery of crews and base supplies.

2 - STAGE BALLISTIC RECOVERABLE

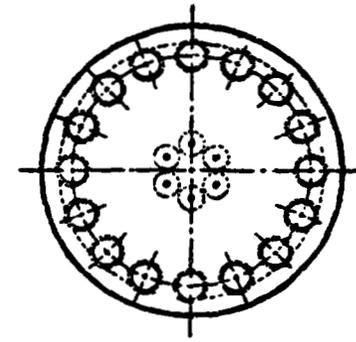
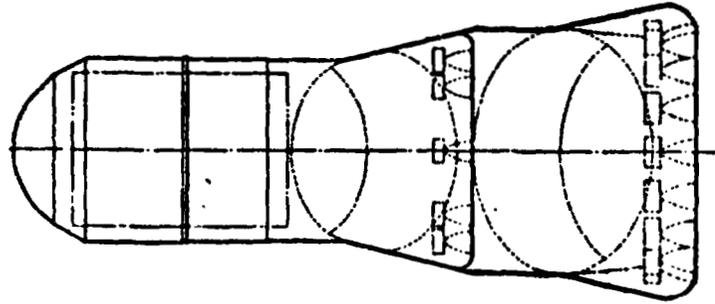

2 - STAGE WINGED RECOVERABLE

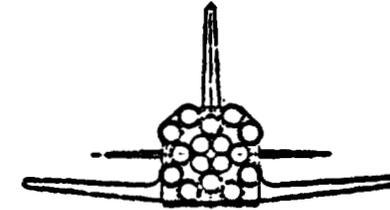
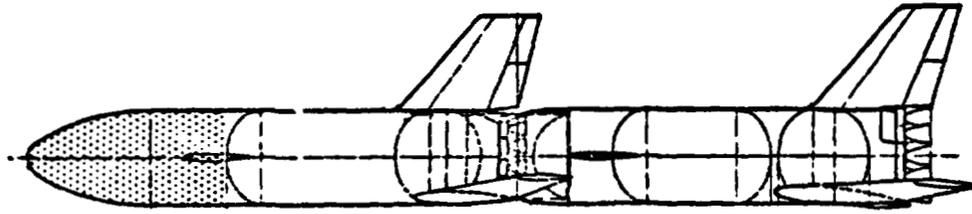

PERSONNEL CARRIER

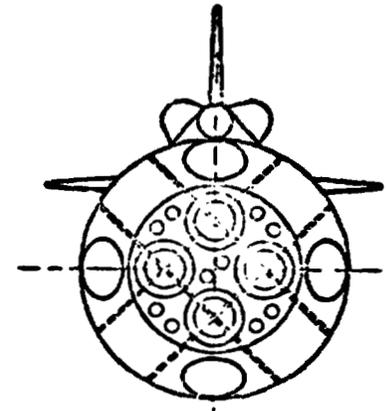
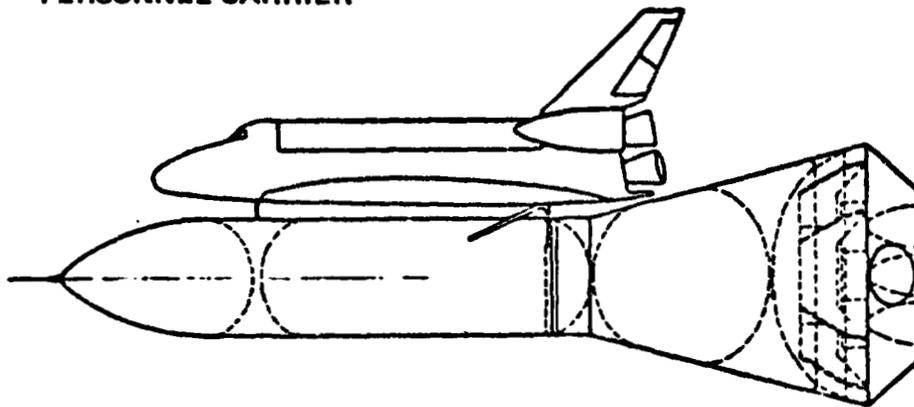

D180-20689-5

Figure 3 0-2 SPS Earth to LEO Transportation Concepts

4.0 MISSION REQUIREMENTS, GROUND RULES AND ASSUMPTIONS

The NASA/JSC SPS Scenario 'B' identified a 112 satellite installations in geosynchronous orbit with an annual installation rate of between 1 and 7 satellites per year. An equivalent program of 4 satellites a year over 28 years was selected for transportation system analysis. Recognizing that for a given vehicle system, which can be identified at this time, a 28 year period of operation that neglects technology advancements and potential improved versions would not appear logical. For purposes of amortizing fleet costs, a 14 year operational period was assumed and all costs reflect the program elements through the midpoint of the SPS implementation program.

A Kennedy Space Center launch site was assumed and a 477.5 km circular delivery orbit inclined at 31° inclination was selected. Since four satellites are being constructed simultaneously in the equivalent scenario, four orbits, all inclined at 31°, but spaced 90° apart, were selected as the delivery points. Two daily launch opportunities to each delivery orbit are available with the southerly opportunity about 3 1/3 hours after the northerly launch.

A vehicle net payload in the neighborhood of 400 metric tons was selected and based on a nominal satellite mass of 100,000 metric tons, an annual launch rate of 3125 and 1875 for GEO and LEO construction, respectively, for mass limited flights results. GEO construction location requires 12 launches a day based on using a 52 week per year, 5 day a week launch operations schedule. The corresponding rate to support LEO construction is a maximum of 8 launches daily.

Payload packaging density requirements can impose significant requirements on the launch vehicle in either design requirements and/or additional flights due to volume limitations. Since both propellant and satellite hardware are transported by the launch vehicle, a range of probable densities can be established. GEO construction requires twice as many propellant flights as compared to cargo (hardware) flights. The LO_2/H_2 propellant bulk density required for the chemical orbit transfer vehicle associated with GEO construction is approximately 340 kg/m^3 . The satellite hardware packaging density varies dependent on the type of power generation system. The photovoltaic type of system exhibits an average packaging density of about 30 kg/m^3 whereas the thermal engine system average packaging density is in the neighborhood of 75 kg/m^3 . Based on the above, an average packaging density requirement of less than 150 kg/m^3 was established for the large freighter type LEO launch vehicle.

The launch operations plan is based on a 5 day a week, three shift activity. The extra two day period each week will provide an opportunity to perform unscheduled equipment maintenance as required, and to achieve make-up launches as needed. It should be noted that the upper stage transports the payload to the final destination in the 477.5 km circular orbit. The upper stage remains on-orbit for one day and then is deorbited for an earth return. The key points of the requirements and assumptions are summarized in Figure 4.0-1.

SPS-283

Ground rules/requirements/assumptions

- **Equivalent JSC scenario “B”** **4 satellites/year for 28 years**

- **Delivery orbit** **477.5 km (circular) at 31° inclination**
- **KSC launch** **28.5° N. latitude**
- **Delivered payload** **≈ 400,000 kg (net)**
- **Cargo packaging density** **<150 kg/m³**

- **Nominal satellite mass** **100 x 10⁶kg**
- **Annual number of flights**
 - LEO assembly **1875**
 - GEO assembly **3125**

- **Assume 5-day, 52-week, three-shift launch operations**
- **Design goal: eliminate expendable hardware**

Figure 4.0-1 Launch Vehicle Preliminary Requirements

TABLE OF CONTENTS

		Page
5.1.1	Vehicle Geometry	15
5.1.2	Booster Stage	19
5.1.2.1	System Description	19
5.1.2.1.1	Ascent Propulsion	19
5.1.2.1.2	Structures	20
5.1.2.1.3	Thermal Protection	21
5.1.2.1.4	Landing and Auxiliary Systems	21
5.1.2.1.5	Other Subsystems	21
5.1.2.2	Booster Mass Characteristics	22
5.1.2.3	Booster Cost Estimates	22
5.1.3	Upper Stage	24
5.1.3.1	System Description	24
5.1.3.1.1	Ascent Propulsion	24
5.1.3.1.2	Structures	25
5.1.3.1.3	Thermal Protection System	26
5.1.3.1.4	Landing and Auxiliary Systems	26
5.1.3.1.5	Other Subsystems	26
5.1.3.2	Upper Stage Mass Characteristics	27
5.1.3.3	U_t per Stage Cost Estimates	29
5.1.4	Tanker/Cargo Shroud	43
5.1.4.1	System Description	43
5.1.4.2	Tanker/Cargo Shroud Mass Characteristics	45
5.1.4.3	Tanker/Cargo Shroud Cost Estimates	45
5.1.5	Vehicle Performance	53
5.1.6	Vehicle Operations	55
5.1.7	2-Stage Ballistic SPS Freighter Cost per Flight	60

5.0 CANDIDATE VEHICLE DESCRIPTIONS FOR LEO TRANSPORTATION

Two candidates of the SPS LEO freighter have been sized, defined and costed. These are the 2-stage ballistic recoverable option and the 2-stage winged vehicle. In addition, an updated STS Shuttle vehicle system will be used for crew rotation between earth and low earth orbit. The following sections will include system description, mass properties and cost analysis.

5.1 TWO STAGE BALLISTIC RECOVERABLE LEO FREIGHTER

The 2-stage series burn ballistic recoverable vehicle is a tandem arrangement which uses RP-1/LO₂/LH₂ engines on the booster and standard SSME's on the upper stage. Prior to developing the configuration concept the vehicle sizing trends were investigated to determine the optimum first and second stage combinations for a ballistic recoverable vehicle as shown in Figure 5.1-1. The lower curve shown on Figure 5.1-1, is the trend for the reference HLLV vehicle (Contract NAS 9-14710) first stage with variable upper stage characteristics. As noted the design point is approximately at 20% less payload than optimum. This nonoptimum condition was the result of the requirement in the HLLV study for a 20 kg/m³ payload density shroud which drove the upper stage to a larger diameter and therefore stage size. The upper curve shown on Figure 5.1-1, represents the payload impact of a larger booster stage and a variable size upper stage. The design point selected for SPS vehicle definition uses the same size upper stage as was used in the HLLV study and incorporates a larger booster.

Ballistic Recoverable Concept—The cargo version of the ballistic recoverable vehicle concept and the major characteristics are shown in Figure 5.1-2. Within the vehicle gross liftoff mass of 10472 metric tons the booster and upper stage propellant loads are 8243 and 1479 metric tons, respectively. The overall vehicle geometry is noted on the figure. A net payload packaging density of 75 kg/m³ is available through the use of a three section telescoping shroud. The shroud in the retracted position is shown for the upper stage reentry configuration.

The tanker version of the ballistic recoverable vehicle, shown Figure 5.1-3, is applicable to the SPS GEO construction option where about 2/3 of the required flights per satellite are transporting LO₂/LH₂ propellant for the Orbit Transfer Vehicles (OTV). The tanker propellant capacity of 400 metric tons is divided based on a 5.5:1 mixture ratio split.

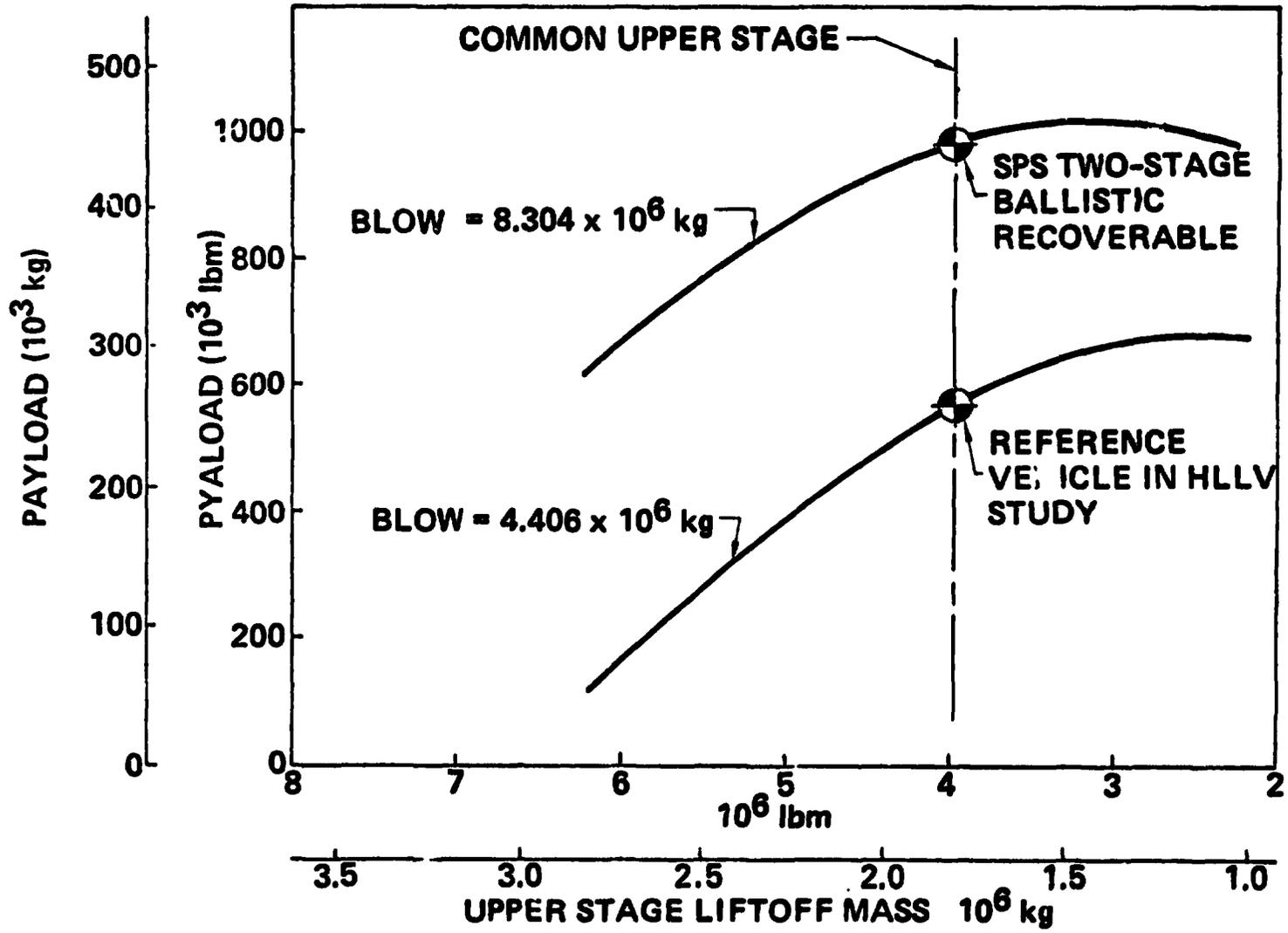
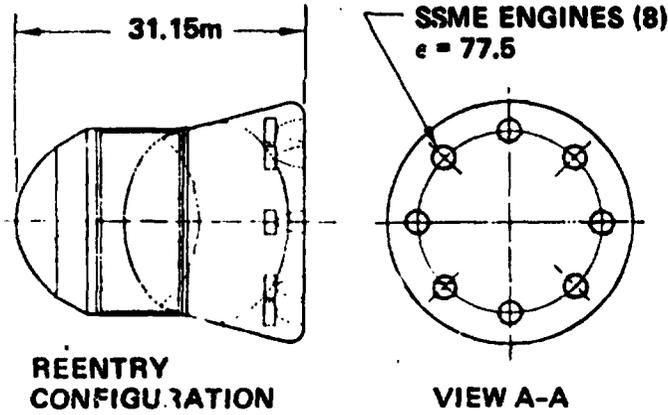

Figure 5.1-1 Vehicle Performance Trends

SPS-164



GLOW	10.472×10^6 kg	$(23.087 \times 10^6$ lbm)
BLOW	8.243×10^6 kg	$(18.173 \times 10^6$ lbm)
W_{P1}	7.456×10^6 kg	$(16.437 \times 10^6$ lbm)
ULOW	1.838×10^6 kg	$(4.051 \times 10^6$ lbm)
W_{P2}	1.479×10^6 kg	$(3.261 \times 10^6$ lbm)
PAYLOAD	0.391×10^6 kg	$(0.863 \times 10^6$ lbm)

T/W AT LIFTOFF 1.30

MAIN PROPULSION

STAGE	e	NUMBER/TYPER	THRUST/ENGINE (VACUUM)		EXHAUST VELOCITY		t_{sp} - SEC
			10^6 N	10^6 lbf	MPS	FPS	
1ST	42.5	16-LO ₂ /RP-1	9.060	2.037	3441	11290	360.7
2ND	77.5	8/STD SSME	2.001	0.470	4468	14660	456.2

VEHICLE CHARACTERISTICS

13

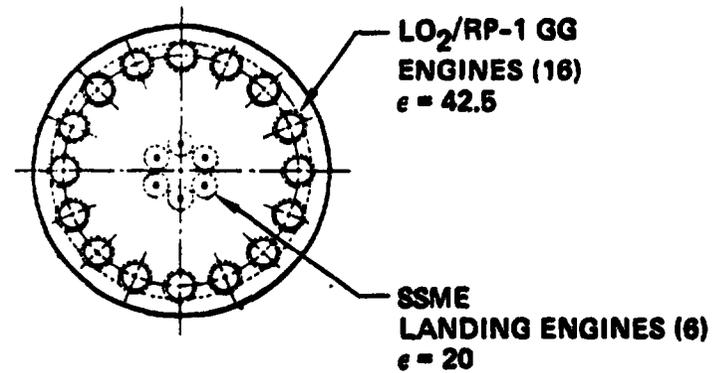
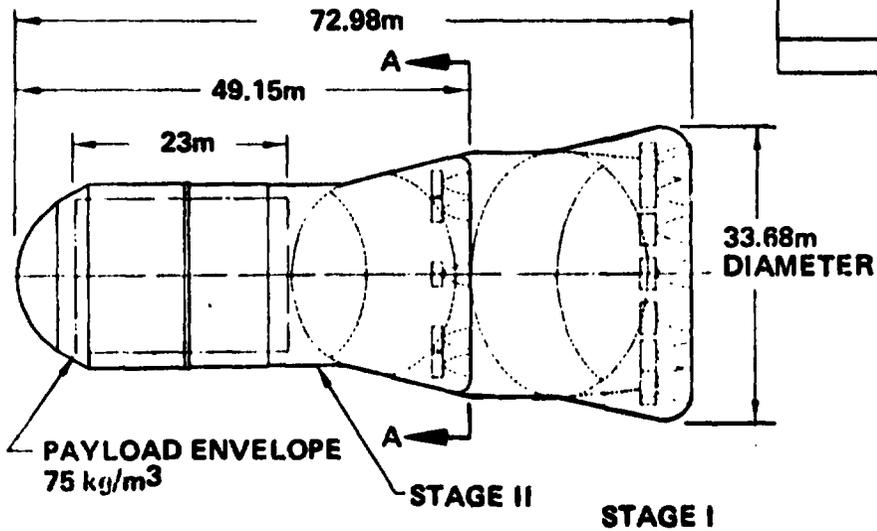

D180-20689-5

Figure 5.1-2 SPS Launch Vehicle-Cargo Version

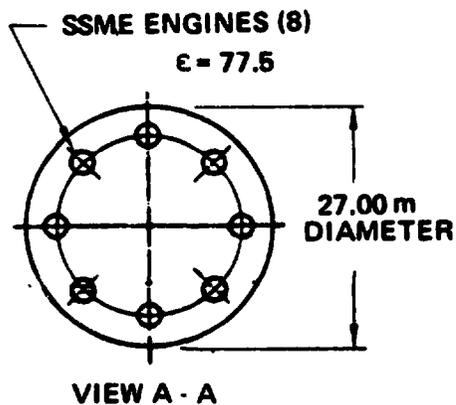

GLOW	10.464×10^6 kg	$(23.068 \times 10^6$ lbm)					
BLOW	8.303×10^6 kg	$(18.304 \times 10^6$ lbm)					
W_{P1}	7.456×10^6 kg	$(16.437 \times 10^6$ lbm)					
ULOW	1.756×10^6 kg	$(3.871 \times 10^6$ lbm)					
W_{P2}	1.457×10^6 kg	$(3.212 \times 10^6$ lbm)					
PAYLOAD	0.405×10^6 kg	$(0.893 \times 10^6$ lbm)					
T/W AT LIFTOFF 1.245							
MAIN PROPULSION							
STAGE	ϵ	NUMBER/TYPE	THRUST/ENGINE (VACUUM)		EXHAUST VELOCITY		t_{sp} - SEC
			10^6 N	10^6 lbf	MPS	FPS	
1ST	42.5	16-LO ₂ /RP-1	8.630	1.954	3441	11200	380.7
2ND	77.5	8/STD SSME	2.081	0.470	4488	14680	455.2

VEHICLE CHARACTERISTICS

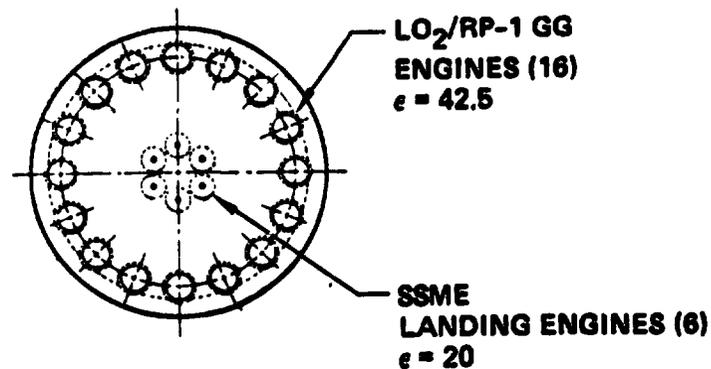
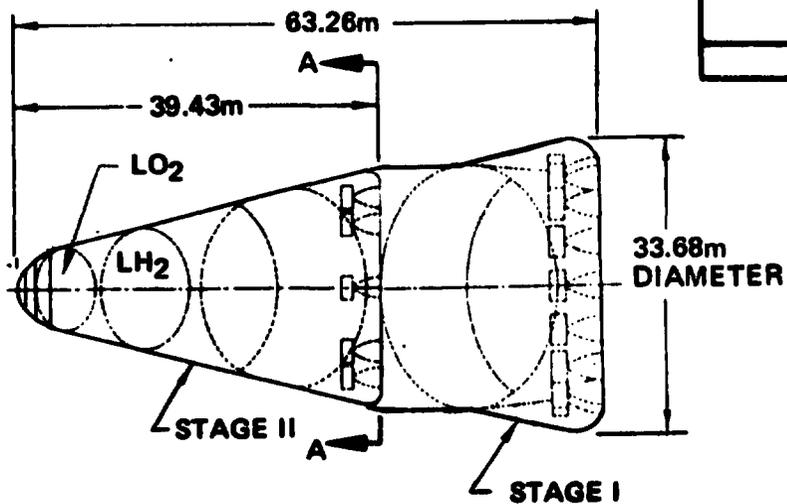

Figure 5.1-3 SPS Launch Vehicle-Tanker Version

D180-20689-5

5.1.1 Vehicle Geometry

The overall geometry for the 2-stage vehicle is shown in Figure 5.1.1-1. Both the cargo and tanker versions are shown on the drawing. All major body section locations are noted in the body station numbering system. The first stage is 33.68 meters (110.5 ft.) in diameter and 23.829 meters (78.2 ft.) in length. The sixteen main booster engines are mounted on a 25.6 meter (84.0 ft.) diameter. The six (6) SSME landing engines shown are mounted on a 6.1 meter (20.0 ft.) diameter. Since the gas generator engines require LH₂ cooling in addition to the main LO₂ and RP-1 propellants, the following tank volumes including ullage space are available:

$$V_{LO_2} = 5000 \text{ m}^3$$

$$V_{RP_1} = 2484 \text{ m}^3$$

$$V_{LH_2} = 1179 \text{ m}^3$$

The upper stage maximum diameter is about 27 meters (88.6 ft). The total length is dependent on whether the cargo or tanker payload version is considered. The cargo version in the ascent configuration is 49.15 meters in length and in the reentry configuration is 31.15 meters long due to the shroud retraction. Eight (8) standard SSME's are mounted in a ring pattern 20.1 meters (66 ft.) in diameter. The available tank volumes, including ullage, is 3270 m³ and 1209 m³ for the LH₂ and LO₂ tanks, respectively.

The LH₂/LO₂ tanker and cargo version sections interface with the upper stage at body station 39.194. The tanker section includes independent tanks for each propellant and maintains the conical side slope of the upper stage. The cargo section is cylindrical in cross-section capable of accommodating a 17 meter diameter by 23 meter in length payload package envelope which provides an average 75 kg/m³ packaging density.

FOLDOUT FRAME /

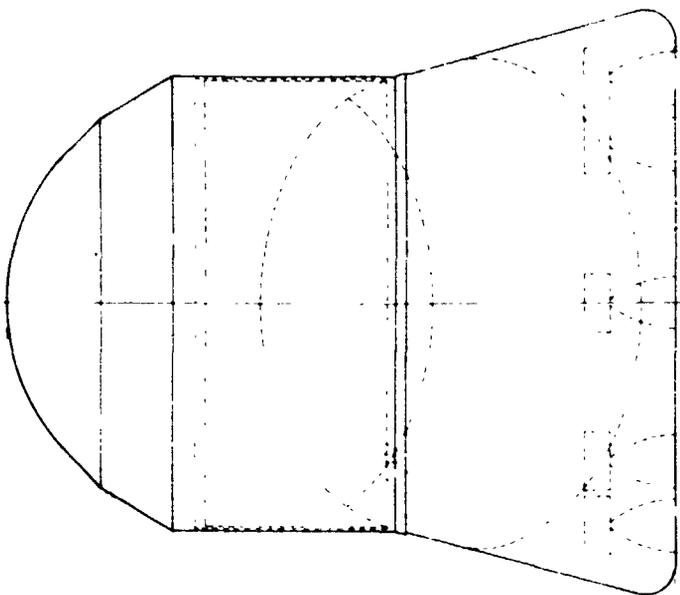

STA 21.425

**OPTIONAL SPS CARGO VERSION
RE-ENTRY CONFIGURATION**

STA 52.578

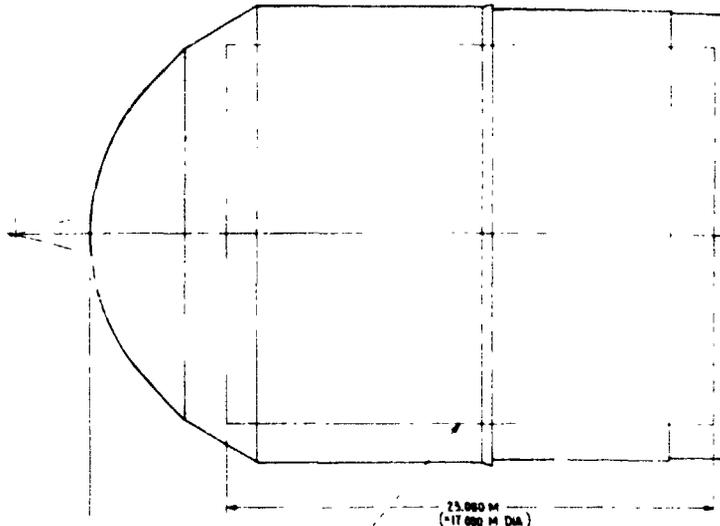

STA 3.429

TYPICAL PAYLOAD
PACKAGE ENVELOPE
75 kg/M³

**OPTIONAL SPS CARGO
ASCENT CONFIGUR**

**ORIGINAL PAGE IS
OF POOR QUALITY**

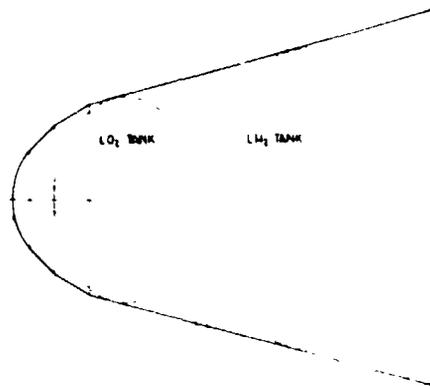

TRANSLAT POINT
EQUIVALENT

TRANSLAT POINT
EQUIVALENT

STA 0.000

STA 13.150

STA 18.378

STA 22.169

STA 26.991

STA 15.095

STA 17.791

STA 21.661

STA 26.127

STA 31.013

PRECEDING PAGE BLANK NOT FIT.

SPS LAUNCH VEHICLE

FOLDOUT FRAME 2.

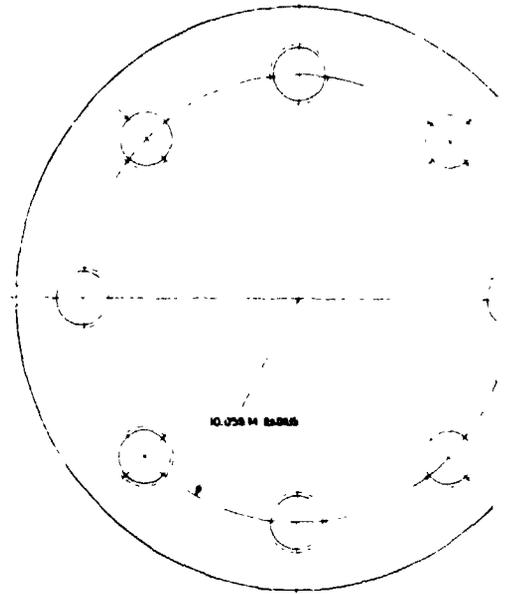
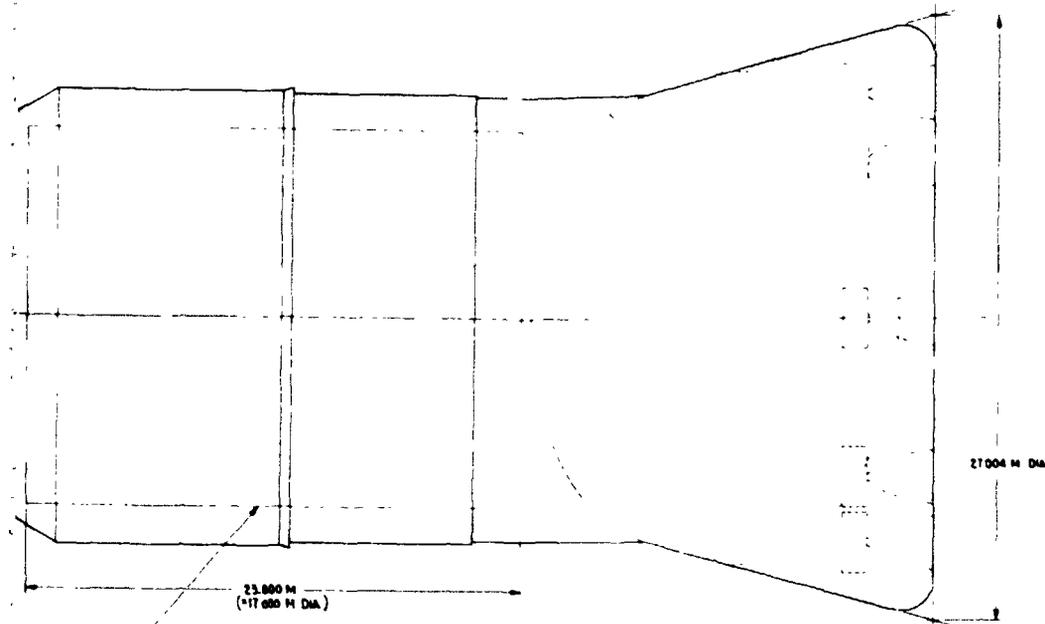

VIEW A-A

**OPTIONAL SPS CARGO VERSION
ASCENT CONFIGURATION**

STA 52.578

**ORIGINAL PAGE IS
OF POOR QUALITY**

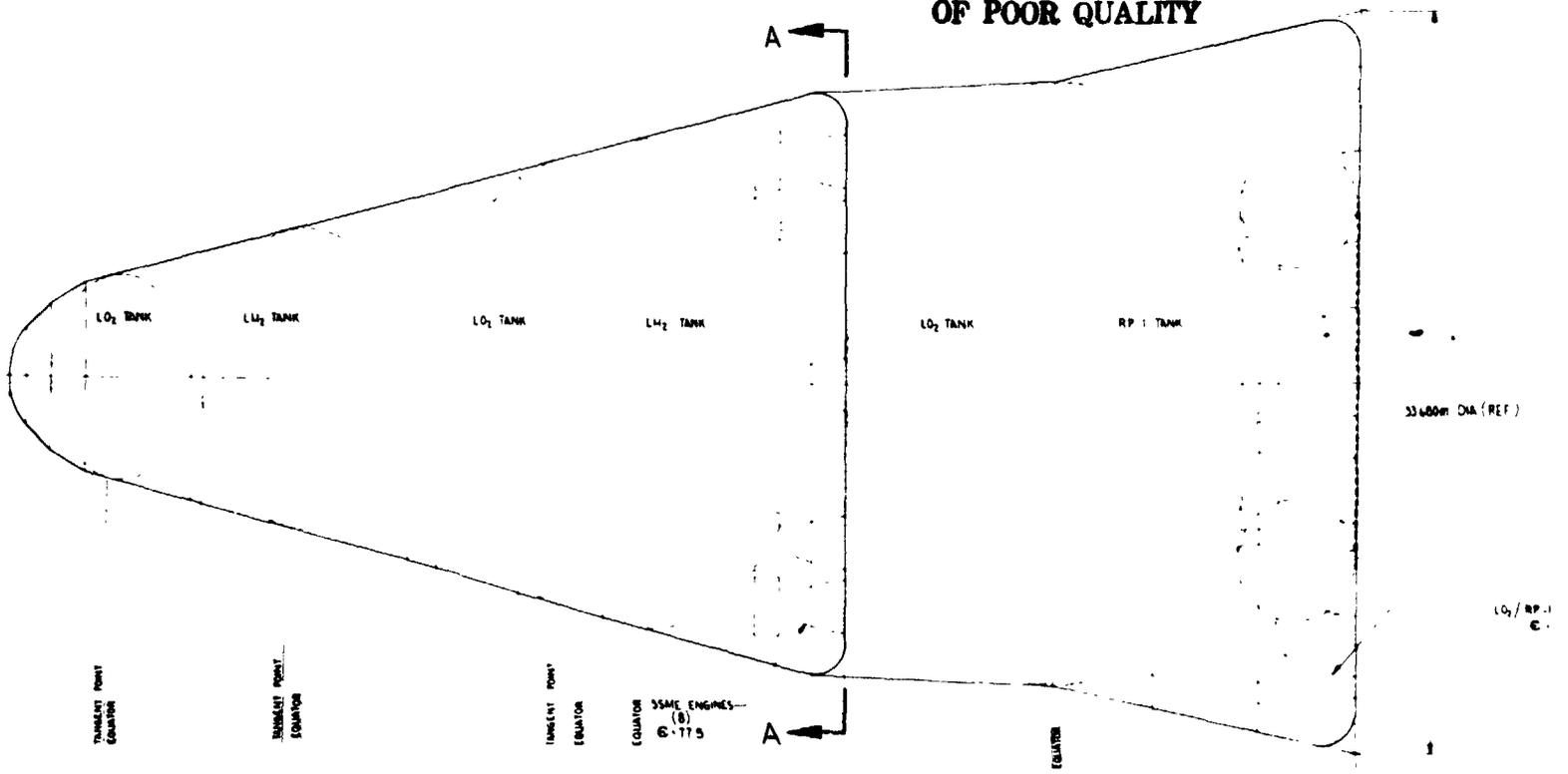

- STA 13.150
- STA 15.095
- STA 17.791
- STA 18.378
- STA 21.661
- STA 22.169
- STA 26.127
- STA 26.991
- STA 31.813
- STA 33.194
- STA 37.237
- STA 39.119
- STA 40.413
- STA 41.279
- STA 43.155
- STA 50.990
- STA 52.578
- STA 61.875
- STA 62.206
- STA 66.855
- STA 71.835
- STA 76.407

SPS LAUNCH VEHICLE TANKER VERSION LIFT-OFF CONFIGURATION

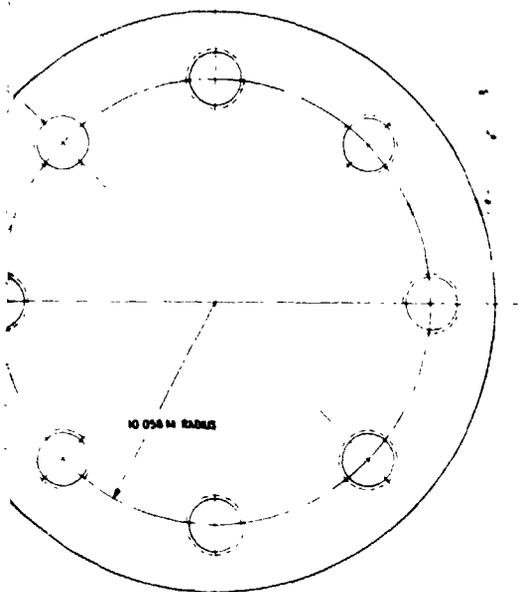

VIEW A-A

VEHICLE CHARACTERISTICS

- GLOW 10.464 · 10³ kg (23.068 · 10³ lbm)
- BLOW 8.303 · 10³ kg (18.304 · 10³ lbm)
- ULOW 1.756 · 10³ kg (3.871 · 10³ lbm)
- PARLOAD 0.405 · 10³ kg (0.893 · 10³ lbm)
- $\frac{1}{W}$ @ Lift-off 1 245
- MAIN PROPULSION

STAGE	C	NUMBER / TYPE	THRUST / ENGINE		EXHAUST VELOCITY		I _{sp} - sec
			10 ³ N	10 ³ Lb	MPS	FPS	
1 st	42	56 LO ₂ /RP-1	8.630	1.934	3441	11290	350.7
2 nd	177.5	8 / STD 5500E	2.021	0.470	4468	14660	453.2

**IS
ITY**

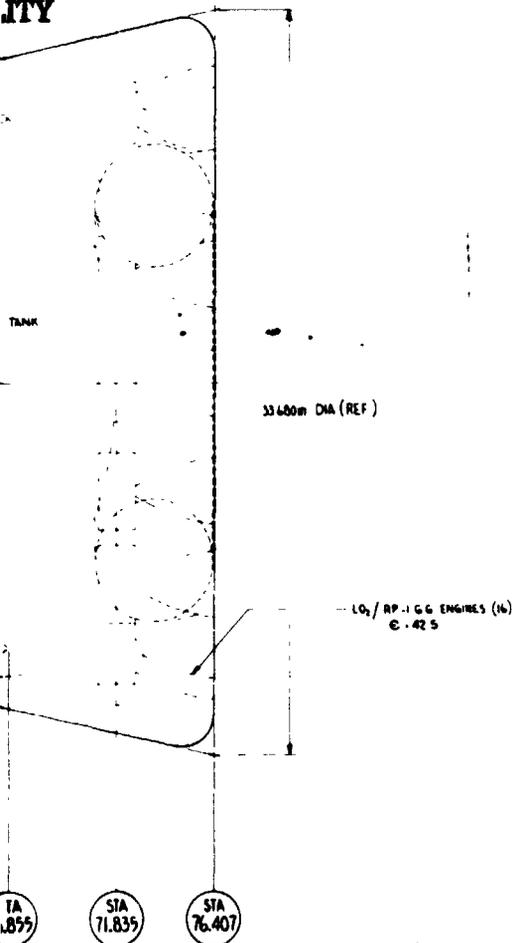

LH₂ TANK

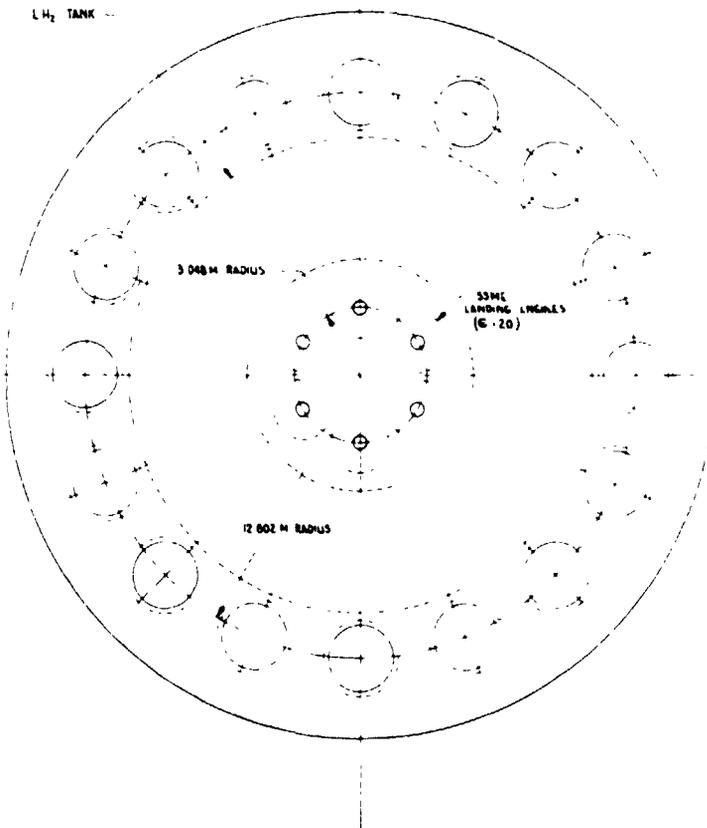

Figure 5.1.1-1 2-Stage Ballistic Recoverable Vehicle Configuration

5.1.2 Booster Stage

5.1.2.1 System Description

The booster stage of the 2 stage ballistic recoverable vehicle consists of the following subsystems:

- Ascent Propulsion
- Structures
- Thermal Protection
- Landing and Auxiliary Systems
- Auxiliary Propulsion
- Prime Power
- Electrical Conversion and Distribution
- Hydraulic Conversion and Distribution
- Avionics
- Environmental Control

Each of the subsystems will be discussed in the following sections including definition of the rationale for the mass and cost estimates.

5.1.2.1.1 Ascent Propulsion—The ascent propulsion subsystem consists of the main engines, accessories, gimbals, and fuel and oxidizer systems. Main propulsion is provided by sixteen RP-1/LO₂ gas generator cycle engines which use liquid hydrogen (LH₂) for engine cooling and the associated pressurization system and propellant delivery. The engine is a scaled up version of the Alternate Mode 1 engine defined by Aerojet Liquid Rocket Company under contract to NASA Lewis Research Center. The following engine characteristics were used in the analysis:

Propellants	RP-1/LO ₂ /LH ₂	
Thrust - Vacuum	9.059 x 10 ⁶ N	(2.037 x 10 ⁶ lbf)
Chamber Pressure	29300 kpa	(4250 psia)
Mixture Ratio	2.9:1	
Specific Impulse (SL/Vac.)	323.5/350.7 sec.	
Total Flow Rate/Engine	2635 kg/sec	(5808 lbfm/sec)

Engine overall length is 5.44m and the powerhead and exit diameters are 3.51 m and 2.97 m, respectively. The total engine mass including accessories is estimated to be 138322 kg.

The pressurization gases are heated GO₂ for the LO₂ tank and heated GH₂ for the RP-1 tank. Individual propellant delivery lines are provided to each engine. The total mass of the propellant system is 39431 kg. Historical weight estimating relationships (WER's) were used to determine the mass of the ascent propulsion subsystem.

5.1.2.1.2 Structures—The structures subsystem consists of the forward skirt, LO₂ tank, RP-1 tank, LH₂ tank, aft skirt, thrust structure, base and secondary structure. A preliminary sizing analysis was conducted to determine the structural element masses.

Forward Skirt—The forward skirt experiences its maximum compressive load during the boost maximum acceleration condition. The magnitude of the peak compressive load is 18200 N/cm. The material selected is 5A1-4V titanium (beta processed).

A body shell average thickness, including smeared stiffeners, of 0.53 cm is required to satisfy the load conditions. The estimated total mass of the forward skirt is 10710 kg.

LO₂ Tank—An all welded 2219-T87 aluminum design concept has been selected for the LO₂ tank. A maximum operating pressure of 326 kpa is anticipated. Peak proof test pressure of 434 kpa will provide adequate service life and is the pressure vessel design requirement. Resultant membrane thickness varies between 0.80 cm and 0.99 cm. The total mass of the LO₂ tank is 38 208 kg.

RP-1 Tank—The RP-1 tank, including the common bulkhead is also a welded 2219-T87 aluminum pressure vessel. The upper dome, which is common with the LO₂ tank, is stiffened to provide the negative pressure capability. A maximum operating pressure of 256 kpa is anticipated. A corresponding peak proof pressure of 341 kpa will provide adequate service life. The lower dome membrane thickness varies 0.67 cm and 0.99 cm. The stiffened common dome has a smeared equivalent thickness of approximately 1.5 cm. The total mass of the RP-1 tank is 37 437 kg.

LH₂ Tank—The LH₂ tank is a toroidal pressure vessel fabricated from 2219-T87 aluminum alloy and insulated with a foam type thermal protection system. The maximum anticipated operating pressure is 172 kpa and the corresponding required proof pressure is 230 kpa. The total mass of the LH₂ tank is 6205 kg.

Aft Skirt—The aft skirt is a 6A1-4V titanium structure, conical in shape, which provides vehicle support prior to launch and also distributes the landing loads into the body. The magnitude of the compressive load varies between 12500 N/cm and 17300 N/cm. A smeared skin thickness of between 0.38 cm and 0.52 cm is required. The total mass of 59745 kg includes the body shell, frames and local support structure.

D180-20689-5

Thrust Structure--The 16.0 m long thrust structure is conical in shape and supports the main engines. The materials used include 6Al-4V titanium and graphite epoxy composites. A thrust post at each engine location introduces the concentrated load into the conical shell. A major frame at the aft end distributes the engine lateral loads. A peak compressive loading of 25900 N/cm is anticipated for the maximum acceleration condition. The average smeared skin thickness is 0.75 cm. The total mass of the thrust structure is 63620 kg.

Base Structure--The 6Al-4V titanium base skirt panels are sized considering the ascent, reentry and landing base pressures. The anticipated maximum pressure is 57.5 kpa for the conditions considered. The panels are actively cooled with water during the ascent and entry portions of the flight. A graphite composite tubular truss arrangement supports the panels and distributes the loads to the aft skirt and thrust structure. The total mass is 52313 kg.

Secondary Structure--The secondary structure consists of primarily of the main engine closure doors, landing system support structure and other secondary elements. The estimated total mass for the secondary structure is 15415 kg.

5.1.2.1.3 Thermal Protection--The thermal protection system includes the coolant (water), storage vessels, distribution and ducting system. The mass estimates were determined from previous analysis conducted on other studies. In addition, LH₂ tank foam insulation is included. The total thermal protection subsystem mass is estimated at 44470 kg.

5.1.2.1.4 Landing and Auxiliary System--The landing system consists of six (6) modified SSME's ($\epsilon = 20$) which provide stage terminal deceleration prior to water landing. The landing engines and their associated components including engine accessories, propellant delivery, pressurization, and propellant tanks have a dry mass of 28143 kg. The separation system mass has been estimated at 2336 kg which will result in a total mass for this category of 30479 kg. A potential alternate landing system that warrants investigation in the future is a throttlable pressure-fed system.

5.1.2.1.5 Other Subsystems--The remaining subsystem masses have been estimated using historical or shuttle predicted weights. These subsystems include auxiliary propulsion (RCS), prime power, electric conversion and distribution, hydraulic conversion and distribution, avionics, and environmental control.

Auxiliary Propulsion--The reaction control system (RCS) is required for stage orientation prior to entry and control during entry. The subsystem dry mass is 1489 kg.

Prime Power--The major electrical power sources on the booster are both batteries and auxiliary power units. The prime power subsystem mass is estimated to be 735 kg.

D180-20689-5

Electric Conversion and Distribution—The power conditioning and cabling elements are included in this category. The estimated mass is 3316 kg.

Hydraulic Conversion and Distribution—The hydraulic system for the thrust vector control and actuation systems (such as the engine closure doors) is included in this category. The estimated mass for this function is 9874 kg.

Avionics—Avionics subsystem includes the guidance and navigation, data management, and the communication system elements. The total mass of the avionics subsystem is estimated to be 2431 kg.

Environmental Control—The onboard environmental control system is primarily associated with the thermal conditioning of the avionics equipment and the purge requirements for the main engines after shutdown. The subsystem mass is estimated to be 5220 kg.

5.1.2.2 Booster Mass Characteristics

The booster mass characteristics reflect the results of the preliminary structural sizing analysis and the incorporation of historical weight estimating relationships. Element masses have been identified and described in Section 5.1.2.1, System Description. The summarized mass statement for the booster is shown in Table 5.1.2-1. A 10% mass growth allowance has been included on all the dry mass elements. The total booster stage dry mass is estimated at 615362 kg.

The fluids inventory is noted on Table 5.1.2-1. Residual and unusable fluids and gases are the major inert mass item in the fluid inventory. The residual mass reflects the typical LO₂/hydrocarbon propellant values consistent with a booster stage that doesn't include a closed loop propellant utilization system.

The retro propellant required for the landing system was estimated to provide a nominal zero terminal velocity with adequate margins. A reserve landing propellant allowance of slightly greater than 15% has been included in the fluids inventory.

5.1.2.3 Booster Cost Estimates

The booster DDT&E and first unit production costs have been estimated at the vehicle level and are reported in Section 5.1.3.3 along with the upper stage costs.

Table 5.1.2-1 Booster Mass Statement Summary

SPS-2R4

Stage element	10 ³ kg	10 ³ lbm
Structure	283.65	625.34
Thermal protection system	44.47	98.04
Main propulsion	177.75	391.88
Auxiliary propulsion, RCS	1.49	3.28
Landing and auxiliary system	30.48	67.19
Prime power	0.74	1.62
Electric conversion and distribution	3.32	7.31
Hydraulic conversion and distribution	9.81	21.77
Avionics	2.43	5.36
Environmental control system	5.22	11.51
Mass growth (10%)	<u>55.94</u>	<u>123.33</u>
Dry mass (including H ₂ O for TPS)	615.36	1,356.63
Residual and unusable propellant	117.81	259.72
Reserve retro propellant	6.97	15.37
Usable RCS propellant	3.15	6.94
Usable retro propellant	<u>44.40</u>	<u>97.87</u>
Total inert	787.69	1,736.53
Ascent propellant	<u>7 455.70</u>	<u>16,436.84</u>
BLOW	8,243.39	18,173.37

23

D180-20689-5

5.1.3 Upper Stage

5.1.3.1 System Description

The upper stage of the 2 stage ballistic recoverable vehicle consists of the following subsystems:

- Ascent Propulsion
- Structure
- Thermal Protection
- Auxiliary Systems
- Auxiliary Propulsion
- Prime Power
- Electric Conversion and Distribution
- Hydraulic Conversion and Distribution
- Avionics
- Environmental Control

Each of the subsystems will be discussed in the following sections including definition of the rationale for the mass and cost estimates.

5.1.3.1.1 Ascent Propulsion—The ascent propulsion subsystem consists of the main engines, accessories, gimbal and the fuel and oxidizer systems. Main propulsion is provided by eight (8) standard SSME's ($\epsilon = 77.5$). The following engine characteristics were used in this analysis:

Propellants	LH ₂ /LO ₂	
Thrust - Vacuum	2.090 x 10 ⁶ N	(470,000 lbf)
Chamber Pressure	20685 kpa	(3000 psia)
Mixture Ratio	6:1	
Specific Impulse - (SL/vac)	363.2/455.2 sec	
Total Flow rate/Engine	468.4 kg/sec	(1032.5 lbm/sec)

Engine overall length is 4.24 m and the maximum powerhead dimension and exit diameter is 2.67 m and 2.39 m respectively. The total main engine mass including accessories, etc. is estimated to be 25815 kg.

The pressurization gases are heated GH₂ and GO₂ for the main tanks. Individual propellant delivery lines are provided to each engine. Tunnels are provided in the LO₂ tank for the LH₂ delivery lines. These tunnels protect the LH₂ lines from the overpressure in the LO₂ tank and provide a secondary seal against potential hazardous leaks. The total mass of the propellant system is 4039 kg. Historical weight estimating relationships were used to determine the mass of the ascent propulsion system.

D180-20689-5

5.1.3.1.2 Structures—The structures subsystem consists of the LO₂ tank, LH₂ tank, aft skirt, thrust structure, base structure and secondary structure. A preliminary structural analysis was conducted to determine the structural element masses.

LO₂ Tank—An all welded 2219-T87 aluminum design concept has been selected for the LO₂ tank. Due to the maximum acceleration condition during boost a peak design pressure of 661 kpa is expected. A maximum proof test pressure of 880 kpa will provide adequate service life. The resultant maximum membrane thickness is 1.68 cm for the upper dome and a smeared thickness of 2.29 cm for the lower dome. The total LO₂ tank mass is 43746 kg.

LH₂ Tank—The LH₂ tank shares an upper common bulkhead with the LO₂ tank and contains a conical section and elliptical lower dome. A peak tank design pressure of 196.5 kpa is anticipated during flight. An incremental proof test with a maximum pressure of 261 kpa in the first part and 227 kpa in the second part will assure the service life requirements. The average smeared conical sidewall thickness, including stiffeners, is 0.85 cm. The membrane thickness tapers between 0.44 cm and 0.61 cm on the lower dome. The total mass of the LH₂ tank is 21806 kg.

Aft Skirt—The aft skirt is a 6Al-4V titanium structure, conical in shape, which interfaces with the forward skirt of the booster. The magnitude of the compressive load varies between 17660 N/cm and 21520 N/cm. A smeared skin thickness 0.43 cm and 0.52 cm is required. The total mass of 50689 kg includes the body shell, frames, and local support structure.

Thrust Structure—The 5.18 m long thrust structure is conical in shape and provides the mounting structure for the eight (8) SSME's at a diameter of 20.12 m. The materials incorporated include 6Al-4V titanium and graphite/epoxy composites. A thrust post, at each engine location, introduces the engine concentrated load into the shell. The major frame at the aft end of the cone distributes the engine lateral loads into the shell structure. A peak compressive load of 7200 N/cm is anticipated for the upper stage's maximum acceleration condition. The average required smeared skin thickness is 0.22 cm and the total mass of the thrust structure is 4726 kg.

Base Structure—The 6Al-4V titanium base skirt panels are sized considering the ascent, reentry and landing base pressures. The anticipated peak pressure is 47.9 kpa for the conditions investigated. The panels are actively cooled with water during the ascent and entry portions of the flight. The panel support structure is a graphite composite tubular truss arrangement that distributes the panel loads into the aft skirt and thrust structure. The mass of the base skirt structure is 24035 kg.

Secondary Structure—The secondary structure consists of all the supporting structure required for equipment, pressurization bottles, water coolant vessels, etc. The total mass is estimated at 7931 kg mass.

5.1.3.1.3 Thermal Protection System (TPS)—The thermal protection system consists of both the low and high temperature systems. The low temperature TPS for the LH₂ tank is a reusable internal foam system. A total mass of 3293 kg for the low temperature TPS was estimated based on historical data.

The high temperature TPS consists of the coolant (H₂O), storage vessels, distribution and ducting system for the base cooling during entry. The heat shield panels are included in the base structure mass of the structural subsystem. A mass of 15025 kg is estimated for the high temperature TPS (including the water coolant) and therefore the total TPS mass is predicted to be 18318 kg.

5.1.3.1.4 Landing and Auxiliary Systems—The landing system consists of using the eight on-board main propulsion units which will be reignited to provide terminal deceleration prior to water landing. Auxiliary systems, including closure doors, mechanisms and separation systems has been estimated to be 3747 kg.

5.1.3.1.5 Other Subsystems—The remaining stage subsystems have been estimated using historical or Shuttle predicted masses. These subsystems include auxiliary propulsion, prime power, electric conversion and distribution, hydraulic conversion and distribution, avionics, and environmental control.

Auxiliary Propulsion—The auxiliary propulsion system consists of the orbit maneuvering (OMS) and reaction control systems (RCS). The OMS consists of two (2) RL-10 engines and associated pressurization, delivery and propellant storage (tankage) elements. A total dry mass of 1710 kg is estimated for the orbit maneuvering system.

The reaction control system consists of four sets of thrusters (4/set) and the associated pressurization, delivery and propellant storage hardware. Modified Shuttle hardware is proposed for the RCS system and the estimated mass is 3438 kg. A total auxiliary propulsion system mass of 5148 kg includes both the RCS and OMS elements.

Prime Power—The major electrical power sources on the upper stage are both fuel cells and auxiliary power units. The total prime power subsystem mass is estimated to be 476 kg.

Electric Conversion and Distribution—The stage power conditioning and cabling elements are included in this category. The estimated mass is 680 kg.

Hydraulic Conversion and Distribution—The hydraulic system for the thrust vector control and actuation system is included in this category. The stage hydraulic system also must provide services to the payload shroud in addition to all the stage functions. A mass of 3591 kg is estimated for this category.

D180-20689-5

Avionics—Guidance and navigation, data management and the communication system elements comprise the major portion of the avionics subsystem. The total mass of the avionics subsystem is estimated to be 1588 kg.

Environmental Control—The on-board environmental control system is primarily associated with the thermal conditioning of the avionics equipment and the engine purge functions. The subsystem mass is estimated to be 2073 kg.

5.1.3.2 Upper Stage Mass Characteristics

The upper stage mass characteristics reflect the results of the preliminary structural sizing, the incorporation of historical weight estimating relationships, and analyzing the stage sequence for orbital, reentry and landing maneuvers to establish the fluids inventory. Element masses have been identified and described in Section 5.1.3.1, System Description. The summarized mass statement, shown in Table 5.1.3-1, includes a dry mass breakdown and the second stage sequence with the mass noted after each event. The cargo shroud mass noted on the dry mass portion of the table is discussed in Section 5.1.4.2. The mass growth allowance has been divided into three categories and they include:

- 10% on all new developments
- 5% on modifications of existing hardware
- 0% on off the shelf hardware such as SSME's

The second stage sequence includes the fluids inventory for the major events from main engine cut-off (MECO) through landing. The upper stage propellant residuals were estimated considering a closed loop propellant utilization system. Reserves are included in the landing mass of 280 metric tons.

Table 5.1.3-1 2-Stage Ballistic Vehicle Upper Second Stage Mass Statement

28

DRY MASS	
STAGE ELEMENT	10 ³ kg
STRUCTURE	155.43
THERMAL PROTECTION SYSTEM	3.30
MAIN PROPULSION	29.85
AUXILIARY PROPULSION	5.15
PRIME POWER	0.48
ELECTRIC CONVERSION AND DISTRIBUTION	0.66
HYDRAULIC CONVERSION AND DISTRIBUTION	3.59
AVIONICS	1.59
ENVIRONMENTAL CONTROL SYSTEM	2.07
CARGO SHROUD	33.01
PAYLOAD SUPPORT SYSTEM	1.27
GROWTH	22.40
	<hr/>
DRY MASS	258.82

SECOND STAGE SEQUENCE	
EVENT	MASS AFTER EVENT
	10 ³ kg
STAGE AT MECO	749.58
ΔV RESERVES	736.63
APOGEE CIRCULARIZATION (OMS BURN)	719.11
RCS TRIM BURN	714.76
OMS TRIM BURN	713.05
DEPLOY PAYLOAD (MASS = 391,450 kg)	321.60
DEORBIT ΔV	313.14
H ₂ O EXPENDED DURING ENTRY	301.12
LANDING RETRO	279.85
	<hr/>
MASS AT LANDING	279.85
RESIDUALS AND UNUSABLES	14.28
RESERVES, LANDING PROPELLANT AND H₂O	6.75
	<hr/>
DRY MASS	258.82

D180-20689-5

5.1.3.3 Upper Stage Cost Estimates

The 2-stage ballistic recoverable vehicle's upper stage and booster DDT&E and first unit production costs are discussed in this section. The Boeing Parametric Cost Model (PCM) has been used in developing these estimates. PCM includes a complete set of cost estimating relationships (CER's) derived from historical data and include both direct relationships and composite relationships. The cost model has been used on many previous studies and is periodically updated to provide latest data base. The PCM allows a number of input options including "thru-put" costs for elements such as SSME's, RL-10's, etc.

The basic work breakdown structure (WBS) for DDT&E and production costs is shown in Figure 5.1.3-1. Program Management has been estimated as a 10% factor on the manhours required and Flight Test operations has been included as rough order of magnitude ("ROM") value.

The DDT&E and 1st unit production costs for the 2 stage ballistic recoverable vehicle are shown in Table 5.1.3-2. Since both the booster and upper stage elements are included, entries number 4 thru 52 are the upper stage cost elements and entries 54 thru 93 are the booster cost elements. The \$108M Flight Test Operations entry (#53) is applicable to the total vehicle.

Direct cost estimates (thru-puts) have been used for the following cost elements:

	DDT&E	1st Unit
SSME	\$32.5M	\$12.4M TFU/engine
RL-10	\$10.8M	\$ 0.757M TFU/engine

The tooling cost entry for DDT&E includes tool design and the fabrication of a single shipset of production tooling.

A DDT&E cost of slightly more than \$7.1B and a 1st unit cost of \$895.8M are estimated for both the stages. The DDT&E estimate includes the equivalent of 2.5 ground test and 2.0 flight test units.

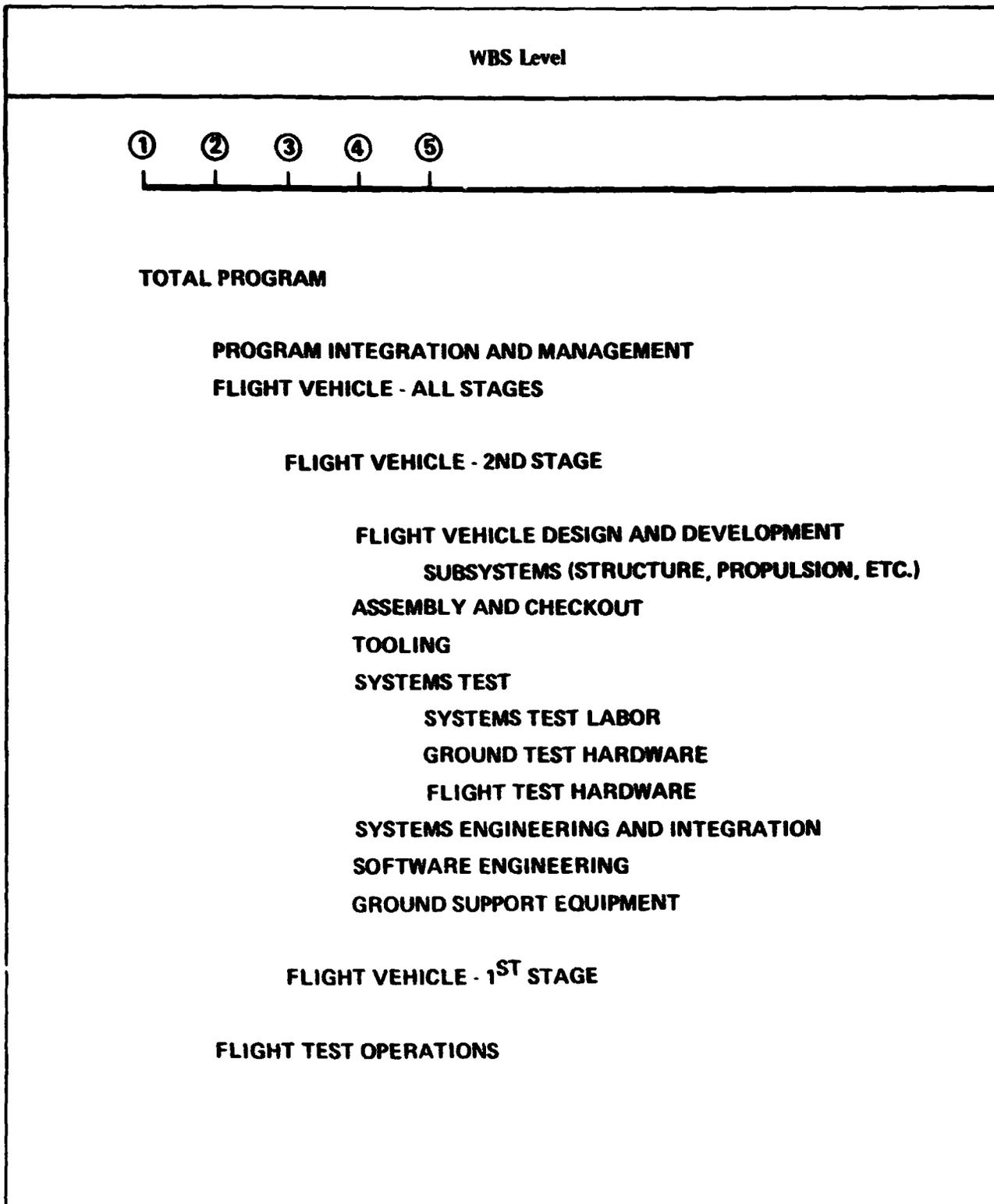

Figure 5.1.3-1 Stage Work Breakdown Structure

Table 5.1.3-2 2-Stage Ballistic Recoverable Vehicle DDT&E and First Unit Cost

NO	NAME	SUB TO	ELEMENT	METHOD	SOUR- CES	BLEND FACTORS	SUPT FROM	OTS %	MOD %	MOD CMLX	NUMBER	LRN %	COST (000)
1	TOTAL PROGRAM	0	DDT&E	SUBS	0	0.00	0	0	0	0.0			7,111,598
			UNIT	SUBS	0	0.00	0				0	0	895,843
2	PROG INTER & MANAG	1	DDT&E	FACTOR	3	0.10	0	0	0	0.0			283,653
			UNIT	FACTOR	3	0.10	0				0	0	61,313
3	FLT VEH ALL STAG	1	DDT&E	SUBS	0	0.00	0	0	0	0.0			6,719,946
			UNIT	SUBS	0	0.00	0				0	0	834,530
4	FLT VEH 2ND STAGE	3	DDT&E	SUBS	0	0.00	0	0	0	0.0			2,106,463
			UNIT	SUBS	0	0.00	0				0	0	282,900
5	FLT VEH D&D	4	DDT&E	SUBS	0	0.00	0	0	0	0.0			545,205
			UNIT	SUBS	0	0.00	0				0	0	249,497
6	STRUCTURE	5	DDT&E	SUBS	0	0.00	0	0	0	0.0			228,612
			UNIT	SUBS	0	0.00	0				0	0	80,724
7	LO2 TANK 106090 LBS	6	DDT&E	CER	62	1.00	28	0	0	0.0			52,341
			UNIT	CER	63	1.00	54				1	85	16,418
8	LH2 TANK 52881 LBS	6	DDT&E	CER	62	1.00	28	0	0	0.0			28,172
			UNIT	CER	63	1.00	54				1	85	9,052

31

D180-20689-5

ORIGINAL PAGE IS
OF POOR QUALITY

Table 5.1.3-2 (Continued)

9 APT SKIPT 122924 LBS	6 DDT&E CER	3	1.00	28	0	0	0.0		83,015
	UNIT CER	37	1.00	54				1 85	30,826
10 THRUST STRUCTURE 11461 LBS	6 DDT&E CER	3	1.00	28	0	0	0.0		10,120
	UNIT CER	37	1.00	54				1 85	3,850
11 BASE STRUCTURE 77519 LBS	6 DDT&E CER	3	1.00	28	0	0	0.0		54,962
	UNIT CER	37	1.00	54				1 85	20,576
12 TPS 14535 SQP	5 DDT&E CER	64	1.00	28	0	0	0.0		16,702
	UNIT CER	65	1.00	54				1 85	8,197
13 LANDING SYS 6063 LBS	5 DDT&E CER	5	1.00	28	0	0	0.0		91,938
	UNIT CER	3	1.00	54				1 85	2,203
14 PROP ASCENT	5 DDT&E SUBS	0	0.00	0	0	0	0.0		64,745
	UNIT SUBS	0	0.00	0				0 0	85,133
15 SSME'S	14 DDT&E \$	0	0.00	0	0	0	0.0		32,500
	UNIT \$	0	0.00	0				8 90	81,571
16 SSME ACCES 812 LBS	14 DDT&E CER	5	1.00	28	0	0	0.0		15,266
	UNIT CER	40	1.00	54				8 90	1,767

32

D180-20689-5

ORIGINAL PAGE IS
OF POOR QUALITY

Table 5.1.3-2 (Continued)

17 PROP DELIVERY 6928 LBS	14 DDT&E CER	4	1.00	28	0	0	0.0		10,466
	UNIT CER	40	1.00	54				1 85	1,175
18 PRESS SYS 2736 LBS	14 DDT&E CER	4	1.00	28	0	0	0.0		6,513
	UNIT CER	40	1.00	54				1 85	619
19 PROP RCS	5 DDT&E SUBS	0	0.00	0	0	0	0.0		9,911
	UNIT SUBS	0	0.00	0				0 0	10,983
20 RCS ENG 2940 LBS	19 DDT&E CER	7	1.00	28	100	0	0.0		2,420
	UNIT CER	39	1.00	54				1 85	9,683
21 RCS PRES&LINES 1544 LBS	19 DDT&E CER	4	1.00	28	0	0	0.0		4,872
	UNIT CER	40	1.00	54				1 85	418
22 RCS TANKS 3475 LBS	19 DDT&E CER	62	1.00	28	0	0	0.0		2,618
	UNIT CER	63	1.00	54				1 85	882
23 PROP OMS	5 DDT&E SUBS	0	0.00	0	0	0	0.0		15,228
	UNIT SUBS	0	0.00	0				0 0	2,363
24 ENGINES	23 DDT&E \$	0	0.00	0	0	0	0.0		10,800
	UNIT \$	0	0.00	0				2 90	1,439

Table 5.1.3-2 (Continued)

25 PRESS&LINES 274 LBS	23 DDT&E CER	4	1.00	28	0	0	0.0		2,046
	UNIT CER	40	1.00	54				1 85	127
26 FUEL TANK 858 LBS	23 DDT&E CER	62	1.00	28	0	0	0.0		805
	UNIT CER	63	1.00	54				1 85	266
27 LO2 TANK 1913 LBS	23 DDT&E CER	62	1.00	28	0	0	0.0		1,576
	UNIT CER	63	1.00	54				1 85	529
28 PRIME POWER	5 DDT&E SUBS	0	0.00	0	0	0	0.0		11,430
	UNIT SUBS	0	0.00	0				0 0	5,396
29 APU 732 LBS	28 DDT&E CER	7	1.00	28	0	0	0.0		7,063
	UNIT CER	39	1.00	54				1 85	2,780
30 FUEL CELLS&TANKS 368 LBS	28 DDT&E CER	1	1.00	28	0	0	0.0		4,367
	UNIT CER	35	1.00	54				1 85	2,615
31 ELEC CONV/DIS	5 DDT&E SUBS	0	0.00	0	0	0	0.0		5,490
	UNIT SUBS	0	0.00	0				0 0	4,850
32 CONV EQU 330 LBS	31 DDT&E CER	18	1.00	28	0	0	0.0		1,248
	UNIT CER	49	1.00	54				1 85	1,250

Table 5.1.3-2 (Continued)

33 CONTROLS 221	LBS	31	DDT&E CER	18	1.00	28	0	0	0.0	899
			UNIT CER	49	1.00	54			1 85	875
34 CABLES AND CONTROLS 1099	LBS	31	DDT&E CER	15	1.00	29	0	0	0.0	3,342
			UNIT CER	47	1.00	54			1 85	2,725
35 AVIONICS		5	DDT&E SUBS	0	0.00	0	0	0	0.0	63,612
			UNIT SUBS	0	0.00	0			0 0	41,661
36 CONTROL 1717	LBS	35	DDT&E CER	17	1.00	28	0	0	0.0	57,145
			UNIT CER	48	1.00	54			1 85	34,682
37 COMMUNICATIONS 451	LBS	35	DDT&E CER	18	1.00	20	0	0	0.0	1,614
			UNIT CER	49	1.00	54			1 85	1,650
38 DATA HANDLING 1683	LBS	35	DDT&E CER	18	1.00	28	0	0	0.0	4,852
			UNIT CER	49	1.00	54			1 85	5,329
39 ECS		5	DDT&E SUBS	0	0.00	0	0	0	0.0	14,215
			UNIT SUBS	0	0.00	0			0 0	5,408
40 TANK PURGE 2277	LBS	39	DDT&E CER	4	1.00	28	0	0	0.0	5,933
			UNIT CER	40	1.00	54			1 85	546

D18C-20689-5

35

ORIGINAL PAGE IS
OF POOR QUALITY

Table 5.1.3-2 (Continued)

41 COMP BAYS 2750 LBS	39	DDT&E CER	23	1.00	28	0	0	0.0	8,282
		UNIT CER	41	1.00	54			1 85	4,862
42 PAYLOAD SYS 3024 LBS	5	DDT&E CER	6	1.00	28	0	0	0.0	11,549
		UNIT CER	37	1.00	54			1 85	1,197
43 ASSY&C/O	4	DDT&E N/A	0	0.00	0	0	0	0.0	0
		UNIT CER*	5	0.00	0			0 0	5,481
			61	0.00					
44 TOOLING	4	DDT&E FACTOR	5	0.50	0	0	0	0.0	459,792
		UNIT N/A	0	0.00	0			0 0	0
45 SYSTEM TEST	4	DDT&E SUBS	0	0.00	0	0	0	0.0	977,269
		UNIT N/A	0	0.00	0			0 0	0
46 SYS TEST LABOR	45	DDT&E CER*	5	0.00	0	0	0	0.0	104,027
			30	0.00					
		UNIT N/A	0	0.00	0			0 0	0
47 GR TEST HDWE	45	DDT&E FAC UN	5	1.50	0	0	0	0.0	374,246
		UNIT N/A	0	0.00	0			0 0	0
48 FLT TEST HDWE	45	DDT&E FAC UN	5	2.00	0	0	0	0.0	498,995
		UNIT N/A	0	0.00	0			0 0	0

D130-20689-5

36

ORIGINAL PAGE IS
OF POOR QUALITY

Table 5.1.3-2 (Continued)

49 SEGI	4 DDT&E CER*	5	0.00	0	0	0	0.0	43,335
	UNIT N/A	29	0.00	0	0	0	0.0	
		0	0.00	0			0 0	0
50 FLT VEH DD&T	0 DDT&E FACTOR	5	1.00	0	0	0	0.0	0
	UNIT N/A	49	1.00					
		46	1.00					
		0	0.00	0			0 0	0
51 SOFTWARE ENGR	4 DDT&E CER*	50	0.00	0	0	0	0.0	55,033
	UNIT N/A	33	0.00					
		0	0.00	0			0 0	0
52 GSE	4 DDT&E CER*	5	0.00	0	0	0	0.0	25,828
	UNIT CER*	56	0.00					
		5	0.00	0			0 0	27,921
		57	0.00					
53 FLT TEST OPS	1 DDT&E \$	0	0.00	0	0	0	0.0	108,000
	UNIT N/A	0	0.00	0				
							0 0	0
54 FLT VEH 1ST STAGE	3 DDT&E SUBS	0	0.00	0	0	0	0.0	4,613,484
	UNIT SUBS	0	0.00	0				
							0 0	551,629
55 FLT VEHICLE D&D	54 DDT&E SUBS	0	0.00	0	0	0	0.0	1,497,778
	UNIT SUBS	0	0.00	0				
							0 0	488,984
56 STRUCTURE	55 DDT&E SUBS	0	0.00	0	0	0	0.0	437,661
	UNIT SUBS	0	0.00	0				
							0 0	157,545

37 ORIGINAL PAGE IS
OF POOR QUALITY

D180-20689-5

Table 5.1.3-2 (Continued)

57 FWD SKIRT 25972 LBS	56 DDT&E CER	3	1.00	28	0	0	0.0		20,794
	UNIT CER	37	1.00	54				1 84	7,889
58 AFT SKIRT 144885 LBS	56 DDT&E CER	3	1.00	28	0	0	0.0		96,194
	UNIT CER	37	1.00	54				1 84	35,604
59 THRUS. STRUCTURE 154283 LBS	56 DDT&E CER	3	1.00	28	0	0	0.0		101,772
	UNIT CER	37	1.00	54				1 84	37,621
60 LIQUID OXYGEN TNK 92656 LBS	56 DDT&E CER	62	1.00	28	0	0	0.0		46,388
	UNIT CER	63	1.00	54				1 84	14,623
61 RP-1 TANK 90786 LBS	56 DDT&E CER	62	1.00	28	0	0	0.0		45,553
	UNIT CER	63	1.00	54				1 84	14,370
62 LH2 TANK 15046 LBS	56 DDT&E CER	3	1.00	28	0	0	0.0		12,850
	UNIT CER	37	1.00	54				1 84	4,488
63 BASE STRUCTURE 126863 LBS	56 DDT&E CER	3	1.00	28	0	0	0.0		85,395
	UNIT CER	37	1.00	54				1 84	31,690
64 SECONDARY STRUCTURE 37383 LBS	56 DDT&E CER	3	1.00	28	0	0	0.0		28,713
	UNIT CER	37	1.00	54				1 84	10,856

D180-20689-5

38

ORIGINAL PAGE IS
OF POOR QUALITY

ORIGINAL PAGE IS
OF POOR QUALITY

39

Table 5.1.3-2 (Continued)

65 TPS 9804 LBS	55 DDT&E CER	2	1.00	28	0	0	0.0		30,823
	UNIT CER	36	1.00	54				1 84	18,873
66 LANDING SYSTEM	55 DDT&E SUBS	0	0.00	0	0	0	0.0		161,639
	UNIT SUBS	0	0.00	0				0 0	71,236
67 SSME'S	66 DDT&E \$	0	0.00	0	0	0	0.0		32,500
	UNIT \$	0	0.00	0				6 90	63,298
68 SSME ACCES 978 LBS	66 DDT&E CER	5	1.00	28	0	0	0.0		17,999
	UNIT CER	40	1.00	54				6 89	1,558
69 PROP DELIVERY SYS 10380 LBS	66 DDT&E CER	4	1.00	28	0	0	0.0		12,879
	UNIT CER	40	1.00	54				1 84	1,552
70 PROP TANK 10913 LBS	66 DDT&E CER	62	1.00	28	0	0	0.0		7,032
	UNIT CER	63	1.00	54				1 84	2,347
71 SEPERATION SYS 5665 LBS	66 DDT&E CER	5	1.00	28	0	0	0.0		86,488
	UNIT CER	37	1.00	54				1 84	2,076
72 PRESS SYS 1462 LBS	66 DDT&E CER	4	1.00	28	0	0	0.0		4,739
	UNIT CER	40	1.00	54				1 84	402

D180-20689-5

Table 5.1.3-2 (Continued)

73 MAIN PROPULSION SYS	55	DDT&E SUBS	0	0.00	0	0	0	0.0		721,138
		UNIT SUBS	0	0.00	0				0 0	135,277
74 LO2/PP-1 ENGINES 1.95E6 THRUST	73	DDT&E CER	26	1.00	28	0	0	0.0		637,942
		UNIT CER	53	1.00	54				16 89	120,062
75 ENG ACCES 3056 LBS	73	DDT&E CER	5	1.00	28	0	0	0.0		49,693
		UNIT CER	40	1.00	54				16 89	8,056
76 PROP PFESS&DELIV SYS 95623 LBS	73	DDT&E CER	4	1.00	28	20	0	0.0		33,503
		UNIT CER	40	1.00	54				1 84	7,158
77 AUX PROPULSION SYS 3611 LBS	55	DDT&E CER	7	0.37	28	0	0	0.0		15,444
			4	0.19						
			62	0.44						
		UNIT CER	39	0.37	54				1 84	5,462
			40	0.19						
		63	0.44							
78 PRIME FCWER 1782 LBS	55	DDT&E CER	16	1.00	28	50	0	0.0		2,007
		UNIT CER	47	1.00	54				1 84	4,295
79 ELEC CONV&DIST 8041 LBS	55	DDT&E CER	18	0.20	28	0	0	0.0		17,289
			18	0.13						
			15	0.67						
		UNIT CER	44	0.20	54				1 84	20,777
			49	0.13						
		47	0.67							

40

ORIGINAL PAGE IS
OF POOR QUALITY

D180-20689-5

Table 5.1.3-2 (Continued)

80 HYDRAULIC SYSTEM 23945 LBS	55 DDT&E CER	4	1.00	28	0	0	0.0		19,812
	UNIT CER	40	1.00	54				1 84	2,759
81 AVIONICS 5895 LBS	55 DDT&E CER	17	0.50	28	10	25	0.0		64,886
		18	0.50					1 84	62,237
	UNIT CER	48	0.50	54					
		49	0.50						
82 ECS 12660 LBS	55 DDT&E CER	4	0.40	28	0	0	0.0		27,075
		23	0.60					1 84	10,519
	UNIT CER	80	0.40	54					
		81	0.60						
83 ASSY&C/O	54 DDT&E N/A	0	0.00	0	0	0	0.0		0
	UNIT CER*	55	0.00	0				0 0	9,866
		61	0.00						
84 TOOLING	54 DDT&E FACTOR	55	0.50	0	0	0	0.0		760,413
	UNIT N/A	0	0.00	0				0 0	0
85 SYS TEST	54 DDT&E SUBS	0	0.00	0	0	0	0.0		2,232,628
	UNIT SUBS	0	0.00	0				0 0	0
86 SYS TEST LABOR	85 DDT&E CER*	55	0.00	0	0	0	0.0		32,199
		30	0.00					0 0	0
	UNIT N/A	0	0.00	0					
87 GND TEST HDWE	85 DDT&E FAC UN	55	2.50	0	0	0	0.0		1,224,460
	UNIT N/A	0	0.00	0				0 0	0

D180-20689-5

ORIGINAL PAGE IS
OF POOR QUALITY

Table S.1.3-2 (Continued)

88 FLT TEST HDWE	85 DDT&E PAC UN	55	2.00	0	0	0	0.0		977,968
	UNIT N/A	0	0.00	0				0 0	0
89 SE&I	54 DDT&E CER*	55	0.00	0	0	0	0.0		14,879
		29	0.00					0 0	0
	UNIT N/A	0	0.00	0					0
90 FLT VEHICLE DD&T	0 DDT&E FACTOR	55	1.00	0	0	0	0.0		0
		89	1.00						0
		86	1.00					0 0	0
	UNIT N/A	0	0.00	0					0
91 SOFTWARE ENGINEERING	54 DDT&E CER*	90	0.00	0	0	0	0.0		72,686
		33	0.00					0 0	0
	UNIT N/A	0	0.00	0					0
92 GSE	54 DDT&E CER*	55	0.00	0	0	0	0.0		35,109
		56	0.00					0 0	52,778
	UNIT CER*	55	0.00	0					
		57	0.00						
93 HYDRAULIC CONV/DIST 8708 LBS	5 DDT&E CER	4	1.00	28	0	0	0.0		11,768
	UNIT CER	40	1.00	54				1 85	1,375
94	0 DDT&E SUBS	0	0.00	0	0	0	0.0		0
	UNIT SUBS	0	0.00	0				0 0	0
95	0 DDT&E SUBS	0	0.00	0	0	0	0.0		0
	UNIT SUBS	0	0.00	0				0 0	0

D180-20689-5

5.1.4 Tanker/Cargo Shroud

5.1.4.1 System Description

The two payload section options of the two stage ballistic recoverable vehicle include an LH₂/LO₂ tanker and a 75 kg/m³ payload shroud as shown in Figure 5.1.4-1.

Tanker Option—The tanker option has been sized to provide 400 metric tons of propellant in a 5.5:1 mixture ratio relationship. Independent elliptical tankage provides 939 m³ and 297 m³ volumes for the LH₂ and LO₂ propellants respectively. The maximum tank design pressures are experienced during the boost maximum acceleration conditions. The peak design and proof test pressures and the resulting tank wall membrane thickness are shown in Table 5.1.4-1. Both tanks are fabricated from 2219-T87 aluminum alloy.

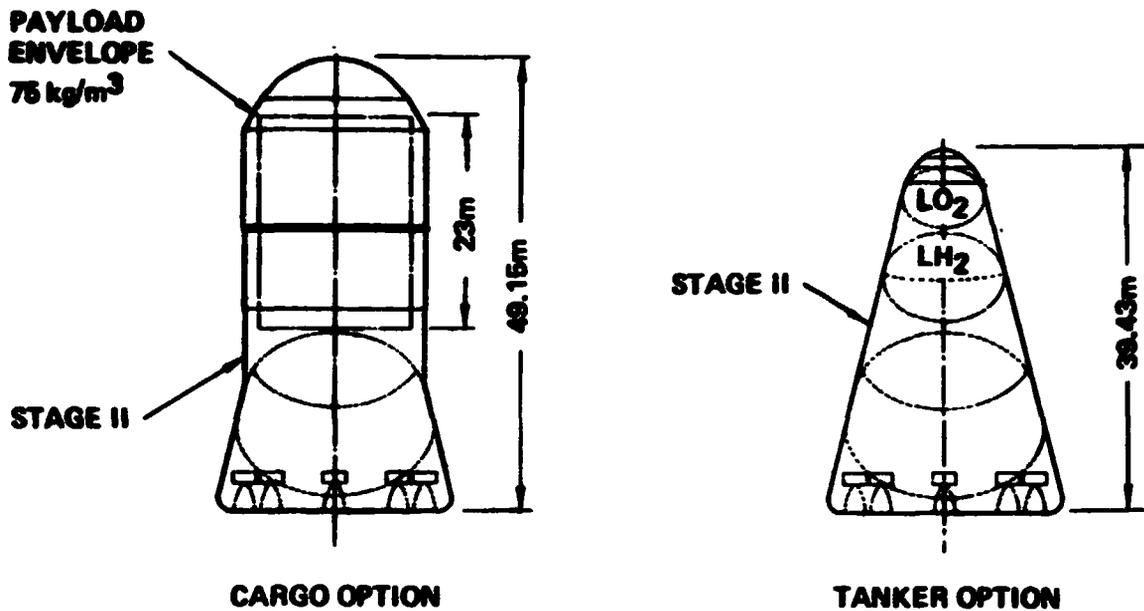

Figure 5.1.4-1 2-Stage Ballistic Vehicle Payload Shroud Options

Table 5.1.4-1 Tank Sizing Criteria and Results

Tank	Max. Operating Pressure - kpa	Max. Proof Test Pressure - kpa	Membrane Thickness Variation - cm	Mass-kg
LO ₂	485	645	.43 - .61	3746
LH ₂	183	244	.25 - .35	5161

Non-pressurized structure includes the nose cap, intertank, and aft skirt elements. These structural elements have been sized in 6A1-4V titanium. The total mass of these elements has been estimated at 11718 kg.

The thermal protection system (TPS) includes the internal LH₂ tank insulation and the reusable insulation on the forward portion of the tanker. A total TPS mass of 1724 kg has been estimated.

Mechanisms on the tanker include the forward door actuation system and docking provisions. A total mass of 2190 kg has been estimated for the tanker mechanisms.

A cold gas pressurization system has been included on-board the tanker. This option has been selected to insure positive pressure in the tanks during reentry and also to assist in on-orbit propellant transfer operations. A total mass of 7635 kg for the pressurization subsystem includes the delivery lines and transfer system and the pressurization system.

The tanker dry mass is estimated to be 35391 kg.

Cargo Shroud—A three-section telescoping shroud concept has been selected as the reference cargo shroud concept. Shroud reusability is a significant factor in achieving low cost per flight. The shroud has been sized to handle a 17 meter in diameter by 23 meter long payload package containing SPS components. The shroud operational scheme is for the shroud to be extended to its full length on the ground prior to payload installation and then to be retracted on-orbit after payload deployment and prior to reentry.

The shroud structural subsystem consists of the 3 cylindrical sections and the combination door/nosecap. All elements are fabricated from 6AL-4V titanium. Each cylindrical section includes the skin shell, rails (longerons) and frames. A two piece nose cap provides complete access to the payload package. The estimated mass for the structural subsystem is 20157 kg.

The shroud thermal protection system is the reusable high temperature insulation required for ascent heating. The total TPS mass is 5415 kg.

The mass of the mechanisms for door actuation and translating the retractable shroud have been estimated at 7433 kg based on extrapolation of historical data.

5.1.4.2 Tanker/Cargo Shroud Mass Characteristics

The mass characteristics for the two payload section options reflect the results of a preliminary structural sizing and incorporation of historical weight estimating relationships. A mass summary of the tanker and cargo shroud options are shown in Table 5.1.4-2. A 10% mass growth allowance has been included in the estimate. The tanker mass includes an estimated 1018 kg of residuals and unusables as a result of propellant transfer operations.

5.1.4.3 Tanker/Cargo Shroud Cost Estimates

The DDT&E and 1st unit production costs have been estimated for both the tanker and cargo shroud payload options in a manner similar to that used for cost estimating the vehicle stages. The work breakdown structure and resulting costs are shown in Tables 5.1.4-3 and -4 for the tanker and cargo shroud, respectively.

The total tanker DDT&E cost is \$388.1M and includes 1.5 ground test units and 2.0 flight test units. The tanker first unit cost of \$50.8M is driven by the structures and mechanism's cost which account for 60% of the initial unit cost.

The total cargo shroud DDT&E cost is \$490.6M and also includes 1.5 ground test units and 2.0 flight test units. The cargo shroud first unit cost of \$78.3M is driven by the mechanism and structure costs which are 67% of the total cost.

Table 5.1.4-2 Tanker and Cargo Shroud Mass Statement

Tanker		<u>kg</u>	Cargo Shroud		<u>kg</u>
Structure	(20 625)		Structure	(20 157)	
Nosecap		1134	Cylinder section no. 1		4391
LO ₂ tank		3746	Cylinder section no. 2		4697
Intertank		3561	Cylinder section no. 3		5481
LH ₂ tank		5161	Nose section		5588
Aft skirt		7023			
TPS	(1724)		TPS		5415
Internal		772	Mechanisms		7433
External		952			
Mechanisms	(2190)	2190	Mass growth (10%)		3300
Propellant system	(7635)				
Lines and transfer system		2268			
Pressure system		5367			
Mass growth (10%)	(3217)	<u>3217</u>			
		35 391			
		1018			
		<u>36 409</u>			
			Inert mass		<u>36 305</u>

Table 5.1.4-3 Tanker DDT&E and 1st Unit Production Costs

NC	NAME	SUB ELEMENT TO	METHOD	SOURCES	BLEND FACTORS	SUPT FROM	CTS %	MOD %	MOD CNPLX	NUMBER	LWN %	COST (000)
1	TOTAL PROGRAM	0	DDT&E SUBS	0	0.00	0	0	0	0.0			388,131
			UNIT SUBS	0	0.00	0				0	0	50,863
2	PROGRAM INTECMANAG	1	DDT&E FACTOR	3	0.10	0	0	0	0.0			22,692
			UNIT FACTOR	3	0.10	0				0	0	5,114
3	FLT VEHICLE TANKER	1	DDT&E SUBS	0	0.00	0	0	0	0.0			365,438
			UNIT SUBS	0	0.00	0				0	0	45,728
4	TANKER DED	3	DDT&E SUBS	0	0.00	0	0	0	0.0			99,090
			UNIT SUBS	0	0.00	0				0	0	37,862
5	STRUCTURE	4	DDT&E SUBS	0	0.00	0	0	0	0.0			46,831
			UNIT SUBS	0	0.00	0				0	0	19,112
6	NOSE 2749 LBS	5	DDT&E CER	2	1.00	28	0	0	0.0			10,679
			UNIT CER	36	1.00	54				1	85	6,012
7	L22 TANK 9084 LBS	5	DDT&E CER	62	1.00	28	0	0	0.0			5,995
			UNIT CER	63	1.00	54				1	85	2,006
8	INTERTANK 8635 LBS	5	DDT&E CER	3	1.00	28	0	0	0.0			7,900
			UNIT CER	37	1.00	54				1	85	3,004

47

ORIGINAL PAGE IS
OF POOR QUALITY

D180-20689-5

Table 5.1.4-3 (Continued)

9 LH2 TANK 12517	LBS	5 DDTCE CER	62	1.00	28	0	0	0.0		7,925
		UNIT CER	69	1.00	54				1 85	2,639
10 AFT SKIRT 17031	LBS	5 DDTCE CER	3	1.00	28	0	0	0.0		14,330
		UNIT CER	37	1.00	54				1 85	5,449
11 TPS 2553	SQF	4 DDTCE CER	64	3.00	28	0	0	0.0		10,025
		UNIT CER	65	3.00	54				1 85	5,056
12 DOCKING MECH 5313	LBS	4 DDTCE CER	2	1.00	28	0	0	0.0		18,465
		UNIT CER	36	1.00	54				1 85	10,876
13 DUCTS & TRANS SYS 5500	LBS	4 DDTCE CER	4	1.00	28	0	0	0.0		9,299
		UNIT CER	40	1.00	54				1 85	1,002
14 ASSY & C/D		3 DDTCE N/A	0	0.00	0	0	0	0.0		0
		UNIT CER*	4	0.00	0				0 0	1,257
15 TOOLING		3 DDTCE FACTOR	4	0.50	0	0	0	0.0		89,873
		UNIT N/A	0	0.00	0				0 0	0
16 SYS TEST		3 DDTCE SUBS	0	0.00	0	0	0	0.0		153,287
		UNIT SUBS	0	0.00	0				0 0	0

Table 5.1.4-3 (Continued)

17 SYS TEST LABOR	16	DDTCE CER*	4	0.00	0	0	0	0.0		20,768
			30	0.00						
	UNIT	N/A	0	0.00	0				0 0	0
18 GND TEST HDWE	16	DDTCE FAC UN	4	1.50	0	0	0	0.0		56,794
			0	0.00	0				0 0	0
	UNIT	N/A	0	0.00	0				0 0	0
19 FLT TEST HDWE	16	DDTCE FAC UN	4	2.00	0	0	0	0.0		75,725
			0	0.00	0				0 0	0
	UNIT	N/A	0	0.00	0				0 0	0
20 SECI	3	DDTCE CER*	4	0.00	0	0	0	0.0		9,976
			29	0.00						
	UNIT	FACTOR	4	0.05	0				0 0	938
21 FLT VEH DDCT	0	DDTCE FACTOR	4	1.00	0	0	0	0.0		0
			20	1.00						
			17	1.00						
	UNIT	N/A	0	0.00	0				0 0	0
22 SOFTWARE ENG	3	DDTCE CER*	21	0.00	0	0	0	0.0		3,665
			34	0.00						
	UNIT	N/A	0	0.00	0				0 0	0
23 GSE	3	DDTCE CER*	4	0.00	0	0	0	0.0		9,545
			56	0.00						
	UNIT	CER*	4	0.00	0				0 0	5,669
			57	0.00						
24 PRES SYS 13014 LBS	4	DDTCE CER	4	1.00	28	0	0	0.0		14,467
			40	1.00	54				1 85	1,813

49

ORIGINAL PAGE IS
OF POOR QUALITY

D180-20689-5

Table 5.1.4-4 Cargo Shroud DDT&E and 1st Unit Production Costs

NO	NAME	SUB ELEMENT TO	METHOD	SOURCES	BLEND FACTORS	SUPT FROM	QTS	MOD %	MOD %	MOD CMPLX	NUMBER	LRN %	COST (000)
1	TOTAL PROGRAM	0	DDT&E SUBS	0	0.00	0	0	0	0	0.0			490,613
			UNIT SUBS	0	0.00	0					0	0	78,283
2	PROGRAM INTECMANAG	1	DDT&E FACTOR	3	0.10	0	0	0	0	0.0			25,553
			UNIT FACTOR	3	0.10	0					0	0	7,877
3	FLT YEH CARGO SHROUD	1	DDT&E SUBS	0	0.00	0	0	0	0	0.0			465,060
			UNIT SUBS	0	0.00	0					0	0	70,405
4	CARGO FLYER DEL	3	DDT&E SUBS	0	0.00	0	0	0	0	0.0			111,467
			UNIT SUBS	0	0.00	0					0	0	58,035
5	STRUCTURE	4	DDT&E SUBS	0	0.00	0	0	0	0	0.0			62,799
			UNIT SUBS	0	0.00	0					0	0	16,285
6	CYL SEC NO. 1 10648 LBS	5	DDT&E CER	3	1.00	28	0	0	0	0.0			9,488
			UNIT CER	37	1.00	54					1	85	3,610
7	CYL SEC NO. 2 11389 LBS	5	DDT&E CER	3	1.00	28	0	0	0	0.0			10,064
			UNIT CER	37	1.00	54					1	85	3,829
8	CYL SEC NO. 3 13292 LBS	5	DDT&E CER	3	1.00	28	0	0	0	0.0			11,524
			UNIT CER	37	1.00	54					1	85	4,385

50

D180-20689-5

ORIGINAL PAGE IS
OF POOR QUALITY

ORIGINAL PAGE IS
OF POOR QUALITY

51

Table S.1.4-4 (Continued)

9 NOSE SECTION 13591 LBS	3	DDTCE CER	3	1.00	28	0	0	0.0	11,721
		UNIT CER	37	1.00	54			1.85	4,460
7 SHELL MECH 9776 LBS	4	DDTCE CER	2	1.00	28	0	0	0.0	30,749
		UNIT CER	36	1.00	54			1.85	10,825
11 TPS 2985 SOF	4	DDTCE CER	64	2.00	28	0	0	0.0	8,228
		UNIT CER	65	2.00	54			1.85	5,689
12 JACKING MECH 5500 LBS	4	DDTCE CER	2	1.00	28	0	0	0.0	19,006
		UNIT CER	36	1.00	54			1.85	11,220
13 DOOR MECH 2750 LBS	4	DDTCE CER	2	1.00	28	0	0	0.0	10,683
		UNIT CER	36	1.00	54			1.85	6,014
14 ASSY & C/O	3	DDTCE N/A	0	0.00	0	0	0	0.0	0
		UNIT CER*	4	0.00	0			0 0	1,928
			81	0.00					
15 TOOLING	3	DDTCE FACTOR	4	0.50	0	0	0	0.0	101,401
		UNIT N/A	0	0.00	0			0 0	0
16 SYS TEST	3	DDTCE SUBS	0	0.00	0	0	0	0.0	228,658
		UNIT SUBS	0	0.00	0			0 0	0

D180-20689-5

Table 5.1.4-4 (Continued)

17	SYS TEST LABOR	16	DDTCE CER*	4	0.00	0	0	0	0.0	23,536	
				30	0.00						
			UNIT N/A	0	0.00	0			0 0	0	
18	GND TEST HDWE	16	DDTCE FAC UN	4	1.50	0	0	0	0.0	87,052	
				0	0.00	0					
			UNIT N/A	0	0.00	0			0 0	0	
19	FLT TEST HDWE	16	DDTCE FAC UN	4	2.00	0	0	0	0.0	116,070	
				0	0.00	0					
			UNIT N/A	0	0.00	0			0 0	0	
20	SECT	3	DDTCE CER*	4	0.00	0	0	0	0.0	17,182	
				29	0.00						
			UNIT FACTOR	4	0.05	0			0 0		1,438
21	FLT VEH DDLT	0	DDTCE FACTOR	4	1.00	0	0	0	0.0	0	
				20	1.00						
				17	1.00						
			UNIT N/A	0	0.00	0			0 0		0
22	SOFTWARE ENG	3	DDTCE CER*	23	0.00	0	0	0	0.0	4,039	
				34	0.00						
			UNIT N/A	0	0.00	0			0 0		0
23	GSE	3	DDTCE CER*	4	0.00	0	0	0	0.0	10,312	
				56	0.00						
			UNIT CER*	4	0.00	0			0 0		9,004
				57	0.00						
24		0	DDTCE SUBS	0	0.00	0	0	0	0.0	0	
				0	0.00	0			0 0		0
			UNIT SUBS	0	0.00	0			0 0	0	

5.1.5 Vehicle Performance

The vehicle performance for the SPS mission was calculated based on the following groundrules:

- Kennedy Space Center (KSC) was the launch site (latitude = 28.5°)
- ΔV Reserves = .85% ΔV_i
- Delivery orbit
 - Altitude = 477 km circular
 - Inclination = 31°
- Upper stage circularizes and transfers the payload to a staging depot or LEO construction base.

This particular delivery orbit allows for two launch opportunities to each orbit $\approx 1/3$ hours apart. The upper stage, since it delivers the payload to a LEO base, deorbits approximately 24 hours later to return to a landing near the launch site.

The ascent trajectory characteristics for the vehicle are shown in Figure 5.1.5-1. The major characteristics are summarized as follows:

First Stage

T/W @ Ignition = 1.30
Maximum Dynamic Pressure = 32.125 kpa
Maximum Acceleration = 4.90 g's
Stage Burn Time = 176.89 sec.
Dynamic Pressure at Staging = 405 pa

Second Stage

T/W @ Ignition = 0.76
Maximum Acceleration = 2.28 g's
Stage Burn Time = 394.84 sec.

At main engine cutoff (MECO) the trajectory characteristics are as follows:

Altitude = 110948 m
Relative Velocity = 7540 m/sec
Burnout Mass = 749585 kg

D180-20689-5

The circularization burn of 105.6 m/sec and a trim burn of 10.56 m/sec (10% of circularization burn) are performed by the orbit maneuvering system (OMS).

In addition, an RCS trim burn of 17 m/sec is performed. The net payload deployed is 391450 kg and the upper stage landed mass is 279855 kg including the cargo shroud.

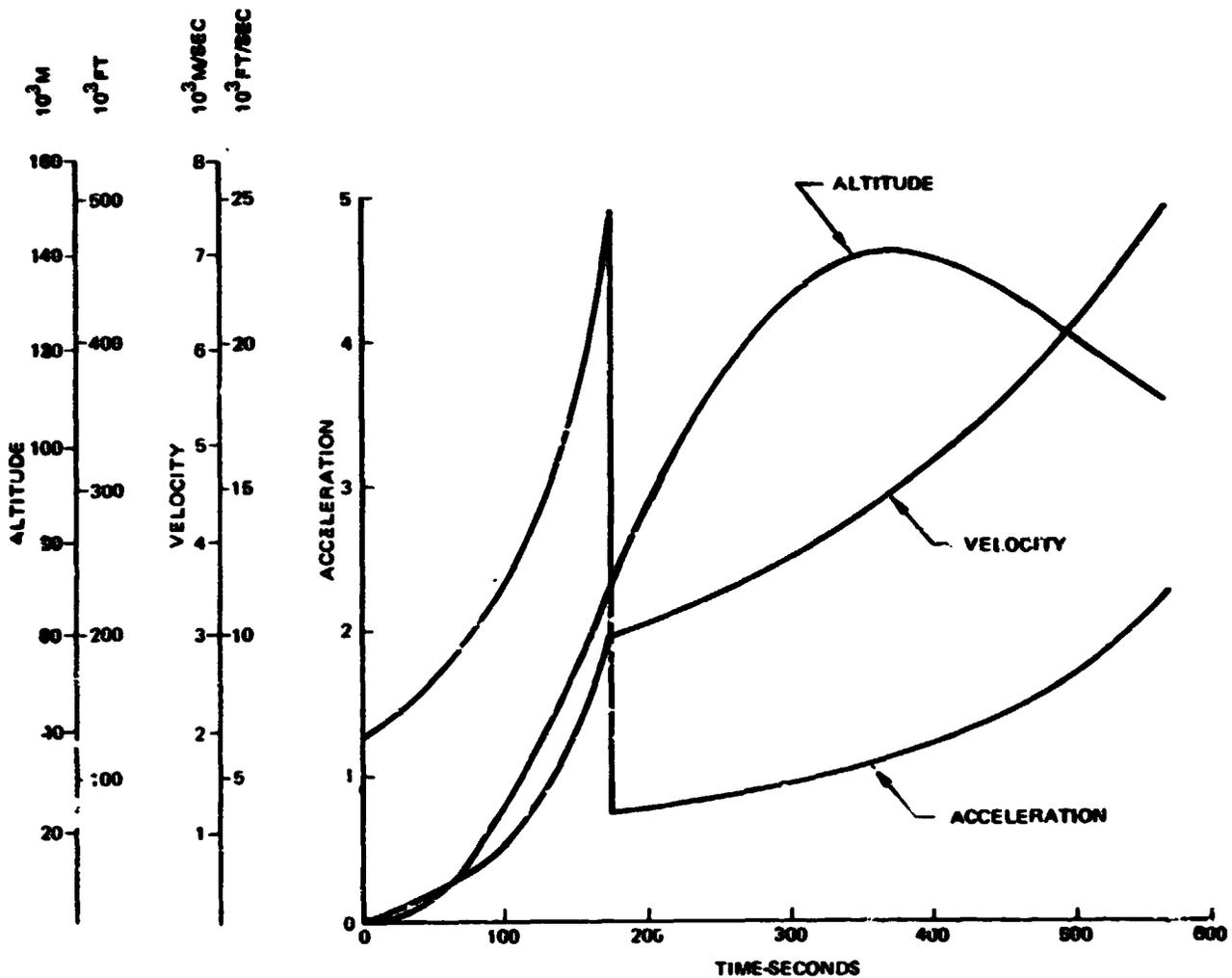

Figure 5.1.5-1 2-Stage Ballistic Vehicle Ascent Performance Characteristics

5.1.6 Vehicle Operations

The 2-stage ballistic recoverable vehicle operations plan includes the pre-launch, launch, and recovery activities associated with the launch vehicle. The first and second stage flow diagram for a typical turnaround is shown on Figure 5.1.6-1. Stage processing, integration and launch timelines are noted. In addition, recovery ship operations are shown.

The stage processing activities are conducted in low bay areas of a vertical assembly building (VAB). These activities include stage inspections and performing required maintenance effort. Vertical stage stacking and integration verification testing will be conducted in high bay areas of the vertical assembly building. Self-powered water transportable mobile launcher platforms (MLP's) are utilized for transport of the vehicle from the vertical assembly building to the off-shore launch site. Payload installation will be performed in the VAB. The fixed portion of the launch site will include the tower with its service arms and support pedestals for the MLP.

The SPS mission requirements of installing four satellites per year place a demanding launch rate on the launch vehicle. For the two construction locations, LEO or GEO, an annual flight rate of 3125 and 1875 are required. The weekly flight SPS freighter rate for GEO construction is shown in Figure 5.1.6-2.

Four orbits all inclined at 31° , but equally spaced in longitude (90° apart), are the baseline delivery orbits and are noted by the symbols on upper portion of the chart. At the initial opportunity to a given orbit (northerly) both a cargo and tanker payload are launched within 15 minutes of each other. Approximately $3 \frac{1}{3}$ hours later, on the southerly opportunity, a single tanker flight is launched. LEO construction would require 8 flights per day versus the 12 flights required for GEO assembly. In the case of LEO construction, the salvo launch on the initial opportunity is not required resulting in only a single launch at each opportunity. The basic weekly turnaround for GEO construction, shown in Figure 5.1.6-2, requires 36 first stages and 45 upper stages in the active turnaround.

The ground operations manpower required to support the 12 launches/day for GEO assembly is shown in Table 5.1.6-1. The task breakdowns shown comprise the major activities necessary to recycle the vehicle. Both operations manpower and the associated maintenance personnel are identified. Approximately 676 men are involved in processing each vehicle in the turnaround and the resulting cost per flight is \$379,000.

The estimated facility costs for the GEO and LEO assembly options are shown in Table 5.1.6-2. The major facilities and recovery ships are noted on the table. A +\$5.2B facilities cost difference has been identified for GEO assembly as compared LEO assembly.

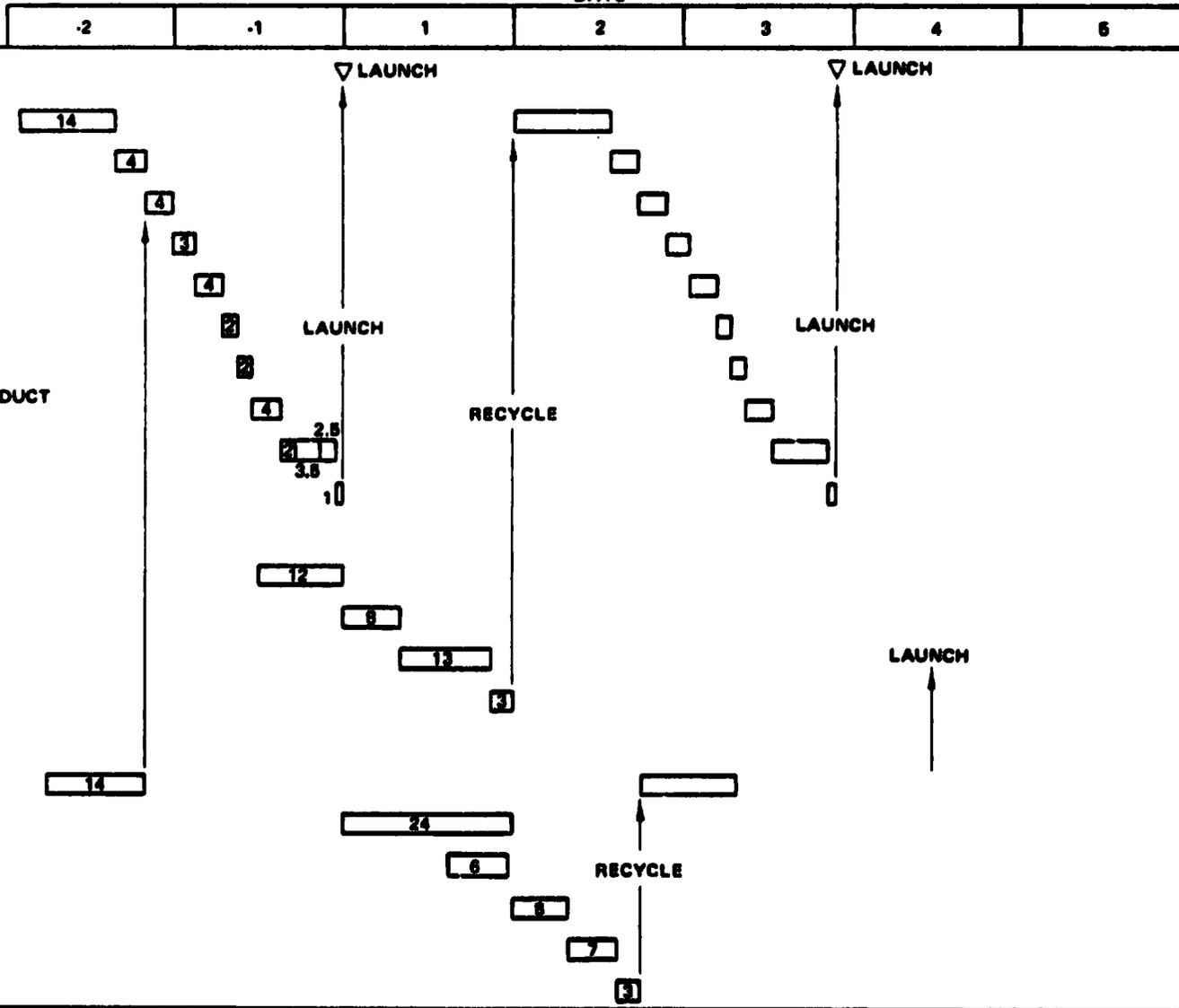

56

ORIGINAL PAGE IS
OF POOR QUALITY

D180-20689-5

Figure 5.1.6-1 Typical First and Second Stage Turn Around

Table 5.1.6-1 Ground Operations Tasks & Manloadings

	ANNUAL OPERATIONS HEADCOUNT	
	OPERATIONS	MAINTENANCE
FIRST STAGE PROCESSING	1223 -VEHICLE INSPECTIONS	2358 INSPECTION PICKUP & MAINT
SECOND STAGE PROCESSING	1154 -VEHICLE INSPECTIONS	2168 INSPECTION PICKUP & MAINT
MOBILE LAUNCHER ACTIVITIES	1075	4886 EQUIPMENT MAINTENANCE
FIRST & SECOND STAGE INSTALLATION ON MOBILE LAUNCHER	403	
VEHICLE INTEGRATION TESTING	161	
PAYLOAD INSTALLATION & CHECKOUT	161	
SUPPORT FOR MOVE TO LAUNCH SITE	242	
FIRST STAGE RECOVERY OPERATIONS	2328	602 EQUIPMENT MAINTENANCE
VAB TEST STATION	1566	576 EQUIPMENT MAINTENANCE
SECOND STAGE RECOVERY OPERATIONS	604	96 EQUIPMENT MAINTENANCE
LAUNCH CONTROL CENTER	1206	144 EQUIPMENT MAINTENANCE
LAUNCH SITE INSTALLATION & CHECKOUT	645	336 EQUIPMENT MAINTENANCE
PROPELLANT SYSTEM	1276	706 EQUIPMENT MAINTENANCE
GAS STORAGE & DISTRIBUTION	288	144 EQUIPMENT
Σ	= 12332	= 11996

58

D180-20689-5

● 36 VEHICLES IN THE TURNAROUND AT ANYTIME

PERSONNEL/VEHICLE = 678

TOTAL COST = \$1184M
COST/FLT = \$0.379M

Table 5.1.6-2 Estimated Facility Costs – Ballistic/Ballistic Launch Vehicle Ship Recovery

	UNIT COST	LEO CONSTRUCTION NUMBER	LEO CONSTRUCTION COST	GEO CONSTRUCTION NUMBER	GEO CONSTRUCTION COST
VAB POSITIONS	\$542	12	\$6,504	18	\$9,756
LAUNCH POSITIONS	116	8	928	12	1,392
MOBILE LAUNCH PLATFORMS	100	18/2	2,000	27/3	3,000
RECOVERY SHIPS	80	8/2	800	12/2	1,120
LCC FIRING ROOMS	26	8	208	12	312
PAYLOAD PROCESSING POSITIONS	76	4	304	4	304
SECOND STAGE RECOVERY FACILITIES			510		525
			<u>510</u>		<u>525</u>
			\$11,254		\$16,409

COSTS IN MILLIONS

D180-20689-5

D180-20689-5

5.1.7 2-Stage Ballistic SPS Freighter Cost per Flight

The cost per flight of the 2-stage ballistic SPS Freighter was developed to the operations cost work breakdown structure (WBS) shown in Table 5.1.7-1. This WBS is very similar to the Shuttle User Charge WBS with the exception of including production cost of reusable hardware and tooling costs associated with the tooling shipsets required to support rate production.

An annual launch rate of 3125 flights for GEO construction and 1875 flights for LEO construction over a period of 14 years was used to amortize the operating cost. A detail discussion of the methodology of developing cost per flight data can be found in Section 5.2.7. The following paragraphs will summarize the results of the cost per flight analysis.

The equivalent flight hardware units to satisfy life, refurbishment and replenishment spares over 14 years of operation for both GEO and LEO assembly are as follows:

Hardware Element	Equivalent Units	
	GEO Assy	LEO Assy
Booster Airframe	313	188
Booster LO ₂ /RP-1 Engines	8160	4934
Booster SSME's	2273	1378
Upper Stage Airframe	313	188
Upper Stage SSME's	4136	2506
Cargo Shroud	104	188
Tanker	210	N/A

The summarized cost/flight for GEO assembly is shown on Table 5.1.7-2. The average cost per flight of \$7.615M includes the Program Direct (81%), Direct Manpower (9%) and Indirect Manpower (10%) categories. Production and Spares plus Ground Operations/Systems account for ~3% of the total cost per flight.

LEO assembly cost/flight is summarized in Table 5.1.7-3. The average cost per flight of \$8.332 includes the same categories as reported for GEO assembly. The 9% increase in the average cost per flight is due primarily to the influence of rate on the costs.

Table 5.1.7-1 Operations Cost/Flight WBS

SPS-590

WBS ELEMENT
OPERATIONS COST
PROGRAM DIRECT
PROGRAM SUPPORT
PRODUCTION AND SPARES
STAGE 1
AIRFRAME
ENGINES
STAGE 2
AIRFRAME
ENGINES
TOOLING
STAGE 1
STAGE 2
GROUND OPS/SYS
GROUND OPS
GROUND SYS
GSE SUSTAINING ENGR
GSE SPARES
PROPELLANT
OTHER
DIRECT MANPOWER
CIVIL SERVICE
SUPPORT CONTRACTOR
INDIRECT MANPOWER
CIVIL SERVICE
SUPPORT CONTRACTOR

Table 5.1.7-2 2-Stage Ballistic Vehicle Average Operating Cost/Flight—GEO Assembly

SFS 502

WBS ELEMENT	COST BY WBS LEVEL — \$M				
	①	②	③	④	⑤
OPERATIONS COST	7.615				
PROGRAM DIRECT		6.198			
PROGRAM SUPPORT			0.281		
PRODUCTION AND SPARES			2.986		
STAGE 1				1.835	
AIRFRAME					0.943
ENGINES					0.892
STAGE 2				0.990	
AIRFRAME					0.517
ENGINES					0.473
PAYLOAD SHROUD				0.161	
TOOLING			0.383		
STAGE 1				0.258	
STAGE 2				0.107	
PAYLOAD SHROUD				0.018	
GROUND OPS/SYS			2.548		
GROUND OPS				0.379	
GROUND SYS				0.050	
GSE SUSTAINING ENGR				0.047	
GSE SPARES				0.091	
PROPELLANT				1.964	
OTHER				0.017	
DIRECT MANPOWER		0.682			
CIVIL SERVICE			0.357		
SUPPORT CONTRACTOR			0.325		
INDIRECT MANPOWER		0.735			
CIVIL SERVICE			0.400		
SUPPORT CONTRACTOR			0.335		

2

ORIGINAL PAGE IS
OF POOR QUALITY

D180-20689-5

Table 5.1.7-3 2 Stage Ballistic Vehicle Average Operating Cost/Flight – LEO Assembly

WBS ELEMENT	COST BY WBS LEVEL -- \$M				
	①	②	③	④	⑤
OPERATIONS COST	8.332				
PROGRAM DIRECT		6.755			
PROGRAM SUPPORT			0.317		
PRODUCTION AND SPARES			3.342		
STAGE 1				2.032	
AIRFRAME					1.061
ENGINES					0.971
STAGE 2				1.097	
AIRFRAME					0.581
ENGINES					0.516
PAYLOAD SHROUD				0.213	
TOOLING			0.466		
STAGE 1				0.318	
STAGE 2				0.132	
PAYLOAD SHROUD				0.016	
GROUND OPS/SYS			2.630		
GROUND OPS				0.426	
GROUND SYS				0.056	
GSE SUSTAINING ENGR				0.053	
GSE SPARES				0.112	
PROPELLANT				1.934	
OTHER				0.019	
DIRECT MANPOWER		0.768			
CIVIL SERVICE			0.402		
SUPPORT CONTRACTOR			0.366		
INDIRECT MANPOWER		0.809			
CIVIL SERVICE			0.451		
SUPPORT CONTRACTOR			0.358		

TABLE OF CONTENTS

	Page
5.2.1 Vehicle Geometry	67
5.2.2 Booster Stage	71
5.2.2.1 System Description	71
5.2.2.1.1 Ascent Propulsion	71
5.2.2.1.2 Structures	72
5.2.2.1.3 Thermal Protection	74
5.2.2.1.4 Landing Gear	74
5.2.2.1.5 Other Subsystems	74
5.2.2.2 Booster Mass Characteristics	75
5.2.2.3 Booster Cost Estimate	75
5.2.3 Upper Stage	88
5.2.3.1 System Description	88
5.2.3.1.1 Ascent Propulsion	88
5.2.3.1.2 Structures	89
5.2.3.1.3 Thermal Protection	90
5.2.3.1.4 Landing Gear	90
5.2.3.1.5 Other Subsystems	90
5.2.3.2 Upper Stage Mass Characteristics	92
5.2.3.3 Upper Stage Cost Estimate	92
5.2.4 Vehicle Performance	104
5.2.5 Vehicle Operations	106
5.2.6 2-Stage Winged Vehicle Cost per Flight	112

6.4
7
PAGE INTENTIONALLY BLANK

5.2 TWO-STAGE WINGED/WINGED LEO FREIGHTER

The two stage winged vehicle, shown in Figure 5.2-1, is a modified version of the NASA/JSC concept EDIN Ex-338-76. The vehicle is a tandem arrangement, series-burn concept and its characteristics are noted on the figure. Sixteen $\text{LO}_2/\text{RP-1}$ gas generator cycle, LH_2 cooled engines are incorporated on the first stage and 14 standard SSME's ($\epsilon=77.5$) are used on the upper stage. Within the overall vehicle's 9566 M ton gross liftoff mass, the booster and upper stage propellant loads are 5696 M tons and 2306 M tons respectively. The overall vehicle length is 140.73 M and the maximum wing span is 60.48 M for the booster. A cargo compartment with an average payload density of 135 kg/in^3 is provided in the nose section of the upper stage. A tanker version would incorporate independent internal tankage within the upper stage nose section. A retractable booster nose cap is provided to eliminate the need for an expendable interstage.

The vehicle operational characteristics include a downrange booster landing and an upper stage which remains on-orbit for 24 hours and then de-orbits for a landing at the launch site.

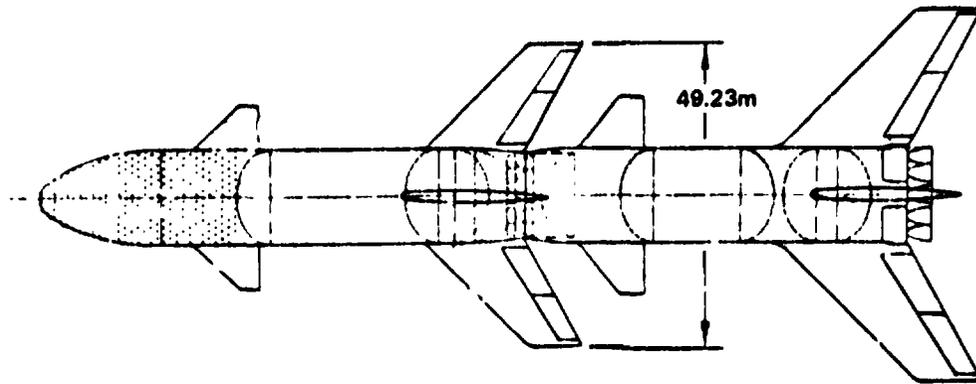

VEHICLE CHARACTERISTICS

- GLOW = 9.566×10^6 kg
- BLOW = 6.445×10^6 kg
 $W_{p1} = 5.696 \times 10^6$ kg
- ULOW = 2.739×10^6 kg
 $W_{p2} = 2.306 \times 10^6$ kg
- PAYLOAD = 0.381×10^6 kg
- T/W AT LIFTOFF = 1.30
- MAIN PROPULSION

STAGE	NUMBER & TYPE	ϵ	THRUST/ENG. (10 ⁶ N VAC.)	I_{sp} -Vac. (Sec.)
1st	16-LO ₂ /RP-1	42.6	6.275	380.7
2nd	14-SBME	77.5	2.091	485.2

D180-20689-5

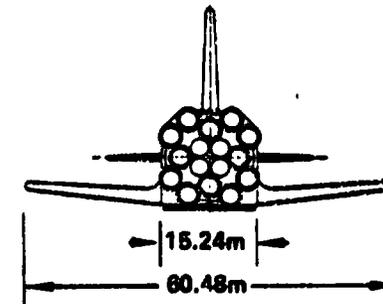
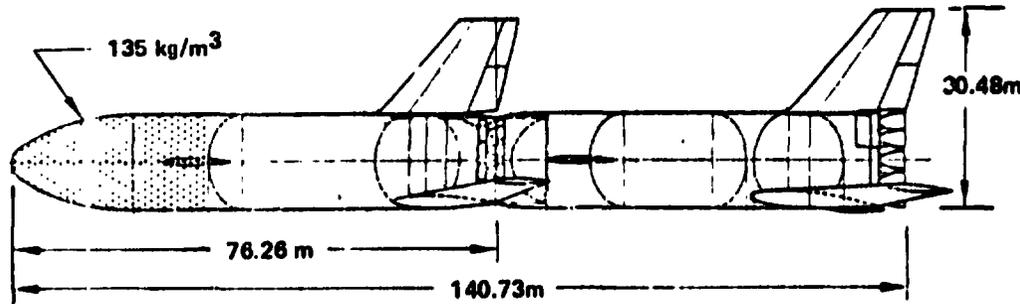

66 ORIGINAL PAGE IS OF POOR QUALITY

Figure 5.2-1 2-Stage Winged SPS Launch Vehicle

5.2.1 Vehicle Geometry

The overall geometry for the 2-stage winged vehicle is shown in Figure 5.2.1-1. All major body section locations and also surface geometry is noted on the figure. A 15.24 in body diameter was used on both stages. The first stage overall body length is 64.48 meters in the launch configuration and 69.98 meters in the reentry configuration. The booster aerosurface theoretical areas are as follows:

Wing	=	1033 m ²
Vertical	=	242 m ²
Canard	=	234 m ²

The upper stage overall length is 76.26 meters, including the cargo bay section. The upper stage aerosurface theoretical areas are as follows:

Wing	=	685 m ²
Vertical	=	226 m ²
Canard	=	219 m ²

The booster stage engines require three propellants due to the use of the LH₂ for cooling and as a result the following tank volumes including ullage space is provided:

RP-1 Tank Volume	=	1919 m ³
LO ₂ Tank Volume	=	3859 m ³
LH ₂ Tank Volume	=	910 m ³

The corresponding tank volumes for the upper stage are 1795 m³ for the LO₂ tank and 4830 m³ for the LH₂ tank.

PRECEDING PAGE BLANK NOT FILMED

FOLDOUT FRAME |

STA
0.600

STA
15.000

STA
38.65

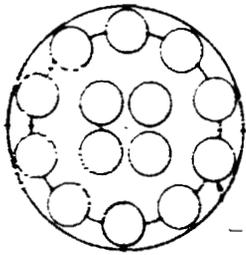

— IN STANDARD SSAME?
 E-113

SECT A-A

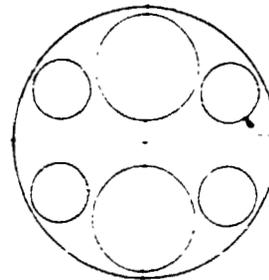
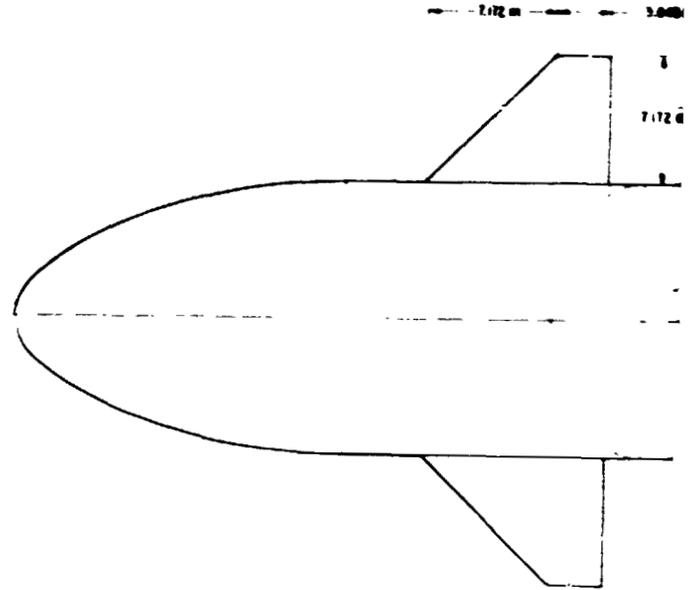
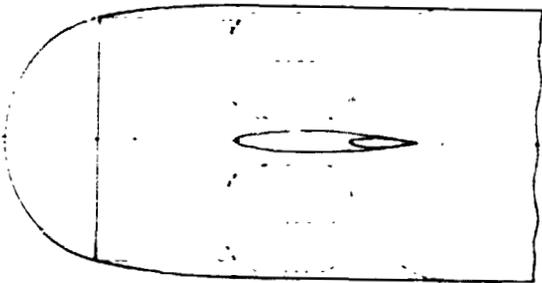

— LH₂ TANKS (6 PLACES)

SECT B-B

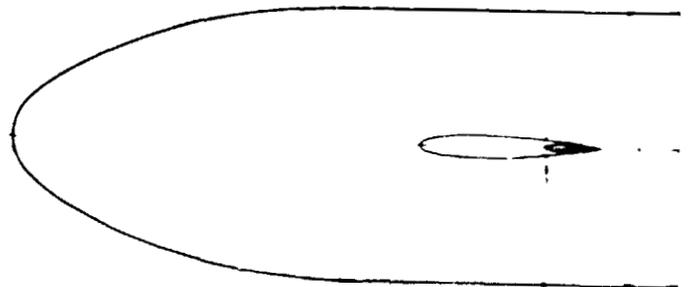

STA
9.250
REF

STA
99.277
REF

STA
111.363
REF

NOSE CONE EXTENDED - 1ST STAGE
RE ENTRY CONFIGURATION

ORIGINAL PAGE IS
OF POOR QUALITY

STA
10.000

STA
15.000

STA
34.050

STA
45.70

STA
51.097

STA 94 958

FOLDOUT FRAME 2

STA 15 080

STA 38 645

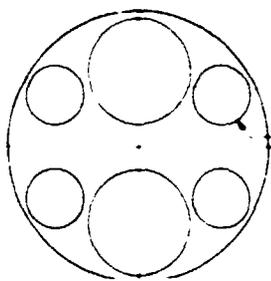
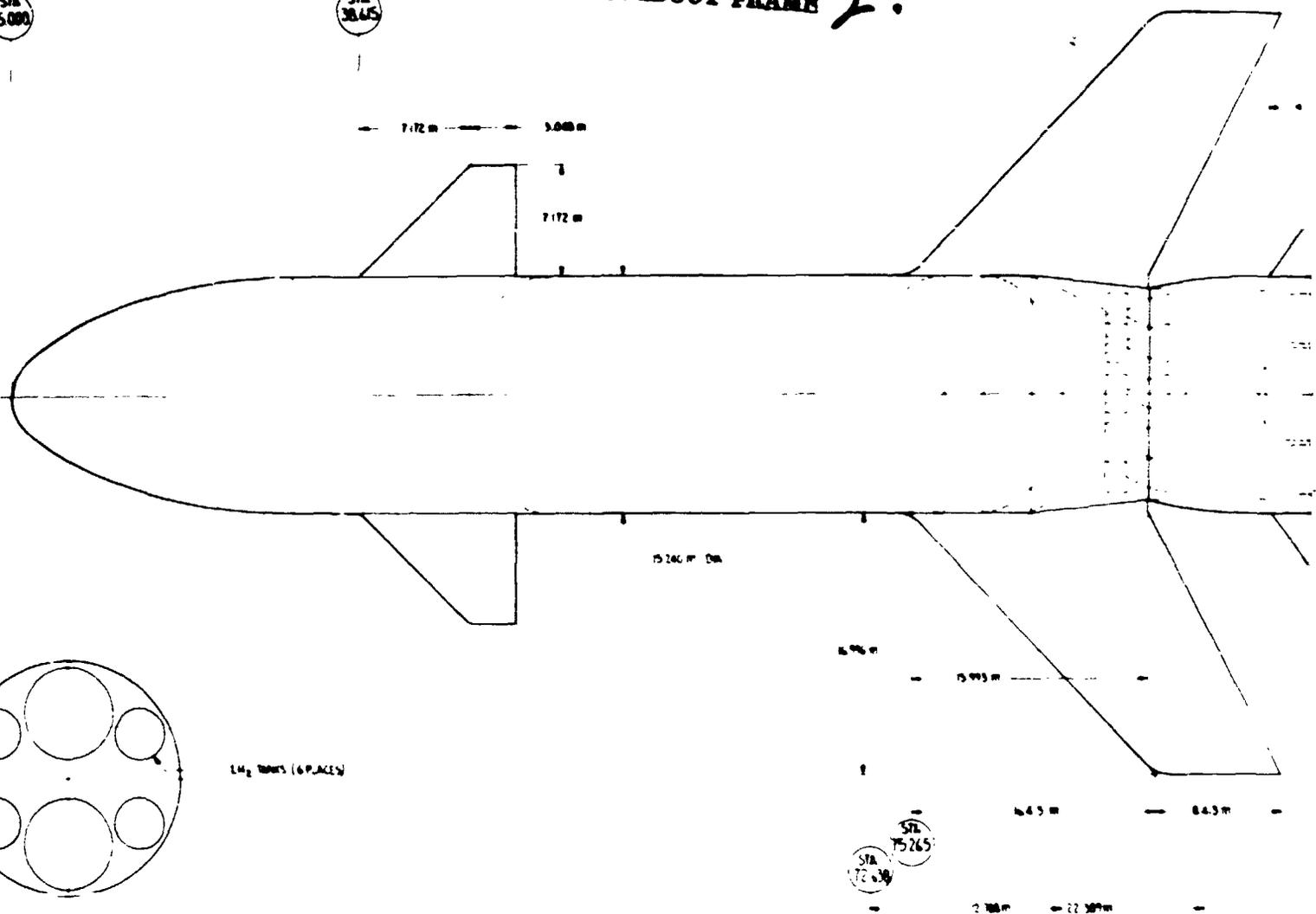

LM₂ TUBES (6 PLACES)

SECT B-B

STA 75 265

STA 72 638

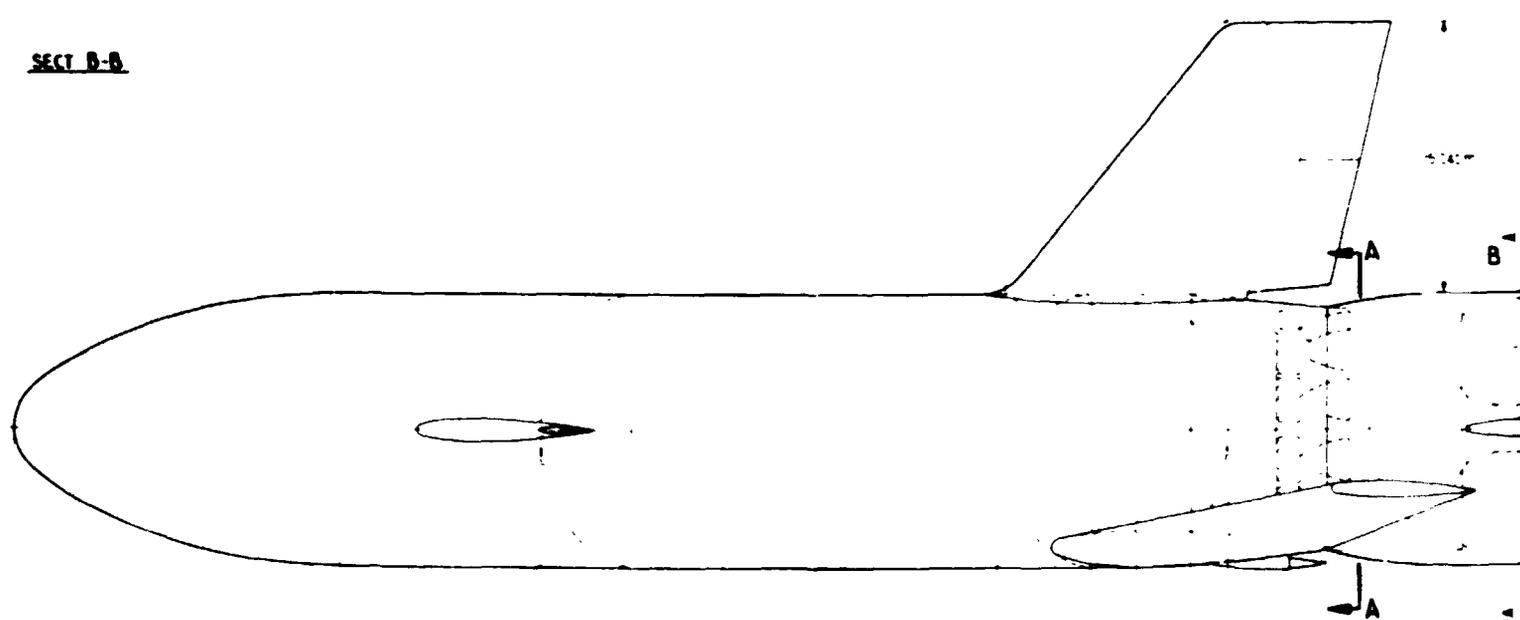

STA 15 000

STA 34 050

STA 45 70

STA 51 097

STA 72 191

STA 77 578

STA 83 383

STA 91 258

STA 94 958

JA 80 233

STA 85 620

ORIGINAL PAGE IS OF POOR QUALITY

FOLDOUT FRAME 3

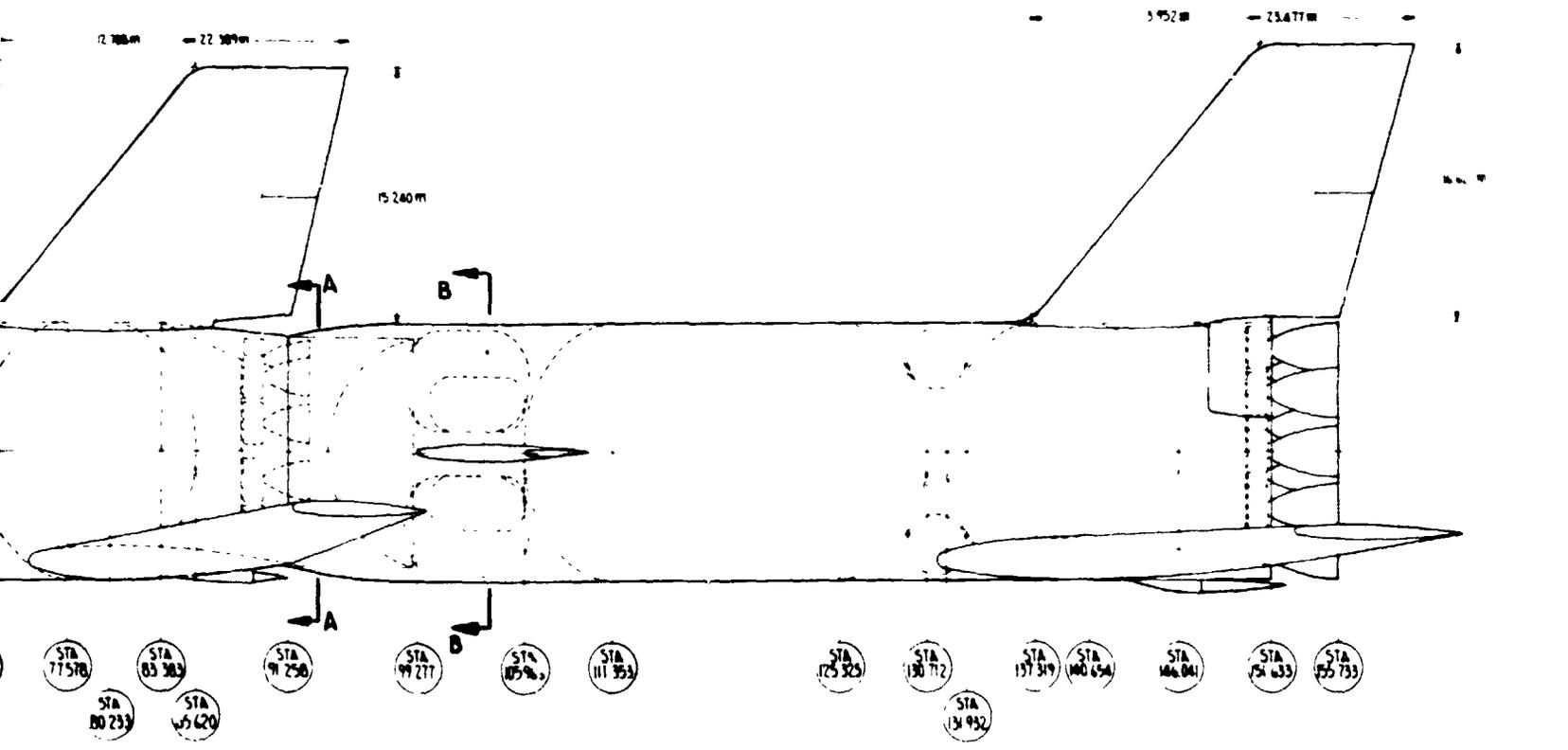
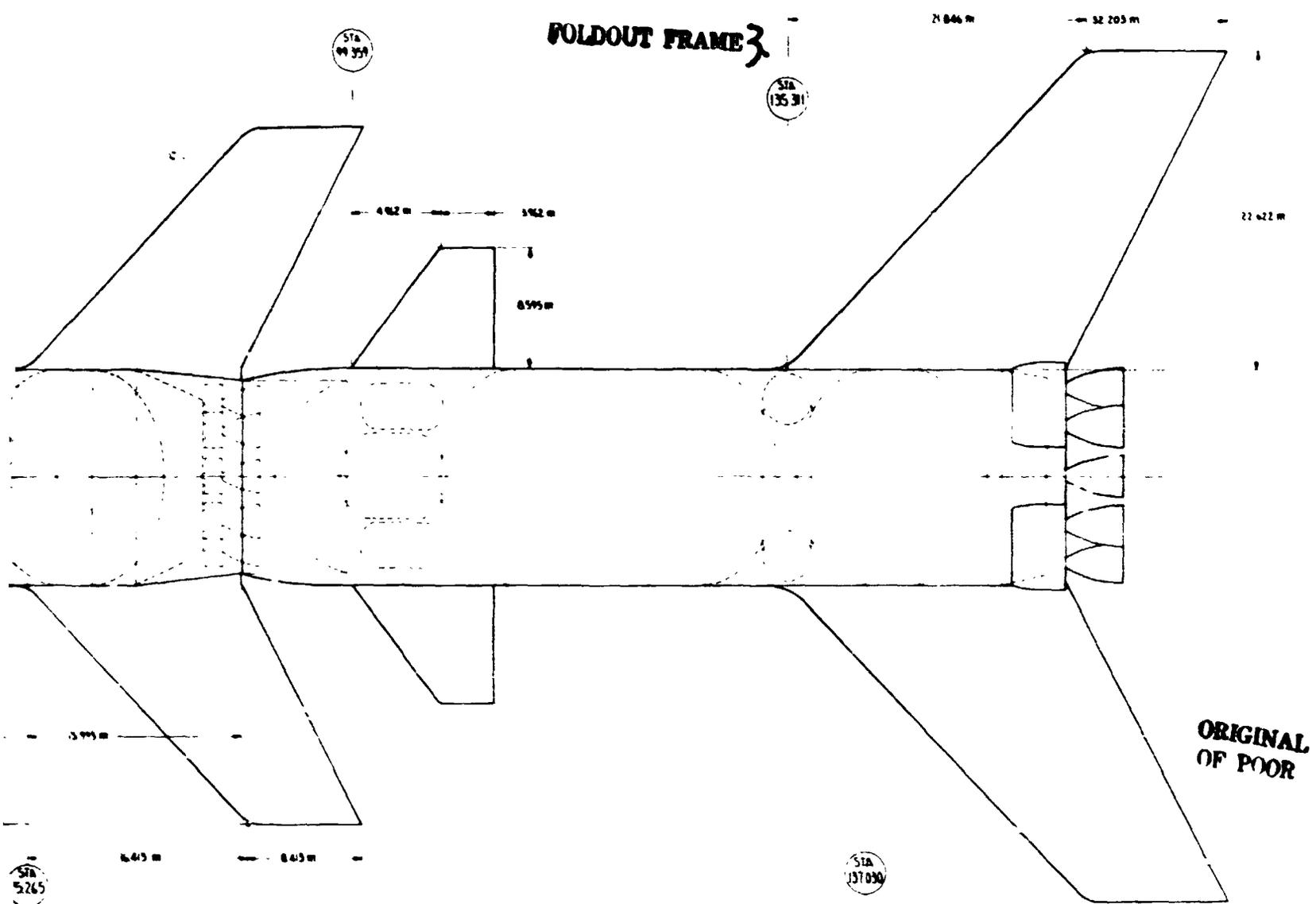

FOLDOUT FRAME 7A

D180-20689-5

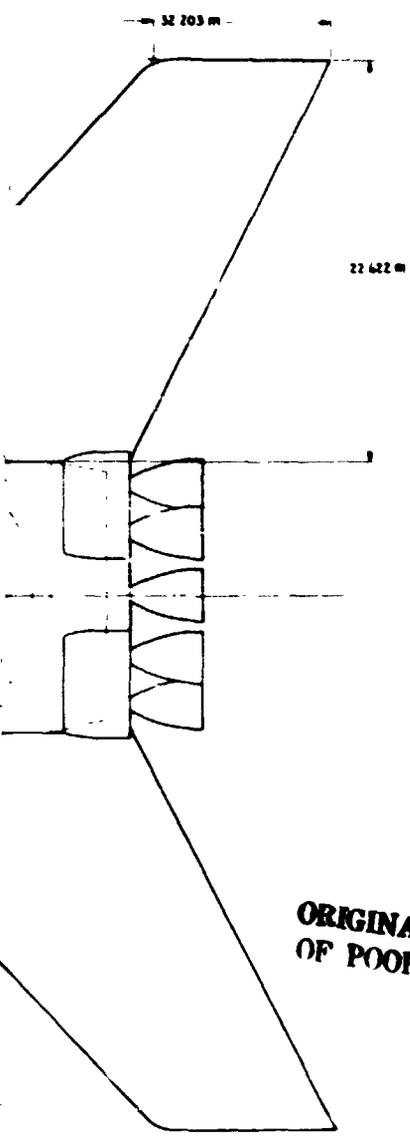

VEHICLE CHARACTERISTICS

- GLOW : $9.566 \cdot 10^7$ kg
- BLOW : $6.445 \cdot 10^7$ kg
- W_{H_2} : $5.676 \cdot 10^7$ kg
- ULOW : $2.759 \cdot 10^7$ kg
- W_{H_2} : $2.366 \cdot 10^7$ kg
- PAYLOAD : $0.381 \cdot 10^7$ kg
- TW @ LIFT-OFF : 130
- MAIN PROPULSION

STAGE	NUMBER / TYPE	THRUST / ENGINE (CONSUMERS)		ISP - SEC
		MP kg	MP kg	
1	16 / 16	1.275	1.000	260.1
2	16 / 16	1.000	0.800	255.2

ORIGINAL PAGE IS OF POOR QUALITY

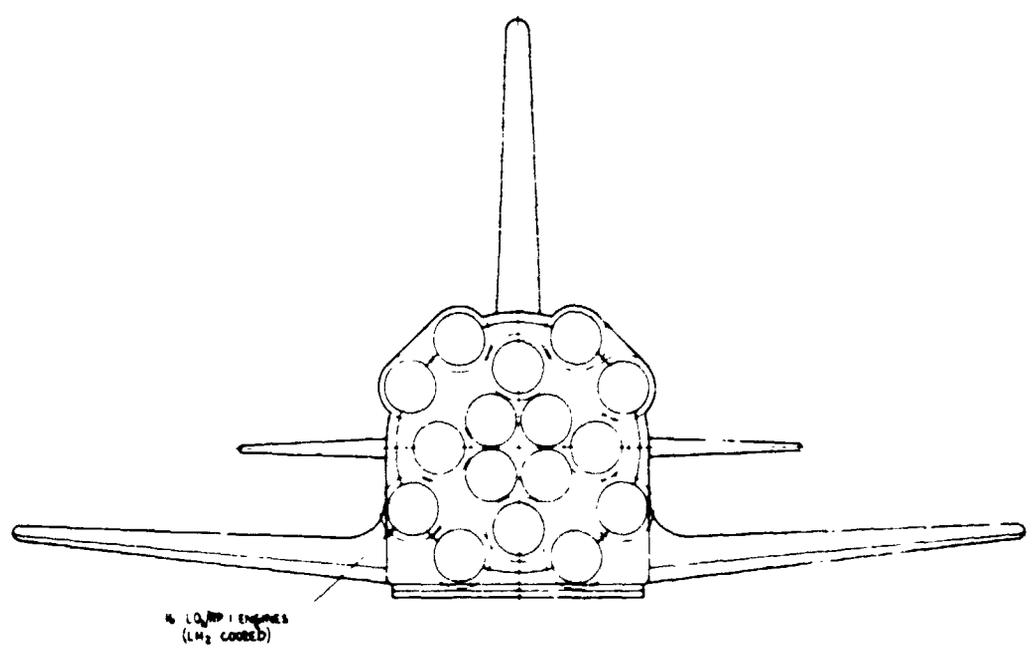
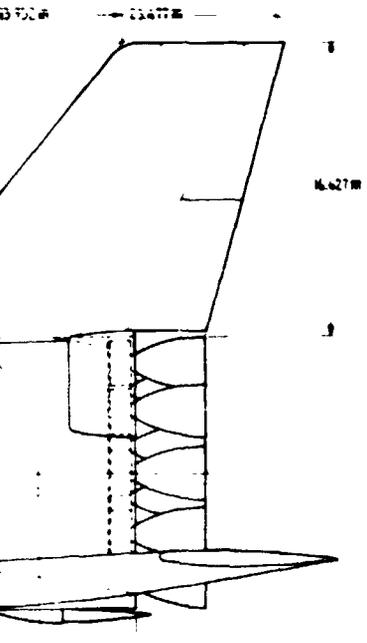

16 LQ/MP 1 ENGINES (LH₂ COOLED)

STA 146.041 STA 151.633 STA 155.723

Figure 5.2.1-1 2-Stage Winged Vehicle Configuration

ORIGINAL PAGE IS OF POOR QUALITY

5.2.2 Booster Stage

5.2.2.1 System Description

The booster stage of the 2-stage winged vehicle consists of the following subsystems:

- Ascent Propulsion
- Structures
- Thermal Protection
- Landing Gear
- Auxiliary Propulsion
- Prime Power
- Electrical Conversion and Distribution
- Hydraulic Conversion and Distribution
- Aerosurface Controls
- Avionics
- Environmental Control

Each of these subsystems will be discussed in the following sections including definition of the rationale for the mass and cost estimates.

5.2.2.1.1 Ascent Propulsion—The ascent propulsion subsystem consists of the main engines, accessories, gimbals, and the fuel and oxidizer systems. Main propulsion is provided by sixteen RP-1/LO₂/LH₂ gas generator cycle engines and the associated pressurization and propellant delivery systems. The following engine characteristics were used in the analysis:

Propellants	RP-1/LO ₂ /LH ₂
Thrust - Vacuum	8.275 x 10 ⁶ N
Chamber Pressure	29300 kpa
Mixture Ratio	2.9:1
Specific Impulse (S.L./Vac)	323.5/350.7 sec.

The total mass of the sixteen engines and the associated accessories and gimbals is 128090 kg.

The pressurization gases are heated GO₂ for the LO₂ tank and heated GH₂ for the RP-1 tank. Individual propellant delivery lines are provided to each engine. The total mass of the pressurization and delivery system is 39431 kg. Historical weight estimating relationships were used to determine the mass of the ascent propulsion system.

5.2.2.1.2 Structures—The booster structural subsystem consists of the body and aerosurface group. The body group consists of the nose section, LH₂ tanks, LO₂ tank, intertank, RP-1 tank, aft skirt, thrust structure and base heat shield. Included in the aerosurface group is the wing, vertical tail, canard and body flap. A preliminary sizing analysis was conducted to determine the individual structural element masses.

Nose Section—The nose section consists of the forward body shell portion and the movable nose cap and associated mechanism. The nose section experiences its maximum compressive load during the boost maximum acceleration condition. A peak compressive load of 34500 N/cm results in an average smeared body shell thickness of 1.04 cm in 6Al-4V titanium. The estimated mass of the nose section including the translating mechanism is 85236 kg.

LH₂ Tanks—The LH₂ tanks are all internal to the body shell and as such do not experience any of the external flight loads. A tank arrangement consisting of 6 tanks in the nose section cascading into a toroidal tank in the intertank region was selected to utilize the space available in the non-pressurized sections.

2219-T87 aluminum was selected as the tank material. The total mass of LH₂ tank including installation hardware is 6205 kg.

LO₂ Tank—An all welded 2219-T87 aluminum design. A maximum operating pressure of 512 kpa is anticipated. Peak proof test pressure of 682 kpa will provide adequate service life. The maximum smeared thickness of the cylindrical sidewall is 1.49 cm. The dome membrane thicknesses vary between 0.56 cm to 0.76 cm for the upper and 0.73 cm to 1.10 cm for the lower dome. The total mass of the LO₂ tank is 47032 kg.

Intertank—The intertank is approximately 12 meters long and constructed from 6Al-4V titanium. The intertank experiences its maximum compressive loading of 35730 N/cm during boost. An average smeared shell thickness of 1.08 cm is required and as a result the intertank mass is estimated to be 36321 kg including frames.

RP-1 Tank—The RP-1 tank is an all welded 2219-T87 aluminum pressure vessel with integral sidewall stiffening in the cylindrical section. A maximum operating pressure of 294 kpa is anticipated and results in a peak proof test pressure of 391 kpa for adequate service life. The maximum smeared sidewall thickness for the cylindrical section is 0.97 cm.

The dome membrane thickness varies between 0.35 cm to 0.41 cm for the upper and 0.39 cm to 0.63 cm for the lower dome. The total mass of the RP-1 tank is 13832 kg.

D180-20689-5

Aft Skirt—The aft skirt is fabricated from 6A1-4V titanium. A combination of the fueled pre-ignition and liftoff conditions result in the design loads. The compressive loading varies between 29400 N/cm and 38220 N/cm. A maximum smeared thickness of 1.16 cm is required and the total aft skirt mass is estimated to be 44826 kg including frames.

Thrust Structure—The thrust structure consists of the major internal beam structure and frames which provide the load introduction structure for the rocket engine thrust loads. A combination graphite epoxy/titanium structure is the selected design concept. The maximum thrust load is experienced at booster burnout. Three (3) meter deep beams in an intersecting pattern to provide lateral stiffness were incorporated. The total mass of the thrust structure is estimated to be 37590 kg.

Base Heat Shield—The base heat shield consists of the individual panels and their support structure which mount to the thrust beams and aft skirt structure. Titanium (6AL-4V) is the material selected due to its good thermal performance. The total mass of the base heat shield structure is 4696 kg.

Wing—The wing is constructed from 7075-T73 aluminum box structure and 6A1-4V titanium leading and trailing edges. A heat sink design has been incorporated and the additional thicknesses to satisfy the heat sink requirements have been included in the structure mass. A constant $t/c = 12\%$ was assumed. The 2.5 'g' subsonic maneuver along with the entry platform loading have been used to size the wing structure. The mass of the major wing components are as follows:

Structural Box =	58968 kg
Elevons, Trailing and Leading Edges	= <u>12973 kg</u>
Total	= 71941 kg

Including in these masses are heat sink penalties of 1252 kg on the box and 1470 kg on the leading and trailing edge structure.

Vertical Tail—The vertical tail was sized for the $q\beta$ condition during boost. A $q\beta$ max of 187.7 kpa is estimated. The box structure is 7075-T73 aluminum and the remaining tail structure is 6A1-4V titanium. The total mass of the vertical tail is estimated to be 8800 kg.

Canard—The canard was sized for the $q\alpha$ condition during boost of 187.7 kpa. Included in the canard is the exposed surfaces, spindle and carry-through structure. The total mass of the canard structure is estimated to be 5625 kg.

D180-20689-5

Body Flap—The constant chord body flap protects the main engines during entry and provides a control surface during unpowered flight. The estimated mass is 3969 kg.

5.2.2.1.3 Thermal Protection—The thermal protection system (TPS) for the winged booster is primarily the base heat shield since the heat sink penalties are included in the structure element mass. Reusable Surface Insulation is the TPS concept selected for the base heat shield. An average insulation density of 13.2 kg/m^2 was selected and the total mass of the system is 2405 kg.

5.2.2.1.4 Landing Gear—The landing gear mass estimates are the same as those reported in the NASA, JSC report EDIN EX-338-76. These values were confirmed by using inhouse weight estimating relationships. The nose and main landing gear masses are 2037 kg and 23003 kg, respectively.

5.2.2.1.5 Other Subsystems—The remaining subsystem masses have been estimated using historical or Shuttle predicted weights. These subsystems include auxiliary propulsion (RCS), prime power, electric conversion and distribution, hydraulic conversion and distribution, aerosurface controls, avionics, and environmental control.

Auxiliary Propulsion—The reaction control system (RCS) is required for orbit trim and also stage orientation prior to entry and control during entry. The subsystem dry mass is 745 kg.

Prime power—The major electrical power sources on the booster are both batteries and auxiliary power units. The prime power subsystem mass is estimated to be 3039 kg.

Electric Conversion and Distribution—The power conditioning and cabling elements are included in this category. The estimated mass is 907 kg.

Hydraulic Conversion and Distribution—The hydraulic system for the thrust vector control and actuation systems is included in this category. The estimated mass is 7584 kg.

Aerosurface Controls—The control system for the aerodynamic surfaces including actuators, fittings, etc. is included in this category. The control system individual element mass estimate was developed using historical relationships as follows:

Element	Proportional Factor	Mass
Wing Surface Controls	Reference area	3937 kg
Vertical Tail Surface Controls	Exposed area	794 kg
Canard Surface Controls	Exposed area	431 kg
Body Flap Surface Controls	Total Area	<u>544 kg</u>
	Total =	5706 kg

Avionics—The avionics subsystem includes the guidance and navigation, flight data management and the communication system elements. The total mass of the avionics subsystem is estimated to be 2431 kg.

Environmental Control—The on-board environmental control system is primarily associated with the thermal conditioning of the avionics equipment and the purge requirements for the main engines after shutdown. The subsystem mass is estimated to be 2610 kg.

5.2.2.2 Booster Mass Characteristics

The booster mass characteristics reflect the results of the preliminary structural sizing analysis and incorporation of historical weight estimating relationships. Element masses have been identified and described in Section 5.2.2.1, System Description. The summarized booster mass statement is shown in Table 5.2.2-1. A 10% mass growth allowance has been included on all dry mass elements. The total booster stage dry mass is estimated to be 641770 kg. The major portions of the dry mass are the structural (57%) and ascent propulsion (26%) subsystems.

The fluids inventory is noted on Table 5.2.2-1. Residual and unusable fluids and gases are the major inert item in the fluid inventory. The residual mass estimate reflects an open loop propellant utilization system. The booster inert mass is 738 120 kg.

5.2.2.3 Booster Cost Estimate

The DDT&E and initial production unit cost for the booster of the two stage winged vehicle are shown on Table 5.2.2-2. The basic work breakdown structure (WBS) is identical to that shown in Figure 5.1.3-1 for the ballistic booster. A DDT&E cost of \$5.2B includes the basic stage design and development (\$1.62B), system test (\$2.17B), tooling, etc. The equivalent of 2.5 vehicles for ground test and 2 for flight test are included in system test category.

The theoretical first unit (TFU) production cost of \$560.5M is proportioned as follows:

Structure	35%
Ascent Propulsion	23%
Avionics	8%
GSE	10%
Program Management	8%
Other	16%

Approximately 2/3 of the initial production cost is attributable to the structures, propulsion and avionics subsystems

An estimated \$50M has been included in DDT&E cost for the booster portion of flight test operations.

Table 5.2.2-1 Winged Booster Stage Mass Stagement

SPS 657

STAGE ELEMENT	10 ³ kg
STRUCTURE	366.07
BODY	(275.74)
AEROSURFACES	(90.33)
TPS	2.40
LANDING GEAR	25.04
ASCENT PROPULSION	167.52
AUXILIARY PROPULSION	0.74
PRIME POWER	3.04
ELECTRIC CONVERSION & DISTRIBUTION	0.91
HYDRAULIC CONVERSION & DISTRIBUTION	7.58
AEROSURFACE CONTROLS	5.71
AVIONICS	1.81
ECS	2.61
GROWTH	58.34
	<hr/>
DRY MASS	641.77
RESIDUALS & UNUSABLES	90.00
USABLE RCS & RESERVES	6.35
	<hr/>
INERT MASS	738.12

	10³kg
	<hr/>
ASCENT PROPELLANT	5896.4
INERT MASS	738.1
	<hr/>
BLOW	3434.5

Table 5.2.2-2 Winged Booster DDT&E and 1st Unit Production Costs

NO	NAME	SUB ELEMENT TO	METHOD	SOUR- CES	BLEND FACTORS	SUPT FROM	QTY %	MOD %	MOD CNPLX	NUMBER	LRN	CDST (000)
1	TOTAL PROGRAM	0	DDT&E SUBS	0	0.00	0	0	0	0.0			5,202,075
			UNIT SUBS	0	0.00	0				0	0	560,477
2	PRG INTER & MANAG	1	DDT&E FACTOR	3	0.10	0	0	0	0.0			228,727
			UNIT FACTOR	3	0.10	0				0	0	43,845
3	WING/WING BOOSTER	1	DDT&E SUBS	0	0.00	0	0	0	0.0			4,923,351
			UNIT SUBS	0	0.00	0				0	0	516,632
4	FLT VEH 1ST STAGE	3	DDT&E SUBS	0	0.00	0	0	0	0.0			4,923,351
			UNIT SUBS	0	0.00	0				0	0	516,632
5	FLT VEH DFO	4	DDT&E SUBS	0	0.00	0	0	0	0.0			1,617,192
			UNIT SUBS	0	0.00	0				0	0	436,255
6	STRUCTURE	5	DDT&E SUBS	0	0.00	0	0	0	0.0			554,443
			UNIT SUBS	0	0.00	0				0	0	158,497
7	BODY GROUP (INC TPS)	6	DDT&E SUBS	0	0.00	0	0	0	0.0			402,845
			UNIT SUBS	0	0.00	0				0	0	142,164
8	NOSE 18443 LBS	7	DDT&E CER	3	1.00	28	0	0	0.0			15,372
			UNIT CER	37	1.00	54				1	25	5,843

77

D180-20689-5

Table 5.2.2-2 (Continued)

9 FWD SKIRT 48976 LBS	7 DDTCE CER	9	1.00	28	0	0	0.0		36,501
	UNIT CER	37	1.00	54				1 85	13,757
10 AFT SKIRT 106700 LBS	7 DDTCE CER	9	1.00	28	0	0	0.0		74,364
	UNIT CER	37	1.00	54				1 85	27,677
11 THRUST STRUCTURE 91157 LBS	7 DDTCE CER	9	1.00	28	0	0	0.0		63,925
	UNIT CER	37	1.00	54				1 85	23,718
12 LO2 TANK 114056 LBS	7 DDTCE CER	62	1.00	28	0	0	0.0		55,834
	UNIT CER	63	1.00	54				1 85	17,467
13 FUEL TANK 33543 LBS	7 DDTCE CER	62	1.00	28	0	0	0.0		18,830
	UNIT CER	63	1.00	54				1 85	6,133
14 LH2 TANK 1504 LBS	0 DDTCE CER	62	1.00	29	0	0	0.0		1,287
	UNIT CER	63	1.00	54				1 85	431
15 BASE STRUCTURE 11388 LBS	7 DDTCE CER	9	1.00	28	0	0	0.0		10,063
	UNIT CER	37	1.00	54				1 85	3,829

Table 5.2.2-2 (Continued)

16 INTERSTAGE 139284	LBS	7 DDTCE CER	62	1.00	28	0	0	0.0		66,747
		UNIT CER	63	1.00	54				1 85	20,722
17 INTERTANK 88081	LBS	7 DDTCE CER	3	1.00	28	0	0	0.0		61,606
		UNIT CER	37	1.00	54				1 85	23,014
18 WING GROUP 174460	LBS	6 DDTCE CER	3	1.00	28	0	0	0.0		113,641
		UNIT CER	37	1.00	54				1 85	41,901
19 BODY FLAP 9625	LBS	6 DDTCE CER	3	1.00	28	0	0	0.0		8,686
		UNIT CER	37	1.00	54				1 85	3,304
20 TAIL GROUP		6 DDTCE SUBS	0	0.00	0	0	0	0.0		29,270
		UNIT SUBS	0	0.00	0				0 0	11,126
21 CANARD 13640	LBS	20 DDTCE CER	3	1.00	28	0	0	0.0		12,789
		UNIT CER	37	1.00	54				1 85	4,485
22 VERTICAL 21340	LBS	20 DDTCE CER	3	1.00	28	0	0	0.0		17,481
		UNIT CER	37	1.00	54				1 85	6,641
		5 DDTCE SUBS	0	0.00	0	0	0	0.0		10,132
		UNIT SUBS	0	0.00	0				0 0	5,260

79

D180-20689-5

ORIGINAL PAGE IS
OF POOR QUALITY

Table 5.2.2-2 (Continued)

24 BODY ENTRY TPS 1 SQF	0	DDTLE CER	64	2.00	28	0	0	0.0		23
		UNIT CER	65	2.00	54				1 85	10
25 FLAME SHIELD 1964 SQF	23	DDTCE CER	64	2.00	28	0	0	0.0		5.913
		UNIT CER	65	2.00	54				1 85	3.056
26 LOZ TANK INSU 1 SQF	0	DDTCE CER	64	2.00	28	0	0	0.0		23
		UNIT CER	65	2.00	54				1 85	10
27 INTER INSU 1 SQF	0	DDTCE CER	64	2.00	28	0	0	0.0		23
		UNIT CER	65	2.00	54				1 85	10
28 FUEL TANK INSU 6415 SQF	0	DDTCE CER	64	1.00	28	0	0	0.0		8.710
		UNIT CER	65	1.00	54				1 85	4.424
29 WING TPS 1 SQF	23	DDTLE CER	64	2.00	28	0	0	0.0		23
		UNIT CER	65	2.00	54				1 85	10
30 CANARD TPS 1 SQF	23	DDTCE CER	64	2.00	28	0	0	0.0		23
		UNIT CER	65	2.00	54				1 85	10

80

ORIGINAL PAGE IS
OF POOR QUALITY

D180-20689-5

Table 5.2.2-2 (Continued)

31 VERT TAIL TPS 1 SQF	27 DOTCE CER	64	2.00	28	0	0	0.0		23
	UNIT CER	65	2.00	54				1 85	10
32 BODY FLAP TPS 1250 SQF	23 DOTCE CER	64	2.00	28	0	0	0.0		4,147
	UNIT CER	65	2.00	54				1 85	2,173
33 LANDING SYSTEM	5 DOTCE SUBS	0	0.00	0	0	0	0.0		145,834
	UNIT SUBS	0	0.00	0				0 0	17,261
34 NOSE GEAR 4939 LBS	33 DOTCE CER	6	1.00	28	0	0	0.0		17,252
	UNIT CER	37	1.00	54				1 85	1,840
35 MAIN GEAR 55784 LBS	33 DOTCE CER	6	1.00	28	0	0	0.0		128,581
	UNIT CER	37	1.00	54				1 85	15,420
36 ASCENT PROP	5 DOTCE SUBS	0	0.00	0	0	0	0.0		683,943
	UNIT SUBS	0	0.00	0				0 0	129,412
37 MAIN ENGINES 1.86E6 THRUST	36 DOTCE CER	26	1.00	28	0	0	0.0		617,721
	UNIT CER	53	1.00	54				16 90	112,685
38 ENGINE ACCES 3056 LBS	36 DOTCE CER	6	1.00	28	0	0	0.0		11,649
	UNIT CER	40	1.00	54				16 90	8,055

Table 5.2.2-2 (Continued)

39 PROP DELIVERY 69937 LBS	36 DDTLE CER	4	1.00	28	0	0	0.0		34,521
	UNIT CER	40	1.00	54				1 85	5,770
40 PRESS SYS 25706 LBS	36 DDTLE CER	4	1.00	28	0	0	0.0		20,552
	UNIT CER	40	1.00	54				1 85	2,897
41 UX PROP SYS	5 DDTLE SUBS	0	0.00	0	0	0	0.0		6,775
	UNIT SUBS	0	0.00	0				0 0	2,959
42 PROP RCS	41 DDTLE SUBS	0	0.00	0	0	0	0.0		6,775
	UNIT SUBS	0	0.00	0				0 0	2,959
43 RCS ENGINE 668 LBS	42 DDTLE CER	7	1.00	28	50	0	0.0		3,730
	UNIT CER	39	1.00	54				1 85	2,561
44 RCS PRESSLINES 343 LBS	42 DDTLE CER	4	1.00	28	0	0	0.0		2,288
	UNIT CER	40	1.00	54				1 85	148
45 RCS TANKS 795 LBS	42 DDTLE CER	62	1.00	28	0	0	0.0		756
	UNIT CER	63	1.00	54				1 85	249
46 PROP OMS	0 DDTLE SUBS	0	0.00	0	0	0	0.0		149
	UNIT SUBS	0	0.00	0				0 0	4

Table 5.2.2-2 (Continued)

47 ENGINES	46 DDTCE S	0	0.00	0	0	0	0.0		0
	UNIT S	0	0.00	0				2 90	0
48 PRESSELINES 1 LBS	46 DDTCE CER	4	1.00	28	0	0	0.0		339
	UNIT CER	40	1.00	54				1 85	2
49 FUEL TANK 1 LBS	46 DDTCE CER	62	1.00	28	0	0	0.0		5
	UNIT CER	63	1.00	54				1 85	0
50 LO2 TANK 1 LBS	46 DDTCE CER	62	1.00	28	0	0	0.0		5
	UNIT CER	63	1.00	54				1 85	0
51 PRIME POWER	5 DDTCE SUBS	0	0.00	0	0	0	0.0		22,525
	UNIT SUBS	0	0.00	0				0 0	18,834
52 APU 1842 LBS	51 DDTCE CER	7	1.00	28	0	0	0.0		14,810
	UNIT CER	39	1.00	54				1 85	6,365
53 BATTERIES 5528 LBS	51 DDTCE CER	16	1.00	28	0	0	0.0		7,714
	UNIT CER	47	1.00	54				1 85	12,469
54 ELEC CONV/DIS	5 DDTCE SUBS	0	0.00	0	0	0	0.0		6,787
	UNIT SUBS	0	0.00	0				0 0	6,308

33

ORIGINAL PAGE IS
OF POOR QUALITY

D180-20689-5

Table 5.2.2-2 (Continued)

55 CONV EQU 440	LBS	54 DDTCE CF1	18	1.00	28	0	0	0.0		1,581
		UNIT CER	49	1.00	54				1 85	1,614
56 CONTROLS 286	LBS	54 DDTCE CER	18	1.00	28	0	0	0.0		1,110
		UNIT CER	49	1.00	54				1 85	1,100
57 CABLES AND CONTROLS 1474	LBS	54 DDTCE CER	15	1.00	28	0	0	0.0		4,095
		UNIT CER	47	1.00	54				1 85	3,593
58 AVIONICS		5 DDTCE SUBS	0	0.00	0	0	0	0.0		70,622
		UNIT SUBS	0	0.00	0				0 0	46,463
59 CONTROL 1963	LBS	58 DDTCE CER	17	1.00	28	0	0	0.0		63,390
		UNIT CER	48	1.00	54				1 85	38,607
60 COMMUNICATIONS .16	LBS	58 DDTCE CER	18	1.00	28	0	0	0.0		1,804
		UNIT CER	49	1.00	54				1 85	1,860
61 DATA HANDLING 1921	LBS	58 DDTCE CER	18	1.00	28	0	0	0.0		5,426
		UNIT CER	49	1.00	54				1 85	5,994
62 ECS		5 DDTCE SUBS	0	0.00	0	0	0	0.0		16,632
		UNIT SUBS	0	0.00	0				0 0	6,309

Table 5.2.2-2 (Continued)

63 TANK PURGE 2867 LBS	62 DDTCE CER	4	1.00	28	0	0	0.0		6,670
	UNIT CER	40	1.00	54				1 85	640
64 COMP BAYS 3462 LBS	62 DDTCE CER	23	1.00	28	0	0	0.0		9,962
	UNIT CER	41	1.00	54				1 85	5,669
65 PAYLOAD SYS 1 LBS	0 DDTCE CER	6	1.00	28	0	0	0.0		27
	UNIT CER	37	1.00	54				1 85	1
66 HYDRAULIC SYSTEM 18392 LBS	5 DDTCE CER	6	1.00	28	0	0	0.0		51,049
	UNIT CER	40	1.00	54				1 85	2,301
67 AERD SURF CONT	5 DDTCE SUBS	0	0.00	0	0	0	0.0		48,446
	UNIT SUBS	0	0.00	0				0 0	2,647
68 WING SURF CONT 9548 LBS	67 DDTCE CER	6	1.00	28	0	0	0.0		29,675
	UNIT CER	40	1.00	54				1 85	1,465
69 CANARD SURF CONT 1045 LBS	67 DDTCE CER	6	1.00	28	0	0	0.0		4,881
	UNIT CER	40	1.00	54				1 85	319
70 VERT TAIL CONT 1925 LBS	67 DDTCE CER	6	1.00	28	0	0	0.0		7,997
	UNIT CER	40	1.00	54				1 85	486

85

ORIGINAL PAGE IS
OF POOR QUALITY

D180-20689-5

Table 5.2.2-2 (Continued)

71 BODY FLAP CONT 1,20 LBS	4	DDTCE CER	6	1.00	28	0	0	0.0		5,892
		UNIT CER	40	1.00	54				1 85	375
72 ASSY 'D	4	DDTCE N/A	0	0.00	0	0	0	0.0		0
		UNIT CER*	5	0.00	0				0 0	29,892
			60	0.00						
73 TOOLING	4	DDTCE FACTOR	5	0.50	0	0	0	0.0		918,037
		UNIT N/A	0	0.00	0				0 0	0
74 SYSTEM TEST	4	DDTCE SUBS	0	0.00	0	0	0	0.0		2,167,859
		UNIT N/A	0	0.00	0				0 0	0
75 SYS TEST LABOR	74	DDTCE CER*	5	0.00	0	0	0	0.0		204,702
			30	0.00						
		UNIT N/A	0	0.00	0				0 0	0
76 CR TEST HOME	74	DDTCE FAC UN	5	2.50	0	0	0	0.0		1,090,639
		UNIT N/A	0	0.00	0				0 0	0
77 FL* TEST HOME	74	DDTCE FAC UN	5	2.00	0	0	0	0.0		872,511
		UNIT N/A	0	0.00	0				0 0	0
78 SELL	4	DDTCE CER*	5	0.00	0	0	0	0.0		80,317
			29	0.00						
		UNIT N/A	0	0.00	0				0 0	0

D180-20689-5

Table 5.2.2-2 (Continued)

79	FLT VEH DCLT	0	DDTCE FACTOR	5	1.00	0	0	0	0.0	0
				78	1.00					
				75	1.00					
			UNIT N/A	0	0.00	0		0	0	0
80	SOFTWARE ENGR	4	DDTCE CER*	79	0.00	0	0	0	0.0	100.722
				33	0.00					
			UNIT N/A	0	0.00	0		0	0	0
81	GSE	4	DDTCE CER*	5	0.00	0	0	0	0.0	39.239
				56	0.00					
			UNIT CER*	5	0.00	0		0	0	56.424
				57	0.00					
82	FLT TEST OPS	1	DDTCE	9	0.00	0	0	0	0.0	50.000
			UNIT N/A	0	0.00	0		0	0	0
83		0	DDTCE SUBS	0	0.00	0	0	0	0.0	0
			UNIT SUBS	0	0.00	0		0	0	0
84		0	DDTCE SUBS	0	0.00	0	0	0	0.0	0
			UNIT SUBS	0	0.00	0		0	0	0
85		0	DDTCE SUBS	0	0.00	0	0	0	0.0	0
			UNIT SUBS	0	0.00	0		0	0	0
86		0	DDTCE SUBS	0	0.00	0	0	0	0.0	0
			UNIT SUBS	0	0.00	0		0	0	0

D180-20689-5

5.2.3 Upper Stage

5.2.3.1 System Description

The upper stage of the 2-stage winged vehicle consists of the following subsystems:

- Ascent Propulsion
- Structures
- Thermal Protection
- Landing Gear
- Auxiliary Propulsion
- Prime Power
- Electrical Conversion and Distribution
- Hydraulic Conversion and Distribution
- Aerosurface Controls
- Avionics
- Environmental Control

Each of these subsystems will be discussed in the following sections including definition of the rationale for the mass and cost estimates.

5.2.3.1.1 Ascent Propulsion—The ascent propulsion subsystem consists of the main engines, accessories, gimbals, and fuel and oxidizer systems. Main propulsion is provided by fourteen (14) standard SSME's ($\epsilon = 77.5$). The following engine characteristics were used in the analysis:

Propellants	LH ₂ /LO ₂
Thrust-Vacuum	$2.990 \times 10^6 \text{N}$
Chamber Pressure	20685 kpa
Mixture Ratio	6:1
Specific Impulse - (S.L./Vac.)	363.2/455.2 sec.
Total Flow Rate/Engine	468.4 kg/sec

The total mass of the fourteen engines and the associated accessories and gimbals is 45161 kg. Pressurization system is heated GO₂ for the LO₂ tank and heated GH₂ for the LH₂ tank. Individual propellant delivery lines are provided to each engine. The total mass of the pressurization and delivery system is 7069 kg.

5.2.3.1.2 Structures

The upper stage structural subsystem consists of the body and aerosurface group. The body group consists of the nose/payload section, forward skirt, LH₂ tank, LO₂ tank, aft skirt, thrust structure and base heat shield. Included in the aerosurface group is the wing, vertical tail, canard and body flap. A preliminary sizing analysis was conducted to determine the individual structural element mass.

Nose/Payload Section—The ogive shaped nose section consists of the forward body shell and the payload access doors and mechanisms. A maximum compressive load of 4270 N/cm is anticipated and results in requiring an average smeared body shell thickness of 0.25 cm in 6Al-4V titanium. The estimated mass of the nose section is 10889 kg.

Forward Skirt—The cylindrical shaped forward skirt is a 6Al-4V titanium structure. A maximum compressive load of 5020 N/cm is anticipated and results in an average smeared body shell thickness of 0.16 cm. The estimated mass of the forward skirt is 7592 kg.

LH₂ Tank—An all-welded 2219-T87 aluminum design was selected for the LH₂ Tank. The aft dome, common with the LO₂ tank, is accounted for as a part of the LO₂ tank. A maximum operating pressure of 231 kpa occurs during the maximum acceleration condition. A proof pressure of 307 kpa will provide adequate service life. The average cylindrical sidewall thickness is 0.85 cm and the upper dome membrane thickness varies between 0.35 cm and 0.50 cm. The total mass of the LH₂ tank is 42636 kg.

LO₂ Tank—The LO₂ tank is also an all-welded 2219-T87 aluminum design. A maximum operating pressure of 677 kpa occurs during the maximum acceleration condition. A proof pressure of 901 kpa will provide adequate service life. The average cylindrical sidewall thickness of 2.08 cm results from the proof test condition. The upper common bulkhead smeared thickness varies between 1.42 cm and 1.87 cm. The lower dome thickness varies between 0.98 cm and 1.46 cm. The total mass of the LO₂ tank is 37258 kg.

Aft Skirt—The aft skirt is fabricated from 6Al-4V titanium. A maximum compressive loading of 34420 N/cm is expected during the maximum acceleration condition. The average cylindrical body shell smeared thickness is 1.04 cm and the total mass of the aft skirt is 32204 kg.

Thrust Structure—The thrust structure consists of an internal cone with thrust posts at each engine location and a major frame at the engine gimbal interface plane. A combination graphite epoxy-6Al-4V titanium structure is the design concept. The average compressive loading is 9930 N/cm and the resulting thickness is 0.30 cm. In addition, 14 thrust posts with an average cross section area of 39.4 cm² are required. The total mass of the thrust structure is 5337 kg.

D180-20689-5

Base Heat Shield—The base heat shield consists of the individual panels and their support structure. Titanium (6Al-4V) is the fabrication material selected. The individual panels will provide support for the thermal protection system. The total mass of the base heat shield structure is 4696 kg.

Wing—The wing is constructed from 7075-T73 aluminum alloy. A constant 12% t/c was selected. The 2.5g subsonic maneuver along with the entry platform loading have been used to size the wing structure. The mass of the major wing components are as follows:

Structural Box	=	35607 kg
Elevons, Trailing and Leading Edges	=	<u>7711 kg</u>
Total	=	43318 kg

Vertical Tail—The vertical tail was sized for the $q\beta$ condition during boost. A $q\beta$ max. of 187.7 kpa is estimated. The structural material is 7075-T73 aluminum and the total mass is estimated to be 6804 kg.

Canard—The canard was sized for the $q\alpha$ condition during boost of 187.7 kpa. Included in the canard structure is the exposed surface, spindle and carry-through structure. The total mass of the canard structure is estimated to be 4445 kg.

Body Flap—The constant chord body flap protects the main engines during entry and provides a control surface during unpowered flight. The estimated mass of the body flap is 3969 kg.

5.2.3.1.3 Thermal Protection—The thermal protection system (TPS) consists of both low and high temperature systems. The low temperature TPS for the LH₂ tank is a reusable internal foam. Reusable Surface Insulation (RSI) has been selected for the external exposed areas and the base heat shield. The total mass of the TPS is 48778 kg.

5.2.3.1.4 Landing Gear—The landing gear mass estimates are the same of those reported in NASA/JSC report EDIN EX-338-76. These values were within the range of predicted landing gear mass based on total landed mass. The nose and main landing gear masses are 1104 kg and 12450 kg, respectively.

5.2.3.1.5 Other Subsystems—The remaining subsystem masses have been estimated using historical or Shuttle predicted weights. These subsystems include auxiliary propulsion (OMS and RCS), prime power, electric conversion and distribution, hydraulic conversion and distribution, aero-surface controls, avionics, and environmental control.

D180-20689-5

Auxiliary Propulsion—The auxiliary propulsion system consists of the orbit maneuvering (OMS) and reaction control systems (RCS). The OMS consists of two (2) RL-10 engines and associated pressurization, delivery and propellant storage (tankage) elements. A total dry mass of 1551 kg is estimated for the orbit maneuvering system.

The reaction control system consists of four sets of thrusters (4/set) and the associated pressurization, delivery and propellant storage hardware. Modified Shuttle hardware is proposed for the RCS system and the estimated mass is 1714 kg. A total auxiliary propulsion system mass of 3265 kg includes both the RCS and OMS elements.

Prime Power—The major electrical power sources on the upper stage are both fuel cells and auxiliary power units. The total prime power subsystem mass is estimated to be 1524 kg.

Electric Conversion and Distribution—The stage power conditioning and cabling elements are included in this category. The estimated mass is 907 kg.

Hydraulic Conversion and Distribution—The hydraulic system for the thrust vector control and actuation system is included in this category. The stage hydraulic system also must provide services to the payload access doors in addition to all the stage functions. A mass of 4040 kg is estimated for this category.

Aerosurface Controls—The control system for the aerodynamic surfaces including actuators, fittings, etc. is included in this category. The control system individual element mass was developed using historical relationships as follows:

Element	Proportional Factor	Mass
Wing Surface Controls	Reference area	2608 kg
Vertical Tail Surface Controls	Exposed Area	726 kg
Canard Surface Controls	Exposed Area	372 kg
Body Flap Surface Controls	Total Area	<u>544 kg</u>
	Total =	4250 kg

Avionics—The avionics subsystem includes the guidance and navigation, flight data management, and the communication system elements. The total mass of the avionics subsystem is estimated to be 1814 kg.

Environmental Control—The on-board environmental control system is primarily associated with the thermal conditioning of the avionics equipment and the purge requirements for the main engines after shutdown. The subsystem mass is estimated to be 1134 kg.

5.2.3.2 Upper Stage Mass Characteristics

The upper stage mass characteristics reflect the results of the preliminary structural sizing analysis and incorporation of historical weight estimating relationships. Element masses have been identified and described in Section 5.2.3.1, System Description. The summarized upper stage mass statement is shown in Table 5.2.3-1. A 10% mass growth allowance has been included on all dry mass elements. The total stage dry mass is estimated to be 360880 kg. The major portions of the dry mass are the structural (55%), ascent propulsion (14%), and thermal protection (14%) subsystem.

The fluids inventory is noted in Table 5.2.3-1. Residual and unusable fluids and gases are the major inert item in the fluid inventory. The residual mass estimate reflects a closed loop propellant utilization system.

5.2.3.3 Upper Stage Cost Estimate

The DDT&E and initial production unit cost for the upper stage of the two stage winged vehicle are shown in Table 5.2.3-2. A DDT&E cost of \$3.9B includes the basic stage design and development (\$0.79B), system test (\$2.03B), and tooling, etc. The equivalent of 2.5 vehicles for ground test and 2 for flight test are included in system test category.

The theoretical first unit (TFU) production cost of \$520.9M is proportioned as follows:

Structure	21%
Ascent Propulsion	29%
TPS	12%
Avionics	9%
GSE	9%
Program Management	7%
Other	13%

Approximately 70% of the initial production cost is attributable to the structures, propulsion, thermal protection and avionics subsystems.

An estimated \$50M has been included in DDT&E cost for the upper stage portion of flight test operations.

0-2

Table 5.2.3-1 Winged Upper Stage Mass Statement

SPS-056

93

DRY MASS		
STAGE ELEMENT		10 ³ kg
STRUCTURE:		199.47
BODY	(140.93)	
AEROSURFACES	(58.54)	
THERMAL PROTECTION SYSTEM		48.78
LANDING GEAR		13.85
ASCENT PROPULSION		52.23
AUXILIARY PROPULSION		3.27
PRIME POWER		1.52
ELECTRIC CONVERSION AND DISTRIBUTION		0.91
HYDRAULIC CONVERSION AND DISTRIBUTION		4.84
AEROSURFACE CONTROLS		4.25
AVIONICS		1.81
ECS		1.13
GROWTH		<u>28.12</u>
	DRY MASS	360.88

SECOND STAGE SEQUENCE	
EVENT	MASS AFTER EVENT 10 ³ kg
STAGE @ MECO	813.67
ΔV RESERVE	799.66
APOGEE CIRCULARIZATION (OMS BURN)	780.64
RCS TRIM BURN	775.92
OMS TRIM BURN	774.06
DEPLOY PAYLOAD (MASS=381 120 kg)	392.93
DEORBIT ΔV	<u>382.60</u>
MASS AT LANDING	382.60
RESIDUALS AND UNUSABLES	11.49
RESERVES	<u>10.23</u>
	DRY MASS
	360.88

D180-20689-5

Table 5.2.3-2 Winged Upper Stage DDT&E and 1st Unit Production Costs

NO	NAME	SUB TD	ELEMENT	METHOD	SOUR- CES	BLEND FACTORS	SUPT FROM	DTG %	MUD %	MDD CMLX	NUMBER	LRN %	COST (000)
1	TOTAL PROGRAM	0	DDT&E	SUBS	0	0.00	0	0	0	0.0			3,901,029
			UNIT	SUBS	0	0.00	0				0	0	520,851
2	PRG INTER C MANAG	1	DDT&E	FACTOR	3	0.10	0	0	0	0.0			171,729
			UNIT	FACTOR	3	0.10	0				0	0	36,822
3	WING/WING 2ND	2 (1)	DDT&E	SUBS	0	0.00	0	0	0	0.0			3,679,300
			UNIT	SUBS	0	0.00	0				0	0	484,028
4	FLT VEH 2ND STAGE	3	DDT&E	SUBS	0	0.00	0	0	0	0.0			3,679,300
			UNIT	SUBS	0	0.00	0				0	0	484,028
5	FLT VEH DCD	4	DDT&E	SUBS	0	0.00	0	0	0	0.0			790,170
			UNIT	SUBS	0	0.00	0				0	0	417,267
6	STRUCTURE	5	DDT&E	SUBS	0	0.00	0	0	0	0.0			303,476
			UNIT	SUBS	0	0.00	0				0	0	108,961
7	BODY GROUP	6	DDT&E	SUBS	0	0.00	0	0	0	0.0			199,144
			UNIT	SUBS	0	0.00	0				0	0	69,848
8	LO2 TANK	7	DDT&E	CER	62	1.00	28	0	0	0.0			34,895
	67295 LBS		UNIT	CER	63	1.00	54				1	85	11,124

94

D180-20689-5

ORIGINAL PAGE IS
OF POOR QUALITY

ORIGINAL PAGE IS
OF POOR QUALITY

95

Table 5.2.3-2 (Continued)

9	LM2 TANK 103396	LBS	7	DDT&E CER	62	1.00	28	0	0	0.0		51,152
				UNIT CER	63	1.00	54				1	85
10	AFT SKIRT 78097	LBS	7	DDT&E CER	3	1.00	28	0	0	0.0		55,327
				UNIT CER	37	1.00	54				1	85
11	THRUST STRUCTURE 12942	LBS	7	DDT&E CER	3	1.00	28	0	0	0.0		11,257
				UNIT CER	37	1.00	54				1	85
12	BASE STRUCTURE 11388	LBS	7	DDT&E CER	3	1.00	28	0	0	0.0		10,063
				UNIT CER	37	1.00	54				1	85
13	FWD SKIRT 18411	LBS	7	DDT&E CER	3	1.00	28	0	0	0.0		15,347
				UNIT CER	37	1.00	54				1	85
14	NOSE 26405	LBS	7	DDT&E CER	3	1.00	28	0	0	0.0		21,100
				UNIT CER	37	1.00	54				1	85
15	WING GROUP 105050	LBS	6	DDT&E CER	3	1.00	28	0	0	0.0		72,118
				UNIT CER	37	1.00	54				1	85
16	BODY FLAP 9625	LBS	6	DDT&E CER	3	1.00	28	0	0	0.0		8,686
				UNIT CER	37	1.00	54				1	85

D180-20689-5

Table S.2.3-2 (Continued)

17	TAIL GROUP		6	DDTEE SUBS	0	0.00	0	0	0	0.0		29,527
				UNIT SUBS	0	0.00	0				0 0	8,949
18	CANARD 10780	LBS	17	DDTLE CER	3	1.00	28	0	0	0.0		9,591
				UNIT CER	37	1.00	54				1 85	3,649
19	VERTICAL 16500	LBS	17	DDTLE CER	3	1.00	28	0	0	0.0		13,935
				UNIT CER	37	1.00	54				1 85	5,300
20	TPS		5	DDTEE SUBS	0	0.00	0	0	0	0.0		128,120
				UNIT SUBS	0	0.00	0				0 0	61,006
21	BODY ENTRY 34523	TPS SQF	20	DDTLE CER	64	2.00	28	0	0	0.0		58,531
				UNIT CER	65	2.00	54				1 85	26,546
22	FLAME SHIELD 1964	SQF	20	DDTLE CER	64	2.00	28	0	0	0.0		5,913
				UNIT CER	65	2.00	54				1 85	3,056
23	LO2 INSU 1	SQF	0	DDTEE CER	64	2.00	28	0	0	0.0		23
				UNIT CER	65	2.00	54				1 85	10
24	INTER INSU 1	SQF	0	DDTEE CER	64	2.00	28	0	0	0.0		23
				UNIT CER	65	2.00	54				1 85	10

Table 5.2.3-2 (Continued)

25 LM2 TANK INSU 20020 SQF	20 DDTEE CER	64	1.00	28	0	0	0.0		21,581
	UNIT CER	65	1.00	54				1 85	10,436
26 WING TPS 8935 SQF	20 DDTEE CER	64	2.00	28	0	0	0.0		19,703
	UNIT CER	65	2.00	54				1 85	9,579
27 CANARD TPS 2048 SQF	20 DDTEE CER	64	2.00	28	0	0	0.0		6,111
	UNIT CER	65	2.00	54				1 85	3,154
28 VERT TAIL TPS 4868 SQF	20 DDTEE CER	64	2.00	28	0	0	0.0		12,132
	UNIT CER	65	2.00	54				1 85	6,059
29 BODY FLAP TPS 1250 SQF	20 DDTEE CER	64	2.00	28	0	0	0.0		4,147
	UNIT CER	65	2.00	54				1 85	2,173
30 LANDING SYS 32870 LBS	5 DDTEE CER	6	1.00	28	0	0	0.0		82,714
	UNIT CER	37	1.00	54				1 85	9,698
31 PROP ASCENT	5 DDTEE SUBS	0	0.00	0	0	0	0.0		56,959
	UNIT SUBS	0	0.00	0				0 0	152,497
32 SSME MOD	31 DDTEE \$	0	0.00	0	0	0	0.0		30,000
	UNIT \$	0	0.00	0				14 90	146,857

D180-20689-5

ORIGINAL PAGE IS
OF POOR QUALITY

Table 5.2.3-2 (Continued)

33 SSME ACCES 849 LBS	31 DDTCE CER	6	1.00	28	0	0	0.0		4.130
	UNIT CER	40	1.00	54				14 90	2.971
34 PRDP DELIVERY 12125 LBS	31 DDTCE CER	4	1.00	28	0	0	0.0		13.950
	UNIT CER	40	1.00	54				1 85	1.727
35 PRESS SYS 5017 LBS	31 DDTCE CER	4	1.00	28	0	0	0.0		8.872
	UNIT CER	40	1.00	54				1 85	941
36 PRDP RCS	5 DDTCE SUBS	0	0.00	0	0	0	0.0		12.223
	UNIT SUBS	0	0.00	0				0 0	6.187
37 RCS ENG 1530 LBS	36 DDTCE CER	7	1.00	28	50	0	0.0		7.232
	UNIT CER	39	1.00	54				1 85	5.413
38 RCS PRESSLINES 729 LBS	36 DDTCE CER	4	1.00	28	0	0	0.0		3.472
	UNIT CER	40	1.00	54				1 85	263
39 RCS TANKS 1030 LBS	36 DDTCE CER	62	1.00	28	0	0	0.0		1.510
	UNIT CER	63	1.00	54				1 85	509

ORIGINAL PAGE IS
OF POOR QUALITY

Table S.2.3-2 (Continued)

40 P&DP OMS	5 DDTCE SUBS	0	0.00	0	0	0	0.0		14,373
	UNIT SUBS	0	0.00	0				0 0	2,228
41 ENGINES	40 DDTCE \$	0	0.00	0	0	0	0.0		10,000
	UNIT \$	0	0.00	0				2 90	1,331
42 PRESSLINES 282 LBS	40 DDTCE CER	4	1.00	28	0	0	0.0		2,075
	UNIT CER	40	1.00	54				1 85	129
43 FUEL TANK 1852 LBS	40 DDTCE CER	62	1.00	28	0	0	0.0		1,533
	UNIT CER	63	1.00	54				1 85	515
44 L22 TANK 805 LBS	40 DDTCE CER	62	1.00	28	0	0	0.0		763
	UNIT CER	63	1.00	54				1 85	252
45 PRIME POWER	5 DDTCE SUBS	0	0.00	0	0	0	0.0		31,384
	UNIT SUBS	0	0.00	0				0 0	16,366
46 APU 2460 LBS	45 DDTCE CER	7	1.00	28	0	0	0.0		18,798
	UNIT CER	39	1.00	54				1 85	8,251
47 FUEL CELLSETANKS 1236 LBS	45 DDTCE CER	1	1.00	28	0	0	0.0		12,675
	UNIT CER	34	1.00	54				1 85	8,114

Table 5.2.3-2 (Continued)

48 ELEC CONV/DIS		5 DDTCE SUBS	0	0.00	0	0	0	0.0		6,798
		UNIT SUBS	0	0.00	0				0 0	6,318
49 CONV EQU 440 LBS		48 DDTCE CER	18	1.00	28	0	0	0.0		1,581
		UNIT CER	49	1.00	54				1 85	1,614
50 CONTROLS 295 LBS		48 DDTCE CER	18	1.00	28	0	0	0.0		1,138
		UNIT CER	49	1.00	54				1 85	1,131
51 CABLES AND CONTRGLS 1465 LBS		48 DDTCE CER	15	1.00	28	0	0	0.0		4,078
		UNIT CER	47	1.00	54				1 85	3,572
52 AVIONICS		5 DDTCE SUBS	0	0.00	0	0	0	0.0		70,643
		UNIT SUBS	0	0.00	0				0 0	46,475
53 CONTROLS 1964 LBS		52 DDTCE CER	17	1.00	28	0	0	0.0		63,414
		UNIT CER	48	1.00	54				1 85	38,623
54 COMMUNICATIONS 516 LBS		52 DDTCE CER	18	1.00	28	0	0	0.0		1,804
		UNIT CER	49	1.00	54				1 85	1,860
55 DATA HANDLING 1920 LBS		52 DDTCE CER	18	1.00	28	0	0	0.0		5,424
		UNIT CER	49	1.00	54				1 85	5,991

100

D180-20689-5

ORIGINAL PAGE IS
OF POOR QUALITY

ORIGINAL PAGE IS
OF POOR QUALITY

101

Table 5.2.3-2 (Continued)

56 ECS		5	DDTCE SUBS	0	0.00	0	0	0	0.0		9,488
			UNIT SUBS	0	0.00	0				0 0	3,612
57 TANK PURGE 1246	LBS	56	DDTCE CER	4	1.00	28	0	0	0.0		4,371
			UNIT CER	40	1.00	54				1 85	360
58 COMP BAYS 1504	LBS	56	DDTCE CER	23	1.00	28	0	0	0.0		5,117
			UNIT CER	41	1.00	54				1 85	3,251
59 PAYLOAD SYS 1	LBS	0	DDTCE CER	6	1.00	28	0	0	0.0		27
			UNIT CER	37	1.00	54				1 85	1
60 HYDRAULIC CONV/DIST 11737	LBS	5	DDTCE CER	6	1.00	28	0	0	0.0		35,191
			UNIT CER	40	1.00	54				1 84	1,689
61 AERO SURF CONT		5	DDTCE SUBS	0	0.00	0	0	0	0.0		38,809
			UNIT SUBS	0	0.00	0				0 0	2,225
62 WING SURF CONT 6325	LBS	61	DDTCE CER	6	1.00	28	0	0	0.0		21,138
			UNIT CER	40	1.00	54				1 84	1,103
63 CANARD SURF CONT 902	LBS	61	DDTCE CER	6	1.00	28	0	0	0.0		4,336
			UNIT CER	40	1.00	54				1 84	288

D180-20689-5

Table 5.2.3-2 (Continued)

64 VERT TAIL CONT 1760 LBS	61 DDT&E CER	6	1.00	28	0	0	0.0		7,436
	UNIT CER	40	1.00	54				1 84	457
65 BODY FLAP CONT 1720 LBS	61 DDT&E CER	6	1.00	28	0	0	0.0		5,892
	UNIT CER	40	1.00	54				1 84	375
66 ASSY/C/O	4 DDT&E N/A	0	0.00	0	0	0	0.0		0
	UNIT CER*	5	0.00	0				0 0	19,846
		60	0.00						
67 TOOLING	4 DDT&E FACTOR	5	0.50	0	0	0	0.0		686,226
	UNIT N/A	0	0.00	0				0 0	0
68 SYSTEM TEST	4 DDT&E SUBS	0	0.00	0	0	0	0.0		2,030,586
	UNIT N/A	0	0.00	0				0 0	0
69 SYS TEST LABGR	68 DDT&E CER*	5	0.00	0	0	0	0.0		152,883
		30	0.00						
	UNIT N/A	0	0.00	0				0 0	0
70 GR TEST MDWE	68 DDT&E FAC UN	5	2.50	0	0	0	0.0		1,043,168
	UNIT N/A	0	0.00	0				0 0	0
71 FLT TEST MDWE	68 DDT&E FAC UN	5	2.00	0	0	0	0.0		834,534
	UNIT N/A	0	0.00	0				0 0	0

D180-20689-5

ORIGINAL PAGE IS
OF POOR QUALITY

Table 5.2.3-2 (Continued)

72 SELI	4 DDTCE CER*	5	0.00	0	0	0	0.0	61,554
	UNIT N/A	29	0.00	0				
		0	0.00	0				0 0
73 FLT VEH CDLT	0 DDTCE FACTOR	5	1.00	0	0	0	0.0	0
		72	1.00					
	UNIT N/A	69	1.00	0				0 0
		0	0.00	0				0 0
74 SOFTWARE ENGR	4 DDTCE CER*	73	0.00	0	0	0	0.0	77,997
		39	0.00					
	UNIT N/A	0	0.00	0				0 0
75 CSE	4 DDTCE CER*	5	0.00	0	0	0	0.0	32,764
		56	0.00					
	UNIT CER*	5	0.00	0				0 0
		57	0.00					46,914
76 FLT TEST OPS	1 DDTCE \$	0	0.00	0	0	0	0.0	50,000
	UNIT N/A	0	0.00	0				0 0
77	0 DDTCE SUBS	0	0.00	0	0	0	0.0	0
	UNIT SUBS	0	0.00	0				0 0
78	0 DDTCE SUBS	0	0.00	0	0	0	0.0	0
	UNIT SUBS	0	0.00	0				0 0
79	0 DDTCE SUBS	0	0.00	0	0	0	0.0	0
	UNIT SUBS	0	0.00	0				0 0

103

ORIGINAL PAGE IS
OF POOR QUALITY

D180-20689-5

5.2.4 Vehicle Performance

The vehicle performance for the SPS mission was calculated based on the following ground rules:

- Launch latitude = 28.5°
- ΔV Reserves = .85% ΔV_j
- Delivery orbit
 - Altitude = 477 km circular
 - Inclination = 31°
- Upper stage circularizes and transfers the payload to a staging depot or LEO construction base.

This particular delivery orbit allows for two launch opportunities to each orbit 3 1/3 hours apart. The upper stage, since it delivers the payload to a LEO base, deorbits approximately 24 hours later to return to a landing near the launch site.

The ascent trajectory characteristics for the vehicle are shown in Figure 5.2.4-1. The major characteristics are summarized as follows:

First Stage

TW @ Ignition = 1.30
Maximum dynamic Pressure = 34.446 kpa
Maximum Acceleration = 3.49 g's
Stage Burn Time = 147.96 sec.
Dynamic Pressure at Staging = 1819 pa

Second Stage

TW @ Ignition = 0.95
Maximum Acceleration = 3.67 g's
Stage Burn Time = 351.78 sec.

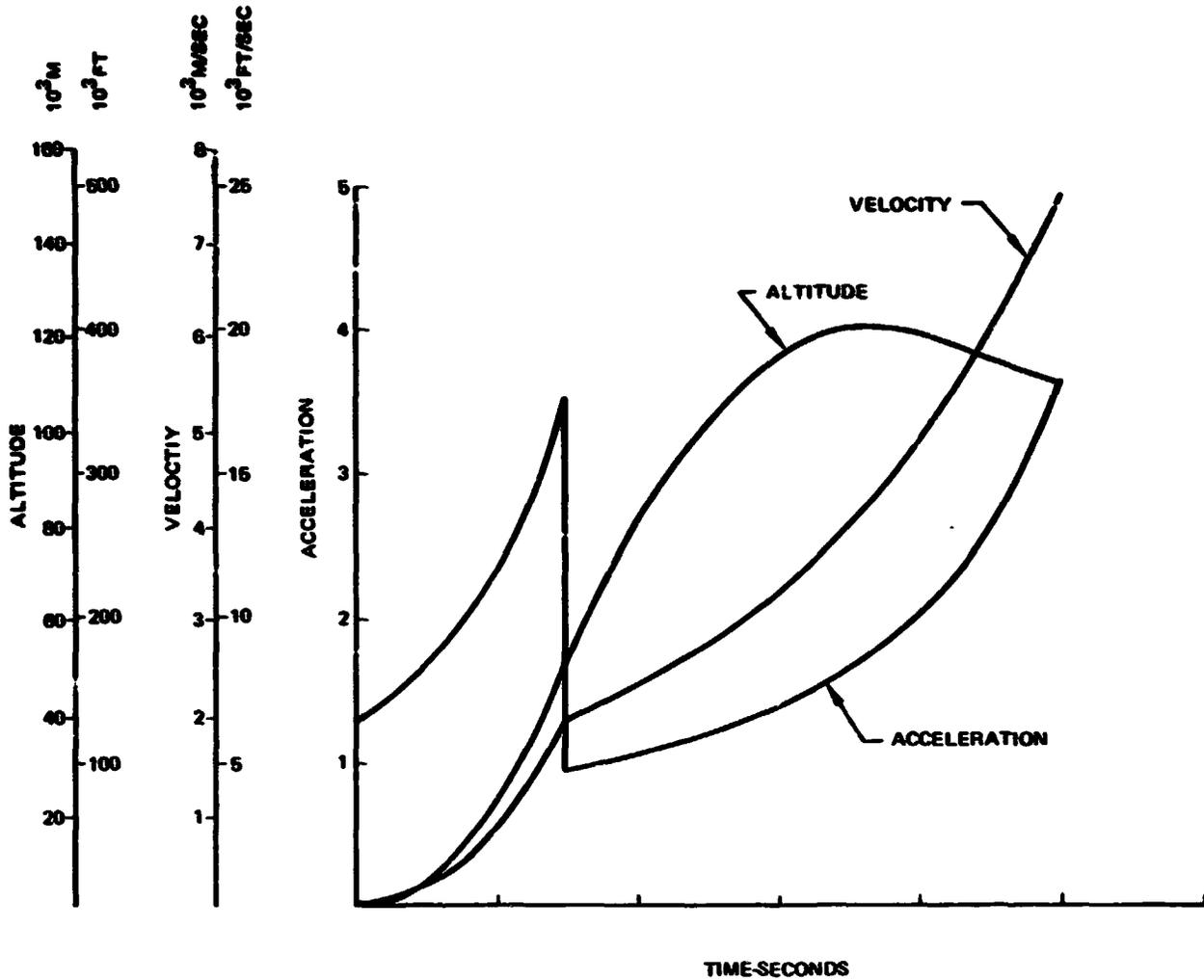

Figure 5.2.4-1 2-Stage Winged Vehicle Ascent Performance Characteristics

At main engine cutoff (MECO) the trajectory characteristics are as follows:

- Altitude = 110852 m
- Relative Velocity = 7539 m/sec
- Burnout Mass = 813667 kg

The circularization burn of 105.6 m/sec and a trim burn of 10.56 m/sec (10% of circularization burn) are performed by the orbit maneuvering system (OMS). In addition, an RCS burn of 17 m/sec is performed. The net payload deployed is 381120 kg and the upper stage landed mass is 382600 kg.

5.2.5 Vehicle Operations

The two stage winged SPS freighter operations are driven by consideration of downrange landing areas for the booster. Two of the options are to, (1) launch from an inland site or (2) an offshore launch to a land recovery area. A NASA/JSC internal study investigating potential western U.S. launch sites for the Heavy Lift Launch Vehicle, dated May 1977, provided data on potential inland launch sites. The basic land use assumptions used in the reference study are shown in Figure 5.2.5-1. Both the launch and landing buffer zones are noted on the figure, in addition to the over flight ground path corridor. Seven potential inland U.S. launch sites, shown in Figure 5.2.5-2, were identified. The land acquisition cost differentials between the candidate sites varied in a range between \$65M and \$1490M dependent on the amount of government vs. private land to be used.

The off-shore launch site operation plan was assumed to have the following features:

- Transporter/Launcher consisting of two large ships with a platform between the hulls.
- Coastal on-shore vertical stacking in a VAB type of facility in an area adjacent to landing area, and vehicle processing facilities.
- Propellants, other launch consumables and launch services are on-board the Transporter/Launcher ships.
- Erected vehicle is transported unfueled from the VAB to the off-shore launch position.

A preliminary facilities and equipment "ROM" cost for the two operational options are shown in Tables 5.2.5-1 and 5.2.5-2. As noted by comparing these preliminary facilities costs, the inland launch site could offer a potential \$1414M advantage. However, if the land acquisition costs were at the extreme of those investigated in the NASA/JSC study of inland launch sites this advantage would be negated. As a result, the selection of an operational mode between inland and off-shore sites is not possible at this time.

The ground operations manpower required to support the 12 launches/day for the GEO satellite assembly is shown in Table 5.2.5-3. The task breakdowns comprise the major activities necessary to recycle the vehicle. Both operations manpower and the associated maintenance personnel are identified. Approximately 660 personnel are involved in processing each vehicle in the turnaround and the resulting average cost per flight is \$355,000.

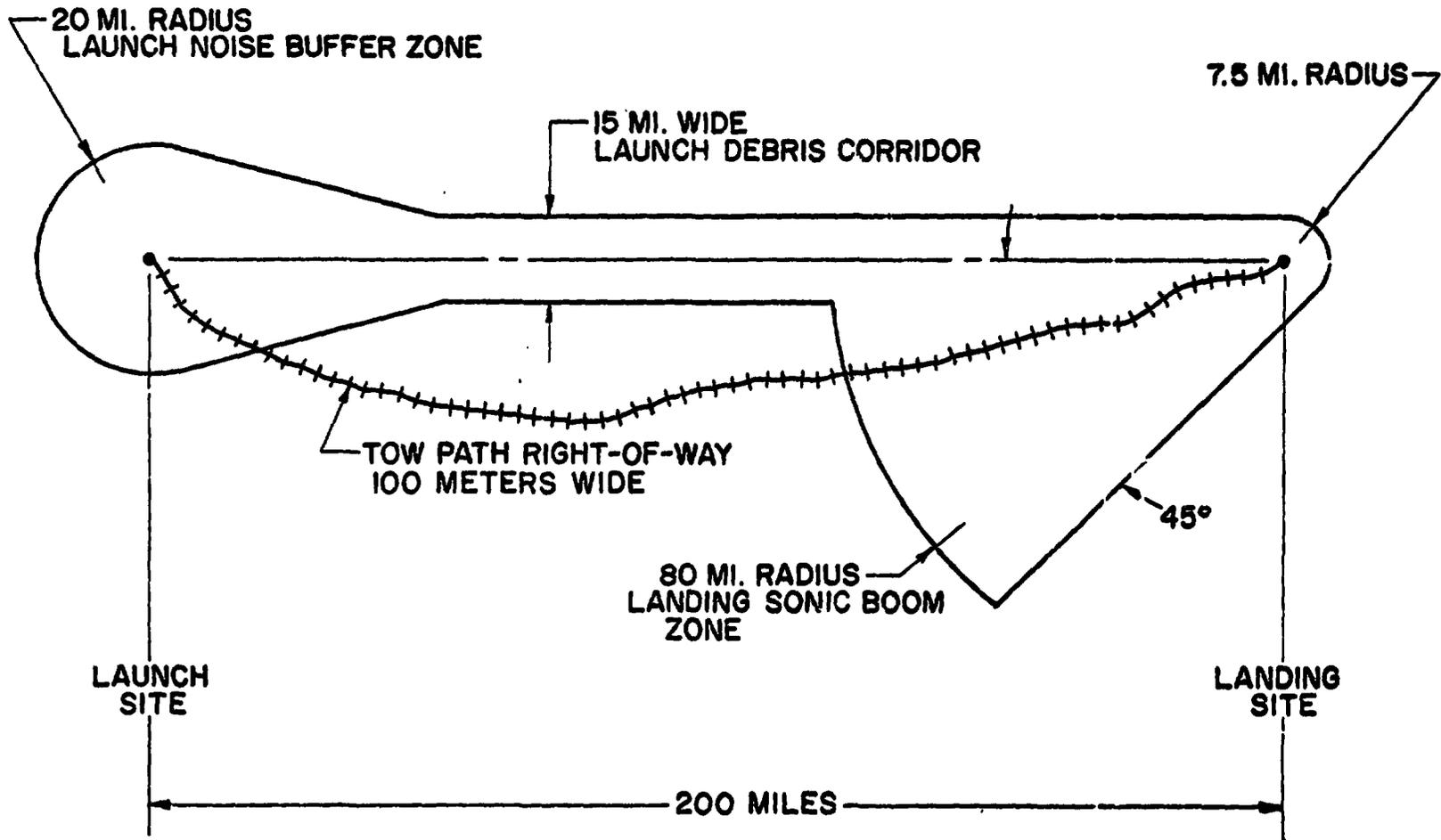
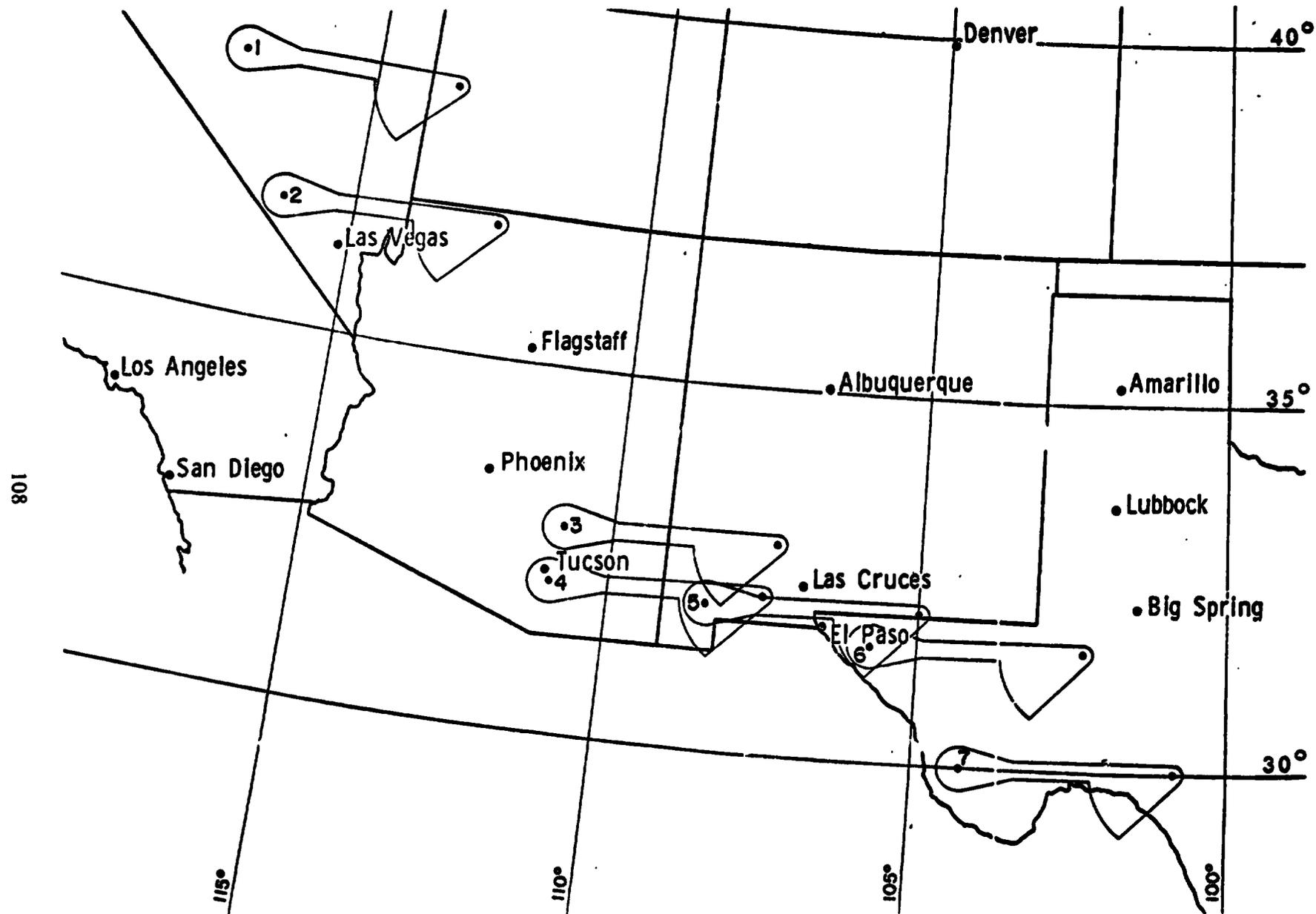

Figure 5.2.5-1 HLLV Land Use Assumptions



108

D180-20689-5

Figure 5.2.5-2 Potential Inland U. S. Launch Sites

Table 5.2.5-1 Estimated Facility Costs Winged/Winged Launch Vehicle Railroad Return

	UNIT COST	NUMBER	COST
VAB POSITIONS	\$878 M	18	\$15,804 M
LAUNCH POSITIONS	116 M	12	1,392 M
MOBILE LAUNCH PLATFORM	100 M	30	3,000 M
RAIL ROAD	500 M	1	500 M
LCC FIRING ROOMS	26 M	12	312 M
PAYLOAD PROCESSING POSITIONS	76 M	4	304 M
LANDING FACILITIES	150 M	1	150 M
TRANSPORTER	50 M	12	600 M
			<u>600 M</u>
			\$22,062 M

D180-20689-5

Table 5.2.5-2 Estimated Facility Costs Winged/Winged Launch Vehicle Ship Launched

	UNIT COST	NUMBER	
VAB POSITIONS	\$743 M	18	\$13,374 M
LAUNCH POSITIONS	—		—
MOBILE LAUNCH PLATFORMS	—		—
LAUNCH SHIPS	402 M	24	9,648 M
LCC FIRING ROOM	—		—
PAYLOAD PROCESSING POSITIONS	76 M	4	304 M
LANDING FACILITIES	150 M	1	150 M
			<u><u>\$23,476 M</u></u>

110

D180-20689-5

Table 5.2.5-3 Ground Operations Manpower Requirements—GEO Assembly

SPS 601

	ANNUAL OPERATIONS HEADCOUNT	
	OPERATIONS	MAINTENANCE
FIRST STAGE PROCESSING	978 -VEHICLE INSPECTIONS	1886 INSPECTION PICKUP & MAINT
SECOND STAGE PROCESSING	1442 -VEHICLE INSPECTIONS	2710 INSPECTION PICKUP & MAINT
MOBILE LAUNCHER ACTIVITIES	1075	4865 EQUIPMENT MAINTENANCE
FIRST & SECOND STAGE INSTALLATION ON MOBILE LAUNCHER	403	
VEHICLE INTEGRATION TESTING	161	
PAYLOAD INSTALLATION & CHECKOUT	161	
SUPPORT FOR MOVE TO LAUNCH SITE	242	
FIRST STAGE RECOVERY OPERATIONS	1913	344 EQUIPMENT MAINTENANCE
VAB TEST STATION	1566	576 EQUIPMENT MAINTENANCE
SECOND STAGE RECOVERY OPERATIONS	604	96 EQUIPMENT MAINTENANCE
LAUNCH CONTROL CENTER	1206	144 EQUIPMENT MAINTENANCE
LAUNCH SITE INSTALLATION & CHECKOUT	645	336 EQUIPMENT MAINTENANCE
PROPELLANT SYSTEM	1276	706 EQUIPMENT MAINTENANCE
GAS STORAGE & DISTRIBUTION	288	144 EQUIPMENT
Σ	= 11960	= 11807

111

D180-20689-5

● 36 VEHICLES IN THE TURNAROUND AT ANYTIME

PERSONNEL/VEHICLE = 600

TOTAL COST = \$1108M
COST/FLT = \$0.355M

5.2.6 2-Stage Winged Vehicle Cost per Flight

The cost per flight of the 2-stage winged SPS Freighter was developed to the operations cost work breakdown structure (WBS) shown in Table 5.2.6-1. The operations cost WBS is modeled after the Shuttle User Charge WBS with the following additions:

- Production costs for reusable hardware is included.
- Tooling costs associated with the tooling shipsets required for rate production is included.

The average cost per flight data developed in this section is based on the GEO assembly option which results in 3125 launches per year for a 14 year period. The following paragraphs will discuss the methodology in developing the cost per flight data.

Flight Hardware Elements—The flight hardware cost per flight element summary is shown in Table 5.2.6-2. The production quantity of equivalent units for 14 years of operations include:

1. The initial buy required to satisfy turnaround.
2. The additional vehicles required for life (using a 300 flight limit on service time)
3. Refurbishment units resulting from a 30% replacement each 100 flights for the airframe and every 50 flights for the engines.
4. Replenishment spares purchased and installed at a rate of 0.18% and 0.50% per flight respectively for the airframe and engines.

The initial unit costs are noted and improvement curves of 85% and 90% on airframe and engines respectively, were used to develop the total program cost. The cost per flight of these hardware elements was developed by averaging the total program cost over the 43750 flights which occur in the 14 years of operations.

Tooling Cost/Flight Elements—The portion of cost per flight associated with rate tooling is shown in Table 5.2.6-3. The required number of shipsets and the respective first unit cost are shown in the two columns on the left of the table. The tool production cost results from using an 85% improvement curve for the required number of units. Tool sustaining was estimated at 10% per year of the tool fabrication costs for the 14 years of operations.

Table 5.2.6-1 Cost/Flight WBS

SPS-590

WBS ELEMENT
OPERATIONS COST
PROGRAM DIRECT PROGRAM SUPPORT PRODUCTION AND SPARES STAGE 1 AIRFRAME ENGINES STAGE 2 AIRFRAME ENGINES TOOLING STAGE 1 STAGE 2 GROUND OPS/SYS GROUND OPS GROUND SYS GSE SUSTAINING ENGR GSE SPARES PROPELLANT OTHER
DIRECT MANPOWER CIVIL SERVICE SUPPORT CONTRACTOR
INDIRECT MANPOWER CIVIL SERVICE SUPPORT CONTRACTOR

Table 5.2.6-2 Flight Hardware Cost/Flight Elements

SPS 603

PRODUCTION AND SPARES	INITIAL BUY TO SATISFY TURNAROUND	UNIT QUANTITIES			EQUIVALENT VEHICLE UNITS	THEORETICAL FIRST UNIT COST \$M	LEARNING CURVE λ(%)	TOTAL PROGRAM COST - \$M	COST/FLIGHT = TOTAL PROGRAM COST/ 43750 FLTS - \$M
		Δ BUY FOR LIFE	REFURBISH-MENT	REPLENISH-MENT SPARES					
STAGE 1									
AIRFRAME	41	105 (300 FLT LIFE)	88 (30% EACH 100 FLTS)	79 (.18% EACH FLT)	(313)	\$413.7	85	43700	0.999
ENGINES	656	N/A (INDE-FINITE LIFE)	4004 (30% EACH 50 FLTS)	3500 (.50% EACH FLT)	(8160)	\$10.3	90	25193	0.578
STAGE 2									
AIRFRAME	51	95	88 (30% EACH 100 FLTS)	79 (.18% EACH FLT)	(313)	\$374.0	85	39503	0.903
ENGINES	714	N/A (INDE-FINITE LIFE)	3461 (30% EACH 50 FLTS)	3063 (.50% EACH FLT)	(7238)	\$15.07	90	33304	0.761

114

D180-20689-5

- 1977 DOLLARS
- 14 YEAR PROGRAM

Table 5.2.6-3 Tooling Cost/Flight Elements

SPS-604

	NUMBER OF SHIPSETS FOR RATE	TOOL FIRST UNIT COST \$M	LEARNING %	TOOL PRODUCTION COST \$M	TOOL SUSTAINING COST \$M ¹	COST/FLT \$M
STAGE 1 AIRFRAME	10	\$408.9	85	\$2874	\$4024	\$.158
STAGE 1 ENGINES	54	\$67.9	85	\$1839	\$2575	\$.101
STAGE 2 AIRFRAME	10	\$301.8	85	\$2149	\$3008	\$.118
STAGE 2 ENGINES	47	\$33	85	\$802	\$1123	\$.044

\$.259M

\$.162

D180-20689-5

115

¹ 10% PER YEAR FOR 14 YEARS

- 1977 DOLLARS
- 14 YEAR PROGRAM

Ground Operations Cost/Flight Elements—Fourteen ground operations tasks were identified and manloaded. These tasks are identified in Table 5.2.6-4 and the annual headcount for operations and maintenance noted. The “hands-on” personnel were estimated for each operations task including the additional manpower associated with maintenance and repair. The annual headcount for each task is noted and a total of nearly 24,000 people are involved for the GEO assembly yearly flight rate of 3125 launches. Since 36 vehicles are in the turnaround at any time, this averages 660 men per vehicle and a resulting cost per flight of \$355,000. This cost is in addition to the stage refurbishment and repair activities included in the Production and Spares WBS entry.

Propellant Cost/Flight Element—The propellant cost for the launch vehicle are shown in Table 5.2.6-5. A burden factor is 5% on the cryogenic and 2% on the RP-1 propellants accounts for the wasted or nonreusable propellant on each launch. The majority of the excess cryogenic propellant is assumed to be captured and re-refrigerated since this approach appears to be much more cost effective than allowing boiloff to the atmosphere. The 5% cryogenic factor accounts for the portion that is lost to the atmosphere during vehicle processing. The unit cost of propellants were developed based on a review of potential manufacturing methods and using a cost consistent with the most probable method. For example, the LH₂ cost of \$2.623/kg is based on steam reformation of coal. Electrolysis costs for the production of LH₂ based on “boot-strap” approach of using SPS generated electrical power would be in the neighborhood of \$3.86/kg. Although fluctuations in the price of liquid hydrogen can be expected, there is a fundamental relationship between the cost of liquid hydrogen and the cost of other energy forms. For large quantities of liquid hydrogen (especially if the buy is uniformly spread over a long period) this fundamental relationship will eventually control the price.

Major Manpower Cost/Flight Elements—The major NASA center and their support contractor manpower estimates are shown in Table 5.2.6-6. The average annual salary rates are estimated by extrapolating the Shuttle User Charge Data to 1977 dollars. These data were generated by review and modification of the Shuttle User Charge Data as applicable to the SPS Freighter concept. The resultant headcount per vehicle is 4100 and compared to a commercial airline, such as United, it is between one and two orders of magnitude greater.

Average Operating Cost/Flight Summary (GEO ASSEMBLY)—The total average cost per flight is \$7.934M for the 2-stage winged SPS Freighter when the other minor elements are included as shown in Table 5.2.6-7. The total manpower involved in this activity is in the neighborhood of 435,000 personnel.

**ORIGINAL PAGE IS
OF POOR QUALITY**

Table 5.2.6-4 Ground Operations Cost/Flight Elements

SPS-601

	ANNUAL OPERATIONS HEADCOUNT	
	OPERATIONS	MAINTENANCE
FIRST STAGE PROCESSING	978 -VEHICLE INSPECTIONS	1886 INSPECTION PICKUP & MAINT
SECOND STAGE PROCESSING	1442 -VEHICLE INSPECTIONS	2710 INSPECTION PICKUP & MAINT
MOBILE LAUNCHER ACTIVITIES	1075	4885 EQUIPMENT MAINTENANCE
FIRST & SECOND STAGE INSTALLATION ON MOBILE LAUNCHER	403	
VEHICLE INTEGRATION TESTING	161	
PAYLOAD INSTALLATION & CHECKOUT	161	
SUPPORT FOR MOVE TO LAUNCH SITE	242	
FIRST STAGE RECOVERY OPERATIONS	1913	344 EQUIPMENT MAINTENANCE
VAB TEST STATION	1566	576 EQUIPMENT MAINTENANCE
SECOND STAGE RECOVERY OPERATIONS	604	96 EQUIPMENT MAINTENANCE
LAUNCH CONTROL CENTER	1206	144 EQUIPMENT MAINTENANCE
LAUNCH SITE INSTALLATION & CHECKOUT	645	336 EQUIPMENT MAINTENANCE
PROPELLANT SYSTEM	1276	706 EQUIPMENT MAINTENANCE
GAS STORAGE & DISTRIBUTION	288	144 EQUIPMENT
Σ	= 11960	= 11807

117

D180-20689-5

● 36 VEHICLES IN THE TURNAROUND AT ANYTIME

PERSONNEL/VEHICLE = 660

TOTAL COST = \$1108M
COST/FLT = \$0.355M

Table 5.2.6-5 Propellant Cost/Flight Element

SPS 600

	LOADED MASS (kg)	BURDEN FACTOR	PROPELLANT COST (\$/kg)	COST/FLIGHT
FIRST STAGE				
LO ₂	4 130 720	1.05	.095	417130
RP-1	1 444 560	1.02	.214	315000
LH ₂	60 950	1.05	2.623	167900
SECOND STAGE				
LO ₂	1 969 900	1.05	.095	196080
LH ₂	328 320	1.05	2.623	904400
TOTAL PROPELLANT COST/FLIGHT				\$ 2,000,600

1.8

D180-20689-5

Table 5.2.6-6 Major Manpower Cost/Flight Elements

SPR 803

	ANNUAL HEADCOUNT	AVERAGE YEARLY RATE	ANNUAL COST \$M	COST/FLIGHT
PROGRAM SUPPORT	23100	\$38,000	\$878	\$.281
DIRECT MANPOWER				
CIVIL SERVICE	29400	\$38,000	\$1116	\$.357
SUPPORT CONTRACTOR	30800	\$33,000	\$1016	\$.325
INDIRECT MANPOWER				
CIVIL SERVICE	32900	\$38,000	\$1250	\$.400
SUPPORT CONTRACTOR	31700	\$33,000	\$1047	\$.335
Σ	= 147900			

HEADCOUNT/VEHICLE = 147900/36 = 4100

- **UNITED AIRLINES HAS**
- **TOTAL HEADCOUNT/AIRCRAFT = 125**
- **MAINTENANCE HEADCOUNT/AIRCRAFT = 22**

119

D180-20689-5

Table 5.2.6-7 Average Operating Cost/Flight—GEO Assembly

SPS-591

WBS ELEMENT	COST BY WBS LEVEL — \$M				
	①	②	③	④	⑤
OPERATIONS COST					
PROGRAM DIRECT	7.934	6.617			
PROGRAM SUPPORT			0.281		
PRODUCTION AND SPARES			3.239		
STAGE 1				1.575	
AIRFRAME					0.999
ENGINES					0.576
STAGE 2				1.664	
AIRFRAME					0.903
ENGINES					0.761
TOOLING			0.421		
STAGE 1				0.259	
STAGE 2				0.162	
GROUND OPS/SYS			2.576		
GROUND OPS				0.355	
GROUND SYS				0.050	
GSE SUSTAINING ENGR				0.047	
GSE SPARES				0.106	
PROPELLANT				2.001	
OTHER				0.017	
DIRECT MANPOWER		0.682			
CIVIL SERVICE			0.357		
SUPPORT CONTRACTOR			0.325		
INDIRECT MANPOWER		0.735			
CIVIL SERVICE			0.400		
SUPPORT CONTRACTOR			0.335		

126

D180-20689-5

TABLE OF CONTENTS

	Page
5.3.1 Vehicle Geometry	121
5.3.2 Booster Stage	125
5.3.2.1 Booster Stage System Description	125
5.3.2.2 Booster Mass Characteristics	126
5.3.2.3 Booster Cost Estimate	128
5.3.3 External Tank	137
5.3.3.1 System Description	137
5.3.3.2 ET Mass Characteristics	138
5.3.3.3 ET Cost Estimate	139
5.3.4 Vehicle Performance	139
5.3.5 Personnel Module	141
5.3.6 Personnel Vehicle Cost per Flight	143

5.3 PERSONNEL CARRIER VEHICLE

The personnel carrier vehicle provides for the transportation of the crews between earth and low earth orbit. The vehicle is a derivative of the current Space Shuttle system which incorporates a liquid propellant booster in place of the Solid Rocket Boosters (SRB's). A series-burn ascent mode was selected and as a result a reduced External Tank (ET) propellant load is required.

The personnel launch vehicle, shown in Figure 5.3-1, incorporates a propane fueled booster, External Tank and Space Shuttle Orbiter. Overall vehicle geometry and characteristics are shown on the figure. The overall length of 60.92 m is due to the tandem arrangement rather than the sidemounted concept in the current Shuttle system.

5.3.1 Vehicle Geometry

The overall vehicle geometry of the personnel launch vehicle is shown on Figure 5.3.1-1. All major body section locations are noted in the body station numbering system. The booster stage is 22.9 m in length with a 8.407 m diameter at the ET interface and a maximum diameter of 18.796 m. Four (4) booster engines are mounted on a 7.008 m diameter. The booster stage propellant tank volumes are 1035 m³ for LO₂ and 593 m³ for C₃H₈.

The ET overall length of 37.93 m reflects the shorter length as compared to the current Shuttle ET due to the reduction in propellant load from 703 075 kg to 547 038 kg.

SPS-581

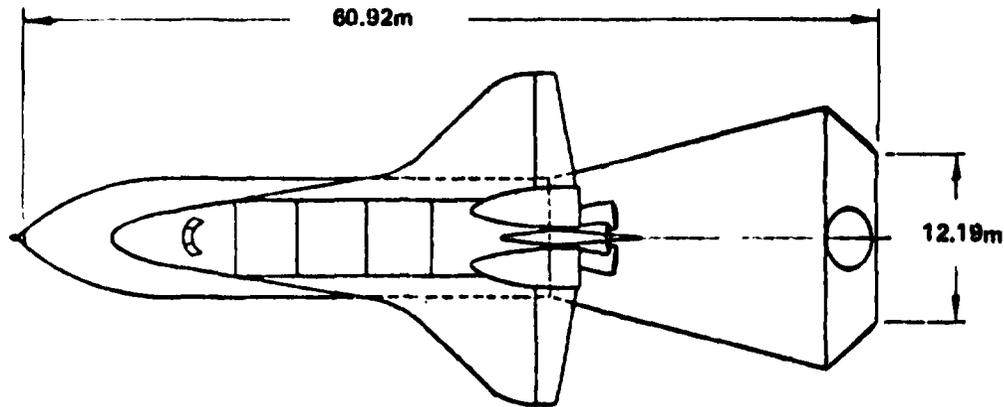

GLOW	2.512X10 ⁶ KG				
BLOW	1.779X10 ⁶ KG				
W _{P1}	1.560X10 ⁶ KG				
ULOW	.659X10 ⁶ KG				
W _{P2}	.547X10 ⁶ KG				
PAYLOAD	.074X10 ⁶ KG				
T/W AT LIFTOFF	1.238				
MAIN PROPULSION					
STAGE	E	NUMBER/TYPE	THRUST/ENGINE (VACUUM)		I _{sp} SEC
			10 ⁶ N	10 ⁵ lbf	
1	40	4-C ₃ H ₈	8.523	1.916	340.0
2	77.5	3 SSME	2.091	.470	455.2

122

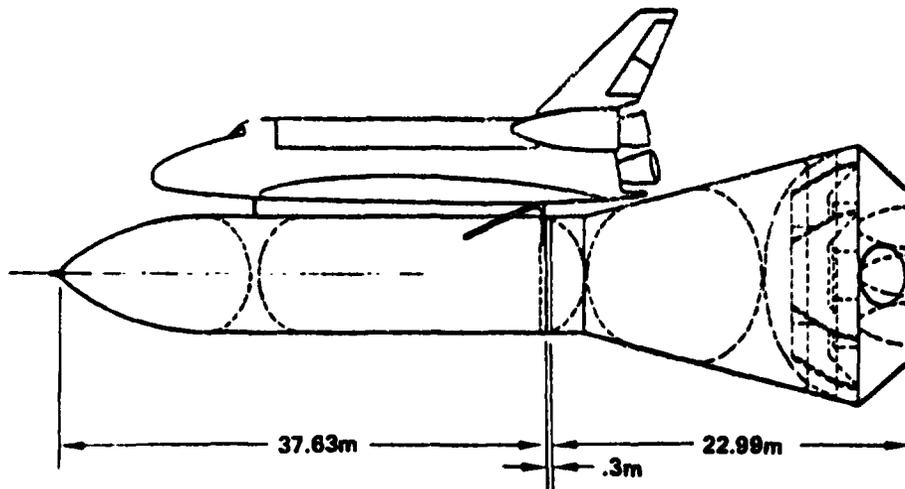

ORIGINAL PAGE IS
OF POOR QUALITY

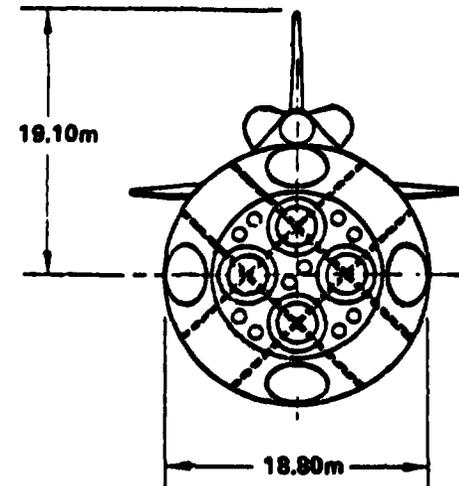

D180-20689-5

Figure 5.3.1-1 Personnel Launch Vehicle

FOLDOUT FRAME 1 .

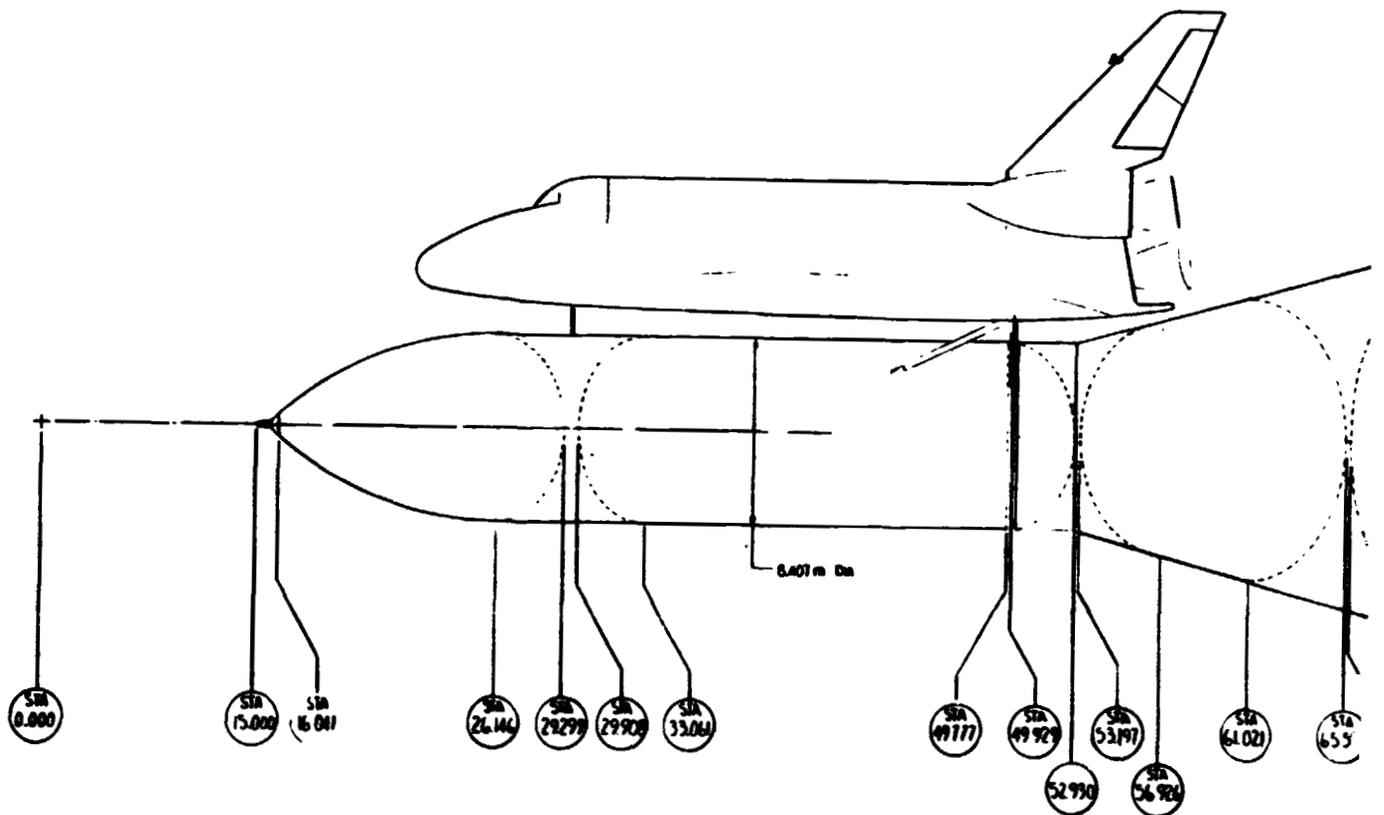
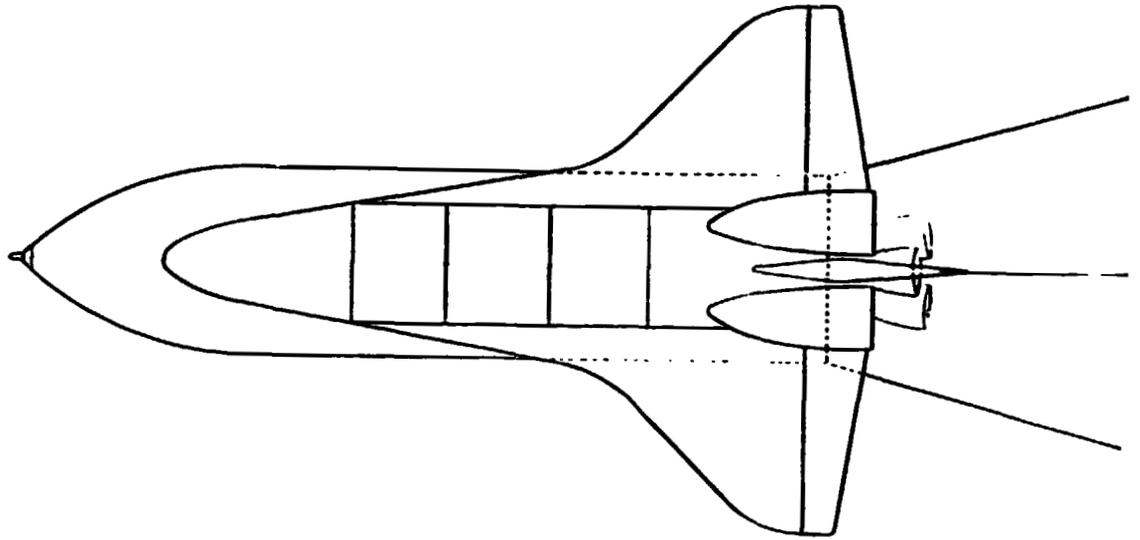

**ORIGINAL PAGE IS
OF POOR QUALITY.**

FOLDOUT FRAME 2.

D180-20689-5

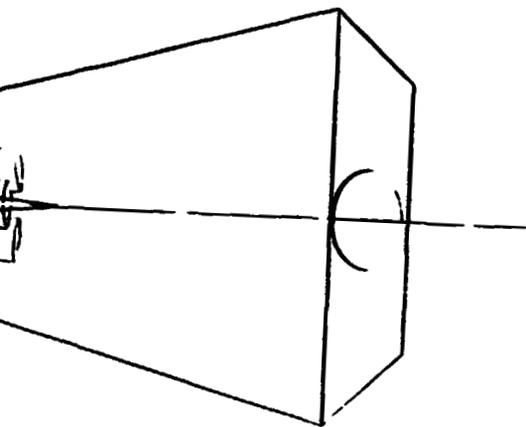

VEHICLE CHARACTERISTICS

- GLOW
- BLOW W_{p1}
- ULOW W_{p2}
- PAYLOAD
- T/W @ LIFT-OFF
- MAIN PROPULSION

STAGE	C	NUMBER / TYPE	THRUST (kg)		BURNOUT WEIGHT (kg)	
			at lift-off	at burnout	at lift-off	at burnout
1	1	15773	15773	15773	15773	15773
2	1	65326	65326	65326	65326	65326
3	1	64021	64021	64021	64021	64021
4	1	64034	64034	64034	64034	64034

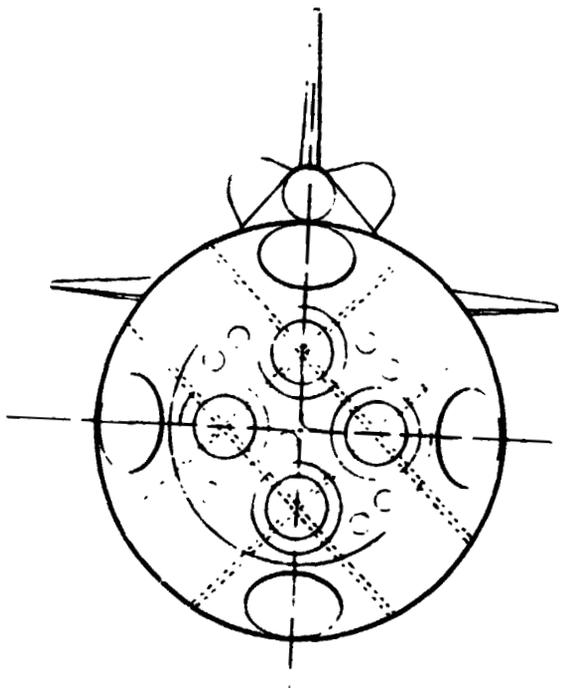
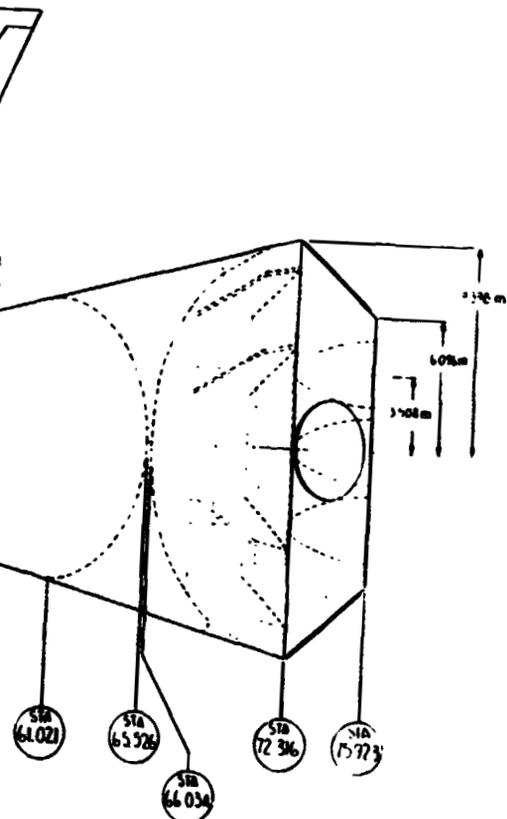

Figure 5.3.1-1 Personnel Launch Vehicle Configuration
123 & 124

ORIGINAL PAGE IS
OF POOR QUALITY

5.3.2 Booster Stage

5.3.2.1 Booster Stage System Description

The booster stage subsystems include the ascent propulsion, structures, auxiliary propulsion system, thermal protection, prime power, power conversion and distribution, avionics and environmental control.

Ascent Propulsion—The booster stage is powered by four C₃H₈/LO₂ engines which provide 8.523 X 10⁶N of vacuum thrust. The following engine characteristics were used in the analysis:

Propellants	C ₃ H ₈ /LO ₂
Thrust - Vacuum	8.523 X 10 ⁶ N
Chamber Pressure	20685 kpa
Mixture Ratio	2.68:1
Specific Impulse - (S.L./Vac.)	304.1/340.0 sec
Total Flow Rate/Engine	2556.5 kg/sec

The pressurization gases are heated GH_e and GO₂ for the main tanks. Individual propellant delivery lines are provided to each engine. The total mass of the ascent propulsion system is 47 138 kg.

Structure—The pressurized structure (C₃H₈ and LO₂ tanks) are 2219-T87 aluminum all-welded components. The unpressurized structure is primarily 6A1-4V titanium with graphite composites incorporated on the internal structural members. The main propellant tank maximum design pressures, peak proof pressures and resultant mass are shown in Table 5.3.2-1.

TABLE 5.3.2-1 C₃H₈ BOOSTER TANK SIZING RESULTS

Structural Element	Maximum Design Pressure - fepa	Maximum Proof Pressure - fepa	Typical Thickness - cm	Mass - kg
LO ₂ Tank	324.5	431.6	0.27 - 0.76	10685
C ₃ H ₈ Tank	226.9	301.3	0.45 - 1.27	28818

D180-20689-5

The unpressurized structure was analyzed for maximum compressive load conditions and the results are shown in Table 5.3.2-2.

TABLE 5.3.2-2 C₃H₈ BOOSTER UNPRESSURIZED STRUCTURE SIZING RESULTS

Structural Element	Maximum Unit Compressive Loading	Typical Thickness - cm	Mass - kg
Forward Skirt	12630 - 15850 N/cm	0.38 - 0.48	3512
Aft Skirt	8966 - 9978 N/cm	0.27 - 0.30	7927
Base Skirt	Pressure = 77.57 kpa	0.88 - 1.00	26034
Thrust Structure	P/Engine = 12.79 X 10 ⁶ N	N/A	18340

Auxiliary Propulsion—The auxiliary propulsion system consists of the landing system and reaction control system. The landing system was sized to provide the terminal deceleration and 10 pressure-fed storeable propellant engines were selected. The baseline landing engine is the Aerojet Engine Model AJ10-51 which uses N₂O₄/UDMH propellants and has a thrust range of between 222400N and 667200N. The landing system dry mass is estimated to be 5192 kg. The reaction control system (RCS) provides for stage orientation prior to entry and control during the reentry. Four (4) sets of thrusters (4 thrusters/set) are installed on the vehicle. The estimated mass of the RCS system is 324 kg.

Other Subsystems—The remaining subsystem masses have been estimated using historical relationships or Shuttle predicted masses. These subsystems include thermal protection, prime power, power, power conversion and distribution, avionics and environmental control.

5.3.2.2 Booster Mass Characteristics

The mass characteristics of the C₃H₈ booster reflect the results of a preliminary structural sizing and the incorporation of historical weight estimating relationships. A mass summary for the C₃H₈ booster is shown in Table 5.3.2-3. A 10% mass growth allowance has been included.

TABLE 5.3.2-3 C₃H₈ BOOSTER MASS STATEMENT

<u>Vehicle Element</u>	<u>Mass - kg</u>
Structure	(90985)
Forward Skirt	3512
LO ₂ Tank	10685
C ₃ H ₈ Tank	28818
Thrust Structure	18340
Aft Skirt	3596
Base Skirt (Including TPS = 10410 kg)	26034
Main Propulsion	(47138)
Engines and Accessories	33669
Gimbal Control System	3148
Fuel System	4508
LO ₂ System	5813
Auxiliary Propulsion	(5486)
Landing System	5162
RCS	324
Prime Power	(815)
Power Conversion and Distribution	(1733)
Avionics	(2744)
ECS	(857)
Growth (10%)	(14976)
	<u>164734</u>
Dry Mass	=
	164734
Residuals and unusables	28460
Landing Propellant and Reserves	25515
	<u>218709</u>
Inert Mass	=
	218709

D180-20689-5

5.3.2.3 Booster Cost Estimate

The C₃H₈ booster DDT&E and 1st Unit cost estimates have been developed in a manner similar to that described in Section 5.1.2.3. The DDT&E and initial production cost for the booster are shown in Table 5.3.2-4. A DDT&E cost of \$2.49B includes the basic stage design and development (\$1.07B), and tooling, etc. The equivalent of 2.5 vehicles for ground test and 2 vehicles for flight test are included in the system test category.

The theoretical first unit (TFU) production cost of \$221M is proportioned as follows:

Structure	24%
Ascent Propulsion	19%
Avionics	26%
GSE	10%
Program Management	8%
Other	13%

Structure, ascent propulsion and avionics account for 69% of the initial production unit cost. An estimated \$100M has been included in the DDT&E cost for flight test operations.

Table 5.3.2-4 ³Hg Booster DDT&E and 1st Unit Production Costs

NO	NAME	SUB TO	ELEMENT METHOD	SOJR- CES	BLEND FACTORS	SUPT FRAC	DYS %	HDD %	HDD CMPLX	NUMBER	LRN %	COST (000)
1	TOTAL PROGRAM	0	DDT&E SUBS	0	0.00	0	0	0	0.0			2,496,294
			UNIT SUBS	0	0.00	0				0	0	220,955
2	PRCG INTER & MANAG	1	DDT&E FACTOR	3	0.10	0	0	0	0.0			76,807
			UNIT FACTOR	3	0.10	0				0	0	17,779
3	FLT VEH ALL STAG	1	DDT&E SUBS	0	0.00	0	0	0	0.0			2,317,486
			UNIT SUBS	0	0.00	0				0	0	203,175
4	FLT VEH 1ST STAG	3	DDT&E SUBS	0	0.00	0	0	0	0.0			2,317,486
			UNIT SUBS	0	0.00	0				0	0	203,175
5	FLT VEH DED	4	DDT&E SUBS	0	0.00	0	0	0	0.0			1,066,872
			UNIT SUBS	0	0.00	0				0	0	176,227
6	STRUCTURE	5	DDT&E SUBS	0	0.00	0	0	0	0.0			166,127
			UNIT SUBS	0	0.00	0				0	0	52,237
7	LD2 TANK 25911 LBS	6	DDT&E CER	62	1.00	28	0	0	0.0			14,996
			UNIT CER	63	1.00	54				1	25	4,918
8	FUEL TANK 69886 LBS	6	DDT&E CER	62	1.00	28	0	0	0.0			36,087
			UNIT CER	63	1.00	54				1	25	11,499

129

ORIGINAL PAGE IS
OF POOR QUALITY

D180-20689-5

Table S.3.2-4 (Continued)

9 AFT SKIRT 5720 LBS	6 DDTCE CER	3	1.00	28	0	0	0.0		7,968
	UNIT CER	37	1.00	54				1 85	3,030
10 THRUST STRUCTURE 44475 LBS	6 DDTCE CER	3	1.00	28	0	0	0.0		33,502
	UNIT CER	37	1.00	54				1 85	12,642
11 FWD SKIRT 6517 LBS	6 DDTCE CER	3	1.00	28	0	0	0.0		7,806
	UNIT CER	37	1.00	54				1 85	2,968
12 BASE SKIRT 63135 LBS	6 DDTCE CER	3	1.00	28	0	0	0.0		65,764
	UNIT CER	37	1.00	54				0 0	17,188
13 MAIN PROPULSION	5 DDTCE SUBS	0	0.00	0	0	0	0.0		681,760
	UNIT SUBS	0	0.00	0				0 0	42,517
14 MAIN ENGINES 1.916E6 THRUST	13 DDTCE CER	26	1.00	28	0	0	0.0		630,153
	UNIT CER	53	1.00	54				4 90	34,666
15 ENGINE ACCES 7635 LBS	13 DDTCE CER	6	1.00	28	0	0	0.0		24,679
	UNIT CER	40	1.00	54				4 90	4,472
16 PROP DELIVERY 20022 LBS	13 DDTCE CER	4	1.00	28	0	0	0.0		18,063
	UNIT CER	40	1.00	54				1 85	2,439

130

ORIGINAL PAGE IS
OF POOR QUALITY

D180-20689-5

Table 5.3.2-4 (Continued)

17 PRESS SYS 5006	LBS	13 DDTCE CER	4	1.00	28	0	0	0.0		8,862
		UNIT CER	40	1.00	54				1 85	939
18 AUX PROP SYS		5 DDTCE SUBS	0	0.00	0	0	0	0.0		114,622
		UNIT SUBS	0	0.00	0				0 0	6,004
19 LANDING SYS		18 DDTCE SUBS	0	0.00	0	0	0	0.0		111,502
		UNIT SUBS	0	0.00	0				0 0	4,519
20 ENGINES 150E+03	THRUST	19 DDTCE CER	26	1.00	28	0	0	0.0		106,209
		UNIT CER	59	1.00	54				10 90	3,373
21 FUEL TANK 1113	LBS	19 DDTCE CER	62	1.00	28	0	0	0.0		1,000
		UNIT CER	63	1.00	54				1 85	333
22 LOZ TANK 2461	LBS	19 DDTCE CER	62	1.00	28	0	0	0.0		1,965
		UNIT CER	63	1.00	54				1 85	661
23 PRESSCLINES 355	LBS	19 DDTCE CER	4	1.00	28	0	0	0.0		2,327
		UNIT CER	40	1.00	54				1 85	151
24 PROP RCS		18 DDTCE SUBS	0	0.00	0	0	0	0.0		3,119
		UNIT SUBS	0	0.00	0				0 0	1,485

D180-20689-5

131
ORIGINAL PAGE IS
OF POOR QUALITY

Table 5.3.2-4 (Continued)

25 RCS ENG 290	LBS	24 DDTCE CER	7	1.00	28	100	0	0.0		412
		UNIT CER	39	1.00	54				1 85	1,211
26 RCS PRESLLINES 155	LBS	24 DDTCE CER	4	1.00	28	0	0	0.0		2,327
		UNIT CER	40	1.00	54				1 85	151
27 RCS TANKS 343	LBS	24 DDTCE CER	62	1.00	28	0	0	0.0		379
		UNIT CER	63	1.00	54				1 85	121
28 PRIME POWER		5 DDTCE SUBS	0	0.00	0	0	0	0.0		18,591
		UNIT SUBS	0	0.00	0				0 0	9,228
29 APU 1316	LBS	28 DDTCE CER	7	1.00	28	0	0	0.0		17,298
		UNIT CER	39	1.00	54				1 85	4,707
30 FUEL CELLS/TANKS 661	LBS	28 DDTCE CER	1	1.00	28	0	0	0.0		7,293
		UNIT CER	35	1.00	54				1 85	4,521
31 ELEC CONV/DIS		5 DDTCE SUBS	0	0.00	0	0	0	0.0		6,594
		UNIT SUBS	0	0.00	0				0 0	6,085
32 CONV EQU 422	LBS	31 DDTCE CER	18	1.00	28	0	0	0.0		1,528
		UNIT CER	49	1.00	54				1 85	1,556

132

D180-20689-5

ORIGINAL PAGE IS
OF POOR QUALITY

Table 5.3.2-4 (Continued)

33 CONTROLS 293	LBS	31 DDTCE CER	18	1.00	28	0	0	0.0	7,100
		UNIT CER	49	1.00	54				1,090
34 CABLES AND CONTROLS 1407	LBS	31 DDTCE CER	15	1.00	28	0	0	0.0	3,965
		UNIT CER	47	1.00	54				3,439
35 AVIONICS		5 DDTCE SUBS	0	0.00	0	0	0	0.0	82,732
		UNIT SUBS	0	0.00	0				56,662
36 G E N. 2255	LBS	35 DDTCE CER	17	1.00	28	0	0	0.0	70,584
		UNIT CER	48	1.00	54				43,142
37 COMMUNICATIONS 2640	LBS	35 DDTCE CER	18	1.00	28	0	0	0.0	7,107
		UNIT CER	49	1.00	54				7,954
38 INSTRUMENTATION 1760	LBS	35 DDTCE CER	18	1.00	28	0	0	0.0	5,039
		UNIT CER	49	1.00	54				5,545
39 ECS		5 DDTCE SUBS	0	0.00	0	0	0	0.0	7,895
		UNIT SUBS	0	0.00	0				2,996
40 TANK PURGE 942	LBS	39 DDTCE CER	4	1.00	28	0	0	0.0	3,796
		UNIT CER	40	1.00	54				297

133

ORIGINAL PAGE IS
OF POOR QUALITY

D180-20689-5

Table 5.3.2-4 (Continued)

41 COMP PAYS 1137	LBS	39 DDTCE CER	29	1.00	28	0	0	0.0		4,098
		UNIT CER	41	1.00	54				1 85	2,698
42 HYDRAULIC SYS 2090	LBS	5 DDTCE CER	6	1.00	28	0	0	0.0		8,549
		UNIT CER	40	1.00	54				1 85	515
43 TPS		0 DDTCE SUBS	0	0.00	0	0	0	0.0		51
		UNIT SUBS	0	0.00	0				0 0	8
44 TPS1 1	LBS	43 DDTCE CER	3	1.00	28	0	0	0.0		6
		UNIT CER	37	1.00	54				1 85	1
45 TPS2 1	LBS	43 DDTCE CER	3	1.00	28	0	0	0.0		6
		UNIT CER	37	1.00	54				1 85	1
46 TPS3 1	LBS	43 DDTCE CER	3	1.00	28	0	0	0.0		6
		UNIT CER	37	1.00	54				1 85	1
47 TPS4 1	LBS	43 DDTCE CER	3	1.00	28	0	0	0.0		6
		UNIT CER	37	1.00	54				1 85	1
48 TPS5 1	LBS	43 DDTCE CER	3	1.00	28	0	0	0.0		6
		UNIT CER	37	1.00	54				1 85	1

134

ORIGINAL PAGE IS
OF POOR QUALITY

D180-20689-5

Table 5.3.2-4 (Continued)

57 FLT TEST HDWE	54 DDTLE FAC UN	5	2.00	0	0	0	0.0		352,455
	UNIT N/A	0	0.00	0				0 0	0
58 SFLI	4 DDTLE CER*	5	0.00	0	0	0	0.0		29,574
	UNIT N/A	29 0	0.00 0.00	0				0 0	0
59 FLT VEH DDCT	0 DDTLE FACTOR	5	1.00	0	0	0	0.0		0
	UNIT N/A	58 55 0	1.00 1.00 0.00	0				0 0	0
60 SOFTWARE ENGR	4 DDTLE CER*	59	0.00	0	0	0	0.0		38,031
	UNIT N/A	33 0	0.00 0.00	0				0 0	0
61 GSE	4 DDTLE CER*	5	0.00	0	0	0	0.0		19,936
	UNIT CER*	56 5 57	0.00 0.00 0.00	0				0 0	22,463
62 FLT TEST DPS	1 DDTLE S	0	0.00	0	0	0	0.0		100,000
	UNIT N/A	0	0.00	0				0 0	0
63	0 DDTLE SUBS	0	0.00	0	0	0	0.0		0
	UNIT SUBS	0	0.00	0				0 0	0
66	0 DDTLE SUBS	0	0.00	0	0	0	0.0		0
	UNIT SUBS	0	0.00	0				0 0	0

5.3.3 External Tank

5.3.3.1 System Description

The current STS External Tank (ET) was modified for the series-burn application. In addition to the propellant load reduction which results in a smaller overall ET, the boost loads are introduced into the aft portion of the LH₂ tank rather than in the intertank region. The overall changes to the ET are noted on Table 5.3.3-1 and the estimated changes in mass are shown. The mass uncertainty of the changes were accounted for as follows:

- 5% uncertainty on deletions
- 10% uncertainty on additions (growth)

TABLE 5.3.3-1 ET MODIFICATIONS AND MASS CHANGES

<u>ELEMENT</u>		<u>MASS CHANGE</u>
LO₂ TANK	(-1350)	
DELETE BARREL		-1069
DECREASE BAFFLES		- 113
DELETE SRB PADUPS		- 168
INTERTANK	(-2726)	
CHANGE MACHINED PANELS - SKIN/STGR		-1631
SHORTEN INTERTANK BY 20"		- 159
CHANGE THRUST FRAME TO STAB. FRAME		- 356
DELETE SRB THRUST BEAM		- 625
DELETE SRB THRUST FITTINGS		- 406
MODIFY SKIN/STRINGER SECTION		+ 514
MODIFY STAB. FRAMES		- 63
LH₂ TANK	(-829)	
DELETE BARREL		-2404
DELETE FRAME XT 1377		- 221
MODIFY STRINGERS & FRAMES		+1697
DELETE SRB FITTINGS		- 100
REDUCE XT 2058 FRAME FOR SRB LOAD		- 181
ADD .81m LOWER SKIRT		+ 380

D180-20689-5

THERMAL PROTECTION	(- 952)	
LO ₂ CRYO REDUCTION		- 85
ABLATION TO CRYO ONLY ON INTERTANK		- 546
LH ₂ CRYO REDUCTION		- 321
PROPULSION & MECH SYSTEMS	(- 160)	
LO ₂ FEEDLINE		- 131
LO ₂ ANTI GEYSER LINE		- 12
LO ₂ PRESS LINE		- 17
ELECTRICAL SYSTEM	(-88)	
SRB WIRING & SHIELDING		- 88
CHANGE UNCERTAINTY	(+ 686)	
UNCERTAINTY ON DELETIONS -5%		+ 427
GROWTH FOR ADDITIONS -10%		+ 259
TOTAL CHANGE - ET INERT WT	<hr/>	-5419
UNUSABLES		
PRESSURANT, GH ₂		- 107
PRESSURANT, GO ₂		- 286
SUPPORTS, SRB GFE		- 231
TOTAL CHANGE ET MECO WT	<hr/>	-6043
REDUCED PROPELLANT	(-160347)	
REDUCED LO ₂		-137440
REDUCED LH ₂		- 22907
TOTAL CHANGE ET LIFTOFF WT.	<hr/>	-166390

5.3.3.2 ET Mass Characteristics

The mass characteristics of the ET reflect the results of incorporating the changes noted in the previous section (5.3.3.1). A mass summary for the External Tank is shown in Table 5.3.3-2.

D180-20689-5

Table 5.3.3-2 External Tank Mass Statement

		KG
Structures		21.146
LO ₂ Tank	4.446	
Intertank	3.276	
LH ₂ Tank	13.424	
Thermal Protection		1.631
Propulsion & Mech. Sys.		1,710
Electrical Sys.		66
ORB Attachments		1.492
Change Uncertainty		686
ET Inert Mass		26.731
Unusables		1.530
ET Meco Mass		28.261

5.3.3.3 ET Cost Estimate

The DDT&E cost estimate for the modifications to the External Tank have been estimated to be \$60M. The initial ET unit cost was determined based on a review of the Shuttle User Charge Policy cost estimates. The Shuttle User Charge policy identifies an ET initial unit cost of \$5.496M (1975\$) and subsequent units based on a 91% improvement curve. These data were escalated to 1977 dollars and the cost impacts due to the modifications assessed. The result is a theoretical first unit cost of \$4.890M. A 91% improvement curve was used to determine the cost of additional units required to satisfy the program requirements.

5.3.4 Vehicle Performance

The personnel carrier vehicle performance was calculated based on the following ground rules:

- Kennedy Space Center (KSC) was the launch site (latitude = 28.5°)
- ΔV Reserves = .85% ΔV_1
- Delivery Orbit
 - Altitude = 477 km circular
 - Inclination = 31°

D180-20689-5

The ascent trajectory characteristics are summarized as follows:

- T/W @ ignition = 1.24
- Maximum Dynamic Pressure = 29.733 kpa
- Maximum Acceleration = 3.0 g's
- Burn Time = 541.9 seconds

The personnel carrier payload performance is summarized in Table 5.3.4-1. A net payload of 73550 kg is delivered to the 477 km orbit. The orbiter events including the suborbital jettison of the ET and the resulting vehicle mass by event are noted on Table 5.3.4-1. The Shuttle orbiter OMS system performs the majority of the orbital maneuvers.

Table 5.3.4-1 Personnel Launch Vehicle Performance Mass Statement

SPS 861

DRY MASS		SECOND STAGE SEQUENCE	
VEHICLE ELEMENT	10 ³ KG	EVENT	MASS AFTER EVENT 10 ³ KG
BOOSTER	(164.68)	STAGE AT MECO	187.29
STRUCTURE	80.52	ΔV RESERVE	183.98
THERMAL PROTECTION SYSTEM	10.41	DROP ET	155.72
LANDING SYSTEM & RCS	5.48	PERIGEE BURN	154.17
ASCENT PROPULSION	47.14	APOGEE CIRCULARIZATION	148.94
PRIME POWER	.82	RCS TRIM	148.05
POWER CONV/DIST	1.73	OMS TRIM	147.54
ECS	.86	DEPLOY PAYLOAD (P/L = 73 550 kg)	73.99
AVIONICS	2.74	DEORBIT ΔV	71.21
GROWTH	14.98		
EXTERNAL TANK	(26.73)		
ORBITER	(68.56)		
DRY MASS =	(269.97)		

5.3.5 Personnel Module

A crew carrying module for transporting personnel in the Shuttle cargo bay has been defined to establish the mass and cost of this element in the Transportation System. The module concept is shown in Figure 5.3.5-1. A crew size of 50 men per flight was baselined for purposes of this study. Four abreast seating on a single level was the selected arrangement. The lower level would be used for life support equipment and baggage.

Mass Characteristics—The mass characteristics of the personnel module are noted on Table 5.3.5-1. These are preliminary estimates based on previous study results and in house IR&D activities.

Table 5.3.5-1 Personnel Module Mass Statement

Module Element	Mass - kg
Cylinder and Bulkheads	2568
Support Structure	681
Airlock and Escape Hatches	1315
Furnishings	1134
Thermal Protection	1905
Life Support	805
Crew and Equipment	7938
Growth - 10%	<u>1590</u>
Total Mass	17896

Cost Estimate—A preliminary cost estimate has been developed for the personnel module using the Boeing Parametric Cost Model (PCM). The DDT&E estimate of \$117.5M includes a single ground test unit. The 1st unit production cost is estimated to be \$24.67M. These costs were developed in the same manner as the launch vehicle costs.

EMPTY MASS	9,958 KG
MASS OF CREW (50)	7,938 KG
TOTAL MASS	17,896 KG

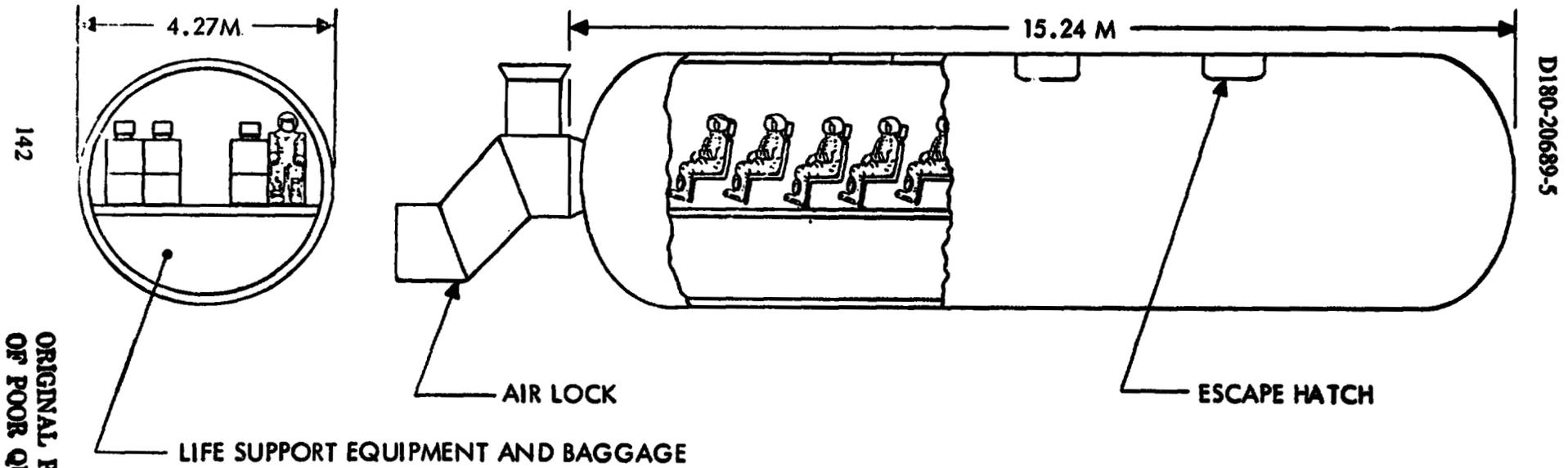

Figure 5.3.5-1 Shuttle Personnel Module

142 ORIGINAL PAGE IS OF POOR QUALITY

D180-20689-5

5.3.6 Personnel Vehicle Cost per Flight

The personnel vehicle cost per flight is based on the cost per flight work breakdown structure shown in Table 5.3.6-1. The average cost/flight is based on a launch rate of 256 flights per year amortized over 14 years of operation. Total program costs less the DDT&E and facilities portion are included in the average cost per flight. The equivalent hardware units to satisfy life, refurbishment and replenishment spares requirements are as follows:

<u>Hardware Element</u>	<u>Equivalent Units</u>
C ₃ H ₈ Booster Airframe	26 units
C ₃ H ₈ Engines	175 units
Orbiters	10 units
SSME's	140 units
ET	3584 units

The average cost of the ten orbiters was established at \$550M each.

The average cost per flight of \$12.619M includes Program Direct (75%), Direct Manpower (12%) and Indirect Manpower (13%) categories. The Program Direct element breakdown is as follows:

Program Support	10%
Production and Spares	36%
Expendable Hardware	20%
Tooling	5%
Ground Operations/Systems	29%

The Direct and Indirect Manpower costs reflect both extrapolation and modification of the Shuttle User charge data for the Personnel Vehicle Concept.

Table 5.3-6-1 Personnel Carrier Average Cost/Flight (256 Flights/Year For 14 Years)

WBS ELEMENT	COST BY WBS LEVEL - \$M (1977 \$)			
	1	2	3	4
TOTAL PROGRAM OPERATING COST	12,619			
PROGRAM DIRECT		9,388		
PROGRAM SUPPORT			0,908	
PRODUCTION & SPARES			3,426	
ORBITER PRODUCTION				1,536
ORBITER SPARES				0,342
SSME'S				0,325
BOOSTER AIRFRAME				0,779
BOOSTER ENGINES				0,280
CREW RELATED GFE				0,165
EXPENDABLE HARDWARE - E.T.			1,858	
TOOLING			0,437	
GROUND OPS/SYS			2,759	
GROUND OPS				1,473
GSE SPARES				0,326
PROPELLANT				0,888
OTHER				0,074
DIRECT MANPOWER :		1,568		
CIVIL SERVICE			0,861	
SUPPORT CONTRACTOR			0,707	
INDIRECT MANPOWER		1,663		
CIVIL SERVICE			0,755	
SUPPORT CONTRACTOR			0,908	

144

ORIGINAL PAGE IS
OF POOR QUALITY

D180-20689-5

5.4 Launch Vehicle Comparison Results

The LEO transportation task addressed the following two major issues:

- 2 Stage ballistic vs. winged freighter
- Impacts of GEO vs. LEO assembly

Cost, performance, and risk are the principal evaluators for comparison purposes.

Ballistic vs. Winged Freighter—A comparison of the DDT&E cost estimates between the two concepts is shown in Figure 5.4-1. The ballistic recoverable vehicle offers an advantage of \$1.5B lower DDT&E cost which translates into the winged freighter being 20% more expensive. The initial production unit cost comparison between the two concepts is shown in Figure 5.4-2. The ballistic recoverable vehicle offers about a \$100M advantage on the initial unit cost or approximately 10% lower than the winged vehicle. Since operations cost is such an overwhelming portion of the life cycle cost the DDT&E advantage for the ballistic vehicle is relatively minor. The cost per flight comparison for GEO Assembly, shown on Figure 5.4-3, results in a 4% advantage for the ballistic recoverable vehicle. The transportation cost (\$/kg) which also includes the effects of the vehicle payload differences are \$15.45/kg for the ballistic and \$20.82/kg for the winged vehicle. The winged concept is about 7% more expensive in delivery cost than the ballistic version. Both concepts appear economically viable and the quantitative differences are not large, resulting in either concept being potential candidate for SPS Freighter.

A number of concerns exist with both concepts that require further investigation and a few are noted below.

<u>Ballistic</u>	<u>Winged</u>
Sea Recovery	Payload Density Achievable
Salt Water Compatibility	Higher DDT&E
Launch Siting	Launch & Booster Recovery Siting

Launch Siting is a common concern due to the high daily launch requirements of between 8 and 12 flights per day. Remote sites may merit consideration for a program as large as SPS.

ORIGINAL PAGE IS
OF POOR QUALITY

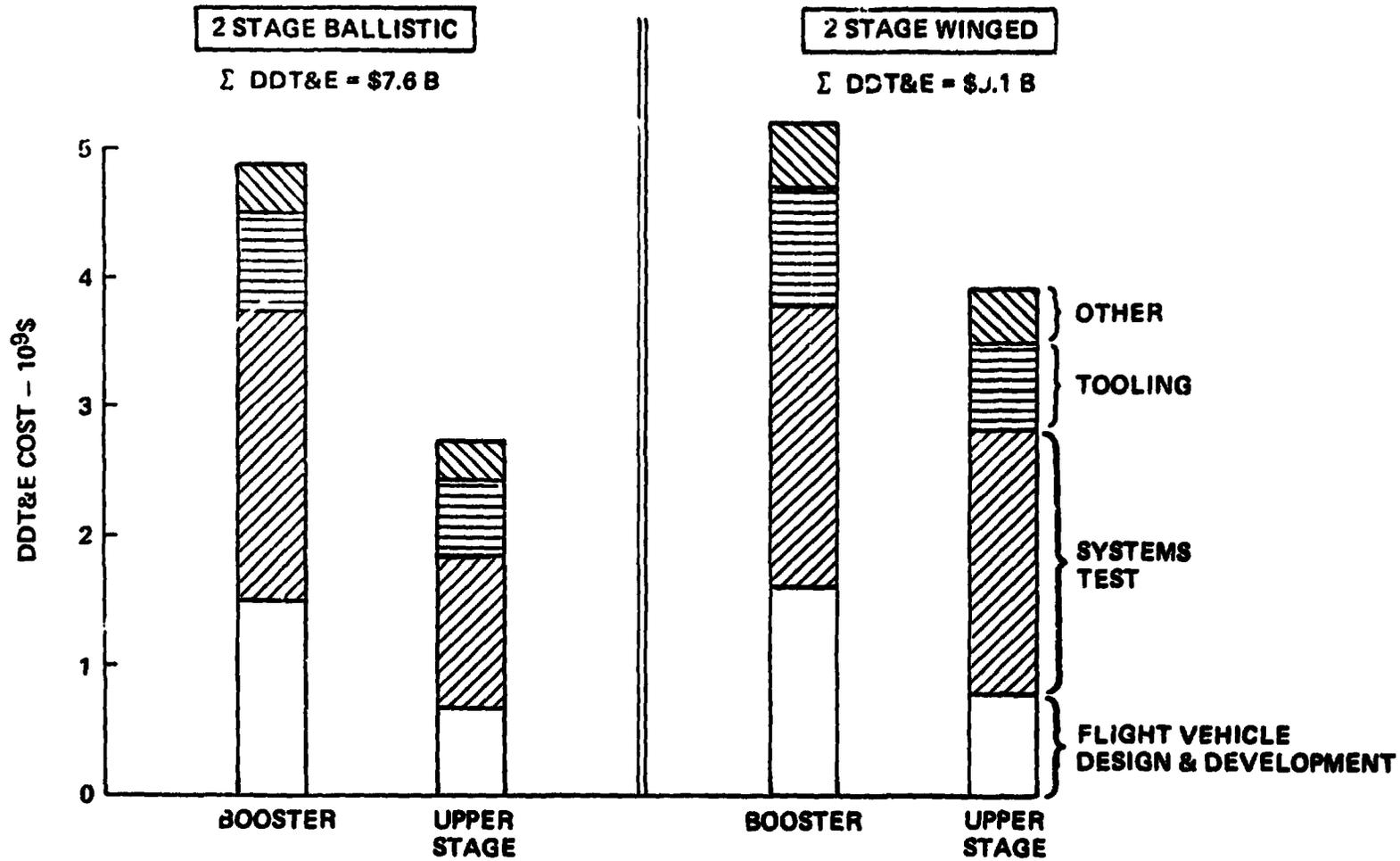

Figure 5.4-1 DDT&E Cost Comparison 2 Stage Ballistic vs Winged

ORIGINAL PAGE IS
OF POOR QUALITY

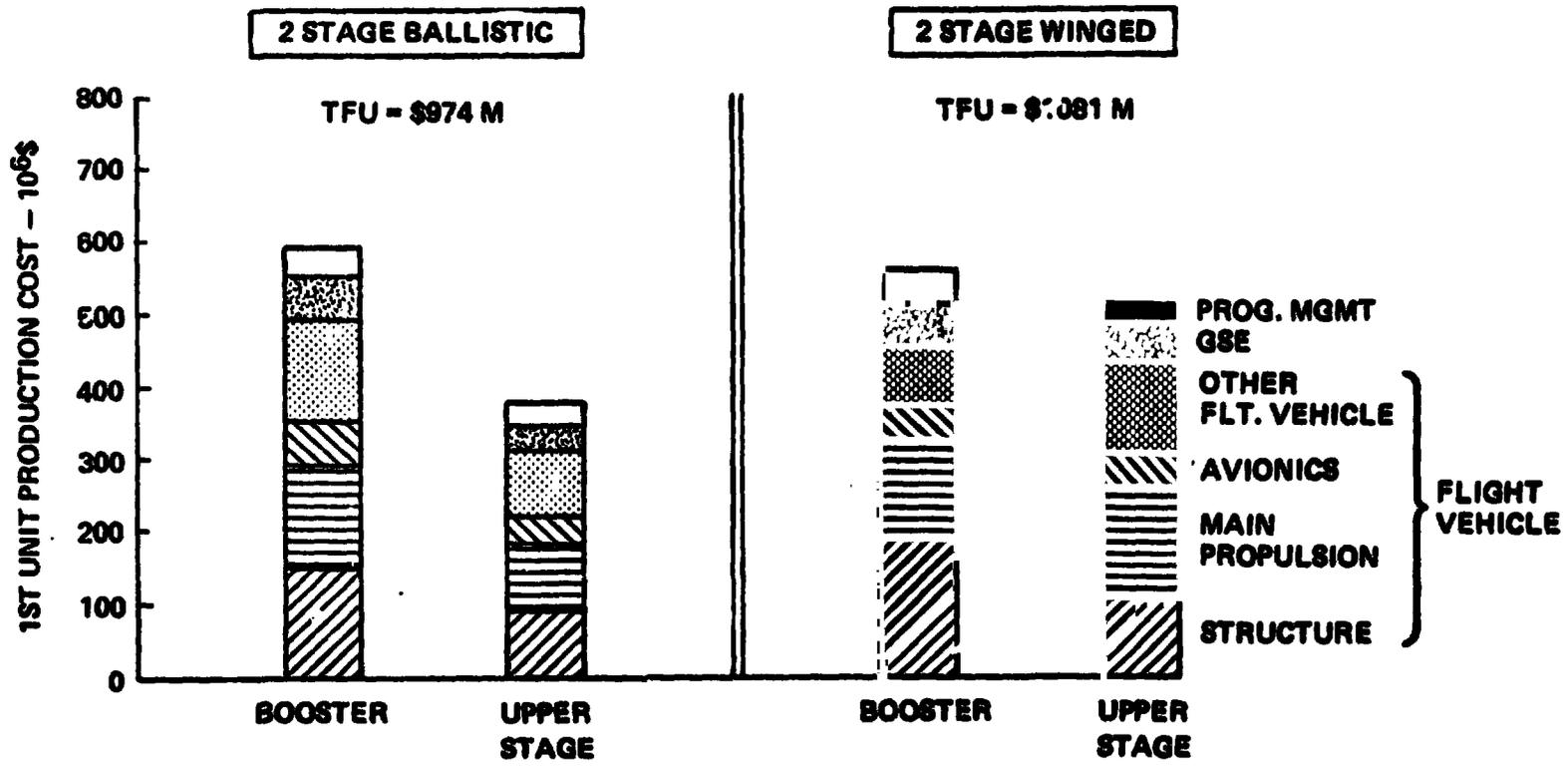

Figure 5.4-2 First Production Unit Cost Comparison

ORIGINAL PAGE IS
OF POOR QUALITY

- 14 YEAR PROGRAM
- 4 SATELLITES/YEAR
- 1977 \$

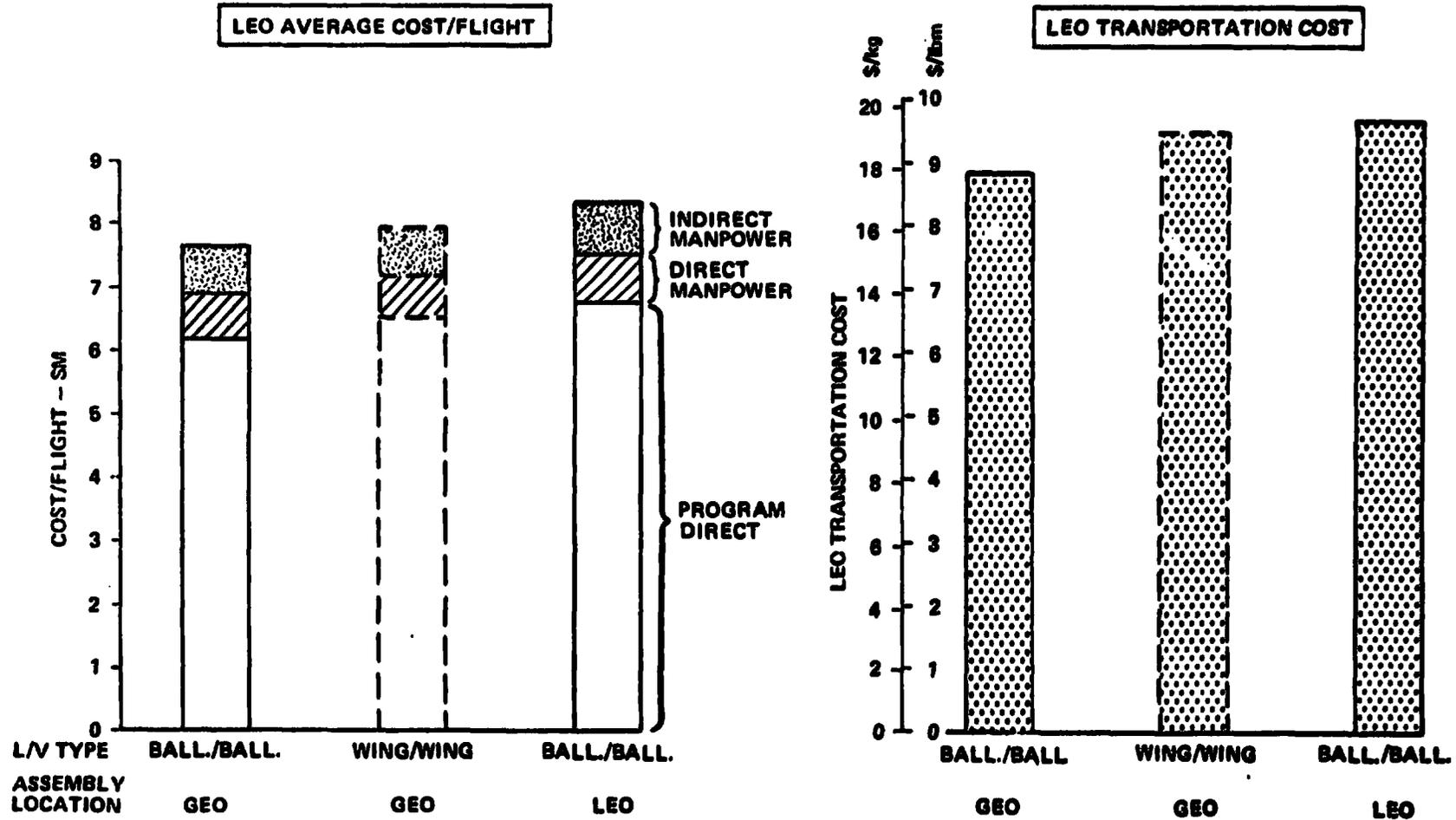
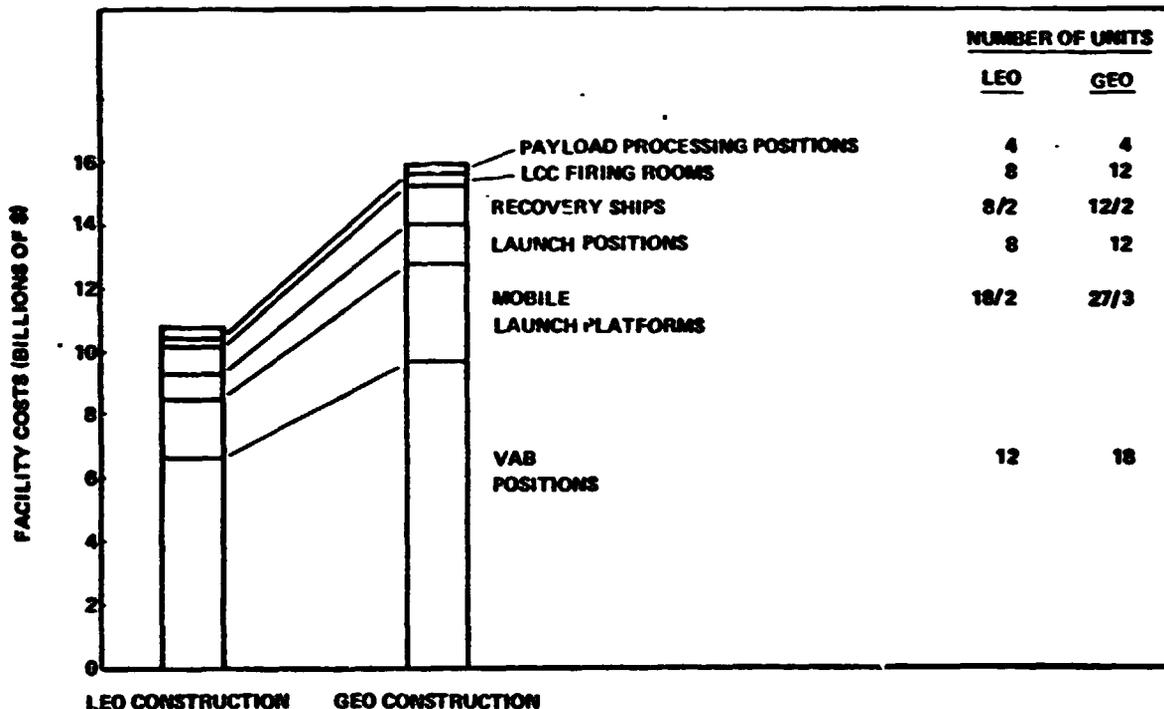

Figure 5.4-3 Comparison of LEO Transportation Costs

LEO vs. GEO Assembly—The annual flight rate of 3125 for GEO assembly and 1875 for LEO assembly to install 4 satellites per year is a major driver in this issue. Using the ballistic recoverable vehicle as reference, the cost/flight and transportation cost to orbit are higher for LEO assembly as shown in Figure 5.4-3. However, even with higher per flight costs the lower flight rate results in a \$2.0B per satellite savings for LEO Transportation.

The launch facility requirements also differ dependent on whether the satellite is assembled in low Earth or geosynchronous orbit. The facility requirements and the estimated facility costs for both assembly options are shown in Figure 5.4-4. The required number of positions and/or units, including spares, are identified in the tabular portion of Figure 5.4-4. A facility cost differential of \$5.2B favoring LEO assembly was identified. Amortizing the \$5.2B over 56 satellites (14 years @ 4 satellites/year) results in a \$0.1B saving per satellite for LEO Assembly. The net advantage for LEO assembly is about \$2.1B/satellite from LEO transportation system considerations.

SPS-662



● Δ COST FOR GEO CONSTRUCTION = \$5.2B

ORIGINAL PAGE IS
OF POOR QUALITY

Figure 5.4-4 Launch Site Differentials Estimated Facility Costs

ORIGINAL PAGE IS
OF POOR QUALITY

TABLE OF CONTENTS

	Page
6.1.1	Satellite OTV 151
6.1.1.1	System Options 151
6.1.1.2	System Description 154
6.1.1.2.1	Configuration 154
6.1.1.2.2	Subsystems 154
6.1.1.2.3	Performance 158
6.1.1.2.4	Mass 158
6.1.1.2.5	Mission Profile and Flight Operations 161
6.1.2	Crew Rotation/Resupply OTV 166
6.1.3	Cost Analysis 166
6.1.3.1	DDTE and TFU Cost 166
6.1.3.2	Cost per Flight 168

150
^
PARK STATIONERY BANK

6.0 ORBIT TRANSFER VEHICLE DESCRIPTION

Orbit transfer vehicles (OTV's) provide the capability to move crews, supplies and SPS components or modules between LEO and GEO. OTV descriptions associated with each of these functions as they apply to the satellite construction location options are discussed.

6.1 GEO CONSTRUCTION OTV'S

6.1.1 Satellite OTV

The function of the satellite OTV is to deliver SPS components from LEO to GEO. Analysis performed in the Future Space Transportation System Analysis (FSTSA) Study (NAS9-14323) compared chemical, nuclear LH₂, nuclear electric and independent solar electric OTV options. A chemical OTV using LO₂/LH₂ propellant was found to be the most desirable based on cost and operational considerations.

The general concept for the GEO construction option when using a chemical orbit transfer vehicle is illustrated in Figure 6.1-1. The initial operations include the use of a space freighter to bring payloads from Earth to a low Earth orbit (LEO) staging depot. The space freighter also brings propellant for orbit transfer vehicles based at the LEO staging depot. Payloads are transferred to the orbit transfer vehicle which in turn delivers the payloads to GEO where the components are then constructed into a power satellite. Following delivery of the components to GEO, the orbit transfer vehicle returns to the LEO staging depot for subsequent reuse.

6.1.1.1 System Options

The FSTSA study also investigated various staging options for a LO₂/LH₂ OTV and found the common two stage vehicle to have the most desirable cost and operational features. Three variations of the common stage vehicle were investigated in Part I of the SPS study and are illustrated in Figure 6.1-2. The basic difference between these options is in the method of propellant handling and whether the OTV is space based or ground based. All options make use of the LEO staging depot. The first option is the space-based version. A two-staged vehicle is used with both stages identical in propellant capacity. Propellant for this system is brought to LEO by a launch vehicle and a tanker with propellant transfer occurring between the tanker and each of the OTV stages. A centrifugal phase separation method is used to transfer propellant. This method consists of having propellant outlets on the tanker wall and circulating some of the pumped propellant back into the tanker in a manner that "swirls" the propellant so it always remains against the wall and consequently can reach the outlet. A 5% propellant loss has been associated with the transfer. The second option, identified as a mission tanker, again makes use of the ground based tanker. However, in this case, the tanker continues throughout the whole mission. Its propulsion systems and avionics are provided in a separate space-based module. Consequently, assembly of the tanker with the propulsion

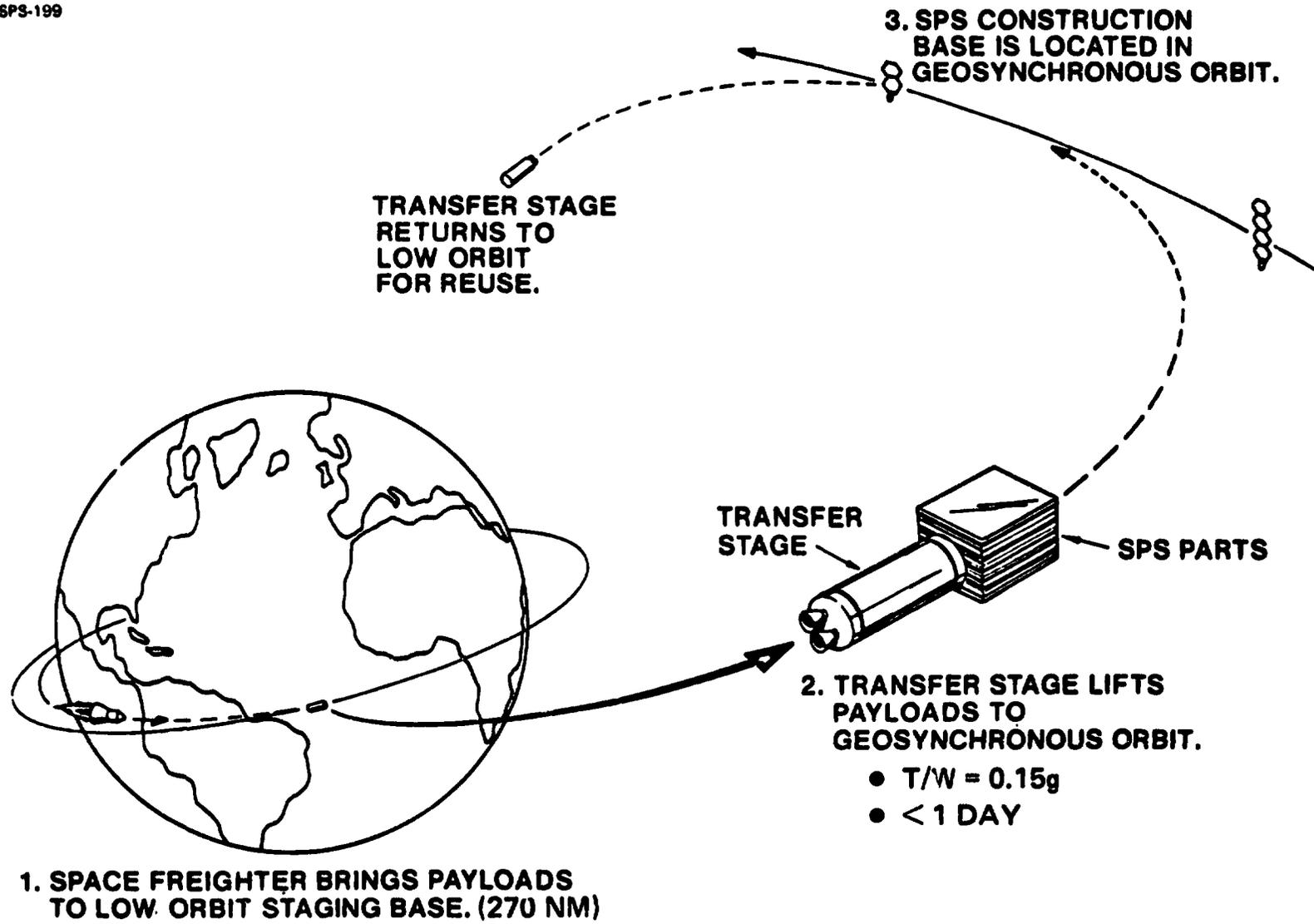

D180-20689-5

152

ORIGINAL PAGE IS OF POOR QUALITY

Figure 6.1-1 Chemical Orbit Transfer Operations GEO Construction

SPACE BASED

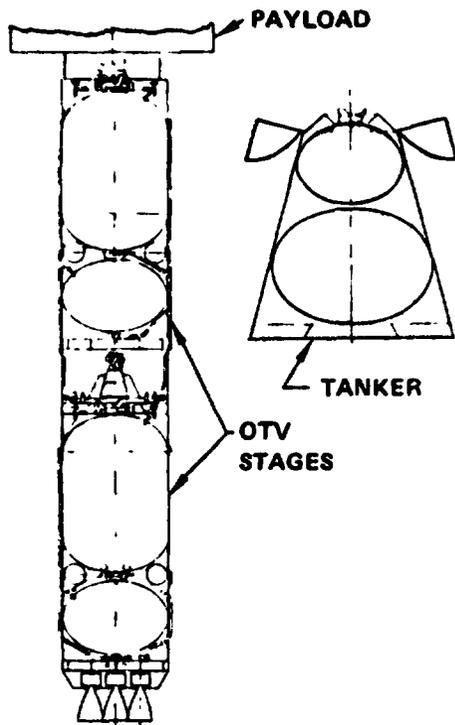

- SPACE BASED OTV
- GROUND BASED TANKER
- PROPELLANT TRANSFER (TANKER - OTV)
- OTV ASSEMBLY

MISSION TANKER

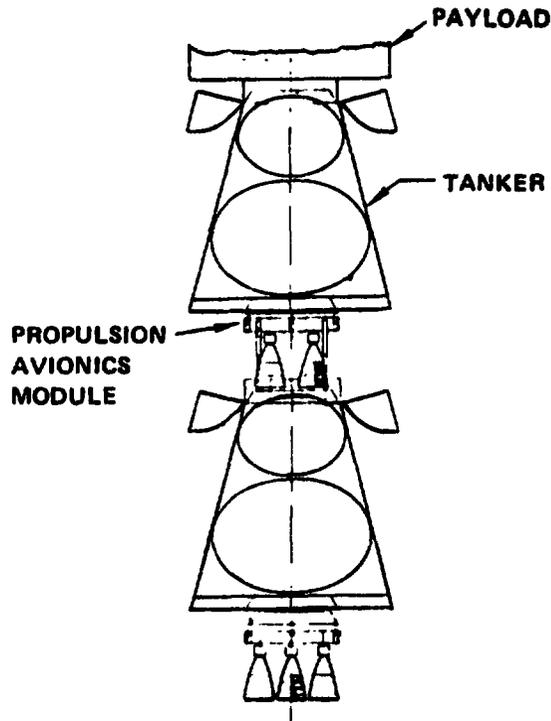

- SPACE BASED
- PROPULSION MODULE
- GROUND BASED TANKER
- STAGE ASSEMBLY
- OTV ASSEMBLY

TANKER OTV

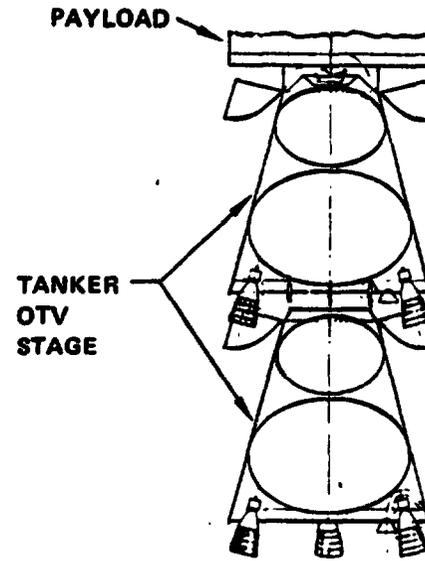

- GROUND BASED OTV
- OTV ASSEMBLY

Figure 6.1-2 LO₂/LH₂ OTV Options

D180-20689-5

module is required for each stage; however, no propellant transfer is required. The third option, identified as a tanker OTV, is actually a ground-based orbit transfer vehicle. Again, a tanker is used, but in this case the engines and avionics are integrated directly into the tanker system and no propellant transfer or assembly of the stage is required. Preliminary analysis indicated the mission tanker has considerably more operational complexity than the tanker OTV. Consequently, the mission tanker was not included in performance and cost comparisons.

Comparisons of the space based and tanker OTV options for performance, the number of Earth launches required, and resulting satellite transportation costs are shown in Figure 6.1-3. The tanker OTV option required approximately 100,000 kilograms additional vehicle startburn mass, primarily as a result of the additional propellant associated with the additional structure and thermal control systems for that vehicle. This additional mass, in turn, translates into additional Earth launches required as indicated by the middle bar graph. When expressed as transportation costs for one satellite including both the launch vehicle and the orbit transfer operations, the tanker OTV results in about a 10% penalty over the space-based OTV. Consequently, the space based OTV was selected as the reference LO_2/LH_2 system.

6.1.1.2 System Description

6.1.1.2.1 Configuration

The space-based common stage OTV is a two-stage system with both stages having identical propellant capacity as shown in Figure 6.1-4. The first stage provides approximately 2/3 of the delta V requirement for boost out of low Earth orbit at which point it is jettisoned for return to the low Earth orbit staging depot.

The second stage completes the boost from low Earth orbit as well as the remainder of the other delta V requirements to place the payload at GEO and also provides the required delta V to return the stage to the LEO staging depot. Subsystems for each stage are identical in design approach. The primary difference is the use of four engines in the first stage due to thrust-to-weight requirements. Also, the second stage requires additional auxiliary propulsion due to its maneuvering requirements including docking of the payload to the construction base at GEO. The vehicle has been sized to deliver a payload of 400,000 kilograms. As a result, the stage startburn mass without payload is approximately 890,000 kilograms with the vehicle having an overall length of 56 meters.

6.1.1.2.2 Subsystems

Structure and Mechanisms

Main propellant containers are welded aluminum with integral stiffening as required to carry flight loads. Intertank, forward and aft skirts, and thrust structures employ graphite/epoxy composites. An Apollo/Soyuz type docking system is provided at the front end of each stage for docking with

ORIGINAL PAGE IS
OF POOR QUALITY

ORIGINAL PAGE IS
OF POOR QUALITY

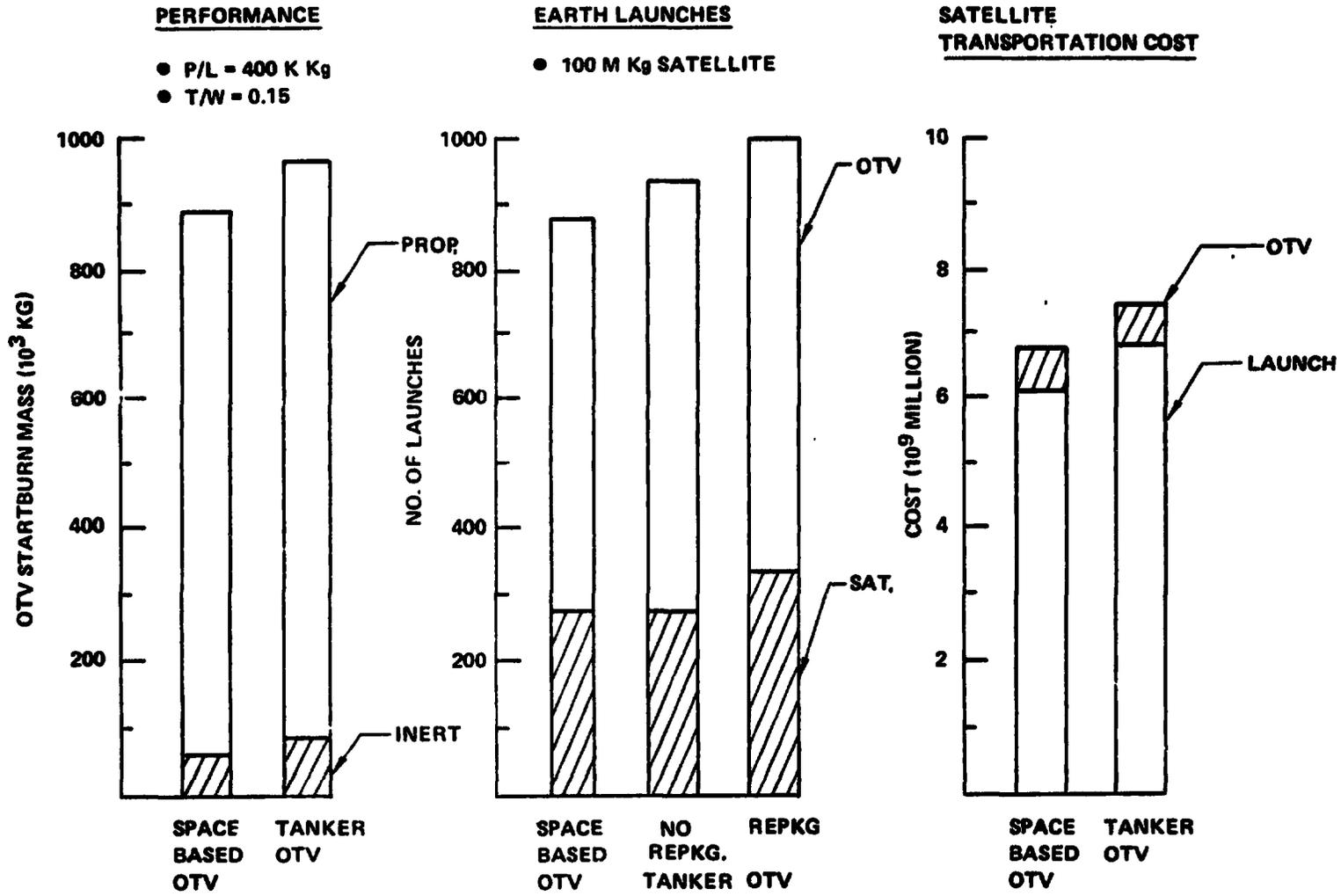
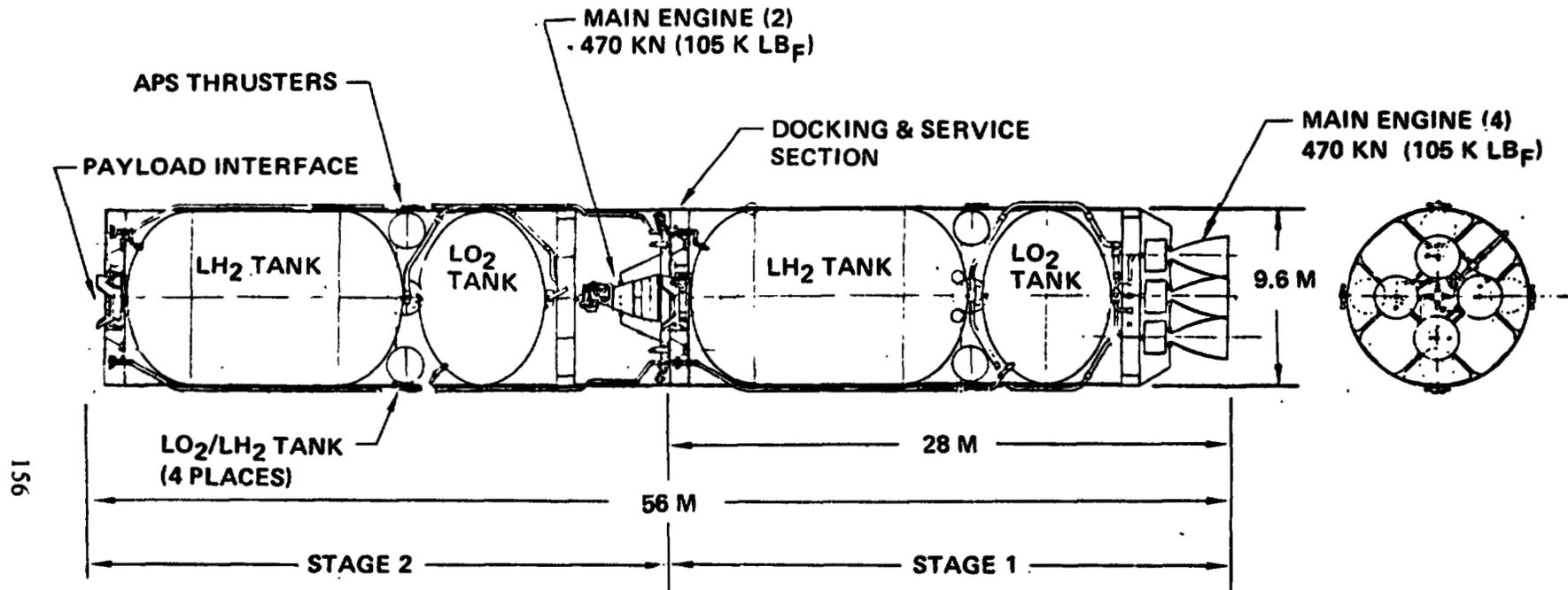

Figure 6.1-3 LO₂/LH₂ OTV Comparison

SPS-203



D180-20689-5

- PAYLOAD CAPABILITY = 400,000 KG
- OTV STARTBURN MASS = 890,000 KG
- STAGE CHARACTERISTICS (EACH
 - PROPELLANT = 415,000 KG
 - INERTS = 29,000 KG (INCLUDING NONIMPULSE PROPELLANT)
- 280 OTV FLIGHTS PER SATELLITE

Figure 6.1-4 Space Based Common Stage OTV
GEO Construction

Thermal/Environment Control

Main propellant tanks are insulated by aluminized mylar multilayer insulations contained within a purge bag. The insulation system is helium purged on the ground and during Earth launch. The avionics systems employ semi-active louvered radiators and cold plates. Active fluid loops and radiators are required for the fuel cell systems. Superalloy metal base heat shields are employed to protect the base areas from recirculating engine plume gas.

6.1.1.2.3 Performance

Performance characteristics associated with the common stage LO₂/LH₂ OTV is shown in Figure 6.1-5. Propellant requirements are shown as a function of the payload return capability with the payload delivery requirement fixed at 400,000 kg since that was the reference launch vehicle capability and a minimum amount of payload handling was considered desirable. Performance ground-rules in addition to those shown are as follows:

- THI mode
 - Stg 1 – 100 kg per start
 - Stg 2 – 50 kg per start
- Stop loss
 - Stg 1 – 20 kg
 - Stg 2 – 10 kg
- Boiloff rate
 - 6 kg/hr each stage
- Burnout mass scaling equations:
 - Stg 1 3430 kg + 0.05567 WP₁ + 0.1725 WP₂
 - Stg 2 3800 kg + 0.05317 WP₁ + 0.1725 WP₂

Where WP₁ and WP₂ are main and auxiliary propellant capacities respectively.

The Part 1 analyses assumed no payload would be returned by the vehicle resulting in a propellant loading of 415,000 kg per stage. Part 2 investigations will consider the situation of 10% of the total mass delivered to orbit will be containers for components, etc., and will eventually require some form of disposal. Should this mass (10%) be returned on a per flight basis, it results in a propellant loading of an additional 100,000 kg per stage. This approach as well as dedicated disposal flights will be investigated in Part 2 of the SPS study.

6.1.1.2.4 Mass

Summary level mass estimates are presented in Table 6.1-1 for the selected satellite OTV. A weight growth factor of 10% was used rather than 15% as in FSTS based on the judgment that the SPS LO₂/LH₂ OTV would be a second generation vehicle. Mass estimates for the systems reflect the design approach previously described.

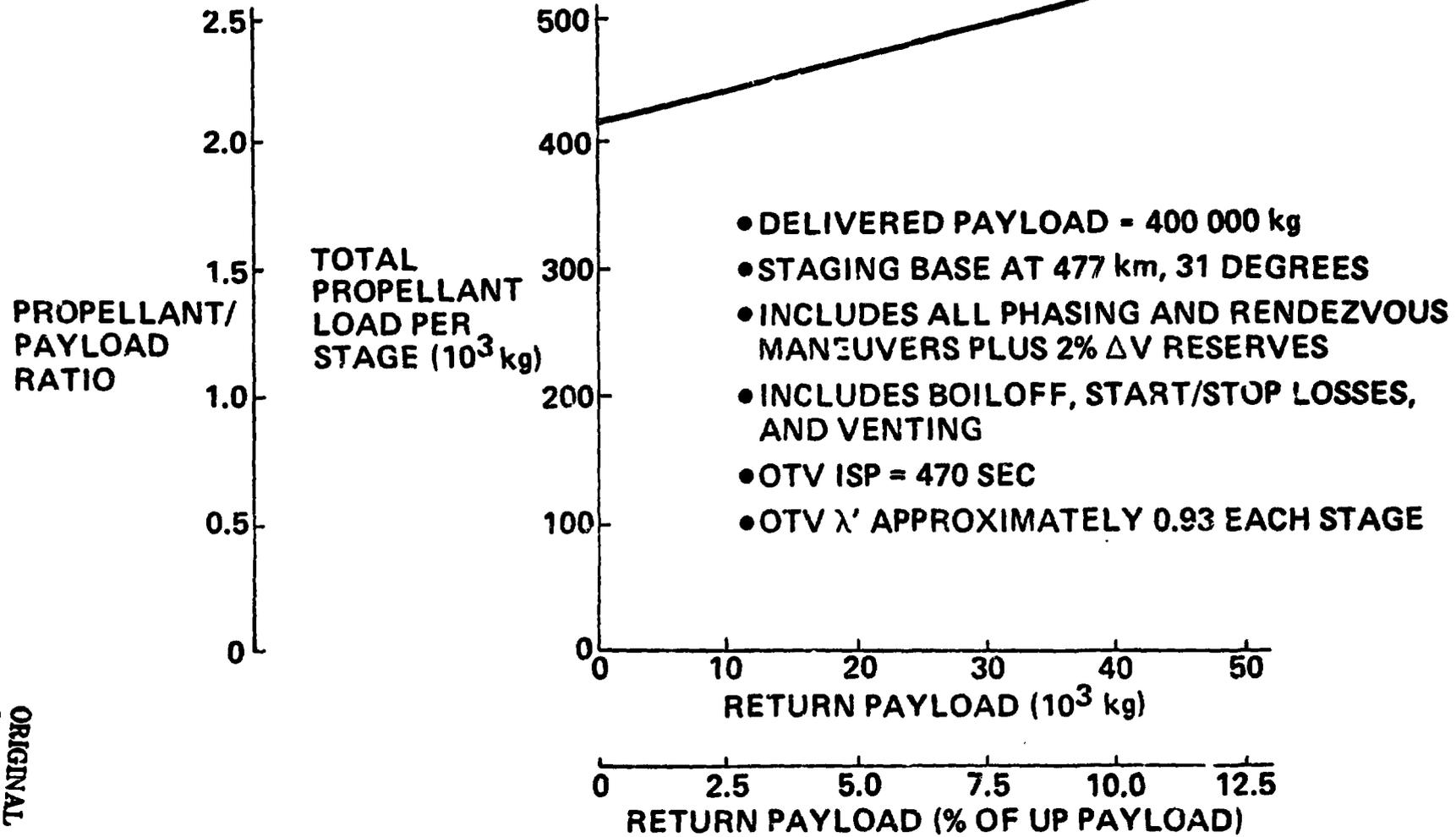

Figure 6.1-5 GEO Construction LO₂/I - OTV Performance

Table 6.1-1 Chemical OTV Mass Summary

	Stage 1 (KG)	Stage 2 (KG)
Struct & Mechanisms	13,300	14,870
Main Propulsion	7,090	4,020
Auxiliary Propulsion	820	1,120
Avionics	300	310
Electrical Power	850	820
Thermal Control	1,850	2,310
Weight Growth (10%)	2,420	2,340
Dry	26,630	25,790
Fuel Bias	640	640
Unusable LO ₂ /LH ₂	1,810	1,810
Unusable & Reserve APS	290	660
Burnout	29,370	28,990
Main Impulse Prop	415,000	407,000
APS	2,700	6,100
Startburn	447,070	442,090

6.1.1.2.5 Mission Profile and Flight Operations

Typical orbit transfer operations from LEO to GEO for the common stage OTV are illustrated in Figure 6.1-6. The majority of the delta V for boosting from LEO is provided by Stage 1. Stage 1 then separates and returns to the staging depot following an elliptical return phasing orbit. Stage 2 completes the boost and puts the payload into a GEO transfer and phasing orbit, as well as injecting the payload into GEO and performing the terminal rendezvous maneuver with the GEO construction base. Following removal of the payload, stage 2 uses two primary burns in returning to the LEO staging depot. A detail mission profile indicating events, time and delta V is presented in Table 6.1-2. A time history of the vehicle mass throughout the flight is presented in Table 6.1-3.

A total elapsed timeline for each stage is presented in Figure 6.1-7. Allowing approximately eight hours for refueling and refurb results in 40 hours elapsed time before a given Stage 1 can be reused. A typical Stage 2, however, has an elapsed time of 85 hours before reuse including time for assembly between stages and between OTV and payload.

With the indicated turnaround times for each stage of an OTV it is possible to establish the total stage fleet size as shown in Figure 6.1-8. The first two bars are associated with the first OTV flight. At the end of approximately 12 hours the second or upper stage (UI) separates from the first (lower) stage (LI). The first stage completes its operations and is available in time for the third OTV

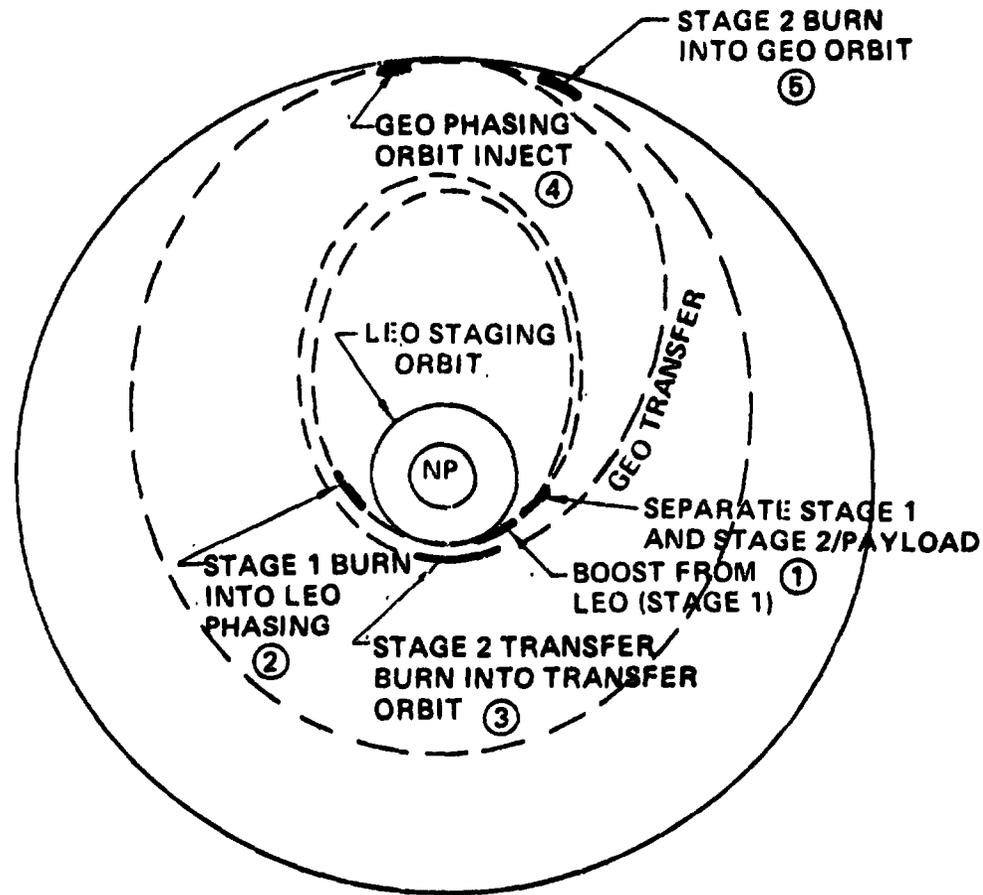

Figure 6.1-6: Chemical OTV Orbit Transfer Operations

DI80-20689-5

Table 6.1-3 (cont) Mass History - Booster Recovery (Stage 1)

TRANSPORTATION SEQUENCE SUMMARY								
SI UNITS								
MANEUVER	EVENT	TIME FROM START	DELTA-V	STG NO.	PROP NO.	IMPULSE PROPELLANT	OTHER MASS EXP	MASS LEFT
INITIAL MASS		0						0
ADD STG 1 ADD STG FUEL							27 172 14 597	27 172 41 769
COAST		4.1	30	1	2	576	25	41 106
PHASE INJECT	VENT	4.2	2 645	1	1	12 327	120 100	26 721 28 021
PHASE		16.2	3	1	2	34	70	28 510
TPI		16.5	50	1	1	300	120	28 483
RENDEZVOUS		16.3	20	1	2	259	12	27 812
DOCK		19.3	10	1	2	120	0	27 690
RESERVE	DRUP STG 1	19.3	85	1	1	500	0	27 172
							27 172	0

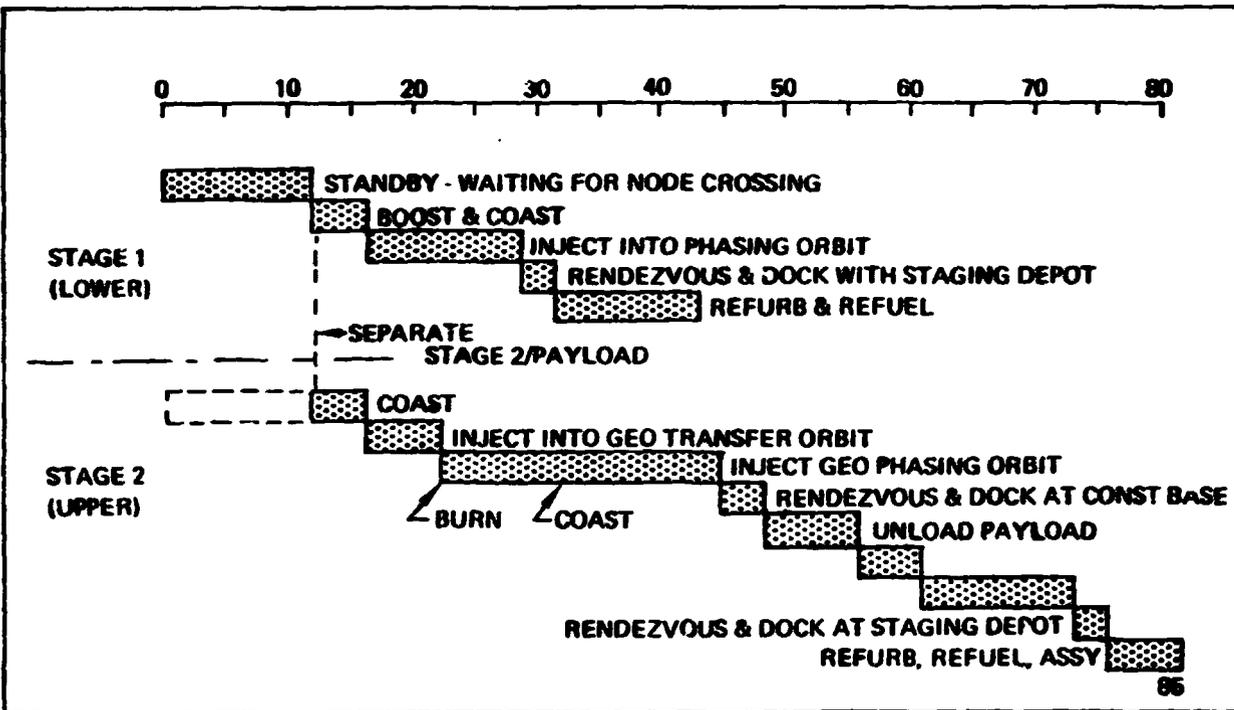

Figure 6.1 - 7 Chemical OTV Flight Operation Timeline

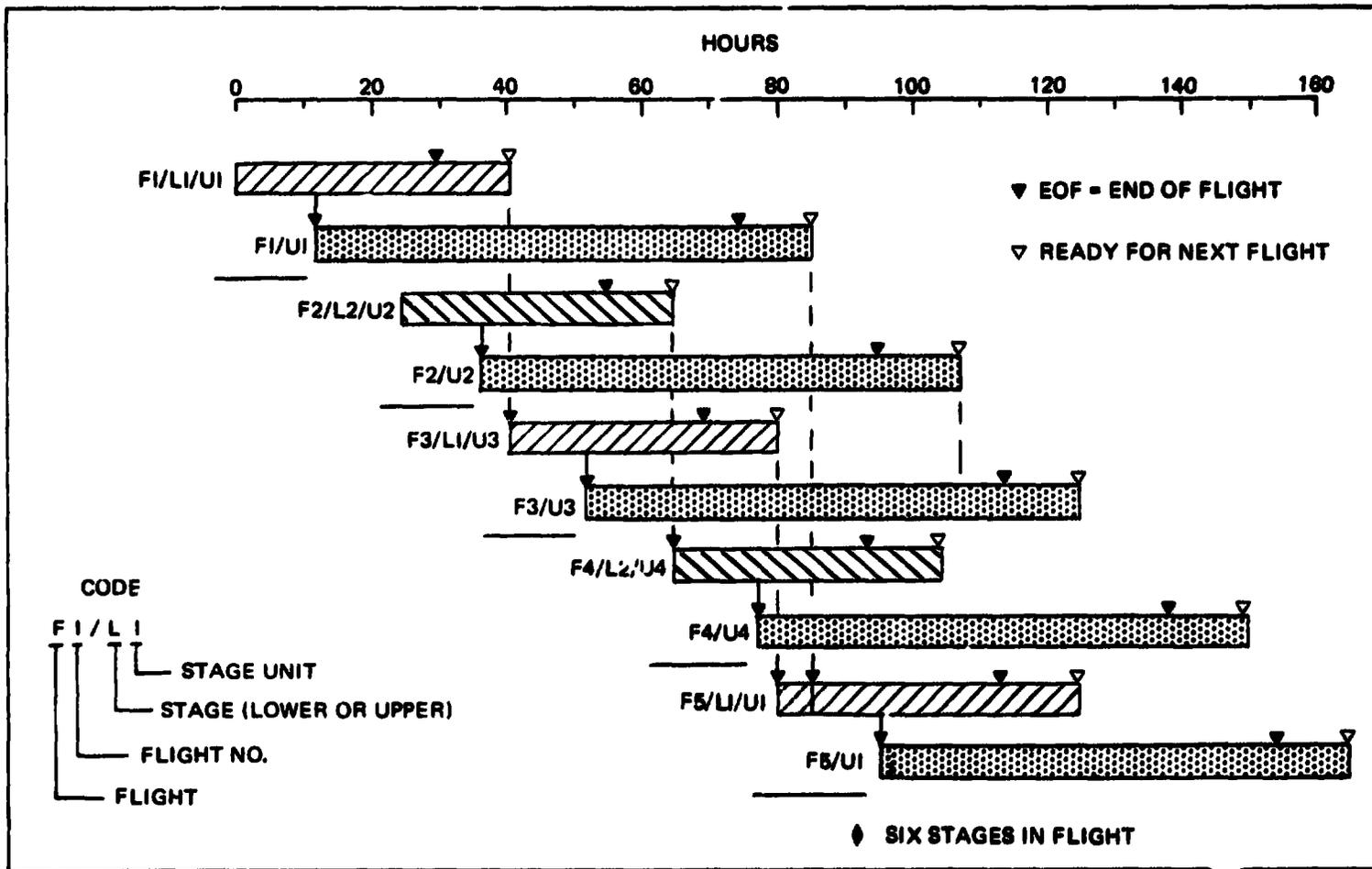

Figure 6.1-8 Chemical OTV Fleet Operations
GEO Construction

flight. The first upper stage finishes its mission and is available for another flight at the end of approximately 85 hours which allows it to be used on the flight scheduled for the fifth day. With operations conducted in this manner and the requirements for one OTV flight per day for five consecutive days per week (corresponds to launch vehicle operations) a total of two lower and four upper stages are required in the fleet in order to conduct day to day operations.

Another observation from Figure 6.1-8 is that at certain points in time. i.e., 95 hours, a maximum of six OTV stages are in flight at one time for each satellite being constructed.

6.1.2 Crew Rotation/Resupply OTV

The requirements and implementation methods for crew rotation/resupply are shown in Figure 6.1-9. The primary requirements are the support of 100 men at LEO staging depot and 700 men at the GEO construction facility with crew stay times of 90 days. Supply requirements are 200 kg per man month including those for the base. Delivery of the crew to the LEO staging depot uses the shuttle growth launch vehicle with the delivery of 50 men per flight. Two launch flights are required to support a crew OTV flight.

Delivery of the crew between LEO and GEO makes use of one stage of the two-stage orbit transfer vehicle that was used for SPS delivery. A total of 28 flights per year are required to change crews. Propellant for the orbit transfer vehicle is delivered by the SPS HLLV. Supplies will also be delivered to the LEO staging depot using the SPS HLLV. The majority of these supplies will in turn be delivered to the GEO construction facility using the two-stage SPS OTV; six flights per year are required for the delivery to GEO. Again, propellant for the orbit transfer vehicle will be delivered to the LEO staging depot using the SPS HLLV.

System descriptions, performance and mass characteristics are the same as described for the satellite OTV.

6.1.3 Cost Analysis

Since the same type of OTV is used for the delivery of SPS components and crew rotation/resupply, cost characteristics can be defined for one size of vehicle and for the total quantity of stages required.

6.1.3.1 DDTE and TFU Cost

DDTE cost for the common stage LO₂/LH₂ OTV with a start burn mass of 900,000 kg is estimated at \$950 million (1977 dollars) based on cost curves developed in the FSTSA study. The average TFU cost for the two stages is estimated at \$82 million (1977 dollars) again using FSTSA curves.

ORIGINAL PAGE IS
OF POOR QUALITY

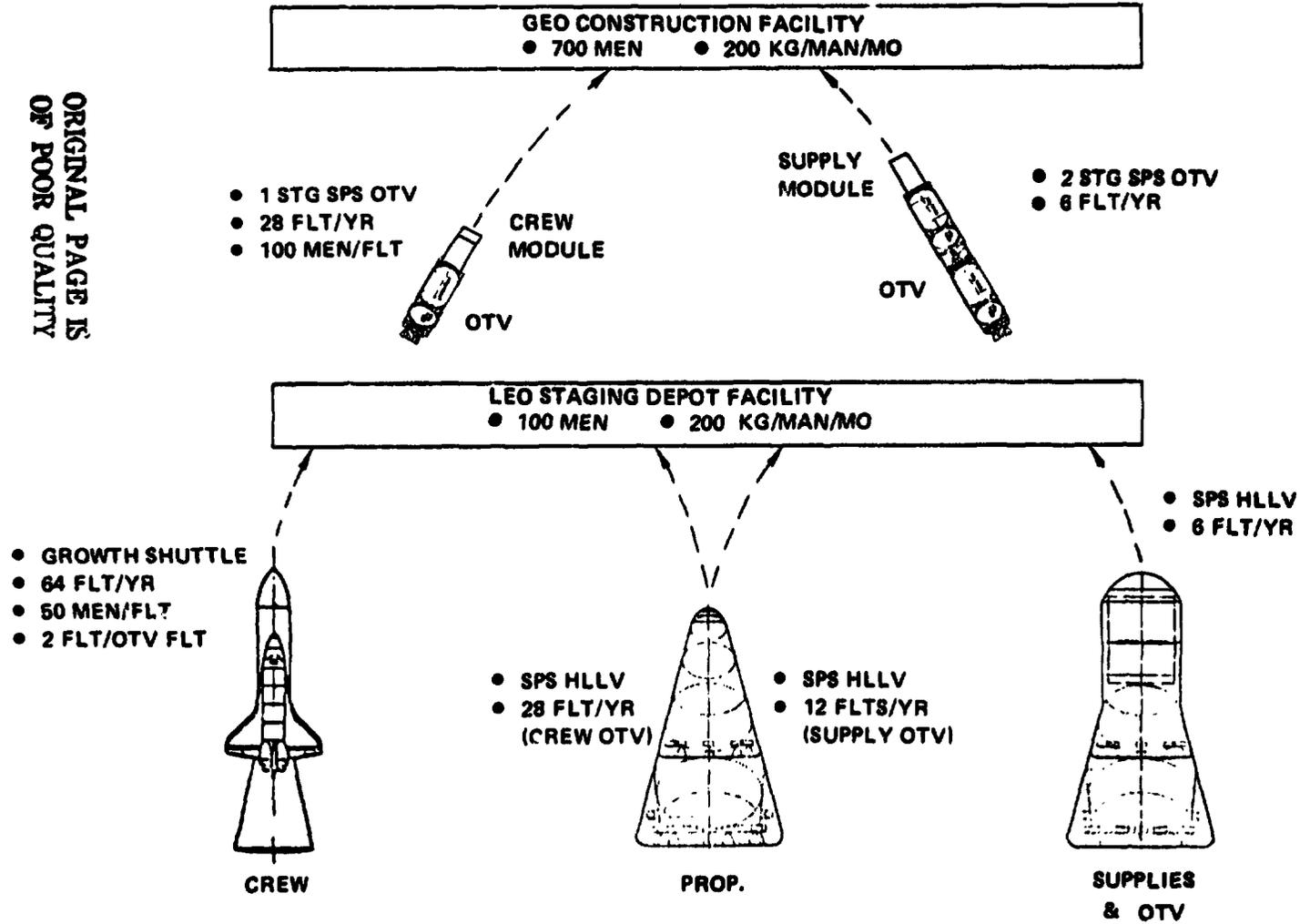

Figure 6.1-9 Crew Rotation/Resupply
GEO Construction/Photovoltaic Satellite

6.1.3.2 Cost Per Flight

The ground rules used to establish the cost per flight of the chemical orbit transfer vehicle are as follows:

- Space Based LO₂/LH₂ Common Stage
- Startburn Stage Mass of 445 K kg
- Stage TFU Equal \$82M (1977 Dollars)
- 280 OTV Flights Per Satellite
- 4 Satellites Constructed Per Year
- 14 Year Program Life
- 50 Flight Design Life
- Stage Learning Factor of 0.88
- LO₂/LH₂ Bulk Cost of \$0.10 per kg
- Spares Equal 50% of Operational Units

The majority of these ground rules are self-explanatory. However, several merit further explanation. The 280 flights for the orbit transfer vehicle is the number required for one satellite. A 14-year program has been assumed for the orbit transfer vehicle, since beyond that point in time it is generally assumed that a different generation of orbit transfer vehicle would be developed. A 50-flight design life has been assumed for the space based orbit transfer vehicle. This value is based on the MSFC Tug Study which assumed 50 uses for a ground based system. Assuming that the SPS OTV is a second generation vehicle, it was assumed 50 uses could be projected for a space based system.

Based on the above ground rules a total of 624 stages (upper and lower) are required resulting in an average stage cost of approximately \$31 million. Cost per flight for a complete two stage OTV was estimated as \$2.26 million with the following breakdown.

- | | |
|---------------------|---------|
| ● Operational Units | \$1.24M |
| ● Propellant | \$0.40M |
| ● Spares | \$0.62M |

TABLE OF CONTENTS

	Page
6.2.1 Satellite OTV	169
6.2.1.1 System Options	170
6.2.1.2 System Description	170
6.2.1.2.1 Reference Photovoltaic Satellite Transfer	170
6.2.1.2.1.1 Configuration	170
6.2.1.2.1.2 Subsystems	172
6.2.1.2.1.3 Performance Optimization	190
6.2.1.2.1.4 Mass	193
6.2.1.2.1.5 Mission Profile and Flight Operation	193
6.2.1.2.1.6 Cost Analysis	200
6.2.1.2.2 Transfer of Other Photovoltaic Satellites	208
6.2.1.2.3 Thermal Engine Satellite Transfer	211
6.2.1.2.3.1 Configuration	211
6.2.1.2.3.2 Subsystems	211
6.2.1.2.3.3 Performance Optimization	211
6.2.1.2.3.4 Mass Summary	214
6.2.1.2.3.5 Mission Profile and Flight Operations	214
6.2.1.2.3.6 Cost Analysis	215
6.2.2 Crew Rotation/Resupply OTV	220

6.2 LEO CONSTRUCTION OTV'S

6.2.1 Satellite OTV

Construction of the satellite or satellite modules in LEO enables the generation of large quantities of electric power and consequently the use of high performance electric propulsion for orbit transfer. The major operations associated with the use of an electric propulsion system in the transfer of satellite modules from LEO to GEO are indicated in Figure 6.2-1. Orbit transfer in this option will be done at acceleration levels of 10^{-4} to 10^{-5} g's and result in trip times as long as six months to one year depending on the optimization criteria used in the analysis. After the modules arrive at GEO, they then must be assembled into the final satellite configuration.

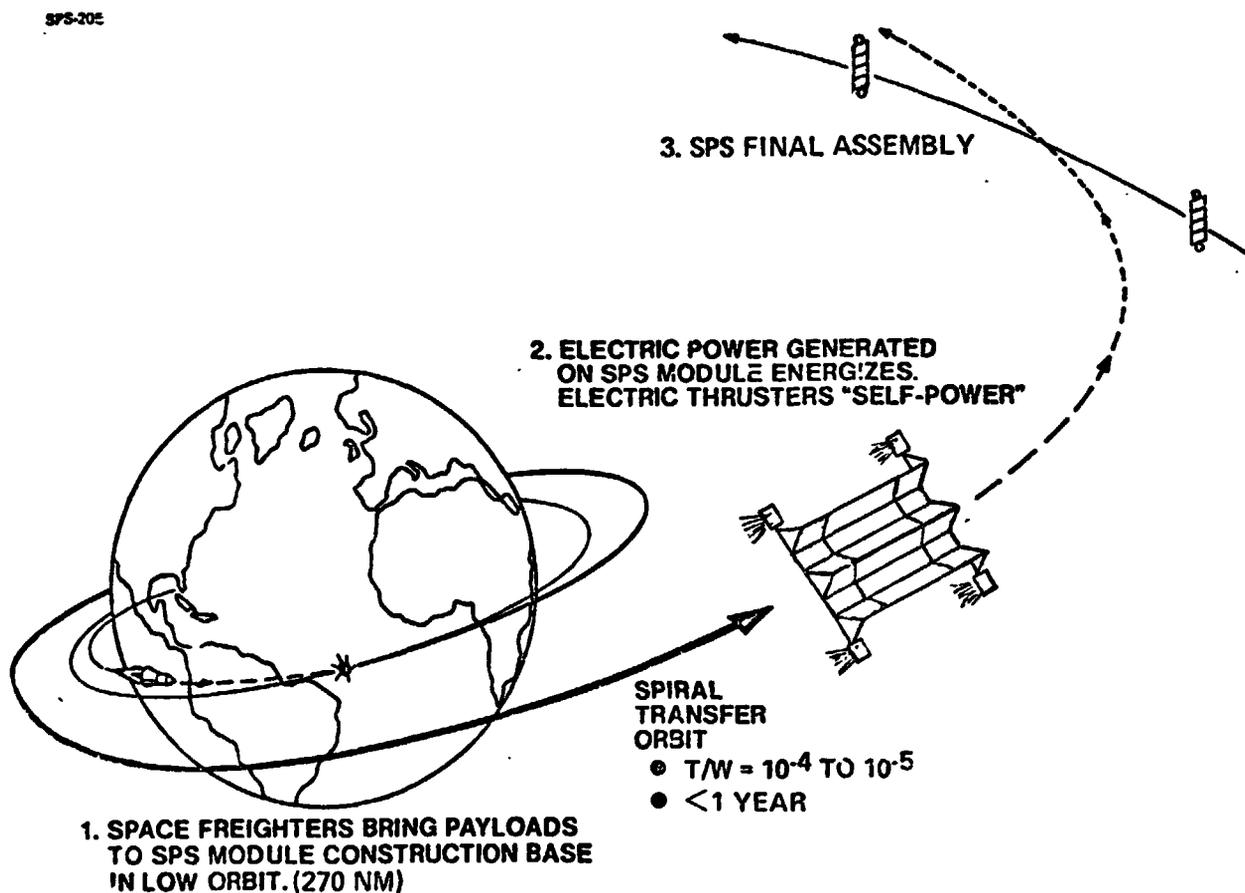

Figure 6.2-1 Electric Propulsion Orbit Transfer Operations LEO Construction

6.2.1.1 System Options

The FSTSA study investigated several types of electric propulsion devices including resistojets, arc-jets, ion jets and MPD jets. The results of that analysis indicated the ion and MPD devices offered the most promise for power satellite application because of their higher performance characteristics.

Further investigations in the early phases of the SPS Part 1 effort indicated the design, performance and operating characteristics of the ion jet to be better understood at this time and, consequently, this concept was selected as the reference electric propulsion thruster.

6.2.1.2 System Description

The system characteristics associated with an electric propulsion system varies to some degree with the type of satellite being transferred (i.e., photovoltaic non-annealing vs annealable, thermal engine). These variations occur in terms of the sensitivity of the power generation system to radiation degradation, the power generation characteristics and flight control characteristics. Consequently, separate orbit transfer discussions are provided for several types of satellites.

6.2.1.2.1 Reference Photovoltaic Satellite Transfer

The reference photovoltaic satellite uses non-annealable silicon solar cells with a concentration ratio of 2 and is designed for 10 GW_e ground output at beginning of life (BOL).

6.2.1.2.1.1 Configuration

The configuration arrangement of the system elements used in the transfer of each satellite module is shown in Figure 6.2-2. The characteristics indicated reflect a transfer time of 180 days which relates to thrust levels required for control purposes and an Isp of 5000 seconds which resulted in the least cost system. The satellite module itself requires oversizing due to the radiation degradation of the solar blankets during the transfer through the Van Allen belts. Approximately 22% of the solar blankets and reflectors are deployed to provide 240,000 kW to the electric thrusters and to compensate for the various losses that occur. The remainder of the blankets and reflectors are deployed once the satellite reaches GEO.

Thruster panels are located at four corners of the module to provide the most effective thrust vector and satisfy control requirements. (Further discussion concerning thrust vector control is found under the flight control paragraph.) Each of the four thruster panels contain 780 thrusters and 10 power processing units (PPU). A two axis gimbal system correctly positions the panel. Installation of the thruster panel approximately 500 meters from the satellite in conjunction with gimbal limits prevents high velocity ions from impinging on the satellite and causing erosion. (Further discussion on the ion impingement erosion condition is present at the conclusion of this section.) Propellant

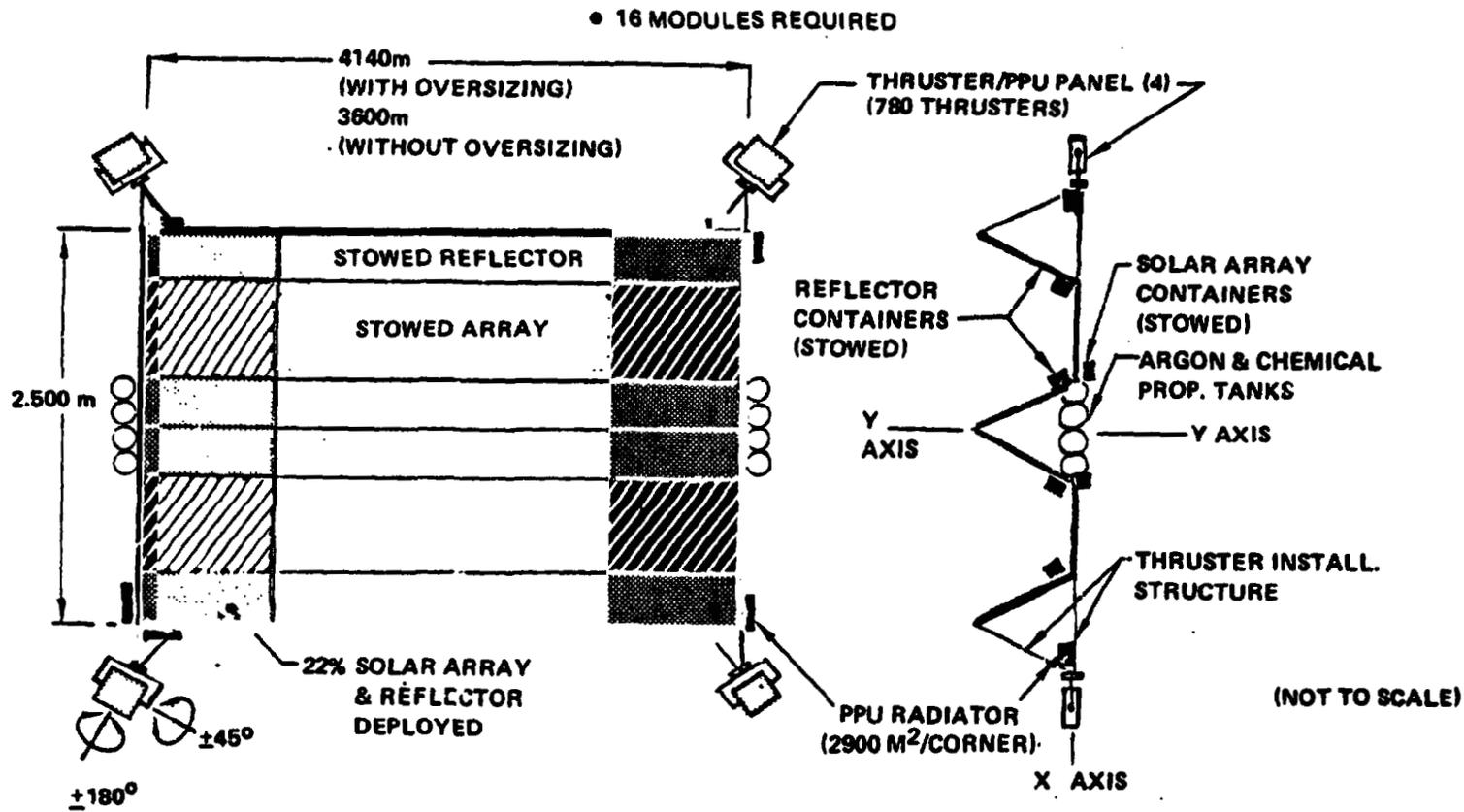

D180-20689-5

MASS PROPERTIES SUMMARY

<u>SATELLITE MODULE</u> (10 ⁶ Kg)		<u>ORBIT TRANSFER SYSTEM</u> (10 ⁶ Kg)	
● BASIC	5.56	● DRY	0.71
● SELF POWER	1.0	● ARGON PROP.	1.52
MODIFICATIONS		● LO ₂ /LH ₂ PROP.	0.38
● I _{yy} -I _{xx} = 3.78 X 10 ¹² KgM			

Figure 6.2-2 Typical Ion Electric Propulsion Configuration Photovoltaic Satellite (10 GW BOL)

D180-20689-5

tanks for thrusters have been located along the center line of the vehicle to provide a more desirable inertia characteristic (the dominating factor in the amount of gravity gradient torque). Radiators dissipate the waste heat from the power processing units. The mass associated with the electric propulsion system consists of approximately one million kilograms for the oversizing and power distribution, while the orbit transfer system has a dry mass of approximately 0.7 million kilograms and approximately 1.9 million kilograms of argon propellant for the electric thrusters and LO_2/LH_2 propellant for attitude control during the occultation periods.

Sputtering Erosion

As previously mentioned, the potential material erosion problem caused by high velocity ions from the thrusters is a significant configuration consideration. The physical process for the erosion is known as sputtering. The expellant plasma beam, which is well collimated for propulsion efficiency, has a discernible fringe of primary velocity ions which extends over the entire hemisphere around the beam axis. Consequently, during orbit transfer operations, the electric propulsion thrust vector must be controlled or the satellite protected to prevent an erosion problem. An estimate of surface removal of silicon and graphite has been prepared via modeling of sputtering yields and the ion flux density profile of the propulsion plume.

Typical erosion characteristics are shown in Figure 6.2-3 for a case involving a thruster array consisting of 1000 thrusters and presenting an effective exposure time of 20% of the 180 day mission trip time. For example, with a beam angle of 20 degrees and a range between thruster and object of 200 m, an erosion depth of 1 mil may occur in a graphite or silicon component. Whereas this amount of erosion may be acceptable (no criterion exists) for primary structure, thin film coatings on solar cells and reflectors would be destroyed.

The total system impact of sputtering remains to be evaluated. The protection of thin film surfaces will require particular attention, but primary structure does not appear to present a problem. Elimination of the erosion condition is possible through use of gimbal limits (pointing restrictions) on thruster panel and/or placement of the thrusters at an acceptable distance from the satellite.

6.2.1.2.1.2 Subsystems

Electric Propulsion

Seven major system elements are used in the electric propulsion system as shown in Figure 6.2-4. These are the generation of power by the satellite, the distribution of the power to the electric thruster system, conditioning the power by power processing equipment, thrusters and propellant storage. Power processing is estimated at 95% to 96% efficiency, therefore necessitating a thermal control system. Finally, in order to get the required pointing of the thrusters, a gimbal system is required. Each of these systems has been characterized in terms of mass and cost characteristics and incorporated into a cost optimization model. Further discussion on each of these elements follows.

SYSTEM GEOMETRY

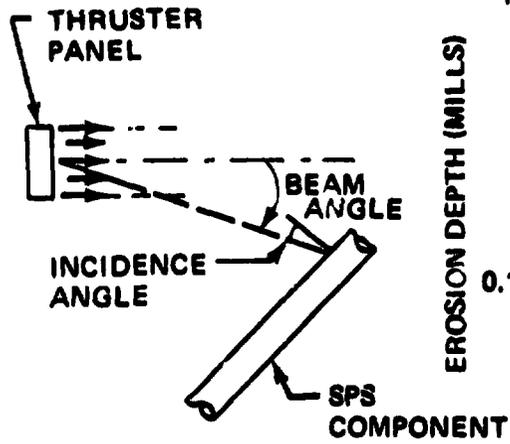

EROSION

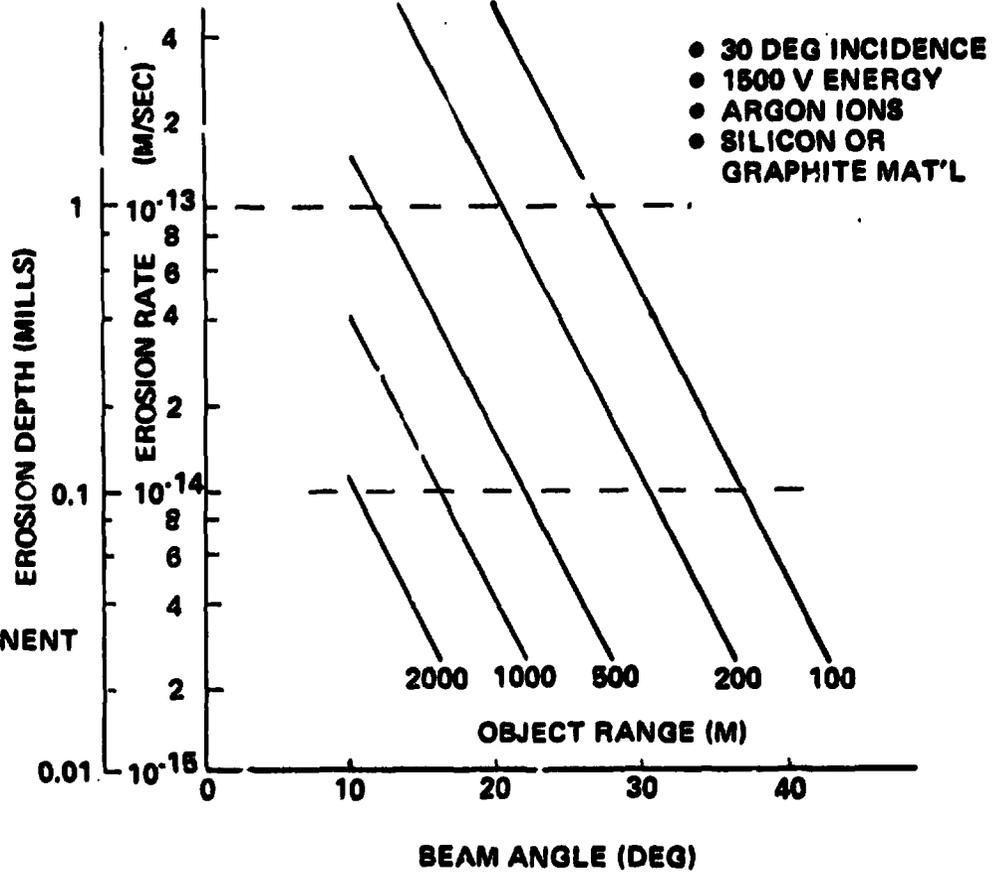

D180-20689-5

ORIGINAL PAGE IS
OF POOR QUALITY

Figure 6.2-3 Sputtering Erosion Rates

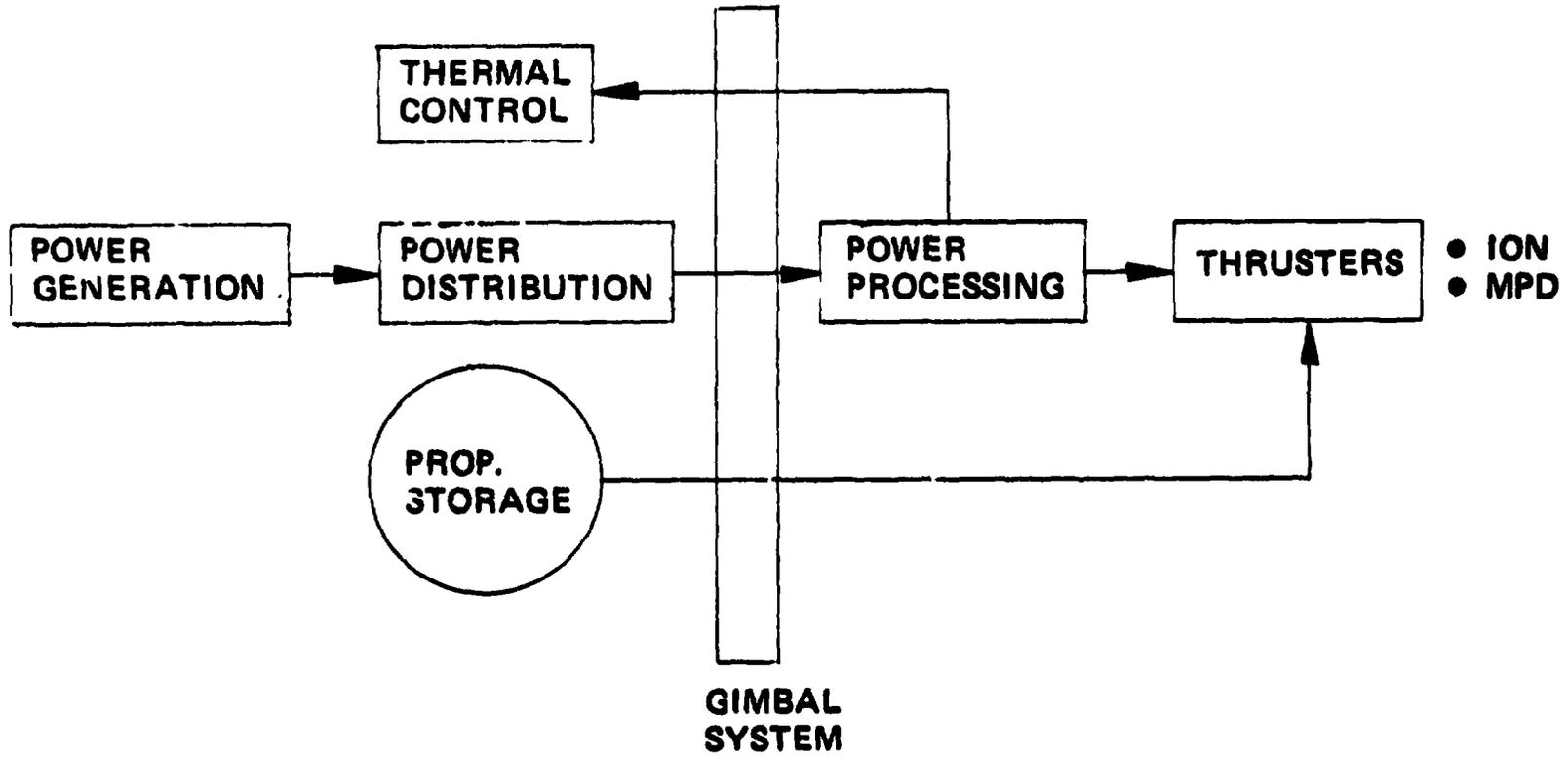

174

D180-20689-5

Figure 6.2-4 Electric Propulsion System Elements

Thrusters

The reference 120 cm ion thruster is illustrated in Figure 6.2-5 with design and selected operating characteristics (resulting from transportation optimization) shown in Table 6.2-1. Parametric performance predictions for this thruster are shown in Figure 6.2-6. The parametric data are based on extrapolations from current 30 cm mercury ion thruster technology, including the recent 4A (beam current) demonstration tests which showed that the double current density was feasible, but that thruster life would be reduced roughly 50%. This should be compatible with SPS transfer requirements and is the basis of the selection of a beam current of 80 amperes.

The system implications of each of these performance parameters is as follows: Beam voltage will have an impact on the I^2R losses and the amount of plasma losses involved in the power distribution system; efficiency influences the amount of power required for the operation; thrust level will establish the number of engines required; and finally, the input power will determine the amount of solar array which must be deployed for the transfer operation. These characteristics along with trip time options were incorporated into the optimization performance/cost model.

Table 6.2-1 Selected 1.2 M Argon Ion Thruster Characteristics

Fixed Characteristics		
Beam Current:	80.0	Amps.
Accel. Voltage:	500.0	V.
Discharge Voltage:	30.0	V. (Floating)
Coupling Voltage:	11.0	V.
Dbl. Ion Rates:	0.16	(J2/J1)
Neutral Efflux:	4.8384	Amp. Equiv.
Divergence:	0.98	
Discharge Loss:	187.3	ev/ion
Other Loss:	1758.0	W
Utilization:	0.892	
Life:	8000	hr.
*Weight:	50.	Kg.
Selected Characteristics		
Screen (Beam) Voltage:	600	V.
Input Power:	65	KW
Thrust:	2	N
Efficiency:	65%	

*Weight prediction courtesy of F. Masek of HRL.

Thruster Performance Analysis—Previous estimates of ion thruster performance were based on data prepared by Beyers of LeRC [1] where it was assumed that the performance of the 30-cm mercury ion thruster could be approximated by larger argon thrusters, and the data were evidently based on an assumed ionization loss of 200 ev/ion with utilization efficiency in the range of 0.8 to 0.9. Recent publications [2,3,4] however, report losses of 300 to 400 ev/ion and low utilization efficiency (0.6) for a 30-cm argon thruster. This is a fundamental trend which occurs because of the lower molecular weight of argon (39.948) relative to mercury (200.59) and its higher first ionization chamber temperature. This effects a proportional increase in the escape rate of neutrals, hence the trend to low utilization efficiency. Also, since 90 to 95% of newly formed ions are lost to collisions with the walls of the ionization chamber (leading to discharge losses which are many times the ionization energy of argon), the higher ionization energy of argon will tend to increase the net discharge loss.

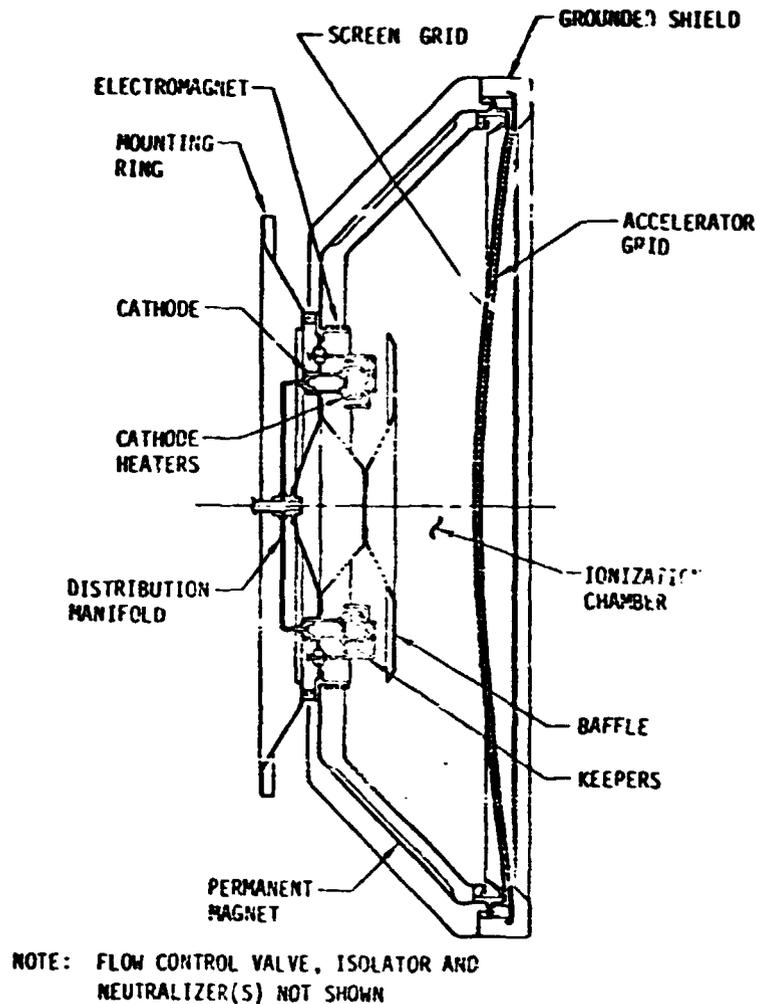

**ORIGINAL PAGE IS
OF POOR QUALITY**

Figure 6.2-5 120 CM Argon Ion Thruster

ORIGINAL PAGE IS
OF POOR QUALITY

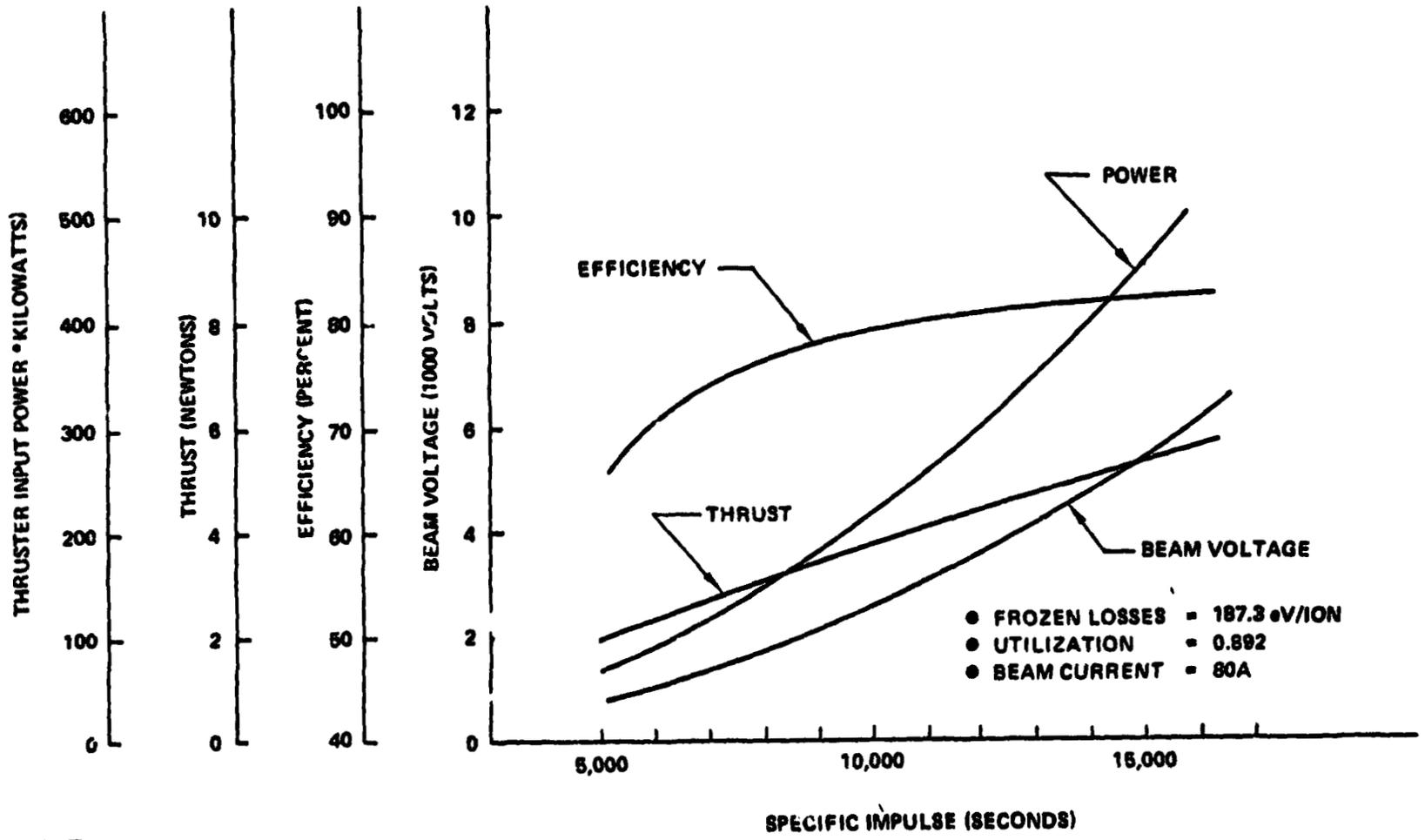

D180-20689-5

Figure 6.2-6 120-CM Argon Ion Thruster Performance

efficiency. Also, since 90 to 95% of newly formed ions are lost to collisions with the walls of the ionization chamber (leading to discharge losses which are many times the ionization energy of argon), the higher ionization energy of argon will tend to increase the net discharge loss.

Fortunately, these trends to lower performance can be countered by adopting the small hole accelerator grid (SHAG) optics concepts [5]. Test data show that SHAG optics reduce neutral efflux by 50% and also reduce double ion production (also 50%) by admitting a lower discharge voltage and reduced atomic density in the ionization chamber.

An additional counter to low performance trends associated with argon occurs because of geometry improvements. Since the probability of useful ion escape from the ionization chamber is proportional to the screen area divided by the chamber area, a larger thruster will result in reduced discharge losses if the chamber depth is increased less than the diameter. Kaufman [6] shows that the optimum chamber depth is, in fact, nearly independent of diameter.

The effects of a flatter geometry, SHAG optics, lower discharge voltage, higher ionization potential and higher thermal velocity have been mathematically combined to predict argon performance in a 120-cm thruster. This analysis predicts that the design improvements effectively balance the undesirable propellant characteristics.

Although the combination of higher double ionization potential (27.8 eV for argon vs 18.7 eV for mercury) and reduced discharge voltage (via SHAG optics) should reduce the double ion production rate, production data from 30-cm Hg testing was conservatively unchanged for this analysis. Lower double ion production rates imply that internal erosion due to sputtering will be lower and that thruster lifetime will increase correspondingly. Also, the SHAG optics prevent the increase in neutral efflux density which would otherwise be expected with argon. This means that the argon thruster optics should equal 30-cm Hg technology and, therefore, have lifetimes of 15,000 hours. These considerations lead to a lifetime prognosis of 8000 hr for the 120-cm thruster as being an easily achievable technology development requirement.

Test data on argon thrusters [7] show that the power processor can be simpler because the heater supplies required to prevent mercury condensation can be eliminated. Revised power supply requirements are given in Table 6.2-2. Thruster control can be by regulation of the discharge current. Propellant flow rate control can be via choked orifices in conjunction with an isolation valve for use in case of thruster failure.

It is concluded that large argon ion thrusters with SHAG optics can have performance characteristics about the same as the 30-cm mercury thruster. Furthermore, a life-time suitable for SPS missions should be achievable via existing technology.

Table 6.2-2: Power Processing Requirements (1)

Supply	Voltage (Volt)	Current (Amp)	Power (Watts)
Screen Grid (2)	Variable (3)	--	--
Discharge (4)	30.	499.5	14985.
Accel. Grid (2)	500.	0.1	50.
Cathode Keeper (4,6)	5.	20.0	100.
Neutralizer Keeper (4,6)	14.	52.0	728.
Coupling Bias	11.	80.	880.
Neutralizer Heater (5)	--	--	2000.

NOTES

- (1) Requirements are for each 80.0 Amp Thruster.
- (2) Must have current interruption capability for arc suppression.
- (3) See Figure 6.2-6.
- (4) Floating at screen supply voltage.
- (5) Required for start-up only.
- (6) 3000 v. start spike required.

Power Processing Concept

SEPS type power processing would be much too complex and expensive for a propulsion which consists of thousands of high power ion thrusters, consequently a simplified concept has been postulated for SPS self power application.

The power processing approach assumes standard thruster subarrays containing 80 thrusters. Regardless of the number of sub-panels required the power processing approach will be generally the same. A sub-panel of 80 thrusters was considered as the reference case, since use of 120 cm thrusters results in a ready-to-install panel with a size of 12 m x 12 m which is the largest that can fit within the payload shroud of the two stage launch vehicle (in a flat stacking arrangement--12m x 23m if stacked on edge). A schematic of the propulsion module power processing concept is given in Figure 6.2-7 for a thruster panel having 2000 thrusters. Panels with fewer thrusters would have fewer PPU's (80 thrusters per PPU).

**ORIGINAL PAGE IS
OF POOR QUALITY**

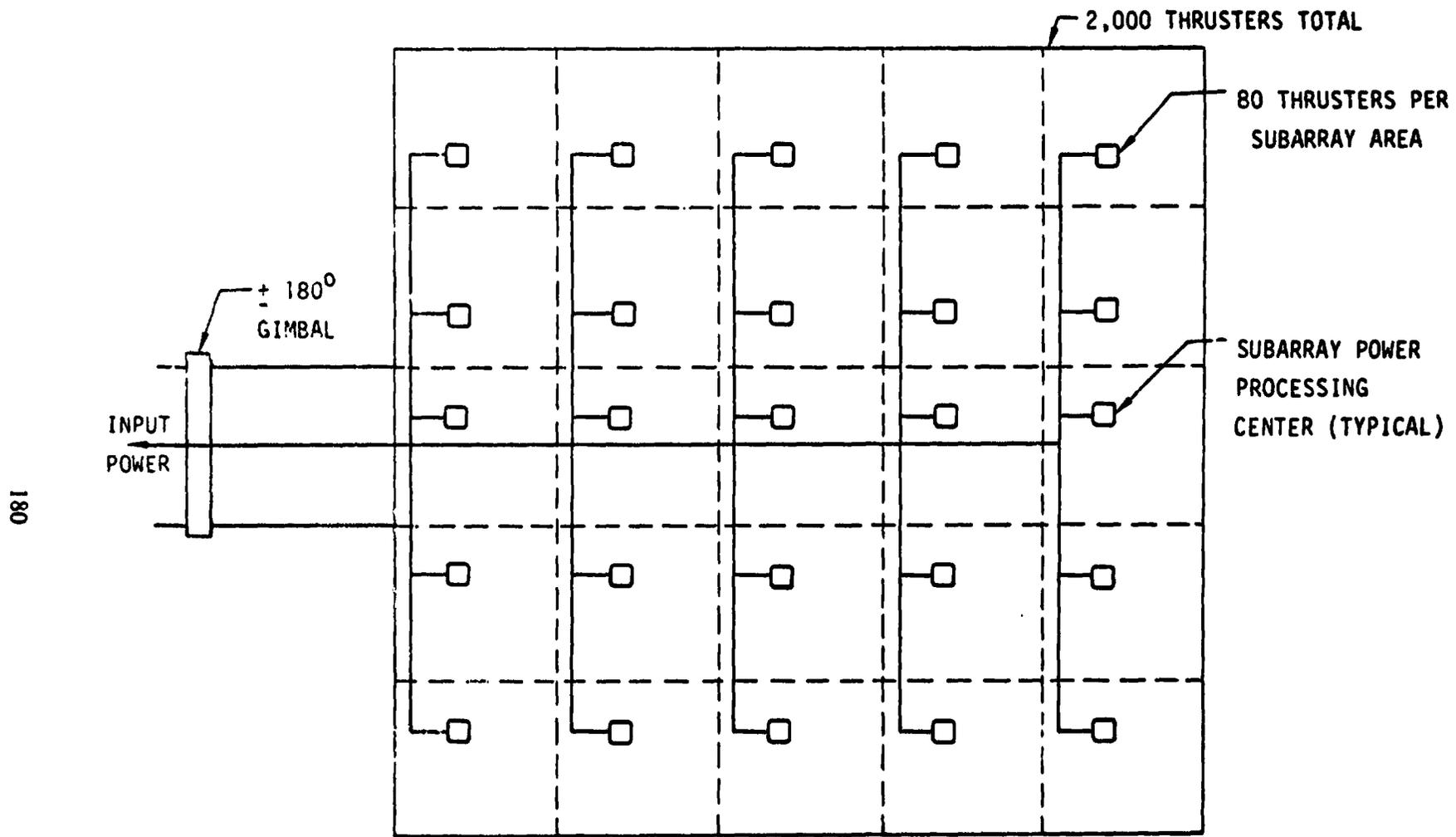

D180-20689-5

Figure 6.2-7 Propulsion Module Build-Up

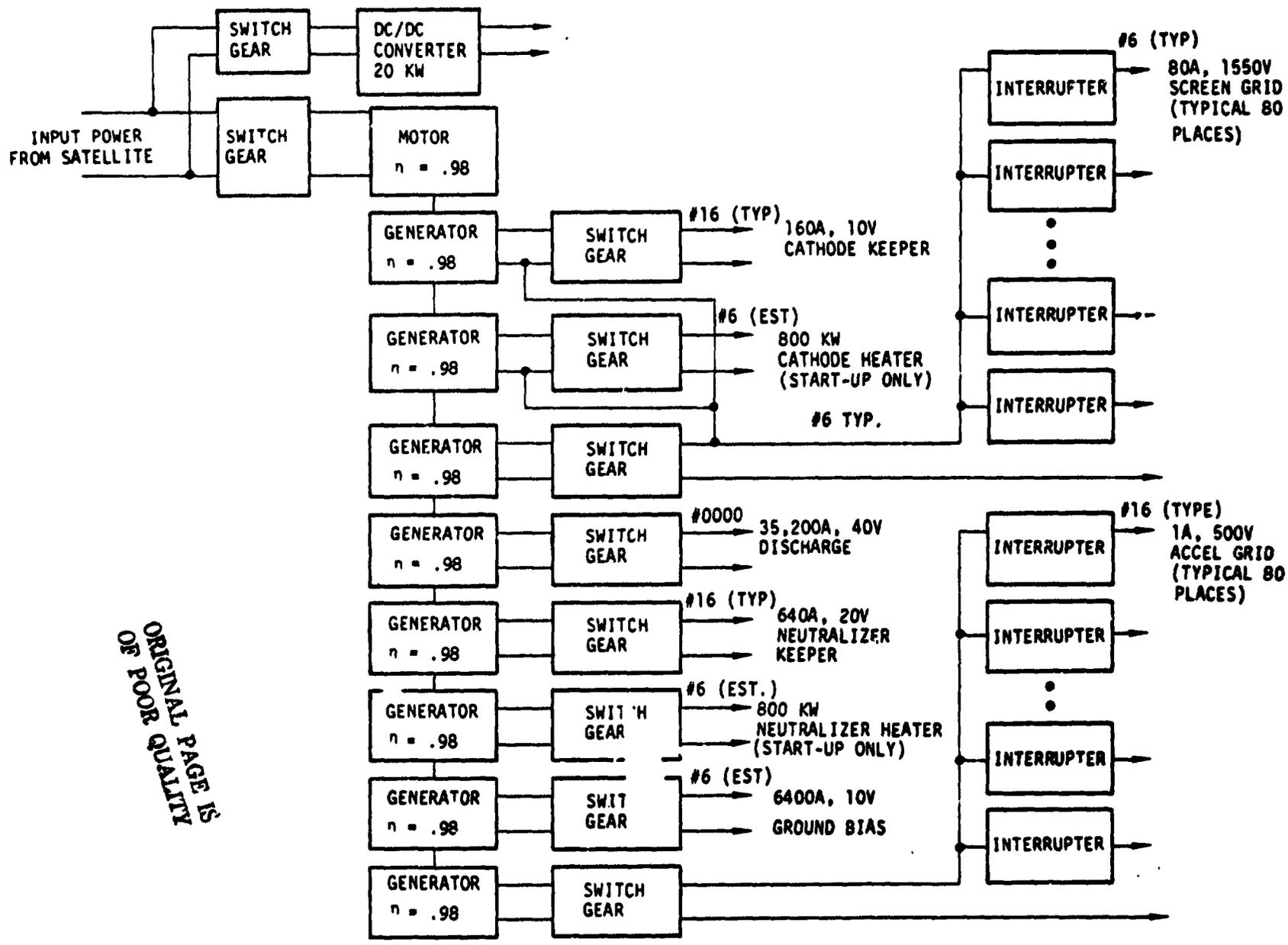
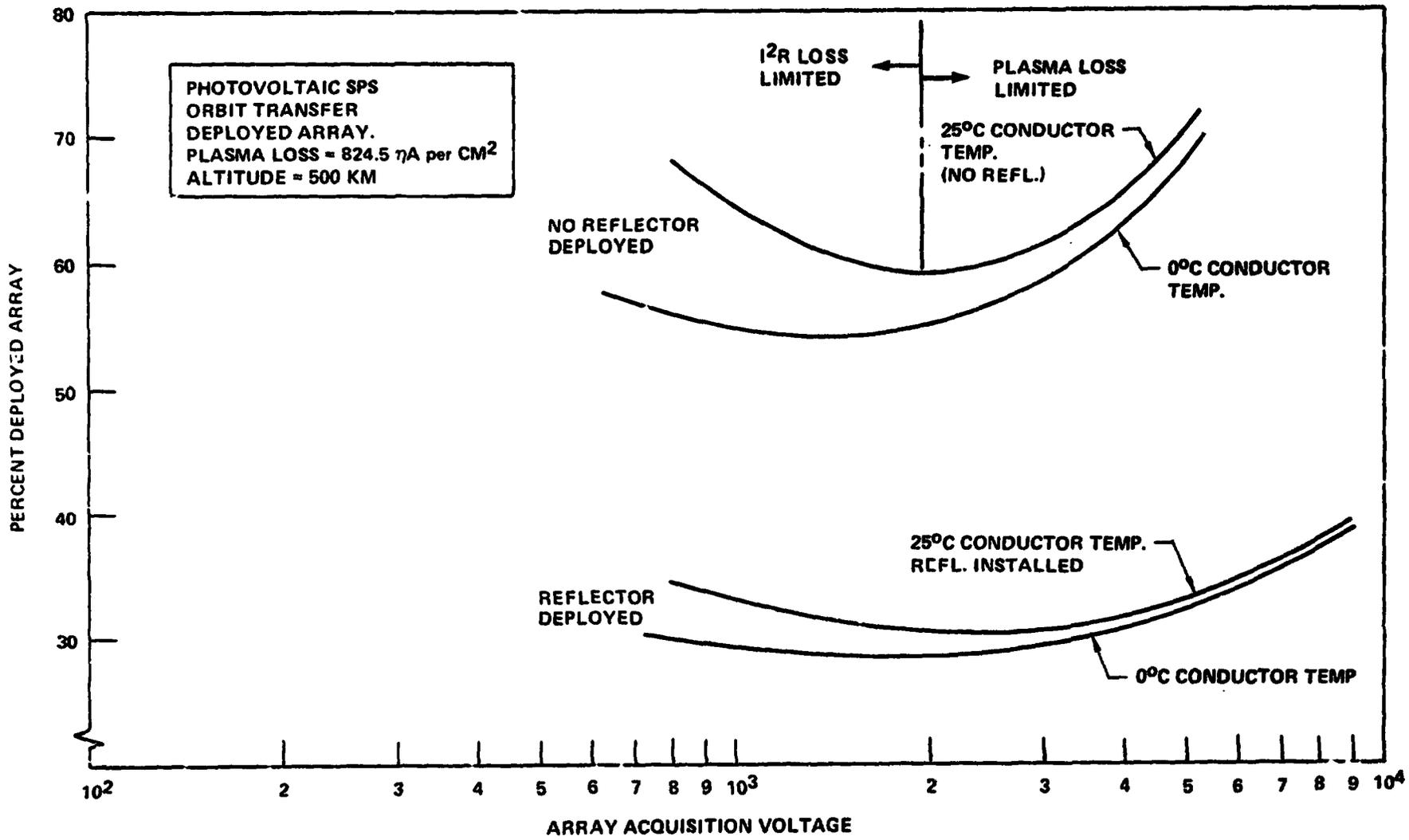

Figure 6.2-8: Propulsion Subarray Power Processing

182

ORIGINAL PAGE IS
OF POOR QUALITY

D180-20689-5



185

ORIGINAL PAGE IS
OF POOR QUALITY

D180-20689-5

Figure 6.2-9: Orbit Transfer Solar Array Characteristics

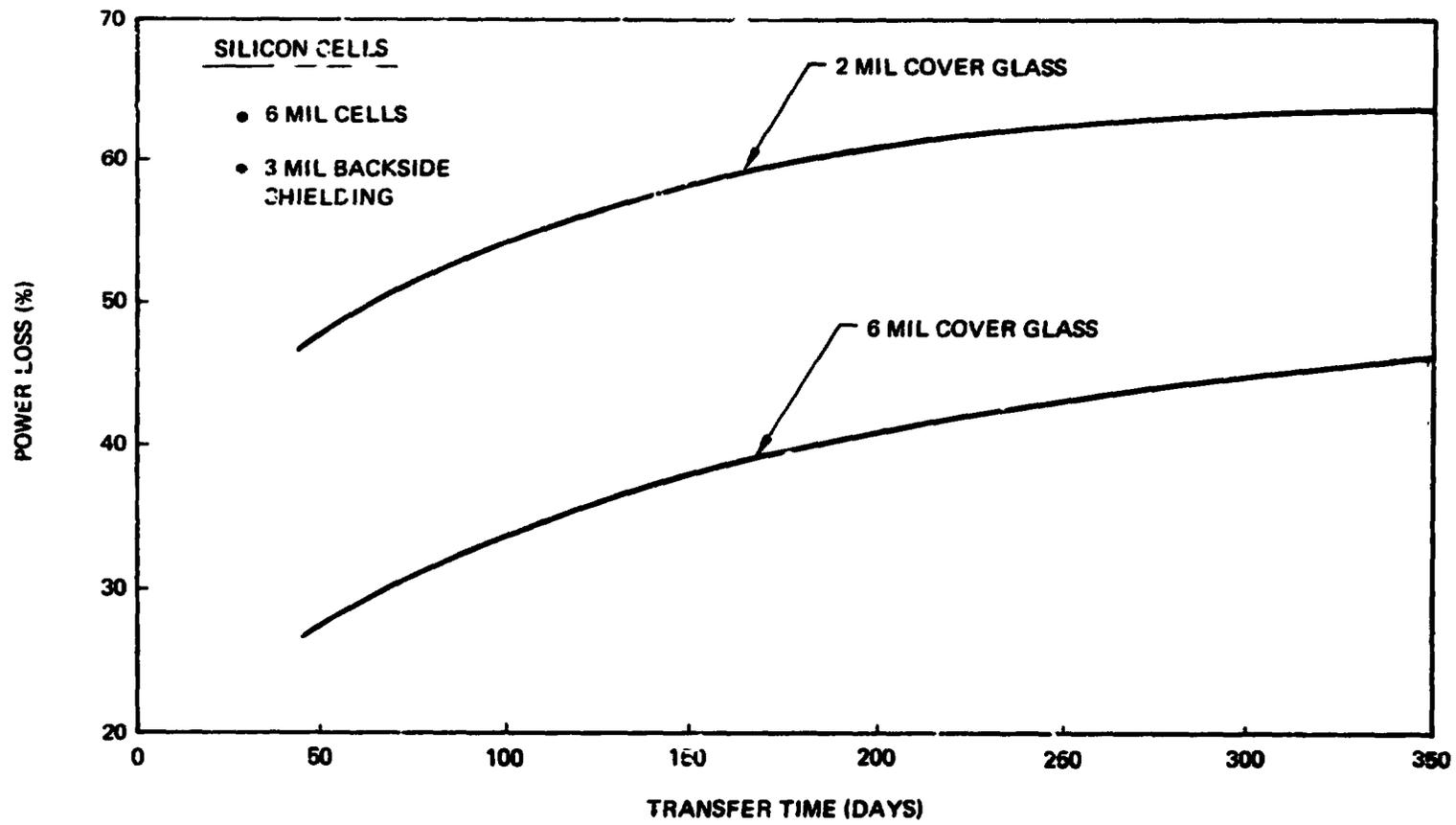

Figure 6.2-10 Orbit Transfer Radiation Degradation Photovoltaic Satellite

C-3

187

ORIGINAL PAGE IS
OF POOR QUALITY

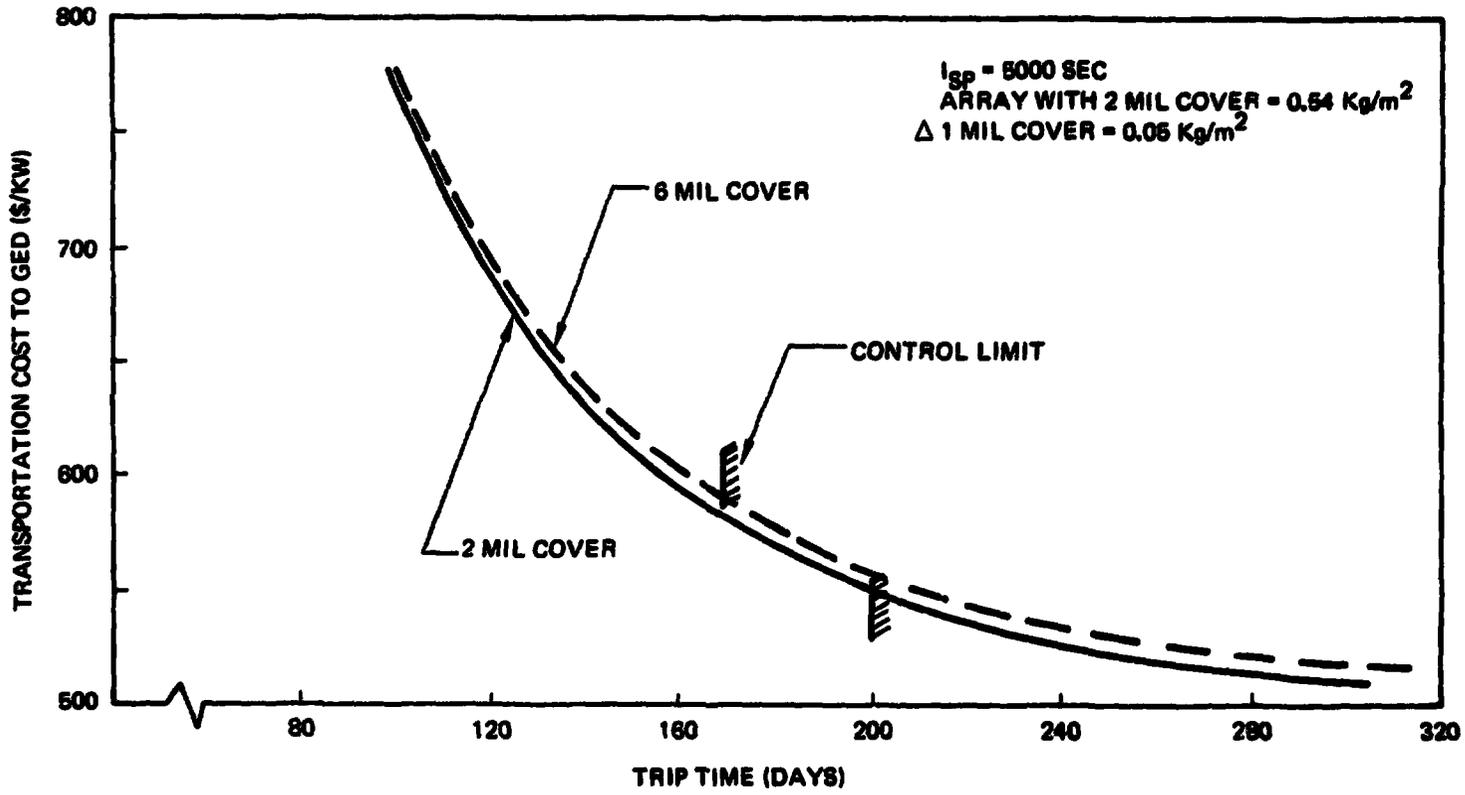

Figure 6.2 - 11 Photovoltaic Cover Glass Impact

D180-20689-5

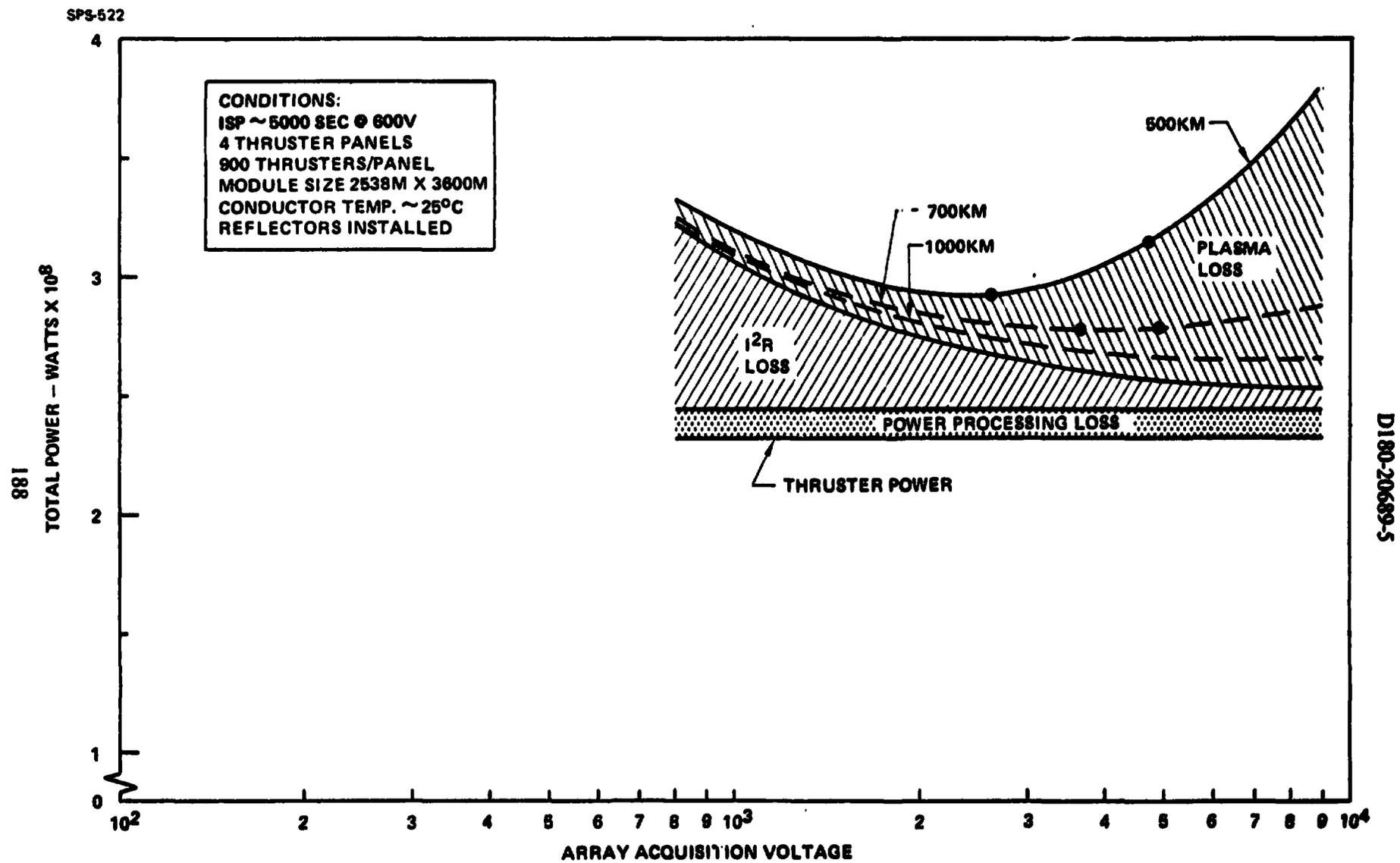

Figure 6.2-12: Orbit Transfer Power Requirements

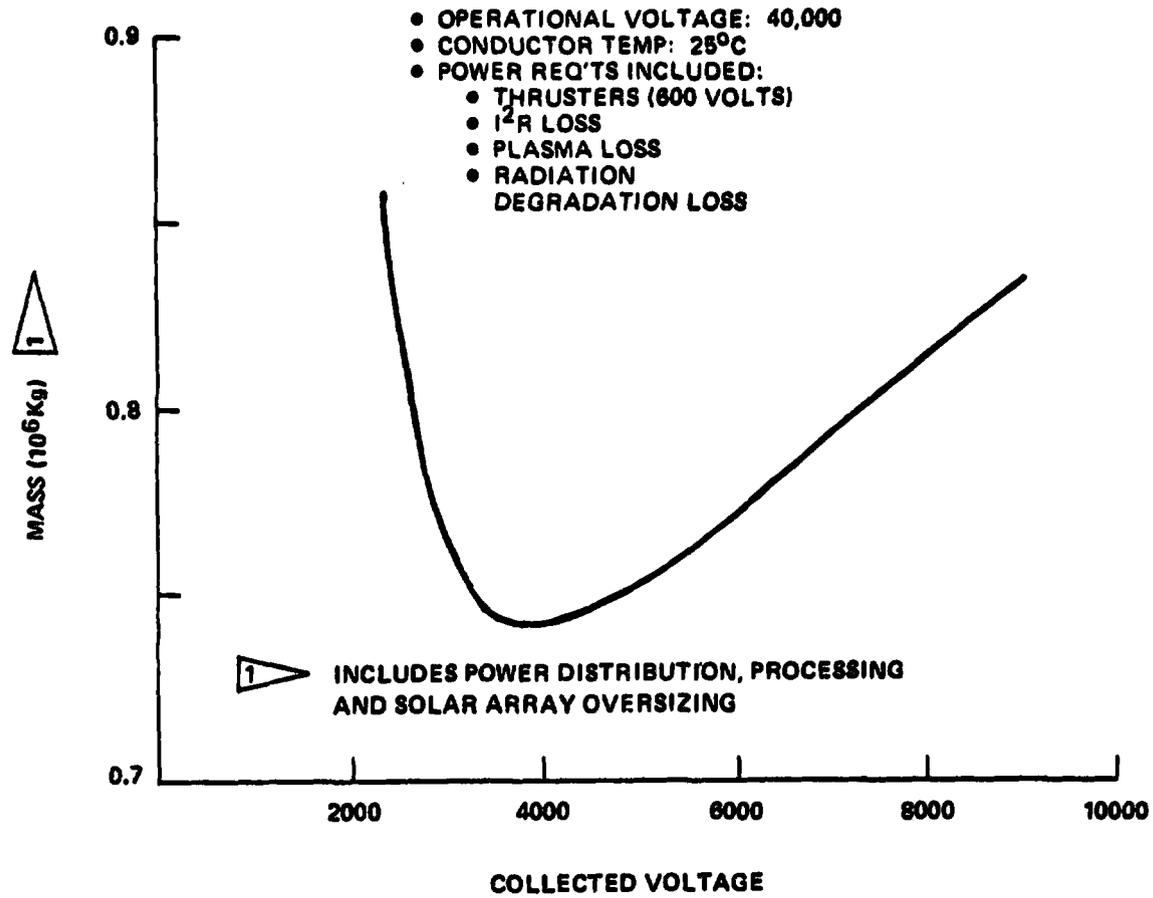
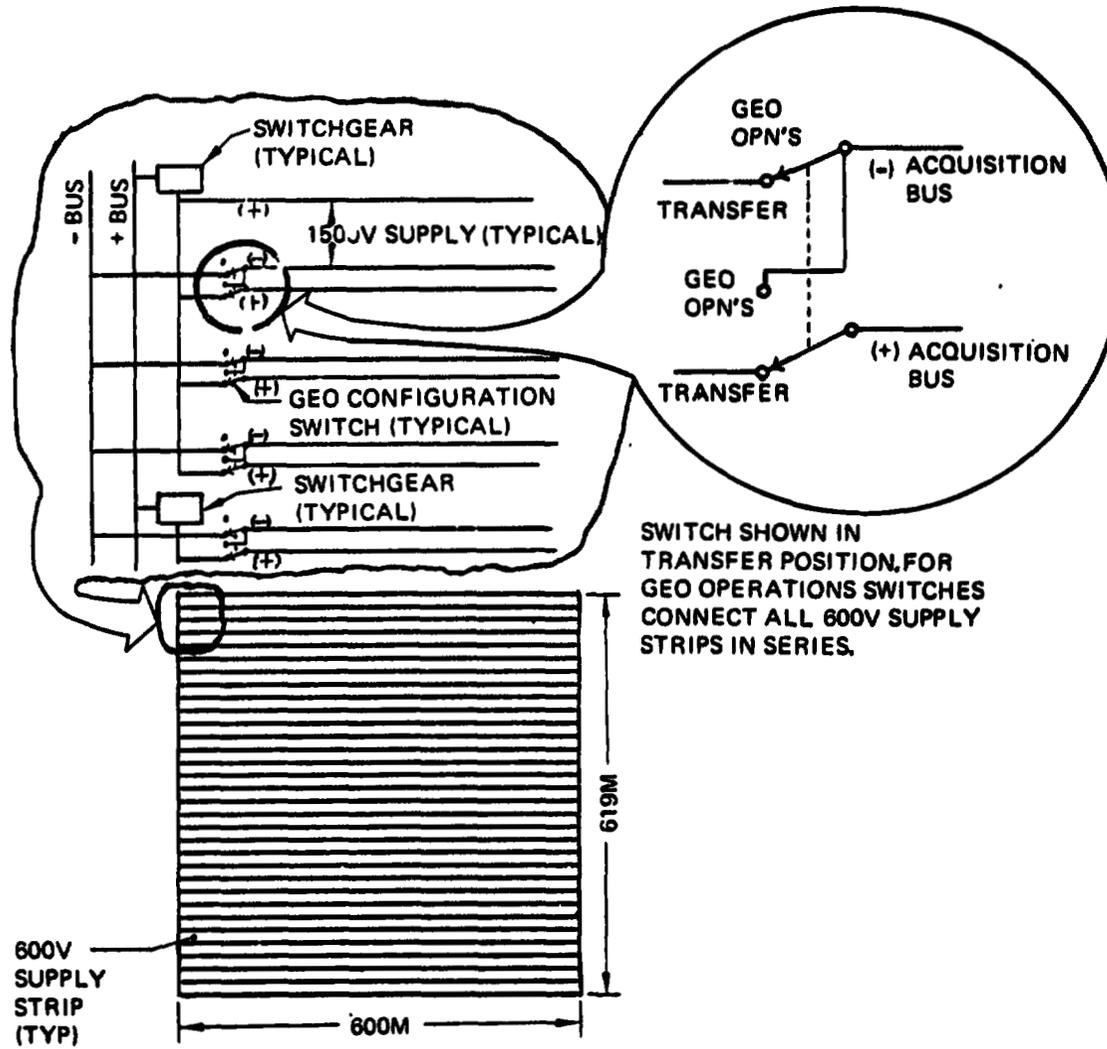

Figure 6.2-13 Orbit Transfer Voltage Selection
Silicon Photovoltaic Satellite

ORIGINAL PAGE IS
OF POOR QUALITY



D180-20689-5

Figure 6.2-14: Power Bay Configuration For Orbit Transfer

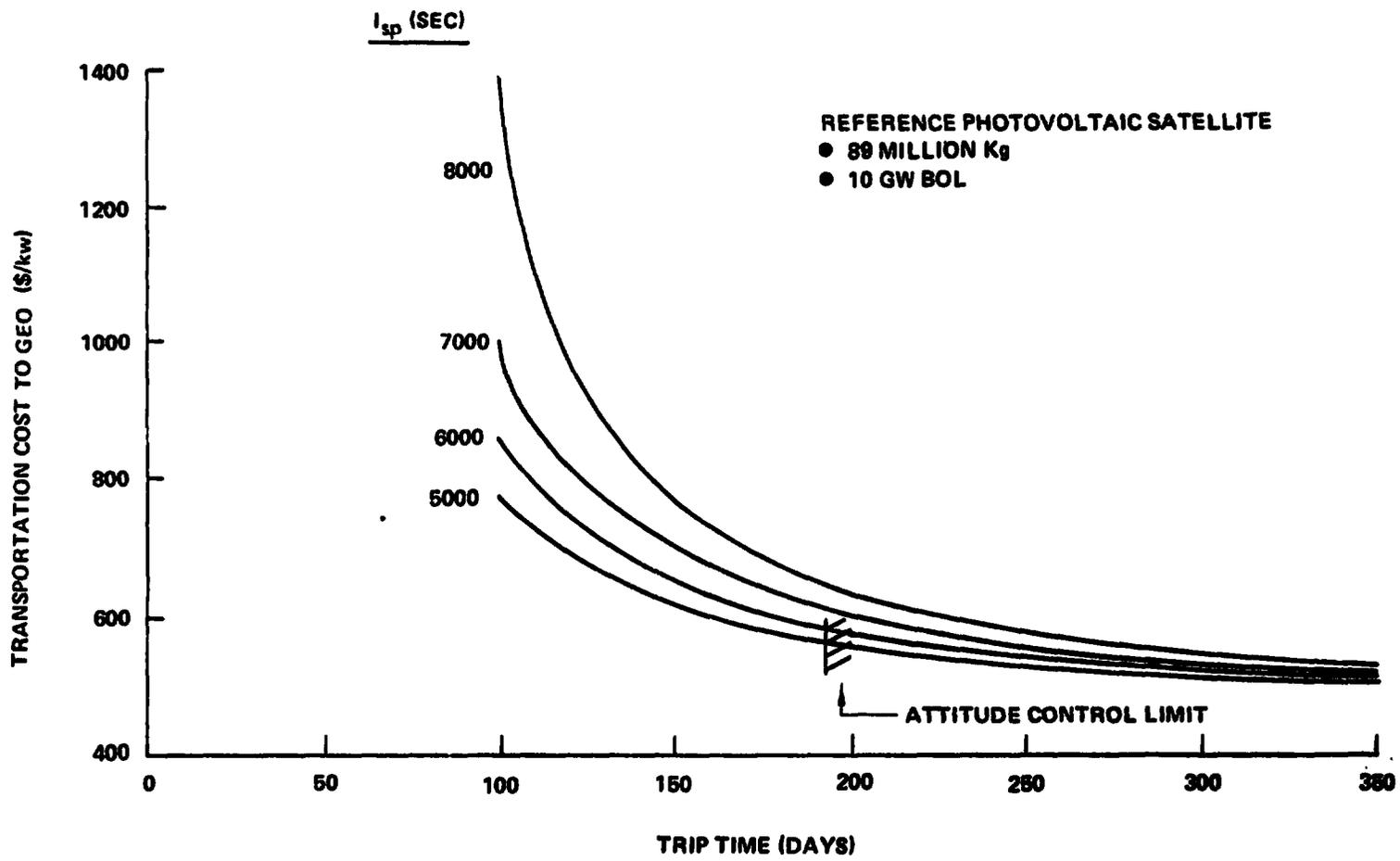

Figure 6.2-15 I_{sp} and Trip Time Optimization

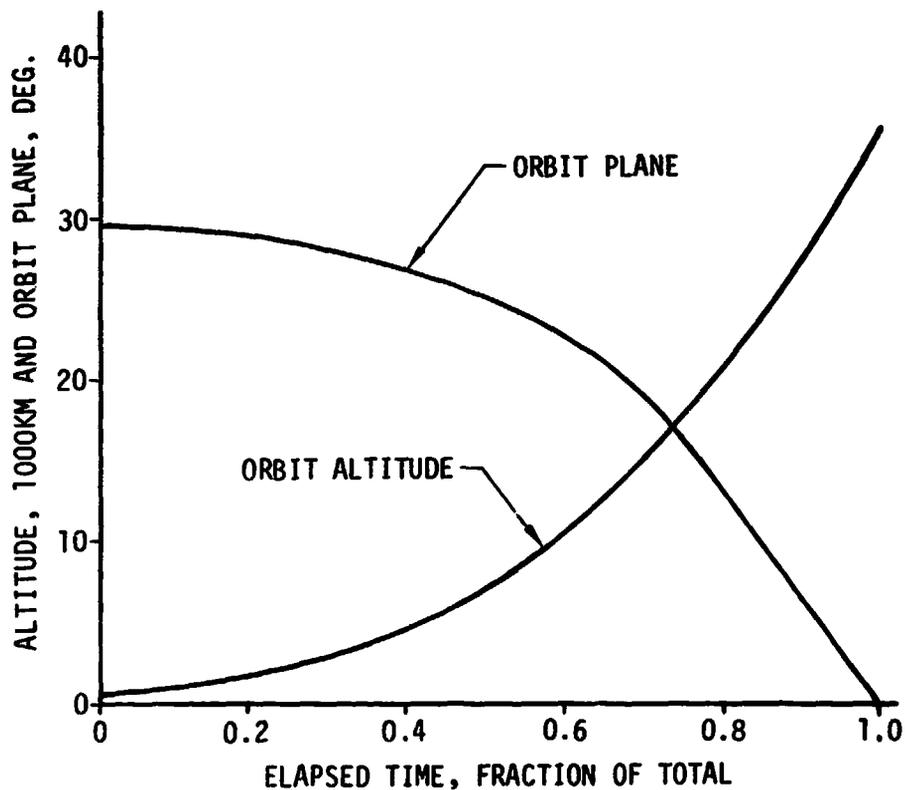
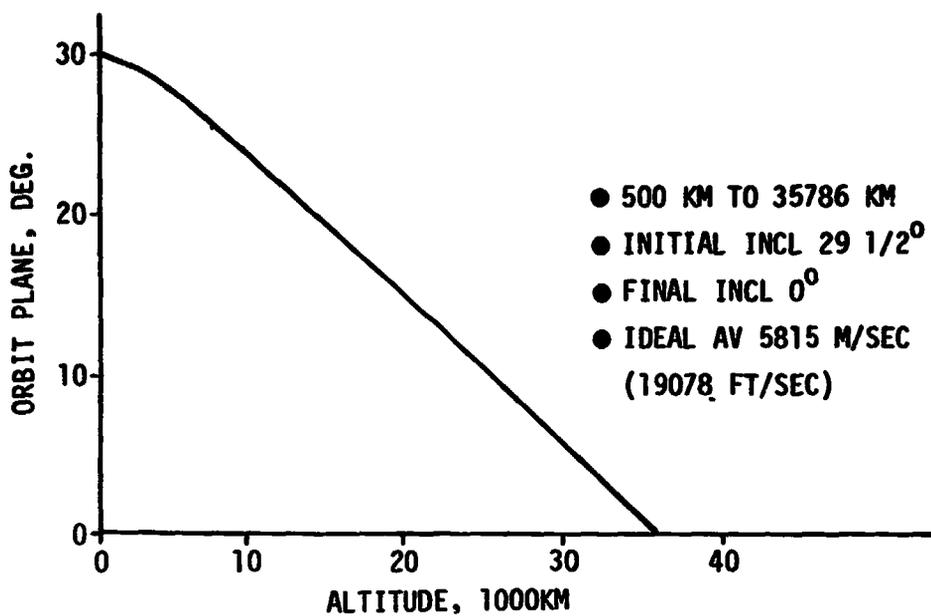

Figure 6.2-16 Low-Thrust Orbit Transfer Characteristics

SPS-660

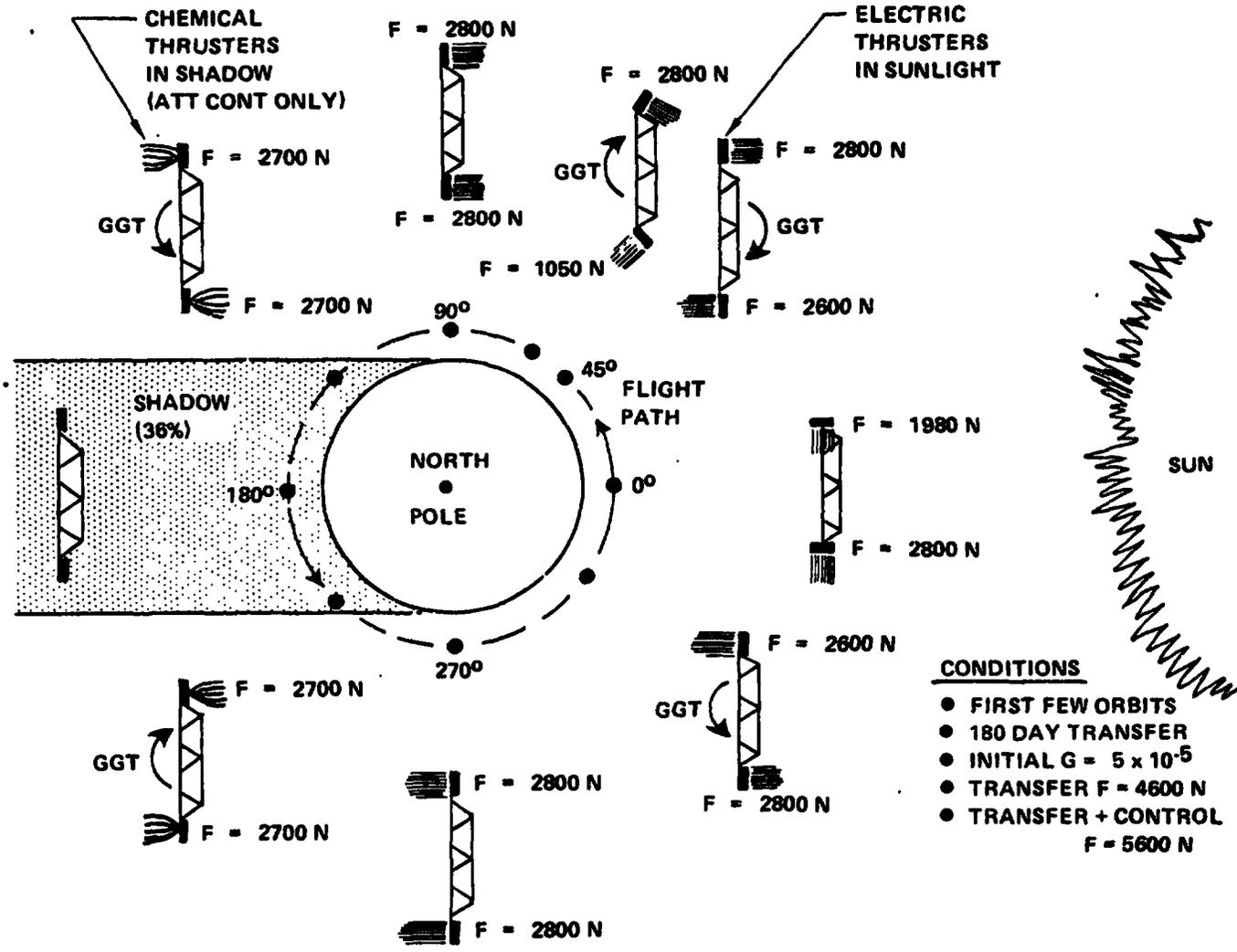
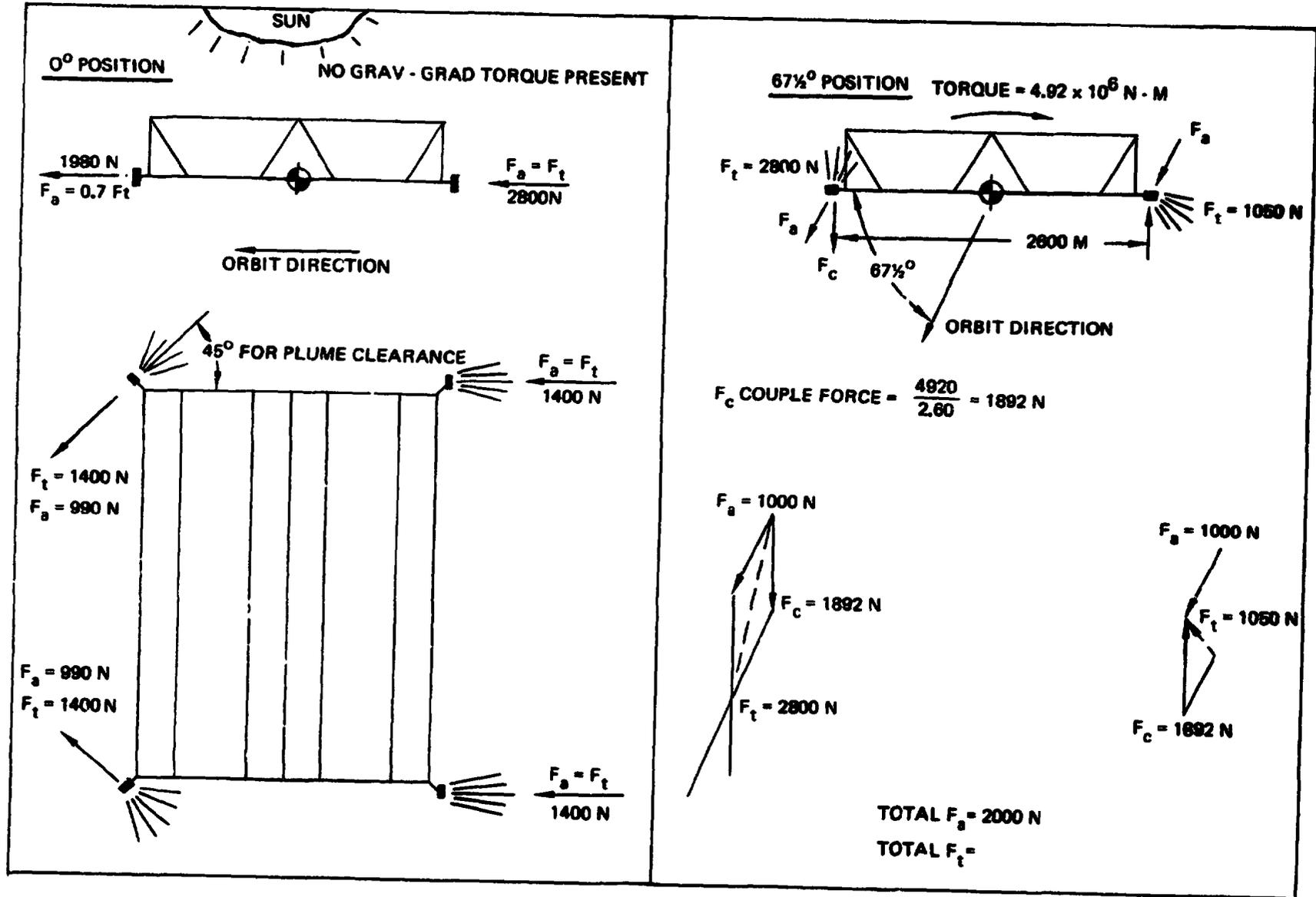

Figure 6.2-19 Orbit Transfer Thruster Utilization Photovoltaic Satellite

ORIGINAL PAGE IS
OF POOR QUALITY

199



D180-20689-5

Figure 6.2-21 Thrust Vector Analysis
 1/16 Photovoltaic Sat (CR = 2.0)

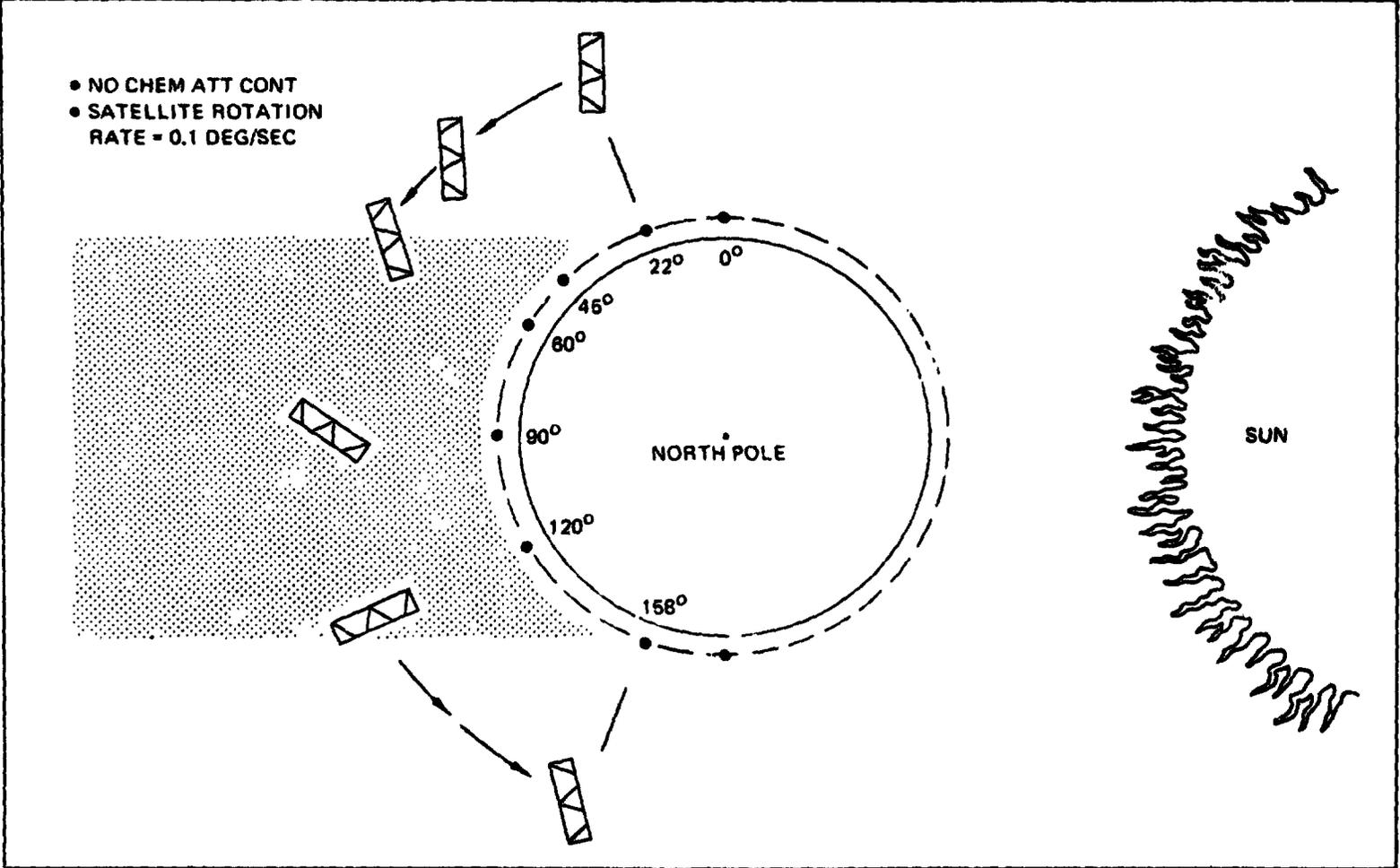
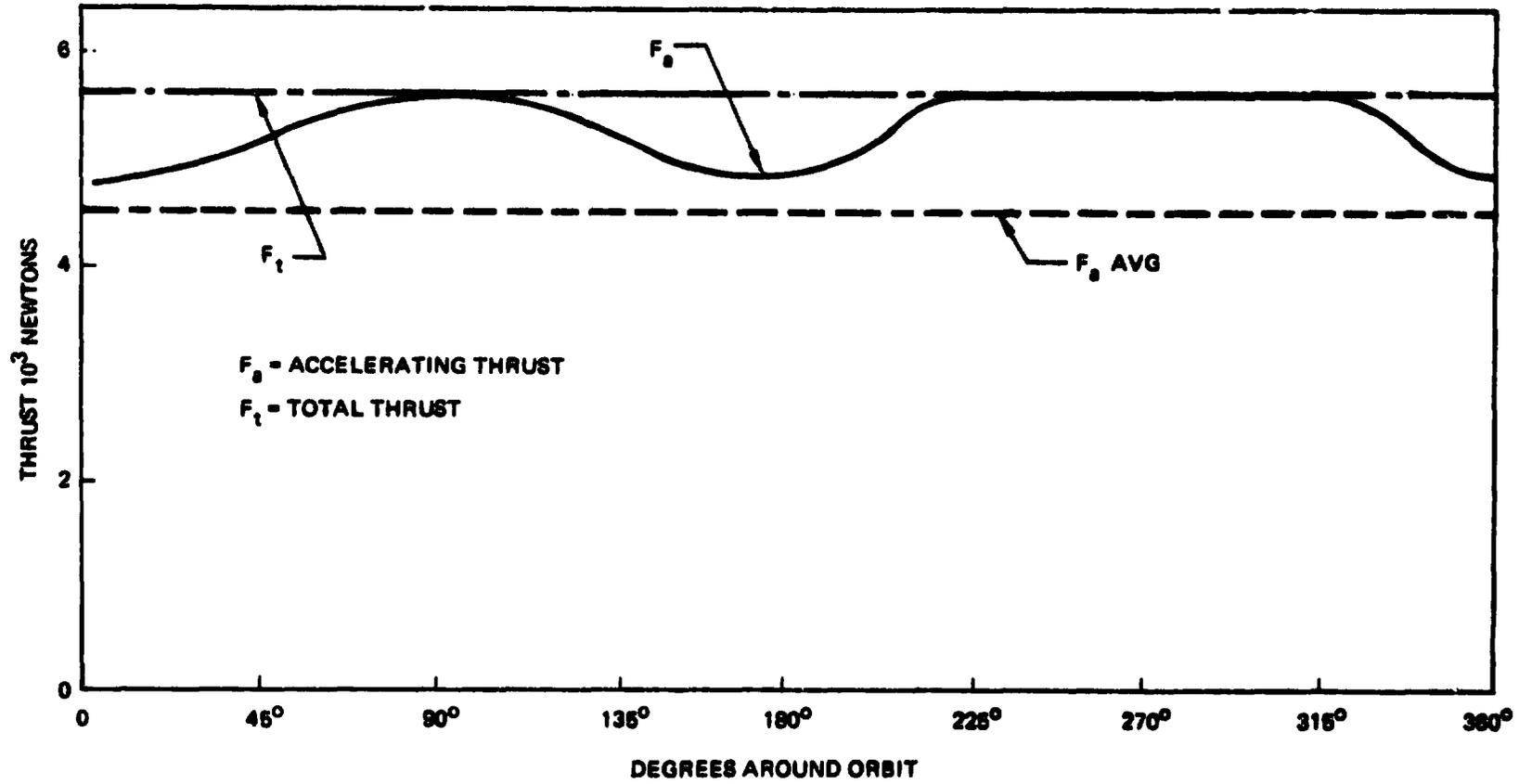

Figure 6.2 - 22 Uncontrolled Photovoltaic Satellite Module (In Shadow)

D180-20689-5



D180-20689-5

Figure 6.2-24 Thrust Profile Near GEO
1/16 Photovoltaic Satellite Module

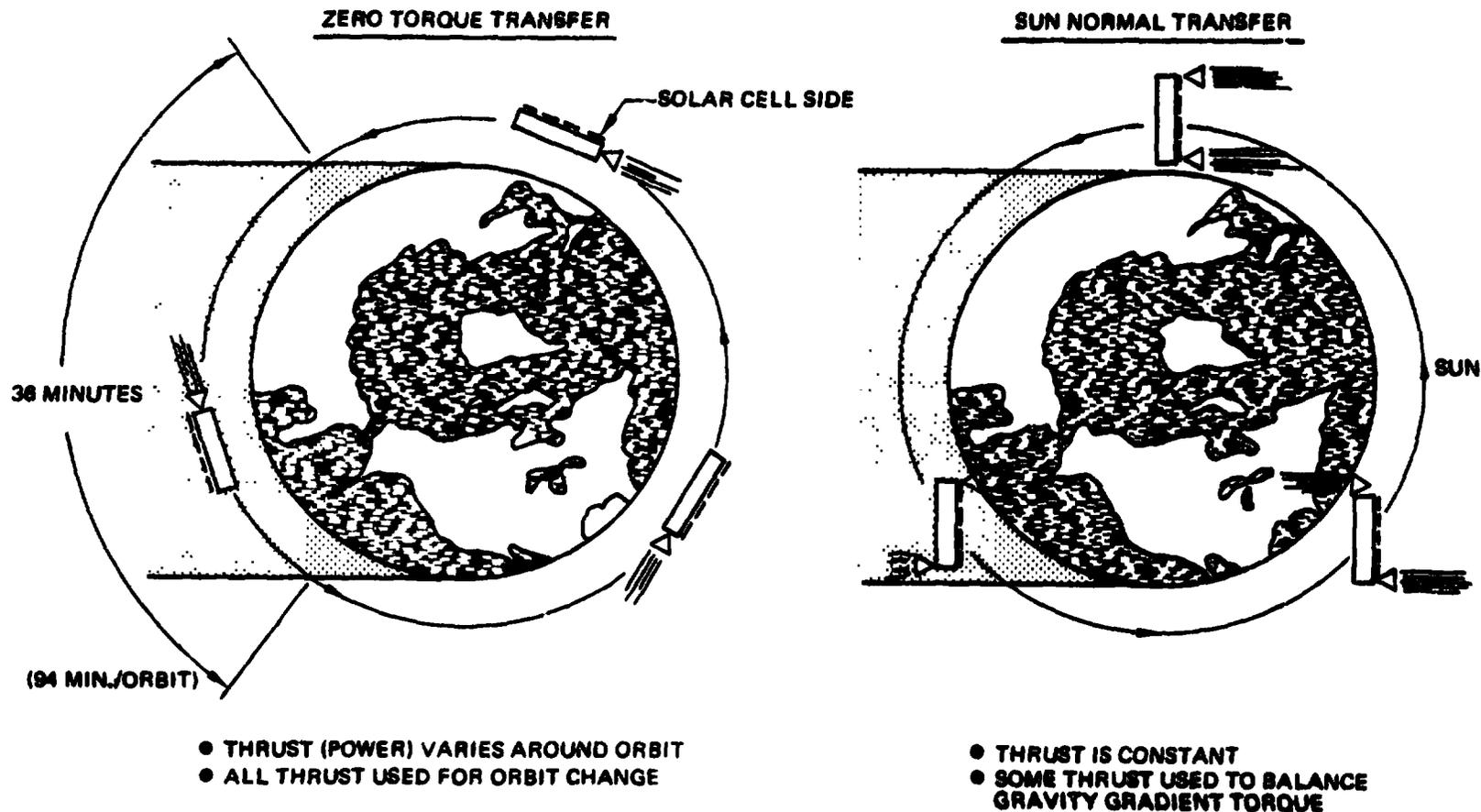

D180-20689-5

Figure 6.2 - 25 Alternate Transfer Attitudes

D180-20689-5

reference photovoltaic satellite. This situation is brought about because the higher power requirement for both conditions can be obtained without significant oversizing, because the thermal engine SPS is less sensitive to radiation degradation. (Similar results were obtained for annealable photovoltaics.) The selected Isp is 7000 seconds and the trip time is 160 days.

Thrust levels required to provide attitude control probably can be obtained with trip times as long as 250 days due to the lower satellite inertias. Therefore, with the optimum trip time of 160 days a wide margin of thrust exist for attitude control.

6.2.1.2.3.4 Mass Summary

Mass characteristics associated with the optimum self power orbit transfer system are presented in Table 6.2-11. The self power mass associated with the transfer of each of 16 satellite modules is 2.274 million kg.

**Table 6.2-11 Thermal Engine Self Power Mass Summary
(Per Module)**

<u>ITEM</u>	<u>MASS (10^6 kg)</u>
OTS Hardware	(0.593)
Thrusters	0.125
PPU	0.268
Tankage	0.022
Structure	0.072
Radiator	0.106
Chem Thrusters	NIL
Usable Propellants	(1.578)
Argon	1.281
LO ₂ /LH ₂	0.297
Satellite Modifications	(0.103)
Oversizing	0.025
Power Distribution	0.008
Struct (for Modularity)	0.07

6.2.1.2.3.5 Mission Profile and Flight Operations

Mission profile characteristics will be the same as for the reference photovoltaic satellite for the same trip time.

D180-20689-5

The reference flight control attitude is that of flying with the solar collectors always directed to the sun (same as for the photovoltaic satellite). Thruster utilization in terms of panels utilized, thrust level and approximate pointing angle is illustrated in Figure 6.2-32 for the first few revolutions of the transfer. Maximum thrust of a given panel is 2,000 newtons. Chemical thrusters are again used during the shadow periods of the orbit. However, in this case the thrust is considerably less than indicated for the photovoltaic satellite module due to the less satellite inertia. Without control during the shadow periods, the centerline of the concentrator would be approximately 20° off sun LOS.

Total thrust applied compared to that available for transfer acceleration is presented in Figure 6.2-33. Maximum thrust level per panel is 2000 N and relates to the cost optimum trip time of 160 days. The relatively close match-up between total thrust and thrust available is due to the much lower inertia characteristics as compared with the photovoltaic. The analysis used to establish the thrust level and pointing vector for several orbit positions is shown in Figure 6.2-34. Thrust profile for a satellite module as it nears GEO is shown in Figure 6.2-35.

6.2.1.2.3.6 Cost Analysis

DDTE and TFU cost for the self power components associated with the thermal engine satellite were not defined. Cost per flight assumptions are the same as specified for the reference photovoltaic satellite.

The total self power cost for each of the 16 modules is estimated at \$33 million with a transfer time of 160 days and Isp of 7000 seconds. No recovery and reuse of components is assumed.

Cost for the major elements associated with the self power are presented in Table 6.2-12.

Table 6.2-12 Self Power Cost for Thermal Engine Satellite
(Cost in Millions)

	<u>Satellite</u>	<u>Per Module</u>
OTS	(439)	(27.2)
Electric Thrusters	90	5.6
PPU	214.	13.3
Tankage	34.	2.1
Structure	11	0.7
Radiators	85	5.3
Propellant	4	NIL
Chem Thrusters	1.	NIL
Satellite Modifications	(91)	(5.7)
Oversizing	20	1.3
Power Distribution	71	4.4

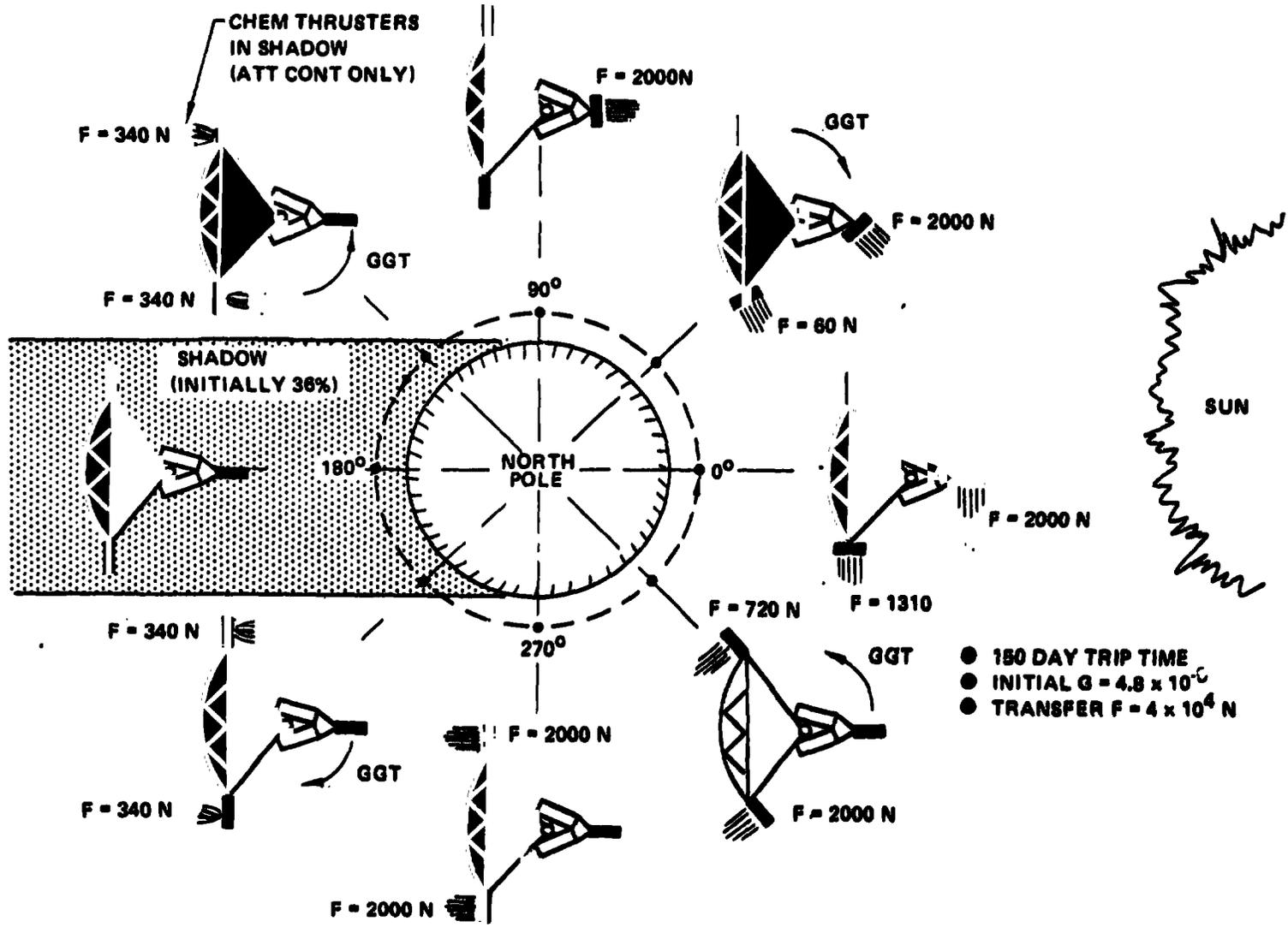

**Figure 6.2-33 Thrust Profile Near LEO
Thermal Engine Satellite Module**

D180-20689-5

ORIGINAL PAGE IS
OF POOR QUALITY

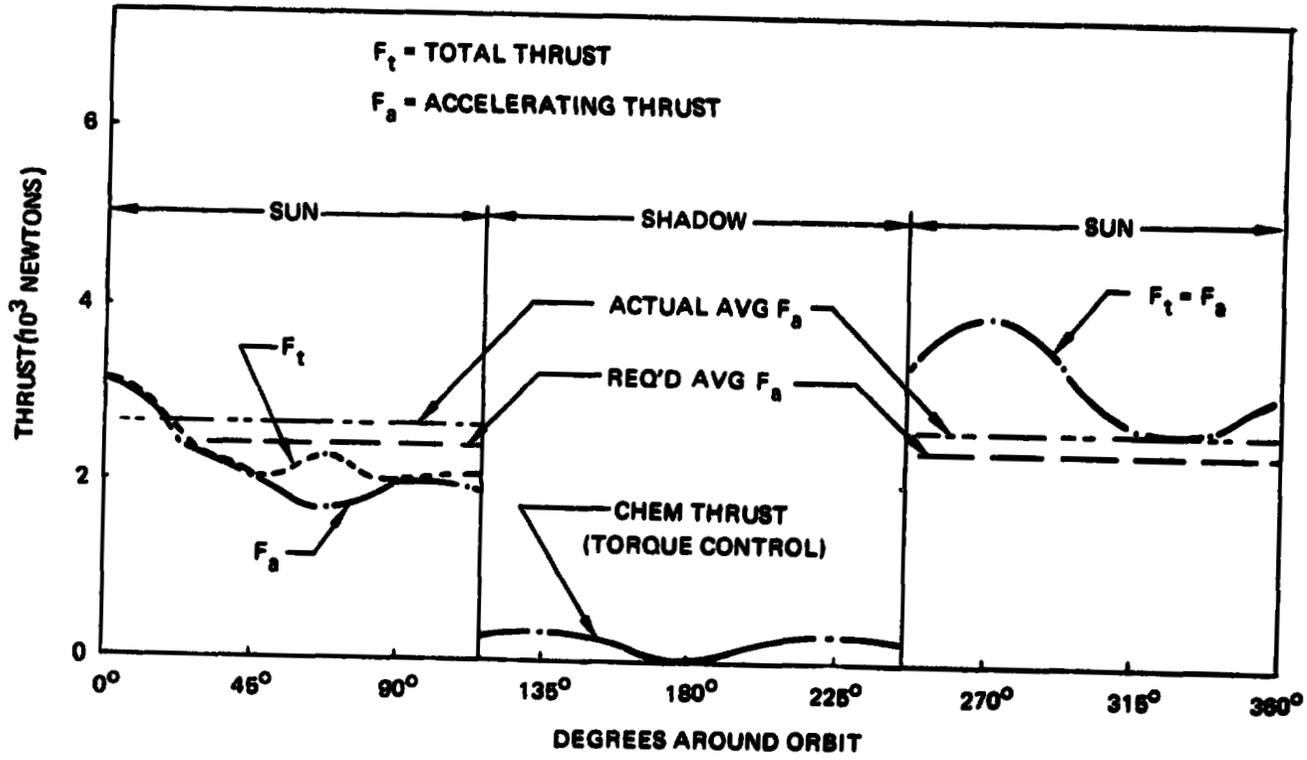
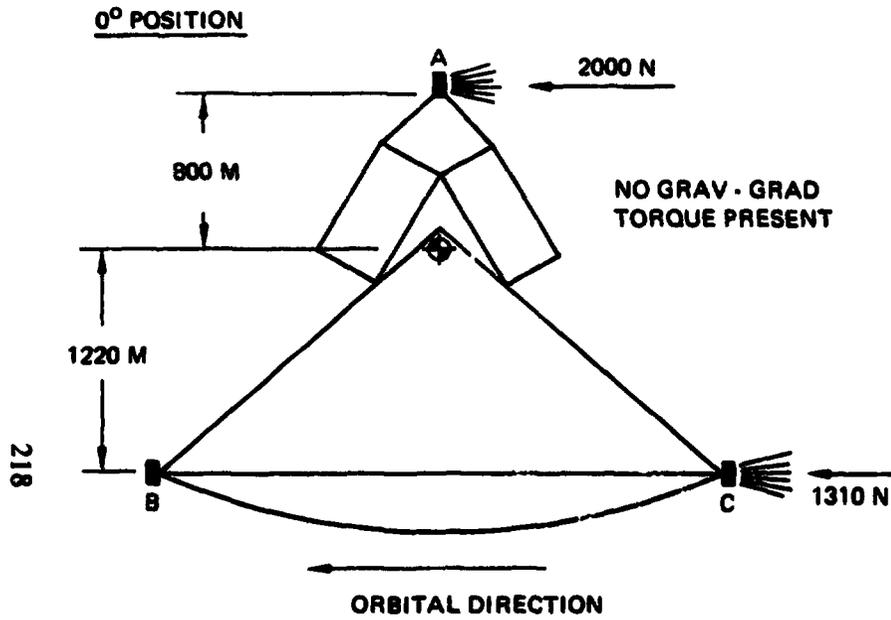

Figure 6.2-32 Orbit Transfer Thruster Utilization
Thermal Engine Satellite



MAX THRUST AVAILABLE AT A, B, OR C, = 2000 N
 APPLY 2000 N AT "A"
 $2000 \times 800 = 1.6 \times 10^6 \text{ N} \cdot \text{M}$

BALANCE BY FORCE AT C

$$C = \frac{1.6 \times 10^6}{1220} = 1310 \text{ N}$$

TOTAL $F_g = 2000 + 1310 = 3310 \text{ N}$

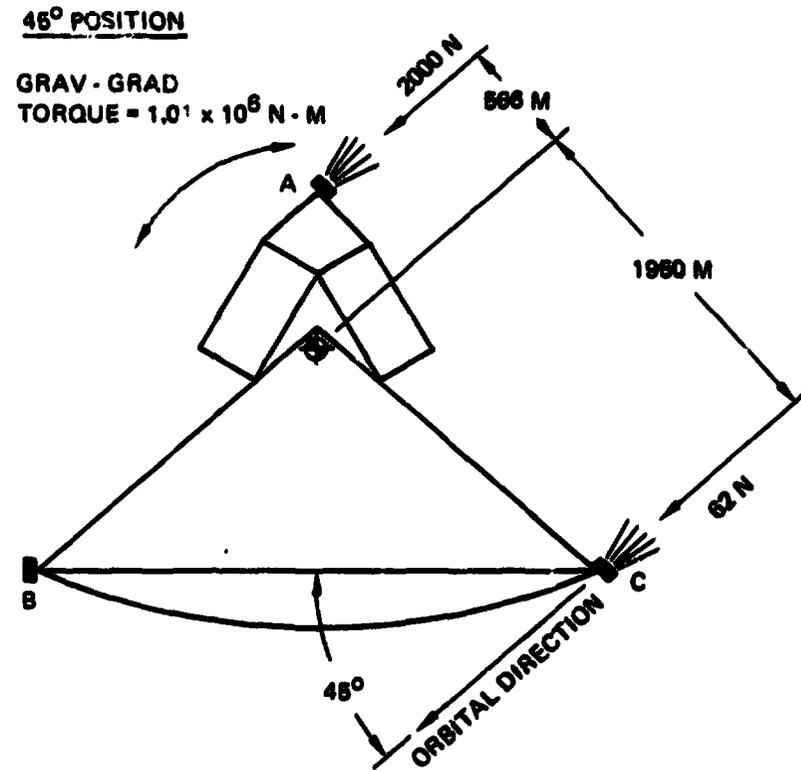

APPLY 2000 N AT "A"
 TORQUE = $2000 \times 566 = 1.13 \times 10^6$
 BAL TORQUE REQ'D = $1.13 - 1.01 = 0.12 \times 10^6$

$$\text{FORCE AT C} = \frac{0.12 \times 10^6}{1960} = 62 \text{ N}$$

TOTAL $F_g = 2000 + 62 = 2062 \text{ N}$

D180-20689-5

Figure 6.2 - 34 Thrust Vector Analysis
 Thermal Engine Satellite Module

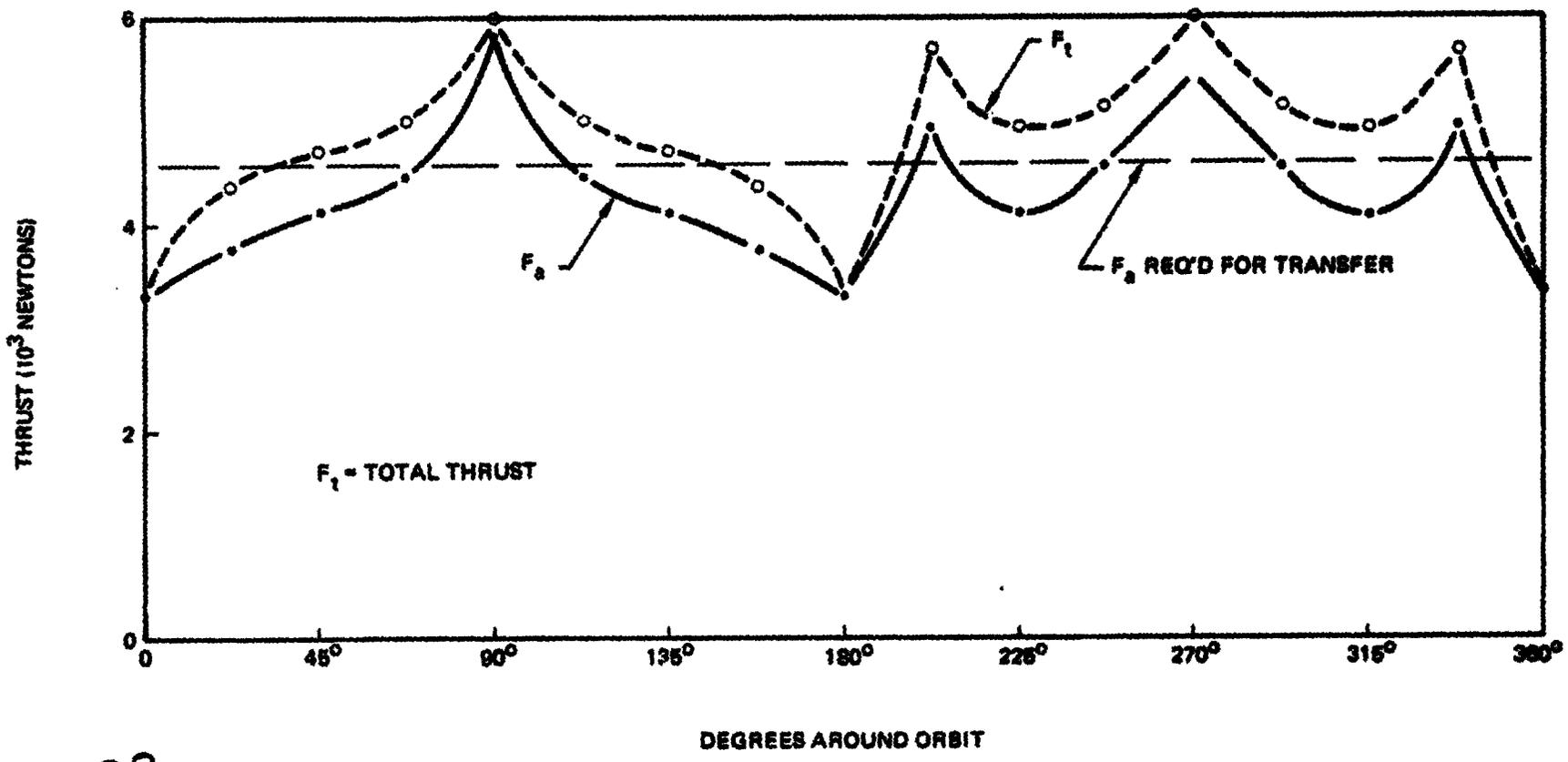

Figure 6.2-35 Thrust Profile Near GEO Thermal Engine Satellite

ORIGINAL PAGE IS
OF POOR QUALITY

6.2.2 Crew Rotation/Resupply OTV

The requirements associated with LEO construction crew rotation/resupply are different from those of the GEO construction option primarily as a result of the difference in distribution of the personnel rather than the quantity; the key factor being 300 at GEO rather than 700. The method of implementing crew rotation/resupply is illustrated in Figure 6.2-36.

The OTV used to rotate the crews and deliver supplies is a LO₂/LH₂ common stage system with the same operating and design characteristics as described for the GEO construction option. A smaller vehicle could be utilized (will be investigated in Part 2) for the crew rotation/resupply but by using the same size a direct comparison in terms of the number of flights required can be made. In this regard, 12 crew flights and 2 supply flights are required for LEO construction versus 28 crew flights and 6 supply flights for GEO construction.

The OTV (1 stage) start burn mass for crew rotation is estimated at 445,000 kg while the two stage vehicle for resupply would be 890,000 kg.

DDTE and TFU cost are estimated at \$950 million and \$82 million, respectively, which are the same as stated for the GEO construction option. Cost per flight, however, is different between the two construction location options primarily as a result of the different number of units required for the program as brought about by the different number of OTV flights. For the LEO construction case an equivalent of only 8 flights per satellite are required as compared with 314 for GEO construction (satellite plus crew rotation/resupply). To supply the LEO construction flight rate, only one upper and one lower stage are required rather than 4 upper and 2 lower for GEO construction. As a result, only 18 units rather than 624 units are required and thus the average unit cost is \$70 million vs. \$31 million for GEO construction. Consequently, the cost per flight for a two stage OTV for the LEO construction is estimated at \$5.5 million rather than \$2.26 million in the case of GEO construction.

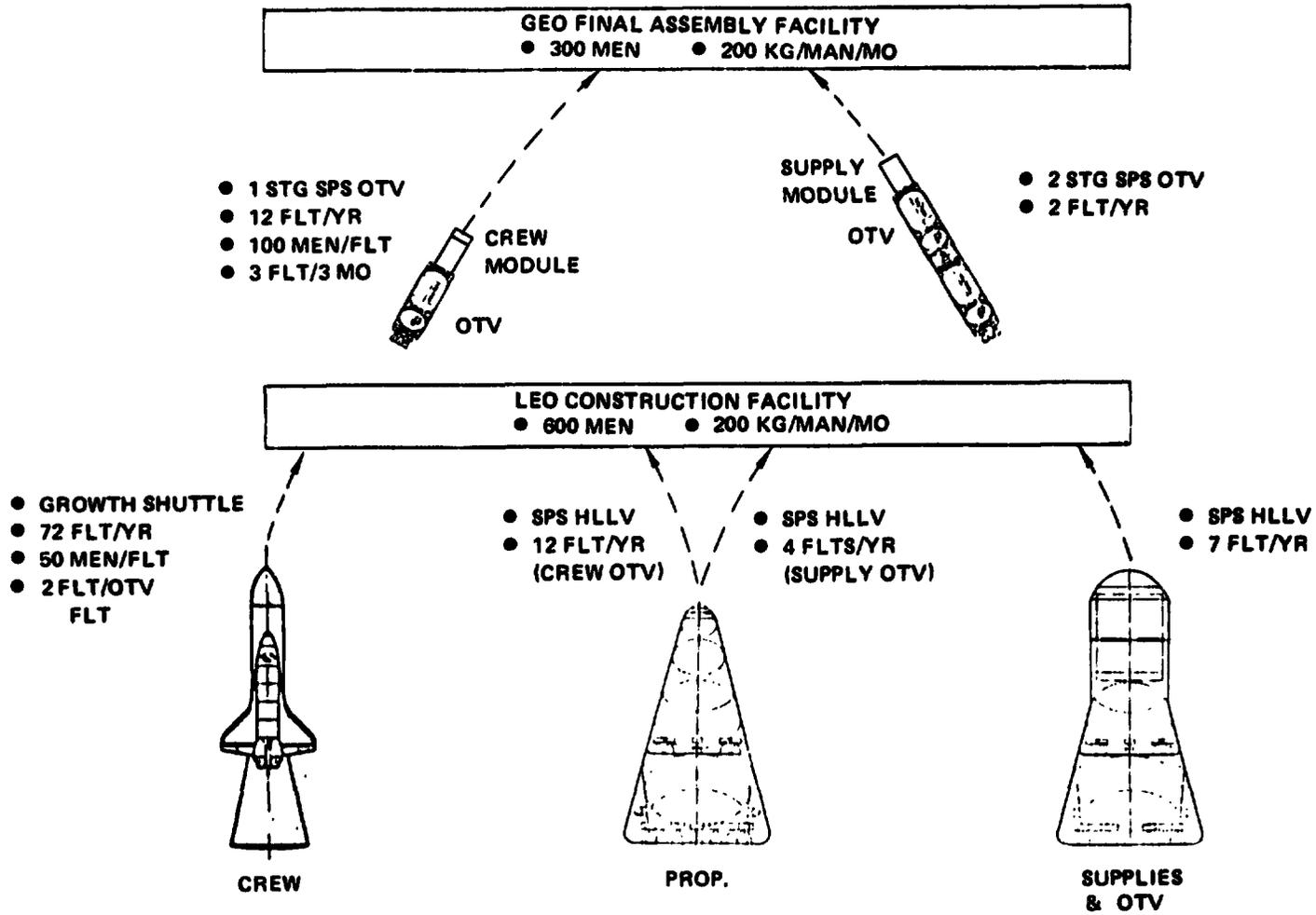

Figure 6.2-36 Crew Rotation/Resupply LEO Construction/Photovoltaic Satellite

221

ORIGINAL PAGE IS
OF POOR QUALITY

D180-20689-5

TABLE OF CONTENTS

	Page
7.1 LEO Transportation System Development Plan	223
7.2 GEO Transportation System Development Plan	226

222
7
PAGE INTENTIONALLY BLANK

7.1 DEVELOPMENT PLAN

The development plan for the SPS transportation system includes both the LEO and GEO transportation system elements.

7.1 LEO TRANSPORTATION SYSTEM DEVELOPMENT PLAN

The LEO transportation system requires the development of two vehicles, and they are the:

- SPS Freighter
- Personnel Carrier

However, in the evolution of the LEO Transportation system a number of considerations become apparent and these include:

- Phasing
- Commonality
- Utility

A program such as SPS will most likely evolve from an experimentation/feasibility demonstration, to a prototype demonstration and then to the full-scale commercial program. The current Space Shuttle System will support the early SPS program activities and an expanded payload capability version such as the Personnel carrier may be developed.

The large payload capability space freighter would not be required until later in the program. However, a new LO₂/hydrocarbon booster engine would probably be required for the Personnel Carrier and if the same engine would be suitable per the SPS freighter booster the overall cost and risk would be minimized. Parallel or simultaneous developments of new engines and airframes have historically tended to costly and problem prone. Based on these concepts a development plan has been generated which evolves the LEO transportation system elements.

The overall development schedule for the Personnel Carrier booster is shown on Figure 7.1-1. Since the rocket engine development period is approximately eight (8) years and the airframe is 4 to 5 years, an incompatibility exists. A solution, as depicted in the figure, is to develop the booster compatible with the new engine but to use the F-1 engine in the interim period to test, checkout and verify the airframe. ET and Orbiter modifications if required, would be performed in parallel with the booster airframe.

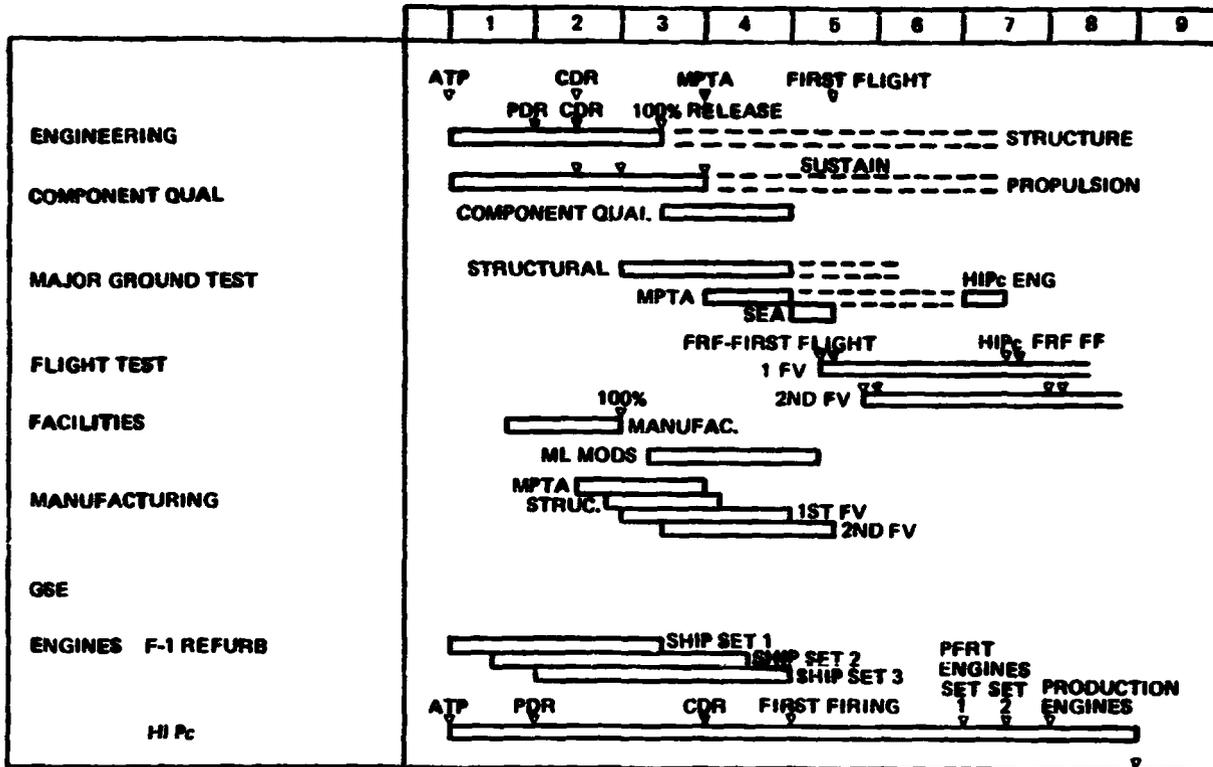

Figure 7.1-1 Personnel Carrier Development Schedule

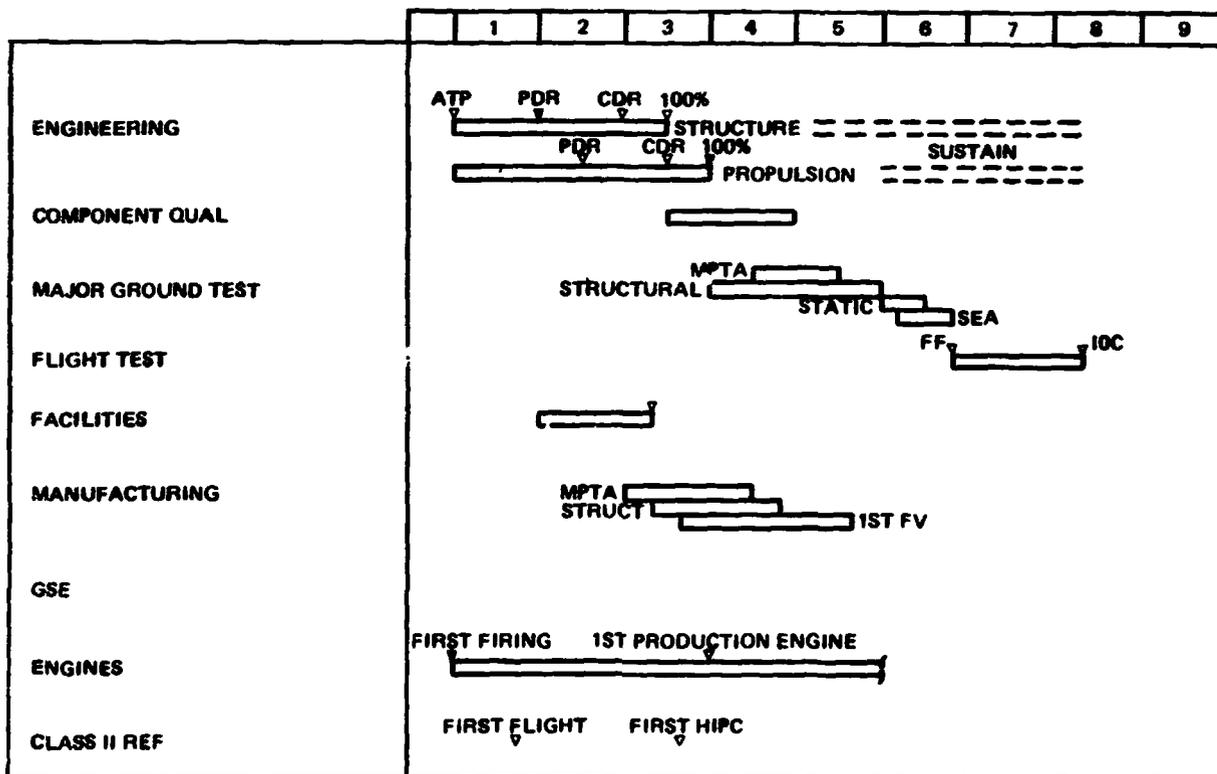

Figure 7.1-2 SPS Freighter Development Schedule

D180-20689-5

The SPS freighter development could begin as early as four years after the Personnel Carrier and have an initial operation capability within about 7½ years after ATP. The major elements of the SPS freighter development schedule are shown in Figure 7.1-2. The entire program from ATP on the Personnel Carrier through IOC on the SPS Freighter could be as short as 11½ years with a uniform phasing.

7.2 ORBIT TRANSFER VEHICLE DEVELOPMENT PLAN

7.2.1 Chemical OTV

The nominal development schedule is shown in Figure 7.2-1. This development includes a fluids transfer technology program to support design and development of on-orbit refueling systems. A total of eight years of design and development is indicated from the beginning of phase B to IOC. Several key requirements concerning the development of both the vehicle and engine is the need for space basing and at least 50 flights in terms of design life.

7.2.2 Electric Propulsion OTS

Development schedule for an electric propulsion orbit transfer system (OTS) is shown in Figure 7.2-2. The basic elements of this development schedule include the following features:

- **OTS Design Study**—Begins with orbit transfer system design requirements definition including interfacing with power source. Moves into phase B level study and preliminary design of all OTS elements including design of thruster labs/flight prototypes.
- **Thruster Lab Prototype**—Design, fabrication, and test and laboratory test articles for ionization chamber optimization and optics development.
- **Thruster Flight Prototype**—Design, fabrication, and checkout test of a flight test prototype thruster.
- **Flight Prototype System**—Design, fabrication, and ground test of power processors, propellant feed and control, and gimbal systems to support prototype flight tests.
- **Proto Flight Test**—Testing in low Earth orbit of the flight prototype OTS. Test objectives include system performance, flight control, and plasma effects. This test would employ a large power module (100-500 kw_e) as electrical power source and testbed.
- **Production Unit DDT&E**—Development of initial production OTS system design; fabrication and checkout of developmental production units.
- **Production**—Initial production run to support SPS developmental prototype.

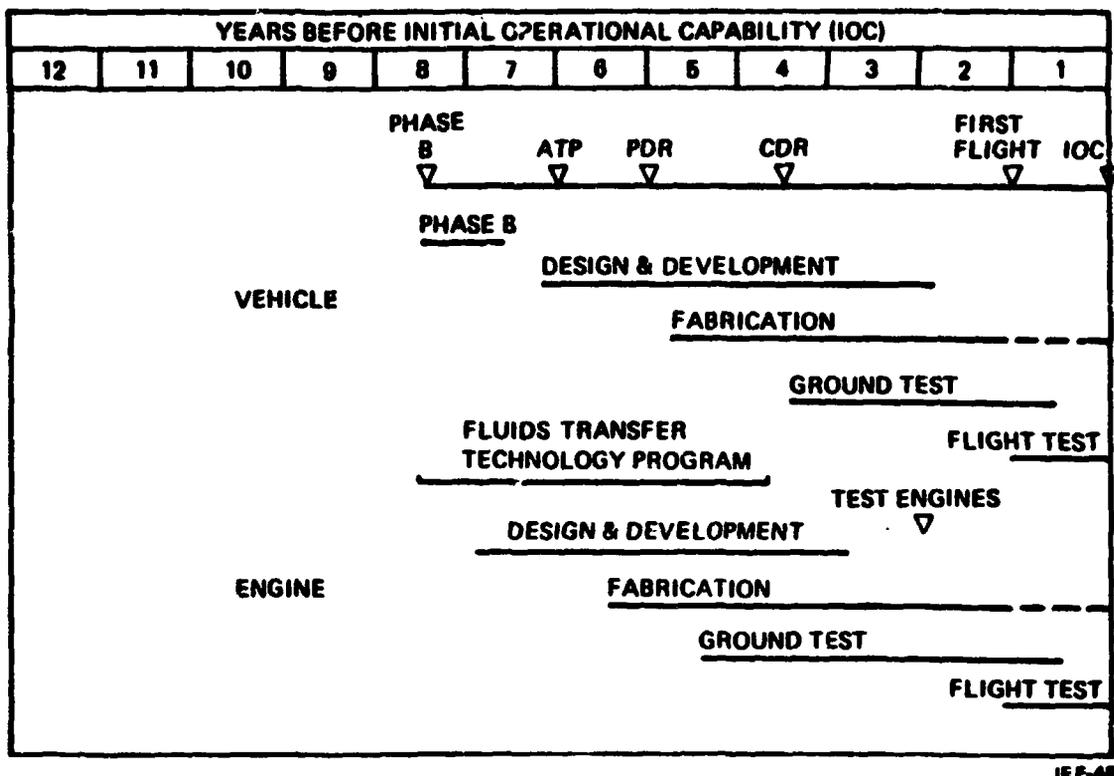

IEP-48

Figure 7.2-1 Common Stage LO₂/LH₂ OTV Development Schedule

ORIGINAL PAGE IS OF POOR QUALITY

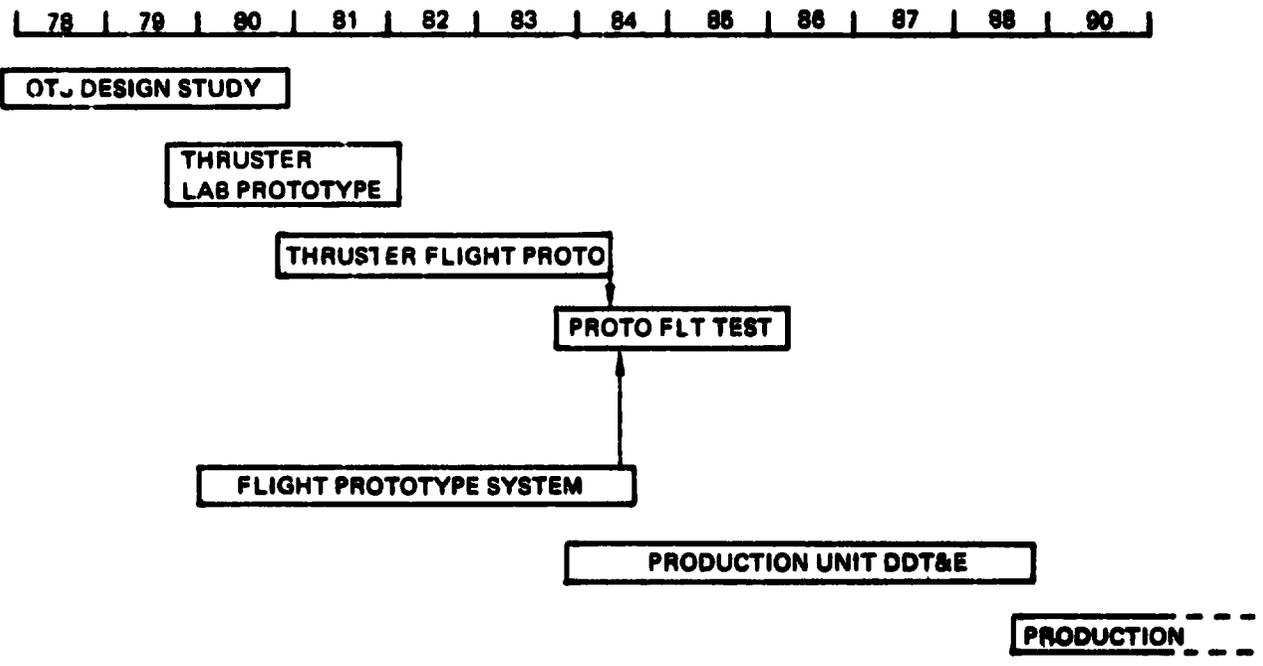

228

D180-20689-5

Figure 7.2-2 Electric Propulsion OTS Development Schedule

8.0 EXHAUST PRODUCT ANALYSIS

The objective of the Solar Power Satellite Study is the production of economical electricity without adverse environmental impact. It is therefore, especially important to determine what the environmental effects are so that they can be assessed and compared to alternatives.

One environmental concern is the release of chemical pollutants into the atmosphere, and the principal source of these are the exhaust products of the launch vehicle engines. The purpose of this study is to quantify the amounts of pollutants generated. Assessment of the impact will be left to a separate effort.

A preliminary analysis of the exhaust gas insertion into the atmosphere has been performed. The baseline transportation system used for this study is the 400 m.ton payload two stage recoverable ballistic/ballistic launch vehicle. So far, only booster products (LOX/Hydrocarbons) have been considered as the second stage ignition occurs above the stratosphere which is the principal region of concern. Initial conclusions are that production of objectionable exhaust products (principally CO, Hydrocarbons, and $(NO)_x$) will be proportionally less for the SPS transportation system than for Saturn or STS due to the use of advanced design liquid propellant engines.

The propellant pairs which have been considered for Launch Vehicles for SPS missions are liquid oxygen (LOX) with liquid hydrogen (LH_2) and liquid oxygen with various hydrocarbons. LOX/ LH_2 is used in the second stage of the baseline vehicle for this study. Although LOX/ LH_2 could possibly also be used as a booster propellant the baseline vehicle for this study uses LOX/Hydrocarbon.

Hydrocarbon fuel was selected since its high density allows smaller propellant tanks and smaller and lighter propellant pumps resulting in a smaller, lighter, and less expensive vehicle. These effects result in a lower transportation cost.

The combustion products of LOX/ LH_2 are only water (H_2O), hydrogen (H_2) and small amounts of free atomic hydrogen (H) and free hydroxyl radicals (OH). Some oxides of nitrogen are also produced by the reaction of atmospheric nitrogen with the exhaust products. The combustion products of LOX with hydrocarbons are more complex. The principal products are carbon dioxide (CO_2), carbon monoxide (CO), water (H_2O), and hydrogen (H_2). In addition, small quantities of a large number of other compounds and free radicals are produced. These include hydrocarbons, partially oxidized hydrocarbons, and free carbon. The reaction products will also react with the air to form oxides of nitrogen and possibly, very small amounts of organic nitrogen compounds. Due to the existence of additional reaction products, and due to the fact that second stage ignition occurs at 70.5 km (above the stratosphere) for the baseline vehicle, hydrocarbon fuels will be a greater pollution concern than hydrogen.

Whether or not a particular substance is considered a pollutant or not depends on the circumstances. Carbon monoxide, hydrocarbons and oxides of nitrogen are the principal concerns in urban air pollution and are the pollutants of interest for automobile engine exhausts. Hydrogen, water, and carbon dioxide on the other hand, are not normally considered as pollutants. Since the emissions from SPS launch vehicles will not be at ground level in urban areas but distributed over wide areas and at various altitudes from sea level to geosynchronous orbit, the same considerations may not apply. Water, for example, has been observed to have a dramatic effect on the ionosphere (Mendillo, M., Hawkins, G. S., and Klobuchar, J. A., "A Sudden Vanishing of the Ionospheric F-Region Due to the Launch of Skylab", Journal of Geophysical Research, 80,2217, 1975). Nitrogen oxides (NO_x) which are very offensive in urban areas are naturally produced in thunderstorms and are beneficial to the growth of plants in low concentrations. (NO_x) widely spread through the lower atmosphere may, therefore, not be objectionable.

Very little of the rocket exhaust gas is concentrated in the launch area. Observations of Titan III launches (Hart, William S., "Prediction of the Terminal Altitude and Site of Large Buoyant Clouds Generated by Rocket Launches", Aerospace Corp. Report No. TR-0066 (5115-10) -1, May 1, 1970) indicate that the exhaust products from about the first ten seconds of burn collect into a cloud roughly spherical in shape. The initial cloud is diluted about 250:1 with air. Since it is somewhat warmer ($\approx 25^\circ\text{C}$) than the surrounding air it is buoyant. The cloud rises from the ground within one minute and reaches an altitude of approximately one kilometer. Typically, the cloud dissipates without ever touching the ground. Under adverse conditions it may return to the surface (highly diluted) 100 km or more from the launch site. Ground clouds from solid rocket motors are of concern since they contain large amounts of hydrogen chloride (HCl). In some cases this has resulted in "acid rain" (HCl dissolves in the rain drops giving dilute hydrochloric acid). This cannot occur with the liquid propellants under consideration although some increases in the amount of dissolved CO_2 might occur.

In the lower atmosphere the exhaust gasses will be quickly diluted and spread through the hemisphere of the launch site. Even the large quantities involved for the SPS launch vehicles will have little effect on the global composition of the atmosphere. In addition, the concentration of all of the components of the exhaust products in the atmosphere are controlled by natural equilibria so that accumulation is unlikely to occur.

Of more concern is the effect on the stratosphere. In this region, (approximately 12 to 50 km altitude) horizontal mixing will occur rapidly, but vertical mixing is slow. Residence times of a year or more for typical exhaust products have been estimated. The density is so low that the quantities of exhaust products produced by launch vehicles is of more significance. In addition, the low densities result in such low reaction rates that free radical and other unstable species can exist for long periods of time. It is in this region that the ozone layer (which absorbs much of the sun's ultraviolet radiation) is considered particularly subject to damage by pollutants. Approximately 43% of the baseline launch vehicle propellants are discharged in the stratosphere.

D180-20689-5

Any consideration of pollutants must, therefore, include the particular circumstances and distribution of the pollutants as well as the total quantities produced.

The exact composition of even the gross components of rocket exhaust components for hydrocarbon propellants requires a rather elaborate analysis and depends on a number of factors which have not been finalized. These factors include: the particular hydrocarbon used, the engine chamber pressure, mixture ratio and expansion ratio. Results of an equilibrium analysis for some specific engines are available. Even if the exact composition at the nozzle exit is known, this still does not represent exactly the final products since the exhaust is fuel rich and secondary combustion will occur.

The determination of the final composition after secondary combustion would require an even more elaborate analysis based on a number of assumptions and approximations and would require extensive test data from actual engine operation for validation. The engine exit composition will be more representative for higher altitudes since the low densities will inhibit secondary combustion. In the absence of a detailed analysis and since the engine design has not been selected, only estimates can be made of the final exhaust products. Although approximations, these estimates can still provide bounds for an environmental impact assessment

A typical LOX/Hydrocarbon engine is the F-1. The particular hydrocarbon fuel used is RP-1 (approximately 86 wt percent carbon, 14 wt percent hydrogen). The mixture ratio is 2.27 kg of LOX per kg of fuel, the chamber pressure is 6.53 M Pa and the expansion ratio is 16:1. Estimated equilibrium exit exhaust gas composition for this engine is:

SPECIES	WT PERCENT
CO	38
CO ₂	33.6
H ₂ O	23.7
H ₂	1.50
H	2×10^{-4}
OH	2.8×10^{-4}
CHO	5.3×10^{-5}
CH ₂ O	3×10^{-6}
Unburned Hydrocarbons	3

The large amount of unburned hydrocarbons is partially due to the fuel rich gas generator used in this engine to drive the turbo pump. As pointed out above, the final composition of the products will be somewhat different. Part of the carbon monoxide, hydrogen and hydrocarbons will burn producing more water and CO₂. Also, some (NO)_x will be produced by mixing with the atmospheric air. It has been estimated that the amount of (NO)_x produced by the F-1 is about 0.4% of the exhaust gas mass in the troposphere (lower atmosphere) and about 0.002% in the stratosphere.

D180-20689-5

The lower production in the stratosphere is partly due to the lower density and partly due to the lower temperature of the more fully expanded plume. Although the total temperature of a rocket exhaust is quite high (about 3900°K for LOX/Hydrocarbons) the static temperature at the nozzle exit (which controls $(NO)_x$ formation) is much lower, about 2600°K for the F-1. It should be noted that since no air (and, therefore, Nitrogen) is available at the higher temperature regions in the combustion zone, rocket engines produce proportionately less $(NO)_x$ than piston engines or gas turbines.

The engines which would be used for an SPS Launch Vehicle will be of more advanced design than the F-1. Even if no environmental constraints are placed on the engine, performance considerations will tend to reduce the pollutant levels. Two of the changes which will be significant are higher chamber pressure and a different operating cycle.

Since the combustion temperature is essentially independent of the chamber pressure and since the higher chamber pressure results in a higher optimum expansion ratio, the plume boundary temperature will be lower, especially at altitude. For a 40:1 expansion ratio the exit static temperature is about 2000°K. The production of $(NO)_x$ will, therefore, be reduced. The level should be near or below the values for the Space Shuttle Main Engine which have been estimated at 0.01% in the troposphere and 0.001% in the stratosphere.

The operating cycle for the SPS Launch Vehicle engine has not been selected, however, it will not likely be a low pressure, hydrocarbon rich gas generator cycle such as the F-1. Two cycles under consideration are the staged combustion cycle in which all of the propellant mixture passes through the main combustion chamber and a tri-propellant system in which a LOX/LH₂ propellant mix is used in the gas generator. Either of these systems would greatly reduce the amount of unburned hydrocarbons.

TABLE OF CONTENTS

	Page
9.1 LEO Transportation Critical Commodities and Energy Requirements.	233
9.2 OTV Critical Commodities and Energy Requirements.	237

9.0 CRITICAL COMMODITIES AND ENERGY REQUIREMENTS

The usage of both critical commodities and energy for the transportation system can impact the programmatic of an SPS program. The impacts of both the earth to LEO and LEO to GEO transportation elements are discussed in the following sections.

9.1 LEO TRANSPORTATION COMMODITY AND ENERGY REQUIREMENTS

A preliminary assessment of these requirements has been conducted using the 2-stage ballistic recoverable concept as the reference vehicle. GEO assembly was selected as the reference construction option to investigate potential critical commodities due to the greater quantity of vehicles required.

Critical Commodities Assessment—In order to establish the commodity requirements the chemical element composition of typical rocket engines and airframes were investigated. The major alloys and their respective chemical element composition for rocket engines are shown in Figure 9.1-1. Nickel is used in the largest quantity (37.5%), followed by aluminum (13.5%) and chromium (12.8%). Nickel and chromium potentially could be candidate critical commodities if the usage is significant.

The majority of the vehicle airframe is aluminum or titanium. The main propellant tankage is 2219-T87 aluminum and titanium was selected for the unpressurized structure due to its high strength/weight ratio and excellent resistance to sea water corrosion. The chemical element composition of the majority of the airframe mass (83%) is shown in Table 9.1-2. Aluminum and titanium are the major chemical elements used with titanium being in excess of 50% of the airframe mass. Other aluminum alloys, such as the 5000 series, could be substituted for the titanium at a slight mass penalty but offer equivalent corrosion resistance.

For fourteen years of vehicle operations, the quantities of the major elements for engines and airframe are tabulated in Table 9.1-3. In addition, the typical annual requirements are compared to both the domestic and world annual production and known reserves. Only chromium, nickel, and titanium are used in any appreciable quantity compared to domestic production but none appear to be critical based on world production and reserves. Chromium annual demand would be $\approx 7\%$ of the domestic production but less than 0.1% of the annual world production. Nickel annual requirement is 19% of domestic production and 0.4% of world production. Annual production of titanium is classified by the producing companies but in 1976 U.S. consumption in aerospace industry was about 19500 M tons.

The vehicle annual requirement based on a comparison to last years aerospace consumption would be 40%. However based on world production (less U.S.) it would be 4% of the titanium produced. Reserves appear adequate for all the chemical elements assessed in this study.

D180-20689-5

Increasing vehicle design life and recycling the scrap material could lessen the impact on commodities. In addition, material substitutions and selection can vary the impact.

Energy Requirements--The major energy investment requirement for the LEO transportation system is the manufacture of propellants. The energy requirements associated with vehicle fabrication, refurbishment and replacement per 14 years of operations are only 47% of the propellant energy requirements for a single GEO assembled satellite or 1% of the total required for all the satellites installed in this time period. The annual energy requirements for propellant manufacture to support the JSC Scenario B installation plan (112 satellites) is shown in Figure 9.1-1.

The impact of the fewer launchers per satellite for LEO assembly is also noted in Figure 9.1-1.

Table 9.1-1 Typical Chemical Element Composition Of Rocket Engines - %

CHEMICAL ELEMENT	Al %	Cr %	Cb %	Cu %	Fe %	Mg %	Mo %	Ni %	Ti %	V %	Zn %	Zr %
ALLOYS												
ALUMINUM ALLOYS (7075 & A356)	13.24	0.05		0.25		0.08					0.76	
A-286		1.09			3.81		0.14	1.88	0.15	0.03		
INCONEL X		4.07	0.51		1.83			19.31	0.64			
HASTELLOY		7.62			6.61		3.05	16.27				
ZIRCONIUM COPPER				8.01								1.27
TITANIUM	0.25								3.43	0.15		
MASS FRACTION-%	13.49	12.83	0.51	8.26	12.25	.08	3.18	37.46	4.22	0.18	0.76	1.27

Table 9.1-2 Vehicle Airframe Chemical Element Composition

	Al	Cu	Ti	V	
ALUMINUM (2000 SERIES)	24%	1%			25%
TITANIUM	3%		52%	2%	57%
ELECTRICAL	0.5%	0.5%			1%
	27.5%	1.5%	52%	2%	83%

**ORIGINAL PAGE IS
OF POOR QUALITY**

9.2 OTV CRITICAL COMMODITIES AND ENERGY REQUIREMENTS

Chemical OTV's do not appear to have any materials which present a problem in terms of availability.

Self power electric propulsion systems only appear to have some concern in the area of thrusters where tantalum is used. This material is used in several areas of the discharge chamber and for housings that support propellant isolator-vaporizer assemblies. Based on a production rate of four satellites per year a total of 88,000 Kg of tantalum would be required assuming a one time use per thruster. There is no current U.S. mine production although world production (namely Thailand and several African countries) is approximately 450,000 Kg. Considering a 14 year program and four satellites per year, a total of 1.2 million Kg of tantalum would be required. Current world resources are estimated at 65 million Kg. The U.S. has about 1.5 million Kg of tantalum deposits, however, they are considered uneconomical in terms of 1976 recovery cost.

Several alternatives exist in reducing the amount of tantalum required should the availability be considered a problem. First, substitute materials could be used such as columbium for high strength application and titanium, moly, and columbium for high temperature application. A second alternative is the recovery and reuse of the electric thrusters which would reduce the basic material demand as well as reduce the effective cost per flight.

TABLE OF CONTENTS

	Page
10.1 Flux Model Analysis	239
10.2 Collision Analysis Results	241
10.3 Collision Avoidance Considerations.....	245
10.4 Junk Cleanup Concept	245

238
1
~~CONFIDENTIAL~~

10.0 COLLISION ANALYSIS

Consideration of space operations with objects as large as an SPS or SPS module raises questions of collision hazards. For historical space systems, even if as large as Skylab, the probability of collision with a manmade object is negligible, whereas the probability of collision with meteorites of potentially damaging size is appreciable. Vehicles like Skylab have accordingly been designed with suitable meteoroid protection, generally in the form of a "bumper" (impact armor). The flux of manmade objects in near Earth space, although small, is large enough to present a potential hazard to SPS's, and is orders of magnitude greater than the flux of natural objects of comparable relative kinetic energy. The flux of manmade objects is considerably greater at LEO than at GEO. Therefore, relative collision hazards enter into the selection of LEO or GEO as a construction location.

10.1 FLUX MODEL ANALYSIS

The idea that an SPS satellite can collide with another orbiting object is brought about by the fact that there were over 3700 man made objects in space as of late 1975. (1)

Most of these objects have apogee, perigee and inclination characteristics which can intersect an SPS satellite during the LEO construction phase and transfer to GEO. In addition, although the volume sweptout in one orbit of an object is quite small, that volume becomes quite large as the orbit of that object regresses sweeping out a volume bounded by the objects apogee, perigee and inclination characteristics.

The initial step in this analysis was to establish the flux model of objects per $\text{KM}^2\text{-sec}$ that will be encountered by an SPS satellite. A flux model is by nature a first-order statistical approximation to collision probabilities. More accurate models can be constructed, e.g. Monte Carlo simulations, but in view of uncertainties in source data, are probably not worth the added effort required. Several key assumptions were used in developing the flux model:

- (1) The distribution of objects in orbit as listed in the December 1975 Goddard Satellite Situation Report is representative of the future distribution;
- (2) $\text{Flux} = \frac{\text{(objects)}}{\text{KM}^2\text{-sec}}$ of objects in orbit is isotropic (true for low-medium altitudes); and
- (3) the size of any object in orbit is so small in comparison to an SPS, that the object is considered a point rather than a volume.

The flux contribution that each orbiting object makes was calculated as illustrated in Figure 10.1-1 using the following equation:

-
- (1) Satellite Situation Report - GSFC Volume 15, December 31, 1975.

The flux contribution that each orbiting object makes was calculated using the following equation:

$$\phi = \left(\frac{T_F}{VOL} \right) \times (VEL)$$

Where:

$$\phi = \text{Flux} \left(\frac{\text{objects}}{\text{km}^2\text{-sec}} \right)$$

T_F = fraction of an object's orbit time that is spent within a given "toroid," where each toroid is defined by an altitude and inclination band

VOL = The actual volume of the toroid (km^3)

VEL = the average velocity of an object within a given toroid. (km/sec)

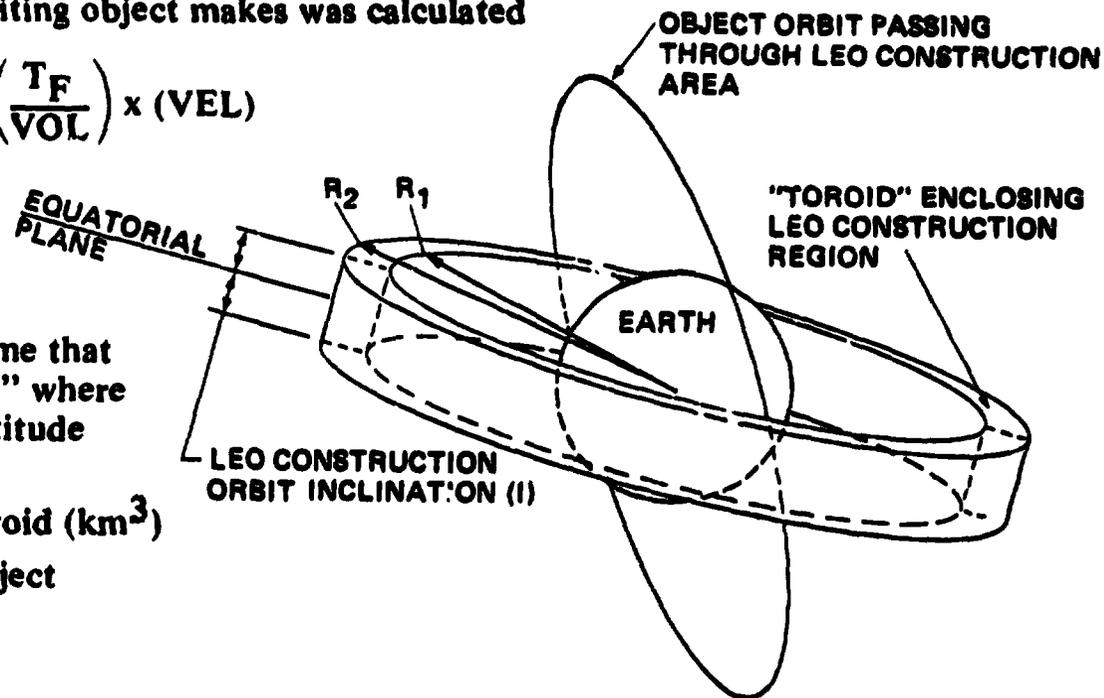

Figure 10.1-1 Orbiting Object Flux

240

D180-20689-5

ORIGINAL PAGE IS
OF POOR QUALITY

D180-20689-5

$$\phi = \frac{(T_F)}{VOL} \times (VEL)$$

where

$$\phi = \text{Flux} \frac{\text{objects}}{\text{KM}^2\text{-sec}}$$

T_F = Fraction of an objects orbit time that is spent within a given "toroid" where each toroid is defined by an altitude and inclination band.

VOL = The actual volume of the toroid (KM³)

VEL = The average velocity of an object within a given toroid (KM/sec)

The toroids considered in this analysis were bounded by the following altitude and inclination bands: Altitude (KM): 400-440, 440-480, 480-520 (LEO), 520-550, 550-600, 600-700, 700-800, 800-1000, 1000-1500, 1500-2000, 2000-3000, 3000-5000, 5000-10000, 10000-20000, 20000-35750, 35750-35890 (GEO); and inclination boundaries of (deg): 0-5, 5-10, 10-15, 15-20, 20-25, 25-30, 30-35.

Summation of the flux made by all objects within a given toroid results in the total flux a SPS satellite will encounter within a given toroid.

A computer program was used to perform the flux calculations for each of the specified toroids. The data were then combined within a typical SPS satellite LEO to GEO transfer trajectory (altitude vs inclination). This results in the plot shown in Figure 10.1-2, which indicates the flux encountered by the satellite. The highest flux is indicated at the 500 to 1000 KM region as would be expected due to the large number of satellites having perigees within this range. The relatively high flux at the GEO location is somewhat misleading, since the isotopic flux assumption becomes invalid, (most of the objects at or passing through this location are traveling at the same velocity and in the same direction as the SPS).

10.2 COLLISION ANALYSIS RESULTS

The collision model data reported at midterm were updated to reflect a "growth" object model (assumes the number of objects presently in orbit will increase due to continuing space launches) and modular construction with sixteen modules. The expected numbers of collision for one photovoltaic satellite and assumptions are shown in Figure 10.2-1. The 3x3 meter object assumption relates to calculations of collision cross-section for small SPS elements such as structure—the object model included all objects now listed in the Goddard Space Flight Center satellite situation report. In low Earth orbit, objects down to about 10 sq cm can be tracked.

Figure 10.2-2 shows a collision prediction for the thermal engine option similar to the previous figure for the photovoltaic option.

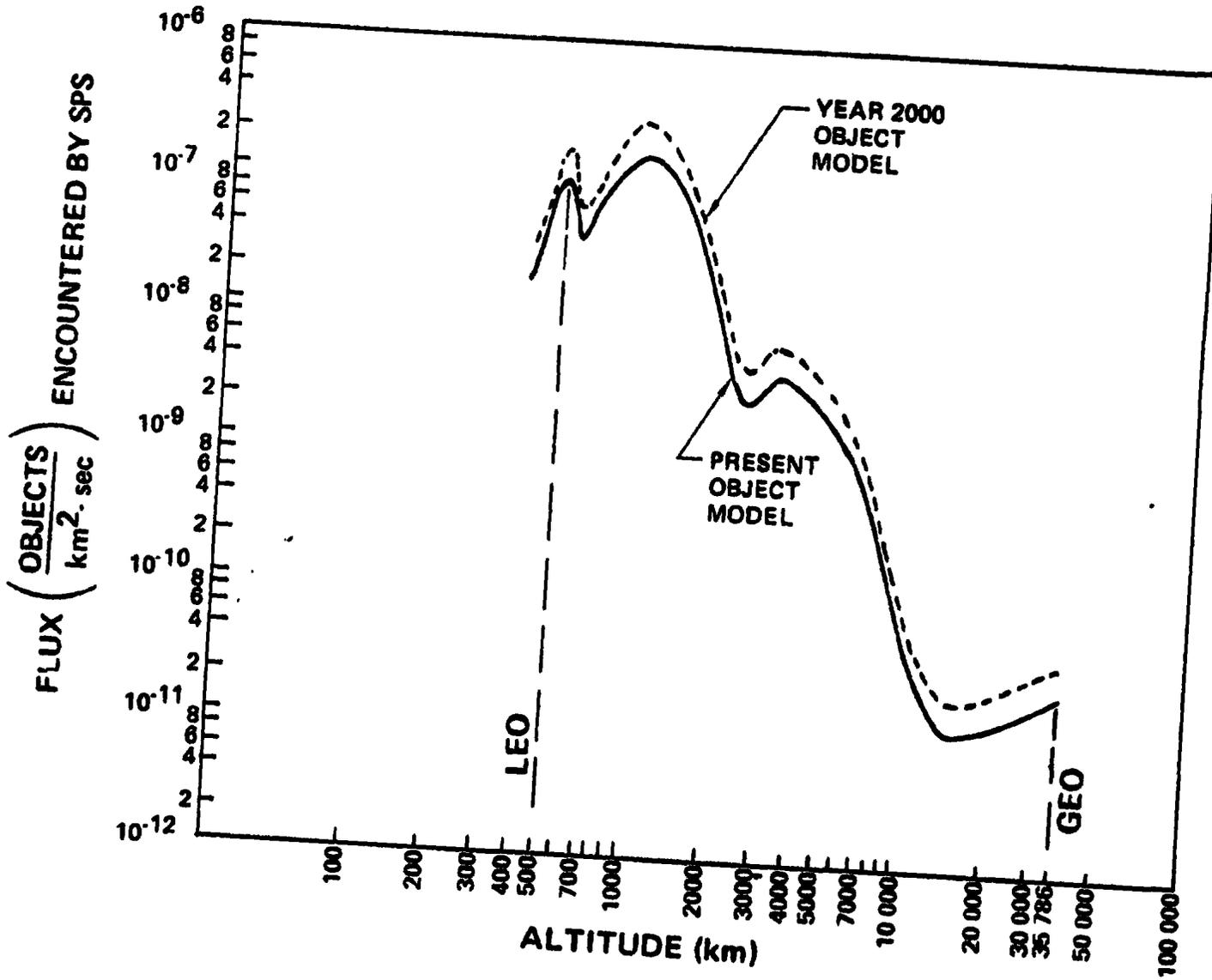

Figure 10.1-2 Object Flux Level

243

COLLISIONS ON ONE COMPLETE PHOTOVOLTAIC SPS (SIXTEEN MODULES)

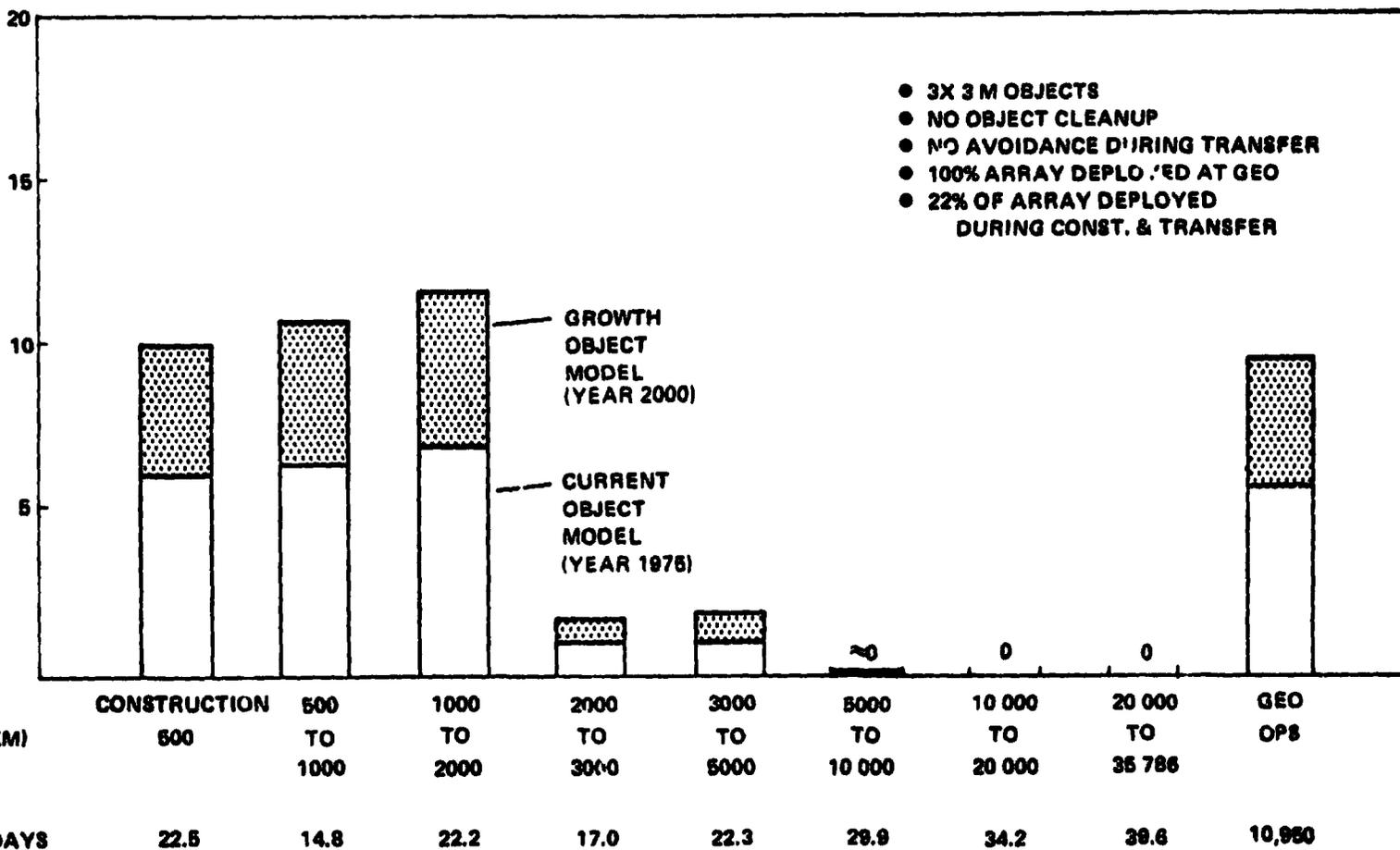
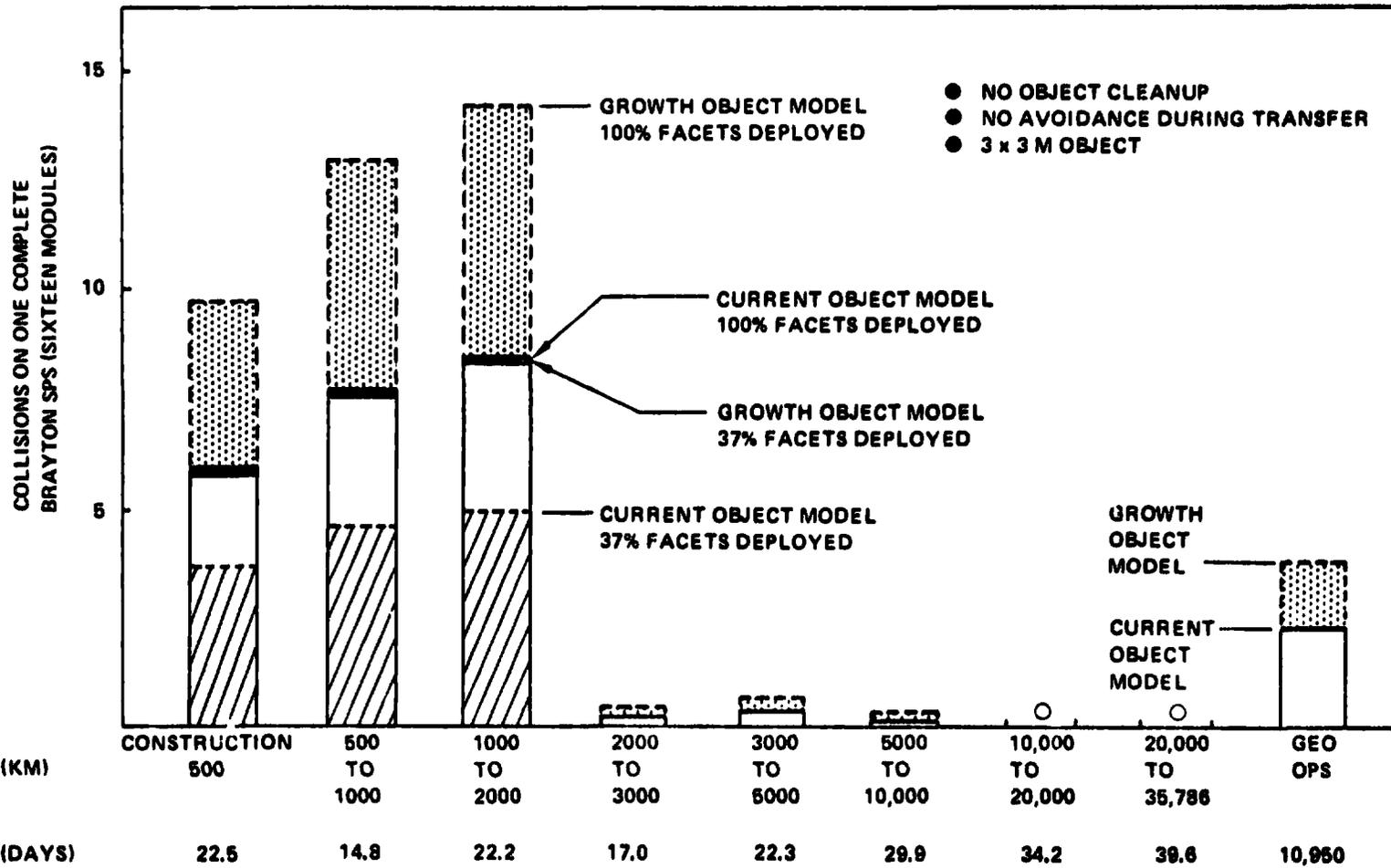

Figure 10.2-1 Number of Collisions for Photovoltaic Satellite

D180-20689-5

ORIGINAL PAGE IS OF POOR QUALITY

244



D180-20689-5

Figure 10.2-2 Number of Collisions for Thermal Engine Satellite

10.3 COLLISION AVOIDANCE CONSIDERATIONS

The flux model analysis presented above assumes no measures are taken to avoid collisions. During the orbit transfer outboard propulsion could be used for evasive action, either in changing the path of the transferring module or in changing its attitude to minimize the collision cross-section. The available propulsive acceleration is expected to be 5×10^{-4} M/SEC² or greater. This is sufficient to move an SPS module a distance equivalent to its own size in about 1 hour (linear acceleration assumption). Ephemeris of objects in LEO are known to roughly 50 meters, so adequate warning should be available for tracked objects. Avoidance maneuvers by the construction facility will be somewhat more difficult due to mass and altitude related considerations such as drag and radiation.

10.4 JUNK CLEANUP CONCEPT

As indicated earlier, most of the manmade objects are "junk" rather than operable satellites. Conceptual studies of a junk cleanup vehicle were included in the SEPS study program. This vehicle would propulsively match orbit parameters with junk objects (one by one), perform a noncooperative rendezvous, acquire the object with some sort of "grabber" and either deorbit it or return it to a controlled disposal area.

During the Part I SPS activity, an interceptor vehicle was suggested as an alternative. The interceptor would not rendezvous with the target objects, but merely fly into their path, a maneuver requiring far less delta v and propellant. The interceptor would employ a "catcher's mitt" to absorb the target objects energy by an inelastic collision. Various materials such as old mattresses, styrofoam, and water-filled plastic microballoons or tubing mats, have been suggested as catcher's mitt absorbers for the impact energy, momentum, and debris. For large objects, the catcher's mitt could be separated from the interceptor vehicle such that the collision would result in a velocity for the combined mass that is less than orbital velocity and thus would result in the decay and hopefully burnup during atmosphere entry.

246
n

11.0 TRANSPORTATION
COST COMPARISON

11.0 TRANSPORTATION COST COMPARISON AND SENSITIVITIES

Launch vehicle and orbit transfer vehicle descriptions in sections 5 and 6 respectively have treated cost generally independent of each other. Section 11.0 presents the total transportation operation cost for the LEO and GEO construction options. The reference launch vehicle used in this data is a two stage ballistic recoverable system with a cost per flight of \$6.9 million for GEO construction and \$7.5 million for LEO construction.

Transportation cost to GEO is compared in Figure 11-1 for five different satellite options. Cost is expressed as dollars per delivered KW to the ground for one satellite. For the photovoltaic satellites designed for beginning of life or end of life with array additions, the LEO option provides a cost savings of approximately 15%. For satellites less sensitive to radiation such as annealable photovoltaics and thermal engine satellites, transportation cost savings of 25 to 30% or 2.5 billion dollars per satellite is available through the LEO construction option. This comparison includes estimated cost penalties for the satellite modifications necessary to enable self-powered LEO-GEO transportation.

A transportation cost breakout is presented in Table 11-1 for one photovoltaic CR=2 annealable satellite. The most significant cost difference between the options is that associated with the HLLV operations required to deliver the orbit transfer systems and propellant. Further cost reduction for the LEO construction option are possible by treating programmatic cost as life cycle cost. In addition, recovery of electric thrusters and power processing systems may prove cost effective. These options could combine to reduce the cost of the LEO option by an additional 0.5 to 0.75 billion dollars.

Transportation costs to GEO for the two construction options can also be compared in terms of sensitivity to various program elements such as satellite mass as shown in Figure 11-2. The sensitivity of the chemical option (GEO construction) is approximately 75% greater to satellite mass than that of the electric orbit transfer vehicle option (LEO construction) for either the photovoltaic or the thermal engine satellite.

Another transportation cost sensitivity is related to LEO delivery cost as shown in Figure 11-3. The reference LEO delivery cost is approximately \$17 per kilogram. The total cost sensitivity to LEO delivering cost when using a chemical orbit transfer vehicle is approximately 90% greater than that of the electric orbit transfer system.

Transportation cost sensitivity to satellite quantity is presented in Figure 11-4. Basis for the satellite quantity is the JSC Scenario B which deals with as many as 112 satellites. Expressing costs as a function of the complete SPS program results in costs differences of approximately 250 billion dollars with the LEO construction/electric propulsion option providing the least costs.

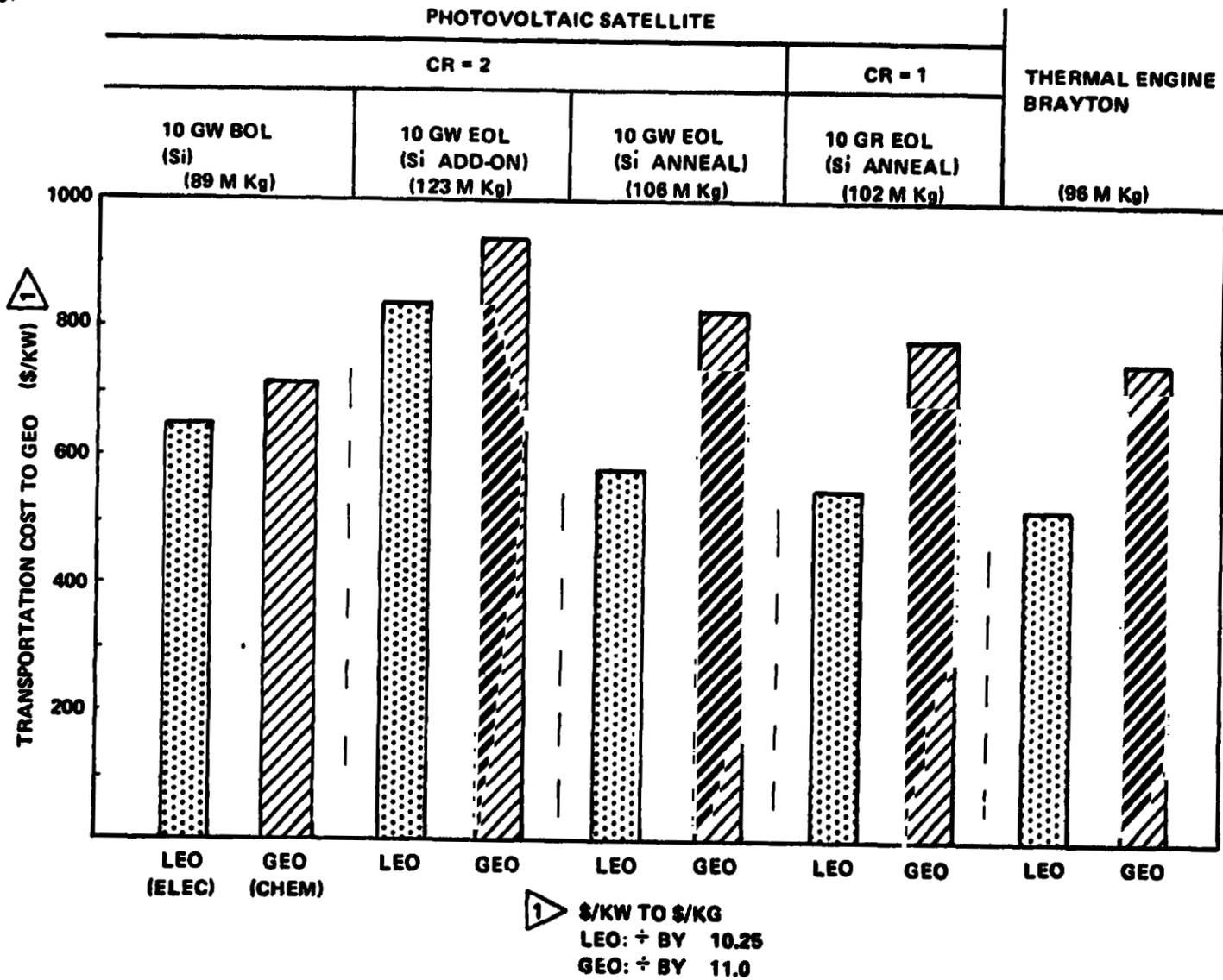

Figure 11-1 Transportation Cost Comparison Per Satellite

248 ORIGINAL PAGE IS OF POOR QUALITY

SPS 719

Table 11-1 Photovoltaic Satellite (Annealed) Transportation Cost

• SATELLITE COST IN BILLIONS

SYSTEM ELEMENT	GEO CONSTRUCTION	LEO CONSTRUCTION
• SPS HLLV	(6.77)	(3.40)
• SATELLITE	2.03	2.23
• ORBIT TRANSFER/ TANKER	4.43	1.01
• CREW ROTATION/ RESUPPLY SUPPORT	0.31	0.16
• ORBIT TRANSFER (RECUR)	(0.72)	(0.80)
• CREW	0.06	0.04
• SATELLITE	0.63	0.76
• SATELLITE MODIFICATION	-	(0.10)
• PROGRAMMATICS	(0.24)	(0.78)
• TRIP DELAY	-	0.55
• HLLV INTEREST	0.24	0.12
• OTHER INTEREST	-	0.11
• GROWTH SHUTTLE (CREW)	(0.70)	(0.79)
TOTAL	8.43	5.89
COST DIFFERENCE	\$2.58B	

**ORIGINAL PAGE IS
OF POOR QUALITY**

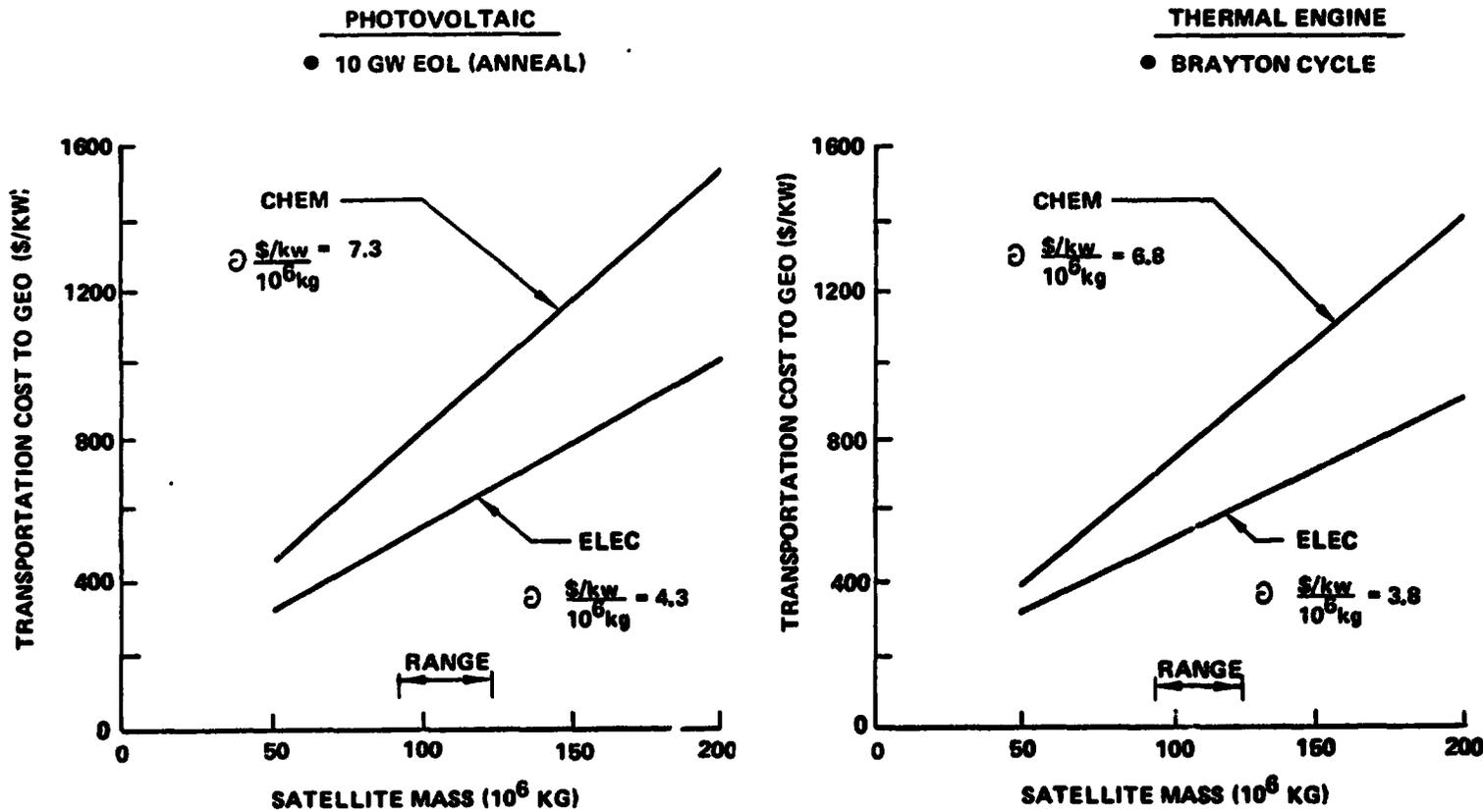
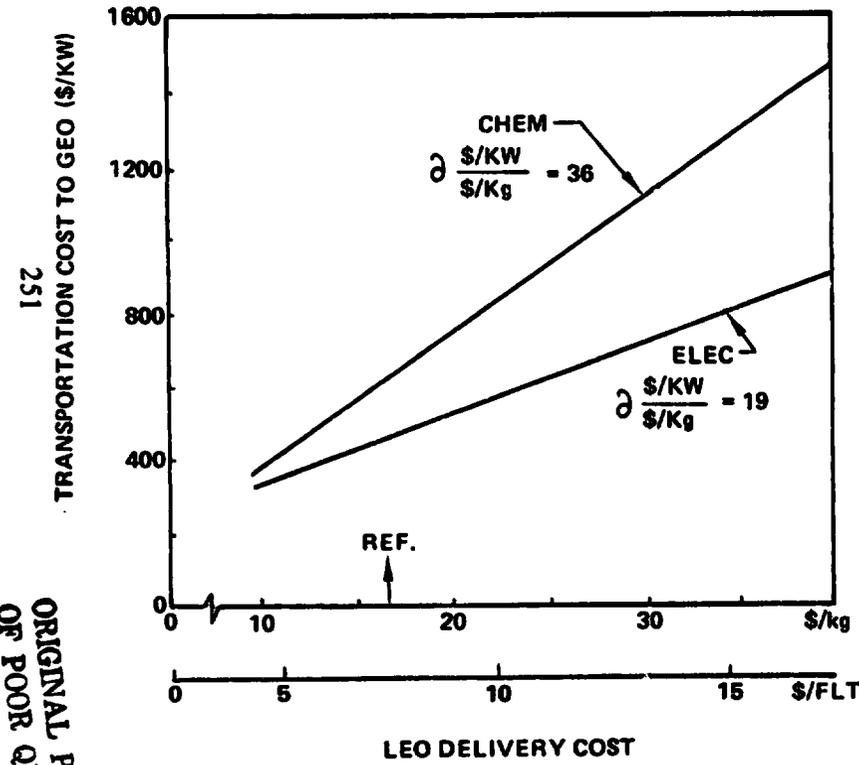

Figure 11-2 Transportation Cost Sensitivity to Satellite Mass

PHOTOVOLTAIC

● 10 GW EOL (ANNEAL)



THERMAL ENGINE

● BRAYTON CYCLE

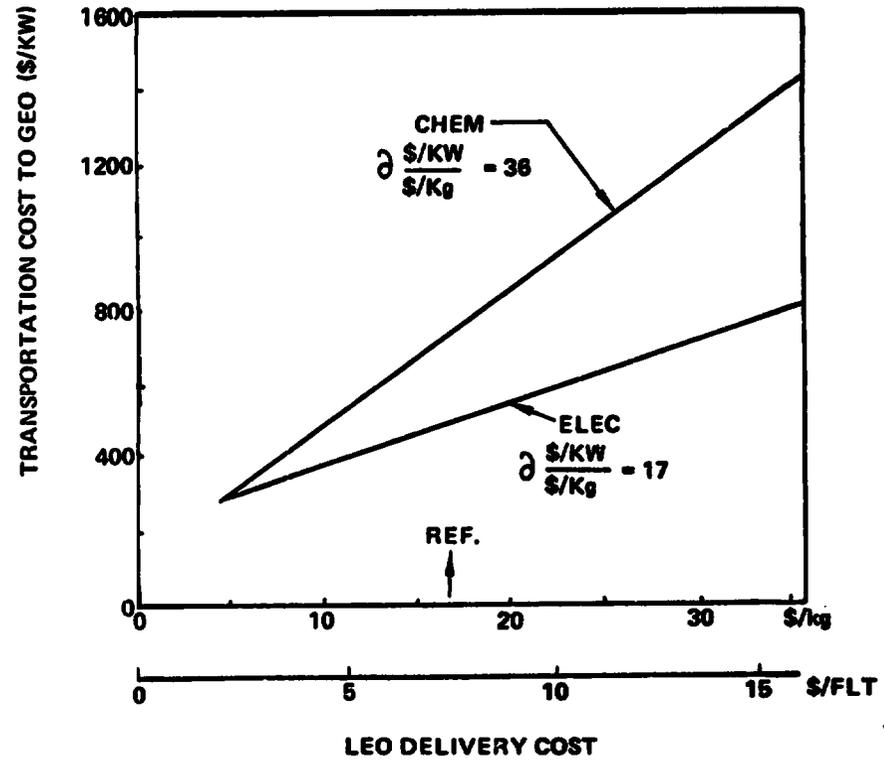

Figure 11-3 Transportation Cost Sensitivity to Leo Delivery Cost

D180-20689-5

ORIGINAL PAGE IS
OF POOR QUALITY

251

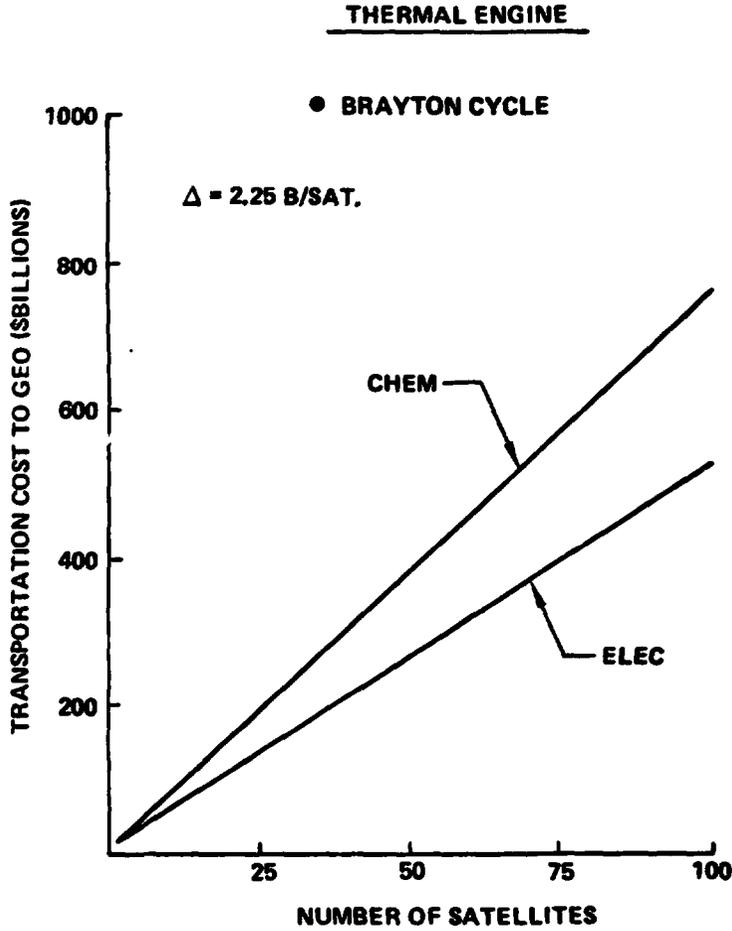
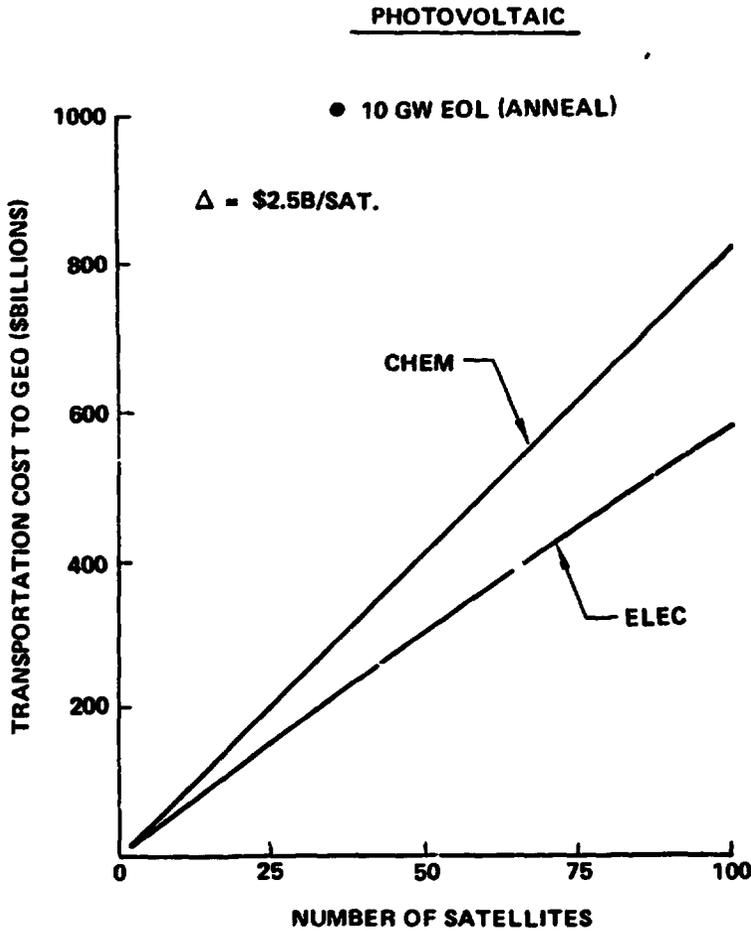

Figure 11-4 Transportation Cost Sensitivity to Satellite Quantity