

D13

N78-14603

APPLICATIONS OF THERMAL INFRARED IMAGERY FOR ENERGY CONSERVATION AND ENVIRONMENTAL SURVEYS

James R. Carney
Office, Chief of Engineers
Washington, D. C. 20314

Theodore C. Vogel
U.S. Army Engineer Topographic Laboratories
Fort Belvoir, Virginia 22060

Gordon E. Howard
Environmental Protection Agency
Environmental Photographic Interpretation Center
Warrenton, Virginia 22186

MAJ Earl R. Love
Facilities Engineering Support Center
Fort Belvoir, Virginia 22060

ABSTRACT

This report documents the results of a U.S. Government interagency study designed to determine the feasibility of using remote sensing technology to reduce the number of manhours currently required for energy conservation and environmental surveys. The survey procedures, developed during the winter and summer of 1976, employ color and color infrared aerial photography, thermal infrared imagery, and a handheld infrared imaging device. The resulting imagery was used to detect building heat losses, deteriorated insulation in built-up type building roofs, and defective underground steam lines. The handheld thermal infrared device, used in conjunction with the aerial thermal infrared imagery, provided a method for detecting and locating those roof areas that were underlain with wet insulation. In addition, the handheld infrared device was employed to conduct a survey of a U.S. Army installation's electrical distribution system under full operating loads. This survey proved to be a cost-effective procedure for detecting faulty electrical insulators and connections that if allowed to persist could have resulted in both safety hazards and loss in production.

The color and color infrared aerial photography aided in the interpretation of the thermal infrared imagery, provided a baseline of environmental conditions for future comparison, and provided a means to detect environmental problem areas.

The report also discusses the most efficient image scales and time of image acquisition, and concludes that remote sensing technology can reduce the cost and time required to conduct energy and environmental surveys.

INTRODUCTION

Our country's emphasis on energy conservation projects and environmental assessment programs has not been accompanied by adopting improved technological advances. The U.S. Army Intelligence and Security Command* (USAINSCOM) military installations as well as other Government installations are currently facing this emphasis with less resources than in the past. This paradox is the result of inflated labor and material costs, significant increases in utilities cost, and a reduced in-house work force.

Based upon experience of personnel within USAINSCOM, a program was developed that would use remote sensing aerial reconnaissance procedures coupled with ground surveillance for energy losses and environmental monitoring of military installations. In this regard, USAINSCOM contacted other Government research and development organizations for participation. As a result, the participating agencies in this program included the Environmental Projection Agency, Environmental Photographic Interpretation Center (EPIC), Warrenton, VA; U.S. Army Engineer Topographic Laboratories, Fort Belvoir, VA; and U.S. Army Intelligence and Security Command, Arlington, VA. Also, the Health Service Command's Health and Environmental Service (H&E), Fort Myer, VA, and the Health and Environment Activity (HEV), Fort Belvoir, VA, contributed in this joint pilot project.

*As of 1 January 1977, the U.S. Army Security Agency is now part of the U. S. Army Intelligence and Security Command.

Preceding page blank

OBJECTIVES. The purpose of this interagency endeavor was to demonstrate the feasibility and to determine the requirements for an environmental and operational assessment of U.S. Army installations. The major areas of interest investigated included, but were not restricted to, the following: grounds and vegetation including erosional features, utilities and structures, and sanitary/health considerations.

INSTALLATIONS. Two installations were selected for the survey: Vint Hill Farms Station, near Warrenton, VA, and Arlington Hall Station, Arlington, VA. Both of these stations are under the command of USAINSCOM and are representative of a typical rural and urban environment, respectively.

Vint Hill Farms Station. Vint Hill Farms Station is situated in the northeast corner of Fauquier County, VA, along State Route 215, two miles from the junction of State Route 215 and U.S. Route 15. The installation contains 720 acres of land distributed among the following general categories: improved grounds - 147 acres, semi-improved grounds - 362 acres, unimproved grounds - 116 acres, and forest lands - 95 acres.

The major sources of air emission at Vint Hill Farms Station are a 15.5 Million British Thermal Unit (MBTU) natural gas-fired heating plant, 472 small natural gas-fired heating units, gasoline storage tanks totaling 42,000 gallons capacity, and two refuse incinerators. Waste water from the installation is processed in two onsite sewage treatment plants.

Arlington Hall Station. Arlington Hall Station is situated within a residential area 5 miles from Washington, D. C., in the central part of Arlington County, VA, just south of U.S. Route 50. The installation is north of State Route 244 (Columbia Pike) and west of State Route 120 (Glebe Road). The installation contains 87 acres of land, of which approximately 35 acres are improved grounds; buildings occupy approximately 10 acres and parking, 25 acres. There are no water bodies on the post; storm drainage flows through a system of drains into Doctor's Branch Creek, but sewage wastes are disposed of through the Arlington County sanitary sewer system.

SCHEDULE. To determine seasonal variabilities, the investigation was conducted during both the winter (17 March to 6 April) and summer (28 July to 27 August) seasons of 1976.

TECHNICAL APPROACH

AERIAL IMAGERY. Three types of aerial imagery were acquired during the winter and summer phases of the program. The imagery included two types of aerial photography (color* and color infrared**) and thermal infrared scanner imagery.

The aerial photography was employed primarily to document environmental conditions as they existed during the study, provide a baseline of physical features at the two installations, and provide a means of updating the installation's basic engineering site maps.

Color infrared aerial photography is sensitive to reflected energy in both the visible and near infrared regions of the electromagnetic spectrum. Under certain conditions, this film is capable of detecting diseased and/or physiologically stressed vegetation, often before it can be detected from ground observation. This capability relies on a difference in the reflectivity that usually exists between healthy plants and those growing under some type of stress. The changes in reflectivity are related to the sensitivity of chlorophyll and internal foliar geometry to metabolic disturbances. As chlorophyll content decreases and internal foliar geometry changes, reflectance of the stressed plant tends to increase in the visible portion of the spectrum and decrease in the near infrared region.*** On a correctly exposed color infrared aerial photograph, these opposing reflectance changes initially create a magenta pattern with the color shifting to yellow and green as the stress increases. The healthy vegetation will image as light red or pink. There are a number of factors, however, that can affect the reflectance characteristics of vegetation other than disease or physiological stress even between plants of the same species. These factors include leaf thickness, orientation, and surface properties. This film has been used successfully in the past to detect diseases, the effects of insect attacks, nutrient deficiencies, drought, high soil salinity, and propane or natural gas leaks.

*Kodak Aerochrome MS, Type 2448.

**Kodak Aerochrome Infrared, Type 2443.

***E. B. Knipling, "Physical and Physiological Basis for the Reflectance of Visible and Near Infrared Radiation from Vegetation," Remote Sensing of the Environment, Vol. 1, pp. 155-159.

The two most important concepts to understand when interpreting thermal imagery are "blackbody" and "emissivity." A blackbody is defined as a perfect absorber of all incident energy with zero reflection. A theoretical blackbody, also, is a perfect radiator of energy and emits the maximum amount of energy possible for its temperature. Emissivity is the ratio of the energy radiated from a material to that of a perfect radiator or blackbody. The highest value of emissivity is unity (1.0), which occurs from a theoretical blackbody. On the other hand, a body that reflects all incident energy and absorbs or radiates none has an emissivity of zero. Carbon black is an example of a material with high emissivity. Building materials, vegetation, and terrain fall between these extremes and are termed gray bodies (table 1). When a surface such as a parking lot or roof is composed of a number of materials with each type of material having a different unknown emissivity, it is difficult to determine the absolute temperature of that surface from thermal imagery. In addition to this problem, the amount of moisture vapor in the atmosphere, wind direction, and velocity can attenuate the amount of infrared energy radiated to the airborne scanner. Normally, thermal imagery is presented to the interpreter such that light-toned patterns are represented as high temperatures, and dark or dense areas are represented as low temperatures.

TABLE 1. THERMAL RADIATION CHARACTERISTICS OF MANMADE MATERIALS

SURFACE	RADIATION	
	EMITTANCE %	ABSORPTION %
Asphalt, Black Paint	90 to 98	85 to 98
Concrete, Red, Brown, Green Paint	85 to 95	65 to 88
White Paint, Tile	85 to 95	30 to 60
Window Glass	90	4 to 40
Galvanized Steel	20 to 30	40 to 65

SOURCE: W. L. Wolfe, Handbook of Military Infrared Technology, Office of Naval Research, Department of the Navy, Washington, D. C., 1965.

BASELINE ENVIRONMENTAL SURVEY. The first requirement of an environmental survey or inventory is to establish a baseline or point of reference to which continuing environmental changes can be compared. The number and type of factors that the Facility Engineer has to monitor are specified in AR 420-10.* However, some of these specifications have to be varied according to the geographical setting of each installation. Obviously, such factors as water and air quality require that specific measurements must be obtained on the ground, but remote sensor imagery has the unique capability of documenting many of the factors that would be difficult and expensive to obtain by ground surveys. The old saying that "a picture is worth a thousand words" should be remembered here. Erosional features, vegetation mapping and vigor classification, and wildlife habitat surveys are only examples of the many environmental factors that can be monitored from aerial imagery. The ground data collection of this survey is summarized below.

Winter Phase. A survey of the water quality at Vint Hill Farms Station was conducted by the Fort Belvoir Health and Environment Activity on 18 March 1976 during the approximate time of the overflights. Water quality at Arlington Hall Station was not surveyed due to the absence of standing water and post sewage being piped to county treatment plants. Owing to equipment and time limitations, water samples were limited to the edges of the streams and lakes at Vint Hill Farms Station. The water samples were analyzed for biochemical oxygen demand (BOD), turbidity, specific conductance, apparent color, arsenic, lead, cadmium, and mercury. Temperature and pH were obtained at the time of acquisition. In addition, a survey was made of field service health and environmental conditions per AR 40-5** at both installations.

Summer Phase. The summer water quality survey was conducted in a manner similar to the one conducted during the winter phase by the Fort Belvoir Health and Environment Activity. Since each survey was conducted to determine indications of water pollutants, a point sampling method was used instead of a complete statistical sampling procedure. Care was taken, however, to sample streams where they entered and exited Vint Hill Farms Station so that the effect of the installation's runoff could be determined.

*U.S. Army, "Facilities Engineering - General Provisions, Organizations, Functions, and Personnel," Regulation 420-10, May 1975, Washington, D. C.

**U.S. Army, "Medical Services: Health and Environment," Regulation 40-5, September 1974, Washington, D. C. 1577

In addition to the water quality parameters surveyed during the winter phase, the summer phase also included total phosphates and a count of fecal coliform bacteria colonies.

ELECTRICAL SURVEY. Handheld thermal infrared imaging devices have been employed by electrical power companies for many years to identify potential problem areas. These thermal devices operate on the proven principle that there is a definite relationship between the temperature of an object and the infrared radiation emitted by the object. This equipment detects the infrared energy, converts it into video signals, and then projects the signals onto a monitor picture with the various shades of gray representing different temperature levels through a chosen temperature range. As with the aerial thermal infrared imagery, black corresponds to a colder temperature and white corresponds to a warmer temperature.

Loose or corroded connections, poor contacts, unbalanced loads, and loose bus joints introduce additional resistance into an electrical circuit causing these connections to have a temperature that is higher than normal. These "hot" connections are imaged on the thermal infrared equipment as white areas. The advantage of this survey method is that the electrical power is not interrupted during the survey.

The electrical survey starts at the point of delivery from the power company and proceeds along the main feeder lines to the final transformer, which serves a consuming facility. When the operator identifies a hot spot, the installation representative marks the location and probable cause on the installation's electrical distribution drawings.

ROOF SURVEY. The detection of moisture in flat built-up roofs with the use of handheld thermal infrared imaging instruments has proven to be one of the highest payoff applications of infrared technology. Previously, when a roof leaked and the leak could not be located easily, the entire roof was replaced. In most cases, repairing portions of a roof will correct the problem at a much lower cost than replacing the entire roof. To understand how infrared devices can be used to find wet areas in the roof, it is helpful to understand the construction of a built-up flat roof. Figure 1 is a cutaway drawing of a flat built-up roof showing the method of construction. A leak results when the moisture barrier develops a hole or tear, cracks occur due to age, or the flashings fail. When the moisture reaches the insulation through a failure of the moisture barrier or flashing, it can travel through the insulation with little interference. Interior leaks result when moisture passes through the insulation and the roof decking.

In addition to interior leaking, the wet material loses most of its insulation properties. This loss of insulation and the resulting increase in conductivity can be detected by the infrared equipment. During the winter when the building interior is heated, the wet insulation conducts heat at a faster rate than the dry insulation, thus increasing the surface temperature of the roof over the wet insulation. The infrared equipment is used to detect those portions of the roof that have a higher surface temperature.

The equipment can also be used when the building is not heated. Heat energy received from the sun will be absorbed and contained by the wet areas of insulation longer than the dry portions, thus creating a higher roof surface temperature. At night, when the heat loss by radiation is highest, those roof areas underlain by wet insulation can be detected because of their higher temperature.

After sundown, a ground infrared roof survey is more effectively accomplished in three steps. The first step is a review of the building drawings and a day inspection of the roof. The day inspection locates the obvious failures, provides general information on the condition of the roof, and enables the survey team to become familiar with the roof. In addition, safety hazards are noted since the team will have to walk the roof at night. The second step is the night infrared survey. The roof is scanned with the infrared equipment and the areas that appear to be warmer are outlined with white spray paint. Photographs are taken of the infrared image for documentation. The third step includes the documenting of the survey. Areas noted and marked with paint are sketched on the drawings.

DATA ACQUISITION

AERIAL IMAGERY.

Winter Phase. The acquisition of aerial imagery required two overflights for each of the two installations, one during the day and the other during the early morning hours. The first overflights were completed between the hours of 0430 and 0600 on 18 March 1976 at an altitude of 1,000 feet (305 meters) above the ground. During the period, three flight lines of thermal infrared imagery were acquired over Arlington Hall Station, and five flight lines were acquired over Vint Hill Farms Station with an AAS-27 thermal infrared scanner. The midday overflight was delayed because of poor weather conditions until the early afternoon of 18 March. This overflight was employed to obtain color and color infrared of both

installations at a scale of 1:2,000 simultaneously with two KC-1 cameras equipped with 6-inch (15 cm) focal length lens. With the exception of the midday overflights, weather conditions were exceptionally good for the acquisition of aerial imagery on 18 March. The air temperature was approximately -9.0°C with very little air movement, and the sky was free of clouds during the predawn flights.

Summer Phase. The imagery for this phase of the study was flown on 20 and 21 July 1976 with seven flight lines of photo and infrared imagery acquired at Vint Hill Farms Station and three flight lines acquired at Arlington Hall Station. An additional flight line was obtained at Vint Hill Farms Station at a scale of 1:4,000. As with the winter phase, weather conditions prevailing during the predawn and midday flights were excellent. Although the flight parameters and aerial cameras employed during the summer phase of the study were identical to those used in the winter phase, an AAD-5 thermal infrared scanner was used on 20 July instead of the AAS-27. Both of these scanners were operated in the 8- to 14-micron region of the electromagnetic spectrum, were uncalibrated, and were employed in the direct film record mode.

GROUND TRUTH MEASUREMENTS. In order to document ground temperatures, to provide a knowledge base for interpretation of the infrared imagery, and to provide a calibrated temperature source, an intensive ground data collection procedure was conducted at each installation during the period of aerial imagery acquisition. The procedure consisted of the following functions:

<u>FUNCTION</u>	<u>EQUIPMENT</u>
Surface Temperatures	PRT-10 Radiometer
Humidity	Psychrometer
Windspeed	Thermo-anemometer
Calibrated Temperature Source*	Thermometer
Internal Building Temperatures	Thermometer

In addition, the installation's engineering drawings were available. These drawings were of roof construction, utility distribution, and general site maps.

ELECTRICAL AND ROOF SURVEY. Two types of thermal infrared equipment were employed during the roof survey. The first was a device developed by the U.S. Army Night Vision Laboratory (NVL), Fort Belvoir, VA, as a tactical night vision aid. The second was developed by the AGA Corporation of Sweden.

The NVL equipment, designated PAS-10 (figure 10), is a thermal infrared device that operates in the 3- to 5-micron range of the electromagnetic spectrum. It weighs 9 pounds, is self-contained, and is battery operated. Although developed for tactical use, it has capabilities for the inspection of utility systems and roofs. This equipment has a real-time display, but photographs of the output can be obtained by mounting a camera against the single eyepiece and obtaining a time exposure. The cost of this equipment is approximately \$30,000.

The commercial infrared AGA equipment costs in excess of \$45,000 and weighs approximately 15 pounds. It also operates in the 3- to 5-micron portion of the spectrum and requires liquid nitrogen to cool the detector. Power is provided by an external battery pack, and the detector is held separately from the chest-mounted display portion of the equipment. A camera can be mounted within the viewing shield to provide a photographic record.

WATER QUALITY. The method and equipment employed in the water quality analysis is summarized as follows:

<u>FUNCTION</u>	<u>METHOD/EQUIPMENT</u>
Temperature	Thermometer
pH	Phenol Red Indicator, Taylor Chemical Color Comparator
BOD	Standard Method No. 219**
Oxygen Uptake	Agide Modification (Winkler Method)
Cadmium, Lead	Standard Method No. 129A, Perkin-Elmer Atomic Absorption Unit/Graphic Furnace

*Three 5-foot-diameter wading pools were located at each installation and maintained at each of three temperatures by continually adding warm water.

1579

**American Publishing Health Association, 14th Edition, "Standard Method for the Examination of Water and Waste Water," Washington, D. C., 1976.

<u>FUNCTION</u>	<u>METHOD/EQUIPMENT</u>
Arsenic	Standard Method No. 404A, B&L Spectronic 88
Apparent Color	<u>Water Analysis Handbook</u>
Total Phosphates	Spectrophotometer, Hack
Turbidity	DR 2, Turbidimeter, Hatch, Model 2100A
Conductivity	Standard Method No. 154 and 205, Beckman RC 16B2
Fecal Coliform Bacteria	Standard Method No. 909C
Dissolved Oxygen	Standard Method No. 422B. Fixed at site with manganese sulfate solution, alkali-iodine solution, and concentrated H ₂ SO ₄ . Titrated within 6 hours with sodium thiosulfate.
Mercury	Cold Vapor Technique*

DATA ANALYSIS

AERIAL IMAGERY. In summary, three types of aerial imagery were employed in the winter and summer phases of this study: Thermal infrared imagery, obtained before sunrise and again during the early afternoon; color and color infrared aerial photography, acquired within 8 hours of the thermal imagery. The color and color infrared photography in addition to providing information for the baseline environmental survey was also used to determine if temperature variations indicated on the thermal imagery were caused by standing water and to identify physical roof features such as heat vents, sky lights, and roof surface materials. The analysis of the data collected during the summer and winter phases, presented in the following paragraphs, includes three major steps: (1) Correlation of the three types of aerial image patterns; (2) Correlation and analysis of aerial image derived data with ground base measurement data; and (3) Confirmation of the results through onsite inspections by the facility engineers at each installation.

In viewing the thermal infrared imagery presented in this analysis, one should remember that the dark tonal areas represent cold surface temperatures and the light tonal areas indicate warmer temperatures. Also, the noticeable lineations that make up the thermal imagery are characteristic of optical electrical scanner imagery. All thermal imagery and photography presented in this report are fourth generation reproductions; therefore, some of the points discussed may not be evident in the illustrations.

Vint Hill Farms Station.

Figures 3 to 9. Figure 3 is a winter night infrared image of a portion of Vint Hill Farms Station showing Buildings 160 (E, figure 3); 162 (D, figure 3); 163 (K, figure 3); and 166 (A and B, figure 3). Figures 4 and 5, obtained during the summer phase, are day and predawn infrared images, respectively, and are essentially of the same area as figure 3. In general, the winter day thermal infrared imagery was of little value in this study. This was due primarily to excessive amounts of solar radiation existing during daylight hours but also to large amounts of standing water on the roofs during the time of image acquisition. Thus, the sensitivity range of the scanner was exceeded. Although figures 6, 7, and 8 are of the same area as figures 3 and 5, they are winter color** and color infrared photography and summer color infrared photography, respectively.

The roof of Building 166 (A, figure 3) and the connected utility room roof (B, figure 3), which contains a heating plant, are flat built-up roofs surfaced with similar roofing materials, tar and gravel. The utility building, however, is vented to ambient air. Ground measurements obtained at the time of image acquisition indicate that the external temperature of the utility room roof was -5.00C, while the roof of the main portion of Building 166 was -10.00C. This 5.00 variance in temperature between these two roofs can be seen in figure 3, A and B. The utility room roof (B, figure 3) is the warmer, indicated by its lighter tone. Ceiling temperature measurements obtained within Building 166 and the utility room were +10.00C and +14.00C, respectively. If the insulation value of these two roofs were the same, the utility room roof would appear as having a higher temperature, but not to the extent indicated on the imagery. Examination of the winter and color and color infrared photography did not reveal the existence of standing water on either of these roofs that would have contributed to this difference.

*Environmental Protection Agency, Office of Technology Transfer, "Methods for Chemical Analysis of Water and Wastes," Washington, D. C., 1974.

**Presented in these proceedings as black and white photographs to reduce the cost of publication.

In viewing the summer day infrared imagery (figure 4), no significant difference exists between the two roofs (A and B, figure 4). Ground temperature measurements, however, indicate a 5.0°C difference between these two roofs and a 13^o to 18^oC difference between these roofs and their background of grass-covered lawns. This 13^o to 18^oC temperature difference between the building roofs and their immediate background can be seen in figure 4.

The measured summer day temperature difference between the two roof surfaces (A and B) can be explained by the fact that the utility room roof was uninsulated, enabling solar energy to be rapidly conducted to the interior of the building. Normally, a 5°C difference in roof temperature would be within the sensitivity range of the scanner, but excessive solar radiation that exists during the day precludes the detection of small temperature differences.

The summer night thermal imagery also indicated the high thermal loss through the roof of the utility room (B, figure 5). The image, in this instance, correlated quite well with ground temperature measurements, which established the presence of a 3^oC difference in temperature between the roofs of the utility room and Building 166 (A and B, figure 5). The detection of this small temperature difference demonstrates the effectiveness of night versus day acquired infrared imagery. It also demonstrates that on a clear, cold, windless night the roofs of insulated buildings can be colder than both the internal building temperature and the external ambient air temperature (A, figure 5). The influence of air temperature, with little or no wind, is not considered as important as an unobstructed sky in the energy emission process of roofs. During the time of image acquisition, the temperatures of these two buildings were as follows:

	BUILDING A (Temperature °C)	BUILDING B (Temperature °C)
Roof	17	20
Internal	22	24
External Ambient	20	

The roof of Building A has a colder surface temperature than B because the heat flow from the building interior to the roof surface is retarded by insulation. In Building B, the internal to external heat flow to the roof is largely unrestricted; therefore, its temperature would be expected to be at or near that of the ambient air.

The large warm area (C, figure 3) is the discharge of a hot water hose that was employed to maintain three temperature reference basins. These basins, used to provide a known temperature reference, appear as three small white dots to the left of C in figure 3. It was anticipated that these basins could be used with optical microdensitometry techniques to obtain quantitative temperature data from the thermal imagery. Unfortunately, the image size of these basins was too small for practical use.

During the predawn winter flight, ambient air and grass temperatures were measured at -10^oC and the asphalt roadway, -8^oC. These temperature variations correspond to the gray tone patterns on figure 4. The amount of grass cover and other features, such as pathways and sidewalks that produce different tones of gray on the thermal imagery, can be better visualized by viewing the color and color infrared photography obtained during the same day (figures 6 and 7).

Using aerial infrared imagery for locating entrapped moisture within roof insulation employs the same concepts as those used by the handheld infrared equipment, e.g., insulation saturated with water will hold heat for a longer period of time than dry insulation. In figure 5, the two light-toned areas marked D are areas of wet insulation previously located by the handheld infrared equipment. Based on the results of this study and the realization that major thermal energy source for this process is the sun and not internal heat loss, the time of image acquisition becomes extremely important. In figure 3, for example, the wet areas are not images for two reasons: (1) the solar radiation from the sun is less in the winter than in the summer; therefore, the entrapped moisture is not heated to the same degree as in the summer season; and (2) most important, the time of this flight was 0420 hours, which was too late for maximum temperature contrast between the dry areas of insulation and the areas with entrapped moisture.

The relationship between the gray tones on the infrared imagery and the normal variables encountered on a roof surface such as light- and dark-colored roof materials, vents, surface water, and water within the insulation is evident on Building 160 (figures 6 and 7). Roof surface water is marked as E in figures 3, 6, and 7. On the top of roofs, water or moisture images as a dark color on the color photograph (figure 6) and as a black tone on the color infrared photograph (figure 7). The temperature of most of the roof surface water has

dropped to the same temperature as the roof by early morning (time of the winter night imagery), and only the deep pools of water provide a temperature contrast (figure 3). Two things become evident from a study of this image. First, to be most effective, the infrared flights should be scheduled earlier, approximately 1900 to 2200 hours. Second, roof surfaces should be free of standing water.

Steam line heat losses were also detected on the thermal imagery. An uninsulated expansion joint in an aboveground steam line can be seen as H in figures 3, 5, and 8. Underground steam line heat losses can be seen as I and Y in figures 3 and 5. The underground steam line leading from the heating plant (J, figure 5) to Building 160 (Z, figure 6) lies under the concrete sidewalk marked I in figure 5. The steam line marked Y in figure 5 is buried approximately 30 feet and then surfaces.

The relationship between emissivity, solar radiation, different roof surfacing materials, and their resulting gray tone characteristics on thermal infrared imagery can be seen in figures 3, 4, and 5. The corresponding winter color and summer color infrared photography (figures 6, 7, and 8) presents these same characteristics in the visual and near infrared portion of the electromagnetic spectrum.

The roof surface of Building 163 (K, figure 7) is a peaked asphalt, shingle roof that is dark green in color. The tone of this roof surface and the roof of Building 162 (D, figures 4 and 5) exhibit the same thermal image tonal characteristics. Roof D is a built-up roof surfaced with gray gravel. Although there is a variance in both the reflectivity and emissivity between these two roofs, roof construction differences have caused the roof surfaces to have the same image tones.

The thermal effect of different types of roof surface materials on Building 160 is indicated by M, N, and L, figure 4. The summer color infrared photo (figure 8) depicts a lack of surface water on this roof that would affect its thermal image.

In figure 8, roofs L and M are surfaced with a light brown gravel, and roof N is surfaced with a dark gravel. The day thermal image tonal differences (L and N, figure 4) are the result of varying amounts of thermal absorption based on light versus dark materials. The tonal differences of roofs L and M, figure 4, are due to differences in roof construction (as determined from the engineer drawings). Roof L has a dropped insulated ceiling that is adequately ventilated, and roof M (adjacent to N) has a dropped insulated ceiling that is not adequately ventilated. The second roof marked M is a normal built-up roof and does not have a dropped ceiling.

By early morning, buildings that are constructed with dropped insulated ceilings and are adequately ventilated will have roof surface temperatures near ambient air temperature as indicated by roofs L and N in figure 5. Although roof M appeared warmer than roof L on the summer day thermal imagery, it appears colder than L on the summer night infrared imagery because of greater heat flow retardation from the interior of the roofs labeled M.

Most of the temperature variances shown in figure 9 were attributed to the presence of standing water on the roofs. Color and color infrared photography also verified these areas of standing water. However, the thermal image of Building 426 could not be explained by a study of either the aerial imagery or the building's roof construction drawings. The explanation came from the residents of Building 426. Each evening an attic fan was turned on and left running all night, and the attic door was left open. Consequently, the total effect of the warm air being drawn from the lower floors of this building into the attic, even though the attic floor was adequately insulated, created a heat loss that was detectable by thermal infrared imagery.

Figures 4 through 14. The second portion of this survey involved the acquisition of baseline environmental data. Major subjects investigated using aerial imagery were forestry, grounds, wildlife, and sanitary health problems. Data collected on the ground were utilized with aerial photography during the analysis procedure. The advantages of using winter or summer photography depends upon the type of environmental feature that is to be studied. Land drainage patterns, coniferous trees and shrubs, erosion, landfills, and unimproved grounds can be identified more readily on winter photography. Vegetation stress, recreation areas, sewage treatment plants, and water points are better analyzed using summer photography. The inventory of wildlife cover and deciduous vegetation is most easily accomplished by comparing these features on both summer and winter photography. Selected environmental features were identified and located on installation site marks as follows: sewage treatment plant; coniferous trees and shrubs; deciduous trees; garden plots; land drainage; grasslands; wildlife cover; and tall mowed grass.

The forests surrounding Vint Hill Farms Station are primarily an oak/hickory/Virginia pine association with an occasional stand of pure Virginia pine. These forests and surrounding grass areas provide excellent habitat for a wide variety of wildlife. The list of animals actually noted during the survey included, deer, rabbits, squirrels, racoon, opossum, fox, hawks, turkey vultures, woodpeckers, and a variety of song birds. The large grass areas provide ample habitat for rabbits, mice, and moles. Several varieties of fish can be found in South Run, which flows along the northwestern edge of the post.

From the standpoint of actual problems, the post was very clean. The photographic analysis located two dumping sites and a salvage area. These areas were noted for continuous monitoring because of an unexplained high trace mineral content discovered in the water quality survey.

Arlington Hall Station. The same type of analysis of the aerial imagery was also conducted for Arlington Hall Station as has been previously discussed for Vint Hill Farms Station.

The most significant feature detected on the Arlington Hall Station imagery during the survey was the apparent amount of thermal energy being lost from the station's underground steam lines. These lines were installed approximately 20 years ago and are used to supply heat to most of the buildings within the installation. The Facility Engineer was aware that the conditions of those lines had deteriorated, but the scheduled repair was held in abeyance until the results of this study were available. The winter night thermal infrared imagery indicated a number of sections along this system where repairs or replacements were needed.

Entrapped moisture was detected on a number of roofs at Arlington Hall Station from both the winter and summer night thermal infrared imagery. Due to large areas of standing water on these roofs during the winter phase of the study, the summer thermal imagery proved to be more useful. As with Vint Hill Farms Station, an initial report, an overlay of suspected heat loss areas, and other problem areas were supplied to Arlington Hall Station Facility Engineer within 1 week of the overflights.

ELECTRICAL SURVEY. The electrical distribution systems at Arlington Hall Station and Vint Hill Farms Station were inspected on 12 to 15 and 17 to 18 March 1976, respectively. Although Vint Hill Farms Station had no electrical problems, there were five faulty connections discovered at Arlington Hall Station that required maintenance. Also a number of connections at Arlington Hall were found that appeared to be faulty, but upon detailed inspection proved to be the result of circuit imbalance. Figures 10 and 11 are presented to illustrate the ability of the infrared equipment to locate maintenance areas in a highly effective and safe manner. Figure 10 shows an electrical distribution pole containing high-voltage circuits. Figure 11 is a reproduction of the infrared display that indicates a faulty connection either at the cable termination or at the lightning arrester on the same pole.

ROOF SURVEY. The aerial thermal infrared imagery and aerial photographs of the two stations were analyzed in an attempt to identify those roofs that indicated a need for repair, i.e., showed indications of deterioration. During this analysis and review of the installation's engineer drawings, it was learned that only a few buildings at Vint Hill Farms Station had flat, built-up, insulated roofs. Time limitation precluded a complete onsite roof survey at either station; therefore, a building (No. 162) was selected at Vint Hill Farms Station for a detailed ground visual and thermal infrared survey.

The roof of Building 162, a barracks, had two areas that were indicated by the handheld infrared equipment to be underlain by wet insulations. The first area was associated with a guyed television antenna that was installed improperly, enabling precipitation to penetrate the moisture barrier (figures 12 and 13). The second area detected was near the roof parapet and was probably caused by an open joint in the flashing.

WATER QUALITY.

Winter Phase. With the exception of cadmium and mercury, the survey indicated normal concentrations of the other parameters. In view of the limited amount of sampling conducted and the fact that the mercury and cadmium concentrations were higher than expected but not at a dangerous level, these parameters were resampled during the summer phase.

Summer Phase. The analysis indicates that the total phosphate concentrations recorded at the sample points were greatly above the standards set for streams and water bodies. Total phosphate concentrations in a stream should not exceed 50 µg/l (micrograms per liter) at the point where it enters any body of water.* Although there are a number of mitigating factors involved in the determinations of the exact effects of phosphates on lakes and streams, these high values can cause an acceleration in eutrophication. All other parameters including cadmium and mercury were found to be at normal levels.

*U.S. Environmental Protection Agency, Quality Criteria for Water, 1976, Pre-Publication Copy.

DISCUSSION

At the installation level, the U.S. Army Facility Engineer is currently facing our country's increased emphasis on energy conservation and environmental protection programs with reduced resources and without the use of available technology. To develop an effective solution to this problem, a Government interagency team was formed to demonstrate the capabilities of remote sensing technology for detecting energy losses and controlling environmental pollutants. Major areas of study included in this demonstration were electrical distribution systems, structures, steam lines, grounds, forestry, fish, wildlife, and sanitary/health.

The technical approach utilized three types of aerial photography, ground surveys, and two USASA installations to examine the feasibility and to determine the requirements of an environmental and energy assessment of Army installations.

AERIAL IMAGERY. Successfully using remote sensing technology for environmental and energy loss surveys depends on the type, scale, and quality of imagery, weather conditions, type of collateral material available, and the knowledge of the image interpreter of the subject under analysis. Of these factors, the two considered most important are the availability of collateral information (construction drawings, etc.) and the interpreter's knowledge of the installation (which buildings are heated, locations and type of roof repair, etc.). As with any new technology, formal training in image interpretation would be beneficial, but during the course of this program, it was discovered that many of the patterns detected on the various types of imagery could readily be explained by the Facility Engineer staff of the two installations. In most cases, these questions were answered by reference to as-built engineering drawings, but many times the answer relied on the Facility Engineers' personal knowledge of their installations' maintenance and repair work.

The thermal imagery for this study was acquired between the hours of 0200 to 0500 and again at midday during the summer and winter seasons at scales of 1:2,000 and 1:4,000. Based on a review of the literature and the results of this study, it is now believed that the period of greatest thermal contrast between wet and dry areas of insulation occurs 2 to 3 hours after sundown, rather than during the predawn period. The major source of thermal energy that creates this thermal contrast is the sun and not internal heat from the buildings. In analyzing the effectiveness of day/night, winter/summer flight times, and the scale of the thermal infrared imagery, there are a number of factors to be considered. They include geographic location of the installation, size or area, and the location of the buildings within the installation. Obviously for locating thermal energy losses through the roofs of buildings, i.e., sky lights, roof vents, lack of insulation, the most effective time of acquiring the imagery would be at night and in the winter when the buildings are heated. As demonstrated in this study, thermal imagery acquired during the daytime is not effective for detecting either heat losses or wet insulation. Although the 1:2,000 scale imagery provided the interpreter with a more detailed picture to analyze, a scale of 1:4,000 would be more advantageous for three reasons. First, all heat loss areas detected on the 1:2,000 scale imagery could also be resolved on the 1:4,000 scale. Second, and most important, correlation between the three types of imagery is more efficient and manageable with the 1:4,000 scale because of the increased ground area covered. Third, the reduction in the amount of imagery obtained during succeeding years permits a more efficient design of image use, storage, and retrieval.

Weather conditions and the amount of standing water on the roofs are also important considerations when selecting the time of image acquisition. To obtain the maximum thermal differences on the ground, the sky should have less than a 10 percent cloud cover with a 0 to 4 miles per hour (0 to 6.4 km per hour) wind speed. Standing water on the roofs of buildings during the time of image acquisition can conceal areas of wet insulation and create false indications of energy loss. When possible, image acquisition should be delayed until all roofs are free of standing water.

The physical properties of roof surfaces, such as repaired or patched areas, variances in gravel color and density, and surface moisture can produce different tonal patterns on the thermal imagery, even though their surface temperature are uniform. If not properly identified, these patterns could be misconstrued as either areas of heat loss or wet insulation. Examination of the aerial photography and the as-built installation engineering drawings should provide the Facility Engineer with the essential information for the correct identification of each different tonal pattern on the thermal imagery.

The aerial photography, color and color infrared, was acquired simultaneously during the winter and summer phases of this study at a scale of 1:2,000. Although one film type may have been adequate, the additional information provided by the visible and near infrared regions of the spectrum in comparison with the small additional cost of acquisition was believed to be justified. Ideally, this photography should be obtained between the hours of 1000 and 1500 at a scale of 1:20,000 for environmental analysis and 1:10,000 for identification of the physical features or building roofs. The 1:2,000 scale photography proved to be almost unmanageable because of the excessive amount of photos acquired at this scale.

ELECTRICAL SURVEY. Using handheld infrared imaging devices, such as the PAS-10, will provide the Facility Engineer with an expedient, cost-effective means for determining the condition of an installation's electrical distribution system without interruption of power service. In many instances, an annual survey with this equipment could certainly reduce, if not eliminate, the chances of both unscheduled power and equipment failure by locating potential trouble areas in advance. In investigating the time involved in an infrared survey to that of the existing methods, it was discovered that a scheduled preventative maintenance procedure for electrical distribution systems did not exist for most installations. If such a procedure did exist, however, it would require approximately 10 to 20 times the number of manhours than a similar infrared inspection and, of course, would create numerous interruptions of service.

ROOF SURVEY. In addition to the electrical power, the PAS-10 can also be employed by the Facility Engineer to detect entrapped moisture within the insulation of flat, built-up roofs. Using this ground survey method in conjunction with aerial imagery can provide the Facility Engineer with a simple, efficient, cost-effective method of surveying the roof maintenance requirements of an entire installation in a very short period of time. By using aerial photography, the Facility Engineer can determine the physical appearance of any type of roof and determine, for example, the need for replacement of missing shingles or for replacement of a roof. Aerial thermal infrared imagery is employed to detect those areas of flat, built-up roofs that are probably underlain with insulation. Once the approximate location of a roof's moisture barrier defect has been determined from aerial imagery, an onsite roof survey can be conducted with the handheld infrared equipment to determine the exact location of the entrapped moisture.

A roof survey conducted by this method will not detect all the areas where maintenance is required; however, it will locate those areas that are in need of major repair.

In summary, remote sensing technology is not a panacea that can be used to detect all of the energy and environmental problems that can exist on an installation, nor can it presently provide quantitative information; however, it does provide the Facility Engineer with a valuable tool that can be used to detect problem areas that may have been overlooked during the ground inspection.

CONCLUSIONS

1. Aerial infrared imagery taken at scales of 1:4,000 and used in conjunction with a handheld infrared imaging device provides a cost-effective method for detecting and determining the area entrapped with moisture in flat, built-up roofs.
2. Aerial photography at scales of 1:10,000 used in conjunction with thermal infrared imagery and collateral information provide the Facility Engineer with an efficient, cost-effective method for detecting and characterizing thermal losses through the roof of buildings and associated utilities, such as steam lines.
3. Color and color infrared aerial photography obtained at scales of 1:20,000 can provide the Facility Engineer with a capability for establishing a baseline of environmental conditions and a method for monitoring potential environmental problem areas.
4. The handheld infrared imaging device provides an efficient, cost-effective method for surveying the maintenance requirements of an installation's electrical distribution system without disruption of service.

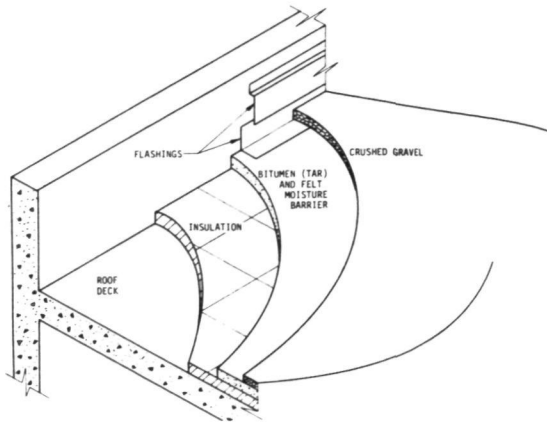

FIGURE 1.
CONSTRUCTION OF A BUILT-UP FLAT ROOF



FIGURE 2.
PAS-10 THERMAL INFRARED DEVICE

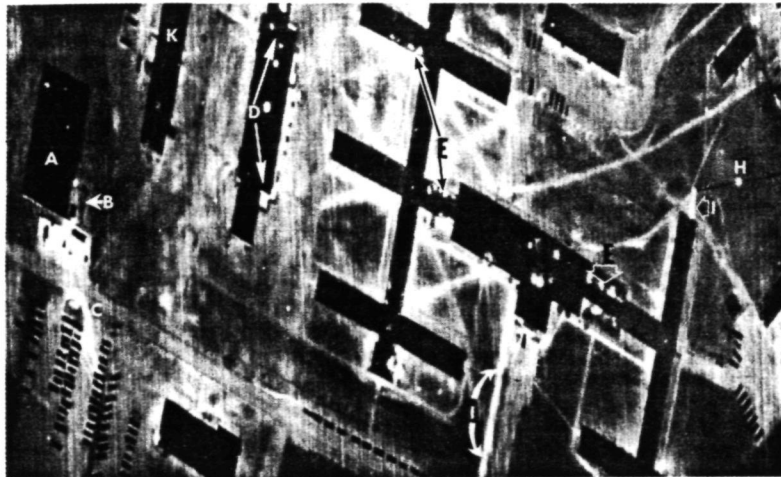

FIGURE 3.
AERIAL THERMAL INFRARED IMAGERY TAKEN AT 0420 HOURS ON 18 MARCH 1976

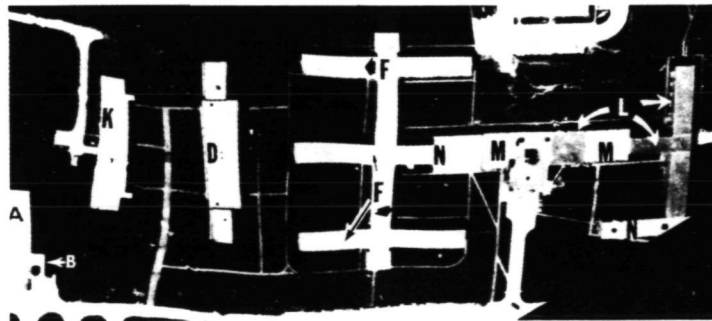

FIGURE 4.
AERIAL THERMAL INFRARED IMAGERY TAKEN AT 1530 HOURS ON 20 JULY 1976

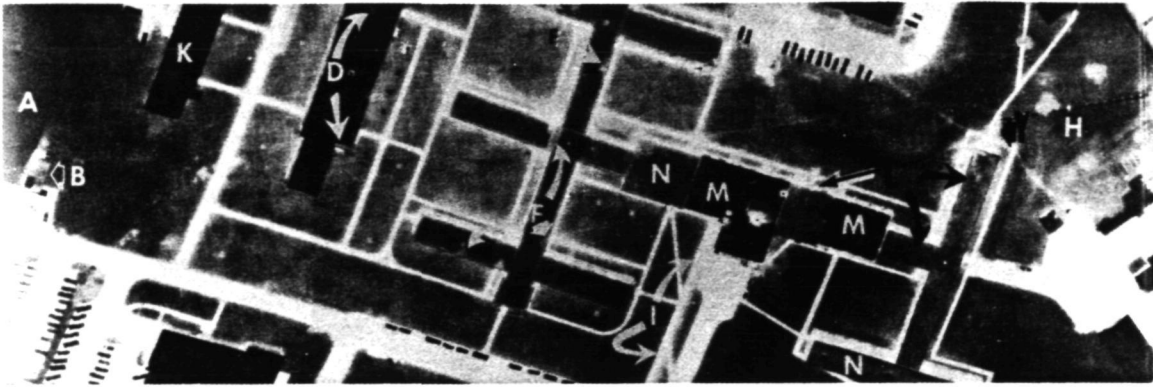

FIGURE 5.
AERIAL THERMAL INFRARED IMAGERY TAKEN AT 0450 HOURS ON 21 JULY 1976

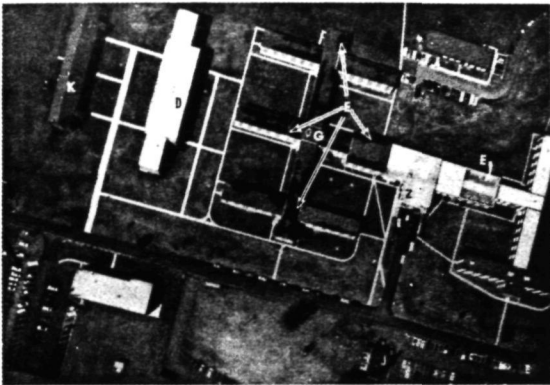

FIGURE 6. AERIAL COLOR PHOTOGRAPHY TAKEN
AT 1345 HOURS ON 18 MARCH 1976. SCALE -
1:2,000

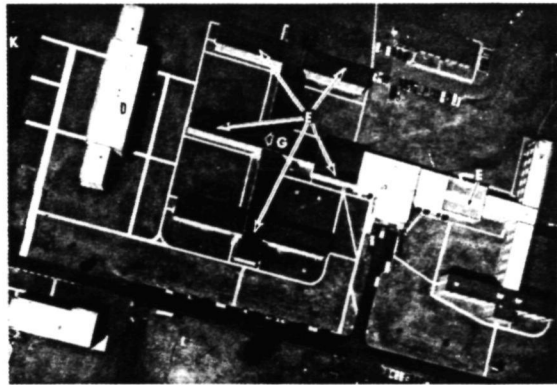

FIGURE 7. AERIAL COLOR INFRARED TAKEN AT
1345 HOURS ON 18 MARCH 1976. SCALE -
1:2,000

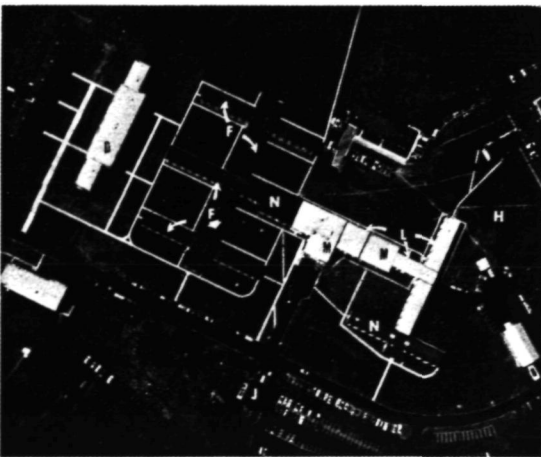

FIGURE 8. AERIAL COLOR INFRARED PHOTOGRAPHY
TAKEN AT 1530 HOURS ON 20 JULY 1976. SCALE -
1:2,000

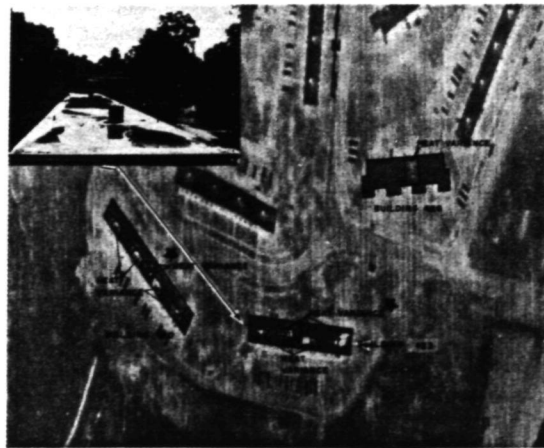

FIGURE 9. AERIAL THERMAL INFRARED IMAGERY
TAKEN AT 0430 HOURS ON 18 MARCH 1976

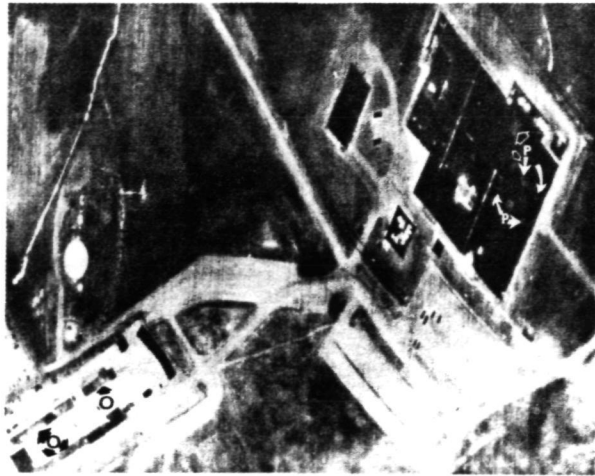

FIGURE 10.
AERIAL THERMAL INFRARED IMAGERY TAKEN AT 0430 HOURS ON 18 MARCH 1976

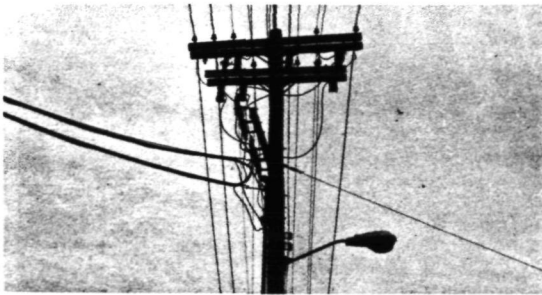

FIGURE 11. AN ELECTRICAL DISTRIBUTION POLE CONTAINING HIGH VOLTAGE CIRCUITS

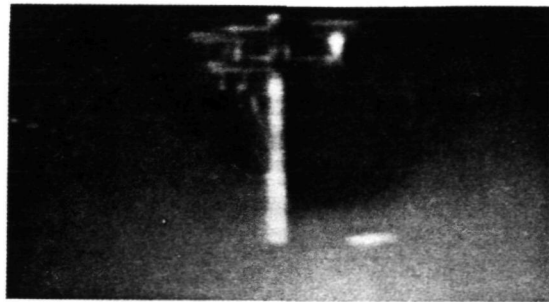

FIGURE 12. A REPRODUCTION OF THE INFRARED DISPLAY INDICATING A FAULTY CONNECTION



FIGURE 13. AN ANTENNA INSTALLATION OF BUILDING 162, VINT HILL FARMS STATION. AREA OUTLINED IS UNDERLAIN BY WET INSULATION.

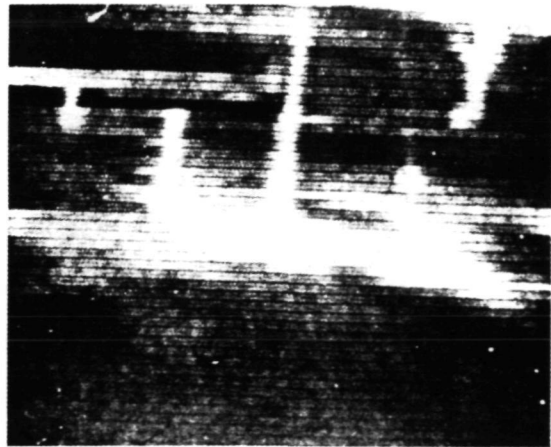

FIGURE 14. INFRARED DISPLAY OF WET INSULATION AREA ON BUILDING 162 CAUSED BY FAULTY INSTALLATION OF TELEVISION ANTENNA