

THE OPERATIONAL PROCESSING OF WINDESTIMATES FROM CLOUD MOTIONS:PAST, PRESENT AND FUTURE

C. Novak and M. Young

U.S. Department of Commerce, NOAA
National Environmental Satellite Service
Suitland, Maryland 20233

ABSTRACT

The development of operational procedures for the extraction of wind estimates from cloud motions observed in geostationary satellite data has been an evolutionary process. In 1969, the first operation was instituted at NESS using visible pictures from the ATS-1 and ATS-3 satellites. Operational procedures consisted of the viewing of an animated film loop by a meteorologist who determined the beginning and end points of the cloud displacements. The conversion of displacement end points to earth located high and low level wind estimates was crude, cumbersome and subjective. These procedures provided approximately 300 wind estimates per day to a very small user community.

Current NESS Winds operations provide approximately 1800 high quality wind estimates per day to about twenty domestic and foreign users. This marked improvement in NESS Winds operations was the result of computer techniques development which began in 1969 to streamline and improve operational procedures. In addition, the launch of the SMS-1 satellite in 1974, the first in the second generation of geostationary spacecraft, provided an improved source of visible and infrared scanner data for the extraction of wind estimates. Currently, operational Winds processing at NESS is accomplished by the automated and manual analyses of infrared data from two geostationary spacecraft. This system uses data from SMS-2 and GOES-1 to produce wind estimates valid for 00Z, 12Z and 18Z synoptic times.

As for the future, development of automated winds processing techniques will focus on the extraction of high- and low-level wind derivations with temperature/height estimates and the use of objective procedures for the quality control of the wind estimates. Development of manual techniques will focus on the implementation of a Man/Machine Interactive Processing System (MMIPS) approach to satellite wind extraction. The MMIPS will provide the use of digital data for time-lapse animation and permit greater interaction between the meteorologist and the main computer complex for winds derivation and quality control. An outlook of the processing capabilities for the First GARP Global Experiment (FGGE) is provided.

1. INTRODUCTION

With the launch of the first geostationary satellite, ATS-1 in 1967, meteorologists began to analyze the first full disk images of the earth and its cloud patterns. It occurred to some meteorologists that if time lapse film loops could be made, the dynamic aspects of these cloud patterns could be

studied and related to various weather phenomena. Pioneers in the field of cloud motion analysis and its relationship to wind fields included Dr. Verner Suomi of the University of Wisconsin and Dr. Tetsuya Fujita of the University of Chicago. They concluded that two levels of cloud motion, cumulus level and cirrus level, could be easily analyzed and they began to develop techniques for relating these motions to the low and high level wind fields. The results of their experiments were evaluated by Hubert and Whitney (1971). They compared the derived cloud motion vectors with co-located rawinsonde reports and determined that low level cumulus clouds best matched rawinsonde reports at 914 meters and high level cirrus clouds fit best at 9114 meters. Median vector deviations of cloud motions from rawinsonde reports at those levels were 5 mps and 9 mps respectively. These tests indicated a high correlation between cloud motion analysis and rawinsonde derived wind data.

2. YESTERDAY'S OPERATIONAL SYSTEM

In order to track cloud motion tracers, meteorologists prepared latitude-longitude gridded, time lapse film loops of approximately 2½ hours duration and projected the animated cloud motion sequence on a paper worksheet. Meteorologists then selected those cloud tracers which seemed to be moving with the high and low wind fields and marked their start and end points on the worksheet. In order to measure the wind speed, the analyst placed a clear plastic template, calibrated to the lat-lon grid, over the end points and determined a preliminary speed value. In order to rectify the flat plane film projection to the earth's spherical coordinate system the meteorologist had to add a speed correction as a function of each vector's distance from the satellite subpoint. Similarly, the meteorologist used a clear plastic compass and manual corrections to estimate direction of motion.

Since the Applications Technology Satellites carried only visible sensors, operations were limited to the daylight hours. The north and south Atlantic Oceans were analyzed at 1800GMT and the Pacific areas at 0000GMT. During the period 1969 through most of 1971, the combination of cumbersome manual techniques and daylight analysis limited the production of satellite derived winds to approximately 300 per day.

These data were used in the tropical analysis model at the National Meteorological Center. The model's developer, Dr. Harold Bedient, found that satellite derived winds were useful for providing reliable and meteorologically sound data over tropical oceans and other data void areas.

3. OPERATIONAL IMPROVEMENTS IN THE 1970'S

3.1 COMPUTER TECHNOLOGY

The implementation of computer techniques in the operation served to free the meteorologist from the drudgery of routine analysis and hand calculation and permitted him to concentrate on the analysis of complex meteorological phenomena. In October 1971, computer techniques were implemented at NESS which provided for the automation of the hand calculations necessary to transform vector end point data to earth located wind estimates (Young et. al. 1972). Techniques development conducted by Bristor et. al. (1967) and Leese et. al. (1970) demonstrated the feasibility of measuring cloud motion displacements by computer methods. This work laid the foundation for the development and operational implementation of an automated procedure providing for the derivation of low level wind estimates (Bradford et. al. 1972).

3.2 ADVANCES IN SATELLITE TECHNOLOGY

The launch in August 1974 of the first in a series of Geostationary Operational Environmental Satellites (GOES) provided infrared data for the derivation of wind estimates. This improved source of data permitted the analysis of night time cloud motion displacements. In addition, the infrared data enabled the meteorologist to provide quantitative height assignments to the wind estimates through the translation of cloud temperatures into pressure altitude values.

4. TODAY'S SYSTEM FOR WINDS' PROCESSING

Low level wind estimates are provided by automated procedures using the IBM 360/195 computer system. High level wind estimates are produced by manual procedures augmented by mini-computer capabilities and the IBM 360/195 computer. In addition, manual procedures provide the final quality control of the high and low level wind fields. Wind estimates are derived for 00Z, 12Z and 18Z synoptic times using infrared data (4x8 km resolution) from the SMS-2 and GOES-1 satellites with geographical coverage from 177.5°E to 25.0°W longitude and 45°N to 45°S latitude. A generalized flow diagram of the Winds' Processing System is shown in figure 1.

4.1 AUTOMATED PROCEDURES

There are three basic components comprising the automated operation - Pre-Processing, Picture Pair Processing and Winds Editing.

4.1.1 PRE-PROCESSING. For each operation (00Z, 12Z and 18Z), a sequence of four pictures (30 minutes apart) are ingested from both GOES-1 and SMS-2 and acquired on magnetic tape. Although only two pictures per spacecraft are used for Winds' processing, four pictures are acquired to provide backup pictures in the event one or both of the pictures normally used are of poor quality. Each picture is pre-processed on the IBM 360/195 immediately after ingest. The pre-processing function provides for the quality control of the data (detection of format anomalies, scan line dropout, etc.), the transfer of data from magnetic tape to disk, and the computation of earth centering coordinates required for earth location.

4.1.2 PICTURE PAIR PROCESSING. This segment of the processing is comprised of three vital components - Data Evaluation, Landmark Registration and Cloud Target Selection and Measurement.

4.1.1.1 DATA EVALUATION. With the completion of the pre-processing, a four picture data base resides on disk for each satellite providing five possible picture pair candidates (having time intervals of 30 or 60 minutes) for processing. Diagnostic information from the pre-processing segment is used to evaluate the data quality of each picture. Consideration is given to the rapid life cycle (growth and decay) of clouds with greater weight given to picture pairs having 30 minute intervals. Also, greater weight is given to the pair nearest the synoptic analysis time (00Z, 12Z and 18Z). A merit score for each pair is determined considering the above factors and the pair with the highest merit score is selected for processing.

4.1.1.2 LANDMARK REGISTRATION. Precise registration of the two picture images is required to measure cloud motions accurately. Investigation has shown that the misregistration of earth located landmarks common to both pictures is a result of a translation error and therefore constant. The Landmark Registration procedure applies cross correlation to landmarks common to both pictures to determine the correction necessary to align the two pictures (Green et. al. 1975). A 32x16 array, centered on a predefined landmark latitude longitude point, is extracted from picture "A"; and a companion 64x32 array, centered on the same point, is extracted from picture "B". Cross correlations are computed for all possible positions of the smaller array within the larger array. These positions are identified by their vertical and horizontal lag values; which range from -8 to +8 in the vertical and -16 to +16 in the horizontal. The displacement of the maximum correlation, relative to the center of the 33x17 array of correlations, is the displacement of the target. This procedure is applied to as many as eighty landmarks and the target displacements are stored in the computer. Since cloud-free landmarks have the same displacement, the stored values are examined for consistency and the registration correction is determined. Cloud covered landmarks display spurious displacements resulting from the motion of the clouds over the 30 or 60 minute time interval.

4.1.1.3 CLOUD TARGET SELECTION AND MEASUREMENT. Potential low level targets are defined at pre-selected 2½ latitude longitude locations. A 32x16 array centered on a pre-selected latitude longitude location is extracted from Picture "A" and examined with regards to being a potential low level cloud target. The low level temperature range used in this examination is determined

(for each latitude longitude location) from conventional 700 mb and 1000 mb temperature analyses. If 30% or more of the array values fall within the low level temperature range, the target is accepted as being valid for displacement measurement. If the array examined does not meet this requirement, it is rejected from consideration and the next potential target is extracted and examined.

Once the target has passed the selection criteria, a 64x32 array centered on the same latitude longitude location is extracted from Picture "B" (the later picture). The cloud motion displacement is determined using a refinement of the basic cross correlation algorithm, called temperature slicing, which is applied to the 32x16 target array and companion 64x32 search area array. In this approach, the temperatures contributing to the coefficients obtained from the correlation of the target area and companion search area are only those which fall within the low level temperature range. This is accomplished by nullifying the contribution made by the temperatures which exceed the range.

In the normal situation, the determination of the cloud motion displacement would require the computation of $33 \times 17 = 561$ correlation coefficients. To minimize the number of computations required, the First Guess/Fast Displacement Algorithm was developed. This technique uses a first guess (850 mb wind from the latest analysis) and pre-defined allowable deviation from the first guess to define an optimal search A in the cross correlation matrix. Coefficients are computed for area A' which is slightly larger than the optimal search area A. The areas A' and A may be thought of as two concentric rectangles. If the maximum coefficient is found in area A, it is assumed to be the maximum coefficient of the entire cross correlation matrix. However, if the maximum (value) is not found in A, coefficients are computed for all of the 561 lag value positions which are then scanned for the maximum (value). At the completion of this process, the cloud motion displacement obtained from the correlation matrix is translated into an earth located wind estimate (expressed in meteorological notation).

The computation of image coordinates (scan line and sample), given a latitude longitude, is accomplished by a variation of the approach used in the image mapping and gridding of GOES data (Ellickson, 1975 and Shellman and Dolittle, 1975).

4.1.3 WINDS EDITING. At this stage, the computation of the low level wind field has been completed and the automated editing procedures are applied. First, obvious erroneous wind estimates are removed when the absolute speed difference between the wind estimate in question and the 850 mb wind exceeds 15 mps. Second, the remaining wind estimates undergo three independent quality tests based upon the analysis of cross correlation parameters and the deviation of the wind estimates in question with the 850 mb analysis and adjacent neighbor wind estimates. Depending upon the results of the tests, each wind estimate is assigned a Quality Index (QI) or rejected. The QI is defined as the percent probability that a meteorologist would accept the given wind estimate as being meteorologically sound. At the end of this process, the quality controlled wind estimates are stored in the IBM 360/195 computer and a facsimile mercator map containing the wind field is prepared and presented to the meteorologist for his evaluation.

4.2 MANUAL PROCEDURES

The components of the winds system providing for the manual procedures are - Loop Movie Generation, Target Selection and Measurement, Target Temperature Determination and Wind Computation (Young, 1975).

4.2.1 LOOP MOVIE GENERATION. Infrared picture data of 8 km resolution are acquired on film recorder. After photographic processing, the pictures are manually registered and a loop movie is made consisting of five picture images taken over a 2 hour time span.

4.2.2 TARGET SELECTION AND MEASUREMENT. An overhead movie projector is used to display the film loop on a paper worksheet placed on a plotting board. The meteorologist studies the projected animation and selects the appropriate high level targets. The analyst measures cloud displacement by pencil marking the initial and final position of the cloud target with the direction of flow

indicated by an arrow. After the target displacement measurements have been obtained, the analyst derives the temperature for each target.

4.2.3 TARGET TEMPERATURE DETERMINATION. The analyst is assisted in his determination of cloud target temperature through the use of the Man-Machine Interactive Processing System (MMIPS) (Bradford et. al. 1975). The MMIPS enables the analyst to display the satellite observed cloud target temperature in gray scale and numerical format. In addition, the MMIPS computes and displays a standard frequency distribution for a 17x17 array of cloud target temperatures and provides corrected cloud target temperatures based upon different emissivity values. The corrected cloud target temperature is determined using the digital infrared data corresponding to the middle picture of the film loop. Once the data have been loaded into the MMIPS, the analyst can display the target used for the displacement measurement. From the frequency distribution, the analyst determines the temperature of the coldest cluster of satellite observed target values (B_T). From the loop movies, the analyst estimates the emissivity (E), defined as the radiating efficiency of a blackbody. For E=1, B_T is accepted as the target temperature. For E=0.75, 0.85 and 0.95, a corrected target temperature (B_C) is computed using the following equation: $B_C = (B_T - B_S(1-E))/E$ where B_S is the satellite observed background temperature. For E<0.75, the meteorologist will omit the cloud target from consideration or assign the cloud motion vector to a pressure level he determines as appropriate based upon his knowledge of the synoptic situation. Target temperatures are recorded on the worksheet with their corresponding vector end points.

4.2.4 WIND COMPUTATION. The translation of the vector end points into wind estimates and the translation of the MMIPS derived temperatures into specific pressure altitudes are accomplished by computer procedures. The vector end point information and the corresponding temperatures on the worksheet are recorded on punch cards through the use of a "Datagrid Digitizer" which is connected to a card punch. The vector end point information on punch cards is then submitted to the IBM 360/195 for processing.

The computer processing involves the translation of the vector end point information in digitized x,y coordinate format to earth located cloud motion vectors. Once the vector has been earth located, the MMIPS derived temperature is referenced to the latest analyzed vertical temperature profile (provided by the National Meteorological Center) at that location to determine the pressure altitude.

4.3 FINAL QUALITY CONTROL/MANUAL EDITING

Manual analysis techniques provide the final quality control of the wind estimates produced by the automated and manual procedures. The facsimile display containing the low level wind estimates is carefully inspected by the meteorologist. He transcribes the latest surface pressure field, frontal systems and high level cloud pattern to the facsimile display. In complex situations, he may refer to the loop movie. To be acceptable, each low level vector must be in approximate agreement with the geostrophic flow derived from the previous six hourly surface chart and the two hour loop movie. Since each low level estimate has a unique identifier, the rejected estimates are readily purged from the computer disk file. The high level wind estimates are quality controlled in a similar manner using the latest 500 mb and 300 mb analysis. The edited wind estimates are then moved to the disk product file where they can be accessed by the National Meteorological Center for use as input to all Analysis and Production Models. The product vectors are also reformatted by computer into an observation code form for teletype transmission to world-wide users. High and low wind estimates from a typical operation are shown in figure 2.

4.4 SUMMARY - TODAY'S SYSTEM

Currently, NESS provides approximately 600 Wind estimates per analysis cycle or 1800 per day compared to approximately 300 per day for the yesterday's winds' processing system. The user community receiving these data has expanded from a very limited number of domestic users in the late 1960's and early 1970's to well over twenty domestic as well as foreign users at the present time.

Prior to August 1974, when winds analysts used only visible imagery for cirrus level cloud motion analysis, all tracers were arbitrarily assigned to the 300 mb level in the extratropics and the 200 mb level in the tropics. Vector deviations of these high level wind estimates from co-located rawinsonde winds are depicted by the solid line on figure 3. Since the advent of IR SMS/GOES imagery and the subsequent use of the MMIPS derived temperature and pressure altitude values, these deviations from rawinsonde reports (at the assigned level) have been reduced significantly. The position of the dashed line in figure 3, indicates approximately 10% reduction in the magnitude of these deviations.

5. TOMORROW'S (1978-1980) PROCESSING SYSTEM

Figure 4 portrays the evolution of the processing system for winds that is planned for operation in 1978.

5.1 DIRECT INGEST SYSTEM AND GOES DATA BASE: (1) IN FIGURE 4

A hardware/software system that will acquire data from the satellites and then transmit data directly to the IBM 3330 disk drives for direct access via the IBM 360/195 system is currently under development. This "Direct INGEST SYSTEM" will eliminate today's manual tape handling system. Once the raw VISSR data are available to the IBM 360/195, a software system will extract "sectors" of the data, which represent about 100-degrees longitude by 100-degrees latitude centered at the subpoint of each satellite. These sectors will be preprocessed into a "GOES Data Base" that is time oriented, earth located, calibrated and formatted for multiple applications. This step replaces the preprocessing now done for the P/P software and further replaces the photographic process needed to prepare the movie loop for projection onto the digital data grid. It is anticipated that a full 24 hours of 8-km resolution, infrared sectors from each satellite can be stored in the data base.

5.2 WINDS' INTERACTIVE PROCESSING SYSTEM (WIP): (2) IN FIGURE 4

This hardware and software system uses the analysis functions of the MMIPS to replace the photographic movie loops, the digitizer board (data grid), and the card-punch system of entering vector-end point and temperature data into the IBM 360/195 system. An analyst at the MMIPS console can call for a sequence of images from the GOES data base, display those images in the cine-motion on a high-resolution TV screen, and designate the beginning and ending points of cloud tracers, and calculate temperature-height relationships (DOSS). This interactive system automatically supplies cloud-tracer-end-point data to the vector calculation program (LUPWND II) ("4" in figure 4) in the IBM 360/195. A paging and recording system on a cathode ray tube (CRT) display allows the analyst to review his work prior to submitting the data to the large computer. This CRT system with its keyboard provides the interactive functions for the analyst.

5.3 VECTOR EDITING (VET): (3) IN FIGURE 4

The manual procedures of plotting cloud motion vectors on conventional weather maps, punching deletions on cards, comparing different images to various map projections by eye, etc., are to be replaced by the interactive system called VET. Data and analysis fields from the NMC's data sets that are resident on the IBM 360/195 computer are accessed and presented to the analyst on the TV screen of the MMIPS station. The outputs of both LUPWND II (the manually derived vectors from WIP) and P/P (the automated low-level vector system) can be superimposed and mixed with image data and analysis fields under analyst control. Various graphical and color-display modes are possible along with a variety of map scales, sector enlargements, and map projections that are selectable by the analyst. Vector values can be corrected and keyed directly into the IBM 360/195 system without going through the punched card system currently in use. It has been estimated that this interactive editing system, compared to the current processing system, will save approximately one hour of processing time.

6. A SCENARIO OF OPERATIONS IN 1978

6.1 TODAY'S OPERATIONAL SCHEDULE

Figure 5a (Today's System) depicts today's processing system as a function of time for the 1200Z synoptic analysis cycle. This procedure is duplicated for the 0000Z and 1800Z analysis cycles. The left column depicts the sequence of automated events. The center column shows the only current operational application of the MMIPS for winds' processing. The right column presents the manual movie-loop system. "LFM model" refers to the limited fine mesh model of the NMC, which provides basic forecast guidance for the continental United States. "PE model" refers to the analysis cycle of the NMC global primitive equation prediction model.

6.2 TOMORROW'S OPERATIONAL SCHEDULE

Figure 5b (Tomorrow's System) is a possible schedule for the implementation of the processing capabilities described in this paper. Note that much of the manual portions of the processing are to be done via the MMIPS. There are no film movie loops, and there is to be a close interaction between the analyst and the large computer system. Being relieved from many tedious, manual chores the meteorologist/analyst will be able to devote more attention to the careful selection of cloud-motion targets, the careful tracking of the targets, and the quality control of his work. The automation of process and calculations leads to increased efficiency, faster delivery of data, and greater reliability of production. This system will provide the capabilities to produce a large quantity of high-quality wind data for the FGGE data sets.

REFERENCES

- Bradford, R.E., Leese, J.A., and Novak, C., 1972: "An Experimental Model for the Automated Detection, Measurement and Quality Control of Low-Level Cloud Motion Vectors From Geosynchronous Satellite Data," Proceedings of the Eight International Symposium on Remote Sensing of Environment, Environmental Research Institute of Michigan, Ann Arbor, Mich., 2-6 Oct. 1972, pp 441-462.
- Bradford, R.E., Waltham, W.B., and Kazmierczak, M.M., 1975: "The Man-Machine Interactive Processing System," NOAA Technical Memorandum NESS-64, NOAA, pp 83-93.
- Bristor, C.L., Frankel, M., and Kendall, E., 1967: "Some Advances in Automatic Determination of Cloud Motion and Growth from Digitized ATS-1 Picture Pairs," Unpublished Manuscript.
- Ellickson, J., 1975: "Earth Locator Grids for VISSR Images," NOAA Technical Memorandum NESS-64, NOAA, pp 37-43.
- Green et. al., 1975: "The Automatic Extraction of Wind Estimates from VISSR Data," NOAA Technical Memorandum NESS-64, NOAA, pp 94-110.
- Hubert, L.F., and Whitney, Jr., L.F., 1971: "Wind Estimation from Geostationary Satellite Pictures," Monthly Weather Review, Vol. 99, No. 9, Sept. 1971, pp 665-672.
- Leese, J.A. et.al., 1970: "The Determination of Cloud Pattern Motions from Geostationary Satellite Image Data," Pattern Recognition, Pergamon Press, Vol. 2, pp 279-292.
- Shellman, M., and Doolittle R.C., 1975: "Operational Mapping of VISSR Imagery," NOAA Technical Memorandum NESS-64, NOAA, pp 44-47.
- Young, M.T., et. al., 1972: "Operational Procedures for Estimating Wind Vectors from Geostationary Satellite Data," NOAA Technical Memorandum NESS-39, NOAA, 19pp.
- Young, M.T., 1975: "The GOES Wind Operation," NOAA Technical Memorandum NESS-64, NOAA, pp 111-121.

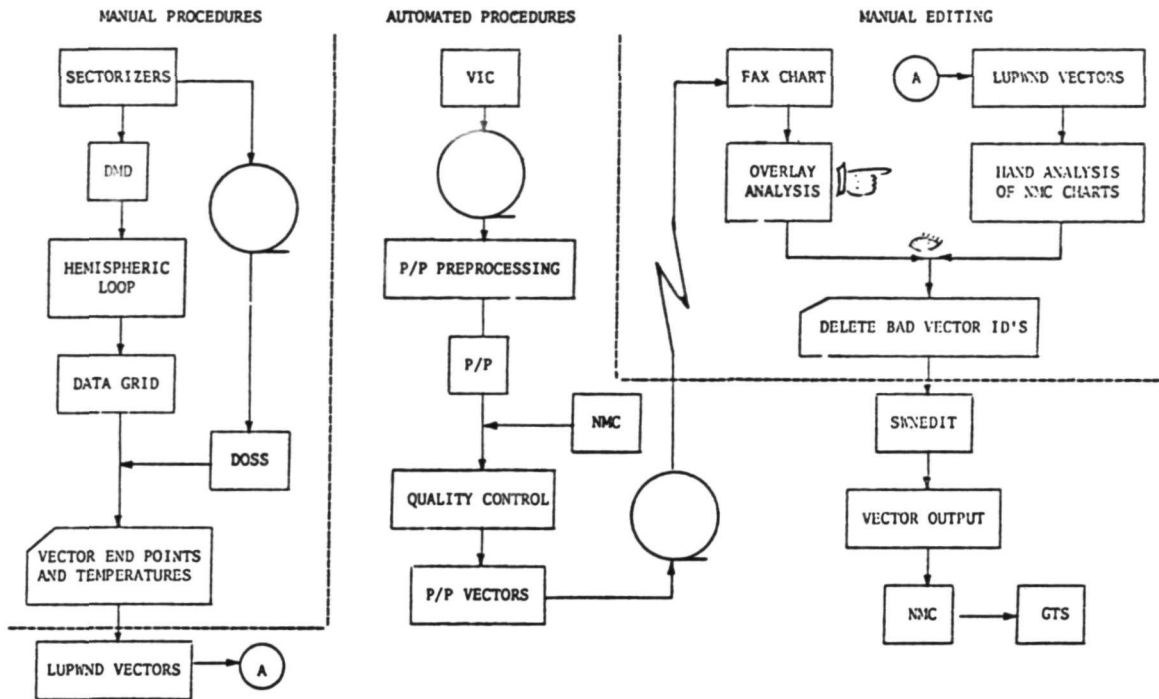

VIC: VISSR Ingest Computer
 DND: Photographic Device
 P/P: Picture-Pair Software
 DOSS: Temperature Height Estimating System

FIGURE 1. TODAY'S PROCESSING SYSTEM

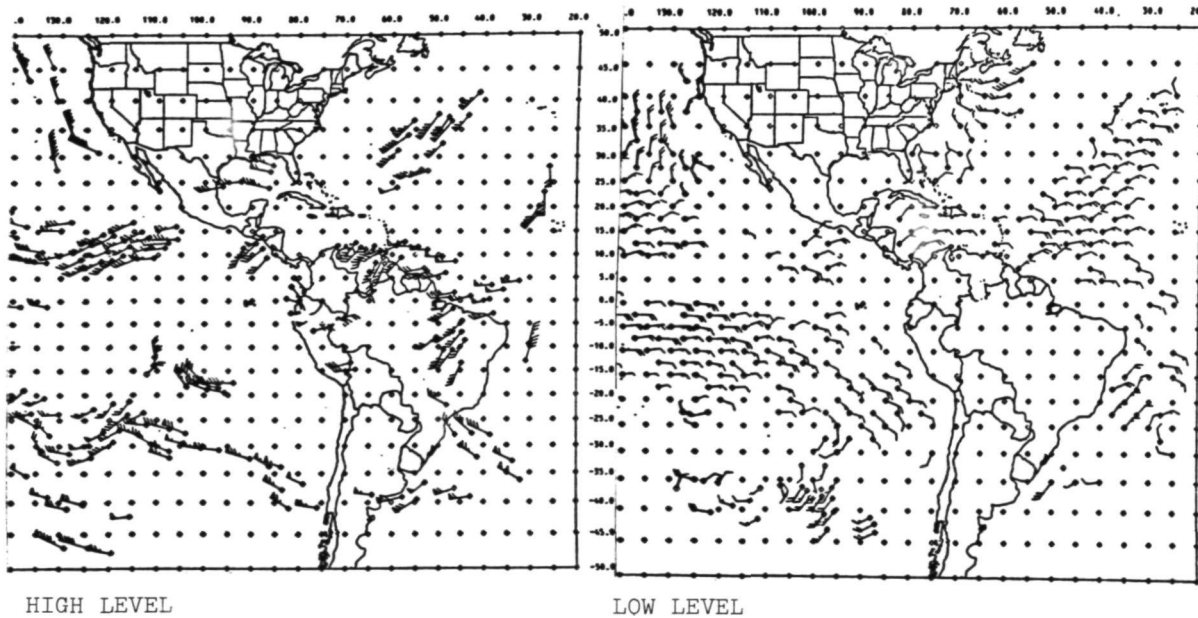

FIGURE 2. HIGH AND LOW LEVEL WIND ESTIMATES, 1000Z, APRIL 13, 1976

ORIGINAL PAGE IS
 OF POOR QUALITY

ORIGINAL PAGE IS
OF POOR QUALITY

SATELLITE DERIVED WIND VECTORS AS COMPARED TO RAWINSOONDE DATA

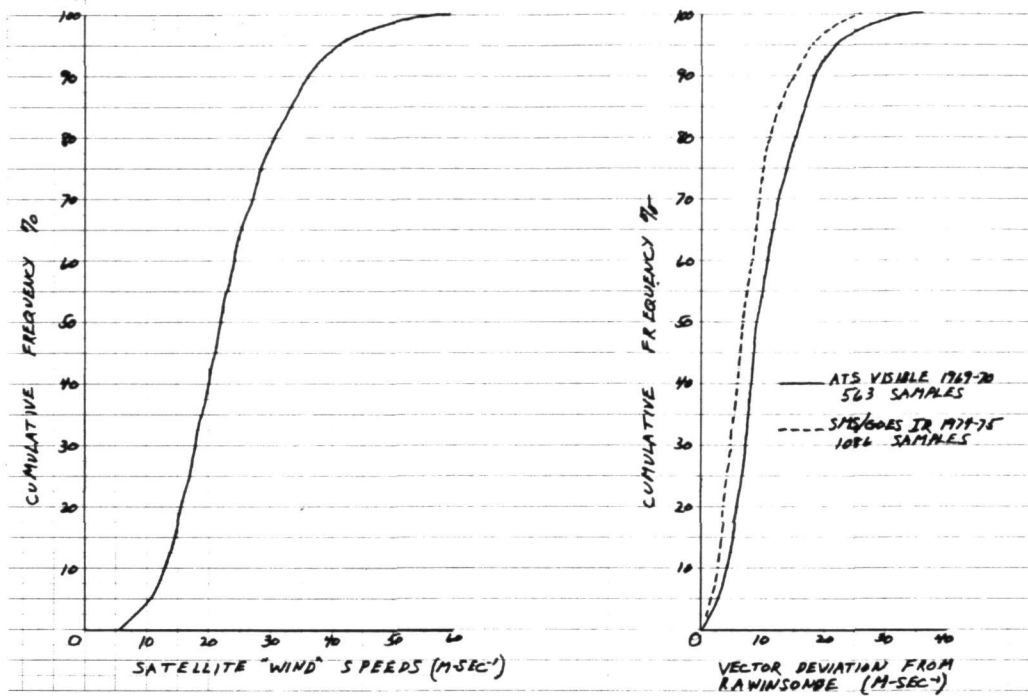

FIGURE 3. VERIFICATION COMPARISONS

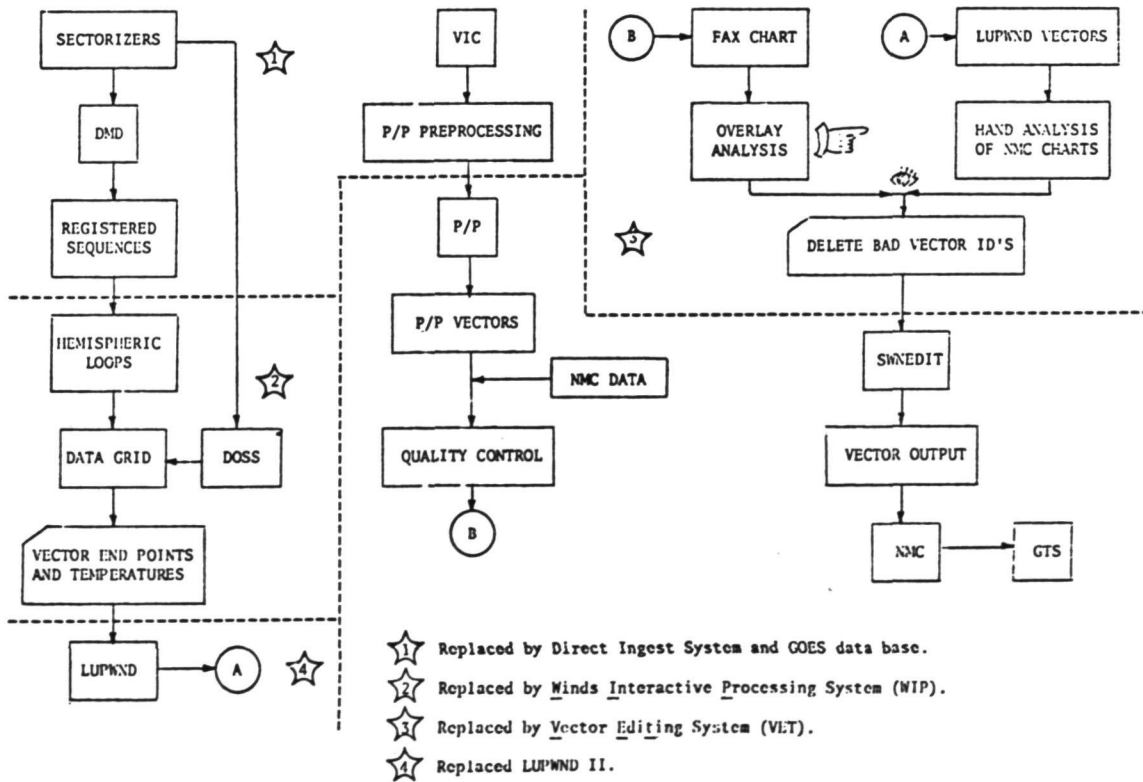

FIGURE 4. EVOLUTION OF TOMORROW'S PROCESSING SYSTEM

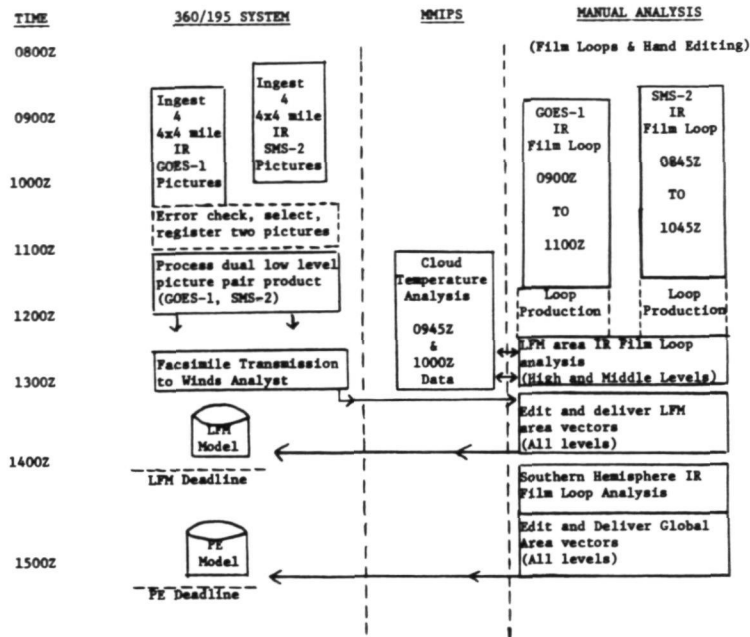

FIGURE 5a. TIME FLOW - TODAY'S SYSTEM

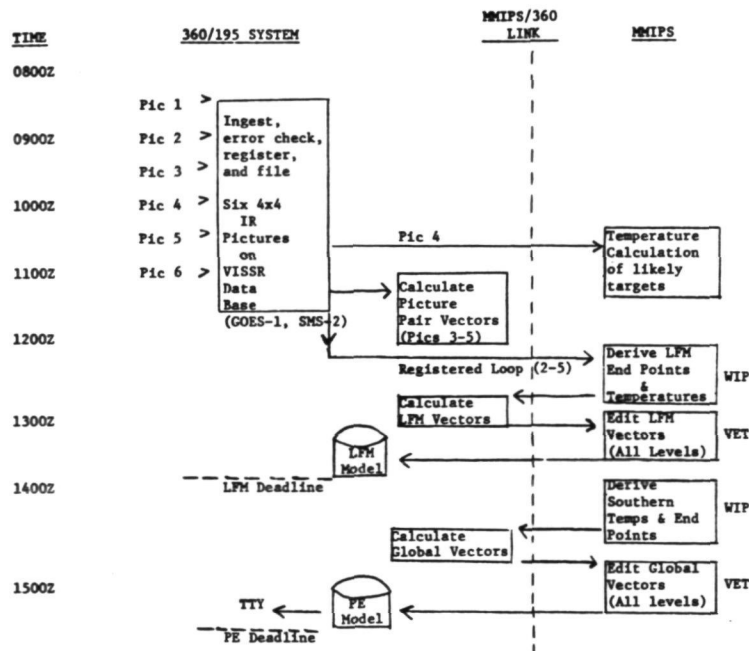

FIGURE 5b. TIME FLOW - TOMORROW'S SYSTEM