

N78

19029

UNCLAS

N78-19029

MAGNETOMETER DEPLOYMENT MECHANISM FOR PIONEER VENUS*

By William L. Townsend
Hughes Aircraft Company

ABSTRACT

A three segment, 15-foot boom mechanism was developed to deploy magnetometers from the Pioneer Venus orbiter spinning shelf. The stowage mechanism is designed to contain the magnetometers during launch and to deploy these instruments by centrifugal force upon pyrotechnic release. Unique graphite-epoxy boom segments are used for a lightweight design with sufficient strength to withstand a 7.5 g orbit insertion force while extended. The detailed design is described along with the test methods developed for qualification in a one-g field.

INTRODUCTION

The Pioneer Venus 1978 mission includes magnetometers on the spinning orbiter, Figure 1, to map the magnetic fields around Venus. These measurements require a 15-foot separation from the edge of the spinning shelf in order to minimize spacecraft magnetic effects. A 2-axis magnetometer is placed at the 15-foot position, and a single axis magnetometer is located at a 10-foot position for a magnetic gradient measurement.

The Magnetometer Deployment Mechanism (MDM) supports the magnetometers in a three-segment folded condition for launch, spacecraft separation and spin-up. The mechanism is pyrotechnically released to deploy the magnetometers approximately four hours after launch. Figure 2 shows the MDM in a partially deployed position. Early deployment is necessary for mass balance of the spinning shelf and to permit magnetometer calibration while still in the known magnetic field of the earth. The MDM reliability must be emphasized since failure to deploy will leave the spacecraft with a wobble angle unacceptable to most of the scientific instruments.

When the spacecraft arrives at Venus, a 7.5 g orbit insertion maneuver is required while the MDM is locked in the extended position. In addition, the spin stabilization during orbit insertion requires that the MDM deflection be limited so that spacecraft wobble angles are not excessive. This combination of strength and deflection requirements dictates a boom designed mainly for stiffness rather than material strength.

Once the spacecraft is in Venus orbit, the MDM must maintain magnetometer axes alignment within 1° of the prelaunch condition. The error must be allocated to include thermally induced distortion, latch repeatability, initial alignment uncertainty and elastic deformation due to centrifugal forces.

* This work was conducted under NASA contract NAS 2-8300

DESIGN REQUIREMENTS

The mission profile places design requirements for the Magnetometer Deployment Mechanism (MDM) into the following four distinct modes. Values are listed in Table 1.

1) Launch - The MDM must be folded and stowed to fit on the edge of the spacecraft shelf and to be within the 111 inch shroud diameter. The stowage system must limit launch accelerations on the magnetometer instruments to 22.5 g's.

2) Deployment - The MDM stowage mechanism must be designed with redundant pyrotechnic release for reliability. The MDM must be centrifugally deployed from the shelf while spinning at approximately 6 rpm. The mechanism must be designed with high reliability to latch after extension and with sufficient strength margin to absorb excess latching energy.

3) Orbit Insertion - The extended MDM must withstand 150% of the 7.5 g orbit insertion forces without damage and must be stiff enough to limit tip deflection to 10.5 inches when subjected to 7.5 g force.

4) Orbit Operation - The MDM must be designed using magnetically clean materials to limit magnetic effects to 0.04 gamma at the tip. The magnetometer alignment must remain within 1° of initial installation.

TABLE 1
REQUIREMENTS SUMMARY

Launch Mode (Stowed)		
Sine Vibration Thrust	5 to 2000 Hz	11.5 g Max.
Lateral	5 to 2000 Hz	5.5 g Max.
Random Vibration	20 to 2000 Hz	11.5 g - RMS
Natural Frequency		> 4.0 Hz
Magnetometer Max. Acceleration		< 22.5 g's
Deployment Mode		
Spin Speed		6.0 to 7.0 rpm
Release		Redundant pyrotechnic devices
Deployment Shock		< 8 g's
Temperature		0° to 100°F
Orbit Insertion (Deployed)		
Spin Speed		30 rpm
Insertion Acceleration (⊥ to boom ∩)		7.5 g's (11.25 g design)
Natural Frequency		> 1.0 Hz
Deflection Maximum		10.5 inches at tip
Temperature		+100°F to +150°F
Orbital Operation (Deployed)		
Spin Speed		up to 65 rpm
Magnetics		< 0.04 gamma
Temperature		-200°F to +150°F
Mechanism Boom Length		> 15.7 ft
Alignment Accuracy		± 1.0 degree
Weight Deployable Portion		10.36 lbs
Non-Deployable Portion		<u>6.08 lbs</u>
Total		16.44 lbs

In addition to the mission requirements, a ground test requirement was imposed to permit deployment demonstration during system test. Although the ground test imposes gravity induced frictional forces and aerodynamic forces not encountered in orbit, it does provide a set of data for analytical comparison to orbital conditions.

BOOM DESIGN

As can be seen on Figure 3, the boom segments are tapered tubular members for lightness, high stiffness and strength. The design loads including the 50% margin above 7.5 g orbit insertion mode are as follows.

a) Inboard Hinge	892 ft-lb
b) Center Hinge	380 ft-lb
c) Outboard Hinge	94 ft-lb

In addition to orbit insertion loads, the boom segments must be designed to absorb the residual energy for the worst case latching condition. For example, the middle segment must absorb 7 foot-pounds of excess energy. There is also a torsional strength requirement because of mass asymmetry of the hinges and magnetometers.

Graphite-epoxy material was selected for the boom segments because of its low density, high modulus of elasticity, magnetic cleanliness and ease of fabrication in a tapered tubular form. Beryllium was seriously considered but could not be easily obtained with sufficient magnetic cleanliness. Fiberglass-epoxy and aluminum tubing have structural properties significantly inferior to those of graphite-epoxy. The extent of the taper is dramatic with a 4.125 inch diameter at the root and 1.5 inch diameter at the tip. The tube ends are reinforced by bonding into the sockets of the titanium hinge fittings. Intermediate load points are reinforced by fiberglass bulkheads bonded inside the segments and fiberglass rings bonded outside the segments.

HINGE AND LATCH DESIGN

The engineering model hinge and latch are shown on Figure 4. The hinge pin, a beryllium copper cylinder, forms a journal bearing with the 6AL-4V titanium hinges. Redundant journals are provided by a sliding fit on each hinge half. There are redundant beryllium copper locking pins spring loaded against the titanium semi-circular tracks. The half-hinge and track are machined from one 6AL-4V titanium piece. In order to meet redundancy requirements, each locking pin has sufficient strength to withstand all loading conditions.

The preloaded locking pins have the disadvantage of friction drag along the tracks throughout deployment. On the other hand, this design insures that the pins remain cocked until the proper latch position is reached. The drag friction torque is constant throughout deployment and is predictable using phenolic bonded MoS₂ dry lubrication. Wear during ground test was shown to be of little concern since an excess of 100 deployment cycles caused no significant change in friction torque.

The locking pin is designed with a tip radius to ride on the track, with a lead-in tapered section, and with a final cylindrical section to absorb stopping forces without being driven back out of engagement. The tapered section provides a 4 degree pull-in range to encompass a possible offset angle should the hinge stop rotating prior to full closure. When the locking pin is fully engaged, it is spring preloaded into a tapered socket for a repeatable latch position. Latch reliability is also enhanced by using a preload to impart locking pin acceleration of 50 to 100 g's. Even in the highest conceivable hinge closing rate of 300 degrees/second, the locking pin fully seats prior to overshooting the socket centerline.

The hinge shown on Figure 4 is typical of the middle and outer hinge designs. The root hinge as seen in Figure 3 has a cantilevered hinge pin to be compatible with the shelf structural load path. The locking pins are designed as described above except the latching action is parallel to the hinge.

ELECTRICAL CABLE DESIGN

The electrical cable is a special design for this application to achieve specific electrical performance for low level signals and to achieve low repeatable bending torque over the deployment temperature range of 0° to 100°F.

The conductor complement to meet the magnetometer excitation and signal feed-back requirements is listed below. The cable bending torques were measured to be as high as 18 in-oz at low temperature and less than 1 in-oz at high temperature. Silicone encapsulation is molded around the conductors to form the necessary flat cross-section. In order to save weight, the silicone encapsulation provides the necessary insulation resistance for the single conductors and braided shields without separate teflon jackets.

	<u>Quantity</u>	<u>Type</u>
Electrical Cable Conductors	3	Twisted-Shielded Pairs
	2	Twisted-Pairs
	6	Shielded Singles
	2	Singles

MDM STOWAGE SYSTEM

The MDM is folded for launch in the manner shown on Figure 2. The three segments are supported by two cradles placed close to the mass concentrations of the hinges. Both cradles have hinged segments that are released by redundant pyrotechnic pin pullers. The outboard cradle (more distant from the root hinge) contains a spring-loaded plunger to push the three segments clear of the cradle despite any misalignment forces induced by distortion. The plunger also breaks lose any static friction in the cradle linkage to insure a predictable deployment sequence. The cradle linkage and plunger are shown on Figure 5.

The cradle structure is made of aluminum with MoS₂ dry lubrication on the hinge pins. Two links are hinged and contain torsion springs for deployment to provide redundant mechanisms for clearing the path for boom motion. Each boom segment has fiberglass support spacers to contact the aluminum cradle structure. These spacers are bonded to the boom segments so that the aluminum support brackets provide a clean unobstructed track-like surface for the different shapes that must pass during deployment.

Since both cradles must be pyrotechnically released for successful MDM deployment, both contain redundant pin pullers to eliminate single point mechanical failures. This redundancy concept is shown on Figure 6. At each cradle both pin pullers are retracted. The intermediate link permits release even if any one of the 2 pins per cradle remains engaged.

DEPLOYMENT SEQUENCE

The deployment sequence was modeled on a nine-degree-of-freedom dynamic simulation to include spacecraft dynamics as well as boom deployment. The hinge and cable friction torques were included with cases to cover a range of coefficient of friction from zero to 0.5. Although the spin speed will be selected for the deployment, the setting tolerance is included in the simulation to combine low friction with high spin speed for maximum residual energy. On the other hand, high friction is combined with low spin speed as a check on latch reliability.

The deployment sequence is displayed in Figure 7. The deployment time is 9.75 seconds for a nominal case from electrical initiation of the squib to full extension. The middle hinge latches first with the outer hinge latching only about 0.1 seconds later. At this point the root hinge actually reverses direction momentarily and then resumes the deployment.

When the root hinge finally latches at 9.75 seconds, the outer hinge receives its maximum bending moment. Table 2 displays an analytical comparison of the levels of energy, bending moment and rates encountered.

TABLE 2
MECHANISM LATCH CHARACTERISTICS IN ORBIT

	<u>High Energy</u>			<u>Low Energy</u>		
	High rpm-Low Friction			Low rpm-High Friction		
	Root Hinge	Middle Hinge	Outer Hinge	Root Hinge	Middle Hinge	Outer Hinge
Order of Lock	3	1	2	2	1	3
Closing Rate (deg./sec.)	22	274	6.9	9.6	104	72
Locking Energy (ft-lb)	0.53	4.78	0.48	0.23	0.73	0.11
Fundamental Freq. (Hz)	3.2	17.0	6.9	3.2	17.4	6.4
Transverse Moment (ft-lb)	165	230	45	105	77	30
Moment Capacity (ft-lb)	234	554	106	234	554	106

TEST VERIFICATION

The MDM has undergone a complete qualification at the unit level in-so-far-as practical without the exact spacecraft interface. The qualification will not be fully complete until the MDM can be integrated with the spacecraft. The two most important aspects are vibration with true spacecraft structural coupling and thermal-vacuum with realistic thermal inputs. However, the following tests are appropriate for unit level design verification. The data will be discussed in regard to only the first three items since the last two are purely survival exposures or a pass-fail criterion.

- 1) Release and deployment in room ambient conditions
- 2) Static loads and deflection
- 3) Alignment repeatability
- 4) Thermal cycling with high and low temperature release
- 5) Workmanship vibration

DEPLOYMENT DEMONSTRATION

Room ambient release and deployment were conducted with a rate controlled spin table to set the proper initial spin speed. Film coverage was used to visually record the latch sequence, and potentiometer readings were recorded from each hinge to verify latching velocity and exact timing. Strain gages were used to record boom strain at each hinge during latch-up to verify actual bending moments resulting from excess latch energy.

Initial testing was planned in room ambient conditions despite the aerodynamic drag and increased friction due to 1 g forces. A simplified math model showed that a slight increase in spin speed over the planned six rpm would provide sufficient energy for a deployment demonstration. However, even at speeds up to 9 rpm in air, the root hinge would not deploy to the latch position. A subsequent more detailed math model verified that most of the initial excess momentum was dissipated at latch of the middle hinge and that aerodynamic drag prevented a continuation of the deployment to the latch position of the root hinge. The test was then repeated in a 40 foot diameter tent filled with helium, 1/7 the density of air. The deployment was successful in helium, and the closure times and rates closely compared with the math model as shown on Table 3. A graphic plot of displacement versus time is shown on Figure 8.

TABLE 3
DEPLOYMENT TEST RESULTS IN 95% He ATMOSPHERE

	9.0 RPM SPIN		7.5 RPM SPIN	
	TEST RESULT	SIMULATION	TEST RESULT	SIMULATION
LATCH TIMES (sec.)				
Root	8.4	7.7	11.1	10.3
Middle	2.4	2.5	3.2	3.3
Outer	2.9	3.0	3.6	4.3
VELOCITY AT LATCH (deg/sec.)				
Root	28	32	13	18
Middle	236	235	140	150
Outer	83	83	50	40
PEAK BENDING MOMENT (ft-lb)				
Root	201	191	132	122
Middle	237	227	131	127
Outer	52	52	16	34

ALIGNMENT REPEATABILITY

Most of the factors contributing to alignment error are small compared to the 1.0 degree requirement and compared to the repeatability of the latch mechanism. The effects of temperature gradient, for instance, are minimized by the low coefficient of expansion of graphite-epoxy. Initial alignment uncertainty is minimized by the use of optical surfaces on the spacecraft, the MDM mounting points and on the magnetometers. These optical references are calibrated on the MDM while suspended with the root hinge fixed to the ceiling. The one-g acting along the axis of the suspended boom approximates the effect of centrifugal force in orbit. This arrangement places an approximate elastic strain on the hinges as in the spinning orbital condition. Three-axis alignment data are then used to align instruments on the spacecraft at a later stage of integration.

Repeatability data were collected while the MDM was vertically suspended to verify the alignment error for this predominant factor. Ten readings were taken in each direction of both lateral axes using an 18-ounce force at the tip prior to each reading. The alignment in the boost direction was the more repeatable with an uncertainty of ± 0.1 inches at the tip. The deployment axis alignment includes the hysteresis of the locking pin engagement which showed a tip repeatability of ± 1.1 inches. Although 1.1 inches at the tip seems excessive, the angular error is only 0.35 degrees of the 1.0 degree error allowed.

STATIC LOADS

Two static load tests were conducted using sand bags for incremental loading at the middle hinge, at the outer hinge and at the tip. Deflection measurements were made at each loading point after each weight was added and after each weight was removed. Strain gages were monitored to verify material stress at each loading condition up to the 9.0 g qualification load. The resulting data after interpolation to the 7.5 g condition are shown on Table 4.

TABLE 4
STATIC LOADS TEST RESULTS

	<u>Middle Hinge</u>	<u>Outer Hinge</u>	<u>Tip</u>
A. Orbit Insertion 7.5 g's Deflection (inches)	1.80	6.77	14.59
	<u>Root Hinge</u>	<u>Middle Hinge</u>	<u>Outer Hinge</u>
B. Deployment Loading Equivalent Hinge Rotation (radians)	0.026	0.052	0.054
Equivalent Moment (ft-lb)	638	270	67
Equivalent Stiffness (ft-lb/rad.)	24,560	5,240	1,240

In the 7.5 g limit load of orbit insertion the tip deflection was 14.59 inches, 38% greater than the design analysis. Although the deflection was greater than planned, the boom met the strength margins according to the strain gage data and the increased wobble of 1.1 degrees during orbit insertion is acceptable.

CONCLUSIONS

The Magnetometer Deployment Boom has been successfully developed to meet the objectives of the Pioneer Venus mission. The development was conducted without benefit of a full development model. Only one of the three hinges was machined from aluminum to verify fits prior to commitment of the titanium flight hardware. Aside from static deflection and deployment in air, the analytical simulations were sufficiently successful to eliminate the need for extensive ground testing. As a low cost approach the only MDM constructed was used for both qualification and flight.

REPRODUCIBILITY OF THE
ORIGINAL PAGE IS POOR

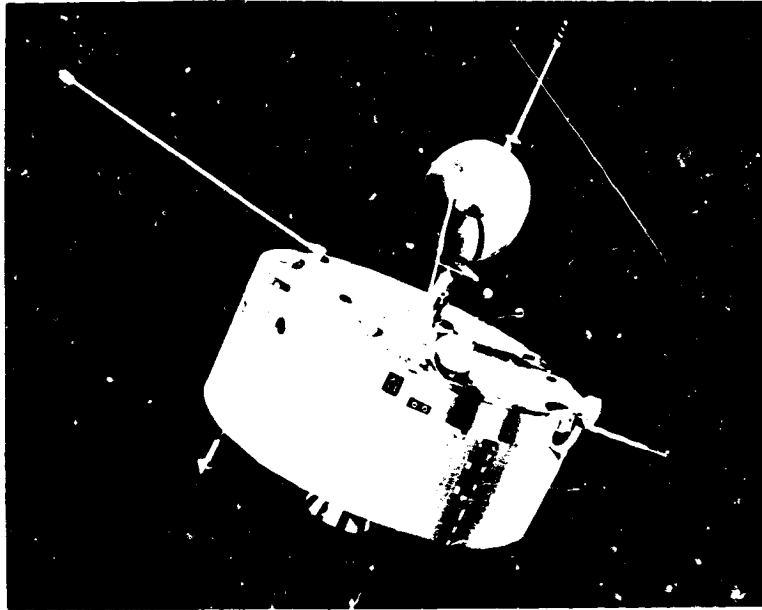

Figure 1. Pioneer Venus
Orbiter

Figure 2. Magnetometer
Deployment Mechanism
with Thermal Control
Finishes

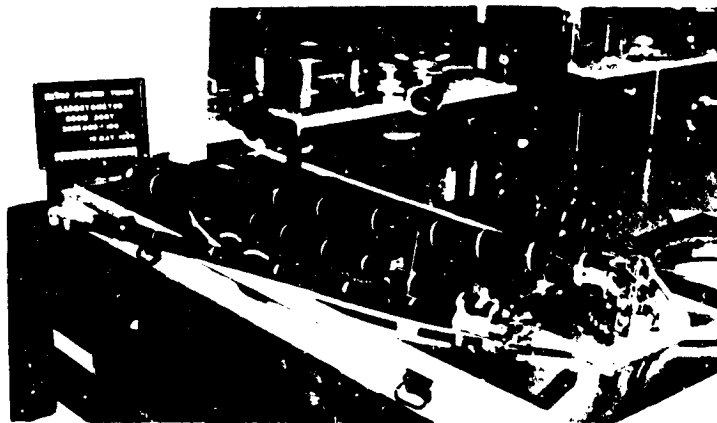
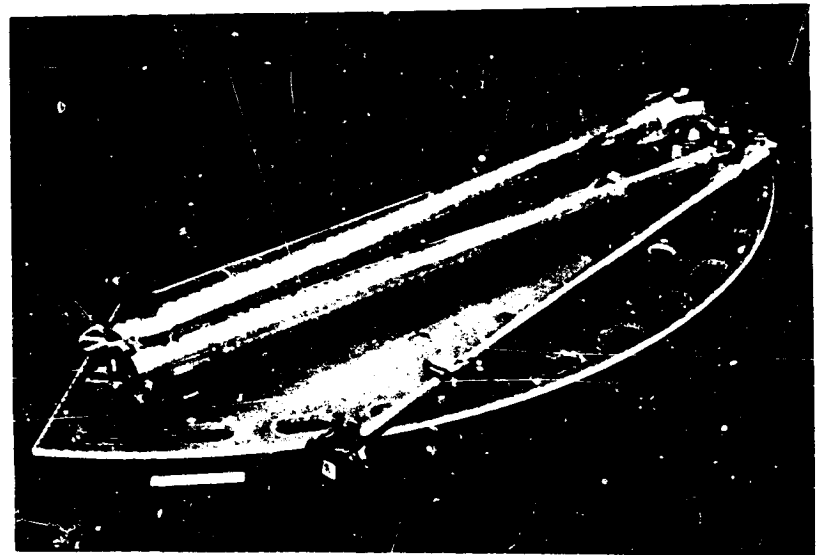

Figure 3. Magnetometer
Deployment Mechanisms
without Thermal Control
Wraps

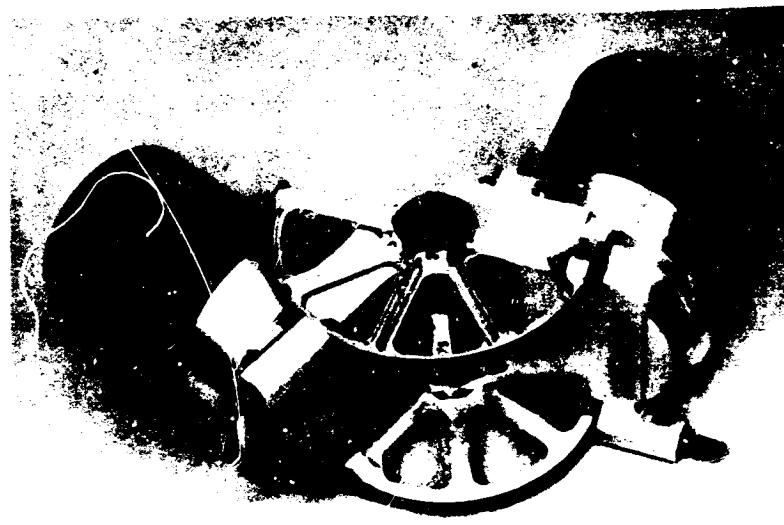

Figure 4. Hinge and Latch Assembly, Engineering Model with Partial Boom Segments

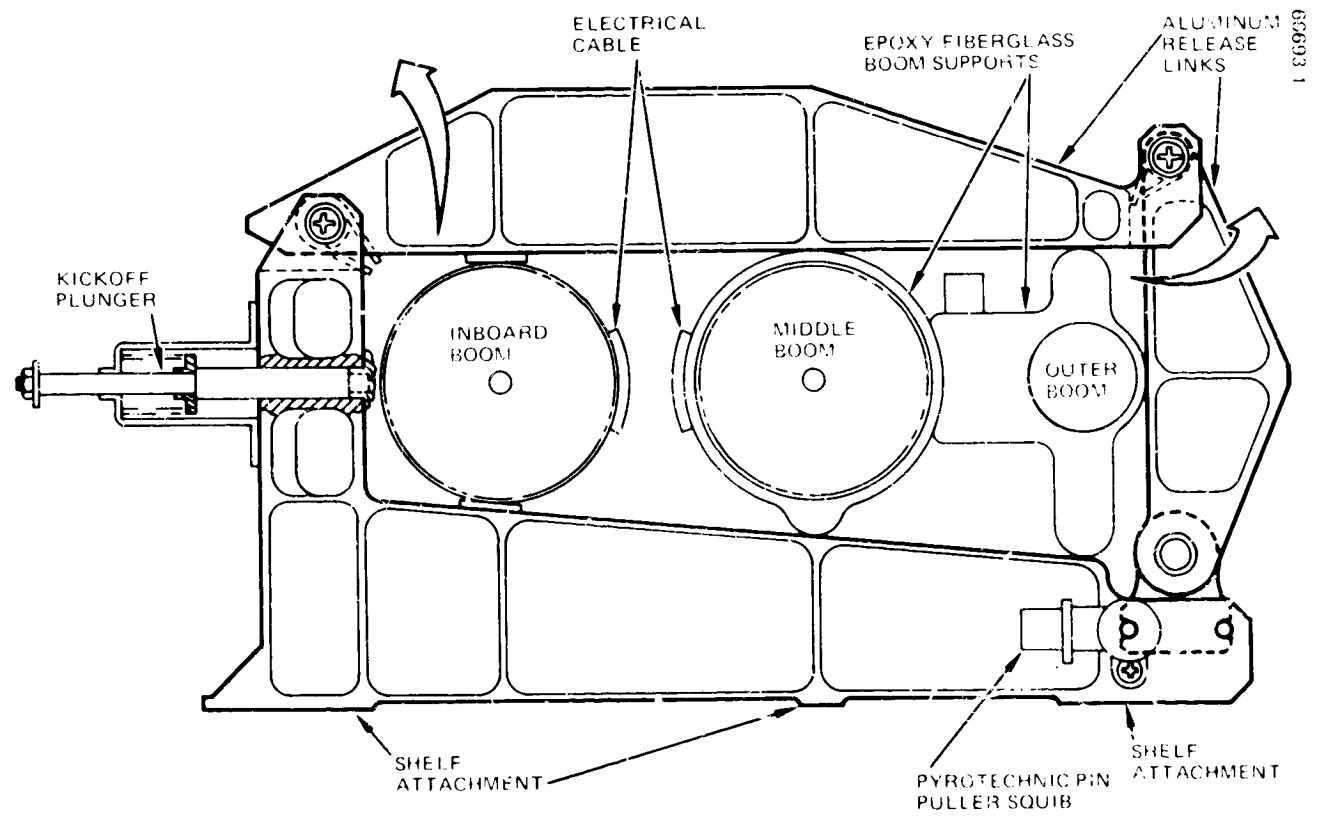

FIGURE 5. OUTBOARD BOOM SUPPORT

66693 2

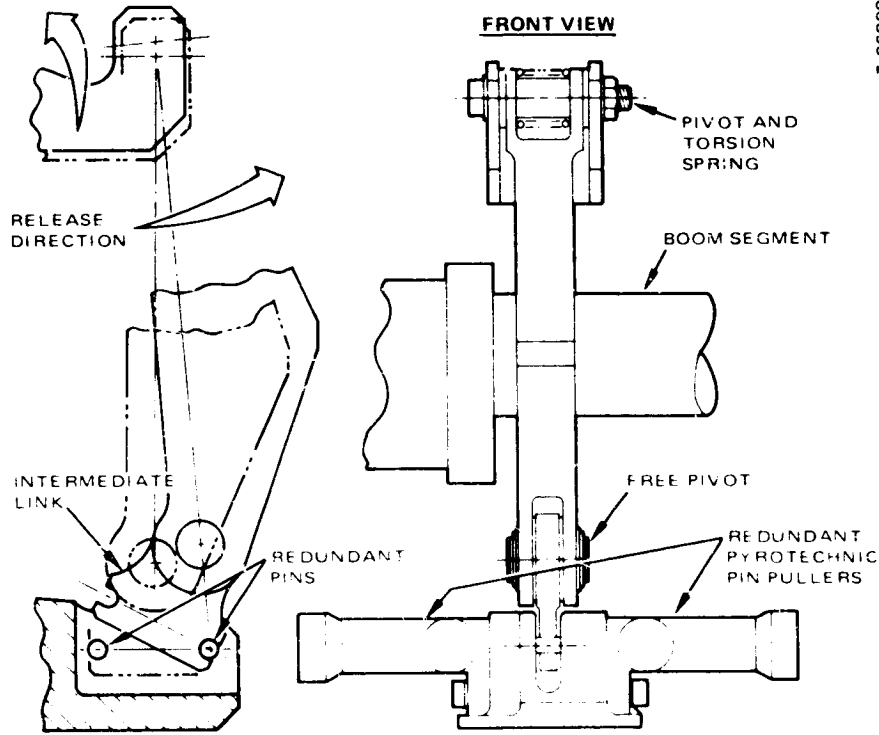

FIGURE 6. REDUNDANT PIN PULLERS

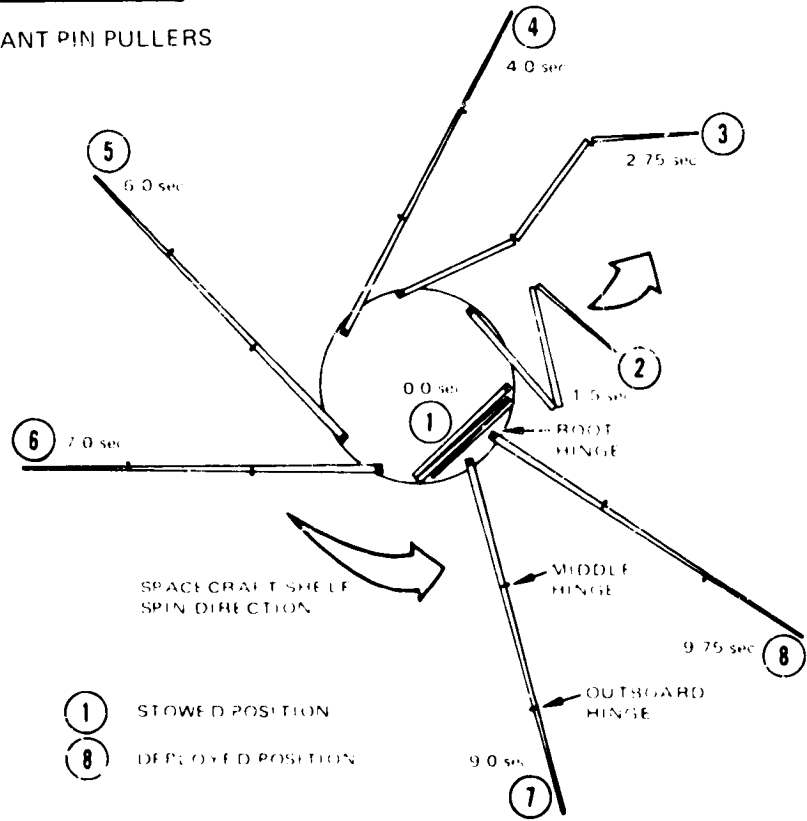

FIGURE 7. TYPICAL DEPLOYMENT SEQUENCE

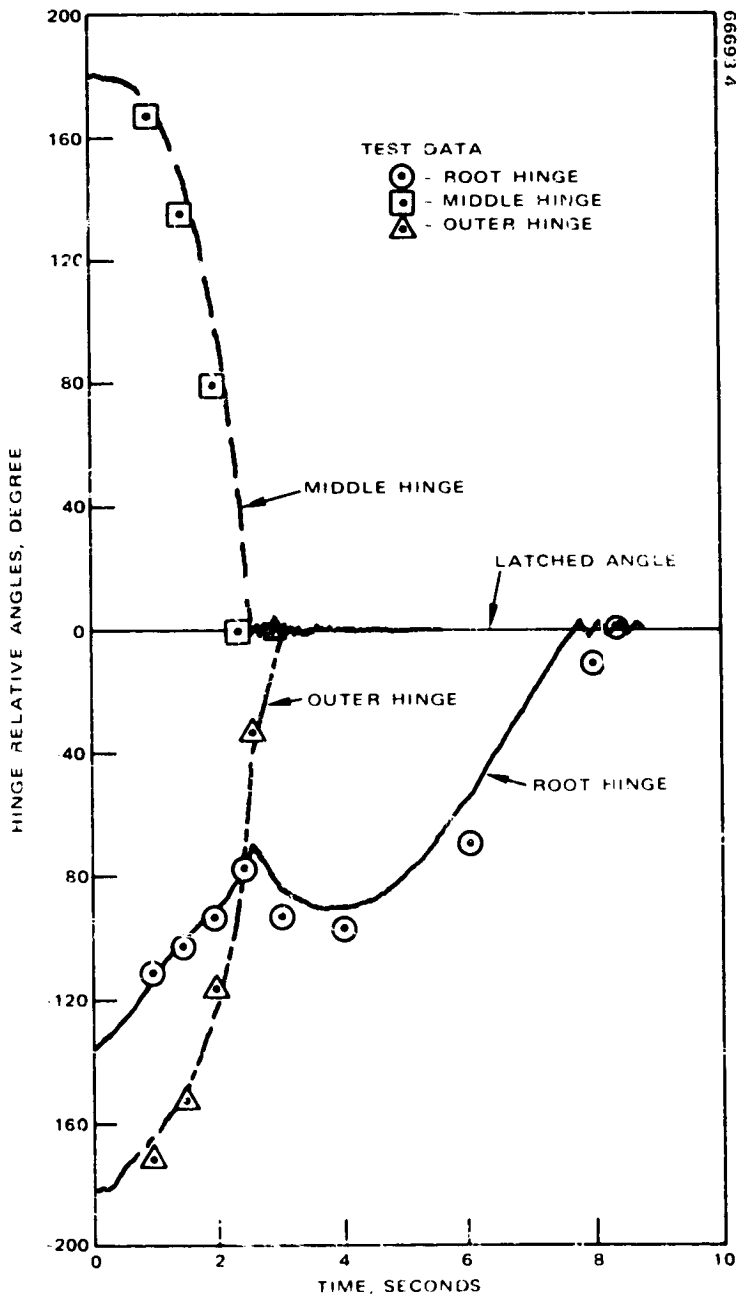

FIGURE 8. SIMULATION OF 9.0 RPM DEPLOYMENT IN 95% HELIUM

N78

19030

UNCLAS