

N78

19040

UNCLAS

GEOS – 20 m Cable Boom Mechanism
By Günter K. Schmidt and Klaus Suttner
Dornier System GmbH – Germany

ABSTRACT

The GEOS Cable Boom Mechanism allows the controlled deployment of a 20 m long cable in a centrifugal force field. In launch configuration the flat cable is reeled on a 240 mm diameter drum. The electrical connection between the rotating drum and the stationary housing is accomplished via a Flexlead positioned inside the drum. Active motion control of this drum is achieved by a self locking worm gear, driven by a stepper motor. The deployment length of the cable is monitored by an optical length indicator, sensing black bars engraved on the cable surface.

This paper describes the design, development, and testing of the operational modules.

Drum with Cable and Flexlead
Worm gear drive with stepper motor
and
Deployment length indicator

1. INTRODUCTION

GEOS is a scientific geostationary satellite spinning at 10 rpm in orbit. The payload consists of seven experiments with approximately 30 modular units. Most of the experiment probes and sensors had to be positioned at specific distances from the S/C surface to reduce body interference. The location and orientation requirements of these probes led to the design of a Boom and Mechanism Subsystem comprising of 8 different booms and 5 mechanisms. Two of the booms are 20 m long Cable Booms serving two active electronic sensors at their tips. During launch these sensors are stowed tangentially on the spacecraft surface in experiment containers. When released, these containers are opened to allow the sensors to swing out. The swinging motion is damped by a release system and a tubular damper. This release system is called the "Experiment Release Mechanism" and was presented by Mr. G. Bring from ESA at the May 76 Symposium in Frascati, Italy. (Ref. 1). After the release motion is damped out, the two boom cables are radially deployed by their "Cable Boom Mechanisms", which are positioned inside the Spacecraft below the lower equipment shelf.

2. BASIC DESIGN REQUIREMENT

Deployment length is 20 m.
Deployment accuracy is ± 5 cm.
Intermittant synchronous deployment in 10 cm steps and general start-stop mode.
Test retractability and limited retractability in orbit.
All bearings are dry lubricated.
Maximum power consumption is 35 W.
Maximum height is 270 mm.
Magnetic cleanliness has to be achieved.
1 Dipole and 10 connection lines for signals and power between tip sensor and S/C.
Operation in vacuum between -20 and $+55^{\circ}\text{C}$.

3. FUNCTIONAL DESIGN CHARACTERISTICS

A brief description of the Cable Boom Mechanism design is shown in Fig. 1. Additional details are provided in a Design Study Report. (Ref. 2). The following will highlight the more interesting functional groups: --

- Cable and Flexlead
- Worm gear drive
- Stepper motor
- Optical deployment sensor.

4. CABLE AND FLEXLEAD

For GEOS a flat cable of 1,5 x 7,3 mm cross section, consisting of five pairs of signal- and power leads AWG 36 and one AWG 24 central load wire with 60 pf/m lead capacitance was used. (Fig. 2). The cable was braided with twelve AWG 42 conductors and covered with gold plated Kapton tape. One side was painted with 2 x 6 mm black bars spaced at 10 mm intervals for the optical length indications. The cable was manufactured by HABIA, Sweden. Further details and dynamics of this cable are provided in Ref. 3.

Major problems were created by use of the Kapton tape. Due to poor gold adhesion of the standard tape, the gold had to be vapor deposited in an ultra high vacuum chamber. Following this process, a double sided self adhesive scotch tape was applied to the inner surface of the gold plated Kapton tape. The tape was then wrapped around the braided cable body.

The Flexlead which is attached to the stationary housing is positioned within the cable drum. It is reeled on the centre hub in the stowed configuration and unreels onto the inner surface of the worm wheel fixation ring in the deployed configuration.

The Flexlead cable which electrically connects the rotating drum and the stationary housing, is a flat teflon cable of 0,5 x 14 mm cross section with sixteen AWG 30 leads. The cable complied with specified capacitance and impedance values. This cable was also developed and manufactured by HABIA, Sweden.

To assure reliable performance, one side of the Flexlead cable is required to be as flat as possible to reduce lateral forces between the layers during unreeling. The results of tests and post test analyses led to a design shown in Fig. 3.

The geometrical lay-out of the Flexlead is based on the following equations.

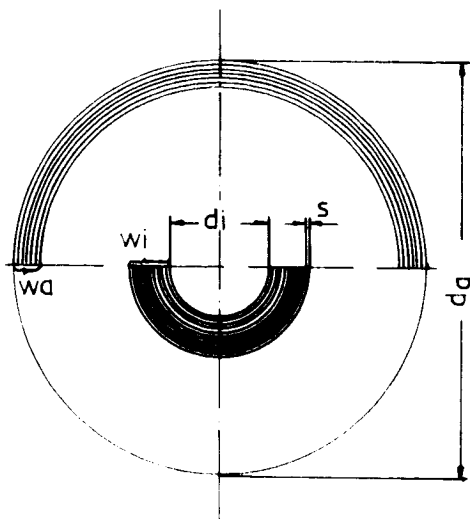

1. $L = d_m \cdot w \cdot \pi$
2. $d_{mi} = d_i + W_i \cdot S$
 $d_{ma} = d_a + W_a \cdot S$
3. $n = W_i - W_a$

L = Flexlead length
 W_i = number of inner windings
 W_a = number of outer windings
 n = number of revolutions
 S = Flexlead cable thickness
 d_i = inner diameter
 d_a = outer diameter

using the dimensionless Factors

$$\frac{d_i}{s} = \sigma \quad \frac{d_a}{s} = \delta \quad \frac{L}{s} = \lambda$$

the following Flexlead equation can be derived:

a) Range of definition: $d_i \leq d \leq d_a$

$$\frac{n}{\sigma} = \sqrt{\frac{1}{4} + \frac{\lambda}{\sigma^2 \tau}} + \sqrt{\frac{\delta^2}{4} - \frac{\lambda}{\sigma^2 \tau}} - \frac{1}{2}(1 + \delta)$$

b) differentiated for maxima:

$$\frac{n_{max}}{\sigma} = \sqrt{\frac{4\lambda_{max}}{\sigma^2 \tau} + 1} - \sqrt{\frac{2\lambda_{max}}{\sigma^2 \tau} + \frac{1}{4}} - \frac{1}{2}$$

The Flexlead Diagram, see Fig. 4, includes equations (a) and (b). For GEOS the following parameters were used:

$$\delta = 6 \quad \sigma = 58 \quad \frac{n}{\sigma} = 0,64 \quad \frac{\lambda}{\sigma^2} = 6,4$$

A Flexlead cable length of 12 m for 37 reel revolutions was derived from this diagram. A coiling factor of 0,9 was used.

The Flexlead was built and tested according to these parameters and performed successfully.

5. WORM GEAR DRIVE

For a cable boom system, a worm gear drive has fundamental advantages. Since cable booms deploy by the action of centrifugal force induced by the spinning satellite, deployment forces need not be provided. The task of the gear in this case is to prevent uncontrolled deployment. This can be obtained in a very efficient way with a self locking worm gear. The lower the self locking efficiency, the lower the torque requirement at the worm shaft necessary to control deployment motion. Thus, deployment control can be accomplished with a very small motor.

However, these operational conditions with the use of dry lubrication require a very careful design of the worm gear configuration and material selection. Of considerable importance are stable friction conditions between worm and worm wheel.

Several material combinations were tested in a special test to determine their frictional behaviour as a function of operation time. Excellent results were obtained with a titanium worm and a HOSTAFLOX worm wheel. In actuality, the initial friction of this combination is rather high. However, the friction reduces after a run-in period to a very constant value. A friction value of about $\mu = 0,16$ to $0,18$ was determined as the result of these friction investigations. Considering this value and the configuration data the gear data was thereby chosen:

pitch 2 mm
gear ratio 100
pitch angle $6,33^\circ$

With this gear design and the available torque of the stepper motor, an operational range of $\mu = 0,11$ to $0,25$ was achieved, providing a sufficient safety margin. The design parameters for the worm gear can be obtained from the worm gear Nomogram (Fig. 5) which was specifically developed for this drive assembly.

Full conformity between design and actual hardware was demonstrated during qualification testing.

6. THE MOTOR

A size 11, 4 phase variable reluctance stepper motor was chosen to drive the Cable Boom Mechanism.

Even considering the poor efficiency of these motors, they provide several important advantages:

- Small rotational speed without gear head and speed variation capability
- High calculated reliability due to minimal amount of mechanical parts
- Low residual magnetism following switch off
- Digital servo electronics
- Simple electronic synchronisation of several motors.

The motors, used for the GEOS Cable Boom Mechanisms, were specially developed by SAGEM, France. These stepper motors can provide a starting torque of more than 25 Nmm. The length of the housing is 52 mm and its mass 125 g. The motor has a step angle of 15° and runs with 12 Hz (speed A) and 48 Hz (speed B).

The motor is operated by a Motor Control Electronic (MCE), which functions in several deployment modes, with a synchronous four phase driver signal for two stepper motors.

7. DEPLOYMENT LENGTH INDICATOR

The purpose of the deployment length indicator is to measure the deployed length of the boom cable. It consists of the following:

- the optical head and
- the processing electronics.

The optical elements of the optical head consist of a matched pair of light emitting diode and photo transistor. The geometrical arrangement of both of these devices assure that the maximum possible amount of emitted light is reflected into the photo transistor. Reflectance is achieved by a gold plated cover tape on the Boom Cable, which passes under the optical head. Maximum reflection occurs when the optical axes of the light emitting diode and the photo transistor intersect in the plane of the cover tapes. The gold plated cover tape is marked with a periodic pattern of non-reflecting black bars, that are spaced 10 mm apart and are 2 mm wide. (Fig. 6).

The processing electronics generate a counting pulse when a bar has passed the optical head in either direction. However, no counting will occur if the bars are oscillating back and forth in the cable axis direction at amplitudes of less than 5 mm. To achieve this count deletion, a second optical element in the optical head is displaced from the first by 5 mm in the cable axis direction. Using the outputs of both optical elements, the counting pulses due to cable longitudinal oscillations are automatically suppressed by the processing electronics. For reliability purposes, the arrangement of the two optical elements is duplicated in the optical head, the outputs of the redundant photo transistors being OR-gated.

8. TESTING

The Cable Boom Mechanism as a unit was successfully tested at development, qualification and acceptance levels. The following environmental tests were carried out at unit level:

Vibration tests - sinus and random

Thermal - Vacuum test between -30° and $+60^{\circ}\text{C}$ at a pressure less than 10^{-7} Torr

Electromagnetic Cleanliness Tests

The environmental tests were accompanied by unit performance tests. The most significant and comprehensive performance test was accomplished by means of a special Unit Test Rig.

This Unit Test Rig consists of an electronic Unittester simulating the electrical interfaces to the Satellite, and a test fixture simulating the mechanical orbit conditions. It also allows the simulation of any required orbital deployment load characteristic.

The deploying cable is stored on a drum which simulates the cable load by means of a controllable torque motor. The torque profile is provided and monitored via the Unittester. The Cable Boom Mechanism itself is mounted on a base plate supported by bar springs. Strain gauges positioned at the bar springs measure the cable loads, applied to the drum.

The test fixture is very compact and enables simulated Cable Boom deployments also in small test chambers. In addition to these unit tests, comprehensive component tests were carried out with the Boom cable, and cable marks, Flexlead cable, stepper motor, worm gear, optical head and control electronics.

9. CONCLUSIONS

For the GEOS satellite a 20 m Cable Boom Mechanism was designed, developed and qualified. This effort was sponsored by the EUROPEAN SPACE AGENCY as part of the GEOS Development Contract.

The layout of the Flexlead and the worm gear required rather careful consideration. Problems associated with the adhesion of the gold layer and the black marks on the gold surface as well as with the optical head had to be solved.

However, due to the modular configuration and the availability of a parametric design lay-out and computer programs, the application of this mechanism is not limited to a 20 m cable, but can be easily adapted to other configurational requirements and applications. Longer and heavier cables can be deployed and retracted with a stronger motor for instance.

The application range of this mechanism covers 100 and more metres deployment length. If necessary, a deployment accuracy of less than 1 cm can be achieved.

10. REFERENCES

- 1) ESA SP 117, Presentation held in Frascati, Italy 24-26 May 1976 by G.L. Bring: Design Features and Zero Gravity Simulation of the GEOS Satellite Long Radial Boom Release.
- 2) ESTEC Publication Nr. 1511/71 AA by Dornier System GmbH, Günter K. Schmidt: Cable Boom System for Spin-Stabilized Satellites - Design, Development, and Testing.
- 3) ESTEC Presentation at the 8th Aerospace Mechanisms Symposium, October 1973 by G.L. Bring: Development of and Dynamic Studies Concerning a Cable Boom System Prototype.

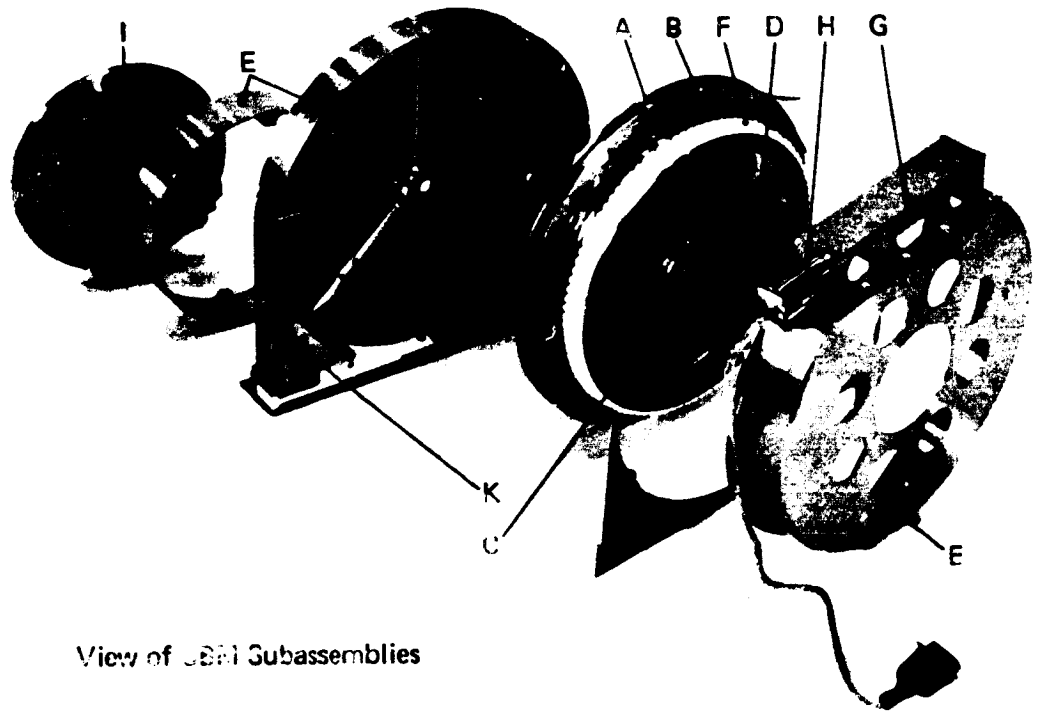
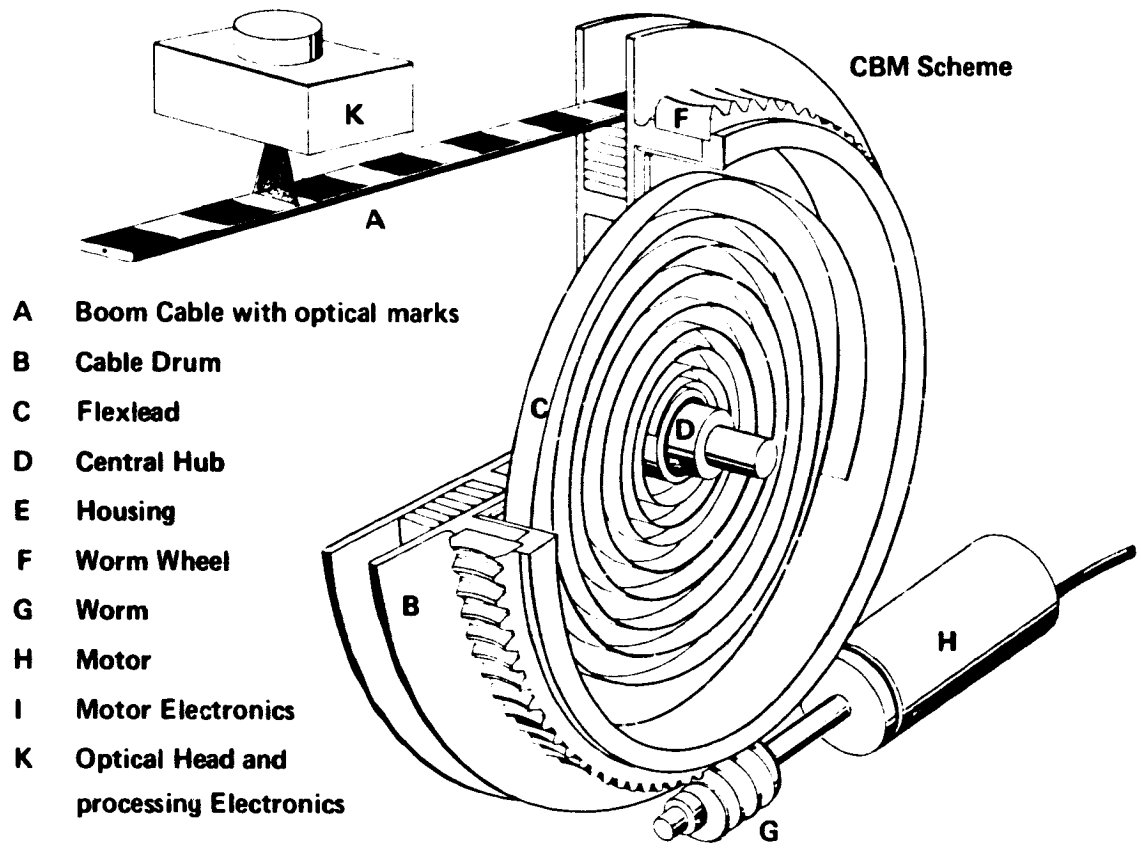

Fig. 1 GEOS - Cable Boom Mechanism

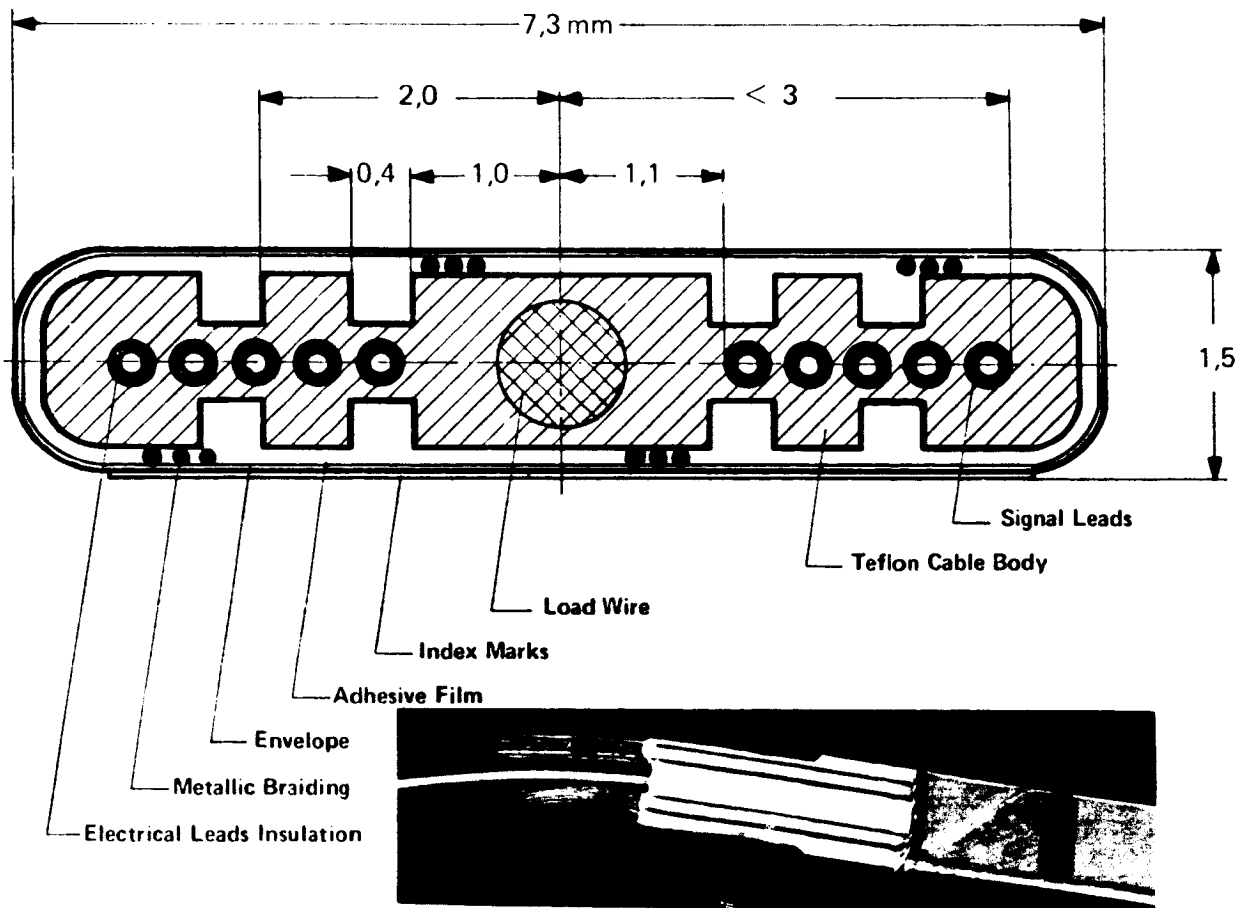

Fig. 2 LRB Cable Cross Section

SCALE 1 mm

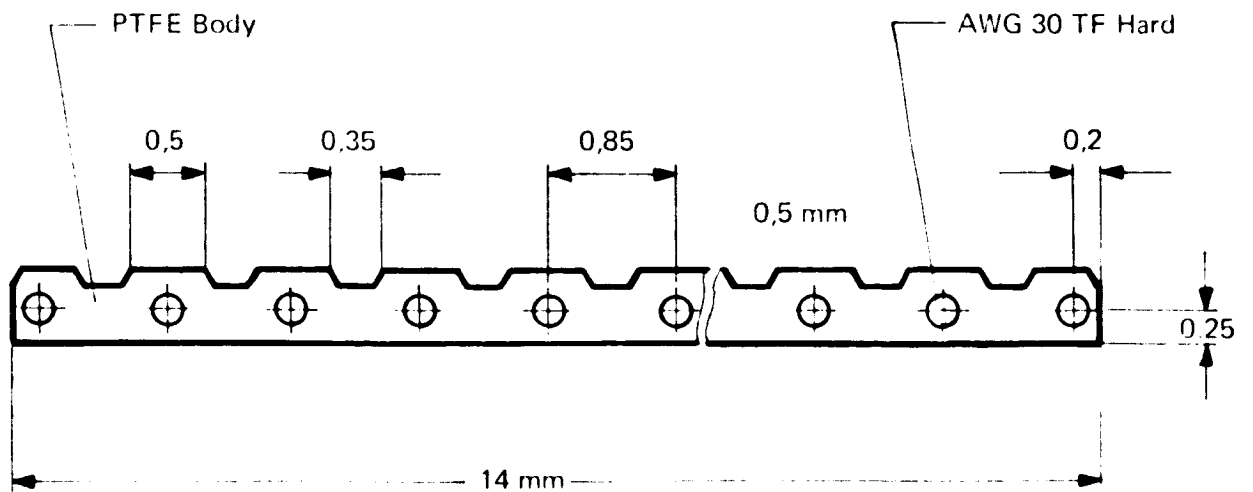

Fig. 3 Flexlead Cable Cross Section

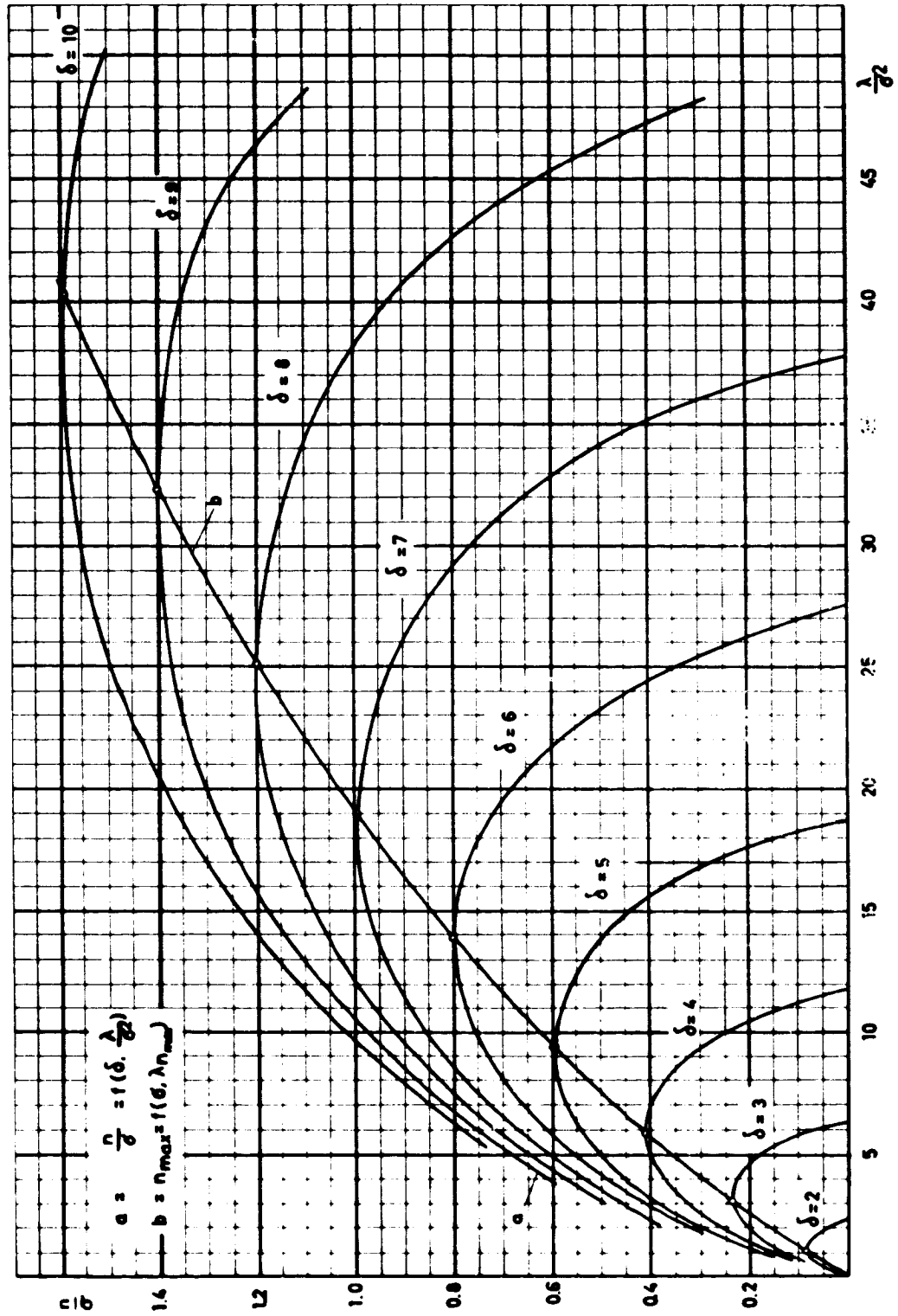

Fig. 4 Flexlead Diagram

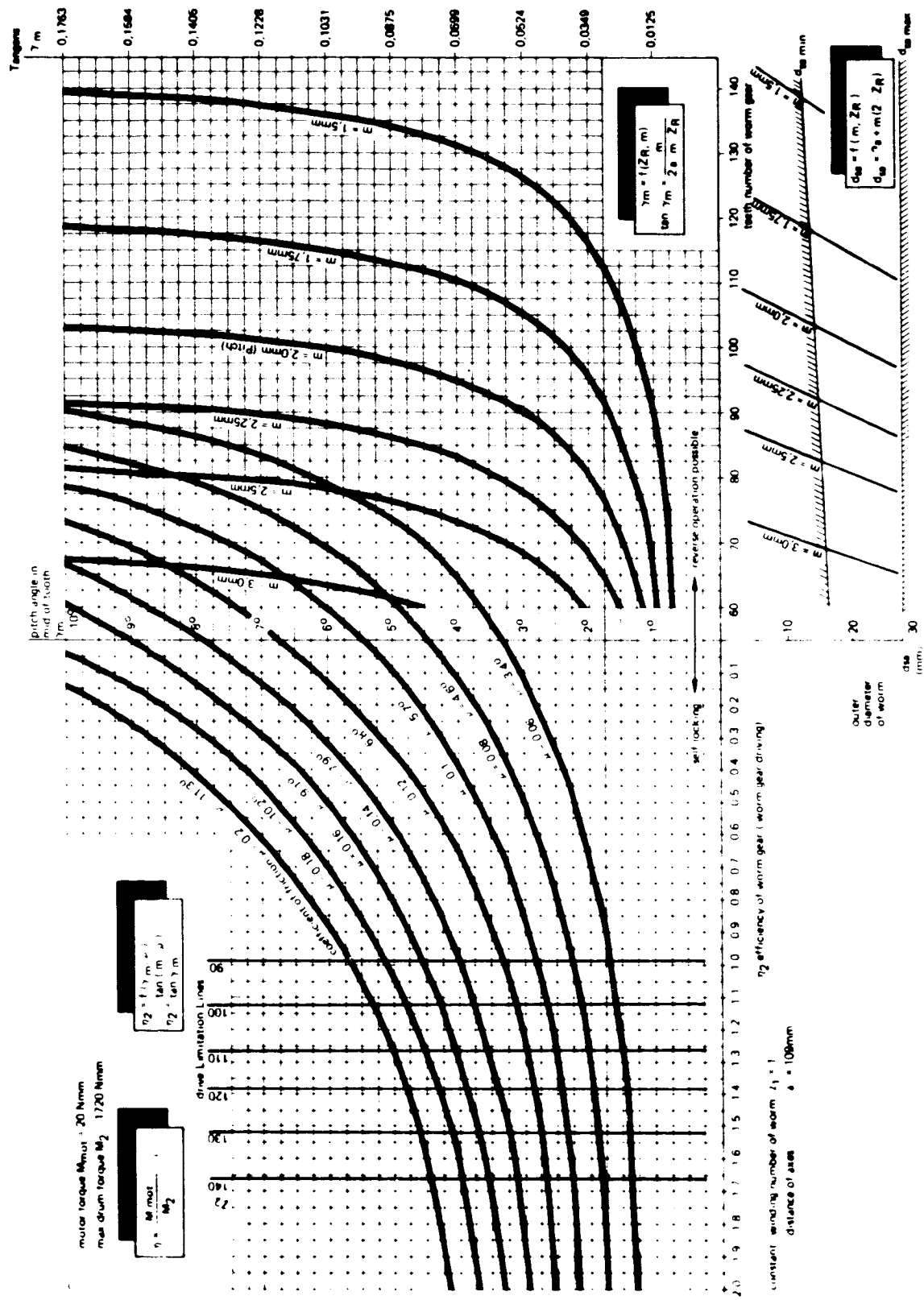

Fig. 5 Worm Gear Nomogram

REPRODUCIBILITY OF THE ORIGINAL PAGE IS POOR

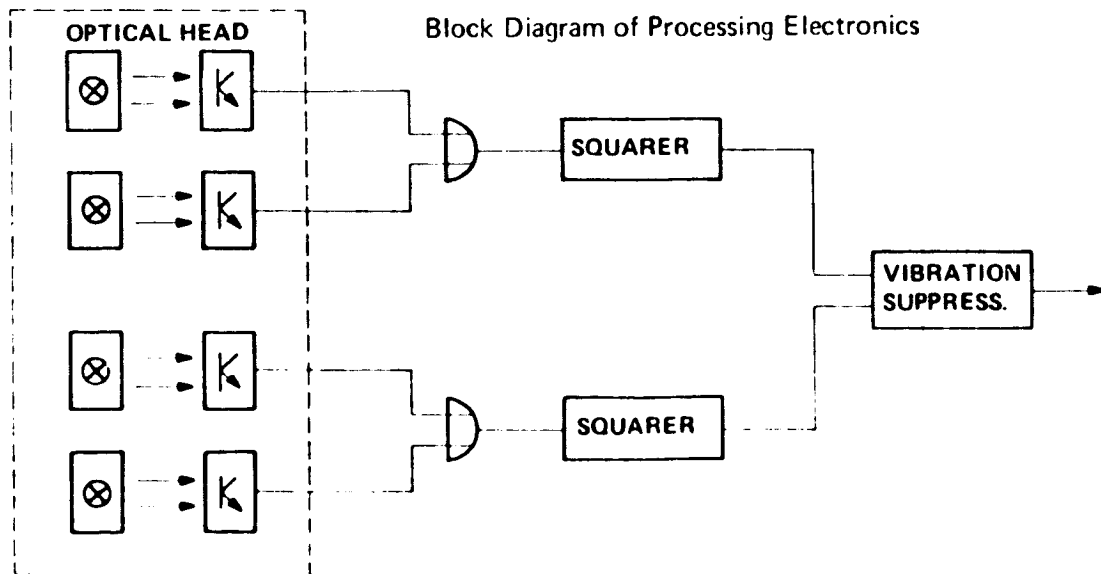
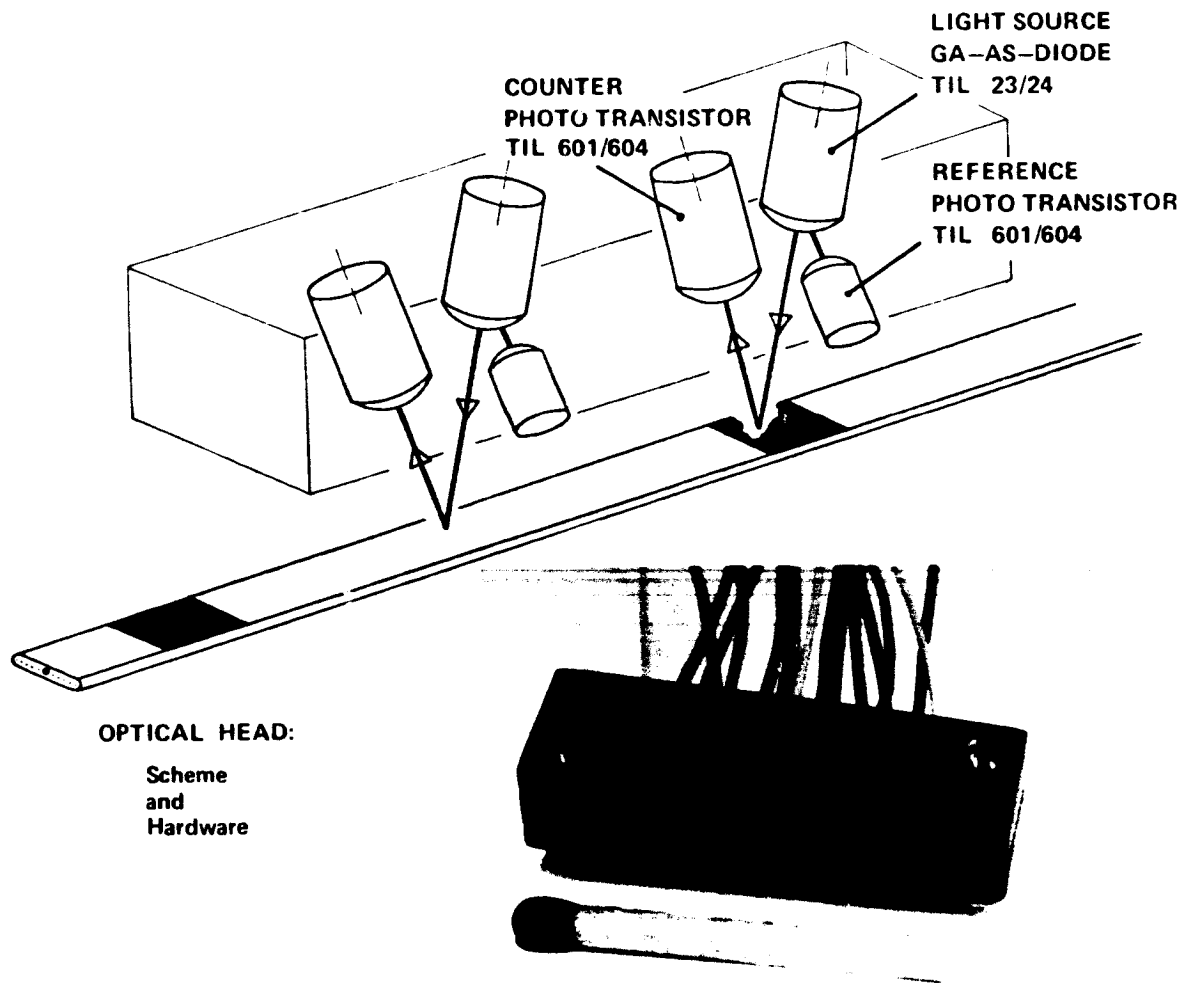

Fig. 6 Deployment Length Indication

N78

19041

UNCLAS