

NASA Contractor Report 145321

(NASA-CR-145321) STUDY OF HYPERSONIC
PROPULSION/AIRFRAME INTEGRATION TECHNOLOGY
Final Report (Rockwell International Corp.,
Los Angeles) 97 p HC A05/NF A01 CSCL 01C

N78-19096

Unclas

G3/05 09141

Study of Hypersonic Propulsion/Airframe Integration Technology

W.R. Hartill, T.P. Goebel,
and V.V. Van Camp

ROCKWELL INTERNATIONAL CORPORATION
Los Angeles, California 90009

CONTRACT NAS1-14859
JANUARY 1978

NASA

National Aeronautics and
Space Administration

Langley Research Center
Hampton, Virginia 23665

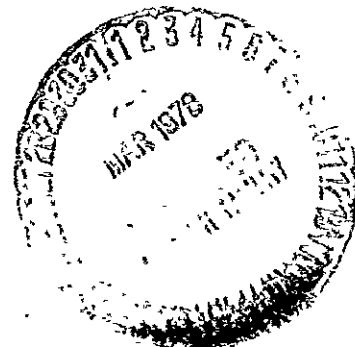

NASA Contractor Report 145321

Study of Hypersonic Propulsion/Airframe Integration Technology

W.R. Hartill, T.P. Goebel,
and V.V. Van Camp

ROCKWELL INTERNATIONAL CORPORATION
Los Angeles, California 90009

CONTRACT NAS1-14859
JANUARY 1978



National Aeronautics and
Space Administration

Langley Research Center
Hampton, Virginia 23665

1. Report No. NASA-CR-145321		2. Government Accession No.		3. Recipient's Catalog No.	
4. Title and Subtitle STUDY OF HYPERSONIC PROPULSION/AIRFRAME INTEGRATION TECHNOLOGY				5. Report Date January 1978	
				6. Performing Organization Code	
7. Author(s) William R. Hartill, Thomas P. Goebel, and Verle V. Van Camp				8. Performing Organization Report No. NA-78-24	
9. Performing Organization Name and Address Los Angeles Division Rockwell International International Airport, Los Angeles, CA 90009				10. Work Unit No.	
				11. Contract or Grant No. NAS1-14859	
				13. Type of Report and Period Covered Contractor Report	
12. Sponsoring Agency Name and Address National Aeronautics and Space Administration Langley Research Center Hampton, Virginia 23665				14. Sponsoring Agency Code	
15. Supplementary Notes Final Report Langley Technical Monitor: J. P. Weidner					
16. Abstract This report describes an assessment of current and potential ground facilities, and analysis and flight test techniques for establishing a hypersonic propulsion/airframe integration technology base. A mach 6 cruise prototype aircraft incorporating NASA Langley Research Center integrated Scramjet engines was considered the baseline configuration, and the assessment focused on the aerodynamic and configuration aspects of the integration technology. The study describes the key technology milestones that must be met to permit a decision on development of a prototype vehicle, and defines risk levels for these milestones. Capabilities and limitations of analysis techniques, current and potential ground test facilities, and flight test techniques are described in terms of the milestones and risk levels.					
ORIGINAL PAGE IS OF POOR QUALITY					
17. Key Words (Suggested by Author(s)) Hypersonic vehicle, propulsion integration, Scramjet, hypersonic testing			18. Distribution Statement		
19. Security Classif. (of this report) UNCLASSIFIED		20. Security Classif. (of this page) UNCLASSIFIED		21. No. of Pages 95	22. Price*

TABLE OF CONTENTS

	Page
SUMMARY	1
INTRODUCTION	3
SYMBOLS	6
STUDY FOCUS	7
Prototype Aircraft Concept	7
Flight Regime	9
METHODOLOGY AND TEST TECHNIQUES	9
Design Conception	15
Airframe Configuration	17
Scramjet Configuration	21
Design Integration	31
INTEGRATION TECHNOLOGY MILESTONES	39
Milestone Description	39
Key Milestone Technology Risk Levels	43
TEST FACILITY APPLICATION	43
Current Facility Limitations	43
New Facility Potential	55
Role of the Hypersonic Research Airplane	68
HYPERSONIC RESEARCH AIRPLANE CHARACTERISTICS	76
Configuration	76
Flight Performance	77
Flight Test Program	79
Flight Instrumentation	81
Flight Test Data Application	84
CONCLUSIONS	85

	Page
RECOMMENDATIONS	86
REFERENCES	87

LIST OF ILLUSTRATIONS

Figure	Title	Page
1	Propulsion/airframe integrated hypersonic vehicle.	4
2	Three-view Rockwell proposed study basepoint	8
3	Scramjet prototype aircraft nominal flight corridor.	10
4	Free-stream total pressure in flight corridor.	11
5	Free-stream total temperature in flight corridor	12
6	Free-stream Reynolds number per meter in flight corridor . . .	13
7	Integration process logic diagram.	16
8	Exhaust gas simulation effectiveness - nozzle surface pressures.	28
9	Concept for testing with nozzle extension bolted to rear portion of engine to evaluate engine plus nozzle internal drag and thrust.	30
10	Primary integration design considerations.	32
11	Basic force accounting	38
12	Current ground-based facility simulation of flight vehicle Reynolds number.	48
13	Maximum scramjet module scale test capability in full-flight simulation current ground facilities	60
14	New ground facility potential for Reynolds number simulations.	62
15	Single-module scale limits with new facility full-flight simulation	66
16	X-1 rocket powered supersonic flight test vehicle - 1947 . . .	71
17	X-7 Supersonic Ramjet flight test vehicle - 1953	72
18	X-15 rocket powered hypersonic flight test vehicle	73

LIST OF TABLES

Table	Title	Page
I	Listing of Viscous Phenomena	35
II	Integration Milestones	40
III	Technology Risk Levels	44
IV	Current Ground Facilities.	47
V	New Ground Facilities.	57
VI	Impact of New Facilities on Milestone Risk Levels.	58
VII	Milestone Risk Factor Comparison	69
VIII	New Ground Facility Estimated Costs.	70
IX	Hypersonic Research Airplane List of Standard Instrumentation.	82
X	Hypersonic Research Airplane List of Special Instrumentation.	83

STUDY OF HYPERSONIC PROPULSION/AIRFRAME
INTEGRATION TECHNOLOGY

William R. Hartill
Thomas P. Goebel
Verle V. VanCamp
Rockwell International
Los Angeles Division
Los Angeles, California

SUMMARY

This report describes a study of the technology of hypersonic propulsion/airframe integration. The study is an assessment of current and potential ground facilities, analysis techniques, and flight test techniques to establish a hypersonic propulsion/integration technology base. Focus of this study is on the aerodynamic and configuration aspects of integration, which do not address the structural, thermal protection or operational considerations.

Basepoint of interest is technology development for a Mach 6 cruise prototype aircraft incorporating NASA Langley Research Center integrated scramjet engines. Integration technology milestones are defined that, upon completion, would permit a go-ahead decision on development of a prototype aircraft. The major events and technical accomplishments that could measure progress and confidence are listed and placed as gates in assessing current and proposed ground test facilities, flight test techniques, and analytic methods.

It was found that analytic design methods are inadequate to define the complex three-dimensional (3-D) flow interactions of the integrated concepts. Experimental methods normally used to reinforce and bypass inadequate theory were themselves found to be inadequate and incapable of reducing prototype development risk to an acceptable level.

The primary cause of this situation is that this class of vehicle cannot reasonably be designed and developed without the simultaneous representation and accounting of the airframe and propulsion geometry and operation. It is not possible, as it is at lower speeds, to carry on separate development with a final match-up and absorption of unexpected performance penalties. Furthermore, the scramjet engine requires a true high-enthalpy airstream for operation which is difficult to reproduce in ground test facilities except in small scale. The scramjet does not lend itself to scale reduction and there is little experience available to place limits and guide extrapolations. The

result is that an integrated airframe/scramjet vehicle configuration cannot be tested at hypersonic speeds in any current ground-based facility. Construction of new, larger capacity ground test facilities would only partially alleviate this problem. The cost of sufficiently large facilities is considered prohibitive.

A hypersonic flight test program, however, would meet the technology development requirements. An air-launched, manned Hypersonic Research Aircraft (HRA) with a length of approximately 21 m would provide the best platform for obtaining the airframe/propulsion design criteria.

Additionally, work should be carried on in upgrading and expanding current ground facilities to support hypersonic integration studies. A key element in facility utilization is the establishment of scaling criteria, size limits, and development of a minimum-sized scramjet simulator.

**ORIGINAL PAGE IS
OF POOR QUALITY**

INTRODUCTION

The application and integration of air-breathing engines to hypersonic aircraft has long been recognized as the key to the development of hypersonic atmospheric flight (refs. 1 through 3). Turbojet, ramjet, and scramjet engines generate significantly higher specific fuel impulse than rocket engines and so are more efficient for atmospheric propulsion. However, these engines operate at thrust coefficients that decrease with increasing flight velocity. To generate sufficient thrust at hypersonic velocities, the amount of air handled by these engines must be significantly greater than the case at lower speeds. This requirement means that the inlet, engine, and exhaust nozzle of the hypersonic propulsion system become such a large proportion of the air-frame configuration that it is not feasible to design and develop the vehicle independent of the propulsion system.

As shown in figure 1, a typical hypersonic research aircraft concept, the entire vehicle undersurface is devoted to the propulsion system. The forebody acts as an inlet compression ramp, the central body/wing section contains the engine combustion modules, and the entire afterbody forms an exhaust nozzle surface.

The refinement of such hypersonic vehicle shapes to give high lift-drag (L/D), low aerodynamic heating, and acceptable stability characteristics has become a doubly challenging task with recognition of the critical importance of the propulsion system configuration. Progress has been made in developing such shapes, and synergistic benefits have been identified for these integrated design approaches (refs. 4 through 7). However, these studies have also shown that the vehicle and propulsion forces involved are of such critical magnitude and are of such complex nature that the technology base requires further expansion to support the design of future hypersonic vehicles.

A number of studies have shown that the major problem area in realizing the technology potential has been the failure of ground-based experimental facility capabilities to keep pace with the needs of hypersonic vehicle technology (refs. 8 and 9). This has come about as the logistical limits of wind-tunnel testing have been approached, and new-generation, advanced technology facilities have not reached the capacity and characteristics needed. One remedy to this technology choke point has been to transfer experimental studies to flight test, thus avoiding the ground-based facilities problems and economic limitations. The X-15 is a notable example of a hypersonic flight test program that provided a substantial step-up in technology (ref. 10). Although the X-15 did not test integration of air-breathing propulsion systems, it did establish a good base for hypersonic flight test techniques. In the 9 years since the termination of the X-15 program, the importance of, and need for, advances

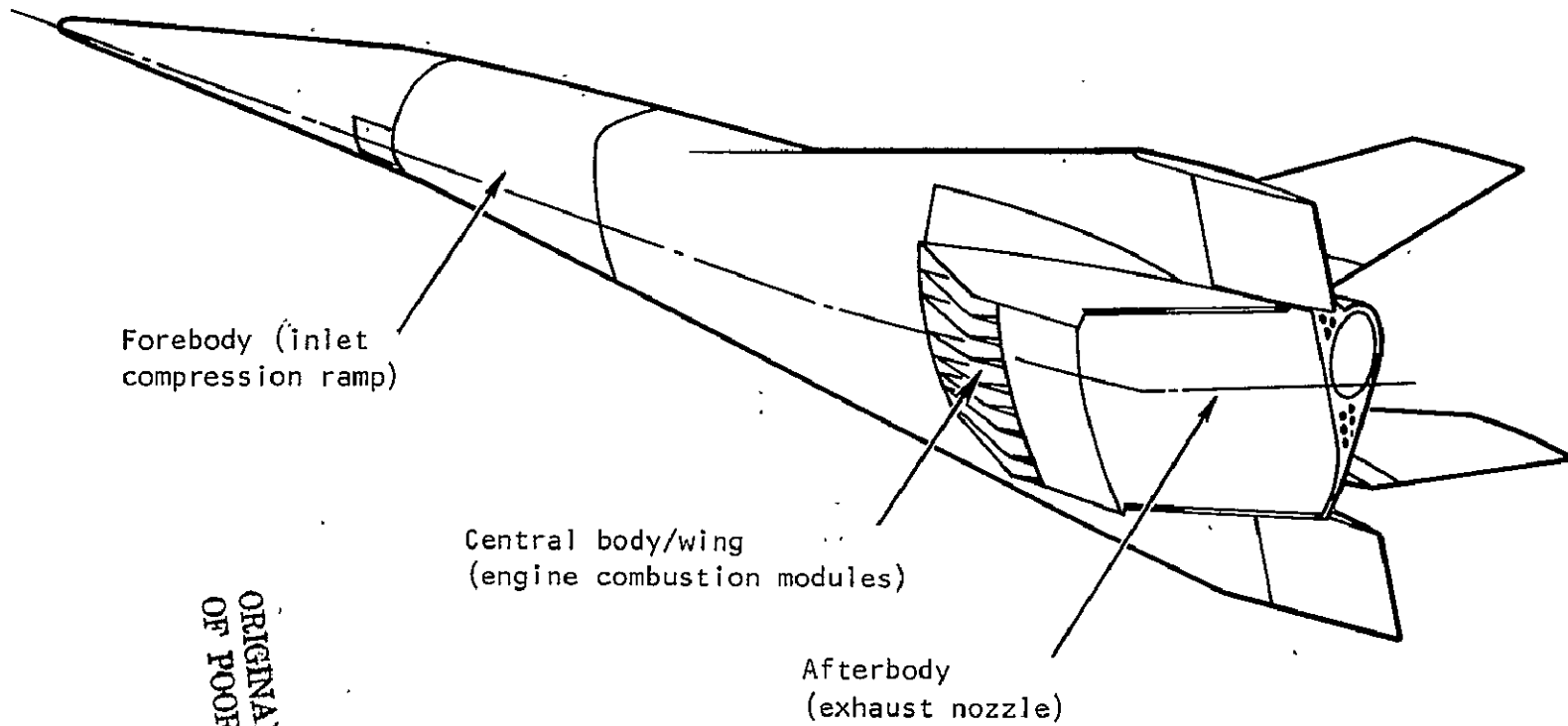

ORIGINAL PAGE IS
OF POOR QUALITY

Figure 1.- Propulsion/airframe integrated hypersonic vehicle.

in hypersonic aircraft technology has been confirmed. In recognition of this, NASA and USAF have conducted a series of engineering studies which resulted in a number of hypersonic flight test vehicle conceptual designs such as the X-24C (ref. 11).

It is the purpose of this study to examine the methodologies and test techniques required to build an aerodynamic integration technology base and to identify the roles that may be played by ground facilities and flight test vehicles in developing that base for a Mach 6 scramjet integrated prototype aircraft.

SYMBOLS

C_D	drag coefficient
C_{D_0}	drag coefficient at zero lift
C	test section area
h	module height
l	module length
L	body length
L/D	lift-to-drag ratio
T/D	thrust-to-drag ratio
A_c	module capture area
q	freestream dynamic pressure
Re	unit Reynolds number
ReL	Reynolds number based on body length
Φ	equivalence ratio
HRA	hypersonic research airplane
NHFRF	National Hypersonic Flight Research Facility
REF	risk exposure factor
F	ground test facility
NF	new ground test facility

STUDY FOCUS

This study focuses on the NASA LRC integrated scramjet concept and integration technology for a scramjet-powered, Mach 6 cruise prototype aircraft. The technology addressed is limited to aerodynamic and configuration analysis, and is not directly concerned with structural, thermal protection, and operational considerations.

Prototype Aircraft Concept

A number of missions, applications, and configurations have been studied and proposed which are related to military and commercial applications in the Mach 5 to 12 speed range. These studies have indicated a general configuration class characterized by aerodynamic blending of wing, body, and ramjet/scramjet engines. Size of these vehicles ranges from a length of 15 m or more for a manned flight research vehicle, to more than 90 m for a hypersonic transport. NASA and the USAF have studied the feasibility of developing a new manned flight research vehicle as an extension of the X-24C research vehicle work (ref. 11). These studies have led to the funding of a conceptual preliminary design study by the USAF for a National Hypersonic Flight Research Facility (NHFRF) vehicle that could be used to explore the technology of air-breathing, hypersonic flight (ref. 12). The general characteristics of a NHFRF-type vehicle such as the Rockwell-proposed D590-8, (figure 2) have been found sufficiently similar to a broad range of hypersonic vehicles such that a scramjet integration development plan based on it would have general application. Although the size differential may be large between some of the vehicle concepts and NHFRF, affecting Reynolds number scaling and facility limitations, the D590-8 type NHFRF should provide a good focus for the study.

The overall length of this vehicle is 21 m, wingspan is 7.87 m and launch is by air-drop from the B-52. Acceleration is to be provided by either one Rocketdyne LR-105 engine (LOX-RP fuel) or one Aerojet YLR-99 (LOX-NH₃ fuel) with cruise rocket propulsion supplied by either 12 Rocketdyne LR-101 engines or two Aerojet XLR-11 engines mounted in the base region of the fuselage. The scramjet experimental installation consists of four NASA LRC modules located on the bottom of the fuselage. These modules are 56 cm deep, 3.2 m long, and are fueled with liquid hydrogen (ref. 6).

The scramjet propulsion system involves the entire undersurface of the vehicle, as the system is being sized to cruise the vehicle at Mach 6 on scramjet power alone. The fuselage forebody acts as a precompression ramp for the air captured by the engine. The modules contain, in a relatively compact package, the inlet cowling, fuel injection struts, combustor, and initial nozzle expansion duct. Aft of the modules, the fuselage is contoured

GEOMETRIC DATA

ITEM	WING (TOTAL)	VERTICAL TAIL
AREA	761 SQ FT	109 SQ FT
ASPECT RATIO	0.877	0.963
TAPER RATIO	0.329	0.417
LEADING EDGE SWEEP	68°	50°
AIRFOIL	AERO DEFINITION (t/c = .045)	10° WEDGE TO 60% CHORD
SRAN	310.0	123.0
ROOT CHORD	546.0	181.0
TIP CHORD	161.0	75.5
MEAN AERO CHORD	388.438	135.518
ROOT TO MAC	63.43	53.068
DIHEDRAL	0° LOWER SURFACE	-
INCIDENCE	-2.9°	-

PROPULSION	
• ONE ROCKETDYNE LR-105 ENGINE (LOX - RP FUEL)	
• CRUISE PROPULSION - 12 ROCKETDYNE LR-101 THRUST UNITS (LOX - RP FUEL)	
• FOUR 24 IN. SCRAMJETS (LIQUID HYDROGEN)	

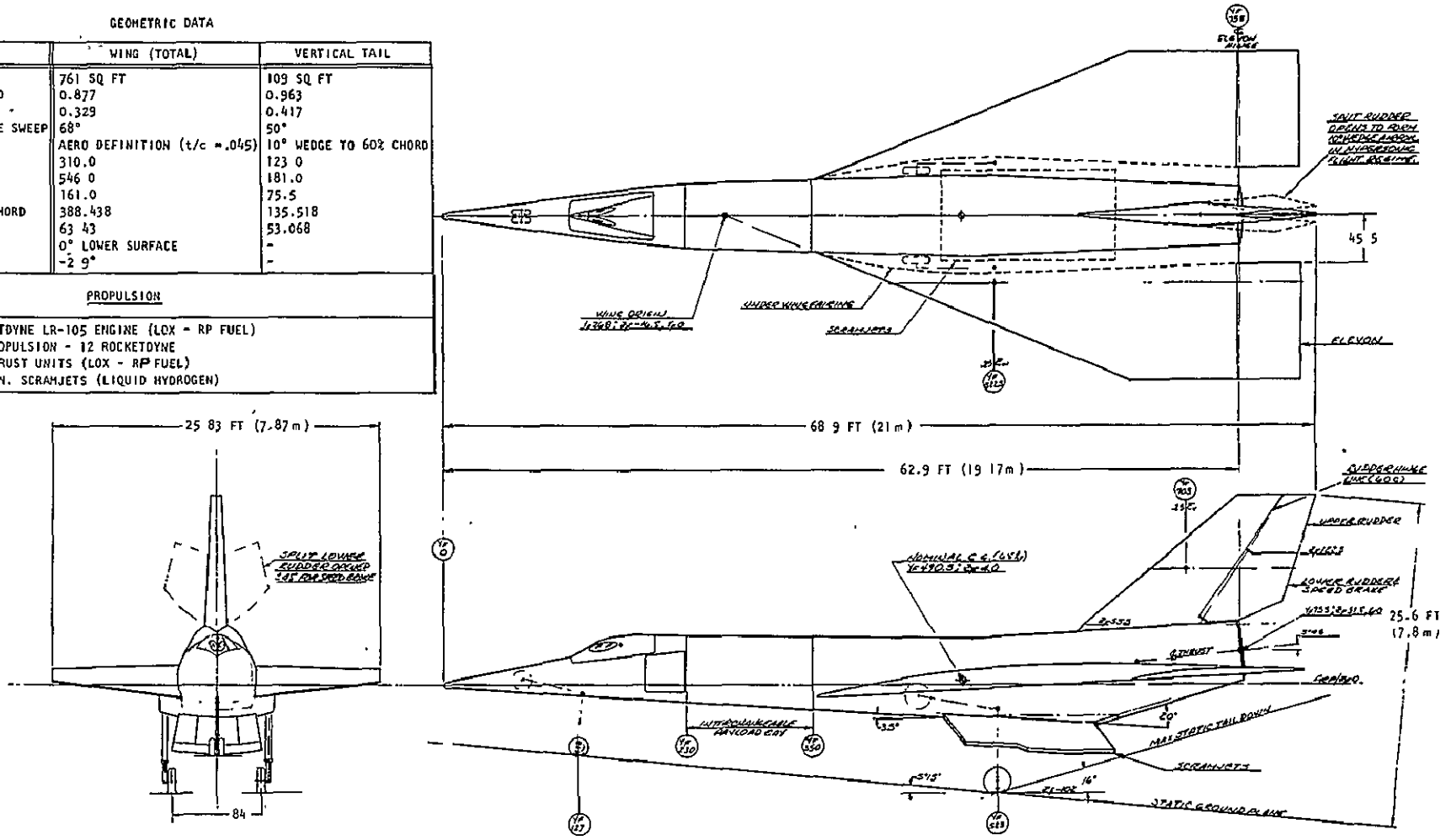

ORIGINAL PAGE IS OF POOR QUALITY

Figure 2. - Three-view Rockwell proposed study basepoint.

to serve as a continuation of the nozzle expansion surface in support of the requirement for a large nozzle area ratio.

Flight Regime

A scramjet-powered vehicle must fly in the earth's atmosphere within certain altitude limits. These limits are not exactly defined because of the wide range of operating conditions that a scramjet vehicle may be designed for. In general, a flight corridor can be defined, such as the one depicted in figure 3, on the basis of constant q (dynamic pressure) lines of 23.94 and 71.82 kN/m². A typical design condition is a $q = 47.88$ kN/m². Higher altitude (lower q) results in reduced aerodynamic lift effectiveness and also limits the ability to initiate and maintain combustion in a reasonable length scramjet module. Lower altitude (higher q) results in greater pressure loads on the vehicle and modules, requiring excessive structural weight. Also, the higher q generates high heat loads on the structure which is then limited by the vehicle thermal protection system characteristics.

Speed ranges under consideration for scramjet-powered vehicles include takeoff through the hypersonic regime (Mach 0.3 to 10). In addition to hypersonic speeds, the scramjet may be used to produce usable thrust and/or aftbody drag reduction in a subsonic combustion mode at lower speeds.

The flight conditions of stagnation pressure, temperature, and unit Reynolds number for the selected flight corridor are plotted respectively in figures 4, 5, and 6. The design point of primary interest is at $q = 47.88$ kN/m² at Mach 6. At this point, the altitude is 27.3 km; stagnation pressure 3,627 kN/m², stagnation temperature, 1660 deg K, and Reynolds number, 3.65×10^6 per meter.

METHODOLOGY AND TEST TECHNIQUES

Hypersonic integration methodology has developed as an extension of the current state-of-the-art in use for high-performance supersonic aircraft. This approach (supersonic) considers the airframe and propulsion as separate functions with initial primary design emphasis requiring that the airframe provide lift and control while the propulsion system provides thrust. Integration consists of, first, matching the engine size (thrust) and operating characteristics to the airframe so that the basic requirements of vehicle performance are met. This step requires that assumptions be made for engine installation effects and inlet and nozzle component efficiencies.

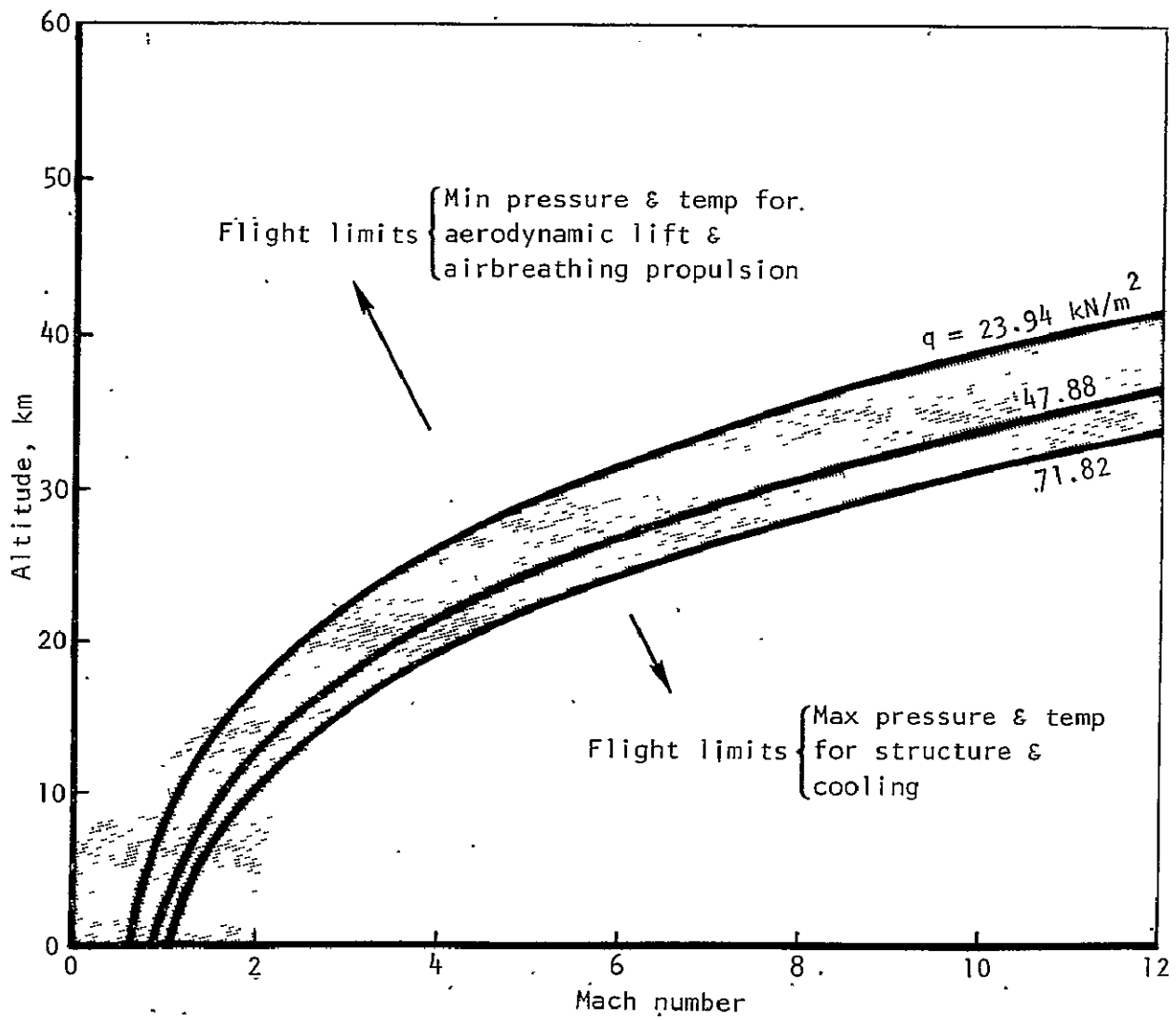

ORIGINAL PAGE IS
OF POOR QUALITY

Figure 3. - Scramjet prototype aircraft nominal flight corridor.

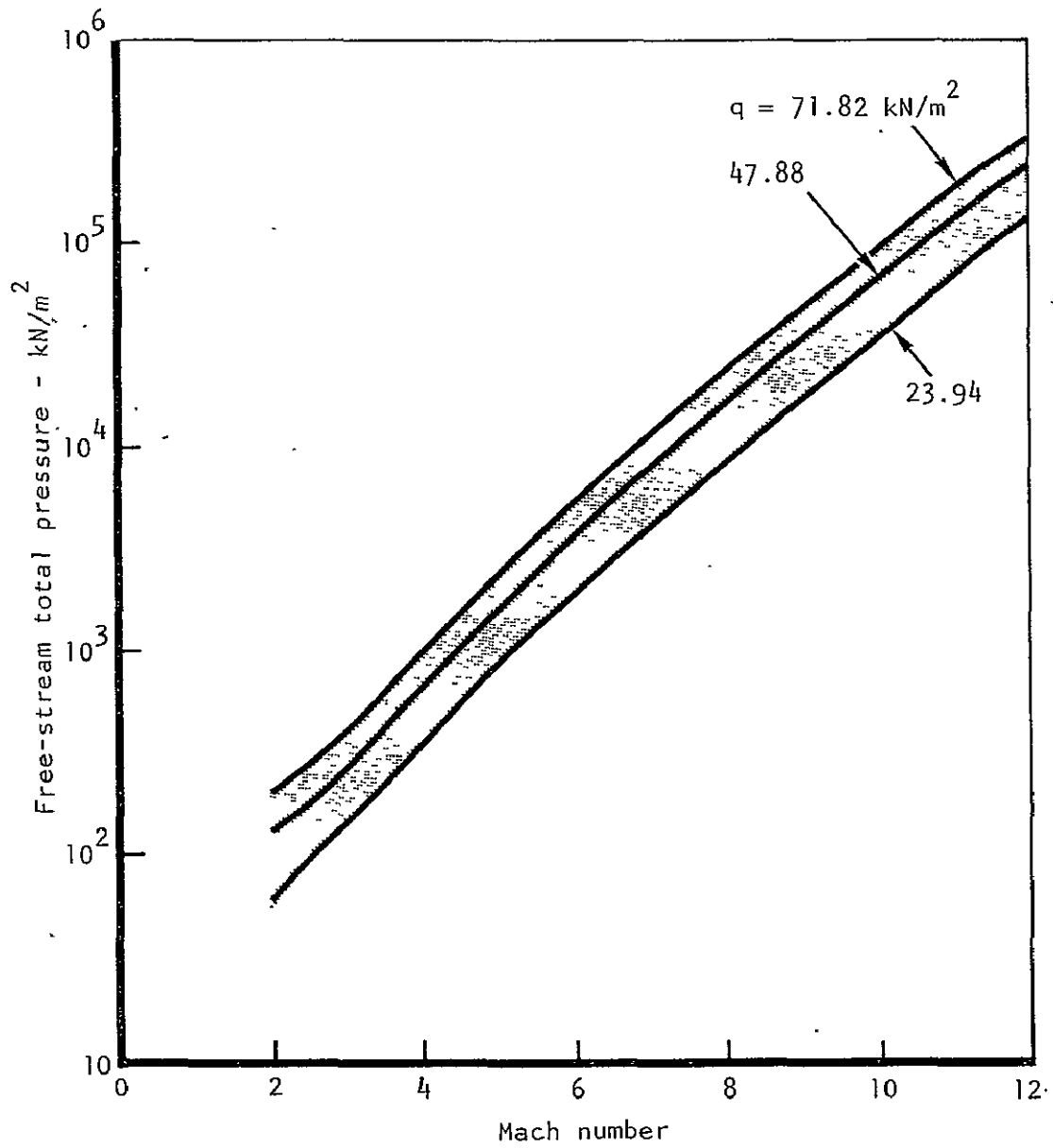

ORIGINAL PAGE IS
OF POOR QUALITY

Figure 4. -- Free-stream total pressure in flight corridor.

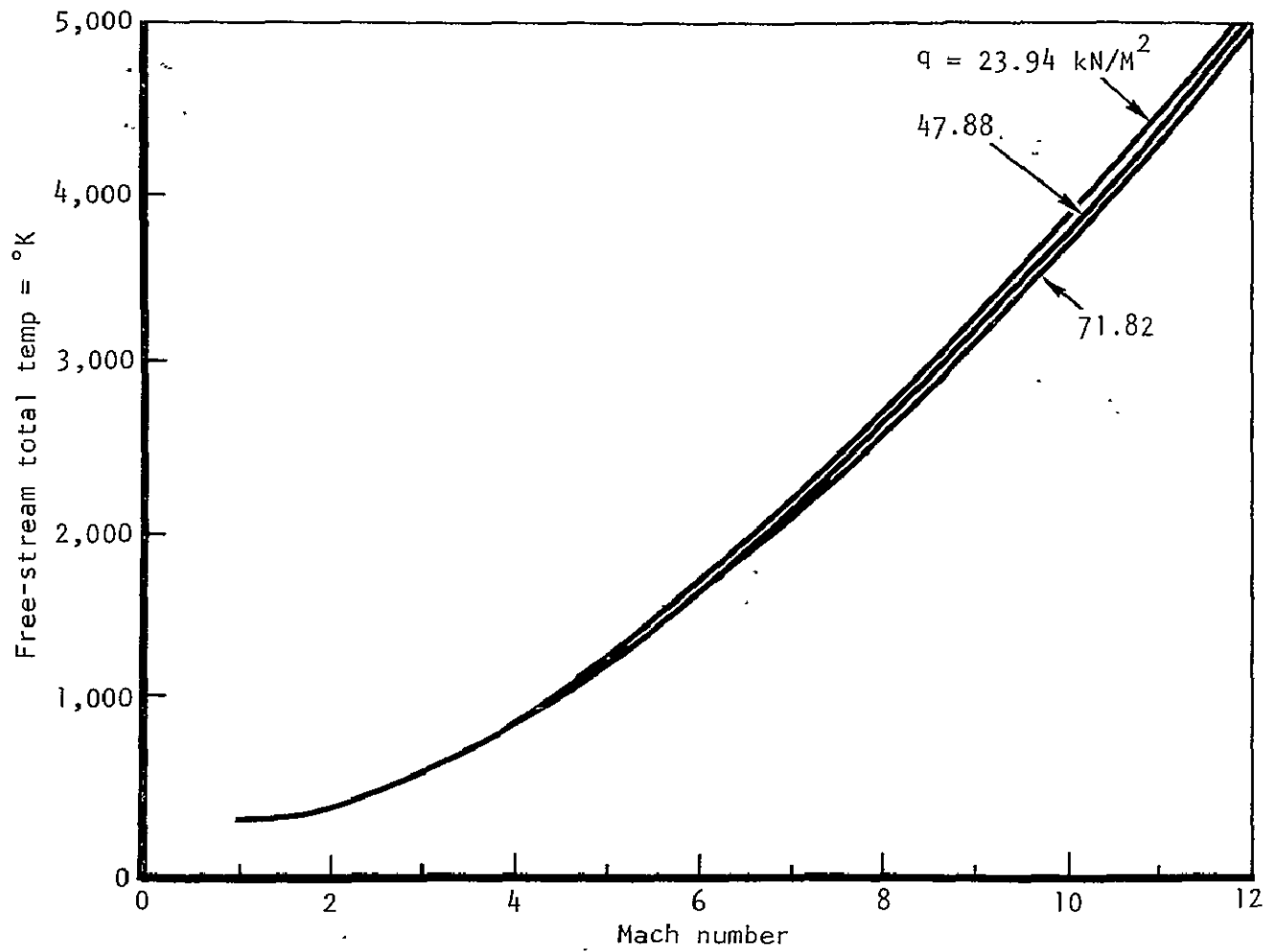
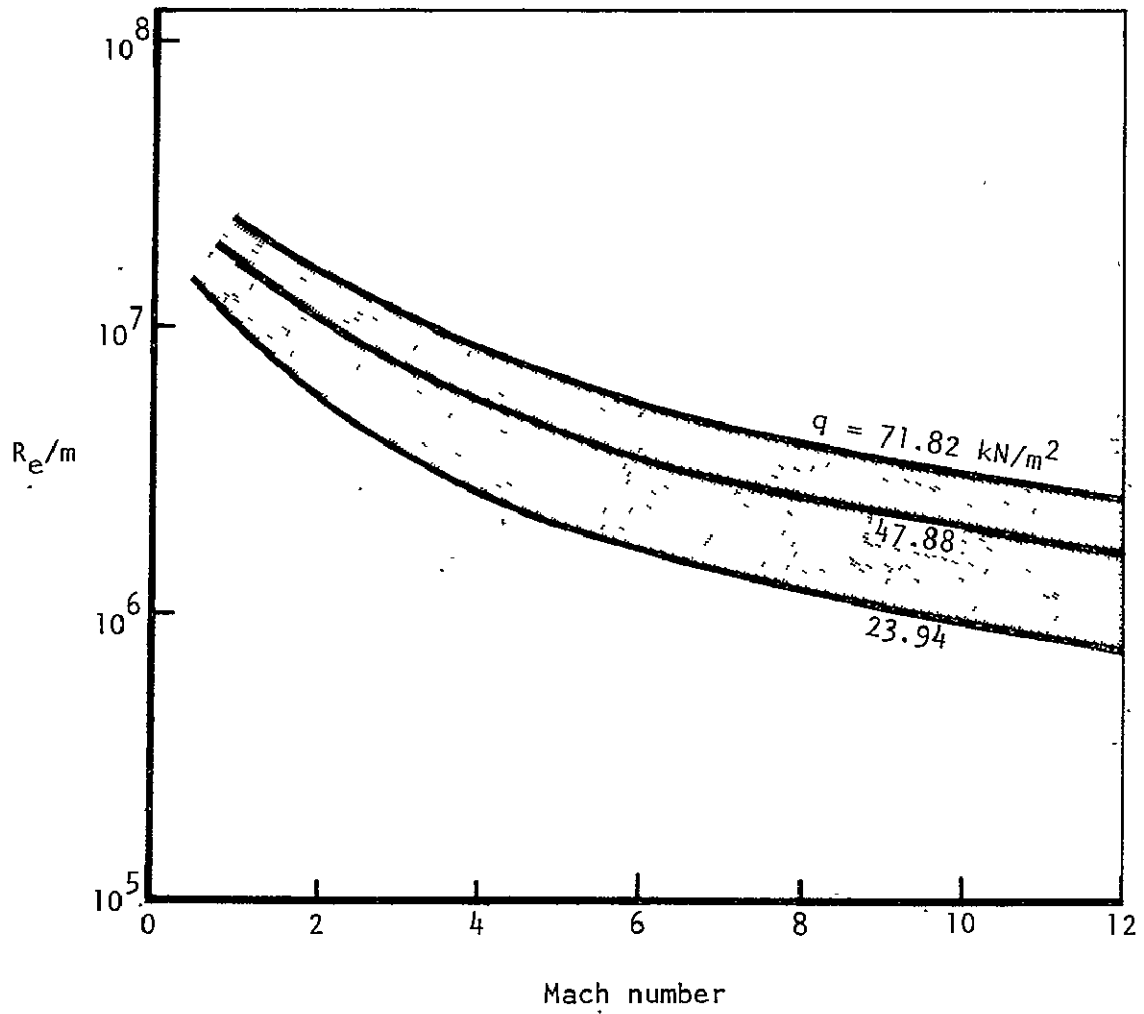

Figure 5. - Free-stream total temperature in flight corridor.



ORIGINAL PAGE IS
OF POOR QUALITY

Figure 6. - Free-stream Reynolds number per meter in flight corridor.

Secondly, the major components of integration, the inlet and nozzle are designed and developed to satisfy the requirements of the engine and at the same time operate under environmental and geometric restrictions that are imposed by the airframe design. Conversely, the airframe design and performance is altered to strike a compromise with the inlet and nozzle design.

Third, an iteration is required to assure that the desired vehicle performance is achievable with the revised configuration and integrated performance.

And finally, tests are conducted to provide design criteria data and to validate performance predictions.

These steps may not follow in rigid succession, particularly since iteration is the fundamental tool for optimization of the design. Also, independent development of airframe, inlet, engine, and nozzle components relies heavily on testing. Thus, component development can, and often does, precede the design integration process.

This approach (for supersonic aircraft) is characterized by concentration on a number of localized integration design problems. The total integrated vehicle performance is then the summation of the performance of the individual nonintegrated components plus performance increments caused by localized interaction effects when the airframe and propulsion components are brought together.

The major supersonic integration problem areas have been with distortion and unsteadiness of inlet flow, and with nozzle/airframe interference drag and thrust loss (refs. 13 and 14). Experimental techniques have proven to be the best way to solve these problems, both in wind tunnel tests and flight tests. Wind tunnel testing has been helped by development of propulsion simulation techniques. With the engine stream tube properly simulated, airframe/propulsion interaction effects are more easily measured and accounted for.

Extending this general approach to hypersonic scramjet-powered vehicles provides a general outline for integration development. However, the methodology and test techniques must be modified to account for the different characteristics of this class of vehicles. These characteristics include:

- (1) The proportion of vehicle surface associated with the propulsion system rapidly increases with Mach number.

- (2) Scramjet engines produce exhaust gases with complex caloric, chemical, and kinetic characteristics that cannot be simulated with hot air.

(3) Useful engine net thrust is a function of the relatively small difference between large values of inlet and exit stream momentum. This characteristic places a premium on system efficiency with increasing Mach number.

(4) Scramjet fuel mixing and combustion process are not easily scaled for model tests.

(5) Extreme air properties of hypersonic flight are difficult to reproduce in ground testing facilities.

Because of these characteristics, the integration methodology and test techniques of hypersonic vehicles become involved with the entire vehicle. The general integration logic and flow diagram is shown in figure 7. It begins in the initial vehicle design conception, where integration concepts are based on preliminary data. Parallel paths are then followed in the development of airframe and propulsion concepts. These development paths proceed with the initial integration design concepts as guidelines. As more parametric design data become available, integration design concepts are upgraded and the parallel development paths are progressively brought together. In the design integration phase, emphasis is placed on tailoring vehicle design so that the integrated performance is optimized. At this point, it is expected that the new design data generated will suggest some alteration in the initial preliminary design concepts and assumptions leading to better design integration. Therefore, iteration of the development process back through the cycle is repeated. This recycling builds up a parametric design integration base which can then be used to support the design of advanced prototype vehicles.

Design Conception

Before configuration development can proceed, several concepts need to be fixed. The most important of these is the vehicle mission. There needs to be agreement as to what the vehicle is supposed to do, and agreement on the need for the vehicle. This will allow the scope, schedules, and baseline assumptions to be matched to the allocation of resources to the program.

The available data base and generic vehicle development experience is then used to initiate a simple conceptual design synthesis in response to the selected mission. This phase is heavily influenced by previous design studies and establishes in a very preliminary sense, the basic design choices such as engine and fuel type, launch and landing modes, size, speed, and range. With this information, the flight regime can be defined, establishing the atmospheric environment that the vehicle must be designed for.

ORIGINAL PAGE IS
OF POOR QUALITY

Integration
Logic diagram

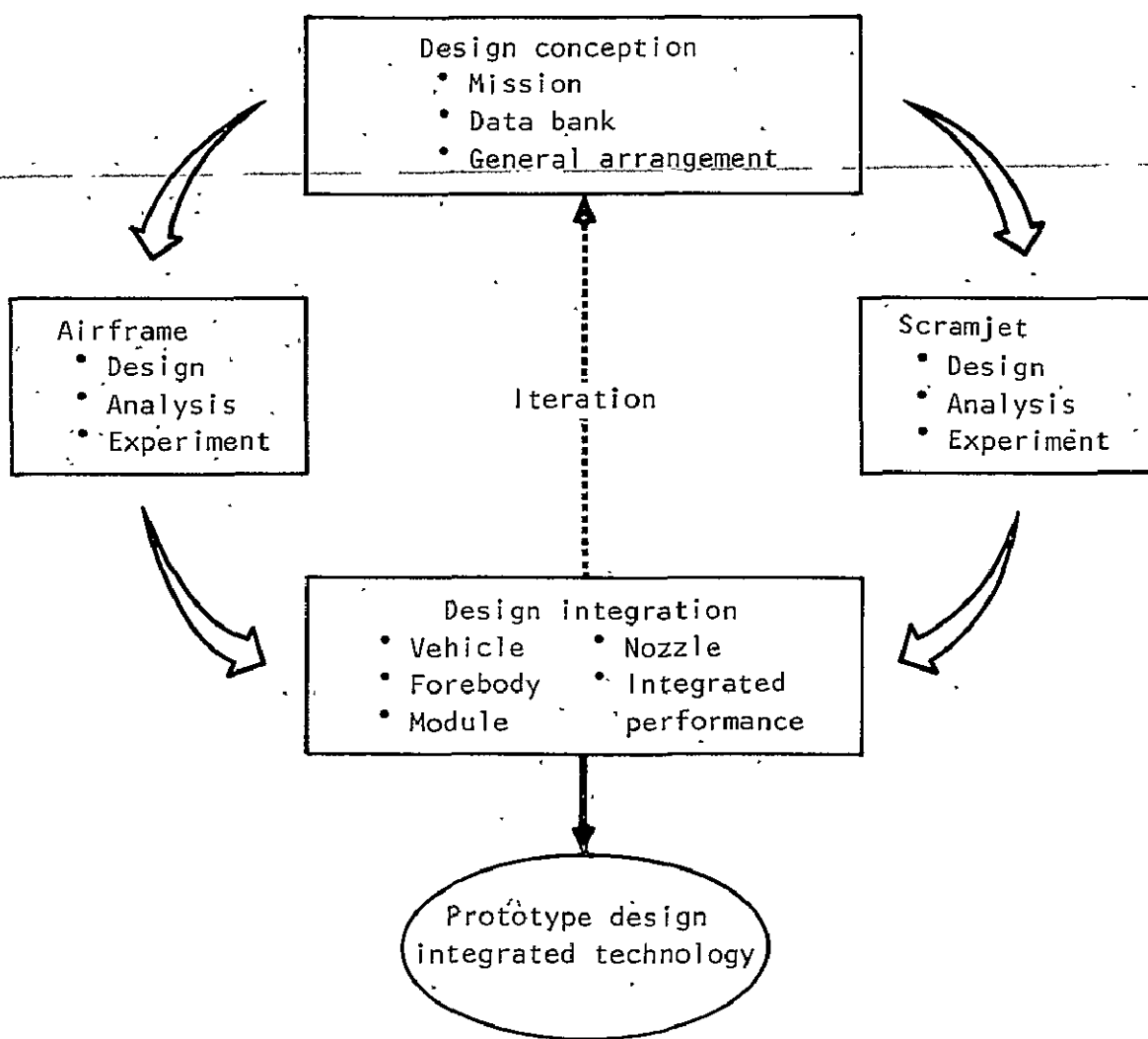

Figure 7. Integration process logic diagram.

A design concept usually evolves in several steps. At each step, the previous design attempts are evaluated, their weak features noted, and new improved features sought. By a combination of phased advances and the weeding out of unsuccessful approaches, a promising design concept is evolved. At the conclusion of this conceptual design phase, preliminary drawings of the vehicle, airframe, and scramjet are required in sufficient detail to furnish a sound starting point for configuration development. Normally, a number of candidate design configurations are prepared, one of which is picked as a baseline. This phase helps uncover the more obvious configurational limitations, and also allows the introduction of innovative concepts at an early stage for further evaluation.

Airframe Configuration

The configuration design trades to maximize L/D over the Mach number range involve the wing and fuselage shapes and sizes. Drag level across the Mach range must be low enough so that the vehicle can be accelerated to the cruise condition. Maximum L/D is desired across the Mach range to obtain maximum range. An adequate L/D is required at low subsonic speed so that a landing maneuver can be safely executed.

These design trades are developed for the hypersonic case, using the Gentry finite-element program to calculate six components of forces and moments, and control surface effectiveness (ref. 15). The Gentry program includes 17 different pressure laws for surface elements facing the flow (impact flow) and 10 different pressure laws for surface elements shielded from the flow (shadow flow). A turbulent skin friction (Spalding and Chi correlations) calculation and an empirical correction for flow separation ahead of deflected control surfaces are included.

In spite of its flexibility, the Gentry program does have limitations. Interference between surface elements is neglected. Directional stability and control are poorly predicted. A useful alternate to the Gentry program is not now available, although a new hypersonic formulation to include interference between surface elements is under development by Rockwell International under NASA/LRC contract NAS1-15075.

Airframe forces and moments must be calculated for both the case with scramjet modules removed and with them in place. The Gentry program can be used to calculate the external forces on the modules, but is not suitable for the module internal flow analysis or the nozzle forces with the modules in place.

Module inlet flow process, forces, and moments can be calculated by the method of Trexler (ref. 16) using a combination of swept shock system analysis

and experimental data. The combustor section of the modules is treated with a one-dimensional analysis for both the cold and hot-flow (combustion) modes, as outlined by Anderson (ref. 17). This simplification permits an analysis to proceed for the preliminary design trade studies of the airframe. A more detailed analysis is described in the parallel development path of the scramjet.

Similarly, the nozzle flow-field forces and moments are calculated using a one-dimensional streamtube procedure to obtain preliminary design trade information using, for example, the procedure of Talcott and Hunt (ref. 18). Calculations using the Gentry program should be made almost continuously during the configuration development cycle from initial concept to prototype go-ahead. In the early stages attention should be directed toward basic design and performance. In the later stages, propulsion integration refinements and special problems should be emphasized.

~~Supersonic and subsonic design trades are developed using linear finite-~~ element distributed panel programs, as for example, Bonner, Clever, and Dunn (ref. 19), to calculate six components of forces and moments, and control surface effectiveness. The available distributed panel programs use constant strength vortex panels for lift and quadratically varying source panels for thickness.

At subsonic speeds, the vortex lattice programs can be used when applicable and are more efficient, being less expensive to run. Development of an improved distributed panel program is underway at Boeing under contract to NASA/Ames but it is not yet available for general use (ref. 20).

Hypersonic scramjet-powered vehicles tend to have relatively low aspect ratio wings with high leading-edge sweep and, in the case of the NHFRF vehicle, a relatively large body. These vehicles tend to display nonlinear lift and pitching moment curves associated with vortex shedding from the sides of the fuselage and from the leading edges of the wing. Although some progress has recently been made toward a theoretical calculation of these nonlinear effects (refs. 21 and 22), it still remains true that they are best determined by experiment, particularly at low subsonic speeds.

A Mach 6 cruise vehicle that is accelerated to the cruise condition either by rocket or by turbo-ramjet will usually have some blunt base area. Although some limited success has been achieved using Korst and related base pressure calculation techniques (ref. 23), it is still generally true that pressures on blunt bases are best determined experimentally and adjusted for small geometry changes.

Landing gear and deceleration device drag increments are generally based on measurements on similar configurations. Adjustments for fineness ratio, deflection angle, and projected frontal areas are made when appropriate.

Total skin friction has an effect on overall lift/drag and thrust/drag ratio. The relative importance of total skin friction on these ratios at supersonic and hypersonic speeds depends upon configuration fineness ratio and wave-drag levels. Probable ground tests will include force and moment measurements in wind tunnels on subscale models with boundary layers tripped and turbulent at low supersonic Mach numbers but with boundary layers untripped and partially laminar and transitional at high supersonic and hypersonic Mach numbers. Probable extrapolation from ground-to-flight test condition will include a calculation of total skin friction at both conditions and an adjustment of drag level and C_{D_0} (drag coefficient at zero lift). Implied in this procedure is the assumption that drag-due-to-lift does not change appreciably with boundary layer type. Except in those cases where substantial separation is involved, this procedure is generally regarded as adequate in an engineering sense. Wing leading-edge separation and vortex effects will be mentioned here because, for some leading-edge radii and leading-edge sweep angles, a decrease in drag-due-to-lift with an increase in Reynolds number has been observed and attributed to suppression of leading edge separation and vortex effects and an enhancement of leading edge thrust as Reynolds number is increased (ref. 24). This effect is probably restricted to subsonic and low supersonic speeds. Neglect of this effect is conservative from an (L/D) and (T/D) standpoint except, possibly, for those configurations which use vortex induced lift, moment, and drag for maneuver advantage. For example, if vortex induced lift, moment, and drag are used during the landing maneuver, insurance that this effect is present, full-scale would depend upon a suitably large, possibly full-scale, subsonic test.

The importance of blunt-base pressures on (L/D) and (T/D) depends on the ratio of blunt-base area to total frontal area. Blunt-base pressures measured in subscale wind tunnel tests are generally used to adjust measured forces and moments back to a preselected reference pressure, such as free-stream ambient pressure. In the determination of blunt-base pressures for full-scale flight condition, subscale wind-tunnel data are frequently ignored. Blunt-base pressures in flight are usually based on flight-test measurements on a similar configuration or on a correlation based on flight measurement. Mach 6 cruise vehicles boosted to cruise speed by rocket have relatively large blunt-base areas. Those boosted to cruise speed by a turbo-ramjet multimode system have relatively small blunt-base area. For those configurations having blunt-base area more than 10 to 15 percent of the total frontal area, a preprototype research vehicle would contribute significantly to the definitions of (L/D) and (T/D). For configurations having smaller blunt-base areas, this effect obviously is less and may be negligible.

Most current layouts for Mach 6 cruise vehicles show low hingeline sweep angles of horizontal control surfaces (elevators), and moderate to high sweep of vertical control hingelines. For low-to-moderate hingeline sweeps, flow separation ahead of deflected control surfaces is expected to reduce control effectiveness somewhat. A substantial effect on maneuver and trim ability will occur, and a limiting effect on (L/D) and (T/D) may occur. A significant increase in local heat transfer rates near the reattachment line on control surfaces can also be critical. The largest scale supersonic and hypersonic measurements of control surface effectiveness should be extrapolated to full scale using available semiempirical correlations (ref. 25),

Wind tunnel and flight test experimental data are used to back up the theoretical calculations. Wind tunnel tests are conducted using scale models to obtain both force and pressure data. Continuous flow facilities are available to cover the speed range from subsonic through Mach 6. The models can be tested alternately with cold-flow modules and without the modules attached. Testing with scramjet combustion represented requires special consideration, which is discussed in a following section.

Projection of subscale model data to full-scale flight data requires the following steps:

- (1) Model force balance data must be corrected for balance cavity pressures, internal module drag (for application of propulsion forces), tares of the support system and model modifications to accommodate the support system.

- (2) Corrected model drag must be adjusted from model to flight scale Reynolds number by using the appropriate boundary layer skin friction and viscous corrections.

- (3) Full-scale drag must be corrected for those items that were not included for simulation on the model (excrescence, protuberances, roughness) using empirical/analytical techniques.

- (4) Full-scale aerodynamic performance must be corrected for propulsion/airframe interactions not fully simulated in model tests.

Step (1) requires careful bookkeeping of forces and good model design to avoid unnecessary and extraneous conflicting forces. An alternate plan is to test with a pressure model. This measurement scheme places a large number of pressure orifices on the model to obtain a direct pressure/area integration, bypassing the need to apply balance, cavity, and other tare corrections. The disadvantage is that complex pressure distributions with large gradations are difficult to track with a reasonably finite distribution of orifices.

ORIGINAL PAGE IS
OF POOR QUALITY

Step (2) model drag correction is concerned primarily with the friction drag included in the subscale force model data. A ΔC_D is obtained by extrapolating model friction drag to flight using the Reynolds number as correlation. Useful data for defining this extrapolation is obtained from flight tests and from specialized wind tunnel tests in which the Reynolds number can be varied over a wide range. In this extrapolation, care must be exercised in handling the influence of transition. Attempts to induce artificial transition on the subscale models at hypersonic speeds has not proven successful because of the disproportionately large trips required. Thus, the usual procedure is to use trips on the models only at the subsonic through low-supersonic speed regime. At hypersonic speeds, the wall to stream temperature ratio exerts an increasingly strong influence on the boundary layer characteristics. Thus, an additional extrapolation is required for this parameter correction.

Step (3) drag increments are obtained by adapting test data collected on configuration details that can be related to the full-scale vehicle.

Step (4) is usually exercised in specialized separate tests of the propulsion system alone, and with propulsion simulated in conjunction with the airframe. This step is discussed more fully in a following section.

Scramjet Configuration

The scramjet simply consists of an inlet, fuel injector, combustor, and exhaust nozzle. An airframe integrated scramjet utilizes the airframe forebody as an inlet precompression surface. The airframe aft body is used as an extension of the nozzle expansion surface. Fuel injection and combustion take place in compact modules placed in a near midposition on the body. Additional inlet compression surfaces are built into the entrance of the modules. Fuel injectors are built into these surfaces. Mixing and combustion are initiated inside the module passages. Thermal and chemical processes of the reaction continue through the module.

This propulsion concept permits some development of the modules independent of the vehicle, since the modules themselves contain the basic components of engine operation; inlet, injectors, combustor, and nozzle. This requires that the ambient flow properties forward and aft of the modules correctly simulate the environment found on the vehicle. Isolated module development is particularly useful for the refinement of the internal configuration, since test facility size and airflow requirements are considerably less than needed for test of a complete integrated engine.

ORIGINAL PAGE IS
OF POOR QUALITY

The module mixing and combustion characteristics form the base on which the engine development is built. The methods of analysis and experiment used are reviewed, for example, in ref. 6, 17, and 26. Of relevance for the purpose of integration technology is that there is a strong coupling between the air-flow properties entering the modules (velocity, pressure temperature, and chemical state) and the design and performance of the fuel injection, mixing, and combustion system. These parameters dictate, to an important degree, the mixing and reaction lengths needed and, thus, module length.

Also, in turn, the gas-flow properties exiting from the modules have a strong influence on the expansion surface resultant forces and interactions on the vehicle. The high-heat addition in the combustor leads to formation of dissociated products, absorbing thermal energy. Recombination and release of this thermal energy in the nozzle expansion is delayed in typical configurations, and a portion of the thermal energy for conversion to thrust is unavailable. This leads to very complex calculation and experimental methods for analysis of the nozzle design and performance. As input to this analysis, the module exit gas-flow thermal, kinetic, and chemical states must be known.

For purposes of force accounting, the scramjet modules are considered to be the engine. Fuselage forebody and aftbody surfaces, although contributing to the propulsion system operation, are accounted as airframe forces. In conjunction with separate development of the modular engine, it is useful to separate out those forces directly associated with the modules. These forces are then linked parametrically to the vehicle forebody and aftbody design for overall integrated vehicle performance analysis. Module forces include:

- (1) Additive drag
- (2) Spillage cowl drag
- (3) Module external drag
- (4) Net module thrust

Additive drag is the force exerted in the thrust direction on the stream tube of air entering the inlet of an air breathing engine by the surrounding atmosphere. The mathematical expression is obtained by summing the x-direction forces algebraically and setting them equal to the x-direction change in momentum. This requires a knowledge of the shape of the captured stream tube and the pressure distribution along its boundaries. The displacement effect of the body boundary layer must also be accounted for. A combination of numerical calculation and experiment can be used to define these characteristics. At subsonic speeds, numerical methods such as the Douglas Neumann program can be used to calculate the flow field characteristics.

This analysis loses applicability, however, as α and ψ are increased, introducing strong 3-D flow effects. Experimental data must then be relied upon. Details of the structure of this flow at the inlet can be calculated for the supersonic case by analysis of the swept shock modification of the flow field. Experimental measurements on wind tunnel models can be used to facilitate and support the analysis, as in the work of Trexler, ref. 16. Care must be exercised in making the distinction between additive drag force and the aerodynamic forces on the vehicle forebody. Since the additive drag is defined as a propulsion force, it must be accounted for separately from the airframe. At certain flight conditions, particularly subsonic, the vehicle forebody will be subject to a combination of forces so that measurements will be needed with and without the modules.

The inlet designs currently considered for application to integrated hypersonic vehicles feature swept sidewall planar compression surfaces with openings upstream of the cowl leading edge through which air can be diverted for starting and operation at low Mach number.

Spillage cowl drag is the force associated with the pressures and friction acting upon the external portions of the inlet cowl lip. The spillage cowl drag offers the mechanism whereby some of the additive drag can be counter balanced. Turning the spilled flow back toward the stream direction can result in some pressure reduction on the forward facing cowl surface. The requirement for low drag at hypersonic speeds, however, generally dictates low cowl angles, which do not permit much additive drag cancellation at lower speeds. The lip shape is generally made up of forward-facing planar wedge elements with small radius leading edges. The external cowl forces can be calculated using tangent wedge theory or other more sophisticated numerical techniques, which also account for the leading edge bluntness and the nonuniform approach flow. Difficulty in this analysis comes with 3-D end effects, shock coalescence, and boundary layer separation.

The forces can also be determined experimentally by means of pressure/area integrations, or by force measurements on metric model sections.

The module external drag includes all the friction and pressure drag on the external surfaces of the modules, excluding the spillage cowl drag which normally is accounted separately. In the accounting of all forces, the forces acting on the vehicle surface masked by the modules and nozzle must be removed. Module drag can be predicted using the same numerical procedures outlined for the vehicle.

Experimental verification of the drag predictions can be made with wind tunnel tests of models. In these tests, the module mass flow must be controlled to simulate the correct spillage.

ORIGINAL PAGE IS
OF POOR QUALITY

The net module thrust is defined as the increase in momentum of the airflow leaving the module compared to the momentum entering the module. It is convenient to include the internal nozzle surfaces as part of the module so that the exit momentum is defined at the exit of the internal nozzle.

The net module thrust is of importance, also, for the cold-flow case (no combustion), and is a net module drag. In the cold-flow case, the module internal flow process can be calculated from theoretical swept shock diagrams at supersonic and hypersonic speeds. Corrections for boundary layer ingestion and internal viscous effects are not amenable to direct numerical analysis, and are handled empirically with inputs of experimental data. The aerodynamic testing of scramjet inlets and modules has demonstrated a fair correlation between predictions and measurement of the net internal module force. Momentum surveys at the module inlet and exit are useful in defining the measured performance, although there is difficulty in obtaining complete surveys.

~~At subsonic speeds, experimental data offers the only useful technique~~ for prediction of the internal drag. Stream-tube numerical calculation computer programs may be used to provide some guidance in the prediction, but the dominating viscous effects and asymmetric flow patterns inside the modules add considerable complications.

In the hot-flow case, fuel injection and combustion modifies the internal flow patterns, forces, and exit flow momentum. The development of the internal configuration tends to be independent of external conditions. That is, the development of the inlet, fuel injection, and combustor can proceed in isolation if the ambient inlet and exit flow characteristics are specified. The integration of the scramjet engine module with the airframe, as far as net module thrust is concerned, considers only the net force and how it is influenced at the inlet and exit by the ambient external conditions. In fact, the modular approach for the engine has been adopted so that development on these critical items can be concentrated.

Design criteria and prediction techniques for the internal hot-flow process have been developed for the scramjet module. The inlet process can be predicted by calculation with empirical adjustments for viscous effects. Fuel injection and mixing is understood from a simplified theoretical basis, but must rely on experiment and empiricism to account for finite pattern overlapping, 3-D flow, and viscous effects. Combustion is related to the mixing process, the enthalpy level of the air and the chemical kinetics of the flowing system. All of these processes and relationships can be analyzed theoretically on a one-dimensional basis. Calculations on a 3-D basis have not yet been fully developed. Empirical analysis and design procedures are relied on to predict the combustion process.

Testing of hot-flow scramjet modules provides the best means of development, but this procedure is handicapped by a number of difficulties. First, provision of high Mach number, high enthalpy air at the inlet to simulate flight requires large energy sources. Second, the mixing/combustion process is not directly scalable to small model sizes, thus requiring large test rigs and large energy sources. Third, the exit gas composition, energy mode, and thermal kinetic characteristics are difficult to measure because of the high enthalpy conditions prevailing, and because of the rapidly changing conditions in the flow. These difficulties have been the subject of much research and development of test techniques and procedures. Module hot-flow testing has been conducted in shock tunnels, arc-heated tunnels, and stored energy blow-down type wind tunnels. Measurement techniques used include direct force measurement, entering and exiting stream thrust measurement, and an internal force accounting summation including drag of fuel struts.

The nozzle/afterbody is designed to provide a relatively large area for expansion of the module exhaust gases to recover a large portion of the system thrust potential. The configuration shape is developed by optimizing the thrust, drag, and moment characteristics over the vehicle speed range. This requires that the gas flow process and resulting reaction on the body be predictable for all the operating conditions.

The accurate prediction of the exhaust flow fields requires the consideration of the following:

- (1) 3-D flow field effects, including multiple shock interaction and expansion fans
- (2) Interaction with the external flow
- (3) Finite-rate chemical reactions
- (4) Boundary layer effects
- (5) Nonuniform flow properties
- (6) Heat transfer from high temperature, i.e., to cooled surfaces

No single analytical technique exists which includes all of the above phenomena. However, computer programs exist for the prediction of the inviscid 2-D and quasi 3-D exhaust flow properties, including real gas effects which can be used for parametric studies and preliminary design.

The prediction of 3-D flow field effects is felt to be very important due to the strong interaction between the multimodule scramjet flow fields and the external flow. The outer module flow will be most strongly affected due to

lateral flow expansion, and possible interaction with the lateral control surfaces of elevons. The detailed analytical solution of this 3-D flow problem is very difficult. Consequently, for parametric and preliminary design purposes, simplified quasi 3-D methods are used (refs. 28, 29 and 30).

Finite rate chemical reactions.- The state of the exhaust gas during the expansion process significantly affects afterbody forces. For example, a 33-percent change in normal force can result between frozen and equilibrium flows, and a corresponding change of about 7 percent in the axial force.

None of the existing computer programs for scramjet exhaust simulation include finite rate chemistry. However, one-dimensional stream tube analyses, reported in ref. 31, indicate that the exhaust gas, for $M = 6$ to 8 flight conditions, is essentially frozen.

Boundary layer effects.- External flow boundary layer effects are primarily limited to the mixing/shear layer development at the exhaust/external flow interface. Afterbody pressures are relatively unaffected since Mach lines originating at the slip plane will generally not reach the afterbody surface except those from the outer sidewalls. The nozzle/afterbody and module divider boundary layers are expected to have only a secondary influence on the afterbody surface pressures.

Nonuniform flow properties.- The exhaust flow field prediction starts at the combustor exit where the flow is assumed to be uniform in terms of composition and thermodynamic properties. The actual flow properties at the combustor exit will show significant property gradients due to inlet boundary layer ingestion, wall cooling, fuel injection, mixing, and nonuniform combustion. No analytical means exist for the assessment of these spatial property variations on nozzle/afterbody performance.

Wall heat transfer.- Heat transfer between the hot gas and cold structural surfaces affects the boundary layer development and, hence, Mach wave propagation at these surfaces. However, since boundary layer effects on afterbody forces are of secondary nature, heat transfer effects are not considered critical.

Exhaust flow field analysis computer programs.- The following computer programs are presently in use for scramjet flow field properties predictions:

(1) Quasi-3-D characteristics programs using the reference plane technique described in refs. 28 and 29. The multiple-scramjet module configuration is represented by an equivalent single module preserving all area ratios. Thermodynamic properties are input in the form of table lookup for either frozen or equilibrium flow conditions.

(2) 2-D shock capture/floating shock fitting technique (ref. 32), programs used for the detailed prediction of flows with multiple embedded shocks (mostly useful for inlet/strut multiple-shock interaction flow field predictions).

(3) 2-D real gas, shock capture computer program for scramjet flow field analysis (ref. 33). The program computes internal and external flow fields with multiple-shock interactions. Forces and moments due to stream thrust and surface pressure are computed by the program. A special-purpose, hydrogen-air, thermodynamic properties subprogram is used to compute either frozen or chemical equilibrium properties during flow field computation.

(4) 2-D method of characteristics program of ref. 34. Includes NASA/Lewis thermodynamic properties program to generate appropriate gas property tables internally.

Results obtained by these analytical methods may be verified by experiment to establish the validity of the final design.

Nozzle test techniques.- Basic isolated nozzle testing is conducted with a model in which the nozzle test gas is brought on board from an external supply source. It is ejected from the nozzle at conditions simulating the scramjet module exit flow. The module inlet is replaced with a fairing. Portions of the model forward of the nozzle are included and contoured to simulate the module external flow characteristics in an approximate sense. Cold air can be used for the test gas, but the expansion characteristics on the nozzle can be markedly different from the actual products of combustion of the scramjet.

This method of testing can be useful for determining the effect of systematic changes in nozzle geometry on an incremental basis, but is unsuitable for obtaining absolute force levels that can be extrapolated to flight (ref. 34).

An improvement of this test method involves the use of a specially formulated simulant gas instead of the cold air. This results in a better match of the desired nozzle pressure distributions without actually having to reproduce the scramjet combustion process in the model. It has been found that certain mixtures of Freon and argon gases can provide good simulation without the need for high temperatures (ref. 35). An example of the simulation effectiveness of these mixtures compared with air has been calculated using the method of ref. 33, and is presented in figure 8. Additional analysis and

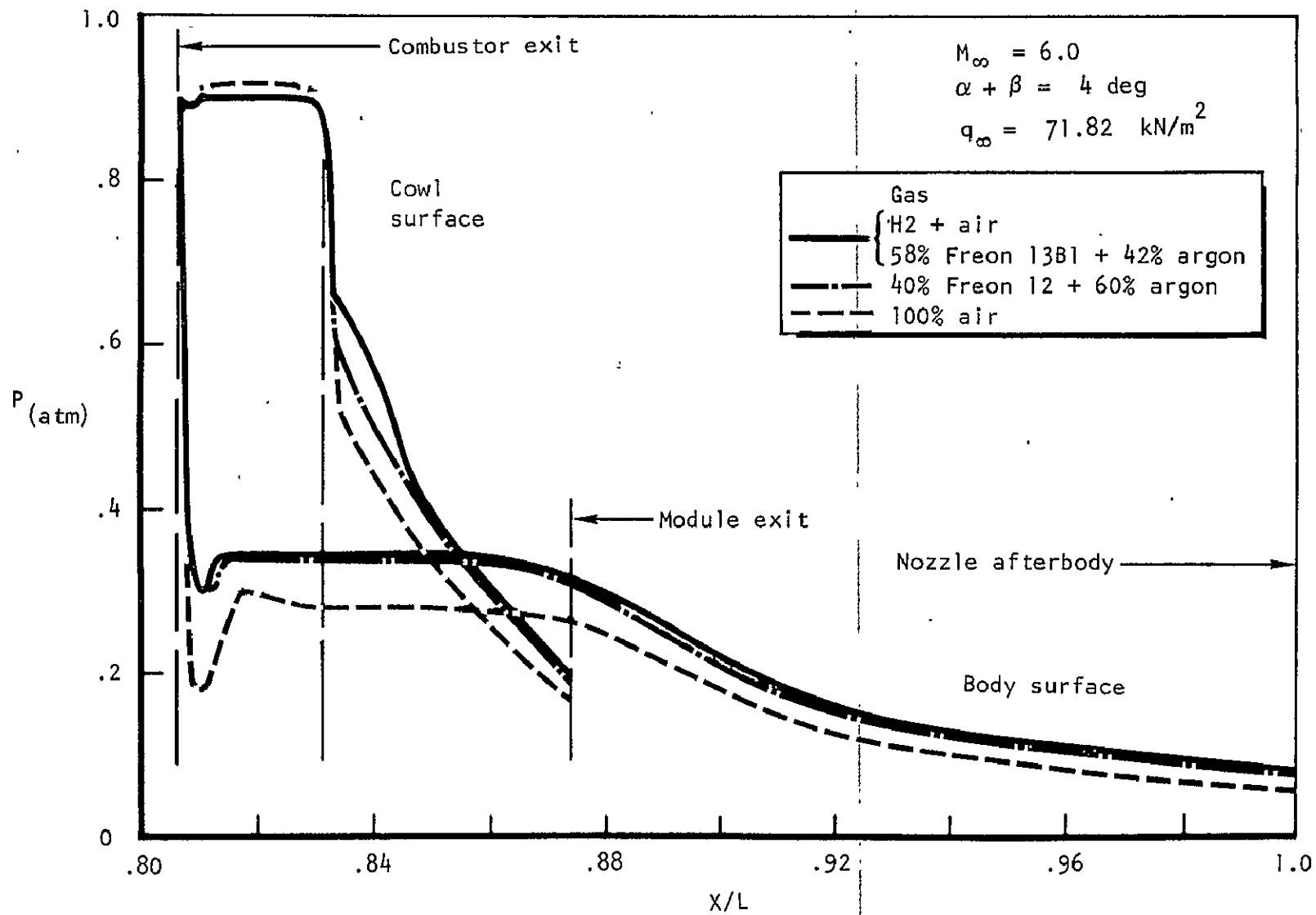

Figure 8. - Exhaust gas simulation effectiveness - nozzle surface pressures.

validation of the simulation effectiveness of these gases have been reported by NASA (ref. 31) with the following conclusions:

(1) Small changes in scramjet exhaust plume thermochemistry can produce significant changes in the normal force on the afterbody nozzle.

(2) The scramjet afterbody nozzle flow is essentially frozen.

(3) A detonation tube experimental technique has been used for comparison of substitute gas nozzle flows to "matched" flight nozzle flows with favorable results.

(4) Substitute gas mixtures can accurately track the pressure and, to a lesser extent, the heat-transfer distributions of scramjet nozzle flows with and without shocks.

However, the simulation effectiveness has been based on analytical correlations and it has not been established that these are fully representative of conditions in a flight scramjet nozzle expansion. Flight tests, or full simulation in a ground test, are needed to fix these correlations. One of the more important parameters needing analysis is the effect of nozzle test model scale. Although critical similarity parameters appear to be matched, it is not clear how the inclusion of viscosity, incomplete mixing, and combustion and thermal conductivity effects will alter the scaling.

Adaptation of the simulant gas test technique to configuration development of the integrated vehicle requires a relatively complex test procedure using several reference models. Such a procedure is described in ref. 36. The difficulty with this approach is that the faired inlet introduces nonideal flow field simulation adjacent to and interacting with the nozzle flow. Also, the indirect force accounting system required tends to degrade the precision of performance measurement. These effects are discussed in a following section.

A nozzle expansion surface can also be tested behind a "hot" hydrogen burning module. Such a scheme is shown schematically in figure 9, taken from ref. 37. The subscale module (1/3 to 1/2 scale of a research aircraft module) is mounted at the exit of a free-jet Mach 6 nozzle. External flow scrubs three sides of the module, but facility size limitations prohibit accurate flow simulation maintenance over the module. The nozzle extension is subject to tare windage forces on the body side, which must be accounted for in the force analysis since the system performance is measured by a net-force direct measurement. Refinements of this scheme might include larger relative nozzle size and tailoring of the external flow around the model by

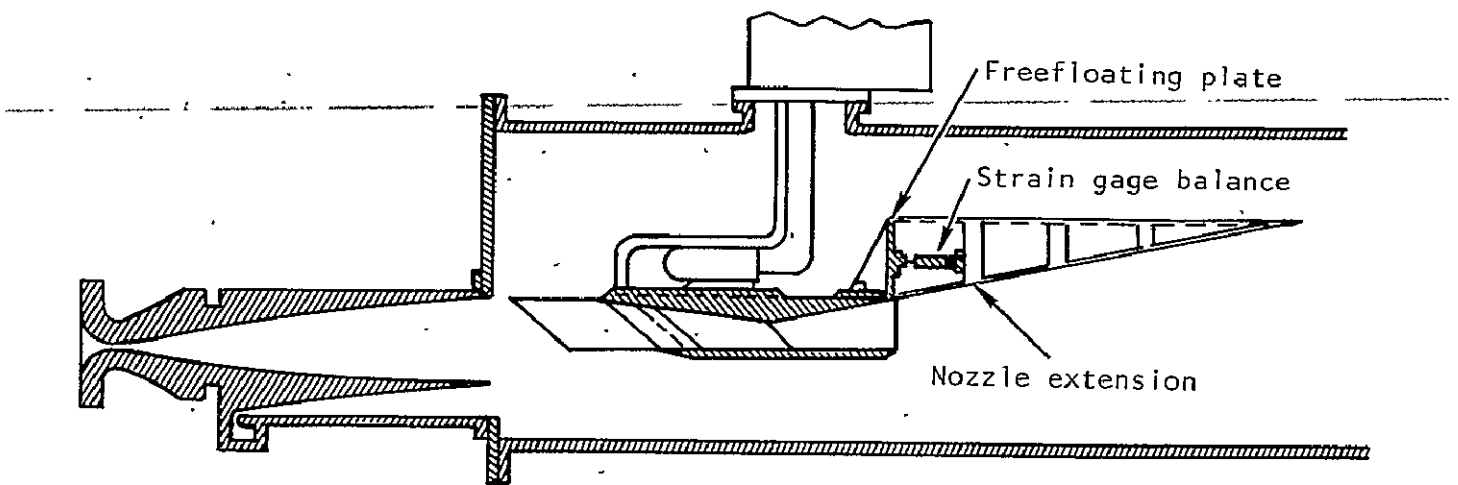

(Ref. 37)

ORIGINAL PAGE IS
OF POOR QUALITY

Figure 9. - Concept for testing with nozzle extension bolted to rear portion of engine to evaluate engine plus nozzle internal drag and thrust.

means of jet stretchers and porous walls. This approach can provide useful simulation and data on the localized flow characteristics at the combustor exit and the primary nozzle surface. Interaction effects with the external airflow, however, would be dependent on how well the external flow was simulated. Inclusion of more of the vehicle forebody and other surfaces close to the modules and nozzle would improve the simulation but require larger test facility size.

Design Integration

It was noted earlier that during conceptual design and development of airframe and propulsion concepts, preliminary mutual accommodation between the two was anticipated and planned for. Now with more detailed parametric design data generated on airframe and propulsion concepts, a more complete blending and optimization can proceed. Attention can be focused on a closer matching of configuration functions and analysis of interactions.

Figure 10 points out those areas of vehicle configuration that are involved in the blending, sizing, and optimization process. The primary considerations are:

- (1) Design forebody to meet aerodynamic, engine inlet, and vehicle volumetric requirements
- (2) Avoid spillage and interference drag
- (3) Size scramjet to meet mission requirements
- (4) Design nozzle afterbody for thrust, stability, and low trim drag
- (5) Design airframe to give lift, drag, and stability characteristics

Matching of the scramjet and airframe configurations involves a design blending process using the available component parametric data. This means that the scramjet is sized and positioned on the airframe according to the combined predicted lift, thrust, drag, and moment characteristics, and the best match of these predictions with the design goals. The process requires a good knowledge of the component characteristics and a good understanding of the initiatives that can be taken with the configuration.

For example, the best fore/aft location of the modules depends primarily on a trade-off between forebody inlet design and the nozzle aftbody design. Secondary considerations in this trade-off include, for example, how the airframe camber and lift/drag are affected. These interface sensitivity studies are performed using the component parametric data to work toward an optimum.

(a) Design forebody to meet aerodynamic, engine inlet, & vehicle volumetric requirements.

(b) Avoid spillage & interference drag

(c) Size scramjet to meet mission requirements

(d) Design nozzle aftbody for thrust, stability, & low trim drag

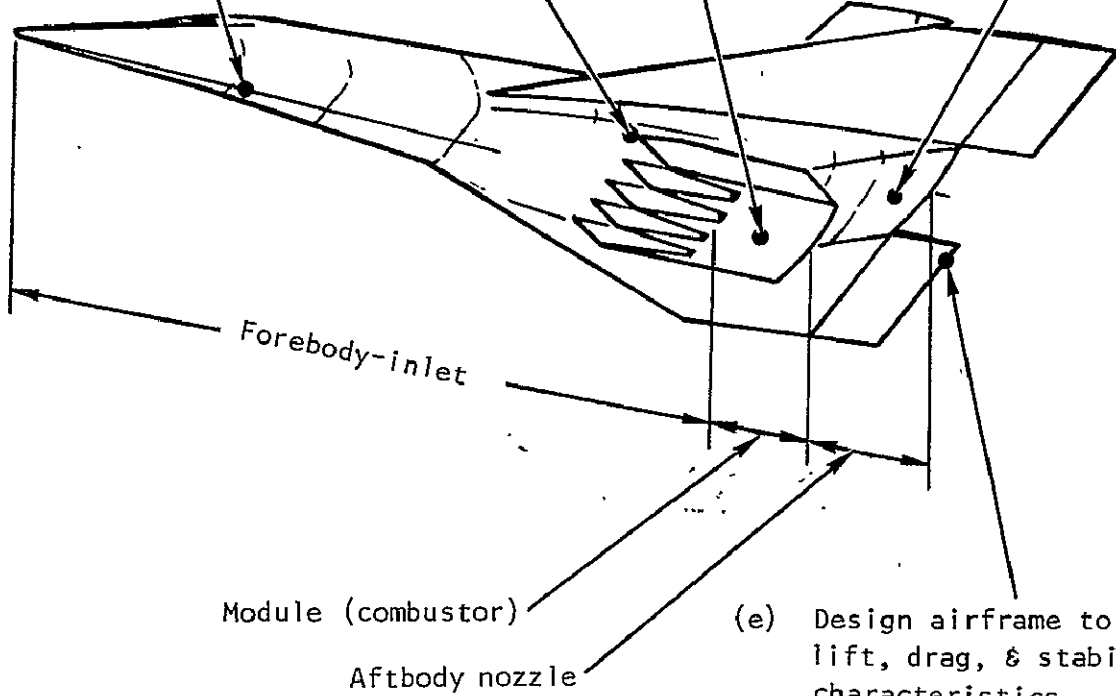

**ORIGINAL PAGE IS
OF POOR QUALITY**

Figure 10.- Primary integration design considerations.

At this stage, mutual interactions between components and between flow fields must be given special attention. These interactions and synergistic effects can have an important additive or subtractive effect on the integrated performance. The following effects are to be identified and accounted for:

- (1) Interfering 3-D flow fields
- (2) Viscous phenomena
- (3) Surface shielding
- (4) Shock impingements

External flow characteristics over and around the sides of the modules are determined by the interaction of the forebody flow field and the inlet geometry. Inlet flow spillage adds to this interaction. The resulting complex 3-D flow field is not amenable to theoretical calculation except for simplified approximate solutions. Instead, experimental data is relied upon to analyze this flow and evaluate the resulting forces.

Interactions occur between the module external flow and the nozzle exhaust plume. This interaction is also difficult to analyze theoretically. Simplified quasi 3-D methods can be applied (refs. 28 and 29), but these are not considered to be sufficiently comprehensive. Experimental measurements of the local flow fields must be made. Testing of configurations with these interacting flow fields correctly simulated is necessary for a realistic assessment of integrated performance.

In order that the relationship between design integration and viscous phenomena be understood, it is instructive to review the more general influence of viscous effects on the following listed vehicle design and performance characteristics:

- (1) Overall lift drag ratio with scramjet modules off
- (2) Overall lift drag ratio with scramjet modules on but open to cold through flow
- (3) Overall thrust/drag ratios with scramjet modules on and with hot-jet flowing
- (4) Trim and maneuver ability and overall moments with scramjet modules on and either with hot-jet flowing or with cold-through-flow

A listing of the relevant viscous phenomena is presented in table I. Possible flow separations affecting surface pressures and skin friction that can affect lift/drag ratio, thrust/drag ratio and maneuverability are due to:

- (1) Sharp edge at a blunt base
 - (2) Extreme (high-angle) afterbody boattailing
 - (3) Shocks in streamwise corner flow
 - (4) Flow deflection due to jet plume
 - (5) Subsonic flow past sharp inlet lip
 - (6) Module transonic choke
-
- (7) Deflected control surface

Probable ground testing includes subscale wind tunnel tests with modules on, with cold through-flow, with simulant gas exhaust, and with modules off. For extrapolation of separation effects to full-scale flight conditions, the subscale test data can be used unaltered, or adjusted using empirical or semiempirical correlations. For modules off and on, with cold through-flow, nozzle afterbody pressures are subject to separation due to the typically large afterbody angles. The magnitude of this effect on L/D depends upon the extent of the separation and the pressure changes due to separation.

Subscale wind tunnel measurements of afterbody pressures are often influenced by the presence of a model sting. Extrapolation of these measured afterbody pressures to full-scale flight involves, first, the removal of the sting influence and, second, adjustment for Reynolds number change. A separate strut-supported model may be required to evaluate the sting influence. At high subsonic Mach numbers and for some boattail shapes, the Reynolds number effect on boattail drag has been shown to be small over a range of Reynolds numbers based on model length of $2 \text{ by } 10^6$ to $70 \text{ by } 10^6$ (ref. 39). Use of the largest scale test data available unaltered to flight conditions, is the best procedure for afterbody separation. It would be desirable if these test data were available on a full-scale research vehicle.

Another anticipated interference concerns supersonic and hypersonic flow along the corners formed by the module sidewalls and the adjacent fuselage or wing. Interacting shocks in the flow along the corner can cause separation with either laminar or turbulent boundary layers. A large increase in local heat transfer and skin friction is known to occur along the reattachment line (ref. 41). The overall effect on L/D, T/D, and maneuver, however, is likely to

TABLE I. - LISTING OF VISCOUS PHENOMENA

<u>Viscous phenomena</u>	<u>Affects</u>
Boundary layer formation on vehicle external components	- Total skin friction
Boundary layer and inviscid flow ingested by Scramjet	- Mixing and combustion
Boundary layer formation along module inner walls	- Mixing and combustion
Vortices, shear layers, and eddies shed from fuel injection struts and also due to fuel injection	- Mixing and combustion
Vortices and shear layers shed from module divider walls at combustor exit	- Nozzle and plume expansions
Plume boundary layer formation along nozzle afterbody	- Nozzle afterbody scrubbing friction
Blunt base mixing and separation	- Blunt base pressure
Afterbody separation	- Afterbody pressures
Corner flow boundary layers and separation (due to corner flow shock interactions)	- Pressures and skin friction near corner
Plume-induced separation on wing and Scramjet module	- Pressures and skin friction on wing and module
Inlet lip internal or external separation (at subsonic speed)	- Pressures and skin friction on wing and module
Separation due to module choked flow (at transonic speed)	- Pressures and skin friction on wing and module
Separation ahead of deflected control surfaces	- Pressures and moments due to control surface

ORIGINAL PAGE IS
OF POOR QUALITY

be small because the region affected is small with respect to the total wing area and located not far from the center of gravity. Subscale wind tunnel test measurements including this effect should be made and used, unaltered, at flight condition.

External flow along the module and wing near the scramjet exhaust will be deflected outward by the under-expanded jet at the model exit. This plume-induced flow deflection can produce a flow separation which changes surface pressures on the modules and wing and alters T/D trimmed. On a full-scale vehicle and with turbulent boundary layer, the extent of the separation and the area affected are expected to be relatively small. On a small, subscale wind-tunnel model with simulant gas exhaust, the external flow boundary layer may be laminar at the module exit and, the extent of the separation and area affected, larger. Enough probing should be done prior to flight to establish if this effect on T/D is significant. Extrapolation to flight conditions should be based on updated semiempirical correlations, using the most recently available computer tools. A full-scale research vehicle measurement of this effect would reduce uncertainties in prototype design.

Subsonic flow past an inclined sharp inlet lip is known to produce lee-side flow separations from the lip which, for inlet leading edge sweeps of 50 degrees or greater, quickly form the cores of downstream running vortices. The magnitude of this effect on L/D depends upon the resulting pressure increments and on the area affected below the wing. Based on the relatively small amount of wing area affected, the overall effect on L/D is expected to be small. The effect should be checked on the largest scale, subsonic wind tunnel test to be conducted.

If the scramjet modules remain exposed during acceleration through the transonic speed range, a shock pattern will pass over the modules as the cold through-flow goes from subsonic to supersonic. At some transonic Mach number, while the modules are still choked, a normal shock ahead of the modules may cause the flow to separate from the surfaces of the fuselage and approach ramps. The result will be that the module will remain choked to a higher supersonic Mach number than without separation. This has a significant effect on D and L/D at transonic speed. Increased energy will be required to accelerate to unchoked supersonic speed.

The completeness of mixing and combustion inside the modules has a first-order effect on thrust/drag ratio. Viscous phenomena affecting mixing and combustion include boundary layer ingested by the scramjet, boundary layer formed along module inner walls, and vortices, shear layers, and eddies shed from fuel injection struts. Probable ground testing includes high-enthalpy, large-scale, short-duration tests of single modules with a simulation of the ingested boundary layer. The matching of flight Mach numbers, total temperatures, and total pressures will insure that Reynolds numbers are matched as

well. The resulting viscous phenomena will be the same as in flight except for possible mismatch in wall temperature and amount of ingested boundary layer. Extrapolation to flight conditions should consider effects of these mismatches on module thrust.

Surface pressures and skin friction on the nozzle afterbody have a first-order effect on thrust/drag ratio, and on trim and maneuverability. Viscous phenomena which affect the nozzle expansion include wakes, vortices, and shear layers shed from the module divider walls at the combustor exit, vortices and shear layers shed from the nozzle end plate, and plume boundary layer formation along the scrubbed afterbody.

The effects of wakes and shear layers shed from the module divider walls cannot be adequately evaluated in single-module tests, therefore, nozzle afterbody processes and forces should be measured in ground test with both single and multiple modules. Reynolds number effect on these viscous phenomena should be determined for correlation with full-scale flight performance.

Measured nozzle pressures can be integrated to give the nozzle pressure force. This can be compared with balance-measured nozzle force to give a measure of the plume boundary layer skin friction. A more frequently used procedure is to calculate the nozzle skin friction force using the measured pressures for reference. The skin friction force must then be corrected to flight Reynolds numbers.

The design integration process strongly relies on a useful force accounting system to keep the bookkeeping organized. The close relationship and dual roles played by airframe and propulsion components of the hypersonic vehicle emphasize this need. The relationships are outlined in figure 11.

The airframe forces are defined with the engine scramjet modules removed. The forces acting on the surfaces normally subtended by the inlet, modules, and nozzle are not included, and must be removed or replaced with an ambient pressure area term. The vehicle forebody is not considered a part of the inlet surface. The nozzle surface is considered to be that part washed by the engine exhaust. Engine forces are defined with the engine in place on the vehicle and with the vehicle flow field environment established. Interference forces are defined as corrections to the airframe forces generated by the imposition of the inlet, nacelle, and nozzle to the airframe. The accounting system is primarily a guide to prevent the double accounting or loss by oversight of some of the forces. Modifications to the accounting system are normally made to adapt to the specialized testing techniques that are necessary in the integration development.

ORIGINAL PAGE IS
OF POOR QUALITY

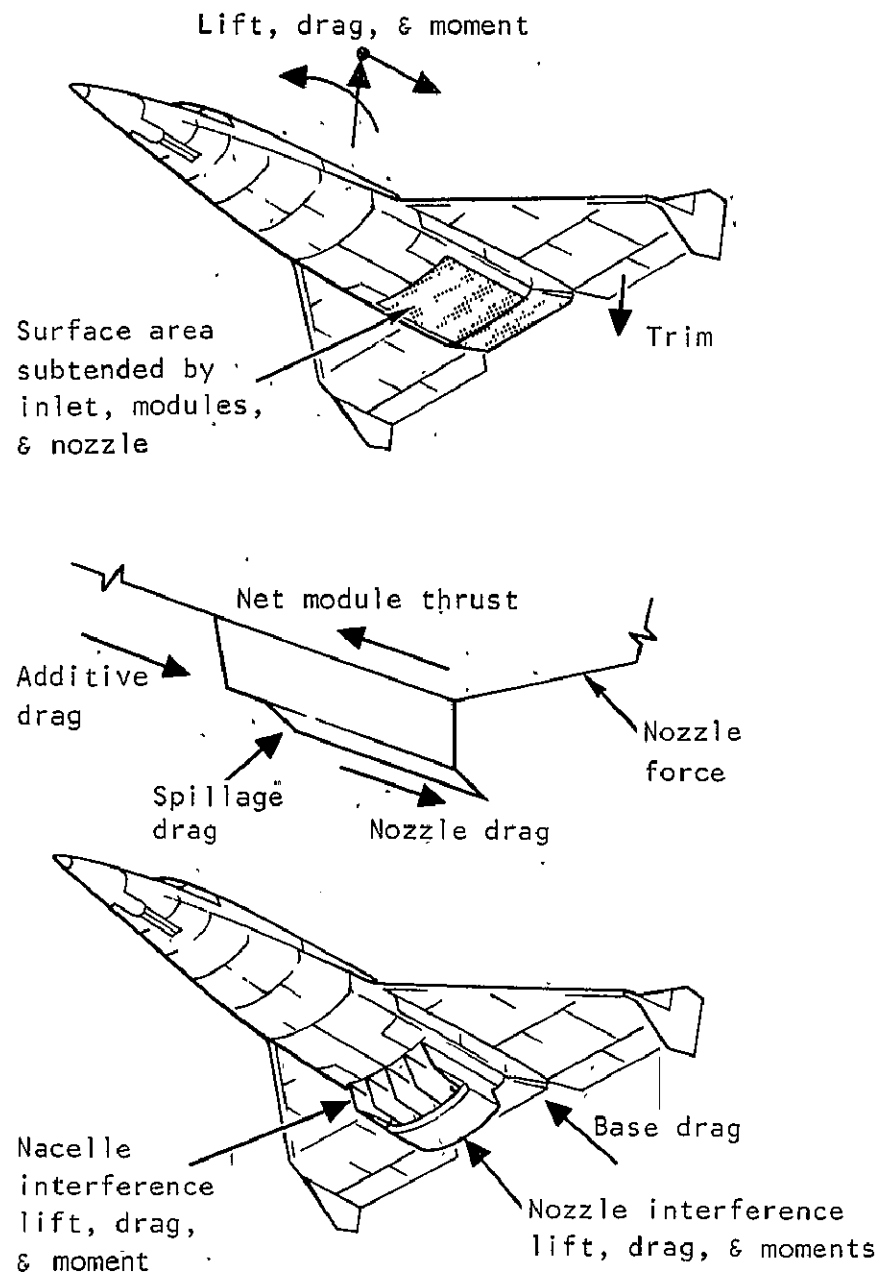

Airframe forces (No engine)

- Vehicle lift, drag and moment (no engine)
- Forces generated on surface area subtended by inlet, modules, & nozzle are removed
- Trim forces

Engine forces (with airframe environment)

- Inlet/combustor net thrust & moment
- Additive drag
- Spillage drag
- Nacelle drag (external)
- Nozzle thrust, lift, and moments

Interference forces (airframe force increment)

- Nacelle interference forces
- Nozzle interference forces
- Base drag increment

Figure 11. - Basic force accounting.

At this stage of integration development, the configuration elements and parametric data are used to synthesize an optimum design. The synergistic effects are accounted for, and tests of integrated configurations are conducted to validate the integration effects. If the evolving configuration results in undesirable features and/or performance, an iteration is performed. This iteration back through some or all of the previous steps is repeated until an acceptable optimum is reached.

A proof test of the integrated optimum vehicle configuration is needed at this point to validate the design process. This is normally a flight test of a complete vehicle. In this case, an operating scramjet engine system would be required. Net performance would be measured directly and diagnostic measurements taken for analysis of integration characteristics.

Substitution of a ground or flight test of a suitably modified generically similar vehicle might be acceptable depending on the degree of simulation achieved. The flight test validation would generate correlation data for use in supporting application of ground-based design and performance criteria. The data base would be upgraded for direct support of the prototype development program.

INTEGRATION TECHNOLOGY MILESTONES

A series of milestones can be defined, consistent with the foregoing description of methodology and test techniques, to measure progress. These milestones are directed at the development of airframe/propulsion technology, and indicate work that is needed that would permit a decision for construction of a prototype aircraft. A milestone is understood to be an important event that shows progress and can signal completion of a basic development phase, an analysis and/or an experiment. Five primary and 21 secondary milestones have been identified and listed in table II.

Milestone Description

1.0 Complete conceptual design.- A general outline of the vehicle concept will be prepared. This will set the type of vehicle, propulsion required, and purpose of the vehicle.

1.1 Mission.- A flight mission is selected from candidates using national priorities as criteria. Preliminary flight path, speed, launch, land, and control modes are selected.

ORIGINAL PAGE IS
OF POOR QUALITY

TABLE II. - INTEGRATION MILESTONES

1.0 Complete conceptual design
1.1 Mission
1.2 Parametric conceptual analysis
1.3 Conceptual drawing
2.0 Prepare airframe design base
2.1 Airframe aero analysis
2.2 Inlet and module aero analysis
2.3 Airframe and inlet scaling and viscous criteria
2.4 Airframe and inlet performance validation
2.5 Airframe and inlet parametric characteristics
3.0 Prepare Scramjet design base
3.1 Scramjet aero analysis
3.2 Nozzle aero analysis
3.3 Scramjet and nozzle scaling criteria
3.4 Scramjet performance validation
3.5 Nozzle performance validation
3.6 Scramjet and nozzle parametric characteristics
4.0 Complete design integration
4.1 Force accounting method
4.2 Inlet and modules integration
4.3 Nozzle integration
4.4 Integration design optimization
5.0 Validate integrated design criteria
5.1 Predict integrated vehicle performance
5.2 Validate integrated vehicle performance
5.3 Establish design and performance correlation

1.2 Parametric conceptual analysis.- The preliminary mechanical/aerodynamic configuration is developed from the existing data bank. Parametric data are prepared for the synthesis of design/performance trades of candidate concepts.

1.3 Conceptual drawing.- A conceptual drawing is prepared for one or more candidate designs. This serves as a focal point for following detailed configuration development. Configuration generic evolution is used as a starting point. New requirements and technology advances are incorporated as they become available.

2.0 Prepare airframe design base.- The baseline airframe aerodynamic characteristics and performance are established, with parametric data generated to permit trade studies and integration refinements.

2.1 Airframe aero analysis.- Basic analysis methods are established for the design and performance prediction of the airframe.

2.2 Inlet and module aero analysis.- Basic analysis methods are established for the design and performance prediction of the inlet and modules (external nacelle).

2.3 Airframe and inlet scaling and viscous criteria.- Procedures and analysis methods are established for scaling performance and viscous phenomena from model to full scale.

2.4 Airframe and inlet performance validation.- Predicted performance characteristics of airframe and inlet are confirmed through testing and supportive analysis.

2.5 Airframe and inlet parametric characteristics.- Parametric design/performance characteristics of airframe and inlet design base are generated using analysis and tests.

3.0 Prepare scramjet design base.- The baseline scramjet aerodynamic characteristics and performance are established, with parametric data generated to permit trade studies and integration refinements.

3.1 Scramjet aero analysis.- Basic analysis methods are established for the aero design and performance prediction of the scramjet modules.

3.2 Nozzle aero analysis.- Basic analysis methods are established for the aero design and performance prediction of the nozzle.

3.3 Scramjet and nozzle scaling criteria.- Procedures and analysis methods are established for scaling performance and viscous phenomena from model to full scale.

3.4 Scramjet performance validation.- Predicted performance characteristics of the scramjet are confirmed by proof testing and supportive analysis.

3.5 Nozzle performance validation.- Predicted performance characteristics of the nozzle are confirmed by proof testing and supportive analysis.

3.6 Scramjet and nozzle parametric characteristics.- Parametric design/performance characteristics of scramjet and nozzle design base are generated using analysis and tests.

4.0 Complete design integration.- An integrated design is produced which blends the airframe and propulsion components. The design and performance integration criteria are established.

4.1 Force accounting method.- A method is established for properly accounting and summing all forces involved in the airframe/propulsion integration. This method is adjusted where necessary to be compatible with the testing procedures used.

4.2 Inlet and modules integration.- The inlet and modules integration and design interactions are identified and performance methodology established.

4.3 Nozzle integration.- The nozzle integration and design interactions are identified and performance methodology established.

4.4 Integration design optimization.- Parametric design and performance criteria obtained in preceding milestones are used to establish an optimum integrated vehicle design candidate(s).

5.0 Validate integration design criteria.- Verification is obtained by test and with supportive analysis that the integration design criteria is valid.

5.1 Predict integrated vehicle performance.- A performance analysis and flight performance prediction is made of the integrated vehicle.

5.2 Validate integrated vehicle performance.- Tests of the integrated vehicle are conducted that confirm and validate the predicted flight performance.

5.3 Establish design and performance correlation.- Correlations between flight performance and design integration methodology are established.

Key Milestone Technology Risk Levels

The milestones are a measure of progress. Meeting all the milestones assures that the end objective, a technology base that will permit decision for construction of a prototype aircraft, will be accomplished. Precisely how much work or what technology parameters are needed to signify the completion of a milestone cannot be defined with complete objectivity. Judgmental factors must be involved in this determination. The degree of milestone completion is a rating of success that can be predicted for the final goal.

These factors have been assembled to grade the relative importance, current risk level, acceptable risk level, and risk exposure factor of each milestone. The milestones and these estimated factors are listed in table III. Relative importance is graded on a scale from 0 to 100, with 100 the maximum importance factor. Current risk level is an assessment of the current state of the art for that technology milestone. A 100-percent risk is assigned a risk level factor of 0 while a 0-percent risk would rate a 1.0. The acceptable risk level is that factor judged to be acceptable as indicating adequate completion of the milestone.

The risk exposure factor, column (4), is generated by multiplying the technology gap increment (column 3 minus column 2) by the relative importance factor, column (1). The higher this number, the more work is needed on that milestone to reduce the risk to an acceptable level. Inspection of column (4) shows that the greatest risk lies with milestone 5.2, validation of the integration design criteria. The difficulty in experimental verification of vehicle flight performance is the single most critical technology road block.

TEST FACILITY APPLICATION

Current ground test and new ground test facilities, and flight research vehicles can contribute to the advancement of the hypersonic integration technology. However, there are a number of restrictions and limitations associated with these three options. This is best illustrated by listing the capabilities and limitations of these options with respect to meeting the integration technology milestones.

Current Facility Limitations

Ground-based test facilities play an essential role in developing airframe/propulsion technology. This role, however, has been limited by the failure of facility capabilities to keep pace with the needs of

TABLE III. - TECHNOLOGY RISK LEVELS

Integration milestones	(1) Relative importance	(2) Current risk level	(3) Acceptable risk level	(4) Risk exposure factor
1.0 Complete conceptual design	100	0.50	0.60	10
1.1 Mission		.50		10
1.2 Parametric conceptual analysis		.56		4
1.3 Conceptual drawing		.60		0
2.0 Prepare airframe design base	70	.60	.70	7.0
2.1 Airframe aero analysis		.67		2.1
2.2 Inlet and module aero analysis		.68		1.4
2.3 Airframe and inlet scaling and viscous criteria		.60		7.0
2.4 Airframe and inlet performance validation		.62		5.6
2.5 Airframe and inlet parametric characteristics		.60		7.0
3.0 Prepare Scramjet design base	70	.55	.70	10.5
3.1 Scramjet aero analysis		.63		4.9
3.2 Nozzle aero analysis		.60		7.0
3.3 Scramjet and nozzle scaling criteria		.55		10.5
3.4 Scramjet performance validation		.56		9.8
3.5 Nozzle performance validation		.58		8.4
3.6 Scramjet and nozzle parametric characteristics		.55		10.5
4.0 Complete design integration	90	.60	.80	18.0
4.1 Force accounting method		.79		0.9
4.2 Inlet and modules integration		.65		13.5
4.3 Nozzle integration		.60		18.0
4.4 Integration design optimization		.60		18.0
5.0 Validate integrated design criteria	100	.50	.85	35.0
5.1 Predict integrated vehicle performance		.85		0
5.2 Validate integrated vehicle performance		.50		35.0
5.3 Establish design and performance correlation		.85		0

hypersonic vehicle technology. A survey of existing ground-based United States test facilities was made together with a selection of the most appropriate ones for matching to the milestone requirements. This survey is summarized in table IV. These facility data will be referred to in the following discussion of the milestones.

1.0 Complete conceptual design.-

1.1 Mission.- No test facility required.

1.2 Parametric conceptual analysis.- No test facility required.

1.3 Conceptual drawing.- No test facility required.

2.0 Prepare airframe design base.-

2.1 Airframe aero analysis.- No test facility required.

2.2 Inlet and module aero analysis.- No test facility required.

2.3 Airframe and inlet scaling and viscous criteria.- This milestone is primarily involved with analytical development of procedures and methods for scaling airframe viscous characteristics to full scale. In support of the analytical work, experimental data will be needed to determine boundary layer state, transition characteristics, separation criteria, and scalability of these phenomena. Test model configurations need not be exact geometric representations of the full-scale vehicle as long as data are obtained on classes of configurations such as forebodies, wings, control surfaces, corner flow, base regions, and combinations of these. Primary parameters to be simulated are Mach and Reynolds numbers. High-enthalpy flow simulation is not a requirement, as, for example, would be required for operation of a scramjet engine.

Candidate facilities (milestone 2.3)

F3	Rockwell International Trisonic Tunnel
F4	McDonnell Douglas Trisonic Tunnel
F7	AEDC VKF A
F8	AEDC VKF B
F9	AEDC VKF C
F10	NASA LRC High Reynolds Number Tunnel
F12	NOL Hypersonic Tunnel
F13	AEDC VKF F
F14	Calspan 48-Inch Shock Tunnel
F15	Calspan 96-Inch Shock Tunnel
F21	Holloman AFB Rocket Sled

ORIGINAL PAGE IS
OF POOR QUALITY

Facility limitations (milestone 2.3).- The largest model that can be tested in a wind tunnel is a function of a number of criteria (ref. 8), which for simplification can be reduced to:

$$L = \frac{\sqrt{C}}{1.3}$$

L = model length
C = test section area

This model length has been used to calculate the maximum Reynolds number capability of each of the facilities listed in table IV. The resulting Reynolds number simulation capability was then compared with the Reynolds number flight corridor of a 30.48m long flight vehicle, as shown in figure 12. A 30.48m vehicle length was considered a nominal representative value.

A number of observations are apparent. For Mach numbers up to 5.0, the best simulation would be with a 94 cm long model in the McDonnell Douglas Trisonic Wind Tunnel (F4) (similar versions of this tunnel are in operation at Lockheed, Boeing, and General Dynamics). Ratio of model-to-flight Reynolds number at $q = 1000$ psf would vary from 1/6 at Mach 1 to 3/4 at Mach 3 and 1/2 at Mach 5. In the Mach 5 to Mach 6 range, the Naval Ordnance Laboratory Hypersonic Tunnel (F12) would provide the best simulation. A 4.17cm long model would match 1/2 the flight Reynolds number at Mach 5 and 1/3 at Mach 6.

Above Mach 6, impulse facilities outperform continuous flow facilities. For example, the Calspan Shock Tunnel (F14), with helium driver gas and 41.7-cm model, can generate 1/2 the flight Reynolds number at Mach 6.5. With a hydrogen driver gas (F15), the flight Reynolds number can be matched at Mach 8. Also, the AEDC Hot Shot Tunnel F (F13), with a 94cm long model can match flight Reynolds number from Mach 7.9 to 10.2.

The Rocket Sled Test Track at Holloman Air Force Base, New Mexico (F21), offers another ground-based test technique with high Reynolds number simulation capability. Model size is currently limited to a length of 127 cm, which permits a flight Reynolds number match from Mach 5 to 8. Although the Holloman Rocket Sled Track is operational and aerodynamic models have been tested, the high- q loads ($q = 2630$ kN/m² max) impose restrictions on model construction and mounting systems.

Reynolds number range of these current facilities is marginally adequate if most or all are used. Also, comparison of data from the different types of facilities, using different instrumentation techniques, different wall-to-stream temperature ratios and widely varying run times require further development.

2.4 Airframe and inlet performance validation.- This milestone requires the performance prediction proof testing of airframe and inlet. Test simulation requirements are similar to those of milestone 2.3 except that less emphasis

TABLE IV. - CURRENT GROUND FACILITIES

Code	Facility	Mach range	Nozzle exit, meters	$L = \sqrt{C}/1.3$, meters	Re/m max $\times 10^{-6}$	Re_L max $\times 10^{-6}$	P_T max KN/m^2	T_T max $^{\circ}\text{K}$	Test time
F 1	NASA Ames 40 x 80	0 - 0.30	12.2 x 24.4	13.10	6.89	90.26	101	333	Continuous
F 2	Rockwell low-speed tunnel	0 - 0.28	2.36 x 3.35	2.16	6.56	14.17	101	320	Continuous
F 3	Rockwell trisonic tunnel	0.1 - 3.5	2.1 x 2.1	1.65	55.78	92.0	758	294	5-70 sec
F 4	McDonnell Douglas trisonic tunnel	0.2 - 5.0	1.22 x 1.22	0.95	196.86	187.0	2 482	380	5-100 sec
F 5	AEDC 16T	0.2 - 1.6	4.88 x 4.88	3.75	24.94	93.51	172	344	Continuous
F 6	AEDC 16S	1.5 - 6.0	4.88 x 4.88	3.75	6.20	30.76	75.8	600	Continuous
F 7	AEDC VKF A	1.5 - 6.0	1 x 1'	0.79	29.86	23.59	1 380	417	Continuous
F 8	AEDC VKF B	6, 8	1.27 D	0.85	15.42	13.3	6 205	750	Continuous
F 9	AEDC VKF C	10	1.27 D	0.85	7.87	6.69	13 808	1083	Continuous
F 10	NASA Langley high Reynolds No. tunnel	6.0	0.305 D	0.21	164.05	34.45	20 680	555	1.5 -10 min
F 11	NASA Langley 20-inch Mach 6 tunnel	6.0	0.51 x 0.51	0.39	34.45	13.43	3 790	555	15 min
F 12	NOL hypersonic tunnel	5 - 10	0.61 D	0.42	164.05	68.90	15 170	1110	0.5 min to continuous
F 13	AEDC VKF F	7.9 - 12.2	1.37 D	0.91	206.70	188.10	58 605	2550	50-200 msec
F 14	Calspan 48-inch shock tunnel	6 - 8, 10 - 12	0.61 D 1.22 D	0.42 0.82	131.24 13.12	55.12 10.76	27 580	1555	12 msec 8 msec
F 15	Calspan 96-inch shock tunnel	8.0	0.61 D	0.42	246.08	103.35	137 900	1000	5.5 msec
F 16	Marquardt jet lab, cell 8	0.8 - 7.6	1.22 D	0.55	-	-	1 482	2780	Continuous
F 17	GASL stored heater hypersonic tunnel	4 - 12	0.31 D 0.7 x 0.7	0.21 0.53	-	-	10 340	3056	1 min
F 18	NASA Langley M7 arc tunnel	7.0	0.27 x 0.31	0.22	16.41	3.61	4 054	2220	30 sec
F 19	AEDC APTU	3 - 6.0	0.61 D 1.07 D	0.42 0.73	16.41	6.89 11.98	20 680	2060	5 min
F 20	Holloman AFB rocket sled track	0 - 8.0	NA	1.28	196.86	251.98	965 300	2780	1 min

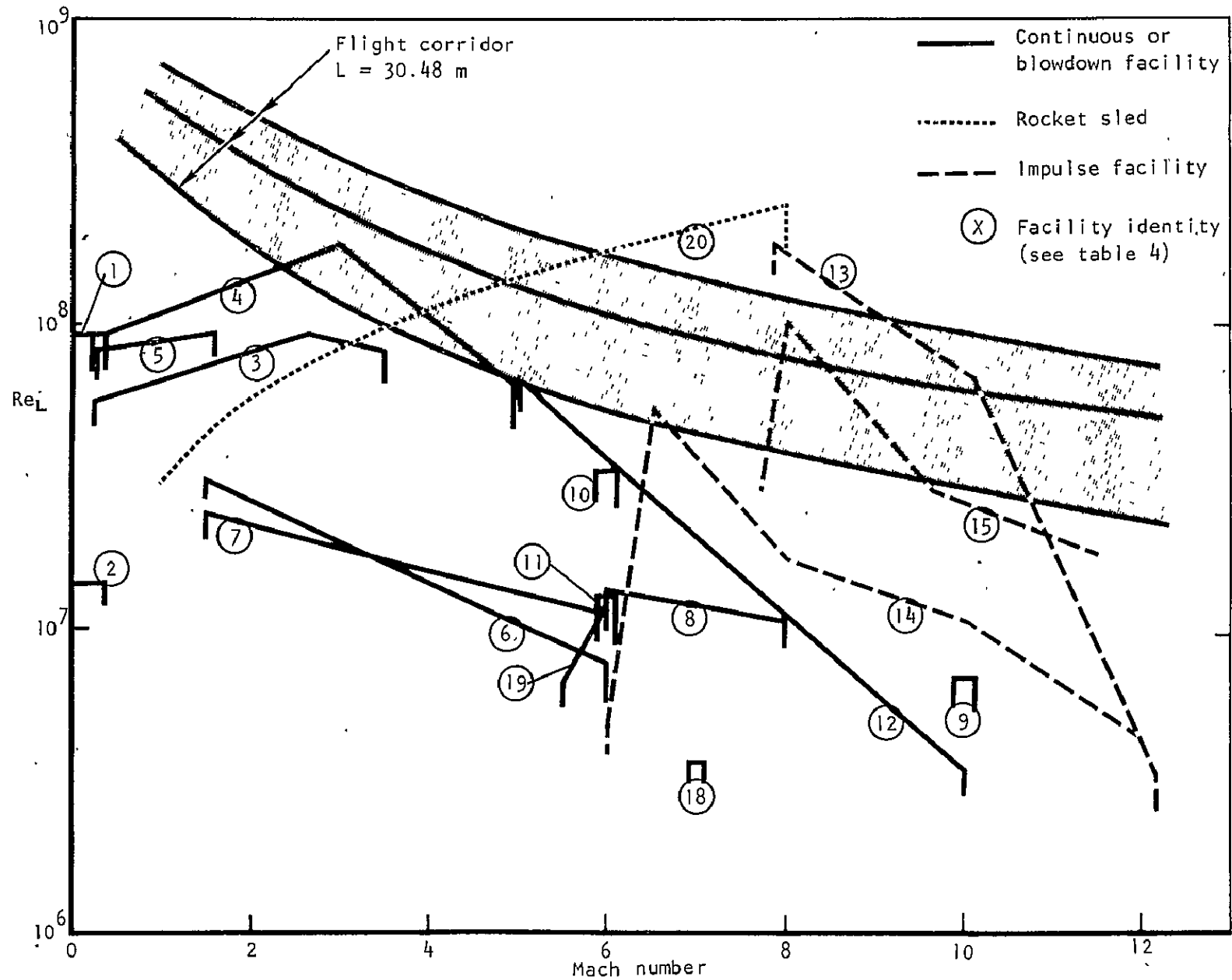

Figure 12. - Current ground-based facility simulation of flight vehicle Reynolds number.

is needed on flight Reynolds number duplication, assuming that a viscous scaling methodology is adequately established. However, a more complete airframe and inlet geometric simulation is required for test. At this stage, the scramjet propulsion system is simulated only in the cold-flow mode (flow-through modules)

Candidate facilities (milestone 2.4)

- F3 Rockwell International Trisonic Tunnel
- F4 McDonnell Douglas Trisonic Tunnel
- F6 AEDC PWT 16 S
- F7 AEDC VKF A
- F8 AEDC VKF B
- F9 AEDC VKF C
- F12 NOL Hypersonic Tunnel
- F13 AEDC VKF F
- F14 Calspan 48-Inch Shock Tunnel
- F15 Calspan 96-Inch Shock Tunnel

Facility limitations (milestone 2.4).- Current facilities are marginally adequate, with the assumption that a viscous-scaling methodology is established (milestone 2.3).

2.5 Airframe and inlet parametric characteristics.- This milestone is an extension of the basic tests and analysis conducted for the preceding milestone 2.4. Test conditions of Mach number, angle of attack, and configuration geometry are varied over a wider range.

Candidate facilities (milestone 2.5)

- F1 NASA ARC 40 by 80 Tunnel
- F2 Rockwell International Low-Speed Tunnel
- F3 Rockwell International Trisonic Tunnel
- F4 McDonnell Douglas Trisonic Tunnel
- F6 AEDC PWT 16 S
- F7 AEDC VKF A
- F8 AEDC VKF B
- F9 AEDC VKF C
- F12 NOL Hypersonic Tunnel
- F13 AEDC VKF F
- F14 Calspan 48-Inch Shock Tunnel
- F15 Calspan 96-Inch Shock Tunnel

ORIGINAL PAGE IS
OF POOR QUALITY

Facility limitations (milestone 2.5).- Current facilities are marginally adequate, with the assumption that a viscous-scaling methodology is established (milestone 2.3).

3.0 Prepare scramjet design base.-

3.1 Scramjet aero analysis.- No test facility required.

3.2 Nozzle aero analysis.- No test facility required.

3.3 Scramjet and nozzle scaling criteria.- Theoretical analysis of the scaling criteria must be supported by test data. The tests involve the mixing, reaction, expansion, and chemical kinetic processes of the scramjet engine and nozzle. High-enthalpy flows simulating the scramjet flight environment are required.

Candidate facilities (milestone 3.3)

F13	AEDC VKF F
F14	Calspan 48-Inch Shock Tunnel
F15	Calspan 96-Inch Shock Tunnel
F16	Marquardt Jet Lab Cell 8
F17	GasI Stored Heater Hypersonic Tunnel
F18	NASA LRC M7 Arc Tunnel
F19	AEDC APTU

Facility limitations (milestone 3.3).- Current facilities are either too small, too low in enthalpy, or are handicapped by insufficient run time to establish all flow properties and/or make needed measurements. A 30.48-m-long vehicle would require scramjet modules measuring approximately 76 cm deep, 61 cm wide, and 5.8 m-long. A nozzle extension would add an additional 5.5 m to the length.

Ground-testing scramjet modules of this size are currently limited to subscale simulations in direct-connect or semidirect-connect testing modes. This allows a larger scale model insertion in a test facility nozzle than would be possible in the airframe aerodynamic tests of milestones 2.3, 2.4, and 2.5, but it also results in poor external flow simulation over the module and nozzle. For evaluation of the internal scramjet performance and scalability, this external flow defect is not important.

The largest module that can be tested in a modified free-jet nozzle is a function of a number of criteria (ref. 8), which for simplification can be reduced to:

$$A_c = C/2.4$$

$$A_c = \text{Module capture area}$$

$$C = \text{Test section area}$$

Thus, a test section area of 1.12 m^2 would be needed to test a full-scale module (120-cm exit diameter facility nozzle).

In addition to a proper facility size to provide valid scaling criteria, the facility must provide adequate duplication of the flight environment. Scramjet operation is dependent on receiving airflow at the pressure, temperature, and velocity, duplicating that found in flight following precompression by the vehicle forebody. Current facilities capable of generating this flow are compared in figure 13 on the basis of the maximum-scale module that they can accommodate.

The small research facilities, such as the NASA Langley Scramjet Facility (F18) and the Gasl Pebble Heater Blow Down Tunnel (F17), have a module size test limit of about 7-percent of full scale. Modules this size have been tested and empirical formulae developed which indicate that mixing dominates combustor scaling criteria (ref. 37). The details of the scaling criteria remain to be defined, however. Development of an even smaller operational module would be useful, but first, large-scale tests are needed to base the scaling criteria.

The AEDC APTU facility (F19) currently offers the best module testing capability. Module scales of 0.26 to 0.80 are possible in the 61- to 107-cm-diameter facility nozzles. This is a blow-down facility with relatively long run times available. Test gas is clean air up to a Mach number of 6.0. Testing can be extended to Mach 8 with vitiated air heated to 3330° K. Vitiating, however, can introduce quantities of water vapor and other compounds which could have an adverse influence on the scramjet combustion process. The Marquardt Jet Laboratory Cell 8 (F16) offers similar operating characteristics but with reduced performance. Clean air is limited to 510° K so that the test range of interest, Mach 3 to 6, must be heated by vitiating. Smaller scramjet combustor modules have been tested in impulse facilities, but experience is lacking in the techniques of maximizing module test size in these facilities. The practical problems of testing a 76-cm-high module, 5.8 m long in an impulse facility have not been investigated.

This milestone (3.3) also requires development of scaling criteria for the scramjet nozzle. Addition of the nozzle to the module, by means of a simplified 2-D representation, is one approach. This method requires a careful tailoring of the external flow around the module and nozzle. Current attempts to accomplish this have met with uncertain results (ref. 37).

An alternate approach (ref. 42) is to generate the module exit gas independent of the external flow, in a hydrogen-air burner and duct this gas to a simulated module exit, for flow over a nozzle surface. External flow must still be provided for reasonable simulation and interaction with the nozzle plume, but this flow could be at a lower enthalpy level than required for flight corridor duplication. This technique is currently available, with some modification of existing facilities, but no experience has been developed in its application.

3.4 Scramjet performance validation.- The operating characteristics and thrust level of the scramjet module must be proof tested.

Candidate facilities (milestone 3.4)

F13	AEDC VKF F
F14	Calspan 48-Inch Shock Tunnel
F15	Calspan 96-Inch Shock Tunnel
F16	Marquardt Jet Lab Cell 8
F17	Gasl Stored Heater Hypersonic Tunnel
F18	NASA LRC M7 Arc Tunnel
F19	AEDC APTU

Facility limitations (milestone 3.4).- Same limitations as listed for milestone 3.3.

3.5 Nozzle performance validation.- The nozzle thrust and moment characteristics must be measured in tests with a correct representation of module effluent and external flow present. For these tests, the effluent can be either represented by an actual scramjet combustion process or by a simulant gas (ref. 35).

Candidate facilities (milestone 3.5)

F14	NOL Hypersonic Wind Tunnel
F6	AEDC PWT 16S
F11	NASA LRC 20-Inch Mach 6 Tunnel
F12	McDonnell Douglas Trisonic Tunnel
F13	AEDC VKF F
F14	Calspan 48-Inch Shock Tunnel
F15	Calspan 96-Inch Shock Tunnel
F16	Marquardt Jet Lab Cell 8
F17	Gasl Stored Heater Hypersonic Tunnel
F18	NASA LRC M7 Arc Tunnel
F19	AEDC APTU

Facility limitations (milestone 3.5).- For tests with an actual scramjet combustion process generating the nozzle effluent, facilities F13 through F19 would be applicable but undersized for adequately maintaining correct flow to a minimum-sized module and nozzle. Also, these facilities are not large enough to test multiple modules for investigating intermodule wakes and interactions.

The use of smaller scale models with multiple modules would be possible using the simulant gas technique, permitting a better fit of the nozzle in all the listed facilities. However, the reduction in Reynolds number would be undesirable. Acceptable Reynolds number testing limits for the nozzle have not yet been defined. These are subject of milestone 3.3.

3.6 Scramjet and nozzle parametric characteristics.- The scramjet module and nozzle must be tested over a wide range of conditions; Mach number, temperature, pressure, and geometric variables, to confirm parametric performance characteristics. Conceivably, module and nozzle could be tested separately if interface properties are correctly simulated. Viability of this option has not been confirmed.

Candidate facilities (milestone 3.6)

- F4 NOL Hypersonic Tunnel
- F6 AEDC PWT 16S
- F11 NASA LRC 20-Inch Mach 6 Tunnel
- F12 McDonnell Douglas Trisonic Tunnel
- F13 AEDC VKF F
- F14 Calspan 48-Inch Shock Tunnel
- F15 Calspan 96-Inch Shock Tunnel
- F16 Marquardt Jet Lab Cell 8
- F17 Gasl Stored Heater Hypersonic Tunnel
- F18 NASA LRC M7 Arc Tunnel
- F19 AEDC APTU

Facility limitations (milestone 3.6).- Same limitations as noted for milestones 3.3 and 3.5.

4.0 Complete design integration.-

4.1 Force accounting method.- No test facility required.

4.2 Inlet and modules integration.- Detailed interactions between inlet/modules and airframe will be identified in tests. This milestone is similar to milestone 2.5 except that greater emphasis is placed on measurement of viscous interaction characteristics, which are heavily dependent on Reynolds number simulation.

Candidate facilities (milestone 4.2)

- F1 NASA ARC 40 x 80 Tunnel
- F2 Rockwell International Low Speed Tunnel
- F3 Rockwell International Trisonic Tunnel
- F4 McDonnell Douglas Trisonic Tunnel
- F6 AEDC PWT 16S
- F7 AEDC VKF A
- F8 AEDC VKF B
- F9 AEDC VKF C
- F12 NOL Hypersonic Tunnel
- F13 AEDC VKF F

ORIGINAL PAGE IS
OF POOR QUALITY

- F14 Calspan 48-Inch Shock Tunnel
- F15 Calspan 96-Inch Shock Tunnel

Facility limitations (milestone 4.2).- Reynolds number simulation capability is limited. See comments on milestone 2.3.

4.3 Nozzle integration.- Detailed interactions between the nozzle and airframe will be identified and measured in tests.

Candidate facilities (milestone 4.3)

- F5 AEDC PWT 16S
- F8 AEDC VKF B
- F9 AEDC VKF C
- F11 NASA LRC 20-Inch Mach 6 Tunnel

Facility limitations (milestone 4.3).- No current high-enthalpy facilities are large enough to test a reasonable simulation of airframe modules and nozzle with functioning scramjet combustion. The alternative for test in a ground facility is to use a simulant gas technique in the facilities listed. The resulting compromises in simulation due to the inlet fairing, reference models, and low Reynolds number, give a "poor" rating to the current applicable facilities.

4.4 Integration design optimization.- No test facility required (requires data input from preceding milestones).

5.0 Validate integration design criteria.-

5.1 Predict integrated vehicle performance.- No test facility required.

5.2 Validate integrated vehicle performance.- Tests of the complete, integrated vehicle must be made to confirm the predicted flight performance.

Candidate facilities (milestone 5.2).- None.

Facility limitations (milestone 5.2). - There are no high enthalpy ground facilities large enough to test an integrated airframe scramjet configuration.

Taking the minimum practical size of a scramjet module as having a height, $h = 20$ cm, and length, $l = 150$ cm (size of the NASA Langley scramjet module, ref. 37), and the relationship of aerodynamic model length to facility test section area as $L = \sqrt{C}/1.3$, we find that a test section area of $C = 108$ m² would be required. It is quite clear that there are no hypersonic flight

corridor simulating facilities that even approach this size (test facility nozzle exit diameter of 11.7 m). The largest applicable facility test nozzles currently available are in the 1.22- to 1.37-m-diameter range (F14 and F13).

If the integrated model were scaled down to fit the criteria for the 1.37 m test facility, the modules would measure $h = 2.34$ cm, and $l = 17.6$ cm. It is considered unlikely that a miniaturization of the scramjet module of this order could be made to operate satisfactorily. This question deserves further study, however, because of the potential advantages that such a device could add to the development methodology.

The simulant gas technique, proposed as an alternate test technique for milestone 4.3, may also be considered for use in achieving this milestone. If this technique is proven suitable, the facility size, as well as the high-enthalpy test gas requirement for this milestone, could be relaxed to match the facility requirements of milestone 2.5. The suitability of the technique for this milestone is believed questionable, however, because of its inability to simultaneously simulate module inlet and exit flows.

5.3 Establish design and performance correlation.- No test facility required (except to provide inputs as noted for preceding milestones).

New Facility Potential

Development of improved new facilities could help overcome the limitations imposed by the current U.S. ground test facilities. A survey of potential facilities was made with respect to their particular usefulness in helping achieve the key technology milestones. This survey included a look at older mothballed facilities, modified current facilities, as well as proposed new facilities. A practical judgmental restraint was imposed on the upper limits of facility size, cost, and energy requirements.

A representative group was selected to demonstrate what improvement might be expected in meeting the milestones. A number of other facility concepts and modifications could be included for consideration, but it is expected that the ones chosen here can be used for extrapolations and comparisons. The finely detailed (HYFAC) study of ref. 8, for example, can be used for additional analysis.

ORIGINAL PAGE IS
OF POOR QUALITY

The facility group chosen for the present study is listed in table V, together with their primary characteristics. The estimated effects of the proposed new facilities on the key integration milestone risk levels and risk exposure factors are listed in table VI. A description of these facilities and their capabilities follows.

Two proposed facilities from the ref. 8 HYFAC study were chosen for an extension of the Mach number, Reynolds number simulation range for aerodynamic testing. NF1 is the proposed HYFAC GD20 intermittent wind tunnel operating from a high-pressure, stored air, blowing down to atmosphere. Two separate channels, a trisonic and a hypersonic leg are provided to cover the Mach range 0.5 to 8.5.

NF1 (GD20) SPECIFICATIONS

	Leg 1	Leg 2
Test section	4.9 m x 4.9 m	3.7 m x 3.7 m
Run time	15 to 60 sec	15 to 25 sec
Mach no.	0.5 to 5	4.5 to 8.5
Stagnation pressure kN/m ²	117 to 2027	1,034 to 16,272
Stagnation temperature ° K	311 to 398	342 to 706
Estimated cost		
(1970)	\$131.7 million	
(1980)	\$225.5 million	

TABLE V. — NEW GROUND FACILITIES

Code	New facility	Mach range	Nozzle Exit, meters	$L = \sqrt{c}/1.3$ meters	Re/m max $\times 10^{-6}$	Re_L max $\times 10^{-6}$	P_T max kn/m^2	T_T max $^{\circ}K$	Test time	Estimated cost \$M, 1970	Estimated cost \$M, 1980
NF 1	HYFAC GD 20 (ref. 8)	0.5 - 5.0 4.5 - 8.5	4.88 X 4.88 3.66 X 3.66	3.75 2.80	98.43 76.56	369.11 214.37	16 550	700	20-60 sec	131.7	225.5
NF 2	HYFAC GD 7 (ref. 8)	8 - 13	3.05 D	2.1	104.99	220.48	124 100	1390	5-10 sec	26.6	45.5
NF 3	HYFAC E9 (ref. 8)	3 - 12	0.79 X 0.79 5.67 D	0.61 3.87	16.41	10.00 63.48	20 680	2500	1-2 min, continuous	147	251.7
NF 4	NASA Lewis Plumbrook	5 - 7	1.07 D	0.73	16.41	12.00	8 274	2200	1/2-3 min	Unknown	Unknown
NF 5	AEDC APTU growth	6.0	1.52 D	1.04	16.41	17.07	20 680	2060	3 min	NA	0.90

ORIGINAL PAGE IS
OF POOR QUALITY

TABLE VI. - IMPACT OF NEW FACILITIES ON MILESTONE RISK LEVELS

	(4) Risk exposure factor (REF)	NF 1 (GD 20)		NF 2 (GD 7)		NF 3 (E 9)		NF 4 (Plumbrook)		NF 5 (super-APTU)	
		CRL	REF	CRL	REF	CRL	REF	CRL	REF	CRL	REF
1.0 Complete conceptual design	(14.0)										
1.1 Mission	10	NA	NA	NA	NA	NA	NA	NA	NA	NA	NA
1.2 Parametric conceptual analysis	4	↓	↓	↓	↓	↓	↓	↓	↓	↓	↓
1.3 Conceptual drawing	0	↓	↓	↓	↓	↓	↓	↓	↓	↓	↓
2.0 Prepare airframe design base	(23.1)										
2.1 Airframe aero analysis	2.1	NA	NA	NA	NA	NA	NA	NA	NA	NA	NA
2.2 Inlet and module aero analysis	1.4	↓	↓	↓	↓	↓	↓	↓	↓	↓	↓
2.3 Airframe and inlet scaling and viscous criteria	7	0.67	2.1	0.62	5.6	0.61	6.3	↓	↓	↓	↓
2.4 Airframe and inlet performance validation	5.6	.68	1.4	.64	4.2	.63	4.9	↓	↓	↓	↓
2.5 Airframe and inlet parametric characteristics	7	.66	2.8	.62	5.6	.61	6.3	↓	↓	↓	↓
3.0 Prepare Scramjet design base	(51.1)										
3.1 Scramjet aero analysis	4.9	NA	NA	NA	NA	NA	NA	NA	NA	NA	NA
3.2 Nozzle aero analysis	7.0	↓	↓	↓	↓	↓	↓	↓	↓	↓	↓
3.3 Scramjet and nozzle scaling criteria	10.5	↓	↓	↓	↓	.67	2.1	0.63	4.9	0.64	4.2
3.4 Scramjet performance validation	9.8	↓	↓	↓	↓	.68	1.4	.64	4.2	.64	4.2
3.5 Nozzle performance validation	8.4	↓	↓	↓	↓	.66	2.8	.62	5.6	.63	4.9
3.6 Scramjet and nozzle parametric characteristics	10.5	↓	↓	↓	↓	.65	3.5	.58	8.4	.58	8.4
4.0 Complete design integration	(31.5)										
4.1 Force accounting method	0	NA	NA	NA	NA	NA	NA	NA	NA	NA	NA
4.2 Inlet and modules integration	13.5	.75	4.5	.67	11.7	.68	10.8	.66	12.6	.66	12.6
4.3 Nozzle integration	18	.65	13.5	.62	16.2	.63	15.3	.61	13.3	.61	13.3
4.4 Integration design optimization	0	NA	NA	NA	NA	NA	NA	NA	NA	NA	NA
5.0 Validate integrated design criteria	(35)										
5.1 Predict integrated vehicle performance	0	NA	NA	NA	NA	NA	NA	NA	NA	NA	NA
5.2 Validate integrated vehicle performance	35	.55	30.0	.52	33.0	.54	31.0	.51	34.0	.51	34
5.3 Establish design and performance correlation	0	NA	NA	NA	NA	NA	NA	NA	NA	NA	NA
(Risk exposure factor summation) →	(154.7)		(122.9)		(144.9)		(113.8)		(132.0)		(130.6)

NA: Facility not applicable - risk unchanged from current facility ratings

NF2 is the proposed HYFAC GD7 gas piston impulse tunnel which is designed to operate with clean air at high Reynolds numbers over the Mach number range of 8 to 13. Two test legs are employed. One leg operates at Mach 8 through 10, the other at Mach 10 through 13. Both legs have 3.05-m diameter test sections. A number of options are open for the type of heater to be used, and the test gas can be either air or nitrogen.

The gas piston impulse driver uses a technique developed at the Naval Ordnance Laboratory (NOL), whereby cold gas at the reservoir pressure is admitted to the upstream end of a heated reservoir. The cold gas acts as a gas piston to maintain reservoir pressure and expel most of the heated gas. These features eliminate the nonconstant reservoir conditions associated with most fixed volume, reservoir impulse facilities. Primary advantage over other impulse techniques is the much longer run times available.

NF2 (GD7) SPECIFICATIONS

Legs 1 & 2

Test section	3.05 m diameter
Run time	1 to 4 sec
Mach number	8 to 13
Stagnation pressure kN/m^2	2,068 to 124,110
Stagnation temperature ° K	672 to 1,400
Estimated cost (1970)	\$26.6 million
(1980)	\$45.5 million

Milestones 2.3 (airframe and inlet scaling and viscous criteria), 2.4 (airframe and inlet performance validation) and 2.5 (airframe and inlet parametric characteristics), are basically dependent on Mach number, Reynolds number simulation. Current facilities cannot adequately cover the Reynolds number range of the hypersonic vehicle, as shown in figure 12. This situation is generally true throughout the lower supersonic and transonic range also, and the need for higher Reynolds number test facilities exists over a wide range. At the lower speeds, this problem has been reduced in severity by a gradual

ORIGINAL PAGE IS
OF POOR QUALITY

accumulation of wind tunnel and flight test data, and analysis. Fairly reliable procedures have been developed for extrapolation of viscous characteristics. However, a like amount of data and experience has not yet been accumulated at hypersonic speeds. This situation could be alleviated by construction and use of either or both NF1 and NF2.

The Reynolds number capability of proposed facilities NF1 and NF2, based on the maximum-sized model criteria ($L = \sqrt{c}/1.3$), would substantially duplicate the flight corridor Reynolds number of a 30.48-m vehicle from Mach 2 to 13, as shown in figure 14. In the Mach range of 3 to 6, the Reynolds number could be increased by factors of from 1.4:1 to 4.2:1 over the current continuous flow tunnel capability. The proposed NF1 facility could not, however, offer higher Reynolds numbers than the Holloman Rocket Sled (F20). The sled technique is currently available but does not offer many of the testing advantages and flexibility of the more conventional NF1. In the Mach 8 to 10 range, the proposed NF2 offers no improvement in Reynolds number over the AEDC-F Hot-Shot Tunnel (F13), but would be superior in the Mach 10 to 13 range. NF2 would also be superior to AEDC-F in other parameters such as longer run times, less flow contamination, and more stable flow properties.

Milestone 4.2 (inlet and modules integration) requires testing with air-frame inlet and modules simulated so as to determine the details of interactions between these components. The combustion process need not be simulated. Milestone requirements are similar to milestone 2.5, except greater emphasis is placed on measurement of viscous interaction characteristics which are heavily dependent on Reynolds number simulation. New facilities NF1 and NF2 could provide this satisfactory Reynolds number range, and the large test section size and long run times would permit greater precision of geometric simulation and instrumentation.

Milestone 4.3 (nozzle integration) requires that tests be conducted to determine the interactions between the nozzle flow, vehicle, and external flow. A functioning scramjet multimodule engine would be required to fully simulate all the details of the subject interactions. This would also require duplication of flight properties of Mach number, pressure, and temperature for the engine to operate. No future facility concepts have been proposed that would be large enough to provide this simulation assuming a minimum scramjet engine size of $h = 20$ cm.

A less satisfactory alternate test method is to use a simulant gas for the scramjet effluent. This requires use of a faired over inlet and a complicated series of tests with reference models. With this method, facilities NF1 and NF2 would provide an improved test capability through higher Reynolds number and larger model sizes.

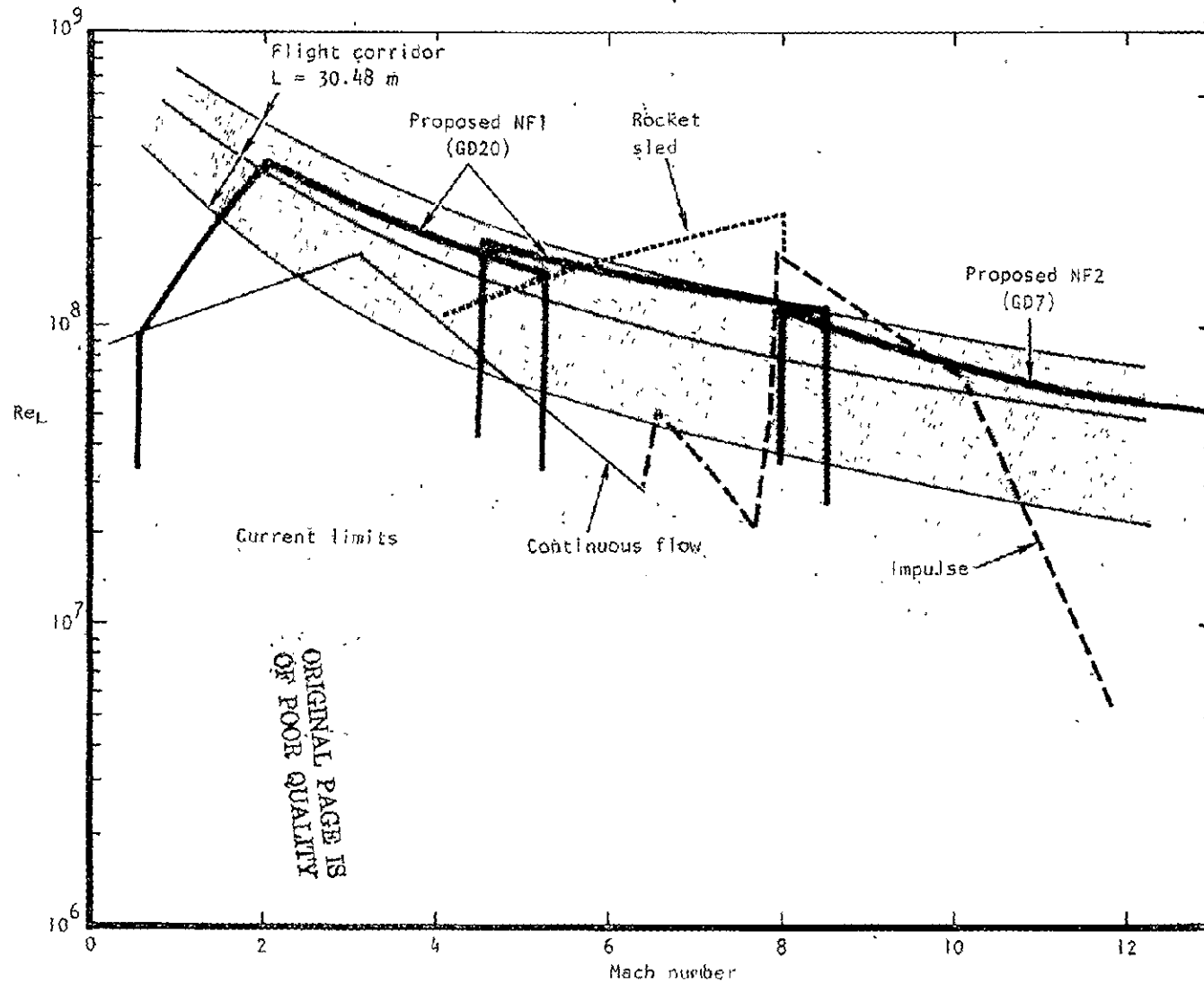

Figure 14. - New ground facility potential for Reynolds number simulation.

Three proposed facilities were selected to permit larger scale model testing with flight duplicated conditions in support of hot module and nozzle testing. NF3 is the HYFAC E9 Dual Mode Scramjet Facility. This is a combination continuous vitiated air, intermittent clean-air engine facility. It can provide flight duplicated conditions over a Mach 3 to 10 range and 250-kg per second mass flow. A number of combinations of heater systems have been proposed for NF3 to permit operation with clean, clean synthetic, and vitiated synthetic air, with run times varying from 1 minute to continuous. The higher Mach number flight duplicated conditions would be made possible by a hybrid heater system that would combine a zirconia storage air heater and a vitiating carbon monoxide reactor system. The CO system is fed from the reaction of pelletized carbon black and oxygen. The hot CO is then burned with heated air and oxygen in a continuous process. O₂ is added to the mixture to restore the free-air concentration of oxygen. This method of vitiation eliminates the condensation problems associated with hydrocarbon fuel vitiation that forms water. However, the CO₂ formed may also have an undesirable influence on the scramjet combustion process. Details of the operation and performance of this vitiation system have not yet been obtained.

NF3 (E9) SPECIFICATIONS

Test section (var 2-D or axisym)	0.613 m ² (M = 3) to 5.67 m diameter (M = 12)
Run time	1 min/continuous, depends on heater system
Mach number	3 to 12 (flight duplication to M10)
Stagnation pressure	20,685 kN/m ²
Stagnation temperature	3,920° K
Estimated cost (1970)	\$147 million
(1980)	\$251.7 million

**ORIGINAL PAGE IS
OF POOR QUALITY**

NF4 is the NASA Lewis Plumbrook Hypersonic Engine Test Facility. This facility is not operational, having been closed down and mothballed. It is a high-temperature, blowdown facility using 1.07-m exit diameter free-jet nozzles to produce nominal Mach numbers of 5, 6, and 7 in the test section. This facility was used for free-jet tests of the NASA 45.7-cm diameter aerothermodynamic integration model (AIM) (ref. 43). This engine was a water-cooled, hydrogen-fueled, full-scale configuration of the hypersonic research engine (HRE) concept.

The facility used an induction-heated, drilled core, graphite storage bed to raise the temperature of nitrogen to a nominal 3000° K at a maximum design pressure of 8274 kN/m². The nitrogen was mixed with ambient-temperature oxygen to produce synthetic air. Diluent nitrogen was added with the oxygen in the mixture at tunnel Mach numbers below 7 to control free-stream total temperature and to supply the correct weight flow.

With the phasing out of the X-15 program, the HRE development was stopped, and the Plumbrook facility was closed down.

NF4 (NASA Lewis Plumbrook)

Test section	1.07 m diameter
Run time	2 to 3 min
Mach number	5, 6, and 7
Stagnation pressure	8274 kN/m ²
Stagnation temperature	2072 °K (design) 1736 °K (measured)
Estimated cost to reactivate	Unknown

The deficiency in stagnation temperature noted in the preceding NF4 table was due in part to deterioration of the heater and a lack of time to implement necessary repairs.

NF5 is a growth modification of the AEDC APTU facility. The APTU is a high-pressure, stored air system with blowdown through a bebble-bed heater to atmosphere or to jet-pump assisted, subatmospheric exhaust. Clean-air temperature limit is 1670° K and flight duplication can be simulated to altitudes of

15.2 km to 26.8 km and Mach 6.0. The proposed modification would allow increasing the maximum facility nozzle from 1.0-m to 1.52-m exit diameter. Two methods for accomplishing this have been proposed:

(1) Replace pebbles in current heater with bricks to obtain three and one-half to four times the present mass flow. Estimated cost is \$850,000.

(2) Use instream vitiating heating with O₂ replenishment. Estimated cost is \$1,050,000.

NF5 (AEDC APTU GROWTH) SPECIFICATIONS

Test section	1.52 m diameter maximum
Run time	3 min
Mach number	2-6 clean air 6-8 vitiated
Stagnation pressure	24,132 kN/m ²
Stagnation temperature	1,680° K 2,800° K (vitiating)
Estimated cost to modify (1978)	\$850,000 (plan (1))

Milestones 3.3 (scramjet and nozzle scaling criteria), 3.4 (scramjet performance validation), 3.5 (nozzle performance validation), and 3.6 (scramjet nozzle parametric characteristics) are primarily concerned with testing the scramjet module and nozzle. Flight corridor Mach number, pressure, and temperature simulation are needed to test these components and determine their baseline characteristics. Current ground facilities capable of this simulation are basically limited in size, as shown by the comparisons in figure 13. The proposed new facilities NF3, NF4, and NF5 could make testing possible of larger scale modules at flight duplicated conditions, as shown in figure 15. The NF3 facility would permit testing of larger operational scramjet modules, which could be full scale (76 cm in height or larger) over the Mach 4 to 6 range with clean air, and from Mach 6 to 10 with CO vitiation. Proposed facility NF4 would not permit larger module testing than is currently possible in the AEDC APTU F19 facility, but would extend the clean-air testing range from

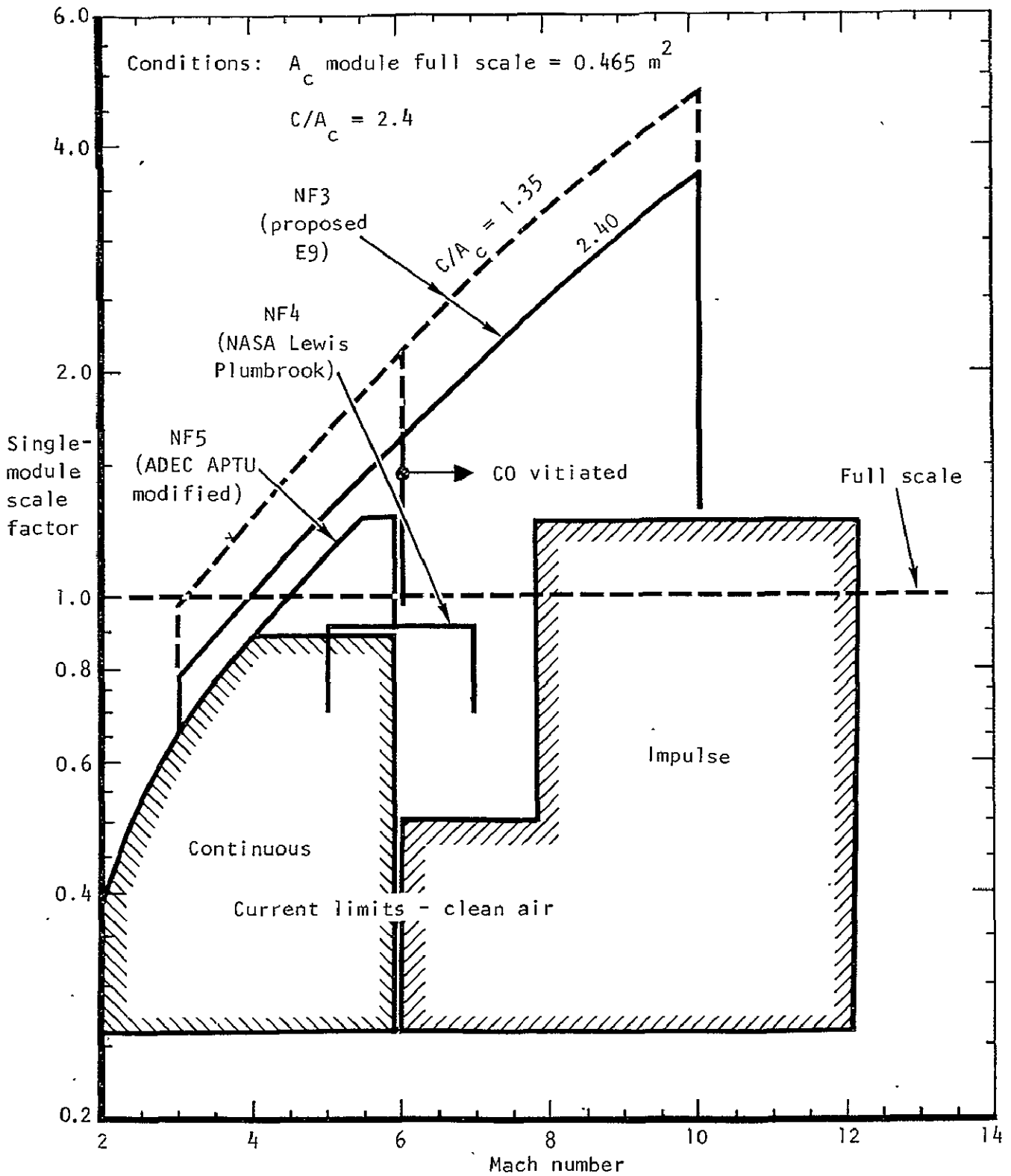

Figure 15. - Single-module scale limits with new facility full-flight simulation.

Mach 6 to Mach 7. Modifications to F19 converting it to NF5 would permit testing of 1.28 scale modules ($h = 97$ cm) at Mach 6. Both NF3 and NF5 would also be large enough to test either three 1/2 scale modules, four 2/5 scale modules, or five 1/3 scale modules ($h = 76$ cm full size). This capacity would facilitate the testing of hot operational multiple modules with a substantial portion of the vehicle nozzle attached. Jet stretchers (specially contoured test section walls) would be needed to maintain reasonable flow simulation around the modules and nozzle plume.

Milestone 5.2 (validate integrated vehicle performance) requires proof testing of the complete vehicle including functioning scramjet engines. No future ground facility concepts have been proposed that would be large enough to meet this milestone. Alternate solutions to meeting this milestone using ground facilities would require one of the following developments:

(1) Development of a subscale miniature operational scramjet engine ($h = 3.0$ to 7.5 cm).

(2) Development of the simulant gas technique with proper accounting for lack of simultaneous simulation of module inlet and exit flow.

Applicability and usefulness of proposed new ground facilities would then depend on the successful development of one of these techniques. Pending this possibility, this study concludes that new ground facility development can have only a minimum impact on meeting milestone 5.2.

The estimated impact of the proposed new facilities on the milestone risk levels is recorded in table VI. The REF (risk exposure factor), assuming only the use of current ground facilities, summed overall the milestones is equal to $REF = 154.7$. It should be noted that a portion of this REF is associated with milestones that are not related to test facilities. That portion is equal to $REF = 17.5$.

Examining the effect of each of the five proposed new facilities individually, it is seen that NF3 (HYFAC E9) has the greatest impact, reducing REF from 154.7 to 113.8. The ability to test large-scale scramjet modules and nozzles in a flight-duplicated atmosphere is the dominating criteria. The second greatest impact is made by NF1 (HYFAC GD20). This facility would make important contributions due to the flight Reynolds number duplication of aerodynamic models, and also would provide improved support of testing with the simulant gas technique. It would reduce the REF from 154.7 to 122.9.

Facilities NF4 and NF5 are fairly evenly matched in risk exposure reduction since they would have similar operating characteristics. Facility NF5 would reduce the REF from 154.7 to 130.6, primarily through ability to

test larger scramjet modules and nozzles. Facility NF2 (HYFAC GD7) appears to be of least interest as it is tailored to the Mach number range of 8 to 13. The flight corridor from Mach 1 to 8 is of more immediate concern, and facility NF1 could cover that range with high Reynolds number simulation needed for aerodynamic testing. If NF2 were to be designed to cover the lower hypersonic Mach range as well, its usefulness would be greater and would possibly be more cost effective than NF1.

If the individual facilities with the lowest REF rating were selected for supporting each milestone, two would be chosen, NF1 and NF3. Summed for all milestones, the resulting REF would equal 93.5. The potential risk exposure factor reduction with this facility combination is portrayed by the bar chart comparison shown in table VII.

Estimated costs of the proposed facilities are compared together with the risk exposure factors in table VIII. The NF5 facility appears to be the most cost-effective alternative. However, such a decision must take into account the relative utility of all these facilities in supplying the needs of other technology areas.

Role of the Hypersonic Research Airplane

The foregoing study shows that the development of new ground-based test facilities, although providing valuable help in development of integrated vehicles, cannot do more than make modest reductions in the risk exposure of a new vehicle prototype development. An alternate solution to this problem is to make use of a flight research test vehicle. This approach follows a strong precedent in the development of many advanced vehicle concepts. For example, the rocket-powered USAF/Bell X-1 (figure 16) made the world's first supersonic flight in 1947. The USAF/Lockheed X-7 (figure 17) was an unmanned ramjet-powered flight test vehicle that was air-launched from a B-29, boosted by a solid-propellant rocket engine to supersonic speeds where the 20-inch-diameter ramjet engine took over and accelerated the vehicle to Mach 3. A number of flights were made in 1953 with Curtiss Wright and Marquardt ramjet engines being alternately evaluated. This work led directly to the development of Bomarc, the USAF/Boeing/Marquardt ground-launched cruise missile. In 1959, the USAF/North American Aviation X-15 rocket-powered flight test vehicle (figure 18) was first flown. This manned vehicle was highly successful in generating a broad range of hypersonic design and performance data. A total of 199 flights were made in a 9-year period, ranging to Mach 6.7 and an altitude of 354,000 feet.

These early research airplane flights helped lay bare many of the "mysterious" problems of transonic, supersonic, and hypersonic flight. Although

TABLE VII. MILESTONE RISK FACTOR COMPARISON

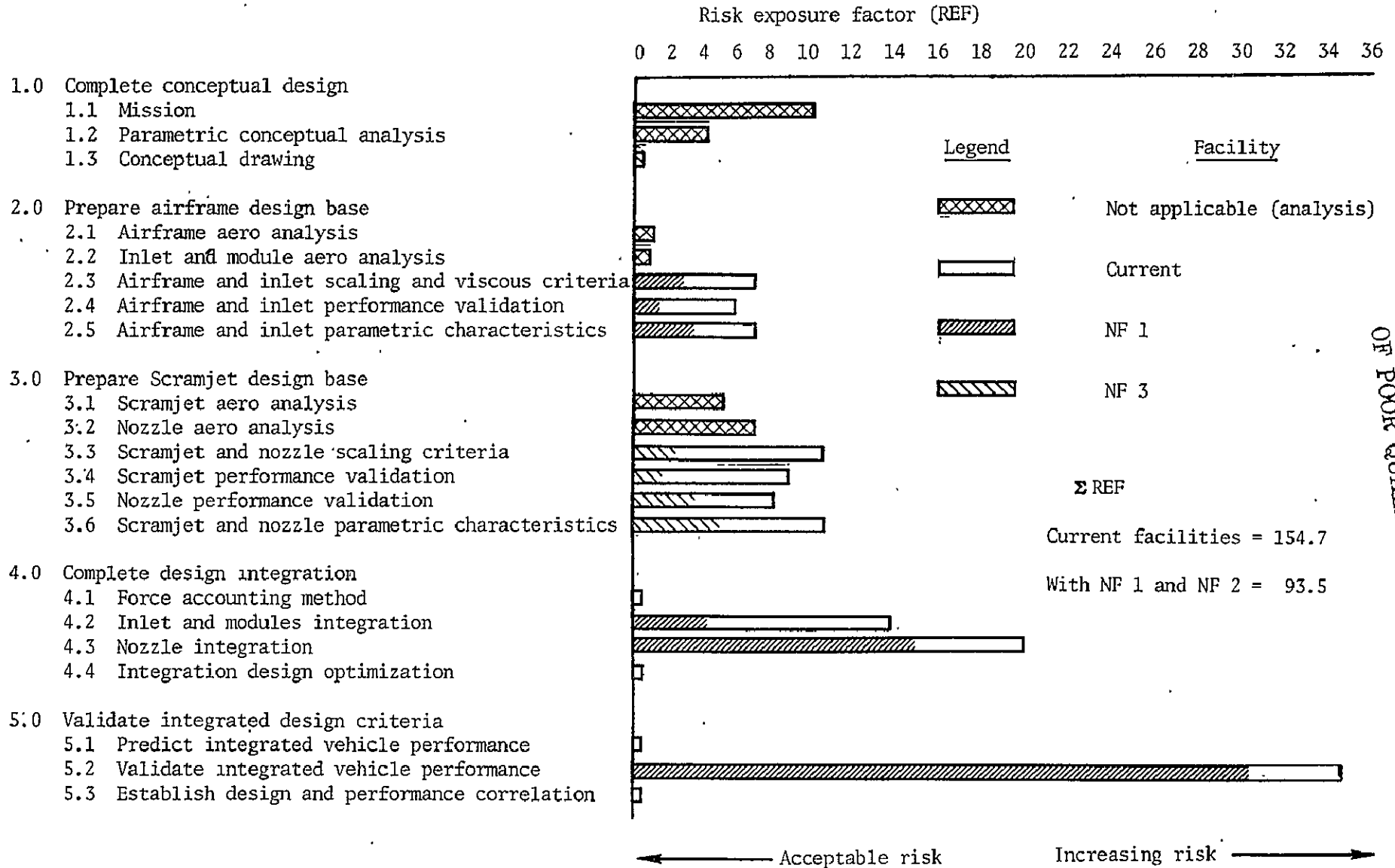

ORIGINAL PAGE IS OF POOR QUALITY

TABLE VIII. - NEW GROUND FACILITY ESTIMATED COSTS

Facility	Risk exposure factor	Cost \$M, 1970	Cost \$M, 1980
Current	154.7	-	-
NF 1	122.9	131.7	225.5
NF 2	144.9	26.6	45.5
NF 3	113.8	147	251.7
NF 4	132.0	Unknown	Unknown
NF 5	130.6	-	0.9
NF1 + NF3	93.5	278.7	477.2
NF1 + NF5	105.4	132.6	226.4

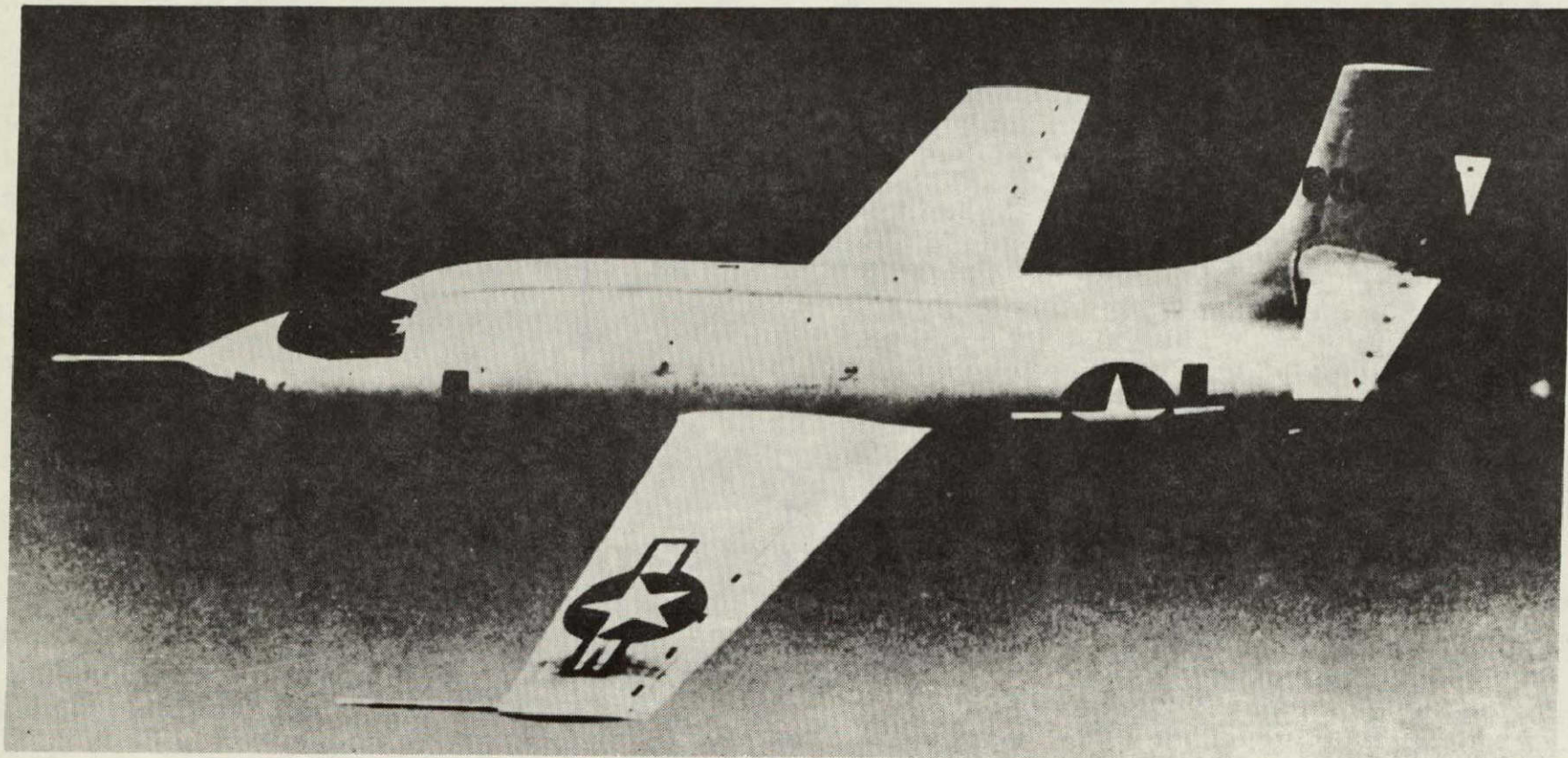

Figure 16. - X-1 rocket powered supersonic flight test vehicle - 1947.

ORIGINAL PAGE IS
OF POOR QUALITY

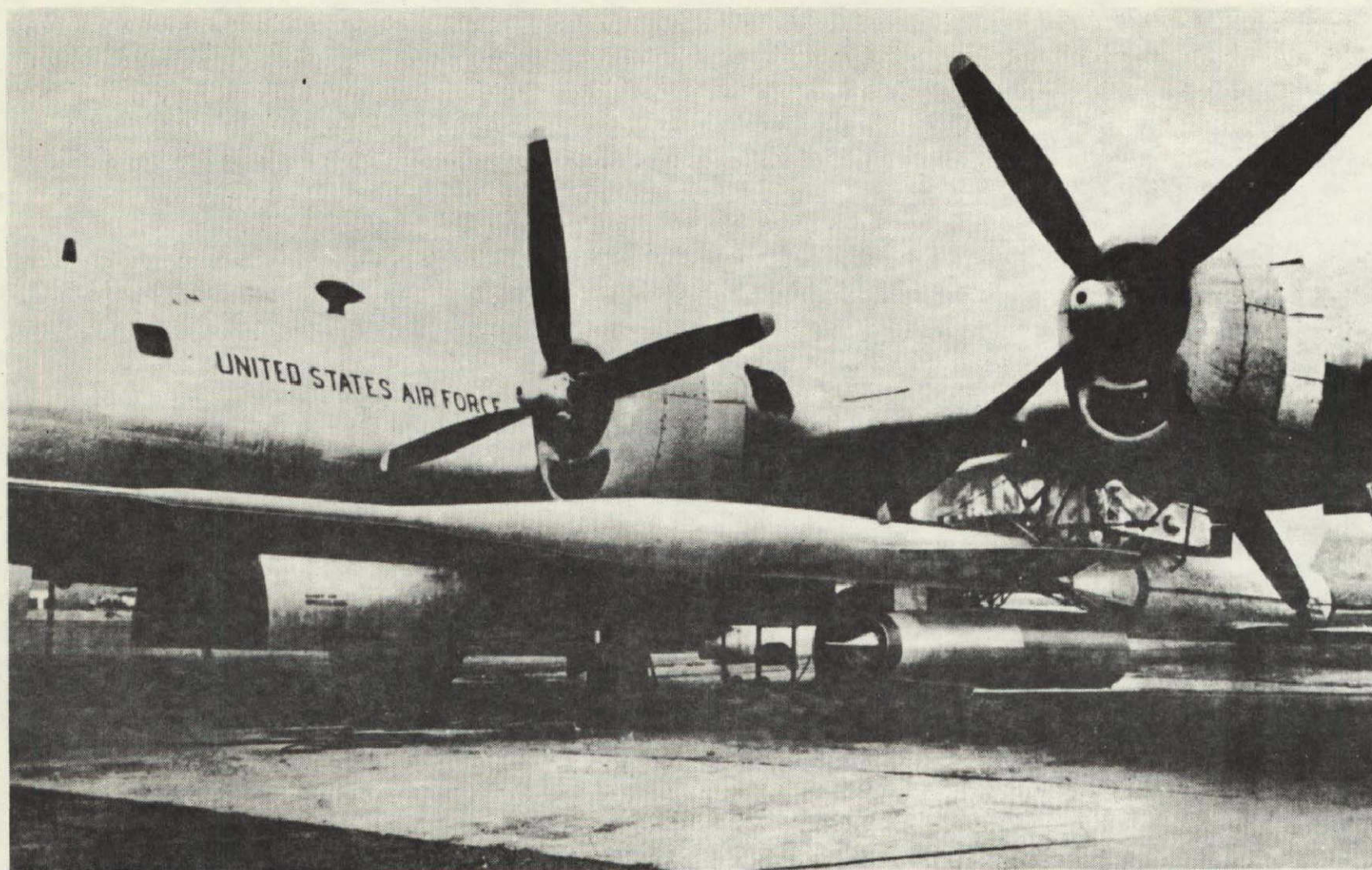

Figure 17.- X-7 Supersonic Ramjet flight test vehicle - 1953.

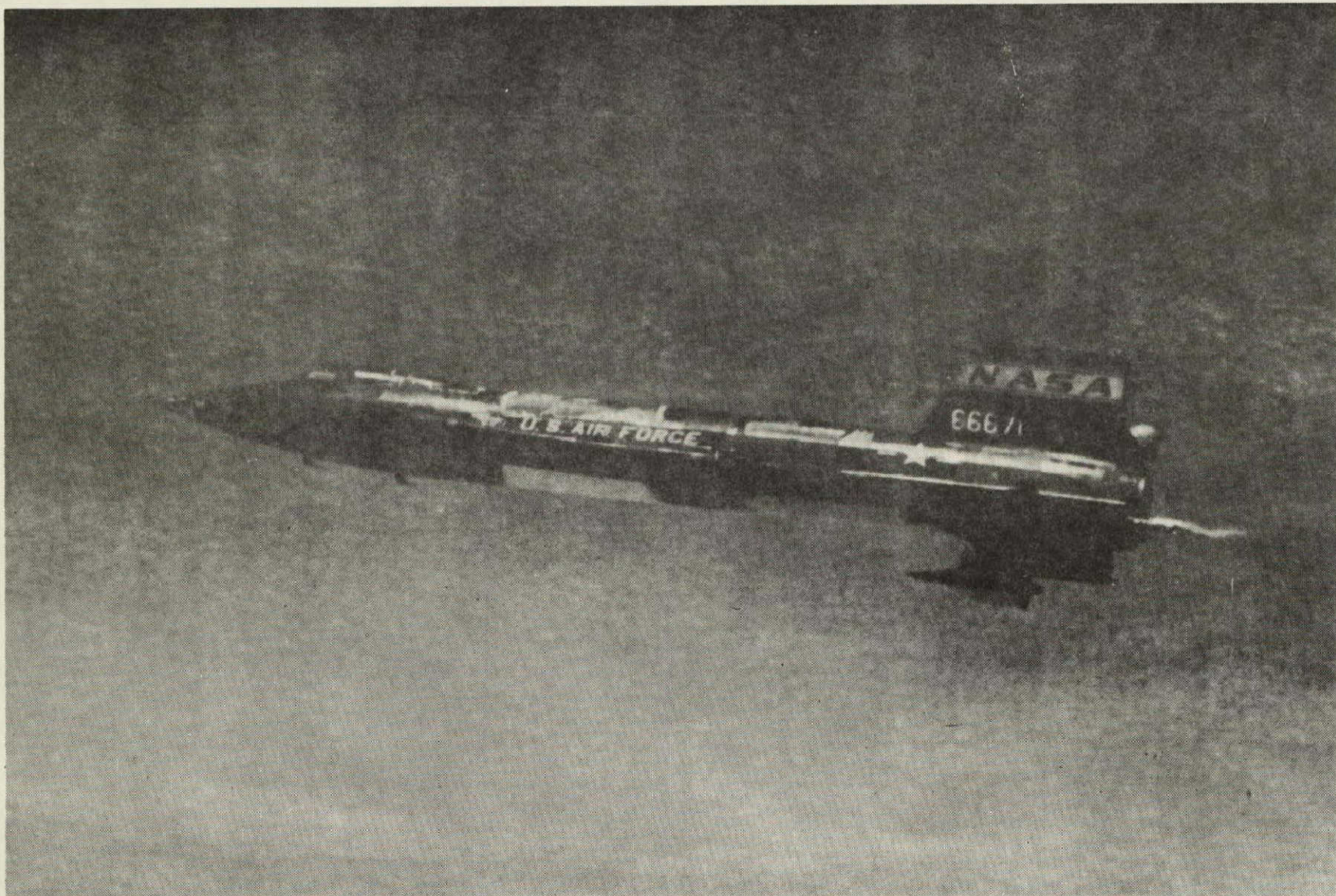

Figure 18.- X-15 rocket-powered hypersonic flight test vehicle
with simulated scramjet engine experiment - 1968.

ORIGINAL PAGE IS
OF POOR QUALITY

impressive ground test facilities existed and new ones were being developed, there were always doubts about the accuracy and the applicability of the ground-based simulation. The flight tests filled in many of these technology voids and provided their most important contribution, as defined succinctly by Hugh Dryden, "...they separated the real from the imagined problems and made known the unappreciated problems."

The current effort toward a hypersonic flight research vehicle that would be applicable for study of airframe/propulsion integration technology centers around the X-24 program and its evolution into the NHFRF concept, which has been used in the present study as a focus for definition of a prototype aircraft concept. It is not intended, however, that the NHFRF configuration be considered the only applicable concept. The immediate question is: How can a flight test vehicle reduce the risks in meeting the airframe/propulsion integration technology milestone?

Milestone 2.3.- Airframe and inlet scaling and viscous criteria.- A hypersonic research airplane (HRA) would permit testing at true flight conditions with full-scale or near full-scale configurations. Viscous effects and interactions would be generated under a dynamic real-time flight history that cannot be simulated in steady-state or impulse ground facilities. Although current and proposed ground facilities could simulate near-full-scale Reynolds numbers, these data must be obtained from several different facilities, each of which can only cover a portion of the flight corridor, using inconsistent measuring techniques.

Milestone 2.4 - Airframe and inlet performance validation.- Risk exposure factor of this milestone is associated with the lack of a proven viscous scaling methodology. This could be established with an HRA, as discussed for milestone 2.3. Also, the HRA would provide a more realistic duplication of the vehicle configuration than would be feasible on a model. Transient characteristics of the airframe and inlet could be produced which would be unfeasible in a ground test.

Milestone 2.5 - Airframe and inlet parametric characteristics.- Again, the HRA could assist in the attainment of this milestone by supporting the establishment of a viscous scaling methodology. An HRA could explore a greater range of flight conditions, control inputs, and vehicle attitudes.

Milestone 3.3 - Scramjet and nozzle scaling criteria.- The HRA would permit tests of full-scale engine modules singly and in multiples with nozzle over a true flight corridor. A baseline could be established for scaling criteria of subscale ground testing of engine components.

Milestone 3.4 - Scramjet performance validation.- An HRA proof test of the scramjet engine would provide a more complete and exact representation than could be generated in any current or proposed ground facility. It would eliminate such questions as the effect of unrealistic wall heating, imperfect test air synthesis, and impurities associated with ground facilities. When ground test facilities are used to generate the higher velocity range of flight corridor characteristics (above M6), the high temperature required causes some dissociation of the test air in the facility nozzle reservoir. This can result in a reduction of the molecular oxygen content of the test air in the combustor because of the formation of stable oxides (ref. 44).

Milestone 3.5 - Nozzle performance validation.- The ground-based techniques for proof testing the scramjet nozzle suffer all the risk-generating problems associated with the scramjet module testing plus a few additional ones. An HRA would eliminate the difficulty in generating correct module exit flow characteristics, including the gas chemical kinetic characteristics as well as intermodule wakes and viscous effects. A flight test would also avoid the critical and restrictive size limitations noted for nozzle testing.

Milestone 3.6 - Scramjet and nozzle parametric characteristics.- An HRA would permit tests of scramjet and modules over a wider range of flight conditions and vehicle attitudes than could be simulated in current or proposed ground facilities. This could be done without compromises introduced by scale effects, impure air, mismatches between module and nozzle separate development, and inaccuracies of simulant gas techniques.

Milestone 4.2 - Inlet and modules integration.- The HRA could assist in the attainment of this milestone by supporting the establishment of a viscous scaling methodology, as in milestone 2.5.

Milestone 4.3 - Nozzle integration.- The HRA would allow tests with full representation of the vehicle flow field around the inlet, modules and nozzle. This is not possible in current or proposed ground facilities without accepting increased risk with simulation compromises.

Milestone 5.2 - Validate integrated vehicle performance.- With the scramjet engine size reduction restricted, as is believed necessary, there is no current or proposed ground facility that can support attainment of this milestone. This milestone is considered a proof test of the integrated system and is intended as a final validation for support of a design methodology that can be applied to prototype vehicles. Substitution of compromised test techniques may be the only possible ground-based solution, but this would not be without high risk. An HRA flight test would remove that risk in attaining this milestone.

ORIGINAL PAGE IS
OF POOR QUALITY

HYPERSONIC RESEARCH AIRPLANE CHARACTERISTICS

The general form that an HRA may take for efficient development of propulsion/airframe integration involves a number of choices. These should be made with consideration given to both the development risks (described for the technology milestones) and consideration of the desired prototype vehicle characteristics, so that the data obtained will have the most value. The current relatively broad range of prototype vehicle concepts, however, makes this concentration on specifics of performance and form an illusive goal. This emphasizes the flexibility and adaptability desired for the HRA.

Configuration

Prime requirement for an integrated air-breather engine (scramjet) rules out consideration of pod-mounted engines outside the vehicle flow field. The fuselage forebody provides the most useful and logical precompression surface for the scramjet inlet and therefore should be contoured to present a uniform compressed airflow to an inlet array sized and positioned to match the thrust requirements. A cruise vehicle concept will typically have a requirement for an $(L/D)_{\max} = 4.0$; thus, wing-body lift will generate the most favorable inlet flow field on the vehicle underside. A requirement for a vehicle with emphasis on acceleration with scramjet propulsion would require larger engine airflow capture and less aerodynamic lift. In this case, the engine modules could be wrapped around the bottom and top of the body, approaching a flying engine concept. Emphasis in this study, however, has been drawn to the cruise configurations.

The aft portion of the vehicle must provide room for the nozzle expansion surface, and this surface must be contoured to recover a large portion of the modules exit thrust potential. Proportioning and positioning of the forebody compression surface, modules, and nozzle expansion surface must take into account resulting moments and forces that must be kept in balance and within the regions of stability and controllability.

Size of the HRA should be chosen so that there is minimum difficulty in applying the data to a full-scale prototype design. Since prototype designs may range from lengths of 15 to over 100 m, some latitude must be accepted in satisfying scaling criteria. Current ground test facility limitations cannot do better than a one-third Reynolds number simulation of a 30 m vehicle at M_6 . A 15 m HRA, however, would raise that to one-half scale, not an appreciable improvement, but within acceptable limits for extrapolation. It would not be acceptable for scaling to a 100 m vehicle since Reynolds scaling extrapolation limit is considered to be one-fourth scale. Thus, a 100 m prototype would require data from a 25 m HRA.

A basic characteristic which has a major impact on HRA design is whether the HRA is manned or remotely controlled. Each concept has its advantages. Primary advantage of a manned HRA is the capability to deal with unscheduled, unanticipated events. The pilot can provide vehicle control and instantaneous rescheduling of flight profiles, providing useful data which might be lost in an unmanned vehicle. Even prevention of the vehicle from destruction is more likely with a piloted than a remotely controlled vehicle where malfunction of communication or guidance systems would result in loss of the vehicle. Also, with a piloted vehicle, a variable test plan is possible where later test conditions may depend on what happens initially. Many times, more data per flight can be obtained with this capability.

Disadvantages of the manned vehicle are (1) a larger vehicle is required to carry the man and associated life support and ejection systems, and (2) the man imposes limitations on the launch or boost system in terms of acceleration and the qualification or man-rating of the associated equipment and engines.

A value comparison of a manned versus unmanned HRA has been shown by the study of ref. 8 to favor the research value of the manned mode. The incremental improvement in research value is believed a greater percentage than the increase in cost.

Flight Performance

Launch mode has a strong influence on the HRA size, design, and performance. The NHFRF concept plans to use a B-52 air-launch platform. Use of an existing B-52 equipped with an inboard starboard wing mounting point (used for the X-15) keeps costs down but limits HRA wingspan to 7.9 m and a length of about 21 m. Air launch of a 30 m long HRA would require special modification and use of a C-5 or 747 aircraft.

A ground horizontal takeoff is feasible also. This option would, however, substantially reduce the fuel available for climb and acceleration to the flight test corridor. The high-gross-weight takeoff would also be more hazardous and would require additional development in ground test facilities to improve low-speed performance and handling characteristics at high gross weight.

Rocket-boosted vertical takeoff would be uneconomical for a 15 to 30 m long HRA. A smaller HRA would reduce the data scalability effectiveness.

A launch mode which has been suggested is the launching of the HRA from the Shuttle orbiter vehicle, either in orbit or during orbiter reentry (payload bay is 18 m long). A wide variety of test conditions could be established during HRA reentry. Launch from the Shuttle places additional heat protection

requirements on the HRA beyond those of a short-time Mach 6 cruise condition. The thermal protection system required to survive the reentry environment would add significant weight and cost. In addition, a protective shield would probably be required over the scramjet inlet during reentry. The cost of a Shuttle-launched test vehicle may also be prohibitive. Present estimates place the cost of each Shuttle launch at \$20 million, resulting in a cost of over \$1 million per meter of test vehicle length.

Desirable HRA performance characteristics for meeting the technology milestones can be listed as follows:

- (1) Rocket boost thrust capable of accelerating the HRA from a B-52 air launch at Mach 0.85 and 13.7 km to Mach 6 and a nominal 27.1 km altitude ($q = 47.88 \text{ kN/m}^2$). Variation in the end of boost altitude at Mach 6 from 31.7 km ($q = 23.94 \text{ kN/m}^2$) to 24 km ($q = 71.82 \text{ kN/m}^2$) would be highly desirable if permitted by vehicle aerodynamic and thermal protection characteristics.
- (2) Constant-altitude (as in item 1) cruise at Mach 6 on sustainer rocket power and/or scramjet thrust.
- (3) Steady-state cruise at Mach 6 for a minimum of 40 seconds, maximum of 5 minutes.
- (4) Sustainer rocket power shall have variable thrust from 110 to 10 percent of maximum vehicle drag at Mach 6.
- (5) Angle of attack and yaw will be varied through a range to correspond with load factors of 4 and 6 G.
- (6) Number of scramjet modules tested will be varied from none, to one, and to the design number.
- (7) Scramjet fuel/air ratios will be varied from $\phi = 0.5$ to 1.5.
- (8) Cruise flight will be followed by a power-off descent with maneuvering to a dead-stick landing.

Increasing the number of test conditions that can be established and data obtained on each flight will reduce total flight test operational costs. The longer available test time will therefore be cost effective, provided that the test vehicle costs to obtain the extended test time do not become prohibitive. The 40-second time shown is considered near minimum to establish steady-state engine conditions and obtain data at that point. Test time of 5 minutes could provide data at a range of test conditions, thus minimizing the overall flight test program.

Flight Test Program

Initial flights of the HRA would be made without the scramjet modules attached. Unpowered air-launch, glide, and landing tests will be needed to check out these basic systems and low-speed handling characteristics. Following these, rocket boost flights will be made with incremental advancements into the hypersonic flight range. These flights will measure basic aerodynamic performance of the vehicle (without scramjet), assure high-speed safety of the system, and check out instrumentation, recording, data links, and navigation techniques.

With the basic vehicle aerodynamic performance measured and calibrated in the unpowered and rocket-powered mode, tests will begin with a single scramjet module attached. One module will not provide sufficient thrust to match the vehicle drag, but this approach will simplify the preliminary tests and analysis of the installation problems. The resulting moments and trim change will only be a fraction of that for a full array of modules, reducing the risk of encountering unexpected control and stability problems. The goal will be to fly the Mach 6 cruise mission with thrust makeup supplied by the rocket sustainer engines. The one-module operation with the HRA at the Mach 6 flight point will permit substantial attainment of the following milestones:

- 2.3 - Airframe and Inlet Scaling and Viscous Criteria
- 2.4 - Airframe and Inlet Performance Validation
- 2.5 - Airframe and Inlet Parametric Characteristics
- 3.3 - Scramjet and Nozzle Scaling Criteria
- 3.4 - Scramjet Performance Validation

The single-module HRA flight tests will also contribute to partial attainment of the following milestones:

- 3.5 - Nozzle Performance Validation
- 3.6 - Scramjet and Nozzle Parametric Characteristics
- 4.2 - Inlet and Modules Integration
- 4.3 - Nozzle integration
- 5.2 - Validate Integrated Vehicle Performance

On satisfactory completion of the single-module flight tests, the full multiple array of modules would be mounted on the HRA. The NHFRF configuration of ref. 12 proposes the use of four modules. At least three would be needed to include all of the intermodule interactions of interest. An alternate plan which might prove more cost effective would be to use two identical HRA vehicles for the scramjet propulsion integration development tests. The first would be reserved for the single-module installation, with the second testing the complete engine. It is expected that an HRA program would require two or more vehicles to reduce the overall development time and effect savings through more intensive use of personnel, ground and launch equipment, and data processing.

The full scramjet engine flight tests would be conducted at the Mach 6 cruise design point. Sustainer rocket thrust would be used, if necessary, to maintain the desired flight condition during tests of the scramjet. A number of scramjet geometric and operational parameters could be evaluated in these flight tests, and many of these flights could support, on a shared basis, a number of other experiments associated with the HRA.

For the present study of propulsion/airframe integration, the following flights would be considered a minimum requirement:

<u>No. of Flights</u>	<u>Scramjets</u>	<u>Purpose</u>
3	0	Subsonic glide systems check
4	0	Rocket-powered airframe performance
2	1	Inlet and module cold-flow drag
1	1	Hot-flow operational check
3	1	Module/nozzle performance
2	1	Engine/airframe modifications
1	4	Hot-flow operational check
4	4	Module/nozzle performance
2	4	Engine/airframe modifications
1	4	Maneuver limits
3	4	Speed and altitude variation

With satisfactory completion of this flight test program, together with a ground test facility program using current facilities together with a complementary design and performance analytic effort, all applicable technology milestones could be met within acceptable risk levels.

Flight Instrumentation

Measurements would be made in the HRA flight tests to establish the flight history and environment, airframe performance, rocket thrust, scramjet performance, and interference effects. The estimated instrumentation to accomplish this (assuming six sustainer rocket engines and four scramjet modules) is comprised of two lists - the standard group and the special group shown in tables IX and X.

The standard group includes five channels needed for the air data system to track the flight history and environment. Airframe performance and interference effects are measured on 157 channels. The control surface angles are assumed to be either one or two segments of rudder and elevator deflection. The forebody and afterbody static pressures are measured nominally at either six (desired) or three (minimum) rows containing 10 pressure taps each. Static pressures are measured on the fuselage base area.

Thermocouples and strain gages in the wing and elevator, scramjet, and nozzle afterbody structures are the minimum required for trouble and safety monitoring rather than detail data gathering. The six rocket engines each require a measurement of fuel flow rate and chamber pressure. The four module scramjet engines are assumed to be broken up into two separate internal cooling systems per module. Each cooling system requires two measurements of coolant pressure and temperature. A total of 30 internal static-pressure and 12 pitot-pressure measurements are needed in the scramjet modules to monitor inlet and combustor performance.

The special group of instrumentation is needed for special portions of the test program and would be an add-on with some of the standard group removed or bypassed if channels are limited.

Judiciously placed surface pressure taps on the module and wing-body external surfaces would be needed to allow correlation with ground measurements of module/airframe interaction at lower Reynolds numbers and different wall temperature ratios. Detailed measurements of inlet flow would provide data for flow angularity and ingested boundary layer correlations. Surface pressure measurements near the edges of the exhaust plume boundaries would be used to define the nozzle/airframe interactions for correlation with ground test measurements. Pitot pressure rakes on the nozzle afterbody surface (no

TABLE IX. — HYPERSONIC RESEARCH AIRPLANE LIST OF STANDARD INSTRUMENTATION

Basic instrumentation	Number of channels	
	Desired	Required minimum
Air data system		
Pitot pressure	1	1
Static reference pressure	1	1
Total temperature	1	1
Angles of attack and sideslip α, β	2	2
Airframe		
Accelerations n_x, n_y, n_z	3	3
Control surface angles	4	2
Forebody static pressures	60	30
Nozzle afterbody static pressures	60	30
Blunt base static pressures	8	4
Thermocouples and strain gages in wing and elevator structure	16	12
Thermocouples in nozzle afterbody structure	6	2
Rocket engines		
Fuel flow rates	6	6
Chamber pressures	6	6
Scramjet engines		
Fuel coolant flow rates	8	4
Fuel coolant temperatures	16	8
Fuel coolant pressures	16	8
Internal static pressures	60	30
Pitot pressures at fuel injection struts	18	12
Thermocouples in Scramjet structure	8	2
	300	164

TABLE X. — HYPERSONIC RESEARCH AIRPLANE LIST OF SPECIAL INSTRUMENTATION

Special instrumentation	Number of channels	
	Desired	Required minimum
Nozzle afterbody boundary layer and separation Total pressure rakes	30	10
Module external instrumentation Surface pressure taps on module	30	10
Surface pressure taps on wing-body near module	30	10
Inlet instrumentation Pitot pressure rakes		
(1) Inlet flow averages	16	4
(2) Ingested boundary layer surveys	30	10
Static pressure rakes		
(1) Inlet flow averages	16	4
(2) Ingested viscous layer surveys	30	10
Ramp divider wall flow angularity probes	15	5
Nozzle airframe instrumentation Surface static-pressure taps near plume boundaries		
(1) On nozzle	10	5
(2) On module	10	5
(3) On wing and elevator	10	5
Scramjet and nozzle instrumentation Module exit cooled pitot probes	2	1
Module exit total temperature probes	2	1
Module exit gas sample probe	2	1
	233	81

ORIGINAL PAGE IS
OF POOR QUALITY

combustion) would identify separation at subsonic, transonic, and low supersonic speeds.

It is unlikely that a good direct measurement of module entering and exiting stream thrust could be obtained in flight because of the difficulty in making such surveys without disturbing the flows. Instead, module net thrust could be determined from the increment in sustainer rocket thrust required to duplicate the same flight condition as the scramjet modules. This increment must be corrected for the change in force acting on the nozzle afterbody. This force can be determined from the static-pressure measurements on the nozzle and base regions. Lift and moment components of scramjet force can be derived from vehicle attitude and control surface deflections referenced to vehicle performance with rocket power alone. Accuracy of this system is a function of a number of parameters, the most important of which is the thrust calibration of the sustainer rocket. This is currently being estimated for the proposed LR-101 engines for NHFRF as a thrust measurement accuracy of 2 percent over the throttleable range.

Flight Test Data Application

The flight test data obtained would be developed into airframe aerodynamic coefficients which would represent a flight basepoint to which lower Reynolds number ground facility test data could be correlated with, for development of further extrapolation criteria. Transition and viscous effects, in particular, would be available for adjusting the ground-based data.

Scramjet module performance in flight test would be obtained with complete, uncompromised simulation. The derived net module thrust could be correlated with net module thrust of a jetfree ground-tested subscale module. Scaling factors could be developed that would assist in improving the usefulness of even smaller subscale engines that would make better use of current ground facilities.

Nozzle forces also would be measured in true flight conditions which would serve as a base for improving the scalability of ground-based tests and applicability of simulant gas techniques.

Localized interactions between propulsion and airframe component flows would be correctly simulated in the flight tests, and their effects would be incorporated in the net vehicle performance. Diagnostic analysis of the interactions would be measured primarily with the static-pressure instrumentation. These would be compared with similar measurements in ground facility tests to assess the degree of simulation.

Emphasis in the HRA flight test program would be on the development of meaningful correlations with ground-based data and analytical techniques.

CONCLUSIONS

This study of hypersonic propulsion/airframe integration technology finds the following:

(1) Current analytical techniques are inadequate to direct the integration configuration development and performance analysis.

(2) Current ground test facilities are inadequate to simulate and measure integration effects and performance.

(3) Proposed new ground facilities are too small or too mismatched in flight simulation capability to support all critical integration development milestones.

(4) Uncertain minimum-size-scale limits of the scramjet engine handicaps use of ground facilities.

(5) A hypersonic research airplane test program could overcome the limitations of ground test facilities.

(6) An air-launched rocket boosted manned HRA with a length of 15 m or more and general characteristics of the NHRF concept would be a leading candidate for the flight test configuration.

RECOMMENDATIONS

1. Development of analytic techniques for integration analysis and configuration optimization should be continued with emphasis on 3-D and interfering flow fields.
2. Current ground facilities should be used in the support of integration studies to the limit of their capabilities and restrictions of their test techniques. This includes continued development of the simulant gas technique.
3. The AEDC APTU facility should be modified and developed to a larger clean airflow capacity in the Mach 3 to 6 range for large-scale module testing and investigation of nozzle testing methods with external flow simulated.
4. Scaling limits of scramjet modules should be investigated analytically and experimentally with a goal of development of a small-scale scramjet simulator that can simultaneously accommodate inlet and exit flows.
5. A hypersonic research airplane program should be launched to support integration technology advancement currently stalled by ground test limitations.

REFERENCES

1. Ferri, A.: Possible Directions of Future Research in Air-Breathing Engines, Combustion and Propulsion Fourth Agard Colloquium, Milan, Italy, 1960.
2. Johnston, P.J., Cabbage, J.M., and Weidner, J.P.: Studies of Engine-Airframe Integration on Hypersonic Aircraft, AIAA Paper 70-542, May 1970.
3. Weidner, J.P., Small, W. J., and Penland, J.A.: Scramjet Integration on Hypersonic Research Airplane Concepts, J. Aircraft, Vol. 14, No. 5, May 1977.
4. Cabbage, James M., and Kirkham, Frank S.: Investigation of Engine-Exhaust-Airframe Interference on a Cruise Vehicle at Mach 6, NASA TN D-6060, 1971.
5. Kirkham, Frank S., Cabbage, James M., Vahl, Walter A., and Small, William J.: Studies of Airframe-Propulsion-System Integration for Mach 6 Cruise Vehicles, NASA TN D-4128, 1967.
6. Henry, John R., and Anderson, Griffin T.: Design Considerations for the Airframe-Integrated Scramjet, NASA TMX-2895, 1973.
7. Small, William J., Weidner, John P., and Johnston, P.J.: Scramjet Nozzle Design and Analysis as Applied to a Highly Integrated Hypersonic Research Airplane, NASA TN D-8334, 1976.
8. Hypersonic Facilities Study, McDonnell Douglas Aircraft Company, NASA Contract NAS 2-5458, NASA CR-114322, Oct. 1970.
9. Hearsh, Donald P., and Preyss, Albert E.: Hypersonic Technology - Approach to an Expanded Program, Astronautics and Aeronautics, Dec. 1976.
10. Weil, Joseph: Review of the X-15 Program, NASA TN D-1278, 1962.
11. Kirkham, F.S., Jones, R.A., Buck, M.L., and Zima, W.P.: Joint USAF/NASA Hypersonic Research Aircraft Study, AIAA Paper 75-1039.
12. Gustavson, R.G.: National Hypersonic Flight Research Facility (NHFRF) Conceptual Study, Trade Study Report NA-77-1061, Dec. 1977.
13. Nichols, Mark R.: Aerodynamics of Airframe - Engine Integration of Supersonic Aircraft, NASA TN D-3390, Aug. 1966.

14. Richey, G.K., et al: Airframe - Propulsion Integration for Future Aircraft Systems, SAE Paper 680288, Apr. 1968.
15. Gentry, A.E.: Hypersonic Arbitrary Body Aerodynamic Computer Program, Douglas Aircraft DAC-61552, 1968.
16. Trexler, C.A., and Sanders, S.W.: Design and Performance at a Local Mach Number of 6 of an Inlet for an Integrated Scramjet Concept, NASA TN D-7944, Aug. 1975.
17. Anderson, G.Y.: An Examination of Injector/Combustor Design Effects on Scramjet Performance, Symposium on Air Breathing Engines, Sheffield, England, Mar. 25-29, 1974. Paper A74-39974.
18. Talcott, N.A., Jr., and Hunt, J.L.: Streamtube Analysis of a Hydrogen-Burning Scramjet Exhaust and Simulation Technique, Journal of Aircraft, Vol. 14, No. 9, pp. 918-920, Sep. 1977.
19. Bonner, E., Clever, W., and Dunn, K.: Aerodynamic Preliminary Analysis System, Rockwell/LAD, NA-77-870. (NASA CR-145284)
20. Erickson, L.L., et al: Advanced Surface Paneling Method for Subsonic and Supersonic Flow NASA CP-001 Vol. 1 pp. 25-54, Nov. 1976.
21. White, R.: Wing Vortex Lift at High Angles of Attack, Paper 9, AGARD CP-204, 1976.
22. Polhamus, E.: Prediction of Vortex Lift Characteristics by a Leading Edge Suction Analogy, Journal of Aircraft, Vol. 8, No. 4, pp. 193-199, 1971.
23. Korst, H., Chow, W., and Zumwalt, F.: Research on Transonic and Supersonic Flow of a Real Fluid at Abrupt Increase in Cross Section, Univ of Ill., Report ME TN 392-5, 1959.
24. Henderson, W.P.: Studies of Various Factors Affecting Drag due to Lift at Subsonic Speeds, NASA TN D-3584, 1966.
25. Ikawa, H.: A Reentry Hypersonic Control Effectiveness Methodology as Applied to the Space Shuttle Orbiter, AIAA Paper 77-6, Jan. 1977.
26. Ferri, A.: Review of Problems in Application of Supersonic Combustion, Journal of the Royal Aeronautical Society, Vol. 68, No. 645, Sep. 1964.

27. Edwards, C.L.W.: A Forebody Design Technique for Highly Integrated Bottom-Mounted Scramjets with Application to a Hypersonic Research Airplane, NASA TN D-8369, Dec. 1976.
28. Dash, S.; and DelGuidice, P.: Analysis and Design of Three Dimensional Supersonic Nozzles - Volume I - Nozzle-Exhaust Flow Field Analysis by a Reference Characteristics Technique. NASA CR-132350, 1972.
29. Kalben, P.: Analysis and Design of Three Dimensional Supersonic Nozzles - Volume II - Numerical Program for Analysis of Nozzle-Exhaust Flow Fields. NASA CR-132351, 1972
30. Fern, A., Dash, S., and Del Guidice, P.: Methodology for Three-dimensional Nozzle Design (ATL TR-195) NASA CR-132438, 1974.
31. Cabbage, J.M., Talcott, N.A., Jr., and Hunt, J.L.: Scramjet Exhaust Simulation Technique for Hypersonic Aircraft Nozzle Design and Aerodynamic Test, AIAA 15th Aerospace Science Meeting, Los Angeles, California, Jan. 24-26, 1977.
32. Salas, Manuel D.: The Anatomy of Floating Shock Fitting, AIAA Paper, Second Computational Fluid Dynamics Conference, Hartford, Connecticut, Jun 19-20, 1975.
33. Sadunas, J.A.: Integrated Scramjet Nozzle/Afterbody Performance Analysis, Journal of Aircraft, Vol. 13, Nov. 1976.
34. Ratliff, A.W., Smith, S.D., and Penny, M.M.: Rocket Exhaust Plume Computer Program Improvement, LMSC/HREC D162220-I, Lockheed Huntsville Research and Engineering Center, Huntsville, Alabama, Jan. 1972.
35. Oman, R.A., Foreman, K.M., Leng, J., and Hopkins, M.B.: Simulation of Hypersonic Scramjet Exhaust, NASA CR-2494, Mar. 1975.
36. Hartill, W.R.: Method for Obtaining Aerodynamic Data on Hypersonic Configurations with Scramjet Exhaust Flow Simulation, NASA CR-2831, Jun. 1977.
37. Boatright, W.B., et al: Langley Facility for Tests at Mach 7 of Subscale, Hydrogen-Burning Airframe - Integratable, Scramjet Models, presented at AIAA 14th Aerospace Sciences Meeting, Washington, D.C., Jan. 1976.
38. Peake, D.J.: Controlled and Uncontrolled Separation in Three Dimensions, Proceedings of Lockheed-Georgia Viscous Flow Symposium, Jun 1976.

39. Reubush, D.E.: Reynolds' Number Effects on Boattail Drag of Wing-Bodies, Journal of Aircraft, Vol. 14, No. 5, pp. 455-459, May 1977.
40. Korkegi, R.: Survey of Viscous Interactions Associated with High Mach Number Flight, AIAA Journal, Vol. 14, No. 5, pp. 597-600, May 1976.
41. Neumann, R.D., and Hayes, J.R.: Prediction Techniques for the Characteristics of the 3-D Shock Wave Turbulent Boundary Layer Interactions, AIAA Paper 77-46, Jan. 1977.
42. Scaggs, N.E., and Dunn, R.G.: Development of a Facility for Supersonic Combustion Simulation, presented at the AIAA Geodynamics Testing Conference, Los Angeles, California, 21-23 Sep. 1966.
43. Andrews, E.M., and Mackley, E.A.: Hypersonic Research Engine/Aerothermodynamics Integration Model-Experimental Results, NASA TMX-72821, Apr. 1976.
44. Ross, R.O.: Scramjet Ground Test Simulation Requirements and Facilities Capability, Marquardt Report 6052, May 1964.

End Date Filmed

APR 28, 1978