

General Disclaimer

One or more of the Following Statements may affect this Document

- This document has been reproduced from the best copy furnished by the organizational source. It is being released in the interest of making available as much information as possible.
- This document may contain data, which exceeds the sheet parameters. It was furnished in this condition by the organizational source and is the best copy available.
- This document may contain tone-on-tone or color graphs, charts and/or pictures, which have been reproduced in black and white.
- This document is paginated as submitted by the original source.
- Portions of this document are not fully legible due to the historical nature of some of the material. However, it is the best reproduction available from the original submission.

NASA Technical Memorandum 78761

(NASA-TM-78761) MODIFIED COMPOSITE
MATERIALS WORKSHOP (NASA) 355 p HC A16/MF
A01 CSCI 11D

N78-30178

Unclas
G3/24 28586

MODIFIED COMPOSITE MATERIALS WORKSHOP

Dennis L. Dicus, Compiler

JULY 1978

NASA

National Aeronautics and
Space Administration

Langley Research Center
Hampton, Virginia 23665

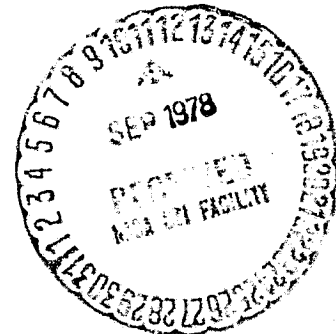

MODIFIED COMPOSITE MATERIALS

WORKSHOP

(Held at Langley Research Center, Hampton, Virginia,
March 23-24, 1978)

DENNIS L. DICUS, Compiler

JULY 1978

PREFACE

A hazard which results from accidental release of graphite fibers from composite materials has been identified. The risk resulting from this hazard is being evaluated. In the meantime, NASA has initiated a program to explore alternate materials which eliminate the hazard or reduce the risk. On March 23 and 24, 1978, NASA Langley Research Center sponsored a Modified Composite Materials Workshop. This workshop was intended to display the NASA program on alternate materials and to solicit new ideas for other alternate materials.

Working groups were organized to consider six topics: epoxy modifications, epoxy replacement, fiber modifications, fiber coatings and new fibers, hybrids, and fiber release testing. Because of the time required to develop a new material and acquire a design data base, most of the workers concluded that a modified composite material would require about four to five years of development and testing before it could be applied to aircraft structures. However, the Hybrid Working Group considered that some hybrid composites which reduce the risk of accidental fiber release might be put into service over the near term. The Fiber Release Testing Working Group recommended a coordinated effort to define a suitable laboratory test. That group did not have sufficient time to give careful consideration to the problems of large scale outdoor testing to prove the performance at full scale of proposed alternate materials. Most groups expressed a desire for further interaction with NASA in their technology areas in the future to monitor progress.

Hampton, Virginia
July 11, 1978

General Chairman

William A. Brooks, Jr. - NASA Langley Research Center

Administrative Chairman

Dennis L. Dicus - NASA Langley Research Center

Program Co-Chairmen

Robert T. Swann - NASA Langley Research Center

Norman J. Johnston - NASA Langley Research Center

Working Group Chairmen

E. Bruce Belason - AVCO Specialty Materials Division

Russell J. Diefendorf - Rensselaer Polytechnic Institute

James Economy - IBM Research Laboratory

Billy F. Landrum - Ciba-Geigy Corporation

James Noland - American Cyanamid Company

Karl M. Prewo - United Technologies Research Center

CONTENTS

	<u>Page</u>
PREFACE	i
INTRODUCTION	1
AGENDA	3
PRESENTATIONS	
Workshop Expectations	5
Potential Graphite Fiber Problems	8
Review of NASA Langley Materials Modification Program	
Overview	25
Improved High Modulus Fibers	29
Graphite Fibers with High Electrical Resistivity .	47
Silicon Carbide, Boron, and Glass Coated	
Graphite Fibers	54
Boron Carbide and Silicon Carbide Coated	
Graphite Fibers	69
Boron Nitride, Silicon Carbide, and Silicone	
Coated Graphite Fibers	77
Review of NASA Ames Materials Modification Program	
An Approach to the Development of Fire	
Resistant Composites	80
Preliminary Test Results of the Fiber	
Release Characteristics of Baseline	
Graphite Epoxy Composites Compared	
With New Char Forming Analogs	103
Review of NASA Lewis Materials Modification Program . .	117
Fiber Release Testing Facilities and Results	140
WORKING GROUPS	
Graphite Fiber Modifications	150
Issues	151
NASA Reporters' Summary	152
Chairman's Report	157
Hydrogenation of Carbon Fibers	168
Graphite Fiber Coating and Alternative Fibers	170
Issues	171
NASA Reporters' Summary	172
Chairman's Report	177
Organic Fibers and Hybrid Composites	187
Boron Nitride Fibers	203
Electrodeic Coatings	206
Some Ideas and Preliminary Results to	
Alleviate Electrical Problems of	
Carbon Fiber Composites	215
Epoxy Resin Modifications	225
Issues	226
NASA Reporters' Summary	227
Chairman's Report	229

CONTENTS (Continued)

	Page
Epoxy Resin Replacements	235
Issues.	236
NASA Reporters' Summary	237
Chairman's Report	240
NRL Work on Polyphthalcyanine	248
NCNS Resins	257
Low Shrinkage Resins	266
Materials Development Requirements -	
Airborne Carbon/Graphite Fibers	279
Hybrid Composites	288
Issues.	289
NASA Reporters' Summary	290
Chairman's Report	293
Fiber Release Simulation Testing	302
Issues.	303
NASA Reporters' Summary	304
Chairman's Report	306
Fire and Impact Testing	311
Fiber Release Simulation Testing	323
Fire Testing of Graphite-Epoxy	
Composites in AVCO's Model 25	
Fire Test Facility	332
APPENDIX A Conversion of Miscellaneous Units to SI Units	344
APPENDIX B List of Attendees	345

INTRODUCTION

Graphite fibers in an epoxy matrix provide a composite material having high strength and stiffness relative to its weight. Because low weight is such an important consideration in aircraft structures, NASA has undertaken a variety of activities intended to resolve problems involved in applying these composite materials to aircraft structures. NASA activities include laboratory studies, as well as major projects to get flight experience with composites in secondary and primary structures on commercial aircraft. However, because of their low density, small diameter, and high electrical conductivity, graphite fibers raise issues beyond those normally considered in structural design.

Since graphite fibers are electrical conductors, they can cause short circuits, equipment malfunctions, or possibly fires if they get into electrical equipment. Furthermore, because of their low density and small diameter, graphite fibers can remain airborne for considerable time, and hence can be transported from the scene of an accident to the site of electrical or electronic equipment^{1,2}. NASA has underway a project to study, and if possible, to quantify the risk associated with this electrical hazard. While no definitive results from this risk assessment study will be available for some time, NASA has initiated exploratory investigations of alternate materials which can reduce electrical hazards and yet retain or enhance currently available graphite fiber composites properties.

On March 22 and 23, 1978, NASA Langley Research Center held a workshop to display the current program on alternate materials, to solicit approaches other than those being investigated, and to stimulate further thinking about possible materials solutions to eliminate a possible electrical hazard. At the workshop, a brief overview of the risk assessment activity was provided. This overview was not intended to be complete or definitive, nor was the workshop intended to address risk issues except from the point of view of alternate materials which would tend to reduce risk. After the risk overview, Langley, Lewis, and Ames Research Centers presented summaries of programs and plans to explore alternate materials. Following these summaries, test methods currently used to study accidental graphite fiber release were outlined. After the discussion of test methods, attendees divided into six working groups.

The workshop had working groups on epoxy modifications, epoxy replacement, fiber modifications, fiber coatings and new fibers, hybrids, and fiber release testing. These working

groups began with prepared presentations in their topic areas. Then they considered a set of issues that had been defined in advance. After further deliberations, the working groups prepared reports, guided by a recommended format, which were presented to all attendees. For each working group, two NASA employees were assigned as reporters, and they provided summaries of the activities of the groups.

The purpose of this document is to provide to attendees and other interested persons as much information as is likely to be useful and can be readily compiled. No text is available for any of the presentations. The information contained in this document includes copies of vugraphs used in presenting NASA programs, vugraphs summarizing working group findings, and NASA reporters' accounts of working group activities. Also included are an attendance list, and issues directed to each group. While care has been exercised in compiling this information, editing has been minimal and the source of the information should be consulted before taking further action. Furthermore, the reporter's accounts of the working group proceedings reflect the reporter's view of a dynamic process, and the opinions expressed may not reflect the considered judgement of the individuals involved or of their sponsoring institutions.

1. A Report of Observed Effects on Electrical Systems of Airborne Carbon/Graphite Fibers. NASA TM 78652, 1978.
2. Intergovernmental Committee, Compilers: Carbon Fiber Study. NASA TM 78718, 1978.

ORIGINAL PAGE IS
OF POOR QUALITY
ORIGINAL PAGE IS
OF POOR QUALITY

ORIGINAL PAGE IS
OF POOR QUALITY

AGENDA

MODIFIED COMPOSITE MATERIALS WORKSHOP

March 23-24, 1978
NASA-Langley Research Center
Hampton, Virginia

Thursday, March 23

8:00 a.m.	Registration	
8:30	Welcome	Richard R. Heldenfels NASA-Langley
	Workshop Expectations	William A. Brooks, Jr. NASA-Langley
	Potential Graphite Fiber Problems	Vernon L. Bell NASA-Langley
	Review of NASA-Langley Materials Modification Program	
	Overview	Robert T. Swann NASA-Langley
	Improved High Modulus Fibers	R. J. Diefendorf Rensselaer Polytechnic Institute
	Graphite Fibers with High Elec- trical Resistivity	F. Lincoln Vogel Un. of Pennsylvania
	Silicon Carbide, Boron, and Glass Coated Graphite Fibers	Francis Galasso United Technologies Research Center
	Boron Carbide and Silicon Car- bide Coated Graphite Fibers	Raymond Suplinskas AVCO Corporation
	Boron Nitride, Silicon Carbide and Silicone Coated Graphite Fibers	Herbert F. Volk Union Carbide Corporation
10:35-10:50	BREAK	
10:50	Review of NASA-Ames Materials Modification Program	
	An Approach to the Development of Fire Resistant Composites	John A. Parker NASA-Ames
	Preliminary Test Results of the Fiber Release Characteristics of Baseline Graphite Epoxy Compos- ites Compared with New Char Forming Analogs	Joseph Mansfield NASA-Ames
	Review of NASA-Lewis Materials Modifi- cation Program	Titc T. Serafini NASA-Lewis
12:10-1:10	LUNCH - NASA Cafeteria (B-1213) Private Dining Room	

1:10 p.m.	Fiber Release Testing Facilities and Results	Vernon L. Bell NASA-Langley
1:40	Charge to Working Groups	
1:50	Working Groups Convene (6 concurrent meetings)	
	I. Graphite Fiber Modification R. J. Diefendorf, Chairman Rensselaer Polytechnic Institute	STAGE
	II. Graphite Fiber Coating and Alternative Fibers James Economy, Chairman IBM Research Laboratory	HAMPTON ROOM
	III. Epoxy Resin Modifications James Noland, Chairman American Cyanamid Company	SUN LOUNGE
	IV. Epoxy Resin Replacements B. F. Landrum, Chairman Ciba-Geigy Corporation	MAIN LOUNGE
	V. Hybrid Composites Karl Prewo, Chairman United Technologies Research Center	WYTHE ROOM
	VI. Fiber Release Simulation Testing E. Bruce Belason, Chairman AVCO Corporation	LANGLEY ROOM
2:00-3:00	Coffee or Soft Drinks will be available in Main Lounge	
5:00	Working Groups Recess Buses depart for Holiday Inn	
6:00	Buses depart Holiday Inn for Sam's Seafood Restaurant	
6:15	Cash Bar Social	
7:00	Dinner	

Friday, March 24

8:00 a.m.	Working Groups Reconvene
9:45	BREAK
10:00	Reassemble for Working Group Reports
12:30 p.m.	Closing Remarks
12:45	Buses depart for Patrick Henry International Airport and Holiday Inn

WORKSHOP EXPECTATIONS

WILLIAM A. BROOKS, JR.
MARCH 23, 1978

MODIFIED COMPOSITE MATERIALS WORKSHOP
NASA LANGLEY RESEARCH CENTER
MARCH 23-24, 1978

OBJECTIVES

- o DISPLAY NASA PROGRAM ON MATERIALS MODIFICATIONS TO ALLEVIATE POTENTIAL ELECTRICAL PROBLEMS WITH GRAPHITE FIBER COMPOSITES
- o SOLICIT POSSIBLE SOLUTIONS TO THIS PROBLEM FROM THE COMPOSITE MATERIALS COMMUNITY
- o INITIATE A MORE GENERAL INVOLVEMENT OF THE COMPOSITES MATERIALS COMMUNITY IN APPROPRIATE ACTIVITIES

MODIFIED COMPOSITE MATERIALS WORKSHOP
NASA LANGLEY RESEARCH CENTER
MARCH 23-24, 1978

PARTICIPATION

	<u>INVITATIONS</u>	<u>ACCEPTANCES</u>
INDIVIDUALS (POLYMERS, FIBERS, FIRE TESTING)	149	111
COMMERCIAL COMPANIES	65	51
UNIVERSITIES	10	6
GOVERNMENT INSTALLATIONS	26	21

POTENTIAL

GRAPHITE FIBER PROBLEMS

8

V. L. BELL
3/23/78

GRAPHITE COMPOSITES

- o IMPORTANT LIGHTWEIGHT STRUCTURAL MATERIAL
- o USED CURRENTLY IN AEROSPACE, SPORTING GOODS
- o RAPID GROWTH PROJECTED

AEROSPACE: 1 MILLION LBS. (1990)

AUTOMOTIVE: 1 BILLION LBS. (1990)

CONSUMER PRODUCTS: 1 MILLION LBS. (1990)

- o MADE UP OF LIGHT GRAPHITE FIBERS IN POLYMER MATRIX

USES OF CF COMPOSITES ON COMMERCIAL AIRCRAFT

PRESENT

<u>SPOILERS:</u>	28 B-737's WITH 4 SPOILERS	- 13 LBS. CF/PLANE
<u>RUDDERS:</u>	7 DC-10's	- 30 LBS. CF/PLANE
<u>FLOORS:</u>	25 B-747's WITH CF/EPOXY FLOORS	

FUTURE

SECONDARY STRUCTURE

DC-10 RUDDER	40 LBS. CF
727 ELEVATOR	130 LBS. CF
L-1011 AILERON	70 LBS. CF

PRIMARY STRUCTURE

737 HORIZONTAL STABILIZER	125 LBS. CF
DC-10 VERTICAL FIN	700 LBS. CF
L-1011 VERTICAL FIN	700 LBS. CF

CHARACTERISTICS OF GRAPHITE FIBERS

- HIGH MODULUS ($\sim 50 \times 10^6$ PSI)
- DIAMETER (~ 8 MICRONS)
- FALL RATE (~ 2 CM/SEC)
- RESISTIVITY ($\sim 1000 \Omega$ - CM)
- FIBER BURNOUT 0.5 TO 1 WATT/CM (~ 10 TO 30 MA)
- CONTACT VOLTAGE DROP (~ 2 TO 5 VOLTS)

EFFECT OF MODULUS ON RESISTIVITY

12

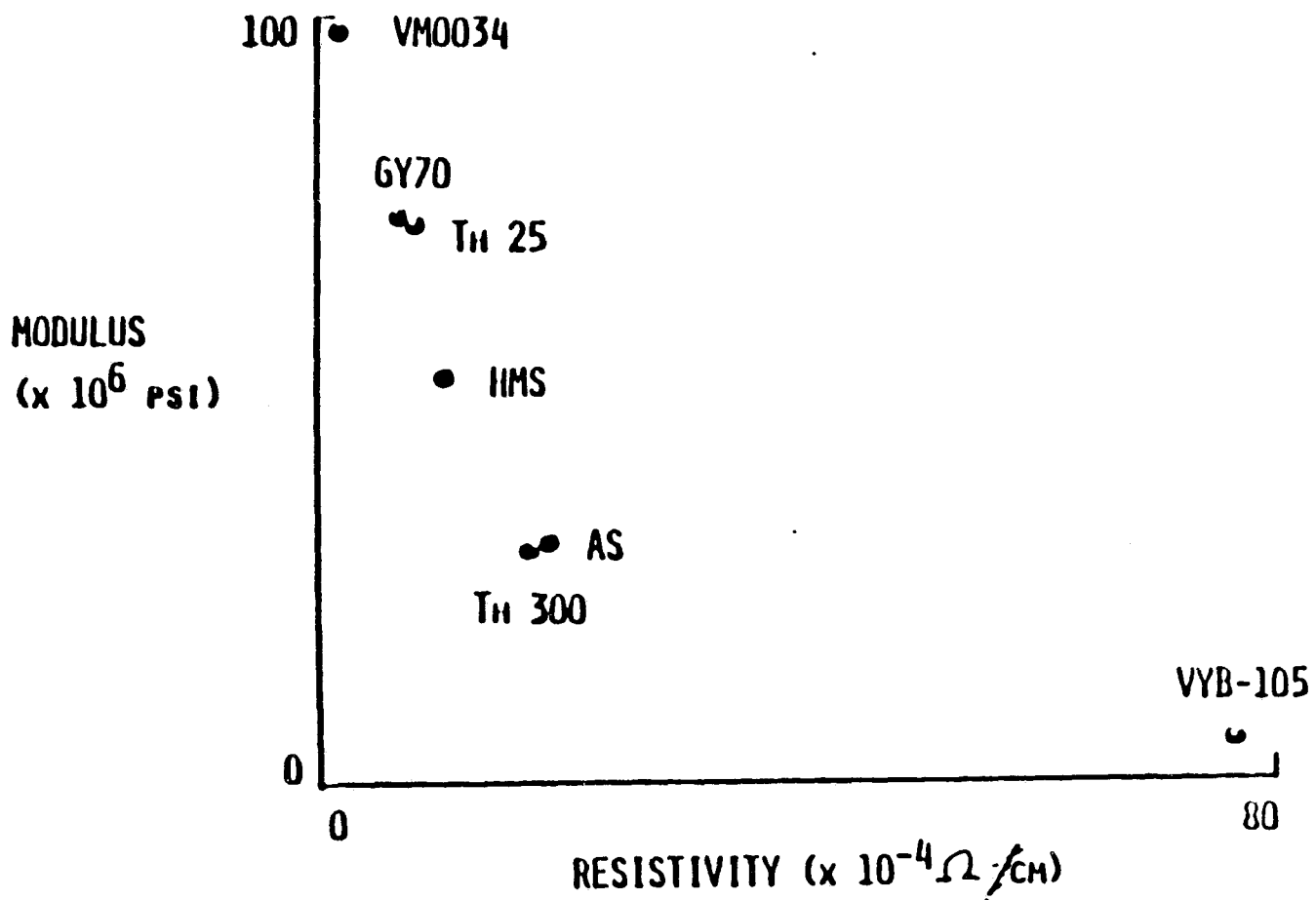

SUMMARY OF ELECTRICAL EFFECTS WITH GRAPHITE FIBER

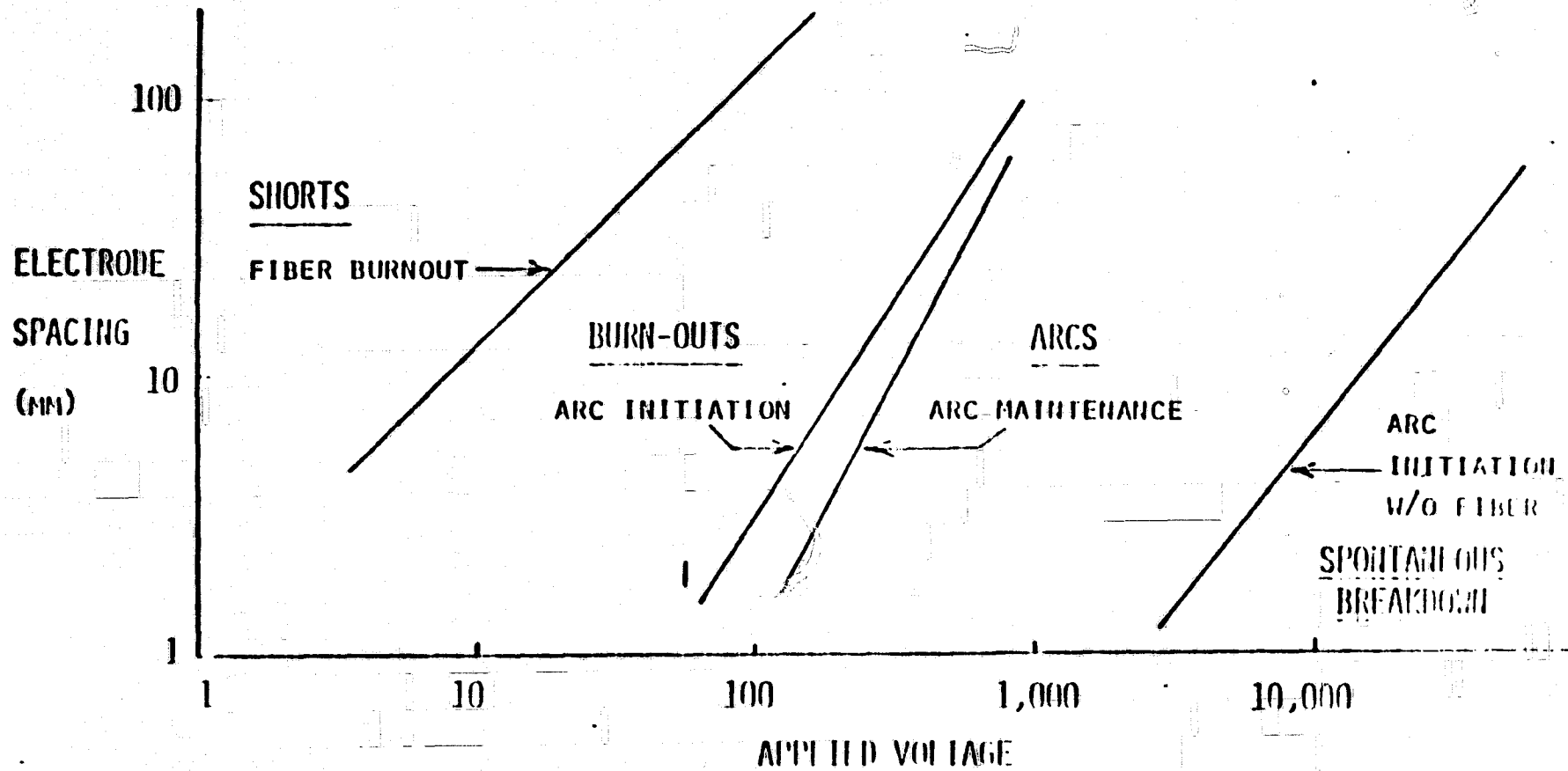

TYPES OF ACCIDENTAL RELEASE

- CRASH AND FIRE
- INDUSTRIAL OPERATIONS
- SCRAP/WASTE DISPOSAL
- INCINERATION OF USED PRODUCTS
- TESTING

RISK ANALYSIS FOR GRAPHITE STRUCTURES
OBJECTIVES

SHORT TERM

ESTABLISH LEVEL OF CONFIDENCE IN METHODS AND RESULTS

QUANTIFY NEAR TERM RISK OF GRAPHITE FIBER ON CURRENT CIVIL AIRCRAFT

LONG TERM

QUANTIFY RISKS ASSOCIATED WITH ACCIDENTAL RELEASE OF GRAPHITE FIBERS FROM
AERONAUTICAL USES OF COMPOSITES IN THE FUTURE

QUANTIFY REDUCTION IN RISKS ASSOCIATED WITH USE OF MODIFIED MATERIALS

RISK ANALYSIS FLOW

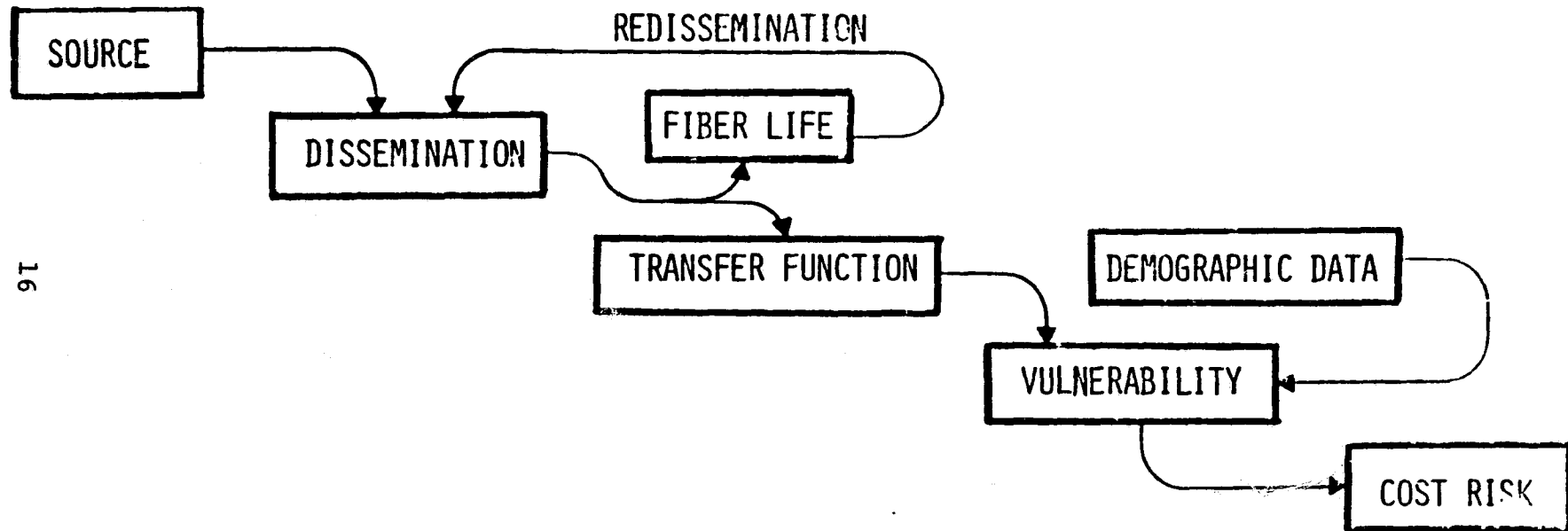

SOURCE PARAMETERS

AIRCRAFT ACCIDENT AND FIRE STATISTICS

AIRCRAFT ACCIDENT AND FIRE LOCATIONS

FIRE ENERGY CONTENT AND RATE

FIRE FIGHTING EFFECTS

QUANTITY AND LENGTHS RELEASED

17

ORIGINAL PAGE IS
OF POOR QUALITY

DISSEMINATION PARAMETERS

ATMOSPHERICS

STABILITY

WIND

INVERSION HEIGHT

WEATHER

FALL VELOCITY OF FIBER

LENGTH DEPENDENCE

LOCAL EFFECTS

FIRE PLUME

TURBULENCE, VORTICES

BUILDINGS, TREES

LIFE AND REENTRAINMENT

TRANSFER FUNCTION PARAMETERS

PARAMETERS: FIBER LENGTH
FIBER FALL VELOCITY
LOCAL VELOCITY
SEASON (DOORS, WINDOWS, CANOPIES)
CASE OPENING AREA

REQUIRED FOR: BUILDINGS, ROOMS, AIRCRAFT, EQUIPMENT RACKS,
AIR CONDITIONING, FILTERS . . .

VULNERABILITY

USER CLASSIFICATIONS:

HOME APPLIANCES

COMMERCIAL

MANUFACTURE

PUBLIC SERVICE

POLICE, FIRE, COMMUNICATIONS

AIRCRAFT

TYPE CLASSIFICATIONS:

MOTORS

AMPLIFIERS

CONTROLLERS

RADARS

MATERIAL RELEASE CHARACTERISTICS

BURN AND EXPLODE CHAMBER TESTS

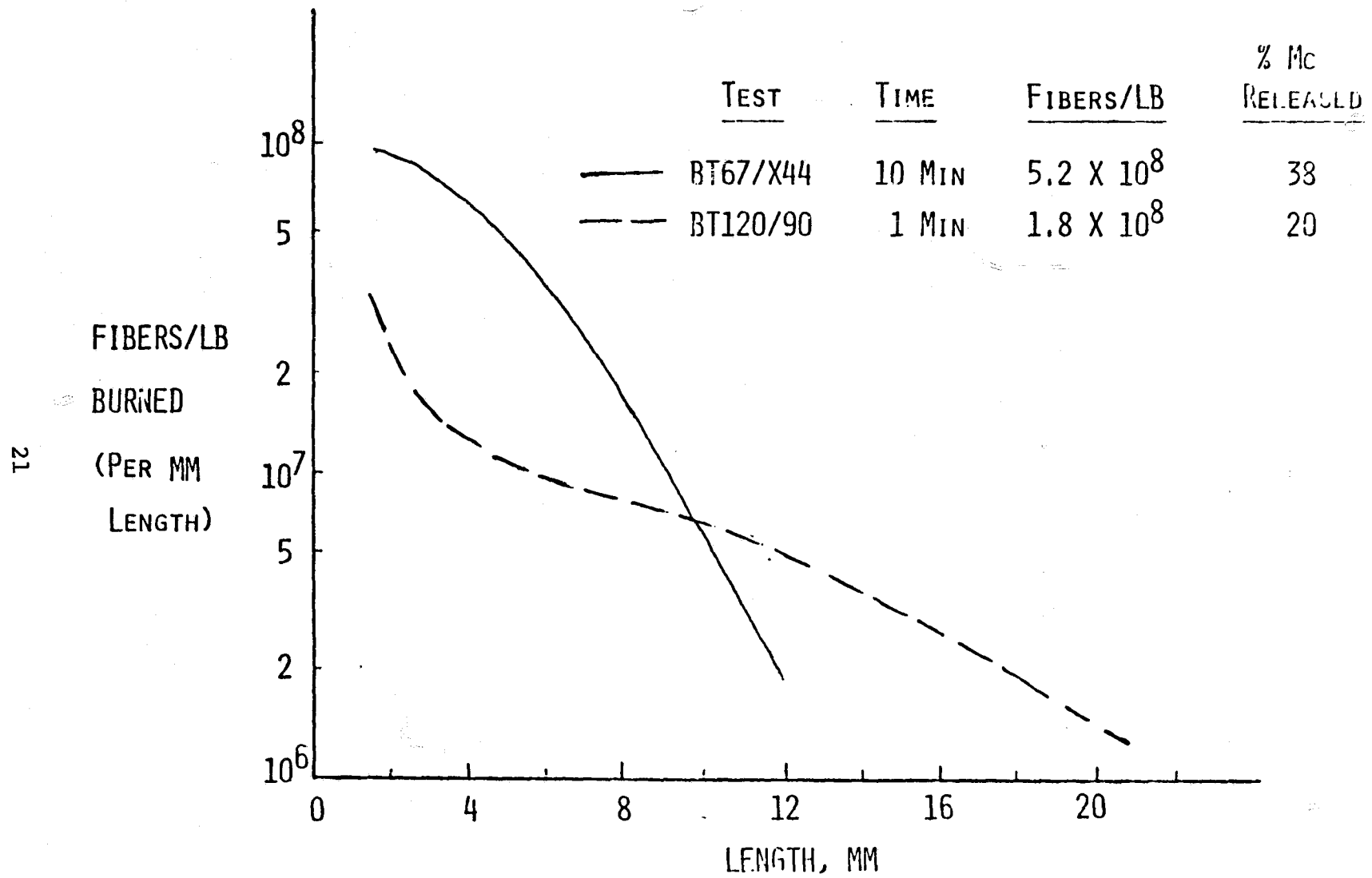

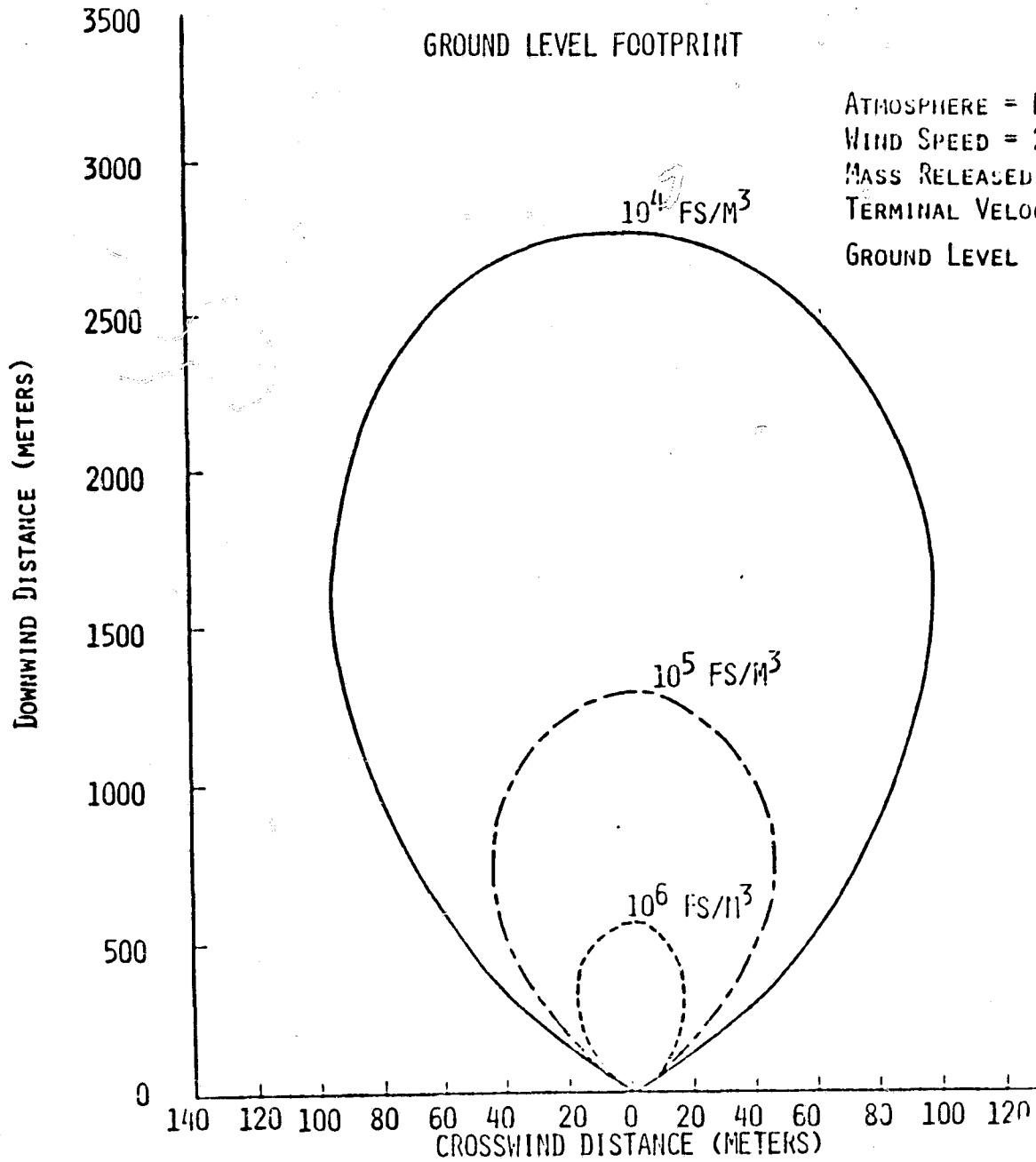

ATMOSPHERE = F
WIND SPEED = 2 M/S
MASS RELEASED = 13.6 KG (30 LBS.)
TERMINAL VELOCITY = 0.032 M/S
GROUND LEVEL RELEASE

FAILURE EXPOSURE LEVELS FOR CIVILIAN EQUIPMENT

23 EXPOSURE,
F-SEC.^{1/3}

ORIGINAL PAGE IS
OF POOR QUALITY

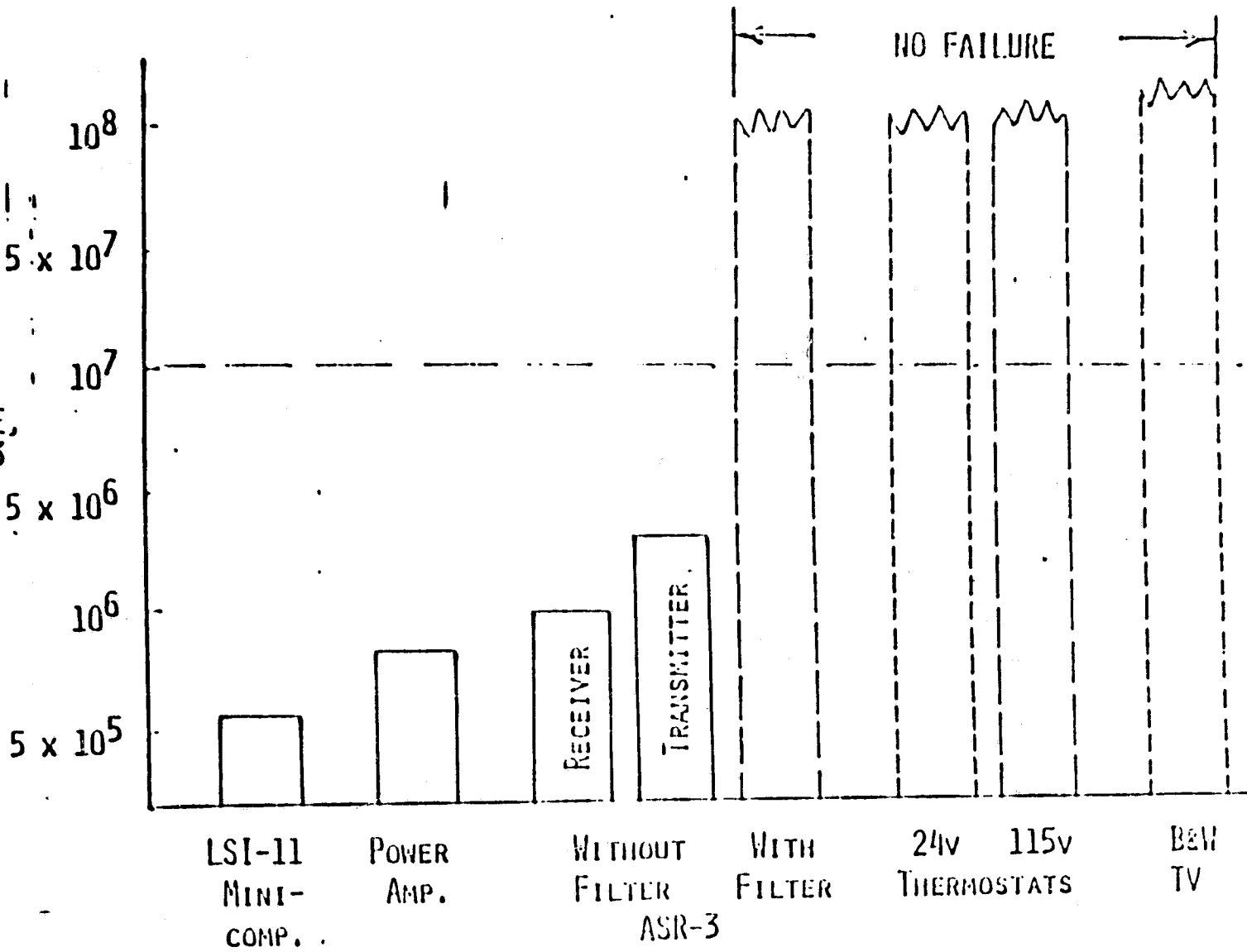

NO FAILURE

CONCLUSIONS

1. PRELIMINARY COMPUTATIONS INDICATE THE RISK IS NEITHER NEGLIGIBLE NOR OF HIGH MAGNITUDE, HOWEVER,
2. INSUFFICIENT DATA IS AVAILABLE TO ADEQUATELY COMPUTE THE MAGNITUDE OF THE RISK
3. FURTHER WORK IS REQUIRED:
 - A. TEST DATA IS REQUIRED ON SOURCES, TRANSFER FUNCTION AND VULNERABILITY
 - B. MODELLING FOR THESE FACTORS IS REQUIRED
 - C. METHODOLOGY FOR COMPUTING AND PREDICTING RISK NEEDS DEVELOPMENT

OVERVIEW

NASA LANGLEY MATERIALS MODIFICATION PROGRAM

ROBERT T. SWANN
MARCH 23, 1978

IMPROVED MATERIALS FOR STRUCTURAL COMPOSITES

LANGLEY RESEARCH CENTER PROGRAM

PRIMARY PROGRAM

0 FIBER MODIFICATIONS

RPI

U. PA - MERADCOM

0 FIBER COATINGS

UTRC

AVCO

UNION CARBIDE

SECONDARY PROGRAM

0 ALTERNATE FIBERS (BN)
SOURCE PENDING

0 HYBRIDS

0 RESIN MODIFICATIONS

IMPROVED MATERIALS FOR STRUCTURAL COMPOSITES

HYBRIDS AND RESIN MODIFICATIONS

OBJECTIVE: SCREEN HYDBRIDS AND RESIN MODIFICATIONS TO DETERMINE WHICH ONES
REDUCE FIBER RELEASE

APPROACH: EVALUATE HYBRIDS

- 0 OUTER PLIES WITH S-GLASS AND E-GLASS FIBERS
- 0 OUTER PLIES WITH BORON FIBERS
- 0 METAL CLADDING
- 0 ADD SEALING GLASS

EVALUATE RESIN MODIFICATIONS

- 0 NCNS: EPOXY
- 0 XYLOK: EPOXY
- 0 SILICONE: EPOXY
- 0 HEXCEL 178 PI

IMPROVED MATERIALS FOR STRUCTURAL COMPOSITES

ALTERNATE FIBERS

OBJECTIVE: DEVELOP HIGH STRENGTH, HIGH MODULUS BORON NITRIDE FIBERS

- APPROACH:
- o COOPERATE WITH NAVY TO EXTEND USAF-INITIATED DEVELOPMENT OF BN FIBERS
 - o DEVELOP TECHNICAL PLAN WHICH ADDRESSES CRITICAL PROBLEMS IDENTIFIED IN PRIOR WORK

IMPROVED HIGH MODULUS FIBER

R. J. DIEFENDORF
RENSSELAER POLYTECHNIC INSTITUTE

MARCH 23, 1978

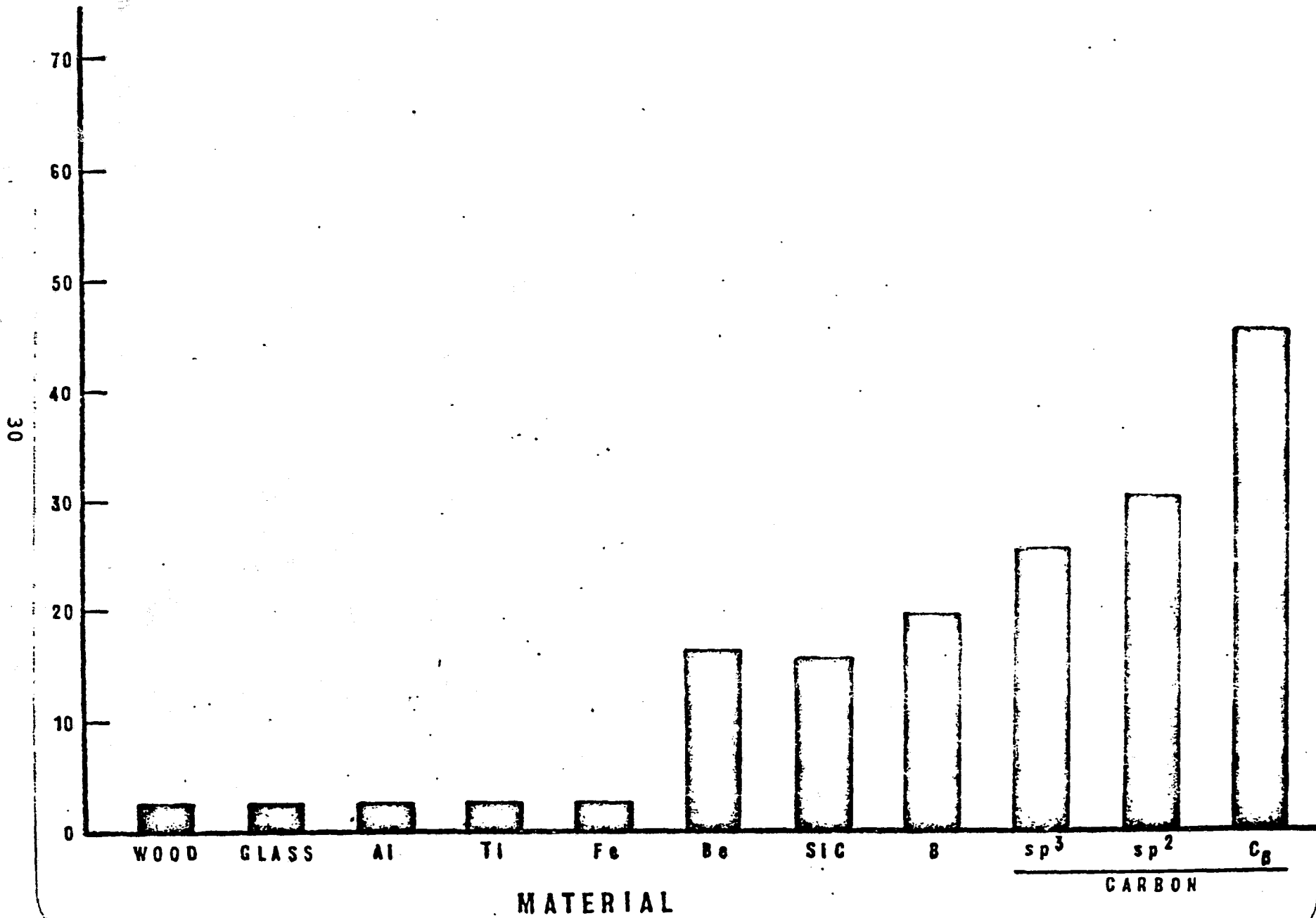

LADDER POLYMERS

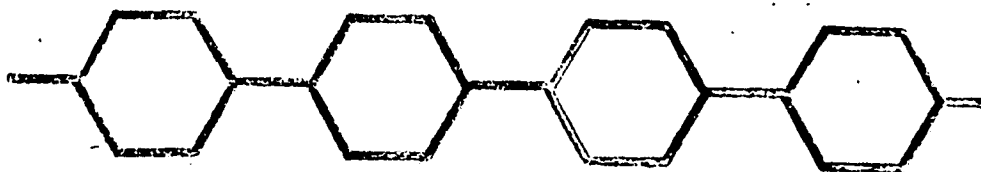
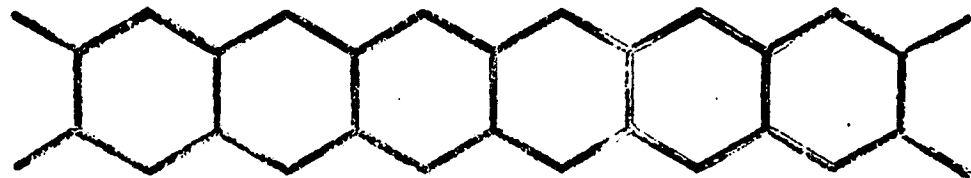

- 1) M.P. TOO HIGH
- 2) INSOLUBLE

KEVLAR

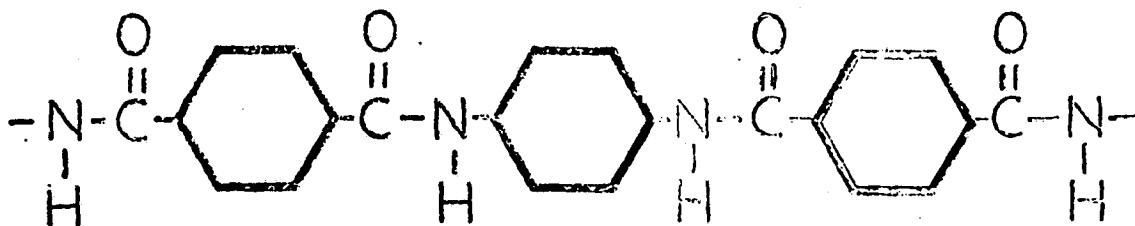

- 1) AMIDE GROUPS MAKE SOLUBLE
- 2) FORMS L.C.

RAYON BASE FIBERS

FIBER → STABILIZE → CARBONIZE → GRAPHITIZE

ORIENT

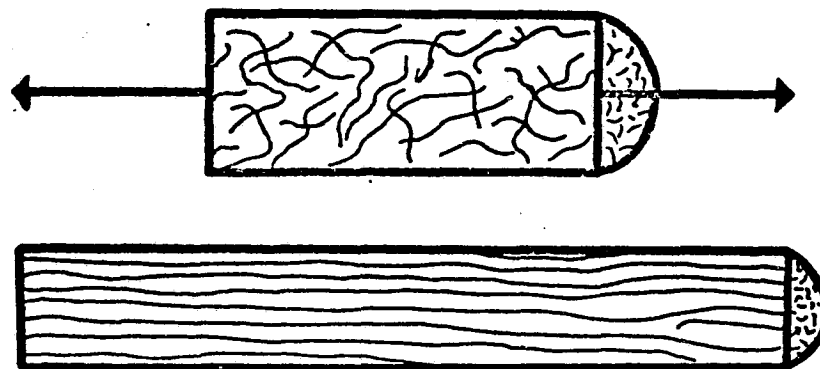

POLYACRYLONITRILE PROCESS

33

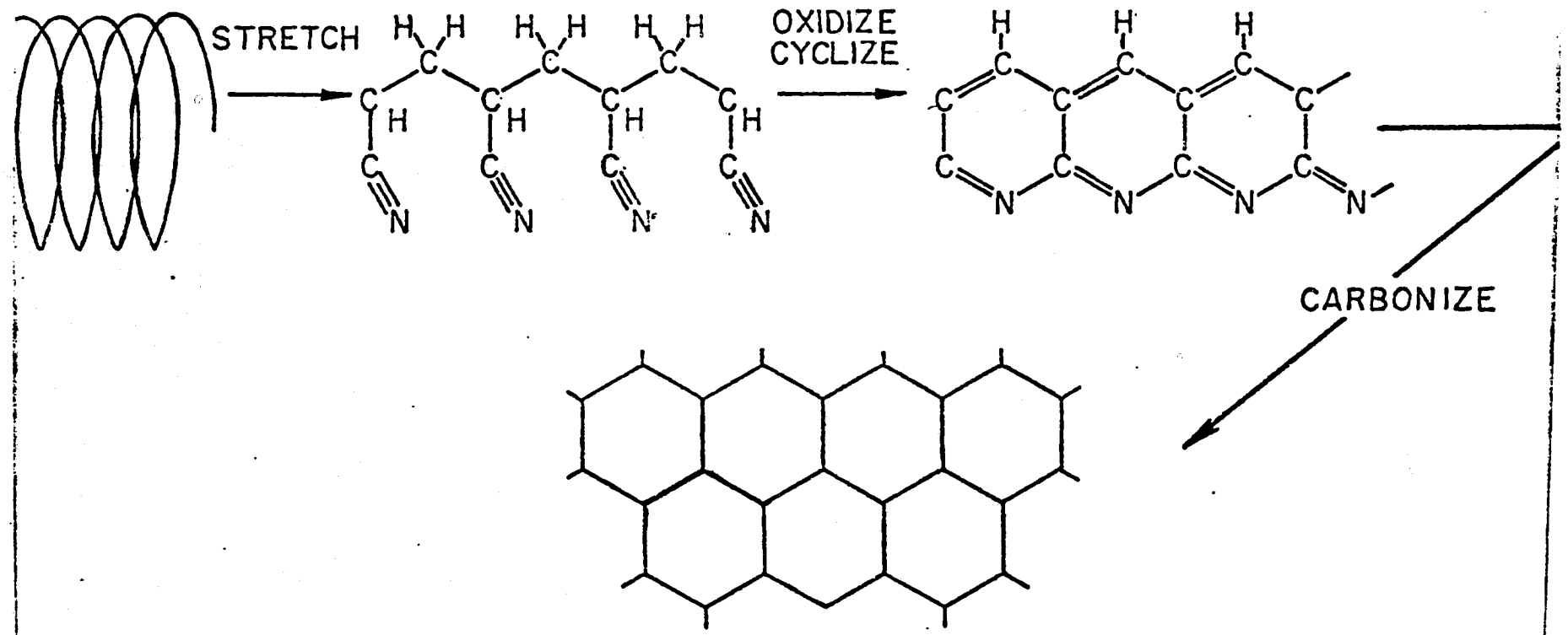

PITCH FIBERS 2

34

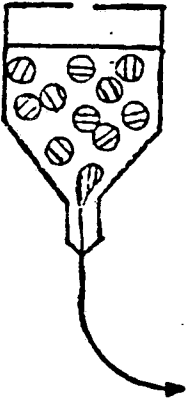
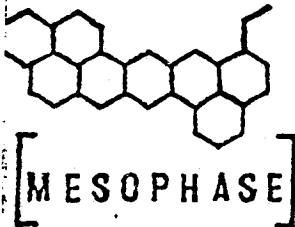

SPIN

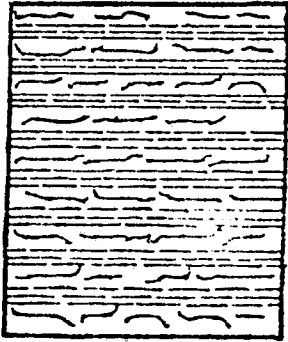

STABILIZE

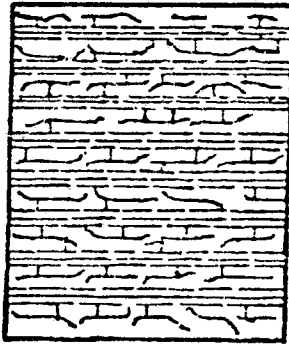

CARBONIZE
GRAPHITIZE



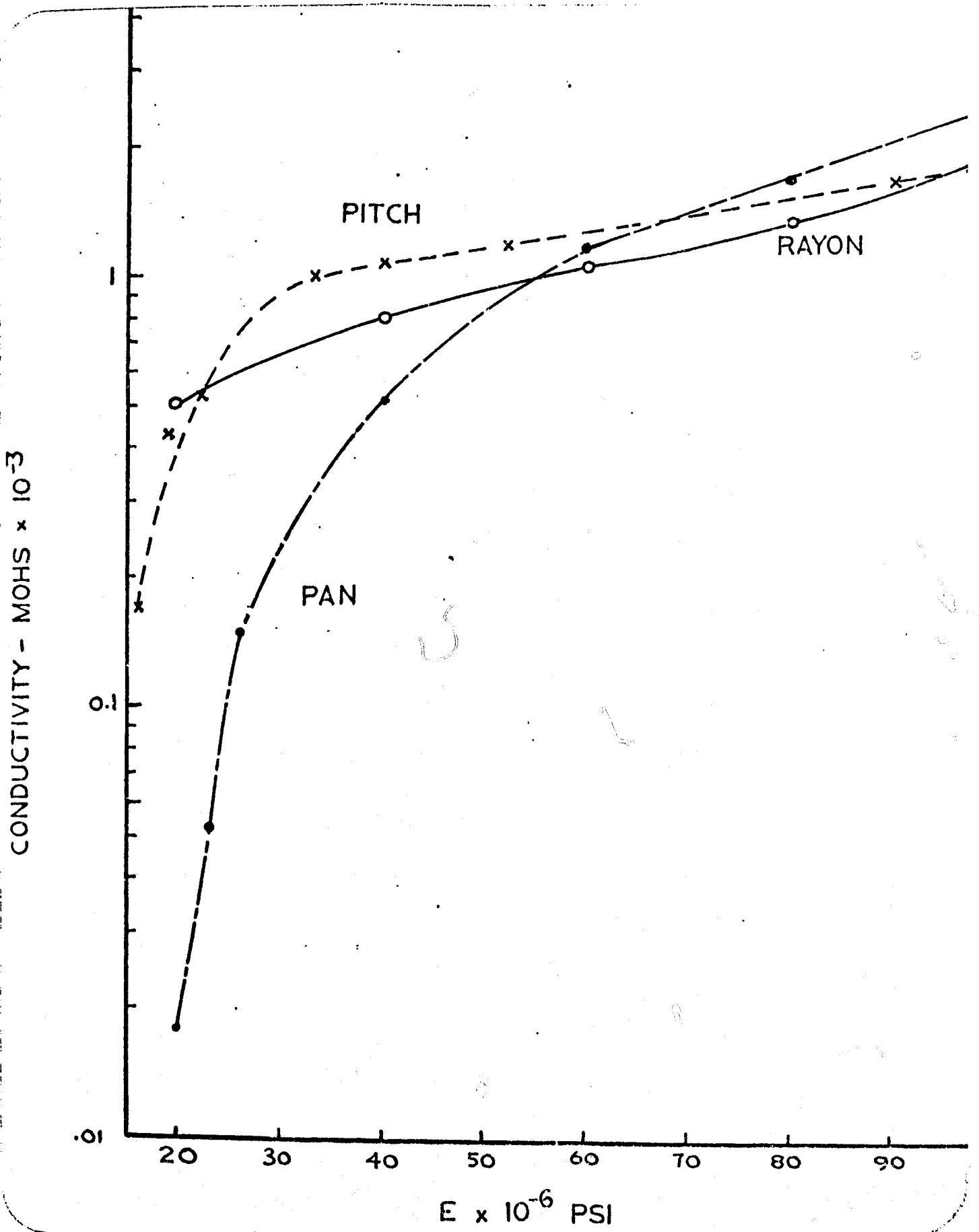

FIBER PROPERTIES

- PREFERRED ORIENTATION
- MICROSTRUCTURE
- ELASTIC CONSTANTS
- CRYSTALLITE SIZE

ORIGINAL PAGE IS
OF POOR QUALITY

FIBER PREFERRED ORIENTATION

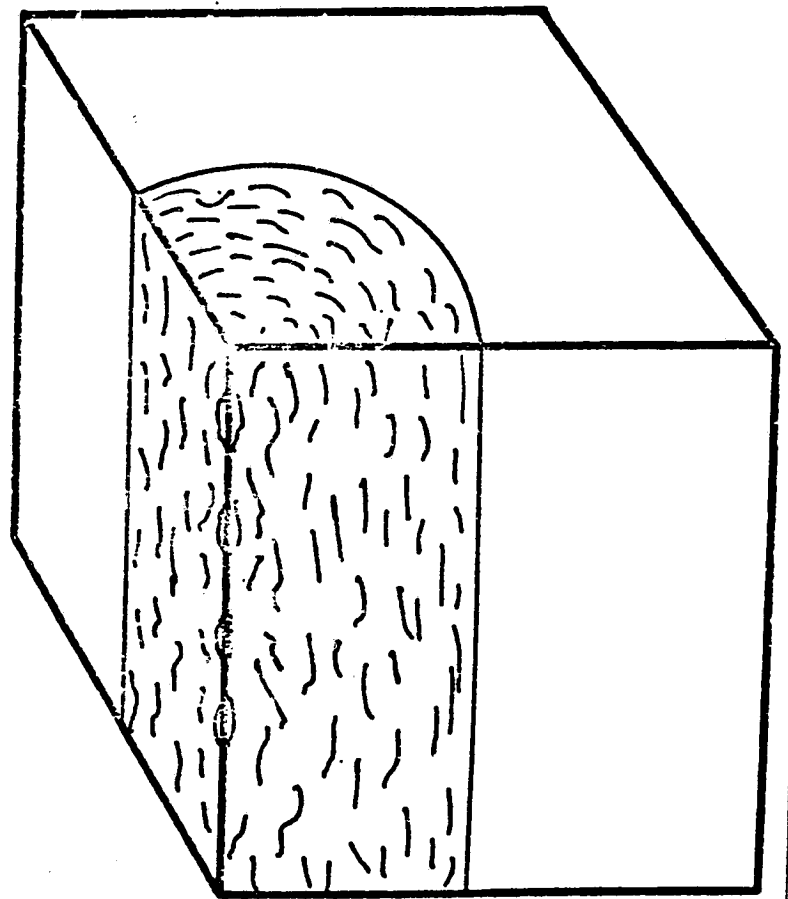
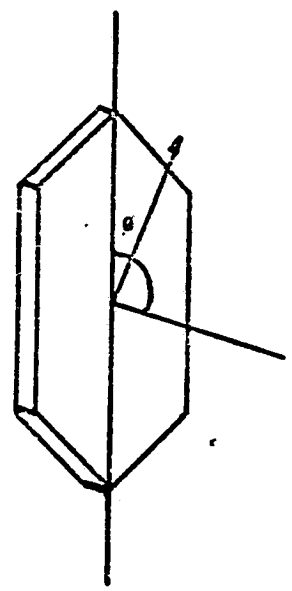
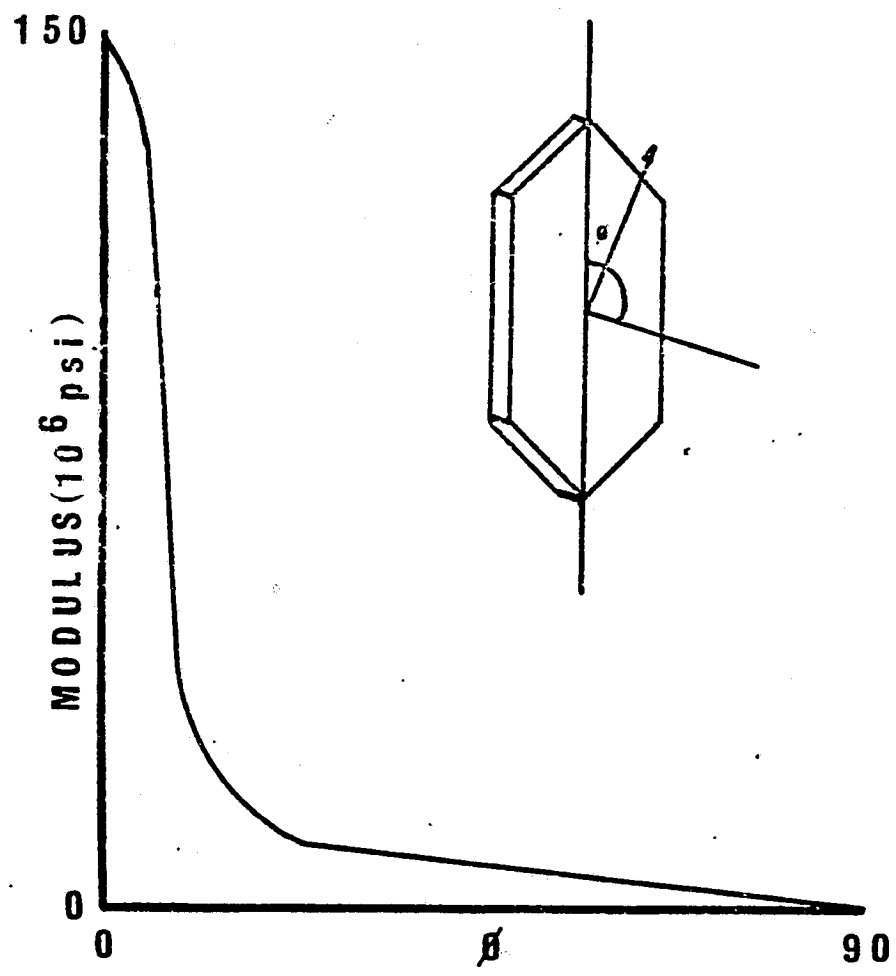

37

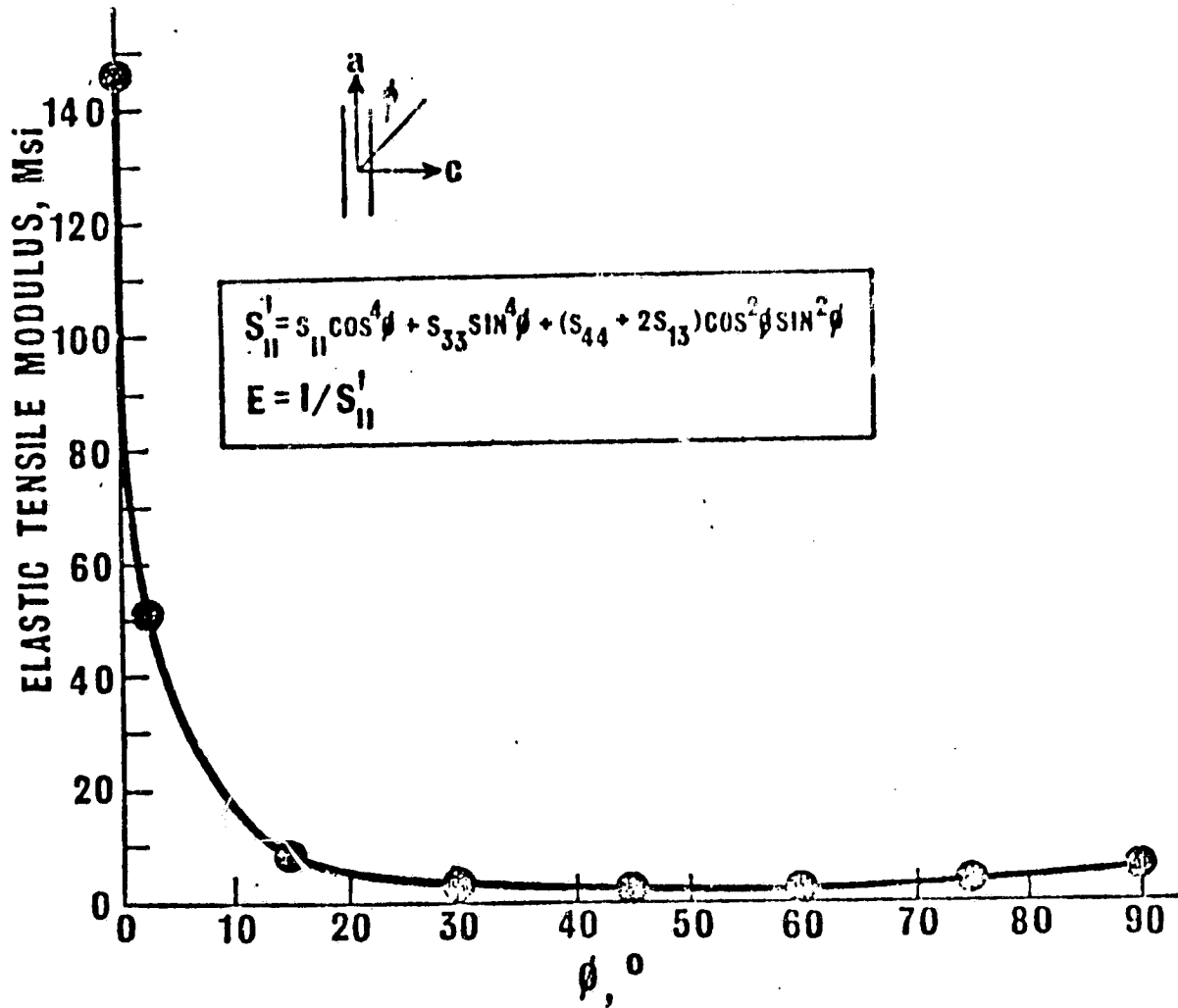

**ORIGINAL PAGE IS
OF POOR QUALITY**

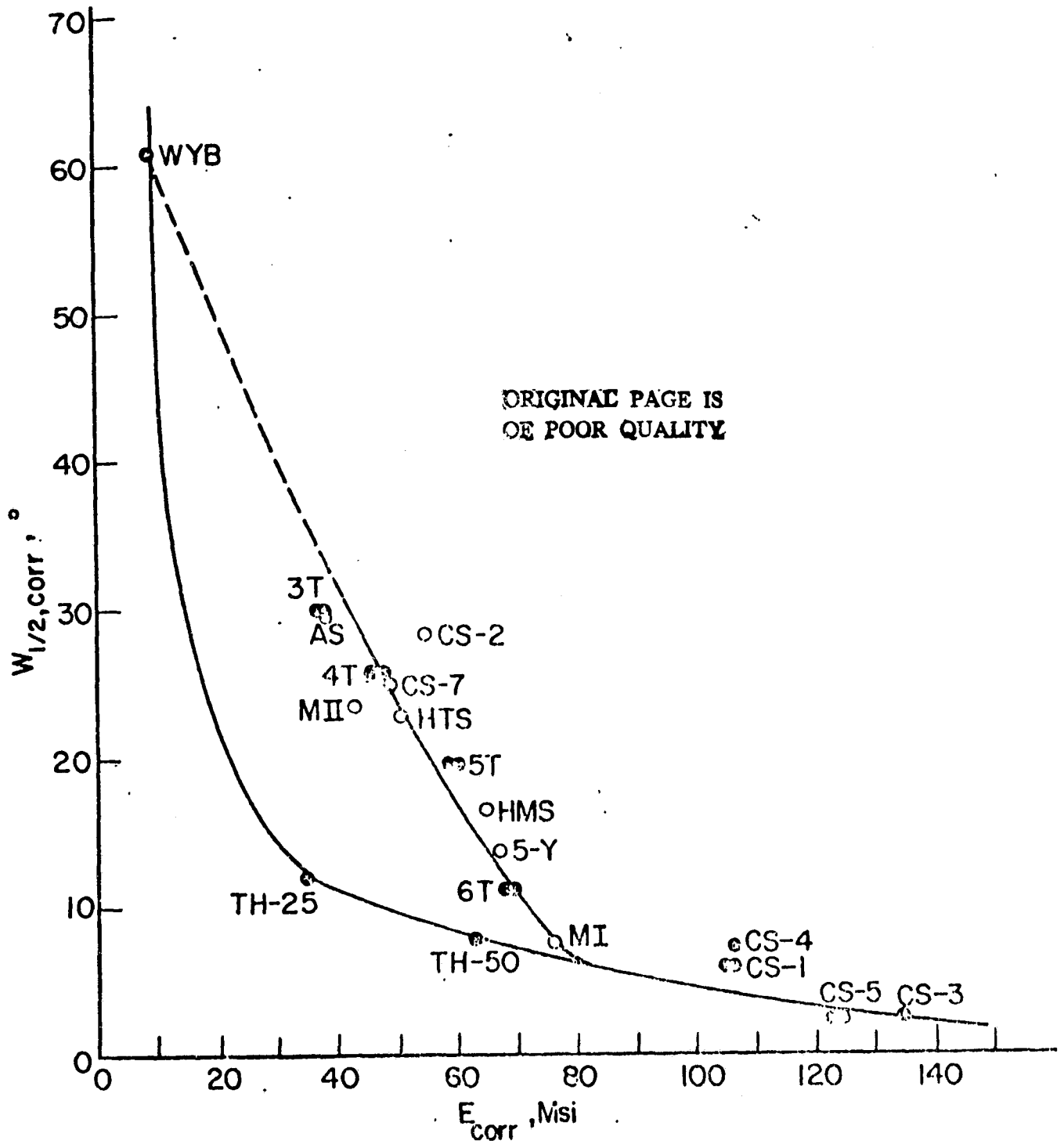

Index of Preferred Orientation, $W_{1/2}$ vs. Fiber Modulus

TOP

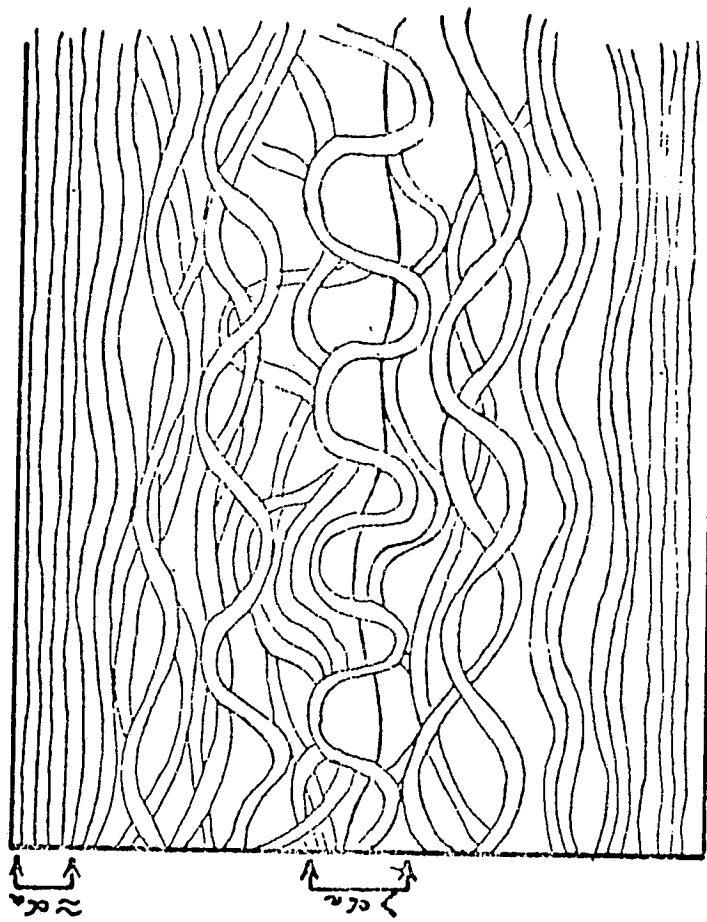

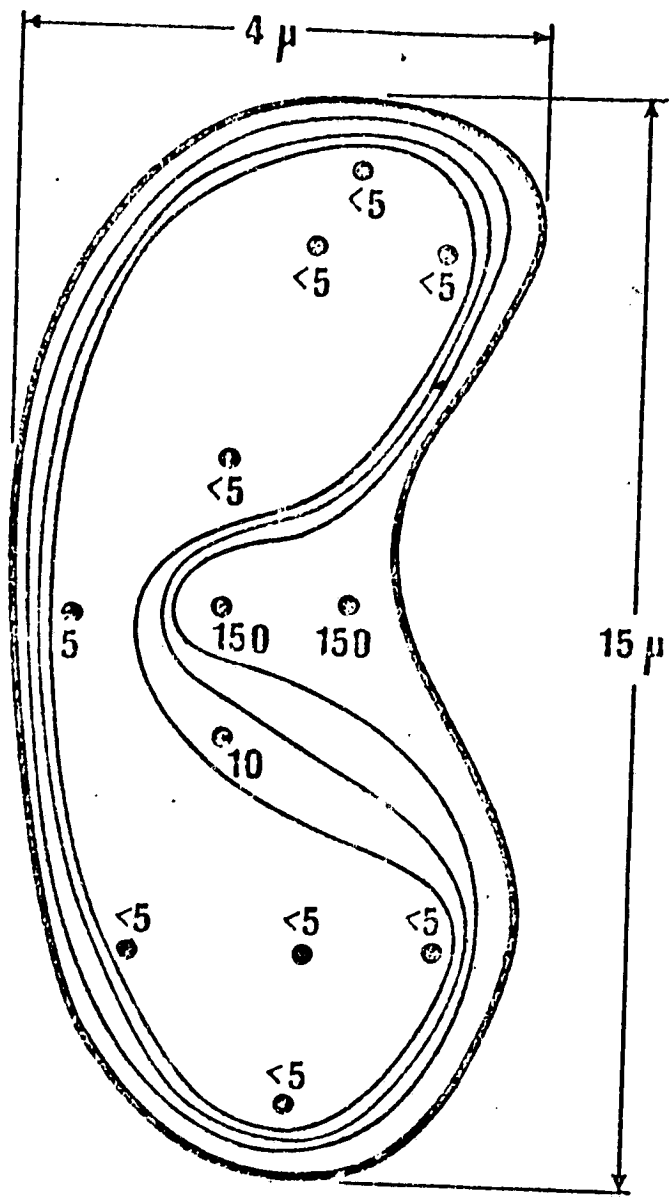

NUMBERS REPRESENT AXIAL MODULI VALUES
(IN MSI) OVER THE CROSS SECTION OF THE FIBER.

ORIGINAL PAGE IS
OF POOR QUALITY

TOP

LOW TEMPERATURE DEFECTS
(WORK WITH PAN AND PITCH)

- . ORIENTATION
- . RELAXATION
 - OXIDATION
 - CARBONIZATION
- . FIBRIL SIZE - LA AND Lc

FULLY EXTENDED P.E.

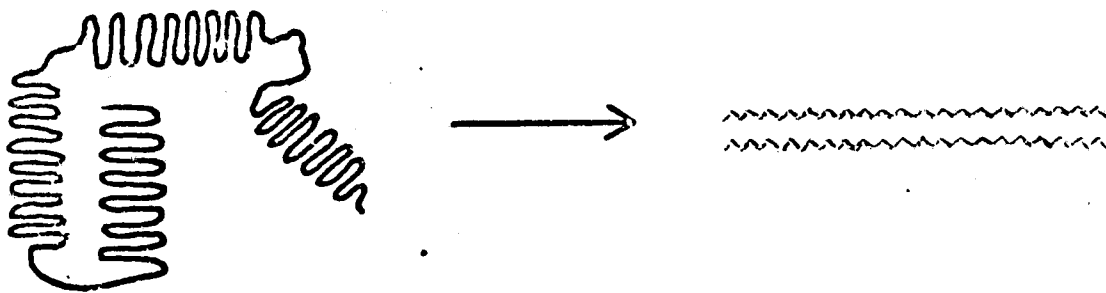

1. HYDROSTATIC EXTRUSION
2. WARM DRAWING
3. L.C. MELT EXTRUSION ?

ORIGINAL PAGE IS
OF POOR QUALITY

TOP

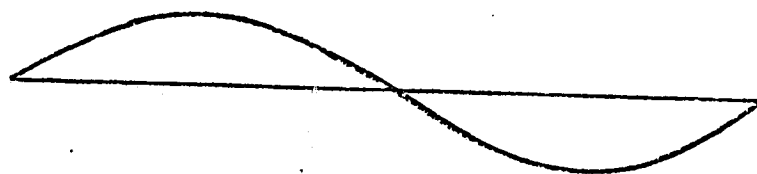
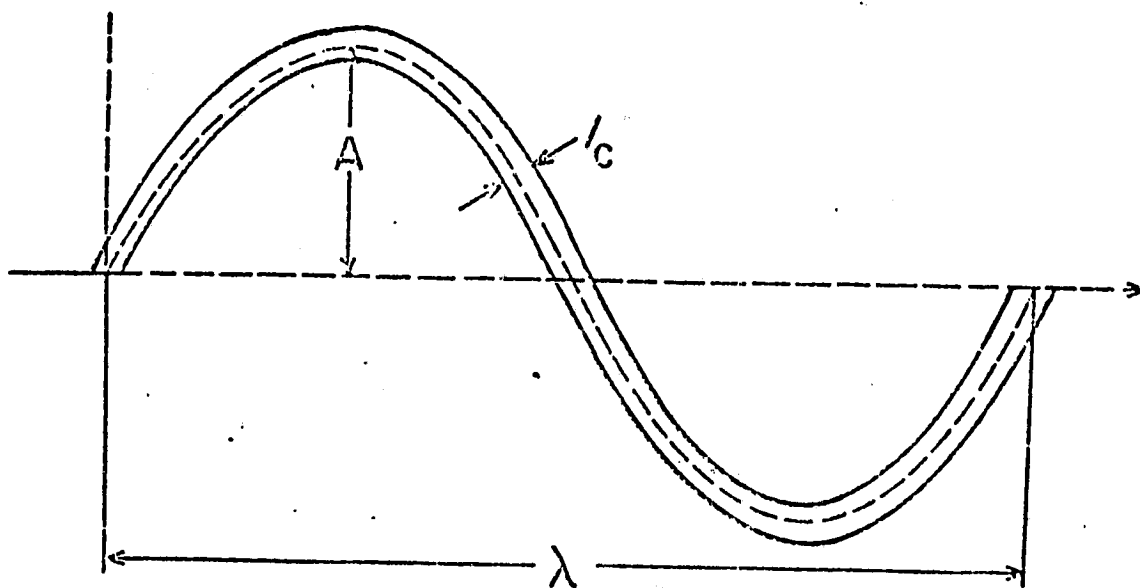

$$A/\lambda = 10^{-1}$$

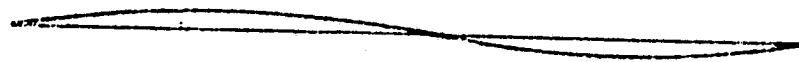

$$A/\lambda = 10^{-2}$$

RESISTIVITY

- . LOW TEMPERATURE - DEFECTS
- . NITROGEN TRAPS - PAN
- . BORON/NITROGEN/CARBON SOLID SOLUTION
- . INSULATING COATING -BN - SiC

<u>PROPERTY</u>	<u>BN</u>	<u>C</u>
MELTING POINT	2400°C (SUBL.)	3600°C (SUBL.)
THEOR. DENSITY	2.25	2.25
ELEC. RESIST. 25°C (OHM-CM)	$10^{13} - 10^{10}$	10^{-3}
THERM. EXP. COEF. 25°C $-\alpha_a$	1.8×10^{-6}	1.8×10^{-6}
THERM. EXP. COEF. 25°C $-\alpha_c$	45×10^{-5}	15×10^{-6}

A B S T R A C T

Graphite Fibers with High Electrical Resistivity

BY: F.L. Vogel⁺, Russell Eaton*, and W. David Lee*

Problems of arc over and circuit perturbation in electrical equipment have been traced to the presence of graphite fibers. A potential solution to this problem lies in increasing the electrical resistivity of the graphite fibers by several orders of magnitude. It is proposed herein that this may be accomplished by treating the fibers to form graphitic oxide. This treatment has the effect of inserting oxygen into the graphite lattice and increasing the resistivity considerably. The graphite layer planes remain largely unaffected and so the elastic modulus and tensile strength are predicted to be unchanged.

Supporting work in the literature will be reviewed.

⁺ Department of Electrical Engineering & Science
& Laboratory for Research on the Structure Matter
University of Pennsylvania
Philadelphia Pa., 19104

* Electrical Equipment Division
MERADCOM Fort Belvoir, Va. 22060

**ORIGINAL PAGE IS
OF POOR QUALITY**

INTERSTITIAL COMPOUND APPROACH

CAN CONVERSION OF GRAPHITE FIBER TO GRAPHITE
OXIDE (FLUORIDE) REDUCE ELECTRICAL CONDUCTIVITY
SIGNIFICANTLY WITHOUT DEGRADING MECHANICAL PROPERTIES?

SYNTHESIS

COMPOSITIONS

STRUCTURES

COVALENT BONDING = HIGH RESISTIVITY

AROMATIC RINGS = HIGH STRENGTH
AND MODULUS

ELECTRICAL RESISTIVITY

GRAPHITE OXIDE SYNTHESIS

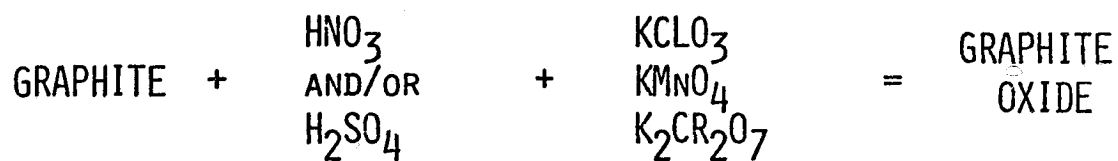

BRODIE, HOFFMAN, STAUDENMAIER

TIME CONSUMING, HAZARDOUS



HUMMERS AND OFFEMAN

RAPID REACTION - NO HAZARD

GRAPHITE OXIDE COMPOSITIONS

MIXTURES

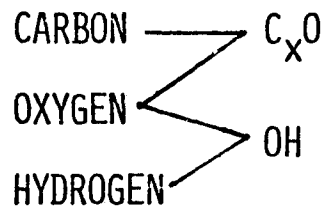

$x > 1, = 2 \text{ OR } 3$

<u>CARBON</u> <u>OXYGEN</u>	RATIO	COLOR
16		BLACK
3		GREEN
2		YELLOW

GRAPHITE OXIDE STRUCTURE

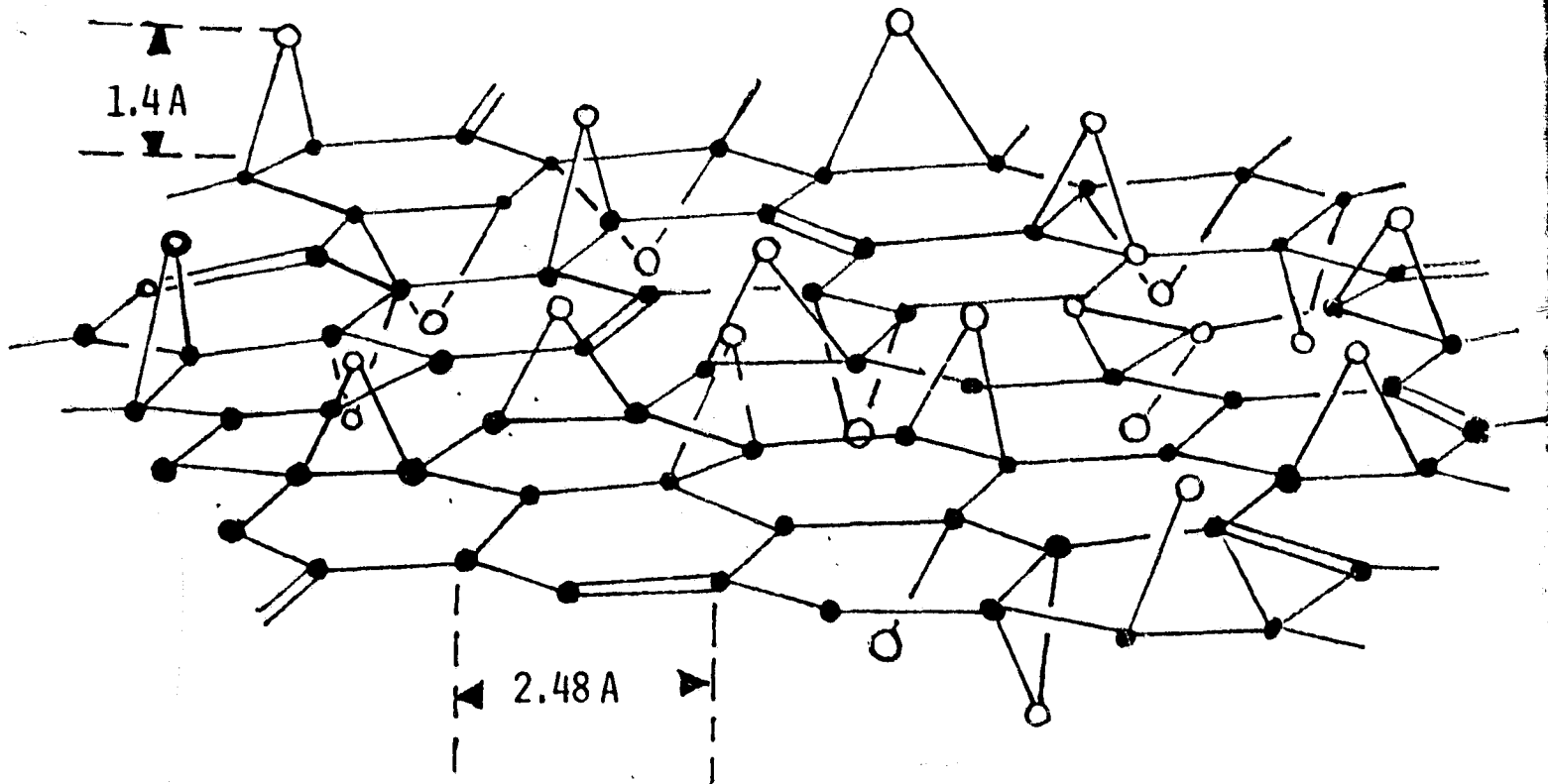

- OXYGEN ATOM
- CARBON ATOM

FROM HOFFMAN, FRENZL, CSALAN

GRAPHITE OXIDE STRUCTURE

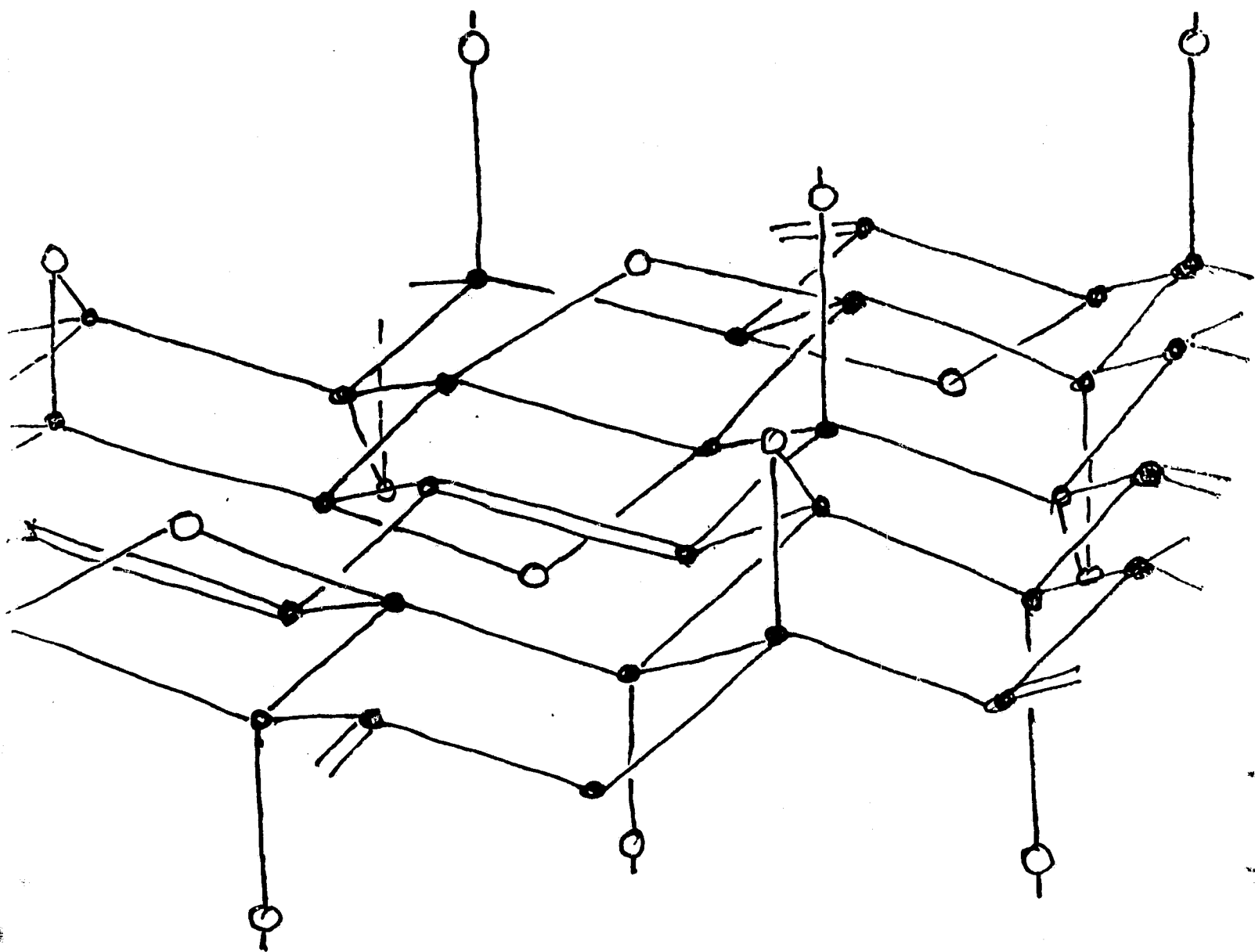

- OXYGEN ATOM
- CARBON ATOM

FROM CLAUSS, PLASS, BOEHM, HOFFMAN

GRAPHITE OXIDE ELECTRICAL RESISTIVITY

<u>CARBON</u> <u>OXYGEN</u>	RATIO	RESISTIVITY (DRY) OHM-CM
	3.0	10^7
	3.5	4,000
	4.3	250
	7.1	0.4
	12	0.2
	21	0.05
GRAPHITE		0.023

SILICON CARBIDE, BORON, AND GLASS
COATED GRAPHITE FIBERS

FRANCIS GALASSO
UNITED TECHNOLOGIES RESEARCH CENTER

MARCH 23, 1978

Fibers	%Loss in weight (600°C)		As received
	1 Hour	3 Hours	Modulus x 10 ⁶ psi
Hercules HTS	14.8	100.0	37
Hercules HMS	9.4	39.5	51
55 Celanese DG102	3.7	36.1	77
Thornel 50	3.2	16.7	57
Thornel type P	5.3	21.1	60

Fiber	%Loss in weight (550°C)		
	1 Hour	3 Hours	6 Hours
1 HMS	34.8	77.0	88.6
2 HMS	6.1	20.9	39.4
3 HMS	12.4	27.7	52.0
1 HTS	3.1	17.1	93.9
2 HTS	4.9	21.8	97.8
3 HTS	3.8	13.6	34.3
AS	78.3	—	—
T300	71.4	—	—

56

Graphite Fiber Coating Program

Molten glass

J. Bacon

Colloidal silica

S. Holmquist

Dip coating

Electrophoretic coating

Organo-silicon compounds

Dip and conversion

D. Scola
and
H. Roth

CVD SiC

R. Veltri
and
F. Galasso

CVD B

R. Veltri
and
F. Galasso

Material**Resistivity (ohm-cm)****SiC** $10^3 - 10^5$ **B** 7×10^3 **B₄C** 5×10^{-1} **TiC** 10^{-4} **BN** 10^{13} **Si₃N₄** 10^{17} **SiO₂** 10^{16}

58

Continuous Glass Coating Apparatus

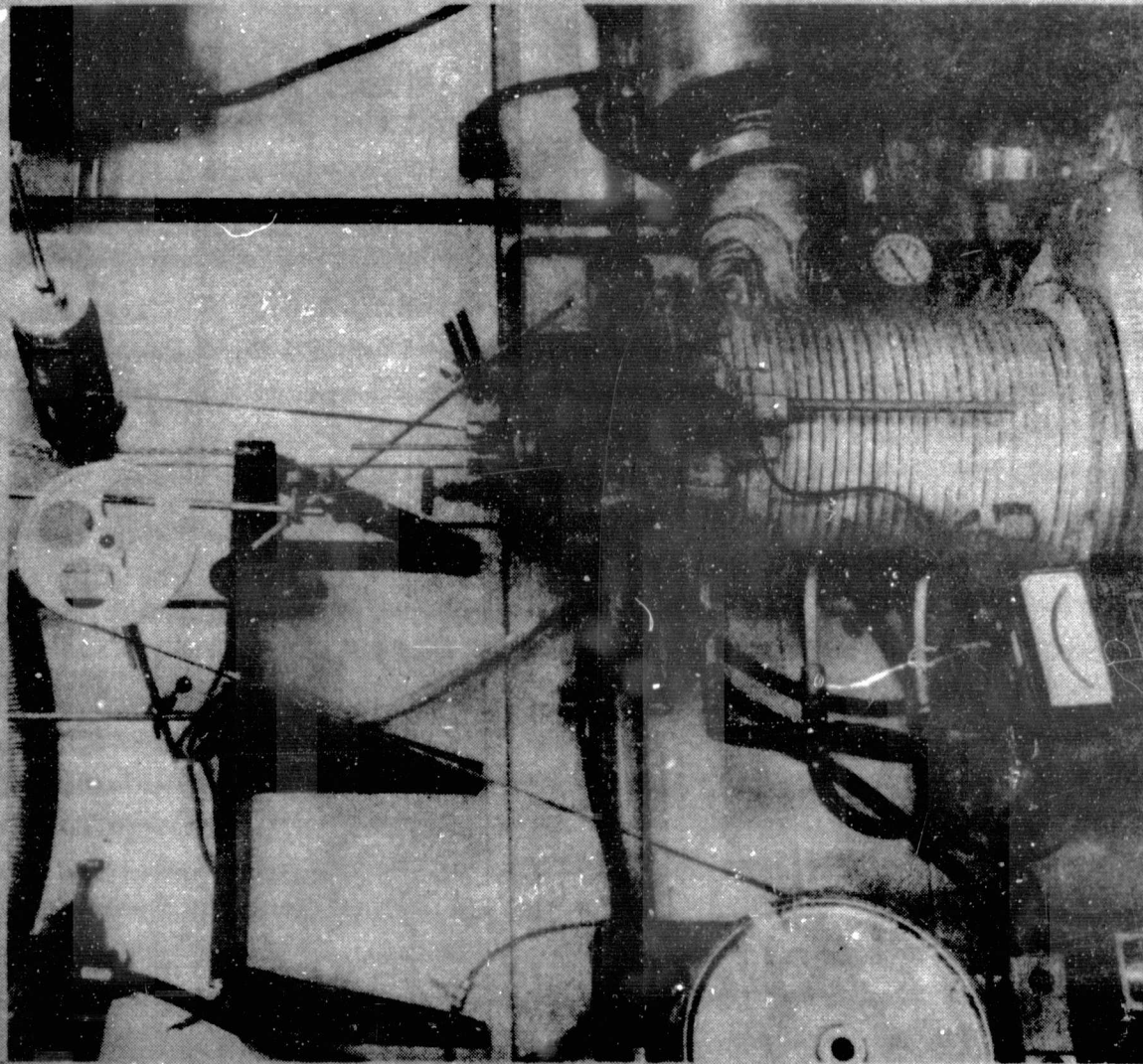

ORIGINAL PAGE IS
OF POOR QUALITY

Graphite Fiber Drawn Through E-Glass



ORIGINAL PAGE IS
OF POOR QUALITY

Colloidal SiO₂

(30%)

Dip Coating

Dilutions as received

1/2

1/4

1/9

1/20

1/50

1/100

Results

Crusty coating
(stiff)

Coating
not
observed



Voltage

10v

5v

3v

Electrophoresis

Results

Coating
with
O₂
given off at electrode

19

Organo-Silicon Coatings and Thermal Conversion

<u>Material deposited</u>	<u>Number of coats</u>	<u>EDAX analysis Si deposited/ Si background</u>
CH ₃ -Si-(OC ₂ H ₅) ₃ (methyltriethoxysilane)	1	Trace
	5	Trace
62 CH ₂ =CH-Si-O-C(=O)-CH ₃) ₃ (Vinyl triacetoxysilane)	1	230/100
	5	1250/100
Silicone resin G.E. SR 355	1	Trace
	5	1100/100
Ethyl silicate prepolymer	1	675/100
	5	2250/100

X-Ray Data for SiC Produced at Various Temperatures and Pressures

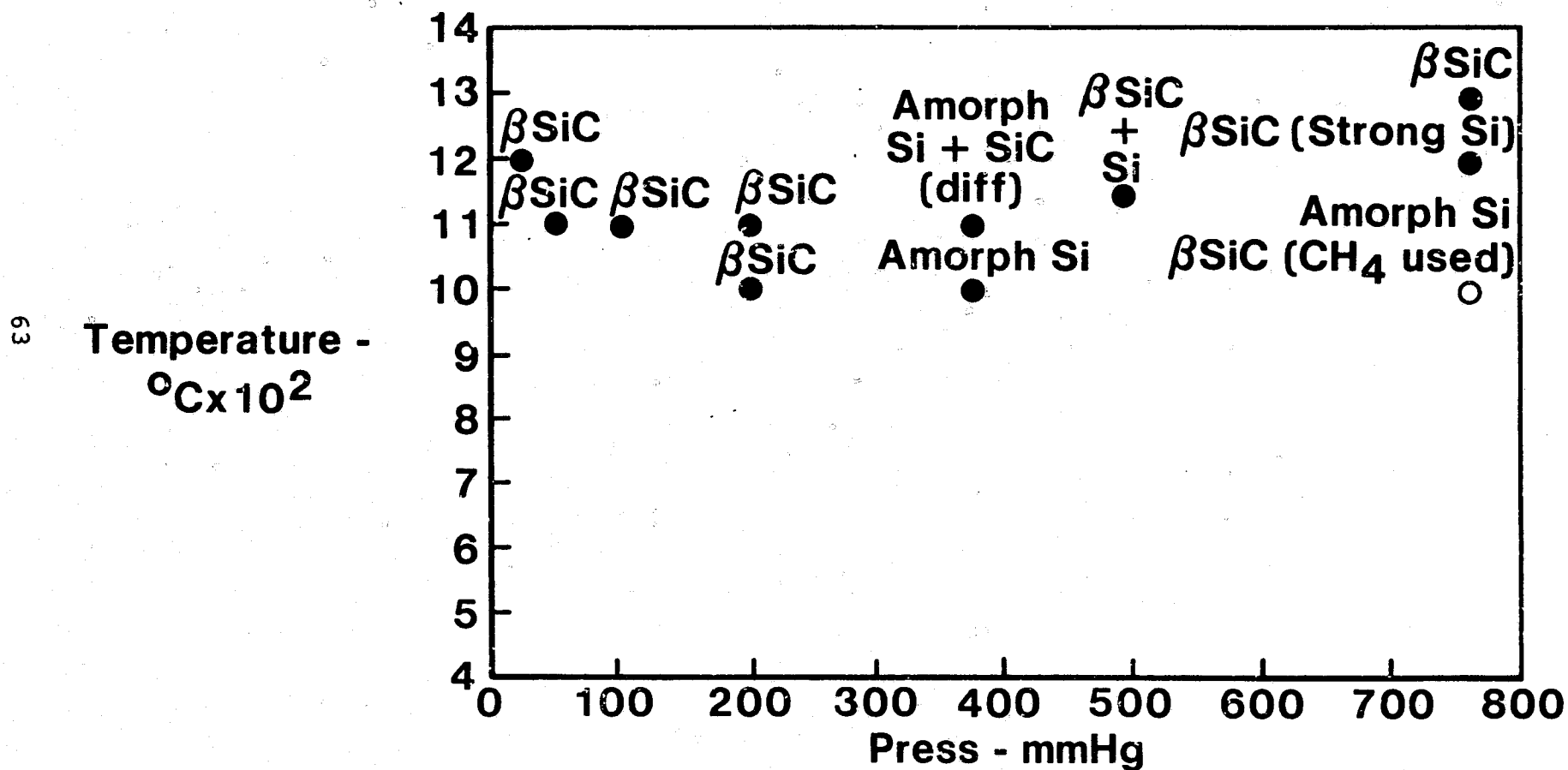

Thermal Profile in Reactor Zone for Four Power Levels

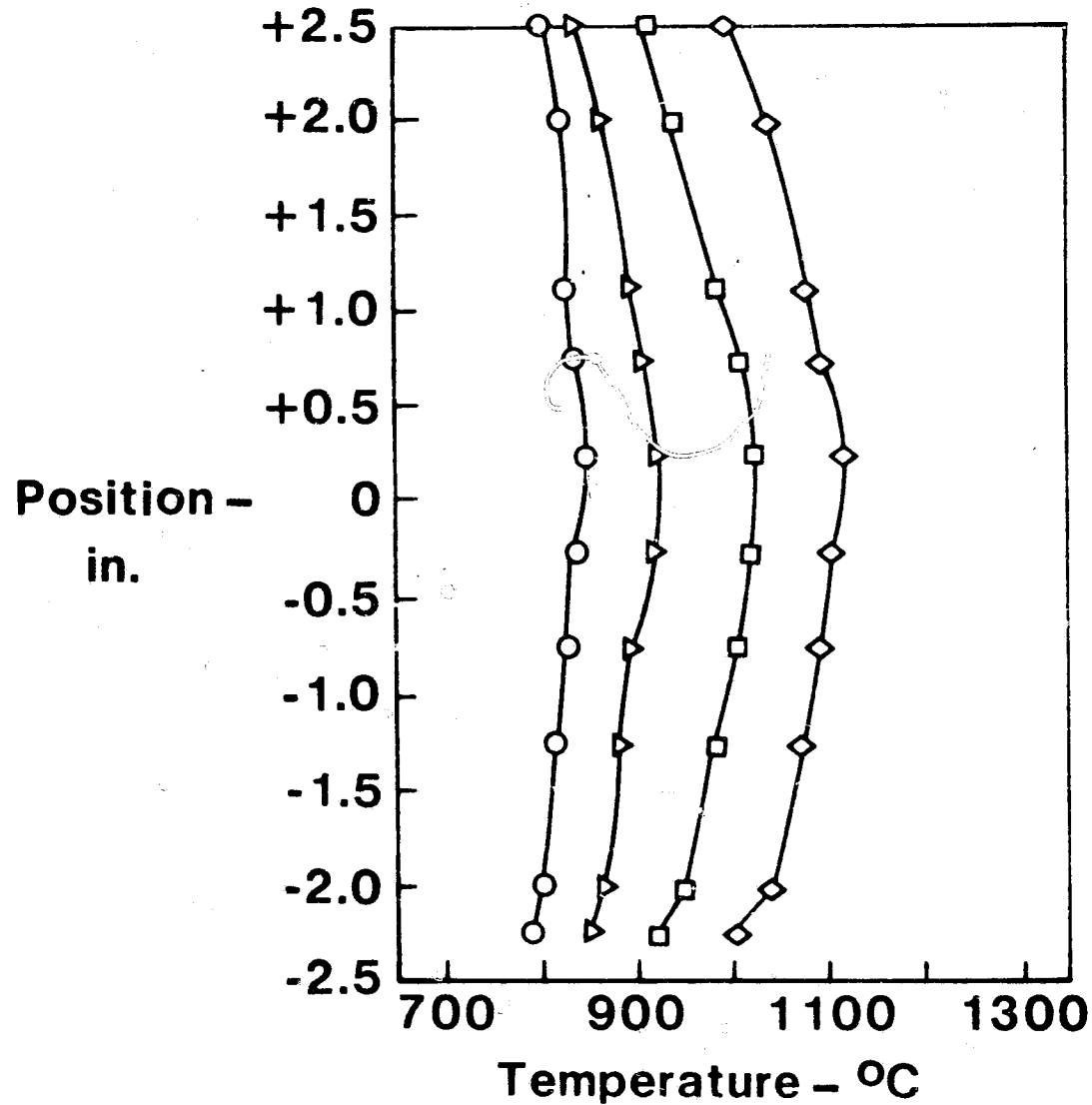

64

Silane Evaporator

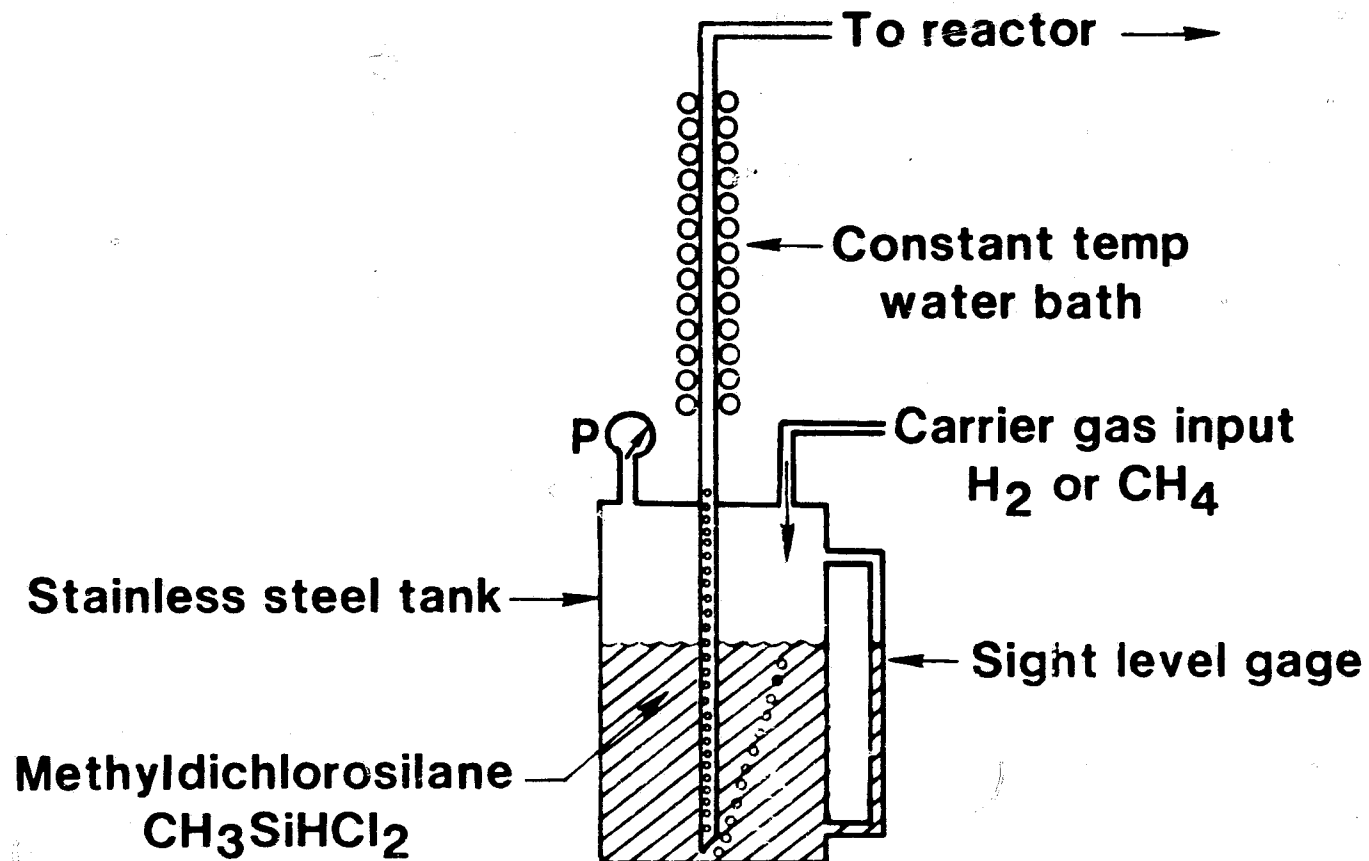

65

SiC on Graphite Fiber Static Run

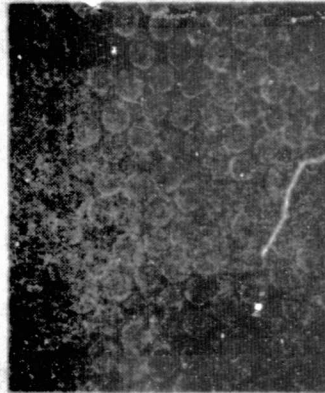

A 1/4 in. into graphite
susceptor

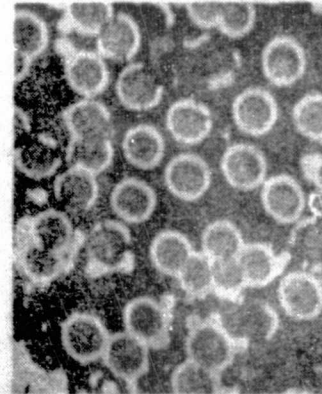

B 1 in. into graphite
susceptor

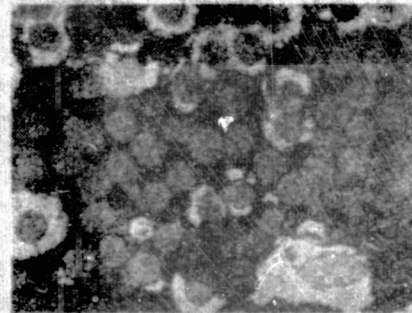

C 1/2 in. over graphite
susceptor

ORIGINAL PAGE IS
OF POOR QUALITY

96

Deposition Rate

Temp 1050°C

Atmospheric pressure

Static runs

Increase in radius
(microns)

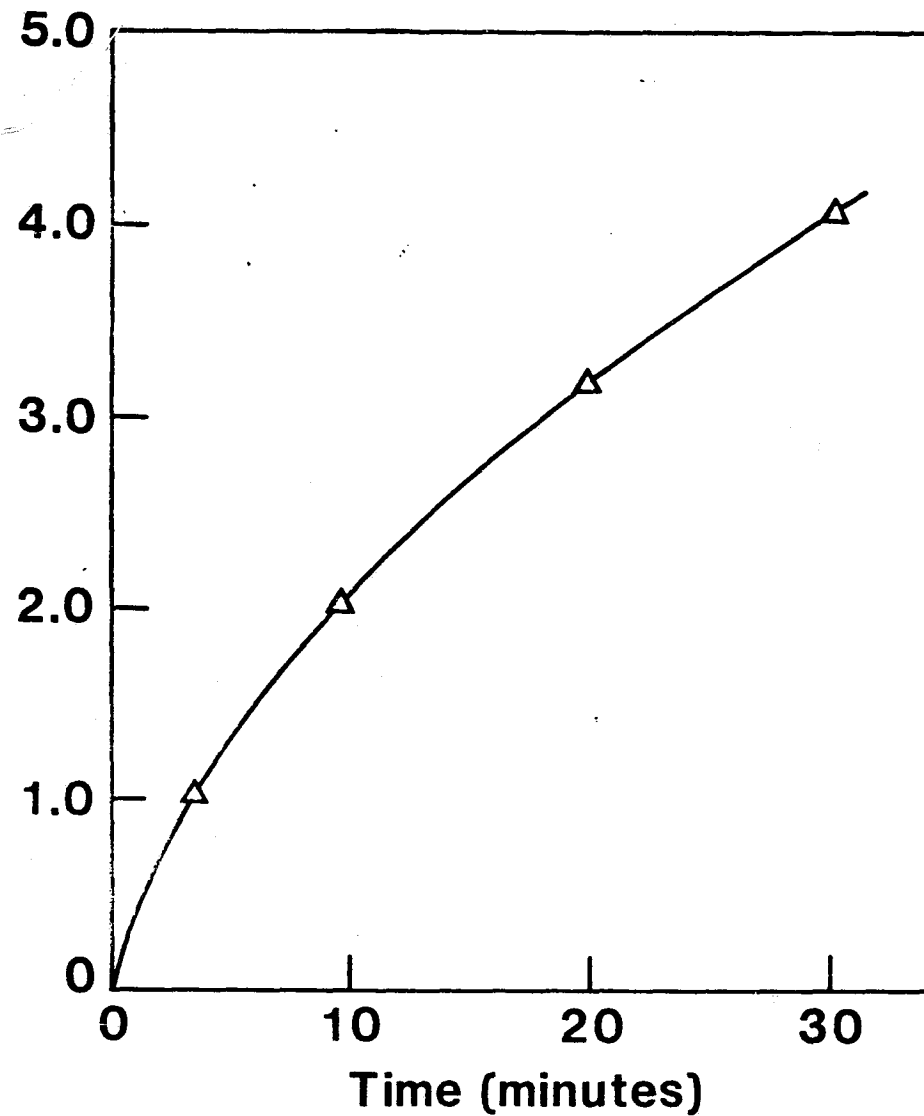

67

Chemical Vapor Deposition Apparatus

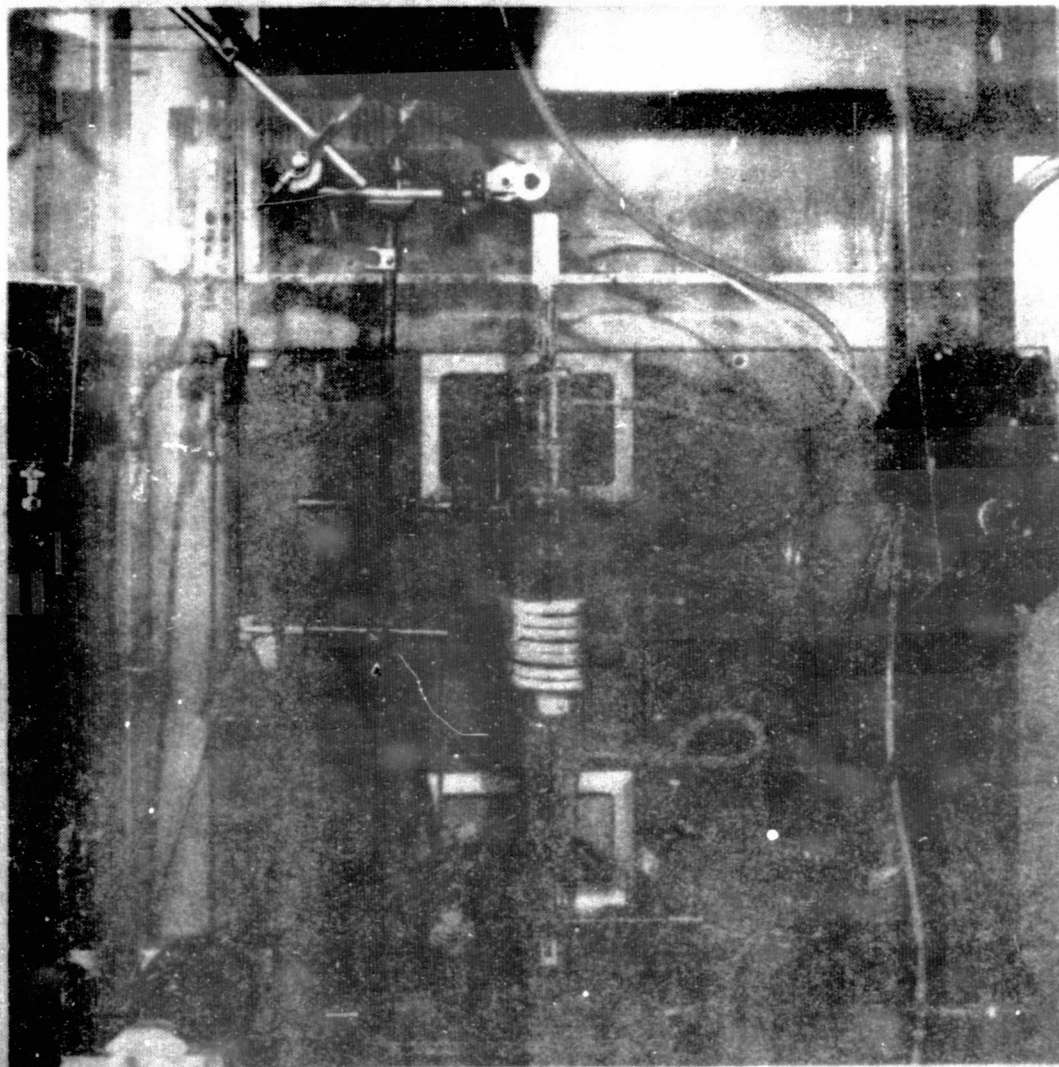

68

ORIGINAL PAGE IS
OF POOR QUALITY

BORON CARBIDE AND SILICON CARBIDE
COATED GRAPHITE FIBERS

RAYMOND J. SUPLINSKAS
AVCO SPECIALTY MATERIALS DIVISION

MARCH 23, 1978

- COATING MATERIALS:

SILICON CARBIDE

BORON CARBIDE

- SUBSTRATE

THORNEL 300

- COATING THICKNESS

0.1 MICRON

BULK ELECTRICAL PROPERTIES

● **RESISTIVITY**

SILICON CARBIDE ~ 100 Ohm-cm

BORON CARBIDE ~ 1 Ohm-cm

GRAPHITE ~ 10^{-3} Ohm-cm

● **SIC IS HI-TEMP. SEMICONDUCTOR**

BREAKDOWN VOLTAGE - 1100 VOLTS

(1/4" SPECIMEN)

- OTHER PROPERTIES

REFRACTORY

DIFFUSION BARRIER

ENHANCED WETTING

- OXIDIZED COATINGS

SiO_2 - INSULATOR

B_2O_3 - FUSIBLE

● CVD PROCESS



- RATE CONTROL VS. DIFFUSION CONTROL
- CVD PARAMETERS

TEMPERATURE

PLATING GAS COMPOSITION

FLOW GEOMETRY

RESIDENCE TIME

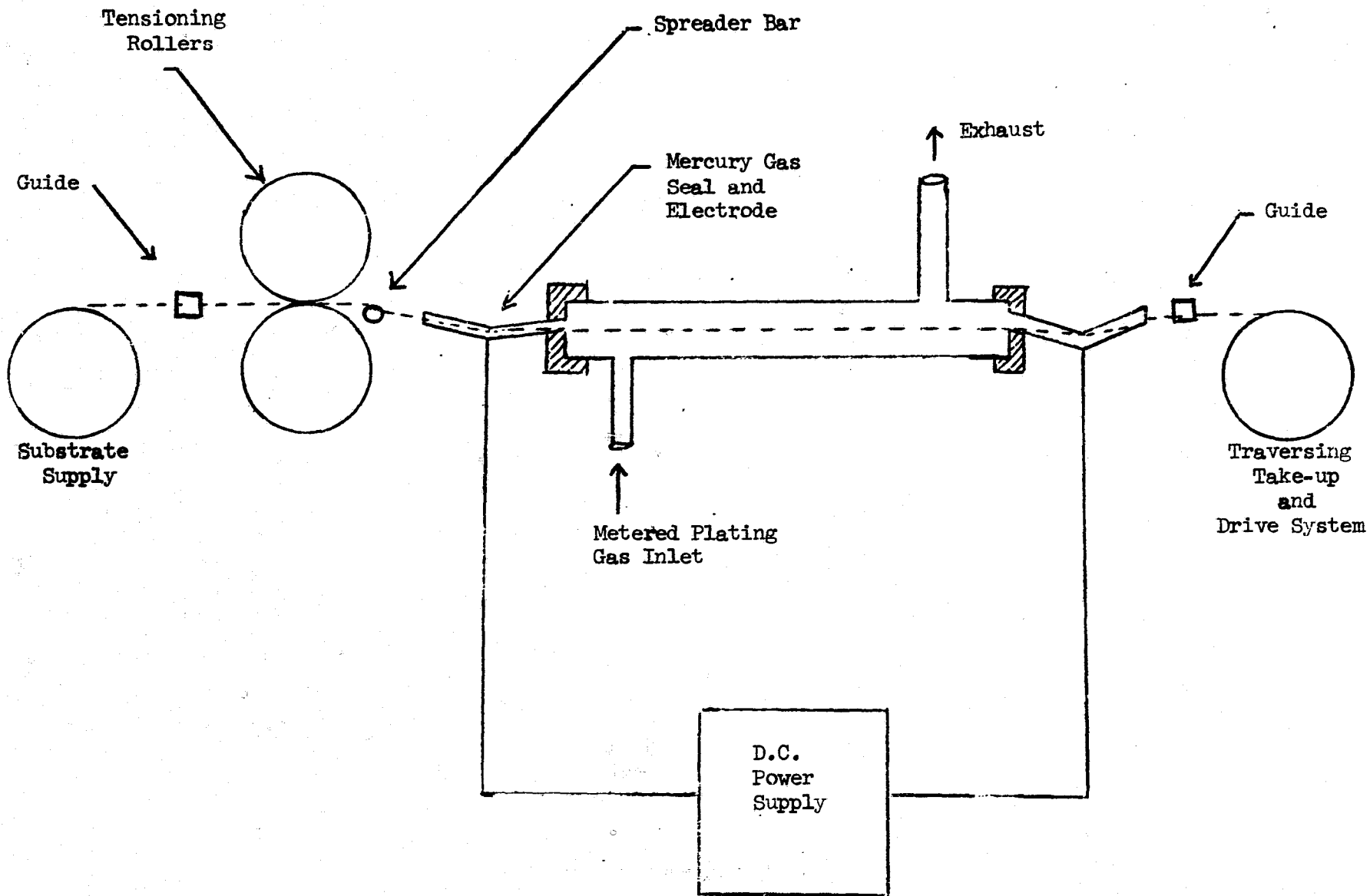

Figure 1. Sketch of CVD Reactor to Produce Carbide Coatings on Graphite

COATING CHARACTERIZATION

SEM

AUGER SPECTROSCOPY

TENSILE TESTS

BORON NITRIDE, SILICON CARBIDE
AND SILICONE COATED GRAPHITE FIBERS

HERBERT F. VOLK
UNION CARBIDE CORPORATION

MARCH 23, 1978

TECHNICAL TASKS

1. HIGH RESIDUE SILICON COATINGS.
2. BORON NITRIDE COATINGS.
3. SILICATE COATINGS.
4. SILICONE CARBIDE COATINGS.
5. BURN TEST CHAMBER.

NASA LANGLEY RESEARCH CENTER

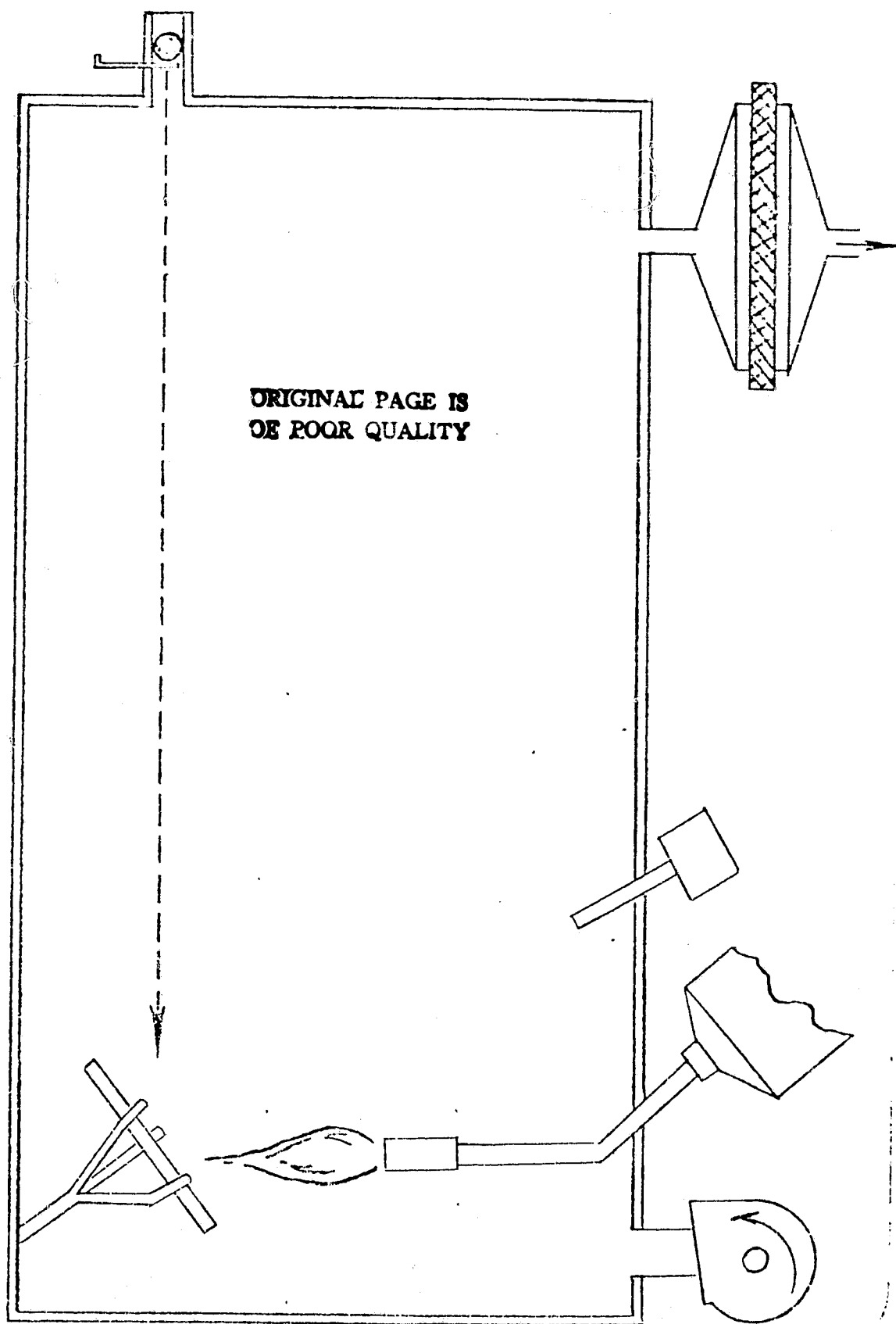

ORIGINAL PAGE IS
OF POOR QUALITY

REVIEW OF NASA-AMES MATERIALS

MODIFICATION PROGRAM

"AN APPROACH TO THE DEVELOPMENT OF FIRE
RESISTANT COMPOSITES"

JOHN A. PARKER

NASA AMES RESEARCH CENTER

MARCH 23, 1978

TYPICAL REACTION OF CHAR FORMING FOAMS DUE TO THERMAL LOADS

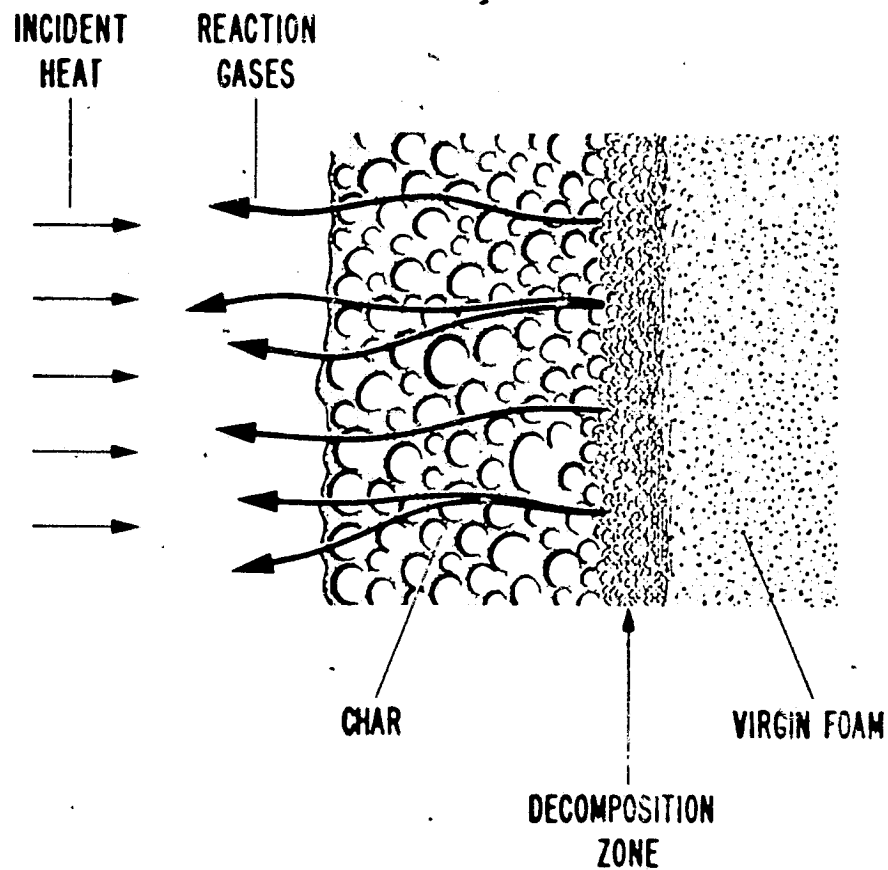

ORIGINAL PAGE IS
OF POOR QUALITY

CORRELATION OF PRIMARY THERMOCHEMICAL CHAR YIELD WITH MOLECULAR STRUCTURE

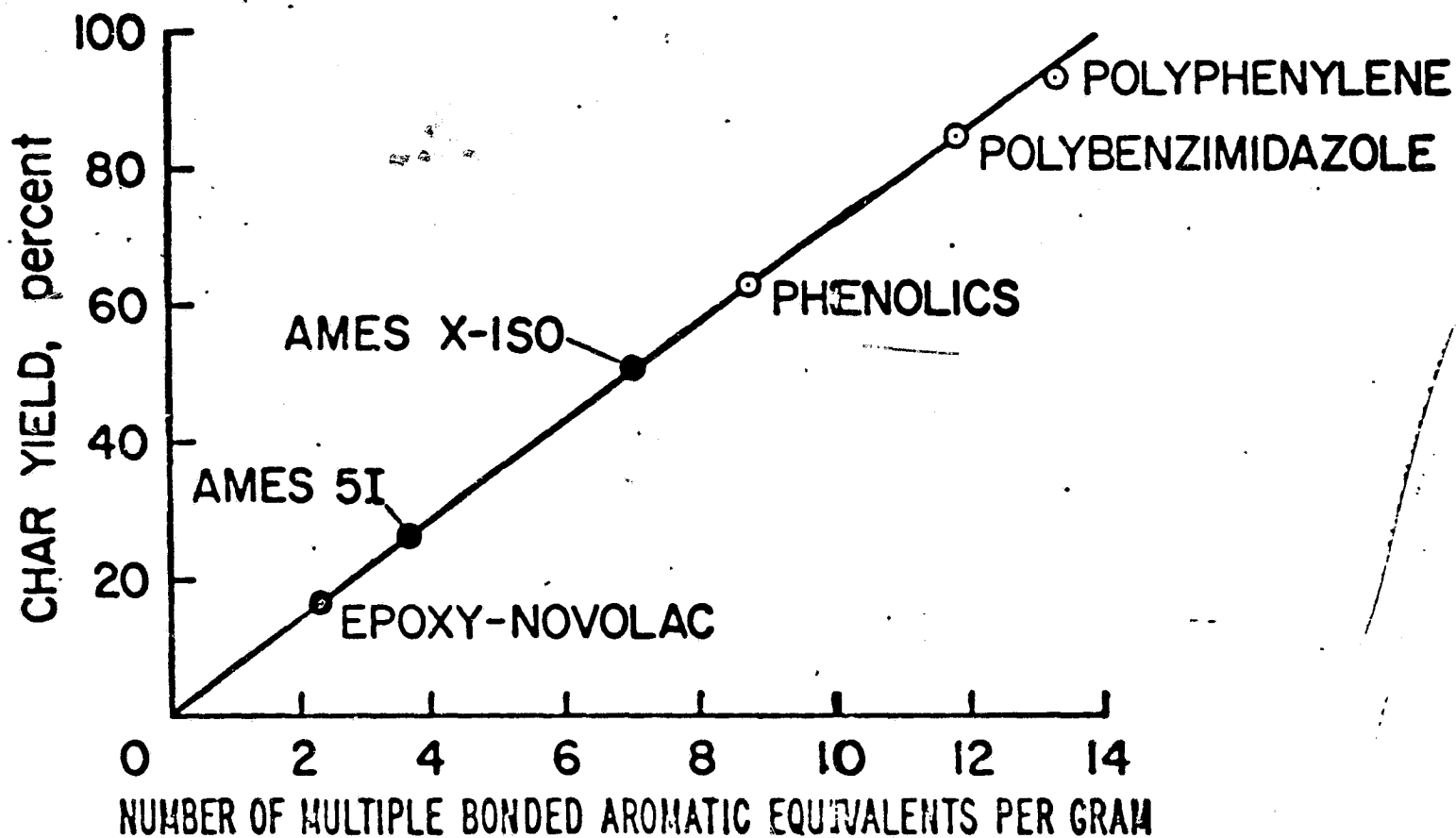

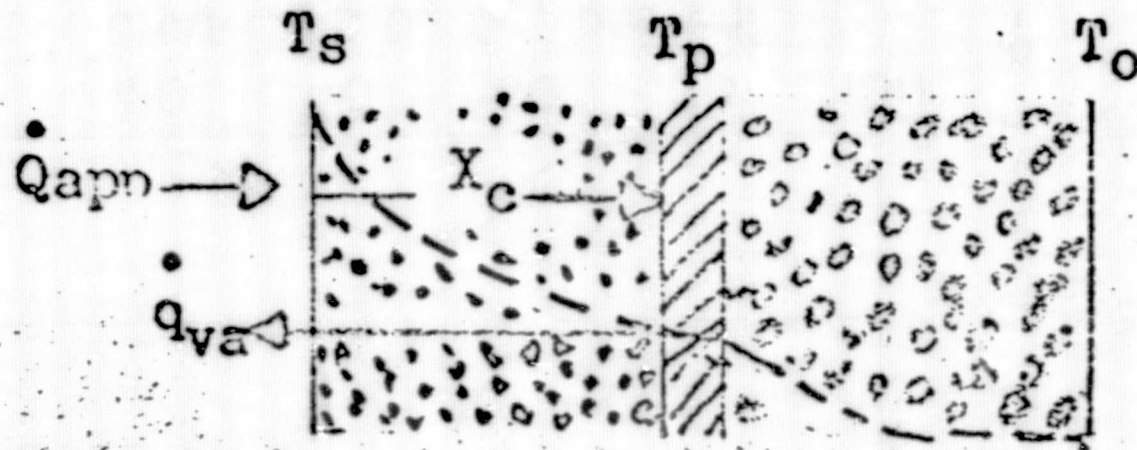

$$Y_c :: \int_0^t \dot{X}_c dt :: \int_0^t Q_{app} dt$$

$$\dot{X}_c :: \frac{1}{Q_{va}}$$

$$Y_c :: \frac{1}{Q_{va}} \Big|_t$$

ORIGINAL PAGE IS
OF POOR QUALITY

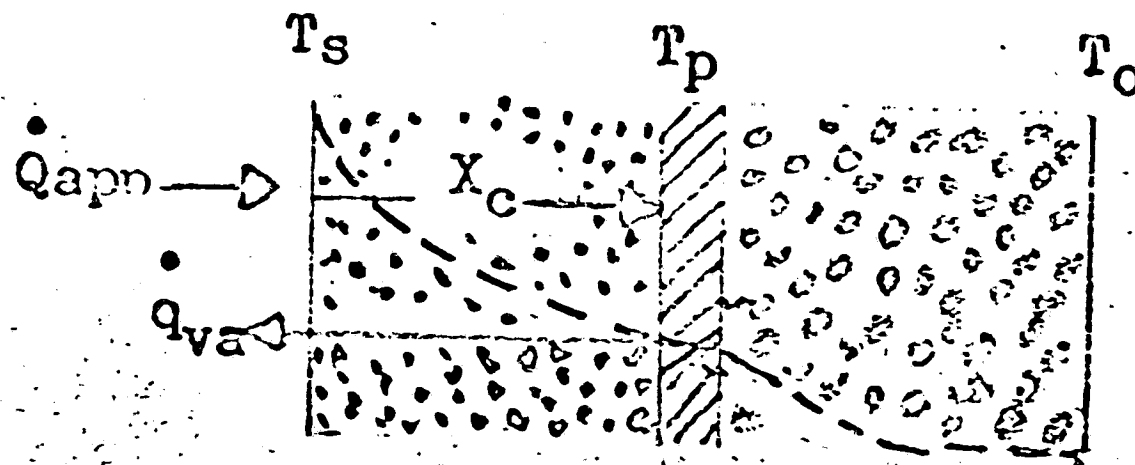

$$Y_c :: \int_0^t \dot{X}_c dt :: \int_0^t Q_{app} dt$$

$$\dot{X}_c :: \frac{1}{Q_{va}}$$

$$Y_c :: \frac{1}{Q_{va}} \Big|_t$$

ORIGINAL PAGE IS
OF POOR QUALITY

SUMMARY OF PROPERTIES OF CHAR FORMING FOAMED POLYMERS

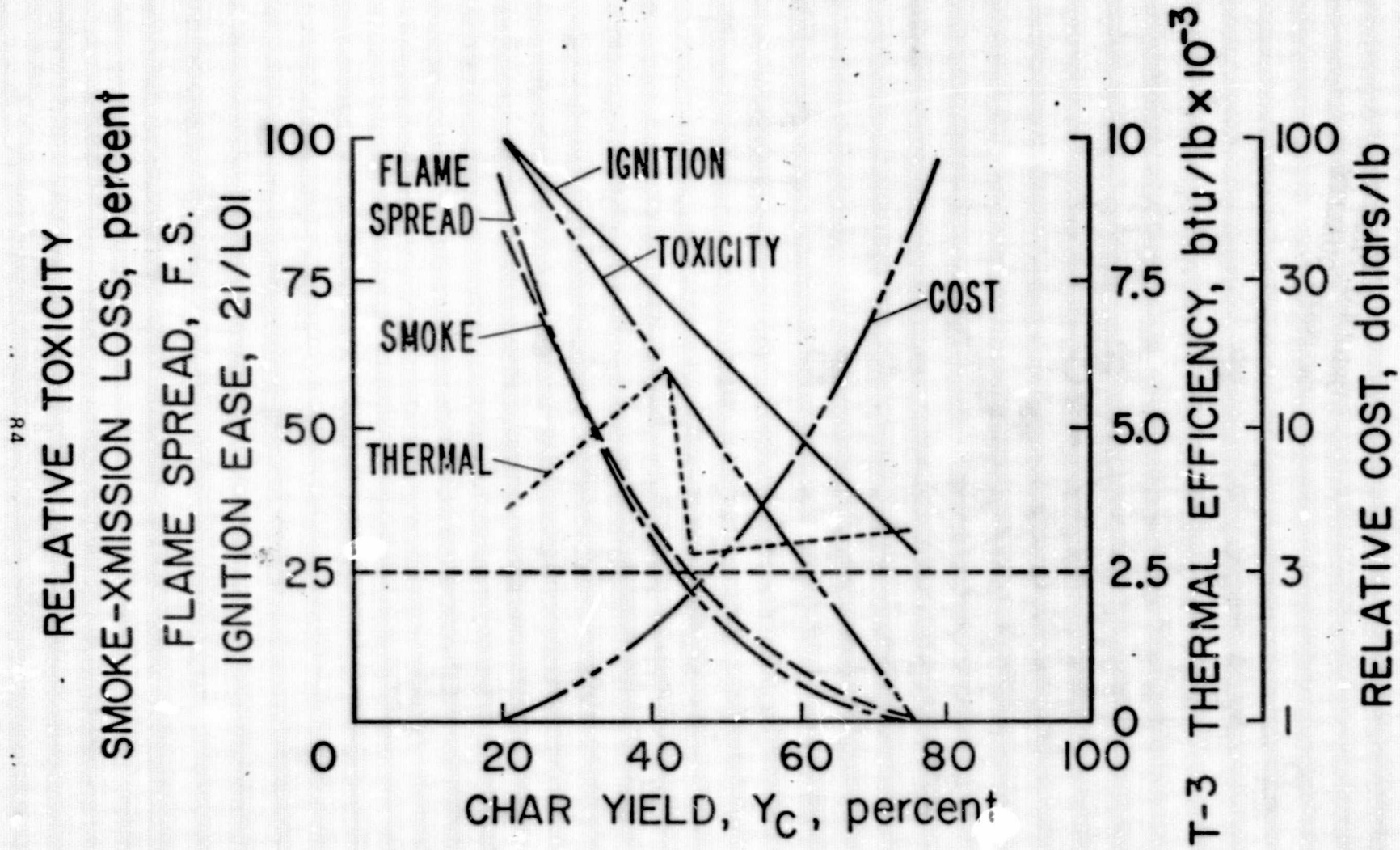

COMPOSITE CONFIGURATION OF AIRCRAFT INTERIOR PANELS

STATE-OF-THE-ART

- POLYVINYL FLUORIDE FILM, 0.0025 cm WITH POLYMETHYL METHACRYLATE ADHESIVE UNDERNEATH
- POLYVINYL FLUORIDE, 0.005 cm WITH DECORATIVE INK ON TOP
- TWO PLIES, TYPE 181, AND TYPE 120 E GLASS EPOXY PREPEG
- POLYAMIDE PAPER HONEYCOMB

ADVANCED

- PHENOLPHTHALEIN POLYCARBONATE FILM, 0.005 cm WITH DECORATIVE INK ON TOP AND CHLORENDIC ANHYDRIDE-EPOXY ADHESIVE UNDERNEATH
- ONE PLY TYPE 181 E GLASS BISMALIMIDE PREPEG
- POLYAMIDE ADHESIVE
- POLYQUINOXALINE FOAM IN POLYAMIDE HONEYCOMB

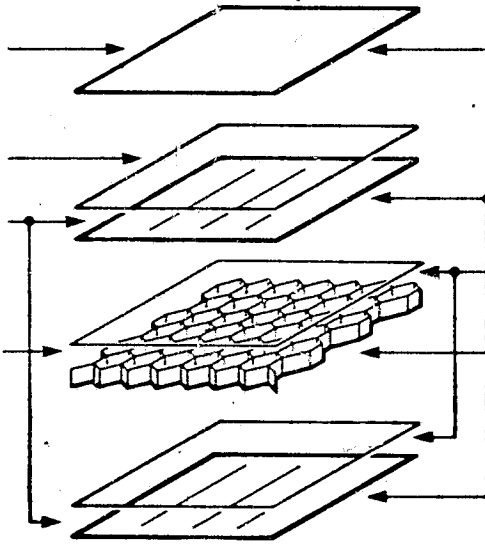

85

TOP VERTICAL

THERMAL DIFFUSIVITY

COMPOSITE TYPES:

- A. PVF, EPOXY-GLASS, POLYAMIDE-PHENOLIC PAPER HONEYCOMB, EPOXY-GLASS, 96 kg/m^3 (6 lb/ft^3)
- B. PBI-GLASS, PBI-GLASS TRUSS STRUCTURE, PBI-GLASS, 80 kg/m^3 (5 lb/ft^3)
- C. SAME AS B FILLED WITH PBI FOAM, 134 kg/m^3 (8.4 lb/ft^3)
- D. BISMALEIMIDE-GLASS, POLYAMIDE-PHENOLIC PAPER HONEYCOMB FILLED WITH POLYQUINOXALINE FOAM, BISMALEIMIDE-GLASS, 96 kg/m^3 (6 lb/ft^3)

ALL SAMPLES 2.5 cm (1 in) THICK

FRONT FACE HEAT FLUX $11 \times 10^4 \text{ W/m}^2$ ($10 \text{ Btu/ft}^2/\text{sec}$)

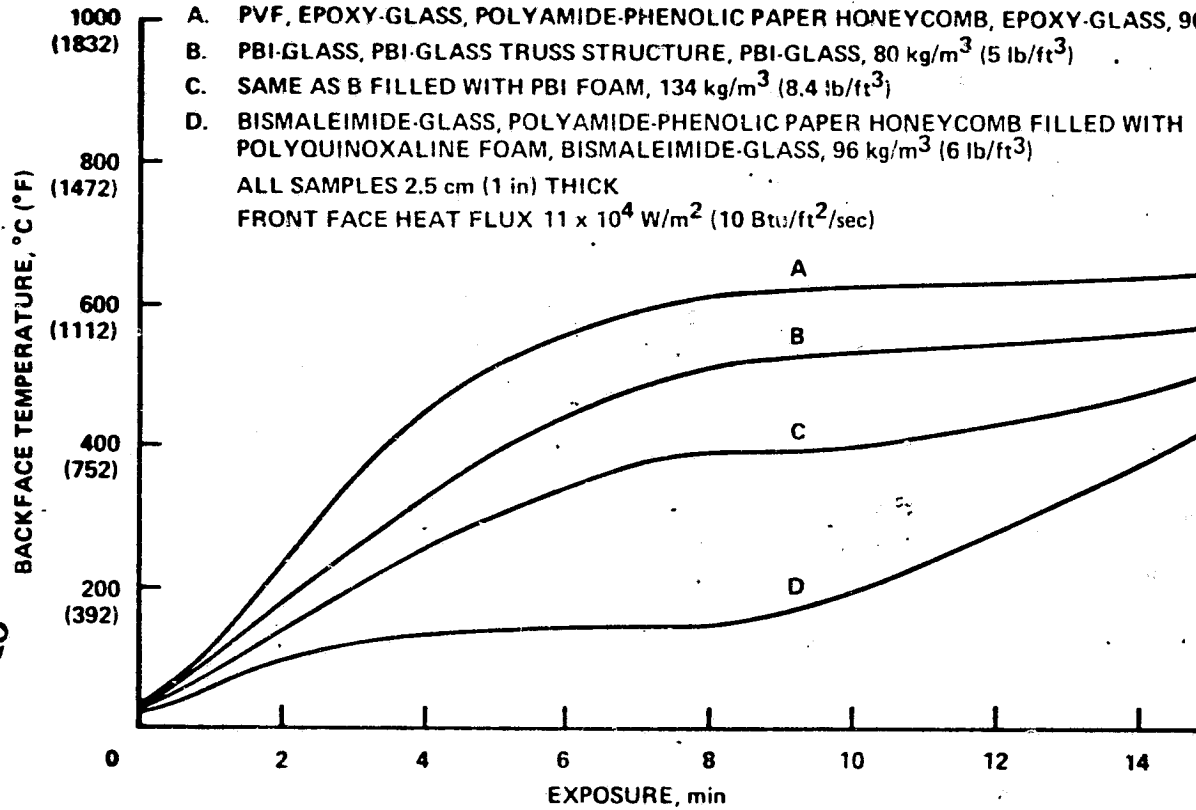

86

ORIGINAL PAGE IS
OF POOR QUALITY

TOP VERTICAL

**COMPARISON OF FLAMMABILITY PROPERTIES
OF AIRCRAFT INTERIOR PANELS**

<p>● COMPOSITE PROPERTIES</p> <p>DENSITY (ASTM D 71) FLATWISE TENSILE STRENGTH (ASTM C307), 24°C FIRE ENDURANCE, NASA AMES T-3 THERMAL TEST FACILITY, TIME (min) TO REACH BACK- FACE TEMPERATURE OF 204°C, FRONT FACE HEAT FLUX 11×10^4 W/m² SMOKE DENSITY (NBS), Ds 4 min. SPECIFIC OPTICAL DENSITY FAR 25.853, VERTICAL TEST METHOD STAND. 191, METHOD 5903</p>	<p>PVF, EPOXY-GLASS POLYAMIDE HONEYCOMB, EPOXY-GLASS</p> <p align="center">96 kg/m³ 0.02-0.05 N/m²</p> <p align="center">2</p> <p align="center">87</p> <p align="center">PASSES</p>	<p>PHENOL-POLYCARBONATE, BISMALIMIDE-GLASS, POLYAMIDE HONEYCOMB FILLED WITH POLYQUINOXALINE FOAM, BISMALIMIDE-GLASS</p> <p align="center">96 kg/m³ -</p> <p align="center">10</p> <p align="center">16</p> <p align="center">PASSES</p>
<p>● COMPONENT SMOKE DENSITY MAXIMUM SPECIFIC OPTICAL DENSITY (NBS SMOKE CHAMBER)</p>	<p>POLYVINYL FLUORIDE 7 POLYAMIDE PHENOLIC PAPER 2 EPOXY RESIN 90 GLASS -</p>	<p>PHENOL-POLYCARBONATE 5 NOMEX PHENOLIC PAPER 2 BISMALIMIDE RESIN 9 -</p>
<p>● COMPOSITE MATERIAL BALANCE % BY WEIGHT</p>	<p>POLYVINYL FLUORIDE 7.6 POLYAMIDE PHENOLIC PAPER 20.5 181, 120 GLASS 41.9 EPOXY RESIN 30.0</p>	<p>PHENOL POLYCARBONATE 5.0 POLYAMIDE PHENOLIC PAPER 20.5 181 GLASS 30.0 BISMALIMIDE RESIN 30.0 POLYQUINOXALINE 14.5</p>

87

**ORIGINAL PAGE IS
 OF POOR QUALITY**

TOP VERTICAL

STATUS OF NEW RESIN MATERIALS DEVELOPMENT

OBJECTIVE

To develop resins which provide enhanced fire resistance, and provide for minimal fiber release in graphite composites subjected to a fire and impact environment.

STATUS

1. High char yield resins with char yield (800°C, N₂) in excess of 50% such as phenolics and polyimides can, under post-crash fire simulation, almost totally eliminate conductive fiber release.
2. Currently available aromatic polymers such as phenolics and polyimides exhibit poorer fracture toughness than the currently used epoxy resins..
3. Currently used epoxy resins are also sensitive to photo-thermal oxidative degradation as well as weathering (humidity) resulting in a resin poor composite surface.

REDS

1. Development of new resins which provide both high char yield, fracture toughness and weathering resistance.
2. Development of hybrid composites and modified fibers.

STATUS OF NEW RESIN MATERIALS DEVELOPMENT

APPROACH

Advanced Resin Development and Modifications

- a. Polystyryl Pyridene (PSP) - SNPE (RFP issued)
- b. Bismaleimide - Technochemie (RFP issued)
- c. Phenolics - Resins obtained from Ciba-Geigy, Fiberite, Narmco
- d. Other Resins - Benzyl - Weyerhaeuser; Epoxy Copolymers - New York Polytechnic Institute; HR-600 - Hughes (being procured)

2. Curing Agents for Resins

- a. New curing agent to reduce voids and to provide optimum fracture-toughness characteristics in new resin-graphite composites

3. Hybrid Composites

- a. Use of metallic coatings to provide oxidation resistance and fire protection
- b. Use of intumescent coating to provide resistance to weathering and fire.

4. Fiber Modifications

- a. Reduce fiber conductivity by heating fibers in various atmospheres (NO etc)
- b. Evaluate other char forming mechanisms for resin-fiber combinations.

**PROGRAM OBJECTIVE: COMPOSITE PRIMARY AIRCRAFT
STRUCTURES**

SPECIFIC OBJECTIVE: COMPOSITE WING

**RTOP: EVALUATION AND DEVELOPMENT OF ADVANCED
STRUCTURAL COMPOSITE MATERIALS (743-02-11)**

OBJECTIVES: TO SELECT, PREPARE AND EVALUATE RESIN/GRAPHITE FORMULATIONS WHICH ARE MORE FIRE RESISTANT THAN CURRENTLY AVAILABLE STATE OF THE ART EPOXY/GRAPHITE COMPOSITES.

- TARGETS:**
- EVALUATE ADVANCED RESIN SYSTEMS INCLUDING EPOXIES, NOVOLAC PHENOLICS, POLYIMIDES, PSP AND BISMALIMIDE.
 - EVALUATE THERMAL PROTECTION COATINGS.
 - DETERMINE DEGRADATION OF MECHANICAL PROPERTIES UNDER THERMAL/FIRE LOAD IN STATE OF THE ART AND ADVANCED COMPOSITES.
 - CHARACTERIZE PRODUCTS OF THERMAL/FIRE DEGRADATION.

06

TOP VERTICAL

RESIN MATRICES FOR COMPOSITES

RESIN/CURING AGENT

TYPICAL CHEMICAL STRUCTURE

EPOXY RESIN BASED ON METHYLENE DIANILINE
 CURED WITH AROMATIC AMINE OR
 4,4' DIAMINO DIPHENYL SULPHONE (DDS)
 CIBA GEIGY MY 720; NARMCO 5208; FIBERITE 1034C

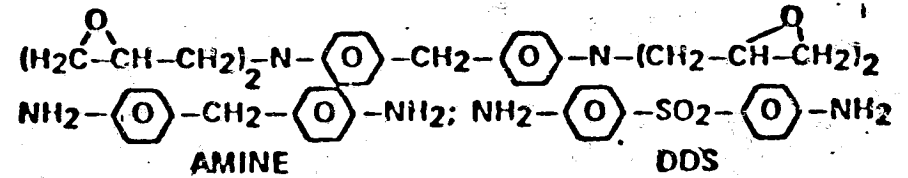

EPOXY RESIN BASED ON DIGLYCIDYL ETHER OF
 BISPHENOL A (DGEBA) OR 9,9-BIS
 (4-HYDROXYPHENYL) FLUORENE (DGEBF) OR
 COPOLYMERS CURED WITH TRIMETHOXYBOROXINE
 (TMB) OR MDA OR DDS

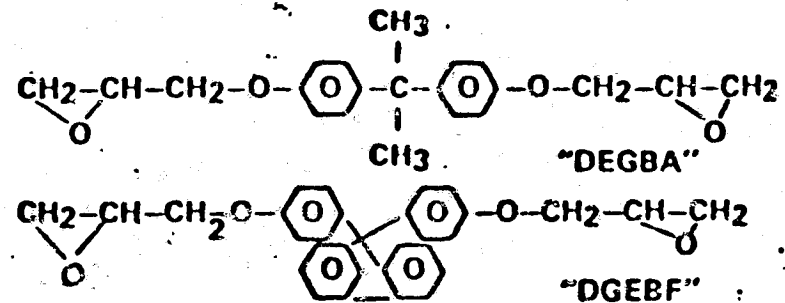

PHENOLIC NOVOLAC RESIN BASED ON
 CONDENSATION OF DIMETHOXY-P-XYLENE AND
 PHENOL CURED WITH HEXAMINE (XYLOK)
 CIBA GEIGY XYLOK 210

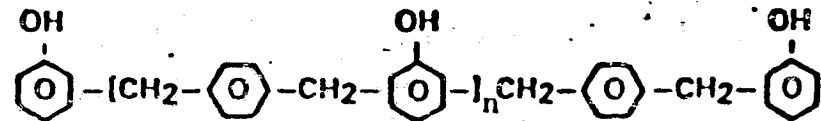

POLYBISMALEIMIDE PREPOLYMER
 (TECHNOCHEMIE M751)

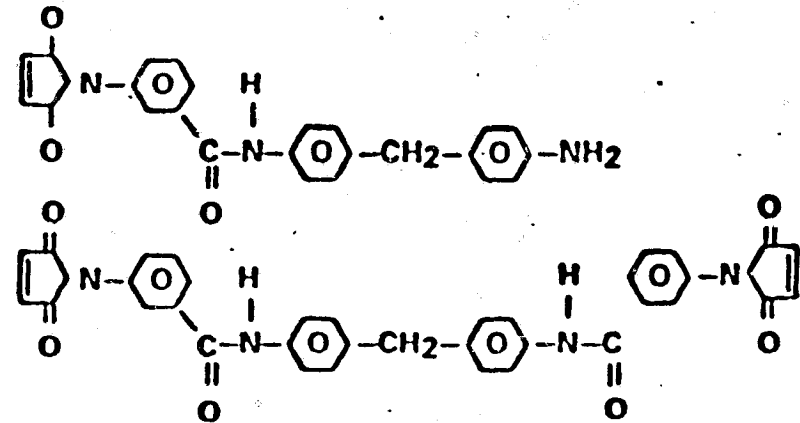

T6

ORIGINAL PAGE IS
 OF POOR QUALITY

RESIN MATRICES FOR GRAPHITE COMPOSITES

RESIN CURING AGENT

POLYSTYRYL PYRIDENE RESIN
(SNPE-PSP 6030)

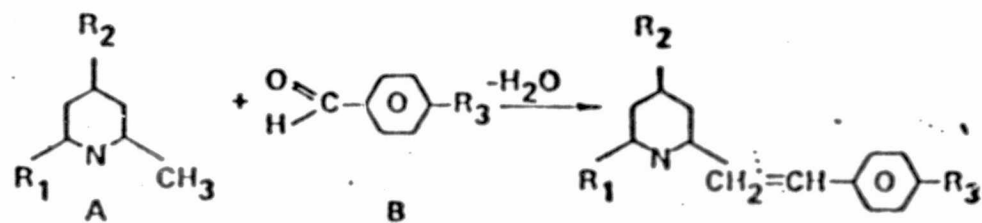

BIS(4-GLYCIDYL-2-METHOXYPHENYL) PHENYLPHOSPHONATE
EPOXY RESIN CURED WITH
N,N-DIETHYLAMINOPROPYLAMINE (DEAPA)
(HUGHES)

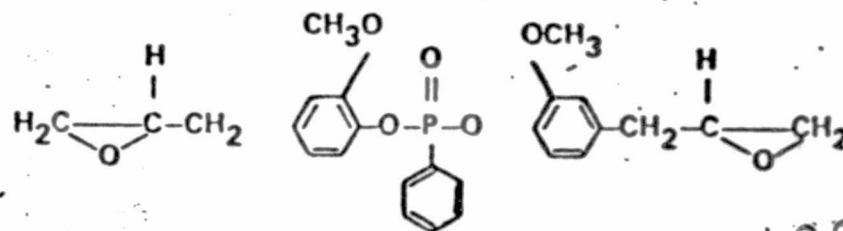

POLYMETHYLENE POLYPHENYLAMINE
(CIBA GEIGY NCNS-12M)

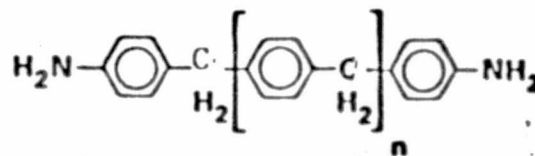

BENZYL RESIN (WEYERHAUSER)

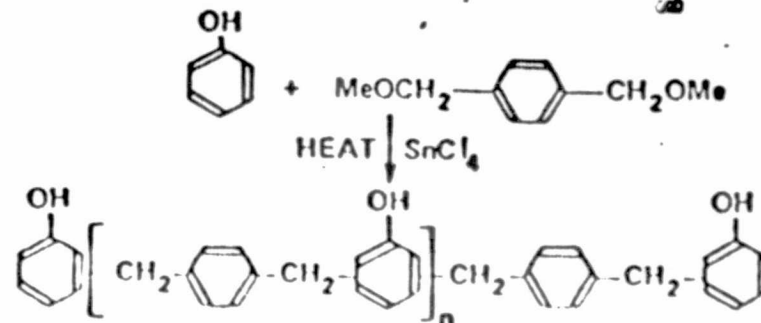

PRE POLYMER + 2n + 2MeOH

ORIGINAL PAGE IS
OF POOR QUALITY
ORIGINAL PAGE IS
OF POOR QUALITY

SIGNIFICANT THERMOCHEMICAL PROCESS CHARACTERISTICS OF DIFFERENT TYPES OF COMPOSITE MATRIX RESINS ON THE FIRE ENVIRONMENT

- A. THERMOCHEMICAL SCISSION (VAPOR PRODUCTION)**
 - 1. TEMPERATURE INDUCED CHAIN SCISSION**
 - a. RANDON CHAIN FRAGMENTATION**
 - b. SIDE CHAIN ELIMINATION**
 - c. RADICAL UNZIPPING MONOMER PRODUCTION**
 - 2. THERMAL CROSS-LINKING PROCESSES (CHAR FORMATION)**
 - a. THERMALLY INDUCED BIFUNCTIONAL REACTIONS OF CHAIN BEARING CHEMICAL GROUPS.**
 - b. THERMAL CRACKING REACTIONS PRODUCING RADICAL SPECIES WHICH COMBINE TO FORM STABLE POLYCYCLIC AROMATIC MOEITIES.**
 - c. AROMATIZATION INCLUDING CYCLIZATION/ DEHYDROGENATION.**

96

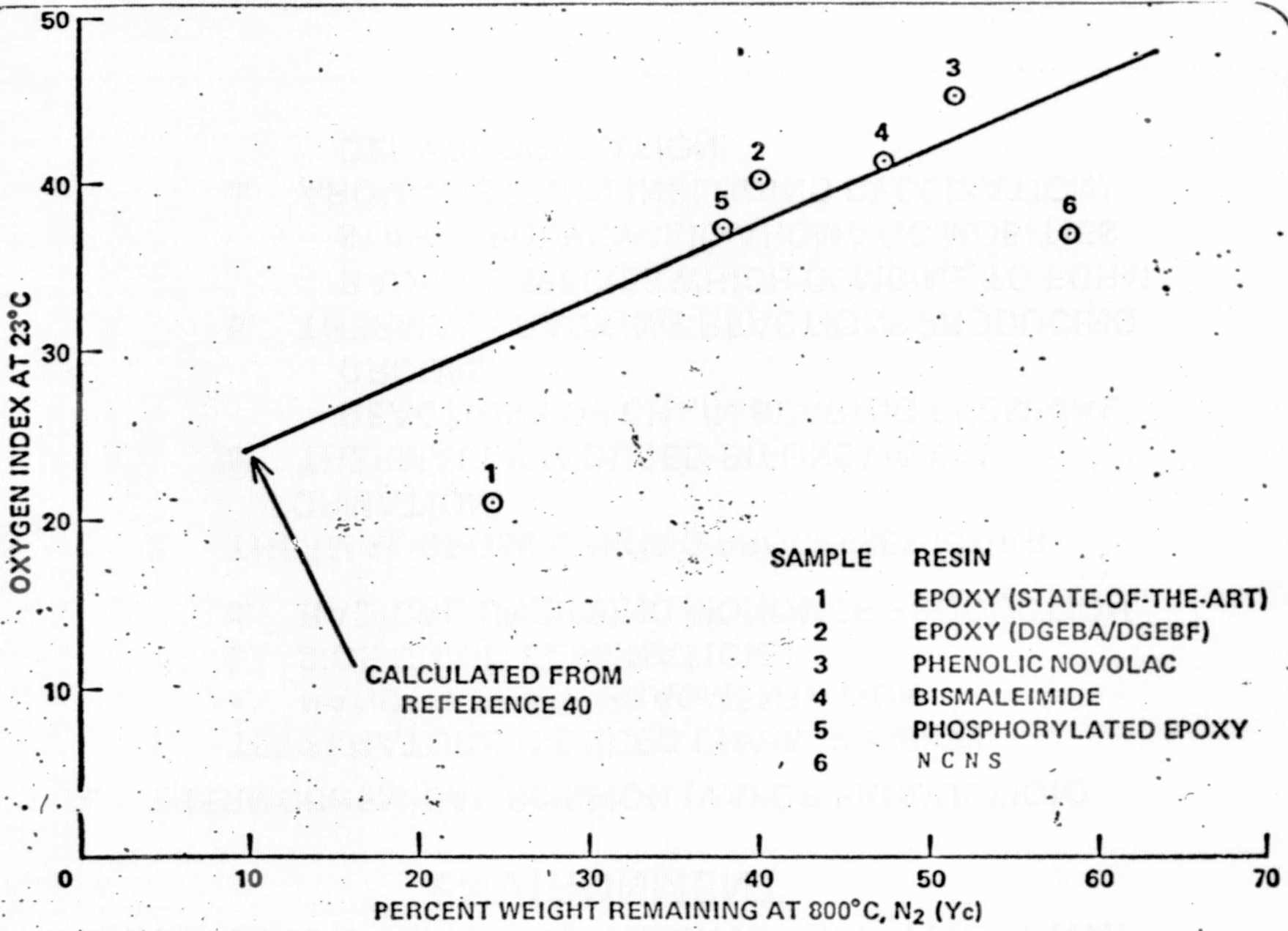
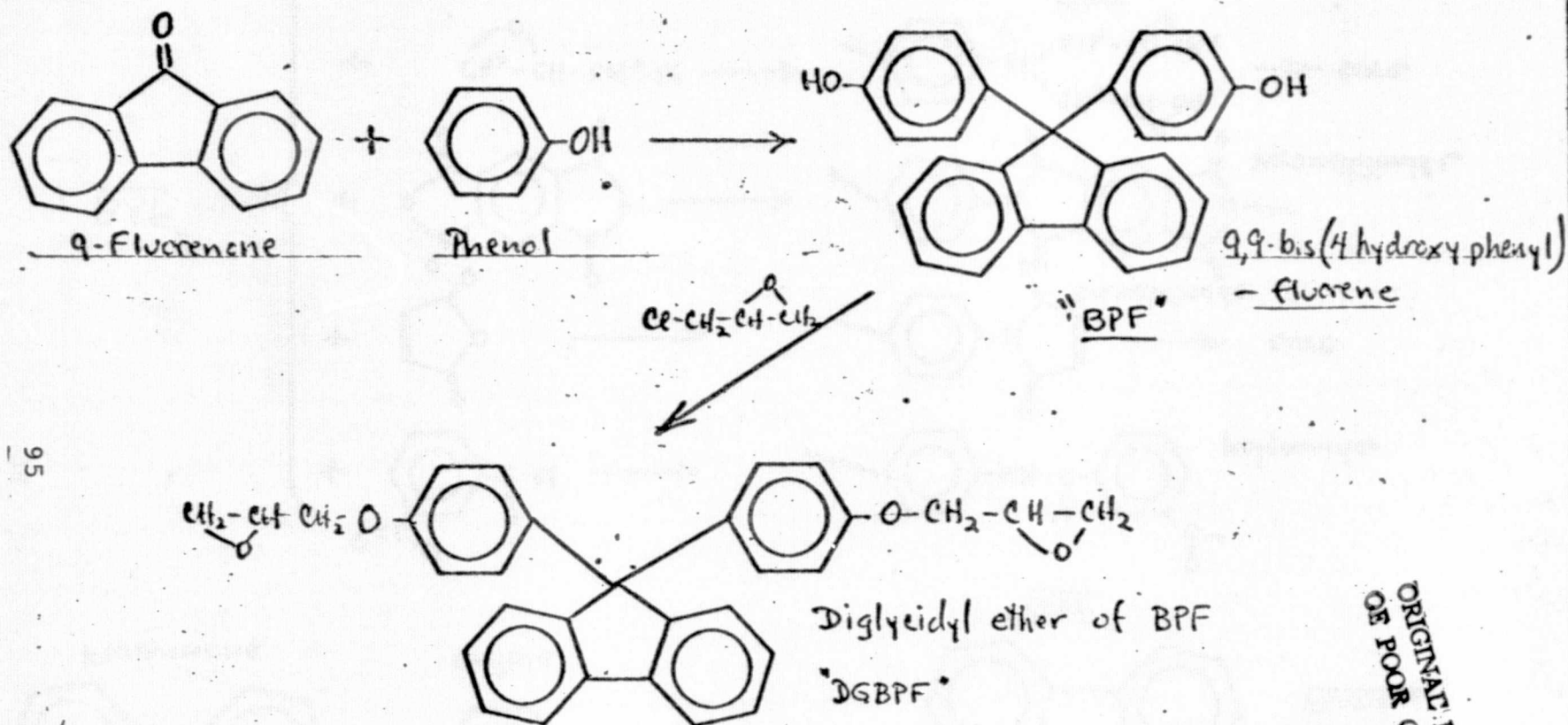

Figure 8 Effect of char yield of thermoset polymers on oxygen index.

TOP VERTICAL

CHEMISTRY OF NEW EPOXY RESINS



Cured with:

- Aromatic Anhydrides (e.g.: Pyromellitic Dianhydride)
- Aromatic Amines (e.g.: meta-Phenylene diamine, MDA)
- Catalytically: BF_3 , Trimethoxyboroxine

ORIGINAL PAGE IS
OF POOR QUALITY

POLYMERS FROM "BAF"

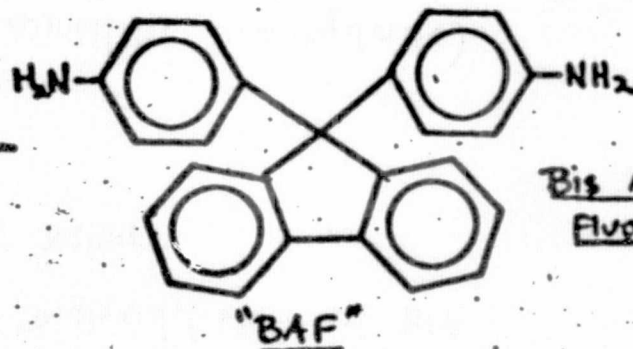
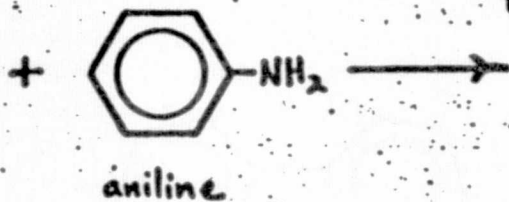
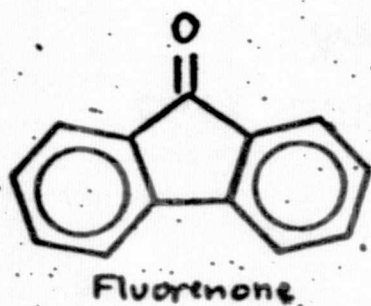

Bis Aminophenyl Fluorene

96

"BAF"

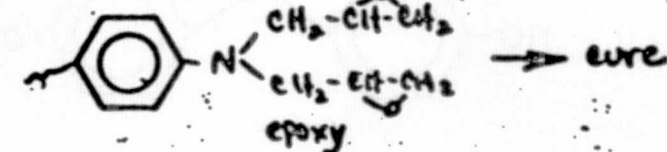
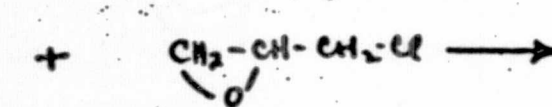
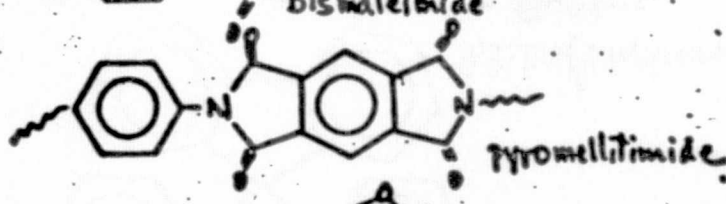
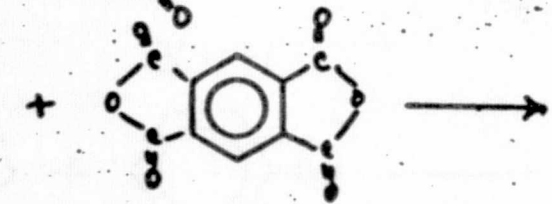
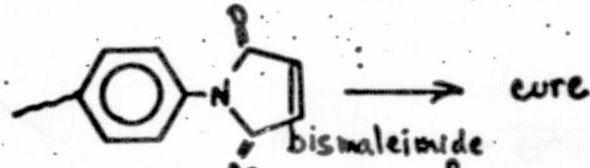
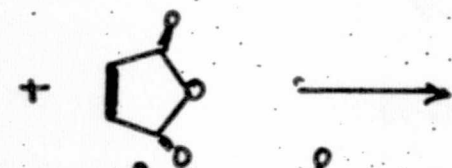
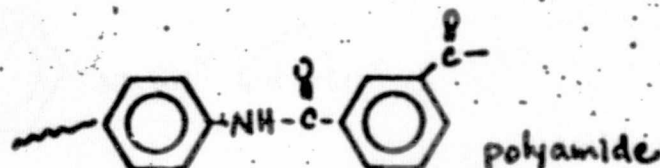
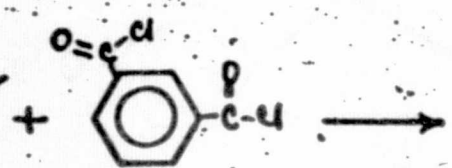

as curing agent for epoxy resins.

POLYSTYRYL PYRIDINE (PSP) POLYMER

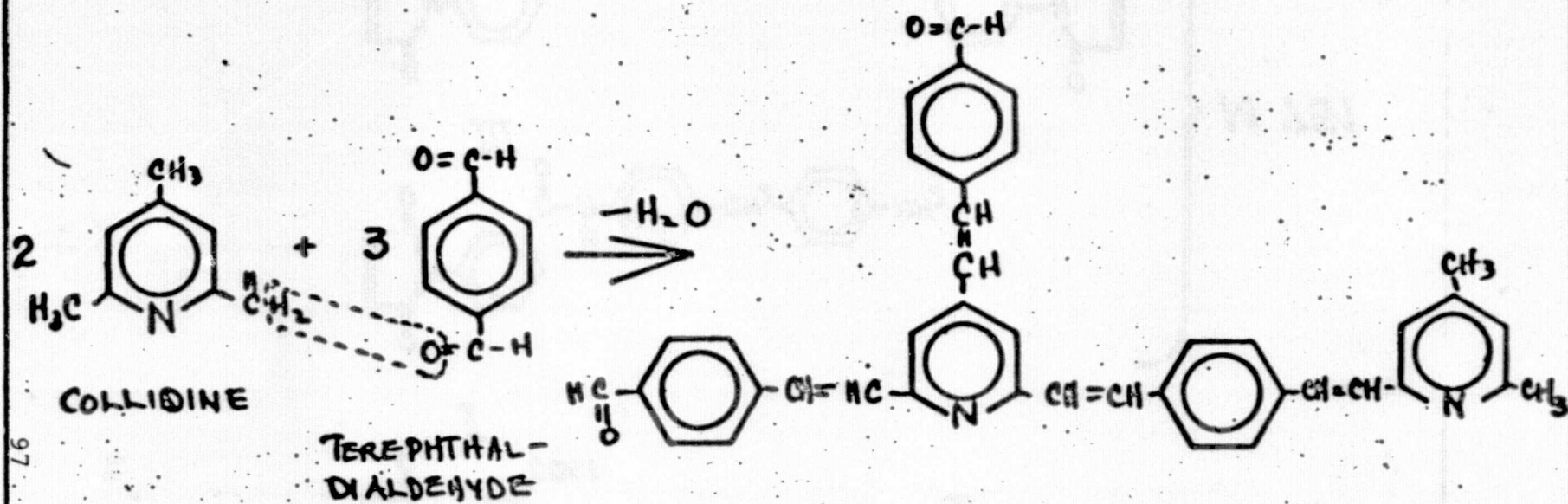

FURTHER CONDENSATION

GMP 177

CHEMISTRY OF EUTECTIC BISMALBIMIDE

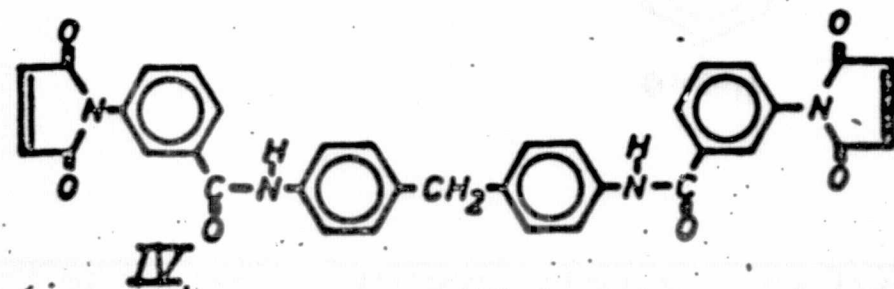
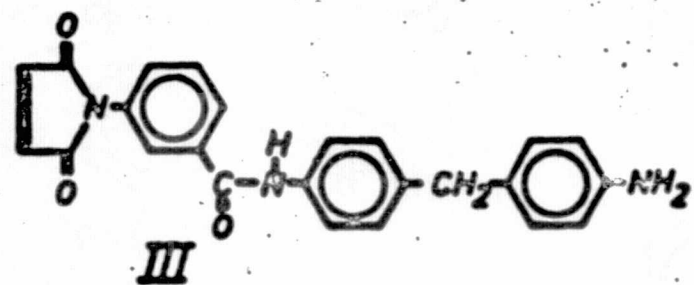
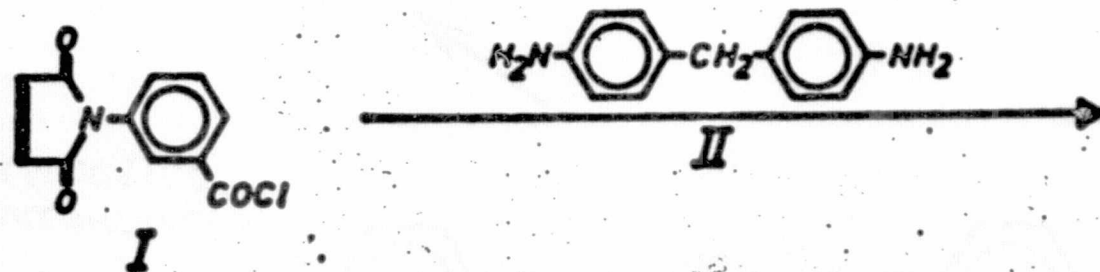
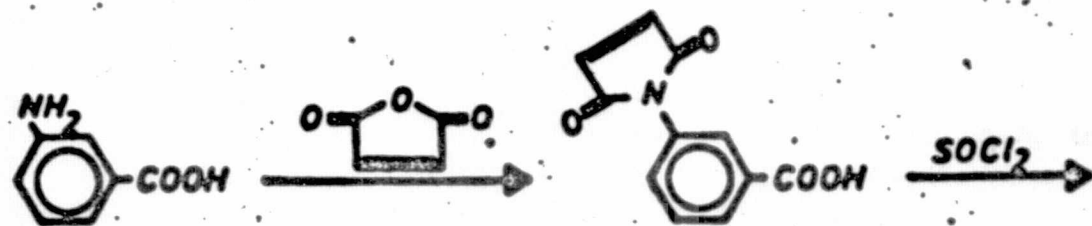

M 751

EFFECT OF MATRIX RESIN TYPE AND WEIGHT FRACTION ON THE STD. LIMITING OXYGEN INDEX OF GRAPHITE/RESIN COMPOSITES

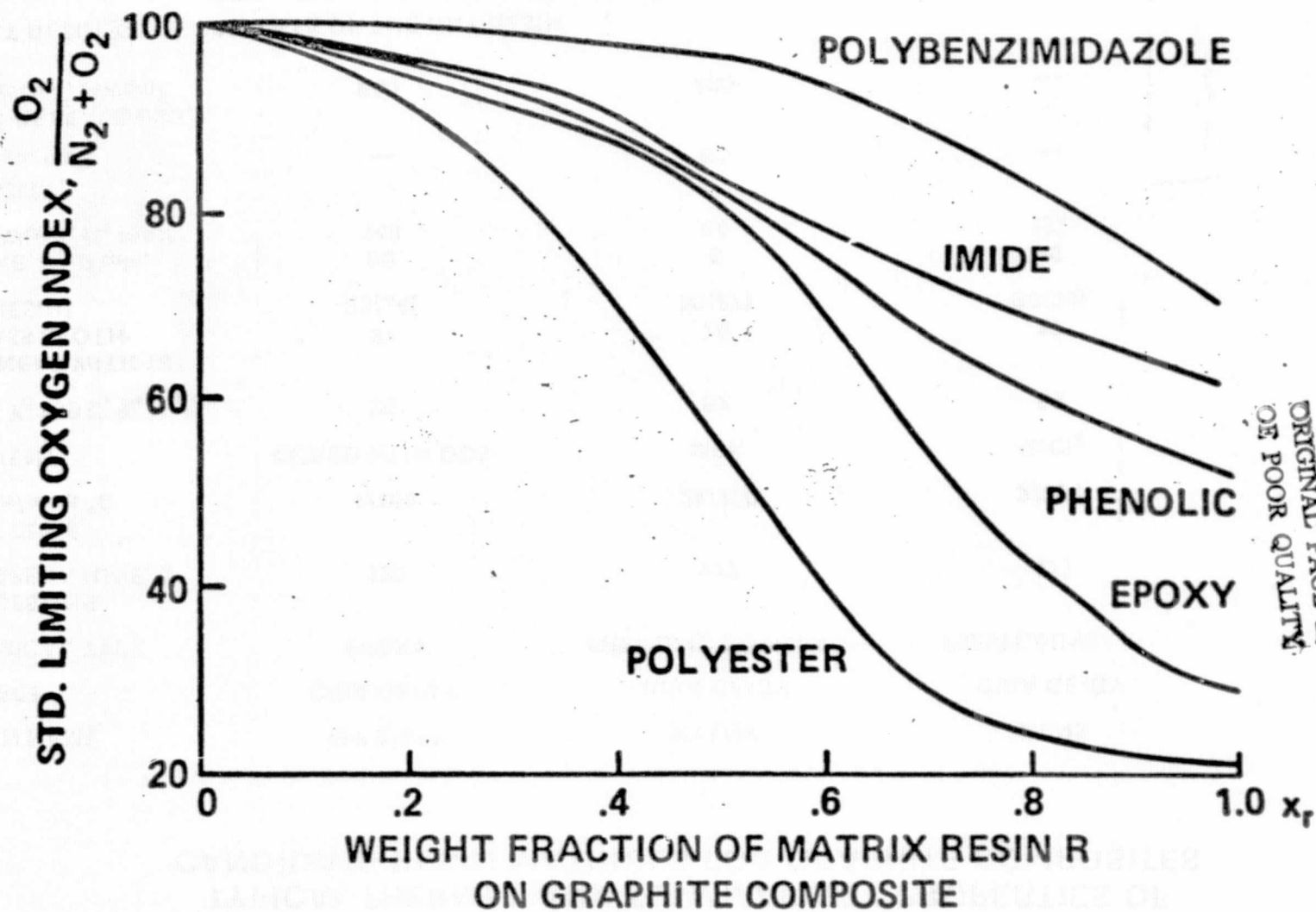



**TYPICAL THERMAL AND FLAMMABILITY PROPERTIES OF
CANDIDATE RESIN MATRICES FOR GRAPHITE COMPOSITES**

100

RESIN NAME	MY 720**	XYLOK	NCNS	FURAN
SOURCE	CIBA GEIGY	CIBA GEIGY	CIBA GEIGY	QUAKER
CHEMICAL TYPE	EPOXY	PHENOLIC NOVOLAC	PHENYLAMINE	FURAN
PROCESSING TEMPERATURE, C	120	177	177	135
POST CURE, hours/temp °C	4/180	24/250	2/224	2/135
SOLVENT	CURED WITH DDS	MEK	MeCl ₂	ACETONE
TGA, Y _c 850 C, %, N ₂ °	35	52	58	59
LOI, NEAT WITH 181 GLASS CLOTH (% RESIN)	21 23(34)	26 60(27)	27 90(29)	— 60(35)
SMOKE, D _s , 2 min. 2.5 W/cm ² , D _s MAX	80 140	6 44	89 172	0.8 75
TOXICITY, ALC ₅₀ , mg/l	—	61	—	—
HEAT RELEASE OSU, W-sec/cm ² , 5W/cm ²	500	460	—	—

*NEAT RESIN **STATE-OF-THE-ART RESIN
DDS: DIAMINODIPHENYL SULPHONE

EFFECT OF CHAR YIELD OF THERMOPLASTIC POLYMERS ON
OXYGEN INDEX

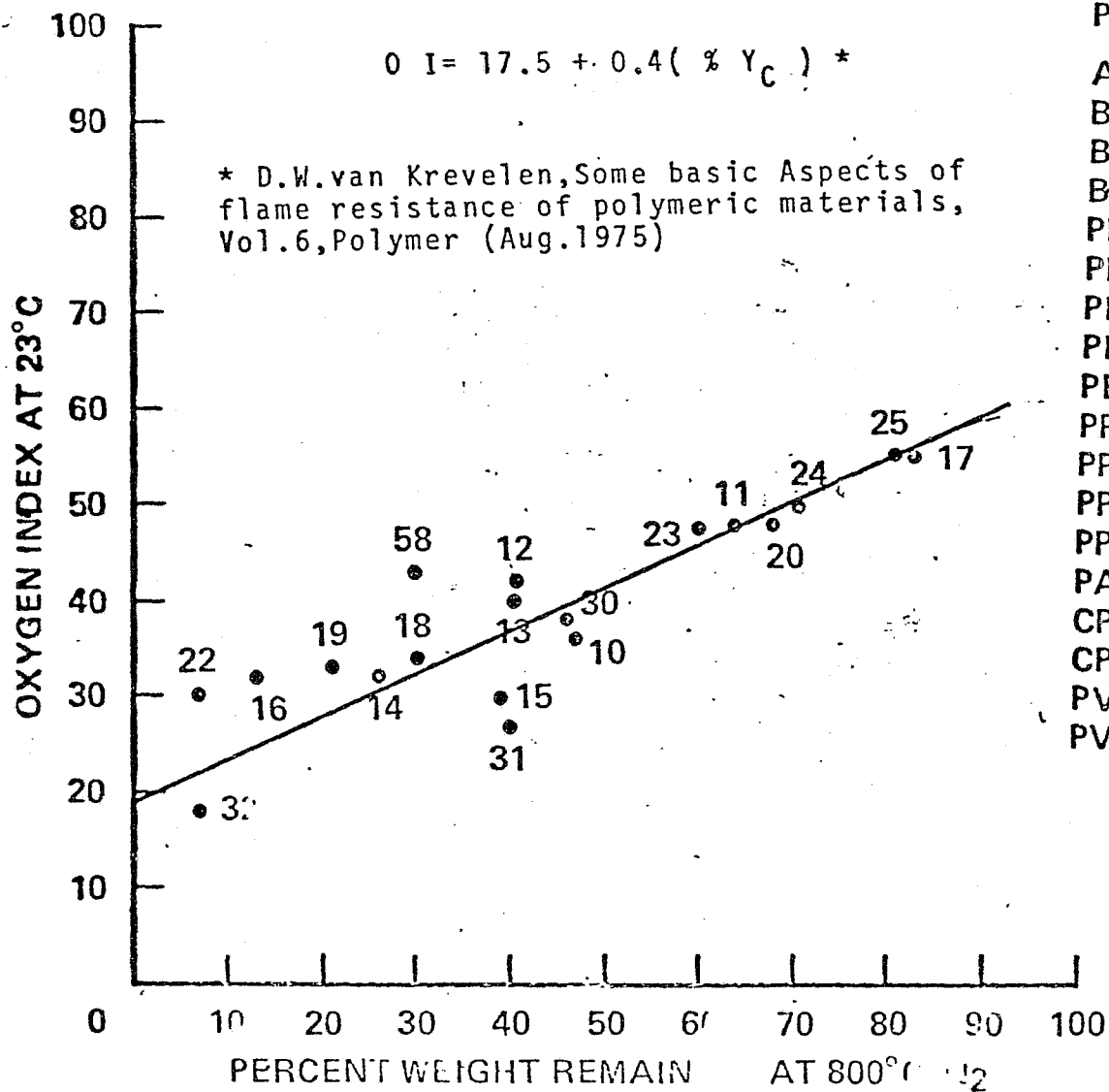

ORIGINAL PAGE IS
OF POOR QUALITY

TOP VERTICAL

TYPICAL THERMAL AND FLAMMABILITY PROPERTIES OF CANDIDATE RESIN MATRICES FOR GRAPHITE COMPOSITES

RESIN NAME	DGEBF/DGEBA**	BENZYL	K601	PSP 6030
SOURCE	POLYTECHNIC	WEYERHAUSER	RHODIA	SNPE/FRANCE
CHEMICAL TYPE	EPOXY	BENZYL	BISMALEIMIDE	POLYSTYRYL PYRIDINE
PROCESSING TEMPERATURE, C	135	150	182	250
POST CURE, hours/temp °C	3/135, 3/180	NONE	4/240	NONE
SOLVENT/CATALYST	TMB	WATER	NMP	NMP
TGA, % 850 C, N ₂ , %*	40	61	47	—
LOI, NEAT AND WITH 181 GLASS CLOTH (% RESIN)	38	34 90(32)	26 46(30)	36 100(27)
SMOKE, D _s , 2 min. 2.5 W/cm ² , D _s MAX	—	8 34	1 80	1 33
TOXICITY, ALC ₅₀ , mg/l	—	119	—	130
HEAT RELEASE OSU, W-sec/cm ² , 5W/cm ²	—	—	480	—

*NEAT RESIN

**50% mole of DGEBF

DGEBF: DIGLYCIDYL ETHER OF 9,9-BIS (4-HYDROXYPHENYL) FLUORENE

DGEBA: DIGLYCIDYL ETHER OF BISPHENOL A

TMB: TRIMETHOXYBOROXINE

NMP: N-METHYL PYROLIDONNE

"PRELIMINARY TEST RESULTS OF THE FIBER RELEASE
CHARACTERISTICS OF BASELINE GRAPHITE EPOXY COMPOSITES
COMPARED WITH NEW CHAR FORMING ANALOGS"

JOHN A. PARKER

NASA-AMES RESEARCH CENTER

MARCH 23, 1978

STATUS OF ENGINEERING AND TESTING OF COMPOSITE MATERIALS

OBJECTIVE

To develop test methods to adequately simulate Crash-Fire (or Fire-Crash) scenarios, to test baseline and modified graphite composite materials, and to determine cost benefit and risk analysis of baseline and modified systems.

STATUS

1. Laboratory type screening device developed and undergoing initial tests and modifications.
2. Larger scale thermal-mechanical test facility being designed based upon postulated limits of typical crash and fire scenarios.
3. Proposals sought for fabrication and testing of variant composite systems.
4. Proposal being studied for cost benefit analysis model, applicable to variant composite systems.

APPROACH

1. A screening type apparatus will be constructed based upon Charpy Impact testing machine and both direct burning and preheated composite samples. Expected data include: Breaking energy of baseline and degraded samples; weight loss and fiber release; Characteristics of broken sample, i.e., Critical fiber length, delamination and brittle resin failure; and residual strength of composite versus temperature.

2. Design and construction of larger scale test facility capable of variant: heat fluxes, bypass air flows, projectile impact, shock wave interactions, and fiber release classification due to fire, fire and impact, impact and fire, and fire and shock wave. Filtered output to provide for measurement of fiber release events.
3. Baseline and modified composite systems will be tested for mechanical properties, thermochemical properties, environmental properties, and response to thermal-mechanical shock.
4. Cost benefit and risk analysis models will be developed so that results of tests of modified composites may be used to determine cost benefit analysis of variant systems.

TOP VERTICAL

105

ORIGINAL PAGE IS
OF POOR QUALITY

ORIGINAL PAGE IS
OF POOR QUALITY

TOP VERTICAL

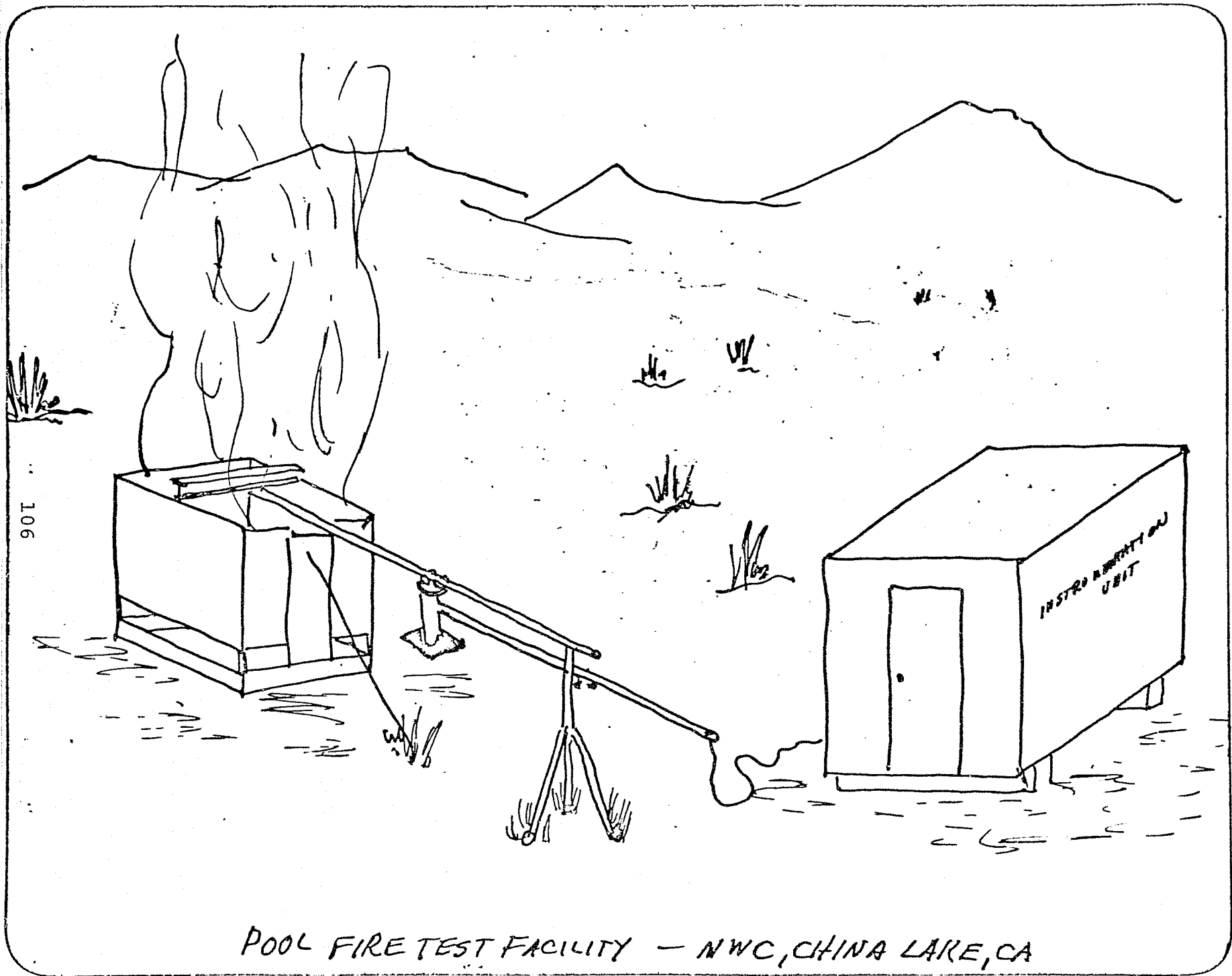

106

POOL FIRE TEST FACILITY - NWC, CHINA LAKE, CA

ORIGINAL PAGE IS
OF POOR QUALITY

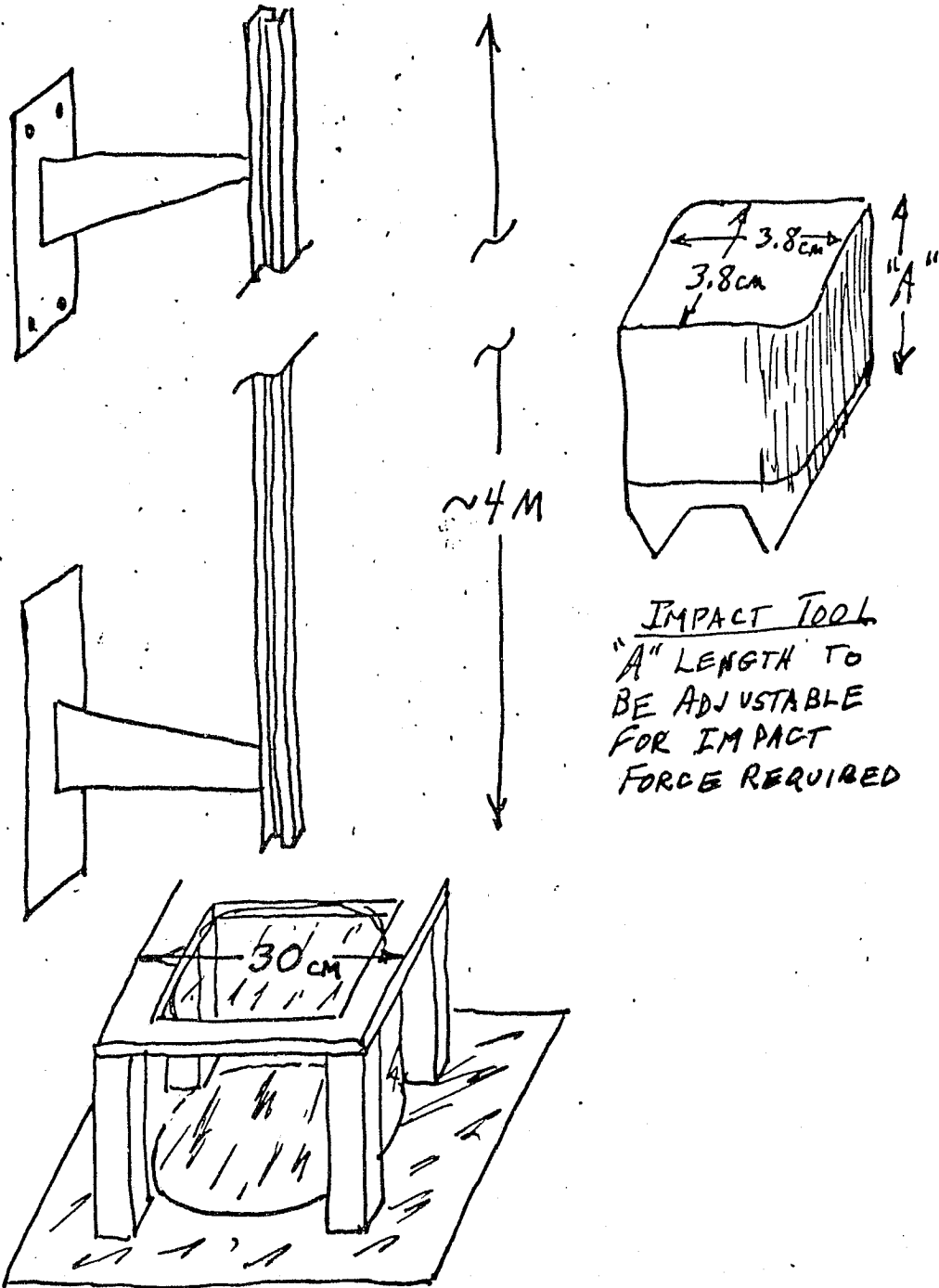

IMPACT TOOL
"A" LENGTH TO
BE ADJUSTABLE
FOR IMPACT
FORCE REQUIRED

DROP TESTING FIXTURE, CRPO, AMES RES. CTR.

NAME _____

FIBERGLASS CLOTH LAMINATES - SURFACE TEMPERATURE VS TIME

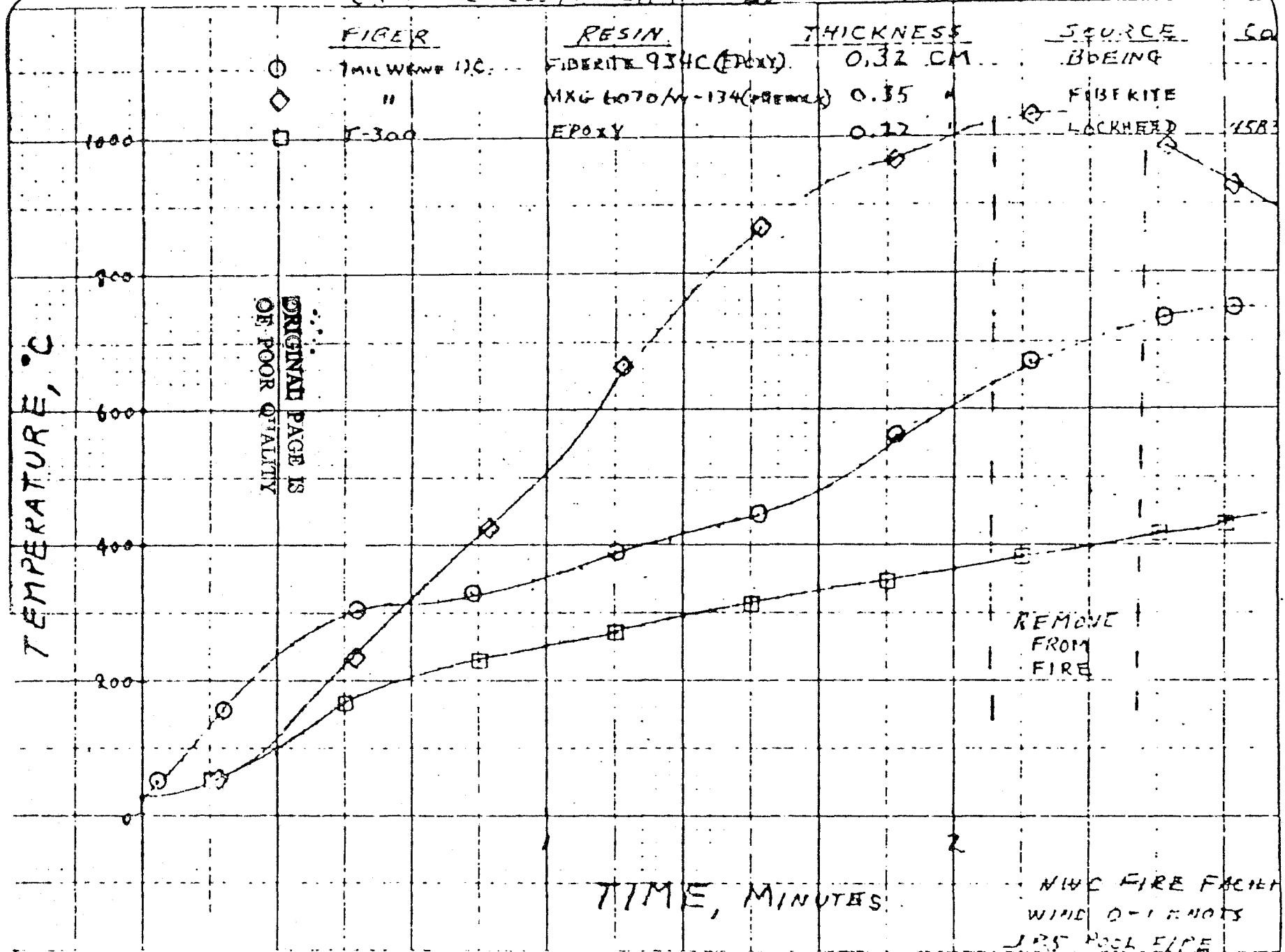

ORIGINAL PAGE IS OF POOR QUALITY

REMOVE FROM FIRE

NWC FIRE FACILITY
WIND 0-1 MPH
1.25' HOCL PIPE
(5' DIAMETER)

DEMONSTRATED TECHNOLOGY

CHINA LAKE/AMES TESTS

- 0 POOL FIRE TEST FACILITY/POST-BURN IMPACT
- 0 BASELINE AND 8 MODIFICATION CONCEPTS

MATERIAL

Gr/Ep

COATED Gr/Ep

GLASS FABRIC ON Gr/Ep

METAL COATED Gr/Ep

POLYIMIDE

GLASS FABRIC ON Gr/Ep

GLASS FILLED PMR

Gr/PHENOLIC

Gr/IMIDE (HR 600)

FIBER RELEASE

HIGH

MODERATE

MODERATE

HIGH

MODERATE

MODERATE

MODERATE

LOW

LOW

NSWC (DAHLGREN) TESTS

- 0 BURN + EXPLOSION TESTS SHOWED SIGNIFICANT FIBER RELEASE IN Gr/PHENOLIC

TOP VERTICAL

COMPOSITE FIRE

SIMULATION TESTING

I FIRES IN FLIGHT

A - EFFECTS OF AIR VELOCITY ON DETERIORATION OF BURNING OR BURNT MATERIALS

B - DETERIORATION DURING CRASH IMPACT OF BURNING OR BURNT MATERIALS

II FIRES ON GROUND

A - DETERIORATION IN POOL FIRE CONDITIONS

B - DETERIORATION OF BURNING MATERIALS UNDER IMPULSIVE LOADS

1 - LOW ORDER SHOCK WAVES; FUEL-AIR EXPLOSIONS; FUEL TANK RUPTURES, etc.

2 - LOW ORDER PENETRATIONS RESULTING FROM FUEL/AIR EXPLOSIONS, etc.

3 - HIGHER ORDER SHOCK WAVES & PENETRATIONS FROM HIGH VELOCITY DETONATIONS

TEST DEVICE DESIRED CAPABILITIES FOR MOST GENERAL USAGE.

AIR VELOCITY KNOTS	FIRE WATTS CM ²	SPECIFIC LOADING	IMPULSE Δ FORCE Δ TIME	PEAK PRESSURE (SHOCK) PSI	PROJECTILE VELOCITY M/SEC	PROJECTILE AREA	PROJECTILE SHAPE	DEBRIS CONTAINED	FACILITY LOCATION
10-300	8-15	YES	—	—	—	—	—	?	ARC NWC
0-30	8-15	YES	>100 KTS IMPACT	TBD	TBD	SMALL TO LARGE	BLUNT TO SHARP	YES	ARC
0-30	1-15	YES	—	—	—	—	—	YES	ARC
0-30	1-15		At ~ sec	UP TO 100	400	LARGE	BLUNT (SHOCK)	YES	ARC
0-30	1-15		At ~ ms to SECS	TBD	400	MED	BLUNT to SHARP	YES	ARC
0-30	1-15		At ~ ms	TBD	1000 to 3000	SMALL	SHARP	?	NWC
0-30	0-15	YES		150	0-500	VARY	VARY	YES	ARC

110

ORIGINAL PAGE IN
OF POOR QUALITY

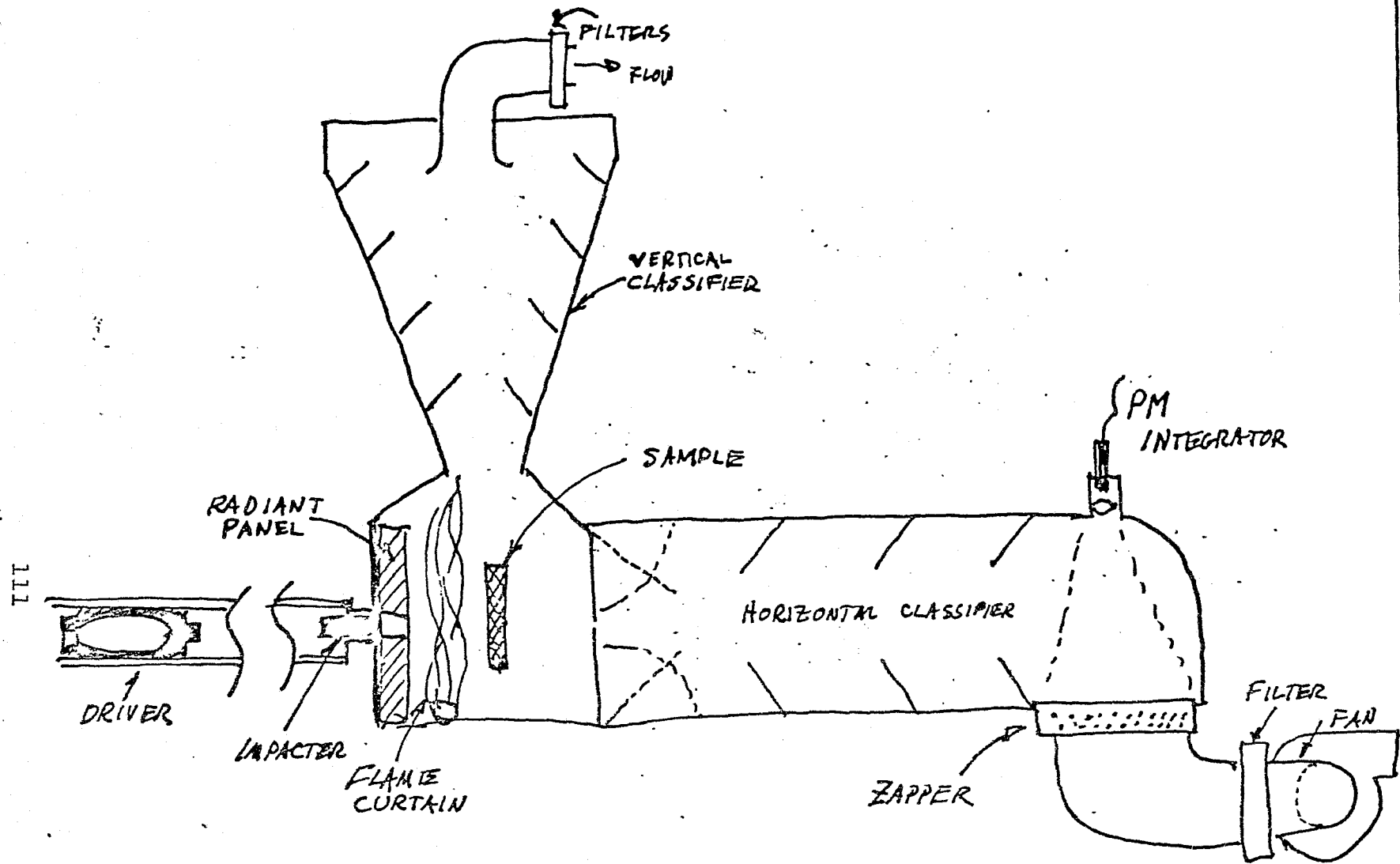

PROPOSED THERMAL-MECHANICAL SHOCK TEST FACILITY

FISH

ORIGINAL PAGE IS
OF POOR QUALITY

TOP VERTICAL

STATUS OF MATERIALS MODIFICATION
PROGRAM IN THE CHEMICAL RESEARCH PROJECTS OFFICE

Ames Research Center - Feb. 24, 1978

- I. Most probable conclusions (current opinion) concerning the fiber release threat from involvement of graphite epoxy resin systems in accidental commercial aircraft fires:

POSITIVE RESULTS

- a. The fire dynamics and thermal-mechanical impact sequencing used to make initial threat assessment relative to (I) are probably invalid. The fire chemistry, impact energy and sequence is probably not related to real postcrash commercial aircraft fires.
- b. Graphite structural composites with exceptional fire resistance and integrity may only be required in certain highly crash fire vulnerable areas of domestic aircraft.
- c. High char yield resin binders (matrix resins) with anaerobic char yields of greater than 60% when used in structural graphite composites can completely accommodate the normal aircraft crash fire without loss of fibers and can also provide long time retention of structural integrity in in-flight fires.
- d. Minor modifications of currently available graphite fiber systems may provide reduction of fiber conductivity to a degree that when combined with char forming resin systems may significantly reduce the threat without compromising mechanical properties.

STATUS OF MATERIALS MODIFICATION PROGRAM

Problematic Conclusions and Areas Requiring Intensive Effort

- a. Graphite epoxy structural composites may have an additional fiber release problem due to combined thermal and photo-oxidation environmental effect. Various coatings may resolve this in the short term.
- b. The use of high char yield resin systems may create minor processing and cost problems. Significant improvements in fracture toughness and impact strengths will have to be made before these resins can be safely used in structural applications.
- c. The fiber release problem is primarily a polymer flammability and mechanical stability problem.
- d. The effect of risk assessment on overall cost benefits for using graphite composites is confused by the lack of significant connection among crash fire scenario, crash-impact fire dynamics, crash fire fiber release and test simulation.

STATUS OF CONTRACT AND INTERFACE DEVELOPMENT WITH
INDUSTRY AND UNIVERSITY ELEMENTS - Feb. 24, 1978

I. INDUSTRIAL INTERFACE

A. Materials and Process

I. Resins

- a. Hughes Aerospace Group, Culver city, CA (Dr. N. Bilow) High char yield, void free composites from HR-600 polyimides cured with 1,2 poly addition acetylenic termination. Briefing conducted. Obtained and tested composite samples.
(Proposal being submitted)
- b. Hitco, Gardena, CA (Dr. George Lee) Prepreg and composite fabrication from new phenolic and benzyl resin systems. Supplied state-of-the-art test specimens. Investigation of high temperature interface coatings.
(Proposal being submitted)
- c. Composites Horizons, Ontario, CA (Dr. Ira Petker) Processability and initial physical properties screening on new experimental resins - i.e., hot melt bismaleimide, epoxy resin systems based on fluorenone bisphenol derivatives and others (Proposal being submitted)
- d. Technochemie GMBH, Heidelberg, West Germany (Dr. H. Stenzenberger) Development of graphite - bismaleimide prepregs and composites based on hot melt

bismaleimide resins. (Contract being negotiated)

- e. SNPE, Paris, France (Dr. B. Melassine) Development of polystyryl pyridane resin (PSP 6030) for application to graphite composites

(Contract being negotiated)

2. Fibers

- a. Union Carbide, Parma, Ohio (Dr. B. H. Eckstein) Application of carbon fiber coatings with increased resistivity without significantly affecting composite performance or fabrication cost. (Discussions being held for a proposal)
- b. Cellanese Research Division, Summit, New Jersey (Dr. J. Leal) Modification of graphite fibers by coating or "doping" with high resistance silica, glass, boron, metal carbides (Discussions for proposal; presentation to be made)

II. University Interface

University of Utah, Salt Lake City, Utah (Dr. A. Sosin) Study of the effects of optimum cure of resins on the thermochemical and flammability properties of epoxy and other advanced resins (Contract in final stages of negotiation).

Polytechnic Institute of New York, Brooklyn, New York (Dr. E. Pearce) Synthesis of modified epoxy resins and copolymers. (Grant proposal being discussed).

ENGINEERING TESTING AND MODELING

1. Econ, Inc., San Jose, California - Modeling and cost benefit analysis of various composites (Contract being negotiated)
2. Douglas Aircraft Company, Long Beach, California - Environmental testing of composite structures (Discussions only).
3. Lockheed Aircraft Company, Burbank, California - Aircraft fire testing of composite structures (Discussions only).
4. San Jose State University, San Jose, California - Design and computation of mechanical test devices for composites (Continuation of existing Grant).
5. University of California, Berkeley, California - Design and construction of crash fire test facility for graphite composites.

REVIEW OF NASA LEWIS
MATERIALS MODIFICATION PROGRAMS

117

TITO T. SERAFINI
NASA-LEWIS
3-23-78

NASA-LEWIS MATERIAL

MODIFICATION PROGRAM

OBJECTIVE:

TO DEVELOP COMPOSITE MATERIALS WHICH HAVE THE DESIRABLE HIGH PERFORMANCE PROPERTIES OF POLYMER MATRIX/GRAPHITE FIBER COMPOSITES WHILE ELIMINATING THE HAZARD TO UNPROTECTED ELECTRICAL EQUIPMENT CAUSED BY GRAPHITE FIBER RELEASE IN FIRE RELATED ACCIDENTS.

811

MAJOR THRUSTS:

- DEVELOPMENT OF NEW AND/OR IMPROVED MATRIX RESINS
- IDENTIFICATION OF ALTERNATE FIBER MATERIALS
- DEVELOPMENT OF HYBRID COMPOSITES WHICH EXHIBIT IMPROVED RETENTION OF CONSTITUENT MATERIALS WHEN SUBJECTED TO SEVERE OXIDATIVE CONDITIONS.

LERC

TITLE: SYNTHESIS OF IMPROVED PHENOLIC RESINS

OBJECTIVE : TO SYNTHESIZE PROCESSABLE PHENOLIC RESINS FOR USE AS MATRIX RESINS
IN HIGH PERFORMANCE FIBER REINFORCED COMPOSITES.

PERIOD OF PERFORMRANCE : 12 MONTH

STATUS : PROPOSALS DUE MARCH 26, 1973

TITLE: SYNTHESIS OF IMPROVED POLYESTER RESINS

OBJECTIVE : TO SYNTHESIZE POLYESTER RESINS WITH IMPROVED CHAR FORMING
CHARACTERISTICS.

PERIOD OF PERFORMANCE : 12 MONTH

STATUS : PROPOSALS DUE APRIL 6, 1978

TITLE: SILICONE COPOLYMERS FOR COMPOSITE
MATRIX APPLICATIONS

OBJECTIVE : TO SYNTHESIZE COPOLYMERS INCORPORATING SILICONE RESINS
WITH ENGINEERING RESINS TO PROVIDE MATRIX MATERIALS
FOR ADVANCED FIBER COMPOSITES.

PERIOD OF PERFORMANCE : 12 MONTH

STATUS : PROPOSALS DUE APRIL 3, 1978

TITLE: SURVEY OF INORGANIC POLYMERS

OBJECTIVE : TO SURVEY THE LITERATURE PERTAINING TO INORGANIC POLYMERS
AND TO IDENTIFY POLYMERS WITH HIGH POTENTIAL FOR USE
AS MATRIX RESINS IN ADVANCED COMPOSITES.

PERIOD OF PERFORMANCE : 6 MONTH

STATUS : PROPOSALS ARE BEING EVALUATED

122

LERC

TITLE : ULTRA-HIGH MODULUS ORGANIC FIBERS

OBJECTIVE : TO DEMONSTRATE THE LABORATORY SCALE PRODUCTION OF ORGANIC FIBERS
HAVING TENSILE STRENGTHS AND MODULI IN THE RANGES OF 400 TO
450 KSI AND 25 TO 30 X 10⁶ PSI, RESPECTIVELY.

PERIOD OF PERFORMANCE: 12 MONTH

STATUS : PROPOSALS DUE MARCH 29, 1978

TITLE : HYBRIDIZED POLYMER MATRIX COMPOSITES

OBJECTIVE: TO CONCEIVE, FABRICATE AND EVALUATE HYBRIDIZED POLYMER MATRIX COMPOSITES WHICH EXHIBIT IMPROVED CONSTITUENT MATERIALS' RETENTION CHARACTERISTICS WHEN SUBJECTED TO SEVERE OXIDATIVE ENVIRONMENTS.

PERIOD OF PERFORMANCE : 12 MONTH

STATUS : PROPOSALS DUE APRIL 3, 1978

L24

LERC

PHTHALEIN PMR POLYIMIDES

OBJECTIVE : TO MINIMIZE THE LOSS OF CONSTITUENT MATERIALS FROM GRAPHITE FIBER/ PMR POLYIMIDE COMPOSITES SUBJECTED TO COMBUSTIVE ENVIRONMENTS BY INCREASING THE CHAR YIELD OF THE MATRIX RESIN.

APPROACH: PREPARE PHTHALEIN MODIFIED PMR POLYIMIDES

STATUS : NEW TASK, MONOMERS SYNTHESIS IN PROGRESS

PRINCIPAL INVESTIGATOR : W. ALSTON

LEVEL OF EFFORT : 0.2 MY

IMPROVED PHENOLIC RESINS

OBJECTIVE: TO SYNTHESIZE PHENOLIC RESINS HAVING IMPROVED PROCESSING CHARACTERISTICS

APPROACH : SYNTHESIS OF LOW MOLECULAR WEIGHT PHENOLIC RESIN PRECURSORS HAVING PENDENT OLEFINIC GROUPS CAPABLE OF ADDITION - TYPE POLYMERIZATION

STATUS : NEW TASK - MATERIALS SELECTION IN PROGRESS

PRINCIPAL INVESTIGATOR : PETER DELVIGS

LEVEL OF EFFORT : 0.2 MAN-YEAR

LERC

CHAR FORMING EPOXY MATRIX RESINS

OBJECTIVE: TO MINIMIZE THE LOSS OF CONSTITUENT MATERIALS FROM GRAPHITE
FIBER/ EPOXY COMPOSITES SUBJECTED TO COMBUSTIVE ENVIRONMENTS
BY INCREASING THE CHAR YIELD OF THE MATRIX RESIN.

APPROACHES : INVESTIGATE THE FOLLOWING FOR MODIFICATION OF EPOXY RESINS AND
CURING AGENTS:

- A. PHTHALEIN GROUPS
- B. PHENOLIC RESINS (NOVOLACS)
- C. PHOSPHATES AND PHOSPHATE ESTERS
- D. IMIDES

STATUS : NEW TASK

PRINCIPAL INVESTIGATORS : W. ALSTON AND P. DELVIGS

LEVEL OF EFFORT : 0.4 MY

LERC

IMPROVED POLYESTERS

OBJECTIVE : TO SYNTHESIZE POLYESTER RESINS HAVING IMPROVED HEAT
RESISTANCE AND CHAR - FORMING CAPABILITY

APPROACH: SYNTHESIS OF NEW VINYL - TYPE CURING AGENTS CONTAIN-
ING IMIDE OR QUINOXALINE STRUCTURES

STATUS : NEW TASK - MATERIALS SELECTION AND SYNTHESIS HAVE
BEEN INITIATED

PRINCIPAL INVESTIGATOR : PETER DELVIGS

LEVEL OF EFFORT : 0.3 MAN-YEAR

CHARACTERIZATION OF RESINS FOR GRAPHITE FIBER CONTAINMENT

OBJECTIVE: TO DETERMINE THE MODE AND EXTENT OF DEGRADATION OF CANDIDATE RESINS AND COMPOSITES.

TECHNICAL APPROACH: THE THERMAL AND OXIDATIVE DEGRADATION PRODUCTS EMITTED FROM CANDIDATE RESINS AND COMPOSITES ARE BEING INVESTIGATED USING PYROLYSIS-GC TECHNIQUES. THE AMOUNT OF CHAR RESIDUE ALSO WILL BE MEASURED.

PROGRAM STATUS: PROCEDURES ARE BEING ESTABLISHED. PRELIMINARY RESULTS ON PMR-15 RESINS HAVE BEEN OBTAINED.

PRINCIPAL INVESTIGATOR: R. E. GLUYAS

LEVEL OF EFFORT: 0.3 MY

CHARACTERIZATION OF CHAR RESIDUES

OBJECTIVE: TO DETERMINE THE STRUCTURE AND COMPOSITION OF CHAR RESIDUES FROM CANDIDATE RESINS AND COMPOSITES.

TECHNICAL APPROACH: OPTICAL AND SCANNING ELECTRON MICROSCOPY WILL BE USED TO CHARACTERIZE CHAR RESIDUES. ALSO, THE ELEMENTAL COMPOSITION OF THE CHAR RESIDUES WILL BE ANALYZED.

PROGRAM STATUS: WORK BEING STARTED

PRINCIPAL INVESTIGATOR: R. E. GLUYAS

LEVEL OF EFFORT: 0.1 MY

THERMAL ANALYSIS OF IMPROVED MATRIX RESINS

OBJECTIVE: TO DETERMINE THE REACTIVITY, THERMAL STABILITY AND THERMAL-OXIDATIVE STABILITY OF ORGANIC AND IN-ORGANIC POLYMER MATERIALS.

APPROACH: THERMAL ANALYSES (DSC, DTA, TGA) WILL BE CONDUCTED TO CHARACTERIZE THE THERMAL RESPONSE OF SELECTED POLYMER MATRIX MATERIALS. INITIAL ANALYSES WILL BE DIRECTED TOWARD:

- (A) CHARACTERIZATION OF RESIN CURE.
- (B) CHARACTERIZATION OF THERMAL DEGRADATION.
- (C) CHARACTERIZATION OF THERMAL-OXIDATIVE STABILITY TO DEVELOP CRITERIA FOR RELATIVE STABILITY AND TO CORRELATE THESE ANALYTICAL TEST CRITERIA WITH LARGER SCALE COMBUSTION TESTS.

STATUS: TECHNICAL CAPABILITY ESTABLISHED; INSTRUMENTAL CAPABILITY TO BE EXPANDED; MATERIALS SELECTION IN PROGRESS.

PRINCIPAL INVESTIGATOR: RICHARD W. LAUVER

LEVEL OF EFFORT: 0.2 MY

SPECTRAL CHARACTERIZATION OF HIGH PERFORMANCE MATRIX RESINS

OBJECTIVE: TO CHEMICALLY CHARACTERIZE SOLUBLE MONOMERS, PRECURSORS, AND OLIGOMERS OF ORGANIC AND INORGANIC POLYMER MATERIALS TO ELUCIDATE REACTIONS AND MECHANISMS CRITICAL TO THE PROCESSABILITY AND PERFORMANCE OF THE MATERIALS.

APPROACH: INSTRUMENTAL ANALYSES (NMR, IR, ESCA) WILL BE CONDUCTED TO CHARACTERIZE THE CHEMISTRY OF SELECTED POLYMER MATRIX MATERIALS. INITIAL ANALYSES WILL BE DIRECTED TOWARD:

- (A) PURITY AND REACTIVITY OF MONOMERS AND PRECURSORS.
- (B) IDENTIFICATION OF REACTION MECHANISMS AND SEQUENCE DISTRIBUTIONS IN SELECTED POLYMERS AND COPOLYMERS.
- (C) IDENTIFICATION OF SOLUBLE OXIDATION PRODUCTS OF POLYMERS AND MODEL COMPOUNDS.

STATUS: TECHNICAL CAPABILITY ESTABLISHED; NEW HETERONUCLEAR NMR FACILITY CURRENTLY BEING INSTALLED; MATERIALS SELECTION IN PROGRESS.

PRINCIPAL INVESTIGATOR: RICHARD W. LAUVER

LEVEL OF EFFORT: 0.2 MY

LERC

STRUCTURAL CHARACTERIZATION OF RESINS AND COMPOSITES

OBJECTIVE: TO CHARACTERIZE NEW RESIN SYSTEMS, COMPOSITES AND
COMPOSITE COATINGS BY FOURIER TRANSFORM INFRARED
SPECTROSCOPY.

APPROACH: FOURIER TRANSFORM INFRARED (FTIR) SPECTROSCOPY WILL
BE USED TO OBTAIN MOLECULAR STRUCTURAL INFORMA-
TION ABOUT IMPROVED RESIN SYSTEMS, HYBRIDIZED POLYMER
MATRICES, AND COMPOSITE COATINGS.

PRINCIPAL INVESTIGATOR: KATHERINE E. REED

LEVEL OF EFFORT: 0.2 MY

LERC

DYNAMIC MECHANICAL TESTING OF RESINS AND COMPOSITES

OBJECTIVE: TO EXAMINE THE DYNAMIC MECHANICAL PROPERTIES OF
HYBRID COMPOSITES AND RESIN SYSTEMS.

APPROACH: DYNAMIC MECHANICAL ANALYSIS (DMA) WILL BE USED TO
EXAMINE THE EFFECT OF MIXED RESIN AND OTHER HYBRID
SYSTEMS ON THE TEMPERATURE-DEPENDENT FREQUENCY
AND DAMPING CHARACTERISTICS OF THE COMPOSITE.

PRINCIPAL INVESTIGATOR: KATHERINE E. REED

LEVEL OF EFFORT: 0.1 MY

HYBRIDIZED POLYMER MATRIX COMPOSITES

OBJECTIVE: TO FABRICATE AND EVALUATE HYBRIDIZED POLYMER MATRIX COMPOSITES WHICH EXHIBIT IMPROVED CONSTITUENT MATERIALS RETENTION CHARACTERISTICS WHEN SUBJECTED TO SEVERE OXIDATIVE ENVIRONMENTS.

APPROACH: FABRICATE AND CHARACTERIZE PMR POLYIMIDE AND EPOXY RESIN MATRIX COMPOSITES OF KEVLAR/SILICON CARBIDE, KEVLAR/ALUMINA AND KEVLAR/GRAPHITE FIBERS,

PRINCIPAL INVESTIGATORS: M. P. HANSON
K. J. BOWLES

LEVEL OF EFFORT: 1.1 MY

LERC

POLYMER ADDITIVES FOR FIBER CONTAINMENT

OBJECTIVE: TO INVESTIGATE POLYMER BLENDS AND INORGANIC FILLERS FOR
MINIMIZING LOSS OF CONSTITUENT MATERIALS FROM
GRAPHITE FIBER COMPOSITES SUBJECTED TO COMBUSTION.

APPROACH: PMR POLYIMIDE, EPOXY AND POLYESTER RESINS BLENDED WITH
VARIOUS COMMERCIALY AVAILABLE SILICONE COMPOUNDS
OR INORGANIC FILLERS WILL BE INVESTIGATED FOR:

1. COMPATIBILITY
2. CHAR FORMATION
3. PROCESSABILITY
4. FIBER CONTAINMENT
5. COMPOSITE PROPERTIES

STATUS: WORK INITIATED

PRINCIPAL INVESTIGATOR: R. D. VANNUCCI

LEVEL OF EFFORT: 0.5 MY

LERC

PRELIMINARY BURNING RIG

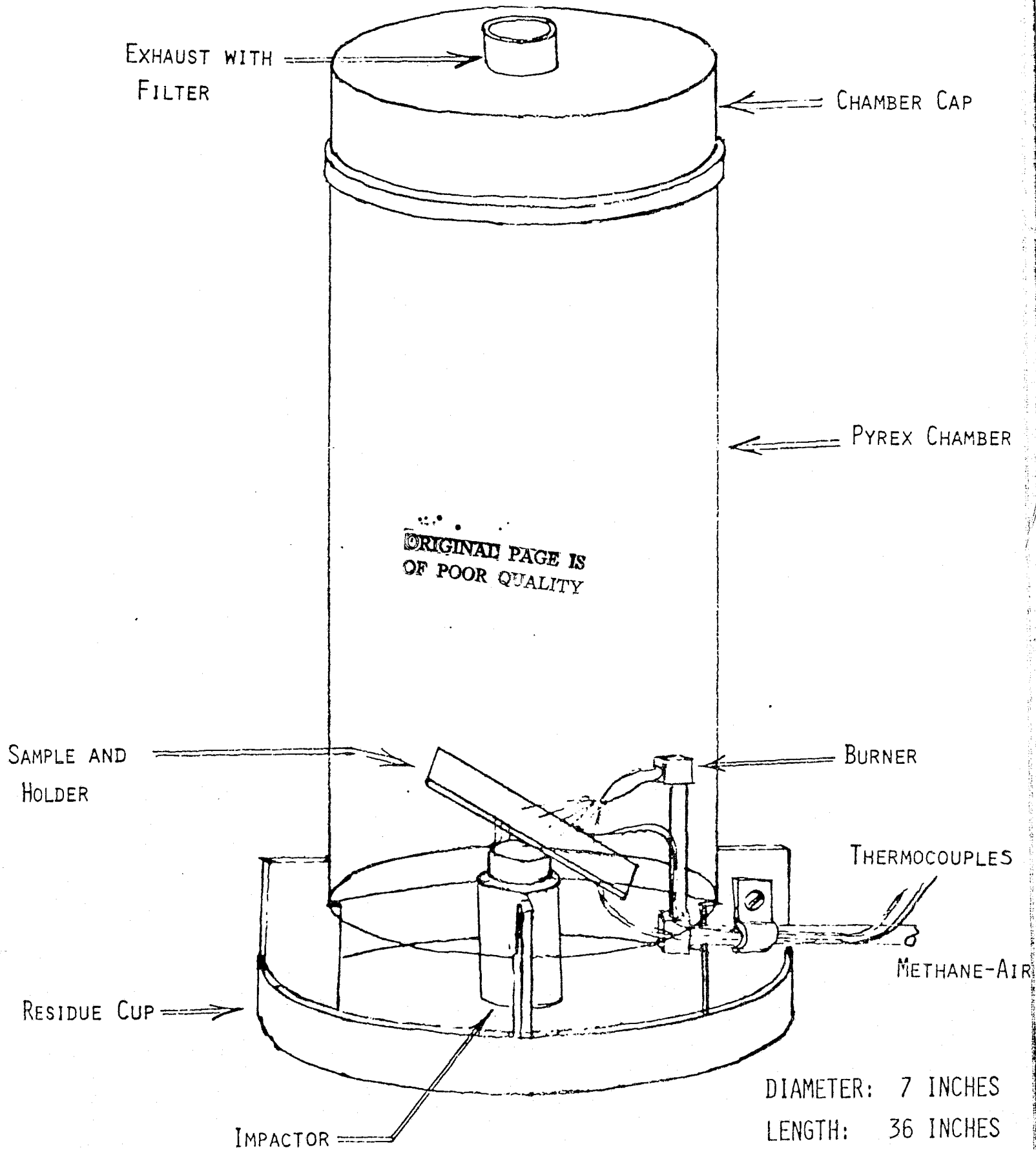

DIAMETER: 7 INCHES
LENGTH: 36 INCHES

BURNER RIG FEATURES

1. SAMPLE VISIBILITY
2. PARTICULATE COLLECTION
 - A) HEPA FILTER & RESIDUE CUP
 - B) SMOOTH INNER SURFACES
 - C) EASY DISASSEMBLY
3. LARGE AIR FLOW
 - A) DIRECT PARTICULATE MATTER TOWARD FILTER
 - B) COOL FLAME PRODUCTS
4. INSTRUMENTATION
 - A) GAS FLOW METERING
 - B) FLAME AND SAMPLE TEMPERATURE MEASUREMENT
 - C) CHAMBER AIR FLOW MEASUREMENT
 - D) FILTER PRESSURE DROP
5. IMPACTOR
 - A) SPRING DRIVEN PISTON
 - B) GAS DRIVEN PISTON
 - C) POSITIONED BELOW SAMPLE
6. HEAT FLOW - UP TO 20 BTU
FT² SEC

SUMMARY OF LEWIS IN-HOUSE PROGRAMS

	LEVEL OF EFFORT IN FY 79 (MY)
RESIN SYNTHESIS	1.1
MATERIALS CHARACTERIZATION	1.1
HYBRIDIZED COMPOSITES	1.6
TOTAL	<hr/> 3.8

FIBER RELEASE TESTING FACILITIES AND RESULTS

V. L. BELL
MARCH 23, 1978

FIBER RELEASE TEST FACILITIES

PROBLEM: HOW TO DETERMINE AMOUNTS AND TYPES OF GRAPHITE FIBERS FROM CIVILIAN AIRCRAFT CRASH/FIRE SITUATIONS ?

EXPERIENCE: NO KNOWN CRASHES OF CIVILIAN AIRCRAFT WITH GRAPHITE COMPOSITE PARTS.
SEVERAL CRASHES OF MILITARY AIRCRAFT RELEASED FREE GRAPHITE FIBERS.

TEST LIMITATIONS: NATIONAL MORATORIUM ON OUTDOOR RELEASE OF GRAPHITE FIBERS EXCEPT UNDER RIGIDLY CONTROLLED CONDITIONS.

ACTIVE FIBER RELEASE TEST FACILITIES

- LABORATORY/EXPLORATORY - NAVAL RESEARCH LABORATORY
(DR. J. P. REARDON)

- CHAMBER/INTERMEDIATE - NAVY - DAHLGREN, VIRGINIA
(DR. K. R. MUSSELMAN)

- OUTDOOR/RANGE - TRW - AF - NAVY/CHINA LAKE
(DR. PAUL LIEBERMAN)

LABORATORY TESTING AT NAVAL
RESEARCH LABORATORY

143

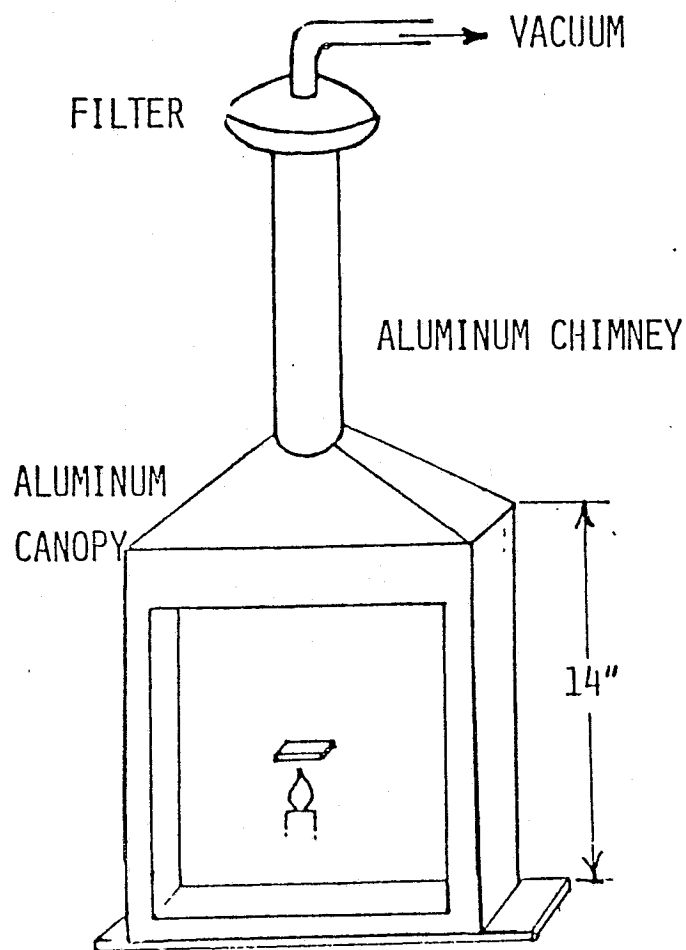

SAMPLE SIZE: 2" X 2" X 1/4"

FUEL: PROPANE, JP-5

EFFECTS STUDIED: COMBUSTION TIME

FIBER RELEASE

SPONTANEOUS IGNITION
TEMPERATURE

CHAR FORMATION

COMPOSITE CONSTRUCTION

ELECTRICAL PROPERTIES

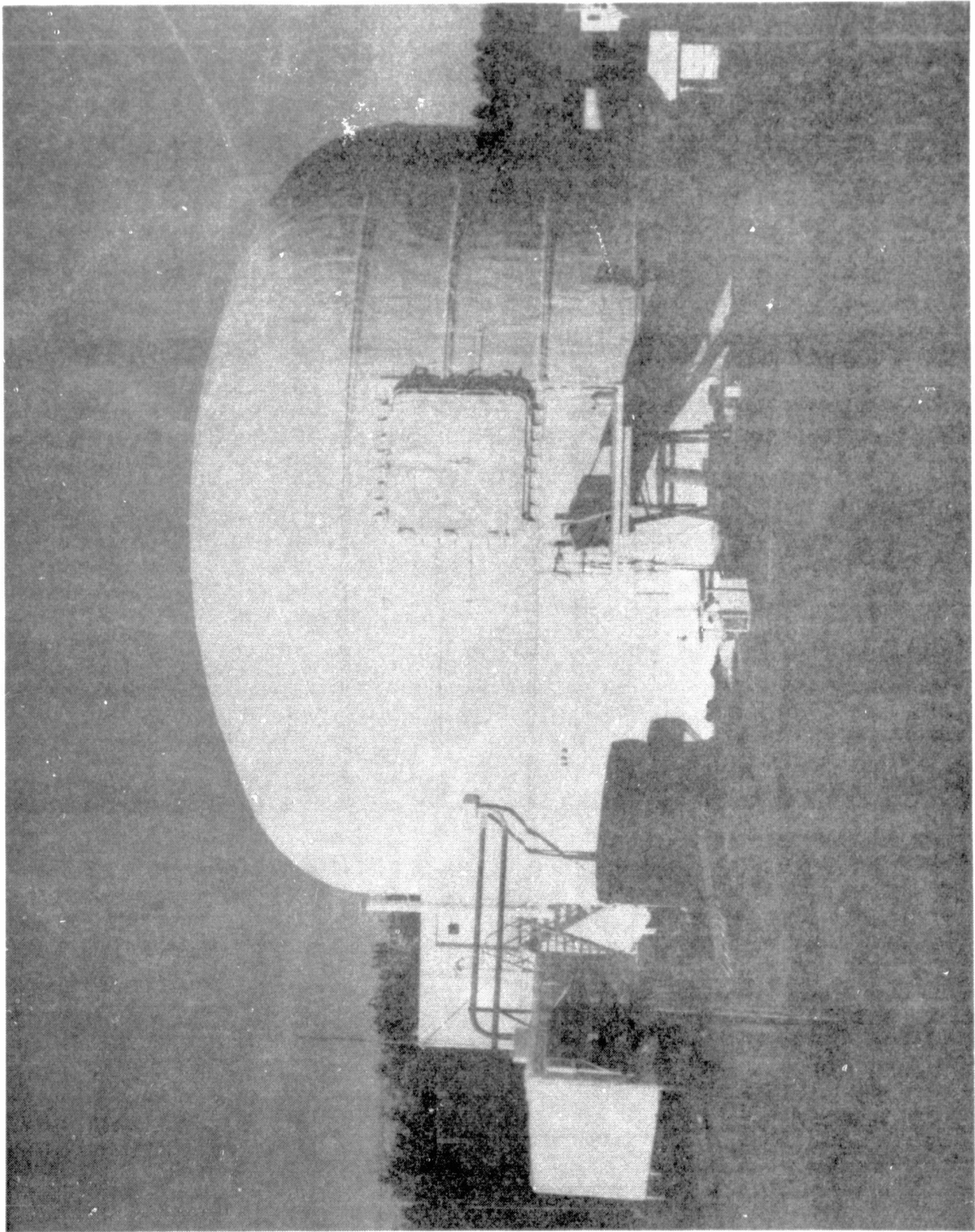

144

ORIGINAL PAGE IS
OF POOR QUALITY



145

**ORIGINAL PAGE IS
OF POOR QUALITY**

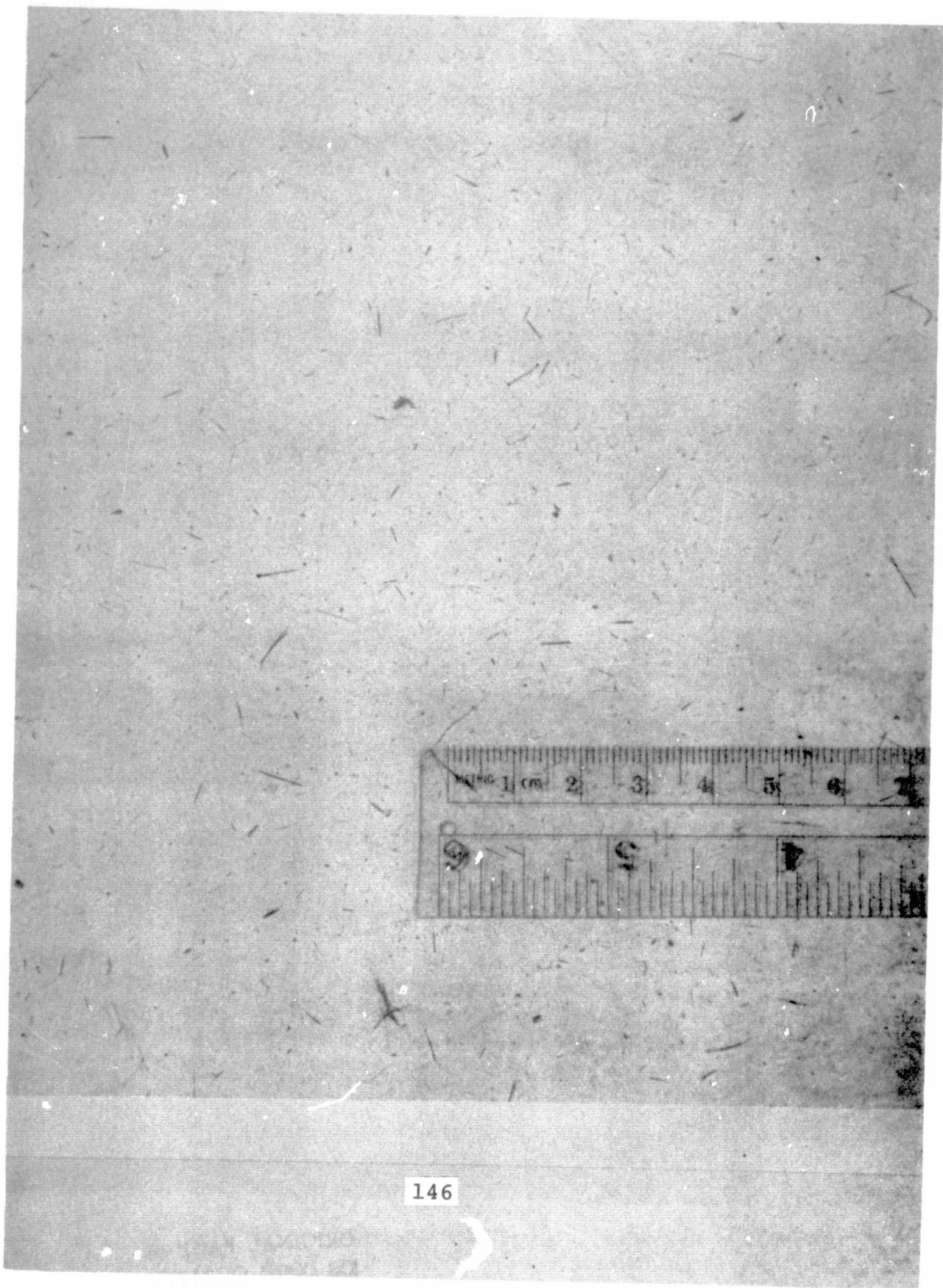

146

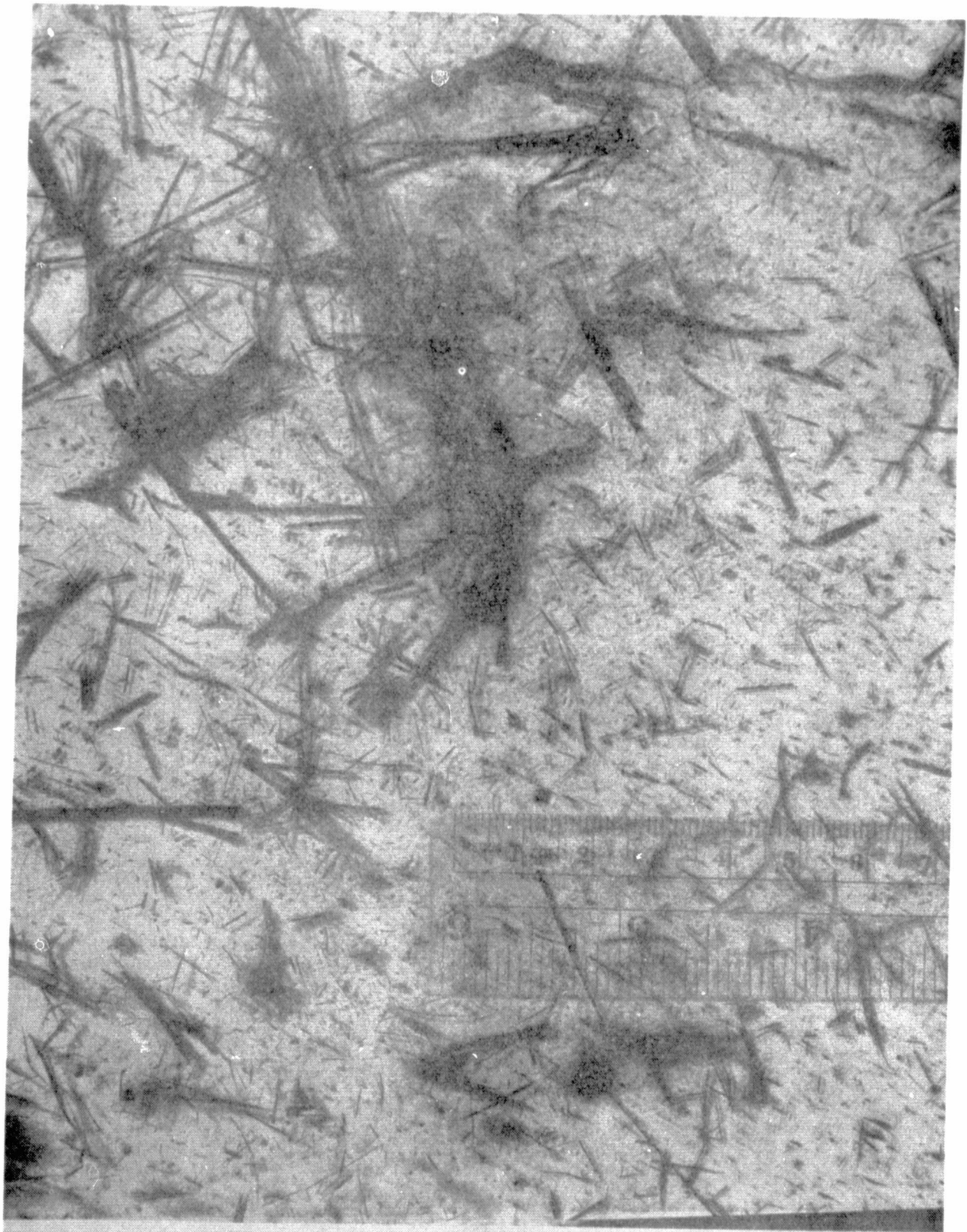

147

ORIGINAL PAGE IS
OF POOR QUALITY

NAVY/DAHLGREN CHAMBER TESTS

TEST FIXTURE: SAMPLE HOLDER
 FUEL PAN OR GAS BURNER
 EXPLOSIVE DELIVERY ARM

TEST PROCEDURES: STATIC UNBURNED/EXPLODED
 STATIC BURNED/EXPLODED
 DYNAMIC BURNED/EXPLODED
 STATIC BURNED

RESIDUE COLLECTION: GRID OF 8.9 cm PETRI DISHES (24)
 0.91 m GRID - 15.2 X 20.3 cm SHEETS (107)
 ADHESIVE-BACKED CELLULOSE ACETATE
 HAND PICKUP OF LARGE FRAGMENTS
 BROOM SWEEP OF FIBROUS MATERIALS
 POWER VACUUM SWEEP

COMPOSITE MATERIAL GROUPINGS

1. SINGLE FIBERS
2. LINT
3. BRUSH/CLUMP
4. BLAST FRAGMENTS
WIDTH < 2mm
5. BLAST FRAGMENTS
WIDTH = 2-7mm
LENGTH < 25.0mm
6. LAMINAR
WIDTH > 7mm
LENGTH > 17.0mm

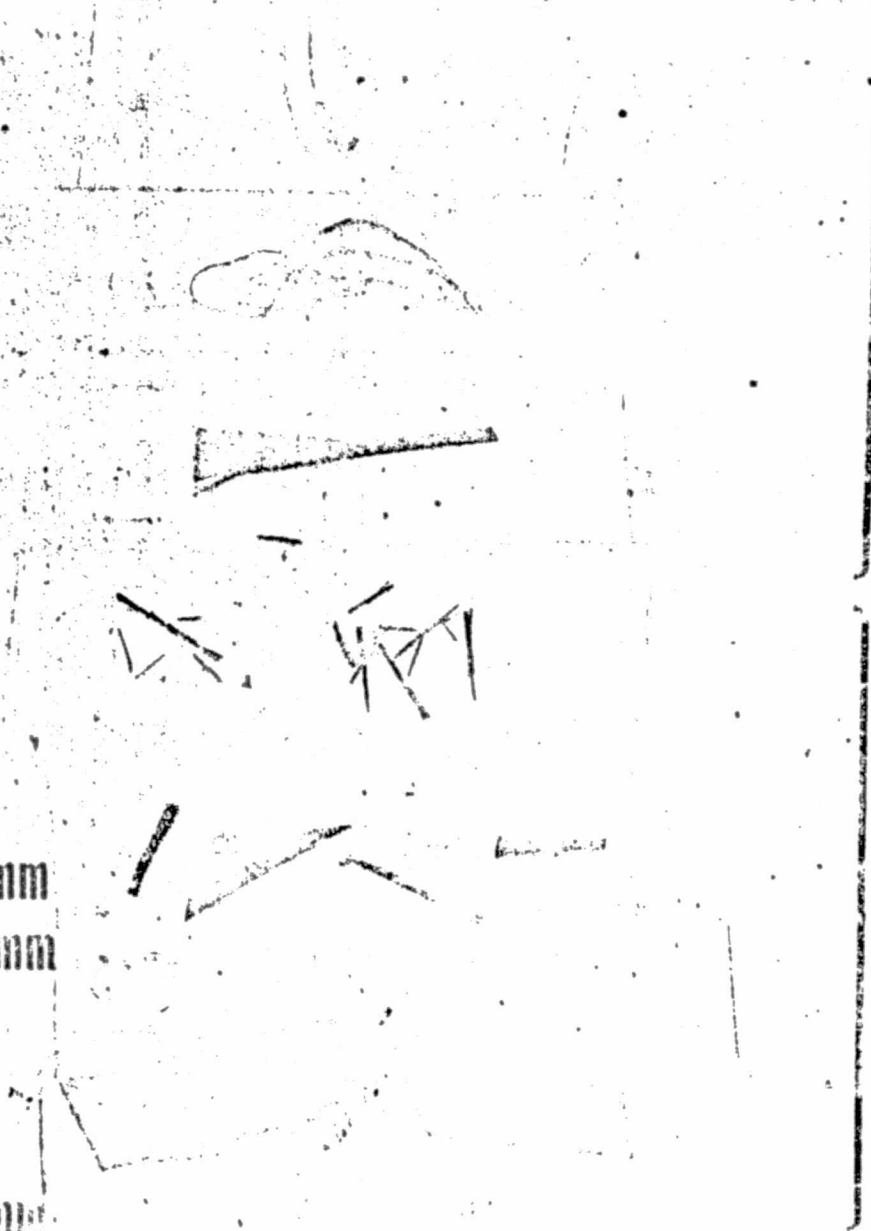

100%

ORIGINAL PAGE IS
OF POOR QUALITY

0.0%

COMPOSITE MATERIAL GROUPINGS

1. SINGLE FIBERS

2. LINT

3. BRUSH/CLUMP

4. BLAST FRAGMENTS
WIDTH < 2mm

5. BLAST FRAGMENTS
WIDTH = 2-7mm
LENGTH < 25.0mm

6. LAMINAR
WIDTH > 7mm
LENGTH > 17.0mm

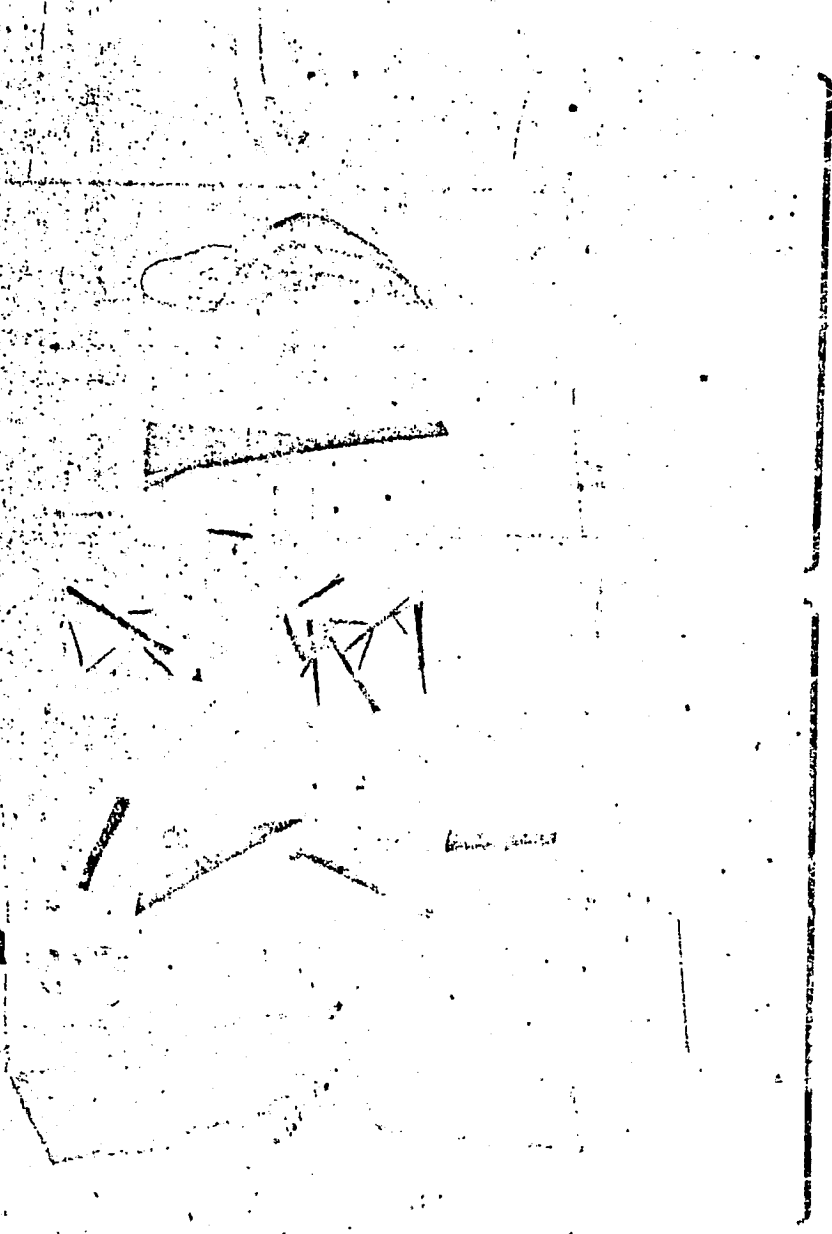

100%
100%

ORIGINAL PAGE IS
OF POOR QUALITY

0.0
0.0

GRAPHITE FIBER MODIFICATIONS
DR. R. J. DIEFENDORF, CHAIRMAN

NAME	ORGANIZATION
Roger T. Pepper	FMI Maine
Dennis Riggs	AMMRC
John Hurt	Army Research Office
J. R. Leal	Celanese Research Co.
L. H. Peebles	ONR/Boston
F. L. Vogel	Univ. of PA
H. P. Edelstein	DWT Naval Ship R&D Center
Judd Diefendorf	Renssalaer Polytechnic Institute
Brian Ence	George Washington University
J. T. Paul	Hercules Research Center
S. M. Rozowski	Ball State University
D. B. Fischbach	Univ. of Washington
D.M. Estering	George Washington University
W. D. Lee	US Army, MERADCOM
W. C. Schwemer	Vought Advanced Technology Center
C. A. Gaulin	Aerospace Corp.
R. Prescott	Great Lakes Research
Bill Chard	Battelle Columbus Lab
Guilio Varsi	Jet Propulsion Lab
Fred Hansen	NASA Ames
NASA Reporters:	W.D. Brewer and R. K. Clark, LaRC

3/23/78

ISSUES FOR
GRAPHITE FIBER MODIFICATION
WORKING GROUP

1. Upon what principles might the electrical conductivity of graphite fibers be reduced?
2. What treatments should be investigated as applications of these principles?
3. For each treatment:
 - (a) What are the likely effects on fiber mechanical properties?
 - (b) What are the prospects for reducing the conductivity by a factor 10, 100, or 1000?
 - (c) What are the prospects for retention of effectiveness after exposure to the high temperature encountered in a burning composite?
 - (d) What is the likely impact on production costs?
 - (e) What will be the effect on fiber matrix bonding?
4. Considering the aspects raised in issue 3 above, which treatments do you recommend for detailed investigation?
5. Can larger diameter fibers be produced without significant reductions in mechanical properties and handleability?
6. Can the cross-sectional shape of the fibers be altered so that their aerodynamic characteristics would be changed?
7. Could selected surface imperfections be introduced so that fibers would be less resistant to fire?
8. Can additives be used in the precursor that would make the fibers less resistant to fire?
9. What is your assessment of the current NASA research program in this area, and what changes do you recommend?
10. Rank the different generic (fiber modifications, fiber coatings, alternative fibers, epoxy resin modifications, epoxy resin replacements, hybrid composites) solutions as to their probability of success.

NASA REPORTERS' SUMMARY FOR
GRAPHITE FIBER MODIFICATION WORKING GROUP

Two presentations were given prior to the working group general discussions. Roger Prescott of Great Lakes Carbon gave a summary of his company's experience with graphite fibers. Donald Esterling of George Washington University discussed his plans for hydrogenation of graphite fibers for increased electrical resistivity.

The focus of the fiber modification working group was on ways to alter the electrical, oxidative, and disseminative properties of graphite fibers. In particular, emphasis was placed on ways to increase the electrical resistivity of the fibers to eliminate the electrical hazards even though the fibers may be released to the environment, and on decreasing the stability of the fibers so that they would likely burn up in a fire and not be released. Changing the size and shape of the fibers to minimize the area over which they are disseminated was discussed briefly.

At the outset, the group recognized the importance of understanding the fundamentals of electrical conductivity and oxidative properties of graphite fibers. It was also noted that better definitions are required of what levels of resistivity are acceptable and of what the exposure conditions are in an actual fire.

INCREASED RESISTIVITY

Four potential solutions to the graphite fiber problem by way of fiber modification to increase electrical resistivity were identified:

1. Low temperature heat treatment
2. Hydrogenation
3. Conversion to graphitic oxide
4. Doping

Low Temperature Heat Treatment.- It was suggested that by heat treating at low temperatures, the defect substructure of carbon fibers could be retained while maintaining the preferred orientation necessary for good mechanical

properties. Increasing the defect concentration should significantly increase the electrical resistivity. The group consensus was that this technique could readily produce changes in resistivity by a factor of 10 or 20 and possibly 100. However, changes of three orders-of-magnitude or more were considered very unlikely. In addition, it was thought that the resulting fibers could be of significantly lower-strength than those treated at higher temperatures. It was also suggested that the low temperature heat treatment results in a less stable fiber which should be consumed more readily in a fire. It was noted that the environment in a large pool fire is reducing (oxygen depleted) and it is doubtful that even an oxidation-susceptible fiber would be consumed. An oxidation-susceptible fiber may be consumed upon incineration of composite scrap. The question was raised as to whether or not changes in the wavelength and amplitude of the "undulating ribbons" in the fibers could affect the resistivity (crystallite scattering). For a number of reasons, the group thought that it was unlikely that ribbon changes would have any significant effect. The primary reason is that the mean free path of a carrier electron is probably shorter than the shortest wavelength one could produce in a ribbon and electron interactions with other defects predominate.

The low temperature heat treatment technique was considered to be the most advantageous as far as manufacturing is concerned. In fact, the carbon producers indicated that such a process would be welcomed and would have little impact on the cost of the fibers.

Hydrogenation of Fibers.- Electrical conduction is thought to be associated, in part, with the migration of electron holes created by surface defects such as unsatisfied chemical bonds, improperly coordinated atoms, etc. Those defects tend to trap electrons, creating holes by which electricity can be conducted. It was suggested that if these traps can be eliminated, the resistivity can be significantly increased. The procedure would be to introduce hydrogen into the fibers, to lock onto those dangling bonds, thus removing acceptor sites and eliminating the holes. The details of the hydrogenation procedure were not defined; however, it is likely that the fibers would be exposed to a hydrogen atmosphere at about 1000°C and 1 or 2 atmospheres pressure for about 1/2 hour. It could not be said whether or not there would be any effect, but the effect, if present could potentially be large.

The working group was not aware of any successful attempt to hydrogenate graphite. The question was also

raised as to whether the hydrogenation process would be reversed in a fire. No one had anything firm to say about this question, but it was thought that if the hydrogen could be put in, it would probably stay.

The carbon manufacturers noted that whatever process was used, it would not be cost effective because of the hazards of working with hydrogen at high temperatures. They felt that, at present, hydrogenation would not be a viable approach from the manufacturing standpoint. The feeling of the group was that this approach had a small probability of success, but encouraged continuation of the work.

Conversion of Fibers to Graphitic Oxide.- The general procedure is to expose fibers to strong oxidizing solutions for a few minutes. The oxygen apparently enters between the graphite layers, locks onto loose double bonds, and eliminates current carriers. There are two positive features about this approach. First, available literature indicates that increases in resistivity of several orders of magnitude are possible.

Second, the graphitic oxide may be inherently less stable and burn up in a fire. Even if the exposure conditions were reducing, the fiber itself may be a sufficient source of oxygen to cause it to burn. The question was raised as to whether this instability would allow the fiber to survive fabrication. No one could say with any confidence what would happen in fabrication or in a fire. The major concerns about this approach were the instability and possible degradation of mechanical properties. At present, these are unknown factors.

The graphitic oxide approach would be expensive, again because of working with potentially explosive mixtures. However, the problems could probably be overcome in a production process.

In general, the group considered the graphitic oxide approach to have some promise. There were some suggestions to investigate perhaps fluorine, nitrogen or sulfur in addition to oxygen.

Doping.- This approach attempts to remove positive or negative carriers by introducing electron donor or acceptor atoms into the graphite structure. Doping was suggested, but was discussed very little by the group. It was suggested that there were some dopants such as nitrogen or boron and nitrogen together which could be beneficial.

DECREASED STABILITY AND CHANGES IN SHAPE AND SIZE

The group felt that introducing additives into precursors or introducing surface imperfections in fibers are probably not viable approaches for making fibers less resistant to fires. Surface imperfections would no doubt degrade fiber strength significantly and precursor additives may not be effective in a reducing (oxygen depleted) atmosphere.

The working group briefly considered changing the shape and size of fibers to alter the aerodynamic characteristics. It was decided that a circular cross-section fiber would have the greatest fall rate, and there is no incentive to produce fibers with different shapes. Fiber diameter could be increased by a factor of 2 while maintaining reasonable mechanical properties, probably without greatly affecting cost. However, producing fibers with changes in diameter greater than a factor of two would be prohibitively time consuming and costly.

In general, the potential solutions proposed by the Fiber Modification Working Group were not considered to be short term fixes. The expected time frame and cost for conducting feasibility studies, process development, and materials qualification program for just one approach was considered to be 2-5 years and \$2M.

CONCLUSIONS

1. Fiber modification does not hold much promise for complete solutions to the graphite fiber problems.
2. Of the potential solutions discussed, the graphitic oxide appears to have the best chance of success in meeting electrical requirements.
3. Changes in fiber resistivity by a factor of 10 are achievable. Changes of more than two orders of magnitude are unlikely.
4. Introducing additives to reduce fiber stability is probably not a viable approach.
5. Changing size and shape of fibers is not likely to significantly improve the fall rate characteristics.
6. The proposed potential solutions are not short term fixes even if they work. The expected time frame and cost for just one approach to be fully developed is considered to be 2-5 years and \$2M.

RECOMMENDATIONS

1. Continue concentrated research efforts in all the areas discussed.
2. Research should be conducted by university, government or other research labs (as opposed to fiber manufacturers).
3. Fiber manufacturers should be consulted and become actively involved when the feasibility of an approach has been demonstrated.
4. Rapid and effective information transfer between persons and organizations working on graphite fiber modification should be maintained through:
 - (a) informal bimonthly newsletters
 - (b) group meetings of actual researchers

REPORT OF
GRAPHITE FIBER MODIFICATION
WORKING GROUP

R. J. DIEFENDORF, CHAIRMAN

GRAPHITE FIBER MODIFICATIONS

- o LOW TEMPERATURE HEAT TREATMENT
- o DOPING
- o HYDROGENATION
- o GRAPHITIC OXIDE

DISCUSSION TOPICS

(TECHNICAL)

- o CONDUCTIVITY
- o OXIDATION
- o DISSEMINATION

CONDUCTIVITY

o CHARGE CARRIER (WHERE FROM?)

o GRAPHITE

- FEW CARRIERS
- HIGH MOBILITY

o CARBON

- MANY CARRIERS
- LOW MOBILITY

POSSIBLE SOLUTIONS

- 0 DOUBLE BONDS
GRAPHITIC OXIDE
- 0 DANGLING BONDS
HYDROGENATE
- 0 NITROGEN COMPENSATION
- 0 LOW TEMPERATURE HEAT TREATMENT
- 0 CRYSTALLITE SCATTERING

PROBABILITY OF
CONDUCTIVITY CHANGE

10 X - EXCELLENT

100 X - FAIR

1000 X - POOR

FIRE SURVIVABILITY

(REDUCING CONDITIONS)

- o HIGHER OXIDIZABILITY
- o LOWER HEAT TREATMENT TEMPERATURE
- o ADDITIVES

FIBER DISSEMINATION

- o SHAPE - ROUND BEST
- o MASS - LARGER DIAMETER

COSTS PER MODIFICATION

FEASIBILITY

PROCESS DEVELOPMENT

QUALIFICATION



$\$2 \times 10^6$

INFORMATION TRANSFER

- 0 BIMONTHLY INFORMAL REPORTS
- 0 GROUP MEETINGS

RANKING OF GENERIC SOLUTIONS

(1 - 3 BASIS)

	<u>RANK</u>
FIBER MODIFICATION	1.94
FIBER COATING	1.82
ALTERNATE FIBERS	1.35
EPOXY MODIFICATION	2.53
EPOXY REPLACEMENT	2.53
HYBRIDS	1.71

HYDROGENATION OF CARBON FIBERS

by

D. M. Esterling
The George Washington University

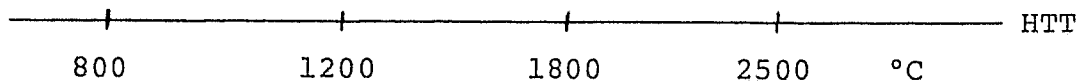

Organic
Hopping

Graphite Band
Overlap (Hole
Carriers)

What are charge carriers?

What is conduction mechanism?

How are the carriers introduced?

(Band overlap vs. defects vs. impurities (N))

Different answers for different HTT.

Sensible way to decrease σ for HTT 2,500 °C (e.g. introduce impurities) may be exactly wrong at HTT of 1400 °C.

High HTT - High mobility, few carriers (Little hope, only small changes in σ at best).

Low HTT (≤ 1800 °C) - lower mobility, many carriers.

Electron states

- Gap?
- Continuous $\left\{ \begin{array}{l} \text{Localized (Mott/Anderson)} \\ \text{Delocalized} \end{array} \right.$

Conduction - Holes in disordered system

Origin of holes - acceptor sites of unknown origin (electron traps)

- Surface?
- $\left\{ \begin{array}{l} \text{Dangling Bonds?} \\ \text{Improperly coordinated atoms?} \end{array} \right.$

Remove electron traps by eliminating defects.

Hydrogen Bonds - Saturate dangling bonds (fill electron trap with electron that is not coming from carbon chain)

- Why not dope with donor atoms (alkalals)
- Really looking for chemical effect (Local change in structure). Dopants give global change in electron density..

How?? 900° - 1000 °C @ 1 ATM H₂ (No Catalyst)

400° - 500 °C @ 1 ATM H₂ (Catalyst)

GRAPHITE FIBER COATING & ALTERNATIVE FIBERS

Dr. James Economy, Chairman

NAME	ORGANIZATION
Sam C. Aker	Bell Helicopter
Robert Curley	McDonnell Douglas Corp.
James Economy	IBM Research Lab.
Frank Galasso	United Technologies
James V. Gauchel	DeSoto Inc.
John H. Gaul, Jr.	Dow Corning Corp.
Max F. Grandey	General Electric Co.
Robert S. Hamilton	Carborundum Corp.
Lee McKague	General Dynamics
Paul E. McMahon	Celanese Research Co.
Roger T. Pepper	Fiber Materials, Inc.
Kumar Ramokalli	Jet Propulsion Lab.
S. R. Riccitiello	NASA Ames
V. N. Saffire	General Electric Co.
John T. Schell	NASA Marshall
Richard J. Shuford	Army Mat. & Mech. Research Center
Robert A. Simon	Naval Surface Weapons Center
R. V. Subramanian	Washington State University
Raymond J. Suplinskas	AVCO Specialty Materials
R. J. Tomerlin	Bell-Helicopter Textron
Herbert F. Volk, Sr.	Union Carbide Corp.
Charles B. Whitset	McDonnell Douglas Corp.
NASA Reporters:	S. S. Tompkins and C. M. Pittman, LaRC

ISSUES FOR
GRAPHITE FIBER COATING ALTERNATIVE FIBERS
WORKING GROUP

1. What high electrical resistance coatings can be applied to graphite fibers? How thick would they need to be? What coating method would be employed?
2. Which of these coatings is likely to remain intact after fire and explosion?
3. Which of these coatings can be readily applied during the fiber manufacturing process?
4. What precursor coatings can be applied that would convert to a high electrical resistance coating in-situ during fire and explosion?
5. What coatings can be applied that might result in fiber "clumping" as a result of exposure to fire and explosion?
6. For all types of coatings considered, what is the likely effect on fiber-matrix bonding?
7. What other fibers (e.g., BN, Kevlar, SiC) should be considered as alternatives to graphite? What are their advantages and disadvantages?
8. Rank the potential replacement fibers as to the probability that they could be incorporated into the ACEE program.
9. Would hollow glass or graphite fibers be worth developing as a potential solution?
10. What is your assessment of the current NASA research program in this area, and what changes do you recommend?
11. Rank the different generic solutions (fiber modifications, fiber coatings, alternative fibers, epoxy resin modifications, epoxy resin replacements, hybrid composites) as to their probability of success.

NASA REPORTERS' SUMMARY FOR FIBER COATINGS
AND ALTERNATIVE FIBERS WORKING GROUP

Four presentations preceded the working group open discussions. Kumar Ramokalli discussed work at JPL on coating graphite fibers to increase electrical resistivity as well as to promote clumping of fibers to reduce their dissemination. R. V. Subramanian of Washington State University discussed an electrolytic technique for coating fibers with a polymer. Robert Hamilton of Carborundum discussed his company's development of a BN fiber. Ashok Dhingra gave a report on DuPont's development of Kevlar and FP (Al_2O_3) fibers as possible replacement for graphite.

COATINGS

The working group discussions of coatings were directed toward four areas:

1. Inorganic coatings - SiC , B, B_4C , BN, Si_3N_4 , SiO_2
2. Organic and metallorganic coatings to provide a high density char layer on the fiber surface.
3. Metallic coatings - Al, Cr, Ni
4. Catalytic coatings to increase the fiber oxidation rate.

Items 1 and 2 received the most attention. The rationale for using metallic coatings, item 3, was the possibility of forming a metal oxide on the fiber surface during a fire. However, considerable doubt was expressed as to whether sufficient oxygen would be available to form the oxide. Catalytic coatings, item 4, were thought to be more in the province of the fiber modification working group and were only briefly discussed.

Inorganic Coatings.- The consensus of the working group was that the inorganic coating work, underway or being initiated, includes the most promising coating materials. These coating materials include:

1. SiC
2. B
3. B_4C
4. BN
5. Si_3N_4
6. SiO_2
7. Metallic silicates

The working group felt that the coating efforts should critically examine:

1. The effect of the coating on composite mechanical properties.
2. The effect of the coating on fiber release, fall rate, and electrical properties.
3. The effect of the coating on cost.
4. The chemical stability of nitride coatings.

Organic Coatings Which Char.- The objective of this work is to find an organic coating which, when charred, would facilitate fiber clumping and/or act as an insulative coating. The coating must have a high char yield and also provide an effective fiber-matrix bond. The group encouraged continued work on silicones, high temperature polymers such as polybenzimidazole (PBI) and polyphenylquinoxaline (PPQ) and evaluation of new techniques of electrolytic polymer coating deposition.

Alternate Fibers

The alternate fibers which were discussed included:

1. BN fibers
2. High modulus organic fibers
3. $\alpha\text{Al}_2\text{O}_3$ (FP fibers from DuPont)
4. SiC - both large and small diameter fibers
5. B fibers with a carbon core
6. Glass fibers
7. B_4C fibers
8. 33 μm carbon fibers
9. AlB_2 flakes

These alternate fibers are listed more or less in the order in which the working group felt that the fibers showed the most promise. Boron and glass fibers were not discussed extensively. The general consensus was that these fibers are available and should be considered for some applications. The large diameter carbon fibers, item

8, were mentioned because of their potential for increasing the fiber fall rate, however, their mechanical properties would require substantial improvement. The AlB_2 flakes were mentioned in connection with a hybrid composite of AlB_2 flakes and carbon fibers. This approach could reduce the amount of carbon fibers and, therefore, reduce the risk.

BN Fibers.- Carborundum has prepared small experimental samples of BN fibers with the following properties.

E = 30-50 Msi
 σ = 300 ksi
 ρ = 1.8 g/cc

The primary advantage of BN fibers is that they are very similar to carbon fibers and therefore, would probably perturb the present composite technology less than any other alternate fiber. The main disadvantage of BN fibers is that at least 4-5 years of work would be required to develop a commercial fiber at the present research pace.

High Modulus Organic Fibers.- DuPont has five new experimental fibers with the following properties:

E = 20-30 Msi
 σ = 300-600 ksi
 ρ = 1.22-1.48 g/cc

One or more of these fibers could replace carbon in some applications. However, these fibers have poor compression properties, and composite fabrication technology would require development. The working group recommended that these fibers be evaluated in hybrid configurations because of the low fiber modulus.

α Al_2O_3 (FP) Fibers. -DuPont has developed Al_2O_3 yarn which is cost competitive with carbon fiber and has the following properties:

E = 55 Msi
 σ = 200 ksi (300 ksi expected with smaller diameter)
 ρ = 3.9 g/cc
diameter = 20 μ m

This fiber could be commercially available in the very near future. The disadvantages of FP fibers are their high density and brittleness. The recommendation of the working group was to evaluate FP fibers in hybrids in an attempt to improve composite fracture strain.

SiC Fibers.- AVCO has developed a 130 μm SiC (carbon core) fiber with the following properties:

$$\begin{aligned} E &= 50-60 \text{ Msi} \\ \sigma &= 500 \text{ ksi} \\ \rho &= 3.2 \text{ g/cc} \end{aligned}$$

The advantages of this fiber are its excellent mechanical properties. The disadvantages are the large fiber diameter and high density. The working group recommended that these fibers be evaluated in hybrid composites and that a small diameter SiC fiber be developed. (Japan has reportedly developed a small diameter SiC fiber.)

B₄C Fibers .- A continuous filament B₄C yarn, with the following properties has been reported:

$$\begin{aligned} E &= 40-55 \text{ Msi} \\ \sigma &= 300-400 \text{ ksi} \\ \rho &= 2.28 \text{ g/cc} \\ \text{yarn} &= 720 \text{ ends, } 9 \mu\text{m diameter} \end{aligned}$$

The advantages of this yarn are that the properties are similar to carbon fibers. The disadvantages are that only a laboratory process has been defined and 2-3 years are required for scale-up. Also the fibers will be more expensive than carbon. The working group recommended that a cost analysis, including production scale-up, be made to determine B₄C fiber feasibility.

CONCLUSIONS

1. No particular coating is presently favored over any other.
2. No coating should be eliminated without more information and tests.
3. BN fibers should be considered a long term substitute for carbon. Other alternate fibers should only be considered for hybrid composites.

4. Any change in fiber or coating is necessarily a long term solution (3-5 years).

5. A critical lack of quantitative information on the properties required to alleviate the electrical hazard is apparent. For example:

a. How much must the overall fiber resistance be increased?

b. How much fiber clumping is required and how many fibers make a clump?

c. How much must the settling rate be increased?

Answers to these and similar questions should be obtained as soon as possible so that the research effort can proceed toward known objectives.

RECOMMENDATIONS

The working group made the following recommendations.

Continue work on:

1. Inorganic coatings
2. Organic coatings
3. Organometallic coatings
4. BN fibers

Initiate programs on:

1. Hybrid composites of high modulus organic fibers with B (carbon core) fibers, SiC (carbon core) fibers and Al_2O_3 (FP) fibers.

2. Producing small diameter SiC fibers.

3. B_4C yarn cost analysis and production scale-up.

REPORT OF
GRAPHITE FIBER COATING & ALTERNATIVE FIBERS
WORKING GROUP

Dr. JAMES ECONOMY, CHAIRMAN

GRAPHITE FIBER COATING AND ALTERNATIVE FIBERS

OVERVIEW

COATINGS

- 0 INORGANIC: SiC, B, B₄C, BN, Si₃N₄, SiO₂
- 0 ORGANIC/METALLOORGANIC: HIGH CHAR
- 0 METALLIC: Al, Cr, Ni
- 0 CATALYTIC: OXIDATION OF CARBON
- 0 SEVERAL POINTS OF CONCERN

ALTERNATIVE FIBERS

- 0 HIGH MODULUS ORGANICS
- 0 BN
- 0 α Al₂O₃ (FP)
- 0 SiC LARGE, SMALL DIAMETER
- 0 B (CARBON CORE)
- 0 GLASS
- 0 B₄C
- 0 33 μ m CARBON
- 0 AlB₂ FLAKES

178 ORIGINAL PAGE IS
OF POOR QUALITY
ORIGINAL PAGE IS
OF POOR QUALITY

INORGANIC COATINGS

o PROGRAMS INITIATED AT JPL, AVCO, UTC AND UCC ON

SiC
B
B₄C
BN
Si₃N₄
M₂Si₂O₃

o CRITICAL ISSUES

- COATING THICKNESS VS. VOLTAGE
- EFFECT ON STRENGTH
- CHEMICAL STABILITY OF NITRIDES
- POTENTIAL FOR CLUMPING
- COATING PROCESS/COST

ORIGINAL PAGE IS
OF POOR QUALITY

ORGANIC COATINGS WHICH CHAR

- PURPOSE:
- o WOULD BE REQUIRED FOR CHAR FORMING MATRIX
 - o MAY FACILITATE CLUMPING
 - o CHAR MAY ACT AS INSULATOR

- REQUIREMENTS:
- o HIGH CHAR YIELD
 - o EFFECTIVE FIBER-MATRIX BOND

RECOMMENDATIONS:

- o CONTINUE STUDIES ON SILICONE
- o EVALUATE HIGH TEMPERATURE POLYMERS AS COUPLERS, PBI, PPQ
- o EVALUATE NEW TECHNIQUES TO IMPROVE INTERLAMINAR SHEAR PROPERTIES, ELECTROLYTIC POLYMERIZATION

HIGH MODULUS ORGANIC FIBERS

DUPONT HAS FIVE NEW EXPERIMENTAL FIBERS

E 20 - 30 msi

σ 300 - 600 ksi

ρ 1.22 - 1.48 g/cc

ADVANTAGES: COULD REPLACE CARBON IN CERTAIN AREAS

DISADVANTAGES: POOR COMPRESSION PROPERTIES, BONDING

RECOMMENDATION: EXPLORE IN HYBRIDS.

BN FIBERS

CARBORUNDUM HAS PREPARED SMALL EXPERIMENTAL SAMPLES OF HIGH
MODULUS BN FIBERS

E 30 - 50 Msi

σ 300 ksi

ρ 1.8 g/cc

182

ADVANTAGES: BN FIBER IS VERY SIMILAR TO GRAPHITE

DISADVANTAGES: 4 - 5 YEARS OF DEVELOPMENT REQUIRED AT PRESENT PACE

PLAN: NASA/ONR PLANNING JOINT SUPPORT

α Al₂O₃ (FP)

DUPONT HAS DEVELOPED Al₂O₃ YARN COST COMPETITIVE WITH GRAPHITE FIBER

E 55 Msi

σ 200 ksi (300 ksi SEEN)

ρ 3.9 g/cc

DIAMETER 20 μ m

ADVANTAGES: AVAILABLE IN VERY NEAR FUTURE

DISADVANTAGES: HIGH DENSITY, BRITTLENESS

RECOMMENDATIONS: EVALUATE IN HYBRID
IMPROVE FRACTURE STRAIN

SiC

AVCO HAS DEVELOPED A 130 μ m SiC (C-CORE) FILAMENT

E 50 - 60 Msi

σ 500 ksi

ρ 3.2. g/cc

ADVANTAGES: EXCELLENT MECHANICAL PROPERTY

DISADVANTAGES: DIAMETER AND DENSITY

RECOMMENDATIONS: EVALUATE IN HYBRID
DEVELOP SMALL DIAMETER TOW

B₄C YARN

A CONTINUOUS FILAMENT YARN HAS BEEN REPORTED

E 40 - 55 Msi

σ 300 - 400 ksi

ρ 2.28 g/cc

YARN 720 ENDS, 9 μ m DIAMETER

ADVANTAGES:

SIMILAR IN PROPERTIES TO GRAPHITE

DISADVANTAGES:

LAB PROCESS DEFINED BUT WILL REQUIRE
2 - 3 YR. SCALE-UP.
COST GRAPHITE

RECOMMENDATION:

CARRY OUT COST ANALYSIS

RECOMMENDATIONS

CONTINUE PLANS WITH

- o INORGANIC COATINGS
- o ORGANOMETALLIC COATINGS
- o BN FIBERS

INITIATE PROGRAMS ON

- o HIGH CHAR YIELD ORGANIC COATINGS
- o HYBRID OF HIGH MODULUS ORGANICS
WITH B (CARBON CONE), SiC (CARBON CORE)
 Al_2O_3 (FP)
- o B_4C YARN SCALE-UP
- o LOW COST SiC TOW

ORGANIC FIBERS AND HYBRID COMPOSITES

ASHOK DHRINGRA
E.I. DUPONT

MARCH 23, 1978

EXPERIMENTAL HIGH MODULUS ORGANIC FIBERS

Properties of certain experimental organic fibers exhibiting very high strengths and high moduli will be discussed. These have tensile strengths ranging from 400 Kpsi to 600 Kpsi and tensile moduli ranging from 25 to 30 x 10⁶ psi. Fiber densities are low and range from 1.22 to 1.46 g/cc. These fibers should be of interest in composites provided an effective transfer of their properties into laminates can be achieved.

FP/KEVLAR® AND GRAPHITE/KEVLAR® HYBRID COMPOSITES

An experimental inorganic aluminum oxide fiber designated Fiber FP is currently under development in the Du Pont Company. This fiber is characterized by high modulus, outstanding compressive strength, hydrolytic and chemical stability and nonconductivity. Combining Fiber FP or graphite with Kevlar® aramid fiber produces hybrid composite structures having significantly improved combination of properties not attainable with single fibers. The properties of FP/epoxy, FP/polyimide, FP/Kevlar®/epoxy hybrid and Graphite/Kevlar®/epoxy hybrid will be discussed.

POSSIBLE SOLUTIONS

NEW FIBERS

1. HIGHER MODULUS ORGANIC FIBERS (BEYOND KEVLAR®)
2. HIGHER TENSILE STRENGTH FP FIBER
3. LOWER DENSITY INORGANIC FIBER (MODIFIED FP)
 - MODULUS 40MM PSI
 - STRENGTH 300 KPSI
 - ELONGATION 0.8%

APPROACH

HYBRID COMPOSITES

EXPERIMENTAL HIGH MODULUS ORGANIC FIBERS

	Density (lb/in ³)	Tensile Strength (Kpsi)	Tensile Modulus (10 ⁶ psi)	Specific Strength (10 ⁶ in)	Specific Modulus (10 ⁸ in)	How Tested
Composition A	.052	341	25.8	6.6	5.0	10 in. yarn
Composition B	.052	336	27.4	6.5	5.3	10 in. yarn
Composition C	.052	408	29.6	7.8	5.7	10 in. yarn
Composition D	.052	450	28.8	8.7	5.5	10 in. yarn
Composition E	.044	664	20.5	15.1	4.7	10 in. yarn in resin

COMP.
○ E

SPECIFIC TENSILE STRENGTH
AND
SPECIFIC TENSILE MODULUS
OF REINFORCING FIBERS

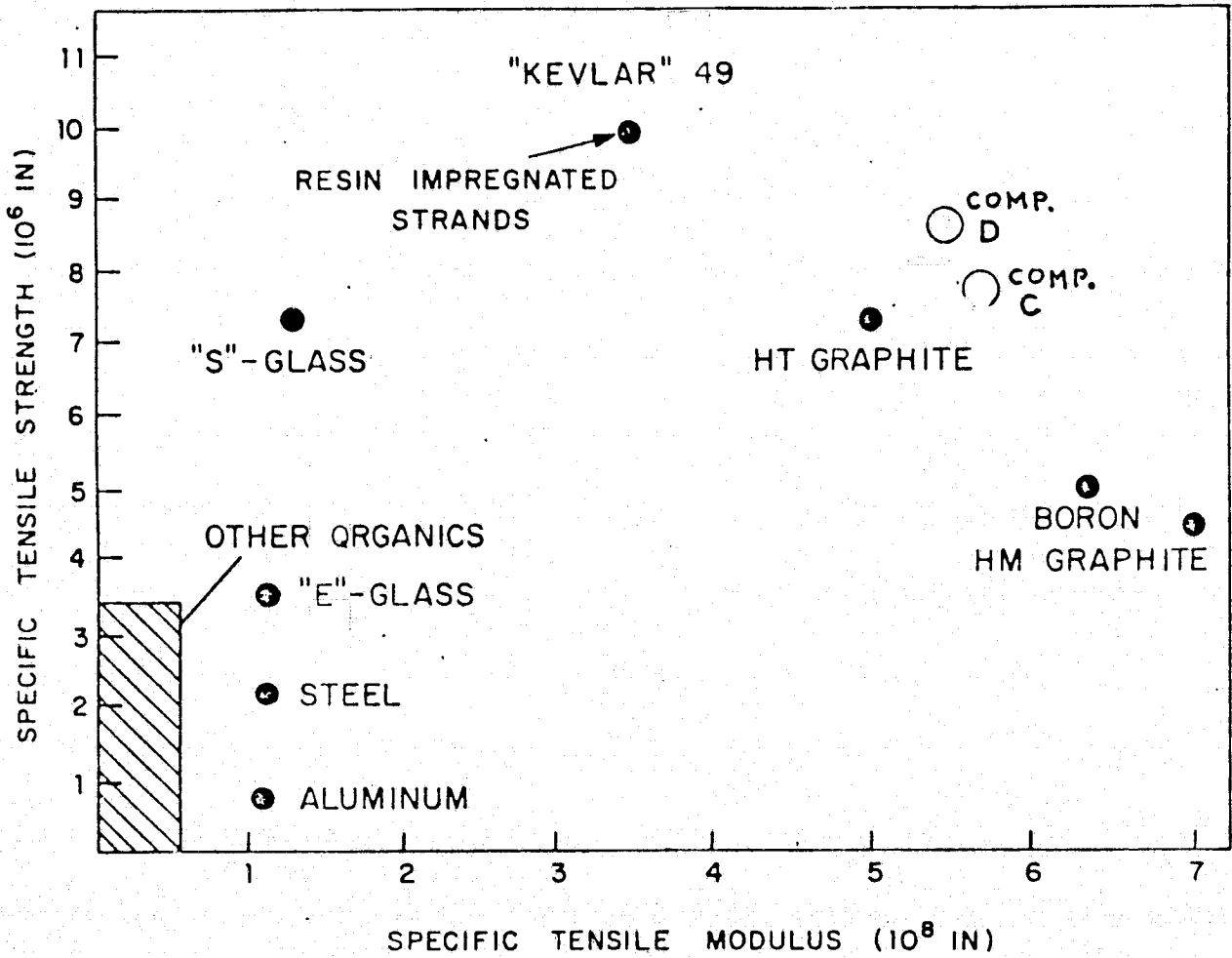

STRESS - STRAIN BEHAVIOR OF REINFORCING FIBERS

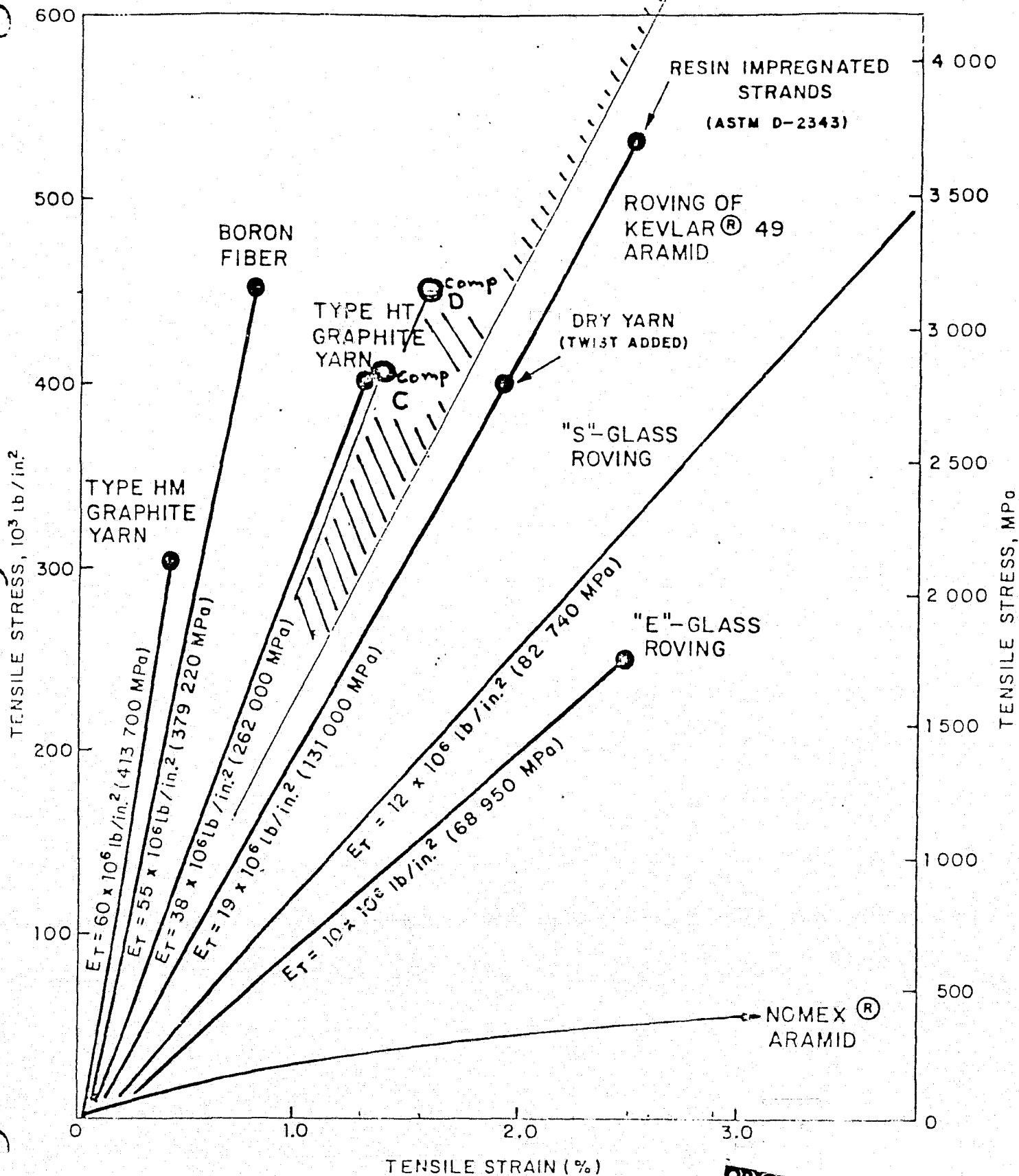

ASTM D2343-67 RESIN IMPREGNATED
STRAND TEST

**ORIGINAL PAGE IS
OF POOR QUALITY**

MECHANICAL PROPERTY COMPARISON
FP/KEVLAR® 49/EPOXY -VS- KEVLAR® 49/EPOXY

<u>PROPERTY</u>	<u>KEVLAR®/EPOXY (60/40)</u>	<u>FP/KEVLAR®/EPOXY (30/30/40)</u>	<u>CHANGE</u>
COMPRESSIVE MODULUS, MPsi	11.5	21	1.8X
COMPRESSIVE STRENGTH, Kpsi	40	150	3.75X
TENSILE MODULUS, MPsi	14	20	1.4X
TENSILE STRENGTH, Kpsi	193	148	-23%

- COMBINING FP WITH KEVLAR® GREATLY IMPROVES STIFFNESS AND COMPRESSIVE STRENGTH

TABLE II

PROPERTIES OF UNIDIRECTIONAL "THORNEL" 300, "KEVLAR" 49
AND HYBRID COMPOSITES - NOMINAL FIBER VOLUME FRACTION = 0.60

Percentages of "Thornel" 300/ "Kevlar" 49 Fibers	Specific* Gravity	Tension		Compression		Flexure		Short Beam Shear Stress (ksi)	Prepreg Cost \$/lb
		Modulus (10 ⁶ psi)	Ultimate Stress (ksi)	Stress at 0.02% Offset (ksi)	Ultimate Stress (ksi)	Stress at 0.02% Offset (ksi)	Ultimate Stress (ksi)		
100/0	1.60	21.1	227	98.4	146	233	233	13.2	60
75/25	1.56	17.4	186	68.8	136	181	197	11.0	48
50/50	1.51	15.7	176	59.9	99.8	120	160	8.1	35
0/100	1.35	11.2	183	26.4	41.5	49.2	91.9	7.1	13

*Data supplied by Fiberite

TABLE III

MECHANICAL PROPERTIES OF "KEVLAR" 49-"THORNEL" 300
HYBRID BALANCED FABRIC COMPOSITES

Tension and Compression Data
Normalized to 65% Fiber Volume Fraction

Ratio of "Kevlar" 49-to- "Thornel" 300	Resin	Specific Gravity	Modulus (10^6 psi)	Tensile Strength (10^3 psi)	Compressive Stress		Short Beam Shear Strength (10^3 psi)
					At 0.02% Offset (10^3 psi)	Ultimate (10^3 psi)	
100/0	Fiberite 934	1.40	5.2	79	11.0	22	3.8
50/50	"	1.49	7.0	58	23	33	4.2
25/75	"	1.57	8.3	63	32	46	4.7
0/100	"	1.60	8.7	63	47	81	5.8
50/50	BP-907	1.44	6.7	60	24	42	7.0

TABLE VI

MECHANICAL PROPERTIES OF "KEVLAR" 49-"THORNEL" 300
HYBRID UNIDIRECTIONAL FABRIC COMPOSITES

Tension and Compression Data
Normalized to 65% Fiber Volume Fraction

<u>Ratio of "Kevlar" 49-to- "Thornel" 300</u>	<u>Resin</u>	<u>Specific Gravity</u>	<u>Modulus (10⁶ psi)</u>	<u>Tensile Strength (10³ psi)</u>	<u>Compressive Stress</u>		<u>Short Beam Shear Strength (10³ psi)</u>
					<u>At 0.02% Offset (10³ psi)</u>	<u>Ultimate (10³ psi)</u>	
50/50	Fiberite 934	1.44	12.6	103	32	52	7.9
50/50	BP-907	1.40	11.3	104	44	56	8.1

TABLE V

NOTCH SENSITIVITY OF [0/90] AS GRAPHITE-"KEVLAR" 49 HYBRID COMPOSITES

Reinforcement	Modulus (10^6 psi)	Thick. (in.)	Nominal Crack Length (in.)	Stress at Failure		Fracture Toughness K_c (ksi-in ^{1/2})	Stress Concentration Factor K
				Gross σ_g (ksi)	Net σ_n (ksi)		
<u>AS Graphite (Tape)</u> 8-Ply	7.67	0.048	0	75.8	75.8	--	--
	--	0.048	0.25	14.88	19.88	9.37	3.82
12-Ply	7.87	0.072	0	78.5	78.5	--	--
	--	0.072	0.25	15.31	20.5	9.66	3.82
<u>"Kevlar" 49</u> (Style 120 Fabric)	4.17	0.030	0	72.9	72.9	--	--
	--	0.030	0.25	25.2	34.3	16.16	2.13
<u>Hybrid (8 Plies</u> of Graphite Tape + 4 Plies of "Kevlar" 49 Fabric)	6.32	0.078	0	66.5	66.5	--	--
	--	0.078	0.25	20.2	27.0	12.75	2.46

MECHANICAL PROPERTY COMPARISON OF HYBRID COMPOSITES

PROPERTY	KEVLAR®/T _H 300/EPOXY (30/30/40)	FP/KEVLAR®/EPOXY (30/30/40)	KEVLAR®/EPOXY (60/40)	T _H 300/EPOXY (60/40)
TENSILE MODULUS, Mpsi	16	20	11	21
TENSILE STRENGTH, Kpsi	176	148	183	227
198 COMPRESSIVE MODULUS, Mpsi	16	21	11	21
COMPRESSIVE STRENGTH, Kpsi	100	150	40	146
FLEXURE STRENGTH, Kpsi	160	180	92	233
SHORT BEAM SHEAR, Kpsi	8.1	9.1	7.1	13.2
DENSITY, g/cm ³ (LB/IN ³)	1.51 .055	1.95 .070	1.35 .049	1.60 .058

SPECIFIC PROPERTY COMPARISON OF HYBRID COMPOSITES

SPECIFIC PROPERTY	KEVLAR®/T _H 300/EPOXY (30/30/40)	FP/KEVLAR®/EPOXY (30/30/40)	KEVLAR®/EPOXY (60/40)	T _H 300/EPOXY (60/40)
SPECIFIC TENSILE MODULUS, 10 ⁸ IN	2.91	2.86	2.24	3.62
SPECIFIC TENSILE STRENGTH, 10 ⁶ IN	3.2	2.11	3.73	3.91
SPECIFIC COMPRESSIVE MODULUS, 10 ⁸ IN	2.91	3.0	2.24	3.62
SPECIFIC COMPRESSIVE STRENGTH, 10 ⁶ IN	1.82	2.14	0.82	2.52

FLEXURAL MODULUS vs TEMPERATURE
NR-150 POLYIMIDE COMPOSITES

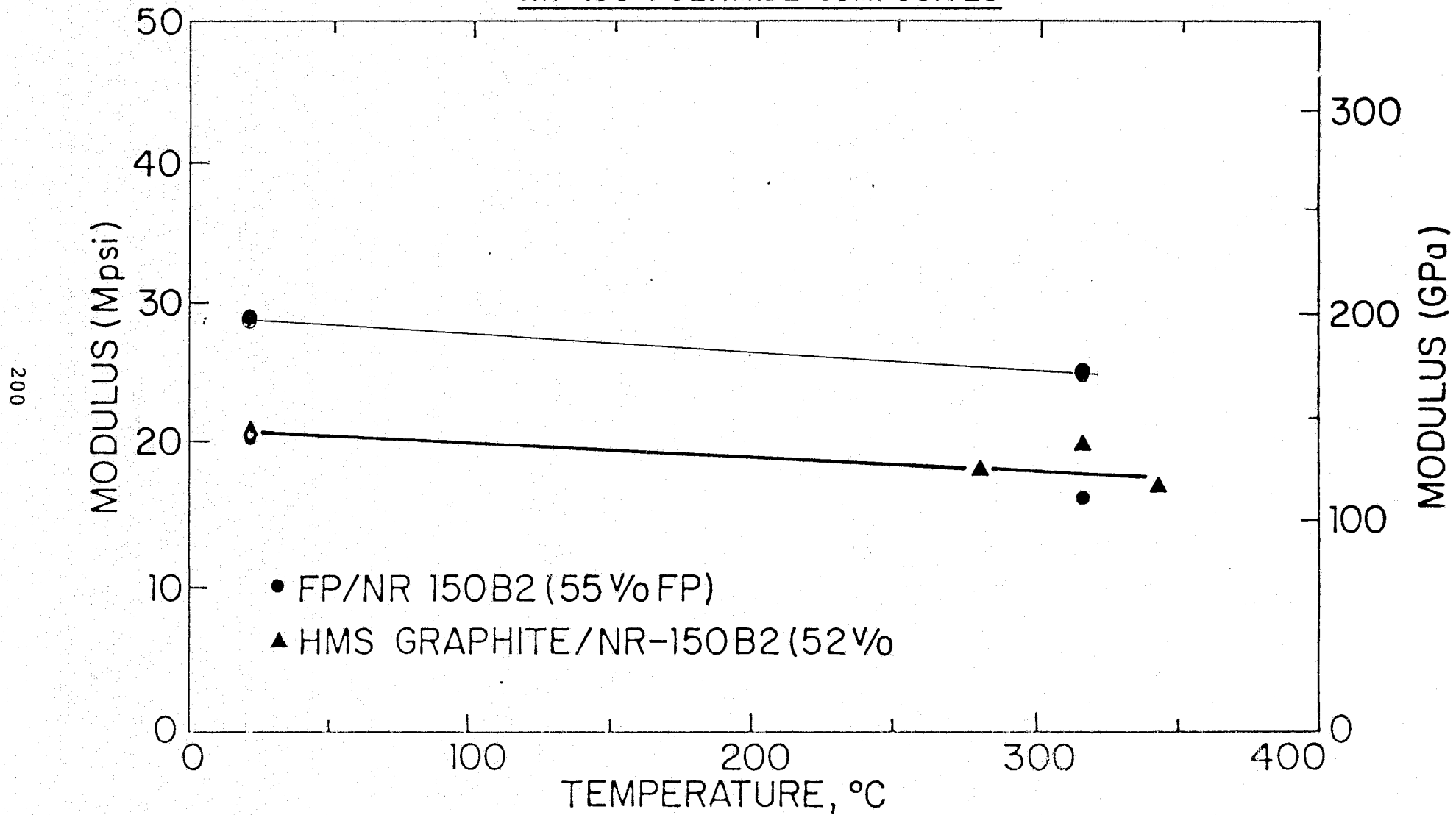

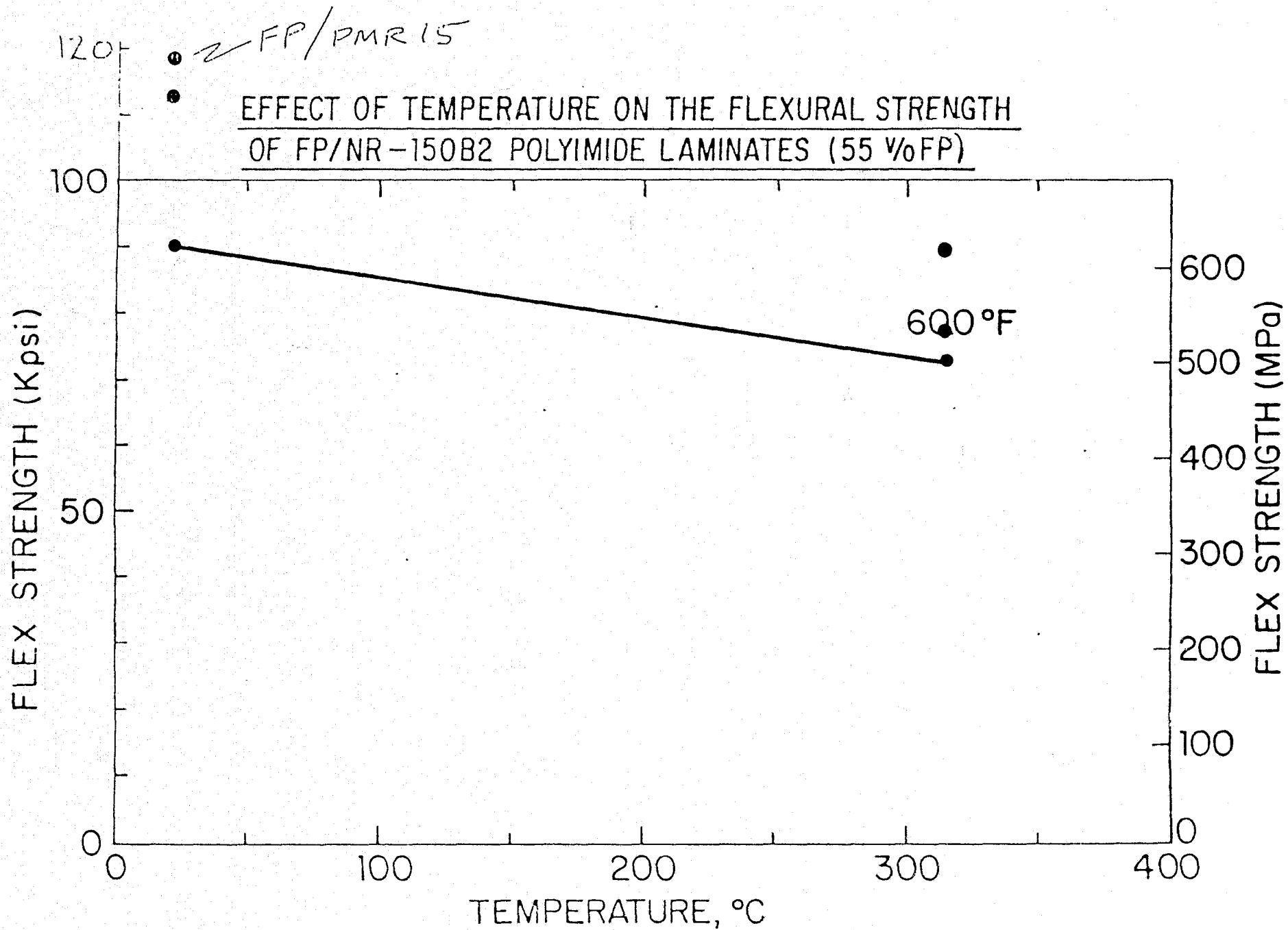

EFFECT OF TEMPERATURE ON THE SHORT BEAM SHEAR STRENGTH OF
F.P. ALUMINA / NR-150B2 POLYIMIDE LAMINATES ($V_f = 0.55$)

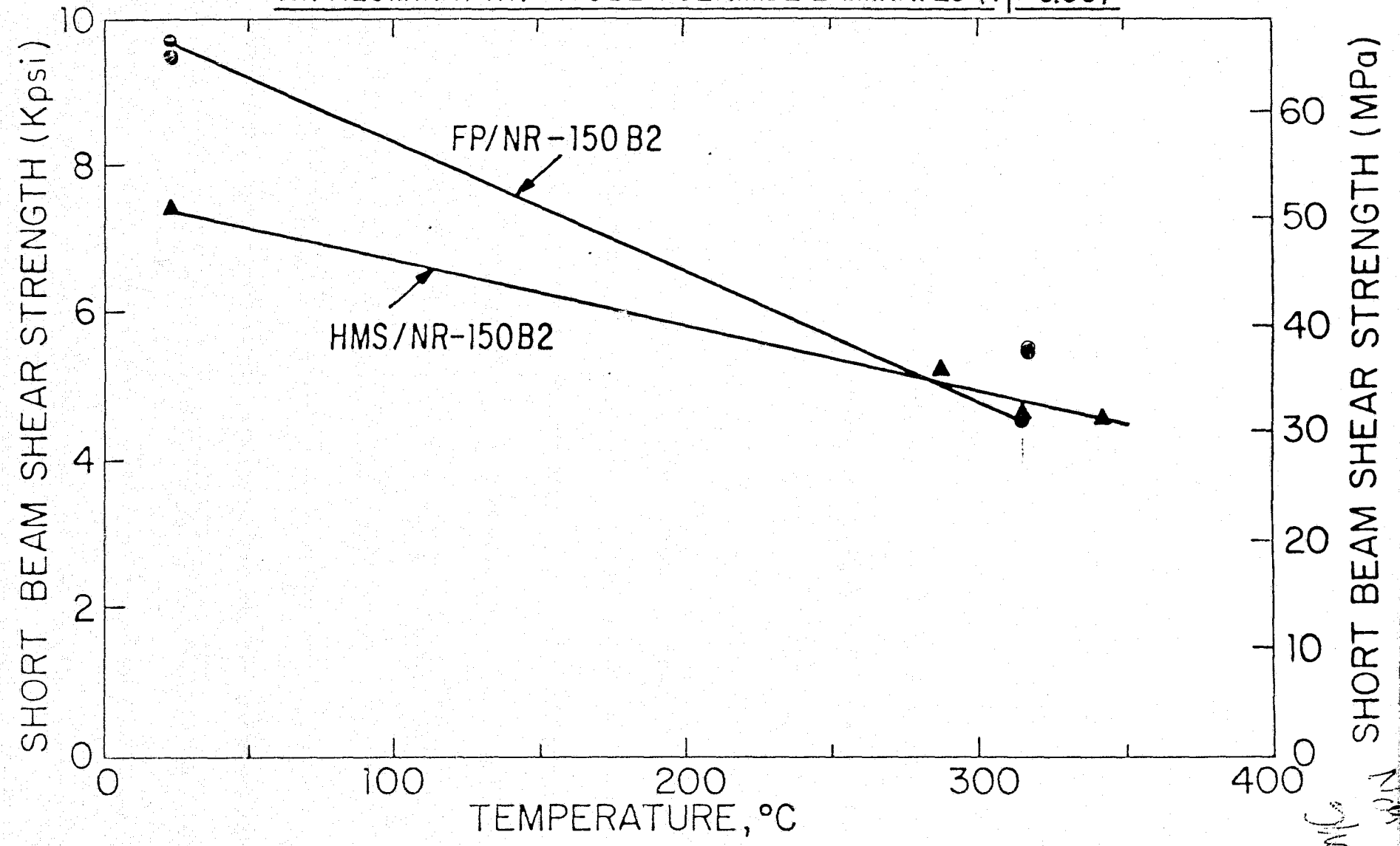

202

Handwritten notes and a signature in the bottom right corner.

BORON NITRIDE FIBERS
ROBERT S. HAMILTON
THE CARBORUNDUM COMPANY

MARCH 23, 1978

Dielectric Properties - The dielectric properties of boron nitride composites using boron nitride fiber are displayed in Table 3.

CHEMICAL PROPERTIES

Acid-Base Stability - Boron nitride is very stable to acidic and basic medium. Table 4 compares the weight loss upon refluxing for boron nitride fiber, carbon fiber and Pyrex fibers. Also, included in Table 4 is the action of room temperature hydrofluoric acid on these fibers. Boron nitride fibers shows 0.1% weight loss after 75 hours exposure to 100°C water. A loss of 0.8% after 1 hour of 700°C steam. Boron nitride fibers are also stable in melts of silicon, copper, cryolite, sodium chloride, lithium chloride, potassium chloride mixtures and molten cast iron and aluminum.

PREPARATION OF BORON NITRIDE FIBER

Boron nitride fiber is currently prepared by the method of Economy and Anderson as patented in 1972 (U.S. #3,668,059).

The three step process:

1. Fiberization of a boric oxide melt.
2. Nitriding of the boric oxide fiber.
3. Orientation/stabilization of the nitrated boric oxide fiber

where Step 1 uses commercially similar fiber glass drawing techniques. Step 2 is a unique gas phase - solid phase chemical conversion step and Step 3 is similar to processing used to produce high performance graphite fiber.

Process Chemistry - The chemistry of Step 2 and 3 can be expressed as:

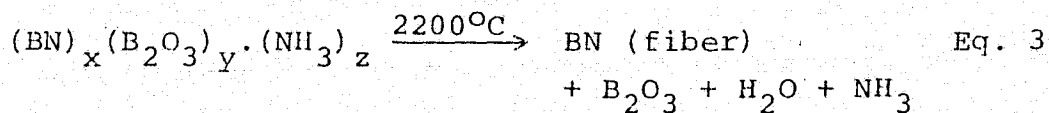
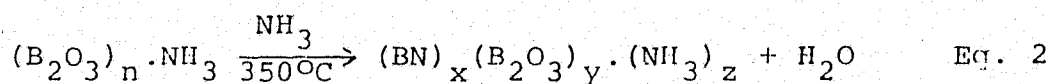
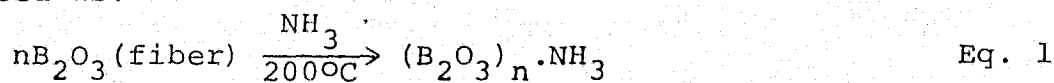

with Equation 1 and 2 describing the gas phase - solid phase chemical nitriding of boric oxide fiber of Step 2 and Equation 3 describing the Purification/Stabilization process of Step 3. The reactions of Equation 1, diffusion of ammonia into the solid boric oxide fiber and the diffusion of H₂O

BN

ORIGINAL PAGE IS
OF POOR QUALITYTest Speed .02 in/min.
Gage Length 1.00 in.

<u>Diameter (Microns)</u>	<u>Stress (psi)</u>	<u>Modulus (psi)</u>
4.03	106736	31158036
4.48	145736	30398249
4.10	170063	22093583
3.75	162268	46708458
5.37	65131	26168747
3.30	337774	50896127
3.36	76766	24459884
3.94	103412	32176816
3.54	135765	26929805
3.98	109705	27147841
4.87	62571	26453153
3.56	175463	43466871
3.63	99009	26484057
3.30	116473	32446280
3.46	176578	41304888
3.96	106305	33588282
3.30	91515	53704189
3.52	99444	30968947
4.25	64992	23753659
3.72	75579	25623728
4.22	34529	11852551
3.92	86949	28640527
Mean	118307	31655667
Std. Dev.	62810	9981718

Table 5. Boron Nitride Fiber Tensile Test
(Fiber Stretched 30%)

ELECTRODIC COATINGS

R. V. SUBRAMANIAN

WASHINGTON STATE UNIVERSITY

MARCH 23, 1978

ORIGINAL PAGE IS
OF POOR QUALITY

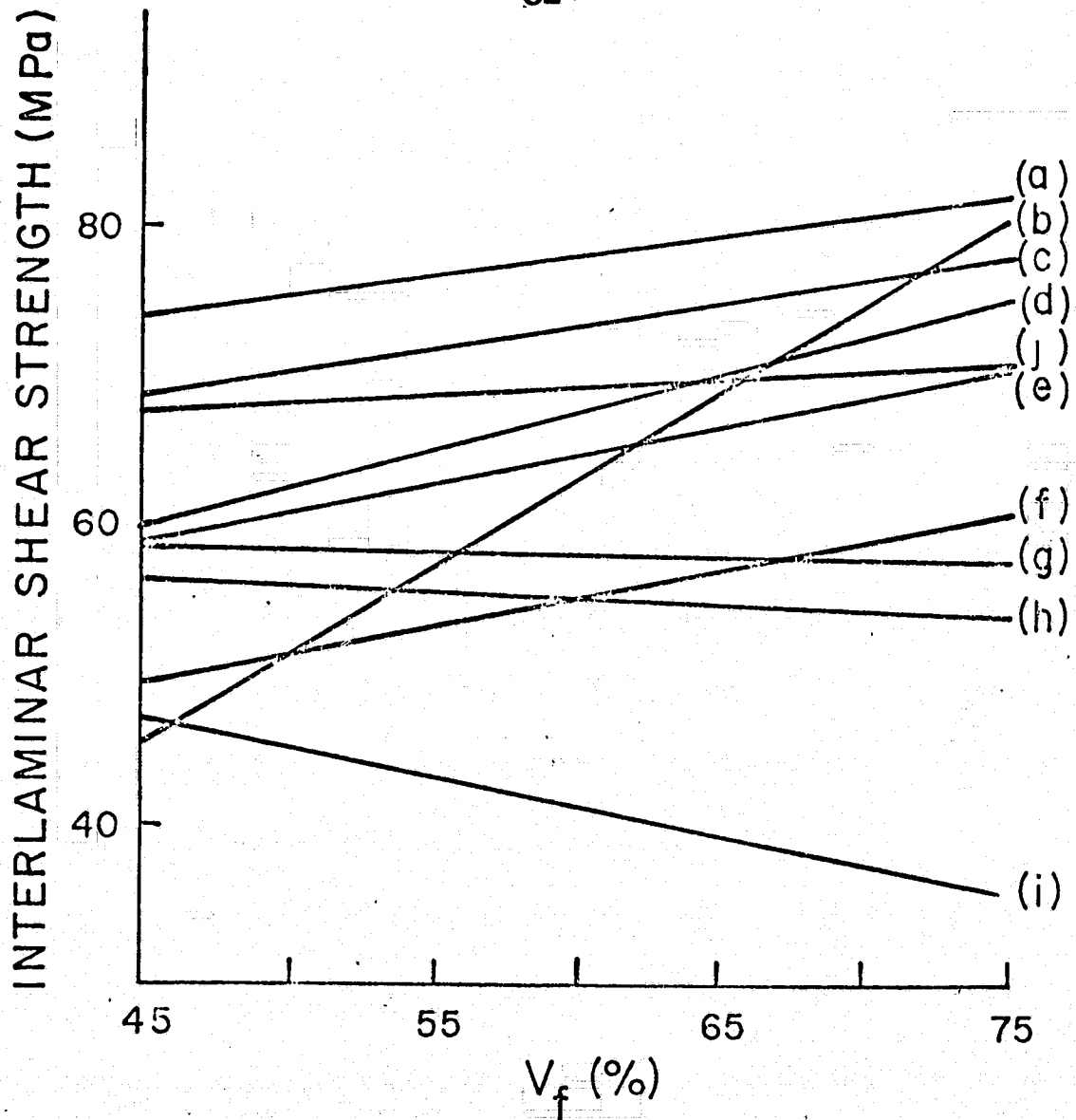

FIGURE 2

Interlaminar Shear of Composites Prepared from Fibers Coated with (a) Acrylic Acid (b) PFAZ 300 (c) DAA 2.5 seconds (d) Styrene (e) MMA (f) Styrene/Acrylonitrile (g) ϵ -Caprolactam (h) EPON 828/Phthalic Anhydride (i) VTBN (j) and Untreated Hercules AU Carbon Fiber

Submittal

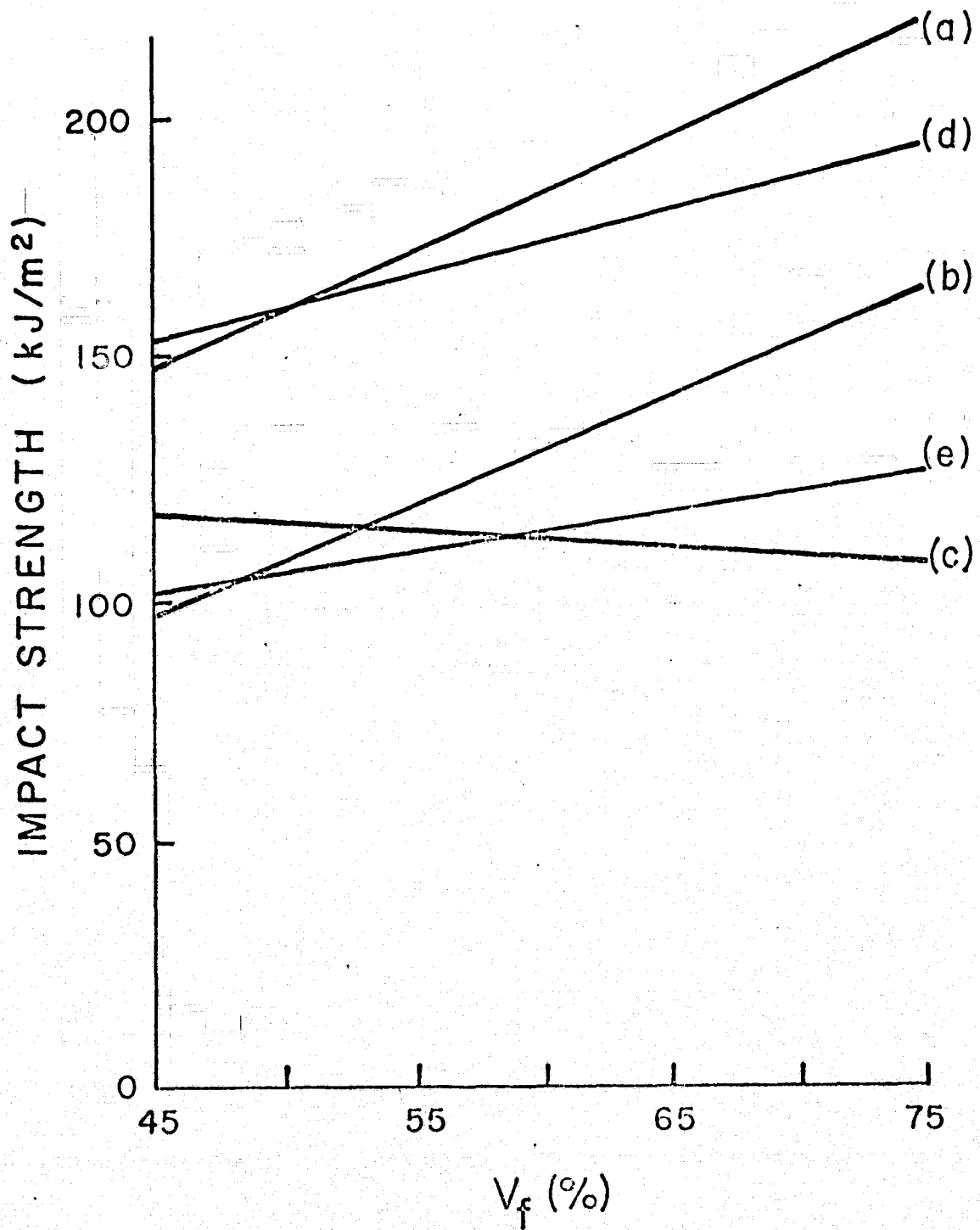
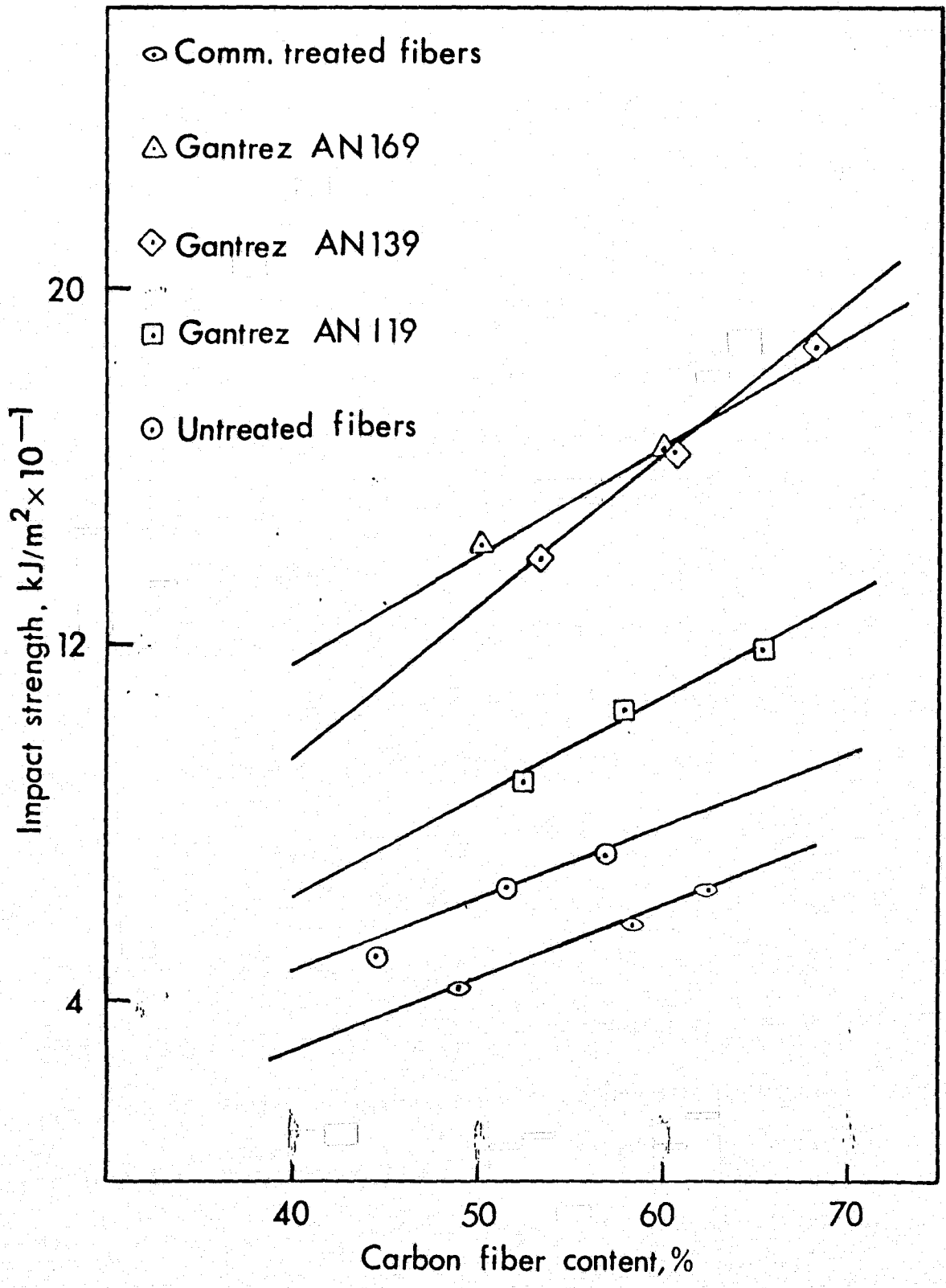
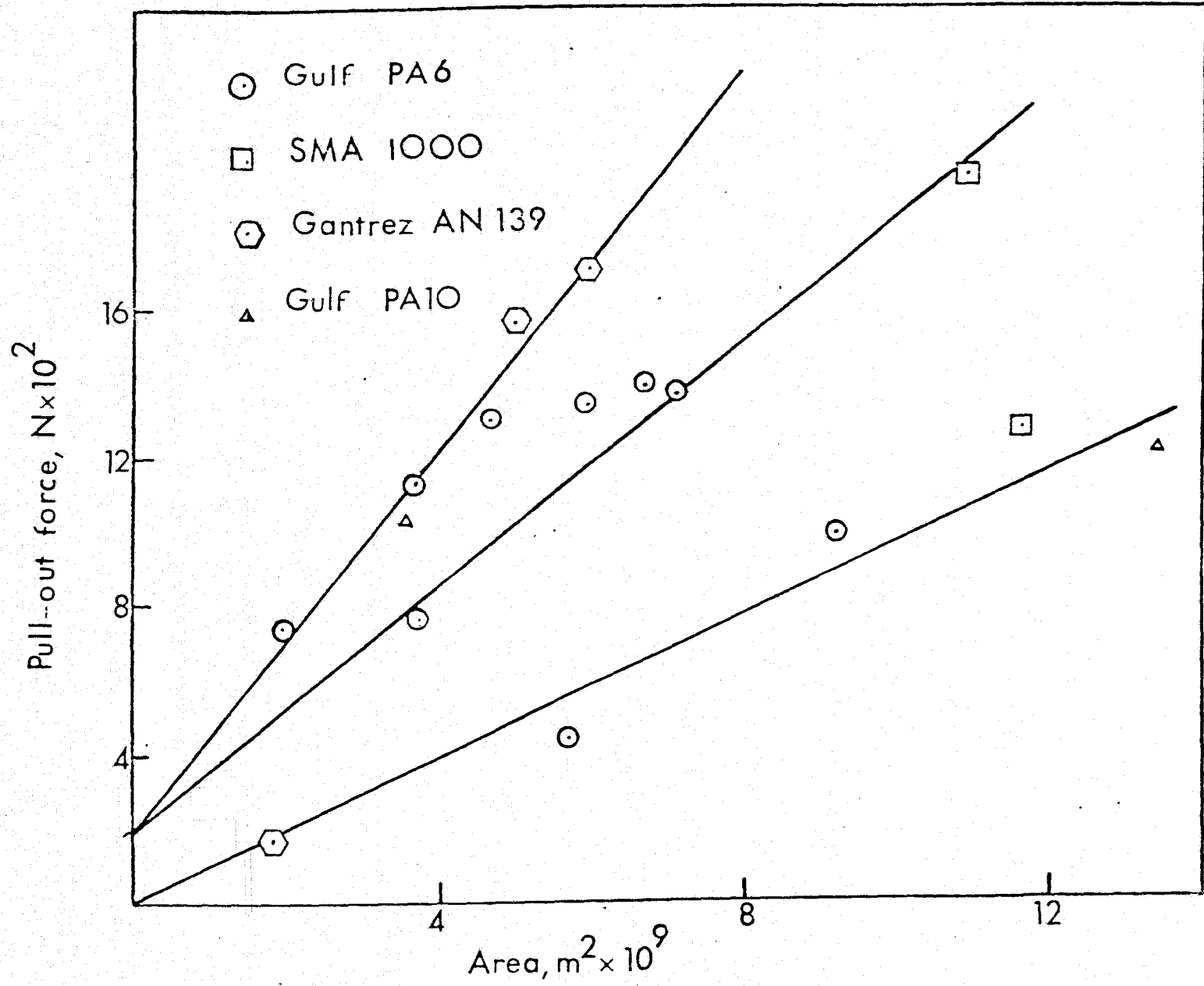

FIGURE 3

Impact Strength of Composites Prepared from Fibers Coated with (a) PFAZ 300 (b) DAA 10 Seconds (c) DAA 2.5 Seconds (d) Hercules Au and (e) Hercules AS Carbon Fiber



Sub. by ...



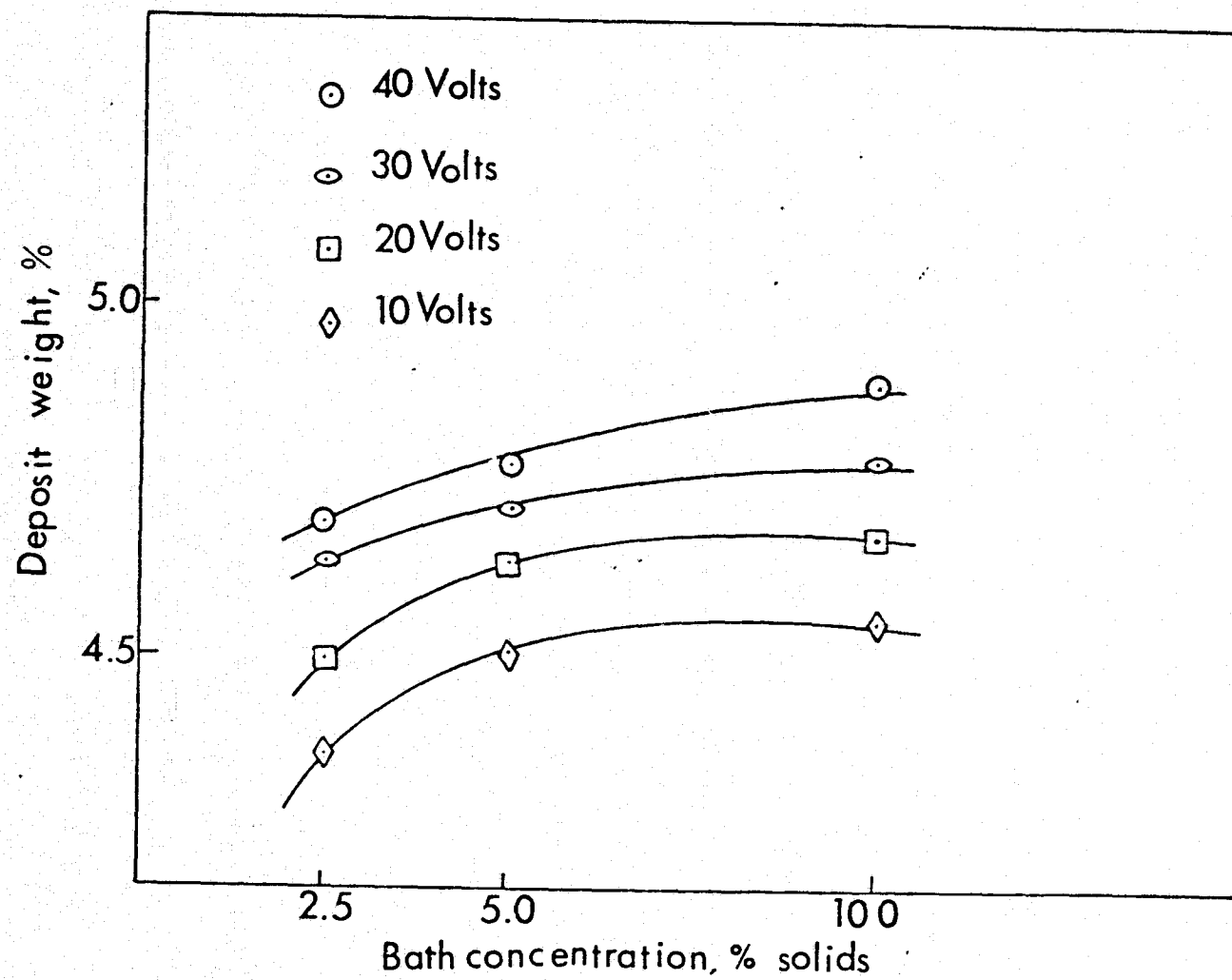

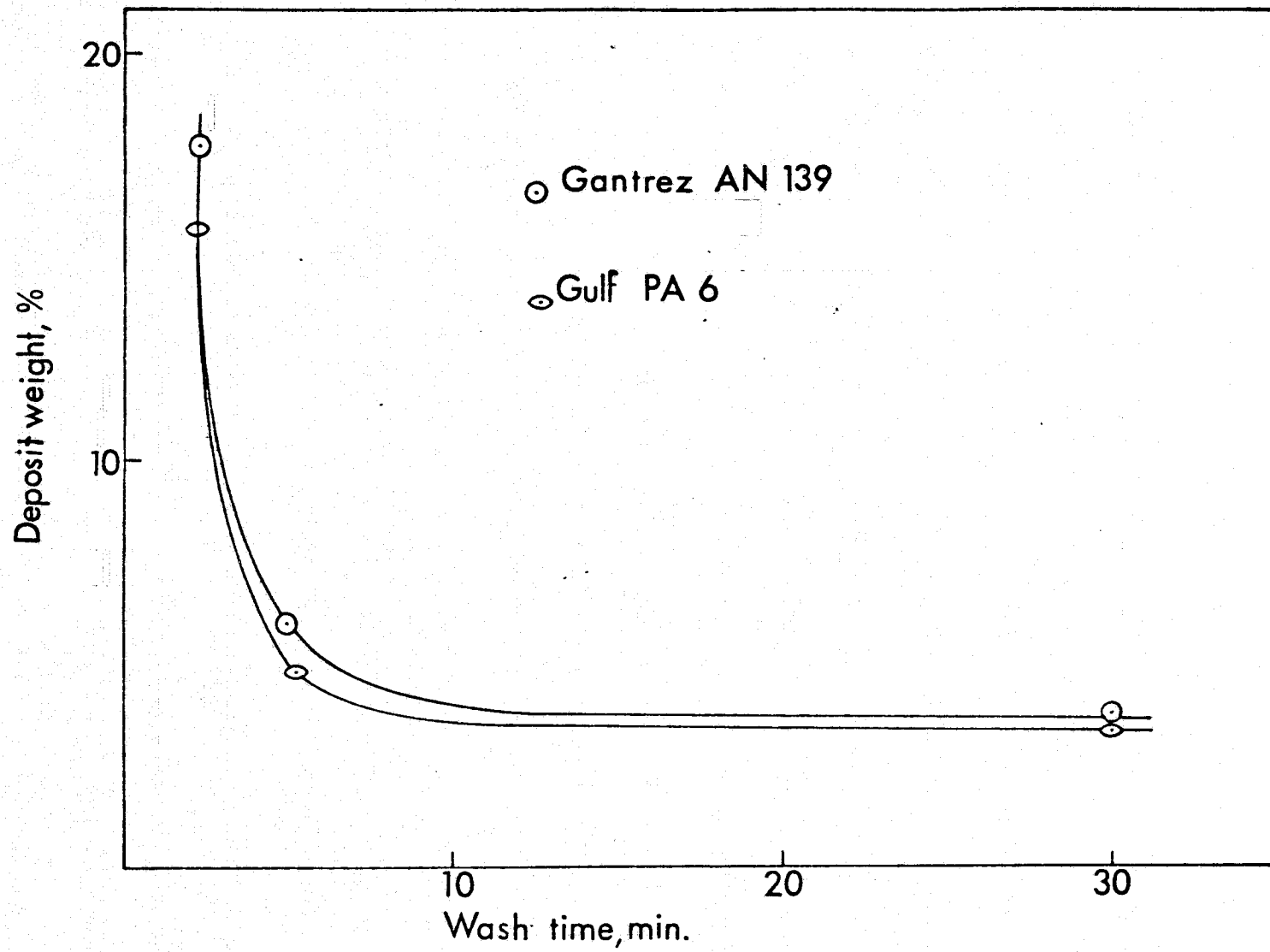

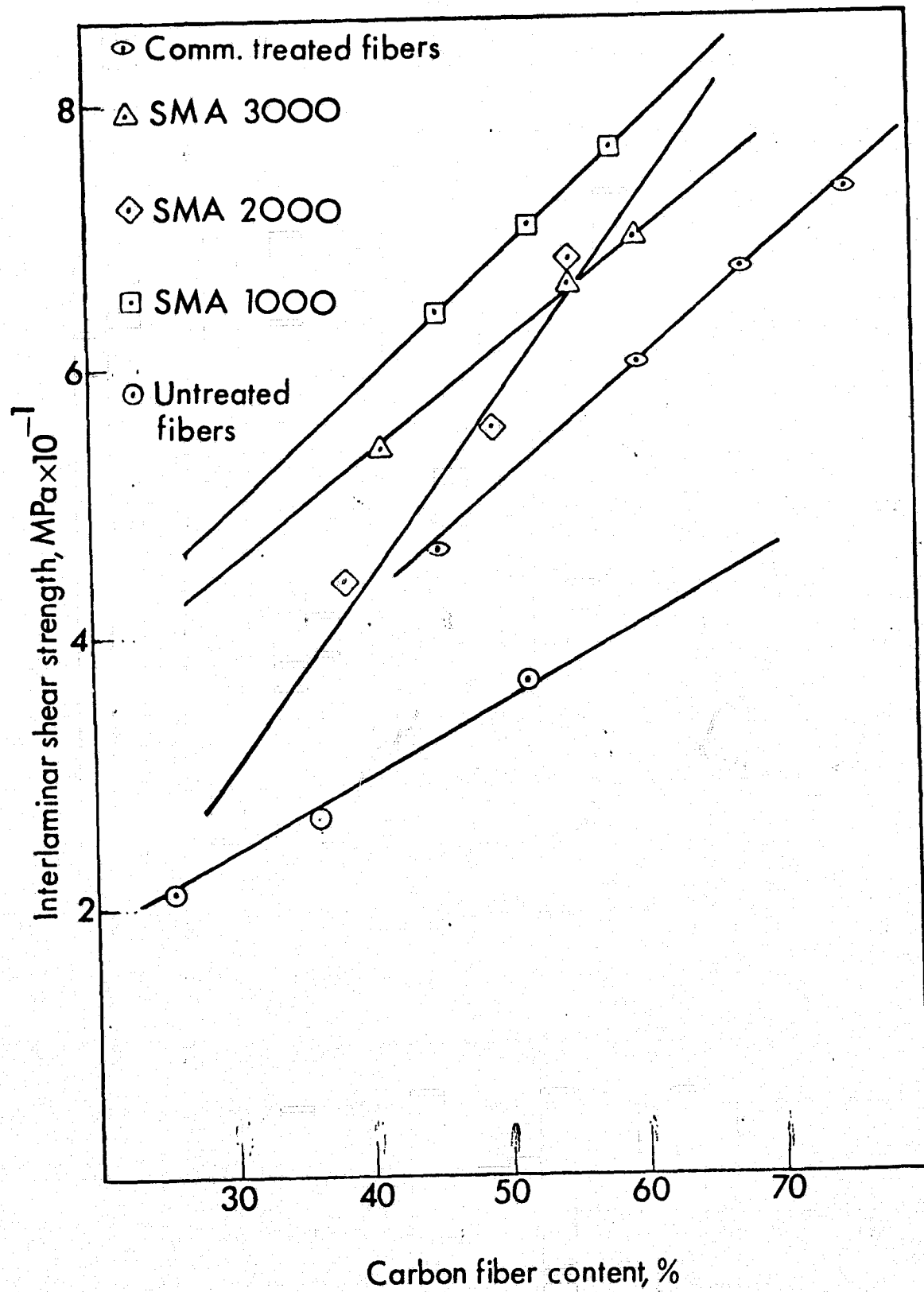

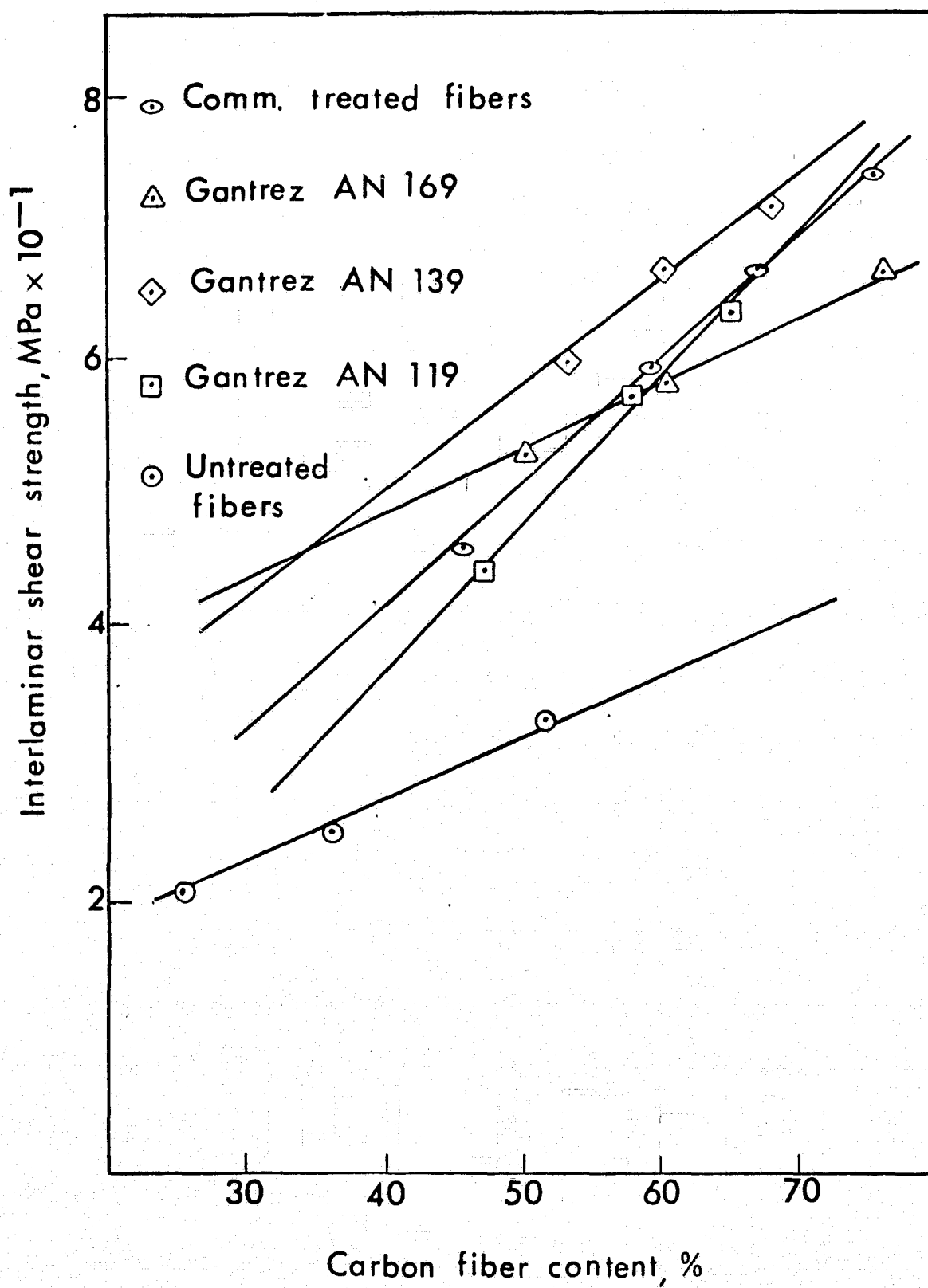

SOME IDEAS AND PRELIMINARY RESULTS TO ALLEVIATE ELECTRICAL PROBLEMS OF CARBON FIBER COMPOSITES

Kumar Ramohalli

**WARREN DOWLER, ROBERT GAULDIN, JOHN QUINN, FRED TERVET
DONALD UDLOCK, GIULIO VARSI, LIEN YANG**



**SOLID PROPULSION AND ENVIRONMENTAL SYSTEMS SECTION
JET PROPULSION LABORATORY
PASADENA, CALIFORNIA**

**WORKSHOP ON CARBON FIBERS, N.A.S.A. LANGLEY RESEARCH CENTER
HAMPTON, VIRGINIA
23, 24 MARCH 1978**

215

ORIGINAL PAGE IS
OF POOR QUALITY



INTRODUCTION

- CARBON FIBER COMPOSITES HAVE RELEASED FIBERS
WHEN BURNED WITH AGITATION
 - FIBERS HAVE CAUSED ELECTRICAL PROBLEMS
 - ULTIMATE AIM: PREVENT RELEASE OF CONDUCTING FIBERS
IMMEDIATE AIM: GENERATE IDEAS AND RESULTS SHOWING PROMISE
 - THIS PRESENTATION
 - BASIC IDEAS
 - TEST METHODS
 - EXPERIMENTAL RESULTS
 - SUMMARY AND FUTURE WORK
- } NASA TM 78652
} DOC NEWS
} ITA-78-13
} TIME 13 MARCH

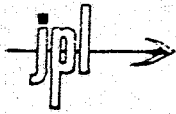

BASIC APPROACH

- PREVENT RELEASE OF CONDUCTING FIBERS
 - BEFORE USE IN RESIN
 - COAT FIBERS WITH DIELECTRIC
 - COAT FIBERS WITH CATALYST FOR GASIFICATION (C, CO, CO₂)
 - COAT FIBERS WITH CHEMICALS TO HOLD THEM IN MATRIX (CROSSLINK, CHAR)

- TEST METHODS
 - AROUND A BURNING COMPOSITE, FOR SPECIFIED TIME
 - COUNT NUMBER OF FIBERS
 - COUNT NUMBER OF SHORTS IN TYPICAL CIRCUIT

- EXPERIMENTS
 - BURN TESTS, TGA STUDIES, SEM, EDAX DATA
 - TEST CIRCUITS



CATALYSIS

- SODIUM IS SHOWN TO CATALYSE GASIFICATION (REF WENDT et. al.)
- PREFER
 - SMALL AMOUNTS ON FIBER
 - SHOULD NOT AFFECT SERVICE LIFE
- CANDIDATES SO FAR:
 - NaNO_3 , LiNO_3 , KMnO_4 , PPQ, FeAA, COBALT NAPHTHENATE
- TGA STUDIES:
 - IN AIR AND NITROGEN (ALSO ARGON AS A CHECK IN FEW CASES)
 - THORNEL-300 (PLAIN, AND COATED BY DIP IN SOLUTION)
 - $20^\circ\text{C}/\text{MIN}$ TO 1000°C
 - REPRODUCIBILITY CHECKED (5% MAXIMUM ERROR)
- PPQ APPEARS PROMISING ON THORNEL-300 (IN AIR)

• TEMPERATURE $^\circ\text{C}$	WEIGHT LOSS PERCENT	
	PLAIN	COATED WITH PPQ
500	40	7
550	43	23
600	49	56
650	81	100 AT 665°C
700	100	



PREVENTION OF RELEASE FROM MATRIX

- BASIC IDEA

COAT FIBER WITH CHEMICALS THAT DEGRADE AT SURFACE TEMPERATURE OF BURNING COMPOSITE

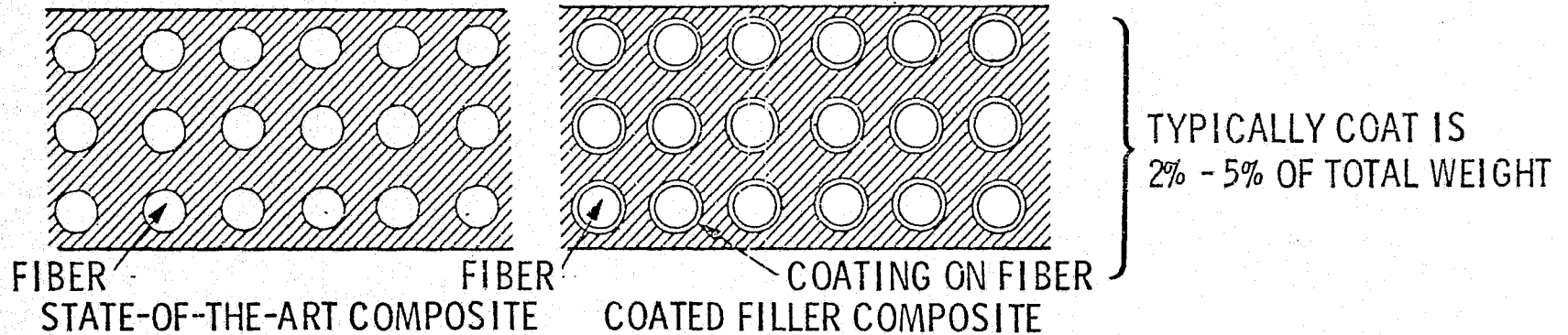

219

- SIMILAR IDEA WORKED WELL IN ANOTHER COMPOSITE SYSTEM (REF. WSS/C1 77-16)

- CANDIDATE CHEMICALS:
 1. (95% ETHYL CELLULOSE + 5% TRICRESYL PHOSPHATE)
 2. COBALT NAPHTENATE
 3. SODIUM SILICATE

- COMPOSITES PREPARED IN

- EPOXY (80% RF-3000 + 20% RF-61)
- POLYIMIDE (NR-150)

{ MOST OF THE TESTS
AIMED AT 30% RESIN AND 70% FIBERS

- TESTS NEEDED FOR PROOF OF CONCEPT



TEST TECHNIQUE

- TIME FOR SHORT CIRCUIT AROUND BURNING COMPOSITE
- INITIAL ARRANGEMENT
COPPER STRIPS ON MASONITE

ORIGINAL PAGE IS
OF POOR QUALITY

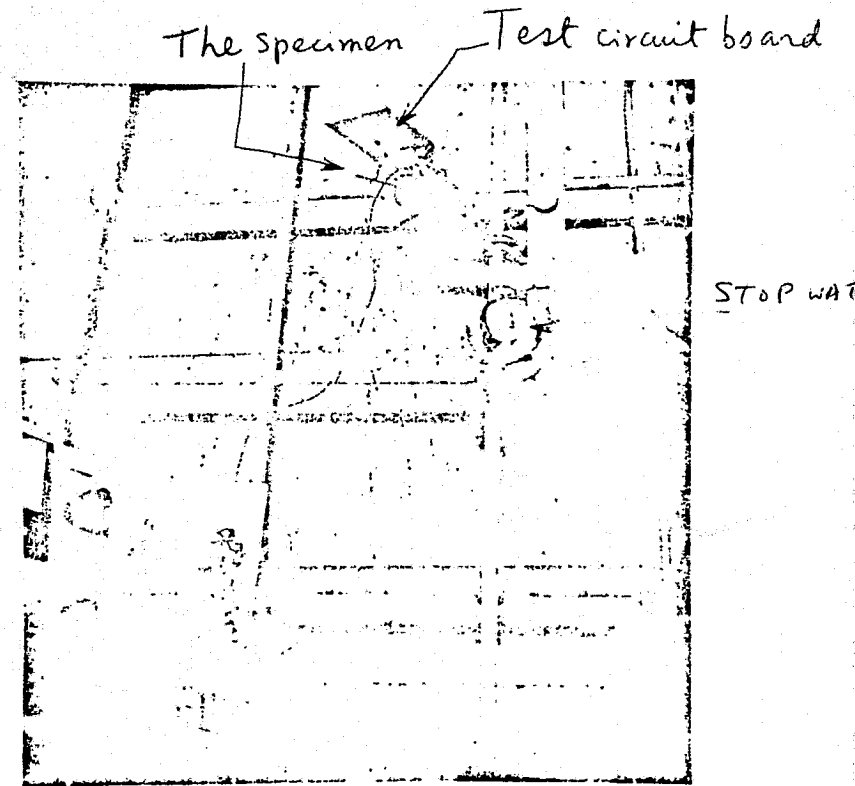
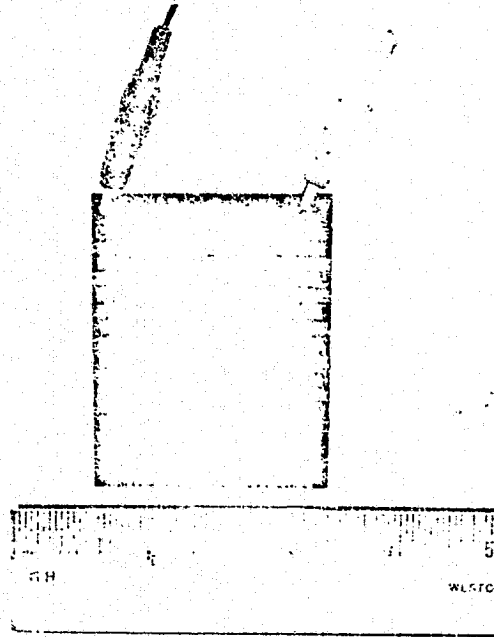

- PROBLEMS WITH BOARD
GAVE SHORTS WITH RESIN ALONE
- IMPROVED DESIGN



PRESENT ARRANGEMENT

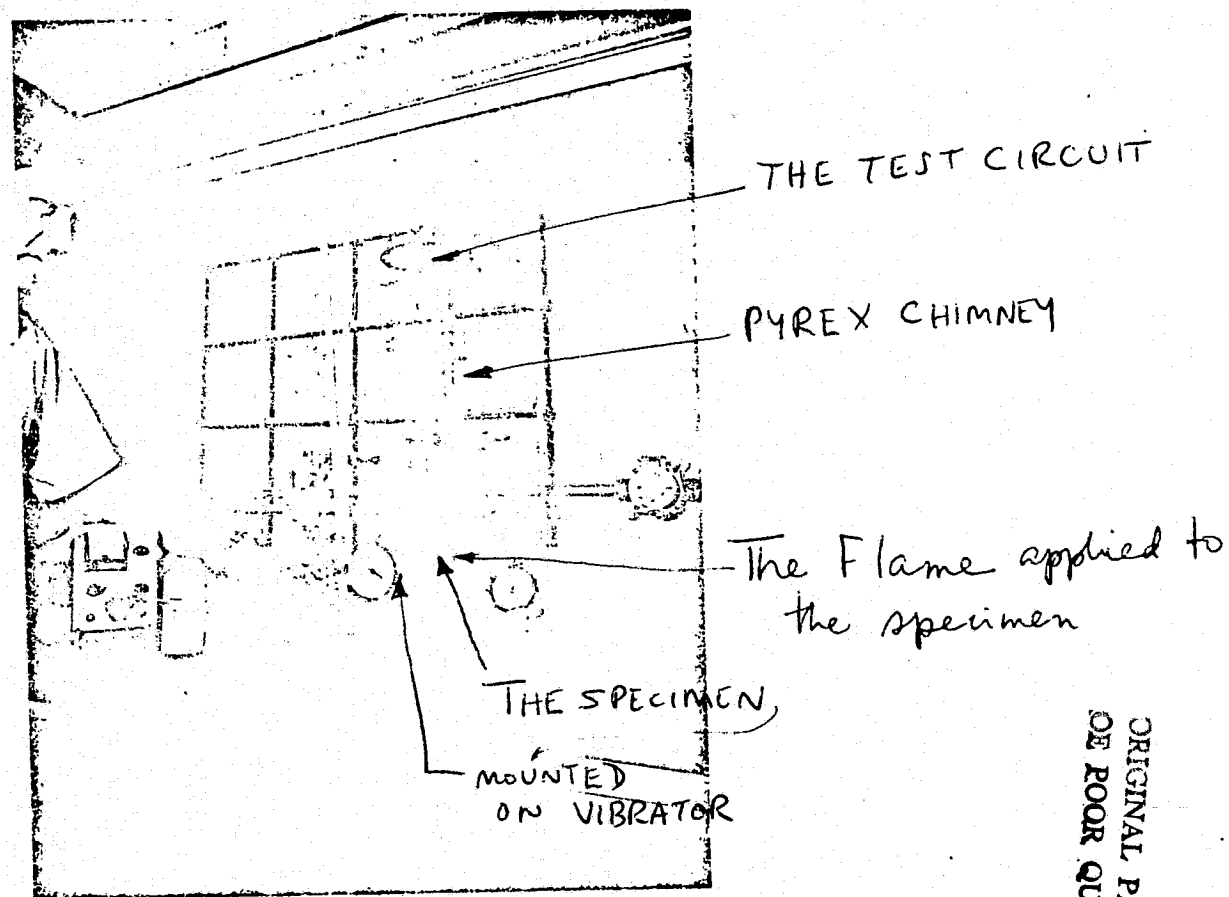

221

ORIGINAL PAGE IS
OF POOR QUALITY



RESULTS

- INITIAL BOARD DESIGN (TIME FOR SHORT)

PLAIN	COATED WITH ECtTCP
55	22
15	21
5	22
12	12
15	22
10	18
10	19
20	21
14	21

- PRESENT SET UP

<u>PLAIN</u>	<u>COATED WITH ECtTCP</u>
12 SEC	18 SEC

- PRELIMINARY TESTS WITH SODIUM SILICATE AS THE COAT:

- NO SHORTS IN WELL OVER A MINUTE
- THE COAT CONTENT WAS ABOUT 20%
- TESTS UNDERWAY TO HAVE SMALL COAT CONTENT

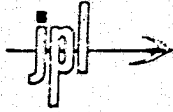

THE LATEST RESULTS

- SODIUM SILICATE APPEARS VERY PROMISING
 - WEIGHT PERCENT COATING IS CAREFULLY CONTROLLED
 - 2%, 5%, 6.93%, 12%, 19.06%
 - ALL OF THEM ARE CAST IN EPOXY (40%/60%-FIBERS/EPOXY)
 - BURNED IN STANDARD SETUP
 - THE 2% COATED SAMPLES GAVE NO SHORTS AT ALL (>90 SECS)
 - RESIN BURNED OFF IN 7 SECONDS
 - FIBERS FELL DOWN IN BUNDLES ...
- WILL BE PURSUED IN DETAIL



SUMMARY AND FUTURE PLANS

- PROBLEM RECOGNIZED
- THREE TASKS
 - CATALYZE GASIFICATION
PPQ SHOWS PROMISE
 - PREVENT RELEASE FROM RESIN CHAR
EC+TCP SHOWS PROMISE
SODIUM SILICATE LOOKS VERY GOOD
 - DEVELOP TEST METHODS
CIRCUIT BOARD APPEARS ADEQUATE FOR RANKING
- FUTURE
 - CONTROL COAT CONTENT AND RESIN CONTENT
 - MORE TESTS (IN NBS SMOKE DENSITY CHAMBER ALSO)
 - MECHANICAL PROPERTIES
 - AGING STUDIES (SERVICE LIFE)
 - THERMOCHEMICAL MODEL

EPOXY RESIN MODIFICATIONS
Dr. James Noland, Chairman

NAME	ORGANIZATION
Norman B. Sunshine	Narmco Materials Inc.
David Crabtree	Northrop Aircraft Co.
C. V. Wittenwyler	Shell Development Co.
Sidney W. Street	U.S. Polymeric (Div. of HITCO)
Richard J. Moulton	HEXCEL
M. J. Katsumoto	Boeing Commercial Airplane, Co.
Robert A. Frigstad	3-M Co.
C. E. Browning	AFML/MBC
James D. Allen	Fiberite Corp.
James Noland	American Cyanamid Co.
Clayton May	Lockheed M&S
Mal Katsumoto	Boeing C/AC
R. J. Tomerlin	Bell Helicopter
William A. Mueller	JPL
R. C. Curley	McDonnell Douglas
R. E. Hoffman	Hercules Inc.
Marvin Rhodes	NASA LaRC
John Parker	NASA Ames
Walter S. Cremens	Lockheed-Georgia
NASA Reporters:	Paul Hergenrother, Norman Johnston, LaRC

ISSUES FOR
EPOXY RESIN MODIFICATIONS
WORKING GROUP

1. What is the most important new resin property that must be designed into any modified epoxy?
2. Can char formers be mixed into an epoxy matrix and still be effective?
3. For each epoxy modification considered:
 - (a) What is the minimum modification that will retard fiber release?
 - (b) Are current synthetic and fabrication processes applicable to the modified epoxy?
 - (c) Will this modification be cost effective?
 - (d) How soon can the modification be made and produced in large quantity for the aerospace industry?
 - (e) Will this modification possess the environmental durability of current epoxy?
 - (f) Will the data base already in hand with current graphite-epoxy composites have to be regenerated using this modified material? If so, how much would have to be regenerated?
 - (g) What is the main principle that the modification uses to retard graphite fiber release?
4. What is your assessment of the current NASA research program in this area, and what changes do you recommend?
5. Rank the different generic solutions (fiber modifications, fiber coatings, alternative fibers, epoxy resin modifications, epoxy resin replacements, hybrid composites) as to their probability of success.

NASA REPORTERS' SUMMARY FOR
EPOXY RESIN MODIFICATIONS WORKING GROUP

Proposed solutions involving epoxy resin modification were divided into two categories: short-term approaches and long-term approaches. The prepreggers and fabricators adamantly opposed any change to the resin or reinforcement since such modifications would require complete resin and composite requalification. The group also felt that any fix must impose a minimum weight penalty on the composite structure. Since the primary driving force for the use of graphite composite in place of the more conventional material (Al) is a 20 percent weight savings, they felt that this advantage should not be compromised.

Short-term Solutions.- Proposed short-term solutions were restricted to changes that did not involve alteration of the chemical structure or chemical content of the matrix. The group proposed the use of an outer coat of an intumescent point and/or a ply (plies) of flame retardant intumescent resin. However, the group felt that an outer intumescent surface would be unlikely to restrict the release of fibers since the char foam formed by intumescent materials is weak and friable.

Long-term Solutions.- Proposed long-term solutions included the use of flame retardant additives such as red phosphorus, phosphate compounds, aluminum hydroxide, subliming salts and trimethoxy boroxine. Unfortunately, each additive introduces its own peculiar problem such as the difficulty of obtaining and handling red phosphorus of small particle size (e.g., 1 μ m), the weight penalty associated with the use of aluminum hydroxide, and the moisture problem anticipated with the use of trimethoxy boroxine. Brominated epoxy resins were also proposed, but their poor char-forming characteristics and increased weight make them unattractive. Also, blends of epoxy resins with high char-forming non-epoxy resins such as bis-maleimides and phenolics were proposed. No changes in epoxy resin chemistry were suggested.

CONCLUSIONS

1. The present momentum in the development of graphite reinforced composites must be maintained. Any delay would severely impact the development and near-future use of these materials.

2. There is no "quick-fix" or short-term solution to the problem through modification of the epoxy matrix. The prepreggers, especially, indicated that the chemistry of epoxy resins does not permit a modification that would resolve the problem while maintaining all of the required features of a graphite-epoxy prepreg (e.g., low cost, tack and drape, shelf-life, autoclave cure at 350° F, etc.). In addition, the group complained that a lack of information existed to indicate what epoxy alterations, if any, (e.g., increased char formation) would alleviate the problem.

RECOMMENDATIONS

1. Insufficient manpower was proposed to conduct the resin modification work as proposed. Therefore, the group recommended that NASA increase its manpower loadings in this activity.
2. Inorganic coatings on graphite fiber were considered to be long-term high risk solutions. Insurmountable problems due to coefficient of thermal expansion mismatch resulting in a weak interface area and problems due to poor adhesion to epoxy resins, brittleness of the coating, and moisture sensitivity were anticipated from the use of inorganic coatings.
3. The most promising short-term solutions need more emphasis.
4. The risk analysis work should be completed as soon as possible and faster than the current proposed schedule (1.5 years).
5. A published schedule of NASA decision points such as dates for completion of the risk analysis and development of standardized tests is urgently needed.

REPORT OF
EPOXY RESIN MODIFICATIONS
WORKING GROUP

DR. JAMES NOLAND, CHAIRMAN

EPOXY RESIN MODIFICATION

OVERVIEW

- o MAINTENANCE OF PRESENT MOMENTUM
- o NO MODIFICATION OF EPOXY AS SHORT-TERM SOLUTION
- o RISK ANALYSIS NEEDS FASTER PACE
- o PUBLISHED SCHEDULE FOR DECISION - POINTS NEEDED

SHORT-TERM SOLUTIONS

- o CHANGE IN EPOXY RESIN REQUIRES TOTAL REQUALIFICATION

- o ALL SHORT-TERM SOLUTIONS INVOLVE NON-STRUCTURAL MODIFICATIONS
 - o INTUMESCENT PAINT
 - o OUTER PLYS OF FLAME-RETARDANT INTUMESCENT RESIN
 - o NO-WEIGHT OR MINIMUM-WEIGHT PENALTY

LONG-TERM SOLUTIONS

-EPOXY RESIN MODIFICATION-

- o IMPROVED FIRE RESISTANT ADDITIVES
 - o RED PHOSPHOROUS AND PHOSPHORUS COMPOUNDS
 - o ALUMINUM HYDROXIDE
 - o SUBLIMING SALTS
 - o ENCAPSULATED TRIMETHOXY BOROXINE
 - o BROMINATED EPOXY RESINS (UNLIKELY SOLUTION)

-CHANGES IN RESIN CHEMISTRY-

- o PHENOLIC CURES
- o BIS-MALEIMIDE BLENDS
- o OTHERS!

RANKING OF LONG-TERM SOLUTIONS

PRIORITY

- 1 EPOXY REPLACEMENTS
- 2 FIBER COATINGS (ORGANIC)
- 3 HYBRIDS
- 4 EPOXY MODIFICATIONS

RECOMMENDATIONS

- o SCOPE OF RESIN MODIFICATIONS TOO BROAD FOR MANPOWER LOADINGS: RECOMMEND INCREASED MANPOWER
- o INORGANIC FIBER COATINGS ARE LONG-TERM, HIGH RISK SOLUTIONS
- o SHORT-TERM SOLUTIONS NEED MORE EMPHASIS
- o NASA ROADMAP URGENTLY NEEDED

EPOXY RESIN REPLACEMENTS
Dr. B. F. Landrum, Chairman

NAME	ORGANIZATION
Ira Petker	Composites Horizons
Lynn Jarvis	Naval Research Lab
Chad Delano	Acurex/Aerotherm
Dan Scola	United Technologies Res. Ctr.
W. F. Baumgartner	Lockheed-California
Norm Bilow	Hughes Aircraft Co.
Henry M. Toellner	McDonnell Douglas
Walter S. Cremens	Lockheed-Georgia
Rick Moulton	Hexcel
Don Houston	Rockwell - Space
Jim Gauchel	DeSoto Inc.
William J. Bailey	U. of Maryland
John Parker	NASA Ames
Ronald Stocks	CIA OSI/LSD
Rex Gosnell	Riggs Engineering
Ed Harrison	General Dynamics/Convair
Vance Chase	General Dynamics/Conair
William Verzino	Aerospace Corp.
Mike O'Rell	TRW Systems
John T. Hoggatt	Boeing Aerospace
Hugh H. Gibbs	DuPont
Bill Landrum	Ciba-Geigy Corporation
George Sykes	NASA LaRC
NASA Reporter - Dr. Terry St. Clair, LaRC	

ISSUES FOR
EPOXY RESIN REPLACEMENTS
WORKING GROUP

1. What principles would be employed by replacement resins to retard fiber release?
2. What combination of properties must a resin possess in order to replace epoxy and at the same time retard fiber release?
3. Are aromatic polyimides a good candidate resin system to replace epoxy for the purpose of retarding fiber release?
4. For each epoxy replacement resin proposed:
 - (a) Are current synthetic and fabrication processes applicable to the new resin? Could improved processes be developed?
 - (b) Will this new resin be cost effective?
 - (c) Will this new resin possess the environmental durability of current epoxy?
 - (d) What is the main principle that this new resin would employ to retard fiber release?
 - (e) How soon can this new resin be produced in large quantity for the aerospace industry?
4. What is your assessment of the current NASA research program in your area, and what changes do you recommend?
5. Rank the generic solutions (fiber modifications, fiber coatings, alternative fibers, epoxy resin modifications, epoxy resin replacements, hybrid composites) as to their probability of success.

NASA REPORTERS' SUMMARY FOR
EPOXY RESIN REPLACEMENTS WORKING GROUP

The meeting was prefaced with four presentations which are summarized below.

1. Lynn Jarvis (NRL) - This was a summary of NRL work on polyphthalocyanine (PPCy). The polymer is a high char former, is made from a single monomer, has a high degree of toughness, and may be available for as little as \$10/lb within 2 years. NRL is still modifying the chemistry of the system. The current versions have a 410-490°F cure and afford a dry, boardy prepreg. Very little data base exists for the PPCy. The group consensus was that this material needs further development before commercial applications could be realized.

2. Bill Bailey (U. of Maryland) - This was a presentation on the need for epoxy replacements to have low shrinkage. He feels that low shrinkage will minimize microcracking which promotes resin burnout. He also feels that lower shrinkage will cause better resin-to-fiber adhesion which would help hold the fibers together in a fire/explosion scenario. He presented the chemistry of a material he has developed which has applications as a dental adhesive because of its low shrinkage. The resin did not have the high temperature capability of 350°F cure epoxies.

3. Mel Katsumoto (Boeing) - This was a summary of the problems a commercial airplane builder faces in qualifying a resin for use on aircraft. He charged the group to look for a "quick fix," such as a composite protective coating, to solve the current fiber release problem, then formulate a long-term program to develop an epoxy replacement resin.

4. Raymond Kray (Ciba-Geigy) - This was a summary of some of the NCNS resin work performed on contract to NASA-Langley. Data were shown on NCNS's excellent resistance to burning, and the slight intumescent behavior of NCNS/graphite laminates was described. NCNS is not commercially available, at present, but may be in approximately one year. The resin is projected to cost about \$5-\$8/lb.

In response to the strawman issues posed by NASA to the group, a list was compiled of the properties that an effective epoxy replacement resin should possess.

1. It should have a high char yield and produce a tough char.

2. It should be intumescent.
3. It should have mechanical properties equal to those of the current epoxies.
4. It should have a high limiting oxygen index (LOI).
5. Its properties should match ignition and burn properties of the fiber.
6. It should be UV resistant.
7. It should meet processing requirements of current epoxies.
8. It should present no unacceptable toxic or environmental hazard.
9. It should be moisture stable.
10. It should sell for \$10/lb or less.
11. It should have a maximum cure temperature of 350°F and preferably lower.

In response to the chairman's request for potential epoxy replacement resins from currently available materials, the following list of possible candidates was compiled:

1. Polyimides and Cyanates

- LaRC 160
- PMR-15 (First and Second Generation)
- NR-150 A2
- Thermid 600
- Hexcel F-178
- N-Cyanosulfonamide (NCNS)
- Triazine A

2. Phenolics and Miscellaneous

- Xylok
- Weyerhaeuser benzyl resin
- Phenolic prepregs from Ciba-Geigy, Fiberite, Hitco, and Narmco
- Polyphthalocyanines (PPCy)
- Polyphenylene sulfides
- Aryl sulfones
- Thermally cross-linked thermoplastics

CONCLUSIONS

1. For a short term solution, only existing resin systems should be considered as replacements for epoxy.
2. Toughness is an important property to be considered in evaluating potential replacement resins.
3. Hybrid composites and/or fiber coating concepts offer the best hope for a "quick fix" to the graphite fiber hazard. Fiber modification is the least promising approach.

RECOMMENDATIONS

1. NASA should conduct a screening test program on existing replacement resins to characterize their burn properties and identify promising candidates. Selection of systems for further research should be based on fabrication parameters such as prepreggability, handleability, and processability into laminates and on mechanical properties of composites.
2. NASA should appoint an Epoxy Replacement Panel that should meet every six months to review and discuss progress.

REPORT OF
EPOXY RESIN REPLACEMENTS
WORKING GROUP

DR. B. F. LANDRUM, CHAIRMAN

EPOXY RESIN REPLACEMENTS

OVERVIEW

PRINCIPLES TO BE EMPLOYED

CRITICAL PROPERTIES

PROMISING KNOWN SYSTEMS

PROBABILITY OF SUCCESS

ASSESSMENT OF CURRENT NASA PROGRAM

DESIRED RESIN CHARACTERISTICS

A NEW RESIN TO BE AN EFFECTIVE EPOXY REPLACEMENT MUST EMPLOY AS MANY OF THE FOLLOWING PRINCIPLES AS POSSIBLE -

- o HIGH CHAR FORMATION
- o INTUMESCENT
- o HIGH LIMITING OXYGEN INDEX
- o MATCH IGNITION & BURN CHARACTERISTICS OF FIBER
- o PRODUCE TOUGH CHAR WITH GOOD FIBER ADHESION
- o EXHIBIT ACCEPTABLE PROCESSING CHARACTERISTICS
- o DEMONSTRATE EPOXY MECHANICAL PROPERTIES
- o SELL FOR \$10.00/LB OR LESS
- o PRESENT NO UNACCEPTABLE TOXIC OR ENVIRONMENTAL HAZARD IN PROCESSING

CONSENSUS CONCLUSION

CURRENTLY AVAILABLE, WELL KNOWN RESIN SYSTEMS CANNOT BE RANKED IN ORDER OF PROMISE DUE TO LACK OF A SYSTEMATIC SCREENING STUDY BY A CENTRAL CLEARING HOUSE OR AUTHORITY.

RECOMMENDATION:

NASA ESTABLISH A SET OF STANDARD EVALUATION PROCEDURES AGAINST WHICH CANDIDATE RESIN PROPERTIES WILL BE DETERMINED.

POLYIMIDES & CYANATES

LaRC 160

PMR - 15 (1st & 2nd GENERATION)

NR - 150 A2

THERMID 600

F - 178

NCNS

TRIAZINE A

PHENOLICS & MISCELLANEOUS

XYLOK

WEYERHAUSER BENZYL RESINS

PHENOLIC PREPREG -

NARMCO

FIBERITE

CIBA-GEIGY

HITCO

POLYPHTHALOCYANINES

THERMOPLASTICS

POLYPHENYLENE SULFIDES

ARYL SULFONES

THERMALLY CROSS LINKED THERMOPLASTICS

CURRENT NASA PROGRAM ASSESSMENT

- o GOOD START
- o NEED OPEN SCREENING OF AVAILABLE RESINS
- o NEED BETTER DEFINITION OF REALISTIC SCREENING CRITERIA.
- o EFFORTS SHOULD BE CONCENTRATED ON DEVELOPING 3 OR 4 MOST PROMISING SYSTEMS.
- o NEED EARLY FEEDBACK FROM PREPREGGERS AND FABRICATORS

SUMMARY OF RECOMMENDATIONS

- o SCREEN KNOWN RESIN SYSTEMS AGAINST A SET OF STANDARD CRITERIA
- o SELECT MOST PROMISING CANDIDATES ABOVE FOR FURTHER EVALUATION
- o COMPARE COST/PERFORMANCE AND SELECT MOST PROMISING FOR FULL SCALE DEVELOPMENT
- o NASA SHOULD REQUEST DATA FROM RESIN PRODUCERS CONCERNING PERTINENT RESIN PROPERTIES
- o UNDERTAKE SELECTIVE SYNTHETIC MODIFICATIONS TO EXISTING RESIN SYSTEMS
- o ESTABLISH INDUSTRY/GOVERNMENT/UNIVERSITY REVIEW BOARD TO ASSESS PROGRESS

NRL WORK ON POLYPHTHALCYANINE

LYNN JARVIN
NRL

MARCH 23, 1978

POLYMERIZATION REACTION

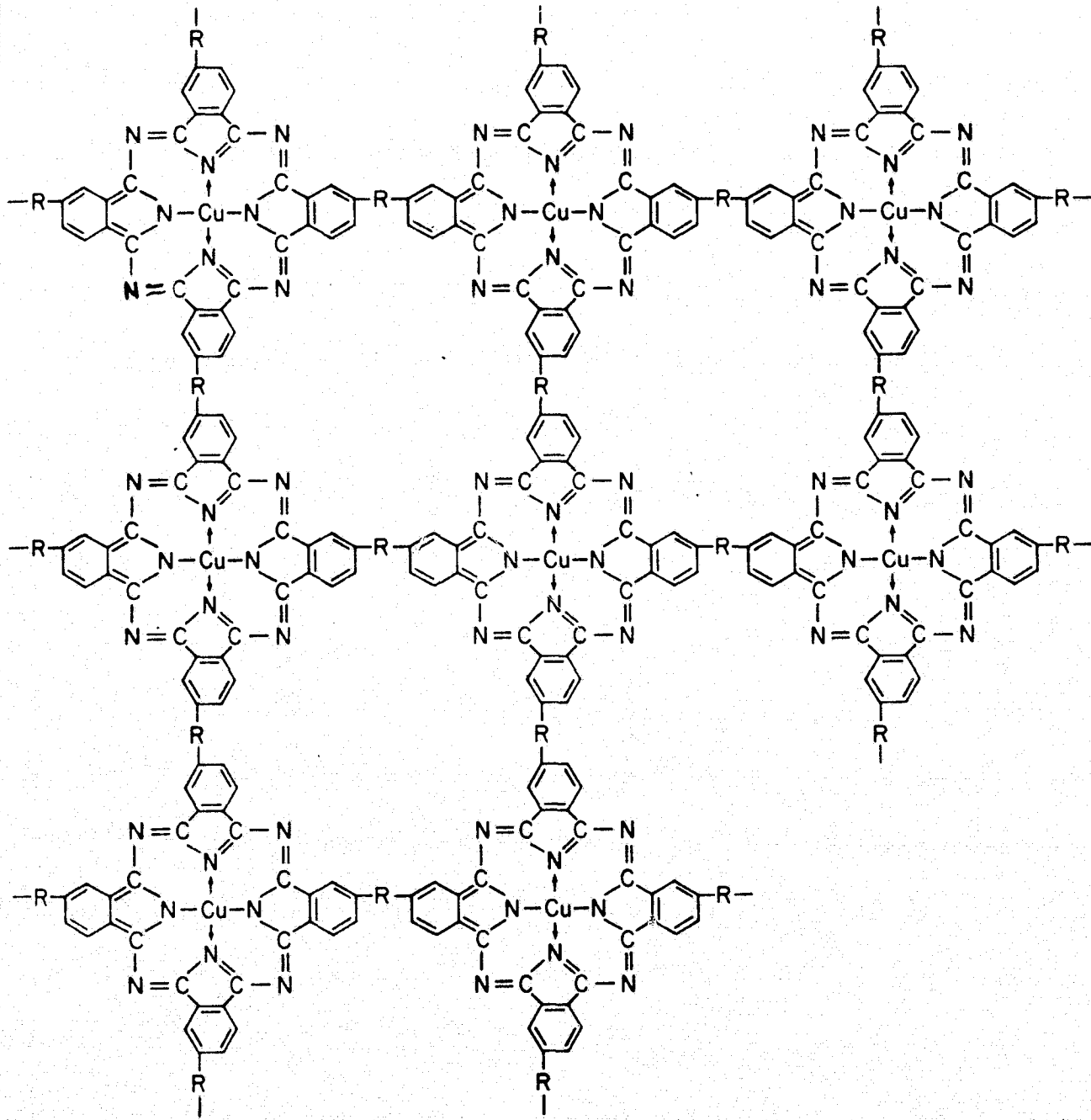
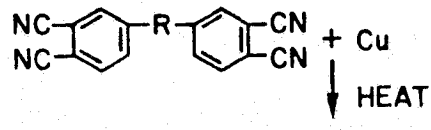

POSSIBLE RESEARCH DIRECTIONS

- MAY INCREASE CHAR YIELD BY:
 - ADDITION OF AROMATIC GROUPS TO R
 - ADDITION OF SUITABLE METAL ATOMS (Sn_{1--})
- MODIFY SYNTHESIS TO REDUCE COST
- MAINTAIN PROPERTIES AS MATRIX MATERIAL

ADVANTAGES OF POLYPHTHALOCYANINES

- ONE PHASE SYSTEM
- INFINITE SHELF LIFE
- POTENTIAL LOW COST (~ \$10/LB)
- EASILY PROCESSED
- NO VOLATILES ON CURING (NO VOIDS)
- HIGH CHAR YIELD POSSIBLE

PHTHALOCYANINE REACTION

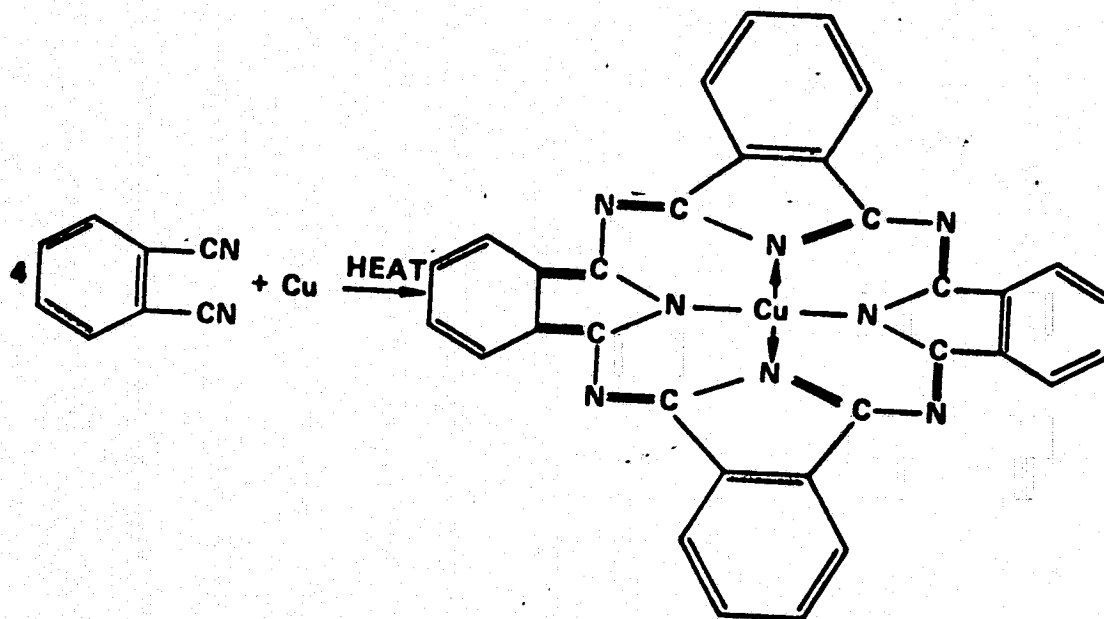

252

NRL

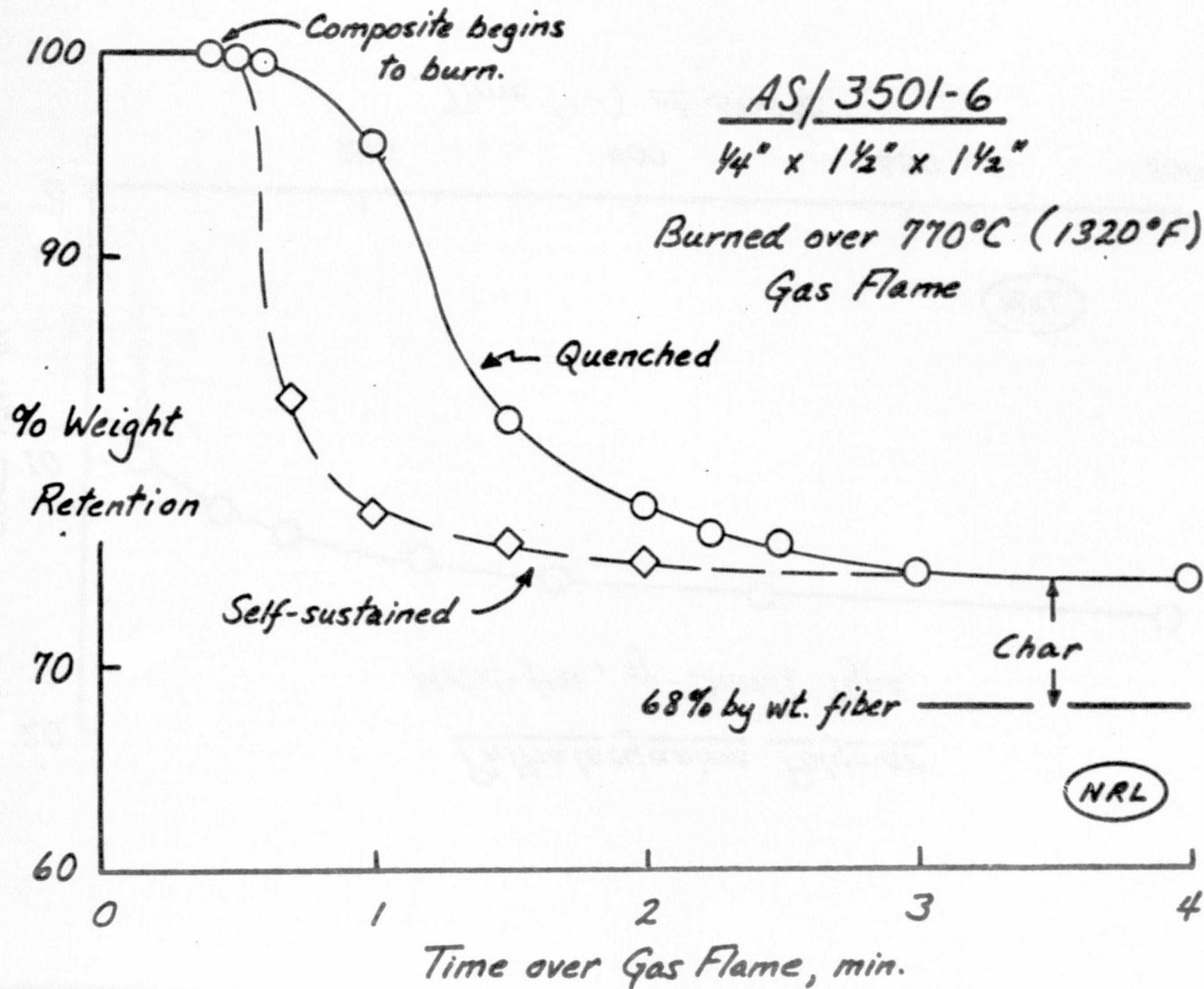

Phthalocyanine Polymer

Metal-free, *p*-Dianil Type

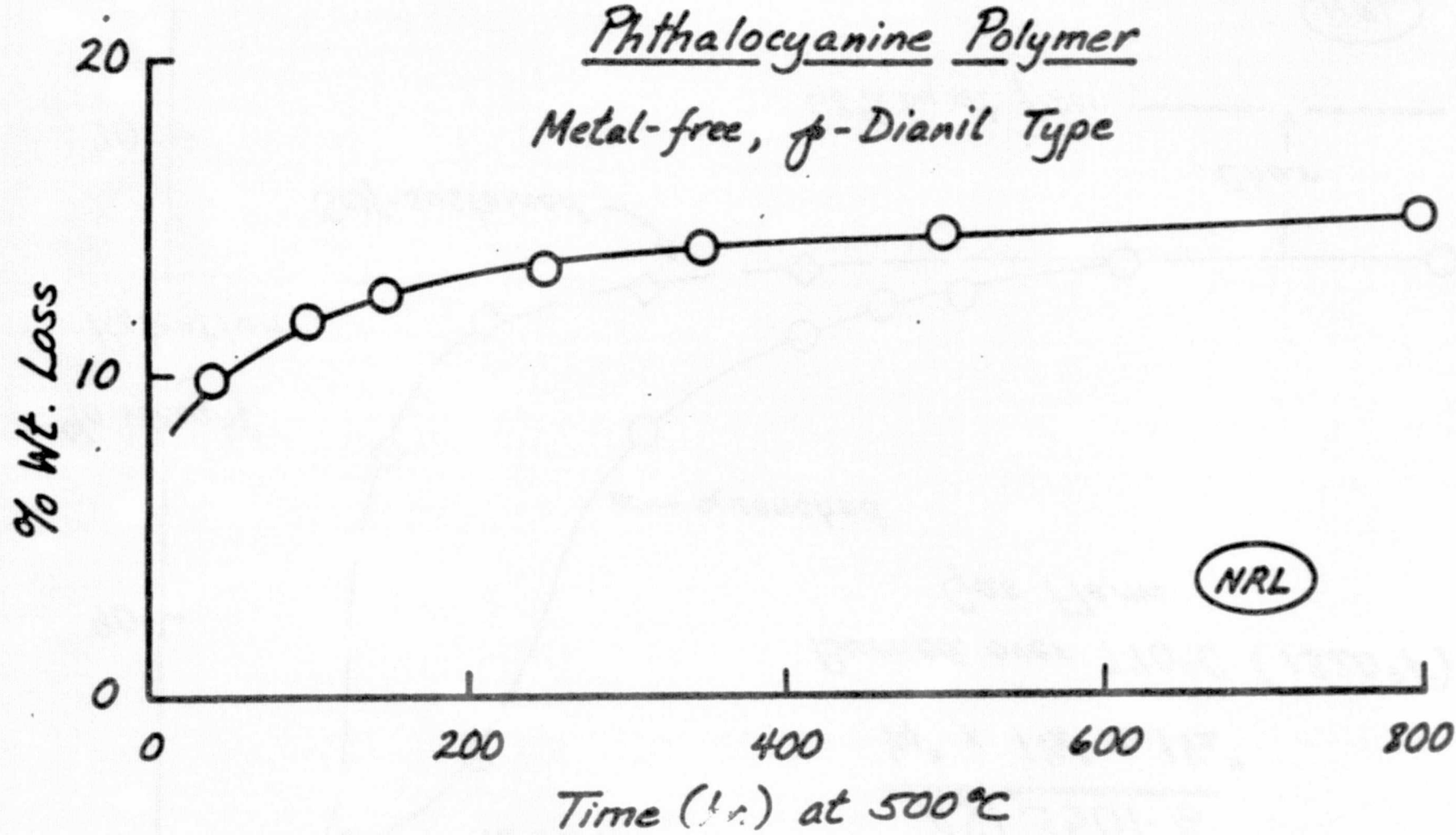

Composites from 770°C Gas Fire

Composite	Resin Type	% Char Yield	Char/Fiber, wt. ratio	Appearance after Burning
AS/3501-6	Hercules epoxy	19	0.28	Completely delaminated
T300/5208	Narmco epoxy	19	0.29	
T300/F178	Hexcel polyimide	43	0.17	Solid block
T300/C-10	NRL poly-phthalocyanine	50	0.14	Partially delaminated

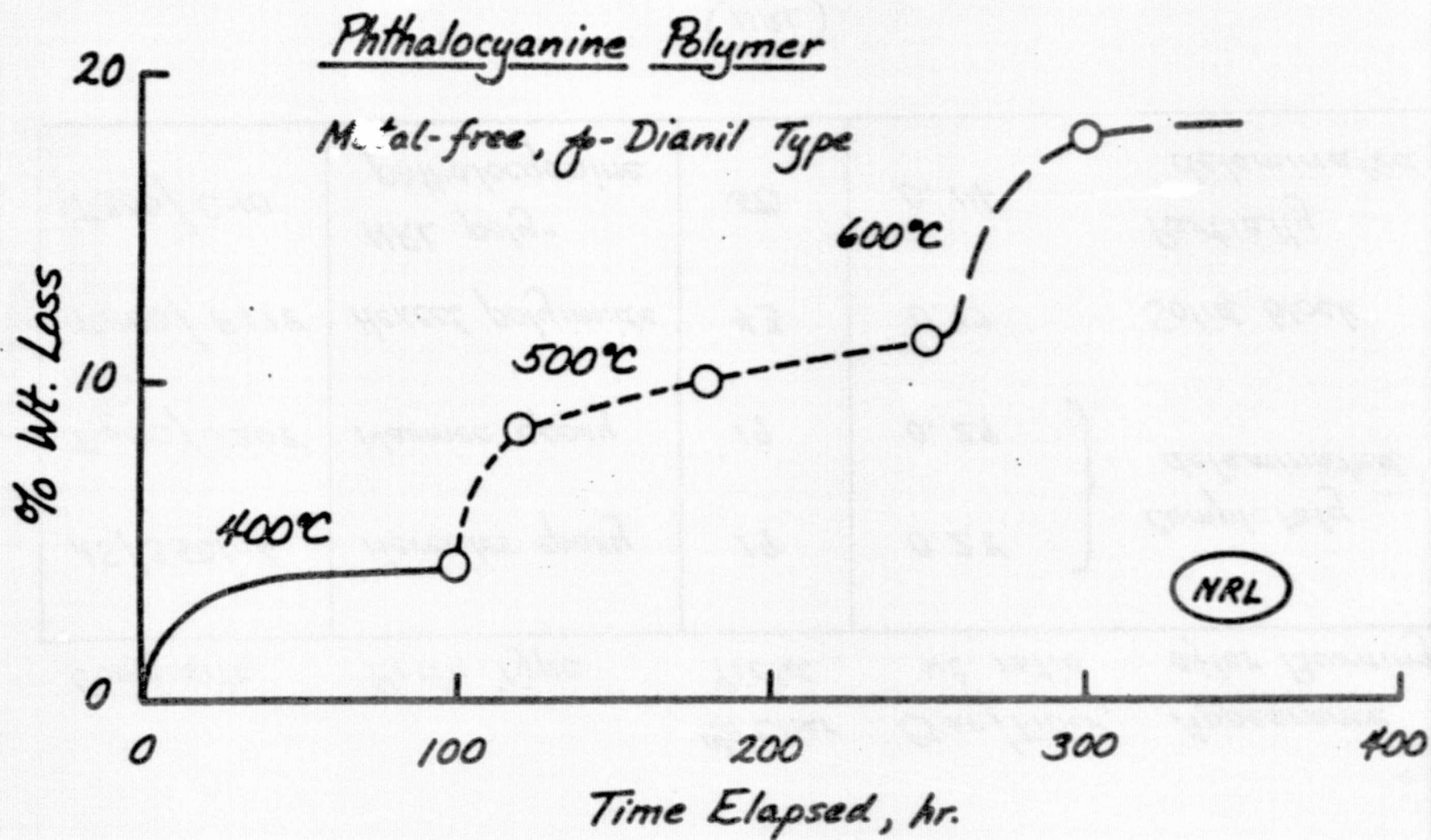

NCNS RESINS

RAY KRAY

CIBA-GEIGY

MARCH 23, 1978

COMPOSITION AND CURING MECHANISM
OF N-CYANOSULFONAMIDE LAMINATING RESIN

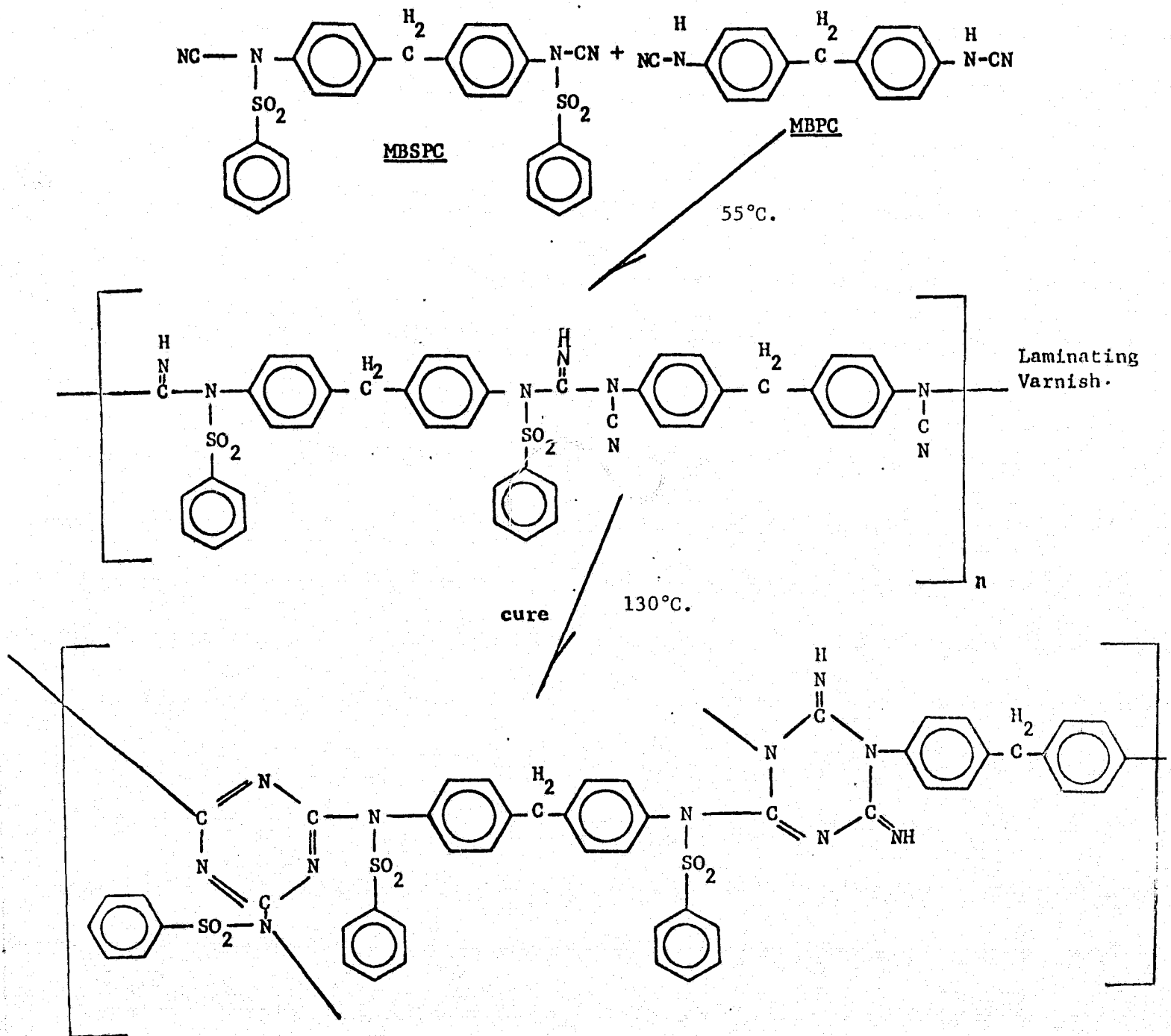

ORIGINAL PAGE IS
OF POOR QUALITY

NCNS-13P RESIN PILOT PLANT BATCH NO. 7/7/1002

LAMINATING VARNISH I-25R-99	30% NCNS-13P IN 60/40 METHANOL/ETHYL ACETATE
REINFORCEMENT	UNIDIRECTIONAL AS GRAPHITE FIBER
B-STAGING CONDITIONS FOR PREPREG	70°C/75 MIN. - 85°C/15 MIN.
NO. OF PLYS	15
PRESS LAMINATION CONDITIONS	350°F/300 PSI/1 HR.
POST CURE CONDITIONS	425°F/7 HRS. - 460°F/8 HRS.
RESIN SOLIDS CONTENT	30.3%
FIBER VOLUME	64.8%
VOID CONTENT	NONE
400°F SHORT BEAM SHEAR STRENGTH, PSI	11,400
400°F FLEXURAL STRENGTH, PSI	237,000
400°F FLEXURAL MODULUS, KSI	17,200

TMA Z-AXIS THERMAL EXPANSION
OF 110 MIL THICK NCNS-13P LAMINATE

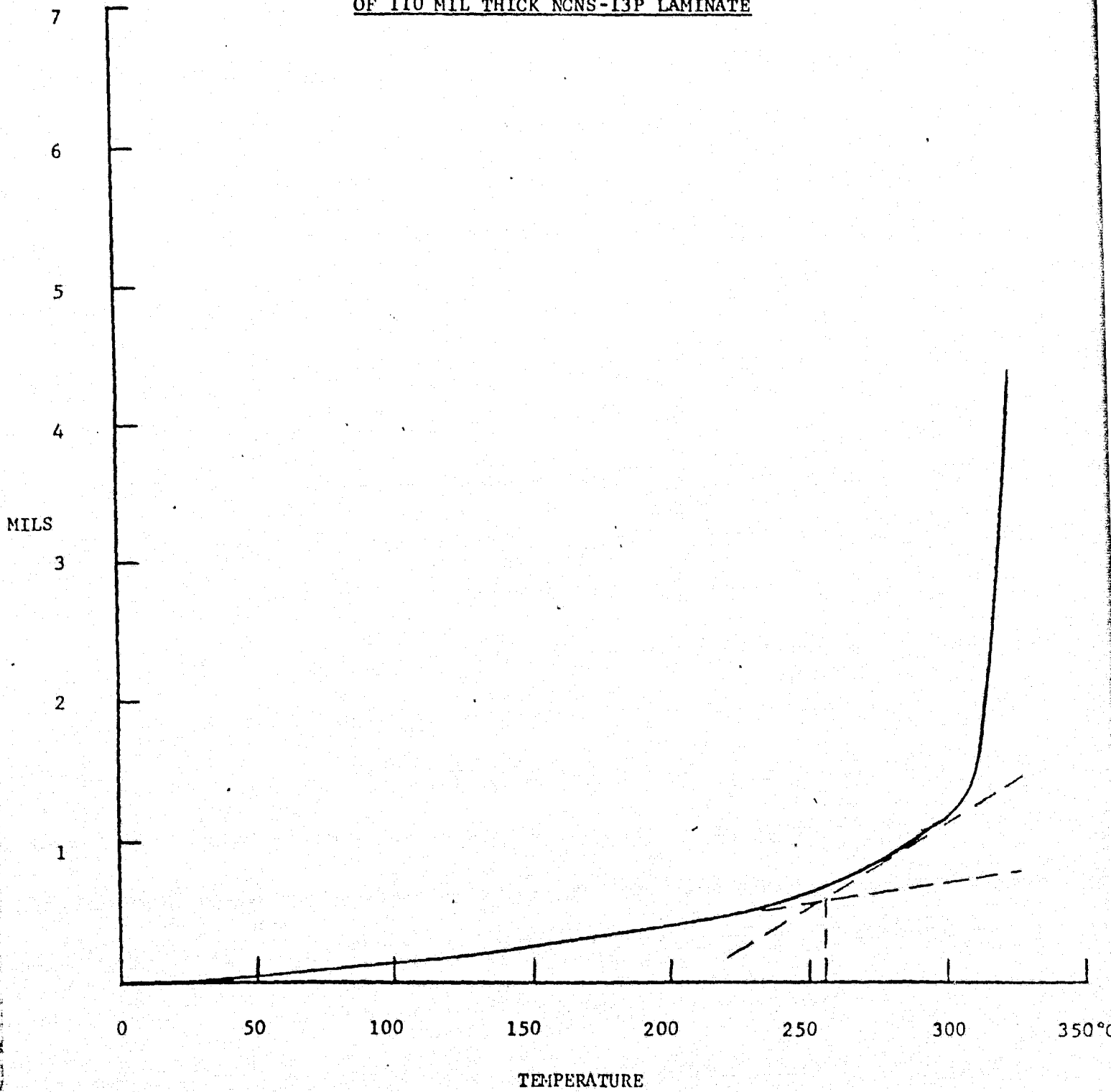

FIGURE 14

FLAMMABILITY AND SMOKE GENERATION

	<u>1:2 NCNS RESIN</u>	<u>P13N RESIN</u>	<u>XYLOK 210</u>
OXYGEN INDEX OF NEAT RESIN	29	31	--
RESIN CONTENT OF 181E GLASS LAMINATE	30	27	30
OXYGEN INDEX OF LAMINATE	86.2	--	69
MAXIMUM SPECIFIC OPTICAL DENSITY (DM)			
FLAMING	20	20	123
NON-FLAMING	6	0.3	44
TIME IN MINUTES TO DEVELOP SPECIFIC OPTICAL DENSITY = 16 (DS)			
FLAMING	6.6	7.5	1.8
NON-FLAMING	NOT REACHED	NOT REACHED	11.5

NON-BURNING CHARACTERISTICS OF
NCNS/181E GLASS CLOTH LAMINATES

NO.	95
RESIN	NCNS-12M
RESIN CONTENT	22.8%
FAA VERTICAL BURN TEST 25.853A*	
FLAME TIME IN SECONDS	6.2
BURN LENGTH IN INCHES	1.1
LIMITING OXYGEN INDEX (LOI)	NON-BURNING IN 100% O ₂

*ALL SAMPLES WERE SELF EXTINGUISHING AND DID NOT DRIP.

NBS SMOKE DENSITY ON GLASS LAMINATES

263

SPECIFIC
OPTICAL
DENSITY
 D_s

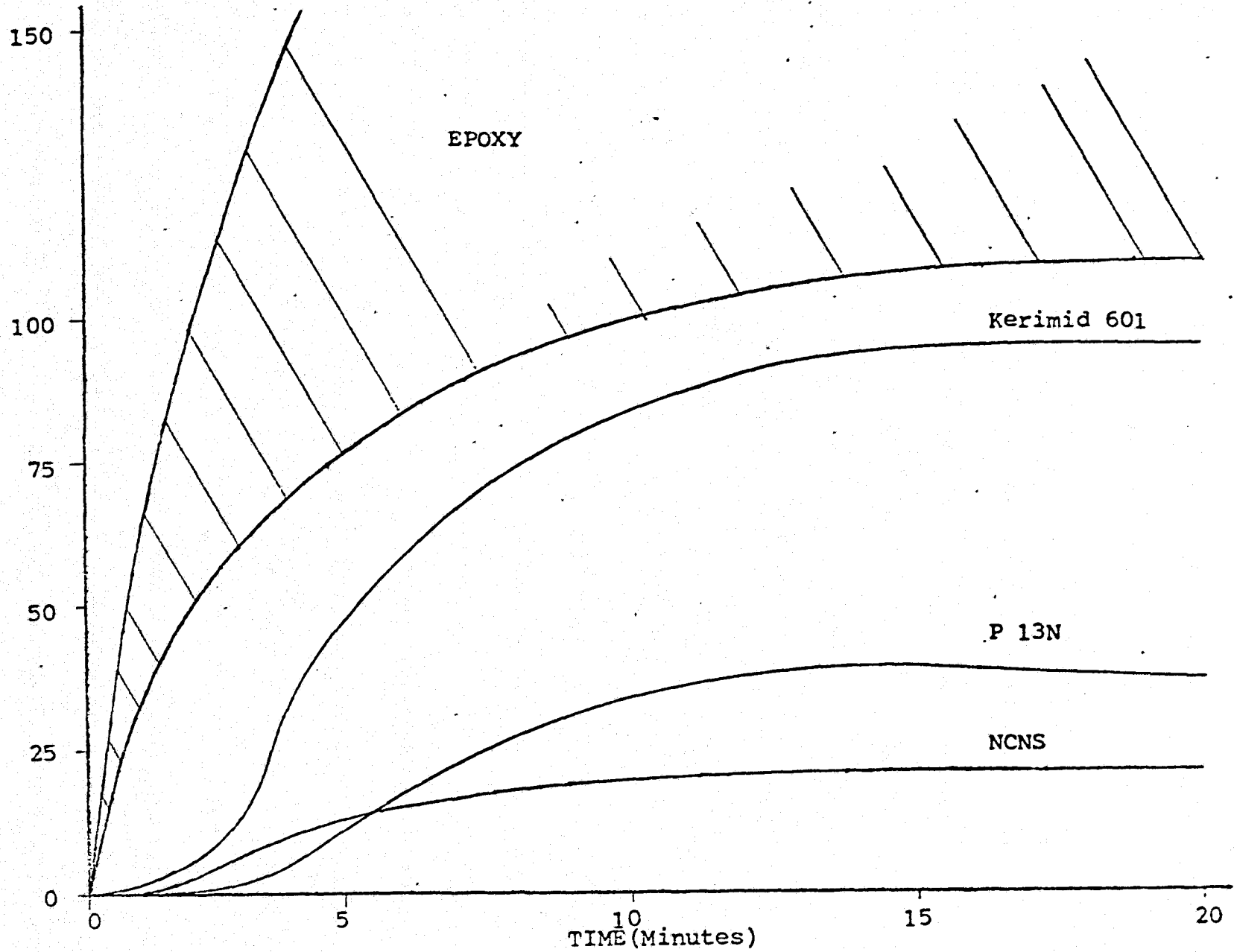

NBS SMOKE DENSITY MEASUREMENTS UNDER
FLAMING CONDITIONS ON NCNS RESINS LAMINATES

SPECIFIC
OPTICAL
DENSITY (D_s)

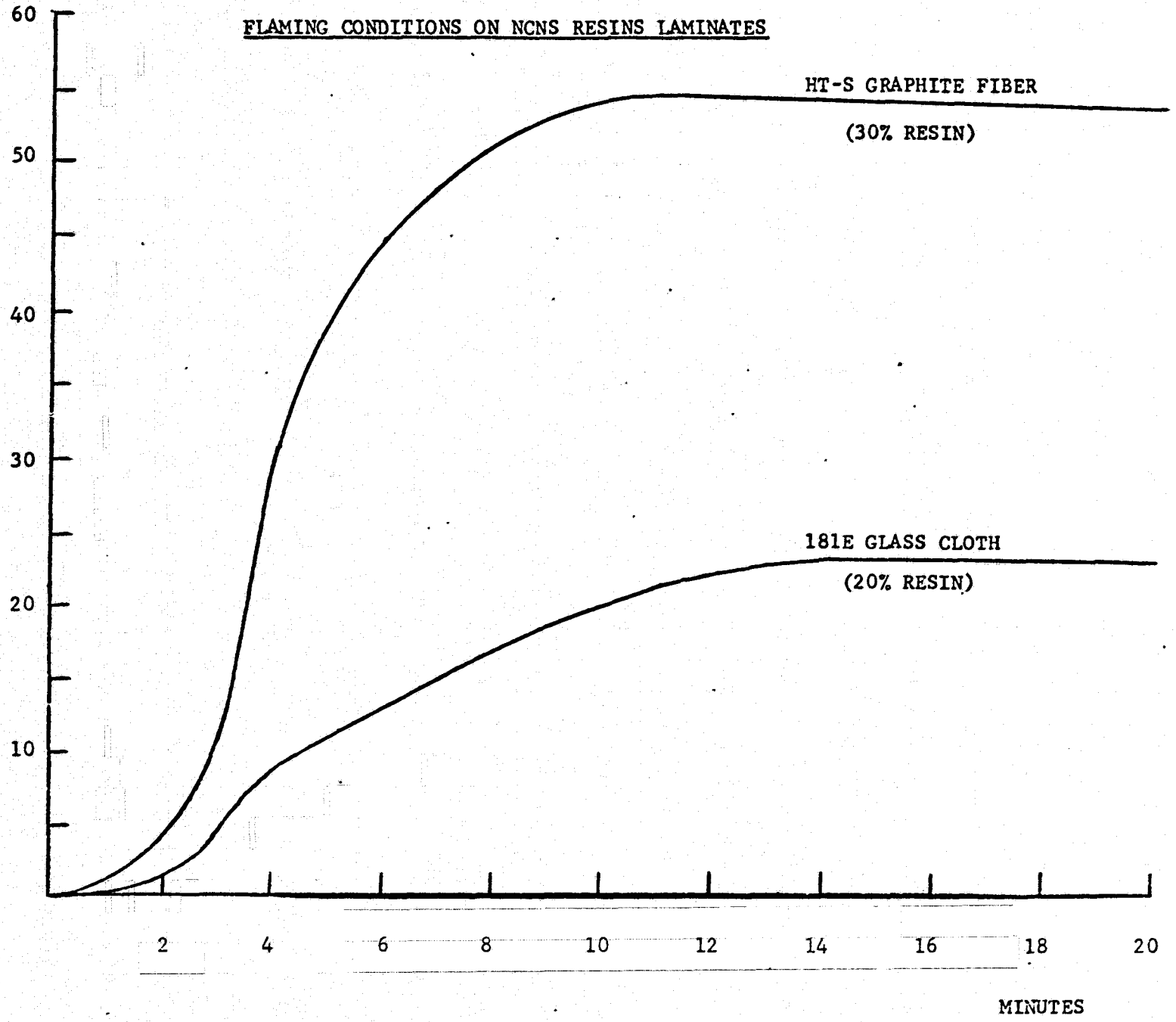

264

TOXIC GASES FROM NCNS-13P/181E GLASS
FABRIC LAMINATE I-24A-119A IN NBS
SMOKE DENSITY CHAMBER

D_M			12		
TIME IN MINUTES	5	10	15	20	
CO, PPM	10	30	70	110	
HCN, PPM	1*	2	3.5	5	
SO ₂ , PPM	2.5	5	5	5	
NO _x , PPM	0.5	1	2	2	

*COMPARATIVE VALUE FOR POLYIMIDE 3002 (DUPONT) WAS
15 PPM FOR HCN (D. ARNOLD & G. JOHNSON, BOEING,
SAMPE SYMPOSIUM APRIL 1977).

LOW SHRINKAGE RESINS

BILL BAILEY
UNIVERSITY OF MARYLAND

MARCH 23, 1978

266

Bailey

MONOMER	SPECIFIC GRAVITY		SHRINKAGE
	MONOMER	POLYMER	%
VINYL CHLORIDE	0.919	1.406	34
ACRYLONITRILE	0.797	1.17	31
METHYL METHACRYLATE	0.940	1.19	21
VINYL ACETATE	0.932	1.19	21
STYRENE	0.907	1.06	15
DIALLYL. PHTHALATE	1.12	1.27	12

SHRINKAGE DURING RING-OPENING POLYMERIZATION

MONOMER	d_4^{20}	POLYMER d_4^{20}	SHRINKAGE, %
ETHYLENE OXIDE	0.869	1.13	23
PROPYLENE OXIDE	0.830	1.002	17
²⁶⁸ CYCLOPENTENE	0.772	0.91	15
STYRENE OXIDE	1.05	1.15	9
CYCLOOCTENE	0.849	0.89	5
CYCLODODECATRIENE	0.885	0.91	3

ORIGINAL PAGE IS
OF POOR QUALITY

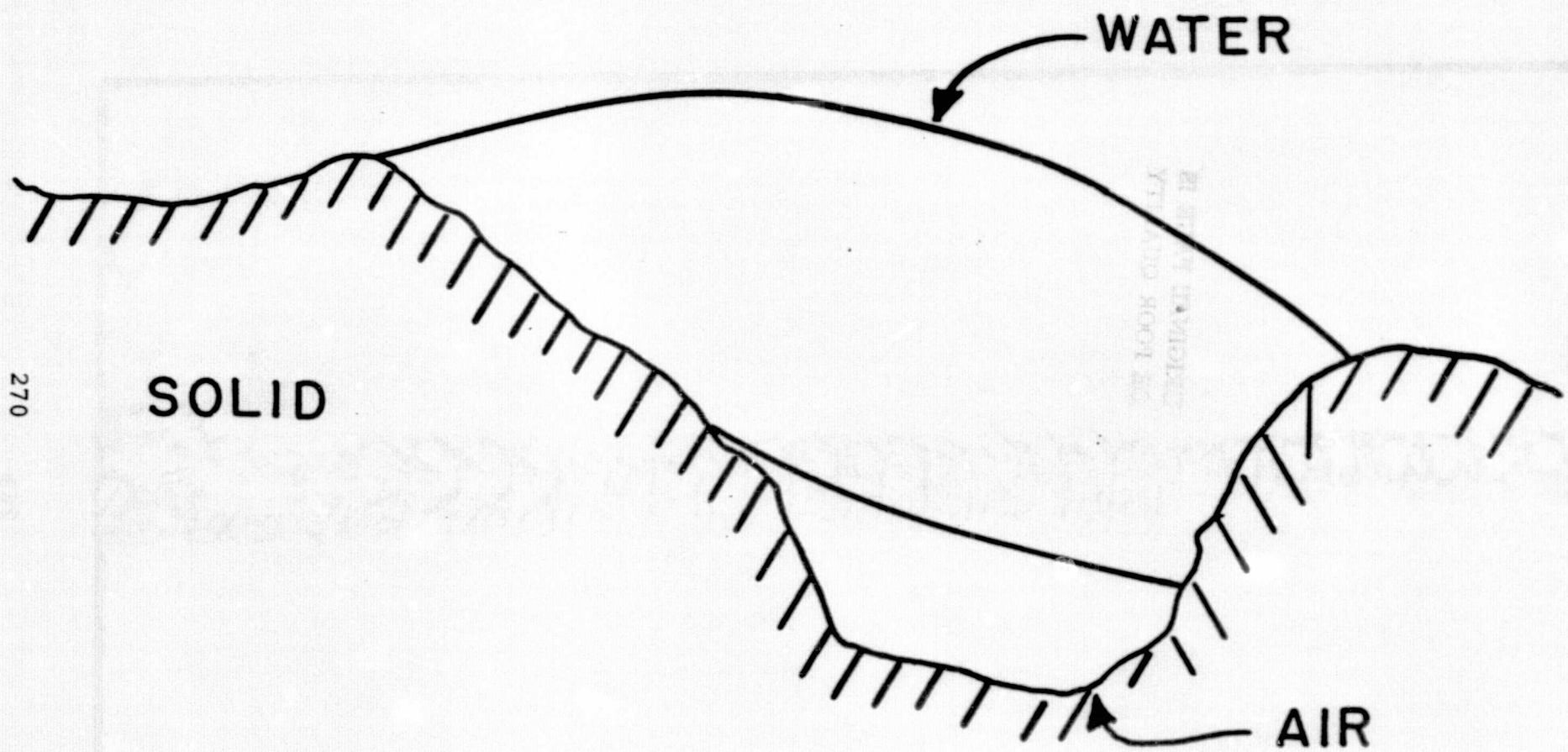

MECHANICAL ATTACHMENT OF ICE TO A ROUGH SURFACE

SHRINKAGE DURING RING-OPENING POLYMERIZATION

VAN DER WAALS
DISTANCE

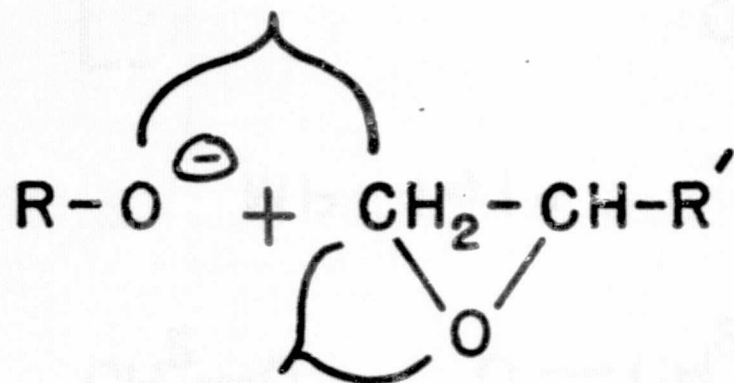

COVALENT
DISTANCE

COVALENT
DISTANCE

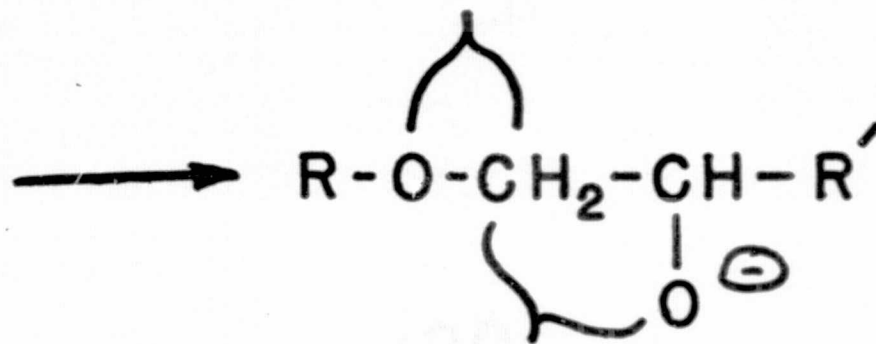

NEAR VAN DER WAALS
DISTANCE

3-5% SHRINKAGE

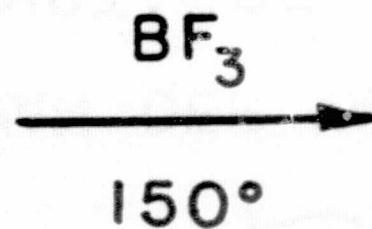
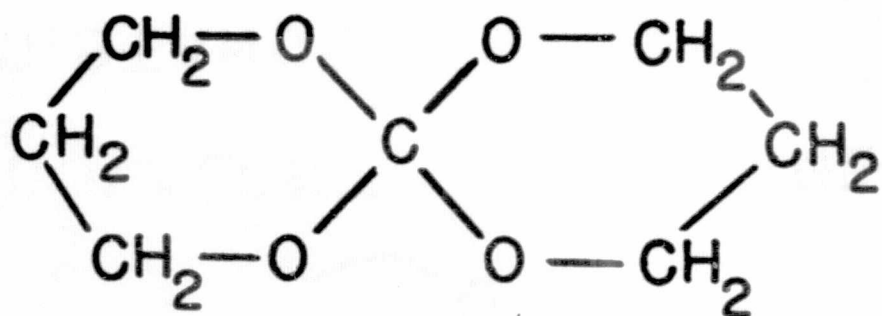

MP 141°

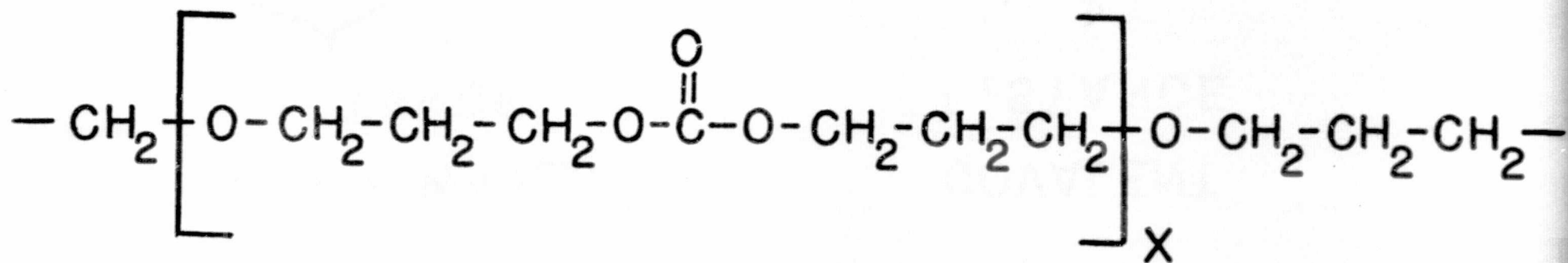

Densities of the Monomeric Spiro Ortho Carbonate
and Related Polycarbonate versus Temperature

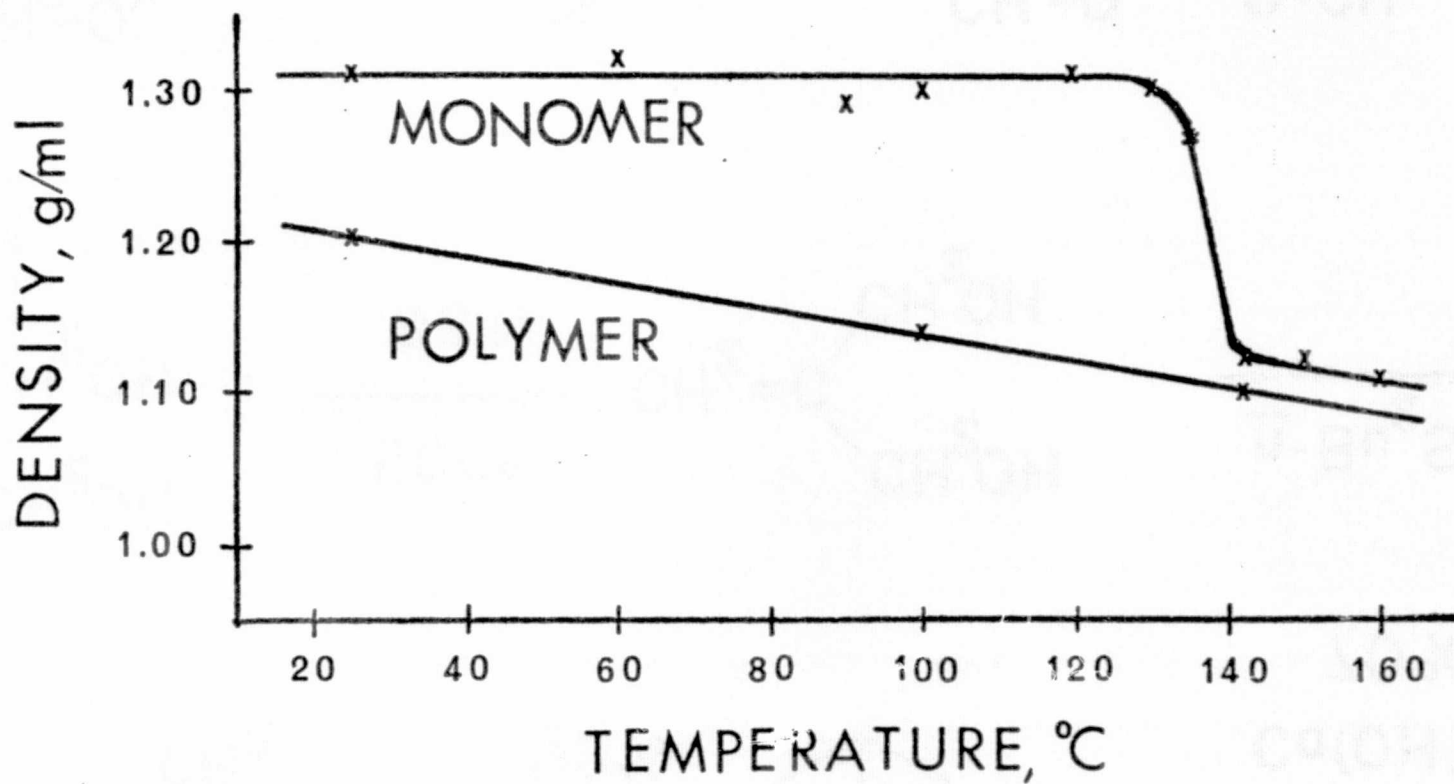

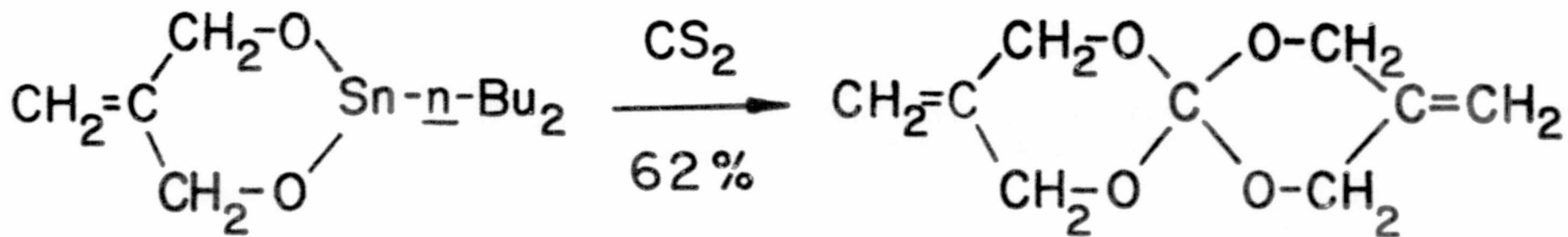
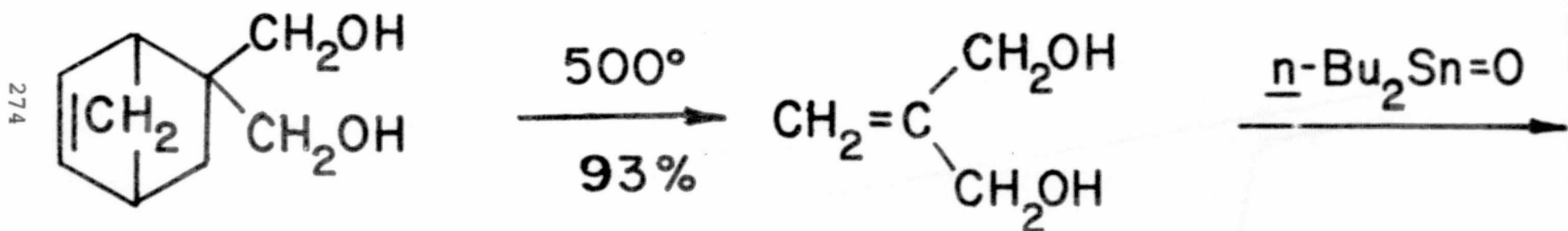
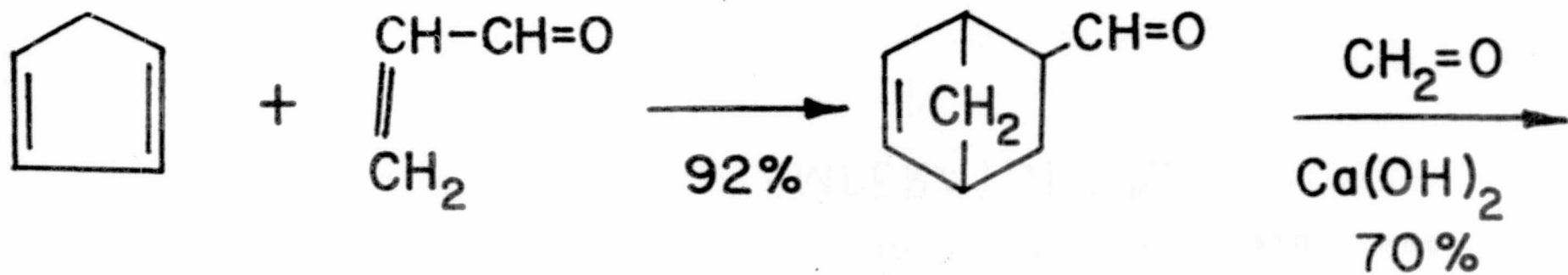

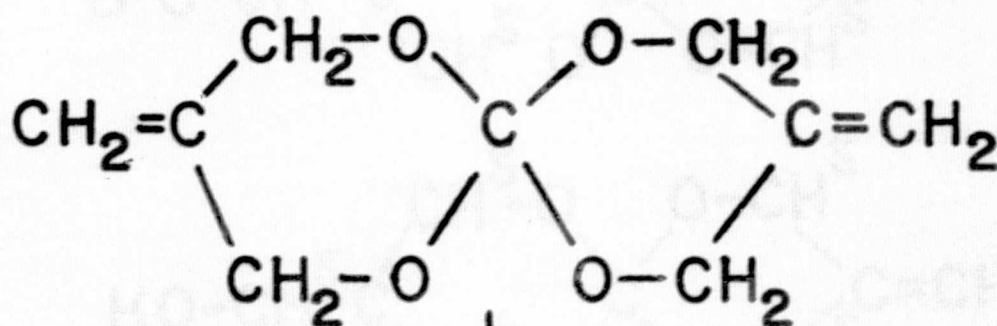
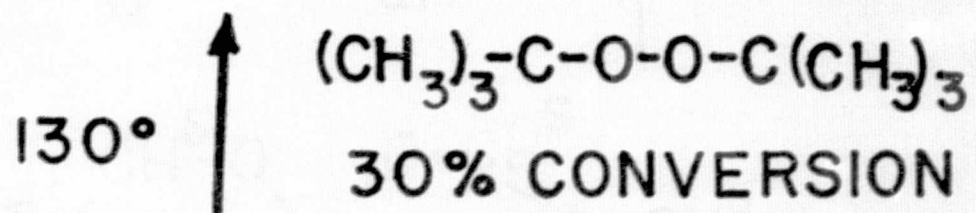
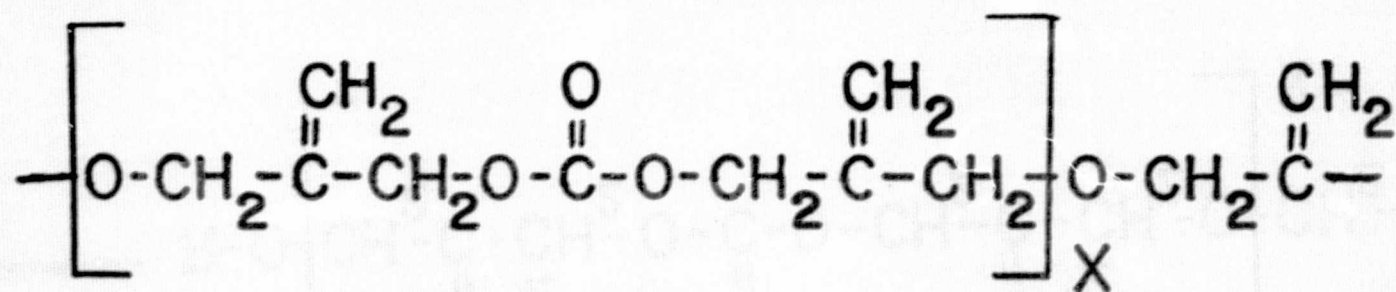

m.p. 82°

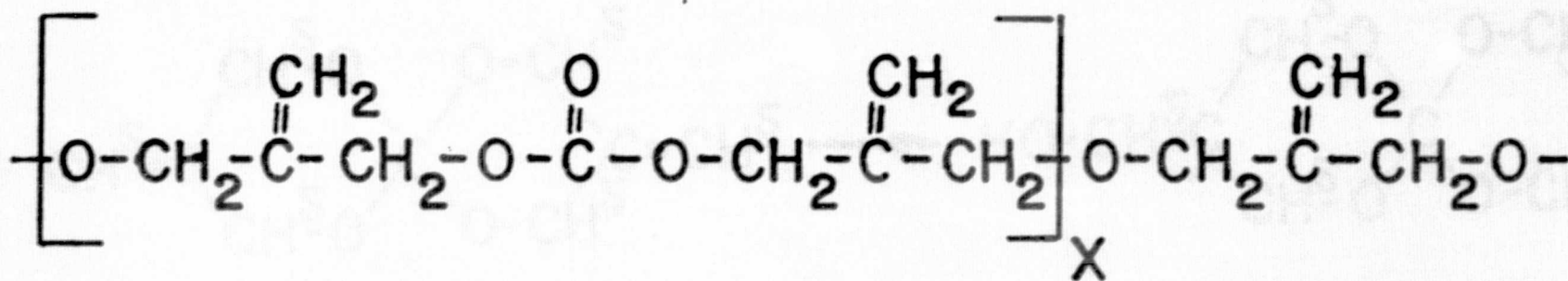
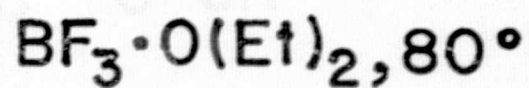

80% SOLUBLE; $[\eta] = 0.24$ ($\text{CHCl}_3, 25^\circ$)

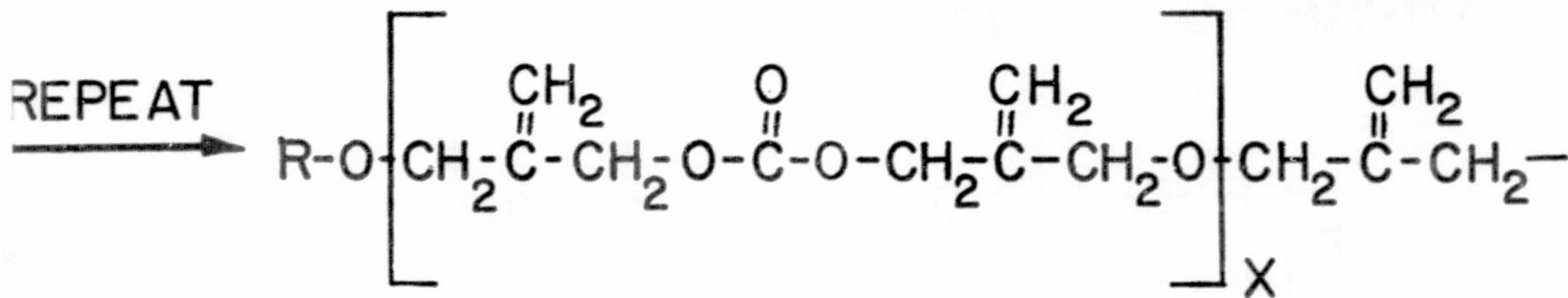
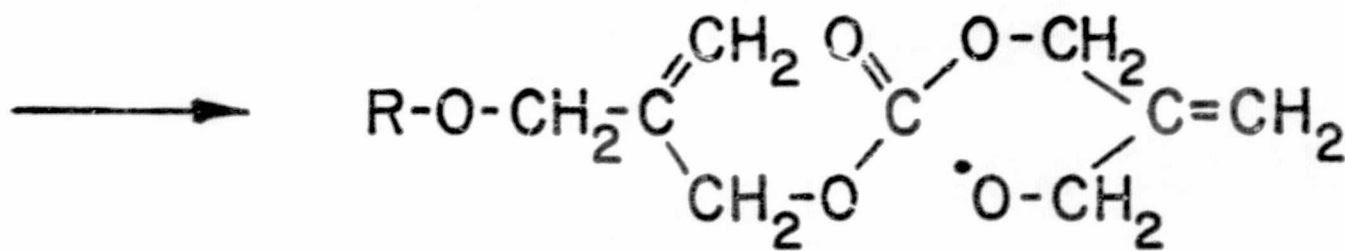
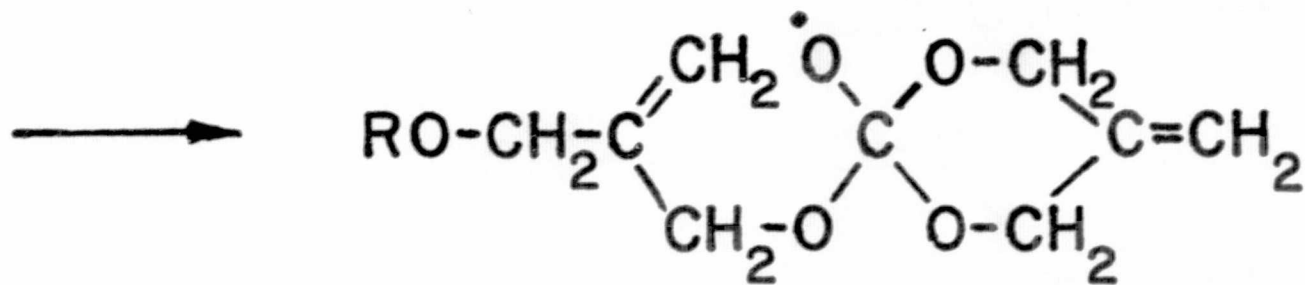
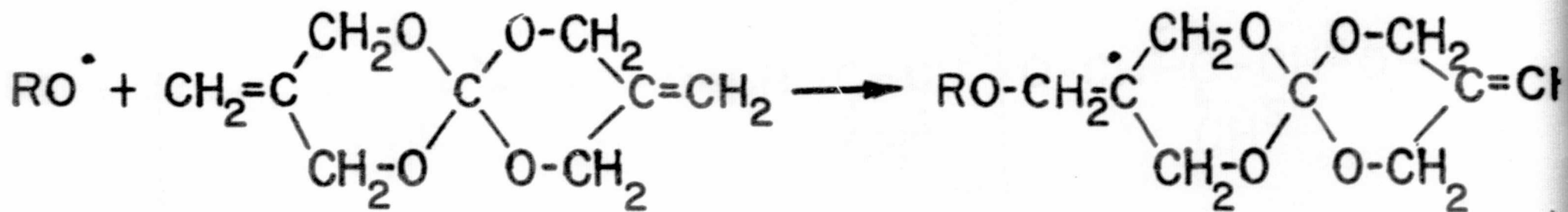

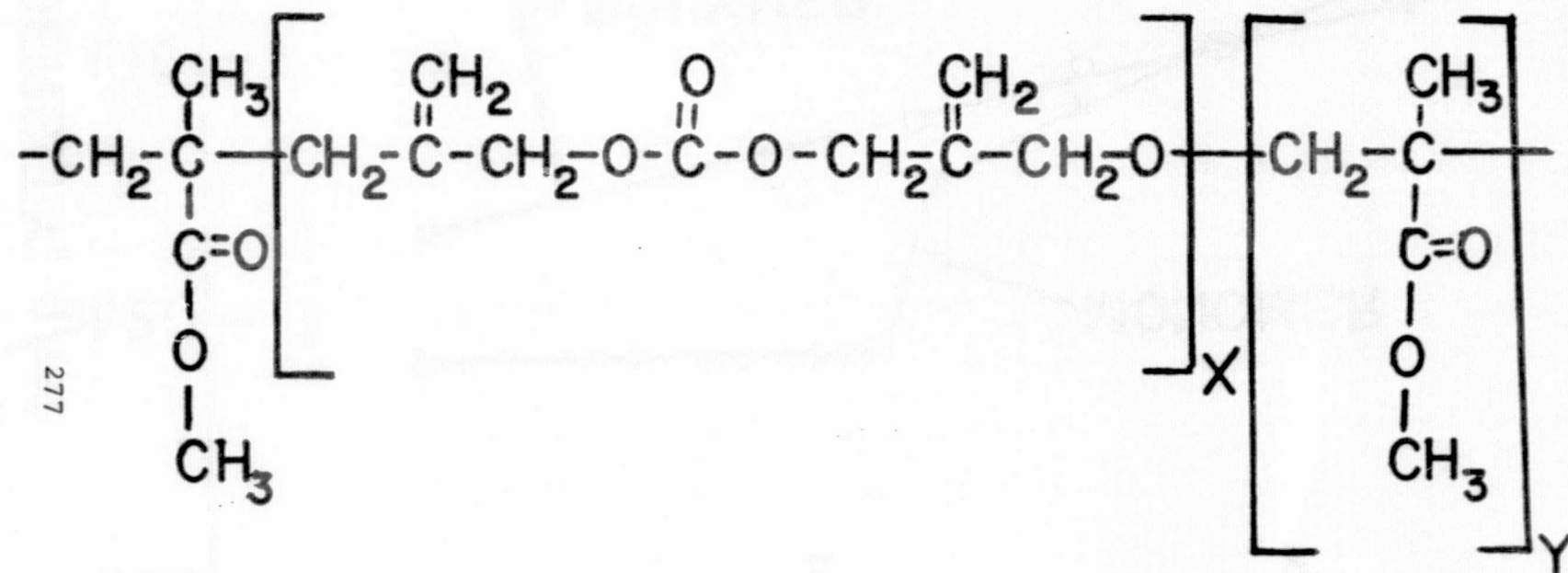
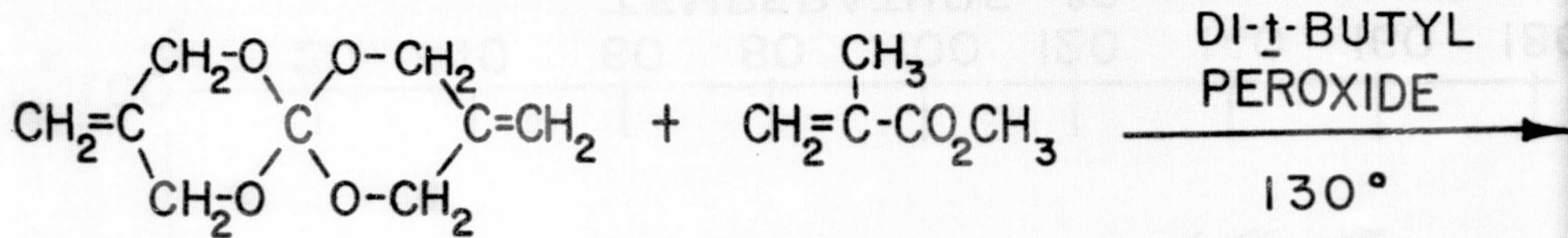

$$r_1 = 0.87 \quad r_2 = 16.4$$

AT 69% CONVERSION, 10% SPIRO MONOMER IN FEED
GIVES 1% CARBONATE IN COPOLYMER

DENSITIES OF THE MONOMERIC SPIRO ORTHO CARBONATE AND RELATED POLYOXYCARBONATE VERSUS TEMPERATURE

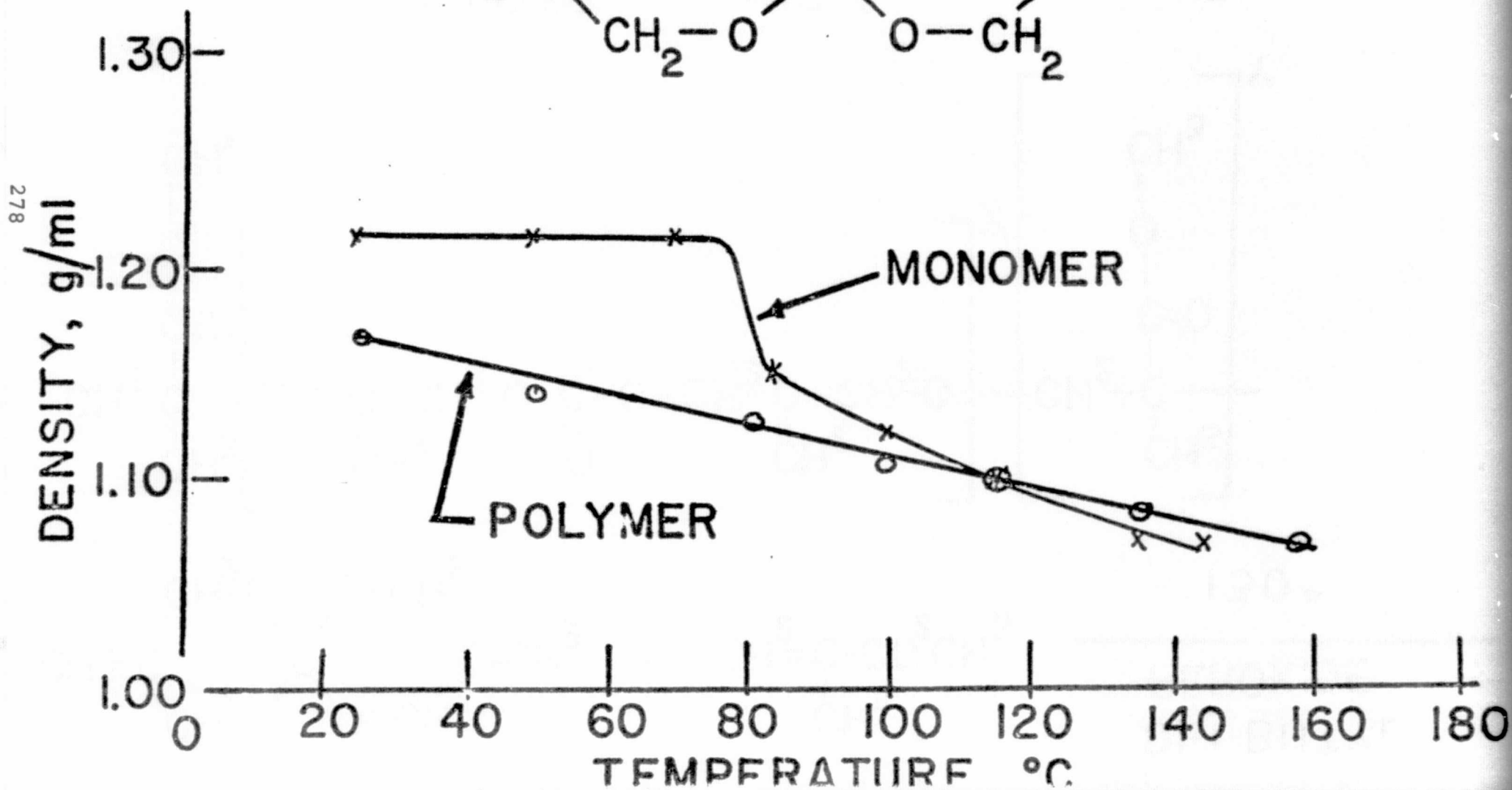
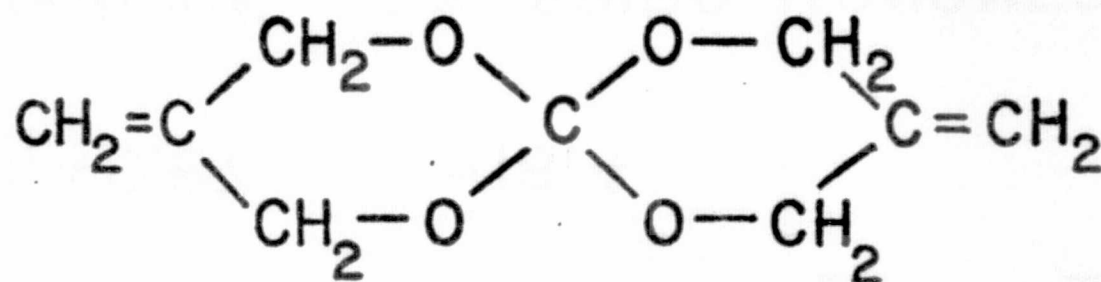

MATERIALS DEVELOPMENT REQUIREMENTS

AIRBORNE CARBON/GRAPHITE FIBERS

M. T. KATSUMOTO

BOEING COMMERCIAL AIRPLANE CO.

MARCH 23, 1978

*Mel Katsumoto
Boeing Commercial Airplane Co.*

**MATERIAL DEVELOPMENT REQUIREMENTS
AIRBORNE CARBON/GRAPHITE FIBERS**

o PHASE I NEAR TERM REQUIREMENTS

CONTINUE WITH EXISTING EPOXY AND FIBER SYSTEM

- ESTABLISH VIABILITY OF HYBRIDIZATION, VARYING WEAVE AND TAPE FORMS, APPLICATION OF SUPPLEMENTAL COATING, ETC.

o PHASE II LONG TERM REQUIREMENTS

- MODIFICATION OF CURRENT EPOXY AND FIBER SYSTEMS
- DEVELOP NEW MATRIX AND FIBER SYSTEMS

RATIONALE - PHASE I

CONTINUE WITH EXISTING EPOXY AND FIBER SYSTEMS:

- o DISPERSAL AND FRAGMENTATION PHENOMENA NOT COMPLETELY UNDERSTOOD
 - DIFFERENT WEAVE AND TAPE COMBINATION FORMS
 - HYBRID TAPE AND FABRIC
 - SUPPLEMENTAL COATING SYSTEM
- o HARDWARE COMMITMENT ON CURRENT AND PROPOSED AIRPLANES
 - COMPOSITE TECHNOLOGY JEOPARDIZED IF CONTINUITY IN COMMITMENT NOT MAINTAINED
- o LONG LEAD TIME REQUIRED-MATERIAL DEVELOPMENT TO CERTIFICATION
 - EVALUATION
 - SPECIFICATION
 - DESIGN MINIMUM OF 5-7 YEARS
 - DURABILITY
 - ALLOWABLES
 - CERTIFICATION
- o EXTENSIVE DATA BASE REQUIRED FOR AIRPLANE CERTIFICATION

TECHNICAL REQUIREMENTS

- o IF REQUIRED IMPROVE AFTER BURN PROPERTIES TO CONTROL FRAGMENTATION AND DISPERSAL OF FIBERS
- o INHERENT RESISTANCE TO AIRCRAFT FLUIDS
 - HYDRAULIC FLUIDS
 - FUEL
 - ANTI-ICING
 - ETC.
- o COMPATIBLE WITH AIRCRAFT ENVIRONMENTS
 - U. V.
 - MOISTURE
 - TEMP. (-65^o to 180^oF)
 - ETC.
- o COMPATIBILITY WITH AIRCRAFT MATERIALS
 - PAINT
 - SEALANT
 - ADHESIVES
 - ALUMINUM
 - TITANIUM
 - COMPOSITE
- o EXHIBIT COST EFFECTIVE MANUFACTURING PROCESS

MATERIALS COMPATIBILITY

PHOSPHATE ESTER HYDRAULIC FLUIDS

PROPERTIES

LOW VOLATILITY

LOW SURFACE TENSION

EXCELLENT SOLVENT

MISCIBLE WITH OTHER SYNTHETIC COMPOUNDS

PLASTICIZER (PARTICULARLY FOR POLYVINYL
TYPE RESINS)

FIRE RESISTANT

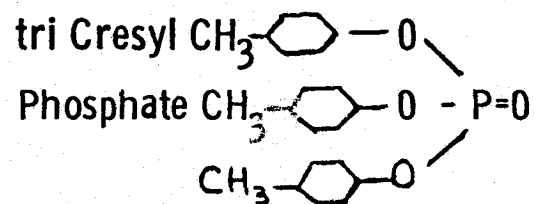
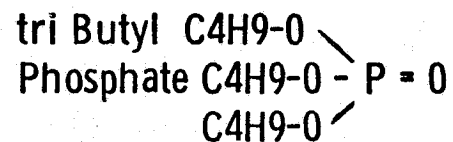
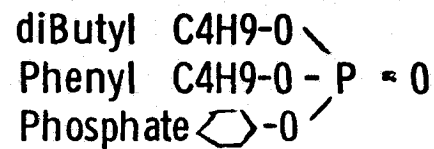

FLUID COMPATIBILITY

PERCENT SWELL - 72 HOURS AT 160°F

	PHOSPHATE ESTER HYDRAULIC FLUIDS (SKYDROL 500 TYPE)	TYPE III FUEL
NEOPRENE	150%	81%
HYPALON	250%	100%
BUTYL	7%	403%
VITON	225%	3%
POLYIMIDE	- 0.04%	
ETHYLENE PROPYLENE	4.5%	315%
EPOXY 350°F	.55%	
LARC 160	1.1%	
* POLYSULFONE	- 2.07%	
** TITANIUM	0%	

- * Unsatisfactory under stress conditions
- ** Embrittlement problems at high temperatures

RATIONAL PHASE II

- o IMPROVE ENVIRONMENTAL DURABILITY, FRACTURE TOUGHNESS & MECHANICAL PROPERTIES TO EXPAND USAGE TO PRIMARY STRUCTURE
- o IMPROVE FLAMMABILITY RESISTANCE FOR INTERIOR AND FLAME CRITICAL AREAS (FUEL TANK, POWER PLANT, APU, ETC.)
- o IMPROVE LIGHTNING STRIKE AND ELECTRICAL EFFECTS
- o IF REQUIRED IMPROVE AFTER BURN PROPERTIES TO CONTROL FRAGMENTATION & DISPERSAL OF FIBERS

PRELIMINARY TECHNICAL REQUIREMENTS - PHASE II

COMPOSITE PROPERTIES	CURRENT EPOXY SYSTEM				PHASE II PROPOSED COMPOSITE SYSTEM			
	TAPE		FABRIC		TAPE		FABRIC	
TENSILE ULT 0° RT	185		70		200		90	
TENSILE MODULUS 0° RT	18 - 21		8.5 - 11		18 - 21		9-11	
TENSILE STRAIN 0° RT	9500		7000		10000		8000	
TENSILE 90° R.T.	4.5 KSI		70		5		90	
SHORT/BEAM/SHEAR	13		7		14		8	
COMPRESSION 0°	155		70		170		80	
COMPRESSION (MODULUS)	16.5-19		7.5-10		19 - 22		16.5-19	
COMPRESSION STRAIN	8500		6800		10,000		8000	
MOISTURE RESISTANCE	+45	SBS	COMP.	SBS	+45	SBS	COMP	SBS
	Tens.				Tens.			
% RETENTION OF STRENGTH @ RT	85	75	80	80	95	95	95	95
% RETENTION @ 270F	65	55	55	50	85	85	85	85
LIGHTNING STRIKE-ELECTRICAL EFFECTS	No		No		Yes		Yes	
FLUID RESISTANCE								
FUEL	Yes		Yes		Yes		Yes	
SKYDROL	Yes		Yes		Yes		Yes	
FIBER FRAGMENTATION & DISPERSAL	NO?		NO?		Yes		Yes	
FLAMMABILITY FAR 25	NO?		NO?		Yes		Yes	

ORIGINAL PAGE
OF POOR QUALITY

286

C-4

MATERIAL DEVELOPMENT SCHEDULE

1	2	3	4	5	6	7	8
---	---	---	---	---	---	---	---

ROQMS
DEFINED

EVALUATION OF
CANDIDATES

SELECT SYSTEMS
FOR QUALIFICATION

PRELIMINARY PREP.
SPECIFICATION

QUALIFICATION
OF SUPPLIERS

SPECIFICATION
RELEASE

ALLOWABLES, ENVIRONMENTAL DURABILITY TESTING

PRELIMINARY
ALLOWABLES

UPDATED
ALLOWABLES

PROJECT DESIGN

PRODUCTION
COMMITMENT

PREPRODUCTION

FAA PREPRODUCTION
CERTIFICATION

FLIGHT TEST

FAA FINAL
CERTIFICATION

HYBRID COMPOSITES
Dr. KARL PREWO, CHAIRMAN

NAME	ORGANIZATION
Karl Prewo	United Technologies Research Ctr.
William E. Winters	TRW Equipment
John Wooley	Lockheed Calif. Co.
Harold Sanders	Grumman Aerospace
Karl Hergenrother	Transportation Systems Center - DOT
John Freche	NASA Lewis Research Ctr.
Jim McGann	Rockwell International (LAD)
Charlie King	NASA LaRC
Jim Henshaw	AVCO Specialty Materials Div.
Ashok Dhingra	DuPont
Ira Petker	Composites Horizons

NASA Reporters: A. J. Chapman and W. B. Lisagor, LaRC

ISSUES FOR
HYBRID COMPOSITES
WORKING GROUP

1. What principles would be employed by hybrid composites to retard fiber release?
2. Would metallic coatings applied to the surface of fabricated parts be effective in retarding fiber release?
3. Would intumescent coatings applied to the surface of fabricated parts be effective in retarding fiber release?
4. For each potential solution via hybridization:
 - (a) What principle would this approach employ to retard fiber release?
 - (b) What is the likely effect on the weight of fabricated parts?
 - (c) Would this approach be cost effective?
 - (d) How difficult would it be to fabricate this hybrid?
 - (e) What effect would this approach have on mechanical properties?
 - (f) What is the likely environmental durability of this hybrid as compared to graphite-epoxy?
 - (g) Are any large scale production problems likely with this hybrid?
6. What is your assessment of the current NASA research program in this area, and what changes do you recommend?
7. Rank the generic solutions (fiber modifications, fiber coatings, alternative fibers, epoxy resin modifications, epoxy resin replacements, hybrid composites) as to their probability of success.

NASA REPORTERS' SUMMARY FOR HYBRID
COMPOSITES WORKING GROUP

Prior to the general working group discussions, Ashok Dhingra presented a prepared review of DuPont's Kevlar and FP (Al_2O_3) fiber development (see Coatings Section for copy of visual aids). These fibers are being advanced as possible replacements for graphite or for use in hybrid laminates.

The working group focused mainly on ways to contain the graphite fibers and prevent their dispersion to the environment following damage, fire or explosion. The particular hybrid systems discussed included metallic surface layers, third material additives, intumescent coatings, outer composite envelope, multiple fiber hybrids, and resin hybridization.

Metallic Surface Layers.- Metal foils or wire mesh may be applied to composite surfaces to prevent graphite fiber dispersion by maintaining surface integrity. Such surfaces are presently incorporated in some composites for lightning damage protection, and they do not involve critical modifications to the basic composite. Disadvantages include the possibility that the metal surfaces would not be effective in case of extreme damage, and may cause distortion during laminate fabrication.

Third Material Additive.- Structurally passive particulate or fibrous additives may prevent dispersion of graphite fibers in case of fire by melting and fusing over the fibers. Such additives include a glass fiber screen or weave, glass microballoons or solid particles, and a fiber "serving" or coating. This approach would require minimum changes in the matrix and in processing, and may require only minimum requalification of the composite. However, laminate density would be increased and specific properties would be decreased. The additives may contribute to fiber damage in normal service.

Intumescent Coatings.- An organic coating (~ .03") may be applied to the composite surface to minimize dispersion of graphite fibers in the event of damage and fire. Such coatings may be an immediate quick-fix for existing composite components and, although not a complete solution, these coatings may enable the continuation of existing composite flight programs. Apparent disadvantages of intumescent coatings include additional weight and short service life. It was also agreed that it would be difficult to keep the coating on.

Outer Composite Envelope.- Structurally active outer composite plies may be used to contain inner graphite fiber plies in the event of fire and damage. The outer plies would consist of fire resistant fibers in a high char forming resin matrix. This approach has the advantage of adding a structurally active part to the composite rather than passive weight. Possible disadvantages may include compatibility with graphite plies, weight, and cost.

Multiple Fiber Hybrids.- Non-conducting fibers may be used in combination with graphite to reduce the amount of conducting fibers released by a fire to some acceptable level. This approach would have the advantage of retaining many of the superior properties of graphite fibers, while possibly gaining some unique properties from a new fiber. For example, high modulus - low strength fibers would be combined with low modulus - high strength fibers. Laminates could be designed for ply combinations using various fibers.

Resin Hybridization.- This approach would involve distributing layers of different resin systems throughout the laminate. Most of the discussion centered on high char yield resins. Discrete layers of high char forming resin would be distributed between conventional plies throughout the laminate. In the event of fire, the resulting char may adhere to graphite fibers retarding their dispersion. After some consideration, this approach did not seem too attractive; inclusion of such layers would probably lower fiber content, degrade mechanical properties, and require a new data base. Using a high char forming resin matrix throughout the composite appeared to be a better approach but would not be classified as a hybrid composite.

CONCLUSIONS

1. Hybridization is the only reasonable approach for a near term solution to the graphite fiber problem.
2. Significant changes in the graphite/epoxy system would destroy the utility of the data base and would require new material qualification programs.
3. Replacement of graphite fibers would result in inferior mechanical properties and replacement of the epoxy would reduce the efficiency of the composite. The advantages of composites would be destroyed.

4. Metallic coatings for containing fibers are probably not satisfactory.
5. Glass cloth or fiber outer layers may offer the most promise for preventing release of graphite fibers.

RECOMMENDATIONS

1. Promising solutions should be implemented in the short term to maintain impetus of existing programs avoiding disassumptions which could jeopardize program support.
2. Standardized tests must be developed to define the graphite fiber hazard potential as well as to evaluate potential fixes.
3. The hazard potential must be evaluated with respect to various aircraft zones (structure, systems, engines, etc.).
4. Continue research on long term optimum solutions while implementing short term solutions.
5. Long term solutions should consider epoxy resin replacement, alternate or modified fibers, new hybrids.

REPORT OF
HYBRID COMPOSITES
WORKING GROUP

DR. KARL PREWO, CHAIRMAN

HYBRID COMPOSITES

ISSUES CONSIDERED

- 0 FIND SOLUTION THAT CAUSES MINIMUM DISRUPTION OF
EXISTING TECHNOLOGY BASE

- 0 LONGER TERM SOLUTION

INTUMESCENT COATING

APPROACH

USE AN ORGANIC COATING THAT MINIMIZES THE LIKELIHOOD OF BURNING AND ALSO THE ESCAPE OF GRAPHITE FIBERS.

ADVANTAGES

- o VERY QUICK FIX
- o CAN BE APPLIED TO EXISTING COMPONENTS

DISADVANTAGES

- o WEIGHT PENALTY
- o SHORT SERVICE LIFE

METALLIC SURFACE LAYERS

APPROACH

PREVENT FIBER ESCAPE BY MAINTAINING SURFACE INTEGRITY

- o METAL FOIL OR WIRE MESH
- o METALLIZED GLASS FIBERS

296

ADVANTAGES

- o MAY ALREADY BE DESIGNED IN
- o MEETS LIGHTNING PROTECTION REQUIREMENTS
- o NO COMPOSITE MODIFICATION
- o IMPROVED IMPACT TOLERANCE

DISADVANTAGES

- o EXTREME DAMAGE MAY OVERCOME
- o MAY CAUSE DISTORTION

THIRD MATERIAL ADDITIVE

APPROACH

PREVENT ESCAPE OF GRAPHITE THROUGH USE OF PARTICULATE OR FIBROUS ADDITIVE WHICH IS PASSIVE EXCEPT IN THE CASE OF FIRE

- o GLASS FIBERS - SCRIM - "UNIWEAVE"
- o FIBER "SERVING"
- o MICROBALLOONS OR SOLID PARTICULATE

ADVANTAGES

- o MINIMUM REQUALIFICATION
- o MINIMUM CHANGE IN MATRIX AND PROCESSING
- o NO CHANGE IN FIBER

DISADVANTAGES

- o INCREASED WEIGHT
- o FIBER DAMAGE

OUTER COMPOSITE ENVELOPE

APPROACH

USE "ACTIVE" OUTER COMPOSITE LAYERS AS CONTAINMENT.

- o HIGH CHAR FORMING RESIN MATRIX PLIES
- o FIRE RESISTANT FIBERS IN OUTER PLIES
(E.G. B, GLASS)

ADVANTAGES

- o CONTRIBUTES STRUCTURALLY

DISADVANTAGES

- o COST PENALTY
- o WEIGHT PENALTY

MULTIPLE FIBER HYBRIDS

APPROACH

USE NON CONDUCTING FIBERS IN COMBINATION WITH OR WITHOUT GRAPHITE FIBERS

ADVANTAGES

- o SOME FIBERS CURRENTLY AVAILABLE
- o UNIQUE PAY OFFS (TOUGHNESS)

DISADVANTAGES

- o REQUIRES REDESIGN
- o INCOMPLETE KNOWLEDGE OF FAILURE MECHANISMS
- o INFERIOR SPECIFIC PROPERTIES MAY NOT BE ACCEPTABLE

RANKING OF GENERIC SOLUTIONS

<u>SOLUTION</u>	<u>% PARTICIPANTS FAVORING</u>
HYBRIDS	40
EPOXY MODIFICATION	15
"EXISTING" REPLACEMENT RESINS	15
FIBER MODIFICATIONS	10
FIBER COATINGS	10
ALTERNATE FIBERS	10

RECOMMENDATIONS

- 0 FIND PROMISING SOLUTIONS IN THE SHORT TERM TO MAINTAIN COMPOSITE IMPETUS
- 0 HYBRIDS OFFER BEST OPPORTUNITY TO ACHIEVE THIS
- 0 NEED REPRESENTATIVE TESTS THAT CAN BE STANDARDIZED
- 0 ZONE HAZARD LEVELS OF AIRCRAFT AND ENGINES
- 0 LOOK FOR LONG TERM SOLUTION - ALTHOUGH SHORT TERM MAY SUFFICE
- 0 MAINTAIN VISIBILITY

FIBER RELEASE SIMULATION TESTING

E. Bruce Belason, Chairman

NAME	ORGANIZATION
Raymond Foye	U.S. Army R&T LABS
T. C. Grimm	McDonnell Aircraft Co.
Robert E. Sanders	Rockwell International - Tulsa
Frank Riel	Rohr Industries, Inc.
H. C. Schjelderup	Douglas Aircraft Co.
Richard Tracy	Lear Avia Corp.
William J. Snyder	Bucknell University
Joe Mansfield	NASA Ames
Vernon Bell	NASA LaRC
Bill Brooks	NASA LaRC
Tito Serafini	NASA Lewis
Bruce Belason	AVCO Specialty Materials Div.
Wolf Elber	NASA LaRC
Joseph Reardon	Naval Res. Lab
Ken Musselman	Naval Surface Weapons Ctr (Dahlgren)
Edward Lopez	Lockheed Calif.
John McFerrin	Union Carbide
John Parker	NASA Ames
James Peterson	Boeing Commercial Airplane Co.
Guilio Varsi	JPL
Dell Williams	NASA Headquarters
Bob Schaffer	HITCO Defense Products
NASA Reporters:	Robert Jewell and Don Rummel, LaRC

**ISSUES FOR
FIBER RELEASE SIMULATION TESTING
WORKING GROUP**

1. Can fiber release testing be realistically simulated?
2. What procedure do you recommend for laboratory scale testing? Are there alternative procedures? What are the advantages and disadvantages of each?
 - (a) How should we conduct laboratory tests to reproduce the effects of fire and explosion on coated or treated fibers?
 - (b) How should we screen the fiber release characteristics of hybrids or new resins in the laboratory?
3. What quick, relatively inexpensive, large scale tests can be used to screen resin modifications and hybrids for effectiveness in reducing fiber release?
4. What procedure do you recommend for large or full scale qualification testing? Are there alternative procedures? What are advantages and disadvantages of each?
5. What test temperatures, oxidation rates, burning times, smoke generation rates, flame oxygen content, and fiber dissemination procedures should be used in a simulation facility?
6. What are reasonable and appropriate specimen sizes, shapes, resin contents for each scale of testing?
7. What inputs are needed from risk analysis to evaluate the effectiveness of materials modifications?

NASA REPORTERS' SUMMARY FOR FIBER RELEASE
SIMULATION TESTING WORKING GROUP

The meeting was prefaced with 5 presentations given by Jim Peterson (Boeing), Bruce Belason (AVCO), Joe Reardon (NRL), Giulio Varsi (JPL) and Joe Mansfield (NASA-Ames). The working group's deliberations are summarized in three parts according to the particular test parameter: burn conditions, fiber release mechanisms, and measurements on released fibers.

Burn conditions.- A concensus was reached on (a) the urgent need to establish a set of laboratory test procedures, and (b) the urgent need for risk analysis studies. The risks associated with release of graphite fibers in an aircraft accident are ill-defined. Bounds establishing the nature of a reasonable threat are needed as initial guidelines for selecting testing parameters.

For the composite materials in present use, the effects of variations in test temperature, flame oxygen content, heat flux, and other parameters should be determined and documented. It was agreed that NASA should take the lead in developing simulated test methods. Detailed issues, such as appropriate specimen geometry, types of large-scale tests, and methods for testing specific materials, e.g., hybrid laminates or composites composed of coated or treated fiber, were not discussed.

Fiber release mechanisms.- In the combustion of the composite material, the matrix resin is burned, with no fiber release occurring. Fiber dispersal requires some form of agitation during or after combustion.

Fiber release by detonation of an explosive charge is a violent method, tending to distort test results. Dissemination of fibers by mechanical vibration, by air currents or air blasts, by falling or swinging weights, and by other projectiles are some alternative methods. The working group did not select a preference.

Laboratory test methods are needed to simulate the effects of a large scale fire phenomena. Then, test methods to adequately simulate fiber release could be developed. A description of the thermal/physical environment (scenarios) considered most relevant to the problem is critically needed in order to select test parameters.

Measurements on released fibers.- Laboratory simulation of the burn and fiber release is not the main problem.

Methods and/or instruments for collection of meaningful data on fiber release represent a true bottleneck. Those now testing yearn for a "fiber dosimeter." Measurements of fiber release phenomena at present are rudimentary and crudely qualitative. Meaningful testing must discern fiber geometries and their distribution, fiber quantities, and fiber electrical properties. Applicable test methods and instrumentation are needed.

CONCLUSIONS

1. A set of laboratory test procedures is urgently needed. However, selection of suitable test conditions requires inputs from risk analysis as well as parametric data for various burning and impact conditions.
2. Further definition of the risk resulting from the carbon fiber hazard is necessary before companies will take strong independent roles in testing. In the meantime, NASA must play a major role in guiding and financing development in this area.

RECOMMENDATIONS

1. A working group of reasonable and effective size should be established to develop test methods and procedures. NASA should be charged with this duty.
2. The participants strongly suggested that the aircraft industry will not address problems associated with the accidental release of graphite fiber unless the problem area is more competently defined. The participants indicated that definition of the threat should be an NASA activity.

REPORT OF
FIBER RELEASE SIMULATION TESTING
WORKING GROUP

E. BRUCE BELASON, CHAIRMAN

FIBER RELEASE SIMULATION TESTING

(Continued)

5.) TEST FACILITIES AND TECHNIQUES FOR THE ABOVE:

STATUS	SMALL SCALE	LARGE SCALE	IF DEV'T IS REQUIRED:	
			COST	TIME
EXISTING				
EXISTING, BUT REQUIRE MOD.	X	X ?		3 MOS.
MUST BE BUILT (OR DEVELOPED)				

308

6.) RISK ANALYSIS INTERFACE: INPUTS REQUIRED

OUTPUTS REQUIRED

MATERIALS SCREENING TEST
(CONSENSUS)

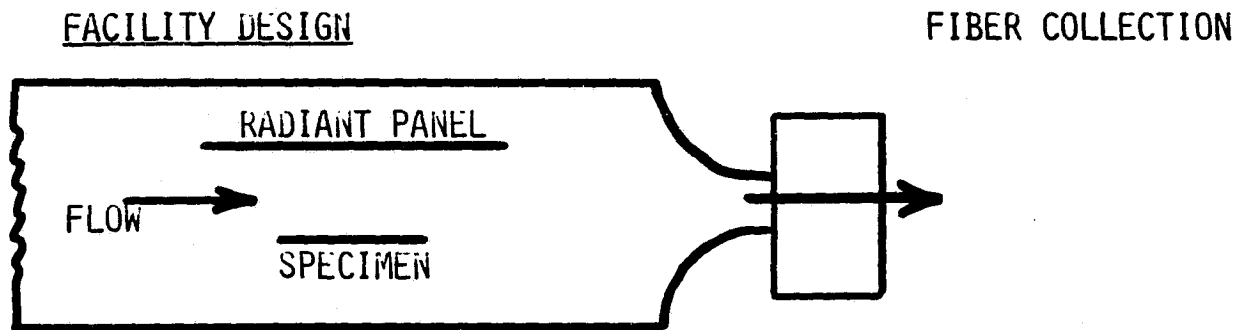

TEST CONCLUSIONS TO DATE:

IN CURRENT GRAPHITE/EPOXY, RESIN BURNS OUT QUICKLY (3 MINUTES),
LEAVING FIBERS WHICH APPEAR TO BE READILY REMOVABLE IF MECHANICALLY
PERTURBED.

EXPERIMENTAL NEEDS:

- 1.) IMPROVED DIAGNOSTICS FOR FIBER RELEASE MEASUREMENT.
- 2.) CORRELATION OF MEASURED FIBER RELEASE TO REAL LIFE ENV'TS.

UNRESOLVED:

WHETHER TO INCORPORATE MECHANICAL PERTURBATION AND IF SO, WHAT TYPE?

ACTION RECOMMENDED:

NASA TO FORM A WORKING GROUP

RISK ANALYSIS TEST

TEST FACILITY DESIGN

- o LARGER SPECIMENS (VS SCREENING TEST)
- o VARIOUS SHAPES
- o VARIOUS MECHANICAL IMPACTS (SIMULTANEOUS TO FIRE EXPOSURE)
- o INCORPORATE FIBER RELEASE DIAGNOSTICS
- o RESULTS MUST BE EXTRAPOLATABLE TO RELIABLY ANALYZE POTENTIAL ACCIDENT SCENARIOS.

320

OTHER FACTORS/CONSIDERATIONS

- o RISK ANALYSIS MUST CONSIDER WHAT PARTS OF AIRPLANES ARE TO USE COMPOSITES AND IN WHAT FORM, AND WHAT TYPE OF FIRE SCENARIO(S) THIS COMPONENT CAN LIKELY SEE.
- o FIBER TRANSPORT (AFTER RELEASE) MUST BE DETERMINED
- o CRITICAL FIBER SIZES MUST BE BETTER DEFINED
- o CREDIBILITY GAP EXISTS

FIRE AND IMPACT TESTING

JOE MANSFIELD (ARC)

MARCH 23, 1978

311

TESTS CONSIDERED

SCREENING

SIMULATION

TEST PARAMETERS
CONSIDERED

REALISM OF FIRE EXPOSURE

REALISM OF MECHANICAL EXPOSURE

REALISM OF SAMPLE CONFIGURATION AND
SUPPORT MECHANISMS

TEST TIME REQUIREMENTS

COSTS OF MANUFACTURE AND OPERATION

TEST PROGRAM LISTING

SMALL-SCALE SCREENING TESTS

MODIFIED CHARPY IMPACT (BURNING SAMPLES)

STANDARD MECHANICAL TESTS (UNBURNED SAMPLES)

TENSILE

FLEXURE

CHARPY IMPACT (UNMODIFIED)

LABORATORY FLAMMABILITY TESTS
& LIMITING OXYGEN INDEX

SIMULATION TESTS

PROJECTILE IMPACT

~ 30 FT/SEC

50 - 400 FT/SEC

SHOCK WAVE EXPOSURE

HIGH VELOCITY FLOW EXPOSURE

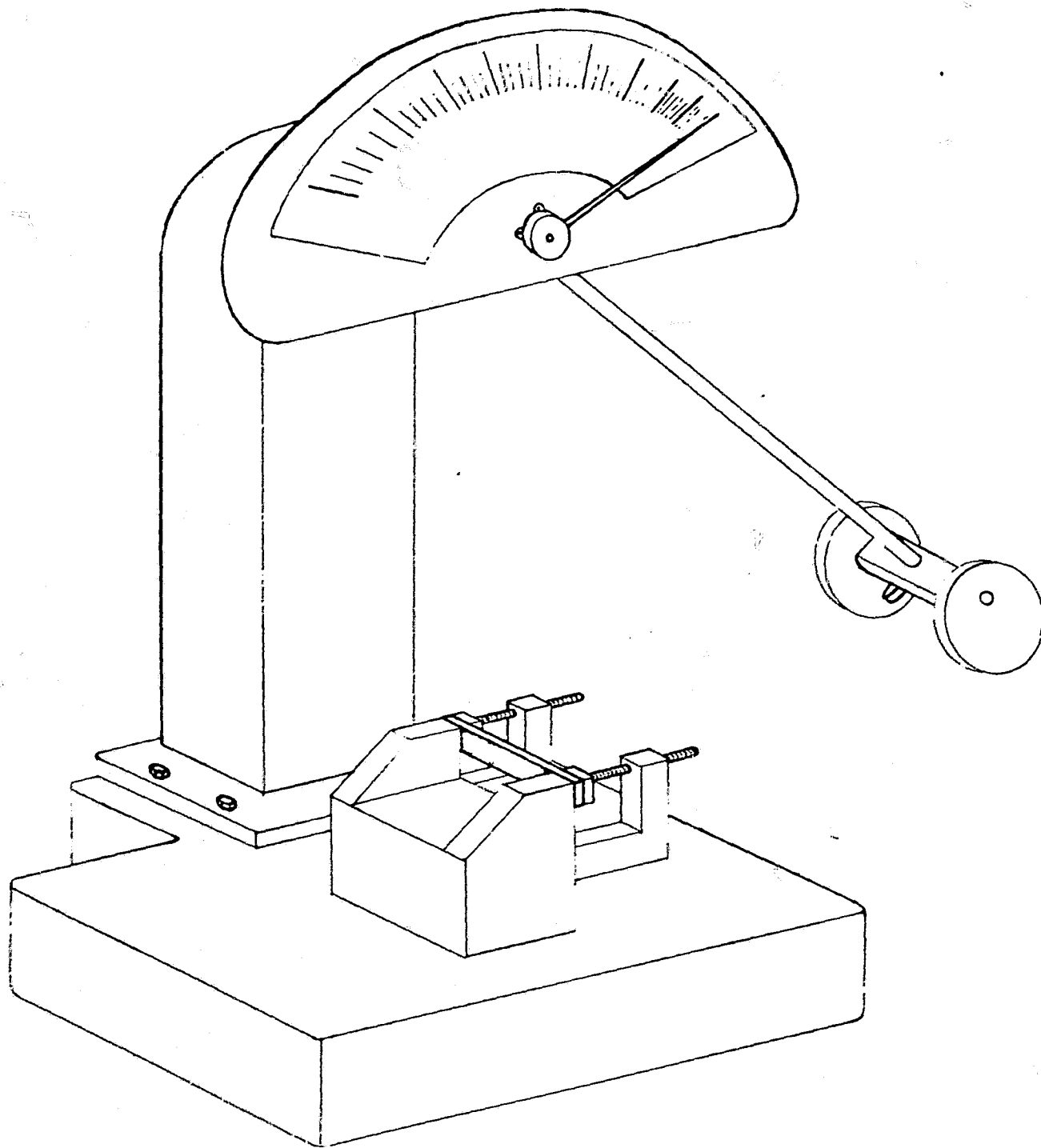

VENT AND FILTER
SYSTEM

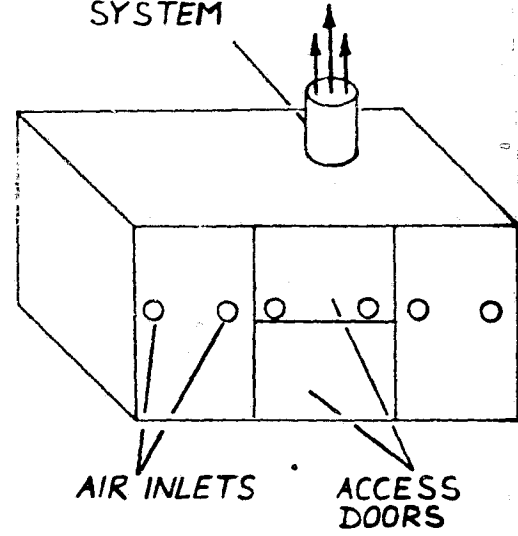

315

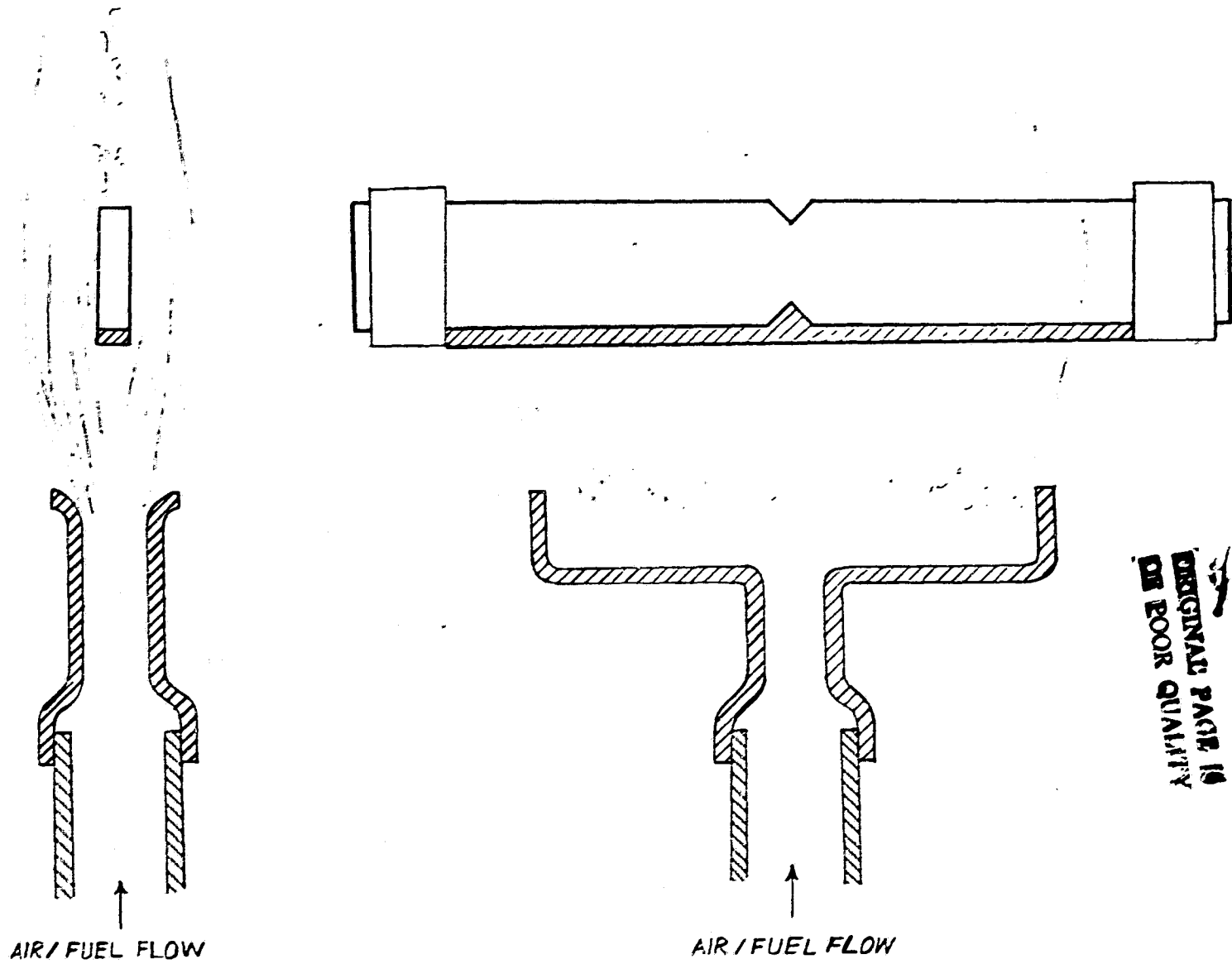

ORIGINAL PAGE IS
OF POOR QUALITY

CHARPY TEST BURNER CONFIGURATION

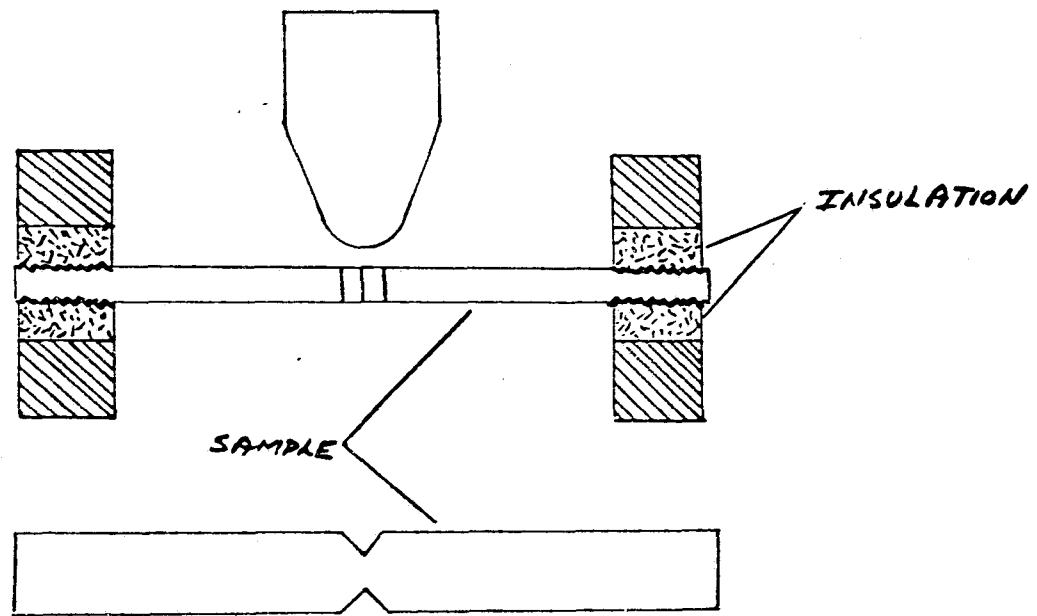
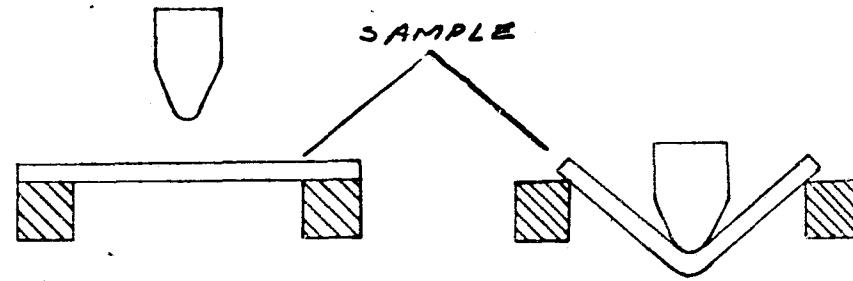

CHARPY TEST SAMPLE AND SAMPLE SUPPORT MECHANISM

317

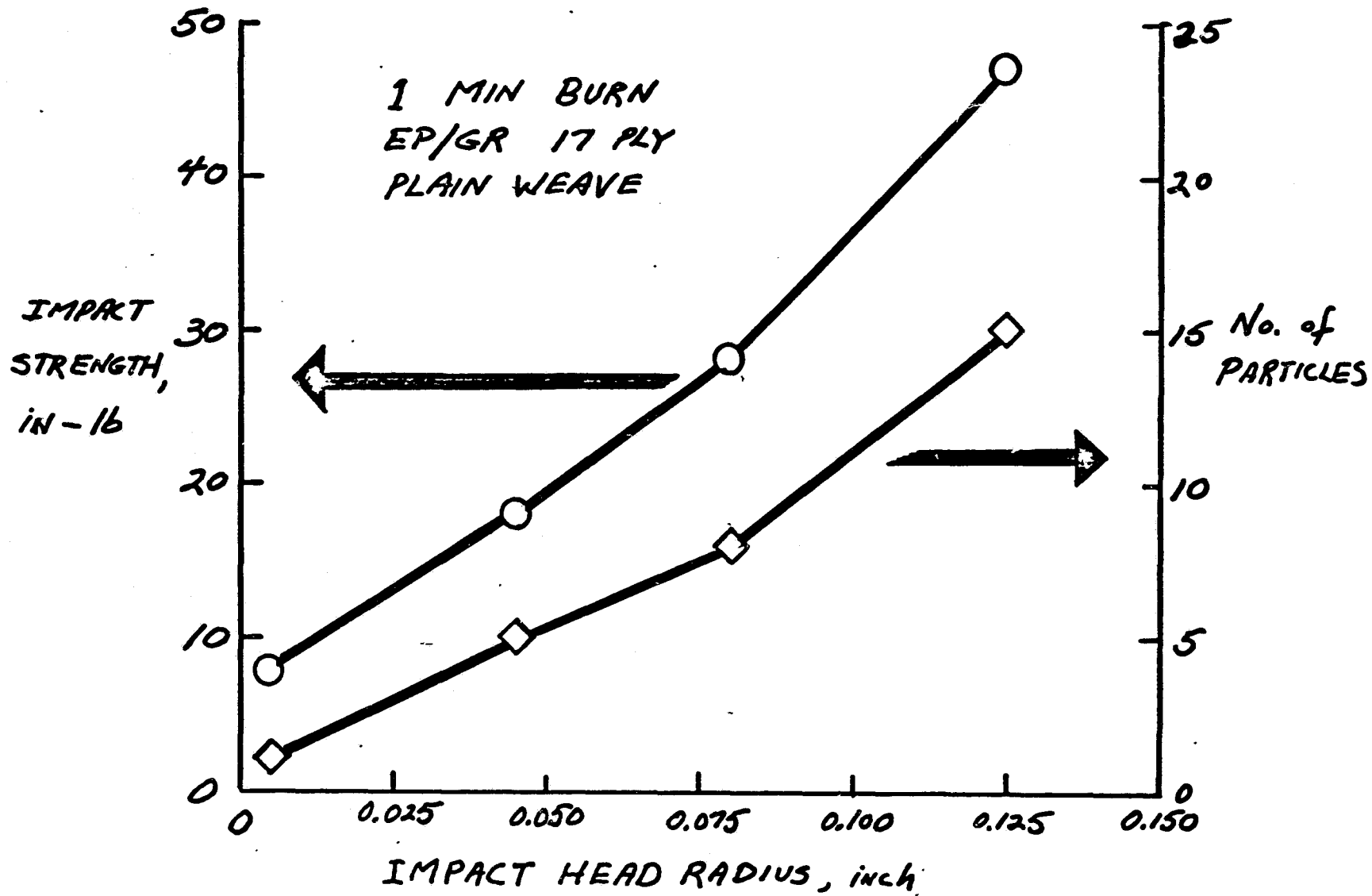

RECOMMENDED SPECIFICATIONS FOR
CHARPY IMPACT TEST

SAMPLE THICKNESS ~ .12"
SAMPLE WIDTH AT NOTCH ~ .20"
IMPACT HEAD RADIUS .125"

IMPACT ARM WEIGHT 200 IN-16
FUEL PROPANE
FUEL FLOW RATE
AIR FLOW RATE

VENT RATE DURING BURNING 10 CFM
VENT RATE AFTER BURNING 50 CFM
BURN TIME VARIABLE

MODIFIED CHARPY SCREENING TEST

ADVANTAGES

- TEST BOTH DURING AND AFTER BURNING
- USE COMMERCIAL INSTRUMENT WITH MINOR MODIFICATION
- USE SMALL AND EASILY FABRICATED SAMPLE
- REASONABLY SMALL TESTING TIME

DISADVANTAGES

- DOES NOT COVER FULL RANGE OF MECHANICAL EXPOSURES
- DIFFICULT TO FULLY SIMULATE FIRE EXPOSURE
- REQUIRES FAIRLY EXTENSIVE REPLICATION

320

IMPACT
PROJECTILE
(1.5 lb)

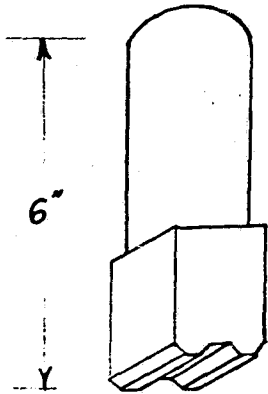

ORIGINAL PAGE IS
OF FOUR QUARTERS

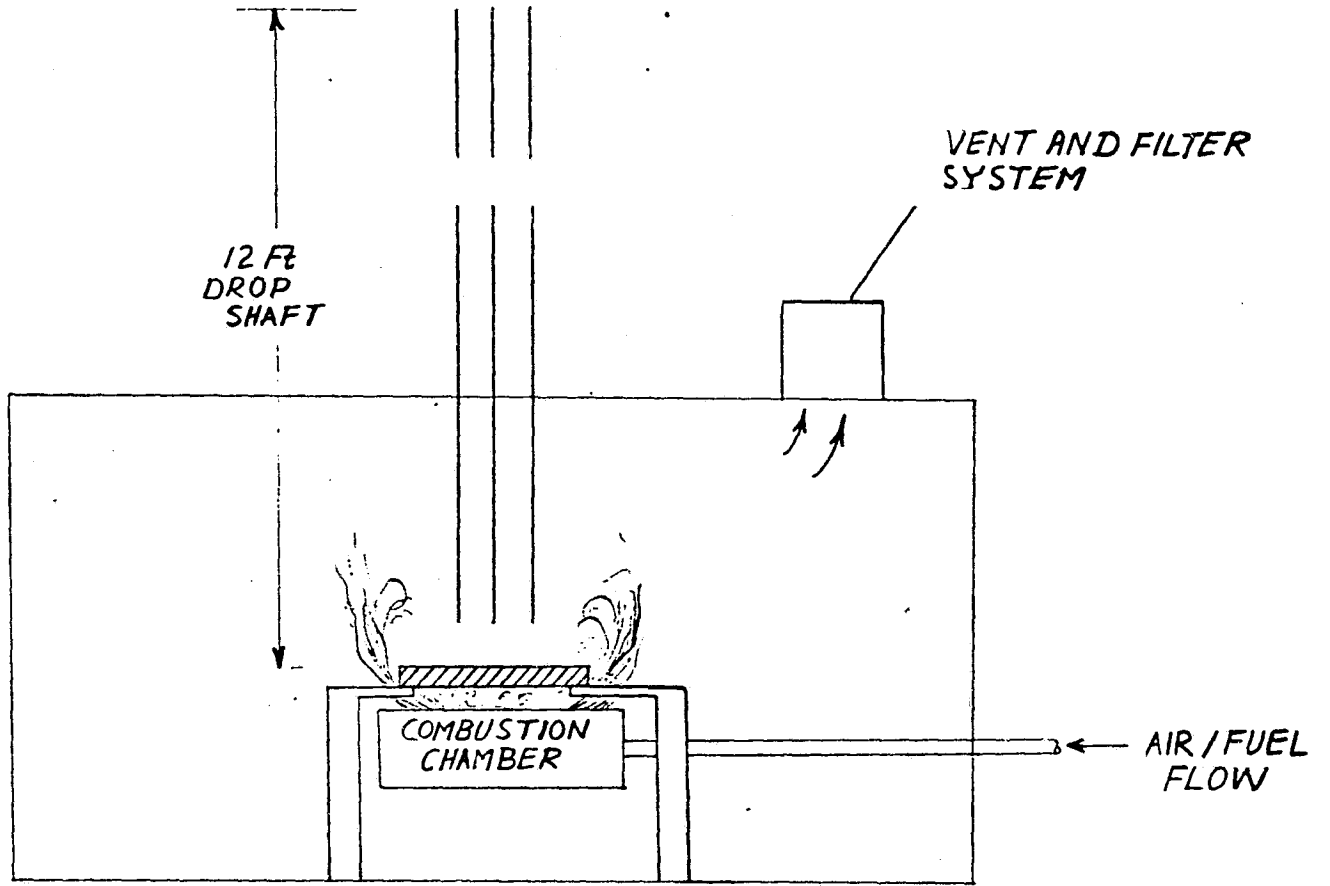

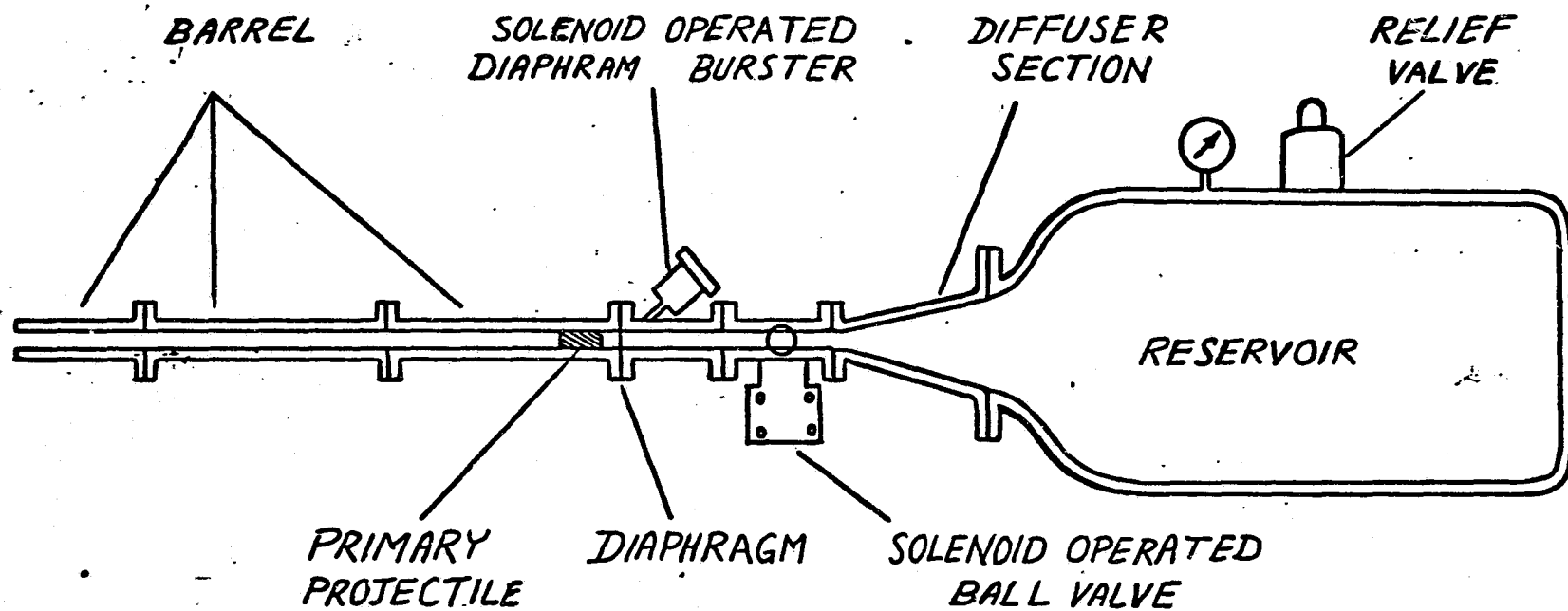

322

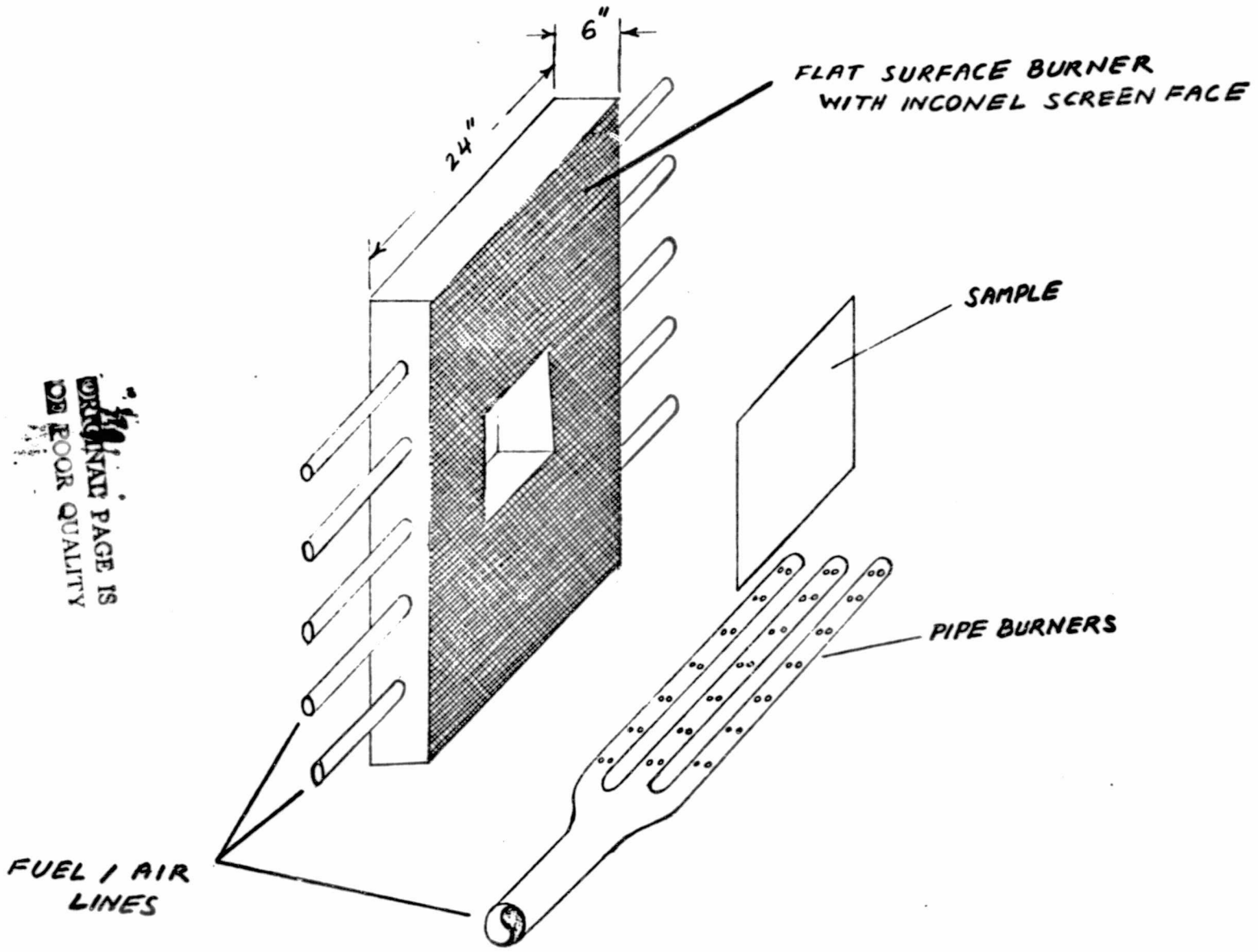

BURNER CONFIGURATION FOR SIMULATION TEST

FIBER RELEASE SIMULATION TESTING

JAMES M. PETERSEN

BOEING COMMERCIAL AIRPLANE CO.

MARCH 23, 1978

ABSTRACT

Fiber Release Simulation Testing

James M. Peterson; Boeing

The level of risk involving current technology graphite/epoxy hardware on commercial aircraft, due to the "floating fiber" phenomenon, has not been established. Resolving this question must be done by a systematic study that addresses the probability that the hardware is involved in a fire resulting in the release of fibers, that the fire is near a site housing vulnerable electrical components, and that loss or damage occurs due to any resulting electrical failure.

The type of thermal/physical environment that can result in substantial fiber release must be understood before a risk assessment can be made. Available files containing accident data should be utilized to determine the historical frequency of accidents in which composite hardware, had it been present, might have been involved. The pre-, during, and post-fire parameters that affect fiber release must be defined and evaluated. Appropriate laboratory test methodology is needed for research and development that can simulate the effects of large scale fire phenomena on fiber release, and on the subsequent transport of the fibers away from the fire site.

GRAPHITE/EPOXY HARDWARE ON COMMERCIAL AIRPLANES

LEVEL OF RISK HAS NOT BEEN ESTABLISHED

PARAMETERS (PROBABILITIES) AFFECTING RISK

o AIRCRAFT ACCIDENT OCCURENCE

o FIRE INVOLVED

o GRAPHITE COMPOSITE INVOLVED IN FIRE

o FIRE/PHYSICAL ENVIRONMENT CAUSES FIBER RELEASE

o RELEASED FIBERS TRANSPORTED FROM FIRE SITE

**o VULNERABLE ELECTRICAL COMPONENTS IN TRANSPORTED
FIBER PATH**

o ELECTRICAL FAULTING OR FAILURE OCCURS

o LOSS RESULTS FROM FAULT OR FAILURE

DEVELOPMENT OF OCCURRENCE DATA AND REPRESENTATIVE AIRCRAFT ACCIDENT/FIRE DAMAGE SCENARIOS

OBJECTIVE:

- 1. Establish the probability of aircraft accidents involving fires, composite structure and composite part damage based on accident data and composite materials usage forecasts.**
- 2. Develop scenarios based on accident histories to provide representative fire, intensity and duration, structural involvement, structural damage, additional damage aspects such as explosion or fire fighting.**

REQUIRED OUTPUT:

- 1. Probability of occurrence of representative conditions**
- 2. Series of representative scenarios**
- 3. Representative test conditions**

DATA SOURCES:

- 1. Accident statistics files (NTSB & Others)**
- 2. Accident reports**
- 3. Accident investigator statements**
- 4. Photo records of accidents**

ESTABLISHMENT OF TEST METHODOLOGY REQUIRES

- o DEVELOPMENT OF OCCURRENCE DATA AND REPRESENTATIVE AIRCRAFT ACCIDENT/FIRE DAMAGE SCENARIOS**
- o DETERMINATION OF CONDITIONS IN FIRE ENVIRONMENT IN SCENARIO:**
- o ESTABLISHMENT OF SMALL SCALE TESTS THAT REPRODUCE CONDITIONS IN LARGE SCALE FIRES**

327

**ORIGINAL PAGE IS
OF POOR QUALITY**

DETERMINATION OF CONDITIONS OF FIRE ENVIRONMENT IN SCENARIOS

OBJECTIVE: Establish the fire environment in scenarios based on fire intensity, duration, ventilation, etc. To determine parameters needed for design representative tests.

REQUIRED OUTPUT:

Representative test conditions

DATA SOURCES:

1. Accident statistics files (NTSB & Others)
2. Accident reports
3. Data from Large-Scale experimental fire test

**ESTABLISHMENT OF SMALL SCALE TEST METHODOLOGY TO SIMULATE
CONDITIONS IN LARGE SCALE FIRES**

OBJECTIVE: Establish small scale test apparatus, conditions, and procedures that can be utilized to assess the effects of large scale fires on composite materials.

REQUIRED OUTPUT:

1. Test apparatus and methodology

DATA SOURCES:

1. Current fire R&D pertaining to aircraft
2. Standard reference works

REQUIRED MATERIALS PARAMETERS FROM TESTS FOR RISK ASSESSMENT

- o AMOUNT OF FIBER RELEASED
- o RELEASED FIBER PHYSICAL CHARACTERISTICS
 - o SINGLE, MULTIPLE
 - o LENGTH.
- o RELEASED FIBER ELECTRICAL CHARACTERISTICS

**DEVELOP ENTRAINMENT, REENTRAINMENT, TRANSPORT DATA
AND RELATE TO POTENTIAL PROBLEM SITES**

OBJECTIVE:

1. Using the characteristic fiber release develop entrainment models and assumptions-generate entrainment data.
2. Using the characteristic fiber release develop reentrainment models and assumptions-generate reentrainment data.
3. Identify and select representative transport models with appropriate assumptions.
4. Identify representative potential problem sites.

REQUIRED OUTPUT:

1. Tabulation of entrainment, reentrainment data for characteristic fibers.
2. Selected transport model with assumptions.
3. Characteristic potential problem sites-accident aircraft, other aircraft, air control equipment, community locations.

DATA SOURCES:

1. Standard entrainment, reentrainment models
2. Standard transport models
3. Standard reference works

FIRE TESTING OF GRAPHITE-EPOXY
COMPOSITES IN AVCO'S MODEL 25
FIRE TEST FACILITY

By

E. Bruce Belason

Avco Specialty Materials Div.

March 23, 1978

NASA Langley Composites Workshop

TYPICAL THERMAL CONDITIONS IN FREE-BURNING

HYDROCARBON POOL FIRES

FIRE CONDITION	TEMPERATURE, °F	HEAT FLUXES, BTU/FT ² SEC		
		\dot{q}_R , Radiative	\dot{q}_c , Convective	\dot{q}_T , Total
1.) SMALL FIRE, OR, CLOSE TO GROUND IN LARGE FIRE	~ 1800°F	~ 10	~ 1-2	11-12
2.) LARGE FIRE, ESPECIALLY AT HIGHER LEVELS	1800-2000°F	~ 10	8-10; PULSES TO ~ 25	18-20

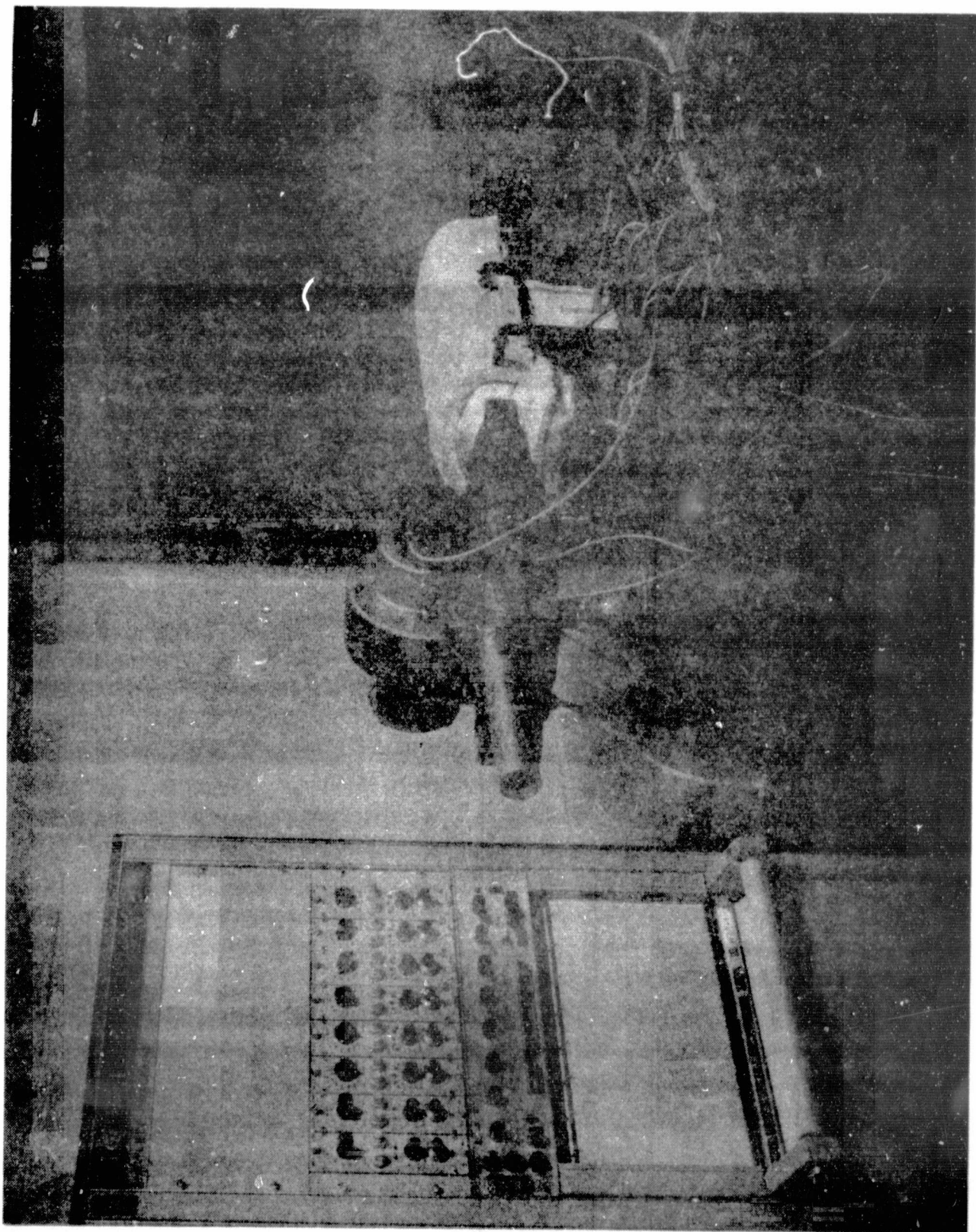

FIRE SIMULATION FACILITY

- A CRYSTOLON (SIC) MUFFLE - 7.2"D x 21.6"L
- B KANTHOL HEATER ELEMENTS - (2) 0.086 th
- C KANTHOL END HEATERS (2)
- D MULTI-FOIL INSULATION
- E CRYSTOLON (SIC) BOTTOM PLATE
- F SPECIMEN HOLDER ASSEMBLY
- G SPECIMEN POSITIONING MOTOR ASSEMBLY
- H AUTOMATIC SPECIMEN POSITION CONTROLLER
- I FLAME TEMPERATURE THERMOCOUPLE
- J SPECIMEN POSITION SENSOR
- K RADIANT SOURCE TEMP. MONITOR & CONTROLLER SENSOR
- L SPECIMEN SURFACE TEMPERATURE MONITOR
- M OIL BURNER
- N CERAMIC FLAME SHAPER
- O OIL FLOW METER
- P AIR FLOW METER
- Q 8 CHANNEL RECORDER
- R EXHAUST HOOD
- S HEAT EXCHANGER
- T CONTROL CONSOLE

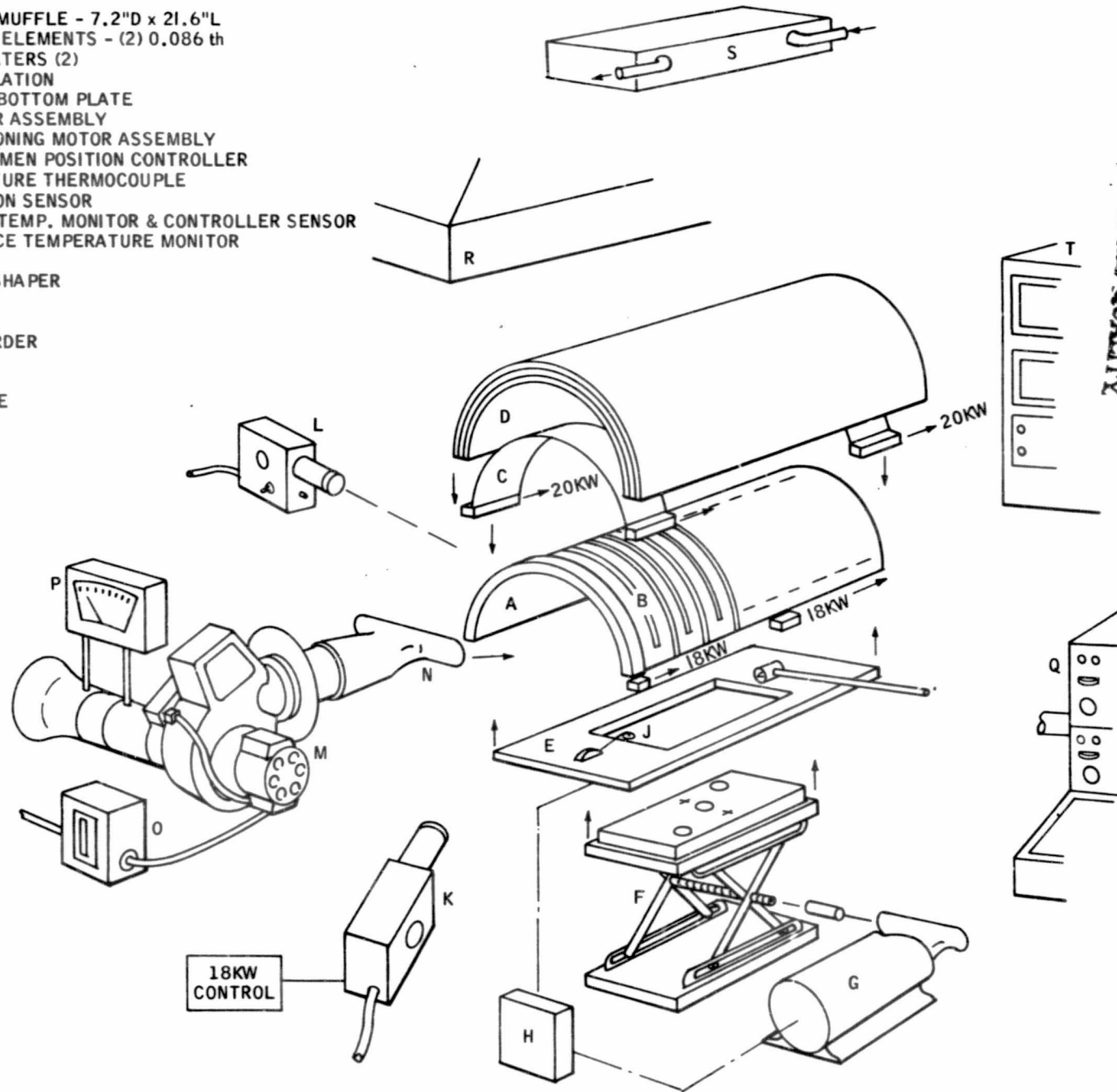

ORIGINAL PAGE IS
OF POOR QUALITY

EXPLODED VIEW OF THE MODEL 25 FIRE SIMULATION FACILITY

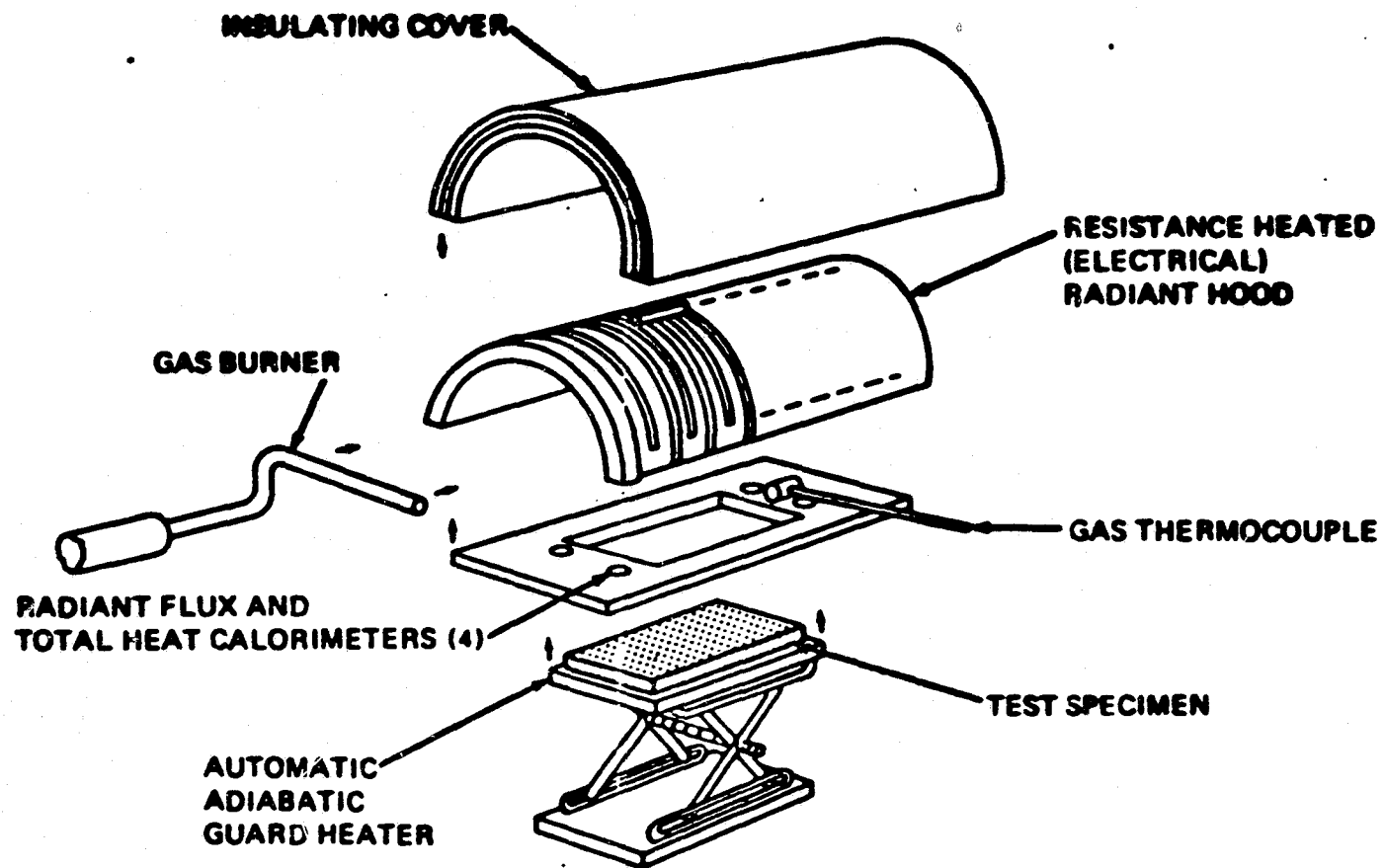
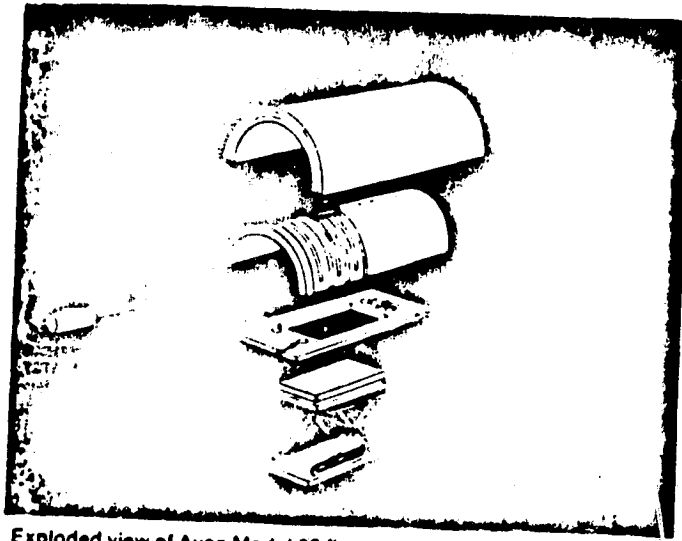

FIG. 3



Exploded view of Avco Model 25 fire simulation facility.

Fig 2.5-1

ORIGINAL PAGE IS
OF POOR QUALITY

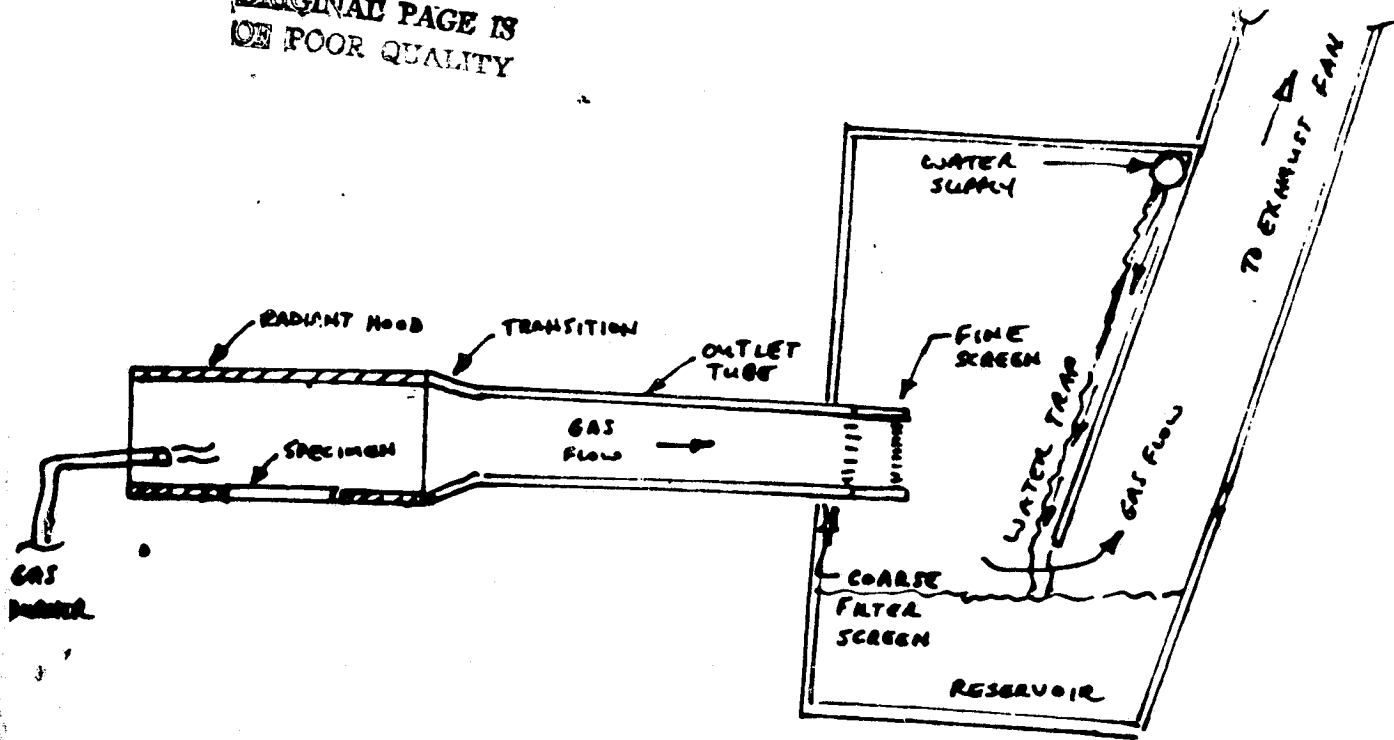

Figure 2.5-2

Model 25 Facility Modified for Fiber Containment

FIRE TEST RESULTS OF GRAPHITE-EPOXY COMPOSITES

IN AVCO'S MODEL 25 FIRE TEST FACILITY

<u>PARAMETER</u>	<u>SPECIMEN NUMBER</u>	
	<u>#153</u>	<u>#4</u>
<u>MATERIAL DESCRIPTION:</u>		
FIBER	T-300 GRAPHITE	T-300 GRAPHITE
RESIN	AS 3501-6 EPOXY	AS 3501-6 EPOXY
MANUFACTURER	HERCULES	HERCULES
LAMINATION	(+45,0,90,-45,0,90) X2	UNIDIRECTIONAL
SPECIMEN THICKNESS	~ 0.1 INCH	0.125 INCH
RESIN CONTENT	~ 30%	26%
<u>THERMAL ENVIRONMENT:</u>		
FIRE TEMP.	1850°F	1850°F
RADIATIVE HEAT FLUX ⁽¹⁾	9.5 BTU/FT ² SEC	9.5 BTU/FT ² SEC
CONVECTIVE HEAT FLUX ⁽¹⁾	1.5 BTU/FT ² SEC	1.5 BTU/FT ² SEC
REMARKS	CONVECTIVE HEAT FLUX OBTAINED FROM A FORCED AIR DRAFT--i.e., THERE WAS NO OIL OR GAS BURNER USED FOR THIS SET OF TESTS	
TEST TIME	10 MINUTES	10 MINUTES
<u>TEST DATA:</u>		
WEIGHT LOSS	63%	46%
MAXIMUM BACKFACE TEMP	~ 1650°F	1660°F

NOTES:

(1) AS MEASURED BY RADIOMETER AND CALORIMETER, RESPECTIVELY

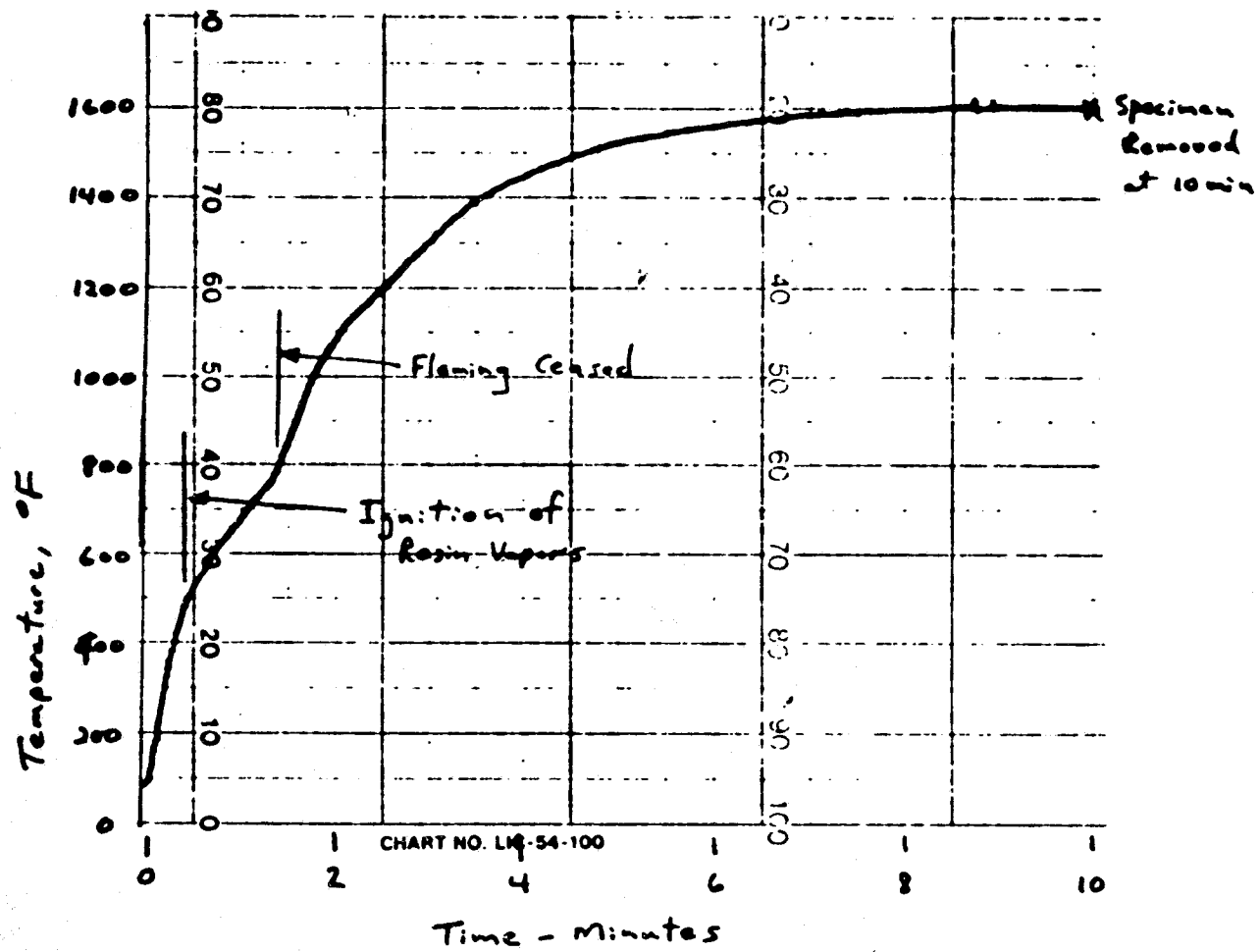

Figure 2.5-3 Backface Temperature Response, Specimen 187



#153 CROSS-PLY LAMINATE
RADIATIVE

ORIGINAL PAGE IS
OF POOR QUALITY

340

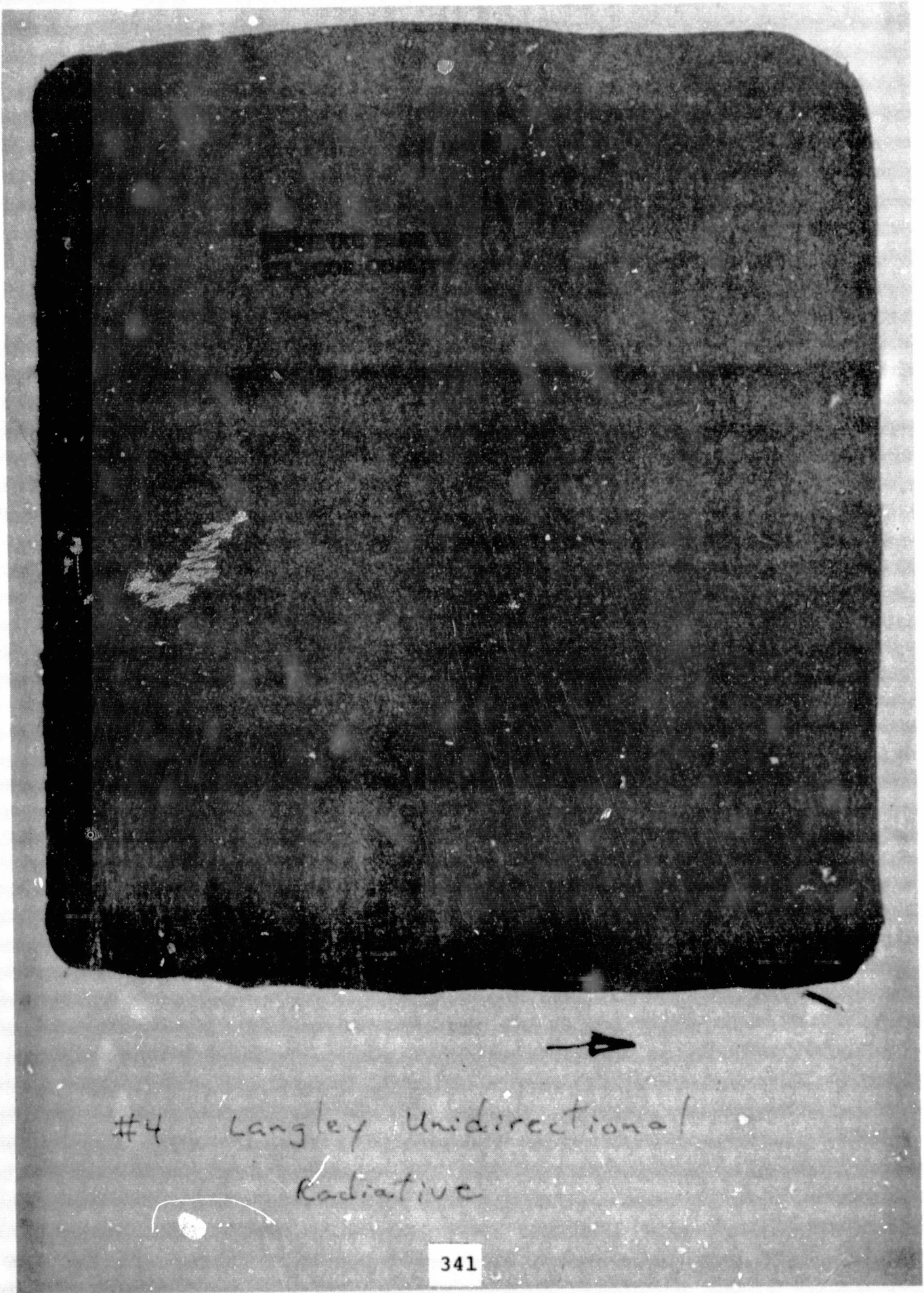

#4 Langley Unidirectional
Radiative

341

CONCLUSIONS FROM FIRE TEST EVALUATION OF
GRAPHITE EPOXY LAMINATES

- 1.) RESIN BURNED OFF IN LESS THAN 3 MINUTES.
- 2.) AFTER RESIN IS BURNED OFF, FIBERS ARE READILY REMOVED--
ESPECIALLY IF MECHANICAL PERTURBATION OCCURS.
- 3.) FIBER RELEASE MORE PRONOUNCED ON CROSS-PLY LAMMATES VS.
UNIDIRECTIONAL LAMINATES.
- 4.) UNIDIRECTIONAL LAMINATES WARPED DURING TEST
- 5.) ALL LIMINATES SWELLED TO AT LEAST 2X ORIGINAL THICKNESS
WITHIN THE FIRST 1-3 MINUTES OF FIRE EXPOSURE.

FIRE TEST FACILITY DEVELOPMENT

- 1.) IMPROVE FIBER COLLECTION TECHNIQUE AND/OR QUANTITATIVE
M'MENT OF FIBER RELEASE.
- 2.) ADD SELAS BURNER FOR HIGH \dot{q} c
- 3.) ADD MECHANICAL LOAD CAPABILITY
- 4.) SEAL AIR INGRESS LEAKS
- 5.) INCREASE SPECIMEN OR HOOD SIZE?
- 6.) CUT HOLD FOR BETTER MOVIE ACCESS? VIDEO TAPE?

APPENDIX A

CONVERSION OF MISCELLANEOUS UNITS TO
SI UNITS

The International System of Units (SI) was adopted by the Eleventh General Conference on Weights and Measures in Paris, October 1960^a. Factors for the conversion of the miscellaneous units used in this document to SI units are given in the following table:

Physical Quantity	Miscellaneous Unit	Conversion Factor (b)	SI Unit
Density	g/cc=g/cm ³	10 ³	kg/m ³
	g/ml	10 ³	kg/m ³
	lb/in ³	2.768x10 ⁴	kg/m ³
Energy	in-lb	0.113	J
Flow rate, volume	CFM=ft ³ /min	4.719x10 ⁻⁴	m ³ /s
Heat flux	Btu/ft ² s	1.135x10 ⁴	W/m ²
Length	A	10 ⁻¹⁰	m
	ft	0.3048	m
	" = in.	0.0254	m
	μ = micron	10 ⁻⁶	m
	mil=10 ⁻³ in.	2.54x10 ⁻⁵	m
Mass	lb	0.4536	kg
Pressure	mm Hg	133.3	Pa
Stress	psi=lb/in ²	6895	Pa
	kpsi=ksi=10 ³ lb/in ²	6.895x10 ⁶	Pa
	Mpsi=Msi=10 ⁶ lb/in ²	6.895x10 ⁹	Pa
Stress intensity	ksi-in ^{1/2}	1.099x10 ⁶	N/m ^{3/2}
Temperature	°C	°C+273.15	K
	°F	(°F+459.67)/1.8	K
Thermal efficiency	Btu/lb	2324	J/kg
Velocity	ft/s	0.3048	m/s
	knot	0.5144	m/s

a Anon.: Standard for Metric Practice. ASTM Designation: E 380-76. Amer. Soc. Testing Mater., c. 1977.

b Multiply value given in miscellaneous unit by conversion factor to obtain equivalent value in SI unit (with the exception of temperature).