

THE TECHNOLOGY ASSESSMENT OF LTA AIRCRAFT SYSTEMS

Japan Industrial Technology Association

(NASA TM-75535) THE TECHNOLOGY ASSESSMENT
OF LTA AIRCRAFT SYSTEMS (National
Aeronautics and Space Administration) 362 p
HC A16/MF A01 CSCI 01A

N78-32043

Unclas
63/02 30325

Translation of "LTA Kōkūki System on Technology Assessment," Report on Research Commissioned in 1977 by the Technology Evaluation Committee, Agency of Industrial Science and Technology, Japan Industrial Technology Association, March 1978, pp. 1 - 269 (Chapters I-VI).

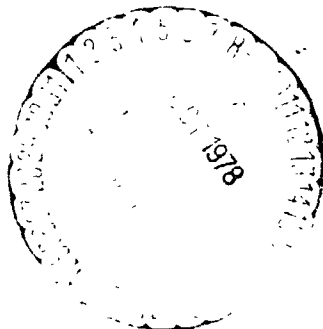

NATIONAL AERONAUTICS AND SPACE ADMINISTRATION
WASHINGTON, D.C. 20546 SEPTEMBER 1978

Introduction

/1

A survey study has already been under way in our country for the past two years concerning the questions: what are LTA craft and of what use are they? The survey has been sponsored by the Japan Society for the Promotion of Machine Industry. In this survey, a general study has been made of the conventional types of small and large-size airships and of the possibilities of balloon systems in new applications.

During the course of these studies it was felt that, if the conventional types of airships were to be used without any further modifications, their applications would be limited to uses such as air patrolling in view of their extremely slow cruising speed in comparison with the HTA aircraft of today and their highly inferior maneuvering properties.

Nevertheless, LTA craft also have a number of advantages. Thus, if hybrid LTA aircraft were to be combined with HTA aircraft in various ways, it might be possible to perfect new types of aircraft in which the drawbacks of both would be eliminated and the advantages of both would be displayed to the full. Attention has been paid to this point in various countries of the world, and numerous plans for different combinations have already been made public thus far. Naturally, the drawbacks of the LTA will still remain. That is, since the buoyant gas has little static buoyancy, the size of the vehicle as a whole will be quite large in comparison to its total weight, and there will be many problems in handling them on the ground. In addition, the price of a hybrid LTA will naturally be more expensive than that of a pure LTA. Even at that, is there not a demand somewhere for one type of hybrid LTA or another? As social conditions have been changing, the demands on aircraft have become more and more multi-faceted. Are there not some markets somewhere which some sort of hybrid LTA could

satisfy under more advantageous conditions in a field where the requirements cannot be fully met by conventional HTA or means of land transport?

Quite recently, the existence of such markets has become apparent to us with considerable clarity. The chief purpose of this survey was to sketch out, as vividly as was possible, the outlines of these markets and to elucidate the possible technologies which might be able to meet their requirements.

The results of the survey showed that there are markets where there is a greater possibility of realization than we had formerly supposed, and that there are social requirements more urgent than we had imagined. One possible area is that of short-distance transport of heavy cargoes by hybrid LTA consisting of a combination of helicopter rotors and LTA. This area has attracted the attention of specialists in America and France, where research is already under way. Furthermore, it was suggested in our survey that, under certain conditions, hybrid LTA aircraft might be able to operate to better advantage than HTA STOL cargo planes in the field of short-distance mass passenger transportation within Japan.

Of course, we have only reached the end of our first stage of approach to technological studies concerning hybrid LTA. Nevertheless, as far as we can tell from the results of this survey study, it will definitely be worth our while to move ahead to the next stage. In the next stage, our study will not be limited to merely theoretical surveys; in parallel with these, we ought also to move one step forward in the direction of actually building something.

Since LTA craft have vanished from the aeronautics world for a long time, they are quite unfamiliar in general to specialists, and there are probably many who, on the basis of their impressions

of the old airships of many years ago, have a negative opinion of them and think that they do not meet the requirements of contemporary society. However, we hope that everyone in the various fields of aeronautics will understand thoroughly that the introduction of the new concept of the hybrid has opened up possibilities for the development of a means of transportation which technically cannot be ignored.

Preliminary Chapter

/11

1. Purposes

In recent years there have been more and more exacting demands for transportation systems to attain higher efficiencies, to conserve energy, and to protect the environment. Nevertheless, it has become difficult to meet these requirements adequately on the basis of the existing transportation systems alone. What means of transport (tools) ought to be used to cope with these requirements of society and of manufacturing which cannot be satisfied by automobiles, railroads, seagoing vessels, and HTA (heavier-than-air) aircraft alone?

LTA (lighter-than-air) aircraft have been attracting attention as one of the means of transportation for coping with the new requirements of society. That is, they have good VTOL performance, large transport capacities, and low noise. They consume little fuel. Furthermore, the land they require for their bases on land is far less than the lots required for HTA airports. These characteristic features of LTA aircraft appear to afford us a bright ray of hope about fulfilling the social requirements (needs) which are currently being formulated. These social requirements include also such items as the airlifting of civil engineering machinery for the construction of hydroelectric power stations to be build far inland, the airlifting of heavy cargoes such as

power station machinery, the airlifting of materials for the construction of power transmission lines, or even passenger planes for mass transportation of short-distance interurban commuters. The craft could also be used for transportation to isolated islands.

In this survey study, we first made a search for the market conditions in order to find out the scale and contents of the above-mentioned social-requirements in each field. We next made a study of the technological possibilities of the so-called hybrid LTA, among the various types of LTA aircraft, as a technological means which might be able to solve these requirements. Our purpose in this was to match the "needs" and the "seeds."¹

On the basis of these results, we next collected materials for making an overall decision about the following questions. That is, what type of a contribution could LTA aircraft make throughout the entire field, and to which social fields could it make a contribution? If LTA aircraft are to be developed in the future, what type of LTA aircraft ought to be given first priority?

2. Topic Studied

Survey studies have previously been made of some types of aircraft belonging to the LTA aircraft field, such as conventional types of small and large-size airships and balloons. Consequently, the materials concerning the above-mentioned types of LTA have already been published, and we have used the results of these survey studies.

Therefore, in this survey study we limited our technological study to a single topic: the hybrid type LTA.

1) These words are in English in the original. - Tr.

3. Organization of the Survey Study

An "LTA Aircraft Systems Committee" consisting of the following men of experience and learning was set up in the Japan Industrial Technology Association. We also set up a Working Group composed /iii of specialists from various fields and a coordinator. The basic guidelines of the survey study were determined in the Committee, which made the final evaluation of the results of the survey conducted by the Working Group.

Committee Members

[Members] (Not listed in order of importance)

- * Hidemasa Kimura, Professor Emeritus, Nihon University
- Akira Azuma, Professor, University of Tokyo (Institute of Space and Aeronautical Science)
- Ryohei Tsunomoto, transportation critic (Transportation Economics Research Center)
- Makoto Hashizume, chief official, Aircraft Division, Aircraft Business Department, Mitsubishi Heavy Industries, Ltd.
- Tadao Takahashi, director, Planning Department, Aircraft Business Headquarters, Kawasaki Heavy Industries, Ltd.
- Susumu Kuwahara, director, EPDC International
- Shinzo Tanaka, president, Airship Development Organization, Ltd.

[Observers]

- Hiroshi Shima, director, Technology Research Division, General Coordination Department, Agency of Industrial Science and Technology
- Hisakatsu Yamada, director, Aircraft and Ordnance Division, Machinery and Information Industries Bureau, Ministry of International Trade and Industry

* Committee chairman

Takayuki Hirano, director, General Coordination Section,
Technology Research and Information Division, General
Coordination Department, Agency of Industrial Science
and Technology

Hidefusa Miyama, director, Aircraft and Ordinance Section,
Aircraft and Ordinance Division, Machinery and Information
Industries Bureau, Ministry of International Trade and
Industry

Ikuo Toyama, staff specialist for technology research,
Technology Research and Information Division, General
Coordination Department, Agency of Industrial Science
and Technology

Mitsuaki Takeda, staff specialist for technology research,
Technology Research and Information Division, General
Coordination Department, Agency of Industrial Science
and Technology

Soichi Nagamatsu, assistant section chief, Aircraft Technology
Unit, Aircraft and Ordinance Division, Machinery and
Information Industries Bureau, Ministry of International
Trade and Industry

[Working Group]

Akira Azuma, professor, University of Tokyo

Korin Oka, chief officer, Aircraft Basic Design Division,
Second Technology Department, Nagoya Aircraft Works,
Mitsubishi Heavy Industries, Ltd.

Akihiko Onden, Office of Senior Officer for Development
Programs, General Coordination Department, Agency of
Industrial Science and Technology

Motohisa Komatsu, director, Heavy Cargo Transport Department,
Tokyo Shibaura Electric Co., Ltd.

Yoshinori Sakai, assistant section chief, Basic Planning
Division, Technology Department, Aircraft Business
Headquarters, Kawasaki Heavy Industries, Ltd.

Norio Yamanouchi, chief official, Market Survey Section,
Planning Office, Private Cargo Plane Development
Association, Inc.

Kazumasa Iinuma, researcher assigned by Japan Industrial
Technology Association to post of secretary-general,
Bouillant Aviation Conference Secretariat

[Secretariat]

Tsuneo Momoda, director, Japan Industrial Technology
Association

Kazumasa Iinuma, researcher, Japan Industrial Technology
Association

Isshi Watanabe, director-general, TA Department, Japan
Industrial Technology Association

GENERAL CONTENTS

Chapter I. Outline of Various LTA Aircraft Systems

I-1. Definition and Classification of LTA Aircraft.....1
I-1-1. Balloons.....1
I-1-2. Airships.....2
I-2. Positions of Various Types of Aircraft in the Overall
System of Aeronautic Technology.....4
I-2-1. Basic Functions of Aircraft.....4
I-2-2. Comparison of Basic Functions of Various Aircraft.....7
I-3. Past Achievements in LTA Aircraft Research in Our
Country.....9
I-3-1. Outline.....9
I-3-2. First Survey Study..... 13
I-3-3. Second Survey Study..... 19

Chapter II. Study of Hybrid LTA (Part 1) - General Study - ... 25

II-1. Definition and General Information about Hybrid LTA..... 25
II-2. Reasons why Hybrid LTA Are Targets for Development..... 30
II-3. Matching of Needs and Seeds..... 31
II-4. Selection of Specific Aircraft Models..... 32

Chapter III. Study of Hybrid LTA (Part 2) - Social Requirements
(Needs) in Our Country. -

III-1. Current State of Heavy Cargo Transport and Problems
at Issue..... 35
III-1-1. Transport of Power Generating Equipment for Pumped-
Storage Power Stations and Station Construction..... 36
III-1-2. Transport of Power Generating Equipment for Hydro-
electric Power Stations and Station Construction..... 46
III-1-3. Transport of Power Generating Equipment for Geother-
mal Power Stations..... 53
III-1-4. Transport Problems in Construction of Power Trans-
mission Lines..... 60

III-1-5.	Transport for Construction of Power Substations.....	67
III-1-6.	Problems of Heavy Cargo Transport in Connection with Rationalization of the Japanese National Railways.....	86
III-1-7.	Bridge Building, Penstocks, and LTA.....	87
III-1-8.	Heavy Cargo Transport in Dam Construction and LTA....	89
III-1-9.	Transport Data for Reference in Connection with LTA Use.....	94
III-1-10.	Anticipated Annual Demand for LTA.....	95
III-2.	Current State of Large-Size Helicopters and Problems at Issue.....	97
III-3.	Current State of Short-Distance Aviation and Passenger Transportation and Problems at Issue.....	105
III-3-1.	Problems at Issue in Short-Distance Air Transporta- tion and the Materials which Are Being Sought.....	105
III-3-2.	Short-Distance Air Transportation in the Environs of Large Cities.....	114
III-3-3.	Current State of Transport to Isolated Islands and Problems at Issue.....	117
III-3-4.	STOL Aircraft Development in Our Country.....	141
III-4.	Social Requirements for Means of Airborne Assistance in the Event of Emergencies.....	150
 Chapter IV. Technological Studies Concerning Specific Selected Hybrid LTA.....		
IV-1.	Outline.....	163
IV-2.	Determining the Required Performance Properties.....	164
IV-2-1.	For Heavy Cargo Transport.....	169
IV-2-2.	For Passenger Transportation.....	170
IV-3.	Study of Rota-Ship Hybrid Airship.....	174
IV-3-1.	Study of Rota-Ship for Passenger Transportation.....	174
IV-3-2.	Study of Rota-Ship for Heavy Cargo Transport.....	175
IV-3-3.	Problems of Mooring Sites, Sites for Landing and Take-off, Etc.....	195

/v

IV-3-4.	Development Plans and Development Expenses.....	217
IV-3-5.	Estimates of Operating Costs of Rota-Ships for Passenger Use.....	219
IV-3-6.	Estimates of Operating Costs of Rota-Ships for Heavy Cargo Transport.....	224
IV-4.	Study of Skycrane Hybrid Airship.....	226
IV-4-1.	Outline.....	226
IV-4-2.	Determining Skycrane Specifications.....	232
IV-4-3.	Performance Properties.....	246
IV-4-4.	Stability.....	248
IV-4-5.	Reference Materials.....	263
IV-4-6.	Methods of Operation.....	264
IV-4-7.	Development Plans.....	269
IV-4-8.	Estimates of Operating Costs of Skycranes.....	270
IV-5.	Estimates of Operating Properties of Megalifter Type Aircraft.....	277
IV-5-1.	Resistance.....	277
IV-5-2.	Lift Resistance Characteristics.....	282
IV-5-3.	Performance Properties.....	283
IV-6.	Technological Studies of Automatic Operating Devices of Suspended Gondolas.....	287
IV-6-1.	Suspended Maneuvering Module (SMM).....	287
IV-6-2.	Study of Concept of Suspended Maneuvering System with SMM Suspended on LTA.....	291
Chapter V.	Studies of Two Anticipated Problems.....	293
V-1.	The Problem of Supply and Demand for Helium.....	
	Introduction.....	293
V-1-1.	Historical Background of Helium.....	295
V-1-2.	Uses of Helium.....	298
V-1-3.	Helium Resources.....	299
V-1-4.	United States' Plan for Preservation.....	301
V-1-5.	Prospects for Future Supply and Demand for Helium.....	302
V-2.	Study of Laws Concerning Suspended Transport.....	303

Chapter VI. Comprehensive Evaluation.....	315
VI-1. Evaluation of the Hybrid LTA Chosen as Targets for this Survey.....	315
VI-1-1. Outline.....	315
VI-1-2. Hybrid Airships for Regular Passenger Transportation.	317
VI-1-3. Hybrid Airships for Heavy Cargo Transport.....	336
VI-2. Comprehensive Evaluation of LTA Aircraft as a Whole....	346
Main Overseas References.....	
I. Current State of LTA Aircraft Development in the U.S.A.....	*
II. NASA's Second Report on Feasibility of Modern Airships (Outline).....	*

*Not translated. Original in English,

Chapter I. OUTLINE OF VARIOUS LTA AIRCRAFT SYSTEMS

CONTENTS

I-1. Definition and Classification of LTA Aircraft.....	1*
I-1-1. Balloons.....	1
I-1-2. Airships.....	2
I-2. Positions of Various Types of Aircraft in the Overall System of Aeronautic Technology.....	4
I-2-1. Basic Functions of Aircraft.....	4
I-2-2. Comparison of Basic Functions of Various Aircraft....	7
I-3. Past Achievements in LTA Aircraft Research in Our Country.....	9
I-3-1. Outline.....	9
I-3-2. First Survey Study.....	13
(a) Small-Size LTA's.....	13
(b) Large-Size LTA's.....	17
I-3-3. Second Survey Study.....	19
(a) LTA's for Cargo-Handling.....	21
(b) Domestic Production of Small-Size LTA's for Use in Urban Areas.....	22
(c) Survey on Ground Facilities.....	24
(d) Laws Concerning Operating Organization.....	24

I-1. Definition and Classification of LTA Aircraft.

/1**

Aircraft are classified according to whether they are heavier or lighter than air: HTA (heavier-than-air) aircraft or LTA (lighter-than-air) aircraft.

The fixed- and rotary-wing aircraft which are mainly used at present are classified as HTA aircraft, while balloons and airships are called LTA aircraft. LTA aircraft are equipped with air tanks filled with gas which is lighter than air and which renders buoyancy to the aircraft so that it can stay in the air.

LTA aircraft are classified into two broad categories, 1) balloons and 2) airships. This classification is based upon the existence or the lack of horizontal self-navigation ability. Needless to say, the LTA aircraft which have horizontal self-navigation ability are airships and those without it are balloons. (See Fig. I-1.)

I-1-1. Balloons.

Usually, balloons are categorized into captive balloons (balloons moored to mooring ropes) and free balloons (balloons not moored). Clas-

* Page Number in Translated Text.

** Numbers in the margin indicate pagination in the foreign text.

sification of balloons according to their structure, such as rigid and non-rigid balloons, did not exist in the past. All the balloons built in the past had a non-rigid structure, like toy balloons. Why rigid balloons have never appeared in history may be explained by the lack of demand for balloons so huge that their structure must be rigid.

Among the well-known free balloons are those used for meteorological observation in the upper layer of the earth's atmosphere, or those used for cosmic ray observation in its uppermost layer. These balloons are not manned. Up until the 1930's, however, manned balloons had been used for observation purposes. The most outstanding achievement in this area was that of A. Piccard and Kipfer who reached the stratosphere (15,500 m), in a balloon which had an air-tight chamber under it.

Recently, manned balloons have gained popularity and riding balloons has become a new sport. The movement of such balloons may be controlled only in the vertical direction (altitude), by means of mechanisms which control the buoyancy of the buoyant gas of the balloons. Many of these recreational balloons use hot air as buoyant gas. The buoyancy is controlled by gas burners which regulate the amount of the hot air.

Captive balloons were used in Japan for air defense purposes until World War II. Balloons used for advertisement are the most familiar captive balloons nowadays. Interest has also been stimulated in the various applications of captive balloons to many fields - those fields in which balloons were used frequently even before World War II, i.e., meteorological observation, emergency warning, communication, command relay, etc., as well as new fields in which the use of balloons was not considered before World War II, i.e., transportation of construction materials or heavy cargoes, etc. It was immediately after World War II that balloons began to be used for airlifting lumber from forests. These balloons have been continually developed and are now under consideration for use in cargo handling at harbors. /2

I-1-2. Airships.

Airships are usually divided into three categories; rigid, semi-rigid and non-rigid airships. The rigid airships have a structure in which a hull with framework is covered by outer coverings. The hull includes one or more air tank(s) containing buoyant gas. A rigid structure consists of two portions, one which renders durability to the hull and one which creates the buoyancy of the ship. As the size of an airship increases beyond a certain limit, it becomes preferable to have two separate structures, each of which fulfills one of the above two functions. The giant airships which have been built since the Zeppelin airships are all of the rigid type.

Non-rigid airships are, so-to-speak, balloons with horizontal propelling mechanisms. They do not have any framework or rigid structure. These non-rigid airships have air tanks which contain buoyant gas and, at the same time, render durability to the ships.

Since the early 1930's when the zeppelin airships made their debut

until the explosion accident of the Hindenburg in 1937, most giant airships had been of the rigid type. However, since those airships disappeared, only non-rigid ones have been built, partially due to the abandonment of the attempt to scale up the ship size. Nevertheless, recent development, mostly in the U.S.A., is in such a stage that airships with non-rigid structure can be built to a size of 150 to 160 thousand m³.

A semi-rigid type airship, that is, an airship with a hull structure a part of which is of rigid type, or a non-rigid airship, the lower part of which is reinforced by keels and beams, has been built in the past.

The types of airships which are in use or under consideration at present in various countries of the world are summarized in Fig. I-2. This list was compiled by Bruno A. Jener and John J. Schneider (Boeing Vertol Co., U.S.A., 1975).

Cf. "Evaluation of Advanced Airship Concepts," AIAA Paper, No. 75-930.

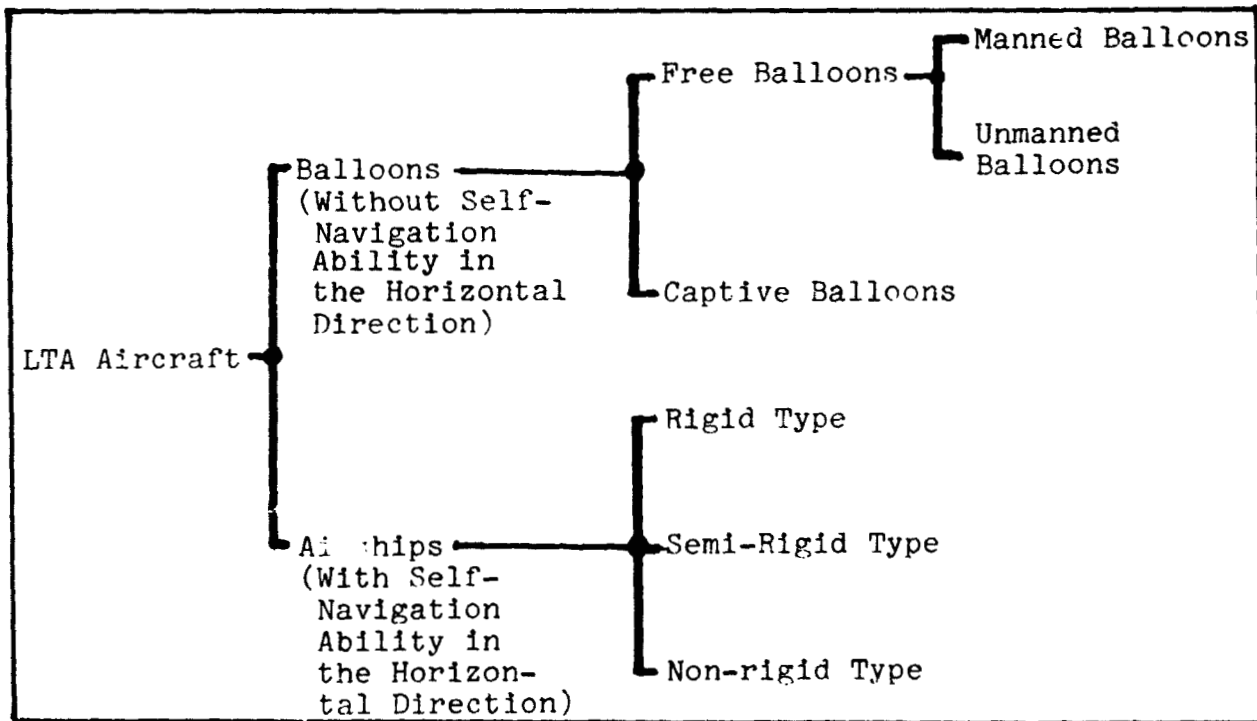

Fig. I-1. Classification of LTA Aircraft.

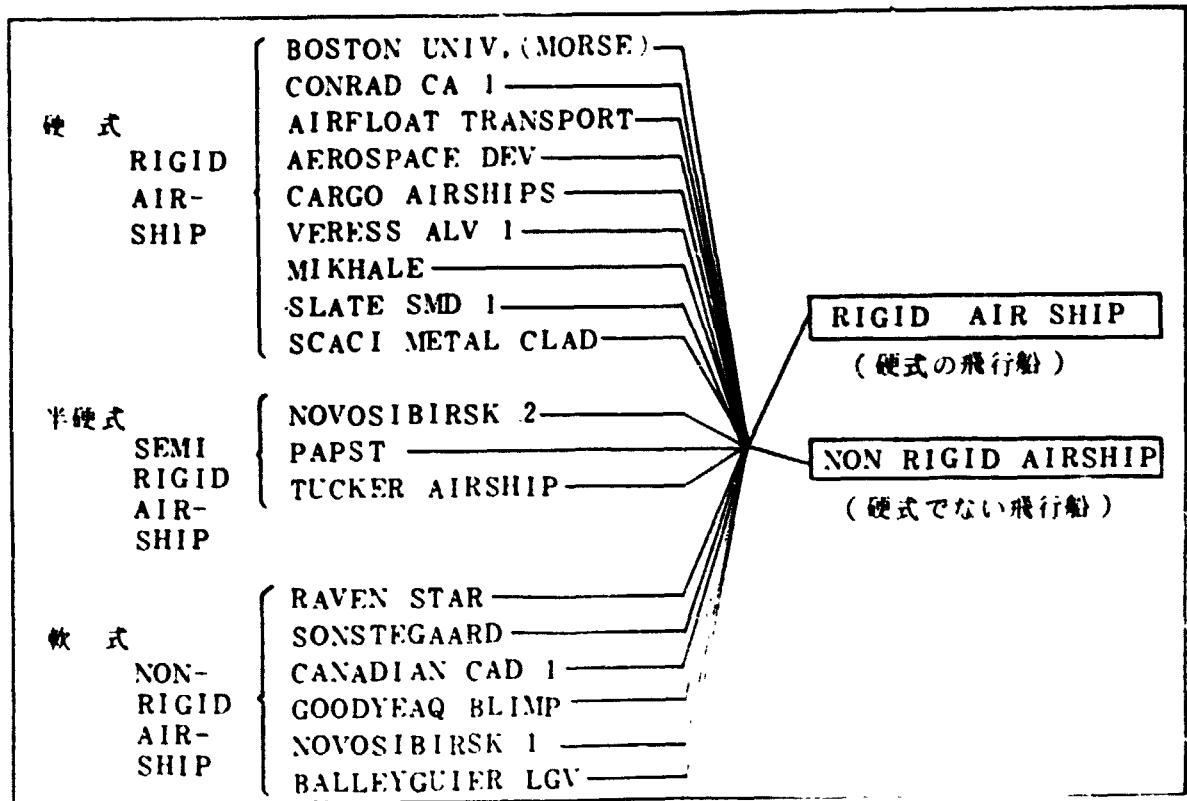

Fig. I-2. Classification of Airships.

I-2. Positions of Various Types of Aircraft in the Overall System of Aeronautic Technology.

There exist, more or less, some fields in which demands cannot be met by the functions of the presently used HTA aircraft. In order to identify those fields, the basic functions of both HTA and LTA aircraft as means of aeronautic transportation are summarized in this section.

This summary is rather conceptual, and hence, very qualitative. Some quantitative characterizations are also made, but they are not rigorous.

I-2-1. Basic Functions of Aircraft.

Basic functions of various types of aircraft, as tools of air transportation, are categorized as follows: (See Fig. I-3.)

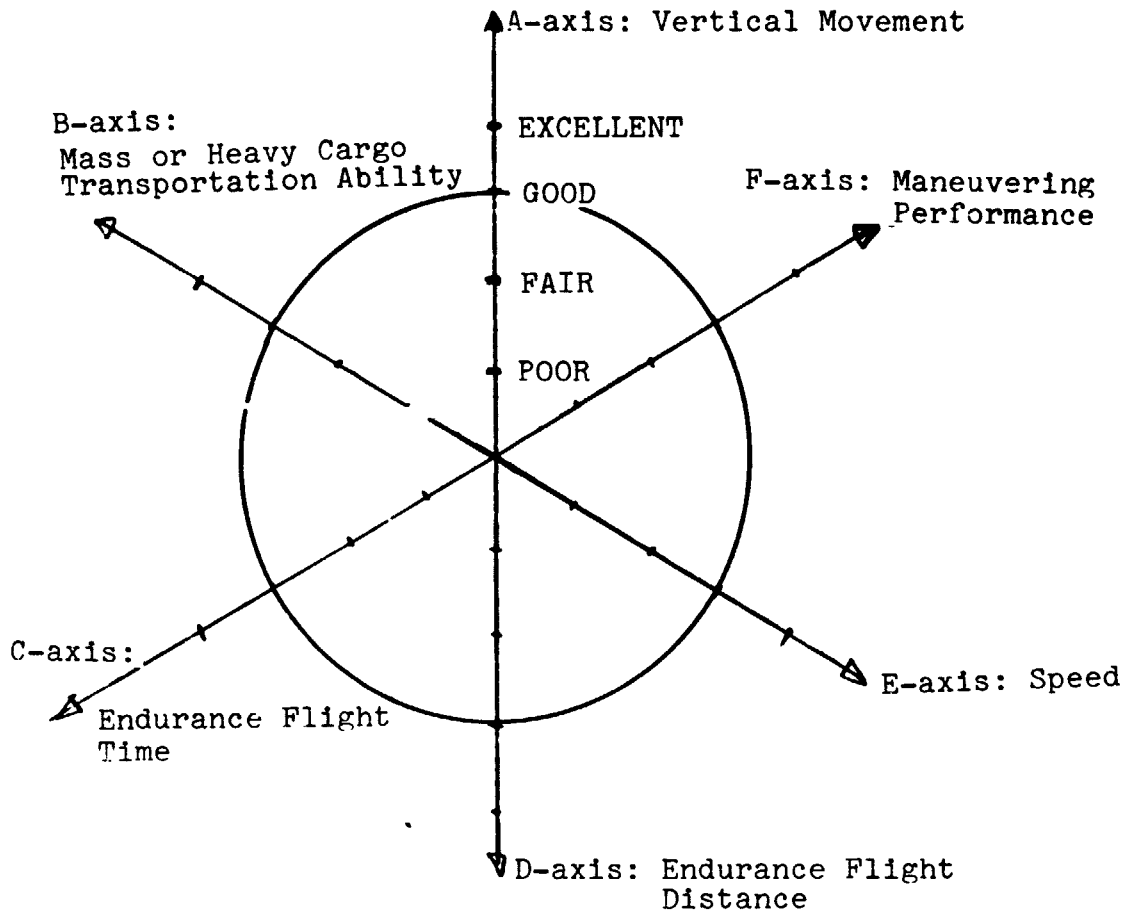

Fig. I-3. Aircraft Evaluated by their Basic Functions.

(1) Vertical Movement.....A-axis.

The ability of vertical take-off and landing, the ability to stay in the air, and the ability of vertical displacement.

(2) Mass or Heavy Cargo Transportation Ability.....B-axis.

How large a quantity or how heavy a mass the aircraft can carry.

(3) Endurance Flight Time.....C-axis.

How long the aircraft can fly in one flight.

(4) Endurance Flight Distance.....D-axis.

How far the aircraft can fly in one flight.

/5

(5) Speed.....E-axis.

How fast the aircraft can fly.

(6) Maneuvering Performance.....F-axis.

How freely or how easily the aircraft can be maneuvered, can take-off and land at the airport, or can load and unload cargoes.

The basic functions classified into the above categories are graphically shown on the six axes in the six different directions (See Fig. I-3.). Every axis is scaled by the following four evaluation grades: "poor," "fair," "good" and "excellent." Each grade in each category has the following meaning:

A-axis: Vertical Movement.

poor: STOL is possible with certain difficulties.
fair: STOL is possible, but neither VTOL nor hovering is possible.
good: VTOL as well as STOL is possible, but not hovering.
excellent: Hovering is possible as well as VTOL and STOL.

B-axis: Mass or Heavy Cargo Transportation Ability.

poor: Can carry several tons.
fair: Can carry several tens of tons.
good: Can carry around a hundred tons.
excellent: Can carry hundreds of tons.

C-axis: Endurance Flight Time.

poor: Can fly for only two to four hours.
fair: Can cruise for four to ten hours.
good: Can cruise for ten to twenty hours.
excellent: Can cruise for one day or more.

D-axis: Endurance Flight Distance.

poor: Less than 300 km.
fair: 300 to 1,000 km (within Japan).
good: 1,000 to 10,000 km (approximately from Tokyo to Hawaii or Tokyo to Los Angeles).
excellent: More than 10,000 km (e.g. Tokyo - New York).

E-axis: Speed.

poor: 50 to 100 km/hour.
fair: 100 to 300 km/hour.
good: 300 to 700 km/hour.
excellent: higher than 700 km/hour.

F-axis: Maneuvering Performance.

- poor: Cannot approach airports without aid.
- fair: Has maneuvering performance comparable to CTOL aircraft. (Cf. CTOL = Conventional Take-Off and Landing)
- good: Hovering is possible but only with aid of wind.
- excellent: Hovering is possible even in windless weather.

I-2-2. Comparison of Basic Functions of Various Aircraft.

Based upon the above-mentioned grading system,

- (1) fixed-wing aircraft (HTA),
- (2) rotary-wing aircraft (HTA),
- (3) airships (LTA), and
- (4) captive balloons (LTA),

/6

are evaluated as follows:

Fixed-Wing Aircraft.

(Fig. I-4)

A-axis: Can only manage to perform STOL, and hence, have a poor vertical movement performance.

B-axis: Have difficulties in carrying hundreds of tons at a time, but may carry as much as 100 or 200 tons.

C-axis: Can fly for many hours, as many as 10 to 20, but cannot endure a flight longer than a day.

D-axis: Have excellent ability to cruise long distances.

E-axis: Have excellent speed: Can possibly fly at sonic speed.

F-axis: Have sufficient maneuvering performance, but are rather poorly maneuvered at a low speed.

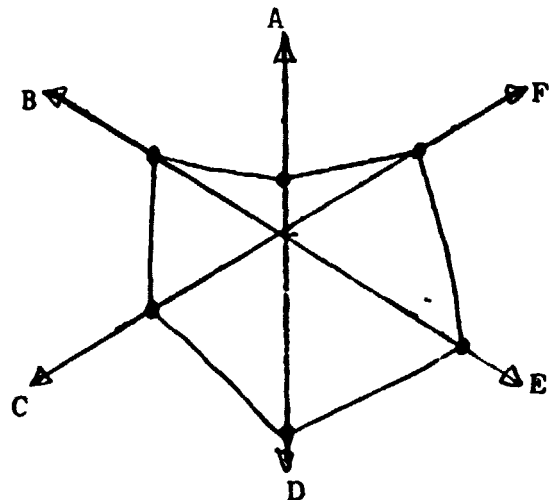

Fig. I-4. Fixed-Wing Aircraft.

Rotary-Wing Aircraft.

(Fig. I-5)

A-axis: Exact VTOL or hovering is possible.

B-axis: A commercial one can carry at most 10 tons, while none, even of the military type, can carry more than 50 tons at present.

C-axis: None has more than a 10 hour endurance flight record. Normally, 2 to 3 hours.

D-axis: Around 300 km/hour.

E-axis: Have excellent maneuvering performance, and can load and unload cargoes while hovering.

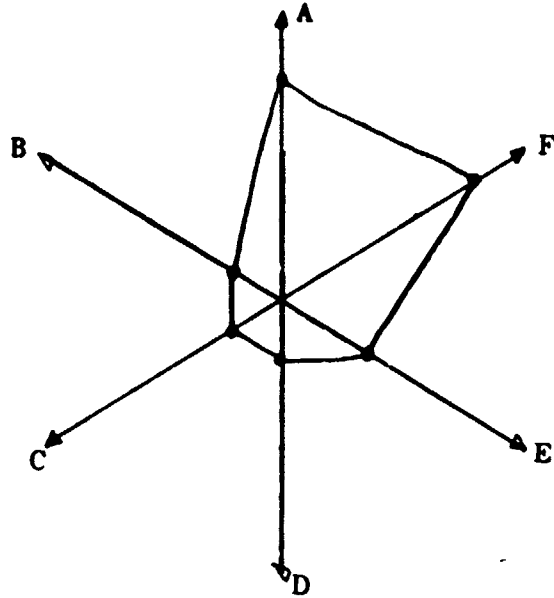

Fig. I-5. Rotary-Wing Aircraft.

Airships. (Fig. I-6)

/7

A-axis: VTOL is possible. Hovering is also possible to some extent. However, the hovering ability is considerably poorer than rotary-wing aircraft.

B-axis: Can carry around 100 tons at a time without difficulties and will manifest no significant technical disadvantage even if scaling-up is attempted up to carriers of hundreds of tons to thousands of tons.

C-axis: The endurance flight record may possibly exceed that of the ordinary fixed-wing aircraft.

D-axis: Since the speed is low, the cruising distance is short even with long endurance flight time.

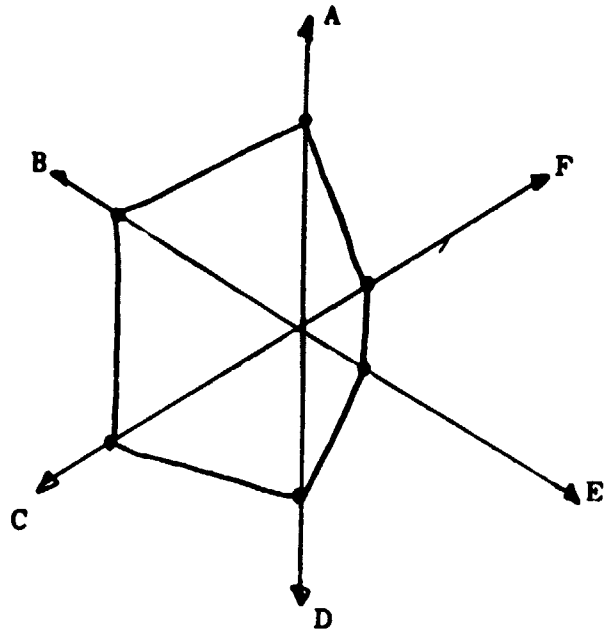

Fig. I-6. Airships.

E-axis: The speed is lower than rotary-wing aircraft and almost the same as railroad trains.

F-axis: Have considerably poor maneuvering performance, as poor as railroad systems.

Captive Balloons. (Fig. I-7)

A-axis: VTOL is possible, while hovering is also possible to some extent (by three-rope mooring).

B-axis: At present, can carry at most, tens of tons. The carrying capacity has not developed well, partially due to the lack of social requirement.

C-axis: Are the most excellent in this respect. Some can float even for several months as captive floating objects.

D-axis: Can hardly move.

E-axis: Can move horizontally by means of mooring ropes controlled on the ground, but the speed will be at most several tens km per hour.

F-axis: Very poor. Cannot be maneuvered.

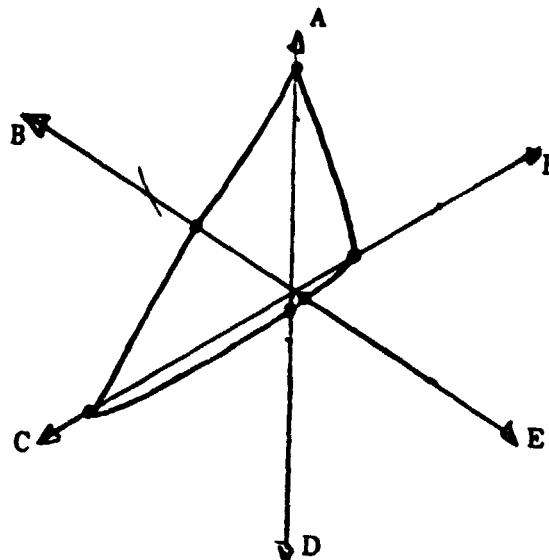

Fig. I-7. Captive Balloons.

The four types of aircraft (tools in the air - aeronautic transportation means) have been evaluated herein. None of these aircraft can achieve a sufficient grade in every function at the same time. Thus, it is necessary to compose or hybridize these aircraft in response to the new needs of industrial societies. /8

It is for this reason that hybrid LTA have become a major object of study in various countries of the world. Generally, by hybrid LTA, is denoted hybrid aircraft composed of LTA and HTA aircraft. These hybrid aircraft are designed to obtain dynamic lift as well as buoyancy.

I-3. Past Achievement in LTA Aircraft Research in Our Country.

I-3-1. Outline.

Since World War II, it was after 1968 that LTA aircraft began to once again be recognized in our country. At first, a non-rigid-type of

airship with about 4,000-m³ gas capacity was imported from West Germany in 1968. This importation was advocated by Mr. Shinzo Tanaka (presently representative of the Organization for the Development of Airships). This airship was used for advertisement for about seven months. However, it was heavily damaged during captivity at Tokushima, Shikoku, due to strong winds. Mr. Tanaka introduced another airship from West Germany, in 1973. This airship was of the non-rigid type and had about 6,000-m³ gas capacity. This ship was likewise operated for advertisement purposes for about one year. Unfortunately, this second ship was also destroyed during captivity at Okegawa, Saitama Prefecture, due to strong winds.

There are no examples of practical operation of LTA airships in Japan except for these two. Hence, despite the two consecutive accidents, the data and the experience obtained during the operation of these airships are valuable and indispensable.

Based on the advocacy of the late Mr. Sekizo Kondo and others, Buoyant Aviation Conference (headed by Mr. Hidemasa Kimura, president) was founded, mainly by non-governmental personnel. By this Conference, studies have been continued regarding the possibility of manufacturing LTA aircraft in Japan and of their utilization in industries.

The Japan Association for the Promotion of Machine Industry undertook a survey study on the possibilities of LTA aircraft, based on the historical background. This study was approached from both technical and social aspects and lasted two years (fiscal years, 1975 and 1976). In the course of this survey study, the LTA aircraft were classified into the following three divisions:

- (1) small-size LTA (airships with 1 to 10-ton payload),
- (2) large-size LTA (airships with 10 to 500-ton payload), and
- (3) LTA for cargo handling (balloons with more than 1-ton payload).

The first survey in fiscal year 1975 included: estimation of manufacturing costs of small-size rigid and non-rigid LTA's, conceptual sketch designs of these LTA's, estimation of the manufacturing costs of large-size rigid LTA's, estimation of the operating costs when these LTA's are used in Pacific liners, and overview of maneuvering performances of both small- and large-size LTA's. In addition, this survey included studies on social demands in Japan for small- and large-size LTA's. /9

The second survey in fiscal year 1976 summarized: technical studies on captive balloons, unmanned airships for meteorological observation, small-size manned airships and others, investigations of the necessary scale of ground facilities for small- or large-size LTA's, and in addition, conceptual sketch designs for harbor cargo handling systems using captive balloons.

The "Table of Contents" of the report of each survey study is cited later.

SURVEY STUDY ON LTA AIRCRAFT SYSTEMS - FIRST SURVEY STUDY

TABLE OF CONTENTS

Chapter I. Technical Possibilities Concerning Small-Size LTA's	
Summary.....	1
I-1. Current Technology Applicable to Small-Size LTA's.....	4
I-2. Conceptual Sketch Designs and Problems of Small- Size LTA's.....	29
I-2-1. Basic Planning.....	29
I-2-2. Aerodynamic Considerations.....	33
I-2-3. Studies on Hull Structure and Materials.....	36
I-2-4. Stability, Control and Propelling.....	39
I-2-5. Comparison of Rigid and Non-Rigid LTA's.....	45
I-3. Manufacturing and Operating Costs of Small-Size LTA's..	64
I-3-1. Price of a One-Ton Payload Rigid Airship.....	64
I-3-2. Operating Costs of a One-Ton Payload Rigid Airship.....	64
I-3-3. Manufacturing and Operating Costs of Non-Rigid Airships.....	70
Chapter II. Technical Possibilities Concerning Large-Size LTA's	
Summary.....	91
II-1. Statistical Data.....	98
II-1-1. Size and Performance.....	98
II-1-2. View of Hulls.....	99
II-1-3. Structure and Weight Analysis of Non- Rigid Airships.....	100
II-1-4. Structure and Weight Analysis of Rigid Airships.....	103
II-2. Performance.....	126
II-2-1. Buoyancy and Its Moment.....	126
II-2-2. Performance Evaluation.....	128
II-2-3. Performance of a Prototype Airship.....	129
II-3. Aerodynamics.....	138
II-3-1. Stability.....	138
II-3-2. Control Characteristics.....	147
II-4. Operational Feasibility.....	154
II-4-1. Specification of Operating Costs.....	154
II-4-2. Operating Costs of a Prototype Airship.....	156
II-5. Conclusions.....	170
Chapter III. Survey on Demands for LTA's	
Summary.....	173
III-1. Survey via Interviews.....	181
III-1-1. Demands for Small-Size Craft.....	181
III-1-2. Demands for Large-Size Craft.....	221

III-2. Quantitative Predictions Concerning the Demands.....	235
III-2-1. Small-Size Craft.....	235
III-2-2. Large-Size Craft.....	241
III-2-3. Demands for Use as Cargo Handling Means.....	256
Chapter IV. Overall Evaluation	
Summary.....	257
IV-1. Criteria of Judgments.....	262
IV-2. Overall Judgments on Small-Size LTA's.....	264
IV-2-1. How Excellent Are They As Industrial Tools in the Air ?	264
IV-2-2. To What Extent Can They Satisfy the Industrial Requirements ?	277
IV-2-3. To What Extent Can They Satisfy the Social Requirements ?	279
IV-3. Overall Judgments on Large-Size LTA's.....	283
IV-3-1. How Excellent Are They As Industrial Tools in the Air ?	283
IV-3-2. To What Extent Can They Satisfy the Industrial Requirements ?	293
IV-3-3. To What Extent Can They Satisfy the Social Requirements ?	294
Chapter V. Future Tasks and Proposals.....	299
Appendices: Overseas References and Chronological Tables...	301

These survey studies are summarized as follows:

/11

- (1) There will probably be considerable demand in Japan for conventional-type small-size LTA's for observation, monitoring, advertisement and other purposes. They are, however, probably not worthy objects of governmental investment in technological developments. If any governmental investment is under consideration, it should be the provision of aid for the completion of operating conditions and establishment of stable operations for LTA's.
- (2) Ultra-large-size rigid airships (with 500-ton class payload) must be considered for development, since future air cargo transportation is predicted to exceed one million tons per year and to reach the level of several millions of tons per year.
- (3) LTA's are theoretically inevitably inferior to the conventional fixed- and rotary-wing aircraft (which are both HTA's) particularly in maneuvering performance. Therefore, in the

future development of LTA aircraft, technological development which will produce significantly improved maneuvering performance must first be considered.

- (4) Cargo handling LTA systems using captive balloons promise both technological and economical possibilities.
- (5) There are probably demands for air transportation of heavy materials with weight exceeding the limit of the conventional rotary-wing aircraft.

The results of the past studies which are summarized above will be described in the following in greater detail:

I-3-2. First Survey Study.

The overall framework of this survey study is shown in Fig. I-8. (The table of contents of the report of this first survey study appeared on the previous pages.)

In this survey, by small-size LTA is denoted an airship-type LTA with a payload of less than 10 tons. Similarly, by large-size LTA is denoted an airship-type LTA with a payload of more than 100 tons. For cargo-handling LTA's, captive-balloon-type LTA's were considered. In this first survey, only an introductory survey was done for the cargo-handling LTA's. Further study of these was postponed until the second survey.

One might have noted that in the first survey middle-size LTA's with 10 to 100-ton payload were not treated, but only small- and large-size LTA's. The reason for their exclusion is as follows: With respect to scheduled flights (both passenger and cargo flights), the payload of conventional HTA's, in particular of fixed-wing aircraft, is around 10 to 100 tons. In this area, specifically, conventional HTA's have established unsurpassable superiority. Ordinary LTA's have very little chance to surpass conventional fixed-wing aircraft with respect to speed, maneuvering performance, and other points. This fact itself was discovered in the course of the first survey study. Thus, middle-size LTA's with 10 to 100 tons payload were excluded as objects of study.

- (a) Small-Size LTA's (Airships with a Payload of 1 to 10 Tons, a Gas Capacity of 10 Thousand m³ or Less and a Total Length of 100 m or Less).

With regard to social demands, we find that there is a large demand for LTA's for use in observation and monitoring. LTA's can stay in the air for long period of time and can descend to very low altitudes. Furthermore, they create no noise. These features may almost never be provided by conventional small-size aircraft or helicopters. In particular, the functions of LTA's will be invaluable in the case of a huge disaster such as a large-scale fire or earthquake.

<p>OBJECT</p> <p>CRITERIA OF JUDGMENTS</p>	Small-Size LTA	Large-Size LTA	Cargo-Handling LTA (Large)
<p>(1) How Excellent Are They As Industrial Tools in the Air ?</p> <ul style="list-style-type: none"> Function Safety Economical Efficiency Ground Facilities Operation Utilization 			
<p>(2) To What Extent Can They Satisfy the Industrial Requirements ?</p> <ul style="list-style-type: none"> Development Cost Demand Manufacturing Techniques Technological Impacts 			
<p>(3) To What Extent Can They Satisfy the Social Requirements ?</p> <ul style="list-style-type: none"> Energy Conserving Natural Resource Conserving Airport Land Noise Air Pollution 			

Fig. I-8. Framework of Survey Study.

According to the evaluation method which was introduced in the previous section, "Basic Functions of Various Types of Aircraft," advantages along the A- and B-axes are to be sought in LTA aircraft. Namely, the HTA aircraft which may compete with LTA aircraft in the fields of monitoring and observation are aero-commander-class small-size fixed-wing aircraft (with 5-hour endurance flight time, 1850-km endurance flight distance and 320 km/hour speed) or helicopters. The fixed-wing aircraft are considerably inferior in their capacity for vertical movement (designated by the A-axis). (See Fig. I-9)

On the other hand, helicopters are notably poor in endurance flight time (C-axis) and distance (D-axis). Therefore, it is conceivable that small-size LTA's (airships or captive balloons, may be superior in the areas of observation and monitoring. Quite recently, over-the-sea surveillance in order to prepare for the 200-nautical mile (360 km) economic territorial water era has attracted much attention. The Maritime Safety Bureau has a new consolidation plan, in order to establish "the adapting organization for the new nautical order." This plan includes one cruiser carrying

helicopters, five 350-ton class cruisers, two 30-meter class high-speed cruisers, one large-size airplane (YS-11), one middle-size airplane (Skyban) and one middle-size helicopter (Bell 212). It is very likely that small-size LTA aircraft may be used in this field.

There is no particular difficulty in building a small-size LTA (an airship or a balloon). A non-rigid structure is sufficient for this type of aircraft. However, there were several unsuccessful examples. Highly reliable operation is possible only with a reinforced organization or system for operation. Non-rigid airships of the U.S.A.'s Goodyear Company have carried a total of about one million passengers during the past 45 years and have ex-

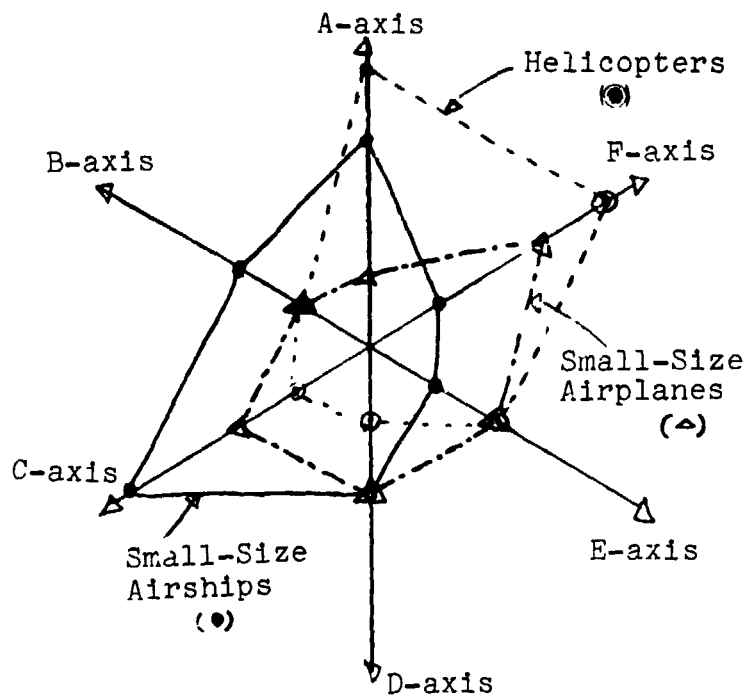

Fig. I-9. Advantages of Hybridization.

ORIGINAL PAGE IS
OF POOR QUALITY

(b) Large-Size LTA's (Airships with 500 to 1000-Ton Payload, 250-Thousand-m³ or Less Gas Capacity, about 550-m Total Length and 110-m Maximum Diameter).

When international air cargo transportation attains the level of 1,500 to 5,000 thousand tons per year, giant airships as cargo aircraft will be indispensable. (Cf. The Transportation of 5,000 thousand tons corresponds to the total imported and exported cargoes carried by container-ships in 1973.) For example, if such airships are used in Pacific liners, one can expect an economical effect which would be equal to that of railroad systems established through the Pacific Ocean.

The use of giant airships is advantageous with respect to the three criteria: vertical movement ability (A-axis), mass and heavy cargo transportation ability (B-axis) and long endurance flight time (C-axis). (See Fig. I-11.)

Even if the conventional jumbo jet aircraft were scaled up to the class of 200-ton payload, if the international air cargo transportation level reaches the level beyond one million tons per year, it would be very difficult to require HTA aircraft to play a main role in air cargo transportation, due to the anticipated noise, air pollution and airport problems. Although giant airships travel at a low speed - 100 to 150 km/hour - , they will be able to be used in cross-Pacific lines because of their long endurance time. (Cf. Tokyo to Honolulu is about 6,500 km, while Honolulu to Los Angeles is about 4,000 km.)

Assuming that the current international lines in Japan have a demand for 1,000-kilo-ton-per-year air cargo transportation, 26

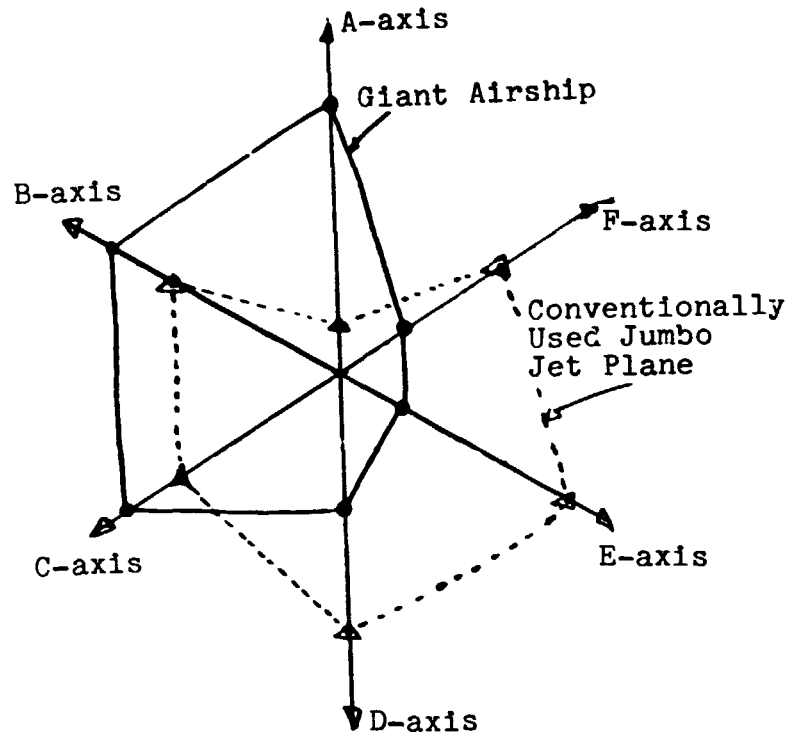

Fig. I-11. Advantages of Hybridization of Giant Airships.

Keihin-Jima 2-Chōme

ケihin-jima

2

70

Bay of Tokyo

ORIGINAL PAGE IS OF POOR QUALITY

Haneda Airport
Airport
1-Chōme

International
Airport
3500m

Haneda Airport 2-Chōme

2000m

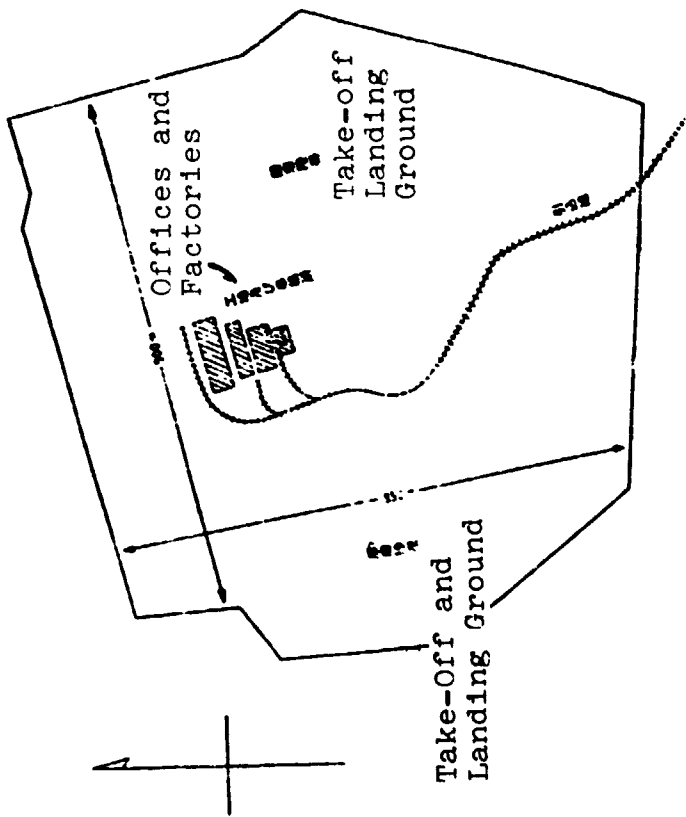

Fig. I-12. Comparison of Airport Land Use
(Left: Friedrichs Hafen - an airport for airships,
Right: Haneda International Airport)

giant airships with 1000-ton class payload would be necessary to meet the demand. There is no doubt that these large-size LTA's are a much more energy-conserving means of transportation than the currently used large-size HTA's. In order to transport a 1,000-ton cargo over the Pacific Ocean, a 100-ton payload jumbo jet (Boeing 747) consumes 75 billion yen per year for fuel. On the other hand, a 1000-ton payload giant airship will consume only 17 billion yen per year for fuel. Based on the types of engines planned for use in giant airships, it is estimated that those airships will not cause more noise or air-pollution than the currently used large-size HTA aircraft. Furthermore, the VTOL ability of the airships would decrease the area which is contaminated by the noise pollution. /16

Similarly, the airport area required by the airships is much smaller than that of conventional HTA's, owing to the VTOL ability of the airships. About a 1000m x 1000m area will be sufficient for a take-off and landing ground for airships which load and unload cargo at a pace of one to two million tons. (See Fig. I-12.)

I-3-3. Second Survey Study.

The second survey study covered technical studies concerning cargo-handling LTA's. These topics were not dealt with in detail in the first survey study; their treatment was postponed until the second survey study. In addition, the second survey included: a study of the ground facilities which would be required when LTA aircraft, in particular airships, were in operation; laws which control their operation; organizations which are necessary for their operation.

In principle, the second survey study was intended to cover the works unfinished by the first survey study. The outline of the second survey study is shown in the following "Table of Contents" of the report of this survey:

SURVEY STUDY ON LTA AIRCRAFT SYSTEMS - SECOND SURVEY STUDY	
TABLE OF CONTENTS	
Abstract.....	1
Chapter I. Survey on Small-Size LTA's for Use in Urban Areas..	9
Summary.....	9
I-1. Survey on Potential Demands via Hearing.....	11
I-2. Conceptual Sketch Designs and Problems of Small-Size LTA's for Use in Urban Areas.....	18
I-2-1. Captive Balloons.....	21
I-2-2. Unmanned Airships.....	21

(i) Features Required of Unmanned Airships.....	21
(ii) Hull Scale.....	22
(iii) Engines.....	22
(iv) Control.....	23
(v) Ground Facilities.....	24
(vi) Costs of Development and Manufacturing.....	24
(vii) Operating Costs.....	27
(viii) Summary and Problems.....	27
I-2-3. Manned Airships.....	29
(i) Features and Design Procedures Required of Manned Airships.....	30
(ii) Weight of Each Part of the Hull.....	33
(iii) Hull Shape and Scale.....	33
(iv) Stability and Maneuvering Performance.....	33
(v) Manufacturing Cost.....	36
(vi) Operating Cost.....	36
I-3. Organization for Manufacturing.....	39
I-3-1. Possibilities of Manufacturing in Japan.....	39
I-3-2. Problems in Importing Airships.....	39
I-4. Conclusion.....	40
Appendices to Chapter I.: On the Development of Small- Size LTA's.....	43
(1) Need for Multiple Approaches.....	44
(2) Price Image of Manned Non-Rigid Airships.....	45
(3) Need for Experimental Manufacturing of Conventional Type Manned Non-Rigid Airships.....	47
(4) Organization for Manufacturing Non-Rigid Manned Airships.....	48
(5) Organizations in the U.S.A. for Manufacturing.....	49
(6) What Is Lacking in Manufacturing Organizations in Japan ?	50
(8) Social Basis for Possible Airship Industry in Japan.....	51
(9) Concluding Remarks on Development of Small-Size LTA's.....	51
(10) Conclusions to Chapter I and Its Appendices.....	52
Chapter II. Survey on Ground Facilities.....	55
Summary.....	55
II-1. Base for Small-Size LTA's.....	55
II-2. Base for Large-Size LTA's.....	57
II-3. Ground Facilities Currently Used for Small-Size LTA's.....	61
II-4. Historical Development of Ground Facilities for Large-Size LTA's.....	69
II-4-1. The Era When Only Hangars Were Used (1900 to 1909).....	69
(1) On-the-Lake (Water) Hangars (1900 to 1909)....	69
(2) On-the-Ground Hangars (1909 to 1911).....	70
(2-a) Captivation (Mooring) and Transfer by Man Power (1909 to 1911)...	70
(2-b) Rail and Trolley Systems (from 1911)...	70
(2-c) Revolving Double Hangar(1914 to 1918)...	71

(2-d) Three-Wire Systems.....	71
II-4-2. Appearance of Mooring Mast (1919 to 1939).....	71
(1) High Mast Mooring System (1919 to 1929).....	71
(2) Low Mast Mooring System (1927 to 1939).....	74
(3) Mooring Systems on Ships.....	80
II-4-3. Mooring Systems for Small-Size Non-Rigid Airships During and After World War II.....	81
II-4-4. Hangars for Large-Size Rigid Airships and Their Internal Structures.....	83
II-4-5. Photographs and Graphs for Reference.....	84
Chapter III. Organization and Laws for LTA Operation.....	107
Summary.....	107
III-1. Current Status of Operation Organizations in Various Countries.....	108
III-1-1. Case of Goodyear Company, U.S.A.....	108
III-1-2. Case of WDL Company, West Germany.....	110
III-1-3. Cases in Japan - Operation of JA 1001 and JA 1002.....	111
III-2. Desirable Operation Organization in the Near Future in Japan.....	112
III-3. Survey on Laws Concerning Operation.....	115
Chapter IV. Survey on Technological and Economic Possibilities of LTA's for Cargo Handling.....	125
Summary.....	125
IV-1. General Survey of Balloons.....	128
IV-1-1. Survey on Potential Uses of Balloons.....	129
IV-1-2. Technical Survey on Design, Manufacturing and Operation of Balloon Systems.....	140
IV-2. Studies on Balloon Cargo-Handling Systems.....	140
IV-2-1. Possibilities of Balloon Cargo-Handling Systems.....	144
IV-2-2. Concept of Balloon Cargo-Handling Systems.....	146
IV-2-3. Cost Estimation of Balloon Cargo- Handling Systems.....	154
IV-3. Future Tasks Concerning Balloon Cargo-Handling Systems.....	160
References.....	163

(a) LTA's for Cargo-Handling.

In the course of the first survey, it was found that LTA systems for cargo-handling attracted a large demand from potential users. For cargo-handling LTA's, a large suspending ability is required, but excellence in speed and in travelling distance is not required. (For example, the speed of ground-transportation large-size tractors is about 5 km/hour and, in most cases, the travelling distance is about 50 km.) Therefore, balloons are more adequate as cargo-handling LTA's than airships. The second survey

study was carried out based on the above-mentioned findings.

At first, results of overseas studies concerning cargo-handling systems using balloons were collected. Then, a survey was made on the harbor conditions in the Middle East and Africa, areas which are thought to be the most promising future market of such cargo-handling systems. Many harbors in these areas suffer from congestion. Furthermore, many harbors are presently under construction in these areas.

As a result of these studies, a conceptual sketch design was made for a cargo-handling system using a balloon (7000 m³) which can suspend a three-ton cargo. In this system, the initial investment is relatively small compared with the construction cost of a pier or the like. Moreover, the operating cost for cargo unloading is estimated to be almost the same as, or less than, the cost of a crane system on a quay.

The Japan Society of Aeronautic and Space Industries has already begun studies on the practical uses of such systems, based on the above-mentioned results. A report in some form is expected to appear late in March, 1978.

In the process of the survey study of the cargo-handling LTA's, a survey study on captive balloons themselves was done with respect to their uses, performances and other points. This study is summarized in Table I-1.

(b) Domestic Production of Small-Size LTA's for Use in Urban Areas.

A study was done on the question of how to put into effect a plan for the manufacture in Japan of small-size LTA's of the type most easily built among all LTA aircraft. Two proposals were made, one for semi-rigid airships and the other for non-rigid airships. In the first survey, a conceptual sketch design was made for a rigid airship and the price of a 1-ton payload airship was estimated at one billion and fifty million yen. Similarly, in the second survey, a cost estimation was made for semi-rigid airships and the possibility of cost reduction was studied.

The following conclusions have been obtained: The manufacturing cost for a 1-ton payload airship was estimated to be about 700 million yen. Since the manufacturing cost of a non-rigid airship is 200 to 300 million yen, commercial aircraft in the near future should definitely be of the non-rigid type. However, insofar as the airships are limited to non-rigid type, no significant improvement can be expected in their sluggish maneuvering performance. Hence, it was concluded that an "advanced type" of LTA must be studied in the future so as to attain high overall performance.

Table I-1. Uses of and Requirements for Captive Balloon Systems.

Uses	Operating Altitude	Endurable Wind Speed	Payload	Shape	Requirements Peculiar to the Type of Use	Reasons
Cargo-Handling	Low	Less Than 11 m/s (Wave Height: Less Than 1.5 m)	Less Than 3 tons (Mostly Miscellaneous Goods)	Heart or Stream-line Shape	Cargo-Handling Distance= 500 m Efficiency= 9 tons/hour Cargo-Handling Cost= Less Than 3,000 yen/ton System Construction Cost= Less Than 1.5 to 2 billion yen Lifetime= More Than 5 years	Resource Conserving. Alleviating Harbor Congestion. Providing Cargo-Handling Service to Harbor Without it.
Lumber Collecting	Low	Less Than 15 m/s	1.5 ton Lumber	Heart or Stream-line Shape	Slope=30° Lifetime= More Than 5 years Lumber-collecting in an equilateral triangular area with 1-km sides is desired. Deforestation= 30-50% Selective Chopping in 250-m ² area per each 1 ha.	Environment Conserving.
Meteorological Observation	1,000 m	10 m/s	4 to 5 kg Observation Equipment	Stream-line Shape	Ascending Speed = 240 to 300 m/min Lifetime= 3 years Operation= Sent-up 6 times per Year, One Operation Every 3 Hours, One-Hour Observation 3 Hours per day, Collecting Average Data over 10-min Period.	
Emergency Warning	3,000 to 6,000 m	About 30 m/s	6 to 7 tons Radar System	Stream-line Shape	Power Consumption= 30 to 60 KVA Radar Resolution= 0.5 n.m. Radar Covering Area= 90 n.m. (30KVA)..Low Altitude 180 n.m. (60KVA).High Altitude	
Communication/Command Relay	Desired Altitude	About 30 m/s	200 to 300 kg Commu-	Stream-line Shape	The altitude and the carrying differ depending on the situation, such as kind of disaster or strategy in mission.	Resource Conserving

Remark: Among potential uses other than those listed above, the following can be considered: scientific observation of air or sea pollution, assistance in construction or civil engineering work, detection and/or monitoring of the movement of a fire, disaster or enemy, and electronic communication/information-collecting.

(c) Survey on Ground Facilities.

Current and historical data were collected with regard to not only the land necessary for airports but also for hangars, mooring towers (masts), mooring vehicles, etc. The facilities for on-the-water (sea) mooring and the construction sites were also surveyed.

(d) Laws Concerning Operating Organization.

Currently operating organizations in Japan, the U.S.A. and West Germany were surveyed. A study of laws pertaining to operation was limited to a consideration of those laws existing in Japan. As a result of this study, it became clear that the operating organization is relatively poor in Japan compared to that of the U.S.A. or West Germany.

CONTENTS

II-1. Definition and General Information about Hybrid LTA.....25(22)
II-2. Reasons Why Hybrid LTA Are Targets for Development.....30(27)
II-3. Matching of Needs and Seeds.....31(28)
II-4. Selection of Specific Aircraft Models.....32(29)

II-1. Definition and General Information about Hybrid LTA.

The original meaning of the word "hybrid" is "mixed-breed" or "cross." In the past, the term "hybrid" generally referred to the hybridization of dynamic lift and static lift (or buoyant lift).

According to the original meaning of the word "hybrid," however, various combinations can be said to constitute "hybrids" other than merely the hybrid of LTA and HTA. For example, a semi-rigid airship may be called a hybrid of non-rigid and rigid airships.

Thus, for the sake of future development, extension or re-examination of the concept of "hybrid" may be useful. Among the extended concepts is a hybrid of different kinds of gas used by airships. A combination of two kinds of gas may be considered, for example, a gas which is contained permanently, such as, Helium, with a gas which is disposable, such as hot air or hot steam. In this example, the disposable gas can be used for controlling the lift (buoyancy). The combination of Helium and hot air has already come under consideration for recreational balloons.

According to another idea, the gondola portion is suspended by long ropes from the main body of an airship or a balloon and is controlled separately by automatic control means. This type of LTA may also be called "hybrid" in a wide sense. Thus, it was decided that it be included in the present survey study on hybrid LTA's.

Hybrid LTA's which have been proposed in various countries of the world are summarized in Fig. II-1. (This is a citation from "Evaluation of Advanced Airship Concepts," by Bruno A. Joner and John J. Schneider, Boeing Vertol Company, U.S.A., AIAA Paper No. 75-930.)

In the classification in Fig. II-1, "hybrid LTA" denotes a combination of LTA and HTA, that is, a hybrid aircraft using a combination of dynamic and static lifts. (Cf. This type of LTA is called "advanced type" in English.)

In Fig. II-1, hybrid LTA's are classified into STOL type and VTOL type based on their take-off and landing mode. Then, both STOL and VTOL types are classified into the type using fuselage (main body)

lift and the type using other forces (for example, lift rendered by auxiliary wings.)

Figs. II-2 and II-3 show sketchy views of the proposed hybrid aircraft which have designed shapes recognizable in some way. (The ones whose shapes are unclear are excluded.)

According to this classification, "lifting body system" denotes a system in which the dynamic lift drag ratio of the aircraft body (fuselage) is maximized. This type of system usually has a flat shape like a disc, in order to gain as much lift as possible while maximizing the volume of the gas tanks containing the buoyant gas. Aereon Dynairship is representative of this type.

/23

On the contrary, the Megalifter-type aircraft is that in which fixed wings are attached to an airship. In the present classification, this type is classified under auxiliary wing systems.

On the other hand, hybrid aircraft combining rotary-wing aircraft (helicopters) and LTA's are classified as "combined integrated systems."

Another way of classifying hybrid LTA's is based on a combination of four types of aircraft, i.e., fixed-wing aircraft, rotary-wing aircraft, airships and balloons, as follows:

- (a) Fixed-Wing x Airship Megalifter Type..... STOL
 - Aereon Type STOL
 - Boeing
- (b) Rotary-Wing x Airship Helipsoid Type VTOL
- (c) Rotary-Wing x Airship Vanguard VTOL
 - Donut Type
(Donut-Shaped Balloon Portion)
 - Aero Crane Type VTOL
(Balloon and Wings Rotate Together.)

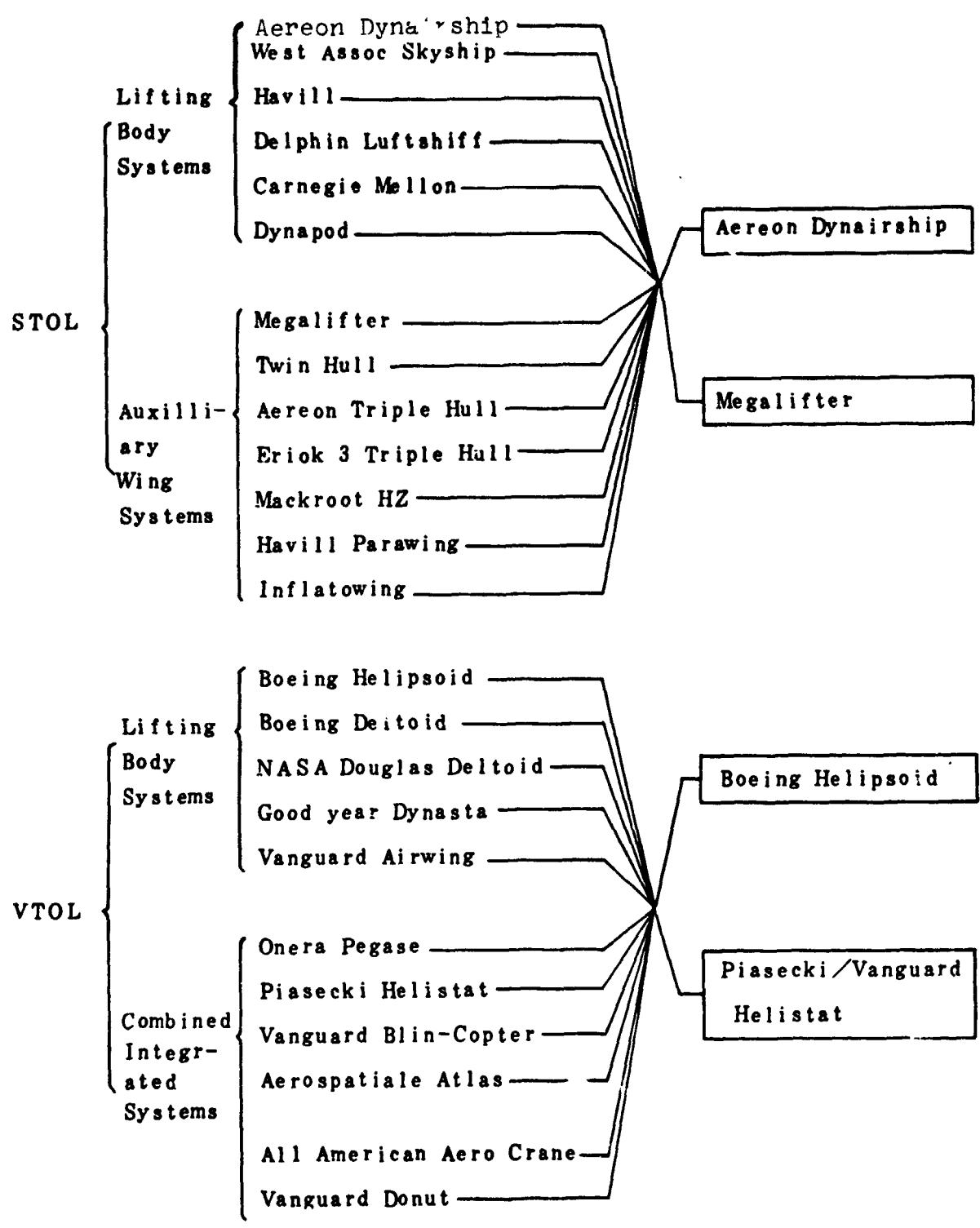
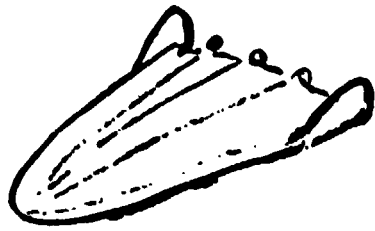

Fig. II-1. Hybrid LTA's - LTA's Which Combine Static and Dynamic Lifts



Aereon Dynairship



West Assoc Skyship

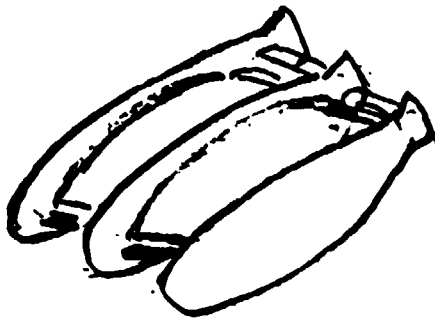

Delphin Luftshiff

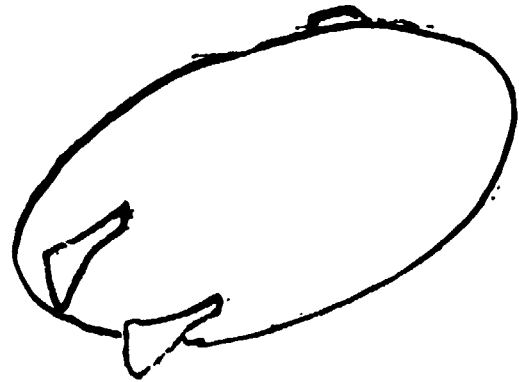

Boeing Helipsoid



Megalifter

Fig. II-2

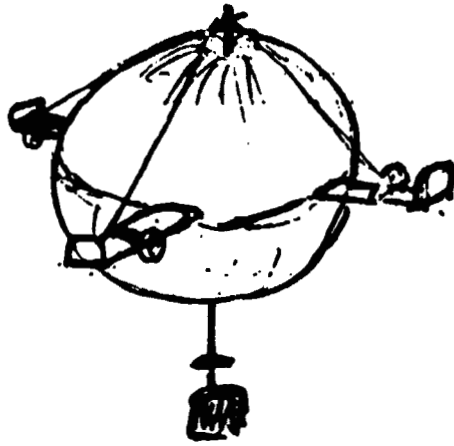

All American Engineering
Aero Crane



Piasecki
Helistat

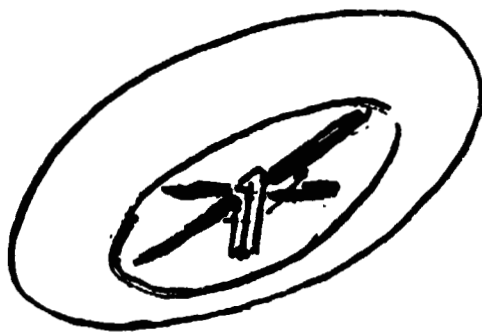

Vanguard
Donut

Fig. II-3

Why are various ideas on hybrid LTA's presently being proposed and becoming objects of study in various countries of the world? What is the background of these movements?

One motivation is an academic curiosity on the part of researchers themselves. Many ideas have been proposed by amateurs. (For example, Aereon Dynairship.) However, one should not overlook the question of social background. Specially, there are certain social requirements which cannot be satisfied by aircraft currently in use. It is expected that hybrid LTA's may satisfy these as yet unfulfilled requirements.

When those requirements unsatisfied by the HTA aircraft currently in use are judged based on the criteria which was introduced in Section I-2-1, "Basic Functions of Aircraft," one can see that the most outstanding disadvantage of the fixed-wing aircraft is related to "vertical movement ability" (A-axis). In addition, mass and heavy-cargo transportation ability (B-axis) can also be considered a function unsatisfied by these aircraft. (See Fig. II-4.)

Development of VTOL and STOL aircraft is being intensively studied at present as an extension of the current technology for HTA aircraft. This development is one of the most important objects in the present state of the aircraft sciences. The social requirement for mass transportation will be clearly shown by the future growth of the air cargo transportation.

On the other hand, rotary-wing aircraft have a disadvantage related to the B-axis direction (mass transportation ability). At present, there are only a few military helicopters of 50 to 60-ton payload class throuout the world.

With regard to the C-axis (endurance flight time), currently used helicopters have at most one hour net operating time. Their basic disadvantages resides in their inability to fulfill this function adequately. (See Fig. II-5.)

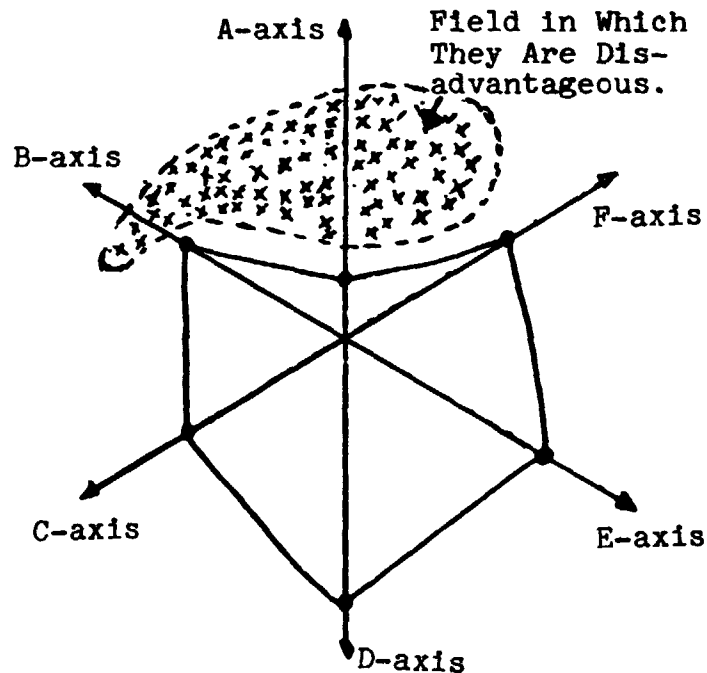

Fig. II-4. Fields in Which Fixed-Wing Aircraft Are Disadvantageous.

LTA's also have disadvantages. Their most outstanding one is related to the F-axis, i.e., poor maneuvering performance.

Within the fields of monitoring, observation, advertisement and the like, conventional small-size airships are satisfactory. Outside of these fields, however, LTA aircraft reveal serious handicaps.

Thus, it has been proposed that LTA's and HTA's be combined so as to minimize the disadvantages of both aircraft. /28

For example, the Megalifter LTA was invented with the intention of providing a means of mass transportation by equipping airships with auxiliary wings so as to attain STOL ability and also to compensate for the airships' lack of speed.

In short, this type of LTA is designed to combine the advantages of both fixed-wing aircraft and airships.

A Helistat-type LTA is a combination of a helicopter and an airship. It is intended to provide mass transportation ability and long endurance flight time, both contributions of the LTA, while improving the LTA's dull maneuvering performance by incorporating the excellent vertical maneuvering ability of the helicopter.

Air-Crane-type LTA's are intended to produce a similar result by combining balloons with rotary-wing aircraft.

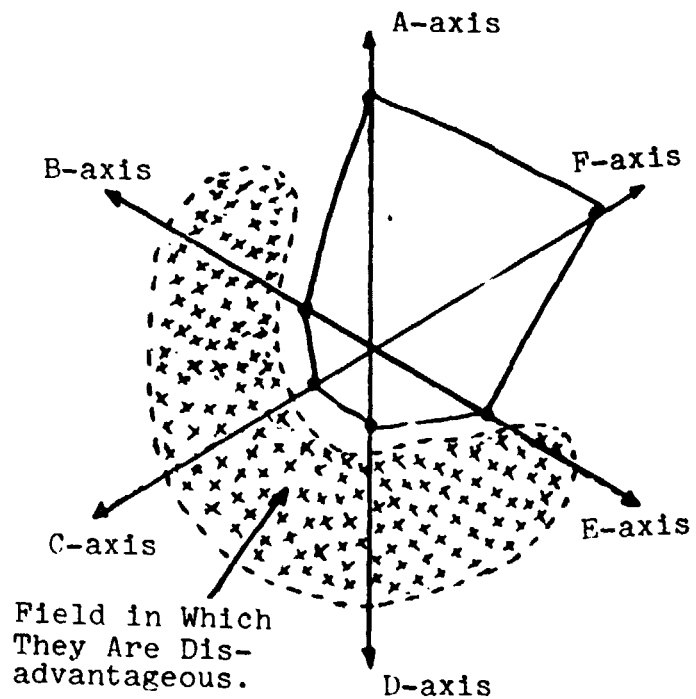

Fig. II-5. Fields in Which Rotary-Wing Aircraft Are Disadvantageous.

II-3. Matching of Needs and Seeds.

Each type of aircraft has its own disadvantages, as described above. Then, what social fields have many requirements which are not being satisfied due to such disadvantages? By discovering those fields and collecting the data on the degree of dissatisfaction resulting from the aircraft inadequacies, the appropriate scope for hybrid LTA development may be determined.

From this point of view, it should first be pointed out that that the field of air transportation of heavy materials is one of those in which dissatisfaction is felt world-wide. This is the case in Japan, too. When it comes to heavy material air transportation, nearly always, VTOL ability is required, i.e., ability to load and unload heavy cargo by vertical take-off and landing. Again, one can point out a field in which technical development is at a very slow pace compared with the pressing demands of that field: short-distance mass passenger transportation means with STOL or VTOL ability.

Keeping in mind the general background described above and the stage of research in various countries, we sought answers to the question: Where and in what forms do those social requirements exist in Japan? Our survey study focused on the subjects in which technical possibilities (we call them "seeds") match social requirements (we call them "needs"). Further, we restricted ourselves to the following fields, as those in which social requirements are urgent: (1) heavy material transportation, (2) short-distance passenger transportation, and (3) fire-fighting and air-rescue in times of disaster. /29

In addition, technical studies were done on several selected models of hybrid LTA's which had been already designed elsewhere.

II-4. Selection of Special Aircraft Models.

We first selected the Helistat-type and the Aero-Crane-type among those models of hybrid LTA's, for the objects of our study.

In addition, a fundamental study was done on Megalifter-type LTA's in order to understand their performance. A technical study was also done on the automatic pilot means of suspended gondolas as rescue and fire-fighting means in times of disaster.

The reason for our selection of the Helistat-type and Air-Crane-type is as follows: The demand for air transportation of cargoes which are too heavy for conventional large-size helicopters is expected to grow at a considerably fast rate in Japan as one type of social need. (Refer to the result of the survey on this demand, in Chapter III.)

On the other hand, when overviewing the development stages of hybrid LTA's in various countries, one can see that the Helistat-type LTA is far ahead of the others. Next come the Aero-Crane-type LTA and the Vanguard-type LTA.

The Helistat-type LTA is the most practical for actual applications due to the technical level already achieved. In addition, the Helistat-type models have a shape which is convenient both for cargo and passenger transportation means. For these reasons, we selected the Helistat-type first.

However, the original idea by Piasecki and Helistat was to

directly combine a conventional non-rigid airship with four helicopters. This structure may have the advantage that the helicopters can be disassembled and used separately. However, this causes its total price as an aircraft to be very high. Therefore, we studied a structure in which only rotor and engine portions of the conventional helicopter are attached to a non-rigid airship. (The model thus constructed is called Vanguard Blimp Copter. In this report, however, we refer to it also as Helistat-type for the sake of convenience.)

For the second object of study, we considered the Air-Crane-type and the Vanguard-Donut-type. The Aero-Crane-type LTA was selected because of its superior ability to maintain its body in a horizontal position at all times during flight. However, in order to maintain the body horizontally, the wings of the Aero-Crane-type LTA's must have vertical winglets on their ends. If the aircraft is inclined, the direction of the weight load does not coincide with the aircraft's center of gravity. Since these aircraft are intended for suspending heavy cargoes, an inclined position is undesirable. Thus, the Aero-Crane-type LTA was judged to be advantageous over the Donut-type. The All American Engineering Company, which presented the original proposal for the Aero-Crane-type LTA, published a paper which stated that Aero-Crane-type LTA may be manufactured at very low cost. The paper states that a 45-ton payload Aero Crane may actually be manufactured at about 700 million yen.

/30

On the other hand, past survey reports already suggested the possibility of the use of large-size LTA's (several hundred ton payload class) as a means of cargo transportation in the near future. For this purpose, conventional types of aircraft are also candidates. However, it is very possible for hybrid LTA's to also be hopeful candidates if they have good maneuvering performance and speed. For this purpose, the Megalifter-type LTA seems very promising. Thus, the Megalifter-type LTA was selected for study so as to evaluate its performance characteristics.

The gondola automatic pilot means were selected as an object for study for reasons which are somewhat different from the reasons for the selection of the three above-mentioned models. One important social requirement (need) for LTA aircraft is as a means of air rescue and disaster-prevention. These tasks are expected to be fulfilled by the LTA due to its long endurance flight time, mass transportation ability and vertical movement ability. With these points in mind, it is clear that it will be very advantageous for an LTA to have a gondola which is suspended from the main body and can travel by its own power to some extent so as to compensate for the poor hovering ability of the LTA itself. The disadvantages of the LTA will be largely improved by its having a gondola portation with high maneuvering performance. In order to study the above-mentioned possibilities, the gondola control means was selected as an object of study. In this study, the gondolas were assumed to be suspended by conventional-type LTA's. However, it is also possible for these gondolas to be suspended by new hybrid-type LTA's.

- SOCIAL REQUIREMENTS (NEEDS) -

CONTENTS

III-1. Current State of Heavy Cargo Transport and Problems at Issue.....	35(33)
III-1-1. Transport of Power Generating Equipment for Pumped-Strage Power Stations and Station Construction.....	36(33)
(a) Summary.....	36(33)
(b) Schedule and Quantity of Heavy Equipment Transportation.....	39(36)
(c) Means of Heavy Equipment Transportation and Their Prices.....	39(36)
(d) Transportation Costs.....	40(36)
(e) Costs Other Than Direct Transportation Costs.....	41(37)
(f) Product Design Divisions Requiring Increase of Transportation Ability.....	41(37)
(g) Efforts to Reduce Equipment Size and to Decompose Equipment.....	43(38)
III-1-2. Transport of Power Generating Equipment for Hydro-Electric Power Stations and Station Construction.....	46(41)
III-1-3. Transport of Power Generating Equipment for Geothermal Power Stations.....	53(47)
(a) Present State.....	53(47)
(b) Increase in Equipment Capacity for Geothermal Power Stations.....	57(50)
III-1-4. Transport Problems in Construction of Power Transmission Lines.....	60(52)
(a) Foundation Work.....	62(53)
(b) Assembling Work.....	62(53)
(c) Wiring Work.....	64(54)
(d) Summary of Transportation for Construction of Power Transmission Lines.....	64(55)
III-1-5. Transport for Construction of Power Substation...	67(57)
(a) Significance of Transportation Problems Resulting from the Rationalization Plan of the Japanese National Railways.....	67(58)
(b) Transportation of Transformers for Substations...	68(58)
III-1-6. Problems of Heavy Cargo Transport in Connection with Rationalization of the Japanese National Railways.....	86(68)
(a) Reduction of Freight Train Stations.....	86(68)
(b) Freight Train Schedule.....	86(68)
(c) Freight Cars.....	86(68)
III-1-7. Bridge Building, Penstocks, and LTA.....	87(69)
III-1-8. Heavy Cargo Transport in Dam Construction and LTA.....	89(70)

III-1-9.	Transport Data for Reference in Connection with LTA Use.....	94(74)
III-1-10.	Anticipated Annual Demand for LTA.....	95(75)
III-2.	Current State of Large-Size Helicopters and Problems at Issue.....	97(77)
III-3.	Current State of Short-Distance Aviation and Passenger Transportation and Problems at Issue.....	105(83)
III-3-1.	Problems at Issue in Short-Distance Air Transportation and Airplanes Which Are Being Sought.....	105(83)
	(a) Problems in Short-Distance Air Transportation.....	105(84)
	(b) Airplanes Which Are Being Sought and Overview of the Future State.....	108(86)
III-3-2.	Short-Distance Air Transportation in the Environs of Large-Cities.....	114(91)
	(a) Operation by New York Airways Company.....	114(92)
	(b) Operation by Air Transit Company.....	115(93)
III-3-3.	Current State of Transport to Isolated Islands and Problems at Issue.....	117(94)
	(a) Beppu/Ohita to Shin-Ohita Airport.....	122(98)
	(b) Kajiki to Kagoshima/Sakurajima to Ibusuki.....	125(100)
	(c) Niigata to Sado.....	127(102)
	(d) Hakata to Iki/Tsushima.....	135(107)
	(e) Tanegashima to Yakushima.....	135(107)
	(f) Problems in Air Transportation to Isolated Islands.....	135(107)
III-3-4.	STOL Aircraft Development in Our Country.....	141(111)
III-4.	Social Requirement for Means of Airborne Assistance in the Event of Emergency.....	150(119)

/32

III-1. Current State of Heavy Cargo Transport and Problems at Issue.

/33

Besides heavy equipment for power stations, heavy cargoes include: equipment such as reactor vessels for petro-chemical plants, heavy equipment for pulp/cement plants, machine tools, bridges, equipment for new super-express railway system construction or water-supply/sewage systems, etc. Among these cargoes, the transportation of equipment for power stations and station construction are considered first.

Recently, the scales of the power generating units have reached the level of 700 to 1,000 thousand kW per unit in modern large-scale thermal power station and nuclear power stations. Even a 1,100-thousand-kW unit was installed in a nuclear power plant. Accordingly, over-300-ton cargoes, sometimes 600 to 800-ton cargoes, have been transported to construction sites. Fortunately, the above-mentioned thermal and nuclear plants have been constructed at seaside sites. Therefore, transportation problems have been not so serious as those in the construction of inland hydroelectric plants or geothermal power plants, even though ultra-heavy equipment had to be transported. The means of transportation utilized were coastal marine transportation, on-the-sea cranes (3,000-ton maximum load) and Zinpole (800-ton maximum load). In an effort to control environmental problems, the

construction of nuclear plants in isolated mountainous areas has been recently brought under consideration. This plan is felt to be realizable by applying the civil engineering techniques which are now used for constructing pumped-strage hydroelectric plants. When this plan is more practically examined, it becomes clear that the development of new inland transportation means for ultra-heavy cargoes will be one of the problems to be solved.

With regard to electric power equipment, power transmission line equipment and power substation equipment should be also listed among the objects of transportation which may cause problems in inland transportation, as well as power generating equipment. Recently, re-organization of freight train stations and reduction of freight train services by the Japanese National Railways have caused problems even in the transportation of the under-300-ton cargoes. Consequently, inland transportation problems have become very serious not only for power generating equipment but also substation and transmission line equipment

III-1-1. Transport of Power Generating Equipment for Pumped-Strage Power Stations and Station Construction.

(a) Summary.

O Pumped-Strage Power Station is located in the north-east part of Totsu-Gawa-Mura, Yoshino-Gun, Nara Prefecture, at the center of Kii Peninsula. This station has an upper dam and a lower dam which have a 500-m difference in elevation. The night off-peak surplus power is used to pump the water from the lower strage to the upper strage, which releases the water for power generation at day-time peak hours. The location is 57-km away from Gojō-Gawa Railway Station and has only one connecting route, National Road 168. The area is one of the most thinly populated areas in Japan. (See Fig. III-1.) The power generating equipment used at this power station is:

Pump Water Wheels	207/214 thousand kW	6 Units	6,600 tons
Generator/Motors	220/214 thousand kW	6 Units	6,700 tons
Main Transformers	500 kV/680 MVA	2 Units	2,200 tons
Others			500 tons
		Total	16,000 tons

Besides the above equipment, 7,000 tons of 4.3-m maximum diameter, 50-mm maximum thickness, 800-m long penstocks are included in the heavy material which must be transported to the construction site.

The specifications of the above pump water wheels and generator/ /3
motors were discussed repeatedly with respect to the transportation conditions as well as the characteristic performances. Judging by the recent trend in the pump water wheels, 250 to 300-thousand-kW units were considered at first. In consideration of the transportation conditions for the high speed runner bodies, 207/214-thousand-kW pump water wheels were finally selected. The size reduction of the runners was also undertaken by developing runners with higher speed. As a result of an intensive study of the hydraulic characteristics of runners, a 514-r.p.m. high speed runner was developed, and consequently,

Fig. III-1 Transportation Route to O Pumped-Storage Power Station

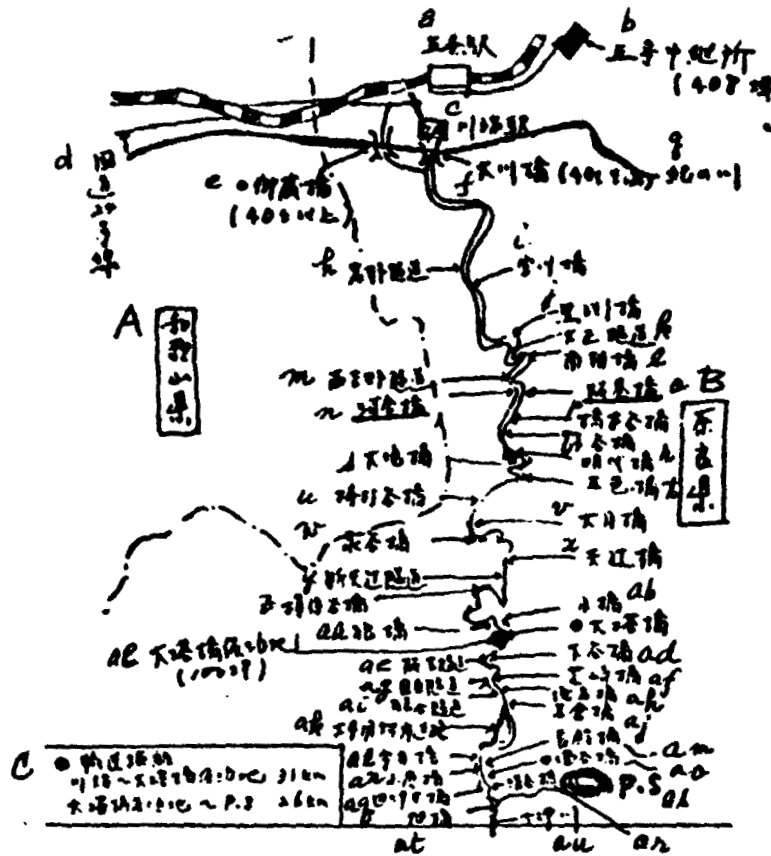

Key:

- A: Wakayama Prefecture
- B: Nara Prefecture
- C: Transportation Distance
- Kawabata-Daitōbashi : 31 km
- Daitōbashi-P.S. : 26 km
- a: Gojō Railway Station
- b: Gojō Relay Ground
- c: Kawabata Station
- d: National Road 24
- e: Mikura Bridge
- f: Ohkawa Bridge
- g: Ki-no River
- h: Iwano Tunnel
- i: Miyakawa Bridge
- j: Kurobuchi Bridge
- k: Taisho Tunnel
- l: Nancho Bridge
- m: Nishi-Yoshino Bridge
- n: Kawai Bridge
- o: Sakamaki Bridge
- p: Hashimoto-Dani Bridge
- q: Shimotani Bridge
- r: Myodai Bridge
- s: Ohtaki Bridge
- t: Goshiki Bridge
- u: Toda-dani Bridge
- v: Ohtsuki Bridge
- y: Shin-Amatsuji Bridge
- ab: Ko Bridge
- ae: Daito Bridge Rest Area
- ah: Taki-dani Bridge
- ak: Detour
- an: Ohara Bridge
- ar: Setani Bridge
- au: Totsu River
- w: Nagatani Bridge
- z: Sonpo-dani Bridge
- ac: Sakamoto Tunnel
- af: Shibazaki Bridge
- ai: Kumatani Bridge
- al: Ui Bridge
- ao: Nigori-dani Bridge
- as: P.S.(Plant Site)
- x: Amatsuji Bridge
- aa: Ohkami Bridge
- ad: Shimotani Bridge
- ag: Meziro Tunnel
- aj: Akakura Bridge
- am: Nagatono Bridge
- aq: Hizui Bridge
- at: Asahi Tunnel

Approximate
Plant Site
Position



Key:

- A: Nara Prefecture
- B: Wakayama Prefecture
- C: Mie Prefecture
- a: Nara City
- b: Gojo
- c: Shio-no-misaki

National Road 24

Fig. III-1

/35

Ohkawa Bridge

COTINUED

National Road 168

Parking Area

Daito

ORIGINAL PAGE IS
OF POOR QUALITY

Detour

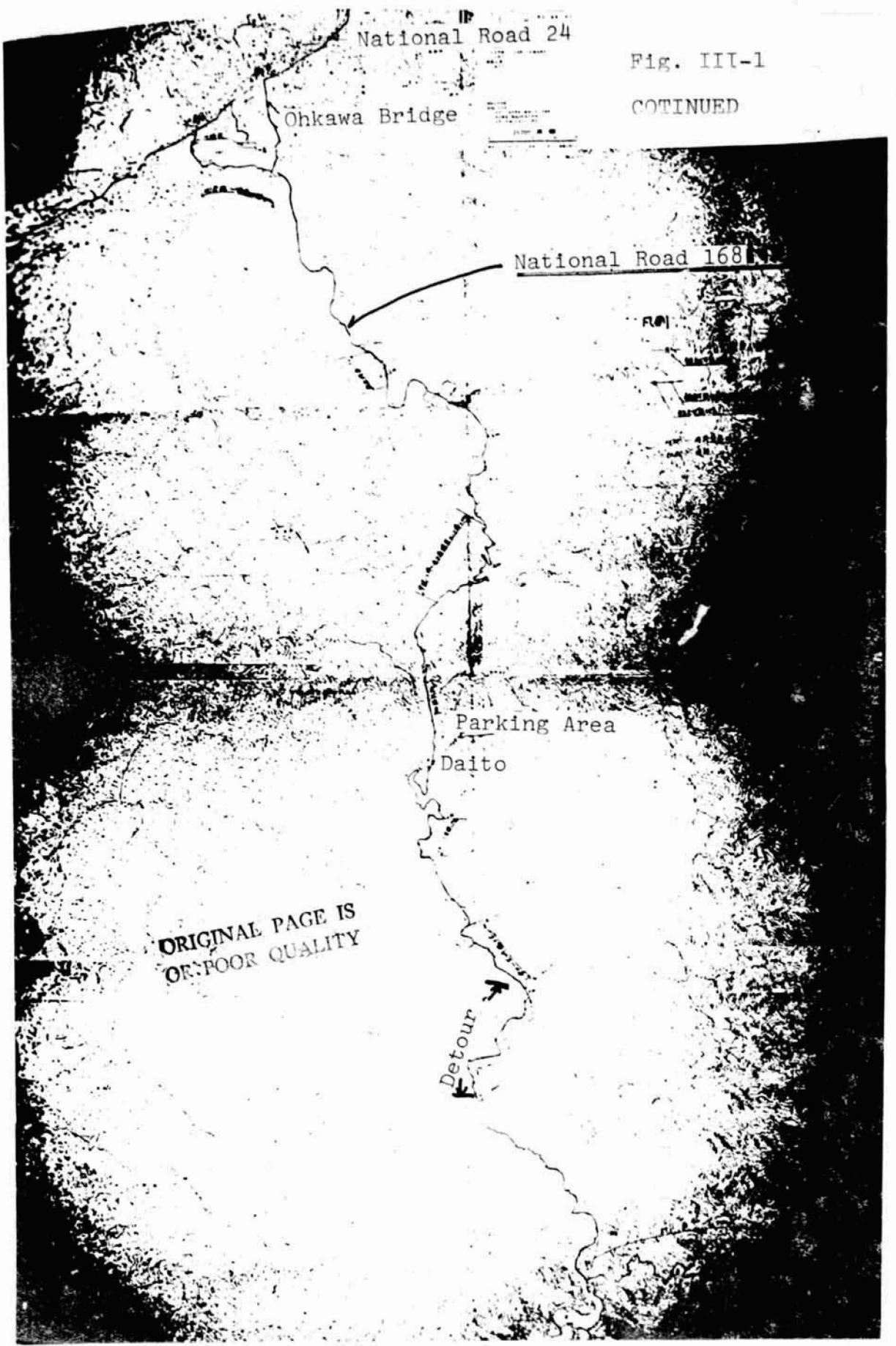

the transportation problems were solved.

The size of the cargoes to be transported are restricted to 4.1-m height and 3.2-m width, in the transportation route to this pumped-strage power station. The restriction on the weight is 50 tons. The 57-m road from the Gojō-Gawa Railway Station was re-paved and reinforced. Furthermore, reinforcement work was done on 31 bridges along the road. Seven tunnels were reshaped or enlarged. Detour routes of a 8-km total length were constructed for the construction equipment transportation. The total cost of the above civil engineering works is calculated to be approximately 1.1 billion yen.

Besides the above-mentioned selection of the high-speed runners, the design of each equipment was re-examined with respect to the transportation conditions. For example, a 500-KV/680-MVA main transformer in a decomposable form was developed for this plant construction. This transformer is a decomposable large-size transformer which was manufactured in Japan for the first time. In this transformer, each phase of main transformer portion is decomposed into three parts (nine parts in total) and attached load-time voltage regulator is decomposed into three parts. Before this transformer was developed, the maximum number of the decomposition was six. Although this transformer marked a new record, the cost was doubled. Moreover, the stator of the generator-motor was decomposed into seven parts, which was also not an easy task to achieve. The generator main Shafts, the pump water wheel main shafts and the upper and lower covers of the water wheel were also decomposed so that every piece to be transported weighted less than 50 tons.

/36

(b) Schedule and Quantity of Heavy Equipment Transportation.

The transportation work period started in January, 1977 and is planned to end at the end of 1979. During this period, 340 packages will have been transported by trailers, with capacity of 20 tons or more, as shown below:

Trailer Capacity			
20 tons	112 packages	}	3,000 tons
30	88		5,500
40	122		
70	18		1,000
	Total		9,500

The 9,500 tons are 60 % of the total transportation to the site.

(c) Means of Heavy Equipment Transportation and Their Prices.

Freight Car (650 km from the factory to Gojō-Gawa Railway Station)

Siki 550	(mainly transformers)	9 cars	630 million yen
(type No.)	(mainly stators)	7 cars	210 million yen

Trailers Used		
20 ton	2 units	20 million yen
30	2	30
40	4	100
70	1	35
	Total:	185 million yen

The above-mentioned trailers are specially designed low-floor rear-wheel-steering trailers for use on the roads in steep mountainous areas. These trailers require a special driver who operates rear-steering only. These trailers are pulled by tractors (35 million yen each). Therefore, when the trailers are used 100 % at a time, the total trailer cost, including the corresponding number of necessary tractors, is $185 + 315 = 500$ million yen. The lifetime of a trailer is four years, while that of a freight car is 12 years.

(d) Transportation Costs.

The transportation costs of trailers must include depreciation costs, motor vehicle taxes and insurance, besides fuel cost, maintenance part costs and personnel expenses. Transportation cost of a 20-ton trailer is estimated to be 130 to 150 thousand yen per day.

Transportation by freight train takes 10 days from the Tokyo-Yokohama area to Gojō-Gawa Station, and transportation through the mountains from the railway station to the power plant site takes two full days. On the other hand, the schedule when using direct trailer transportation from the Tokyo-Yokohama area to the plant construction site is:

2 full days (Tokyo-Yokohama Area to Gojō-Gawa Station)
+ 2 full days (Gojō-Gawa Station to Construction Site)
= 4 full days.

The Transportation between Gojō-Gawa Station and the construction site is restricted to the hours between 10 p.m. and 5 a.m., based on an agreement with the roadside community dealing with noise prevention and traffic control. The speed is 5 km/hour on the way there and 10 km/hour on the return trip. Thus, it actually takes the trailer three full days due to these restrictions. Furthermore, since the 57-km long mountain road is a unique route connecting Gojō and Niimiya, the trailers must pull off and wait by the side of the road when other traffic so requires, and must be strictly controlled so as to maintain road safety. To fulfill these requirements, an intermediate base was constructed as Dai-Tō Bashi, which is the middle point of the route. This intermediate base also serves as a rest area. In addition, on each trip, a guide vehicle is sent to survey the road condition and the weather (rain or snow). Therefore, actual transportation is carried out by a chain of vehicles, namely, a guide vehicle, a lead vehicle, a tractor/trailer and a safeguard vehicle which follows behind. Thus, the number of necessary personnel amounts to 30 persons, including safeguard personnel. Consequently, the transportation /37

of material which is heavier than 20 tons costs, on the average, 50 to 100 thousand yen per ton; this includes only the direct cost from the factory to the construction site by means of freight train and trailer.

(e) Costs Other Than Direct Transportation Costs.

Those costs which are not calculated into the direct transportation cost include the cost of bridge reinforcement and the cost of road repair. These are shown below (some numbers are estimated values.):

Reinforcement of Oh-Hashi (a bridge)	150 million yen
Reinforcement of Ko-Bashi (a bridge)	75
Construction of Detour Roads (8 km)	300
Security Maintenance of the Prefecture Road	500
Reinforcement and Repair of Under- ground Pipes and Cables (e.g., water or gas pipes)	20

Including other costs, such as maintenance and repair of the road surface and shoulders, the total cost is estimated at about 1.1 billion yen. It is generally said that 4 to 5 % of the total cost of power plant construction is spent on transportation. In this case, therefore, the expenditure of about three billion yen for transportation can be thought of as an adequate level. With regard to reinforcement of bridges, there are special problems related to local communities. For the construction of this plant, temporary bridges were constructed (Kawai and Sakamaki Bridges). An agreement was made with the local community that these two bridges would be removed immediately after the completion of construction so as to prevent flood. It was further agreed that the rainy seasons and the typhoon season would be avoided, and that all available manpower would be used in order to concentrate the work of trailer transportation into a short period of time, so as to avoid danger and to reduce the amount of necessary reinforcement work.

Accordingly, the transportation cost borne by the maker, including these costs other than the direct cost, is about 50 % of the direct transportation cost. The corresponding cost borne by the user will be 200 to 300 %.

For these reasons, probably an adequate estimate of the cost to the user of transporting materials heavier than 20 tons is 150 to 450 thousand yen.

(f) Product Design Divisions Requiring Increase of Transportation Ability.

The runners used in O Pumped-Storage Hydroelectric Power Station are 380cm x 295 cm x 303cm in size and 39 tons in weight. The outer diameter of the runner is 380 cm. In order to meet the transportation restriction of 4.1-m height and 3.2-m width, the runners are transported on the trailer platform in an inclined position.

The unit capacity of pump water wheels was at the level of 100 thousand kW from 1965 to 1974. Since that period, the capacity of power systems has been increased, and pumped-strage power stations of larger scale have been constructed. Due to this tendency and to economizing efforts, the unit capacity of pump water wheels has been rapidly increased. Today, many pumped-strage power plants have a million KW class capacity.

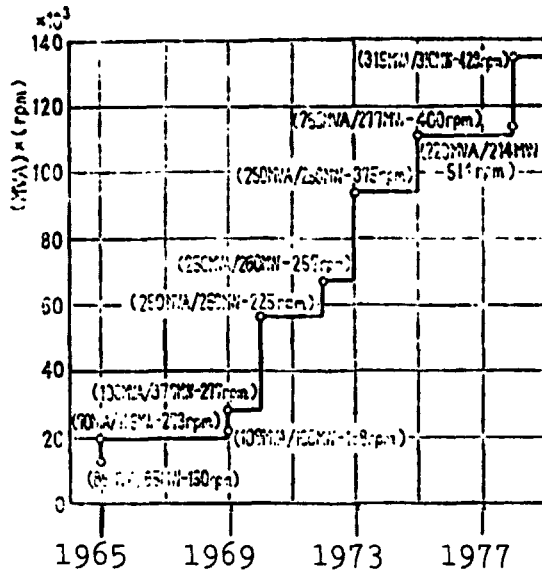

Fig. III-2. Growth of Speed and Capacity of Generator-Motors Produced in Japan.

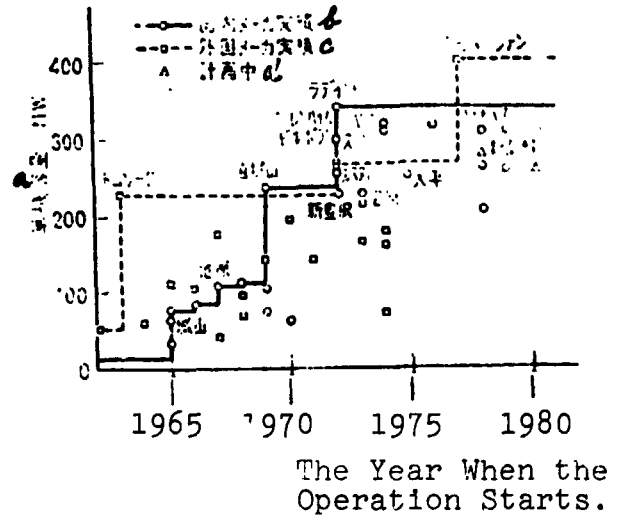

Fig. III-3. Transition of the Unit Capacity of Pump Water Wheels.

Key: a: Unit Capacity (MW)
 b: Achievement by Domestic Makers
 c: Achievement by Foreign Makers
 d: Planned

As seen in Figs. III-2 and III-3, Japan has recently entered the era when pump water wheels with 250 to 300 thousand-kW unit capacity are being manufactured. In order to reduce the construction cost of pumped-strage power plants, it is most efficient to provide great water-fall height by constructing two strage ponds with great difference in altitude. This will produce high power with a smaller quantity of water, reduce the capacity of the strage ponds and reduce the number and the size of necessary equipment. For these reasons, the water-fall height of the pumped-strage power plant has been increased in Japan. This achievement is also due to the efforts of makers in Japan to develop the required equipment. Thanks to these efforts, water-fall height in Japan is now greater than in other countries, as shown in Fig. III-4. The equipment for great pumping-up height is now exported to foreign countries by makers in Japan. Accordingly, cost

reduction by great pumping-up height is now a world-wide trend. Pumping-up height as great as 1,000 m is now under consideration.

In Japan, however, in order to realize a great pumping-up height, power station sites must be located along rivers in deep mountainous areas. This is necessary along with the scaling-up of the pump water wheel unit capacity. Accordingly, the transportation required for power plant construction becomes more difficult and more costly. In order to reduce the construction cost, reduction of the transportation cost becomes thus essential. Thus, present tasks include finding more efficient methods for constructing roads, improving transportation means, developing novel transportation means and new types of equipment and reducing or decomposing equipment, and thereby, achieving a more rationalized transportation system for power plant and transmission line equipment and construction materials.

In case of O Pumped-Storage Power Plant, it is estimated that 40 % of the total cost is spent on civil engineering work, 30 % on electrical work and 30 % on land compensation, interest and miscellaneous expenses. This last fraction includes the 4 to 5 % road-related cost and 1 to 1.5 % transportation cost.

(g) Efforts to Reduce Equipment Size and to Decompose Equipment.

With regard to decomposition of equipment, the decomposition of the main transformer into nine parts caused the cost to be doubled. Likewise for other equipment, the cost will be increased by 10 to 15 % per one decomposition. Furthermore, there is a technical limitation for the decomposition of equipment.

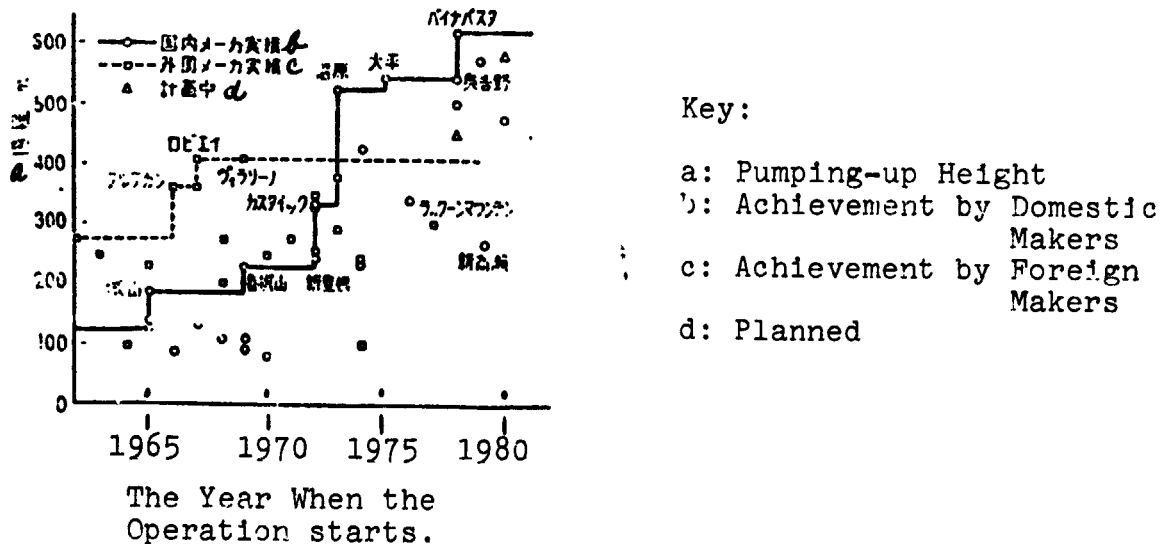

Fig. III-4. Transition of Pumping-up Height of Pump Water Wheels.

Decomposition of a pump water wheel runner is one object which has attracted attention. In this case, a decomposed runner which can be assembled and used at a high speed is a current technical goal. Such a runner must endure the great centrifugal force which may be applied in a plant with a great pumping-up height. Recently, a decomposed runner was incorporated into a 425-m pumping-up height equipment. However, if one can develop an integrated runner which can be used at high speed and is small in size, such a runner will solve two problems at once, namely, the problems of equipment cost reduction and transportation to the construction site.

In the case of OY Pumped-Storage Power Station, whose construction has recently been scheduled, a 240-r.p.m. pump water wheel runner was selected and decomposition was thought to be necessary in the early stage of planning. Later, however, a 300-r.p.m. integrated runner was developed which enabled both the reduction of the equipment and of the transportation cost. Nevertheless, if new transportation means using LTA's were developed, they might offer new possibilities for the construction of large-capacity power plants. If such a plan were to be carried out, the amount saved on construction cost by using high-speed, high-capacity integrated runners could be invested to develop new means of transportation. In Table III-1 which shows current plans of pumped-storage power plants, one can see that the unit construction cost varies from 50 to 128 thousand yen per kW. If a plan is realizable, such variation would be tolerable up to 250 %. Therefore, there is a possibility that a huge amount can be invested in the development of new transportation means.

Hydroelectric power generation has excellent response to the peak power demand, and therefore, is a very efficient means for storage of the electric power and its optimal use. It is said to be adequate for common hydroelectric and pumped-storage power plants to cover 20 % of the power demand increase. According to this figure, 1.14-million-kW-per-year hydroelectric plants should be constructed by 1985 and 1.2-million-kW-per-year by 1990. The estimated construction costs are 108.5 billion yen and 114.3 billion yen, respectively.

Accordingly, power plant equipment which is heavier than 20 tons would be transported at a pace of about 10,000 tons per year.

Table III-1. Construction Plans of Pumped-Strage Power Plant.

Construction Continued in 1977 Fiscal Year

Name of Company	Name of Plant	Water System	Name of River	Output (MW)	Main Transformer	Total Const- ruction Cost	Unit* Const- ruction Cost
Tokyo Electricity	Shin Takasegawa	Shinano River	Takase River	1,280	367x4	103,700	81
	Tamahara	Tone River	Hocchi River Tone River	1,200	335x4	118,300	99**
Chūbu Electricity	Oku-Yahagi 1st	Yahagi River	Kuroda River	315	126x3	101,000	92**
	Oku-Yahagi 2nd	Yahagi River	Tominaga R.	780	296x3		
Kansai Electricity	Oku-Yoshino	Shingū River	Asahi River Seto-dani R.	1,206	680x2	78,900	65**
Electric Power Development	Oku-Kiyotsu	Shinano River	Kiyotsu R.	1,000	560x2	72,900	73**
			Total	5,780		474,670	

* Unit = Thousand Yen per kW
 ** Plants Purely of Pumped-Strage Type

In Preparation for Starting Construction

Tohoku Electricity	2nd Numazawa	Agano River	Tadami River	460	242x2	48,960	106**
Chubu Electricity	Oku-Mino	Kiso River	Itadori R. Neya River	1,000	588x2	93,900	94**
Shikoku Electricity	Hon-Kawa	Yoshino River	Seto River	600	680	99,200	165**
Electric Power Development	Shimogō	Agano River	Agano River	1,000	584x2	50,300	50**
			Total	3,060		292,360	

Starting Construction Desired in 1977

Kansai Electricity	Ogochi	Ichi River	Odawara River Ohmi River	1,280	680x2	123,010	96**
- continued -							

Kyushu Electricity	Amayama	Rok-kaku R. Matsu-ura R.	Amayama River Iwaki River	600	340x2	76,500	128**
Electric Power Development	Tokuyama	Kiso River	Ibi River	400	240x2	44,400	111
Total				2,280		243,910	

Hokkaido	Takami	Shizunai R.	Shizunai R.	200	125x2	52,500	262
Tokyo	Imaishi	Tone River	Kinuta River	640	367x2	75,500	120**
Total				840		128,000	

GROUND TOTAL				11,960		1,138,940	
--------------	--	--	--	--------	--	-----------	--

Construction Plan of Pumped-Storage Power Plant	Increase in Output per Year	Estimated Total Construction Cost
1975	7,100 Thousand kW } 1,140 Thousand kW/year 18,500 Thousand kW } 24,500 Thousand kW } 1,200 Thousand kW/year	108,552 million yen
1985 (Estimated)		114,265 million yen
1990 (Estimated)		

III-1-2. Transport of Power Generating Equipment for Hydroelectric Power Station and Station Construction.

As a result of investment and operation of large-scale machine manufacturing means, manufacturing of large-scale machines has been economized. A common tendency in the world is to use larger-unit-capacity Francis water wheels in hydroelectric plants for the purpose of reducing construction costs. In Japan, due to the lack of appropriate sites for large-capacity hydroelectric plants, the record of capacity has not been updated since 1972. Based on recent developments in civil engineering techniques, a Hydroelectric Power Plant with 260-thousand-kW capacity was planned. The site of this plant is located at Wada River of the Joganji Water System in the Hokuriku District. The site is in steep mountains and transportation conditions are very poor. Strict restrictions on equipment size were set in order that the trans-

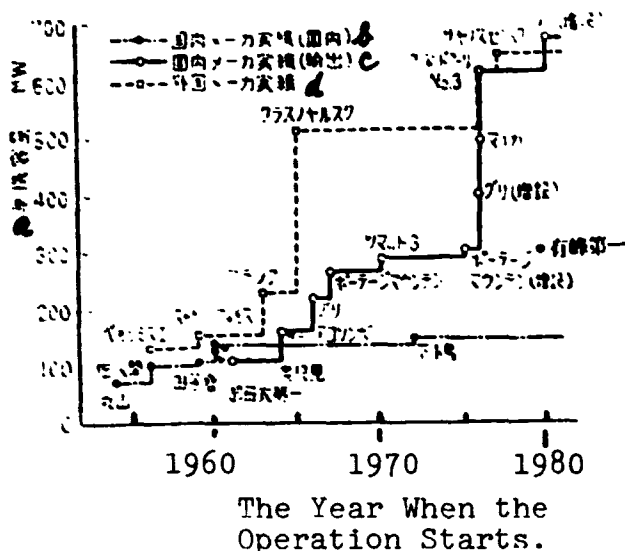

Key:

- a: Unit Capacity (MW)
- b: Achievement by Domestic Makers - Domestic Use -
- c: Achievement by Domestic Makers - Export -
- d: Achievement by Foreign Makers

Fig. III-5. Transition of Unit Capacity of Francis Water Wheel.

portation might be done through small tunnels for the purpose of reducing transportation costs. Therefore, when the equipment makers were vying for orders, whether or not they could guarantee satisfaction of these transportation requirements was among the points most carefully considered.

The number of blades of a runner used only for power generation is much greater than that of a runner for a pump water wheel. There are usually more than ten. Decomposition of such a runner is, therefore, undesirable due to its structure. Such decomposition inevitably causes the generator cost to increase by 10 to 15 %. One maker of such runners has developed a super high-speed 300-r.p.m. runner after an intensive study of hydrodynamics. This runner is a record-breaking one as this kind of means. Thus, the given transportation restriction was satisfied along with the other specifications. Besides runners, the other causes of transportation problems in hydroelectric plant construction are: upper covers, lower covers, water wheel/generator main shafts, water wheel inlet valves, generator stators, transformers, etc. In another construction site, the constructor even considered transportation of the runner by air. In the case of A Power Plant, circular-shaped tunnels are partially curved so that the water wheel inlet valves can be transported through them.

Japan seems to have many fewer sites appropriate for power plants exclusively for power generation than other countries. In Japan, however, there is still future demand for multi-purpose dams for irrigation, flood control and water resources as well as power generation. Also, the development of civil engineering techniques and the rapid rise of the price of crude oil will stimulate further utilization of water re-

sources, together with counterplanning against peak demand increase. The hydroelectric plants currently planned or under construction in Japan are shown in Table III-2.

Table III-2. Construction Plans of Hydroelectric Power Plants.

	Number of Sites	Output (Thousand kW)	Construction Cost (Million Yen)
Construction Continued in 1977	23	728.5	247,433
Construction Prepared	12	220.0	82,354
Starting Construction in 1977 Desired	16	604.6	150,171
Starting Construction in 1978 Desired	14	358.2	139,085
Total		1911.2	619,043

(including pumped-storage plants)

Construction Plans of Hydroelectric Plants of Usual Type

Increase in Output per Year

Estimated Construction Cost

1975	1.780 Million KW	} 450 Thousand KW per Year	145,748 Million Yen
1985 (Estimated)	2.250 Million KW		
1990 (Estimated)	2.650 Million KW	} 800 Thousand KW per Year	259,108 Million Yen

An inevitable general tendency is for the development sites to move into more and more mountainous and isolated areas where transportation problems are more serious.

One can see that, if air transportation of equipment heavier than 20 tons (such as power plant construction means, materials, plant equipment, etc., shown in Table III-3) were possible by means of LTA, the road-related construction cost which now occupies 4 to 5 % of the total construction cost would be greatly reduced and the preparation period for the construction of dams, temporary roads and tunnels would also be significantly reduced. The utilization of LTA's may make possible the reduction of not only transportation cost but also construction cost itself. Furthermore, it may extend the range of possible sites for plants. As seen in Table III-2, development of hydroelectric power is steadily planned - 450 thousand kW by 1985 and 800 thousand kW by 1990. The estimated costs are 145,748 million yen and 259,108 million yen, respectively. Table III-4 shows the list of the main equipment used in 260-MW A First Power Station and 12-MW A Second Power Station. It is currently estimated that the heavy materials over 20 tons are 23 packages and amount to a 724-ton total weight, for these two stations. This quantity corresponds to the annual rate of heavy cargo transportation for hydroelectric power plants.

Table III-3. Civil Engineering Machines Used
in Construction of Hydroelectric Power Plants.

/43

Heavy Dump Trucks

Maker	Model	Maximum Load	Vehicle Weight
Nissan	WD 38	38 tons	32 tons
Komatsu	MD 320-2	32	26.4
	HD 180-4	18	16.75
Hino	ZG 150D	15	14.775
Hitachi	DH 321DA	32	27.3
	DH 321EA	32	27.5
	DM 15A1	15	14.6
Mitsubishi Motors	D 200	20	19
	D 320	32	26.5

Bulldozers

Maker	Model	Fully Loaded Weight	
		Vehicle Weight	With Equipment
Caterpillar: Mitsubishi	D5 Direct	9.3 tons	11.4 tons
	Power Shift	9.6	11.7
	D6C Direct	11.25	13.85
	Power Shift	11.55	14.15
	D7F Power Shift	16.45	20.3
	Direct	16.15	20.0
	D8K Power Shift		37
Komatsu	D9H		49.25
	D50A-15	9.57	11.4

(continued)

D60A-6	12.55	15.25
D80A-12	17.31	21.54
D150A-1	26.93	32.71
D355A-1	36.10	44.41

Table III-4. Main Equipment in A First and Second Hydroelectric Stations.

/44

	H(m)xW(m)xL(m)	Number of Units	Unit Weight (tons)	Total Weight (tons)
1. Water Wheel Runners	3. x 1.8 x 5.3	2	32	64
2. Main Shafts	2.2 x 2.2 x 5.4	2	35	70
3. Inlet Valve Bodies	3.2 x 3.2 x 3.9	2	35	70
4. Inlet Valve Cylinders	3. x 3.3 x 5.	2	35	70
5. Generator Stators	2. x 3.5 x 4.	8	30	240
6. Thrust Color	2. x 3.6 x 3.6	1	30	30
7. Transformers	3.5 x 2.5 x 3.5	6	30	180
Total		23		724

Additional information regarding A Hydroelectric Plant is as follows: the location of A First Power Station is 42 km from Toyama Railway Station via Course a, 40 km via Course b, and 36 km via Course c. There are four bridges in the courses, and the longest bridge, 550 m, has difficulty with reinforcement, so the maximum permissible weight must be restricted to its maximum endurable weight. There are two narrow tunnels, O-Hagi and Wada-Gawa Tunnels. For transporting the water wheel runners, the inlet valve bodies and the inlet valve cylinders, these tunnels must be curved. The road slope is 14.8 % at maximum. The maximum height and width for going through an underpass which crosses the Tateyama Railway Line are both 3,800 mm. Therefore, it is necessary to transport some equipment through this underpass by means of small rollers. The narrowest part of the road is now located at the 3,500-m/m point and extension of the road width along the 300-m length is necessary.

Key:

a: Okada
 c: Matsunoki
 e: Slope 14.8 %
 g: Nakaji Mountain
 i: Yoshimi Bridge
 k: Wada
 m: Oguchigawa Bridge
 o: Shin Nakagi Mt.

b: Okada Tunnel
 d: Matsunoki P.S.
 f: Saikaku Pond
 h: Chigaki
 j: Komi
 l: Snowset
 n: Nakagi Mt.
 p: Oguchi River

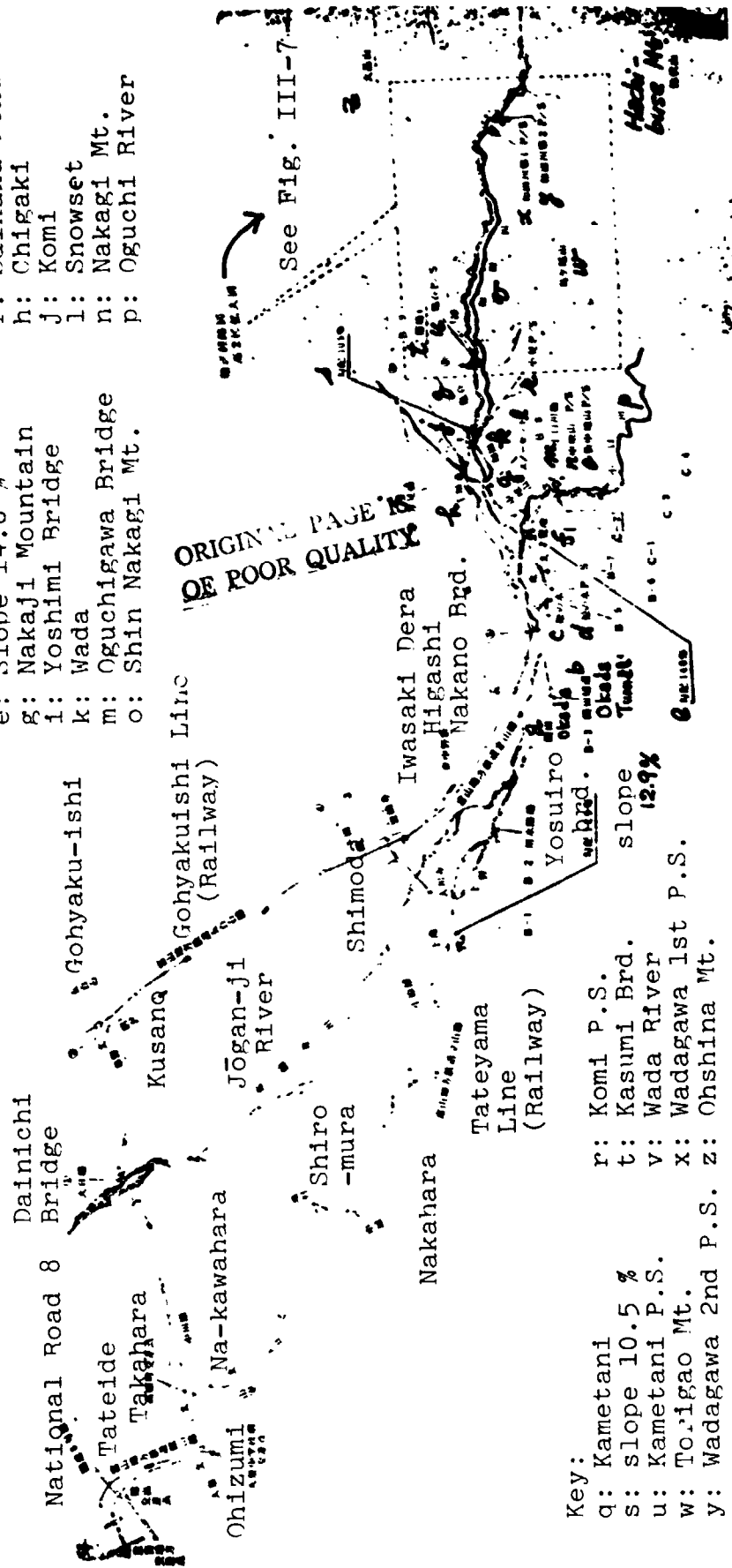

Fig. III-6. Construction Site of A Hydroelectric Power Plant.

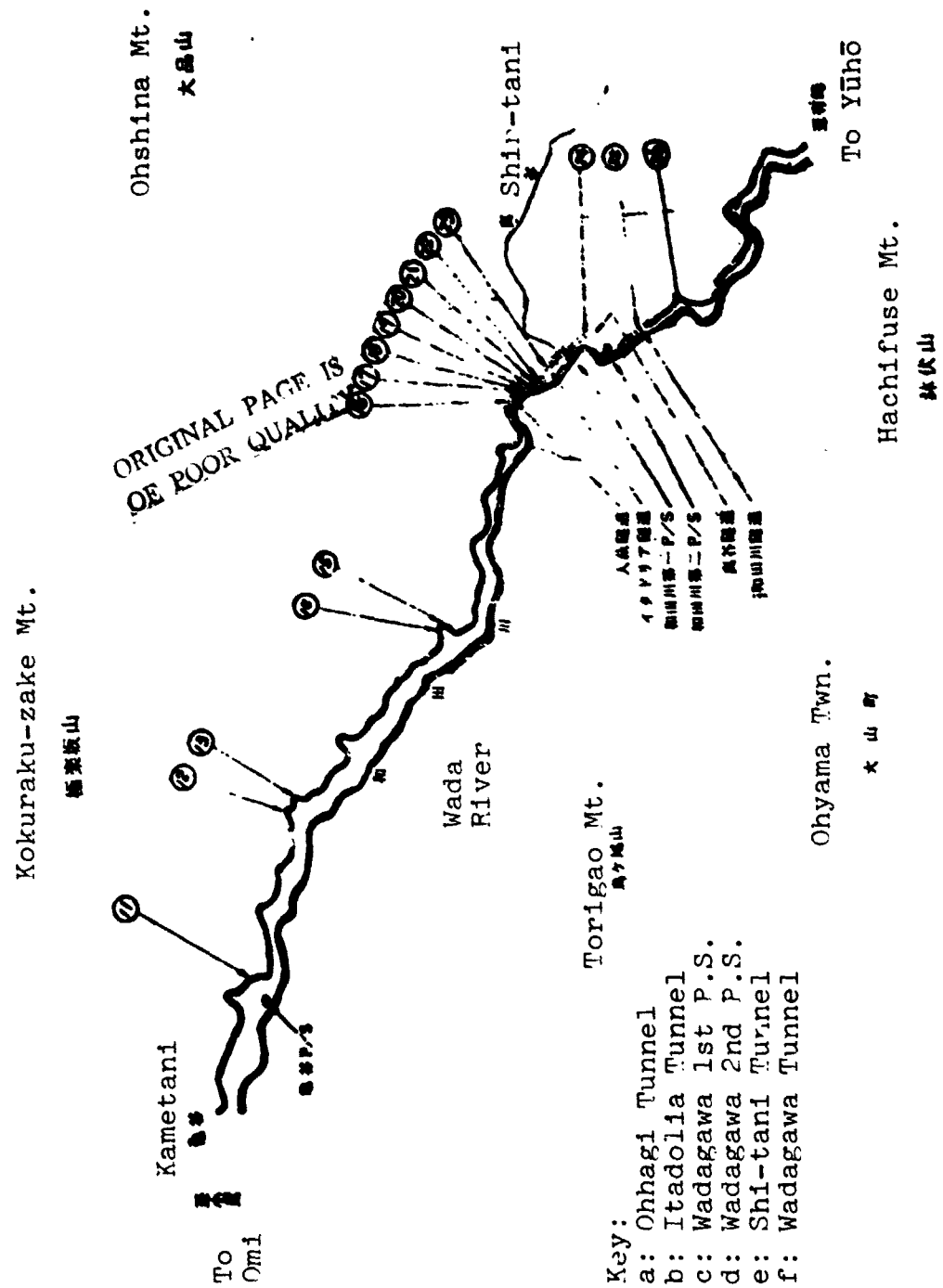

Fig. III-7. Construction Site of A Hydroelectric Power Station.

III-1-3. Transport of Power Generating Equipment for Geothermal Power Stations.

/1

(a) Present State.

K Geothermal Power Plant is located about 28 km north-west of Morioka City and within Hachiman-Daira National Park. Construction equipment for this plant was transported by way of the approximately 10-km route along Tazune River, from Shizuku-ishi Railway Station of the Tazawa-Ko Line to the construction site. (See Fig. III-8) The following points in particular were taken into consideration:

- (1) Since the transportation was to be carried out in a rain and snow season, it was decided that the transportation work by large-size vehicles (trailers) would be concentrated into the days when weather conditions were good.
- (2) For ten bridges on the route from Shizuku-ishi to Amihara, the "over bridge method" was used, in which the bridges were reinforced by additional bridge beams. Temporary bridges, Genmu and Meguri Bridges, were constructed to cross the river.

A 50-thousand-kW turbine generator for geothermal power generation was transported to the construction site. This generator has the largest capacity among generators using geothermal steam. The generator stator was decomposed in the factory into two stator frames (20 tons and 19 tons) and an inner cage (60 tons) due to the transportation restrictions on size and weight. The heaviest material transported to the site was the 60-ton inner cage, and the next heaviest was a 49-ton main transformer. The generator rotor and the turbine rotor, both of which cannot be easily decomposed, were 27 tons and 21 tons, respectively. The heavy materials and their weight are listed below:

	10 to 20 tons	20 to 40 tons	40 to 60 tons	Total Weight
Turbine Equipment	13	4	0	146 tons
Generator Equipment	2	1	1	416
Transformer			1	198
Total	15	5	2	760

(416 tons out of the above 760 tons were transported by trailers of 20 or more tons.)

For the transportation of the heavy materials, the Prefecture Road was widened so that the road width in the straight section was 4.5 m (efficient width: 3.5 m) and every curve radius was greater than 15 m. Since the site is located in a national park and in a hot spring recreational area, the transportation from Abashiri was restricted to night time and every vehicle transporting a heavy cargo was escorted by a guide vehicle. Full priority was given to normal traffic.

The unit transportation cost of trailer transportation was 180 thousand yen per ton. This corresponds to the unit transportation cost of generator stators for large-scale thermal power plants. Except for this cost, the maker bore the heavy material transportation cost of 165 thousand yen per ton, which includes the cost of bridge reinforcement and the cost necessary for the construction site survey to meet government security measures. The total cost spent on heavy material transportation amounted to about 2 % of the total budget for the plant construction.

Fig. III-9 shows 31 sites at which the construction of geothermal power plants by 1985 is planned. The construction sites for geothermal plants are mostly in deep mountainous areas, unlike thermal or nuclear plants. Therefore, the transportation of heavy equipment by inland transportation means is the most serious problem in the development of geothermal power generation. Thus, new transportation means using LTA's are expected to be developed not only for plant equipment but also for construction machinery and materials. According to the interim report by the Demand Survey Division of the Conference of the Electric Power Industry (in September, 1977), if such plans are put into effect, the development of 800 thousand kW by 1985 and 2,500 thousand kW by 1990 is feasible. Therefore, one can anticipate development at a pace of 100 thousand kW per year up until 1985 and 300 thousand kW per year up until 1990.

The geothermal plants which have been already built and the site where the geothermal plant construction has begun are listed below:

Name of Plant	Output	Total Construction Cost	Unit Construction Cost
Mori (Hokkaido Electricity)	50 MW	8,210 million yen	164 thousand yen/kW
Tsugenuma (Tohoku Electricity)	50	7,380	148
Haccho Daira (Kyūshū Electricity)	50	11,500	230
Onikubi (Agency for Electric Power Development)	25	4,130	165
Total	175	31,220	178 (Average)

The estimated total construction cost up until 1985 is 142.4 billion yen, and up until 1990, 445.0 billion yen.

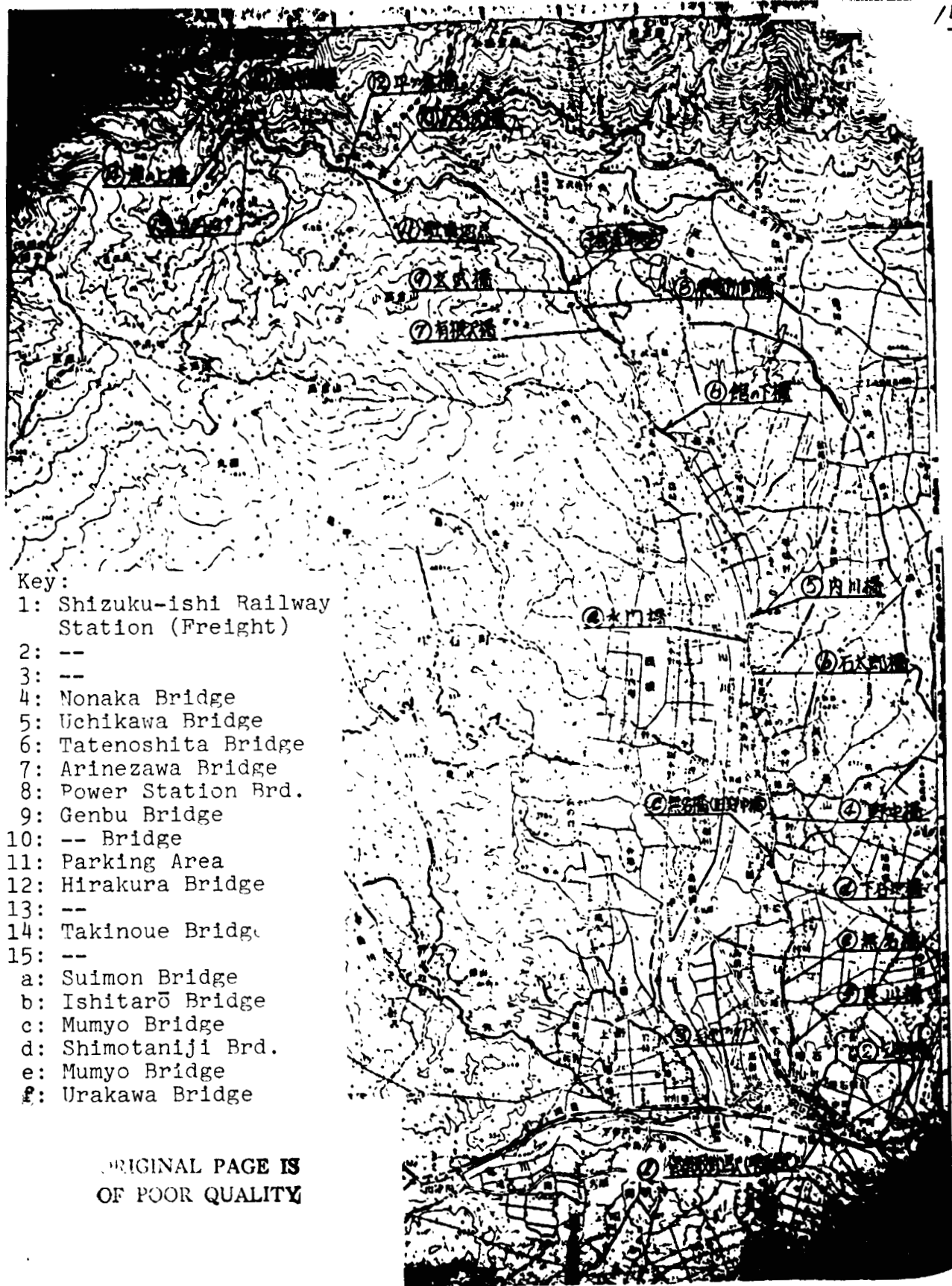

Fig. III-8. Construction Site of K Geothermal Power Plant.

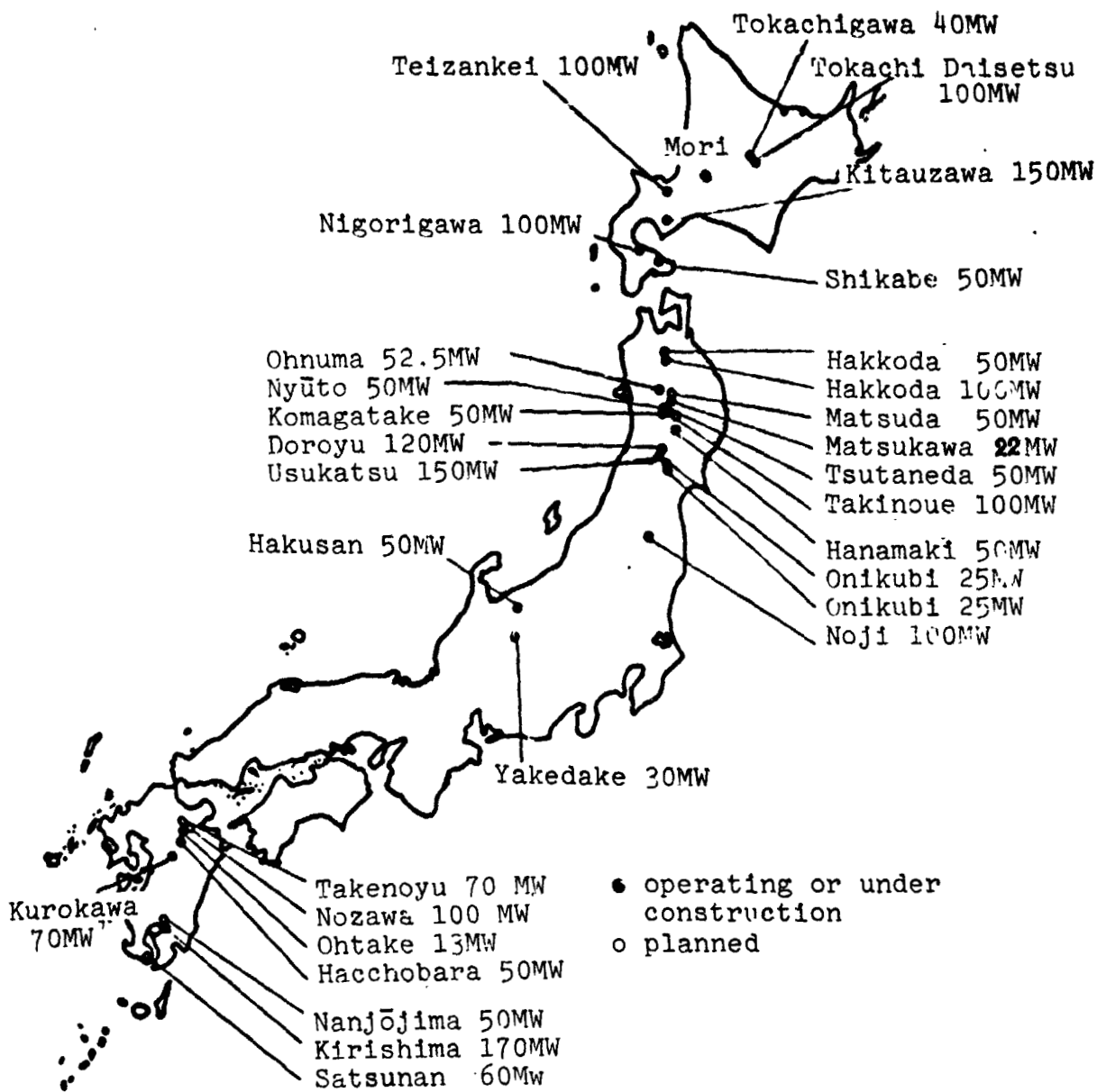

Fig. III-9. Candidates for Construction Sites of Geothermal Power Plants.

- Being Planned for the Period until 1985 -

31 Sites Including 4 Sites Where the Plants Are in Operation or Under Construction.

(b) Increase in Equipment Capacity for Geothermal Power Stations.

/50

The 50-thousand-kW geothermal generator is the biggest one in Japan. However, in the past, a 110-thousand-kW equipment was planned by Kaiser Company, U.S.A., and was exported by a Japanese maker (Toshiba Electric). A 150-thousand-kW class turbine rotor material has already been developed. Furthermore, according to recent information, a geothermal power generation of 500 to 3,000 thousand kW is now thought to be possible by using 2,000 m to 4,000 m boring depth. The Kaiser Company, U.S.A., which has a 500-thousand-kW plant, has undertaken a project to extend the output to 2,500 thousand kW. (See Table III-5) Development of 250 thousand-kW class plants is presently a goal in Japan. However, the 50 thousand-kW equipment will be replaced by 110 thousand-kW class equipment in the near future. At that time, the weight of a generator stator frame will be 30 tons, 50% heavier. The decomposition of the stator frames and the weight of the decomposed pieces will create a serious problem together with the weight of other equipment such as transformers. The desire for a new means of transportation using LTA's is thus constantly growing. Success in developing a 250-thousand-kW class equipment unit can be said to depend on the fulfillment of this task.

The anticipated amount of heavy material transportation annually is 900 tons up until 1985 and 2,000 tons up until 1990. This estimate was made in accordance with the plan of development reported by the Conference of Electric Power Industry.

Table III-5. Geothermal Power Generation
In the World

*In Partial Operation

Country	District	Output (MW) In Operation	Under Construction or Planned (MW)
Italy	Larderello	380.6	
	Monte Amiata	22.0	
	Others	15.0	
	Total	417.6	
Japan	Matsukawa	22.0	Katsuneda 50.0
	Ch-Take	11.0(7.5)*	Haccho-Bara 50.0
	Oh-Numa	10.0(12.5)*	Mori 50.0
	Onikubi	25.0	
	Total	68.0	150.0
New Zealand	Wairakei	192.6	Broadlander 200.0
	Karewau	10.0	Waiotapu 564.0
	Total	202.6	764.0
Mexico	Balla	82.0	Mexicali 295.0
	Cerro Brieto	75.0	
	Total	157.0	
U.S.A.	Kaiser	522.6	Kaiser 406.0
			Imperial Valley 65.0
	Total	522.6	Battle Mountain 10.0 481.0
Iceland	Namahafull	3.0	Namahafull 3.0
	Henkir	17.0	Kurafura 60.0
	Total	20.0	63.0
France			Guadeloupe (West Indies) 30.0
Nairobi			Nairobi 15.0
U.S.S.R.	Baujyek	5.0	Baujyek 95.0
	Baratsunka	0.7	Kunashiri 6.0
	Total	5.7	Abachinskaya 30.0 131.0
Taiwan			Matou 10.
India			Li 50.0
Indonesia			Kamoyan 30.0
	Total		Deyen 5.0 35.0
(Continued)			

Philippines			Teiui	220.0
			Los Bafios	220.0
			Total	440.0
Nicaragua			Momotombo and others	175.0
El Salvador	Kahuachapán	60.0	Ahuachapán	60.0
Chile			El Tatio	20.0
Grand Total		1453.5		2719.0

The data are those of June, 1976.
 Surveyed by:

Division of Thermal Power,
 Department of Public Utilities,
 Agency of Resource and Energy,
 Ministry of International Trade and
 Industry.

Remark: Besides the countries listed above, the following countries are being presently surveyed: Greece, Ethiopia, Algeria, Yugoslavia, China, Peru, Guatemala, Costa Rica, Colombia and other countries.

Translator's Note:

Certain obscure plane names had to merely be transliterated from their Japanese pronounciations, and thus seem in their English spelling may have resulted.

III-1-4. Transport Problems in Construction of Power Transmission Line. /52

(This section is based on the interview with Mr. Masato Yamamoto, section director, Tokyo Electricity.)

In the transportation of construction equipment, trucks are used in flat areas, while helicopters and overhead freight-carrying cables are used in mountainous areas. In the latter case, the use of overhead freight-carrying cables is in general more economical.

As an example of power transmission lines, Shin-Chichibu/Tichigi Line is described as follows: This 6-conductor line stretches 120 km from Chichibu City through Saitama Sanri-Mura, Ohta City, Ashikaga City, Kiryu City, Kanuma and Ugi'ie City of Tshigi Prefecture up to Utsunomiya City. This line is a typical large-capacity modern power transmission line which transmits the power of 10,000 thousand kW per route at 500 kV. The conductors are heat-resistant hard-core aluminum wires. 247 steel towers were constructed at 400 to 500-m intervals. These towers are an average of 80 m high and the total weight of the towers is 31,000 tons. The average weight of one tower is 113 tons and the average cost is about 200 million yen per tower. The construction period was three years, from October, 1975 to November, 1976. The total weight of the equipment which was transported for construction was 216,000 tons. It was transported by:

Helicopters	36 (17 %)	1,800 (67 %)	49,000 yen/ton
Overhead Freight-Carrying Cables	102 (47 %)	600 (22 %)	1,700 to 4,000 yen/ton
Trucks	78 (36 %)	300 (11 %)	4,000 yen/ton
	thousand tons	million yen	

In general, more than 17 % of the total transportation for power transmission line construction is done by helicopters, and in some cases, as much as 30 to 40 %. Recently, for environment conservation reasons, the use of overhead freight-carrying cables is decreasing.

MAIN POWER TRANSMISSION LINES

ORIGINAL PAGE IS
OF POOR QUALITY.

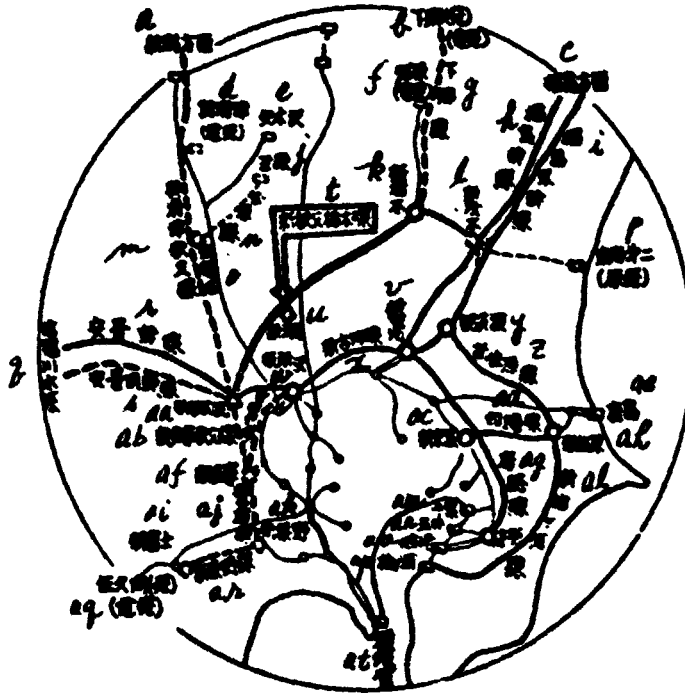

Remarks:

- 500 thousand V
- 275 thousand V

Fig. III-10. Shi-Tochigi Line.

Key:

- | | | |
|--------------------------------|-----------------------------|------------------------------------|
| a: to Niigata | b: Shimogō (Power P.) | c: Fukushima |
| d: Okukiyotsu | e: Yagisawa | f: Num: a |
| g: Shimogō Line | h: Fukushima Main Line | |
| i: Fukushima Higashi Main Line | j: Tamabara | |
| k: Shin-Tochigi | l: Shin-Mogi | m: Oku-Kiyotsu/Chichibu Line |
| n: Tamabara Line | o: Shin-Kuwana | p: Tohkai 2nd (Nuclear P.) |
| q: to Shinana R. | r: Anryo Main Line | t: <u>Shin-Chichibu/Tochigi L.</u> |
| u: Shin-Okabe | v: Shin-Furukawa | w: Shin-Tokorozawa |
| x: Shin-Furukawa L. | y: Shin-Tsukuba | z: Shin-Sahara Line |
| aa: Shin-Chichibu | ab: Shin-Tama/Chichibu Line | |
| ac: Shin-Keiyo | ad: Inba Line | ae: Kashima |
| af: Shin-Tama | ag: Bōsō Line | ah: Shin-Sahara |
| ai: Shin-Fuji | aj: Shin-Tama Line | ak: Shin-Hatano |
| al: Shin-Sodegawara | am: Chiba | an: Goi |
| ao: Anegasaki | ap: Sodegaura | aq: Sakuma (Power P.) |
| ar: Shin-Hatano L. | at: Yokosuka | |

(a) Foundation Work.

The soil must be dug for the concrete foundations of the four legs of each steel tower. 5 to 6-ton excavators for this job were disassembled and transported by helicopters. The helicopter which was used has a 2 to 3-ton freight capacity. The concrete foot portions of the four tower legs are about 1,000 tons in weight. The load of 0.9-ton soft cement + 0.1-ton bucket = 1.0-ton load was transported by one helicopter flight. On the average, the flight distance was 25 km or less and the flight time was 4 minutes. Usually, 60 tons of soft cement was placed by four-hours of work. A truck carried 15 tons of soft cement at a time. The currently used transportation is affected by the weather. The average period for completing a 1000 ton cement placement is about one month. The removal of the dug soil was also performed by helicopters. The approximate size of the tower feet is shown in the figure below. The tower feet placed on a mountain slope must be designed to resist the falling-down moment.

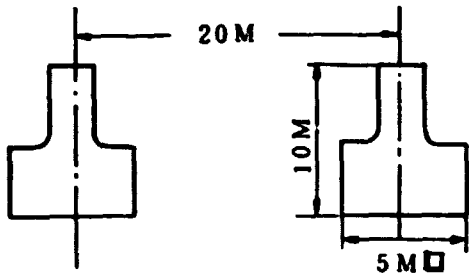

(b) Assembling Work.

600 to 800 ϕ , 4-ton/meter steel materials were decomposed and transported by helicopter to the construction sites. If the steel materials are made in a panel or block form and assembled at the sites, the high-place work for assembling at the sites could be largely reduced and the construction cost would be lowered by the greater efficiency. The height of the steel towers is 80 m in average, although some of them are 100 to 120 m high.

The assembling work is done by using on-the-ground pushing-up cranes.

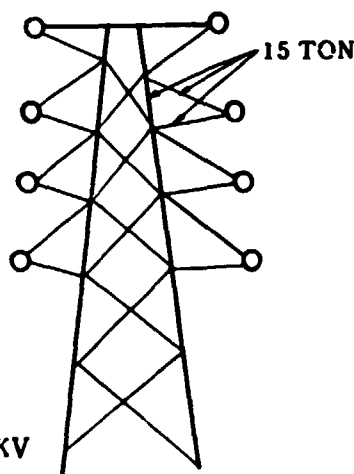

100-200 ton Steel Tower

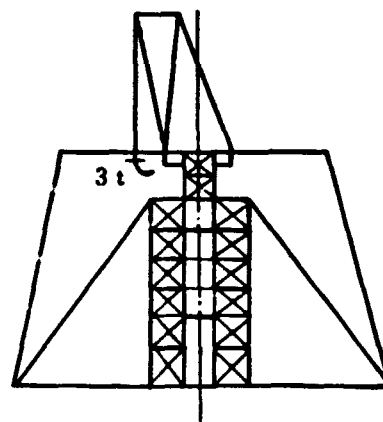

On-the-Ground Pushing-Up Crane

If the new transportation means using LTA's are developed and can /54 transport heavy materials with 50 to 70-ton weight, transportation of assembled towers might be possible for 275-kV transmission lines. Of course, even in that case, the panel or block decomposition method would also be used. Furthermore, if the above-mentioned cranes can be replaced by LTA's which are capable of crane work, the assembling work of the cranes at the construction sites can be eliminated. In mountainous areas, it is difficult to obtain sufficient space to assemble the members. The necessary amount of space for this task is 2,000 to 4,000 m², and 5,000 m² is desirable if possible. The panel or block decomposition method is now desired for this reason, too.

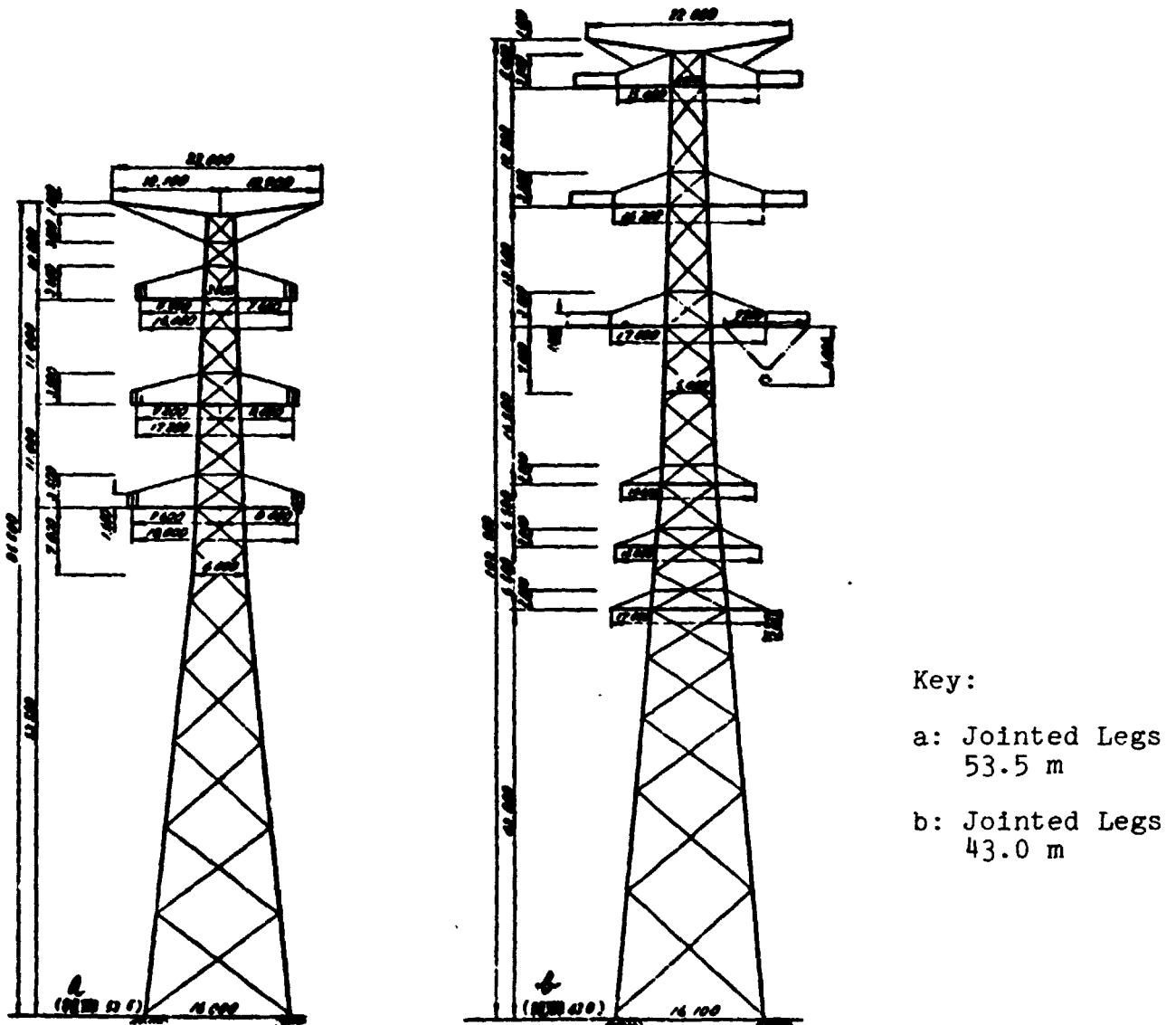
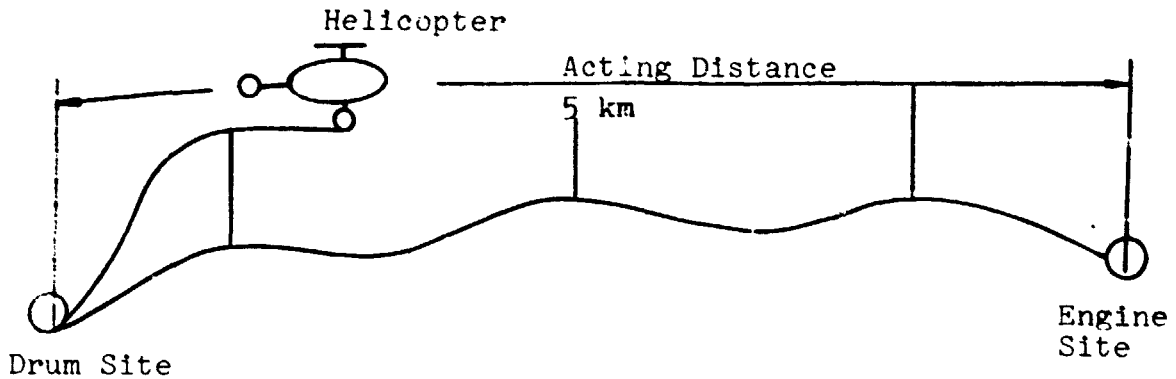

Fig. III-11. Power Transmission Line Steel Towers.

(c) Wiring Work.

One unit of the drums used in construction is 5 tons in weight. The drums are placed at the roadside drum sites. The engines used for wiring are 23 tons in weight and are transported by helicopters to the construction sites.



/55

The messenger wire (14 Ø) is drawn by a helicopter. Then this messenger wire is replaced by a 16 to 24-Ø wire. The final main wire is 38.4 Ø.

The power carrying wires consists of six sextupled conductors (6 x 6 = 36) and two other conductors. In total, they are 38-tupled. The helicopters used in the wiring work go from the drum site to the engine site (about 5 km far) and back in four minutes and repeat this flight in four hours.

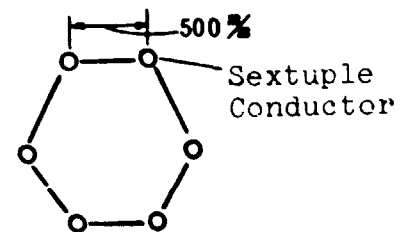

(d) Summary of Transportation for Construction of Power Transmission Lines.

(i) Classified Transportation by Helicopter.
(Average Transportation per One Unit of Helicopter)

Soft Cement	1,300 tons (80 %)
Steel Tower Members	240 tons (14 %)
Tools	100 tons (6 %)
Total	1,640 tons

(i') Estimated Total Transportation by Helicopters for Power Transmission Line Construction.

According to a middle-term plan (terminating in 1981) of Tokyo Electricity, the annual transportation will be 80,000 to 100,000 tons. A part of the construction plan is shown in Table III-6.

(iii) State of Utilization Concerning Power Transmission Lines.

In Japan, there are 28 helicopters which can carry a load over one ton: fourteen Bell 204-14's, two Bell 214B's and three Vertol KB 1047's.

At a place within 30 m from each steel tower, a 150 to 300-m² ground is selected for collecting the materials which are dropped from the helicopters.

The heliport base is located at 2.5-km place.

The operating time of a helicopter is calculated to be about 500 hours per year which is equal to :

$$365 \text{ days} \times (1/1.7) = 215 \text{ days per year.}$$

The basic rent of a helicopter is 380 thousand yen per hour for 0.8 to 1.5-ton load Bell 204B. /56

	Payload (ton)	Rent (Thousand Yen/Hour)	Available Units
Bell 204B	0.8 to 1.2	370	14
Bell 214B	2.5 to 3.2	670	2
Vertol KV 107	2.5	630	3
			9
		Total:	28

Table III-6. Plans of Power Transmission Line Construction in 1977.

Company	1977		1978	
Hokkaido	150 km	37.0 Billion Yen	266 km	26.6 Billion Yen
Tōhoku	383	62.1	420	90.1
Tokyo	684	283.9	163	234.5
Chūbu	171	30.4	456	141.7
Hokuriku	126	25.0	45	5.7
Kansai	97	91.7	82	47.3
Chūgoku	186	22.1	41	9.7
Shikoku	108	3.5	171	16.2
Kyūshū	488	89.3	121	29.9
Electric Power Development	216	64.6	26	10.6
Total	2,609 km	759.6 Billion Yen	1,796 km	612.3 Billion Yen

Steel Towers: 35,000 tons/year
Total Amount: 250,000 tons/year

Cf. Refer to the table at the end of Section III-2 for the current fare of helicopters.

(iv) An Effect of New Transportation Means Using LTA's.

The transportation of construction workers to construction sites is a serious problem. 100 to 150 persons must be transported for one project. If the weight of a person is calculated to be 100 kg, including tools and small equipment, the amount which must be transported is 100 kg x 150 persons = 15 tons. If this transportation can be done safely by new transportation means using LTA's, the working efficiency of the construction sites will be improved. /57

(v) Interview with Mr. Teruyuki Kōno, Asahi Helicopter Company, Concerning LTA Transportation.

A 500-kV steel tower is about 100 tons in weight. A new transportation system is likely to be possible, in which this tower is decomposed into three parts and each part transported by an LTA.

With regard to the soft cement placement of about 3000 m³ (700 tons) per one tower (about 180 tons per one foot), about 10-ton a unit transportation will be considered for future air transportation. (Cf. The unit transportation of soft cement by trucks is now about 2.3 tons x 6 = 15 tons.)

At present, the unit transportation of 6 to 7 tons of soft cement by Sikorsky 64 is under consideration.

If the unit transportation of a 10-ton order becomes possible, transportation efficiency would be improved by about four times. The current problem is the decrease of transportation efficiency due to the difficulty in locating helicopters within the 2.5 km distance.

The optimal timing of soft cement placement is two hours after it is mixed. Is it desirable that a new transportation system fulfill this requirement.

(vi) Fractions of Construction Cost of Power Transmission Line.

The approximate fractions of transmission line construction at present is as follows:

Material (Equipment) Cost	40 %,
Land Use Cost	20 to 30 % , and
Construction Work Cost	20 to 30 %.

About 5 % of the above construction work cost is transportation cost.

The soft cement transportation cost is about 28 to 40 thousand yen per ton and its transportation distance is 2.5 km at present.

III-1-5. Transport for Construction of Power Substation.

Construction of a power plant is always followed by construction of substations and transmission means which are means of distributing the electric power. One field in which a new transportation system such as an LTA system is desired is inland transportation for construction of power substations and power plants. Transformers for sea-side thermal or nuclear plants are transported by coastal marine transportation and by in-yard special transportation means. In this transportation, 600 to 800-ton transformers are transported in their integrated forms. The transportation of transformers to an inland station is carried out by running a specially made freight car to the railway station nearest the construction site. The limitation on the size of such a car on the railway is 3,100-mm width x 4,100-mm height x 12,500-mm length. Within these limits, a transformer up to 240 tons may be transported by rail. (The capacity in Japan is much less than that in other countries. For example, it is said that 420-ton railway transportation is possible in Western Europe and 600-ton is possible in the U.S.A.) If the construction site is at an isolated location and if there are many small bridges or many narrow road sections between the railway station and the construction site, the transformer must be decomposed into 6 to 9 parts, in order to satisfy transportation conditions, similarly to the equipment for pumped-storage or common hydroelectric plants. If a 100-ton class transformer is transported under very poor transportation conditions, additional costs such as bridge reinforcement cost, road enlargement cost and compensation cost, may become extremely high, and thus, the unit transportation cost may exceed 500 thousand yen per ton in some cases. Cases in which the unit transportation cost is about 250 thousand yen per ton are not extraordinary. Such a unit transportation cost is 3 to 4 times higher /58 than that of transportation to pumped-storage plants. Therefore, in some cases, the transportation cost, including the road-condition dependent additional cost, amounts to 20 % of the product price. In such a case, even though decomposition of the equipment causes a 10 to 15 % increase of the product price, it is more economical to opt for reducing the road-condition related additional cost by decomposing the equipment. This means that the additional transportation cost must be taken into account when the product is designed.

(a) Significance of Transportation Problems Resulting from the Rationalization Plan of the Japanese National Railways.

According to the rationalization plan of the Japan National Railways, about one third of all freight train stations will be closed and old large-size freight cars will be successively phased out. (Cars which are older than their estimated lifetime are going to be phased out. In the first stage, this amounts to 550 50 ton-load Siki cars.) This plan results in a restriction not only on transformer transportation but also on heavy freight transportation in general. Consequently, the specially added transportation cost will increase, creating a serious problem related to the increase in heavy freight transportation. At the same time, spontaneous selection of the transportation period becomes more difficult.

(b) Transportation of Transformers for Substations.

About 100 power substations per year are planned for construction in 1977 and 1978. These are shown in Table III-7. Transportation in 1977 and 1978 is as follows:

Less Than 100 MVA: $(47+33) \times 30$ tons = 2,400 tons (average)
 More Than 100 MVA: $(94+107) \times 160$ tons = 32,160 tons (average)

Total: 34,560 tons.

Table III-7. Construction Plans of Power Substations in 1977 and 1978.

	Lower Than 100 MVA	Higher Than 100 MVA
Hokkaido Electricity	4	
	1	5
Tōhoku Electricity	4	8
	2	6
Tokyo Electricity	15	31
	7	43
Chūbu Electricity	1	9
	1	16
Hokuriku Electricity		2
		1
Kansai Electricity		14
		25
Chūgoku Electricity	18	7
	16	5
Shikoku Electricity	2	1
	1	3
Kyushu Electricity	3	22
	5	3
Total: 1977	47	94
1978	33	107
Average Weight	30 tons	160 tons

The main substation construction plans which will begin to be carried out in 1977 and 1978 are listed in Table III-8. The total budget (for a two-year plan) is 696,245 million yen. There are 76 construction sites for substations with a capacity larger than 220 kV and 250 MVA, and the budget planned for them is 384,004 million yen in total. These large-scale substations are assumed to require heavy equipment transportation. Assuming that 13 % of the total cost amounts to 50.7 billion yen if a new transportation system such as an LTA system can reduce this cost by 5 % by reducing the cost increase due to the decomposition of equipment or by reducing the road-related specially-added cost, the savings would be amount to as much as 2.5 billion yen.

Table III-8. Construction Plans of Power
Substation - Construction Begins in 1977 or 1978.

Company	Annual Budget	Heavy Weight Equipment	
		Sites	Budget (200KV-250MVA or higher)
Hokkaido Electricity	2,508 9,306		
Tōhoku Electricity	14,860 12,252	4	6,870
Tokyo Electricity	717 122,816 157,504	29	186,258
Chūbu Electricity	28,481 69,926	10	54,429
Hokuriku Electricity	3,276 5,786	1	3,090
Kansai Electricity	12,462 50,169 68,313	15	51,370
Chūgoku Electricity	29,148 10,574	5	21,486
Shikoku Electricity	987 2,107 8,406		
Kyūshū Electricity	69,504 15,630	12	63,501
Okinawa Electricity	732 781		
Total:	696,245 million yen	76	386,004 million yen

Refer to Figs. III-12 to III-19 for the locations of planned substation construction scheduled in 1977 and 1978.

Keys In Fig. III-12.

A: Power Station	B: Power Transmission Line
	500KV Operation/500KV Designed
	500KV Step-Up /275KV Newly Constructed
C: Substation	D: Switching Station
500KV/500KV Expanded	
275KV/275KV Expanded	
E: Construction Begun	

a: Kashiwazaki	b: Togogura	c: Ohmi
d: Oku-Tadami	e: Ohtsu-Mata	f: Shinanogari
g: Yagisawa	h: Shimogō (Power P.)	i: Numabara (power p.)
j: Shin-Fukushima	k: Fukushima 1st S.	l: Fukushima 2nd St.
m: Hirono St.	n: Shin-Iwaki	o: Fukushima Main L.
p: Fukushima West M.L.	q: Oku-Kiyotsu	r: Tamabara
s: Imaichi	t: Shin-Tochigi	u: Shin-Niigata M.L.
v: Cho-Tokyo M.L.	w: Shin-Tochigi/Tama M.L.	x: Shin-Toshigi
y: Tohkai 2nd (Nuclear Plant)		z: Ohmachi
aa: Nakanosawa	ab: Shin-Takasegawa	ac: Azumi
ad: Azumi Main Line	ae: Azumi South M.L.	af: Shin-Chichibu
ag: Shin-Tabe	ah: Shin-Furukawa Line	ai: Shin-Furukawa
aj: Shin-Tsukuba	ak: Shin-Sahara Line	al: Kashima (Thermal P.P)
am: Kashima	an: Oh-Shima	ao: Toshi-Jima
ap: Nii-Jima	aq: Shikine-Jima	ar: Miyake-Jima
as: Mikura-Jima	at: Hachijō-Jima	au: Aogo-Shima
av: Ogasawara-Chichi-Jima	aw: Ogasawara-Haha-Jima	
ba: Sakuma East M.L.	bb: Shin-Sodegawara L.	bc: Bosc Line

ORIGINAL
OF POOR QUALITY

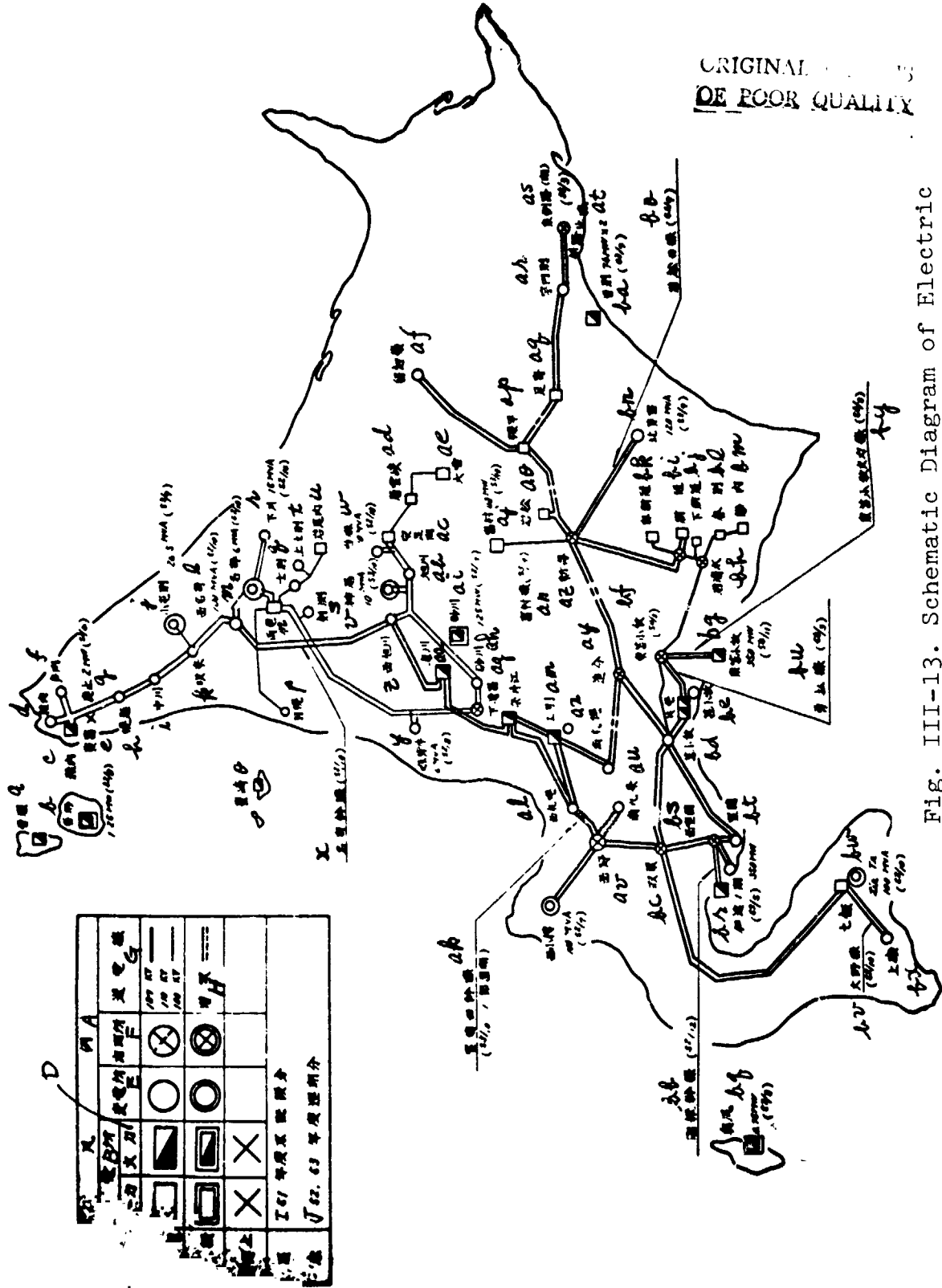

Fig. III-13. Schematic Diagram of Electric Transmission Lines in Hokkaido. (Operation Starts 1977 and 1978.)

凡	例 A		发电機
	電	送電線	
○	○	○	100 MW
□	□	□	100 MW
△	△	△	100 MW
×	×	×	100 MW
◇	◇	◇	100 MW
▽	▽	▽	100 MW
◇	◇	◇	100 MW
▽	▽	▽	100 MW
◇	◇	◇	100 MW
▽	▽	▽	100 MW

I 67 年度完成額分
I 68. 69 年度完成額分

Keys to Fig. III-13.

A: Keys	B: Power Plant	C: Hydroelectric
D: Thermal	E: Substation	F: Switching Station
G: Power Transmission Line		
a: Roshin	b: Tokei	c: Wakkanai
d: Wakkanai	e: Tohfu	f: Ashima
g: Haishi	h: Horonobe	i: Nakagawa
j: Kotonbetsu	k: Sakirai	l: Nishi-Nayoro
m: Nayoro	n: Amaryu	o: Toyosaki
p: Haboro	q: Shibetsu	r: Kami-Shibetsu
s: Kenbuchi	t: Kami-Shibetsu	u: Iwao-Nai
v: Kamui	w: Tohma	x: Nayoro Main Line
y: Imosegyu	z: Nishi-Asahikawa	
aa: Takikawa	ab: Asahikawa	ac: Ashima
ad: Sōunkyō	ae: Daisetsu	af: Rubena
ag: Shimo-Kehfu	ah: Sunakawa	ai: Sunakawa
aj: Tomimura	ak: Muroran West M.L.	al: Nishi-Sapporo
am: Ebetsu	an: Tomimura Line	ao: Iwamatsu
ap: Yonedaira	aq: Ashiyori	ar: Uenbetsu
as: Higashi-Kushiro	at: Onbetsu	au: Nishi-Otaru
av: Nishino	aw: Minami-Kujō	ax: Minami-Sapporo
ay: Oiwake	az: Niitoku	
ba: Onbetsu	bb: Tannr Main Line	bc: Futaba
bd: Tomakomai	be: Tomakomai	bf: Higashi-Tomakomai
bg: Higashi-Tomakomai	bh: Iwashimizu	bi: Niikappu
bj: Shimo-Niikappu	bk: Oku-Niikappu	bl: Harubetsu
bm: Shizunai	bn: Kita-Memuro	bo: Iwamatsu East L.
bq: Okujiri	br: Idachi	bs: Nishi-Muroran
bt: Muroran	bu: Yubutsu	bv: Ohno Line
bw: Shichihan	bx: Kamiryo	by: Higashi-Tomakomai Thermal Plant Line

(1978年度末)

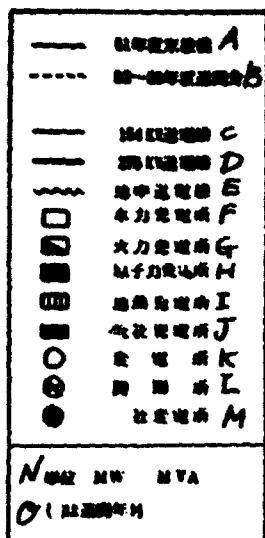

ORIGINAL PAGE IS OF POOR QUALITY

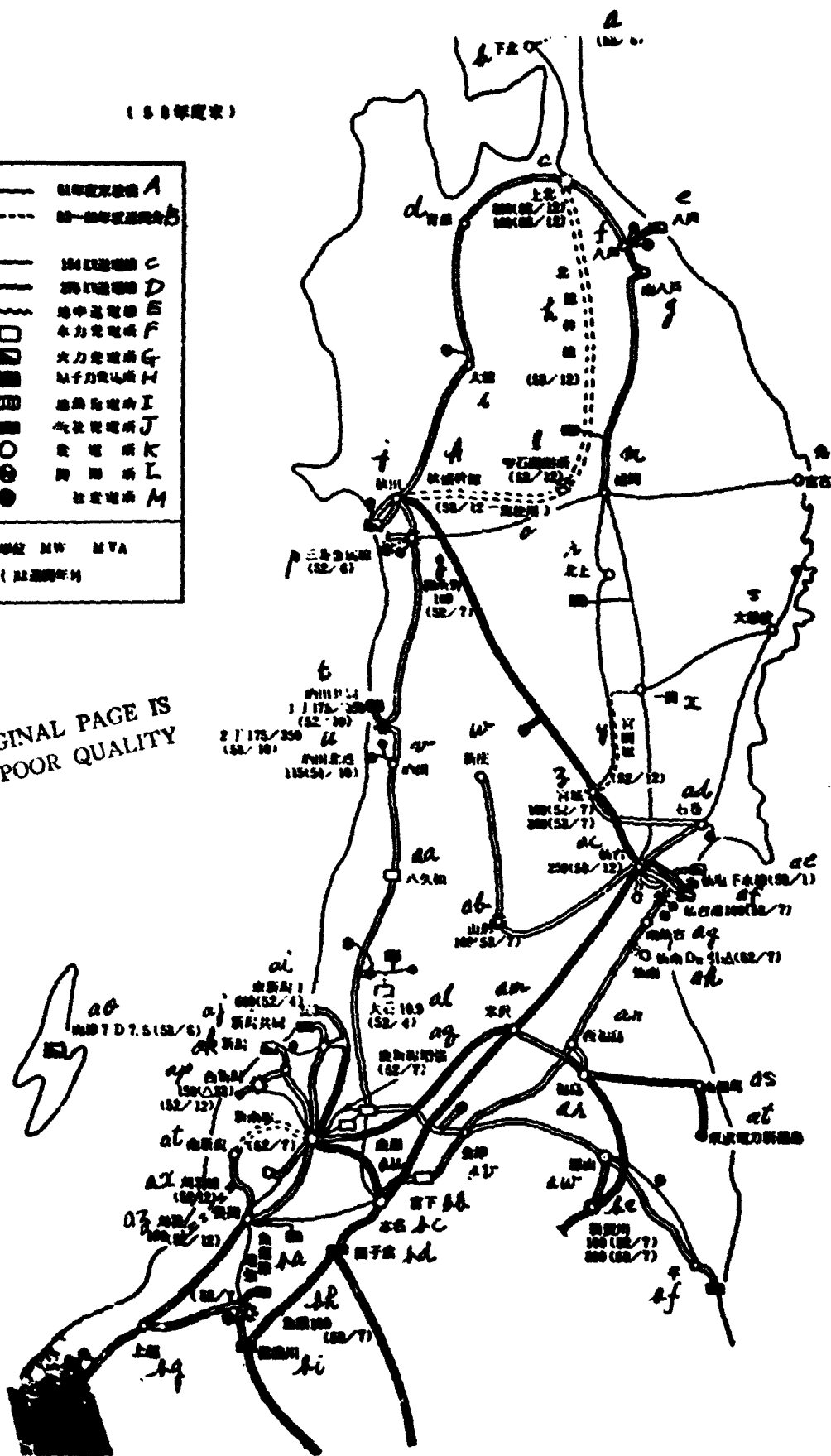

Fig. III-14. Power Transmission Lines of Tohoku District. (In the State at the End of 1978 Fiscal Year)

Keys to Fig. III-14.

A: Not Finished by 1976	B: Operation Starts 1977 - 1978
C: 154 KV Transmission Line	D: 275 KV Transmission Line
E: Underground Line	F: Hydroelectric Plant
G: Thermal Plant	H: Nuclear Plant
I: Geothermal Plant	J: Power Plant of Other Company
K: Substation	L: Switching Station
M: Substation of Other Company	N: Unit
O: The numbers in parentheses indicate the time when the operation will start or started.	

a: Kaihatsu Cement L.	b: Shimokita	c: Kamikita
d: Aomori	e: Hachinohe	f: Hachinohe
g: Minami-Hachinohe	h: Hokubu Main Line	i: Ohdate
j: Akita	k: Aki-Mori Main Line	l: Shizukuishi S.S.
m: Morioka	n: Miyako	o: Partially Completed
p: Mitsubishi Metal L.	q: Goshono	r: Kitagami
s: Ohfunawatari	t: Sakata Kyōdō	u: Sakata Hokkō
v: Sakata	w: Shinjō	x: Ichinoseki
y: Miyazeki Line	z: Miyagi	

aa: Hakuwa	ab: Yamagata	ac: Sendai
ad: Ishinomaki	ae: Sen-En Under-Water L	af: Sendai Harbor
ag: Minami-Sendai	ah: Sennan	ai: Higashi-Niigata
aj: Niigata-Kyōdō	ak: Niigata	al: Ohishi
am: Yonezawa	an: Nishi-Fukushima	ao: Ryotsu
aq: Shin L. (Expanded)	ar: Fukushima	as: Minami-Sōma
at: Tokyo Electricity Shin-Fukushima Station		au: Kase
av: Aizu	aw: Kooriyama	ax: Kariba Line
ay: Nagaoka	az: Kariba	ap: Nishi-Niigata

ba: Uwonuma L. (Expanded)	bb: Miyashita	bc: Honna
bd: Tagokura	be: Suga-Gawa	bf: Taira
bg: Jōetsu	bh: Uwonuma	bi: Shinano-Gawa

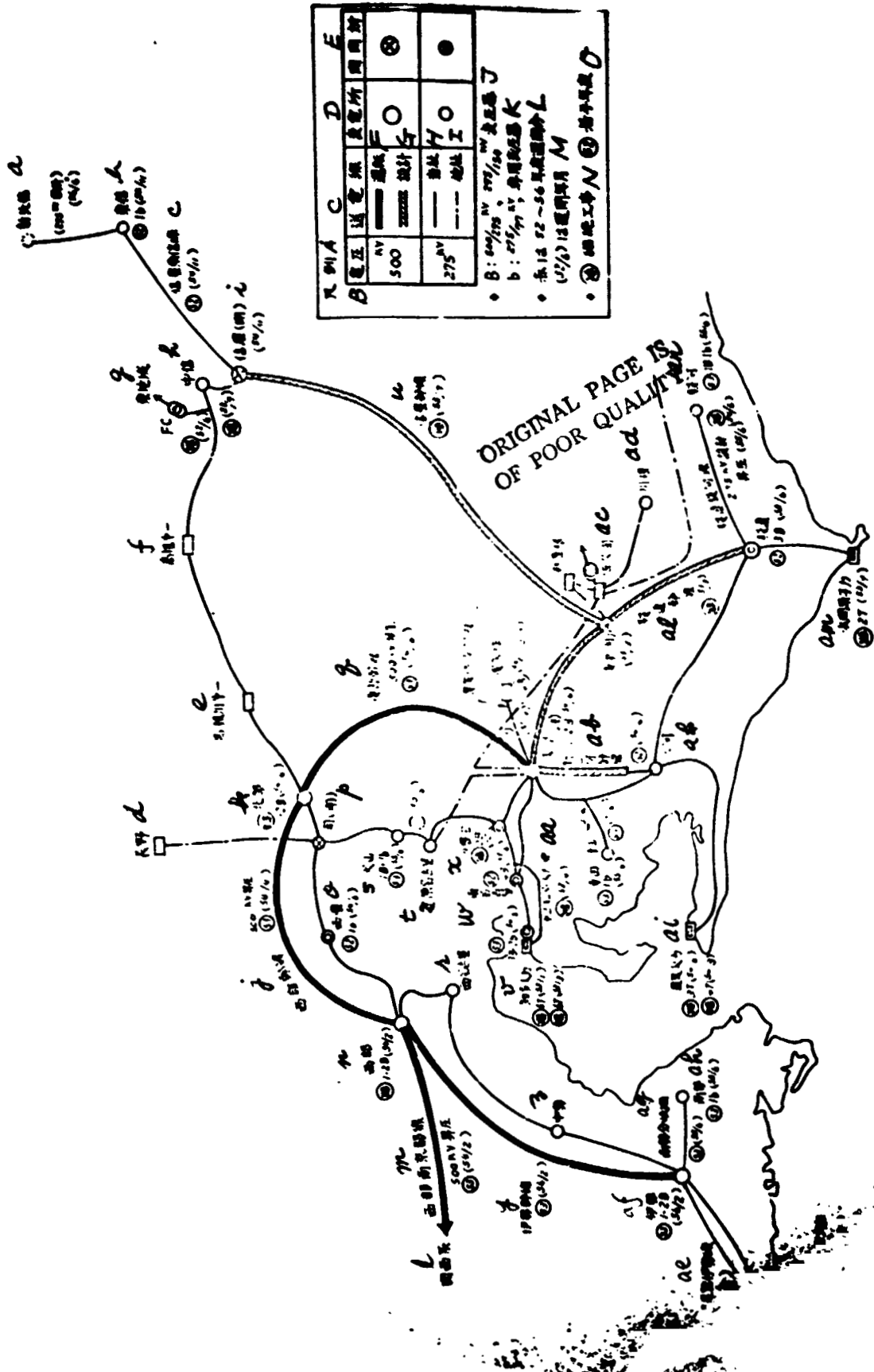

Fig. III-15. Power Transmission Lines in Chubu District at the End of 1981 Fiscal Year

Keys to Fig. III-15.

A: Keys	B: Voltage	C: Transmission Line
D: Substation	E: Switching Station	F: In Operation
G: Planned	H: Our Company	I: Others
J: Transformer	K: Special Transformer	L: Operation Starts in 1977 to 1981
M: Operation Starting	N: Construction Continued	
O: Construction Starting Date		

a: Shin-Hokushin	b: Toshin	c: Shinano East L.
d: Nagano	e: Mase-Gawa 1st	f: Takane 1st
g: Eastern Area	h: Chu-Shin	j: West Main Line
k: Northern District	l: Kansai District	m: Seibu-Minami-Kyōto L.
n: Seibu	o: Sei-Nō	p: Seki
q: East Main Line	r: Nishi-Nagoya	s: Inuyama
t: Dengen-Nagoya	u: Shin-Nō Main Line	v: Chita Thermal P.
w: Higashi-Nagoya	x: Kita-Toyota	y: Ise Main Line
z: Nakase	i: Shinano Switching S.	

aa: 2nd Chita T.P.Line	ab: Shin-Mikawa Line	ac: Sakuma
ad: Kawane	ae: 2nd Owase-Ise Line	af: Ise
ag: Sansei Branching L.	ah: Sansei	ai: Atsumi Thermal P.
aj: Kohda	ak: Mikawa	al: Sun-En Main L.
am: Hamaoka Nuclear Plant		

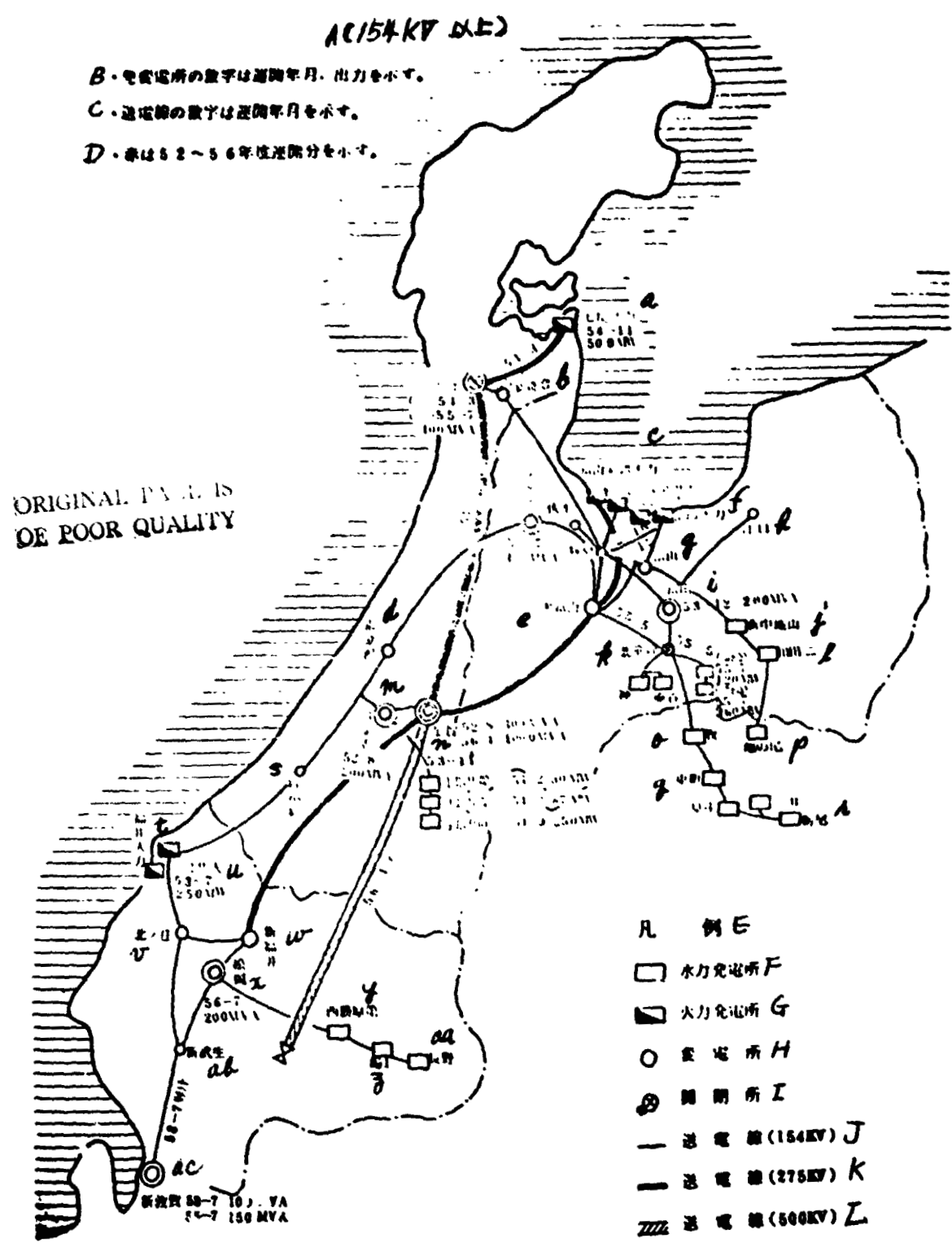

Fig. III-16. Construction Plans of Power Plants and Transmission Lines. (Higher Than 154 kV)

Keys to Fig. III-16.

- A: (Higher Than 154 KV) B: The numbers attached to each power **station** or substation denote the date when the operation started or will start.
- C: The number attached to each transmission line denotes the date when the operation started. D: The one marked by the red denotes that its operation will start in 1977 to 1981.
- E: Keys F: Hydroelectric Plants
- G: Thermal Plant H: Substation
- I: Switching Station J: — Transmission Line (154 KV)
- K: ■ Transmission Line (275 KV) L: ▨ Transmission Line (500 KV)

- | | | |
|------------------------|---------------------|-----------------------|
| a: Nanao Thermal P. | b: Shin-Noto | c: Toyama Shinkō T.P. |
| d: Kita-Kanazawa | e: Shin-Toyama | f: Toyama T.P. |
| g: Toyama | h: Eguchi | i: Furan |
| j: Shin-Chūjisan | k: Kita-Sasazu | l: Wada 2nd |
| m: Minami-Kanazawa | n: Kaga | o: Maki |
| p: Ikenowo | q: Higashimachi | r: Tochio |
| s: Shin-Komatsu | t: Fukui Thermal P. | u: Mikuni Kyōdō T.P. |
| v: Kitanōjō | w: Shin-Fukui | x: Matsuoka |
| y: Nishi-Katsubara 3rd | z: Yugami | |
| aa: Nagano | ab: Shin-Buyū | ac: Shin-Suruga |

A Z B B B

E (単位: MW)

Case	SI (MW/M)	SI	E
D	1,228	936	1,188
E	1,644	1,608	1,917
F	2,672	2,544	3,105
G	845	1,226	1,293
H	3,517	3,770	4,698
I	323	711	784
J	3,040	4,181	5,342

ORIGINAL PAGE IS OF POOR QUALITY

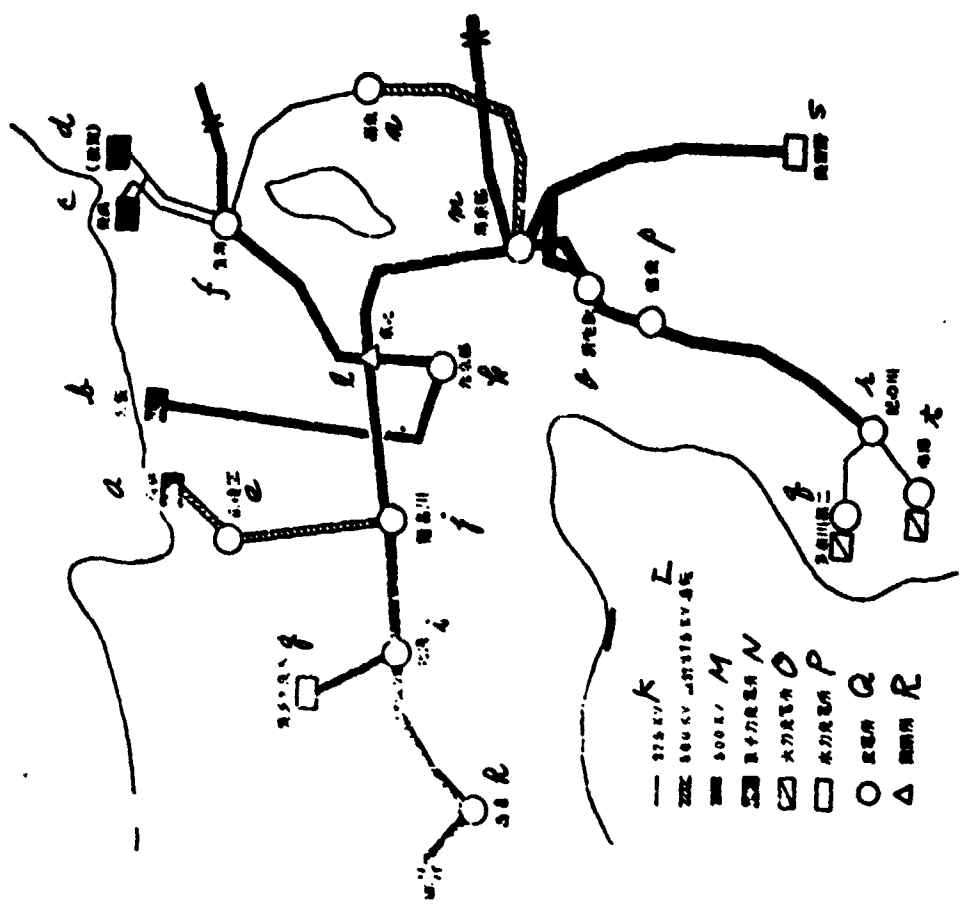

Fig. III-17. Transmission Lines Over 500 Thousand kW in Kansai District.

Keys to Fig. III-17.

A: Construction Budget	B: Unit=100 million yen
C: Fiscal Year	D: Power Station
E: Transmission Line, Substation, Distributing System or the Like	F: Sub-Total
G: Innovation Work or Others	H: Total
I: Fuel Cost	J: Grand Total
K: — 275 KV	L /// 275 KV Operation, 500 KV Deaign V.
M: ■ 500 KV	N: Nuclear Plant
O: Thermal Plant	P: Hydroelectric Plant
Q: Substation	R: Switching Station

a: Takahama	b: ⁻ Osaka	c: Mihama
d: Suruga	e: Shin-Ayabe	f: Sun-Nan
g: Oku-Tataragi	h: Nishi-Hari	i: Hoku-Setsu
j: Ina-Gawa	k: Nishi-Kyoto	l: Kei-Hoku
m: Ko-Toh	n: Minami-Kyoto	o: Shin-Ikoma
p: Shinki	q: Tana-Gawa 2dn	r: Ki-no-Gawa
s: Oku-Yoshino	t: Shōnan	

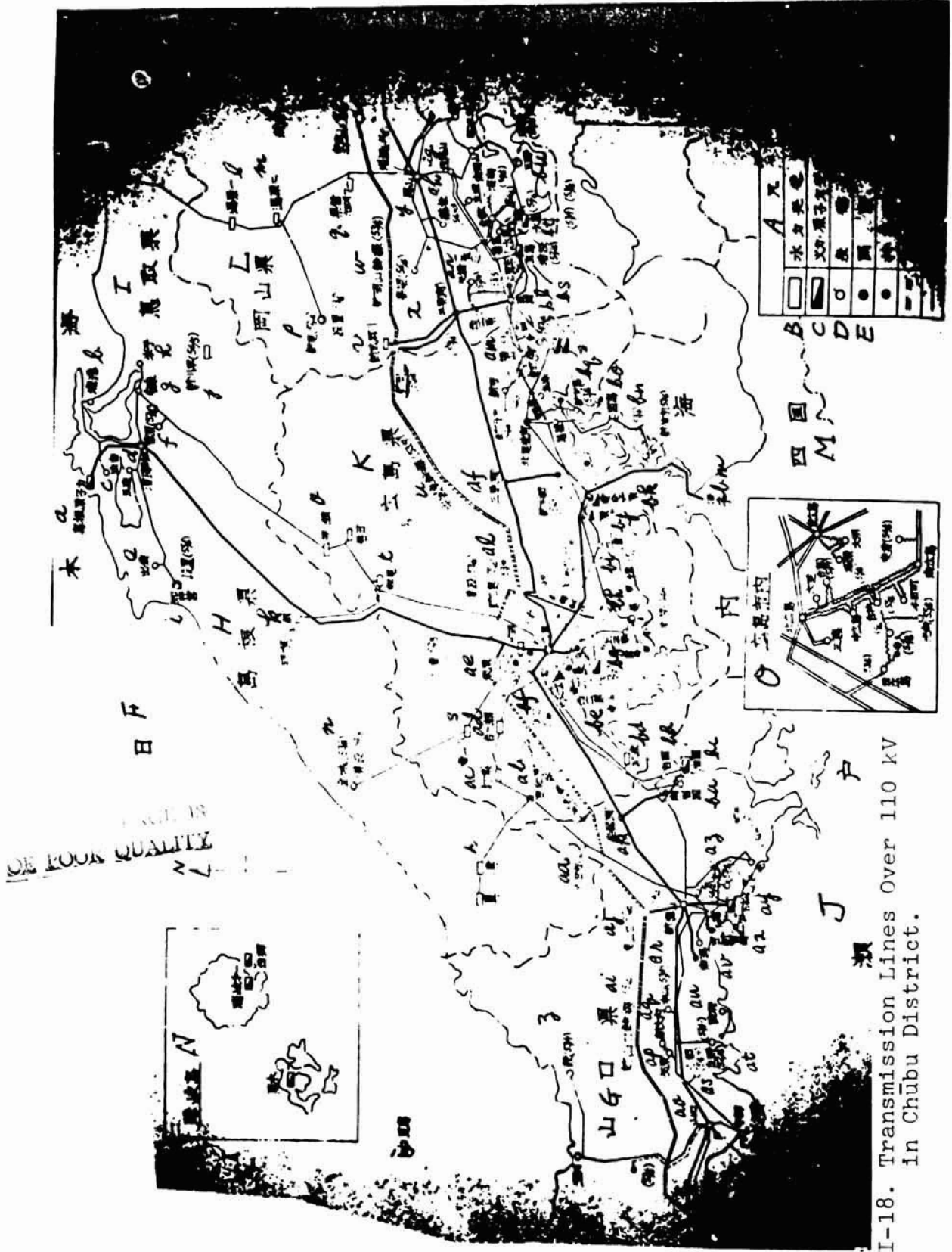

Fig. III-18. Transmission Lines Over 110 kV in Chūbu District.

Keys to Fig. III-18.

A: Keys	B: Hydroelectric Plant	C: Thermal/Nuclear P.
D: Substation	E: Switching Station	F: Japan Sea
G: Yamaguchi Prefecture	H: Shimane Prefecture	I: Tottori Prefecture
J: Seto Inland Sea	K: Hiroshima Prefecture	L: Okayama Prefecture
M: Shikoku	O: Hiroshima City	N: Iki Islands
a: Shimane Nuclear P.	b: Sakai-Kō	c: Sumiyoshi
d: Matsue	e: Izumo	f: Sugawara
g: Anrai	h: Yonago	i: Chiigū
j: Niikawa-Daira	k: Se	l: Yubara 1st
m: Yubara 2nd	n: Kanejō	o: Kannose
p: Niimi	q: Asahikawa	r: Sumikawa
t: Kamami	u: Chūgoku East M.L.	v: Shin-Naribagawa
w: Shin-Okayama M.L.	x: Kōno	y: Okayama
z: Hagi	s: Takayama-Gawa	
aa: Mukkaichi	ab: Yoshinoseki	ac: Dari
ad: Yoshinose	ae: Nanbara	af: Mihara
ag: Sōsha	ah: Nishi-Okayama	ai: Shin-Yamaguchi M.L.
aj: Higashi-Yamaguchi	ak: Iwakuni	al: Shin-Hiroshima
am: Fukuyama	an: Yagake	ao: Yamaguchi
ap: Yanobara	aq: Shin-Ohuchi	ar: Nakayama
as: Ogōri	at: Shōno	au: Bōfu
av: Nangō	aw: Shin-Tokuyama	ax: Nisshin-Shūnan
ay: Shimomatsu	az: Suetake	
ba: Minami-Iwakuni	bb: Iwakuni	bc: Iwakuni
bd: Tsukuba	be: Nishi-Hiroshima	bf: Kita-Hiroshima
bg: Kami-Hirahara	bh: Kure	bi: Mitsu
bj: Orihara	bk: Takehara Power S.	bl: Shin-Hiroshima
bm: Iyo	bn: Innoshima	bo: Shin-Hazamazima
bq: Matsunaga	br: Kasaoka	bs: Tamanoshima
bt: Mizushima	bu: Tamano	

ORIGINAL PAGE
OF POOR QUALITY

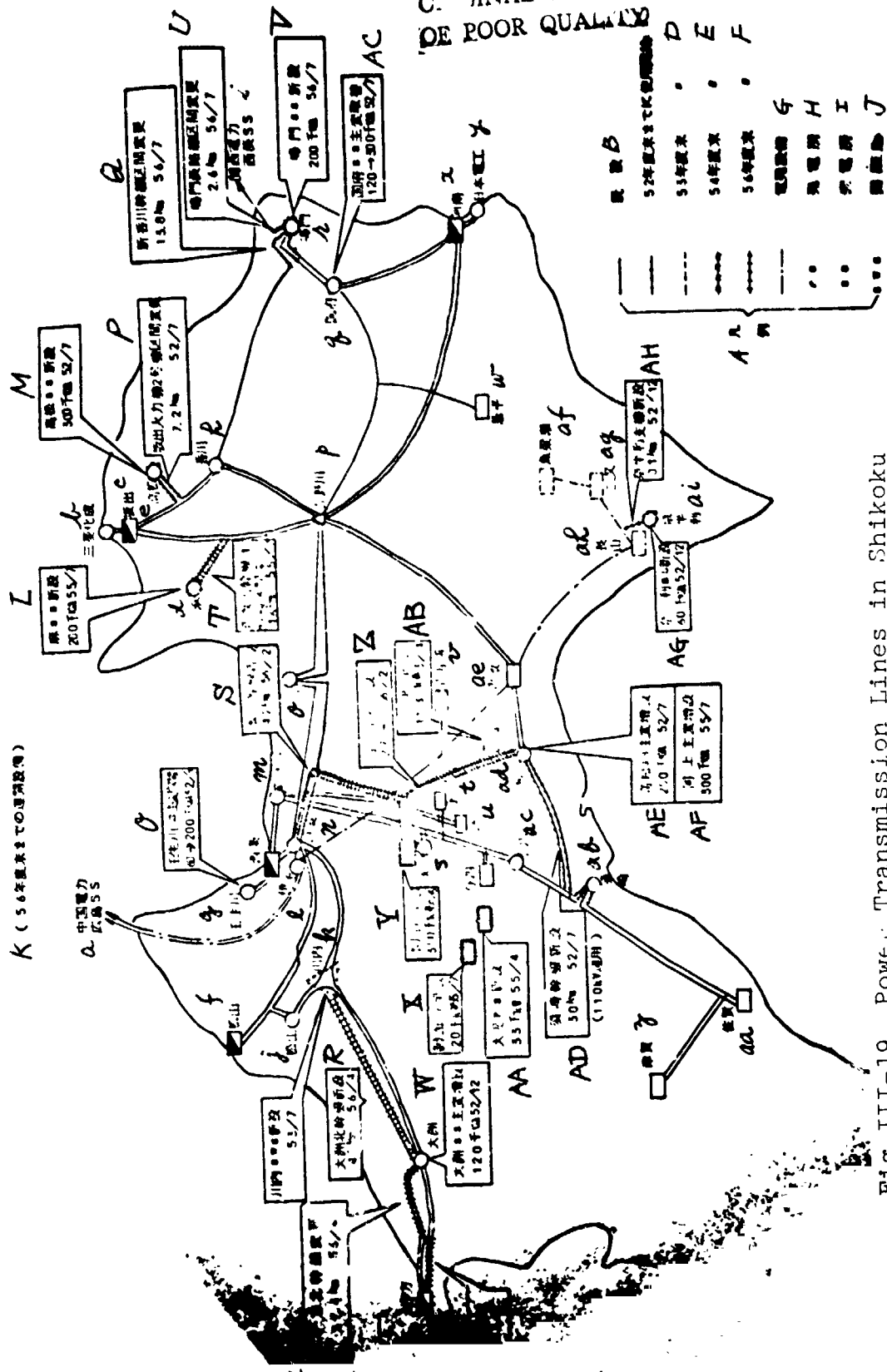

Fig III-19. Power Transmission Lines in Shikoku
(Facilities Whose Operation Start By the End of 1981.)

(56年度末までの運用設備)

Keys to Fig. III-19.

- | | |
|--|---|
| A: Keys | B: Construction Completed |
| C: Operation will Start by the End of 1977. | |
| D: Operation will start by the End of 1978. | |
| E: Operation will start by the End of 1979. | |
| F: Operation will start by the End of 1981. | |
| G: Facilities of Electricity Development. | |
| H: Power Station | I: Substation |
| | J: Switching Station |
| K: (Stations Which Starts Operation by the End of 1981.) | |
| L: Asa S.S., New Construction
200 Thousand KVA, July, 1980 | M: Takamatsu S.S., New Construction
300 Thousand KVA, July, 1977 |
| N: Kawauchi S.W.S., New Construction
July 1978 | O: Minobugawa S.S., Overhaul
from 60 to 200 Thousand KVA
July, 1977 |
| P: Sakaide Thermal P. Line, 2nd
Section Alternation, 7.2 km
July, 1977 | Q: Shin-Kagawa Main Line, Section
Alternation, 13.8 km, July 1981 |
| R: Ohsu Kita Main Line, New Constr.
47 km, April, 1981 | S: Honkawa New Main Line, New Constr.
42 km, Feb., 1980 |
| T: Shin-Sakaide 1st, Section Altntn.
16 km, July 1980 | U: Naruto/Awaji, Section Altntn.
2.6 km, July, 1981 |
| V: Naruto S.S., New Construction
200 Thousand KVA, July, 1981 | W: Ohsu S.S., Extension
120 Thousand kVA, Dec., 1977 |
| X: Menzan P.S., New Constrct.
20 Thousand KVA, July, 1980 | Y: Honkawa P.S., New Constrct.
300 Thousand KVA, June, 1981 |
| Z: High Voltage Main Line, New Cnstr.
29 km, Feb, 1981 | |
| AA: Ohwatari P.S., New Cnstrctn.
33 Thousand KW, April, 1980 | AB: Tenzu P.S., New Cnstrctn.
11.8 Thousand KW, Feb., 1980 |
| AC: Kohfu S.S., Main Equip. Altntn.
from 120 to 300 Thousand KVA
July, 1977. | AD: Suzuki Main Line, New Cnstrctn.
30 km, July 1977 |
| AE: Kochi S.S., Expansion
200 Thousand KVA, July, 1977 | AF: Kochi S.S., Expansion of Main Trsf.
300 Thousand KVA, July, 1980 |
| AG: Nanbari S.S., New Cnstrctn.
60 Thousand KVA, DEC., 1977 | AH: Nanbari Branch Line, New Cnstrctn.
0.1 km, Dec., 1977. |
| a: To Chugoku Electricity. Hiroshima S.S | b: Mitsubishi Kasē |
| c: Sakaide | d: Asa |
| e: Takamatsu | f: Matsuyama |
| g: Mibu-Gawa | h: Kagawa |
| i: To Nishi-Tan S.S., Kansai Electricity | j: Matsuyama |
| k: Kawauchi | l: Iyo |
| m: Niihama | n: Mishijō |
| o: Mishima | p: Yoshino-Gawa |
| q: Kokufu | r: Naruto |
| s: Ohashi | t: Buichi |
| u: Somyo-Ura | v: Somyo-Ura |
| w: Kage-Daira | x: Nippon Denko |
| aa: Saga | ab: Suzuki |
| ac: Sagawa | ad: Kōchi |
| ae: Shinkai | af: Uwahase |
| ag: Futamata | ah: Nagayama |
| ai: Nabari | |

III-1-6. Problems of Heavy Cargo Transport in Connection with Rationalization Plan of the Japanese National Railways.

/68

According to the rationalization plan of the Japanese National Railways, the condition planned for October, 1978 is as follows:

(a) Reduction of Freight Train Station.

Freight train stations will be reduced from 1,600 (at present) to 1,000 (63 %) by the end of the year 1980. The time schedule for the reduction is:

Year	1977	1978	1979/1980
No. of Stations	180	96	300

(b) Freight Train Schedule.

The 4,600 trains scheduled at present will be reduced by 1,100 trains to become 3,500 trains (76 %). The reduction of locomotives and freight cars is planned as follows:

Locomotives: from 3,300 units to 2,700 units (81 %),
a 600-unit reduction.
Freight Cars: from 120 thousand cars to 100 thousand cars (80 %),
a 20 thousand-unit reduction.

(c) Freight Cars.

Large-size heavy freight cars are going to be successively phased out, starting with the oldest cars (ones older than 20 years). The 41 large-size cars belonging to the Japan National Railways are scheduled to be reduced to 19 cars by 1980. 22 cars will be phased out in the meantime. (According to the latest agreement, however, the overhaul of these cars is planned for 1977 and 1978, and their phasing out will not be done until the middle of 1979.)

36 large-size cars are possessed by the maker of the products to be transported. Supplementation of the cars discontinued by the Japan National Railways is, however, difficult due to the conditions set by the makers. At the present stage, heavy cargoes over the road transportation limit of 30 to 60 tons can depend on transportation means other than the railway system. Hence, an LTA transportation system is worth serious consideration in this respect, too.

Estimated Cost of Cars Which are Scheduled to be Discontinued by 1980.

Type	Load	Estimated Unit Price	x	Units	Total Price
Siki 40	30 tons	30 million yen	x	3	90 million yen
Siki 70	30	30	x	8	240

- continued -

Siki 80	30	30	x	4	120
Siki 90	30	30	x	3	90
Siki 100	80	80	x	1	80
Siki 500	100	80	x	1	80
Siki 550	50	70	x	2	140
Total				22	840

Demad for Heavy Cargo Temporary Transportation
in 1978

69

Ultra Large-Size Cargoes: 132
Type A Cars: 73

Besides the above demand, there are 12 planned construction sites for power substations (with more than 500 thousand kW capacity) which require heavy freight temporary transportation in 1978 to 1981, and there are 19 construction sites of pumped-strage large-scale power plants planned up to 1984 which will also demand temporary heavy freight transportation.

III-1-7. Bridge Building, Penstocks, and LTA.

(This section is based on the interview with Mr. Ukon Toriumi, director, Division of Bridge Building, Nippon Kōkan Company, Ltd.)

The annual demand for bridge building and penstock related products is about 400 thousand tons.

In product design of bridge related materials, assembling has the first priority. Next to this, the manufacturing process in factories and the question of transportation must be considered. Recently, in order to use sea transportation means for heavy products, **sea-side** grounds have been preferred in the selection of the factory sites. However, the heavier the product, the more important the assembling design is. The basic design process must include calculation of the stress during assembling as well as the design stress when installed. Therefore, the stress of the bridge bodies during assembling and transportation must be precisely calculated and controlled in a well-organized system. In addition, the factor of the safety of materials during assembling must not be overlooked either. Due to the uncertainty associated with the building techniques, an effort to attain the maximum safety must be made. In this respect, pre-assembling in factories is preferable, since it will reduce construction site work and will eliminate many uncertain factors. Pre-assembled large block systems are the most desirable in this respect, and using these systems, assembling immediately after transportation will become possible. In such a system, a 50-ton class block is transported. Recently, even welding work at construction sites has been under strict control of working conditions. Since a 300-ton ground crane was developed, transportation of 50-ton

blocks has been carried out without difficulty. On the sea, a 3,000 ton floating crane is used at present. These examples of progress in means of transportation will continue to encourage pre-assembled large-block systems. Large block systems are also advantageous in their ability to reduce the materials necessary for assembling work at the construction site.

The blocks of a tower are usually less than 50 tons in weight. In the most common case, blocks of 15-m length and 10-ton weight are transported, while in one recent case, a 20-m x 7-m, 30-ton block was transported. The recent trend concerning the penstocks of hydroelectric power plant dams is to replace 1-m, 2-ton blocks by 6-m, 12-ton blocks. Similarly, in the case of bridge beams, 1-m, 1 to 2-ton blocks are being replaced by 15 to 30-m, 30-ton blocks.

The annual product of 400 thousand tons corresponds to the cost of about 250 billion yen (625 thousand yen per ton). 85 % is transported by ground transportation means, and 14 to 15 % by ship. Products up to 50 tons are transported by trailer. The normal weight carried by trailers is 20 tons. The transportation cost of bridge beams is 10 to 15 thousand yen per ton. The construction cost is approximately 10 % of the product price and about 62.5 thousand yen per ton.

According to the survey by the Japan Association of Bridge Construction, the annual demand for bridge construction is 320 thousand tons and 2,000 bridges. One third of this demand is for bridges in urban areas. The demand is itemized below:

Regional Construction Bureau	33,500 tons
Development Bureau	6,000
Japan Road Corporation	55,000
Honshū-Shikoku Bridge	60,000
Metropolitan Transportation	67,000
Hanshin Transportation	
Railway Bridge	36,000
Others	62,000
Total	320,000

The demand for penstocks and related materials is estimated to be at most 100 thousand tons per year. Usually, a 6-m, 12-ton block of penstock is carried by a truck or the like, and the transportation cost is 5 to 10 thousand yen per ton. As an indication of the quantity of penstocks used in one plant, the following examples will be of use: Second Numazawa-Mura Pumped-Storage Power Plant (with 460-thousand-kW output) used 7,000-ton penstocks. Oku-Yoshino Pumped-Storage Power plant used the same quantity of penstocks. These examples suggest that an LTA transportation system would be an appropriate means of transporting these materials.

In addition to the penstocks, press-trusses and concrete beams are heavy materials transported to the construction sites. The annual

demand for these materials is 2,000 of 20-m³ 50-ton blocks and about 100 thousand tons.

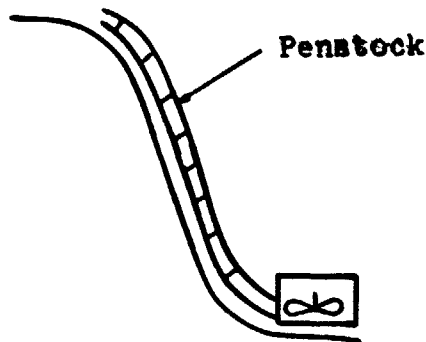

Fig. III-20.

Installation of Penstock.

III-1-8. Heavy Cargo Transport in Dam Construction and LTA.

(This section is based on the interview with Mr. Tomo Narita, Technical Committee Member, EDPC International.)

In the construction of a dam, the decision to construct is made after survey and planning is done, and practical designs are drawn. Then, after a contract is made, actual construction work is begun. A common schedule of dam construction is briefly described below:

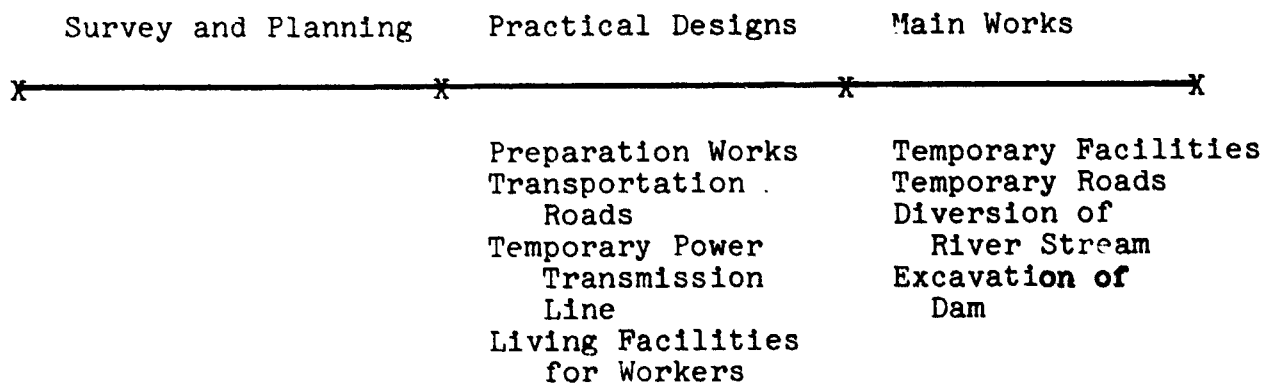

The power station and dam construction site of Owashi Hydro-/71
 electric Power Plant is located at the 20-km point from Owashi-Machi
 (a town). If the transportation of heavy material by LTA were possible,
 a variety of benefits might be obtained with respect to road and dam
 construction.

A clearer example is the construction of Ohtsuna Power Plant. Based on a decision by the Conference of Electric Power Development, after survey, planning and design studies, a contract was made in December, 1965 and the plant began to be operated in December, 1968. The construction site is shown in Fig. III-21. Construction equipment and workers

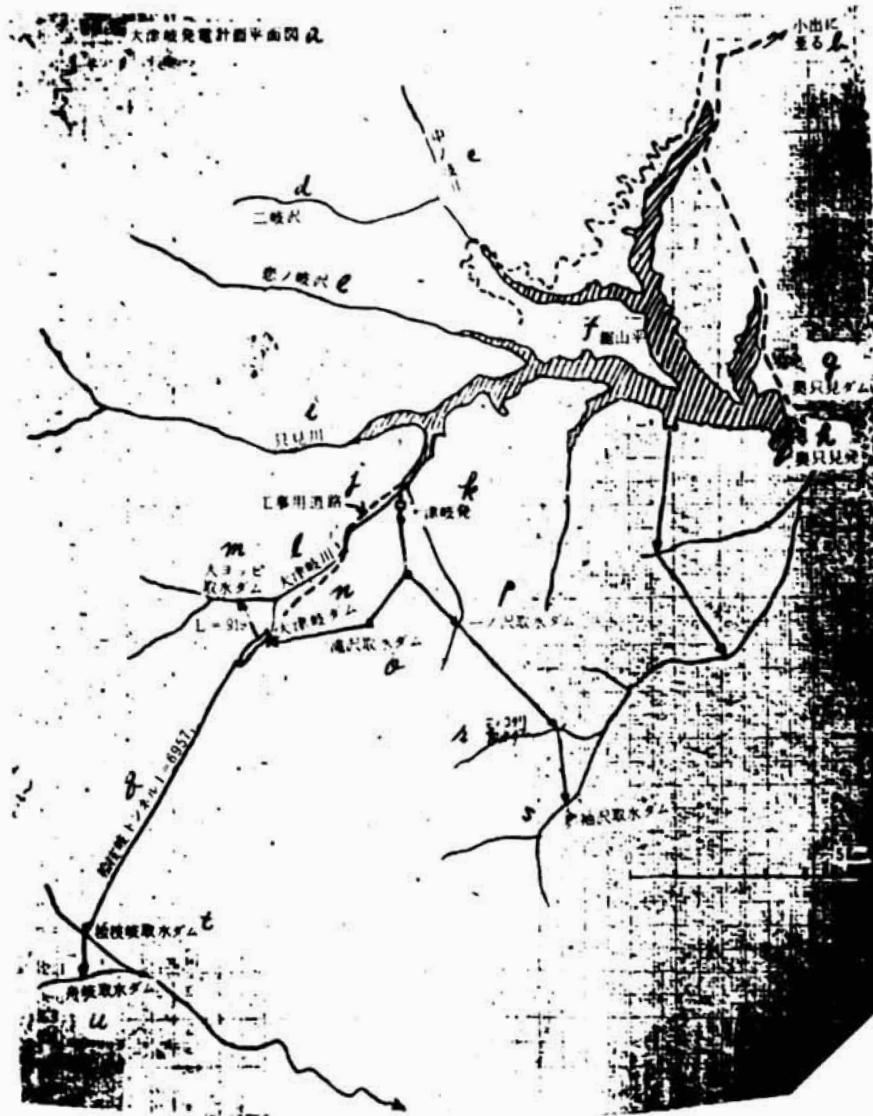

Fig. III-21. Oku-Tadami Hydroelectric Power Plant.

Key:

- | | | | |
|---|-----------------------------------|--------------------------------|-------------------------------|
| a: Plan of Oh-Tsumata Power Generating Stations | b: To Koide | c: Nakanomata-Gawa | d: Futamata-Zawa |
| e: Koinomata-Zawa | f: Nokogiri-Yama-Daira | g: Oku-Tadami Dam | h: Starting Point: Oku-Tadami |
| i: Tadami-Gawa | j: Road for Construction | k: Starting Point (Oh-tsumata) | l: Ohtsumata-Gawa |
| m: Dai-Yoppi Water In-Take Dam | n: Ohtsumata Dam | o: Takisawa Water In-Take Dam | q: Hinoemata Tunnel |
| r: Monokokuri Water In-Take Dam | s: Oku-Sodezawa Water In-Take Dam | t: Hinoemata Water In-Take Dam | u: Funamata Water In-Take Dam |

ORIGINAL PAGE IS
OF POOR QUALITY

were transported on the dam water of Tadami Power Station and through a temporary construction road, to the dam construction site. The snow-fall in the winter season is about 6 to 7 m in this area. The ice melts late in March and the snow begins to melt in May. Although the contract was made in December, 1965, the dam-site construction work did not begin until June, 1966 when the temporary construction road was completed. The road construction began in March, 1966. If the equipment and worker transportation could have been accomplished by using an LTA, the period from December, 1965 to June, 1966 would not have been wasted. For the construction of this dam, helicopters were also used to transport equipment. The most significant use of helicopters was construction of the longest tunnel, 6,957-m Hinoemata Tunnel, in the transportation route. After the trees were cut down, a heliport was constructed using the necessary equipment which was transported by helicopter. This work started on April 20, 1966. After the snow on the heliport was removed on May 1, 1966, transportation by large-size helicopters began on May 5, 1966. Compressors, diesel engines and other necessary equipment had been transported by the large-size helicopters, when the excavation of the tunnel started on May 21, 1966. /72

The construction of Omcro Power Station is another example. The dam construction site was about 7 km from the construction base. By means of large-size helicopters (Sikorsky S58-C) which were used for 75 days, the total weight of 864 tons was transported. On the average, 4.16 rounds of transportation were done in an hour and the average load transported per round was 0.7 ton.

On the other hand, in case of the Hasan Ugurlu dam, in Turkey, the contract was made on November 1, 1971 and a 145-m high 9000-thousand-m³ rock-fill dam was scheduled to be filled with water. A road was constructed for building the dam top. This road was constructed on the left bank of the river and was 140 m high. It is 2 km long and is connected with an existing road to Carsamba.

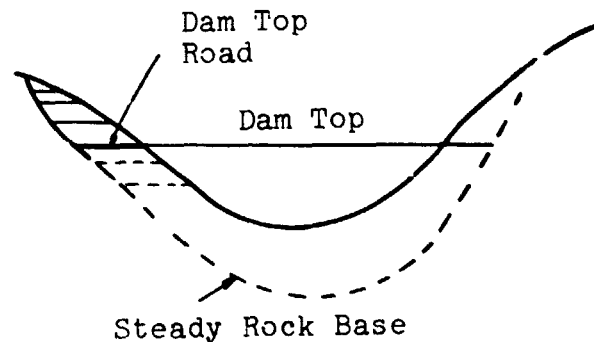

(See Fig. III-22) The construction of the road began in 1972 and the dam construction work started in the middle of July, six months later. If the workers and the equipment could have been transported to the left bank by means of LTA for the construction of the dam top, the construction period might have been shortened by six months. Moreover, the construction of a temporary stream diversion way on the left bank might have been completed in a shorter period of time.

In constructing a rock-fill dam, the soil is excavated to the rock base, designated by a broken curve in the above figure. Without the dam top road, transportation of equipment and the soil evacuation cannot be performed on the left bank.

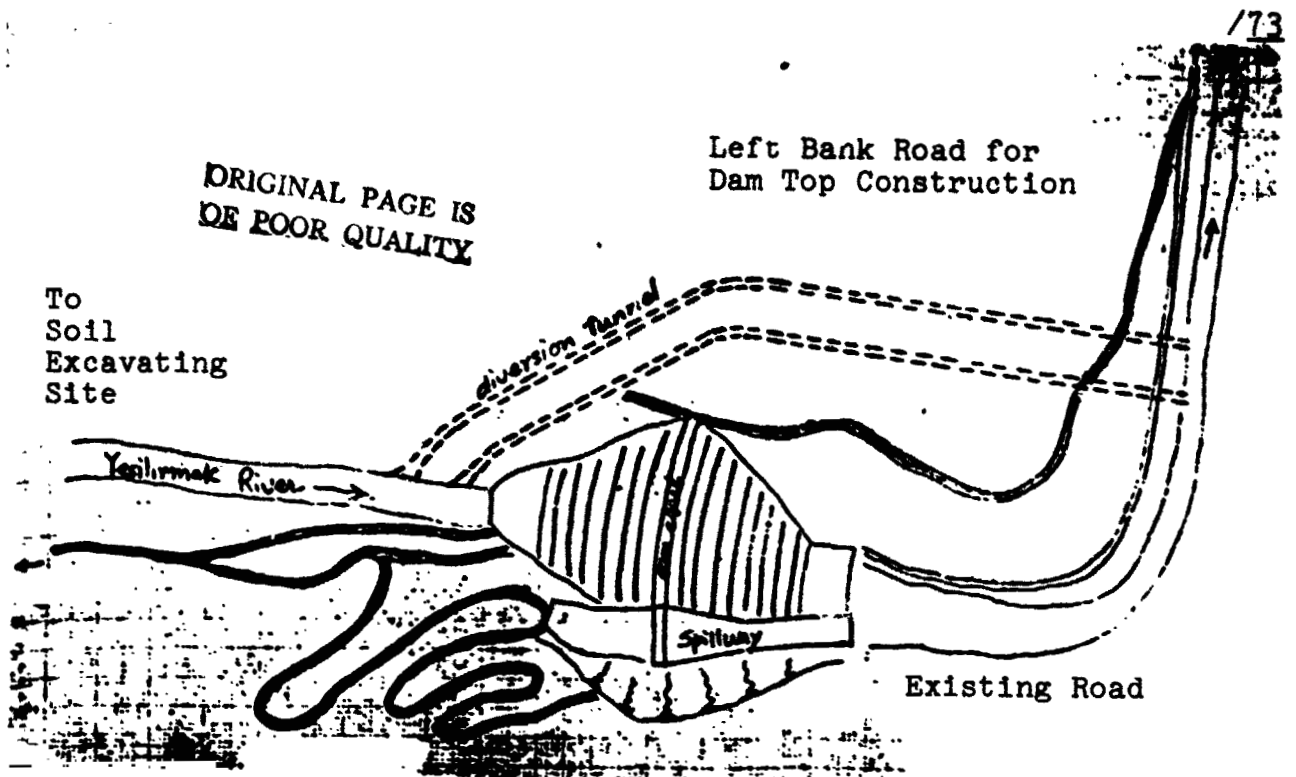

Fig. III-22. Hasan Ugurlu Dam, Turkey, and the Neighborhood.

Key:

- a: Siquirres Plan
- b: the Atlantic Ocean
- c: National Road
- d: Limon Harbor
- e: Upper Beles Plan
- f: National Road
- g: To Addis Ababa

ORIGINAL PAGE IS
OF POOR QUALITY

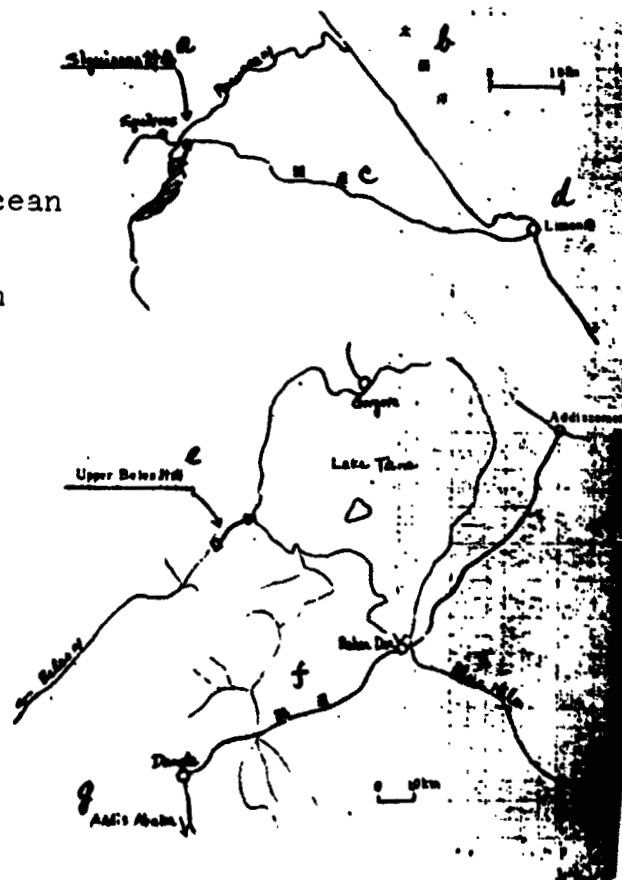

Fig. III-23. Upper Beles Plan of Ethiopia.

In the case of the Upper Beles Plan in Ethiopia, a survey of the area for a planned 200-thousand-kW hydroelectric plant was carried out. (See Fig. III-23.) The area is 300 km away from Addis Ababa and 60 km from Daugla. The road from Daugla is a winding mountain road and the actual distance along the road is $60 \text{ km} \times 1.4 = 84 \text{ km}$. It is conceivable that the utilization of LTA might have greatly facilitated the work of surveying in such a mountainous area.

New transportation means using LTA may even eliminate the need for road construction. In the case of the previously mentioned Hasan Dam, 60-ton dump trucks were going to be used according to the original plan. However, for some reason, 35-ton and 45-ton dump trucks were used instead. Consequently, the construction work on the right bank was significantly delayed. In a case like this, if an LTA system had been used, such a delay might have been avoided. /74

In some cases, dam construction work includes construction of stream diversion tunnels. In these cases, tunnels are excavated from one side. However, if an LTA system could transport equipment and workers, tunnel excavation from both sides might be possible and the construction period might be shortened, without the need for additional roads for excavation of tunnels from both sides. Furthermore, an LTA system might eliminate the necessity for the road for transportation of construction equipment between the power station and the dam or between the power station and the water pool.

Besides the above-mentioned potential advantages of using LTA's, the following points should be added:

1. By use of LTA's, the road reinforcement and repair cost could be reduced. Such a cost is inevitable when heavy equipment such as transformers, water wheels and water wheel generators are transported on a road. Moreover, in some cases, the transportation limitations might be modified and heavier or larger equipment could be transported. By using a larger capacity of generator unit or equipment, the amount of necessary equipment will be reduced.
2. The efficiency in heavy cargo handling at the harbor would be improved. For example, the unloading of equipment for 150-thousand-kW Alleluna Power Station in Costa Rica had to be done by means of barges.
3. In the construction of Oku-Kiyotsu Pumped-Storage Power Station, transportation efficiency was improved by using 60-ton dump trucks. These trucks have a deadweight of 60 tons and a net load of 60 tons. The roads travelled by such a heavy car must be reinforced with particular care. The load and deadweight of the dump truck ordinarily used is about 30 tons. The use of LTA's would reduce the reinforcement and repair cost significantly.
4. Ethiopia has many sites where 2,000 to 3,000-kW hydroelectric power plants are under consideration. At present, the road problem is an obstacle which is hindering the development plans. In

general, a new LTA system would be very useful for water resource development in developing countries where transportation means are generally in poor condition. ~~Similar~~ circumstances can be pointed out in Middle or Near East countries.

- Weight of Civil Engineering Equipment for Construction of Hydroelectric Power Plants -

The weight of civil engineering equipment was already shown in Section III-3. The truck has a capacity of 32 tons at most. The bulldozer has a truck unit of 36 tons or less and is 50 tons or less including other attached equipment. It is desired that the LTA system to be developed provide these capacities.

- The Merits of Construction Period Reduction for Hydroelectric Plant Construction -

In general, the construction cost of a hydroelectric plant includes 7 to 8-% interest and 5 to 6-% construction expenditure. If the total construction cost is 50 billion yen, the interest plus the construction expenditure is $50 \text{ billion yen} \times 13 \% = 6.5 \text{ billion yen}$. Then, if the construction period, say 5 years, is reduced by six months, $6.5 \text{ billion yen} \times (6/60) = 650 \text{ million yen}$ will be saved. The saved cost is 1.3 % of the total cost, 50 billion yen. The merit of the construction period reduction by means of LTA is illustrated by the above example.

III-1-9. Transport Data for Reference in Connection with LTA Use.

In Japan, even when LTA's are used for heavy cargo transportation, it will be economically efficient to use coastal marine transportation means to the shore nearest the construction site. This is understandable when one realizes that most thermal or nuclear plants in Japan were constructed at sea-side sites in order to alleviate the problem of transporting equipment, and when one realizes that 50 % of the total transportation is coastal marine transportation. The greatest problem in heavy cargo transportation by means of coastal marine transportation is the unloading and loading of the cargo. These harbor works are very costly. If this problem can be solved by the efficient use of LTA's, an excellent economical transportation system will be established, in which heavy cargo is transported to the nearest harbor by ships and then transported to the construction site by LTA. /15

In a case of plant transportation in Kyūshū District, in 1974, a total weight of 2,800 tons of plant products was transported by ship from the Tokyo-Yokohama area to Kyūshū District, and after unloading at the harbor, it was then transported by land via a 21-km route. The marine transportation cost was 57 million yen and the so-called unit transportation cost was a little over 20 thousand yen per ton.

According to a recent estimation, if 3 packages of 160-ton transformers are transported from the Tokyo-Yokohama area to a harbor in Kyushu District and then by land along a 22-km road to the installation

site, the transportation cost will be 44 thousand yen per ton. If the land transportation cost and unloading/loading cost are not included in the calculation, per-ton cost is about 27 thousand yen.

According to the above data, cost of transportation by ship to the nearest harbor can well be estimated at around 30 thousand yen per ton or a little less.

III-1-10. Anticipated Annual Demand for LTA.

According to "Estimated Operating Cost of Sky Crane," which is among the separately provided reference literature, the unit transportation cost by a 70-ton Sky Crane is estimated to be 70 thousand yen per ton in a 50-km transportation operation, assuming that the annual flight is 1,200 hours and the loaded flight is 600 hours. Based on this data, the demand for the transportation of the previously mentioned heavy equipment is estimated as follows:

- (1) Pumped-Storage Power Plant.
Annual Heavy Cargo Transportation (Over-20-Ton Equipment)
9,000 to 10,000 ton
If 40 ton x 250 cases,
 $4 \text{ H} \times 250 = 1,000 \text{ H/year.}$
- (2) Common Hydroelectric Power Plant.
Annual Heavy Cargo Transportation (Over-20-Ton Equipment)
23 Cases
 $4 \text{ H} \times 23 = 92 \text{ H/year}$
- (3) Geothermal Power Plant.
Annual Heavy Cargo Transportation (Over-20-Ton Equipment)

If 20 ton x 25 cases,
 $4 \text{ H} \times 25 = 100 \text{ H/year.}$
- (4) Power Transmission Lines.
250,000-ton Helicopter Transportation per Year.
10 ton x 25,000 rounds
 $(1/10) \text{ H} \times 25,000 = 2,500 \text{ H}$
If 50 % is in an area where LTA cannot be used,
 $= 1,250 \text{ H}$
- (5) Power Substations. /76
30 ton x 40 cases per year
60 ton x 300 cases per year
 $4 \text{ H} \times 340 \text{ cases} = 1,360 \text{ H.}$
If 60 % is in the area where LTA cannot be used,
 544 H.

With respect to the above-mentioned five kinds of plants, the estimated total annual demand is:

2,950 H; 3,000 H.

Besides the above, it is understandable that the advantages of LTA transportation will be evaluated in every case and will induce demand, also with respect to the transportation of heavy equipment for bridge construction, penstocks, dam construction and others.

III-2. Current State of Large-Size Helicopters and Problems at Issue. /77

Table III-9 and Fig. III-24 show representative middle- and large-size helicopters which are available at present. When payload is not listed, the difference between fully loaded weight and dead weight can be thought of as the payload plus fuel. Needless to say, the payload is reduced when the flight distance is increased. At present,

Table III-9. Representative Middle- and Large-Size Helicopters.

a 機 種 名	b Engine名 c 馬 力 HP	全備重量 d ton	空虛重量 e ton	最大速度 f (km/h)	飛行距離 g km.	有用荷重 h ton	航続 時間
1 S-61	GE T58-710 1,500×2	86	5.1	235	444	—	—
2 KV-107-2	GE T58-110 1,500×2	86	5.1	270	346	—	—
3 Sea King	R-R Gnome H1400-1 1,660×2	95	5.5	225	1,120	—	—
4 Mi 8	Izotov TV-2 1,500×2	12	—	245	493	4.0	—
5 SA321(S.Frelon)	Tur Turmo 307-60 1,570×3	13	6.8	275	829	—	—
6 S-65(CH-53F)	GE T64-GE-415 4,380×2	19	11.6	314	965	3.6	—
7 CH-47C(Chinook)	Lyc. T55 ^c -L-11D 3,750×2	21	10	306	695	—	—
8 S-64F(Skycrane)	P&W JFTD12A-5A 4,500×2	21	8.9	193	370	10.0	—
9 MIL Mi 6	Soloviev D-25V 5,500×2	42	—	299	634	—	—
10 MIL Mi 10	Soloviev D-25V 5,500×2	43	27	200	249	15.0	—
11 MIL Mi 12	Soloviev D-25V 5,500×4	97	67	260	260	30.0	—

Keys:

- a: Name of Model
- b: Name of Engine
- c: Horse Power HP
- d: Fully Loaded Weight (ton)
- e: Deadweight (ton)
- f: Maximum Speed (km/hour)
- g: Flight Distance (km)
- h: Payload (ton)
- i: Endurance Flight Time

ORIGINAL PAGE IS
OF POOR QUALITY



BOEING-VERTOL CH-47C



SIKORSKY S-64E

ORIGINAL PAGE IS
OF POOR QUALITY



MIL MI-6



MIL MI-10

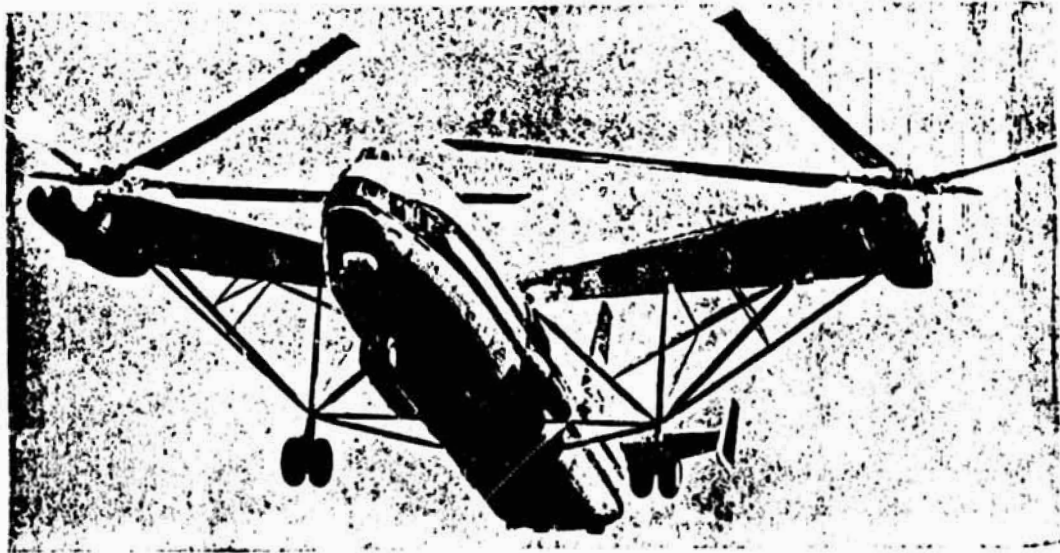

MIL MI-12 (V-12) (HOMER)

Fig. III-24. Representative Middle- and Large-Size Helicopters.

- continued -



MITSUBISHI S-61



KAWASAKI-BOEING KV 107-118



WESTLAND SEA KING

**ORIGINAL PAGE IS
OF POOR QUALITY**

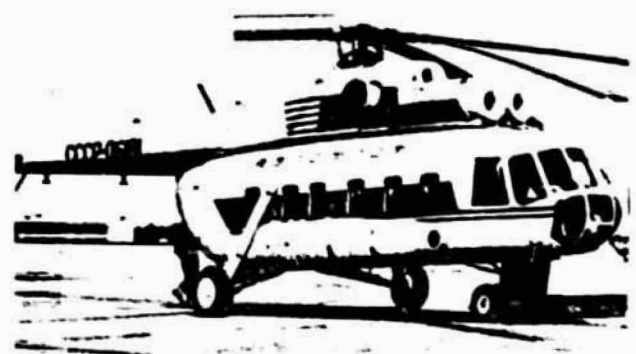

MIL MI-8



SUD SA-321F SUPER FRELON



SIKORSKY CH-53D

Fig. III-24. Representative Middle- and Large-Size Helicopters.

two types, S-61 and KV 107, are used in Japan. These types of helicopters can suspend a load of about 3 tons. The flight time is only 1 to 1.5 hour.

Among the helicopters which are available within the free nation bloc, S-64 has the maximum payload, 10 tons. On the other hand, in the Soviet Union, the 15-ton payload class of helicopters is now used for practical purposes and test model Mi-12 is estimated to be able to carry 30 tons or more. Although this class of helicopters was once planned for use in the U.S.A., the plan will probably be discarded after several test models are manufactured. Therefore, helicopters cannot be used for transportation of heavy cargo which is more than 10 tons in weight, in the near future in Japan.

However, helicopters have actually been very important means of cargo transportation, and they will remain so in the future as well. In an operation for which helicopters have most been used, load of around 1 ton or less are transported with great frequency within a short period of time, 20 to 30 minutes at most. The loading and unloading takes very little time. Usually, a load is prepared, and is equipped with a rope or a wire before a helicopter arrives. Then, the helicopter descends and stops over the load. When the helicopter is hovering, the suspending hook of an outside hoist is stretched and engaged with the load. At the time, if the helicopter is middle-size, the pilot adjusts the position of the helicopter according to the instructions given by a ground crew, so that the hook may be easily engaged with the load. The instruction is given to the pilot in a way similar to a crane operation in which a person working on the ground gives instructions to the crane operator. In the case of large-size helicopters, an assistant crew member is on board and is in charge of adjusting the position of the hook. After the pilot roughly determines the position of the hook, the assistant crew member, watching the load, positions the hook precisely. The adjustment of the hook's position is done by means of a joy stick. In these operations, the helicopters are so stable that work members can attach the hook to the load under the helicopters with no danger. In other words, the helicopters are extremely **stabilized** and controlled. /80

When the load is suspended by the helicopter, it ascends according to the instructions of the ground crew and begins forward flight immediately. The helicopters do not need runways, although loading of the cargo needs a certain area of ground. As wide an area as possible is desirable for the loading ground. The reason is this: Although the helicopters are capable of ascending and descending vertically, they can land with more safety - for example, in case of emergency, when the engine stops abruptly - if they have a forward speed component. Moreover, less fuel is consumed if the helicopters move forward. After the loading is completed, the helicopters ascend to an altitude which guarantees the safety of the ground workers. However, as soon as possible, they start to move forward while ascending, for the reasons mentioned above. Therefore, it is desirable for a loading area not to be surrounded by tall obstructions, such as mountains or buildings, which may force the helicopters to ascent rapidly. Rapid ascent is dangerous as well as fuel consuming.

On the way to his destination, the pilot must make certain that the load does not **begin** swinging. The swinging of a load with growing amplitude will cause difficulty in maintaining the stability of the helicopter. Disorders in the air condition, sudden wind and others, induce the load swing. In order to prevent this, the helicopter must be sufficiently stable and have excellent control ability so that the pilot may maintain the desired movement of the helicopter at all times. The flying position in which control is most difficult is the hovering position in which the helicopter is loading or unloading a cargo, as mentioned before. Thus, if the helicopter can withstand a sudden wind to some extent, while in forward flight, stability and controllability ensure almost riskless travel.

Helicopters are not good for long flights. One reason is the shape of the wing. Helicopters have rotary wings which have a circular or disc shape **when in the air.** This shape of wing is not efficient in long flight. And in general, due to the constant vibration and the **nerve-wracking** task of piloting, helicopter pilots are apt to tire easily. **Moreover,** helicopters are not allowed to carry suspended loads above city or town areas and must choose a flight course over rivers, farming fields, or streams if they fly over the mountains, with a suspended load.

When a helicopter reaches its destination, ground workers watch the helicopter and its load. The helicopter then begins hovering according to the instructions given by the ground crew. After gradually lowering the load to the ground, the load is disengaged. Sometimes the helicopter itself descends. Usually this unloading procedure is easier than the loading one.

After completing this operation, the helicopter returns to the original loading spot. Sometimes it carries an empty bucket or the like. The helicopter is much easier to pilot on the return trip since it is not carrying the load. It is said that helicopters are used most efficiently when they make frequent round trips carrying a load each time, as described above, particularly in mountainous areas where truck transportation is difficult. As mentioned later, at present, since renting a helicopter is very expensive, ground transportation means such as trucks are used as much as possible, while helicopters are used only when no other means of transportation can be used. For example, in lumber-cutting, it would be convenient to transport lumber by helicopter directly from the mountain onto the ship decks. However, for financial reasons this type of transportation is not used unless the harbor is very close to the deforestation site. /81

The necessary costs for helicopter operation are described below: Table III-10 lists the rent per hour, including pilot, and the maximum load by middle- and large-size helicopters, which are most frequently used in Japan. As seen from this table, helicopter rental is very expensive. It is much more expensive than that of airplanes. The reasons are, first, the high price of helicopters themselves, and second, the high maintenance cost and low demand. Table III-11 includes the prices at which helicopters are sold. The average price per ton is 4 to 5 times more than that of airplanes. These high prices result from the complicated component consisting of a rotor, a dynamic part, and a

rotor driving means. In addition, the helicopter equipment must endure constant and intensive vibration. The vibration is much greater than that of airplanes. The material and manufacturing costs of helicopters are consequently very high.

With regard to the demand for helicopters, a strong trend of seasonal change is observed in Japan. In particular, the demand for small helicopters for farm work rises sharply during the season when insecticides are sprayed. It is now difficult for middle- and large-size helicopters to attract a stable demand. If the demand for them were stable, many helicopters of the same model could be maintained by each transportation company so that rents would be reduced due to the improvement in operational efficiency.

Table III-10. Summary of Economy and Performance of Representative Models of Helicopters.

Model Name	Maximum Load	Flight Time	Cruising Speed	Price of Helicopter	Rent
KH-4 (Small Size)	0.45	2.5	140	ca. 65	173
Bell 204B (Middle Size)	1.50	2.5	180	ca. 240	414
KV-107-2 (Large Size)	3.37	3.0	236	ca. 1000	688
	ton	hour	km/hour	million yen	thousand yen per hour

Table III-11. Fare and Rent of Helicopters.

/82

機 種	貸切運賃 (円/時)	c 旅客運賃		空輸料金 (円/時)	滞 留 料 金		備 考 註
		大 人	小 人		昼 間	夜 間	
(回 転 翼)					(円/時)	(円/泊)	i
H-300	130,000	1,030	720	117,000	79,000	34,000	(S)
G-2	146,000	1,030	720	133,000	78,000	34,000	(S)
G-2A	159,000	1,030	720	146,000	82,000	34,000	(S)
KH4	173,000	1,030	720	160,000	90,000	34,000	(S)
ALH	211,000	1,030	720	192,000	114,000	34,000	(S)
206(H-500)	220,000	1,030	720	201,000	126,000	34,000	(S)
ALH(315B)	297,000	1,030	720	268,000	166,000	41,000	(M)
S-62	361,000	1,030	720	323,000	206,000	56,000	(M)
204B	414,000	1,030	720	376,000	231,000	56,000	(M)
204B2	467,000	1,030	720	429,000	279,000	56,000	(M)
BO105	384,000	1,030	720	355,000	255,000	41,000	(S)
212	540,000	1,030	720	502,000	347,000	56,000	(M)
V107	688,000	1,030	720	637,000	397,000	64,000	(L)
214B	740,000	1,030	720	689,000	465,000	64,000	(L)
SA-360	421,000	1,030	720	384,000	287,000	56,000	(M)

Key: a: Model b: charter charge c: Passenger Fare
d: Adult e: Children f: Cargo Transportation Charge
g: Sojourn Charge h: Daytime i: night time
j: Size k: yen per hour l: Rotary Wing
S: Small Size m: yen per one night
M: Middle Size
L: Large Size

(Fares Approved On January 27, 1978 : Rotary-Wing Aircraft Division)
Cf. Rules for calculating fares and rents are shown in a separate table.

ORIGINAL PAGE IS
OF POOR QUALITY

In summary, helicopters have the following characteristics:

- (i) They cannot carry very heavy cargo (over 10 tons), at least for the time being.
- (ii) They cannot fly for long distances. Flight time of 1 hour or more is impossible at present.
- (iii) They do not need an airport and can fly even in very mountainous areas.
- (iv) Loading and unloading can be carried out safely and easily while the helicopters are hovering.
- (v) They can fly with sufficient safety against anticipated wind speed or sudden disorder of the air stream.
- (vi) They do not have any problem flying over even the highest mountains (3,000 m) in Japan.
- (vii) The operating costs and charter charges are very high.

The rest of this section will describe the **anticipated** problems which may be caused by future hybrid airships in **similar** operations.

First, (i) a hybrid airship is not an attractive prospect unless ^{/83} it can carry a load heavier than 10 tons using its buoyancy. Furthermore, (ii) it is desirable that such an airship carry certain kinds of loads directly onto ship decks, without using barges. Airships, however, are large in size and have poor maneuvering performance. Hence, (iii) some airport equipment for mooring the airships as well as take-off and landing grounds are necessary. It will be dangerous for airships to be operated in very mountainous areas. (iv) Loading and unloading will not be carried out as easily as by helicopters. Since the **cargoes** handled are heavier, crane-like means should be used rather than hoist means. It is difficult for airships to hover, and therefore, prevention of the load from swinging will be impossible of maneuvering the **airship bodies**. Thus, load-fixing means or load-capturing means will be necessary. Since the airships cannot safely stay in the air at very low altitudes, load-suspending ropes must be very long and rope-handling means will be very complicated. (v) It is not easy to keep the airships stable against anticipated wind speed or disorder of the air stream. In some cases, mooring of the airships themselves must be necessary. (vi) With higher design altitude, the liftable load must be lowered. Therefore, high altitude flight is not economical. In order to overcome the above-mentioned disadvantages and to attract a practical demand, the operating cost must be at least the same as, or preferably lower than, the cost of conventional truck transportation, including road and bridge reinforcement and repair expenses.

But, what will the cost be if a large-size helicopter is developed in Japan? The model BK-117, whose development is now being planned by Kawasaki Heavy Industry, will have a fully loaded weight of 2.7 tons. This development is estimated to cost about 10 billion yen. Based on

this data, it is estimated that the development cost of a 10-ton payload, 25-ton fully loaded weight helicopter will cost more than 50 billion yen.

III-3. Current State of Short-Distance Aviation and Passenger Transportation and Problems at Issue.

As one of the potential uses of hybrid LTA's, one can point to passenger transportation. Of course, due to their low cruising speed, hybrid LTA's cannot compete with other transportation means in long-distance air transportation. Therefore, one possible application of hybrid LTA's can be found in short-distance air transportation. Short-distance air transportation, however, has many problems at present. The short-distance transportation sector is the least profitable among air transportation sectors and the service ~~has~~ become inferior in quality. In the following sections, problems in short-distance air transportation will be described together with specific conditions which are required of short-distance air service. As an illustrative example of short-distance air transportation, the problems and issues related to short-distance air services in the environs of large cities will also be discussed. The last part of this section is a discussion of the problems involved in transportation to isolated islands.

III-3-1. Problems at Issue in Short-Distance Air Transportation and Materials Which Are Being Sought.

At present, about 15 % of the world's air transportation (passengers x transportation-distance) is done by lines with distance less than 500 km. Of course, these include those short-distance lines which are part of long-distance trips, such as the Osaka-Tokyo line which must be used as part of the trip from Osaka to the U.S.A. This means that, although air transportation is most advantageous for long-distance trips, short-distance air transportation means are also very important, and actually compete with ground transportation means. Short-distance air transportation, however, has many serious problems at present. The improvement of the service quality of short-distance air transportation is one of the most important tasks in future air transportation. /84

(a) Problems in Short-Distance Air Transportation.

The biggest problem in short-distance air transportation lies in its profitability. Most of the present short-distance lines are the so-called local lines. These have less demand than middle-distance main lines. On the other hand, short-distance air transportation must compete with many other ground means such as railroads, buses and private vehicles. Hence, in order to survive competition and to provide better service to passengers, more frequent flights must be scheduled. Thus, for these short-distance lines, small-size aircraft must be used to transport passengers with great frequency. As shown in Fig. III-25, however, the unit operating cost (the cost per passenger per km) rapidly becomes higher as the line distance becomes shorter. Thus, the operation of smaller sized airplanes is more costly. This is due to the

fixed costs, such as the airport take-off and landing fee, which are independent of flight distance. In addition, the 500-passenger Boeing 747 can be operated by three crew members (two pilots and one mechanic), while the 60-passenger YS-11 needs two crew members. Thus, the transportation cost includes fixed costs which are independent of the number of passengers carried by an airplane. Therefore, short-distance transportation means with small capacity are very disadvantageous.

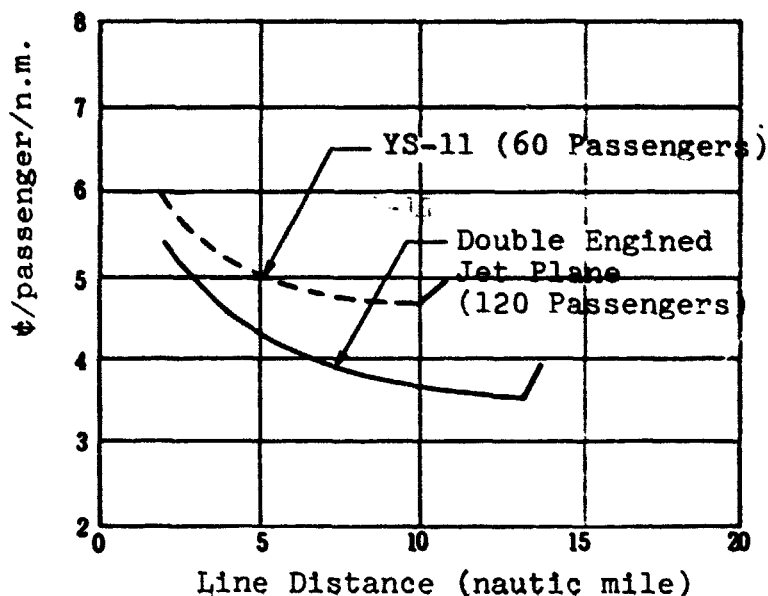

Fig. III-25. Comparison of Direct Operating Cost.

On the other hand, the revenue corresponding to the cost, that is the fare, has an unfavorable condition. Due to the short line distance, the benefit of high speed cannot be fully utilized in competition with other ground transportation means such as railroads, buses and private vehicles. In order to survive this competition, as low a fare as possible is necessary; thus the air transportation fare is kept very low in many cases. In relatively undeveloped areas, short-distance air transportation means are mildly competitive due to delayed development in road and railroad networks. However, in many cases, air transportation is a unique means of transportation and the fare is kept low. In each case, the air fare is not determined by the cost, but is kept low for other reasons. Inevitably, the profitability of the operation is very low. The extraordinarily low profitability forced by public policy is generally compensated by the government, as in the case of small-size airplane operations like South-East Airline and Japan Short-Distance Aviation in Japan and certain local lines in the U.S.A. In such cases, however, cost reduction or revenue maximizing efforts by the enterprises are not directly connected with improvement of the profit factor. In many cases, business efforts are discouraged and the

enterprises themselves tend to be unattractive. Under such conditions, the financial margin is generally very narrow and the enterprises lack the ability to make capital investment such as the introduction of new airplane models. There is no hope for drastic improvement in profits by any new model of aircraft with a low operating cost. Consequently, in such an **airline** old models cannot be replaced by new jet airplanes, and sometimes, old propeller or turboprop engine airplanes are used past legally determined lifetimes. Even to short-distance airlines, turbofan jet planes are very attractive in terms of their efficiency (unit transportation cost per hour) and their **public** appeal. In many short-distance airlines, however, an improvement in profits cannot be hoped for by the introduction of new turbofan jet planes. Such a new investment will probably directly result in management difficulty. Basically, low demand cannot support an operation of airplanes with more than 100 seats. At any rate, the introduction of jet planes to short-distance lines is practically impossible.

Another factor which makes the introduction of jet planes difficult is that of airport problems. In many cases, short-distance local lines provide air service mainly to **relatively underdeveloped areas**. Therefore, many airports used by such airlines are in generally poor condition. Usually, the runway is short and the airport is not equipped with advanced facilities, such as automatic landing means or airplane guidance means. Jet planes in particular require much longer runways than propeller planes. Geographical conditions do not permit long runways and make it difficult to find an appropriate plane, in many places. A typical illustration is the problem of a substitute airplane for the YS-11 in Japan. Air transportation in Japan has been increased at a rate of 20 % a year or more. But, with the exception of the airports for main lines and several main airports for local lines, airport equipment has not been improved in proportion to this growth. In addition, the development of airport equipment, including runways, have been delayed by pollution problems and the public reaction against the Japan Island Innovation Plan, that is, reaction against an excessively rapid pace of regional development. These issues will be dealt with later in greater detail. The YS-11 was developed for local airports with 1,200-m runways. However, some of the YS-11 airplanes have been used for over ten years. Since the efficiency of the YS-11 is only about one third of that of the Boeing 737 and the Douglas DC-9, which are a size larger than the YS-11, it has recently been proposed to replace the YS-11 by an appropriate jet plane for popular local lines, such as the Osaka-Tokushima or Osaka-Takamatsu lines. The past introduction of jet planes into Japan caused a remarkable increase in demand for many lines. Such an increase in demand was induced by the comfortable service and the mass transportation which were made possible by jet planes. Thus, the replacement of the YS-11 has been a matter of great interest to the airline companies. However, no jet plane is equipped with the ability to use 1,200-m runways, with high economical efficiency at the same time. Consequently, the airline companies have continued to use the YS-11 against their will.

Recently, as common problems of air transportation, environmental problems, particularly that of noise, have been seriously discussed. Particularly, the number of airplanes using airports within the environs of large cities have increased rapidly. Most airplanes using these

airports now are jet planes. In addition, with the enlargement of the city environs, the residences around airports have increased in number. Consequently, the airplane noise problem has recently been drawing attention as a kind of pollution. Several efforts to solve this problem are underway at present. These efforts include noise reduction of airplanes themselves, restriction of the number of airplanes which take-off and land at the airport, other restrictions such as time limitation, and removal of the airports to less populated areas. The last plan was also discussed in connection with airport enlargement. The environmental problem represented by noise is one of the most serious problems that every airline company faces at present. Short-distance airlines are not exempt from environmental problems. A short-distance airline, however, cannot use an airport which is far from the center of a city. For example, when travelling from Nagoya to Tokyo by air, if the flight time to Narita is 50 minutes and it takes two hours to go from Narita to Tokyo, it makes no sense to take an airplane. For this reason, a short-distance airline must use an airport which is close to the thickly populated center of the city for the convenience of its passengers. In this respect, short-distance airlines are facing tougher problems than middle- and long-distance airlines.

(b) Airplanes Which Are Being Sought and Overview of Future Conditions.

At present, turboprop airplanes are mostly used by short-distance airlines in Japan. Of course, even among short-distance airlines, many jet planes such as Boeing 737 and Douglas DC-3 are being used. The airlines using these jet planes have sufficient demand to support the operation of jet planes and have airports large enough for them. Therefore, such airlines have little problem in enlarging airline capacity in response to demand increase, for example, by replacing those jet planes by a size larger Boeing 727 or the like. In other words, they have no problems in obtaining suitable airplanes.

Turboprop airplanes were introduced into many airlines around 1960. In 1975, about 1,100 turbo prop planes, including about 700 YS-11 class short-distance turboprop planes, were used in various airlines in the world. These airplanes are used mainly in short-distance airlines which have the above-mentioned problems. Airplanes by which those turboprop planes can be replaced are now thus being sought by various short- /87 distance airlines. The geographical distribution of those turboprop airplanes is as follows: 23 % in Northern America, 17 % in Europe, and 6 % in Japan and the remaining 54 % in developing countries. Since the number of developing countries is less than 20 % in terms of geographical distribution of passenger transportation or in jet planes, it is understandable that the turboprop planes have a very important role in those developing countries. At any rate, by analyzing the present condition of the operation of these turboprop planes and by clarifying its characteristics, the type of airplane which is being sought by short-distance airlines will become clearer.

First of all, in what kind of airlines are turboprops used ? Figs. III-26 and III-27 show the relationship between the distance of the airline which uses turboprop planes and the length of the runway which those planes use. According to Fig. III-26, the average distance of airlines in which turboprop planes are used is about 300 km and 80 %

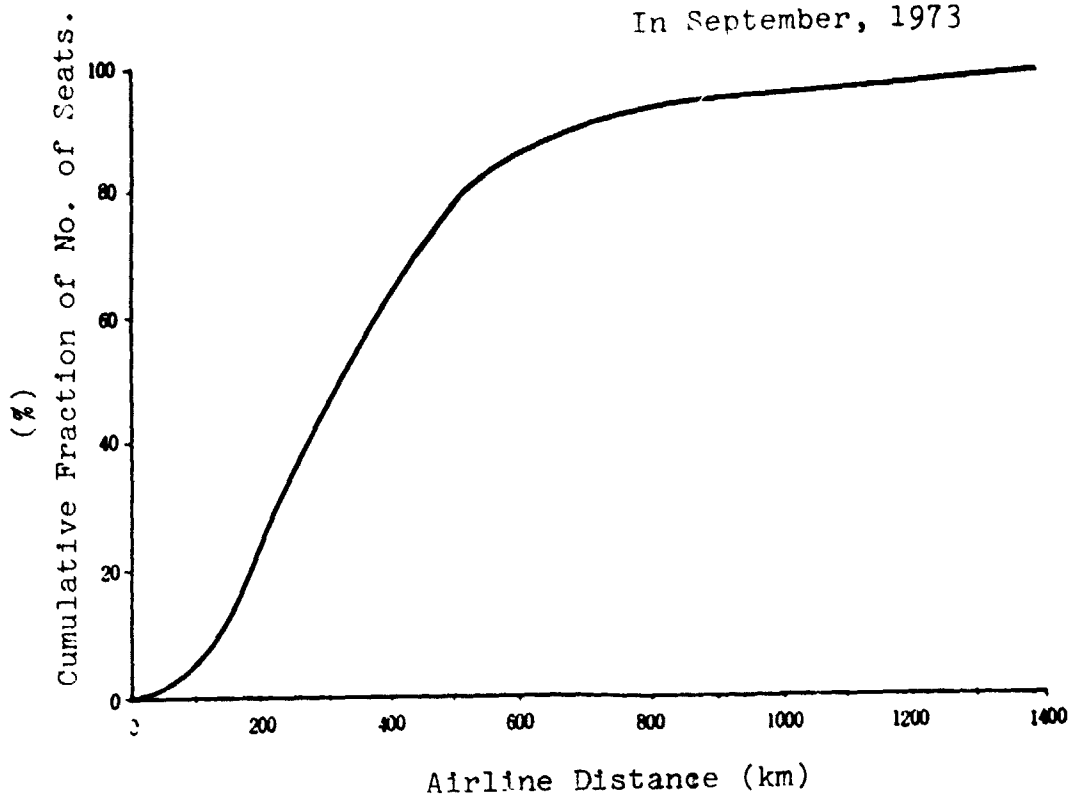

Fig. III-26. Cumulative Distribution Showing the Relation Between Airline Distance and Passenger Seats in Airlines Using Turboprop Planes.

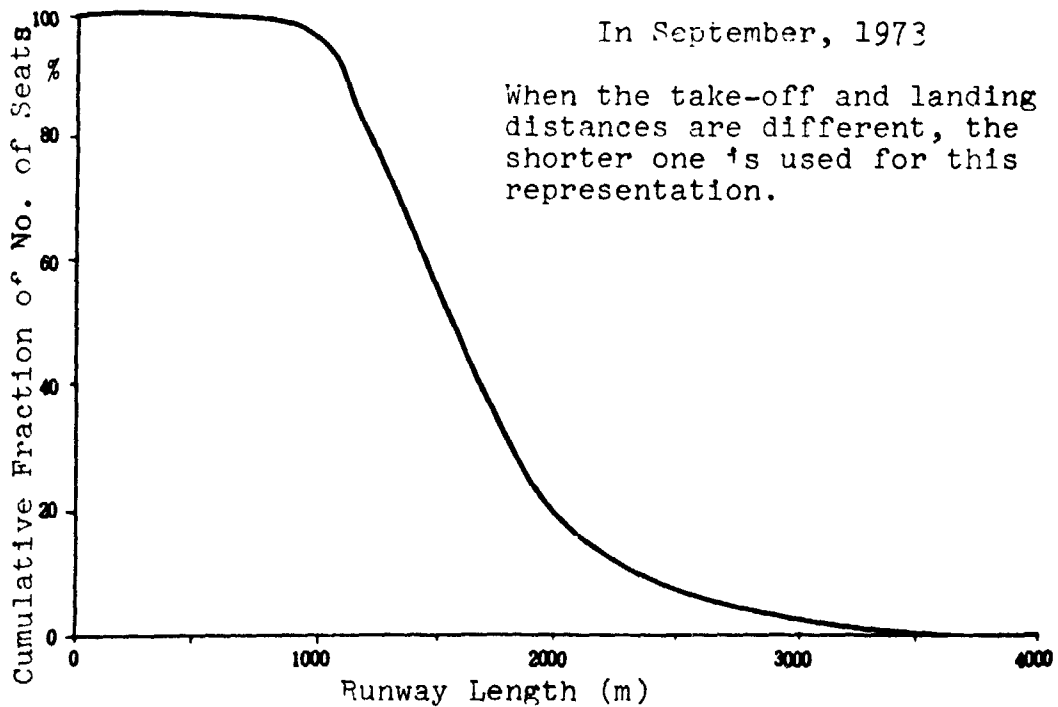

Fig. III-27. Cumulative Distribution Showing Relationship Between the Runway Length Used by Turboprop Planes and Passengers Carried by Them.

of the seat-km (the number of seats multiplied by the flight distance in km) is provided in airplanes shorter than 500 km. On the other hand, the average length of the runways which the turboprop planes use is 1,500 m, while 20 % of the turboprop planes must use runways of 1,200 m in length or less. This data suggests that the performance of the airplanes desired is characterized by take-off and landing ability rather than cruising speed. Namely, airplanes with excellent STOL ability are being sought at present.

Normal operation of conventional jet planes of the Douglas DC-9 or the Boeing 737 class requires a runway length of about 1,500 m or longer. As shown in Fig. III-27, these jet planes can be used by only 50 % of the airlines which are now using turboprop planes, solely for the reason of take-off and landing performance. /88

As mentioned previously, the most serious problem of short-distance airlines is profitability. Therefore, these short-distance airlines are seeking highly economical airplanes. In order to evaluate how economical an airplane is, direct operating cost is usually used. By direct operating cost, is denoted the cost which is mainly determined by airplane performance, that is, the cost which includes the cost of crew members (pilot, etc), fuel and lubricating oil, maintenance, insurance, and depreciation of equipment. Fig. III-28 shows this direct operating cost which is calculated according to the formula used to estimate operating cost by the domestic airlines in the U.S.A.

According to this, the direct operating cost of a turboprop plane is lower by about 15 % than that of jet planes with the same scale. The direct operating cost of the 60-seat YS-11 is 20 % higher than that of the jetplanes with twice as many seats, such as the Boeing 737 or the Douglas DC-9. This is due to the fact that the unit cost per seat can be reduced by using larger airplanes. In other words, even if the number of seats is doubled, the number of necessary crew members remains almost the same. The main motive for replacing turboprop planes such as the YS-11 by jet planes such as the Boeing 737 or the Douglas DC-9 is this reduction of direct operating cost rather than passenger comfort. When future demand is estimated to be able to support the increase in seat numbers and the runway is long enough for jet planes, there is little problem in introducing these jet planes, and higher profits will be obtained. However, if future demand is insufficient, or if the runway is not enough, the introduction of jet planes is very difficult. If the introduction of jet planes is forced despite the above difficulties, the cost will increase by 15 % and a breakdown of management will result. Since the difficulty of managing short-distance airlines resides in the circumstances described above, the desired type of airplane must ensure a direct operating cost which is at least less than that of the currently used turboprop planes such as the YS-11. If possible, an airplane which is as economical as a 120-seat class jet plane (such as Boeing 737 or Douglas DC-9) is desirable, namely, an airplane with 20 % lower operating cost than turboprop planes. /89

In addition, as mentioned previously, airlines managing short-distance transportation are less able to make capital investment due to their weak financial bases. Therefore, in many cases, even if there exists a model of airplane which meets the future demand and

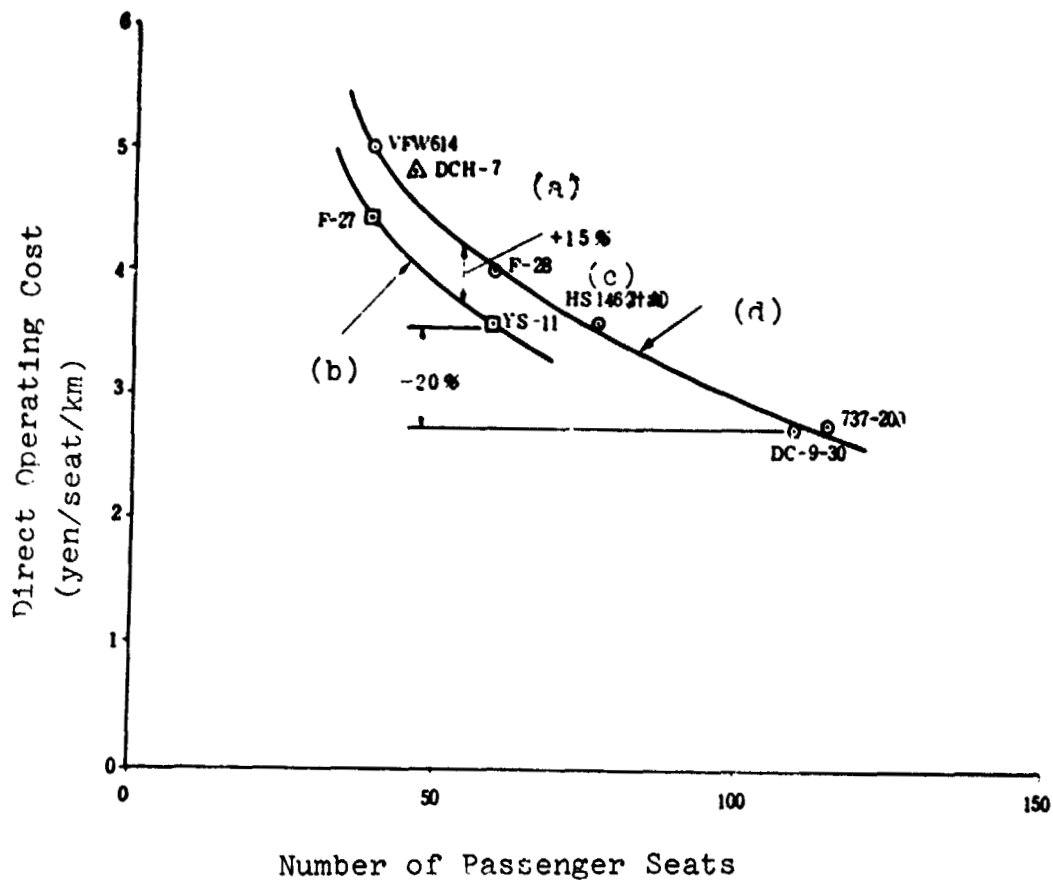

Fig. III-28. Comparison of Direct Operating Costs Between Turboprop and Jet Planes.

Key:

- (a) STOL Turboprop Plane
- (b) Turboprop Planes
- (c) Planned
- (d) Jet Planes

Remarks: The figure was made based on the data of the U.S. domestic airlines in 1972. The cost is calculated for a 550-km line operation.

ORIGINAL PAGE IS
OF POOR QUALITY

promises greater profit, such an airplane cannot be purchased and operated for financial reasons. In fact, more than 400 old propeller planes (a half of which are DC-3) are still operated in the world at present. This fact indicates that there are many airplane operators who are unable to make capital investment and cannot afford to purchase even turboprop planes. If, as a goal, an airplane is produced for this market of short-distance air transportation, low cost has the first priority. A low price can also reduce the depreciation cost which occupies 15 to 20 % of the direct operating cost and is therefore suitable for short-distance airlines which have little purchasing ability. /90

As a replacement for the currently used 40 to 60-seat turboprop planes, the capacity of the airplane must correspond to the demand. A 80 to 120-seat airplane will be appropriate, considering the future increase in demand. In Japan, the currently used YS-11 has 60 seats and the growth in passenger demand there is greater than the world average. Therefore, an airplane with slightly larger capacity, namely, a 120 to 150-seat airplane is desirable for short-distance airlines in Japan.

In summary, the following conditions are required of an airplane which is intended for use as a means of short-distance air transportation:

- Economical -

The airplane must be at least as economical as the currently used turboprop planes. 20% improvement is desired.

- Capacity Corresponding to Demand -

The desired capacity is 80 to 120 seats per plane, when the future demand increase is considered. In Japan, slightly larger capacity is preferable.

- Excellent Take-Off and Landing Performance -

The airplane must be able to use an airport with a 1,200-m runway and an incomplete flight guidance system.

The future demand for airplanes which satisfy the above conditions is described below:

As previously mentioned, there are about one thousand turboprop airplanes used in short-distance airlines at present. In these airlines, the currently used turboprop planes cannot be replaced by jet planes such as the Boeing 737 or the Douglas DC-9 because the runways are too short or because the passenger demand is too low. From the passenger's point of view, the turboprop plane service, which has the same air fare system, is not attractive when the factors of speed and comfort in the airplanes are taken into consideration. From the airlines' viewpoint, it is not desirable to operate airplanes whose ages are reaching their limit and which are not economical. Hence, as soon as circumstances permit, their replacement by jet planes is desired

by the airlines. Therefore, in about half the airlines using airports with sufficiently long runways, turboprop planes will gradually be replaced by conventional jet planes or improved models of them in the near future. Therefore, the remaining 50 % of the market will be open to some type of airplane which will be developed. Within this fraction of the market, about 300 turboprop planes are used in lines shorter than 300 km. The replacement of these planes may be said to constitute a likely market for hybrid LTA's which have excellent STOL ability. This market will grow as passengers increase in number. If the number of passengers doubles in ten years (with about 7 % growth rate), the demand in this market is estimated to correspond to about 600 turboprop planes. Moreover, if LTA aircraft have twice as many seats as the turboprop planes or slightly more, the scale of this market will be 200 to 300 LTA's. /9

This market, however, has basically low passenger demand, and hence, whatever model of aircraft is introduced, a significant improvement in profitability cannot be expected. In particular, in order to maintain the airlines with poor profits, some economic policies are essential, such as joint sale with other popular lines, financial aid or special fare. Without the aid of these special economic policies, the profit seeking enterprises operating these airlines will lose interest in continuing operation. Consequently, the effort to improve air transportation services will vanish and the market will be reduced in size. Thus, the future of these markets is largely dependent on whether or not the passengers, the local communities or the government will acknowledge the necessity of local airline services, and whether or not each group of people are prepared to bear the increased cost or public financial aid.

On the other hand, what model of airplane should be used for the replacement of the turboprop plane is the problem under discussion in Japan at the present. In short-distance airlines using YS-11, especially the airlines connecting airports with 1,200-m runways in isolated islands, a replacement will be enthusiastically sought in the near future. At present, the third five-year plan for improving airports has been in effect since 1976 and many airports in Japan will soon have completed the improvement of their equipment. However, even if all the plans have been carried out by the end of this plan, many airports, especially those in isolated islands, still have only 1,200-m runways. On the other hand, the YS-11 planes currently in use have been operated for 6 to 12 years, and hence, they must give way to another model of airplane since the YS-11 is no longer being produced. At present, about 70 YS-11 planes are being operated in the private transportation sector. Although some of them will be replaced by jet planes according to passenger demand increase and improvement of airport equipment, about 20 to 30 planes will have to be replaced by another type of aircraft which has a larger capacity (120 to 150 passenger seats class) and can be operated with 1,200-m runways. However, as mentioned in the previous descriptions in which these problems are discussed in general terms, as world problems, similarly in Japan, whether the air transportation services with low profitability can be continued by introducing new types of planes or not, is strictly dependent on the decisions made by local communities and the government. Hence, the demand for a new type of aircraft is very much dependent on

the government's policy on transportation problems in Japan.

III-3-2. Short-Distance Air Transportation in the Environs of Large-Cities.

Short-distance air transportation in the environs of large-cities has developed along with the enlargement of the areas caused by the growing city zones, the congestion of ground transportation means caused by the centralization of city functions, and others. Along with city expansion and increase in the air transportation, the relocation of many main airports in places which are remote from city centers is now being planned. A new demand for transportation between the remote main airport and the central area of the city, or between new and old airports, has been thus introduced into the realm of short-distance air transportation. In one case, the main airport of a large city has recently been moved to a place which is very far from the center of that city, and consequently it takes longer to go from that airport to the center of the city than it takes to fly from that airport to another airport. In order to solve this problem, a new attempt is now being made to use VTOL or STOL airplanes as transportation between such an airport and the center of the city. The operation of New York Airways Company in New York City is an example of the former (VTOL), and the operation by Air Transit Company in Canada is an example of the latter (STOL). In the following, these two examples will be described in order to illustrate the present state of short-distance air transportation in the environs of large-cities. /92

(a) Operation by New York Airways Company.

New York Airways was established in 1949 and started passenger transportation in the environs of New York City in 1953. Afterwards, the company began air transportation service connecting Kennedy International Airport, LaGuardia Airport and Newark Airport, with financial assistance from New York City and major U.S. airlines, Pan American, TWA and others. Since 1971, the company has used Sikorsky S-61 heli-

Table III-12. Operation by New York Airways.

Line	Distance	No of Flights	Operating Hours	Flight Time	Fare
Kennedy Airport - La Guardia Airport	18	20	6:30 - 21:30	5	23.15
Kennedy Airport - Newark Airport	34	23	6:30 - 22:00	10	29.63
La Guardia Airport - Newark Airport	30	23	7:00 - 21:00	8	29.63
Pan Am Building - Kennedy Airport	20	37	8:00 - 21:00	7	23.15
Pan Am Building - Newark Airport	16	19	8:00 - 21:00	5	23.15
Pan Am Building - La Guardia Airport	13 km	26 per day	8:00 - 21:00	5 minutes	17.36 dollars

Remark to Table III-12: The competing ground transportation means are taxis, buses, limousine services and others, in each of the lines.

copters to provide transportation between the above three airports and the Pan Am Building in the center of the city. (See Table III-12 for the condition of each line.) However, company's financial condition has not been good. In 1976, the revenue was 6.8 million dollars while the expenditure was 7.48 million dollars - a loss of about 10 %. The reason given is as follows: Although about 550 thousand passengers use the service, the seat occupancy rate is as low as around 35 %. Furthermore, 99 % of the passengers use the service to connect with domestic and international long-distance airlines. According to the contract with the airline companies, these passengers receive a fare discount. Consequently, the revenue of the company has been suppressed. An effort was made to balance the revenue with the cost by reducing the operating cost while using four 30-passenger S-61 helicopters. Unfortunately, the operating methods used for decreasing the operating cost, in which helicopters do not stop the rotors while loading or unloading passengers, resulted in an accident on the roof of the Pan Am Building last year. At present, transportation from the Pan Am Building is not in operation. The New York Airways Company's operation is a typical example of the fact that short-distance airlines cannot easily be profitable. However, this case will be an important object of study in connection with the problems in the environs of large-cities, especially, the question, what is the efficient means of connecting airports and city centers, when the distance between the center of the city and the airport is becoming longer, as a general prevailing tendency.

(b) Operation by Air Transit Company.

As a general trend, the distance between the center of a city and its airport is becoming longer both temporally (due to traffic congestion) and geographically (due to environmental problems). The operation by the Air Transit Company is being experimentally supported by the Canadian government in order to research new transportation means which are capable of matching different requirements by different groups of people, i.e., passengers, residents around the airport and airline companies. Air Transit Company was established as a subsidiary company of Air Canada which is 100 % financed by the Canadian government. This company operates an experimental line (180 km) between Ottawa, the capital, and Montreal, the center of business. For this operation, not the regular airports but newly constructed airports are used. These new airports are exclusively for STOL airplane, the 11-passenger Dehaviland DHC-6, which connects the two airports and provides a shuttle service (about 30 rounds a day). Each of these new airports was constructed in a city area not far from the center of the city. (about ten minutes by car.) The financial condition has not been made public. However, since the seats in the DHC-6 are halved for experimental reasons and the company bears extraordinary costs such as public display or demonstration costs, a large deficit is probably being recorded. (According to one source, the deficit is almost 50 % of the revenue.) Nevertheless, the Canadian government evaluated the three-year experimental operation as follows:

(1) The necessity of air transportation was proved even in a short-distance transportation situation in which competition is intense. (There are two railroad lines, one-hour-frequency rapid bus service and private vehicles.) According to the estimate by the Canadian government, the share of the air transportation among all the transportation means connecting the two cities has been improved from 3.3 % to 5.4 %, owing to the operation of this STOL transportation service.

(2) By not using the existing airport for the existing airlines and by constructing new airports especially for STOL planes, high efficiency was achieved without interfering with other air transportation operations. /94

(3) Although the newly built airports are located in city areas, the majority of their residents are in favor of this STOL plane operation. This transportation system was thus proved to have created no serious environmental problem.

(4) However, the service is very costly. To solve the problem of this high cost is a future goal.

Based on these evaluations, the experimental operation is still going on. There is a plan to experimentally operate a plane, one size larger, the 50-passenger Dehaviland DCH-7, in the future. Profitability is expected to be improved by this new operation. Thus, STOL plane transportation is still in the experimental stages. However, it promises the possibility of providing innovative transportation means in the future. The operation of Air Transit Company is actually promoting the development of this new system and is certainly valuable.

The performance of DCH-6 and DCH-7 is described in the following (Table III-13):

Table III-13.

	DCH - 6	DCH - 7
No. of Seats	20	54
Cruising Speed	290 - 230 km/h	434 km/h
Endurance Flight Distance	1,280 km	1,200 km (PL: 12.2 t)*
Required Runway Length	ca. 600 m	ca. 770 m
Maximum Load	5.7 ton	19.7 ton
Engines	650 HP x 2	1,174 HP x 2
Crew Member	2	2
Price	2.7 billion yen	ca. 10 billion yen
Remarks	4 units are in Japan. (South-West Airlines, etc.)	Used in actual operation, now. Not used yet in Japan.

* 2,700 km with 6.6-ton payload.

III-3-3. Current State of Transport to Isolated Islands and Problems at Issue.

Japan consists of approximately 5,000 islands, including four main islands, Honshū, Kyūshū, Hokkaido and Shikoku, which together are the so-called "mainland." The islands other than these four may be called "isolated islands." Among the isolated islands, Sado Island is the largest. The number of the inhabited islands is around 420. According to the Act for the Development of Isolated Islands which is effective for ten years, the estimated number of isolated islands is 722. Each of these isolated islands is in a unique natural condition which is different from others. These islands are classified into four types, isolated type, group type, adjacent type and inland type. Within one type, the islands are further classified into sub-categories according to their size, master-dependent relationship, etc. Naturally, the problems involving each island vary greatly depending on individual natural conditions. The most serious problems may be said to be those involving the isolated type of islands. By isolated islands, is meant islands with a population of 5,000 or less and separated from the nearest island one hour or more by a ship with a speed of 10 nautical miles per hour or more. The majority of the isolated islands of this type, however, have populations of 1,000 or less. The 722 islands which are denoted "isolated islands" by the previously mentioned Act have an area of 6,750 km² in total and occupy 1.8 % of the total land area of Japan. The population in these islands is about 1.04 million (1970) and about 1.0 % of the total population /95 of Japan.

The most serious problem for the people living in the e islands is the lack of medical facilities. Recently it has become difficult to maintain sufficient medical service in some places even on the "mainland." The gravity of such a problem on the isolated islands is an obvious threat to daily life. On the main islands, although it might take a certain amount of time, one may expect ambulance service, or at least, that a medical doctor be sent to the patient. Transportation to the isolated islands, however, is prohibited by rough seas, and no ambulance service is available. In many cases, the island does not even have a heliport or a helicopter route leading to it, and hence, patients sometimes die without any medical treatment.

The second problem of the isolated islands is that of transportation. Since those islands are thinly populated, they themselves do not have sufficient economical means to support, or invest in, a transportation system.

The third problem is product distribution. People in those isolated islands must purchase products at so-called "isolated-islands-prices" which are substantially higher than those on the "mainland." In addition, the products in those isolated islands, such as fish products, suffer from unfair competition, since those products have lost their freshness in the market due to the lack of adequate means of transportation.

These problems of isolated islands were investigated by the Japanese government in 1972. In the next year, 1973, based on a series of land development plans in Japan - Japan Island Innovation Plan, New National General Development Plan, etc. - which were promoted by the cabinet headed by Prime Minister Tanaka at that time, it was decided that transportation networks be arranged so that every isolated or remote place might be reached from the regional center within two hours. Based on these plans, a 150-passenger Hovercraft was trial built and used for the Marine Exposition in 1975.

However, the present condition is such that many islands can hardly insure a daily ship communication schedule. Even for the relatively well-known Seven Izu Islands, only a weekly stop of a ship is available, with the exception of Ohshima and Miake Islands. In the case of isolated islands, there is no source of financing and no sufficient transportation demand to support the operation of any transportation means. Even if some transportation means are established, the cost of building and operating ships inevitably causes a large deficit. Therefore, at present, the government assesses the deficit of such a transportation system and compensates 75 % of the assessed amount of loss.

In the following, the **problems in the use of Hovercraft**, introduced in an attempt to speed up the lines connecting isolated islands, will be described:

If a line has the conditions necessary for the use of Hovercraft, namely about 18,000 passengers per month and about 220,000 passengers per year, one can say that the line is in relatively good condition. The lines satisfying the above-mentioned conditions must be around 125 km long and be able to insure an annual average utilization of 70 % be a **two-round-a-day** operation with an operating percentage of 75 %. Fig. III-29 shows the total transportation of the representative lines connecting isolated islands. One can see from the figure that about 10 lines in Japan have this condition. Even if a line satisfies this condition, it is very difficult to operate the Hovercraft with a higher frequency than two rounds per day. Only a few lines can afford 2.5 rounds per day. Usually, Hovercraft must share the passenger demand with other means such as a ferry or a passenger ship, and hence, the operation of Hovercraft is restricted, even when the line has sufficient passenger demand.

Fig. III-29. Total Transportation Between "Mainland" and "Isolated Islands"

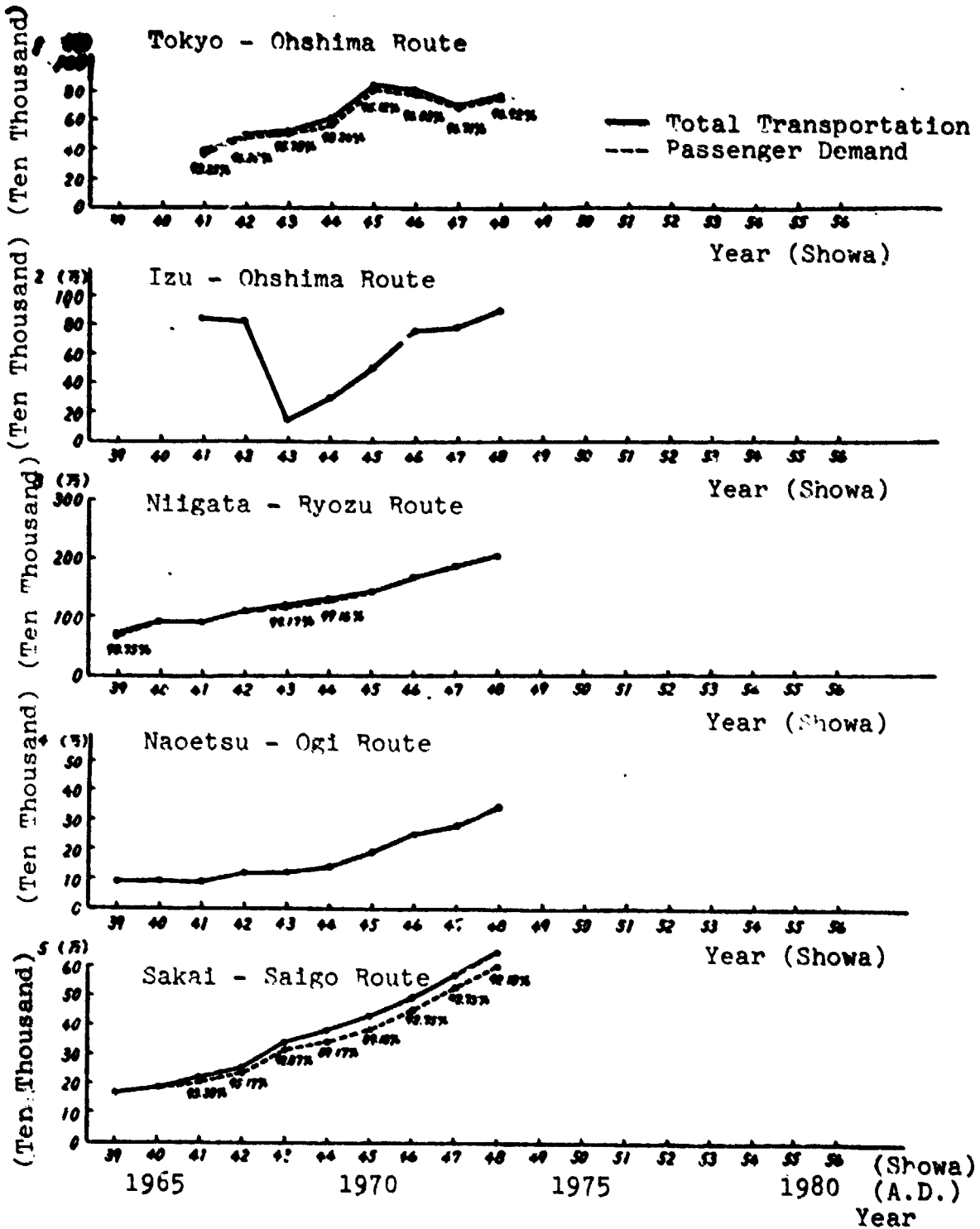

- continued -

ORIGINAL...
BEST COPY QUALITY

ORIGINAL PAGE IS
OF POOR QUALITY

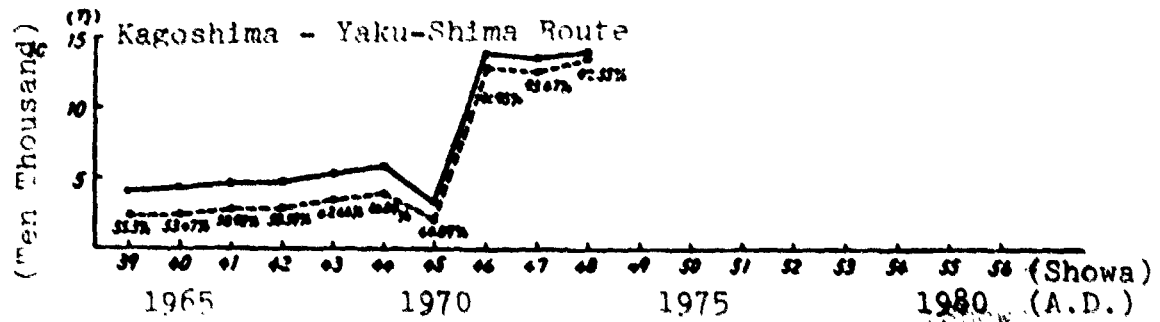
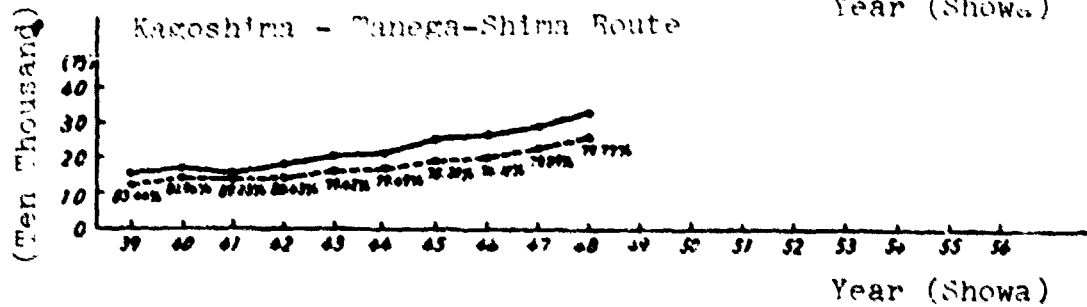
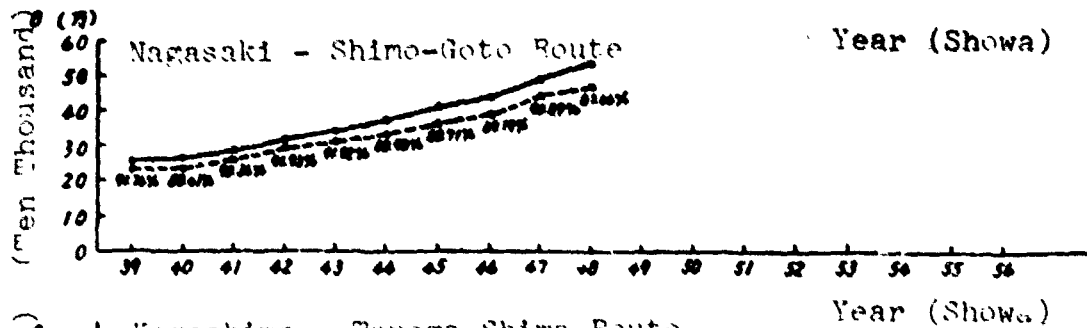
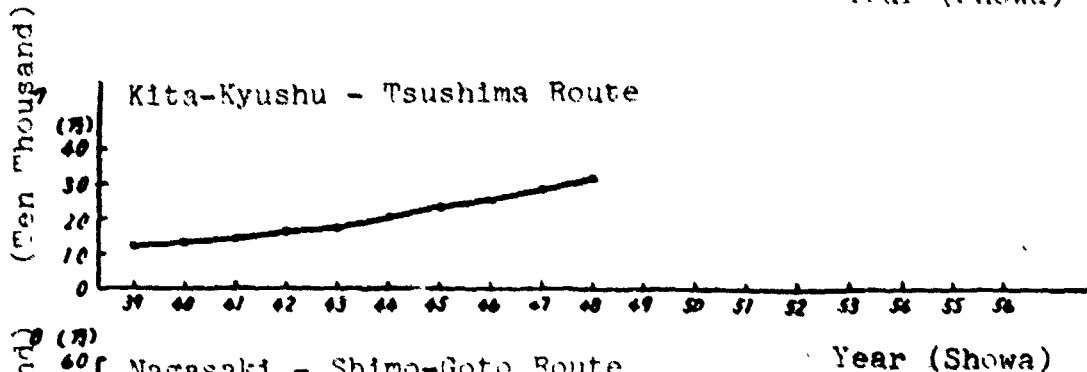
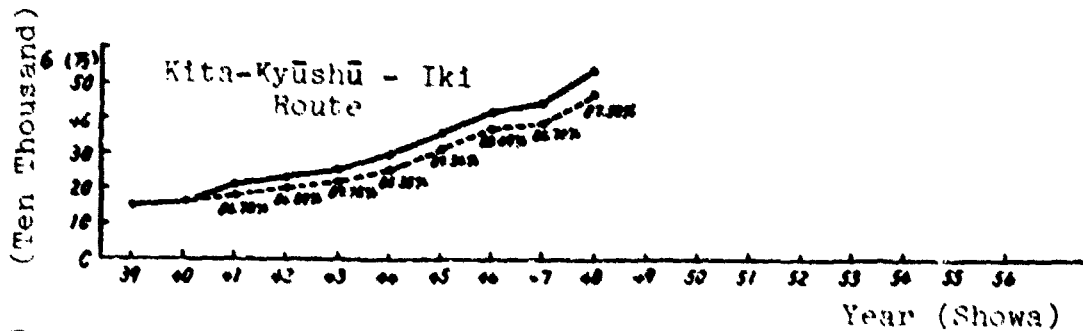

Cf. — Total Transportation
--- Passenger Demand

1970 A.D. = The 45-th Year of Showa

In the following, examples of actual operation of Hovercraft will be described: The **GEM (Ground Effect Machines)**, or the air cushion boats, which are generally called "Hovercraft" in Japan, were first developed for practical use in England in the 1950's. In Japan, Mitsubishi Heavy Industries imported a Hovercraft in 1967 from Westland Company in England and leased it to Kyushu Shosen Company. This Hovercraft was used on the Shimabara - Kumamoto line (a triangular route). The name of the model was SRN-6 and the capacity was 38 passengers. This operation failed since its profits were poor, due mainly to the fact that the Hovercraft was not known to the public. Thus, the operation was terminated about one year later. The same craft was leased to Shima Sightseeing Company in 1968 and used in a line connecting Shima and Katsuura in Mie Prefecture. This operation also failed and the craft was scrapped in 1969.

Mitsui Ship Building Company had been engaged in the design and manufacture of a Hovercraft during those years. In 1969, the company **succeeded** in building the first craft, a 55-passenger MV-PP5. This Hovercraft was used in a line connecting Toba, Mie Prefecture, and Gamagōri, Aichi Prefecture, for the first time. Since then, this model of Hovercraft was gradually sent into the mission in Ohita/Beppu - Ohita Airport Line, Kajiki - Kagoshima Line, Sakura-Jima - Ibusuki Line, Ishigaki-Jima - Yaye-Jima Line and Uno - Takamatsu Line. The company also built a middle-size Hovercraft, 155-passenger MV-PP15, and sent it to the mission in the "International Marine Exposition," which was held in Okinawa from July, 1975. Three Hovercraft of this model were used in a line (59 km on the sea) connecting the exposition ground (Expo Port on the tip of Honbe Peninsula) with Naha Airport. Table III-14 shows the present state of the Hovercraft in Japan. /98

Table III-14. Hovercraft in Japan.

Line	Operating Company	Model	Period	Remarks
Kumamoto - Shimabara	Kyushu Shosen Co., Ltd.	SNR-6	Sept., 67 to Sept., 68	1
Shima - Katsu'ura	Shima Sightseeing Ships Co., Ltd.	SNR-6	from Oct., 1968	2
Toba - Gamagori	Meitetsu Sea Sightseeong Co., Ltd.	MV-PP5	from 7/25/69	3
Ohita/Beppu - Airport	Ohita Hovercraft Co., Ltd.	MV-PP5	from 10/15/71	4
Kajiki - Kagoshima - Ibusuki	Airport Hover Co., Ltd.	MV-PP5	from 7/23/72	5
Ishigaki - Yayejima	Yayejima Sightseeing Ferry Co., Ltd.	MV-PP5	from 7/25/72	6
Uno - Takamatsu	Japanese National Railways	MV-PP5	from 11/18/72	7
Ohsaka - Tokushima	Japan Hover Lines, Co., Ltd.	MV-PP5	from 12/21/74	8
Expo Port - Naha	Ryukyu Sealines, Co., Ltd.	MV-PP15	from July, 1975 (planned)	9

Remarks to Table III-14.:

1. Leased from Mitsubishi. Terminated due to deficit.
2. Leased from Mitsubishi. Terminated in about a year, and scrapped afterwards.
3. Leased from Mitsui. 1 ship
4. Leased from Mitsui. 3 ships
5. Leased from Mitsui. 3 ships
6. Leased from Mitsui. 1 ship
7. Leased from Mitsui. 1 ship
8. Leased from Mitsui. 2 ships
9. Leased from Mitsui. 3 ships

In the following, individual cases of these Hovercraft lines will be described in more detail:

(a) Beppu/Ohita to Shin-Ohita Airport.

Beppu/Ohita - Shin-Ohita Airport Line was opened in October, 1971, when the former Ohita Airport was moved from its location in Ohita City to a new location. (The name was changed to Shin-Ohita Airport.) The route, the fare and the required time are shown in Fig. III-30, the required time being compared with other transportation means. Many of the construction works connected with the operation, such as construction of arrival and departure bases, were partially financed by Ohita Prefecture. 90 % of the investment for the line operation was financed by Ohita Prefecture, while the rest was financed by Nippon Yusen (Mailship) Company (44 %), Ohita Kōtsū (Transit) Company (45 %), and others (2 %). Thus the total capital contributed amounted to 260 million yen. In 1974, the company had three Hovercraft including one stand-by craft. These hovercraft are all the MV-PP5 model, have a gross tonnage of 22.80 tons, a capacity of 51 passengers, power of 1,050 HP and a speed of 45 knots. The purchase price was 560 million yen per three craft excluding equipment. The equipment cost and other costs amounted to 90 million yen. Thus, the initial cost was 650 million yen in total.

The actual passenger transportation was 133 thousand in 1972 (passenger utilization percentage: 30.8 %), 216 thousand passengers in 1973 and 258 thousand passengers in 1974 (passenger utilization percentage: 60.6 %). Passenger transportation has thus been growing. On the other hand, a high operating percentage, 89.8 % in 1972, 94.9 % and 95.6 % in 1974, has been maintained. In general, Hovercraft are sensitive to rough weather. However, this Ohita route (29 km and 24 minutes) is a coastal route (or semi inside-bay route) and relatively calm weather has kept the operating percentage at a high level. The route has its origin and destination at the airport, the center of the city. The operation has been able to make full use of the advantages of Hovercraft, namely, (1) the ability to arrive and depart on land (essentially requiring no harbor facility) and (2) the high speed which is

Fig. III-30. Ohita Hovercraft Route. (29 km)

Route

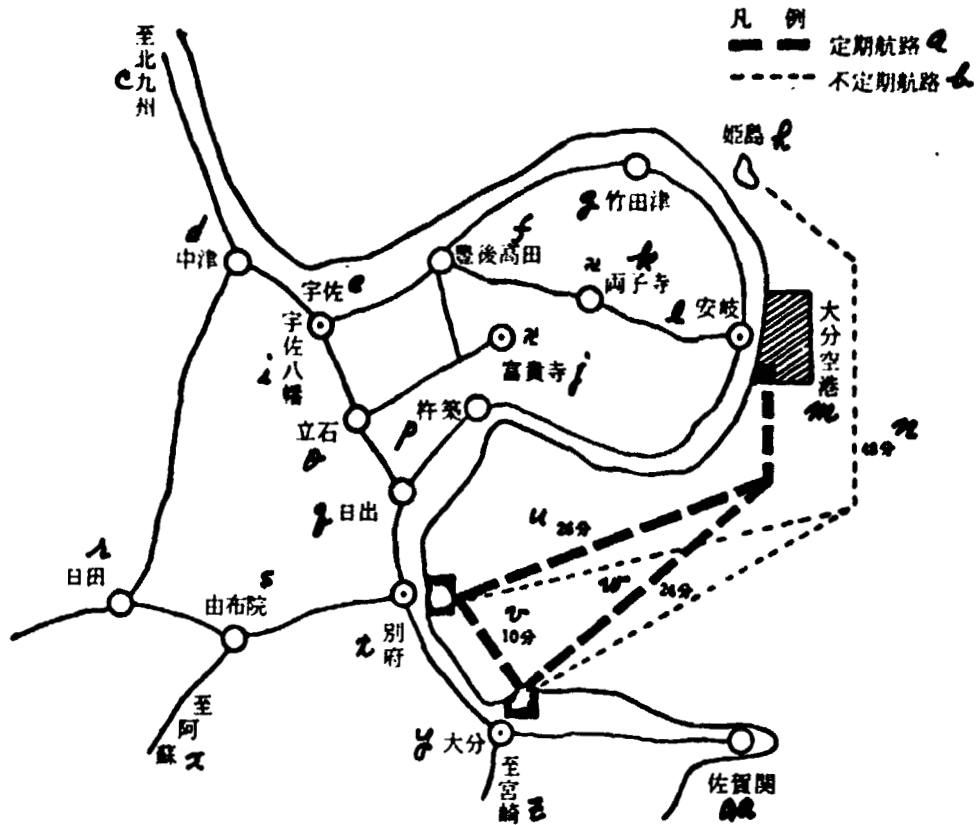

Key:

a: Regular Route
 d: Nakatsu
 h: Hime-Jima
 k: Ryōgo-Ji
 n: 48 minutes
 q: Hiide
 t: Beppu
 w: 24 minutes
 z: To Miyazaki

b: Special Route
 e: Usa
 i: Usa-Hachiman
 l: Aki
 o: Tateishi
 r: Hida
 u: 26 minutes
 x: To Aso
 aa: Saganoseki

c: To Kita-Kyūshū
 f: Hōgo-Takada
 j: Fūki-Ji
 m: Ohita Airport
 p: Kinuzuki
 s: Yūhu-In
 v: 10 minutes
 y: Ohita City
 g: Takedazu

- continued -

ORIGINAL PAGE IS
 OF POOR QUALITY

ORIGINAL PAGE IS
OF POOR QUALITY

Ticket



Required Time

	Ohita Airport - Beppu	Beppu - Ohita Airport
Hovercraft	26 min.	24 min.
Bus	55 min.	1 hour 25 min.
Taxi	50 min.	1 hour 10 min.

Cf. Distance: Ohita Airport - Beppu by Land
42 km

Ohita Airport - Ohita by Land
54 km

ORIGINAL PAGE IS
OF POOR QUALITY

Fare (Passenger)

		Ohita Airport	Port Division
	Ohita	1,300 yen 29 km	Fare Distance
Beppu	500 yen 12 km	1,300 yen 31 km	Fare Distance

available whenever natural conditions allow. The passengers using the Hovercraft constitute 30.3 % of the total passenger transportation (including bus, taxi and Hovercraft) between the city and the airport. The schedule has 13 rounds per day and is arranged to connect with the arriving and departing airplanes. This Ohita route of the Hovercraft marks the best management condition in Japan. The reasons are: (1) The prefecture offered a great amount of financial aid, (2) the competing operators offered economical back-up to the Hovercraft operating company, and (3) the Hovercraft is the minimum time transportation means connecting the city and the airport. However, the problem is that maintenance and repair operation is time-consuming and thus a sufficient number of stand-by craft is required. For example, the overhaul of parts takes a substantial amount of time: 2,250 hours (about three months) for an engine, 4,000 hours (20 days) for an engine gear and 1,500 hours for propeller. /100

(b) Kajiki to Kagoshima/Sakurajima to Ibusuki.

The Kajiki - Kagoshima/Sakurajima / Ibusuki Route was started when the present Kagoshima Airport was moved from its old location at Komanoike and new rapid transportation means to the new location of the airport were sought. The route is shown in Fig. III-31. The used model is MV-PP5. At present, three Hovercraft are being used. The Hovercraft stops at four ports. None of the four ports, however, is equipped with a Hovercraft slip way, making it impossible to exploit the advantage of the Hovercraft, namely, "the ability of on-the-ground loading and unloading of passengers." The fare of the Ibusuki route is about half as much as the taxi fare via the land route. However, since Kajiki is located at a place about 20 minutes from the airport by bus or taxi, about 50 % of the airplane passengers use bus service to Kagoshima. Only a fraction of passengers who use taxis take Hovercraft. Passenger transportation between Kajiki and Ibusuki was 46,308 passengers in 1973 (passenger transportation utilization percentage: 16 %). 70 to 80 % of the passengers are tourists. The boarding percentage was 20 % in 1973 and was 60 % in 1974. The business is in such poor condition that the operating cost is about 3.9 times higher than the revenue. The reasons are: (1) insufficient advertisement, (2) the lack of slip way, and (3) the increase in the operating cost which is suspected to be caused by the operating rules set by the Ministry of Transportation.

According to the present operating standards of Hovercraft, operation must be stopped if one of the following conditions is observed: the field of vision of 1,000 m, the wave height of 150 m and the wind speed of 18 m/sec. Although a Hovercraft is actually a ship, the operating standard set by the Ministry of Transportation is not clearly defined since it uses an aircraft engine. Operators of Hovercraft feels that the maintenance cost is lower if the Hovercraft are legally treated as aircraft. Due to the engine noise during the maintenance service, it is a disadvantage to locate the berth on the sea rather than on the ground.

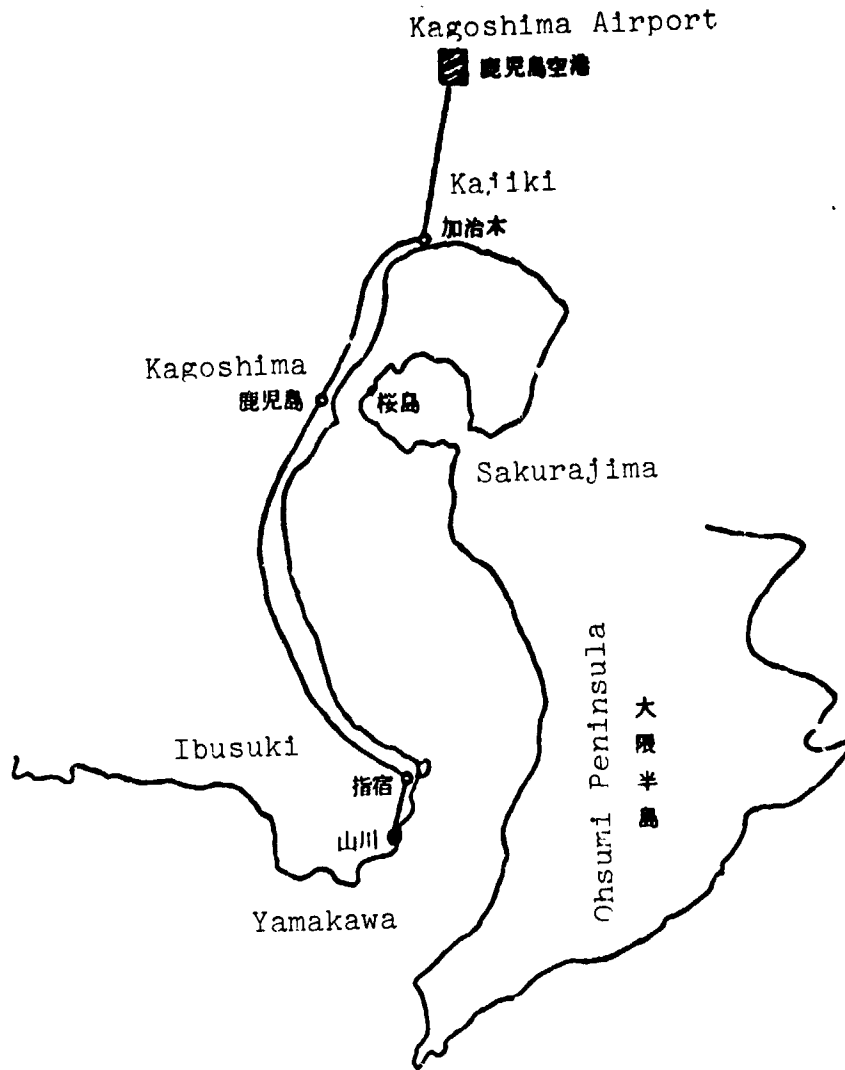

	Airport - Kajiki		Kajiki - Kagoshima		Kagoshima - Ibusuki		Kajiki - Ibusuki	
	Time (min)	Fare (yen)	Time (min)	Fare (yen)	Time (min)	Fare (yen)	Time (min)	Fare (yen)
Hovercraft			25	900	55	1,900	70	2,800
Taxi	17	1,000	40	2,500			120	12,000
Bus	20	120	60	400				
Railway			35	120	75	250		
Distance (By Sea)			18 km		43 km		60 km	
(By Land)								

Fig. III-31. Ibusuki Route.

ORIGINAL PAGE IS
OF POOR QUALITY

The Niigata - Sado line is about 70 km long. The majority of the 600 to 700 thousand passengers are summer tourists. With a target of one million passengers per year, a Jet-foil was introduced. Jet-foil is manufactured by the Boeing Company. At the time when it was introduced to this line, Jet-foil had been used only in Hawaii. Afterwards, however, Jet-foil was introduced to **the Hongkong - Maccao Line**. The one which was used in the Sado Line was the No. 8 or No. 9 machine. The purchase price was 2.8 billion yen. The introduction of Jet-foil by Sado Steamboat Company was financed 50 % by the Prefecture. Since the lease was very expensive (5 billion yen for ten years) at that time, the Jet-foil craft was purchased by a long-term loan. The jet-foil started its mission in May, 1977, and since then, the operation percentage has been almost 100 %. This proves that this craft can be operated in almost any weather condition. Actually, the craft can be operated in 3.5-m waves, without disturbing the comfort of the passengers. Comparison of the available transportation means in the line is as follows:

<u>Transportation means</u>	<u>Required Time</u>	<u>Fare</u>
Conventional Ship	2.5 hours	720 yen
Jet-foil	40 minutes	3,680 yen
Airplane	25 minutes	4,900 yen

Each time and fare in the above is from Niigata to Sato.

Since the start of the mission at May 1, 1977 until the end on January, 1978, the operating percentage was 95 % and the total number of the passengers was 243 thousand. The initial target of total passengers was 230 thousand. Hence, the operation was considered to be a success.

The most important reason for this success is the fact that this craft can be operated under almost all weather conditions. The conventional Hovercraft, on the other hand, cannot be operated on the open sea due to its sensitivity to high waves. According to the operating company, Sado Steamboat, the other reasons for the operation's success are these: First, the noise during navigation is very low. Secondly, since the ship is not a "sunken-bottom" type, but a "semi-floating-bottom" type, the water spray does not reach the windows so the passengers can fully enjoy the window view.

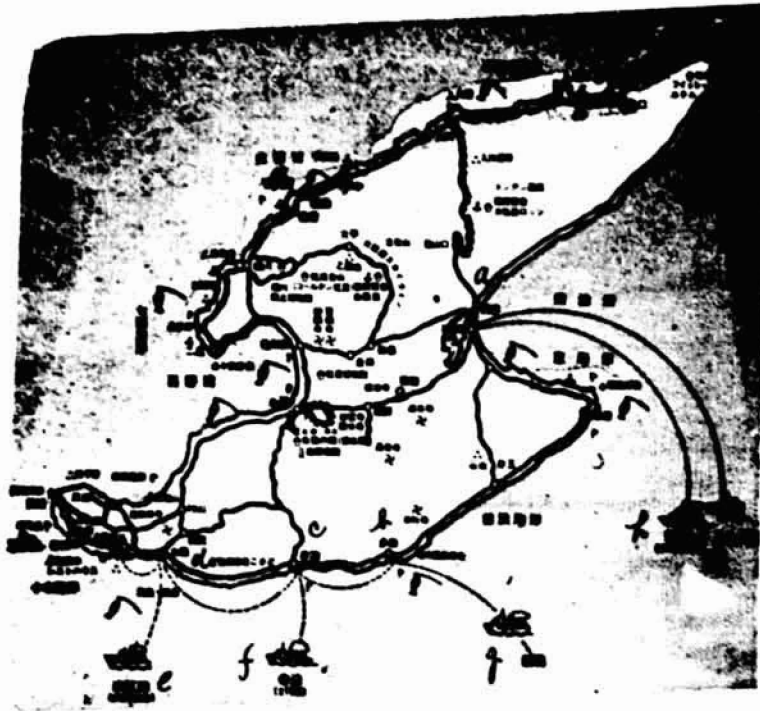

Fig.III-32. Island of Sado.

ORIGINAL PAGE IS
OF POOR QUALITY

Key:

- a: Ryozu
- b: Tada
- c: Akadomari
- d: Oh'hashi
- e: To Naoetsu, 2 hours and a half
- f: To Teradomari, 2 hours
- g: To Niigata
- h: To Niigata, 2 hours and a half
- i: To Niigata, 30 minutes
- j: Ryozo Bay
- k: Mano Bay

佐渡汽船

THE PACIFIC
OF TOUR QUALITY



波高3.7mの荒海でも速い、揺れない、酔わない超高速船

ジェットジョイフル

5月 日本初就航 新潟→両津55分

Fig. III-33-1. Advertisement Brochure.

Key to Fig. III-33-1.

A: Island of Sado

B: Even in a rough sea, with waves 3.7 meter high, our super-high speed ship is fast, does not rock and you will not be sea-sick.

C: JET FOIL

D: First Sailing in May. The first time in Japan.

55 Minutes from Niigata to Ryoju.



ジェットが行く 海の滑走路。



B 客室は、1階と2階に別れており、室内は広く通路の幅は90cm、天井の高さは2m、座席幅も広くゆったりとし、室内温度は20℃から25℃に保ち常に快適な航海をします。



- 定員/278名 ●噸数/296トン
- 全長/30.7m ●最大速力(時速)/89km
- 推進力/ウォータージェットエンジン
- 水中翼/動翼(フラップ)付
- コンピューター自動制御

D ジェットフォイル

55分

新潟 ← 新潟 → 両津

E 波高3.7mの荒海でも時速80 Kmのスピードを維持し、しかも酔いがない!

F 快適な乗心地
ジェットフォイルは、コンピューターで自動制御される全没型の動翼付前後水中翼の働きにより、船体を海面から完全に離上させて走行するので、波高3.7mの悪天候下でも、ピッチング(船の縦揺)やローリング(船の横揺)がなく、乗客は、酔いをまったく感じません

H 超高速
ジェットフォイルは、1分間に約100トン(巾4m、深さ1m、長さ25mのプールの満水量)の海水を高圧力で噴射するウォーター・ジェットポンプの推力により、時速80km以上のスピードで疾走いたします

G 安全性
ジェットフォイルは、水中翼に宇宙開発の技術に応用した特殊装置を採用しているため、たとえ時速80kmで海上浮遊物(直径30cmの材木等)との衝突があったとしても安全であり、乗客はショックを感じません。又、衝撃と考えられる構造上のシステムは、自己検知ができるうえ、すべて二重になっており、たとえ故障があっても、船の航行にはまったく影響ありません

I 無公害
ジェットフォイルは、海洋汚染防止装置として航空機で採用しているものと同様の汚水処理装置を取り付けており、排気も、きれいなので大気汚染、海洋汚染等の公害問題を引起こす心配は、ありません。又、騒音が低く、通り道も残さないため、他の船舶や、沿岸住民に迷惑をおよぼすおそれはありません

Fig. III-33-2. Advertisement Brochure.

Key to Fig. III-33-2.

- A: Smooth Sailing on the Sea.
- B: Passenger space is divided between the first and second levels. The rooms are spacious, the corridor being 92 cm wide and the ceiling 2 m high. The seats are large and comfortable and the room temperature stays between 20 and 25 C^o, so everyone can enjoy a pleasant ride.
- C: Capacity : 278 passengers Tonnage: 296 tons
Length: 30.7 m Maximum Speed : 89 km/hour
Propelling Means: Water Jet Engine
Water Wings with Flaps
Automatically Controlled by Computer
- D: JET FOIL - 55 Minutes from Niigata to Ryoju
- E: Even on rough seas with 3.7-m waves, moving at a speed of 80 km/hour, you will not be sea sick !
- F: Comfortable Sailing: Because of the movement of the automatic computer controlled fully submerged water wings in front and back of the jet-foil, the body of the ship is completely removed from the surface of the sea. Thus even in rough weather conditions, with waves 3.7 meters in height, there is no pitching and rolling and passengers will never experience sea sickness.
- G: Safety: The water wings of the jetfoil are equipped with shock absorbing means which have been developed by applying space development techniques, so that even when moving at a speed of 80 km/hour, if the vessel collides with buoys (for instance logs 30 cm in diameter) safety is assured ; passengers will not even feel the impact. Every essential system has self-detecting mechanisms as well as dual structure, so that even in the case of a mechanical failure, the operation of the ship will remain unaffected.
- H: High Speed: Due to the propelling action of the jet water pump which thrusts about 100 tons of water (a pool of water with a width of 4m, depth of 1 m and length of 25 m) per minute with high pressure, the jetfoil can move at the high speed of more than 80 km/hour.
- I: No Pollution: The jetfoils' facilities are equipped with a mechanism which prevents the expulsion of waste materials into the waters, just as the mechanism in an airplane. The jetfoil's exhaust is clean and thus there is no fear of its causing either air or water pollution problems. Furthermore, the ship's noise is insignificant, and a wake is not created, and thus there is no fear that other vessels or those living along the shore will be inconvenienced.

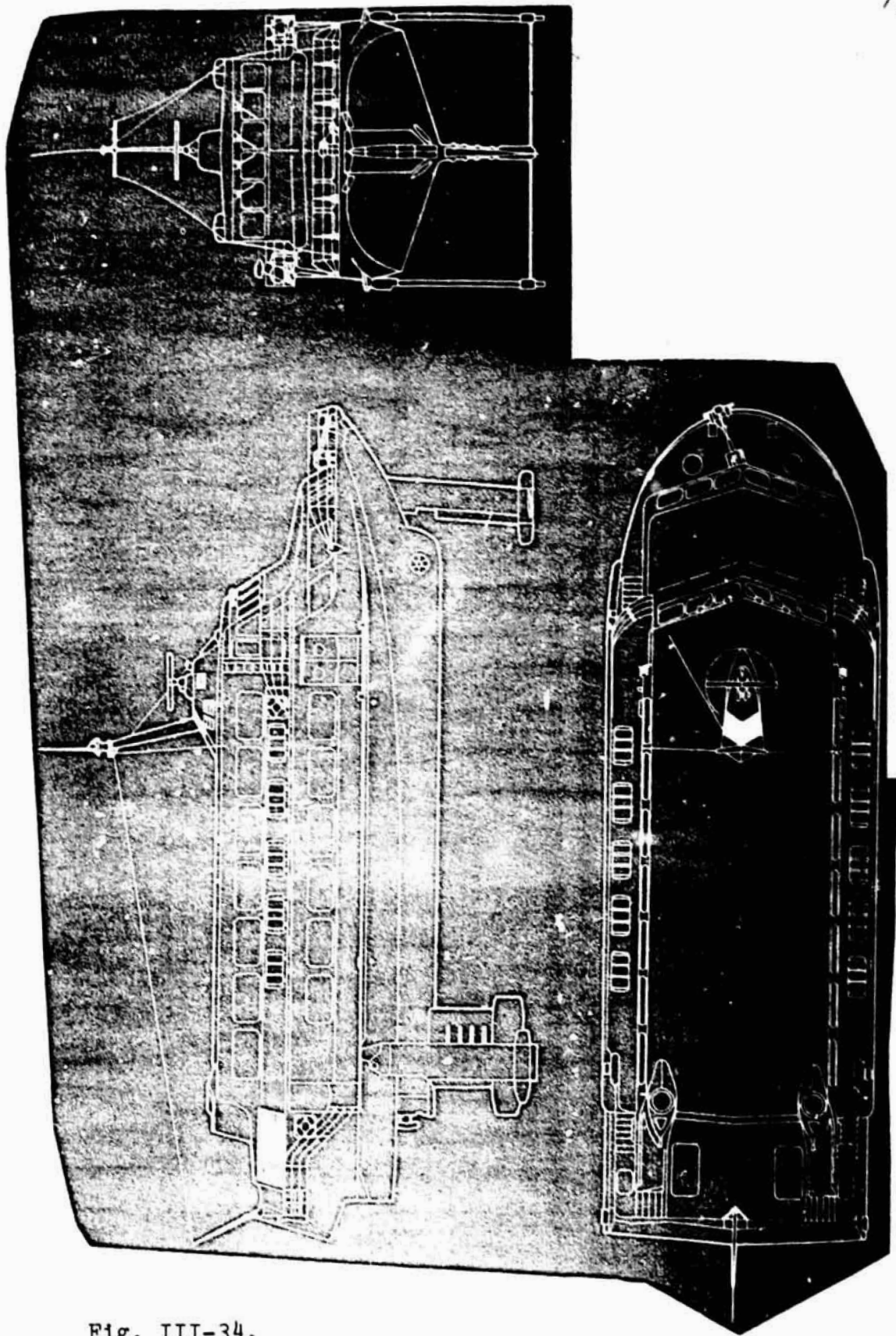

Fig. III-34.
From Advertisement Brochure.

ORIGINAL PAGE IS
OF POOR QUALITY

A Table III-15

B 両津航路 (新潟-両津)

区分 運賃金	一般旅客				団体旅客			
	片道	往復	季節割引 (11月1日-3月31日)		片道	往復	季節割引 (11月1日-3月31日)	
			片道	往復			片道	往復
ジェットfoil	4,000	7,780	3,560	6,940	3,780	7,360	3,340	6,530
内運賃	2,200	4,180	1,760	3,340	1,980	3,760	1,540	2,930
外運賃	1,800	3,600	1,800	3,600	1,800	3,600	1,800	3,600

C 昭和52年 佐渡汽船ジェットfoil時刻表・運賃表

D 両津航路 (新潟-両津)

区間	新潟発→両津着	両津発→新潟着	区間	新潟発→両津着	両津発→新潟着
5月1日～7月20日	6:30→7:25	7:55→8:50	9月1日～11月5日	6:30→7:25	7:55→8:50
	9:45→10:40	11:10→12:05		9:45→10:40	11:10→12:05
	13:05→14:00	14:25→15:20		13:05→14:00	14:25→15:20
	16:00→16:55	17:20→18:15		13:05→14:00	14:25→15:20
7月21日～8月20日	5:50→6:45	7:00→7:55	11月6日～3月31日	7:20→8:15	8:50→9:45
	8:25→9:20	9:45→10:40		13:10→14:05	15:00→15:55
	11:10→12:05	12:25→13:20			
	13:50→14:45	15:05→16:00			
	16:30→17:25	17:45→18:40			

Key:

- A: Table of Fare
- B: Ryoju Route
- C: Time/Fare Table, 1977 Sado Steamboat's Jetfoil
- D: Ryuzu Route
- a: classification
- b: regular fare
- c: group fare
- d: fare
- e: one way
- f: round trip
- g: seasonal discount
- h: one way
- i: round trip
- j: one way
- k: round trip
- l: seasonal discount
- m: one way
- n: round trip
- o: JETFOIL fare
- p: itemization
- q: regular fare
- r: express charge
- s: period
- t: 5/1 - 7/20 and 8/21 - 8/31 (discontinued from 6/20 to 6/24 for inspection)
- u: 7/21 - 8/20
- v: From Niigata to Ryoju
- w: From Ryoju to Niigata
- x: period
- y: 9/1 - 11/5
- z: 11/6 - 3/31(/78)
- aa: From Niigata to Ryoju
- ab: From Ryoju to Niigata

Table III-16 JET FOIL

No. of Passenger	280	
Cruising Speed	80 km/hour	
Cruising Distance	500 to 700 km	
Engine	2 Units of 3800-HP engines	
Displacement Tonnage	115 tons	
Crew Members	2	
Ship Price	2.8 billion yen	
Operating Percentage	95 %	(Cf. 1)
Total Passengers	243,000	(Cf. 2)
Fare	4,000 yen/person	(Cf. 3)

Remarks: 1: from 5/1/77 (operation started) to 1/78
 2: from 5/1/77 to 1/78 (initial goal 230,000 passengers)
 3: Niigata - Ryoju

(d) Hakata to Iki/Tsushima.

/107

On the Hakata - Iki (73 km)/Tsushima (147 km) Line, steamboats are operated by Kyushu Yusen (Mailboat) Company. It takes 6 and a half hours from Hakata to Tsushima Island. The Hovercraft may reduce this time to two hours. However, it cannot be used in this line due to the high waves on Tsushima Channel. Consequently, airports for STOL plane are now under consideration.

(e) Tanegashima to Yakushima.

The two islands, Tanegashima and Yakushima, are located 115 km and 130 km from Kagoshima City, respectively. The distance between these two islands is about 30 km. On this line, three companies, Kagoshima Merchant Ships, Orita Steamlines and Kyushu Merchant Ships, are competing with each other. None of these companies is in good financial condition. Both islands have airports. The airport on Tanegashima Island is now extending its runway from 1,200 m to 1,500 m. The line may be said to be ~~having the same difficulties as the Iki - Tsushima Line.~~

(f) Problems in Air Transportation to Isolated Islands.

With respect to transportation to isolated islands, the airlines have remained totally undeveloped, in contrast to the sea-lines. Table III-17 briefly shows the present conditions of the airports in isolated islands. Presently, 14 airports are being used. Among these airports, the ones in Hachijo and Amami Islands are the most utilized; in 1970 the number of passengers using these two airports together amounted to about 200 thousand. The populations of Hachijo and Amami Islands are about 10 thousand and 90 thousand, respectively. The ratio of airport passengers to population is about 20 times and about twice, respectively. It is obvious that a large number of tourists visit Hachijo Island for sight-seeing. At the other airports except those

on Rishiri and Sado Islands, the number of passengers is several **times** more than the population. The airport in Rishiri and Sado Islands are used only by small Cessna-class airplanes which operate on irregular schedules. For this reason the passengers using these airports are far fewer than those using airports in other isolated islands.

As seen from Table III-17, airports in isolated islands are equipped at most with **runways** of only about 1,200 m in length, and the largest airplanes that can use these airports are YS-11's. The minimum length of **runway** for a YS-11 take-off and landing is said to be 1,200 m, although this may also depend on flight distance, weight, temperature and other factors. Many of these isolated islands have airports which cannot be used even by YS-11's.

As a typical example of construction works based on the 3rd Airport Innovation Plan (1976 - 1980), the construction work of Tsushima (Tsu-Island), Nagasaki Prefecture, will be described. The total construction budget is about 6 billion yen and the following works are being planned:

(1) Extension of Runway:

The present length of the runway, 1,500 m, is extended to 2,000 m. (Cf. Regular flights began in October, 1975.)

(2) Extension of Airport Aprons:

There are two YS-11 class (60-passenger) fingers at present. They are increased to three fingers and extended in size so as to accommodate B-727 class (178-passenger) airplanes.

(3) Construction of Aero-Meteorological Observation Equipment:

(4) Future Plan Associated with Extension:

Extension works for receiving airplanes which directly fly to the Kansai District are being planned.

A 島名	B 人口	C 空港名	D 指定年月日	E 滑走路 (長×幅)	F 機種	G 利用人員 (人/年)	H 区間距離 (km)
a 利尻	6,883	a 利尻	at 3種 36. 6. 1	800×25	DHC-6型 I	3,085	ca 稚内 78, ch 札幌 386
b 奥尻	5,746	b 奥尻	at " 48. 7. 1	800×25	" I	6,219	cc 札幌 34, cd 函館 141
c 大島	11,096	c 大島	ai " 39. 6. 15	1,200×30	YS-11 J	21,730	ace 東京 126
d 三宅	4,632	d 三宅	aj " 41. 3. 1	1,100×30	" J	21,640	cf 大島 76
e 八丈	10,319	e 八丈	ak " 37. 5. 1	1,500×45	" J	204,567	cf 東京 334, ch 名古屋 350
f 新島	2,945	f 新島	al 離着陸場	600	アイランド K	9,071	cf 大島 46, ch 調布 150, ci 竜ヶ崎 211
g 佐渡	88,178	g 佐渡	an 3種 35. 4. 1	890×25	DHC-6 I	31,524	an 新潟 65, cl 出雲 95, ar 米子 76, ea 大阪 431
h 隠岐	19,796	h 隠岐	ao " 43. 7. 24	1,200×30	YS-11 J	62,384	ea 大阪 431
i 福江	54,650	i 福江	aa " 35. 4. 1	1,200×30	" J	69,582	af 大村 115
j 対馬	52,127	j 対馬	aj " 46. 10. 21	1,500×45	" J	19,494	af 福岡 130
k 志岐	41,082	k 志岐	ak " 38. 3. 27	1,200×30	" J	70,713	ca 福岡 84
l 種子	46,200	l 種子	al " 37. 7. 20	1,500×45	" J	97,290	ca 鹿児島 12, ct 大阪 679
m 屋久	15,802	m 屋久	as " 33. 12. 25	1,200×45	" J	28,019	cu 鹿児島 125
n 硫黄	208	n 硫黄	at 非公用 48. 2	660×60	BN-2A-6型	3,412	cv 鹿児島 110
o 諏訪之瀬	65	o 諏訪之瀬	au " 50. 8	700×60	" L	-	cu 鹿児島 232
p 奄美	81,317	p 奄美	av 3種 39. 6. 1	1,240×30	YS-11 J	340,059	cy 鹿児島 360, da 大阪 934
q 界首	11,470	q 界首	aw " 46. 4. 1	1,320×30	" J	35,580	da 奄美 45
r 徳之島	35,396	r 徳之島	ax " 46. 8. 1	1,200×30	" J	111,363	db 鹿児島 468
s 冲永良部	16,883	s 冲永良部	ay " 44. 5. 1	1,380×30	" J	54,779	db 鹿児島 520
t 与論	6,973	t 与論	az " 51. 5. 1	1,320×120	" J	28,705	db 鹿児島 618
u 伊江	5,626	u 伊江	ba " 50. 7. 20	1,500×45	" J	3,573	dd 那覇 70
v 南大東	1,712	v 南大東	bb " 47. 5. 15	800×25	DHC-6 I	12,705	dd " 372
w 北大東	647	w 北大東	-	760×20	セスナ M	9,600	de 南大東 12
x 久米	10,079	x 久米	bc " 47. 5. 15	1,220×30	YS-11 J	104,263	da 那覇 148
y 宮古	44,996	y 宮古	bd " 47. 5. 15	1,500×45	" J	298,019	dd 那覇 360, df 石垣 133
z 多良間	1,789	z 多良間	be " 47. 5. 15	800×25	DHC-6 I	6,316	dg 宮古 52, df 石垣 69
aa 石垣	34,625	aa 石垣	bf " 47. 5. 15	1,500×45	YS-11 J	20,801	dr 与那国 129
ab 波照間	855	ab 波照間	bg " 47. 5. 15	850×25	DHC-6 I	-	df 石垣
ac 下地	-	ac 下地	建設中	3,000×60	-	-	-
ad 冲縄	-	ad 冲縄	bi 2種 47. 5. 15	2,700×45	-	-	-

ORIGINAL PAGE IS Table III-17. State of Airports on Isolated Islands.
OF POOR QUALITY

Key to Table III-17.

A: Name of Island	B: Population	C: Name of Airport
D: Date of Authorization		E: Runway (Length x Width)
F: Model of Airplane	G: Passengers per Year	H: Line Distance (km)
I: DHC-6	J: YS-11	K: Islander
L: BN-2A-6	M: Cessna	

a: Rijiri	b: Okujiri	c: Ohshima	d: Miyake
e: Hachijo	f: Nijima	g: Sado	i: Fukue
j: Tsushima	k: Iki	l: Tanega	m: Yaku
n: Iwo	o: Suwanose	p: Amami	q: Kikai
r: Tokunoshima	s: Okino-Erabu	t: Yoron	u: Iye
v: Minami-Daito	w: Kita-Daito	x: Kume	y: Miyako
z: Tarama			

aa: Ishigaki	ab: Hatema	ac: Shimoji	ad: Okinawa
ae: Hezakibara	af: Naha	ag: 6/1/61,3rd	ah: 7/1/73,3rd
ai: 6/15/64,3rd	aj: 3/1/66,3rd	ak: 5/1/62,3rd	al: take-off and landing ground
am: 4/1/60,3rd	an: 7/24/68,3rd		
ao: 4/1/60,3rd	aq: 3/27/63,3rd	ar: 7/20/62,3rd	as: 12/25/58,3rd
at: 2/73, not publicly open		au: 8/77, not publicly open	
av: 6/1/64,3rd	aw: 4/1/71,3rd	ax: 8/1/71,3rd	ay: 5/1/69,3rd
az: 5/1/76,3rd			

ba: 7/20/75,3rd	bb: 5/15/72,3rd	bc: 5/15/72,3rd	bd: 5/15/72,3rd
be: 5/15/72,3rd	bf: 5/15/72,3rd	bg: 5/15/72,3rd	bh: under construction
bi: 5/15/72,2nd			

ca: Wakkanai	cb: Sapporo	cc: Sapporo	cd: Hakodate
ce: Tokyo	cf: Ohshima	cg: Tokyo	ch: Nagoya
ci: Ohshima	cj: Chofu	ck: Ryugasaki	cl: Niigata
cm: Izumo	cn: Yonago	co: Ohmura	cq: Fukuoka
cr: Fukuoka	cs: Kagoshima	ct: Osaka	cu: Kagoshima
cv: Kagoshima	cw: Kagoshima	cx: Kagoshima	cy: Osaka
cz: Okinawa			

da: Amami	db: Kagoshima	dd: Naha	de: Minami-Daito
df: Ishigaki	dh: Yonakuni		

At present, the models of airplanes used by the airlines connecting isolated islands are the 60-passenger YS-11, the 20-passenger DCH-6 and the 4 to 10-passenger Cessna. The YS-11 plays the main role among these airplanes. When the YS-11 will be discontinued is not certain, but it is thought to be around 1980. The airplane model which will replace the YS-11 has not yet been decided.

In the future model of airplane, naturally vTOL or STOL ability is desired. The development of VTOL and STOL planes has already been started in Europe and the U.S.A. In Japan, the study of these planes has already begun.

Helicopters, as VTOL planes, and Twin Otter DHC-6's, as STOL planes, have been in practical use already. However, each of these aircraft can carry at most about 20 passengers. It can be said that these aircraft have not been established as **genuine modern passenger** transportation means. The following problems can be pointed out in connection with the development of these short-distance means of air transportation:

- (1) Technical Development of Aircraft, Particularly, STOL Aircraft.

The first step in the development of STOL aircraft has been successfully completed and about 20-passenger class aircraft are now in practical use. The main steps of development toward the goal of about 100-passenger class craft are now under way. Table III-18 summarizes what is required of VTOL/STOL plane manufacturers in various countries of the world.

Table III-18. Required Specification for V/STOL Aircraft.

	Americal (U.S.A.)	Eastern (U.S.A.)	Air Canada (Canada)	Lufthansa (W. Germany)	M.T.*** G.B.****
Kind of Plane	Propeller STOL	VTOL or STOL	VTOL	VTOL	VTOL or STOL
Desired Date for 1st Flight	1974	1973 to 1975	late 1970's		after 1980
Passengers	48 or more	100 to 120	around 130	80 to 100	around 130
Cruising Speed (km/hour)	415 or more	650 to 920	830 to 930	740 or more	720 or more
Flight Distance (km)	920	920	830	800	720
External Noise (PN dB/150 m)	95 (To Side)	95	90	95	95
Required Length of Runway (m)	610	475* 550**			

- Cf. * on the ground
 ** elevated
 *** M.T. = Ministry of Technology
 **** G.B. = Great Britain

- (2) Development of an Airline Network for STOL Planes.

/110

STOL planes are built for short-distance transportation and their flight altitude is much lower than that of usual airplanes. Therefore, the airline network and the airplane control systems must be re-organized.

- (3) Matching the Operating Cost and the Fare.

The operating cost of STOL planes is much higher than that of usual airplanes. The direct operating cost (the cost per airplane per km of flight) varies according to a variety of conditions. Table III-19 shows a comparison of the direct operating cost of STOL planes with that of usual airplanes, according to a tentative estimates. By dividing the costs in the table by the number of seats, one obtains the per-seat, per km cost which basis for calculating the air fare. The table does not show a direct comparison of the air fares. However, based on the estimates shown in the table, the fare of STOL planes to be about twice as high or more than that of usual airplanes.

Table III-19.

Name of Model		Direct Cost per km	
Usual Airplanes	YS-11 (64 seats)	0.959 Dollars	Piedmont Co., U.S.A., 1976
	F-27 (48 seats)	0.914	Average of 7 Co's, in the U.S.A.
	Convair (53 seats)	0.85	Average of 3 Co's, in the U.S.A.
STOL	DHC-6 (20 seats)	0.85 (240 km*)	Annual Operating Time = 2,000 hours
		* 0.891(160 km*)	
		1.025(80 km*)	

Cf. * Line Distance

In fact, the STOL operation in the U.S.A. is not at all profitable at present and is able to continue only due to a substantial amount of governmental aid.

In Japan, the STOL plane operation started in 1972 with DCH-6 Twin Otters which are used by the airline connecting Yonakuni, Ishigaki and Tara Islands. Due to the poor profitability, the Japanese government subsidized the operation with 140 million yen, about 68 % of the purchase price of the aircraft.

At any rate, the STOL plane operation will require substantial financial aid for at least the immediate future.

In Japan, in keeping with the basic policy to improve the speed and the frequency of service among the airlines connecting isolated islands, the introduction of STOL planes to those lines will be subsidized by the government with 50 % of the purchase price.

The construction of heliports for emergency is also under way in many isolated islands. The number of islands which have heliports is at present 50.

Cargo transportation among isolated islands is so irregular /111 that it may be concluded that only charter flights and not scheduled flights can be profitable. The cargo transportation to and from isolated islands has reached the level of 40 million tons (to) and 38 million tons (from) per year, at present. The construction of a harbor at which 500-ton class ships can anchor costs more than one billion yen. For an island with a population less than 1,000, it is considered impossible to construct such a harbor. Therefore, airships which do not need such harbors will be very advantageous in this field.

III-3-4. STOL Aircraft Development in Our Country.

The study of STOL aircraft began in Japan in the fiscal year 1977 in the Aeronautic and Space Technology Research Laboratory which belongs to the Science and Technology Agency. The first flight of an experimental model is now being planned for the spring of 1982. The investment in the development of the STOL aircraft will have finally amounted to 17 billion yen through about ten years from fiscal year 1975.

According to the plan of the same laboratory, the required runway length will be 900 m, namely, be shorter than the 1,200 m length which is required by the YS-11 and about half as long as that required by conventionally used jet planes. The plan is for STOL aircraft to use not the main runways in large airports but runways specially constructed for STOL planes. According to this plan, the aircraft will have 150 passenger seats, a speed of 0.7 to 0.8 Mach number, low noise and economical efficiency, and will guarantee almost the same profitability as that of jet planes conventionally used by 200 to 800-m airlines.

In the fiscal year 1977, after the study began, the 190-million-yen budget included basic designs, calculation of aerodynamic characteristics and flight performances, etc.

A 1.5-billion-yen budget for completing basic design and for trial-manufacturing aircraft parts is being planned for the fiscal year 1978.

This model of STOL aircraft will use the body of the transportation plane C-1. It will be equipped with newly developed engines specially designed for STOL planes. It was decided that the STOL planes be furnished with the approximately 5-ton-thrust fan-jet engine, FJR-710, whose development has been promoted by the Ministry of International Trade and Industry as a large-scale national project. The transportation plane C-1 was chosen as the basis for the future STOL aircraft in an attempt to reduce development costs and the amount of time necessary for its development. Thus, the C-1 plane with new STOL engines will be the first STOL plane which is trial-built. However, this plane will be built mainly for experimental reasons. The expectations are that a genuine STOL aircraft with about 150 passenger seats will be further developed based on the experimental STOL plane. In case the demand for STOL aircraft increases rapidly, the STOL aircraft based on the C-1 plane will be used as a 60 to 80-passenger aircraft.

The development schedule is as follows:

**ORIGINAL PAGE IS
OF POOR QUALITY**

Fiscal Year

1978:	Basic designs completed.
1979 to 1980:	Detailed designs and trial-manufacturing of the aircraft parts.
1978 to 1980:	Tests.
1979 to 1981:	Manufacturing of a test plane.
1982, Spring:	The first flight of the test plane.

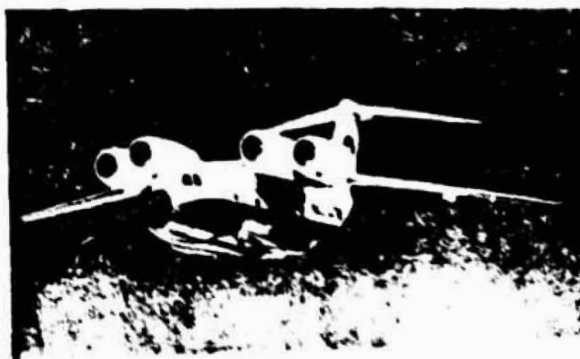

112

Photograph of Experimental Plane Manufactured by
STOL Research Laboratory of Aeronautic
Technology Research Institute.

Isolated Islands of Hokkaido

- Rebun, Rishiri and Okujiri Islands -

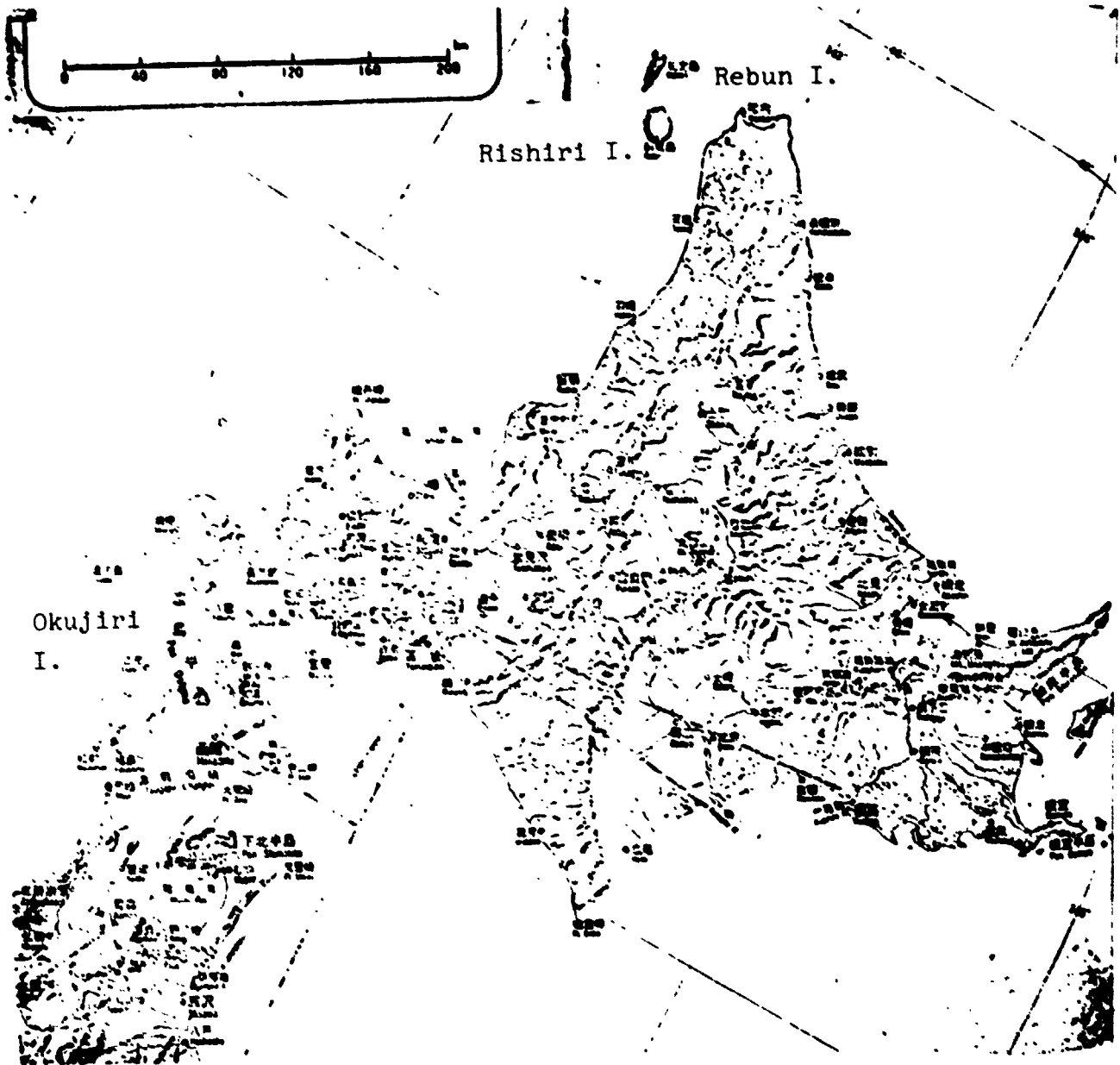

年次	火災被害額 (千円)		火災被害額 (千円)		火災被害額 (千円)		火災被害額 (千円)		火災被害額 (千円)		火災被害額 (千円)	
	合計	建物	家財	自動車	船舶	航空機	その他	合計	建物	家財	自動車	船舶
21	14,467	14,467	-	-	-	-	-	23,954	23,954	3,333,057	-	-
22	18,806	15,888	2,918	3,909,917	485	3,909,917	485	34,283	34,283	10,964,194	-	-
23	17,022	15,099	1,923	3,065,084	407	3,065,084	407	22,561	22,561	13,323,769	-	-
24	18,484	16,346	1,334	2,236,649	425	2,236,649	425	25,908	25,908	26,997,306	26,153,076	-
25	19,243	16,663	1,161	3,271,516	423	3,271,516	423	20,589	20,589	12,812,186	21,206,878	-
26	21,223	18,136	1,582	1,637,368	678	1,637,368	678	20,234	20,234	22,228,151	21,847,966	-
27	22,075	18,350	1,501	6,054,576	471	6,054,576	471	21,368	21,368	28,614,883	27,704,725	-
28	25,677	21,214	1,726	5,289,788	493	5,289,788	493	17,585	17,585	24,255,833	23,294,294	-
29	27,870	22,612	1,579	1,112,726	523	1,112,726	523	27,567	27,567	32,859,786	32,229,667	-
30	29,947	23,769	1,810	555,849	694	555,849	694	29,234	29,234	31,652,417	31,301,021	-
31	33,312	2,814	2,109	1,515,085	640	1,515,085	640	31,250	31,250	37,128,328	35,546,526	-
32	34,650	26,170	2,844	1,638,211	624	1,638,211	624	28,385	28,385	36,251,287	32,522,522	-
33	36,178	27,861	2,729	614,885	593	614,885	593	30,942	30,942	21,769,898	21,198,296	-
34	36,913	28,218	2,093	1,144,534	652	1,144,534	652	35,067	35,067	28,803,401	28,367,075	-
35	43,679	31,187	3,941	1,253,790	780	1,253,790	780	34,220	34,220	24,423,613	23,418,998	-
36	47,106	32,514	4,209	18,266,307	806	18,266,307	806	5,804	5,804	43,020,927	35,092,254	-
37	49,644	33,532	5,049	1,274,708	861	1,274,708	861	37,070	37,070	40,192,998	38,174,597	-
38	50,478	33,546	5,443	1,945,517	853	1,945,517	853	35,624	35,624	29,620,771	28,481,762	-
39	49,020	33,617	4,572	821,496	940	821,496	940	35,267	35,267	52,908,641	46,876,331	-
40	54,157	34,614	7,842	2,099,485	965	2,099,485	965	35,935	35,935	51,203,175	44,807,241	-
41	48,057	32,983	4,336	890,964	1,111	890,964	1,111	33,764	33,764	48,865,228	43,964,947	-
42	54,506	35,687	6,823	1,129,115	1,100	1,129,115	1,100	36,440	36,440	53,294,553	49,792,014	-
43	53,654	34,453	6,628	1,270,689	1,100	1,270,689	1,100	34,164	34,164	54,252,470	50,061,631	-
44	56,797	37,653	5,348	1,508,517	1,334	1,508,517	1,334	39,827	39,827	70,171,860	64,988,676	-
45	63,905	39,845	7,032	1,462,299	1,595	1,462,299	1,595	41,782	41,782	83,387,083	77,142,149	-
46	64,019	39,549	7,101	1,247,049	1,493	1,247,049	1,493	42,636	42,636	78,589,529	73,759,751	-
47	58,591	38,868	4,541	471,847	1,672	471,847	1,672	40,176	40,176	84,106,133	80,955,770	-
48	73,072	42,551	8,311	840,278	1,870	840,278	1,870	43,464	43,464	112,795,975	108,821,401	-
49	67,712	39,143	8,351	1,093,723	1,610	1,093,723	1,610	40,153	40,153	126,899	104,988,973	-
50	62,212	38,425	5,517	698,419	1,674	698,419	1,674	39,030	39,030	110,148,495	106,427,660	-

Table III-21. Fire Damage Since 1946. (Citation from Fire-Fighting White Paper, 1977).

ORIGINAL PAGE IS OF POOR QUALITY.

DE POOR QUALITY

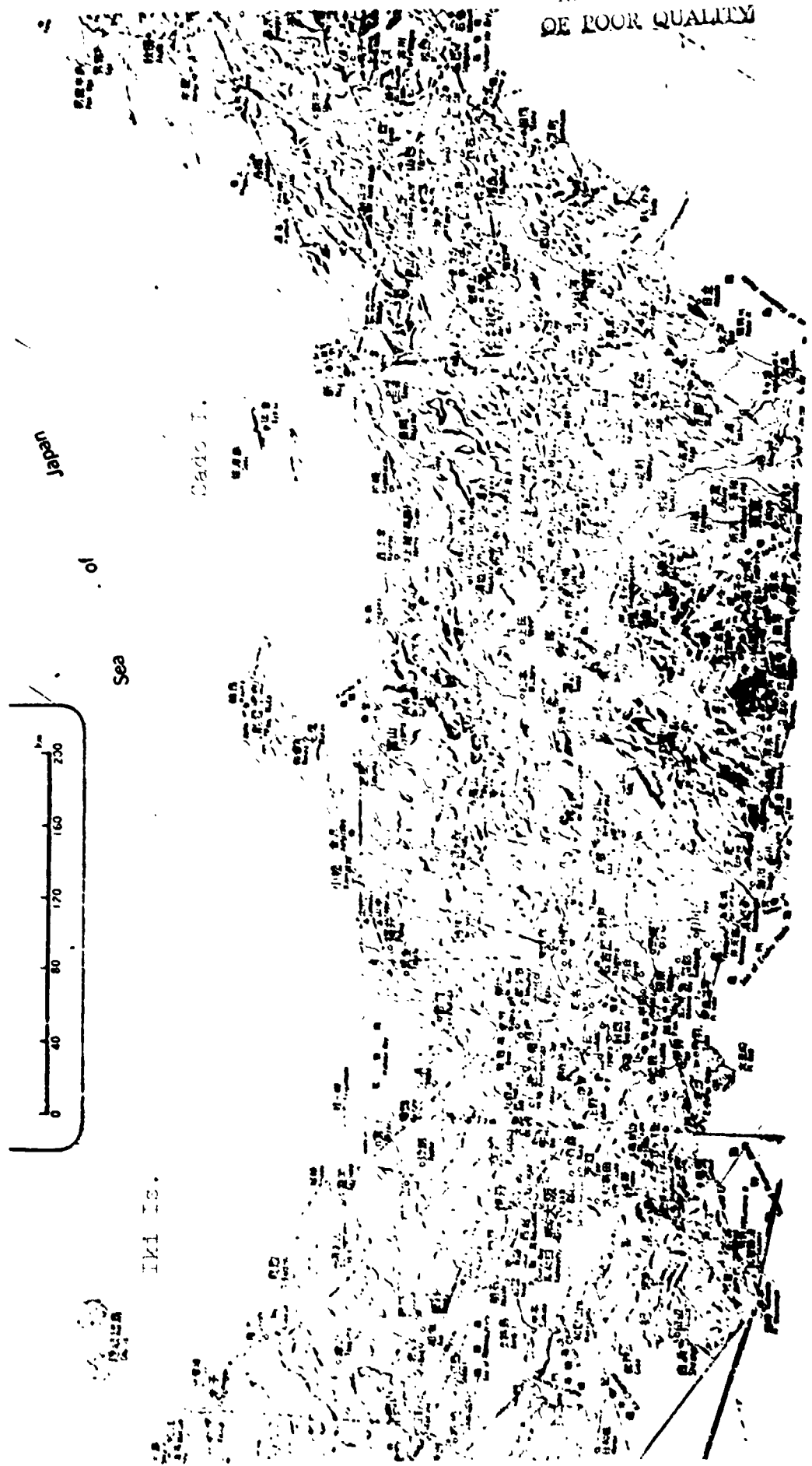

Iki Is.

Sado I.

Japan Sea

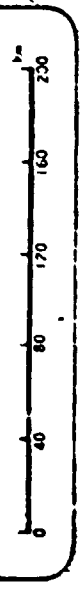

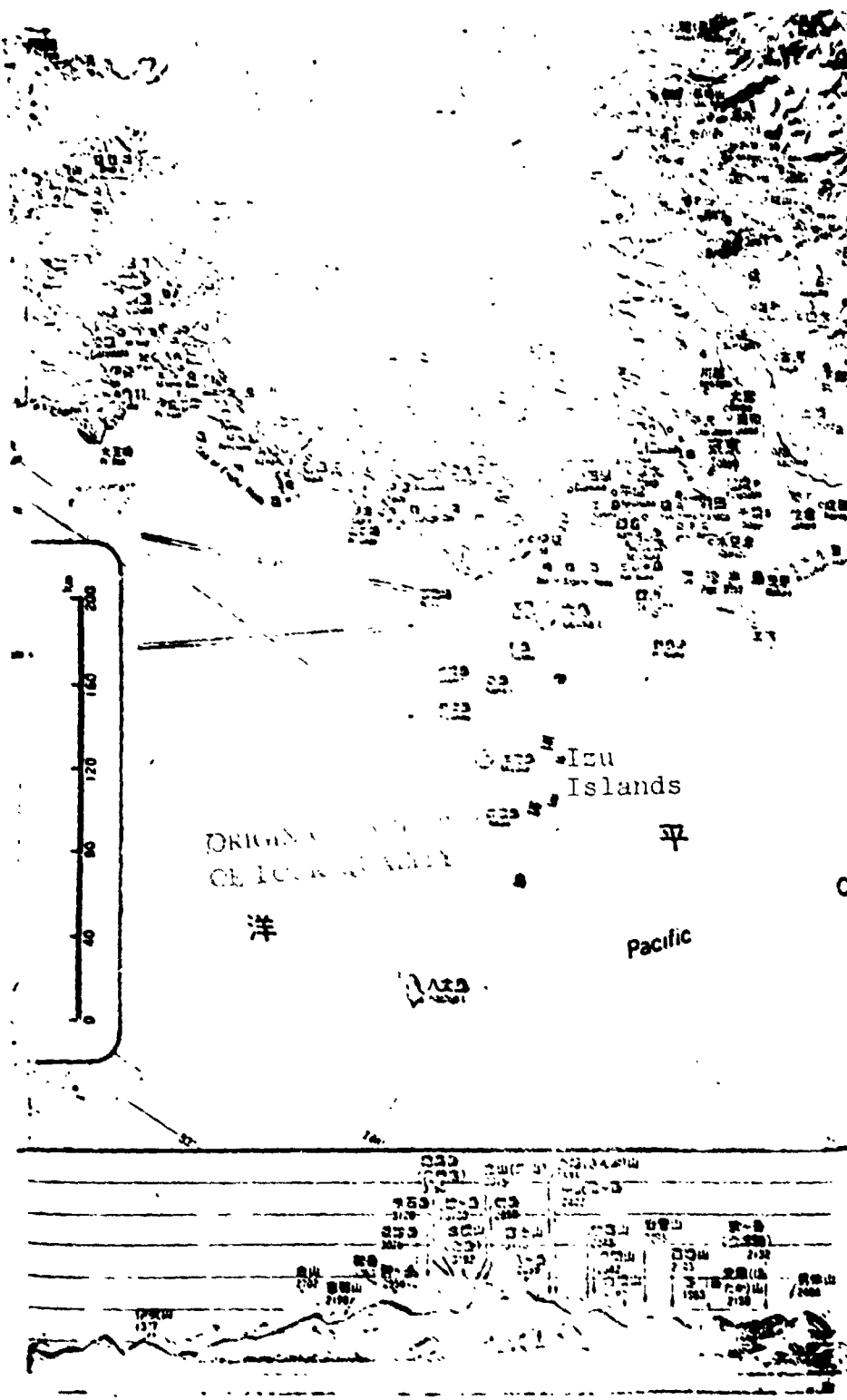

Izu Islands.

ORIGINAL PAGE IS
OF POOR QUALITY

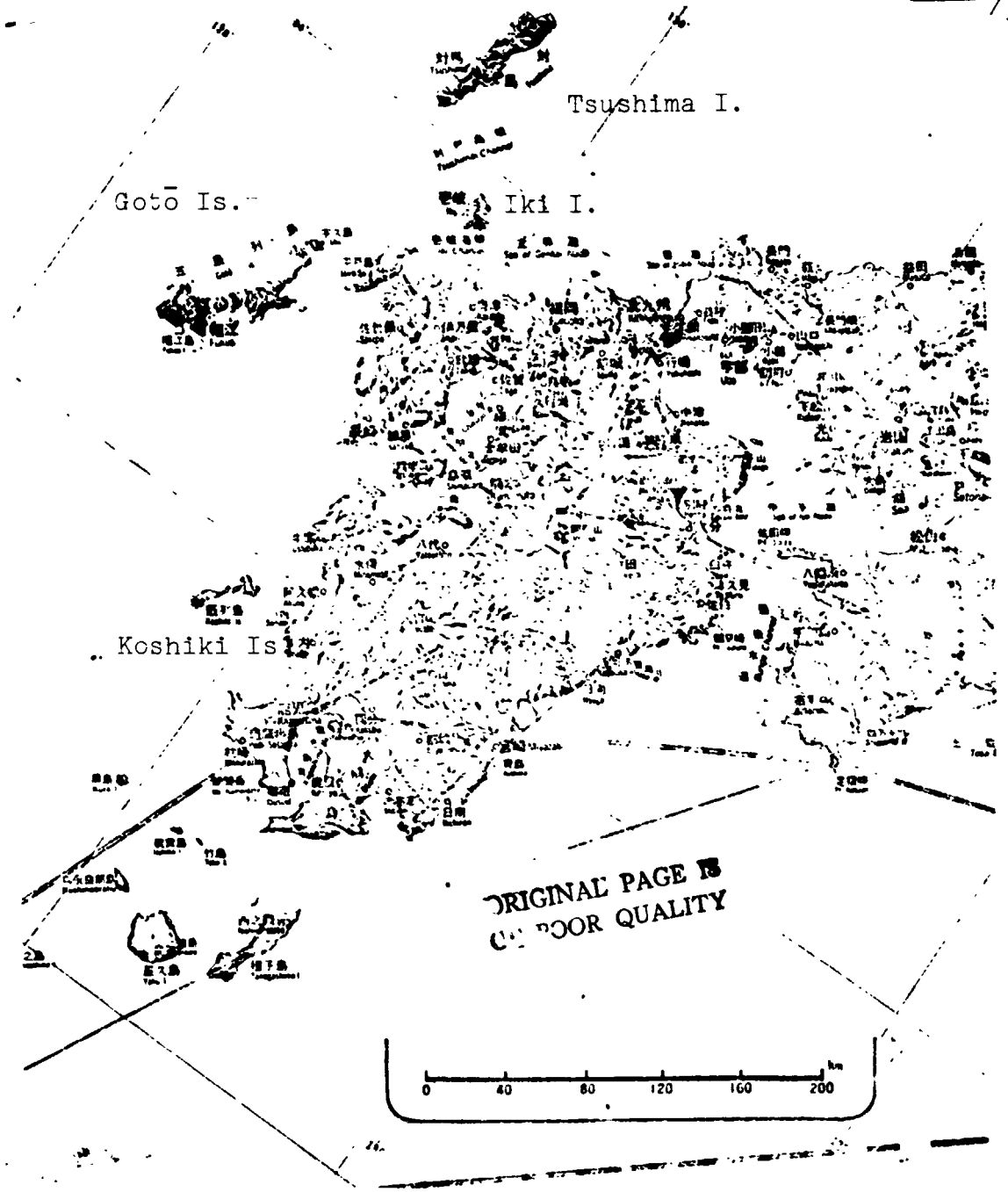

Isolated Islands in the North-West of Kyūshū.

- Tsushima I., Iki I., Gotō Is., Koshiki Is., etc.)

Key to Table III-22.

a: Classification b: Date of Earthquake c: District or Name of Earthquake
d: Magnitude e: House Damage f: Totally Destroyed
g: Totally Burned h: Washed Away i: Total
j: Dead k: No. of dead per 100 destroyed houses.
l: Cases where totally burned down or washed away houses were not recorded.
m: 1/15/24 n: 6/26/30 o: 6/21/31
p: 7/11/35 q: 5/1/39 r: 1/3/45
s: 7/26/49 t: 2/2/61 u: 4/30/62
v: 6/16/64 w: 2/21/68 x: Tanzawa Mts.
y: Kita-Izu Earthquake z: Nishi-Tama Earthquake
aa: Neighborhood of Shizuoka City ab: Ojika Peninsula
ac: Mikawa Earthquake ad: Imaichi Earthquake
ae: Near Nagaoka af: North of Miyagi Prefecture
ag: Niigata Earthquake ah: Ebino Earthquake ai: Total
aj: Cases where totally burned down houses were recorded.
ak: 5/23/25 al: 3/7/27 am: 9/10/43
an: 6/28/48 ao: 5/16/68 ap: 5/9/74
aq: North of Hyogo Prefecture ar: Kita-Tango Earthquake
as: Tottori Earthquake at: Fukui Earthquake au: Tokachioki Earthquake
av: Izu-Peninsula Earthquake aw: Total
ax: Cases where washed away houses were recorded.
ay: 9/1/23 az: 3/3/33 ba: 12/7/44
bb: 7/21/46 bc: 3, 4/52 bd: 5/23/60
be: Great Earthquake Disaster of Kanto District
bf: Sanriku Earthquake and Tidal Wave bg: Higashi-Nankai Earthquake

bh: Nankai Earthquake bi: Tokachioki Earthquake
bj: Chile Earthquake Tidal Waves bk: Total
bl: Remarks:

1. The record is cited from the "Scientific Chronological Table," published in 1976. The disasters where the number of destroyed houses is more than 100 are listed in this table.
2. * totally destroyed by tidal waves.
3. The number of the dead includes the number of the missing.

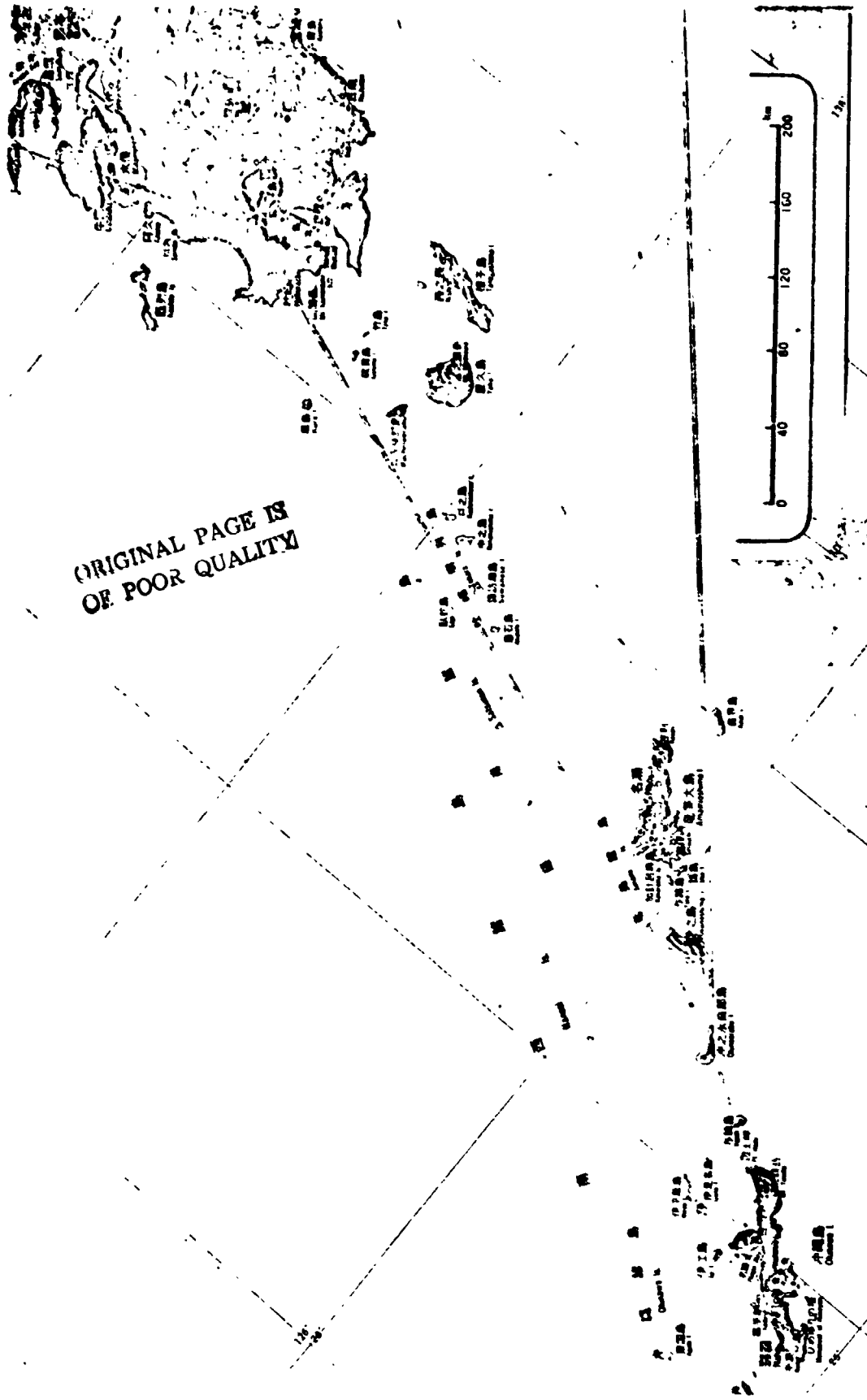

ORIGINAL PAGE IS
OF POOR QUALITY

Isolated Islands in the South-West of Kyushu (Up to Okinawa)

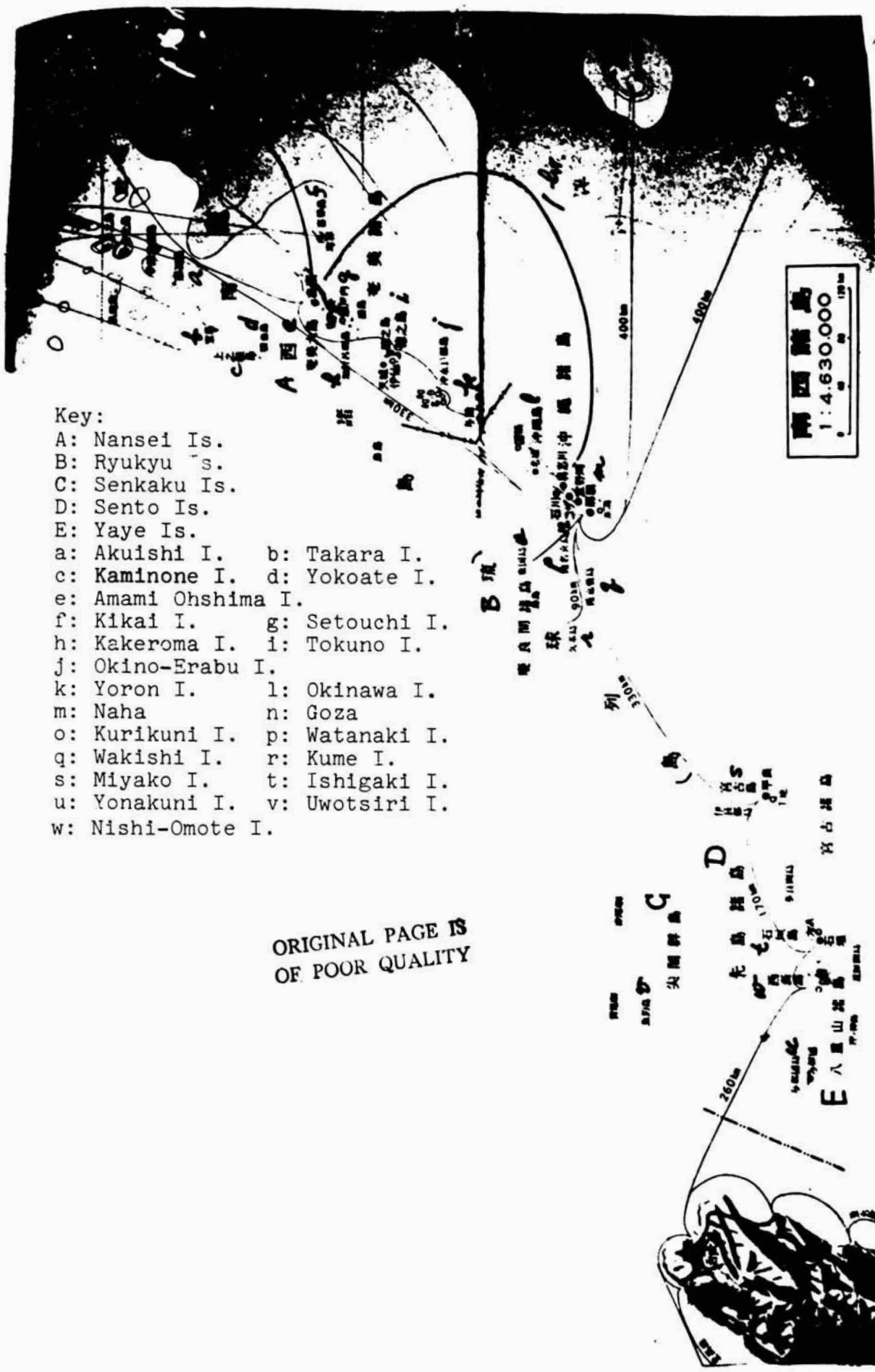

南西諸島
1:4,630,000

- Key:
- A: Nansei Is.
 - B: Ryukyu Is.
 - C: Senkaku Is.
 - D: Sento Is.
 - E: Yaye Is.
 - a: Akuishi I.
 - b: Takara I.
 - c: Kaminone I.
 - d: Yokoate I.
 - e: Amami Ohshima I.
 - f: Kikai I.
 - g: Setouchi I.
 - h: Kakeroma I.
 - i: Tokuno I.
 - j: Okino-Erabu I.
 - k: Yoron I.
 - l: Okinawa I.
 - m: Naha
 - n: Goza
 - o: Kurikuni I.
 - p: Watanaki I.
 - q: Wakishi I.
 - r: Kume I.
 - s: Miyako I.
 - t: Ishigaki I.
 - u: Yonakuni I.
 - v: Uwotsiri I.
 - w: Nishi-Omote I.

ORIGINAL PAGE IS
OF POOR QUALITY

ORIGINAL PAGE IS
OF POOR QUALITY

118



Japan Islands.

III-4. Social Requirements for Means of Airborne Assistance in
the Event of Emergencies.

/119

In this section, recent disasters in Japan will first be described. This will be followed by an examination of the necessity for emergency and rescue systems which have free three-dimensional accessibility. The advantages of airships in this field will then be described.

This section begins with a description of storm and flood damage. Table III-20 shows the major storms and flood disasters in Japan since World War II. The table shows the disasters which caused more than 50 persons to die or be missing. Our country is very mountainous and has very complicated geographical features. In summer, many typhoons approach Japan causing intensive heavy rain as well as strong winds. For example, the heavy rain which struck Japan in July, 1974 left 447 persons dead or missing, 813 injured, about 3,000 houses totally destroyed, and about 20 thousand land-slides. About 40 thousand public facilities such as roads and bridges were damaged. The total damage amounts to about 300 billion yen. In mountainous areas, land-slides occurred frequently and many rescue personnel, and even reporters, became victims of them. In disaster areas, the Act of Assistance to Disaster Areas was adopted and the government assisted the area in the construction of refuges, supply of first-aid medical care, rescue of the trapped people, burial of the dead, etc.

Next conflagrations will be described. Table III-21 shows the fire damage since World War II. The number of people who die in fires is said to be about 10 to 15 % of the number of people killed in car accidents. Due to the increase in high buildings and general congestion in the cities, the number of people who die in fires has gradually increased. Since 1973, the annual amount of building and forest damage by fire has surpassed 100 billion yen. The annual amount of forest damage alone was over five billion yen in some years. The destroyed forest area amounts to 180 thousand ha.

City fires often claim many victims at a time. This kind of fire disaster in a skyscraper was depicted in the movie, "Towering Inferno" which was recently made in the U.S.A. The fires in the department stores in Kyushu, Japan, and in Brazil remain vividly in one's mind. In such city fires, transportation congestion hinders fire engines and ambulance cars from immediately reaching the fire or the nearby hydrants. As in the case of fires in the two above-mentioned department stores, sometimes, the fire engine ladders cannot reach the uppermost floors and many victims die before the eyes of helpless fire fighters.

Japan is one country which has a number of volcanoes. The Japanese Islands have eight volcanic chains including Fuji Volcanic Chain. The volcanoes belonging to the Quaternary of the Cenozoic Era number almost 200. Among them, about 70 volcanoes are active volcanoes, in a wide sense, which may possibly explode even with slightest probability. These comprise almost 10 % of all the active volcanoes in the world. Meteoric stones, volcanic ash, lava streams, etc., cause tremendous damage in terms of human lives, houses and agricultural products,

被害発生年月日	災害種目	人的被害			住宅被害			被害総額
		死者不明	行方不明	負傷者	全壊	半壊	床上浸水	
23. 9. 11-12	水	121	126	3.7	391	872	246	2,026
9. 1	17.7イオン台風	512	326	1,956	5,889	12,127	44,867	75,168
24. 6. 18-22	アラ台風	252	216	367	1,410	4,005	4,627	52,926
8. 13-18	ジュンクス台風	154	25	213	569	1,966	33,680	68,314
8. 31-9. 1	クワイ台風	135	25	479	3,733	13,470	51,899	92,161
25. 1. 10-14	風	11	109		43	56		25
5. 19-21	風	1	58	2	6	1		
6. 9	山崩れ	50		23	5			
6. 3-14	水害・山崩れ	1	58	2	6	1	75	
8. 3-6	風水害・山崩れ	40	59	764	286	90	10,958	21,335
9. 3-4	シューン台風	398	141	26,062	19,131	101,792	93,116	308,960
9. 13-15	ヤジ7台風	51	12	303	1,417	5,786	31,927	153,800
7. 7-17	水	162	144	358	630	727	13,532	89,766
10. 13-15	ルース台風	572	371	2,644	24,716	47,948	30,110	108,163
27. 6. 22-24	グイナ台風	65	70	28	73	89	4,770	35,692
7. 10-12	水	67	73	101	356	238	20,733	21,456
6. 4-8	台風2号	37	17	56	147	135	1,810	3,830
6. 23-30	水	748	265	2,720	5,639	11,671	199,979	254,651
7. 16-25	水	713	411	5,819	7,704	2,125	20,277	66,202
8. 11-13	水	290	140	994	893	765	6,777	11,034
9. 27-28	台風13号	292	85	2,556	8,904	17,467	144,300	261,575
		172	498	59	172	498	606	1,471
		30	33	77	361	1,321	3,797	28
		107	37	311	2,162	5,746	45,040	134
		36	24	59	119	141	6,057	34
		1,301	400	1,601	8,306	21,771	17,569	81
		16	104	18	42	100	77	
		91	4	34	42	42	3,024	15
		166						
		54	14	314	6,412	13,046	10,184	41
		47	53		2	10	1,087	1
		60	10	37	160	134	8,775	22
		23	47	22	82	51	671	4
		30	23	33	108	127	24,163	107
		586	136	3,860	1,564	2,802	24,046	49
		174	38					6
		25	47	111	390	526	8,934	39
		888	381	1,138	2,118	175	132,227	389
		44	16	77	193	182	8,539	68
		188	47	1,528	4,089	10,139	32,298	116
		61	6	715	344	806	13,569	35
		69	59	454	1,425	2,838	4,174	114

Table III-20-1. Record of Storm and Flood Damage Since 1946. (1)
 (Citation from Fire-Fighting White Paper, 1977)

ORIGINAL PAGE IS
 OF POOR QUALITY

Key to Table III-20-1.

a: Date of Disaster	b: Kind of Disaster	c: Personal Disaster
d: Dead	e: Missing	f: Injured
g: Damage of Houses	h: Totally Destroyed (Washed Away)	
i: Partially Destroyed	j: Flood over the Floor	
k: Flood under the Floor		l: person
m: number c houses	n: 9/11/48	o: 6/18/49
p: 1/10/50	q: 7/7/51	r: 6/22/52
s: 6/4/53	t: 5/8/54	u: 2/19/55
v: 4/17/56	w: 6/27/57	x: 1/26/58
y: 7/13/59		

aa: flood	ab: Irene Typhoon	ac: Typhoon Della
ad: Typhoon Judith	ae: Typhoon Kitty	af: storm
af: storm/flood	ah: land-slide	ai: flood and land-slide
aj: storm/flood and land-slide		ak: Typhoon Jane
al: Typhoon Kijia	am: flood	an: Typhoon Ruth
ao: Typhoon Dinah	aq: Typhoon 2	ar: flood
as: flood	at: flood	au: Typhoon 13
av: storm	aw: Typhoon 5	ax: Typhoon 12
ay: Typhoon 14	az: Typhoon 15	ba: storm
bb: flood and land-slide		bc: fog
bd: Typhoon 22	be: storm/flood	bf: flood
bg: flood/land-slide	bh: Typhoon 5	bi: Isahaya Flood
bj: storm/high-wave	bk: Typhoon 21	bl: Typhoon 22
bm: flood/land-slide	bn: Typhoon 7	bo: flood/land-slide
bq: Typhoon 14		

被害発生年月日	災害項目	人的被害		住宅被害		被害発生年月日	災害項目	人的被害		住宅被害		
		死者不明(人)	死者(人)	全壊(戸)	半壊(戸)			死者不明(人)	死者(人)	全壊(戸)	半壊(戸)	
33. 6. 26~27	台風15号(伊勢湾台風)	40	158,921	80,838	113,052	46	8	18	291	786	63	749
34. 10. 16~19	台風18号	122	872	6,943	2,136	122	17	872	6,943	2,136	23,322	18,494
35. 8. 24	台風16号	49	6	126	290	49	6	126	216	290	7,714	33,145
36. 6. 24~7. 5	水害・山崩れ	302	55	1,320	1,908	302	55	1,320	1,758	1,908	73,126	341,236
37. 9. 15~16	台風18号(第二号台風)	194	8	4,972	46,663	194	8	4,972	15,238	46,663	123,103	261,017
38. 7. 17~20	水害・山崩れ	114	17	114	263	76	31	26	234	444	10,435	50,313
39. 9. 24~26	台風20号	47	4	664	4,235	47	4	664	4,235	11,099	11,487	45,267
40. 9. 10~18	台風23・24・25号	153	28	1,206	3,529	153	28	1,206	1,879	3,529	46,183	258,239
41. 6. 27~	台風4号	63	7	96	138	63	7	96	116	138	26,670	107,449
42. 7. 8~9	水害・山崩れ	102	16	152	163	102	16	152	163	169	17,213	103,731
43. 8. 17	水害・山崩れ(豊川)	106	13	28	64	106	13	28	64	406	26,641	39,512
44. 6. 24~7. 11	水害	64	5	743	367	64	5	743	367	612	12,860	105,888
45. 7. 16~26	水害・山崩れ	64	1	171	272	64	1	171	272	514	12,136	58,805
46. 8. 3~5	台風19号	70	364	554	1,093	70	364	554	1,093	5,783	23,999	

(注) 死者及び行方不明者の合計が50人以上のもの。
de

ORIGINAL PAGE OF POOR QUALITY

Table III-20-2. Record of Storm and Flood Damage Since 1946 (2) - continuation from Table III-20-1.

Key to Table III-20-2.

a: Date of Disaster	b: Kind of Disaster	c: Personal Damage
d: Dead	e: Missing	f: Injured
g: Damage of Houses	h: Totally Destroyed (Washed Away)	
i: Partially Destroyed	j: Flood over the Floor	
k: Flood under the floor		l: No. of persons
m: number of houses		
n: 9/26/59	o: 5/24/60	p: 6/24/61
q: 10/25/62	r: 1/63	s: 7/17/64
t: 9/10/65	u: 6/27/66	w: 7/8/67
x: 8/17/68	y: 6/24/69	z: 7/16/71
aa: 8/3/71	ab: Typhoon 15	ac: Typhoon 18
ad: Tidal Wave - Chile	Earthquake	ae: Typhoon 16
af: Coal Mine Accident	ag: flood/land-slide	ah: Typhoon 13
ai: flood/land-slide	aj: flood/land-slide	ak: snow damage
al: flood/land-slide	am: Typhoon 20	an: Typhoons 23, 24 and 25
ao: Typhoon 4	aq: flood/land-slide	ar: flood/land-slide
as: flood/land-slide	at: flood	au: flood/land-slide
av: Typhoon 19	aw: flood/Typhoon 25	ax: flood/Typhoons 6,7 & 9
ay: flood/Typhoon 20	az: flood/Typhoon 8	
ba: flood/Typhoon 17	bb: 7/3/72	bc: 5/29, 74
bd: 9/8/76	be: Remarks: Only the disasters which caused 50 or more persons to be dead or missing are listed in this table.	

Key to Table III-21.

a: Year	b: Classification	c: No. of Fires
d: Total	e: Buildings	f: Forest
g: Area Destroyed by Fires		h: Buildings (m ²)
i: Forest (a)	j: Dead and Injured	k: Dead
l: Injured	m: No. of Families that Incurred Fire Damage	
n: Total	o: No. of Persons who Incurred Fired Damage	
p: Damage (Thousand Yen)		q: Total Amount
r: Building Damage	s: Forest Damage	

t: Years are counted by Showa.

Showa	A.D.
20	1945
25	1950
30	1955
35	1960
40	1965
45	1970
50	1975
55	1980

LEADING PAGE BLANK NOT FROM

区分	発生年月日	地域又は地震名	規模 マグニチュード	家屋損失				死者 (人)	損失家 屋100 戸につ いての 死者数 (人)
				全壊 (戸)	全壊 (戸)	流出 (戸)	計 (戸)		
全壊及び流出家屋のみで全壊家屋がない場合	大正13.1.15	丹沢山塊	7.2	1,298			1,298	19	1.48
	昭和5.6.26	北伊豆地震	7.0	2,165			2,165	272	12.56
	6.6.21	西埼玉地震	7.0	206			206	16	7.77
	10.7.11	静岡市付近	6.3	814			814	9	2.43
	14.5.1	鹿半島	7.0	585			585	27	4.62
	20.1.3	三河地震	7.1	12,142			12,142	1,961	16.15
	24.7.26	赤松市付近	6.4	873			873	8	0.92
	36.2.2	赤松市付近	5.2	220			220	5	2.27
	37.1.30	宮城県北部	6.5	369			369	3	0.81
	39.6.16	新潟県新潟市	7.5	1,960			1,960	26	1.33
43.2.21	えびの地震	5.7	368			368	3	0.82	
台	ac	計		21,000			21,000	2,349	11.19
全壊家屋及び流出家屋のある場合	大正14.5.23	兵庫県北部	7.0	1,295	2,180		3,475	428	12.32
	昭和2.3.7	北丹波地震	7.5	12,534	3,711		16,295	2,925	17.95
	18.9.10	鳥取地震	7.4	7,485	254		7,739	1,083	14.47
	23.6.28	福井地震	7.3	35,420	3,691		39,111	3,895	9.96
	43.5.16	1968年十勝沖地震	7.9	673	13		686	52	7.73
49.5.9	伊豆半島沖地震	6.9	134	5		139	30	21.58	
台	aw	計		57,591	9,854		67,445	8,413	12.47
流出家屋のある場合	大正12.9.1	関東大地震	7.9	12,266	47,123	668	57,657	10,207	24.82
	昭和8.3.3	三陸地震津波	8.3			4,917	4,917	3,008	61.18
	19.12.7	東南海地震	8.0	21,130		3,053	29,189	998	3.42
	21.7.21	南海地震	8.1	11,591	2,598	1,451	15,640	1,432	9.50
	27.3.4	十勝沖地震	8.1	815	14	91	920	33	3.64
35.5.23	チリ地震津波	8.5	1,571		1,259	2,830	139	4.91	
台	ak	計		165,373	49,730	11,645	226,748	19,417	23.57

(注) (1) 昭和51年版理科年表による家屋損失(非住家を含む。)100戸を標準とした。
 (2) ・津波による全壊
 (3) 死者数には行方不明者を含む。

Table III-22. Big Earthquakes Since the Great Earthquake Disaster in Kanto District. (Citation from Fire-Fighting White Paper, 1977)

ORIGINAL PAGE IS
OF POOR QUALITY

in their vicinity.

Japan is also located on the circum-Pacific Ring of Fire and is one of the world's most famous earthquake countries. Table III-22 lists major earthquakes since the time of the great earthquake disaster in the Kanto District. In great earthquake disasters, buildings, roads, bridges, water-supply/sewage pipes, gas pipes, etc. are destroyed all at the same time, and often followed by fires, or floods caused by damage to river banks or by tidal waves. Various kinds of disasters take place simultaneously and multiply damages. In particular, with recent trend of congestion in cities, a whole series of disasters, such as fires, etc., becomes more likely. In addition, a so-called state of panic may be responsible for further damage.

The Japanese government subsidizes the local communities so that they may prepare earthquake-proof water pools, portable engine pumps, electric power supply vehicles, heat-resisting rescue vehicles, etc. This aid is based on the Subsidizing Project for Preparation for Great Earthquake Disasters. However, this emergency equipment is not sufficient at present. Particularly, the transportation means which may be used in great disasters are not sufficiently developed. Such transportation means must carry the above-mentioned equipment, supplies or food and medicine, the injured, the refugees, etc., in an event of disaster. In January, 1978, the earthquake in the Izu District destroyed all ground transportation means in the area. The only transportation means available were ships and helicopters. Helicopters were able to reach the area only when weather conditions were good. Therefore, transportation was severely limited and many people were trapped in isolated disaster areas waiting for rescue ships.

Our next topic will be a comparison of helicopters to airships with regard to ability to perform the work of rescue and fire fighting. For example, the Tokyo Fire Department has five helicopters for fire fighting. The activity area of these helicopters covers a circle with a radius of 360 km and its center at Tokyo Heliport. The helicopters can reach Aogashima, one of the Seven Izu Islands, which is 362-km away, within one hour and a half. When helicopters fly to such an isolated island to fight a fire, however, two helicopters make a formation flight as a precautionary measure, in order to avoid a double disaster in the event. Besides fire fighting in isolated islands, other tasks during great disasters are required of helicopters. However, as shown in Table III-23, helicopters have certain disadvantages in that their flight distance and payload are limited, and they will fly only in good weather conditions in order to avoid a secondary disaster such as a crash. On the other hand, helicopters are significantly advantageous because of their excellent maneuvering performance. Therefore, if airships were provided with good maneuvering performance, they would be ideal rescue and fire-fighting aircraft. As a concrete means of realizing such a vehicle, a rescue LTA is proposed in this report. (See Section IV-6.) This LTA consists of an LTA mother ship and of a gondola which is suspended from it and may move freely in space by means of a jet engine which drives it. The LTA mother ship can be maintained on the fire's windward side where it is not affected by the upstream or the flame, while the suspended gondola approaches the fire

/124

Table III-23. Advantages and Disadvantages of Helicopters and LTA's as Means for Fire-Fighting.

		Helicopters		LTA's (with 10-ton. payload or more)	
		Advantages	Disadvantages	Advantages	Disadvantages
Traffic Conditions		not affected by other traffic.		not affected by other traffic.	
Ability of Carrying Water			Low Capacity	High Capacity	
Control of Water Pressure		possible by altitude control.		possible by altitude control.	
Air Fire	Cities		Almost impossible	possible with appropriate training.	
Fighting	Forest		Downwash**		
Ability	Tall Building	able to send fire fighters and rescue	Fire-fighting is impossible, D.W.**		Fire-fighting is almost impossible**
	Highway Fire	not affected by other traffic	Downwash**		
Command	Cities	able to make overall judgment*	Downwash**	able to send fire fighters and rescue	
Activity	Forest	difficult to find the spot.	cannot use loud-speaker due to rotor noise.	not affected by other traffic	
In the		dangerous to approach the fire.	Downwash**	able to make overall judgement.	
Air	Highway Fire	able to make overall judgment.	Downwash**	able to make overall judgement.	
		able to perceive situation and to send appropriate command.		able to perceive situation and to send appropriate command.	

- continued -

Cf. *The aircraft is not affected by the air stream caused by the fire if it is 800 to 1,200 feet in altitude.
 **The downwash of the helicopters may increase the fire.
 ***The fire-fighting activity is not possible by an airship itself, except for the initial procedures.

TABLE III-23 (Concluded) Advantages and Disadvantages of Helicopters and LTA's as Means for Fire-Fighting

Flight Distance & Time				relatively long can fly long time	
Monitoring Fire				Long time monitoring is possible	
Maneuvering Performance	Quick Response				Slow Response
Hovering Ability	Highly controllable				Accuracy is worse than helicopters
	Possible with relatively high accuracy.				Sensitive to Side Wind.
Effect of Wind			Impossible to fly with a wind speed more than 20 m/s.		Coercive to opposing wind, but sensitive to side wind.
Rescue Activity	Can reach the place in short time.		Flight time and distance are short. Cannot land near hospitals due to the noise. Cannot accommodate medical care equipment due to little payload.	Flight time and distance are long. Can land near hospitals without fear of noise. Can accommodate simple medical care equipment.	Lower speed than helicopters
Rescue Activity	Tall Buildings	Can make accurate judgment.	Cannot rescue many people at a time due to little payload.	Can make accurate judgment. Can rescue many people at a time. Can use as an air commander. owing to long flight ability.	
	Rescue in Disaster Area	Can reach the place in short time. Can make accurate judgment.	Large size crafts capable of mass transportation cause ferious downwash. Cannot transport large quantity of material or rescued people due to little payload.	Mass transportation is possible. Can rescue many people at a time. can make accurate judgment.	Lower speed than helicopters
Event of Great Earthquake	Can make accurate judgment of the overall situation.			Can make accurate judgment of the situation.	

Chapter IV. TECHNOLOGICAL STUDIES CONCERNING SPECIFIC
SELECTED HYBRID LTA

/127

CONTENTS

IV-1. Outline.....	164	(130)
IV-2. Determining the Required Performance Properties.....	169	(133)
IV-2-1. For Heavy Cargo Transport.....	170	(134)
(a) Payload.....	170	(134)
(b) Cruising Speed.....	171	(134)
(c) Distance of Cruise.....	174	(135)
IV-2-2. For Passenger Transportation.....	174	(136)
IV-3. Study of Rota-Ship Hybrid Airship.....	174	(136)
(Conceptualizing Design of a Helistat-Type Airship by Kawasaki Heavy Industry Company)		
IV-3-1. Study of Rota-Ship for Passenger Transportation.....	175	(136)
(a) Required Conditions of Design.....	175	(136)
(b) Outline.....	175	(136)
(c) Flight Control and Piloting Systems.....	181	(143)
(d) Structure.....	186	(146)
(e) Rotor System and Power Transmission System.....	193	(150)
IV-3-2. Study of Rota-Ship for Heavy Cargo Transportation.....	195	(152)
(a) Outline.....	195	(152)
(b) Piloting System and Piloting Method.....	200	(156)
(c) Structure.....	203	(156)
(d) Rotor System and Power Transmission System.....	203	(158)
(e) On-Board Equipment.....	204	(159)
(f) Mooring Means.....	204	(159)
(g) Considerations on Engine Malfunctions.....	205	(159)
IV-3-3. Problems of Mooring Sites, Sites for Landing and Take-Off, Etc.....	205	(159)
(a) Mooring Site and Mooring Means.....	205	(159)
(b) Take-Off and Landing Ground.....	205	(162)
(c) Training of On-Board and Ground Crew Members.....	215	(165)
IV-3-4. Development Plans and Development Expenses.....	217	(167)
(a) Development Plan.....	217	(167)
(b) Development Expenses.....	218	(168)
IV-3-5. Estimates of Operating Costs of Rota-Ship for Passenger Use.....	219	(168)
(a) Assumption for the Estimation.....	220	(168)
(b) Direct Operating Cost.....	221	(169)
(c) Total Operating Cost.....	223	(170)
IV-3-6. Estimates of Operating Costs of Rota-Ship for Heavy Cargo Transport.....	224	(171)
IV-4. Study of Skycrane Hybrid Airship.....	226	(174)
(Conceptualizing Design of an Aero Crane-Type Airship by Mitsubishi Heavy Industry)		
IV-4-1. Outline.....	226	(174)

/128

IV-4-2. Determining Skycrane Specifications.....	232	(178)	
(a) Specifications of Hull Structure.....	235	(181)	
(b) Specifications of Engines and Propellers.....	243	(188)	
IV-4-3. Performance Properties.....	246	(191)	
(a) Payload and Distance of Cruise.....	246	(191)	
(b) Ascending Performance.....	248	(192)	
(c) Sudden Failure of One Engine.....	248	(192)	
IV-4-4. Stability.....	248	(192)	
(a) Maximum g when Hovering	249	(192)	
(b) Dynamic Characteristics When Moving Forwardly.....	252	(194)	
(c) Damping and Control Power When Hovering.....	261	(203)	
IV-4-5. Reference Materials.....	263	(205)	
IV-4-6. Methods of Operation.....	264	(207)	
(a) Base for Skycranes.....	265	(207)	
(b) Forwarding to Cargo Handling Sites.....	267	(209)	
(c) Cargo Airlifting Work at Cargo Handling Sites...	267	(209)	
(d) Cargo Transportation.....	268	(209)	
(e) Unloading of Cargo at the Destination.....	268	(210)	
(f) Refill of Fuel and Helium, and Exchange of Crew Members.....	268	(210)	
(g) Necessary Space.....	268	(210)	
IV-4-7. Development Plan.....	269	(210)	
IV-4-8. Estimates of Operating Costs of Skycrane.....	270	(211)	
(a) Assumptions for the Estimation	270	(211)	
(b) Necessary Expenses for Ten Years.....	270	(211)	
(c) Estimates Made by Asahi Helicopter Company.....	274	(214)	<u>/129</u>
IV-5. Estimates of Operating Properties of Megalifter Type Aircraft.....	277	(217)	
IV-5-1. Resistance.....	277	(217)	
IV-5-2. Lift Resistance Characteristics.....	282	(220)	
IV-5-3. Performance Properties.....	282	(220)	
IV-6. Technical Studies of Automatic Operating Devices of Suspended Gondolas.....	287	(224)	
IV-6-1. Suspended Maneuvering Module (SMM).....	287	(224)	
IV-6-2. Study of Concept of Suspended Maneuvering System with SMM Suspended by LT.....	291	(228)	

IV-1. Outline.

/130

As a result of the studies on "needs" (social requirements) in Chapter III, requirements regarding technological developments, or technological possibilities (we call "seeds"), are summarized as follows:

(A) Concerning Heavy Cargo Transport.

Is there any means of air transportation which has payload over the limit of the presently used helicopters and which can carry about 100 tons of heavy cargo?

In addition, it is important for such a means to possess VTOL ability.

In such transportation of heavy cargo, the cargo will usually be suspended outside the aircraft. Therefore, the transportation speed must be very low. When considering the present heavy cargo ground transportation means which move at a speed of about 5 km/hour (which is the speed at which men walk), it will be desirable to limit the speed of heavy cargo air transportation means to about 30 km/hour - 60 km/hour. In other words, high speed is not required; on the contrary, low speed transportation is preferred for the safety reasons. However, the transportation speed by usual truck may be desirable rather than the ultra-low speed, 5 km/hour, at which the present heavy cargo ground transportation means are operated.

It is very possible that very narrow valleys of deep mountains will be transportation routes. Therefore, the LTA bodies preferably have as compact size as possible.

When loading and unloading cargoes, hovering in the air is required. In such cases, hovering by means of self-equipped power is not necessarily required, but the aircraft may hover with the aid of mooring ropes. The required time of cruise is several hours. Preferably, the duration of cruise should be long enough to transport heavy cargoes directly from the nearest harbor to the sites, even to the sites which are located in the deepest mountainous areas in the Japan Islands. It can be said that the maximum width of the Japan Islands is less than 300 km and the width is less than 200 km in most places. Therefore, the required transportation distance is about half of the above width if the cargoes are transported in straight courses. Namely, a straight line distance of 100 km to 150 km, or a flight distance of 200 km to 300 km, will be satisfactory.

According to the evaluation criteria which were introduced in Section I-2-1, "Basic Functions of Aircraft," in Chapter I, the characteristics required of heavy cargo air transportation means are shown as follows:

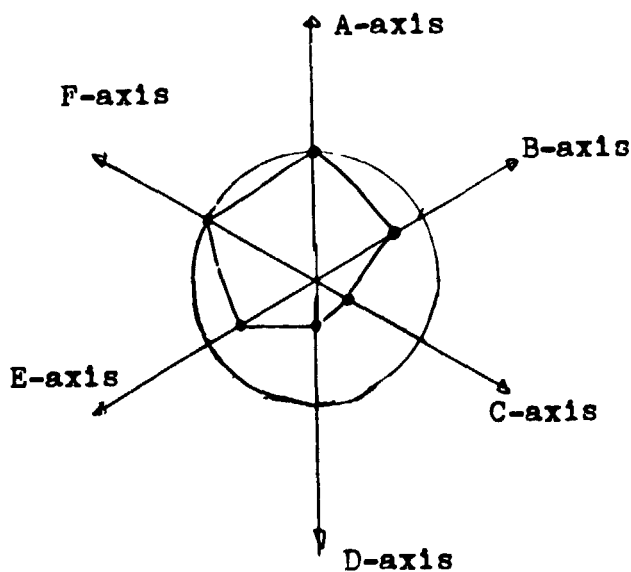

Fig. IV-1.

- A-axis: Vertical movement ability must be excellent. /131
- B-axis: Mass transportation ability must be excellent. The aircraft can carry up to about 100 tons, preferably.
- C-axis: Duration of cruise may be at a common level, i.e. several hours.
- D-axis: Distance of cruise can be short
- E-axis: High speed property is not required.
- F-axis: Maneuvering performance may be at a common level.

(B) For Passenger Transportation

As transportation means connecting isolated islands or large cities, a line distance is expected to be around 300 km. At the present stage, there is no appropriate mass transportation means for such short lines.

The passenger demand for those short lines, however, is increasing significantly not only in Japan but also as a world-wide trend, as shown in Chapter III.

It may be concluded that the required property of aircraft for such short lines is not high speed. In other words, the high speed, 500 km/hour to 700 km/hour, of the presently used fixed-wing aircraft is hardly advantageous in those short lines. For example, the US-11 used in the approximately 130-km Fukuoka-Tsushima Line has a cruising speed of 475 km/hour and a flight distance of 2,330 km while the actual flight time in this line is only 40 minutes, implying that the practical speed for passengers is less than 200 km/hour.

The required properties for air transportation means used in those short lines are also VTOL ability and excellent mass transportation ability.

An attempt at providing the presently used fixed-wing aircraft with mass transportation ability, however, requires high speed of the aircraft. Thus, the disadvantage that a long runway is necessary is inevitable.

Particularly in lines connecting isolated islands, air transportation means are competing with ships. While air transportation in inland lines is required to compete with other ground transportation means such as railroads and motor vehicles, requirement of high speed of the air transportation in such lines connecting isolated islands is not very strict. For example, even though their speed is as low as that of buses, 80 km/hour, the Jetfoil used in the Sado Line has proved a remarkable success.

The functions desired of the aircraft for short-distance lines, which have been described above, can be schematically shown in Fig. IV-2.

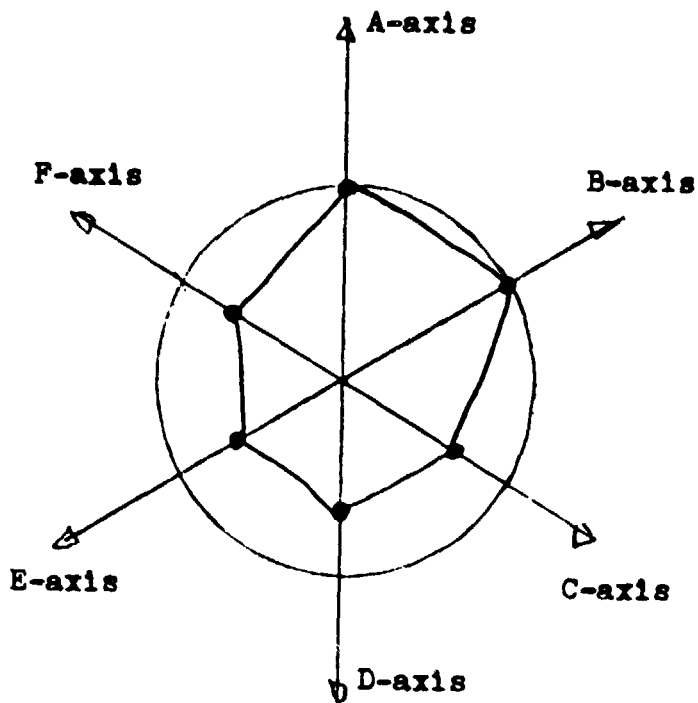

Fig. IV-2.

A-axis: Vertical movement /132
ability must be excellent. The direct connection of the regional centers is preferred. VTOL ability is desired.

B-axis: Mass transportation ability equal to that of ships is required. Namely, 100 to several hundreds of passengers.

C-axis: Flight time does not have to be very long, since the line distances are short.

D-axis: Flight distance does not have to be very long, since the line distances are short.

E-axis: Speed of buses and trucks is required in over-the-sea lines, while speed slightly higher than that of railroads is required in inland lines.

F-axis: Maneuvering performance should be excellent.

From the viewpoints which have been described above, we have selected Aero Crane and Helistat type LTA's among other hybrid LTA's for our studies on the technical possibilities of LTA's.

On studying technical possibilities, when an appropriate helicopter or a fixed-wing aircraft is provided by a domestic maker, the combination of a LTA with such aircraft or a part of it was considered first.

Helicopters or fixed-wing aircraft which have already been developed in Japan are naturally for their own purposes. Therefore, the combination of those aircraft with other machines, such as LTA's, which are the objects of this survey study, is not primarily aimed at, and will be inferior to optimally designed hybrid LTA's.

Nevertheless, without sufficient prospect of future hybrid LTA's, design of new engine and the new rotors connected to it will not be an appropriate object of pursuit in the first stage.

Therefore, it is for this reason that the utilization of the already developed machines and systems was first taken into consideration for studies on technical possibilities. This characterization of the approach can be clearly seen in the works by the group which has studied Helistat type aircraft under the leadership of Mr. Yosniori Sakai (Kawasaki Heavy Industry).

On the other hand, the group headed by Mr. Yoshiki Oka (Mitsubishi Heavy Industry) has studied Aero Crane type aircraft. This type of aircraft is so novel that it is very hard to find any presently available machines which can be applied to this type of hybrid LTA's.

Helistat or Aero Crane is the name of the group which is now engaged in the development of such an LTA in the U.S.A. Therefore, these are not appropriate names for referring to types of aircraft.

/133

In particular, the coordinators of this survey study were strongly of the opinion that appropriate names should be given to the LTA's which would be developed in Japan. Thus, it was decided to call them: the Helistat type LTA "Rota Ship" and the Aero Crane type LTA "Sky Crane."

Several studies on Megalifter type airships were done as preliminary work prepared for the future main work of the survey study and are included in this report. When the regular cargo transportation enters the era of mass transportation, i.e. reaches the level of several millions of tons per year, giant airships will be required. (Cf. "Survey Study on LTA Aircraft," Japan Association for the Promotion of Mechanical Industries, September, 1975.) In such a case, the Megalifter type of airships, which are hybrid of airships and fixed-wing aircraft, will attract much attention. In this survey study, preliminary work was done in preparation for such a future case.

Automatic piloting means for suspended gondolas, as means of air rescue in the event of disasters, were studied for the following reasons:

Apparently the maneuvering performance of balloons or airships is significantly inferior. Improving the maneuvering performance of the gondola portion instead of improving the overall maneuvering performance of the LTA is one way of compensating for this disadvantage. According to this idea, an LTA which has satisfactory maneuvering properties will be produced.

Whether an LTA is hybridized or not, means for improving the maneuvering performance of the LTA force it to be economically inferior.

According to the idea of the high maneuvering performance gondola, the low price of the conventional type airships will be preserved. Thus a moderately priced, highly maneuverable LTA can be expected.

If this type of suspended gondola can be developed in combination with the conventional type of airships, they may be used with various types of hybrid LTA's.

Based on the viewpoints mentioned above, suspended gondolas were selected for the fourth object of our study.

IV-2. Determining the Required Performance Properties.

For Helistat type airships, the required performance properties were studied only in the case of its being used as a cargo transportation means.

In each case, the survey on the demand in the market was done prior to the determination of the required performance properties. The result of this survey has been described in detail in Chapter III.

Even though determination of the required performance properties based on the market demand is being attempted, these properties cannot be pinpointed exactly since they are connected with new fields which did not exist in the past. It is a common procedure in such a case to start with a study of the "seeds" (technical possibilities) and then to examine the "needs" which correspond to them, and afterwards to start again with a study of the "seeds" based on the results obtained and so forth, repeating this routine several times in order to converge on the most desirable result. This kind of work is probably typical in the development of a new device such as this. /134

For this reason, it should be clearly understood that the required performance properties as set forth in this report must be regarded only as the first result of this kind of work.

IV-2-1. For Heavy Cargo Transport.

LTA's for heavy cargo transportation requiring greater payload will be described first.

(a) Payload.

The sector of heavy cargo transportation which faces difficulties at present is that which carries cargoes heavier than 20 tons, i.e. the limit, as determined by the Rule for Limiting Vehicle Weights. Even though over 1,000-ton cargoes are transported at present, such cargoes consist mainly of equipment which is transported to and installed in plants in sea-side industrial areas.

Conditions in heavy cargo transportation in inland areas have been getting worse year by year due to road conditions (the sharp increase in traffic), the reduction of railroad services, the protests of roadside residents against such transportation, etc. Such heavy cargo transportation is required in connection with large scale construction works such as dam construction. In such cases, civil engineering equipment must be moved in first, followed by heavy equipment for plants such as penstocks. The payload required for this kind of transportation ranges from 20 to 100 tons.

The number of over-20-ton trailers possessed by N. Transportation Company, which specializes in heavy cargo transportation, is listed in Table IV-1. Table IV-2 shows a common example of the number and the kinds of trailers which are delivered to the construction site of a hydroelectric power plant. Based on the above data, the initial target of the payload was set at around 30-70 tons.



Table IV-1. Trailers.

	Number of Units
Type 500 TG Trailer	1
Type 350 TG/TS Trailer (Type 500, Decomposed)	1
Type 250 TG/TS Trailer (Type 500, Decomposed)	1
300 TG/TS Trailer	1
210 TG/TS Trailer	1
160 TG/TS Trailer	1
150 TG/TS Trailer	2
150 TL Trailer	1
120 TG Trailer	1
100 TG Trailer	1
80 TL Trailer	2
75 TL Trailer	1
70 TG Trailer	1
70 TG/TL Trailer	2
60 TL Trailer	5
45 TL Trailer	1
40 TL Trailer	11
30 TL Trailer	10
25 TL Trailer	24
20 TL Trailer and Others	140

Table IV-2.

	Number of Units
70-ton Trailer	1
40-ton Trailer	4
30-ton Trailer	2
20-ton Trailer	2
Total	9

(b) Cruisir Speed

/135

Table IV-3 shows the performance properties of the tractors which pull the trailers which were described above.

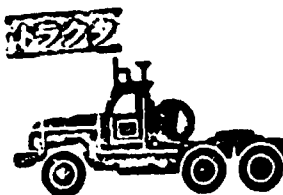

Table IV-3. Tractors

Number of Units

W400 Class (Fifth Wheel Load: 40 tons) and heavier classes.....	12
W250 Class (Fifth Wheel Load: 25 tons).....	2
W150 Class (Fifth Wheel Load: 15 tons).....	14
Others (Except High-Speed Container Vehicles).....	175

Specifications of Tractors (Standard Specifications)

Name of Model	Hitachi HTH 50	Mitsubishi W400	Mitsubishi W250	Mitsubishi W150
Name of Manufacturer	Hitachi	Mitsubishi Heavy Industry	Mitsubishi Heavy Industry	Mitsubishi Heavy Industry
Number of Passengers	3	3	3	3
Vehicle Weight (kg)	23,900	17,565	12,480	9,695
Fifth Wheel Load (kg)	53,500	40,000	25,000	15,000
Distribution of Load over Axles (front) (kg)	12,780	8,620	6,280	4,400
Distribution of Load over Axles (rear) (kg)	11,120	8,945	6,200	5,295
Distribution of Load over Axles (front) (kg)	20,910	14,585	7,590	5,120
Distribution of Load over Axles (rear) (kg)	56,655	46,145	30,055	19,740
Total Length (mm)	8,485	7,665	6,925	6,680
Total Width (mm)	3,370	2,940	2,890	2,490

Total Height (mm)	3,350	2,945	2,830	2,720
Minimum Rotation Radius (m)	10	10	10	10
Maximum Engine Output (PS/rpm)	330/ 2,000	250/ 2,200	250/ 2,200	250/ 2,200
Maximum Engine Torque (km-m/rpm)	120/ 1,400	89/ 1,200	89/ 1,200	89/ 1,200
Maximum Speed (Without Trailer) (km/hour)	40	70	52	44
Transporta- tion Speed with loaded trailer (km/hour)	5	5	25	25
Tires size/ Number)	14.00-24 20PR/12	12.00-20 16PR/18	12.00-20 16PR/18	11.00-20 14 PR/18
Winch Cap- acity (kg)	8,000	18,000	13,000	8,000

According to this table, the transportation speed when tracting loaded trailers is 5 to 25 km/hour. Therefore, the speed requirement is not at all severe. On the contrary, such low speed may cause aircraft to be economically inefficient if they use conventionally used aircraft engines. As a common requirement of transportation means, however, higher speed is desirable. Thus, a speed of 50 km/hour was selected as the initial target. However, considering anticipated head wind speed and performance properties of engines and rotors equipped to LTA's, a speed of over 50 km/hour will be inevitable.

(c) Distance of Cruise.

Since the freight car transportation on the railroads has become difficult, it is very probable that heavy cargoes will be transported to the nearest harbor by sea instead of railroads when the trailer transportation on the roads around the construction sites is replaced by air transportation. In this case, considering the transportation from the nearest harbor to the deepest mountain areas, half of the cross distance of the Japan Islands will be the required distance of transportation. This distance is calculated as ranging from 150 km to 200 km. When loading and unloading cargoes, the aircraft must hover for a long time. In addition, considering emergency cases, such as one in which the aircraft cannot reach its destination, the initial target for the cruising distance was determined to be 150 to 300 km.

Other than the performance properties specified above, the initial target must include craft price, economic efficiency, various specifications of the aircraft, etc. In this conceptualizing design of a future aircraft, however, the target was given only for payload, cruising speed and distance of cruise, as an initial trial.

/136

Our intention is to obtain an answer which will result from a conceptualizing design given only those performance properties, and to extract more specific requirements from potential users by showing them that answer.

IV-2-2. For Passenger Transportation.

The requirements of passenger transportation were estimated with reference to those of STOL short-distance airplanes which are now required in Japan.

The requirements are the ability to use about 900 m of runway length, to be as economical and as low-noise as the YS-11, 120 to 150 passengers, and about 300 km cruising distance.

IV-3. Study of Rota-Ship Hybrid Airship.

Conceptualizing designs have been made for rota-ship hybrid airships of two types, one for passenger transportation connecting isolated islands and one for heavy cargo transportation. Rota-ship airships are combinations of conventional cigar-shaped non-rigid airships filled with helium gas and of rotor lift helicopters. They are provided both with the ability to carry heavy cargoes and to hover. The idea of this type of aircraft is basically that of improving the disadvantages of helicopters (high fuel costs, etc.), while providing helicopters with the ability to carry cargoes which are heavier than the present limit. In this study, the scope is limited to the rotor systems of helicopters which are now used in

Japan. The technical problems in the development of rota-ships, the estimates of the development costs and possible development schedules will be described.

IV-3-1. Study of Rota-ship for Passenger Transportation.

(a) Required Conditions of Design.

- (1) 4 units of rotor systems of the helicopter, BK-117, which is now in the development process in a Japan-Germany corporative project are equipped. (See IV-12 for the photographic view.)
- (2) The payload is 120 passengers (10.56 tons).
- (3) The cruising distance is 300 km with a margin of an additional 300 km and 10 minutes of hovering, considering the head winds of 20 knots (10.3 m/s).
- (4) The operational ascent limit is 10,000 feet (3048 m).
- (5) The airship body selected is of the non-rigid type, for cost reduction purposes.

(b) Outline.

A three-side drawing of a passenger rota-ship is shown in Fig. IV-3. This rota-ship has a total length of 80m, maximum hull diameter of 27 m, a total width of 52 m and a total height of 30.5 m. The fineness ratio selected is 3, since the ship has a non-rigid hull structure. The front portion of the hull has an ellipsoid shape while the rear portion has a paraboloid shape. The hull volume is about 27,300 m³. The ballonnet volume is about 26% of the hull volume, being determined by the operational ascent limit, 10,000 feet.

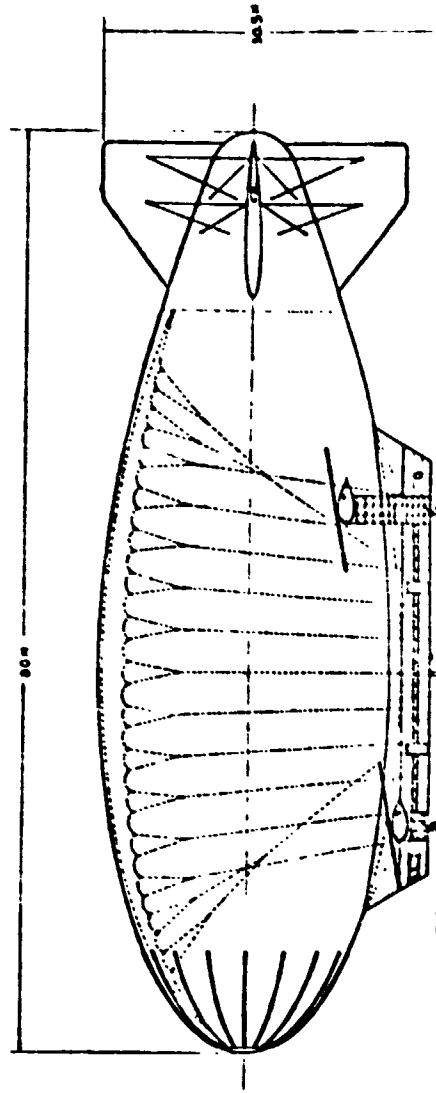
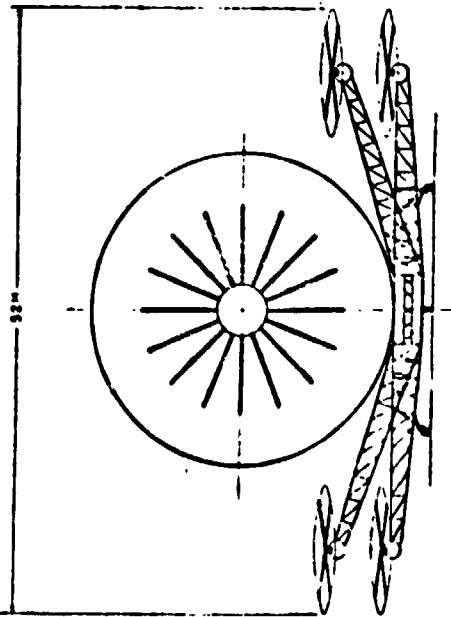
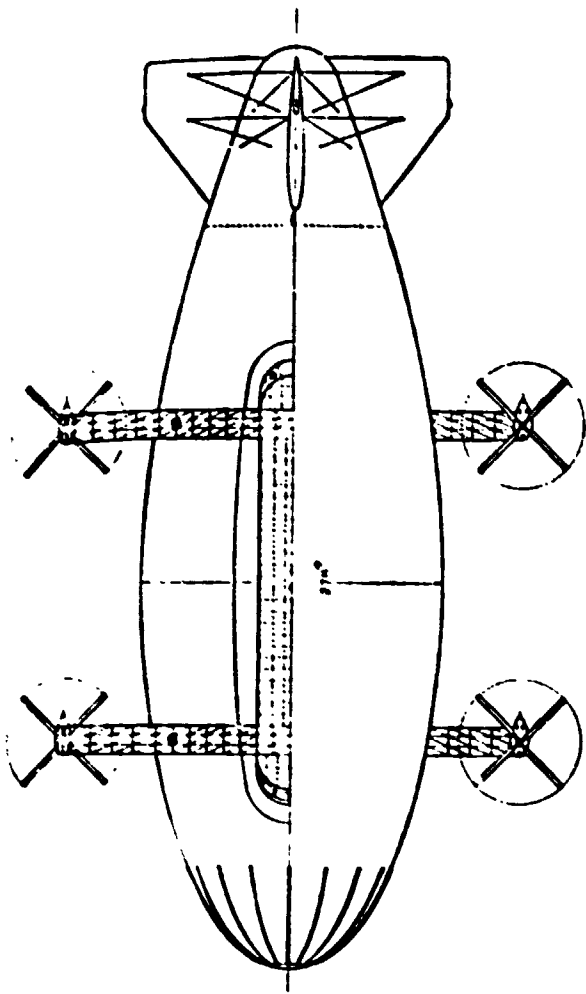

Fig. N-3 Three-Sided Drawing of Rota-Ship for Passenger Transportation.

The gross weight of 32 tons is divided into 21.44 tons of buoyancy and 10.56 tons of rotor lift. The maximum rotor lift is 12.7 tons so that about 2.1 tons of rotor lift can be used for maneuvering and controlling the airship.

There are five crew members -- two pilots, one on-board mechanic and two stewardesses.

The basic size data and performance properties were calculated based on the computing procedure shown in Fig. IV-4. The weight data were statistical or computed data. The data about the rotors were those of helicopter Bk-117. The major specification is listed in Table IV-4, while the fundamental performance properties are shown in Figs. IV-5 and IV-6.

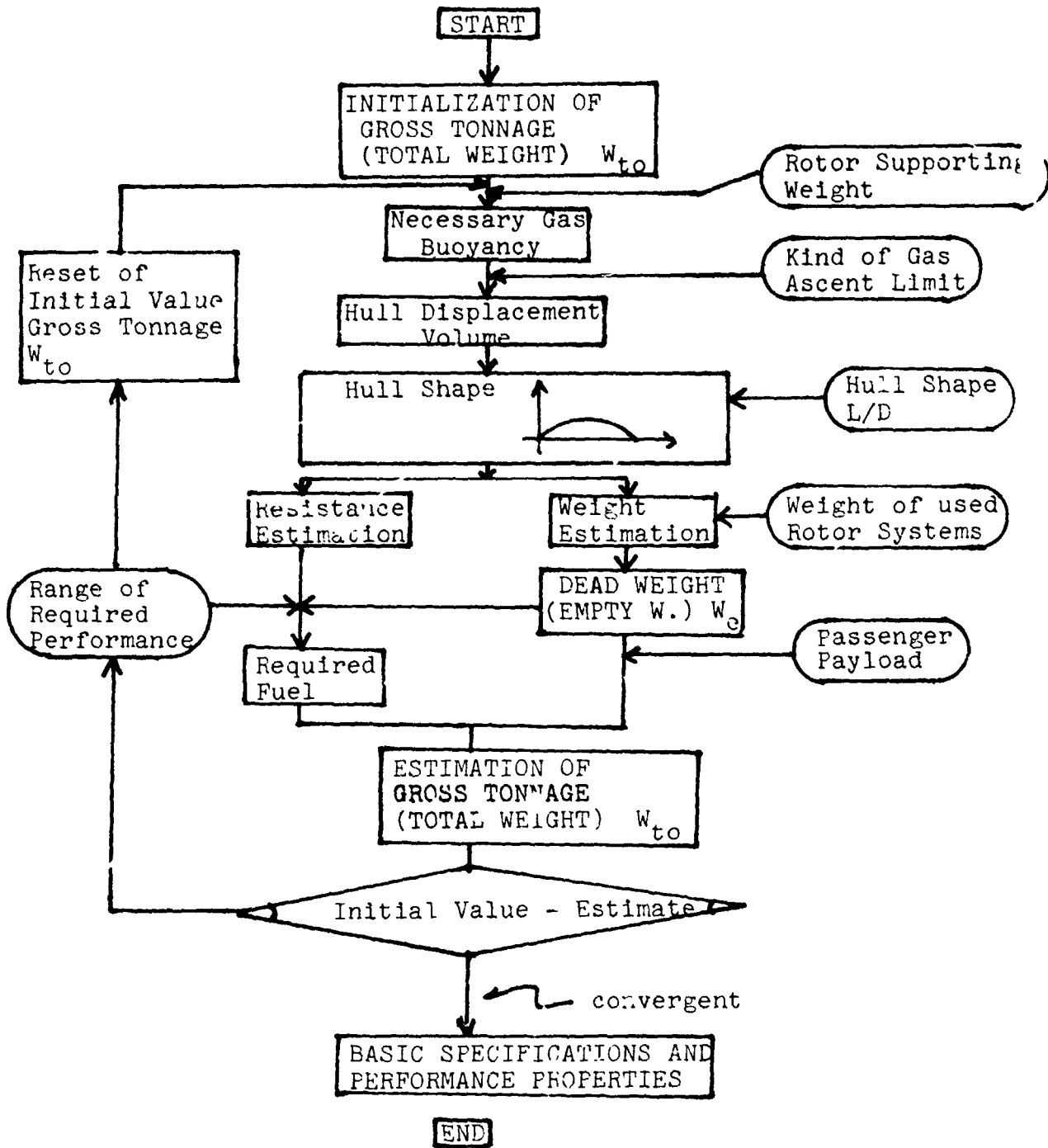

Fig. IV-4. Determination of Hull Specifications.

Basic Size Data:	Total Length:	80m
	Total Width:	52m
	Total Height:	30m
Equipped Power Means:	Engines:	Laikaming LTS101-650B+1 600 SHF x 8 units
	Rotors:	4 units of 11-m diameter, four-blade rotors.
Specifications of the Hull:	Hull Length (L):	80m
	Maximum Width (D):	27m
	Fineness Ratio (L/D):	3
	Hull Displacement Volume:	about 27,300m ³
	Ballonet Volume:	about 7,100m ³
	Gondola Size:	2.5m (H) x 6m (W) x 25m (L)
	Number of Seats:	120
Weight Data:	Dead Weight:	17,300 kg
	Passengers	400 kg
	Fuel Carried	3,740 kg
	Payload	10,560 kg
	Gross Weight:	32,000 kg
	Gas Buoyancy: (At Sea Level)	about 21,500 kg

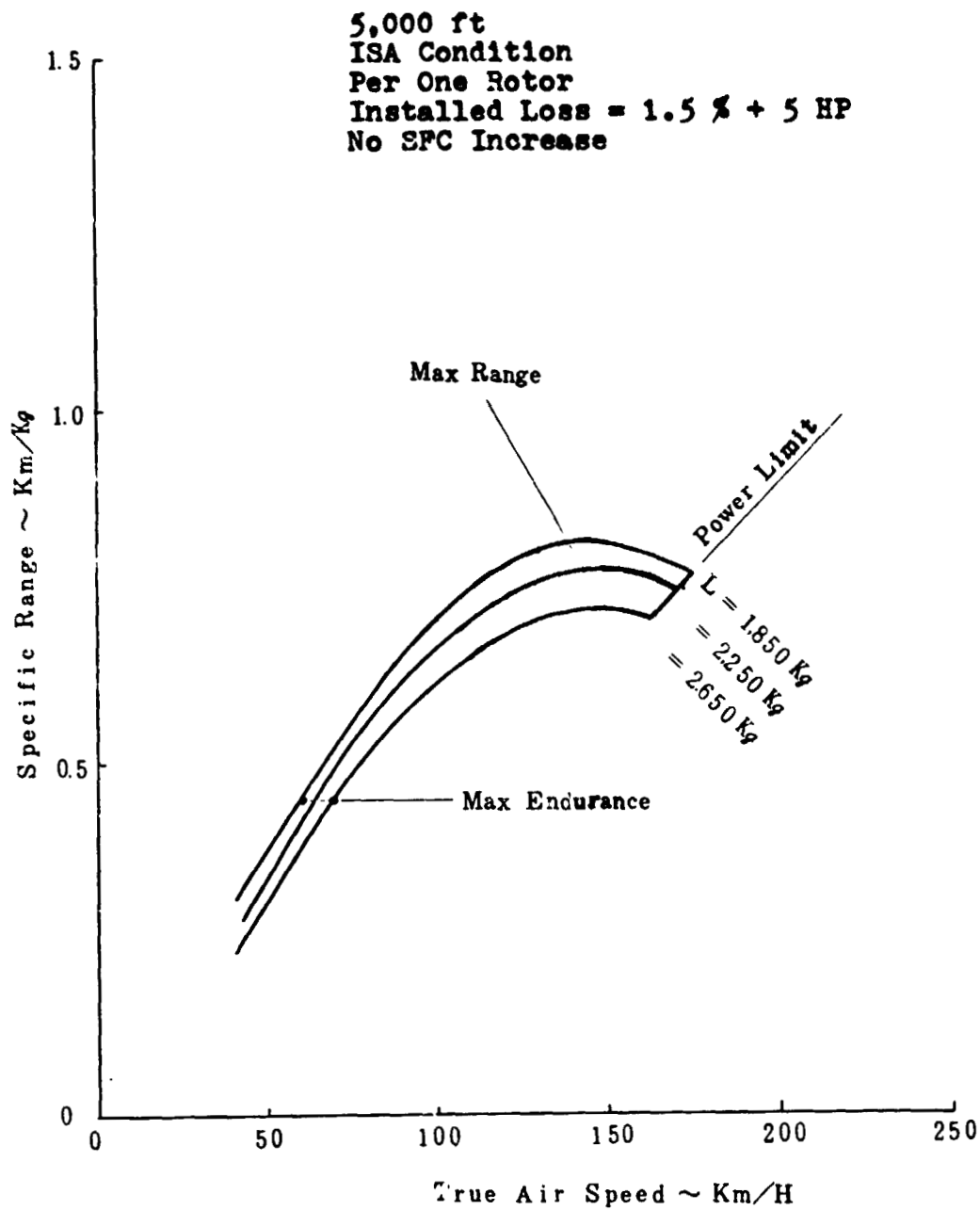
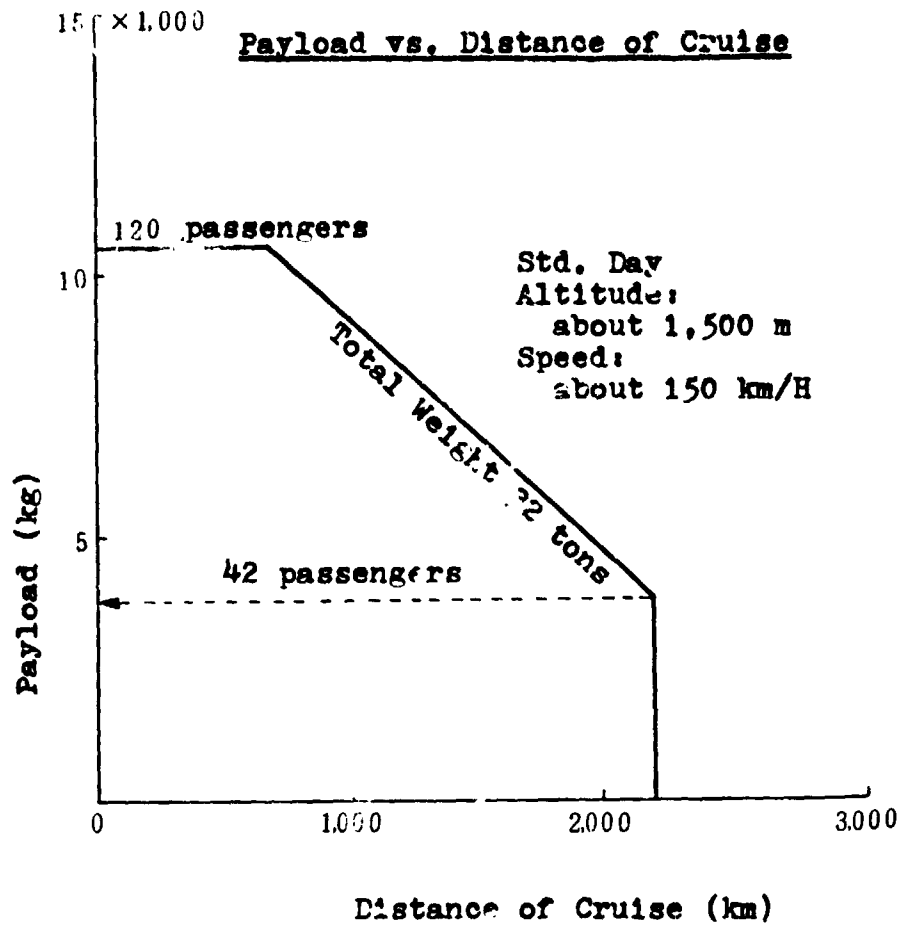

Fig. IV-5. Flight Endurance Characteristics.
 (Estimated)



Maximum Speed:	about 170 km/hour
Cruising Speed:	about 150 km/hour
(Cruising Altitude:	about 1,500 m)
Ascent Limit:	about 3,000 m
Distance of Cruise:	about 700km
Duration of Cruise:	about 6 hours

(c) Flight Control and Piloting Systems.

/143

The flight control means are shown in Fig. IV-7.

A 上昇, 降下

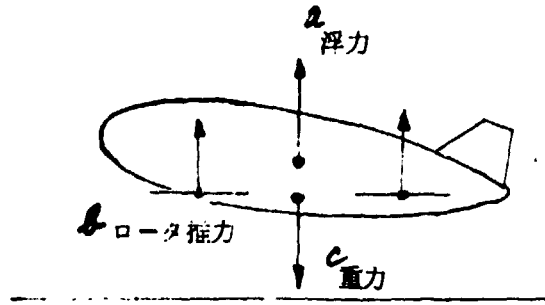

ORIGINAL PAGE IS OF POOR QUALITY

B 前進飛行

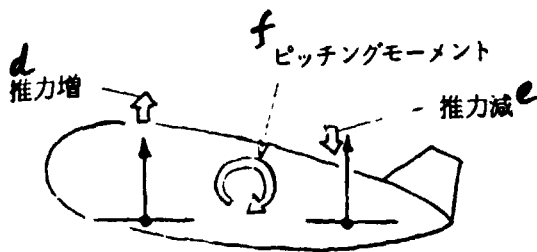
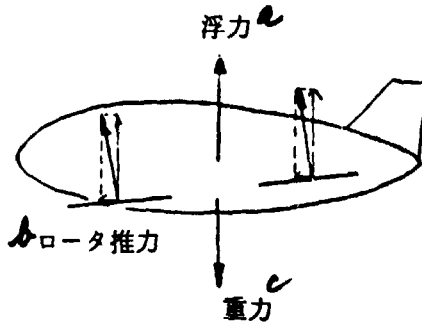

C ピッチ・コントロール

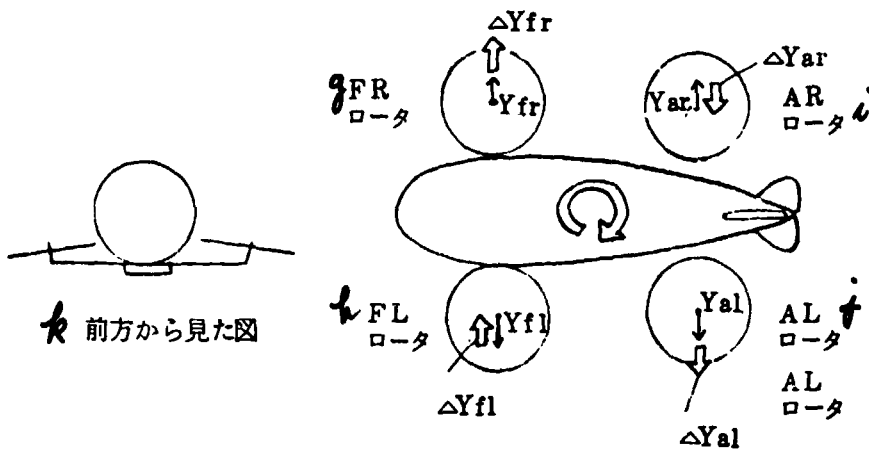

D ヨー・コントロール

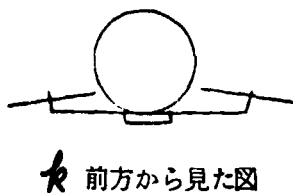

k 前方から見た図

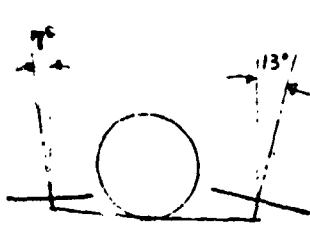

m 前方から見た前部ロータ

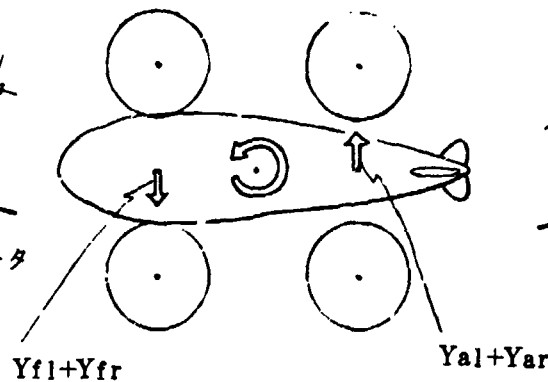

E 反トルク機構



l 後方から見た後部ロータ

Fig. IV-7. Piloting Method.

Key to Fig. IV-7.

A: Ascent and Descent
C: Pitch Control
E: Counter-Torque Mechanism

B: Forward Flight
D: Yaw Control

a: Buoyancy
c: Gravity
e: Decrease of Thrust
g: FR Rotor
i: AR Rotor
k: Front View

b: Rotor Thrust
d: Increase in Thrust
f: Pitching Moment
h: FL Rotor
 : AL Rotor
l: Rear View (rear rotors)

In order to improve maneuvering performance when taking off and landing, and to improve stability when hovering in winds, this ship is provided with four units of rotors, one on each front side and one on each rear side, which control the direction and the posture of the ship by changing the thrust and its direction.

/144

When the ship ascends or descends, the thrust of the four rotors are increased or decreased simultaneously. The rotors provide a margin of thrust which is about 10% of the gross weight when hovering with full load.

The forward movement of the ship results from the rotor thrust horizontal component which is created by either inclining the ship body or flapping the rotors by means of cyclic pitch control.

The pitch and yo control of the ship body is obtained by adjusting the thrust of the four rotors individually. For the yo control, the thrust of each rotor is adjusted, as well as the rotor thrust horizontal component which is varied via the cyclic pitch control.

The anti-torque moment is created by providing slightly different angles at which the rotors are attached to the ship body.

The four rotors must be capable of individual thrust control and of direction and intensity control in response to each steering movement, such as ascending, forward move, etc. For this purpose, each rotor is equipped with a control-rose-and mixing box which converts each command from a pilot to the appropriate steering operation of corrective pitch and cyclic pitch control of each rotor. The command is transmitted from this box to each rotor by means of lay-by-wire mechanisms, so that the ship is controlled appropriately.

As described above, the propelling and the steering of the ship are done mainly by varying the rotor thrust. If greater propelling or steering power is desired, the rotors may be attached to the ship body by gimbal means.

Discussions of the stability and control properties of the rota-ship are not included in this study. However, according to the calculation results of dynamic stability/control computer simulation which was done by NASA, based on the wind tunnel data of Helistat in Phase II, it may be concluded that desirable dynamic stability/control properties can be obtained by appropriate automatic control means for the four rotors. Fig IV-8 shows an example of hovering response to a sharp edge sudden cross wind of 50 ft/sec. In this example, the lateral displacement is about 0.55 ft (17 cm).

In the future, a computer simulation/analysis program for analyzing the dynamic stability/control characteristics based on the wind tunnel data must be developed, together with a design based on further studies of fly-by-wire control means and automatic control devices.

A-3

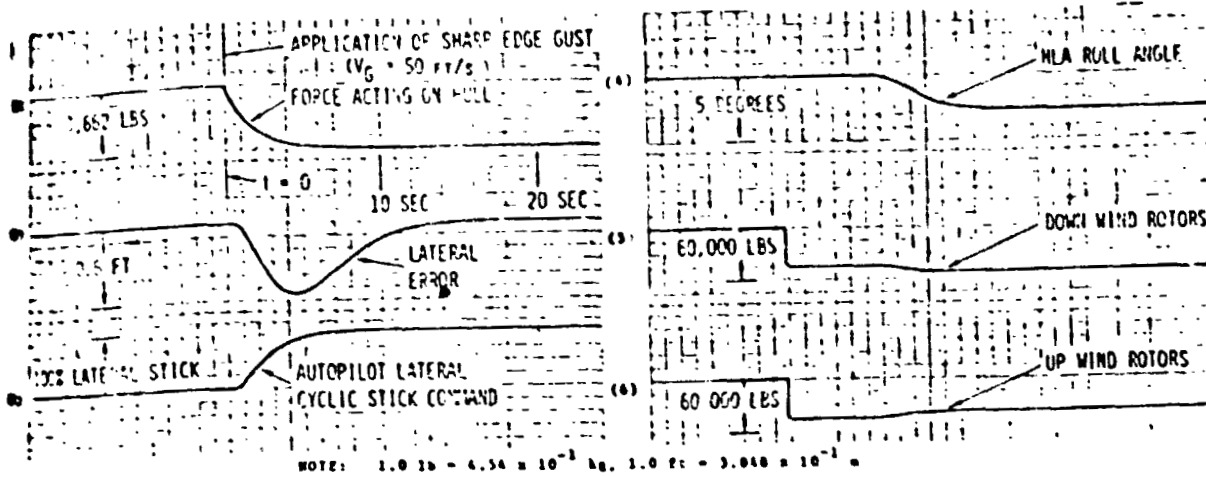

Precision Hovering Response at Design Gross Weight
 - Six DOF Computer Simulation Results For A
 Continuous Sharp Edge Lateral Gust

ORIGINAL PAGE IS
 OF POOR QUALITY

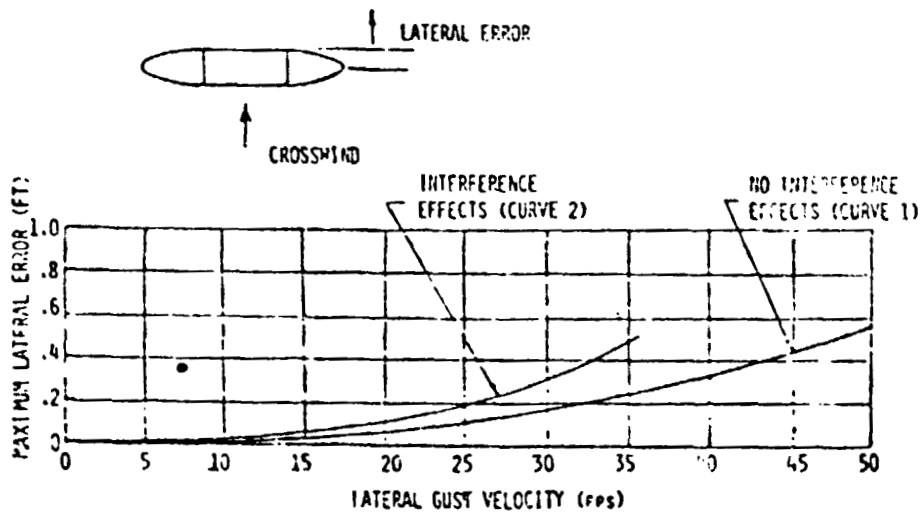

NOTE: 1.0 ft = 3.048 x 10^-1 m, 1.0 ft/s = 3.048 x 10^-1 m/s

Peak Lateral Precision Hovering Response at Design
 Gross Weight - Six DOF Computer Simulation Results
 for a Continuous Sharp Edge Lateral Gust

Fig. IV-8. Hovering Response to Side Wind.

The main construction of a rota-ship consists of rotor supporting structures, a non-rigid hull structure including ballonets and helium gas, a gondola structure including passenger cabinets and a cockpit, suspension structures which support the rotors and the gondola, and leg and tail structures.

Although load transfer mechanisms should be studied so that the elasticity and the strength of the structures may be safe under all the possible load conditions which are anticipated, an initial idea of them can be gathered from the following discussion.

Rotor Supporting Structure: With a sudden wind increase rate of 2 and a safety factor of 2, the design final rotor load is $3.2 \times 2 \times 2 = 12.8$ tons, considering the case where an upward sudden wind was received when the rotors put out the maximum thrust. The maximum bending moment at the root portions is 244 t-m ($= 12.8 \text{ t} \times 17.7 \text{ m}$). In the case where pipe materials of aluminum alloy 6061 are formed in truss to constitute the beams, as shown in Fig. IV-9, the diameter of the pipe material should be 60 to 90 cm and should have excellent long-column buckling strength. In addition, in order to avoid resonance with the oscillation exciting force of the rotors, the design should be done so that the lowest order natural frequency is higher than the required frequency, 30.7 Hz.

Non-rigid Hull Structure: The inner pressure of the hull must be sufficiently high within the load limitation in order to avoid crease formation. The film material load is 40 kg/cm if the film material load limitation is about 10 kg/cm and the safety factor is 4. If the film is composed of tedra film for weather resistance, two layers of mylar as gas barriers and shear resisting materials, and dacron cloth as main materials rendering strength is used. Those materials are stuck together to form a multi-layer structure. Such material with a weight of about 300 g and a tensile strength of about 40 kg/cm may be produced in Japan. If kebura cloth, a new material, is used as the main strength-bearing material, the 40-kg/cm strength multi-layer material can be reduced to be about 200 g/m² in weight and the film material, including gore adhesive portion and reinforcement portion, will be about 300 g/m².

The creep of the film material and the gore adhesive portion is another design target. Hence, further studies of film materials must be done in the development of rota-ship.

Gondola Structure: A frame type of structure (shown in Fig. IV-10) which is usually used for fuselages has been selected. The size is 6-m width, 25-m length and 2.5-m height so that 120 passengers may be accommodated in six-column, 20-row seats with sufficient room. This gondola structure is attached to the front and the rear rotor supporting structures so that a H-shaped structure is formed. (See Fig. IV-11.)

Suspension Structure: About 60 joint portions are provided for the H-shaped structure in order to distribute the approximately 60 tons of the load over the hull when the safety factor is 2. At each joint portion, two ropes are sharing about 500 kg/rope of the load. Each rope distributes half of the load to the upper portion of the hull. As an additional load, a bending force and torque is applied resulting from the rotor thrust. These factors were not associated with conventional airships, and hence, further studies must be done to analyze the suspension rope system, in order to avoid undesirable transformation of the hull resulting from the overall load applied to it.

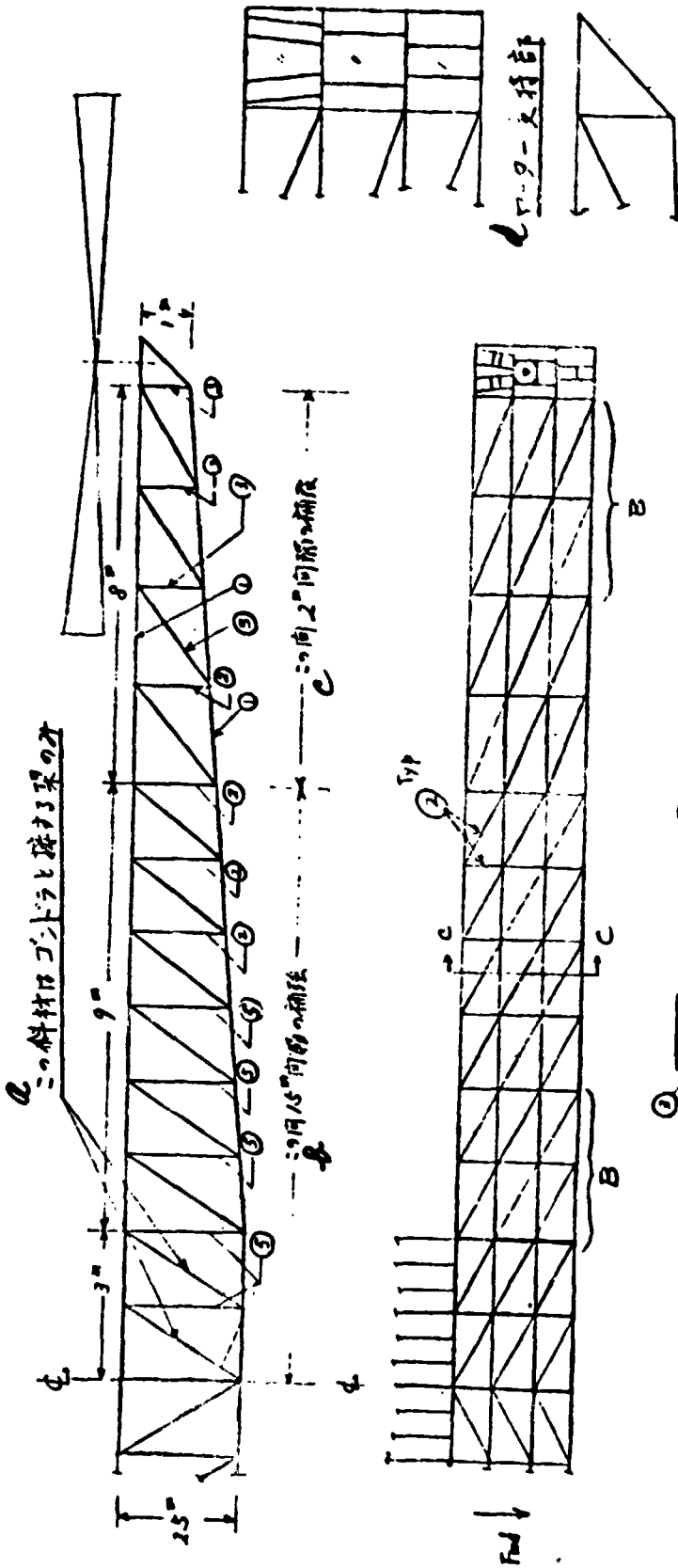

材料 6061 E=6960 kg/cm² f_t=210 kg/cm²
 F₁₀=27 kg/cm², F₁₁=25 kg/cm²

No.	材種	A (cm ²)	S (cm ³)	Z (cm)	I (cm ⁴)	W (kg/m)
1	671.35	7912	86.4	19.4	3.03	2.82
2	66.528	573	21.2	7.9	2.04	1.52
3	105.23	4203	17.8	5.57	2.06	1.26
4	605.32	5760	21.7	7.04	2.03	1.73
5	763.22	6412	23.7	11.5	2.60	1.94
6	871.32	8136	22.8	17.7	3.04	2.17

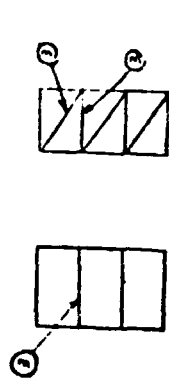

Section C-C B
 一般断面 主要断面

Fig. IV-9. Rotor Supporting Structures.

ORIGINAL PAGE IS
 OF POOR QUALITY

Key to Fig. IV-9.

a: These diagonal materials are used only in the beams which are adjacent to the gondola.

b: This portion has 15-m interval reinforcement.

c: This portion has 2-m interval reinforcement.

d: Rotor Supporting Portion

f: Material 6061

g: Size

h: Common Cross Section

i: Cross Section of Rib of Main Portions

Fig. IV-10. Gondola Structure.

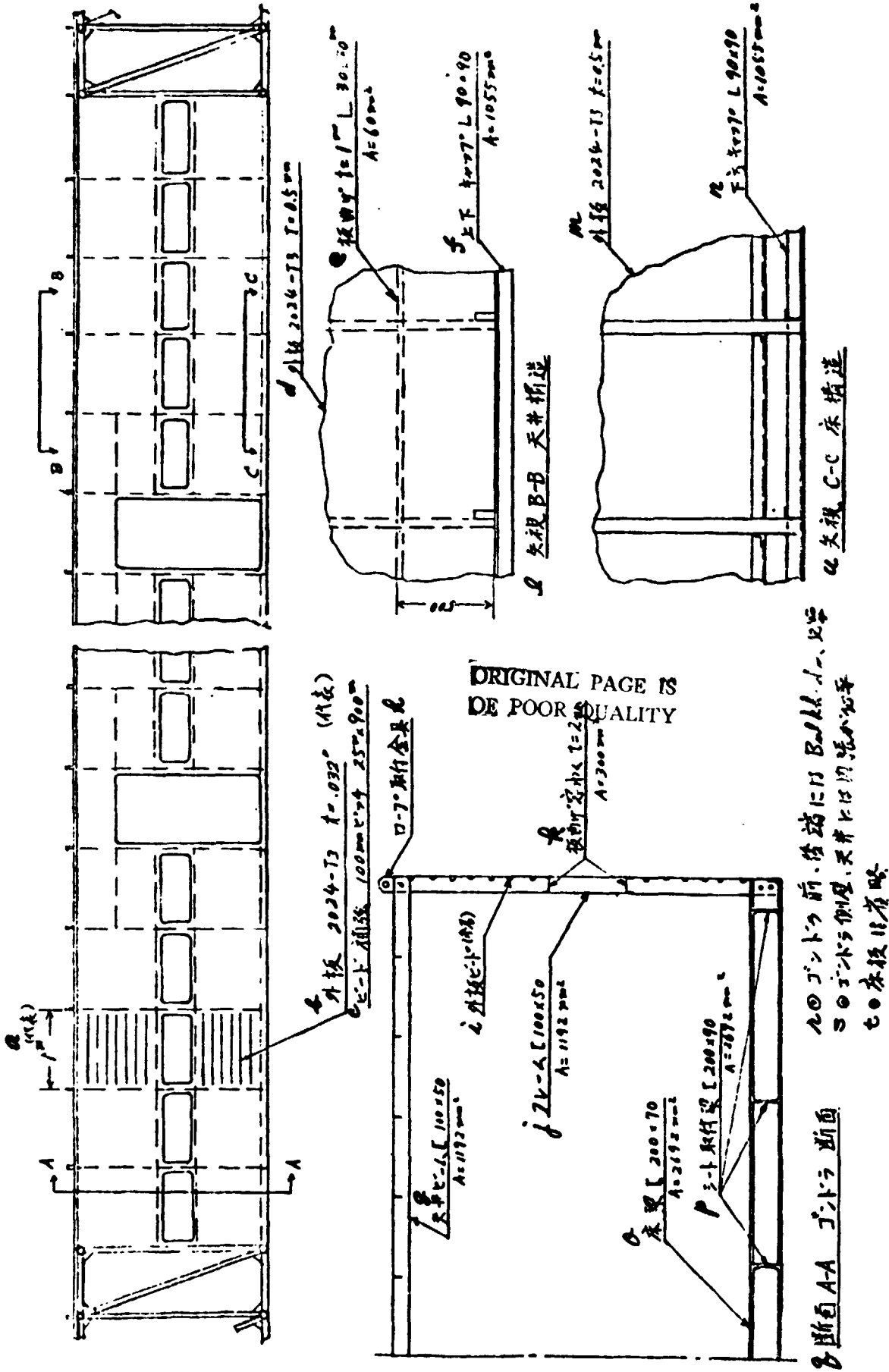

Key to Fig. IV-10

- a: Representative
- b: Outer Plate 2024-T3, $t=.032''$ (Representative)
- c: Bead Reinforcement
- d: Outer Plate
- e: Bent Plate
- f: Upper and Lower Caps
- g: Ceiling Beam
- h: Rope Fitting
- i: Outer Plate Bead (For Reference)
- j: Frame
- k: Wind Frame with Bent Plate
- l: B-B Direction, Ceiling Structure
- m: Outer Plate
- n: Upper and Lower Caps
- o: Floor Beam
- p: Seat Fitting Beams
- q: A-A Section, Cross Section of Gondola
- r: Bulkheads are necessary at the front and the rear ends of the gondola.
- s: The inner cover is necessary on the side wall and the ceiling of the gondola.
- t: The floor plates are not shown.
- u: C-C Direction, Floor Structure.

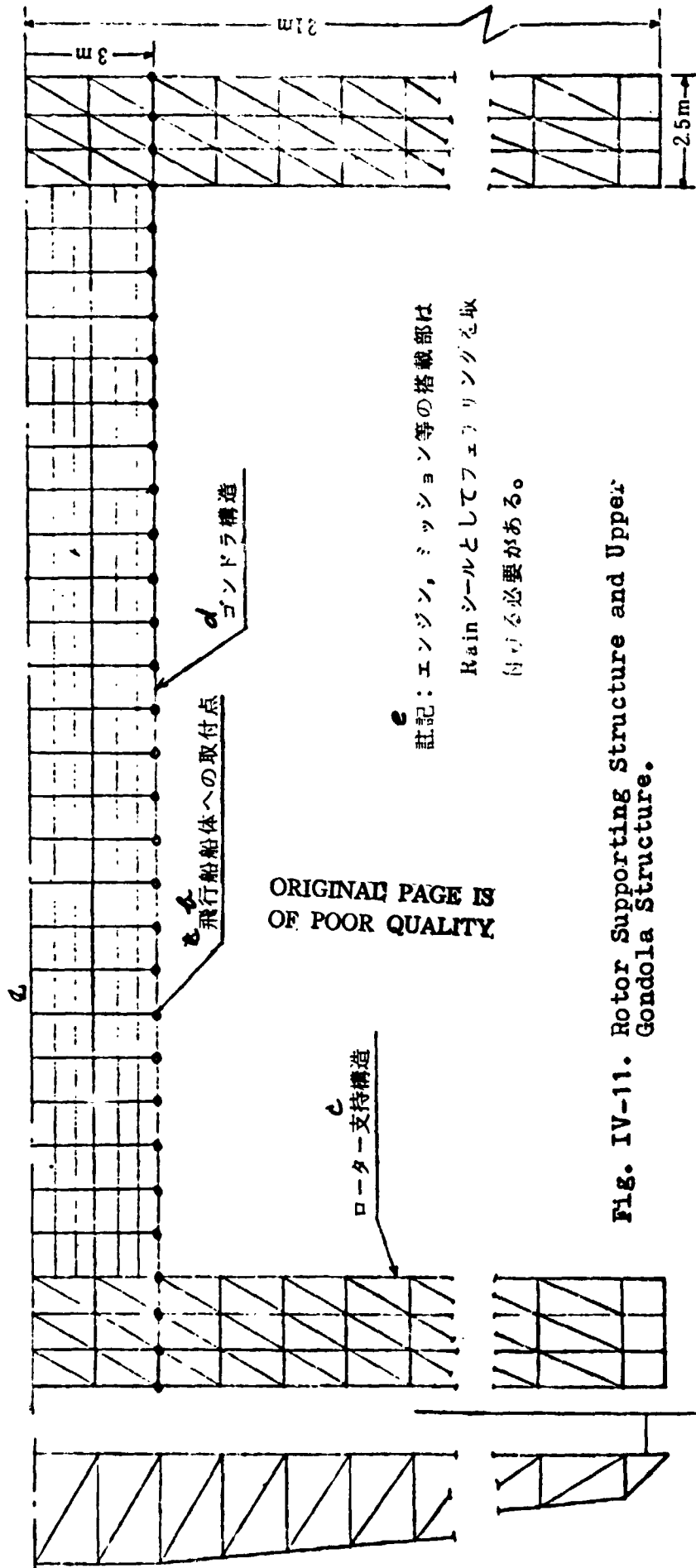
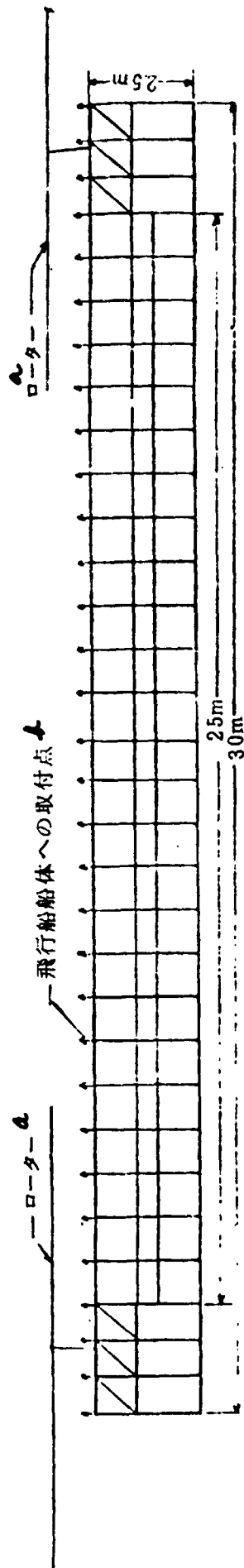

註記：エンジン、ミッション等の搭載部は
Rain シールとしてフェラリリングを取
付ける必要がある。

ORIGINAL PAGE IS
OF POOR QUALITY.

Fig. IV-11. Rotor Supporting Structure and Upper Gondola Structure.

Key to Fig. IV-11.

- a: Rotor
- b: The Points Attached to the Hull.
- c: Rotor Supporting Structure.
- d: Gondola Structure
- e: Remark: The portion mounting engines and transmission means must be provided with fair-rings for rain sealing.

(e) Rotor System and Power Transmission System.

/150

Each of the four rotor systems is a unit consisting of engines, a gear box and a rotor of the helicopter, BK-117. These systems are manipulated by fly-by-wire means. Each rotor is driven by two engines and provides about 3.2 tons of thrust in the upward direction and about 1 ton in the downward direction. The thrust is controlled by corrective pitch control means.

The specifications of the rotor system and the engine are described in the following:

Rotor System (one Unit):

Diameter:	11.0 m
Blade Code	0.31 m
Number of Blades	4
Rotation Speed	383 RPM
Maximum Thrust	3.17 tons (upward)
	1 ton (downward)

Engine:

Name:	Laika Ming
Number of Units per rotor	2
Output per Unit	600 HP (Take Off Power: 30 mi.)
	512 HP (Max. Cont. Power)
Rotation	6000 RPM

The schematic diagram of the rotor system is shown in Fig. IV-12.



川崎重工とMBB社が共同開発に着手したBK117の想像図

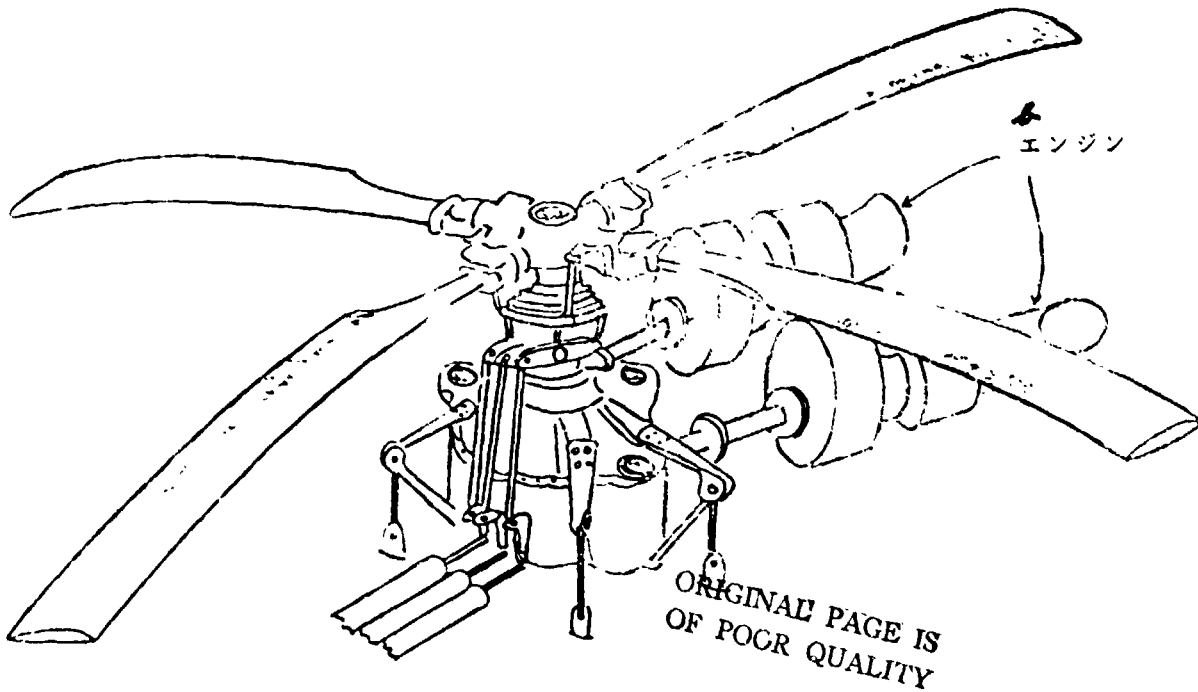

重量 (kg)	ロータシステム	235
	コントロールシステム	61
	トランスミッション&マウント	175
	インプットシャフト	5
	エンジン (2基)	240
	冷却システム	34
	フレーム	70

★ 計 820 kg / 1ロータシステム

Fig. IV-12. Rotor System of BK-117

Key to Fig. IV-12.

- a: Imaginary View BK-117 Which is Under Corporative Development by Kawasaki Heavy Industry and MBB Company
- b: Engines
- c: Weight (kg)
- d: Rotor System
- e: Control System
- f: Transmission and Mount
- g: Input Shaft
- h: Engine (Two Units)
- i: Cooling System
- j: Frame
- k: Total: 820 kg/rotor-system

IV-3-2. Study of Rota-Ship for Heavy Cargo Transportation.

/152

Concerning the rota-ship which uses the rotors of the helicopters used in Japan and has the the ability of hovering and carrying heavy cargo heavier than 20 tons, two alternatives have been proposed besides the rota-ship described in this section. One of these alternatives is the rota-ship which has four units of tandem rotors (KV-107 helicopter, See Fig III-24 in Section III-2.) all rotating around axes attached to the hull so that each rotor provides a local forward speed component. This proposal was made for the purpose of fuel conservation when hovering. Such a rota-ship was considered advantageous in heavy cargo transportation to an isolated mountainous area. Rotation of the rotor system is carried out by inclining the rotor surfaces by means of cyclic pitch control. (rotation speed: 7.72 rpm) The necessary power can be reduced by about 10%. However, fuel conservation will probably not be able to easily overcome the increase of the weight resulting from the additional rotor system rotation mechanisms, and hence, this alternative was discarded.

The other alternative is the rotor-ship with three units of tandem rotors. This ship has a payload of 20 tons and was proposed for the purpose of the cost reduction. However, it is difficult to obtain appropriate positioning of three units of tandem rotors. When they are combined with a cigar-shaped hull, two units will be placed on both sides and one in front or rear portion. This structure requires a long longitudinal rotor supporting structure which causes weight increase and makes the suspension structure connected to the hull very complicated. Thus, this alternative was also discarded.

(a) Outline.

The rota-ship described in this section has four units of tandem rotor systems, two of them being placed on both sides of a front rotor supporting structure and the other two being placed on both sides of a rear rotor supporting structure. The rotor supporting structures form an H-shape together with cargo compartment structure.

The fundamental specifications of this ship are as follows:

- (1) Four units of rotor systems (with maximum lift of about 40 tons) of KV-107IIA support a payload of 30 tons and 6.7 tons of fuel. The remaining lift is used for the posture control of the airship.
- (2) 30 tons of cargoes are loaded and unloaded by means of winches with which the airship is equipped.
- (3) The airship has the cruising ability of 5,000-feet (1,500-m) cruising altitude, 100-km/hour cruising speed, 200 km-cruising distance and a 1-hour hovering ability.
- (4) There are four crew members -- two pilots, one on-board mechanic and one operator of a loading/unloading system.

Based on the above fundamental specifications, the rota-ship shown in the three-side drawing in Fig. IV-13 was designed. It is a scaled-up version of the rota-ship for passenger transportation and has a size of 90-m total length, 30-m maximum hull diameter and 37-m total height. The hull volume is $35,800 \text{ m}^3$ and the ballonnet volume is $6,250 \text{ m}^3$ (about 17.5% of the hull), providing the operational altitude limit of 6,000 feet (2,000 m).

31.1 tons out of the 68-ton gross tonnage is supported by the gas buoyancy and the remaining 36.7 tons is supported by the rotors.

The main specifications are listed in Table IV-5 while the main performance properties are shown in Fig. IV-14. The amount of fuel consumed during a one-hour hovering is about 40 % of the total fuel carried, 6.7 tons. If this amount of fuel is used for flight, the airship can fly for about 330 km.

The payload vs. flight distance characteristics are shown in Fig IV-14.

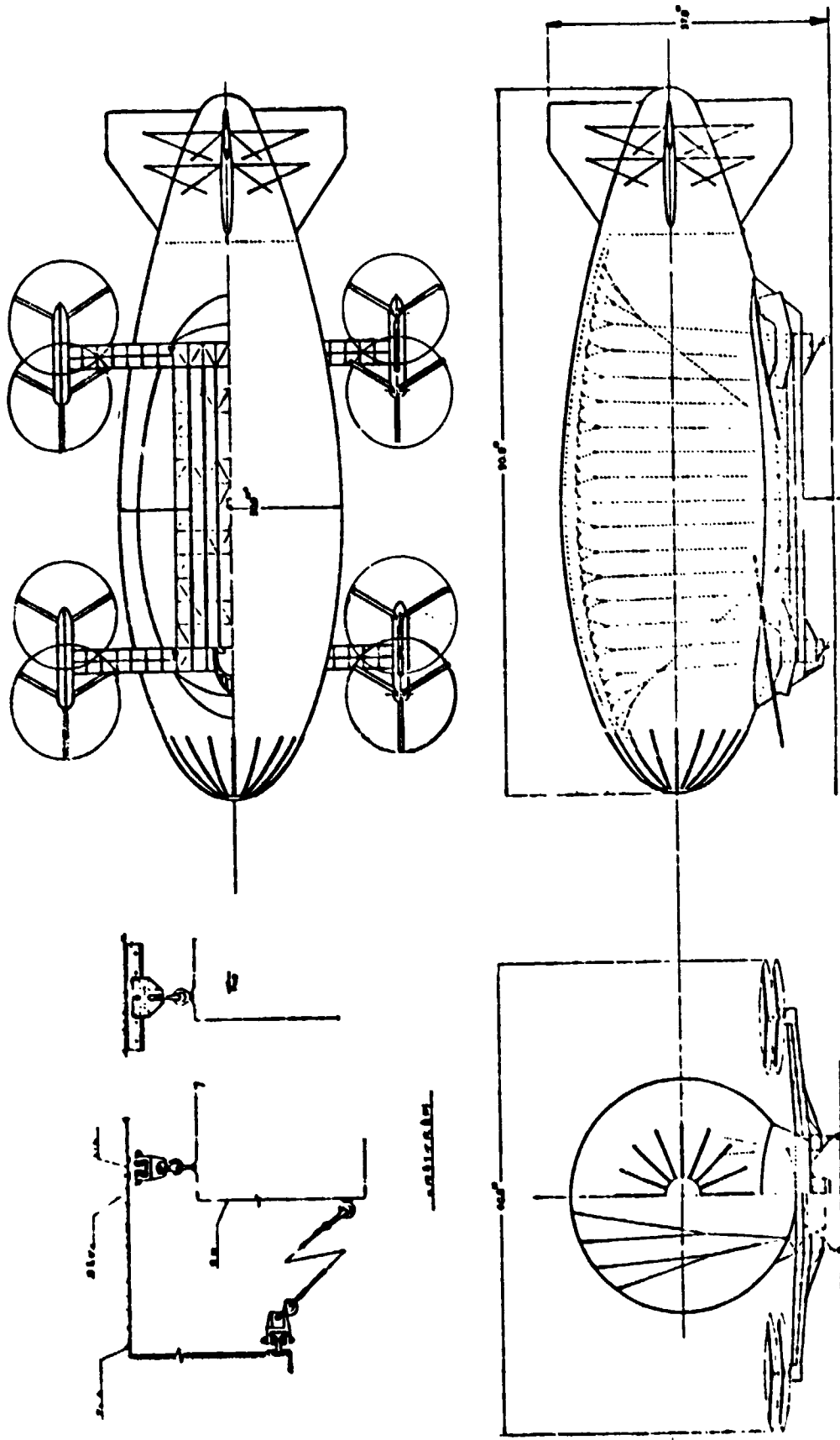

Fig. IV-13. Three-Sided Drawing of Cargo IFA.

Table IV-5. Main Specifications.

/154

Main Size Data:	Total Width	60 m
	Total Length	90 m
	Total Height	37 m
Power Equipment:	Engine:	GE-T58-IHI
	Power:	1,400 SHP x 8 units
	Rotors:	3 blades x 15.2 m
Hull Specifications:	Hull Length:	90 m
	Maximum Diameter:	30 m
	Fineness Ratio:	3
	Hull Displacement	
	Volume:	35,800 m ³
	Ballonet Volume:	6,250 m ³
Weight:	Dead Weight:	31,100 kg
	Fuel Weight:	6,700 kg
	Payload:	30,000 kg
	Gross Weight:	68,000 kg
	Gas Buoyancy:	37,000 kg
		(at Sea Level)
Crew Members:	four persons	

Cruising Speed: 100 km/hour
 (Cruising Altitude: 1,500 m)
 Ascent Limit: 2,000 m
 Distance of Cruise: 300 m (Without hovering)
 Duration of Cruise: about 3 hours

/155

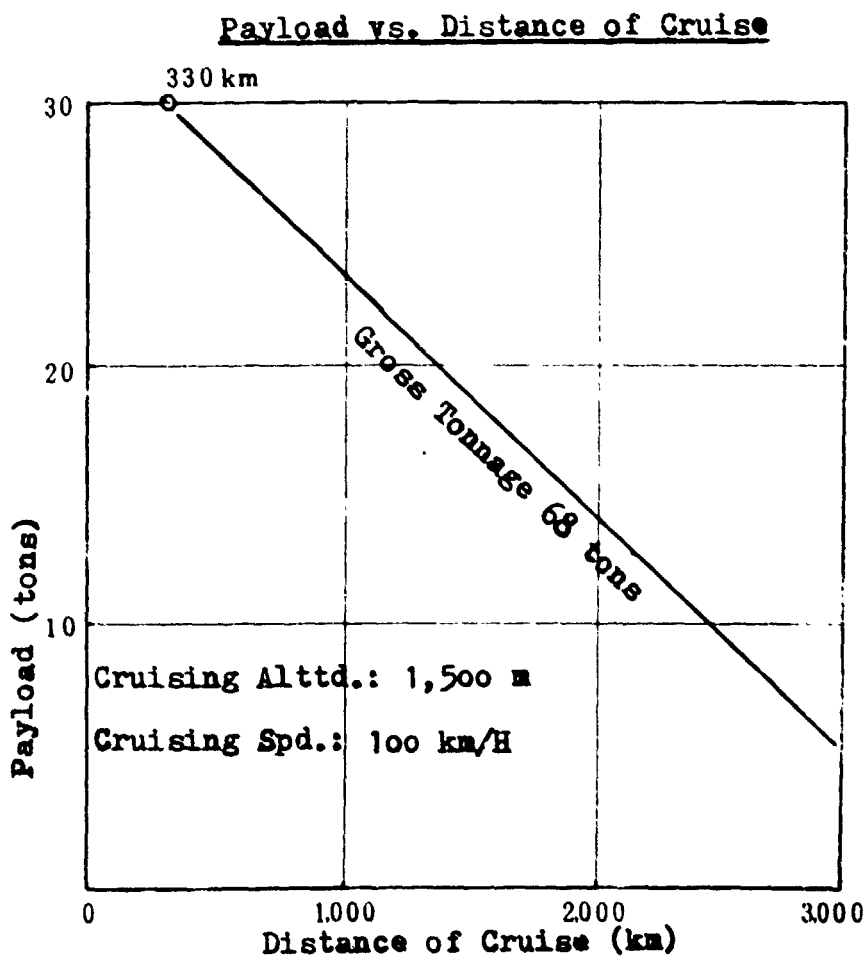

Fig. IV-14. Basic Performance Property.
(Cargo Transportation)

(1) Construction (See Fig. IV-15)

The piloting of the ship is done by varying the intensity and the direction of the thrust by each of the four rotor systems. The thrust of each rotor and its direction are controlled by swash plates. The vertical movement of swash plates adjusts the thrust while the direction of the thrust is varied by inclining the swash plates.

The swash plates are connected to the piloting means by push-pull rods, bell cranks, cables and electrical lines.

In addition, in order to compensate for the lateral inclination resulting from the variation of the flight speed, speed trim means are provided, by which longitudinal inclination of the swash plates are automatically controlled in response to the change in speed.

(2) Piloting Method.

In the following, a total system of a KV-107 II helicopter including front and rear rotors is denoted by "one unit of rotor system."

(i) Ascending and Descending.

The ship ascends or descends by means of simultaneous increase or decrease of the thrust by the four units of the rotor systems.

(ii) Forward and Backward Flight and Pitch Control.

When flying forward, the thrust by the two units of the rotor systems in the front portion is decreased by means of pitch control while the thrust by the two rear units of the rotor systems is increased so that the airship body is inclined forward. Backward flight requires the same procedure in the opposite direction.

(iii) Flight in Side Direction and Roll Control.

These are performed by adjusting the thrust of the right and the left units of the rotor systems.

(iv) Yaw Control

The thrust of the two front units of the rotor systems is directed in the same direction (right or left), while the thrust of the two rear units is directed in the opposite direction.

(v) Hovering around a Fixed Position.

When hovering around a fixed point for cargo handling is required, more precise control is possible if the thrust of all the rotor systems can be simultaneously directed to all directions by an additional control system. This kind of control means is a goal of future studies.

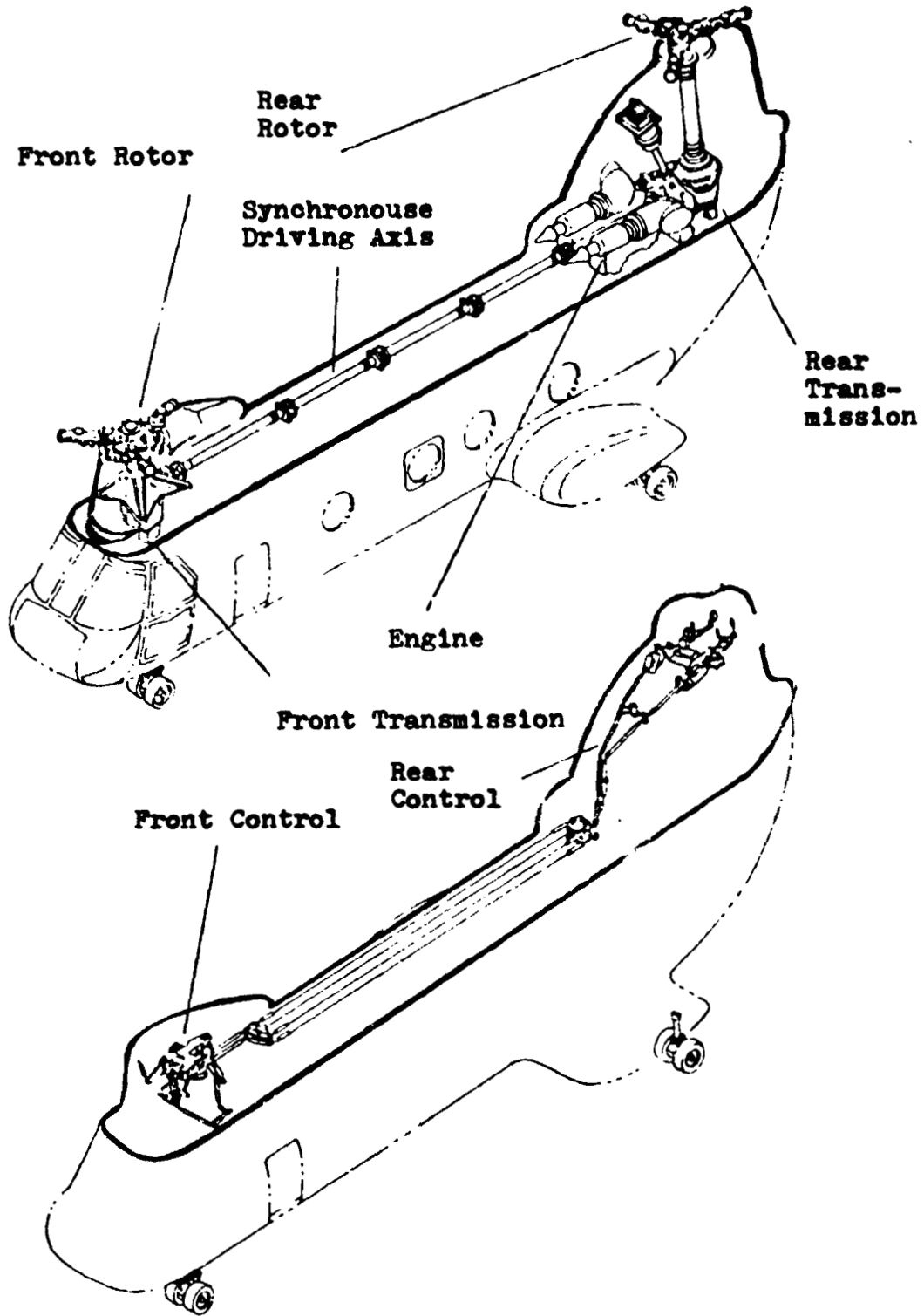

Fig. IV-15. Rotor System, Power Transmission System
and Rotor Control Means.

(c) Structure.

/158

The structure is almost the same as that of the passenger rota-ship which was previously described. The only difference is a cargo compartment which replaces the gondola for passengers. Methods for leading and unloading cargoes and the structure of the cargo compartment have been discussed.

The cargo compartment has a size of 30-m length, 10-m width and 2-m height, its volume being 600 m³. The cargo compartment has an open bottom and a cross section having a rectangular shape without a bottom. Five rails are attached on the ceiling and one rail is provided on each side wall. Cargoes are fixed by 15-units-per rail carriages with fitting means and five winches (attached only to the ceiling rails), as shown in Fig. IV-13. The cargo compartment has passage ways on both sides so that it is accessible from the cockpit for the supervision and the handling of the cargoes.

The variation of the gravity center caused by loading or unloading of cargoes is expected to create no problem since the rotor arms are sufficiently long in both longitudinal and traverse directions.

(d) Rotor System and Power Transmission System.

The rotor system, the transmission system and the engines are all of KV 107 IIA. (See Fig. IV-15.)

(1) Rotor System

The rotor system is of the tandem type, which is advantageous in that the rotor diameter can be lessened and the rotor system supporting frame can be shortened so that the weight is reduced. Each rotor is of the three-blade totally articulate type, and is rotated in the opposite direction in order to neutralize the anti-torque.

The main specifications of the rotor system are as follows:

Type:	Two-Rotor, Tandem Type
Diameter:	15.24 m
Blade Type:	NACA 0012
Blade Chord Length:	0.46 m
Number of Blades:	3 (per one rotor)
Rotation Speed:	264 rpm
Distance Between Centers of Rotors:	10.16 m
Direction of Rotation:	
Front Rotor:	Clockwise Viewed from Above Counter Clockwise Viewed from above

(2) Driving System.

The power is transmitted from two units of engines placed in the rear portion through the individual driving axes to intermediate reducing gears, thereby directly driving the rear transmission and simultaneously driving the front transmission through a synchronous driving axis. The front and rear transmission means reduce the rotation speed and transmit the power to the rotor shafts. Owing to an over-running clutch, even if one of the engines fail, the other engine can transmit its output independently.

(3) Engines.

For each rotor system, two units of free turbine type turbo shaft engines are used. The output rotation speed is selected by an engine control lever and maintained constant over the entire range of the engine load.

Name of Engine:	CT 58-IHI-140-1
Output (per unit):	1,500 HP (2.5 minutes) 1,250 HP (continuously)
Number of Rotation:	19,500 rpm

Fig IV-15 shows the construction of rotor system and the driving system.

/159

(e) On-Board Equipment.

This aircraft is provided with electronic devices for communication and navigation means, a computer for flight control and a cargo suspending winch system, as a set of main on-board equipment. The communication and navigation means are of the same type as those carried by civil airplanes in domestic lines. The computer is capable of reading and storing the data of the external environment conditions and the control data of the gas bags, and of controlling each rotor based on the data in the memories. The cargo suspending winch system can handle an arbitrary shape of cargoes and can suspend more than 30 tons along the height of 100 m.

(f) Mooring Means.

In many cases, when mooring conventional airships, their tips are moored to mooring masts. If airships are fixed in this way, reinforcement of leg structures or the like is indispensable, as well as mooring ropes. The present aircraft has a pivot type mooring means in a central position which is slightly ahead of the center of the wind pressure. This mooring means includes a winch (which can be designed so as to be used also as a cargo suspending

winch and render tension to the mooring rope together with the rotor lift during mooring operation, thereby ensuring the safety of the operation and reducing the necessary area for the mooring ground.

(g) Considerations on Engine Malfunctions.

As described in the section concerning flight control means, the present aircraft has four units of rotor systems which enable the aircraft's manipulation. The aircraft must be operated safely even when some of the engines fail. Each rotor system of this aircraft has two engines, and hence, eight units of engines are disposed around the aircraft body, as a whole. The rotor system, KV-107, is so designed that one of the two engines can ensure enough power for cruising when the other fails to function. The rotor systems have enough power capacity so that flight control ability may be maintained even when some of the engines fail to function. The design has been altered by increasing the initially selected rotor power in order to ensure safety.

IV-3-3. Problems of Mooring Sites, Sites for Landing and Take-Off, Etc.

In this section, ground facilities, training of on-board and ground crew members, etc., which are necessary for the operation of the rota-ship, will be discussed.

(a) Mooring Site and Mooring Means.

It is necessary to provide a hangar in order to avoid the dangers of high-place works in order to be able to take refuge in case of storms (typhoons), to perform major overhaul works, and for other reasons. Besides the hangar, it is also necessary to provide ground facilities by which the rota-ship is moored in an open space for the usual maintenance operations (including refilling of gas and fuel, inspection and replacement of on-board equipment, simple repair work on the hull and the structures, etc.).

In a conventional method for mooring an airship on the ground, the tip of the airship is tied to a fixed or moveable mooring mast, while the airship is fixed to a truck on the ground (sometimes riding on a rail) at a position in the rear of the center of the buoyancy. In this method, the airship can move 360 degrees and has the stability property of a "weathercock" against winds.

For this method, a mooring site must have at least the area of a circle with a radius equal to the airship body length.

/160

According to this method, the airship is controlled by a working rope which is suspended from the airship body and is pulled by a number of ground crew members, while the airship is descending. Thus, this conventional method has been associated with the danger that the airship might collide with the mooring mast or others, since the large body of the airship has poor maneuvering performance and is very sensitive to winds.

The above considerations suggest that one must note the following points when designing ground facilities for the rota-ship:

- (1) Reduction of the necessary area for ground facilities,
- (2) Reduction of the necessary members of ground crew,
- (3) The ability to moor the rota-ship under any weather condition, including the most severe temperature and winds (all-weather property),
- (4) Ground mooring land which can also be used as a take-off and landing ground (compatibility), and
- (5) The ability to take-off and land on the ground mooring facilities.

Ground facilities of the rota-ship have been discussed based on the above-mentioned requirements and the result is shown in Fig. IV-16.

In the proposed method for mooring, the rota-ship is connected with a ground mooring means at a position in the neighborhood of the center of the buoyancy. The necessary area for the mooring site has been reduced to 7800 m², namely, the area of a circle with a radius of about 50 m, which is about a half of the aircraft length. This area is about one fourth of that needed by the conventional mooring method for airships.

The mooring method using this mooring means is as follows: First, the mooring means usually contained in the ground is taken out while a guide rope is suspended from the rota-ship which is hovering above this mooring means. Then, a ground crew member engages this guide rope with another guide rope which is connected to the ground mooring means and the rota-ship descends with its buoyancy being controlled. The cargo handling system operator on the rota-ship operates the winch and winds up the guide rope. Finally, a circular fitting in the mooring means on the rota-ship is engaged with a concave fitting in the ground mooring means and both fittings are fixed by a nut, thus completing the connection of the rota-ship with the ground mooring means.

The ground mooring means has an escape which is about as long as a buggering stroke of the landing means, thereby absorbing the shock of the landing.

Owing to the ball joint connection, the aircraft can be moored securely even when the body is inclined slightly by winds in any direction. The rota-ship is also supported by a front and a rear landing means which enable the rota-ship to rotate around the ball joint and to face the wind direction, thereby ensuring a safe ground mooring with the stability property of a "weathercock."

Further studies must be done on this method for mooring. However, this method satisfies almost all the requirements mentioned previously. Namely, according to this method,

- (1) the necessary mooring land is 7800 m^2 , is about one fourth of that needed by the conventional method,
- (2) only two ground crew members are necessary, while five or more ground crew members are needed by the conventional method,
- (3) the mooring land can also be used as a take-off and landing ground and the rota-ship can take-off and land on the mooring means, and
- (4) the mooring means may be operated under all weather conditions if the mooring means on the ship and on the ground have reinforcement provisions.

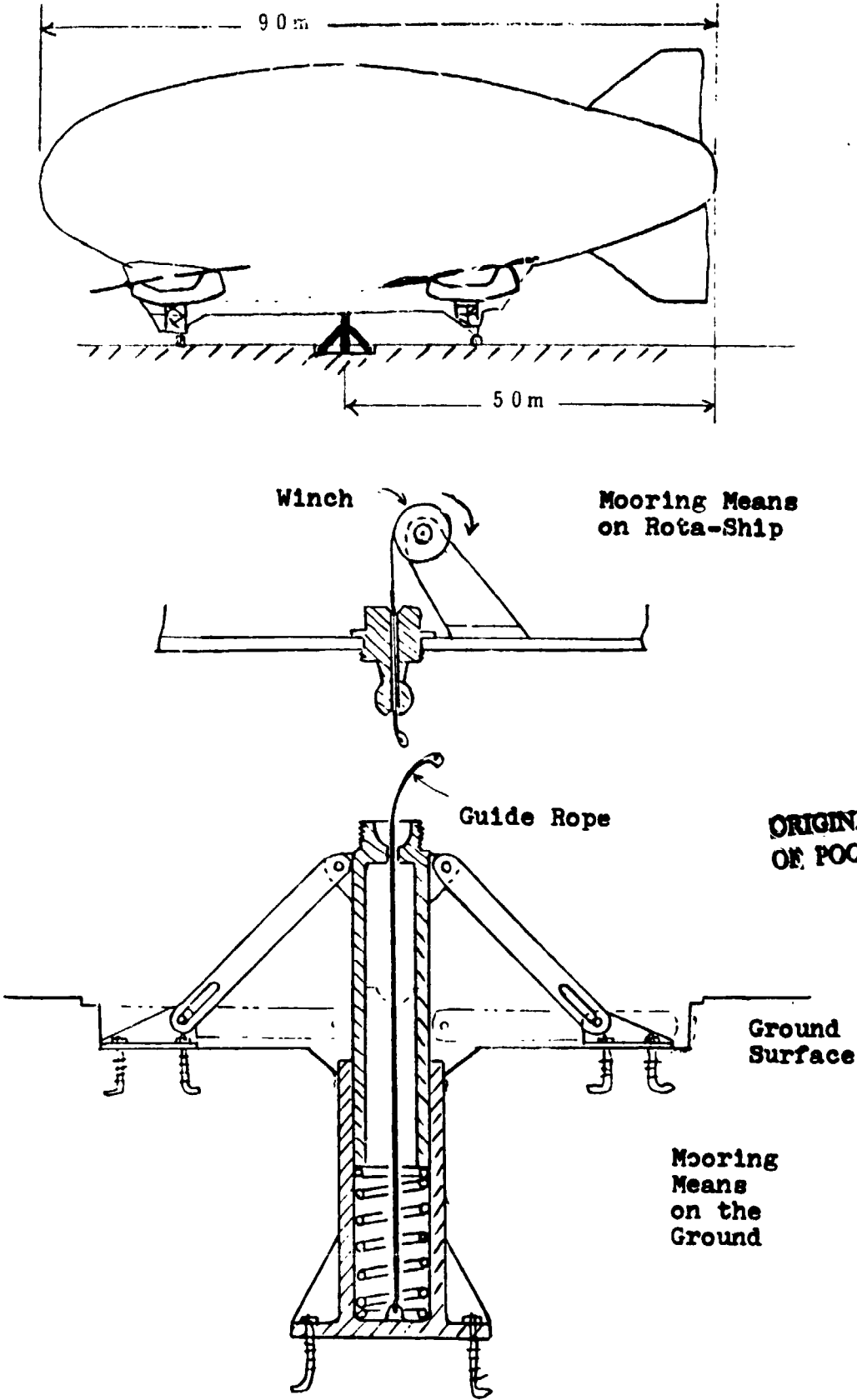

Fig. IV-16. Mooring Means for Cargo Rota-Ship.
(A patent application has been filed.)

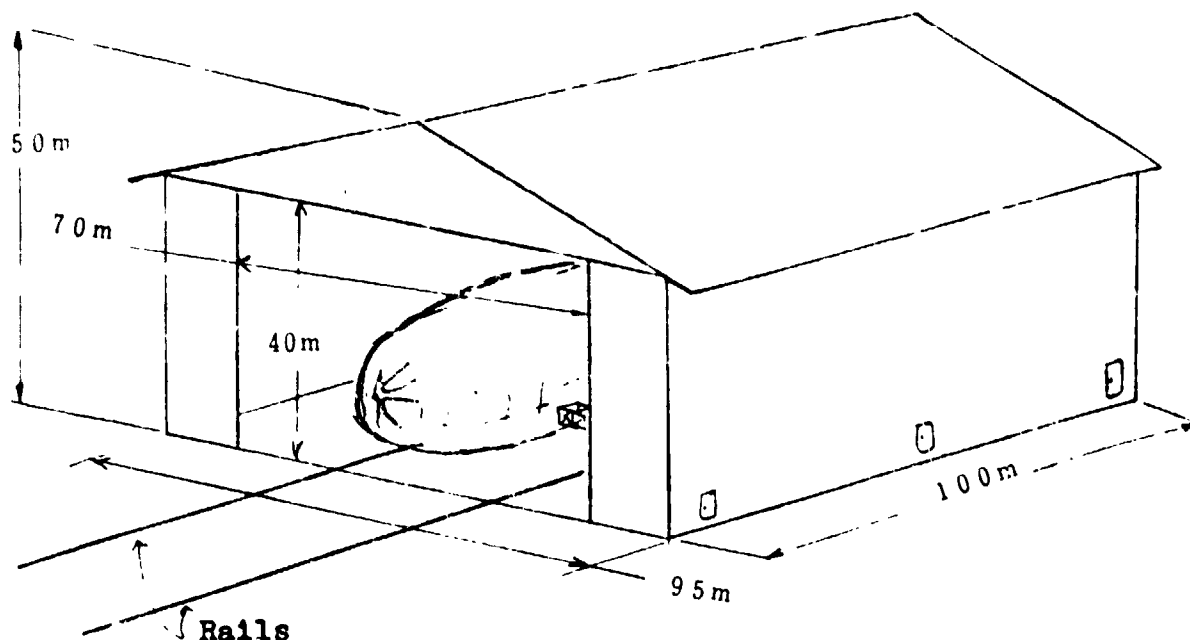

Fig. IV-17. Hangar for Cargo Rota Ship.

Fig. IV-17. Hangar for Rota-Ship for Cargo Transportation.

Building Area:	9,500 m ²
Building Size:	95 m (width) x 100 m (length) x 50 m (height)
Equipment:	Rails, high-place work carts, working stands, tools for replacing rotor systems, tractors, winches (four 30-ton units), sealing means for gas tank systems, maintenance tools, office and communication devices.

The hangar accommodating the rota-ships for emergency or overhaul is required to have the size and the equipment shown above.

This kind of hangar is also necessary as a final assembling factory for the rota-ship.

(b) Take-Off and Landing Ground.

The rota-ship has hovering ability as well as vertical take-off and landing ability. Therefore, it can land on ground mooring means in a base or can take off directly from the mooring means. In addition, the rota-ship can land on a take-off and landing ground, as helicopters or STOL planes, and then may be moored in the mooring site after travelling by means of a tractor. It may also be moved from the mooring site to the take off and landing ground by the tractor after being disengaged with the mooring means.

In the following, a rota-ship base in which the ship takes off from and lands on a ground mooring means without using a hangar is tentatively called a "ground mooring base." A base equipped with a take-off and landing ground, a mooring site and a hangar is called a "rota-ship base." Figs IV-18 and IV-19 show designs of a "ground mooring base" satisfying the specification of the B-class ground heliport and of a "rota-ship base" satisfying the specification of the A-class ground heliport, according to a method which is almost the same as the method for determining the size of a ground heliport for KV 107 IIA.

Fig. IV-18. D-Class Ground Rota-Ship Base.

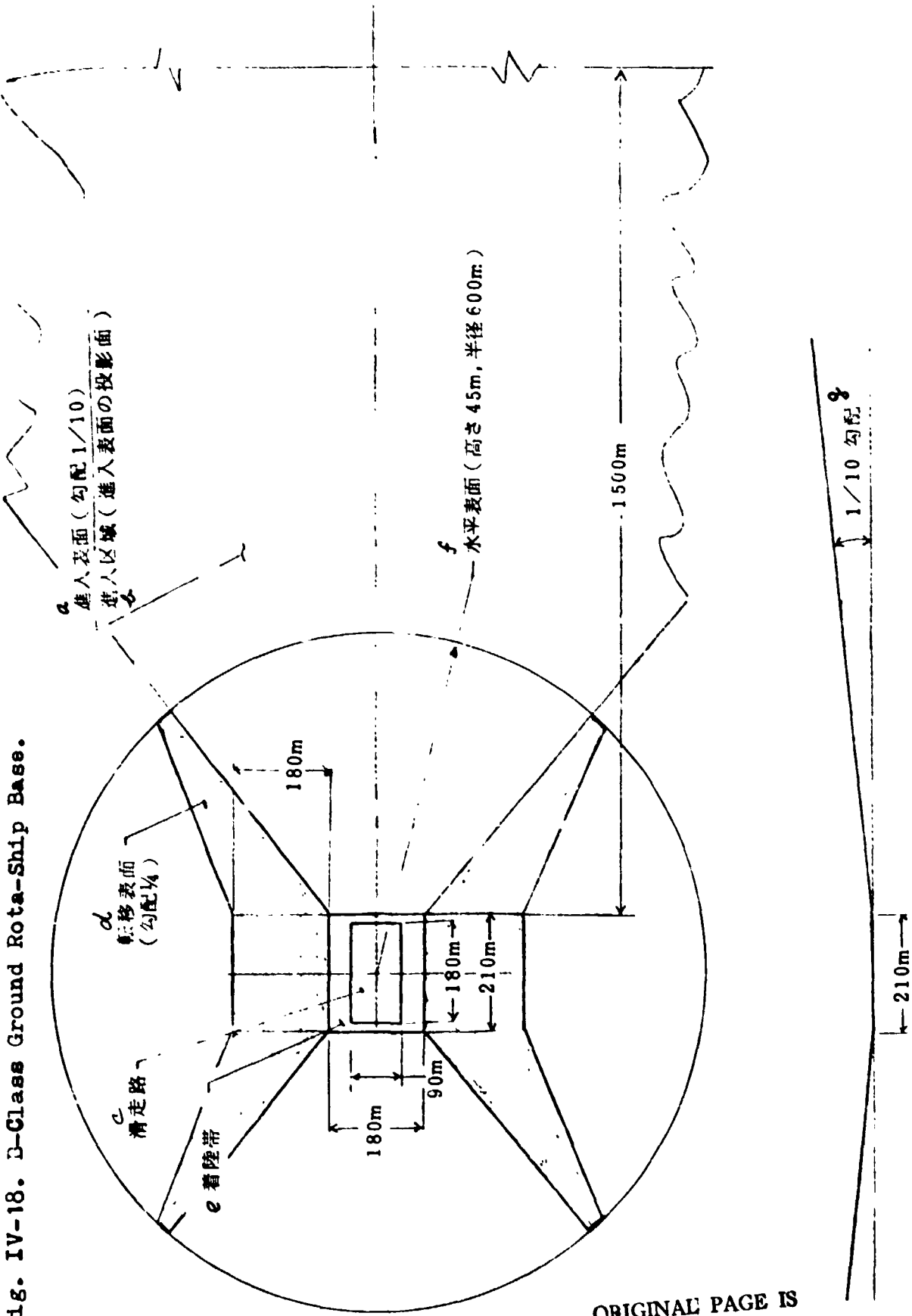

ORIGINAL PAGE IS OF POOR QUALITY

Key to Fig. IV-18.

- a: Admission Surface (slope: 1/10)
- b: Admission Zone (Projection of the admission surface)
- c: Runway
- d: Transition Surface (Slope: 1/4)
- e: Landing Zone
- f: Horizontal Surface (height: 45 m, radius: 600 m)
- g: 1/10 slope

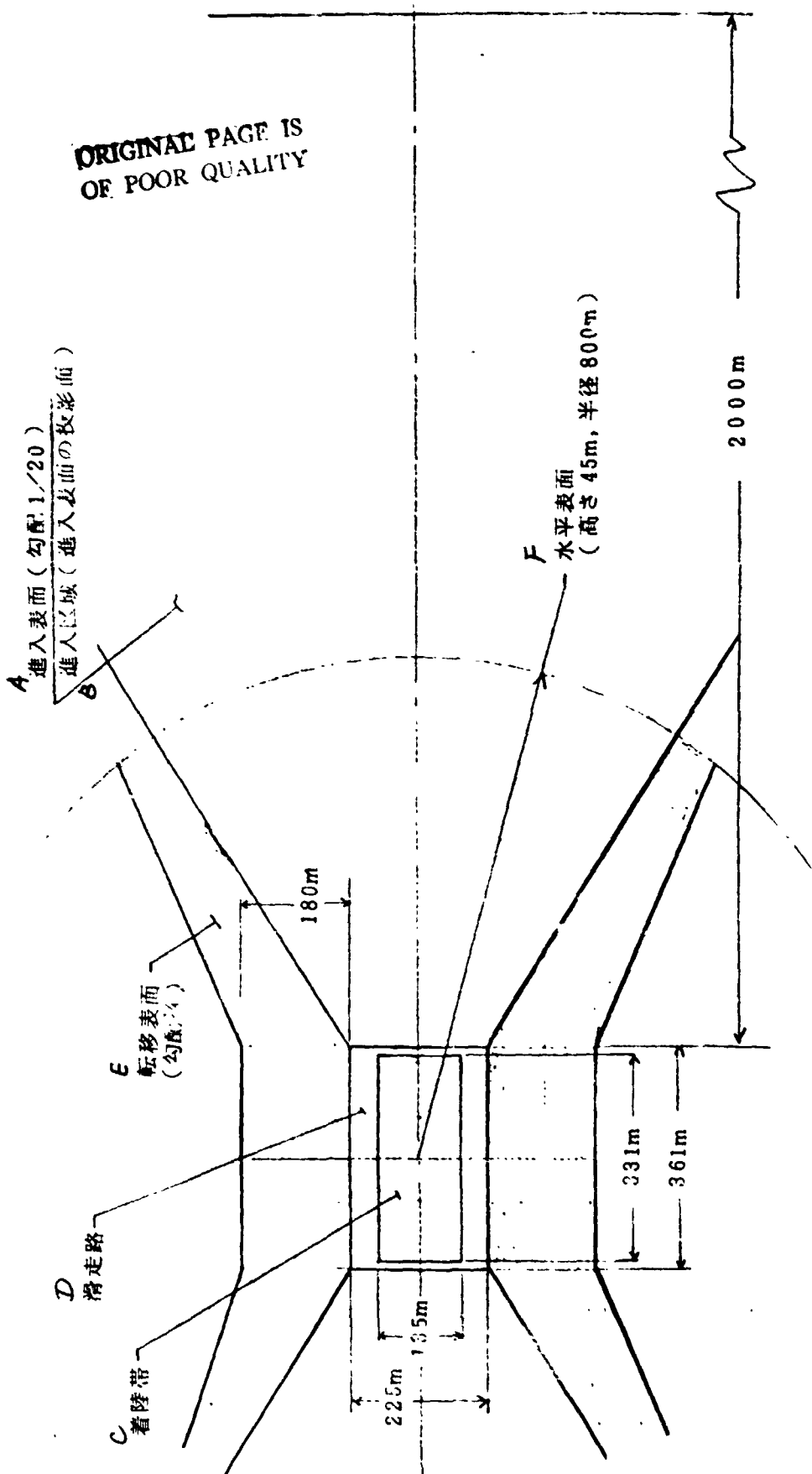

FIG. IV-19. A-Class Ground Rota-Ship Base for Cargo Transport.

Key to Fig. IV-19.

- A: Admission Surface (slope: 1/20)
- B: Admission Zone (Projection of the admission surface)
- C: Landing Zone
- D: Runway
- E: Transition Surface
- F: Horizontal Surface (height: 45 m, radius: 800 m)

B-Class Ground Rota-Ship Base for Cargo Transportation
(Ground Mooring Base):

/165

Runway Length:	90 m x 2 = 180 m Twice as long as the total length of the rota-ship.
Runway Width:	60 m x 1.5 = 90 m 1.5 times as long as the total width
Landing Zone Width:	180 m + 15 m x 2 = 210 m
Landing Zone Length:	2 x 90 m = 180 m Based on the minimum ratio 2 (landing zone width/runway width) required by Aviation Law.
Landing Zone Area:	210 m x 180 m = 37,800 m ²
Landing Zone Strength:	The landing zone must endure the impact of 14.1 kg/cm ² .

Cargo strages, maintenance vehicle garages and offices in a ground mooring base must be located in the neighborhood of the landing zone but the buildings should not interfere with the admission surface or the transition surface.

A-Class Ground Rota-Ship Base for Cargo Transportation:

Runway Length:	1.84 x 180 m = 331 m Calculation based on the landing distance, 50 feet, which KV-107 needs when one of the engines fails. Cf. $1.84 = \frac{92}{50} = \frac{\text{A-Class Runway Length}}{\text{B-Class Runway Length}}$
Runway Width:	1.5 x 90 m = 135 m 1.5 times as long as that of the B-class runway.
Landing Zone Length:	331 m + 2 x 15 m = 361 m
Landing Zone Width:	(50 m/40 m) x 180 m (B-Class Landing Zone Width) = 225 m

Landing Zone Area. 361 m x 225 m = 81,225 m²

Landing Zone
Strength: The landing zone must endure the impact of 14.1 kg/cm².

A rotor ship hangar (See Fig. IV-17.), cargo strages in a rota-ship base, etc. must be located in the neighborhood of the landing zone, but they should not interfere with the admission surface or the transition surface.

Fig. IV-20 shows an example of layout of a rota-ship base for cargo transportation. As seen from the figure, a wide area is necessary for a rota-ship base. However, if the rota-ships take refuge in rota-ship bases just as large-size civil airplanes do when a typhoon approaches, it is possible to operate 15 rota-ships with 3 rota-ship bases. It is also possible to operate 10 rota-ships with one rota-ship base (176 thousand m²) and five ground mooring bases (area: 44,000 m², $\frac{1}{4}$ of the area of a rota-ship base).

(c) Training of On-Board and Ground Crew Members.

There are four on-board crew members of the rota-ship (for cargo transportation): two pilots, one on-board mechanic and one cargo handling system operator. The pilot, must at least have a license which allows him to operate a KV-107 helicopter and a conventional type of airship. In addition, it will be indispensable for pilots to receive special training for operating the cargo transportation rota-ships.

The following numbers of ground crew members are necessary per one ground mooring base:

- 1) three flight navigators to analyze meteorological conditions at various places: one chief member, one planner and one office worker, and
- 2) twelve members -- five maintenance engineers for the four-unit rotor systems and seven for the ship structures -- who must have sufficient training in ship take-off and landing, mooring ships on the ground, and loading and unloading the cargoes, for these operations to be safely and efficiently performed.

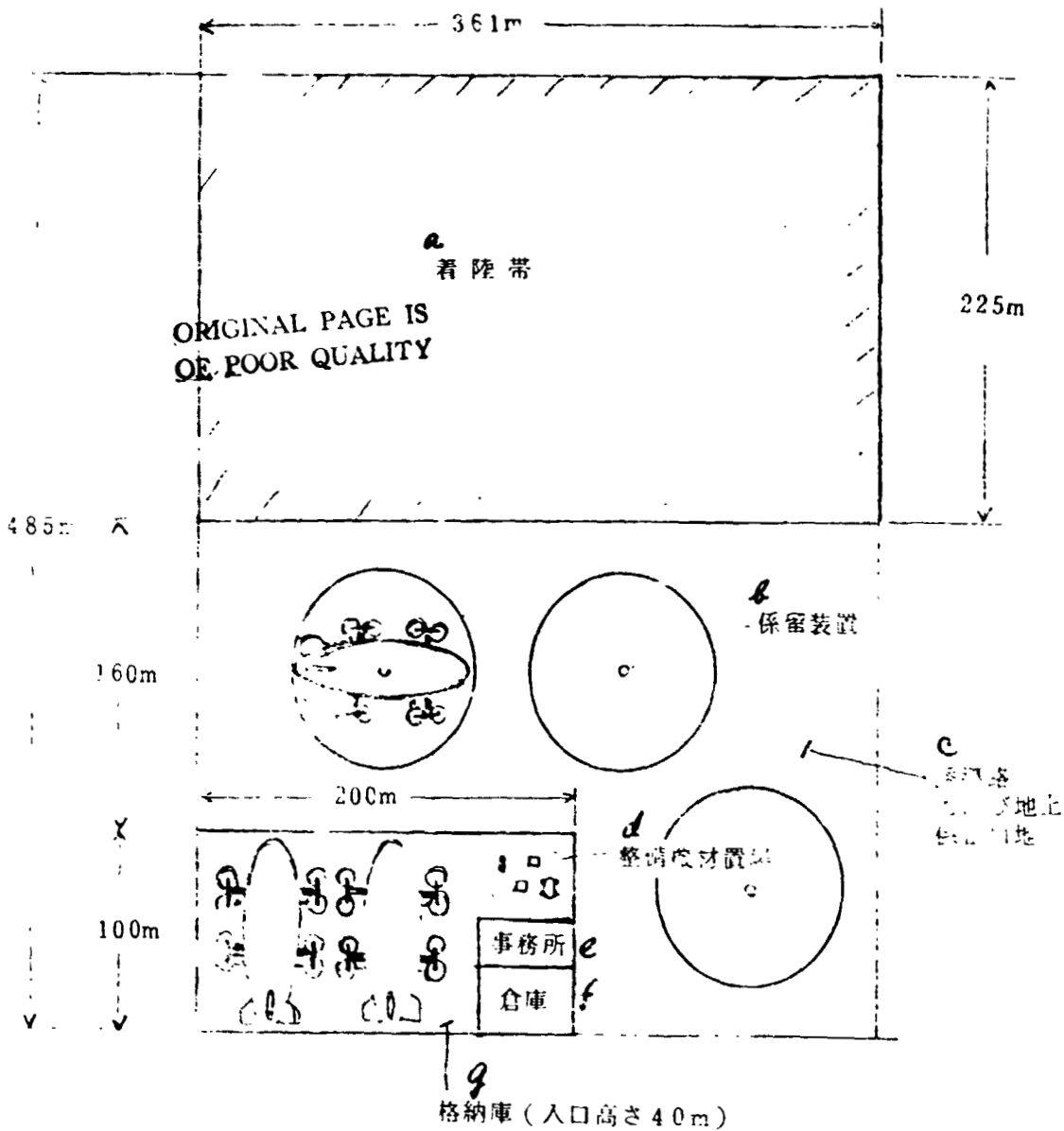

Fig. IV-20. A Layout of Rota-Ship Base for Cargo Transport.

Key to Fig. IV-20.

- | | |
|---------------------------------------|----------------------------------|
| a: Landing Zone | b: Mooring Means |
| c: Guide Ways and Ground Mooring Land | d: Maintenance Equipment Storage |
| e: Office | f: Storage |
| g: Hangar (Entrance Height: 40 m) | |

Total Area: about 177,000 m³ (53,640 Tsubo)

Landing Zone Area: about 81,300 m³ (24,640 Tsubo)

Building Area:	20,000 m ³ (6,060 Tsubo)
Number of Aircraft that the Hangar can Accommodate:	2
Number of Aircraft that can be Moored Outdoors:	3

IV-3-4. Development Plans and Development Expenses.

/167

The rota-ship, which is a combination of airship techniques and conventional aircraft techniques, including helicopter technology, is the most realizable among various plans of hybrid LTA's, and hence it is promising as a future heavy cargo transportation system for carrying heavier or more voluminous cargoes beyond the limitation of conventional helicopters.

It is not easy, however, to establish a development plan and to estimate the corresponding development expenses based on conventional aeronautic techniques, due to the lack of experience in this field. Despite this difficulty, the following estimate was made:

(a) Development Plan.

The techniques to be developed include techniques concerning airships, namely, aerodynamic characteristics of airship body shapes, material characteristics and load/strength analyses of non-rigid hull structures, suspension means and structures, means for controlling the center of helium gas buoyancy, manufacturing and maintenance of non-rigid airship bodies, etc. These techniques may be realized within the conventional range of aircraft techniques in Japan. Specifically, they will be developed through wind-tunnel tests, partial structure tests, manufacturing of and tests on reduced scale models, material characteristics cylinder tests, etc.

After individual techniques have been completely developed, they will be integrated and will be followed by demonstrations of flight properties, i.e., dynamic stability characteristics of the rota-ship, hovering characteristics, maneuvering performances, etc., by experiments using reduced-scale models.

The following two proposals for the development plan for the rota-ship were made:

First Plan: A three-year development plan using a reduced-scale model with a hull volume of about 100 m³.

Second Plan: A four-year development plan, using a reduced-scale model with a hull volume of about 5,000 m³ and with two small-size helicopters which will be borrowed during the test period.

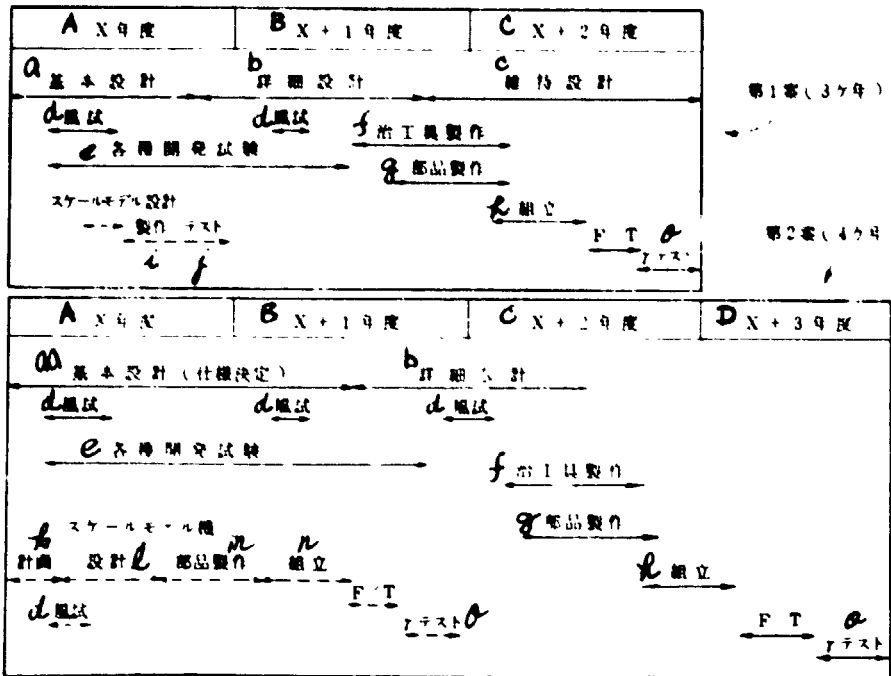

Fig. IV-21. Rota-Ship Development Plans.

Key to Fig. IV-21.

- A: Fiscal Year X
- B: Fiscal Year X + 1
- C: Fiscal Year X + 2
- D: Fiscal Year X + 3
- a: Basic Designs
- b: Detail Designs
- c: Maintenance Designs
- d: Wind Tunnel Tests
- e: Development and Tests of Various Kinds and Techniques
- f: Manufacturing of Jigs and Tools
- g: Manufacturing of Parts
- h: Assembling
- i: Manufacturing of Reduced-Scale Model
- j: Tests of Reduced-Scale Model
- k: Plan of Reduced-Scale Model
- l: Design of Reduced-Scale Model
- m: Part Manufacturing of Reduced-Scale Model
- n: Assembling of Reduced-Scale Model
- o: Tests

(b) Development Expenses.

/168

Estimate of development costs of one passenger rota-ship and one heavy cargo rota-ship based on the three-year plan (the first alternative) are shown in the following, where ground mooring equipment and assembling hangar are excluded and all the monetary values are calculated by the 1978-1980 price base:

Estimate of Development Cost of the Rota-Ship

(Three-Year Plan)

	Per one Passenger Rota-Ship	Per one Heavy Cargo Rota-Ship
Development and Test Costs for New Techniques	660 million yen	660 million yen
Direct Material Costs	670	2040
Processing and Jig/Tool Costs	600	780
Other Expenses, Profit, Etc.	330	600
TOTAL	2,260 million yen	4,080 million yen

The estimated development costs are about 2,260 million yen and 4,080 million yen per one passenger rota-ship and per one heavy cargo rota-ship, respectively. The fractions of the prices of helicopter rotor systems in the direct material costs are about 60% and 80%, respectively.

When ten aircraft of each type are manufactured, the average unit prices of the passenger rota-ship and the heavy cargo rota-ship are about 1,500 million yen and 3,300 million yen, respectively. In this calculation, the fixed costs, including the technical development and test costs and the costs of jigs and tools, are divided among ten aircraft of each type.

The second alternative of the four-year plan will require an additional expense of about 500 million yen besides the development expenses required by the first alternative.

Discussions regarding the design and the manufacturing of the rota-ship have been presented above. However, many aspects concerned with the operation of the rota-ship will also have to be developed. These aspects are objects of further studies, together with others such as the rota-ship design requirements related to its operation.

IV-3-5. Estimates of Operating Costs of Rota-Ships for Passenger Use.

Since the rota-ship has never been operated, it is extremely difficult to estimate its operating cost. However, in this section, the operating costs will be estimated based on the information provided by the operation of YS-11 airplanes in the domestic airlines of Japan.

(a) Assumptions for Estimation.

For operating costs, the following assumptions are made:

(1) Main Specifications.

The main specifications of operating conditions are shown in Table IV-6 in comparison with those of the YS-11.

(2) Line Distance.

300 km

(3) Line Flight Time and Annual Total Flight Time.

Take-Off:	5 minutes
Ascent:	10 minutes
Horizontal Cruising	2 hours (including the cruising margin)
Descent:	5 minutes
Landing/Mooring	10 minutes
Total Line Flight Time:	2 hours and 30 minutes

/169

The annual total flight time is about 1,700 hours, which is about 70% of the average annual total flight time of the YS-11 operation in Japan. This estimate was made considering the fact that the rota-ship is sensitive to bad weather conditions and requires more time to be handled on the ground.

(4) Other costs.

The operating costs, measured by 1977 fiscal year yen value, will be calculated. The YS-11 operation in Japan is supported by an extremely-high-standard operation assistance organization which is primarily designed for the jet plane operation. As short-distance transportation, it might be said that the YS-11 operation is too costly, particularly in terms of management expenses. Therefore, in the calculation, particular attention has been paid to this fact. This will be seen in the following description.

The fuel cost is calculated as:

47,000 yen/1 kl (including 13,000 yen of aircraft fuel tax).

Table IV-6. Comparison of Basic Specifications.

	Rota-Ship	YS-11
Gross Tonnage (ton)	32	24.5
Payload (ton)	10.3	6.5
Number of Seats	120	60
Cruising Speed (km/hour)	150	475
Flight Distance (km)	600	2,330
Engines	600 HP x 2 x 4	3,040 HP x 2
Total Length (m)	80	26.3
Total Width (m)	52	32
Total Height (m)	30.5	9
Crew Members	two pilots and one mechanic	two pilots
Price (million yen)	1,500	650* 130*

*In case a new plane is built.

**The accounting price for calculating the operating cost

(b) Direct Operating Cost.

(1) Cost of Crew Members.

The crew member cost of the US-11 operation in Japan is 74,000 yen per hour for a 300-km line. This cost is approximately twice that of similar local airlines in the U.S.A. and includes the crew member training cost which is primarily required for jet plane operation. The corresponding cost for the rota-ship is estimated to be equal to 0.6 times as much as that of the YS-11 operation. The cost corresponding to the mechanic required for the rota-ship operation is calculated at 0.8 of that of the pilots.

Thus, the cost of the pilots of the rota-ship is:
 $74,000 \times (\frac{1}{2}) \times 0.6 = 22,000$ yen per one pilot, 44,400 yen per two pilots, and the cost of the mechanic of the rota-ship is: $22,200 \times 0.8 = 17,760$ yen per one mechanic. The total cost for the crew members is: 62,160 yen, i.e., about 62,000 yen per hour.

/170

(2) Fuel Cost.

Since the fuel consumption rate per hour is 620 kg (0.77 kl), the fuel cost is,

$$0.77 \times 47,000 = 36,000 \text{ yen/hour.}$$

(3) Maintenance Cost.

The spare part cost is calculated to be 3% of the aircraft price and is,

$$1,500 \text{ million yen} \times 0.03 / 1,700 = 26,000 \text{ yen per hour}$$

The labor cost of the maintenance work is calculated to be the same as that of the YS-11 operation and is,

$$35,000 \text{ yen/hour}$$

The cost for managing the maintenance work is calculated to be 0.6 of that of the YS-11 operation and is,

$$28,000 \text{ yen/hour}$$

Summing up the above costs, the maintenance cost per one flight hour is,

$$89,000 \text{ yen/hour.}$$

(4) Insurance.

The average insurance rate of the rota-ship is calculated to be 1%, twice as much as that of airplanes in domestic airlines in Japan, 0.5%. Thus, the insurance cost is,

$$1,500 \text{ million yen} \times 0.01 / 1,700 = 9,000 \text{ yen/hour.}$$

(5) Depreciation Cost of Aircraft.

Considering the ten-year constant depreciation and the 10% final price, the depreciation cost is,

$$1,500 \text{ million yen} \times 0.9 / 10 / 1,700 = 79,000 \text{ yen/hour.}$$

Summing up the above costs, the direct operating cost is,

$$275,000 \text{ yen/one hour of flight.}$$

If the ratio-ship is operated in a 300-km line (flight time: 2.5 hours), the direct operating cost is,

$$275,000 \times 2.5 = 687,500 \text{ yen.}$$

The direct operating cost per seat per km is 19.1 yen and about 45% higher than that of the YS-11 operation, 13.2 yen.

(c) Total Operating Cost.

In the YS-11 operation in Japan, the indirect operating cost is 80% of the direct operating cost, on the average. When the rota-ship is used, in particular in a short-distance airline, it will be essential to try to reduce this indirect operating cost; such reduction will be possible through prudent management. Thus, the indirect operating cost is calculated to be 50% (80% x 0.6) of the direct operating cost.

Consequently, the total operating cost is,

$$687,500 \times 1.5 = 1,031,000 \text{ yen.}$$

/171

The total operating cost per seat per km is 28.6 yen and about 21% higher than that of the YS-11 operation, 23.6 yen. Fig. IV-22 shows various kinds of operating costs, compared with those of the YS-11 operation.

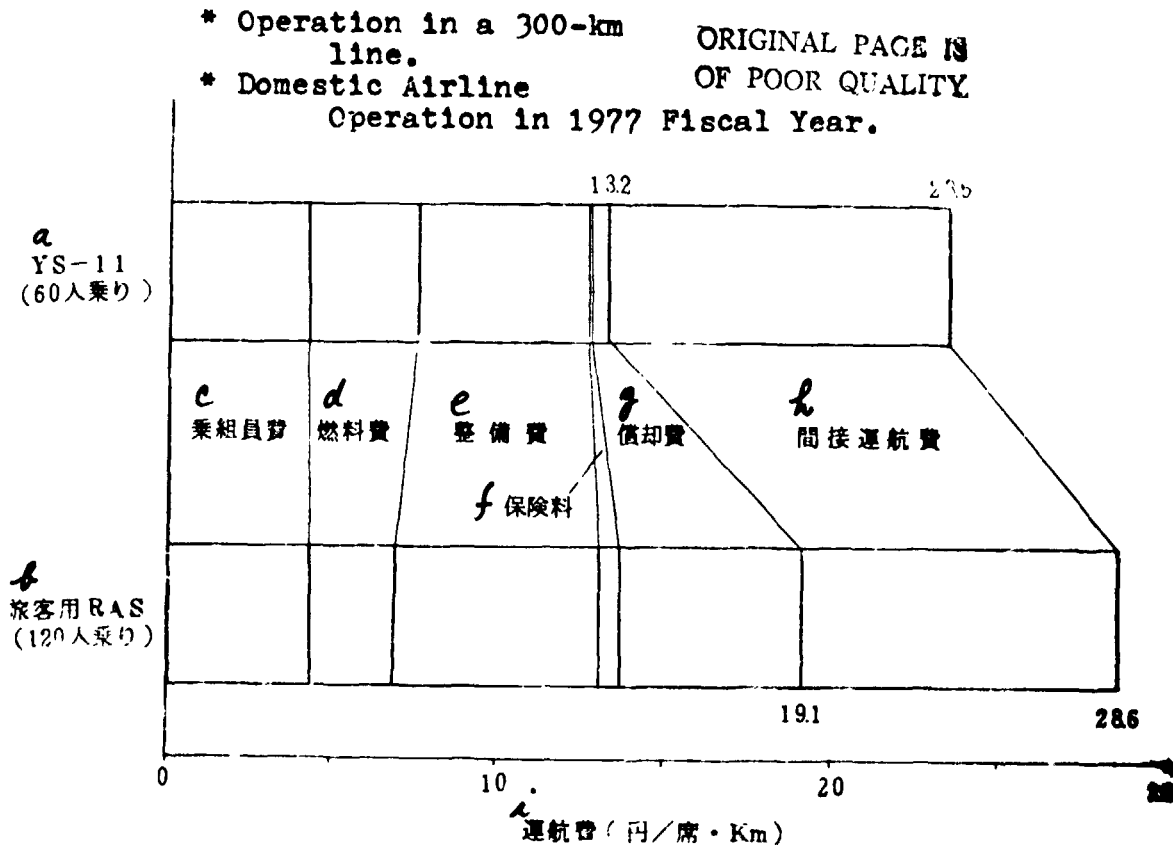

Fig. IV-22. Comparison of Operating Costs of Passenger Rota-Ship and YS-11.

Key to Fig. IV-22.

- a: YS-11 (60 passengers)
b: Rota-ship for Passenger Transportation (120 passengers)
c: Crew Member Cost
d: Fuel Cost
e: Maintenance Cost
f: Insurance
g: Depreciation Cost
h: Indirect Operating Cost
i: Operating Cost (yen per seat km)

IV-3-6. Estimates of Operating Costs of Rota-ship for Heavy Cargo Transport.

The estimates of operating costs of a rota-ship for heavy cargo transportation are shown in Table IV-7. These estimates were calculated by the Asahi Helicopter Company, Ltd. based on the current standard for calculating the air fare of the helicopters. More specifically, these calculations are based on the standard applied to "Irregular Air Transportation Operation."

The main assumptions on which the estimates are based are,

- (1) 30 tons of payload,
- (2) 3.3 billion yen aircraft cost, and
- (3) 400 working hours per year.

According to the currently applied standard, the costs are as follows:

(A) Variable Costs.	
(i) Labor Cost for Flight:	4,000 yen per person per hour
(ii) Fuel Cost:	340,000 yen per hour
(iii) Maintenance Cost:	800,000 yen per hour
(B) Fixed Cost.	
(i) Personnel Cost:	160,000 yen per hour
(ii) Depreciation Cost:	990,000 yen per hour
(iii) Aviation Insurance:	990,000 yen per hour
(iv) Fixed Asset Tax:	70,000 yen per hour
<u>Sub-Total:</u>	<u>3,350,000 yen/hour</u>
(C) Miscellaneous Operating Cost:	
8.5% of the above subtotal:	285,000 yen/hour
(D) General Management Cost:	
10% of the above subtotal:	340,000 yen/hour
(E) Profit:	
5% of the sum up to (D):	190,000 yen/hour
(F) Interest Payment:	
50% of (D):	170,000 yen/hour
<u>Grand Total:</u>	<u>4,240,000 yen/hour</u>

/172

Some of the above data are explained below:

Paid Work Hours: In Japan, due to the very strict Aviation Regulation Rule, it is difficult to keep even 300 hours per year of paid work hours. (Cf. 1,000 hours/year is not rare in the U.S.) However, even in Japan, 700 hours per year was once recorded. Considering the fact that the rota-ship will be used exclusively in construction sites of power plants, annual work hours have been set at 400 hours.

Fuel Unit Cost: This is determined to be 107,000 yen per kl. The average fuel cost for helicopter uses is 7,200 yen/kl. A tax of 1,300 yen/kl is added to this. In addition, since the fuel is usually transported in drum cans on the ground to the area where the helicopters are used, the fuel unit cost becomes 30% higher. Thus, the final unit cost is 107,000 yen/kl.

Maintenance cost: The maintenance cost of KV-107 was used, i e., 800,000 yen per hour.

Aviation Insurance: This is estimated at twice as much as the labor cost of helicopters of the largest size, assuming that the necessary number of personnel for operation is about 15:

160,000 yen per hour.

Miscellaneous Operating Cost: 8.5 %, the same as that of large-size helicopter operation.

Note: The above estimates were made by Mr. Michiaki Kunihiro, director, department of development, Asahi Helicopter Co., Ltd.

Translator's Note: Page 173 of the original text is missing. Page 185 of the original text appears where page 173 should be. Table IV-7 and Table IV-8 are also missing. Perhaps they should have appeared on page 173.

/173

IV- 4-1. Outline.

Requirements for efficient means of transportation and handling of large-size heavy cargoes have been outstandingly growing. Probably, they will keep growing in the future, too. The conventional means of transportation, however, cannot satisfy such requirements for the following reasons:

- (1) Since the conventional means of heavy cargo transportation are very expensive, they are sometimes not available at the time when they are urgently needed.
- (2) They are not capable of carrying cargoes which are heavier than certain limits.
- (3) They are subject to several external restrictions.

As a possible novel transportation means which can satisfy such unfulfilled requirements, the Skycrane has been selected for the survey study. The possibilities of its uses will be discussed in this section. A Skycrane consists of a ball-shaped gas cell containing helium gas, wings attached to the exterior of the gas cell and a cockpit which is connected to the bottom of the gas cell through a swivel joint. (See Fig. IV-23.)

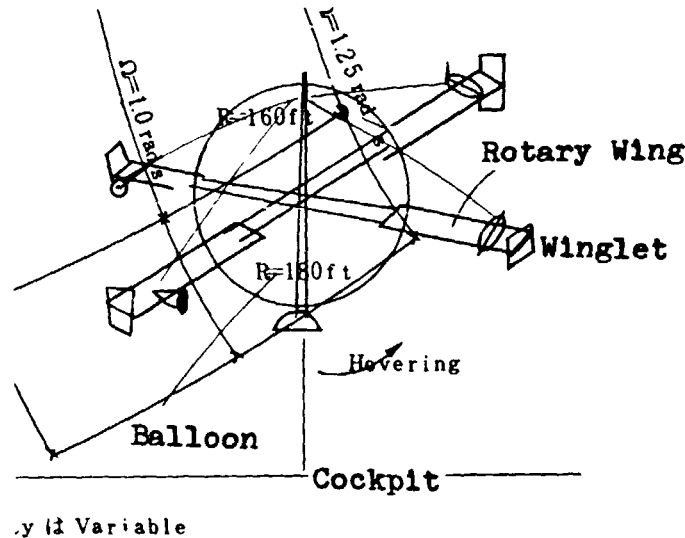

Fig. IV-23.

Translator's Note: Pages 174 and 185 have been printed on the same page (overlapping) in the original text. Fortunately, page 174 is readable. It should be noted, however, that Fig. IV-23 of page 174 overlaps Fig. IV-33 of Page 186.

ORIGINAL PAGE IS
OF POOR QUALITY

Each wing has a propelling means provided in a position near its tip. The wings rotate along the central axis of the ship body with the thrust of the propelling means. Thus, the wings which rotate (referred as "rotary wings," hereinbelow) generate dynamic lift. In the Skycrane, the ship weight is supported by this dynamic lift created by the rotary wings as well as the static buoyancy of the balloon. The support of the ship body is, in general, distributed, as:

Static Buoyancy of the Balloon = 40% of
(Dead Weight + Fuel Weight + Payload), and
Dynamic Lift of the Rotary Wings = 60% of the Payload.

The rotary wings are used to control the ship body as well as provide the partial lift. In usual LTA's, when loading and unloading cargoes, the buoyancy or the lift must be controlled by adjusting the gas volume or ballasts. The Skycrane is able to control the lift promptly by means of the pitch control of the rotary wings. The ascent, the descent and the hovering are performed by controlling these rotary wings, while a horizontal propelling force is provided by winglets on the tips of the rotary wings for the forward flight. The winglets are adjusted by cyclic pitch control.

The Skycrane suspends a heavy cargo by a wire while hovering, travels to the destination with the suspended cargo after ascending, and then hovers again while unloading the cargo. Therefore, the stability and the maneuvering performance as excellent as those of helicopters are required to the Skycrane. This requirement is satisfied by providing the Skycrane with the rotary wings which have a large rotary surface.

The maneuvering of the ship body is performed by the cyclic pitch and the corrective pitch angle control. Cargoes are suspended by a wire which is suspended from the bottom of the cockpit. The wire is wound by a winch provided in the cockpit.

/175

Conceptualizing designs of a 40-ton payload and a 70-ton payload Skycranes are shown in Table IV-9 and Fig. IV-24, followed by a detail discussion. The speed in those designs is 50 + 18.5 km/h and the flight distance is 150 km. As a result, it was concluded that the Skycrane is sufficiently satisfactory as a new means of heavy cargo transportation.

Table IV-9. Specifications of Mitsubishi Skycrane.

Specifications	Unit	40-Ton Payload Type	70-Ton Payload Type
Gross Weight	kg	74,742	123,482
Dead Weight	kg	31,240	48,050
Useful Load (Fuel Weight)	kg	43,559 (4,283)	73,476 (6,989)
Maximum Cruising Speed	km/h	50 + 18.5	50 + 18.5
Flight Distance	km	(*) 150 plus 30 min. of Hovering	(*) 150 plus 30 min. of Hovering
Balloon Radius	m	24.68	29.07
Wings	Radius	5.72	48.76
	Rotation	rad/s	1.0
	Wing Tip Speed	m/s	45.72
	Solidity	-	0.1
Pro- pell- ers	Diameter	m	6.1
	Rotation	rps	10.66
	Number of Propellers	-	4
	Average Efficiency	-	0.77
$V_q^{(**)}$	m^3	61,090	99,900
Winglet Area	m^2	35.72	27.87
Max. Take-Off Power	HP	1,800 x 4	2,800 x 4
Price (***)	yen	3.1 billion	4.6 billion

Notes: (*) Winds of 10 knots are considered.

(**) At the altitude of 1,000 m and the temperature of STD + 20° C.

(***) The unit price when ten aircraft are manufactured.

ORIGINAL PAGE IS
OF POOR QUALITY

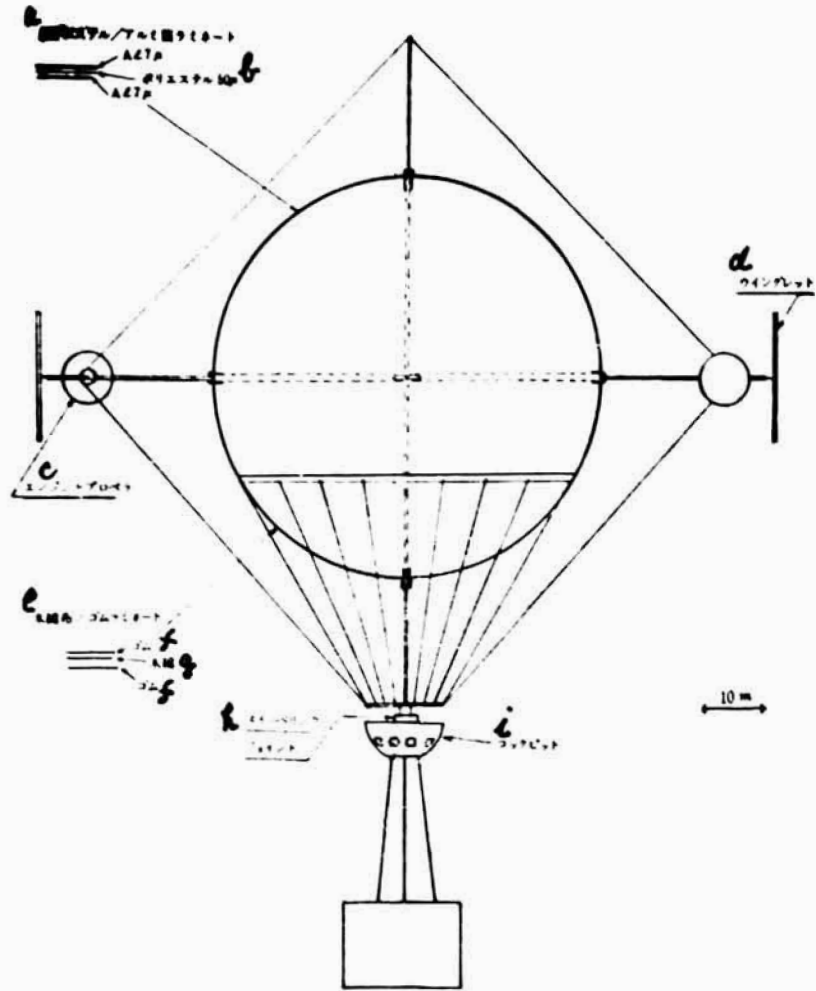
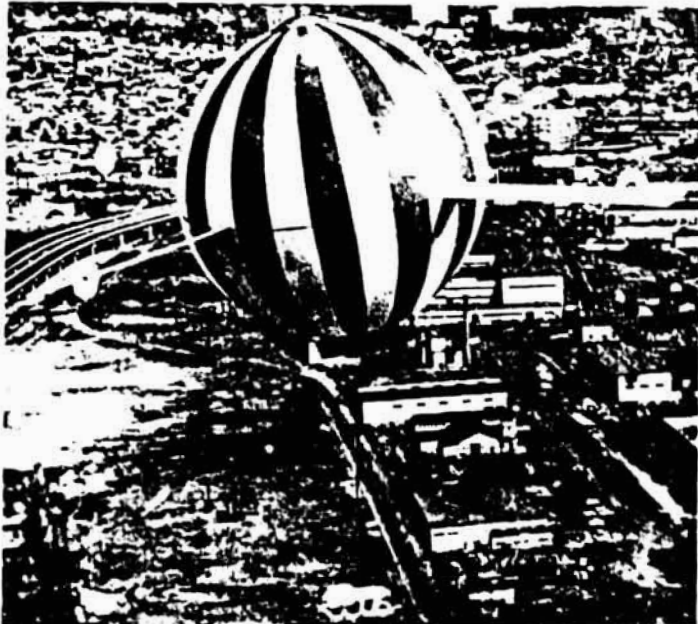

Fig. IV-24 Mitsubishi Skycrane
(40-Ton Payload Type)



Key to Fig. IV-24.

- a: Polyester/Aluminum Film Lamination
- b: Polyester
- c: Engines and Propeller
- d: Winglet
- e: Cotton Cloth/Rubber Lamination
- f: Rubber
- g: Cotton Cloth
- h: Swivel Joint
- i: Cockpit
- j: Synthesized Photograph of Aerocrane (for reference)
By the courtesy of All American Engineering Company.

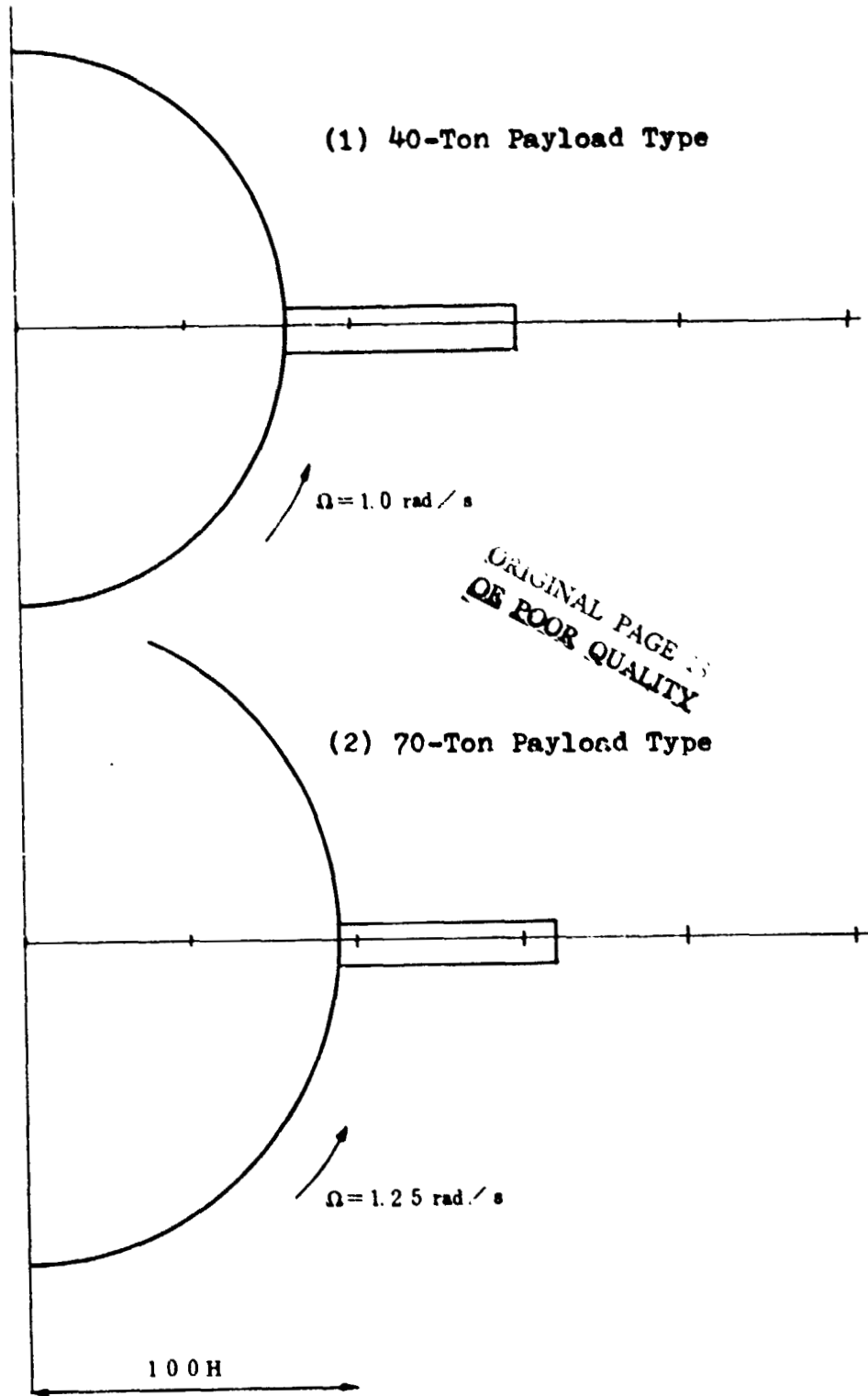

Fig. IV-25. Ship Body Size.

IV-4-2. Determining Skycrane Specifications.

Translator's Note: Pages 178 and 182 of the original text have been printed on the same page (overlapping). Page 178 is not readable. Fig. IV-26 on Page 128 overlaps Tables IV-11 and IV-12 on Page 182 of the original text.

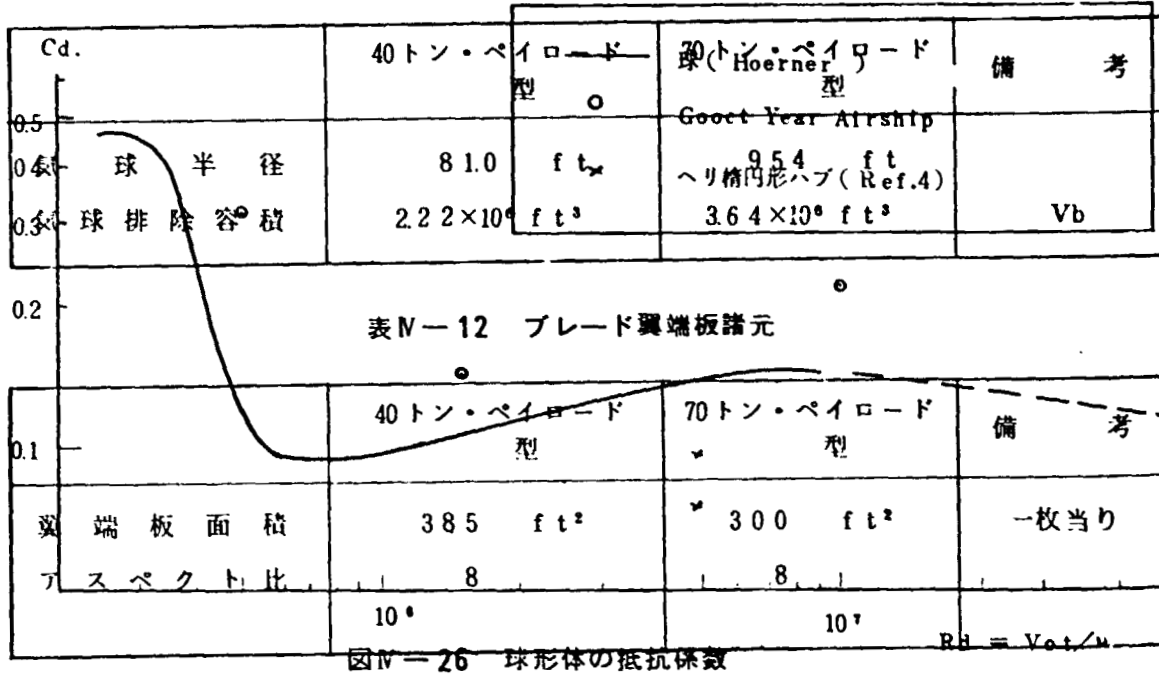

Fig. IV-26. Resistance Coefficient of Ball-Shaped Body

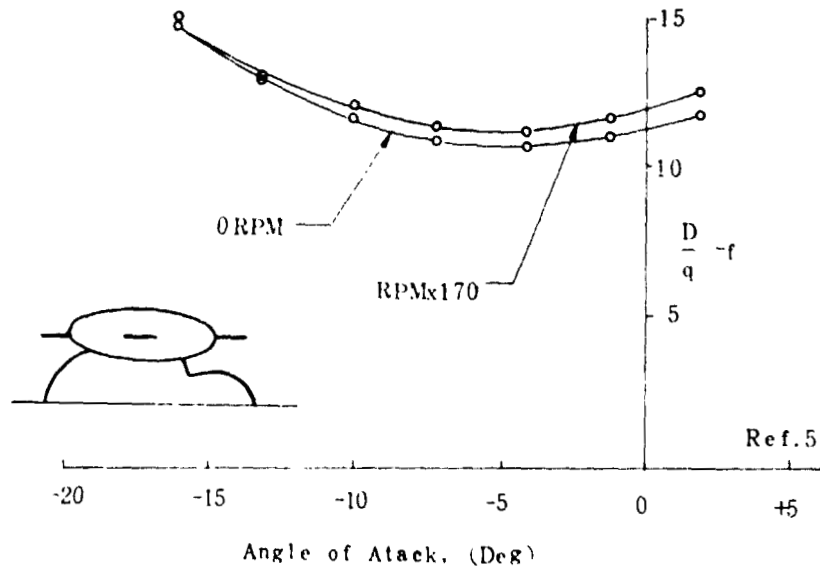

Fig. IV-27. Effect of Rotor Head Rotation on Drag

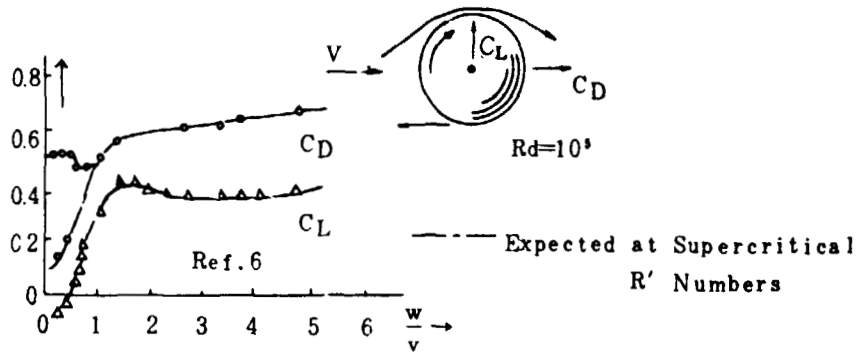

Fig. IV-28. Magnus Force of Rotating Ball

(7) The rotor blades are four constant tension length blades of Wing Type NACA 0012, having no down twist. The shape of the blades are characterized by,

Lift Inclination:	$a = 0.10$ 1/deg,
Minimum Shape Resistance Coefficient:	$\delta_0 = 0.008$, and
Maximum Lift Coefficient:	$C_{Lmax} = 1.7$

Cf. Type NACA0012 is the most used blades among the blades used for helicopters.

(8) The resistance coefficient of the suspended cargo (payload) have been determined as shown in the following figure, using $Ch_0 = 1.2$ and considering the cargo as a ball with a specific weight of 3 g/cm³. Cf. The specific weight of the iron is 8 g/cm³.

**ORIGINAL PAGE IS
OF POOR QUALITY**

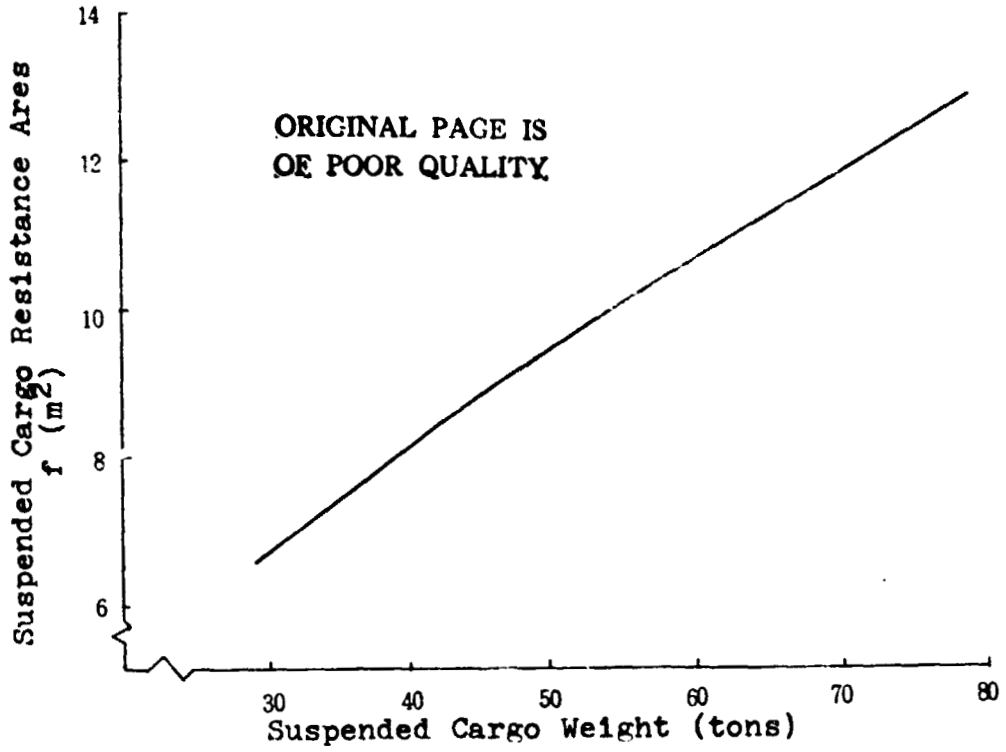

Fig. IV-29. Payload Resistance

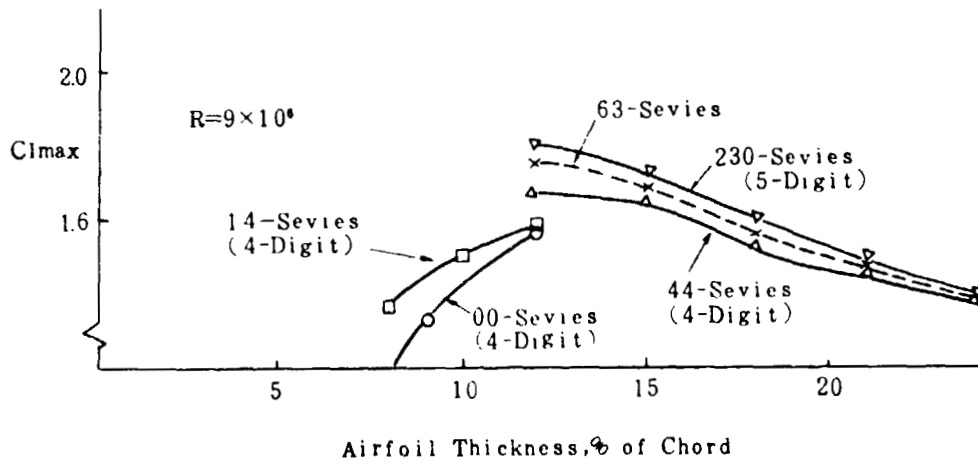

Fig. IV-30. Wing Thickness Ratio and C_{lmax} .

(9) The shape of the winglets which provide horizontal thrust has been determined as follows: The wing type is NACA0012 and constant-length type with the aspect ratio of $AR = 8$. The wing shape is characterized by,

Lift Inclination: $a = 0.10$ 1/deg, and
 Maximum Lift Coefficient: $C_{lmax} = 1.7$ ($\alpha_{max} = 17^\circ$).

Letting the maximum speed of the Skycrane by 1.2 times as high as the maximum cruising speed, $1.2 \times (50 \text{ km/h} + 10 \text{ knots wind}) = 82 \text{ km/h}$ and considering the balance of the thrust (horizontal thrust) and the resistance, the arcs S_w of one winglet is,

$$S_w = \left(\frac{1}{2}\right) \mu^2_{max} \frac{C_a \times S_{ref} + f_{pay}}{a \alpha_{max}} \times \frac{AR + 2}{AR},$$

/18-

where

$C_a = 0.2$,
 S_{ref} : Balloon Front Portion Area,
 f_{pay} : Payload Resistance Area,
 $a \alpha_{max} = 1.7$,
 $AR = 8$, and
 $\mu_{max} = V/\Omega R$. (Cf. V is the forward speed and the ΩR has been determined based on the rotor tip speed.)

(10) The weight of the Skycrane was obtained according to the formulae described in Appendix I.

(11) The engines are turboprop engines with $SFC = 0.3 \text{ kg/eshp/hr}$ and Normal $eshp = 0.81 \times T/\emptyset \text{ eshp}$.

These specifications are based on those of the currently used engines. The engines are placed at the 75% position of each rotor blade outside the balloon. This position corresponds to the node of each blade.

(12) The performance properties may be calculated according to the formulae in Appendix II.

(a) Specifications of Hull Structure.

As mentioned previously, the shapes of the following members have been fixed from the beginning in order to reduce the amount of the calculations:

(i) Rotor Blades.

- (1) Number of Blades: $b = 4$,
- (2) Blade Length: constant,
- (3) Wing Type: NACA0012 (Most Frequently Used in Helicopters),
- (4) The blades do not have down twist, (since the blades must provide up load as well as down load.)

(ii) Blade Winglet.

- (1) Aspect Ratio = 8,
- (2) Winglet Length: constant, and
- (3) Wing Type: NACA0012.

The rotor equivalent shaft power HP rotor has been calculated with R (rotor radius), Ω (rotor angular velocity) and σ (rotor solidity) as variables, where $\sigma = bc/\pi R$ and c is the blade length. In this calculation, the following restrictions have been provided:

Translator's Note: Pages 182 and 178 of the original text have been printed on the same page (overlapping). Neither page is readable, except for Tables IV-10 to IV-12 on Page 182 of the original test.

/182

Table IV-10. Specifications of Rotors.

	40-ton Payload Type	70-ton Payload Type	Symbols
Rotor Radius	150 feet	160 feet	R
Rotation Speed	1.0 rad/s	1.25 rad/sec	
Rotor Solidity	0.1	0.1	
Number of Blades	4	4	b
Blade Length	11.78 feet	12.57 feet	c
Engine Position Radius	132.8 feet	143.85 feet	R _e

Table IV-11. Specifications of Balloon.

	40-Ton Payload Type	70-Ton Payload Type	Symbol
Balloon Radius	81.0 feet	95.4 feet	
Balloon Displacement Volume	2.22×10^6 ft ³	3.64×10^6 ft ³	V _b

Table IV-12. Specifications of Winglets.

	40-Ton Payload Type	70-Ton Payload Type	Remark
Winglet Area	385 ft ²	300 ft ²	per blade
Aspect Ratio	8	8	

Fig. 34 shows required horse power of the designed Skycranes, in which /183 HP_i denotes the induced horse power, HP_o the Blade Shape Horse Power and HP_p the horse power required to move the balloon forward plus the horse power used by the winglets. Table IV-13 shows the assorted weights.

Vertical 0.1 g at Hovering
37 kts Level Flight

70-Ton Payload Type

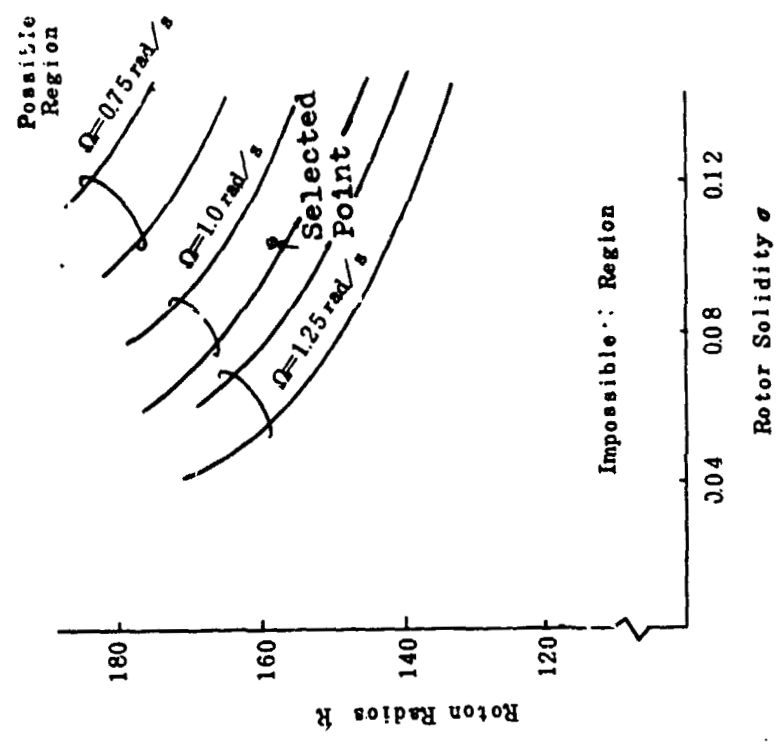

40-Ton Payload Type

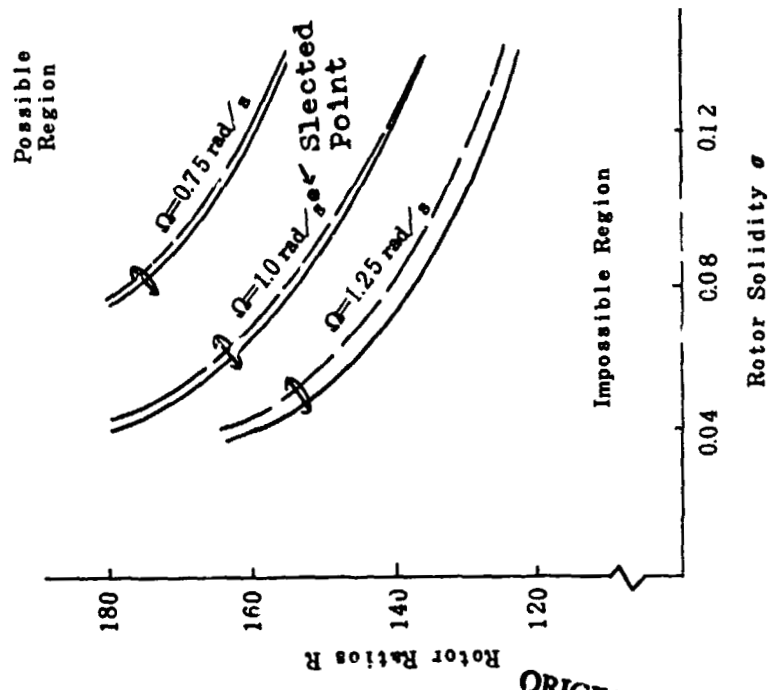

Fig. IV-31. Shape Design Curve.

ORIGINAL PAGE IS
OF POOR QUALITY

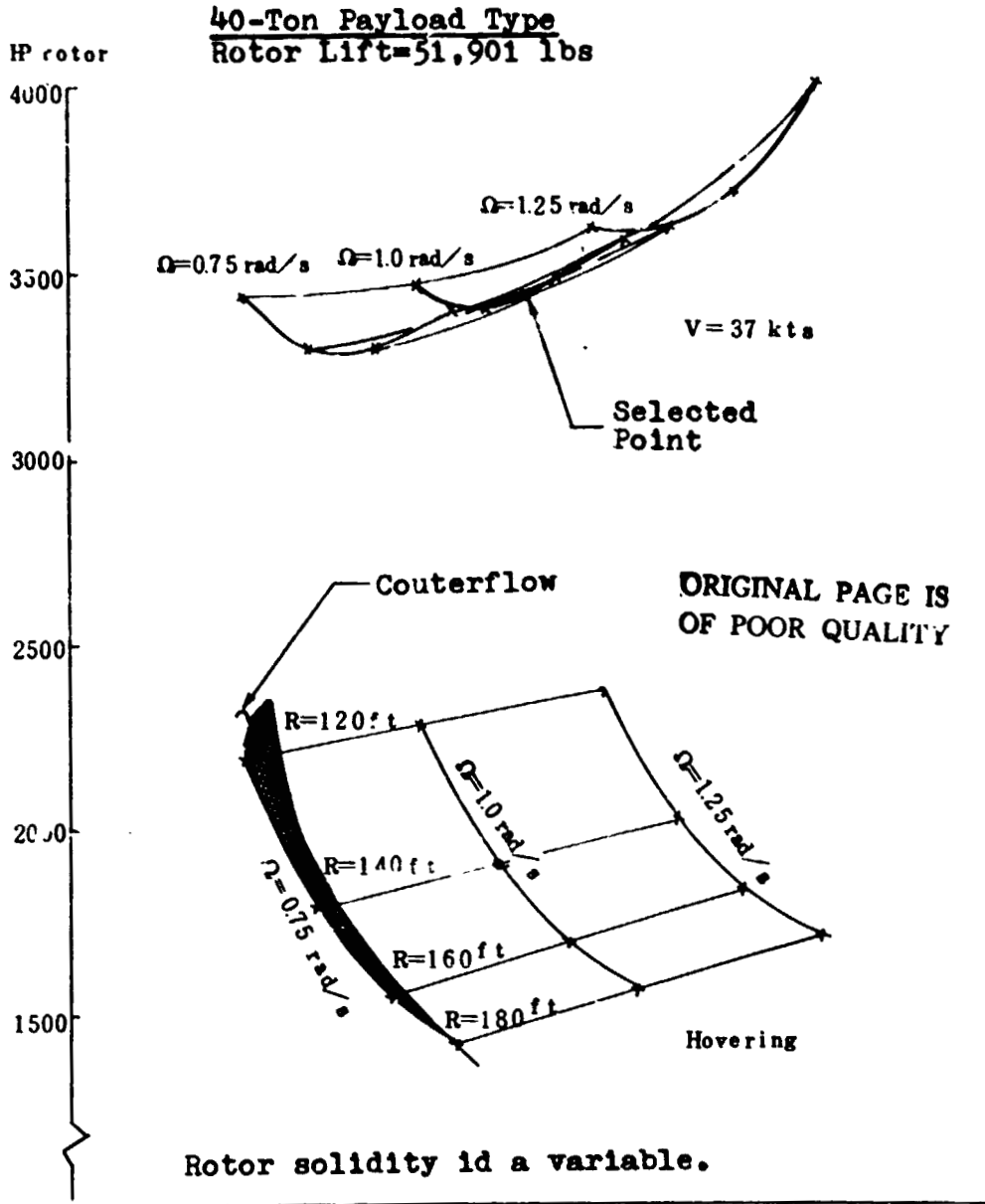
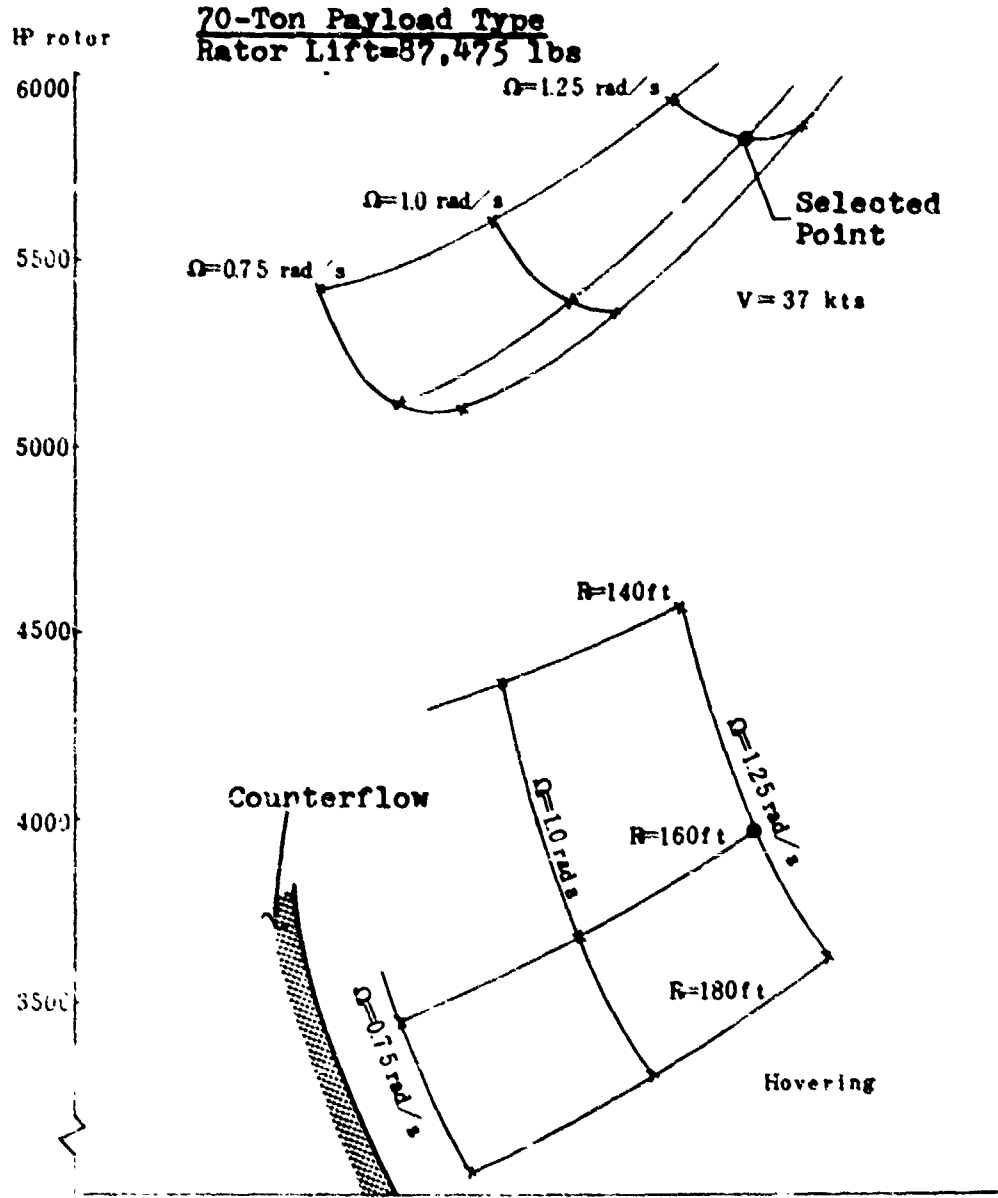

Fig. IV-32. Shape Design Curve.



Note: Rotor Solidity is a Variable.

Fig. IV-33. Shape Design Curve.

414 ↓

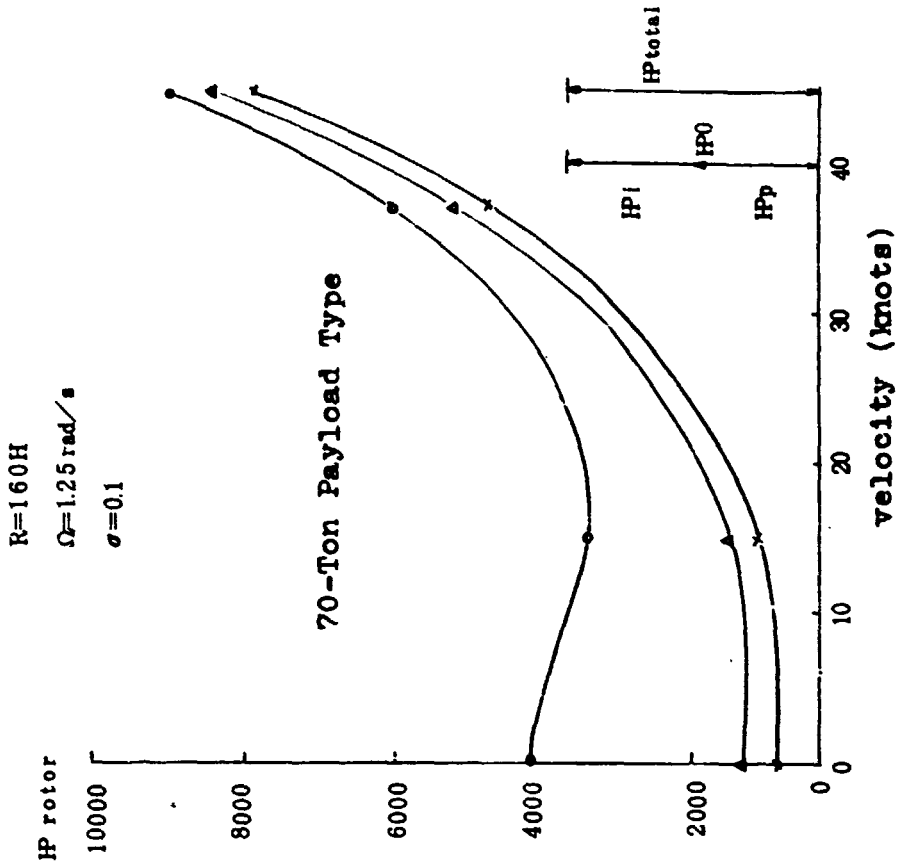

**ORIGINAL PAGE IS
OF POOR QUALITY**

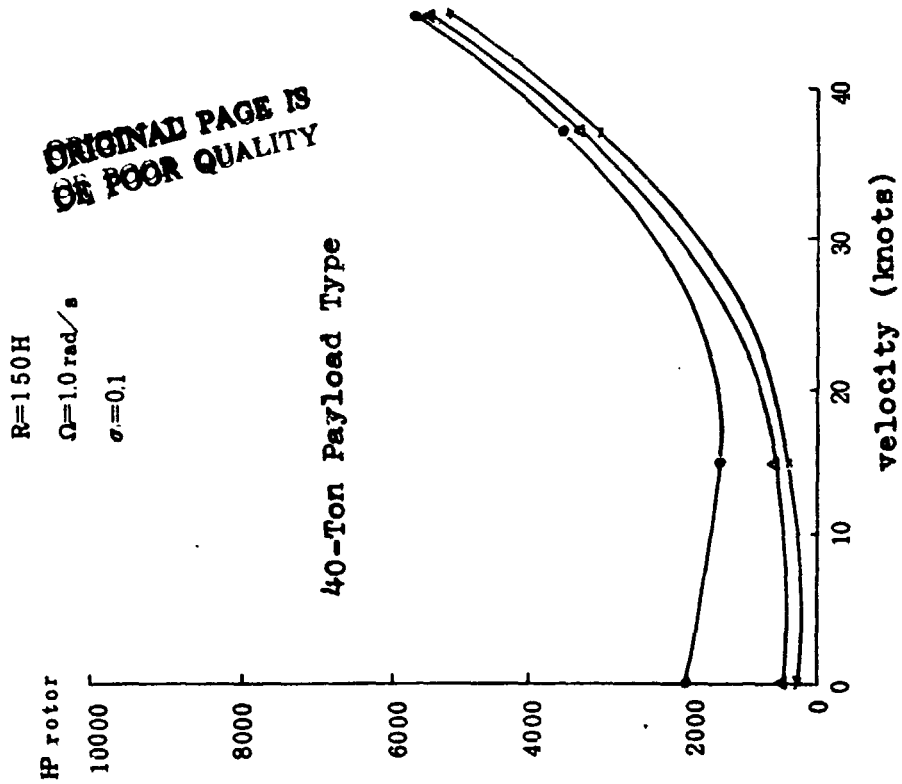

Fig. IV-34.

Table IV-13. Assorted Weights of the Skycrane.

	40-Ton Payload Type	70-Ton Payload Type	Remarks
Rotor Lift (kg)	23,538	39,671	Ny5010 Output
Balloon Buoyancy (kg)	51,258	83,814	
Gross Weight (kg)	74,796	123,485	
Balloon Radius (m)	24.68	29.07	
Rotor Radius (m)	45.72	48.77	
Balloon Displacement Volume (m ³)	62,975	102,966	
Outer Coverings Ws (kg)	1,410	1,958	
Balloon Wires Waw (kg)	413	676	
Blades Wb (kg)	7,671	12,106	
Blade Supporting Wires Wbw (kg)	1,100	1,977	
Side Beams Wsb (kg)	4,222	8,383	
Central Pole Wcb (kg)	1,154	2,301	
Others Wm (kg)	4,754	8,154	
Swivel Joint Wsj (kg)	940	1,298	
Crane Wll (kg)	1,232	2,156	
Power Wpow (kg)	5,336	8,000	

Gondola Wg (kg)	3,000	3,000	
Operators (kg)	272	272	
Fuel (kg)	4,283	6,989	(*)
Payload (kg)	39,004	66,215	
Useful Load (kg)	43,559	73,476	
Dead Weight (kg)	31,237	50,009	
Rotor Lift Allotment	0.540	0.540	$\frac{\text{Rotor Lift}}{\text{Useful Load}}$

* 150 km of Flight + 30 Min. of Hovering + Margin.

(b) Specifications of Engines and Propellers.

The engines are turboprop engines. In determining them, the Hamilton Standard was used. (Cf. Ref. 8) The relationship among the propeller efficiency η_p , the Skycrane equivalent axial horse power H_{Protor} and the C_p of the Hamilton Standard is:

$$C_p = \frac{137.5 \times H_{\text{Protor}}}{\rho n^3 D^5 \times \eta_p (\psi)} \times (1 + \mu \sin \psi),$$

where

$$\mu = \frac{V}{\Omega R_e},$$

R_e = Engine Position Radius (feet),

V = Forward Speed (feet/s) of the Skycrane,

Ω = Rotor Rotation Angular Velocity (rad/s),

ψ = Anticipated Attachment Angle of Engines With Respect to the Blades (The leeward is designated by $\psi = 0$ and the angle ψ is measured along the rotor rotational direction),

$\eta_p (\psi)$: The Propeller Efficiency at the Angle ψ ,

H_{Protor} = The Horse Power Which is Converted from the Torque Required to Rotate the Skycrane with Efficiency 1.0,

/189

ρ = Air Density (Slug/feet³),
 n = Rotational Speed of Propellers (rps), and
 D = Propeller Diameter.

When the propeller diameter was calculated according to this formula, such a large value was obtained that the propellers cannot be installed. Therefore, considering the upper limit of the propeller diameter from the viewpoint of the design, D = 20 feet was decided. The upper limit of the blade tip Mach number was decided to be suppressed to 0.6, considering the noise.

In addition, in order to reduce the amount of calculation, four-blade propellers were selected over three-blade propellers, in the Hamilton Standard.

Table IV-14. Specifications Propeller.

	40-Ton Payload Type	70-Ton Payload Type	Remarks
Number of Propeller Blades	4	4	
Activity Factor	80	80	
Integrated Design Cli	0.30	0.30	
Propeller Rotation Speed	10.66 rps	10.66 rps	
Propeller Diameter	20 feet	20 feet	
Propeller Average Efficiency (*)	0.82	0.877	At Hover- ing (*)
p	0.77	0.83	At 37 knots (*)

(*) At sea level and on standard day.

The relationship between the Eshp of the turboprop engine and the HProtor which is mentioned previously is,

$$Eshp = \frac{HProtor}{4 \times \eta_p} \times (1 + \mu \sin \psi), \text{ and}$$

its average is,

$$\overline{E_{ship}} = \frac{H_{Protor}}{4 \times \bar{\eta}_p}$$

/190

The T/ø power of the engine is obtained by,

$$T/\delta \text{ Power} = (\overline{E_{ship}})_{max} / 0.81.$$

The HProtor is determined by Fig. IV-34 at (50 km/h + 10 knots wind) = 37 knots, and then T/ø power is selected to be 1.3 times as much as $(\overline{E_{ship}}) / 0.81$ in order to obtain some margin. (A too large value will be obtained if the T/ø power at 37 knots x 1.2 is used.)

Table IV-15. Engine T/ø Power

	40-Ton Payload Type	70-Ton Payload Type
T/ø Power	1,800 HP	2,800 HP

Table IV-16. Weight of Power Equipment.

	40-Ton Payload Type	70-Ton Payload Type	Remarks
Engines (kg)	650 x 4	943 x 4	Weg
Control Means (kg)(etc.)	253 x 4	381 x 4	Wpp
Propellers (kg)	220 x 4	329 x 4	Wprop
Nacelle (kg)	211 x 4	347 x 4	Wnac
Total (kg)	5,336	8,000	Wpow

Note: The number of engines is four.

The payload and the flight distance are discussed in Section (a) and whether the Skycrane can ascend up to the 1,000-m altitude in Section (b). In Section (c), discussions concerning one-unit engine failure will be done.

(a) Payload and Distance of Cruise.

Fig. IV-35 plots the relationship between the payload and the distance of cruise in case that the cruising speed is 50 km/h (with 10 knots of wind).

As the payload is decreased, the rotor blade pitch angles approaches to be flat, and hence, the distance of cruise is increased due to the decrease in the required horse power. As the payload is further decreased, however, the rotor must provide down load, and hence, the distance of cruise is decreased.

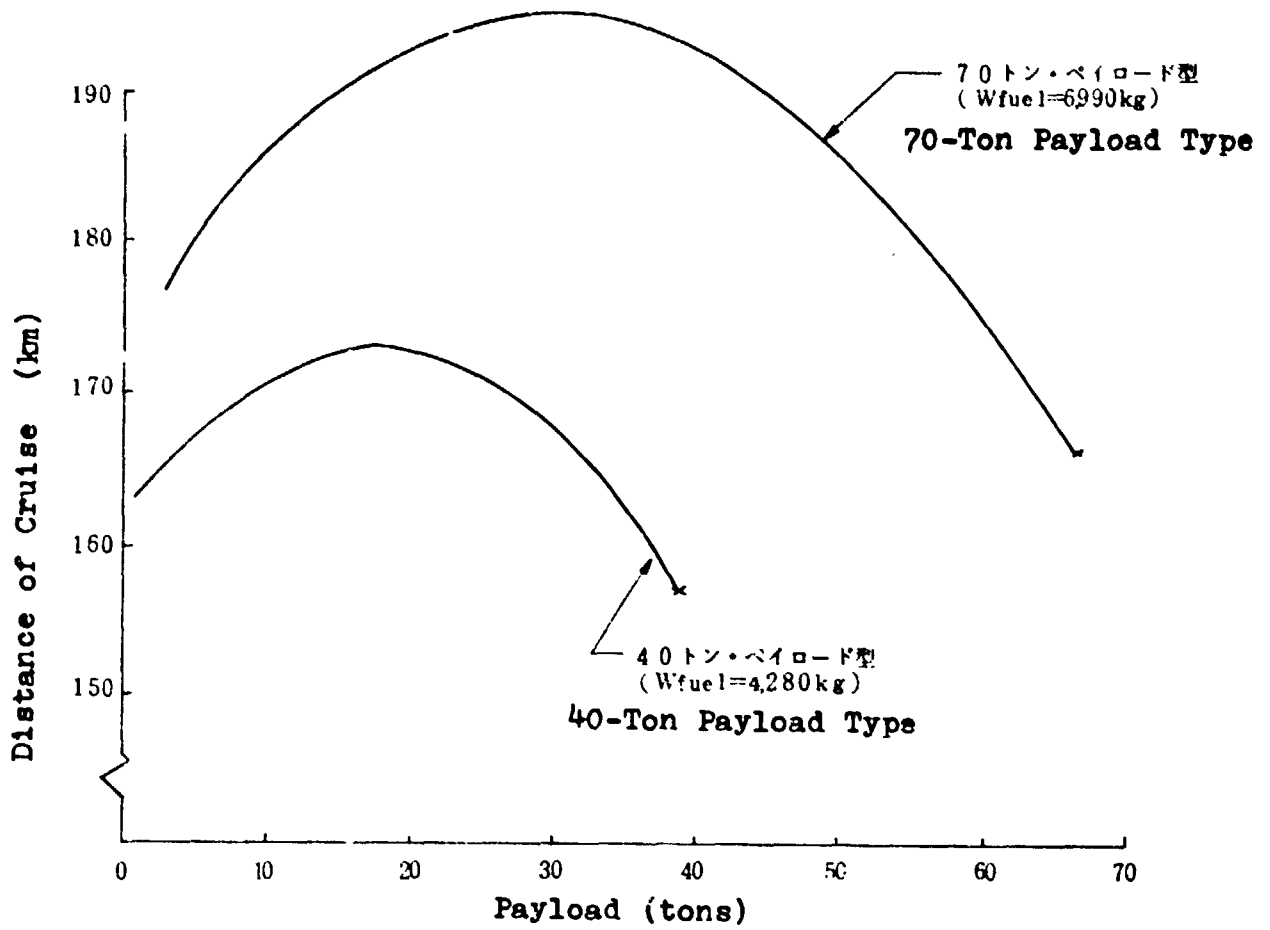

Fig. IV-35 Payload~Range

Cruising Speed: 50 km/h (wind speed; 10 kts)

At Sea Level on Standard Day

(b) Ascending Performance.

In order to see whether the Skycrane can ascend to the altitude of 1,000 m at 50 km/h (with 10 knots of wind), the required horse power of the turboprop engines has been discussed using Fig. IV-36.

Table IV-17. Required Horse Power at H = 1,160 m.

	40-Ton Payload Type	70-Ton Payload Type	Remarks
Propeller Efficiency η_p	0.77	0.83	At H=1,160 m
HPreq at H=1,160 m	1,040 HP	1,640 HP	per one turboprop engine
Engine Take-Off Power	1,800 HP	2,800 HP	at S.C. per one engine

As seen in the above table, the engine horse power is sufficient, even when the engine available power is decreased as ascending to the altitude of about 1,000 m.

(c) Sudden Failure of One Engine.

Fig. IV-36 shows that,

$$H_{\text{Protor when Hovering}} < (3/4) \times H_{\text{Protor at 37 knots.}}$$

Therefore, the hovering is possible even when one of the engines fails suddenly.

IV-4-4 Stability.

The discussion in this section is only with regard to the 40-ton payload type.

The maximum possible g when hovering; the dynamic characteristics when forwardly travelling and the damping and the control power when hovering have been studied and the results will be shown in Sections (a), (b) and (c), respectively.

(a) Maximum g when Hovering.

The maximum possible g in the horizontal and the vertical directions when hovering (at sea level in a standard day) will be described in this section:

(1) Horizontal Maximum g.

The winglet area has been selected so that the Skycrane may travel forwardly overcoming the resistance even at the maximum speed (which is 1.2 times as high as the maximum cruising speed considering the wind of 10 knots). The winglets can thus provide the thrust of 27,380 lbs.

The mass (including the apparent mass and the payload) of the Skycrane is,

$$m = 2,670 + 3,050 + 2,647 = 8,368 \text{ Slug,}$$

and hence, the maximum horizontal g when hovering is,

$$g = \frac{27,380}{8,368 \times 32.2} = 0.10.$$

ORIGINAL PAGE IS
OF POOR QUALITY.

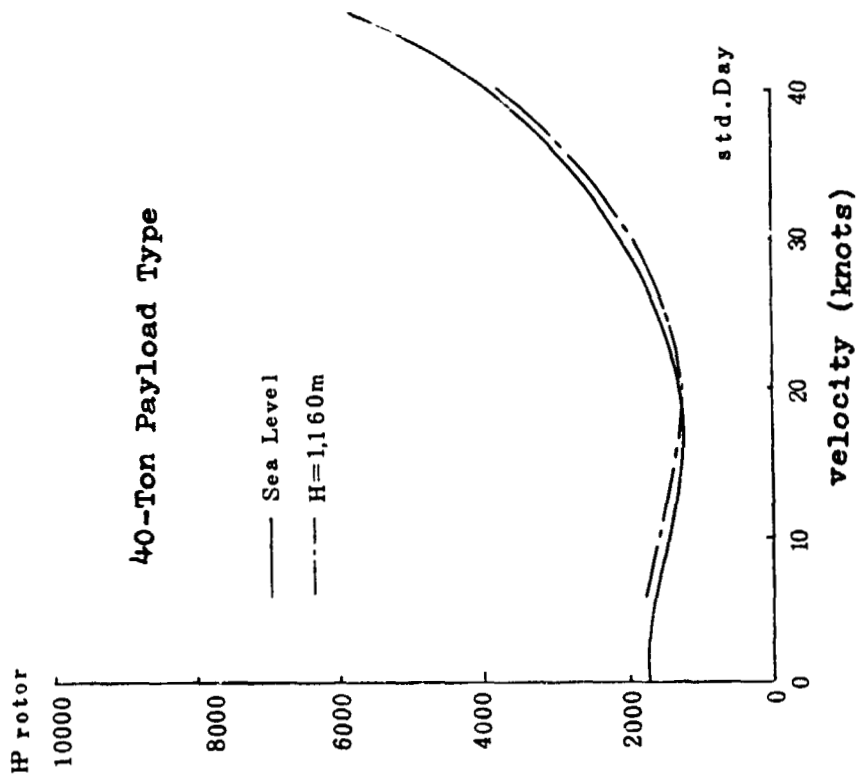
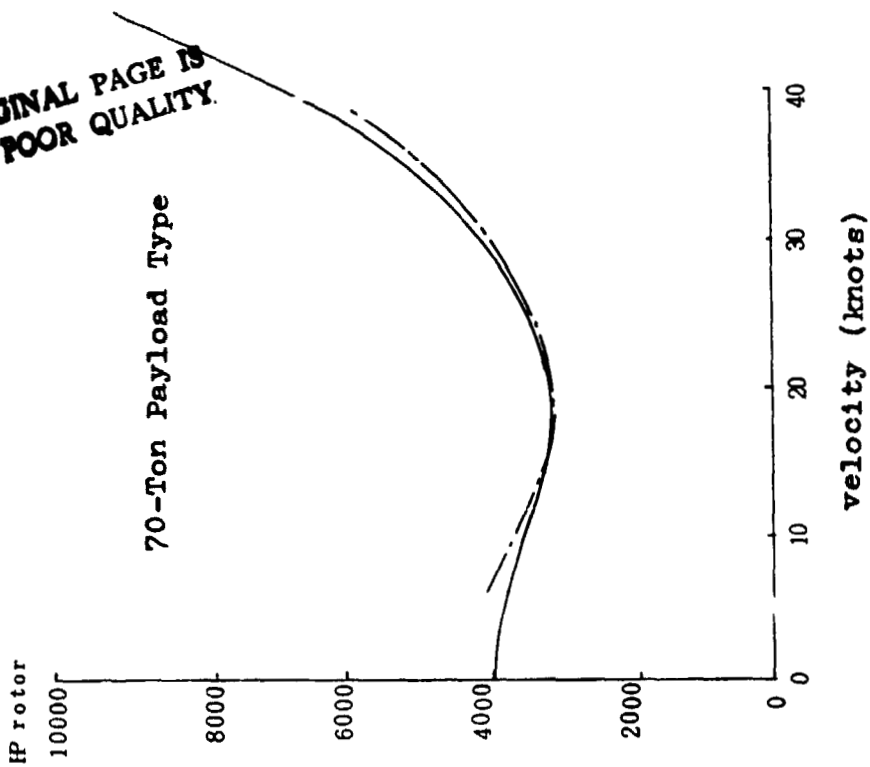

Fig. IV-36.

If the calculation is done ignoring the payload,

/194

$$g = \frac{27,380}{5,697 \times 32.2} = 0.15.$$

(2) Upward Maximum g.

The rotor thrust when hovering is represented by,

$$\frac{2C_T}{a\sigma} = t_3 \theta_0 + \lambda_0 t_2,$$

where

$$\lambda_0 = -\sqrt{\frac{C_T}{4t_2}}$$

The blade terminal elevation angle α_T is,

$$\alpha_T = \theta_0 + \lambda_0.$$

It follows from the above that the trim value is $\theta_0 = 0.2945$ rad, $\lambda_0 = -0.09834$, and $\alpha_T = 17^\circ$. The C_T appears at t_{10}

= -0.1226, and the increase ΔT in the thrust at $C_T = 0.02130$ is,

$$\Delta T = 51,901 \times \frac{0.02130 - 0.01371}{0.01371}$$

$$= 28,720 \text{ lbs,}$$

and the vertical g when hovering is,

$$g = \frac{28,720}{8,368 \times 32.2} = 0.1066.$$

Consequently, the Skycrane has the ability of providing the acceleration higher than 0.1 g both in the horizontal and in the vertical directions when hovering.

Note: Although the rotor blade tip loss coefficient $B = 1.0$ in the calculation of the performance properties and in this section, $B = 0.97$ is used in the analyses of the stability in the following sections. (Probably, the actual B is almost 1.0 since the blades are

provided with the end plates.) It is for this reason that the trim value in Fig. IV-37 is different from that θ_0 which appears in these sections.

(b) Dynamic Characteristics When Moving Forwardly.

The dynamic characteristics when moving forwardly have been calculated according to the formulae shown in Appendix III. The main assumptions necessary for deriving those formulae are:

- (1) The payload is 40 tons,
- (2) The rotor is fixed by blade supporting wires and can be regarded as a perfectly rigid body which never flaps,
- (3) The movement can be decomposed into the vertical and horizontal movements, /195
- (4) The skycrane can be regraded as two bodies, the main body (including the gondola) and the payload which is assumed to swing around the main body,
- (5) The center of gravity of the Skycrane main body is assumed to be identical with that of the balloon, (a ball), i.e., the center of the balloon.
- (6) The motions are calculated by considering the perturbations of the displacements, and
- (7) The Magnus force applied to the balloon is 0.6 times as much as the resistance.

The results of the calculations are shown in Fig. IV-37 through IV-43:

Fig. IV-37: The trim values are shown, where θ_0 is the rotor corrective/cyclic pitch which is represented by,

$$\theta = \theta_0 - A_{is} \cos \psi - B_{is} \sin \psi,$$

where ψ is measured from the downstream in the counter clockwise direction, and θ_T is the blade tip

plate pitch angle which is represented by,

$$\theta = \theta_T \cos (\psi + \epsilon).$$

Figs. IV-38 and IV-39: The oscillatory roots of the horizontal and the vertical directions are compared with the MIL-F-83300 Level 1 at various speeds (with the SAS being off).

Figs. IV-40 to IV-43: The oscillatory roots of the horizontal and the vertical directions are compared with MIL-F-83300 Level 1 when the damper strength is varied (with the SAS being on), at $V = 5, 37$ knots.

As seen from these figures, the ship body is unstable when the SAS is off (there are non-oscillatory unstable roots.).

When being equipped with the SAS, the vertical stability satisfies the MIL-F-83300 Level 1 at $V = 65$ km/h (= 35 knots).

In the horizontal direction, the Level 1 cannot be satisfied, but the Level 2 is attained. (See Fig. IV-41.)

It should be noted that the structure of the SAS considered in this analysis is very simple (as shown in the following diagram) and should be re-considered in the further studies.

Block Diagram of SAS

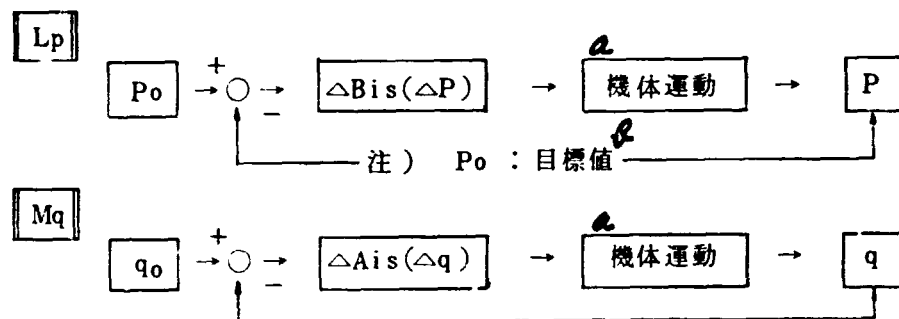

Key: a: Ship Body Movement

b: Reference Value

ORIGINAL PAGE IS
OF POOR QUALITY

ORIGINAL PAGE IS
OF POOR QUALITY

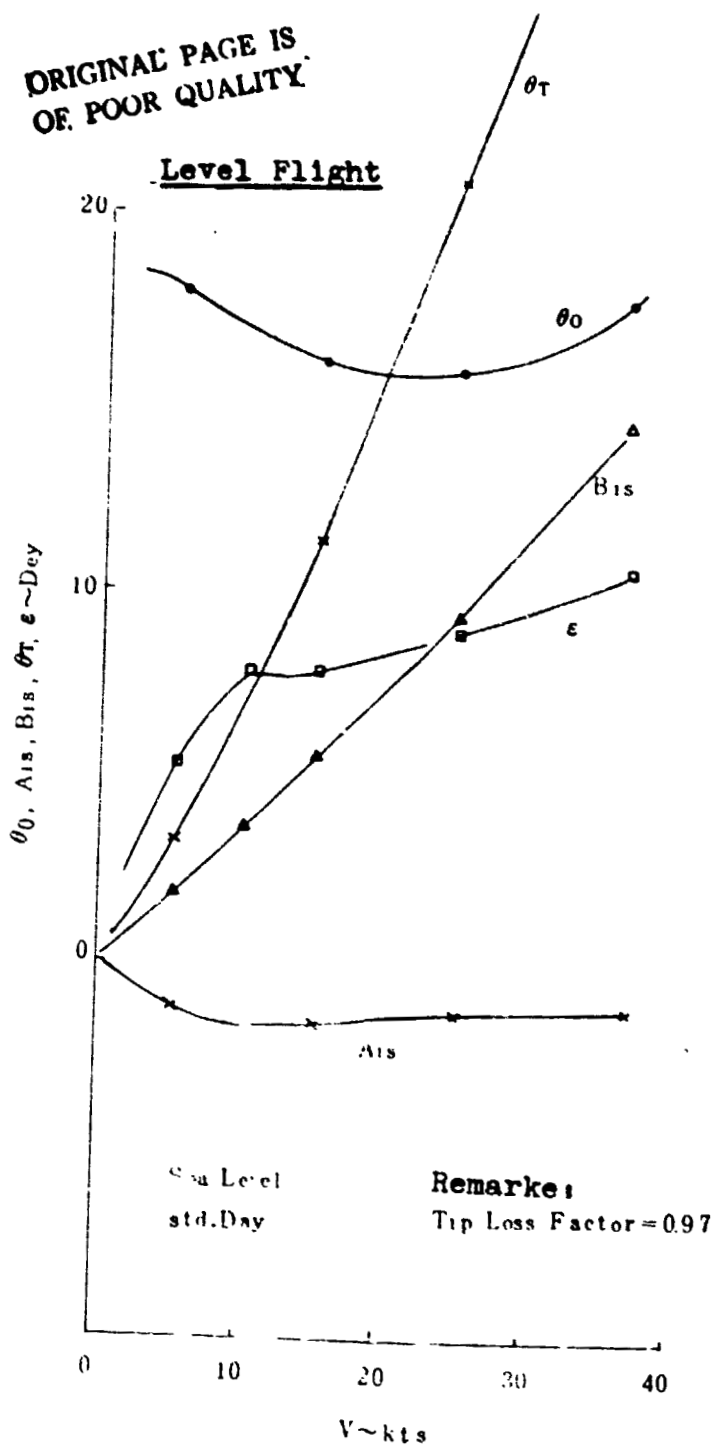

Fig. IV-37. Trim Value of the Skycrane
(40-Ton Payload Type)

MIL-F-83300

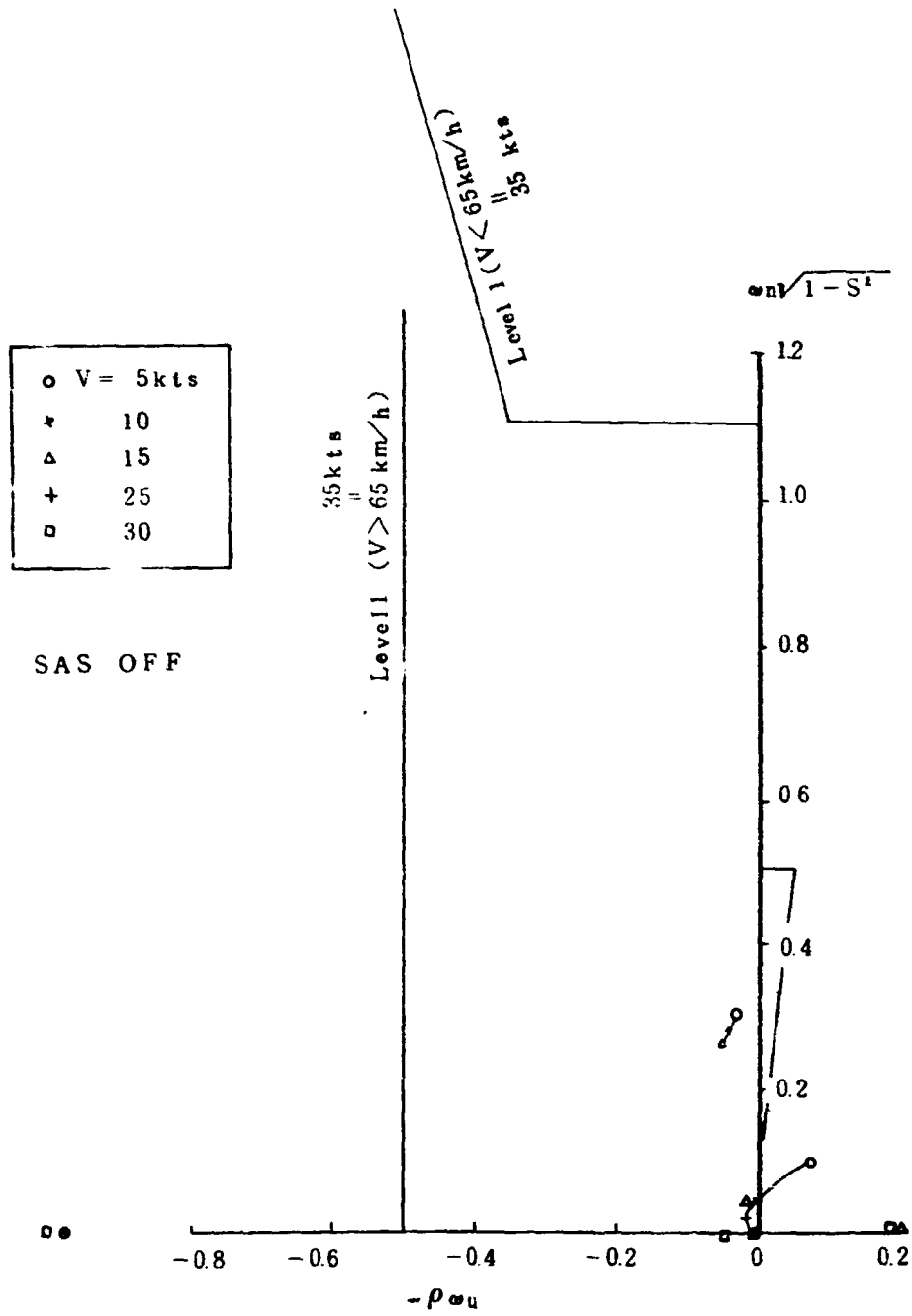

Fig. IV-38. Lateral Oscillation Roots at Various Velocities.

ORIGINAL PAGE IS
OF POOR QUALITY

ORIGINAL PAGE IS
OF POOR QUALITY

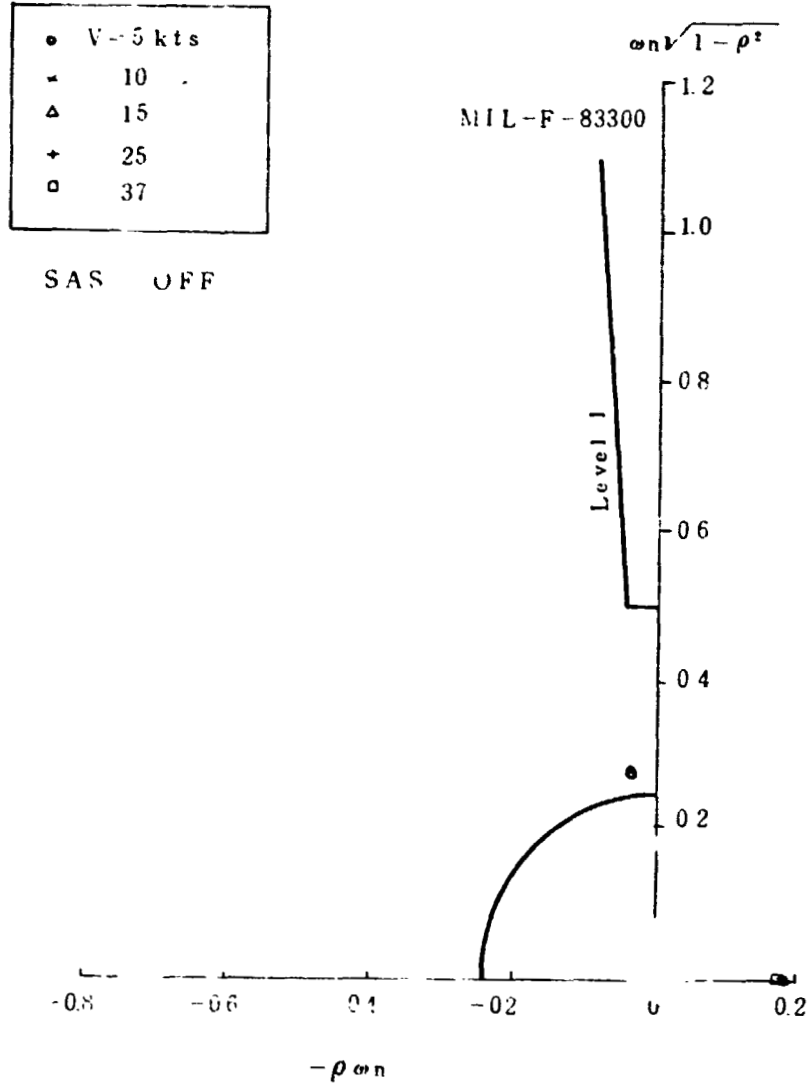

Fig. IV-39. Traverse Oscillation Roots.
at Various Velocities.

MIL-F-83300

ORIGINAL PAGE IS
OF POOR QUALITY

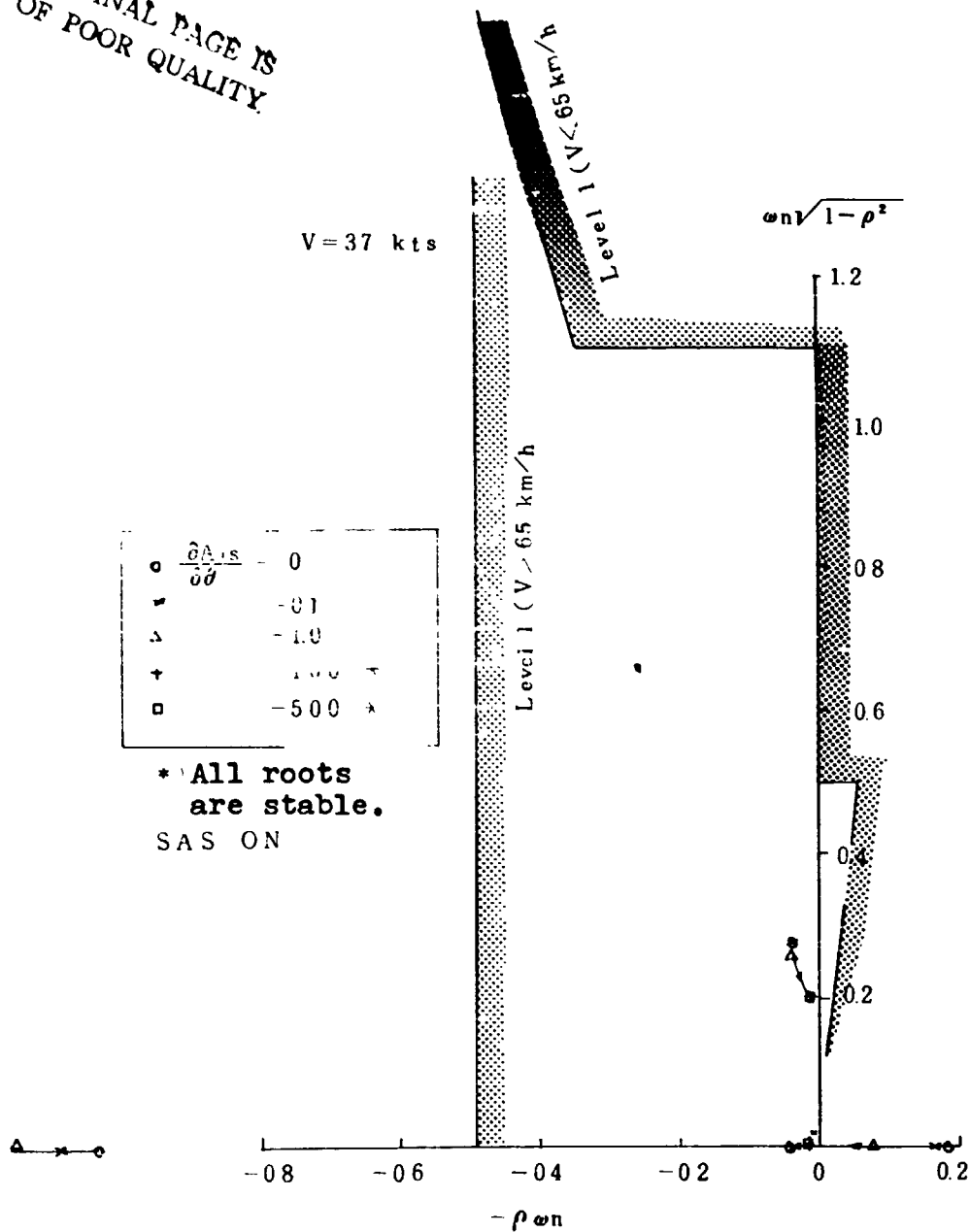

Fig. IV-40. Pitch Damper and Lateral Oscillation Roots.

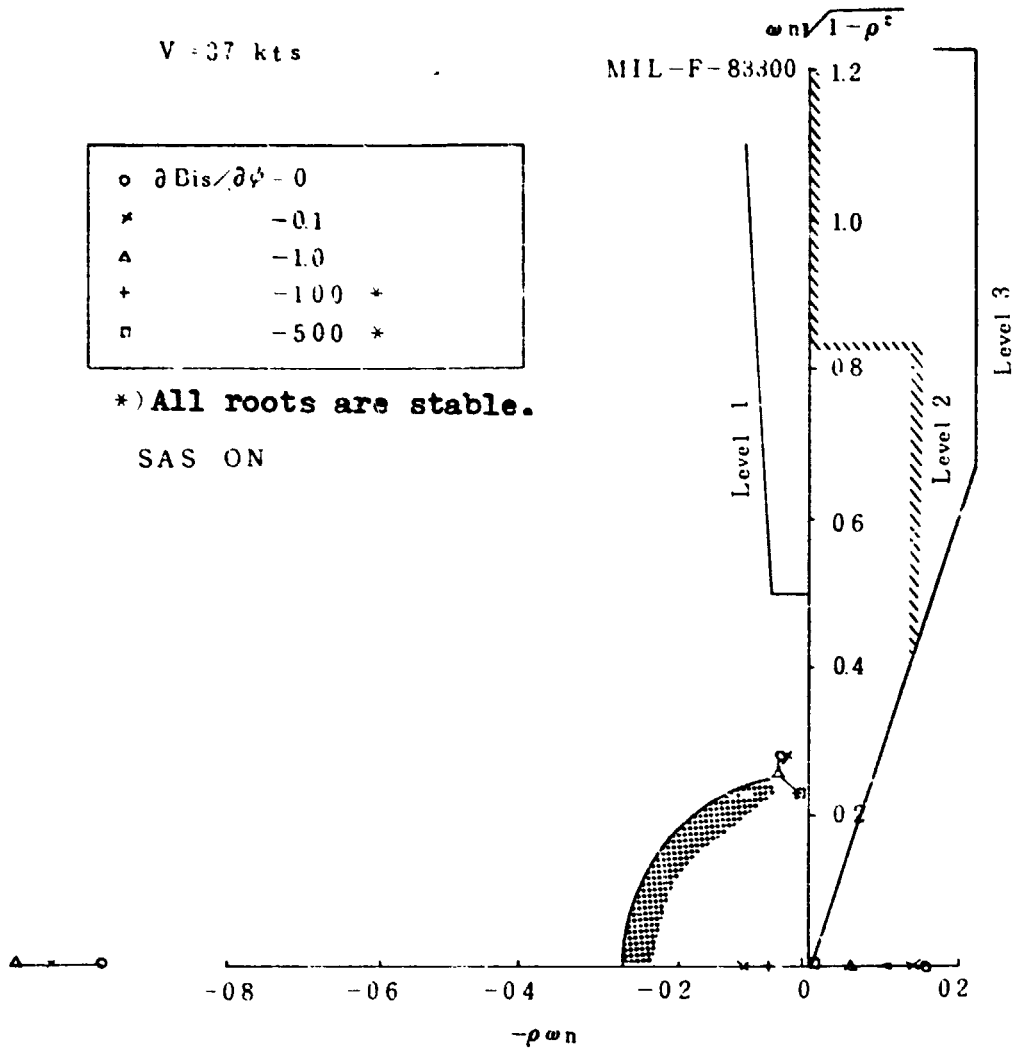

Fig. IV-41. Roll Damper and Traverse Oscillation Roots.

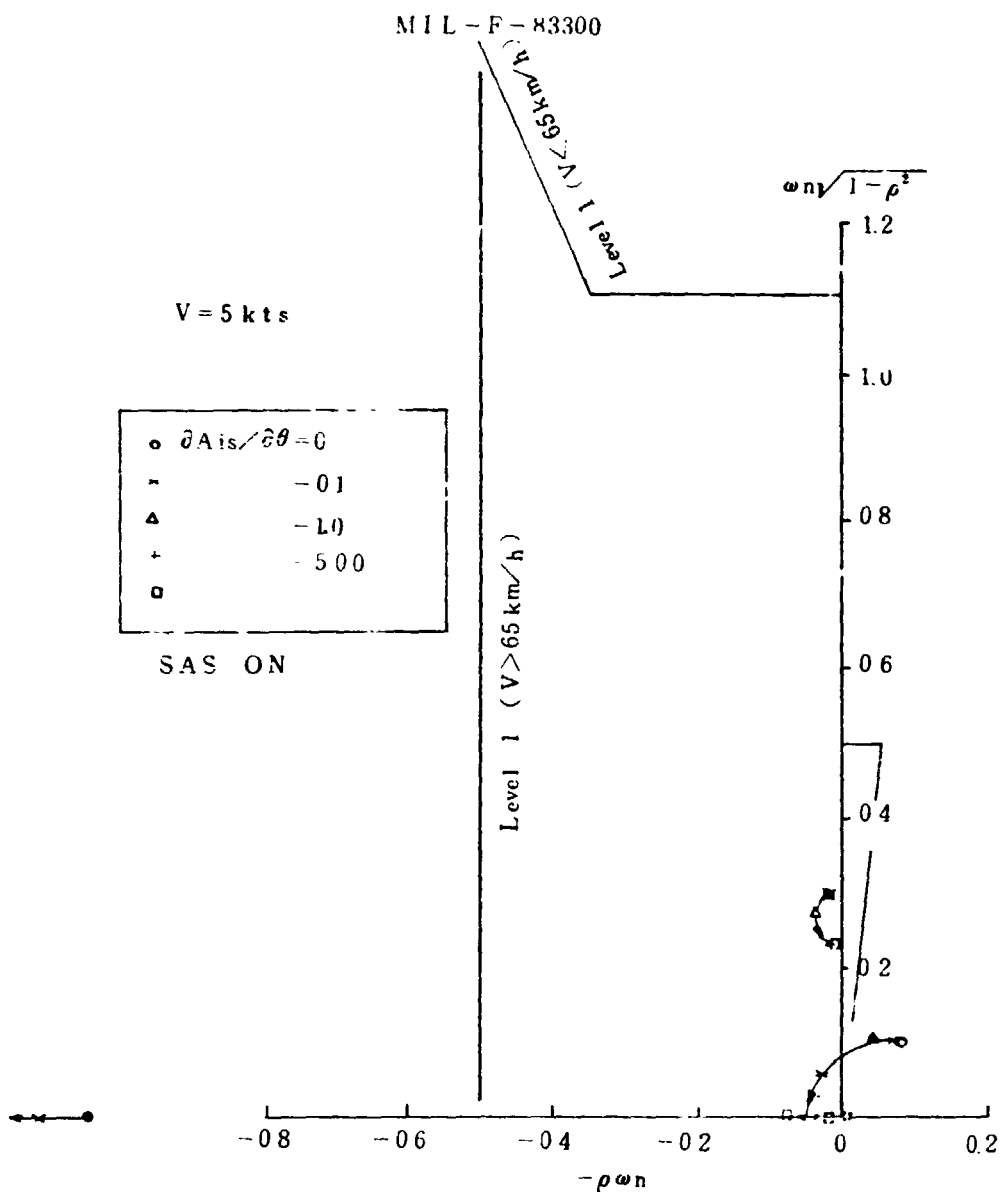

Fig. IV-42. Pitch Damper and Lateral Oscillation Roots.

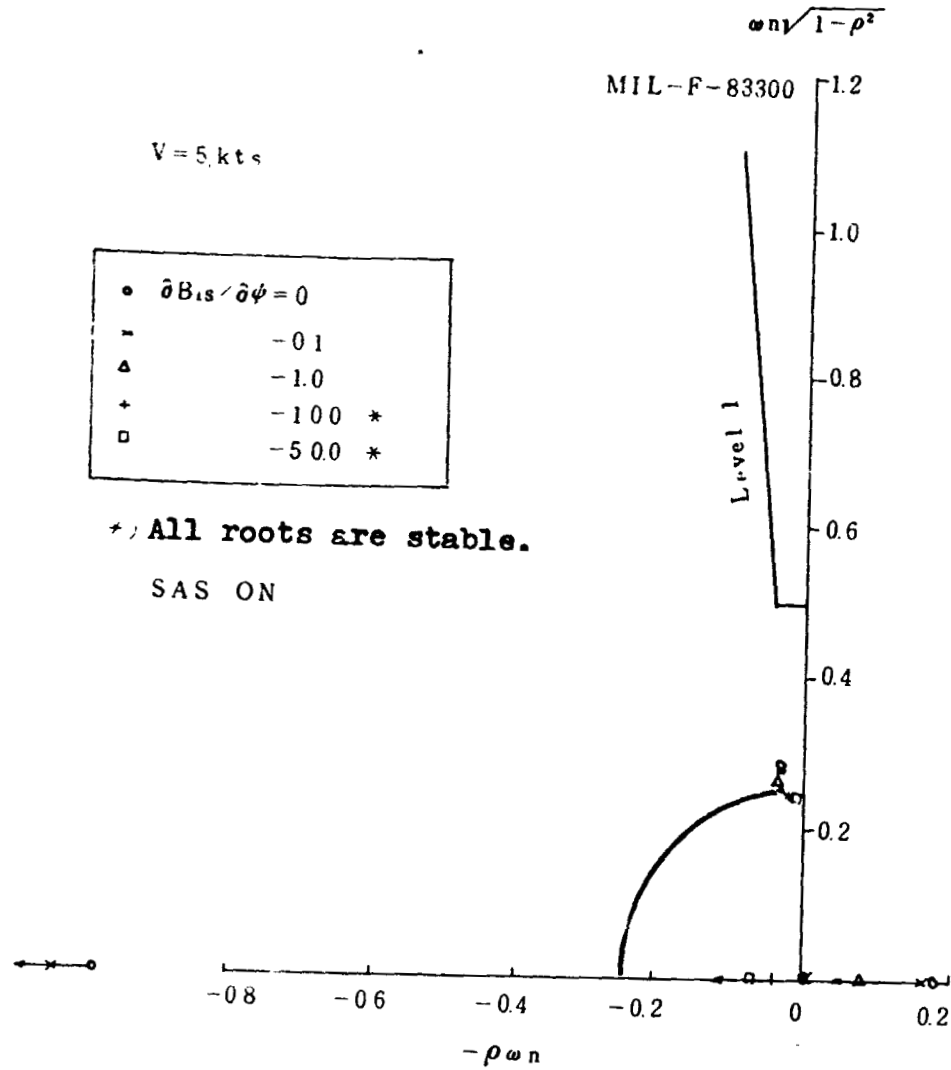

Fig. IV-43. Roll Damper and Traverse Oscillation Roots.

ORIGINAL PAGE IS OF POOR QUALITY.

The pitch damping when hovering is represented approximately by,

$$\frac{\partial M}{\partial q} = - \frac{t_4}{2\Omega} \times \frac{a\sigma}{2} \times \rho \pi R^3 (\Omega R)^2,$$

when the SAS is off, which is followed by,

$$\begin{aligned} \frac{\text{Pitch Damping}}{\text{Inertia}} &= \frac{\partial M / \partial q}{I} \\ &= \frac{-16,266,850}{4,169,344 + 1,279,134 + 37,186,159 + 6,819,972} \\ &= -0.33 \text{ 1/s.} \end{aligned}$$

On the other hand,

$$\frac{\partial M}{\partial A_{is}} = \frac{t_4}{2\Omega} \times \frac{a\sigma}{2} \times \rho \pi R^3 (\Omega R)^2.$$

Hence, when the cyclic pitch A_{is} or B_{is} varies within the range of $\pm 25^\circ$ (40-ton payload type), the pitch control/inertia is,

$$\frac{\text{Pitch Control}}{\text{Inertia}} = \frac{\partial M / \partial A_{is}}{I} \Delta A_{is} = 0.141 \text{ 1/s}^2.$$

The result of the calculation is shown in Fig. IV-44. One can see that the pitch control when hovering is better than that of the Heli-Ship.

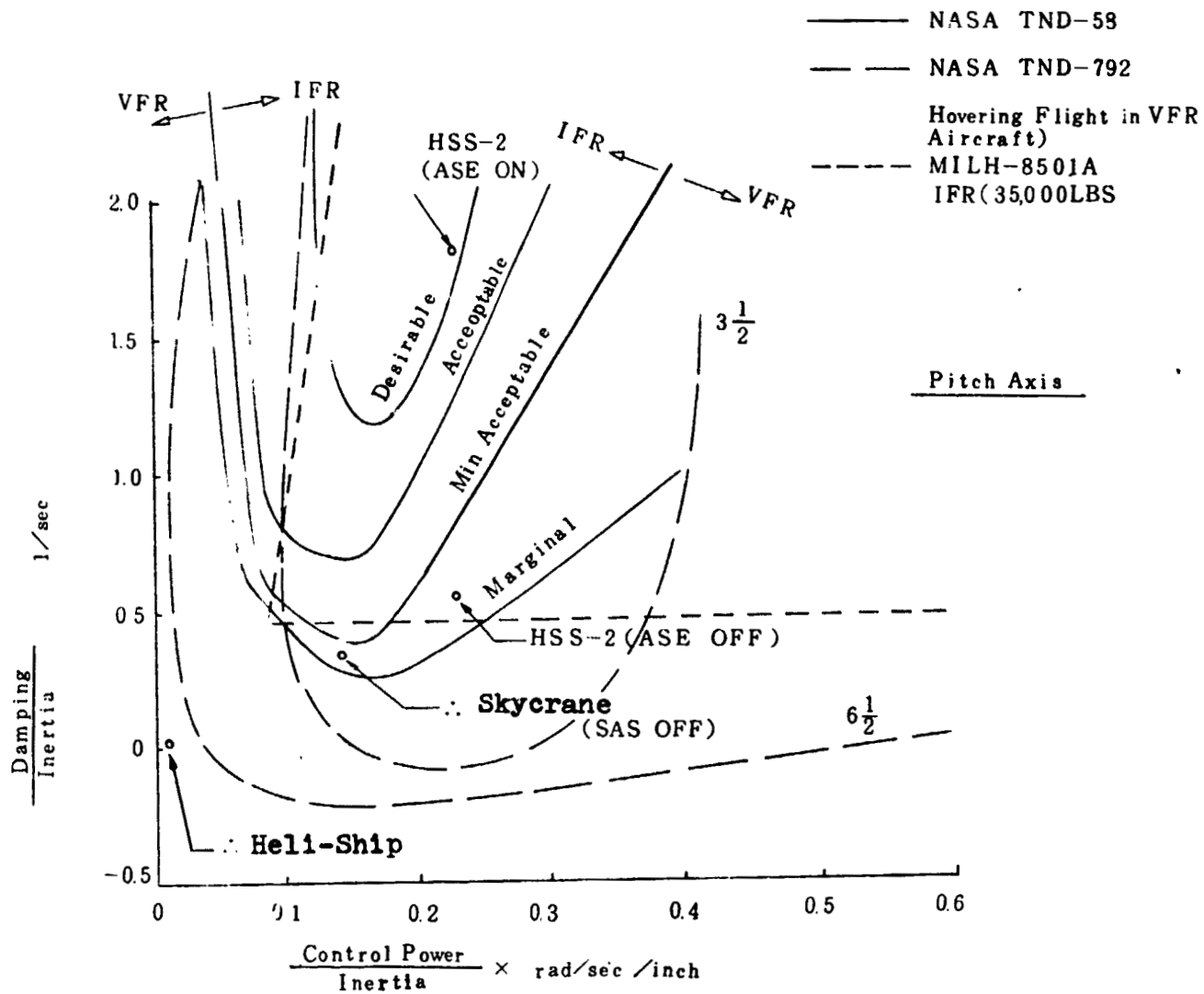

Fig. IV-44. Control Moment and Damping When Hovering.

ORIGINAL PAGE IS
OF POOR QUALITY

1. Azuma, Akira, "Future of airships, " Transaction of the Japan Society of Aeronautics and Space 24/270. (in Japanese),
2. Akiba, Ryotaro, "Re-evaluation of airships," Transaction of the Japan Society of Aeronautics and Space 23/253 (in Japanese)
3. The Japan Association for the Promotion of Machinery, "Survey studies on LTA aircraft systems."
4. Rotorcraft Parasite Drag, Special report presented to the 31st American Helicopter Society Annual National Forum.
5. Olson, J.R., et al., "Wind tunnel data and analysis of full scale rotor head and pylon drag investigation," Sikorsky Engineering Report No. 61027.
6. Howener, Sighard F., 'Fluid dynamic drag.'
7. Payne, P.R., "Helicopter dynamics and aerodynamics."
8. Hamilton Standard, "Generalized Method of Propeller performance estimation," PDB 6101, Revision A, June 1963.
9. Perkins, Russel G., Jr. et al., "Aerocrane, a hybrid LTA aircraft for aerial crane applications, "Proceedings of the Interagency Workshop on Lighter Than Air Vehicles, 1975.
10. Nichols, J.B., et al., "Hybrid aircraft for heavy lift," the 30th Annual National Forum of the American Helicopter Society.
11. Elias, Antonio L., "Wing-tip-winglet propulsion for Aerocrane type hybrid lift vehicle," AIAA Paper No. 75-944. /200
12. Wheatly, J.B., "Simplified aerodynamic analysis of the cyclogyro rotating-wing system," NACA TN 467, July 1933.
13. All American Engineering Company, "The aerocrane - a new concept in ultra-heavy vertical lift."
14. Seckel, Edward, "Stability and control of airplanes and helicopters."
15. Lucassen, Louis R. et al., "Dynamic stability analysis of a hovering helicopter with a sling load," J. of the American Helicopter Society, 10/2.
16. Nielsen, Jack N., "Missile aerodynamics," McGraw-Hill Book Company.
17. Motoyoshi, Seizo, "Dynamics of ship body movement," Lecture Series of Applied Dynamics, Kyoritsu Printing Company, (in Japanese).

18. MIL-F-83300 Military Specification, "Flying qualities of piloted V/STOL aircraft."
19. NA-13661, "Conceptual studies of Mitsubishi's Heli-Stat."
20. YET 73036, "Report of Hss-2 flight characteristics."

IV-4-6. Methods of Operation.

/207

When the Skycrane is used for heavy cargo transportation, a base should be constructed and the Skycrane is operated around that base.

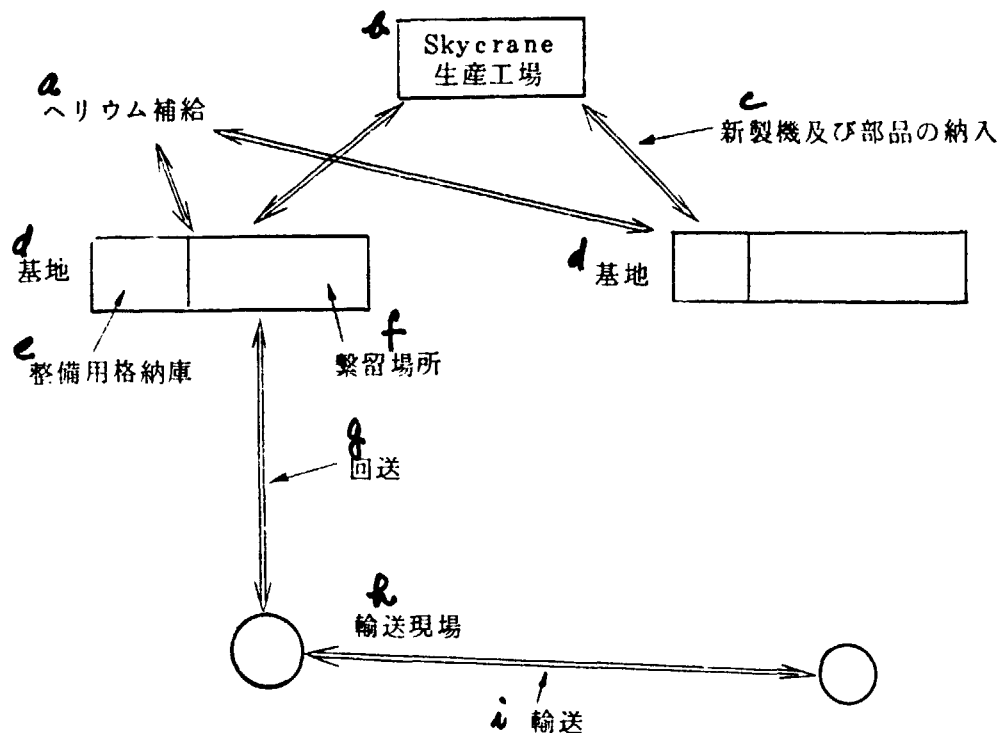

Fig.N-45

Key to Fig. IV-45.

- | | |
|-------------------------------------|-----------------------------------|
| a: Helium Supply | b: Skycrane Manufacturing Factory |
| c: Provision of New Craft and Parts | e: Hangar for Maintenance Work |
| d: Base | f: Mooring Site |
| e: Hangar for Maintenance Work | g: Forwarding |
| f: Mooring Site | h: Transportation Site |
| g: Forwarding | i: Transportation. |
| h: Transportation Site | |

(a) Base for Skycranes.

A base for the Skycrane is built for housing, maintenance, supply of helium and fuel, alternation of crew members and equipment which are used for guiding, and communicating with, the Skycrane in flight. The aircraft are usually maintained in this base and are forwarded to transportation sites at request.

Since the Skycrane support the cargo weight by the helium gas buoyance as well as the rotary wing dynamic lift, the ship body will free without fixing means when it does not carry a load. Therefore, in order to keep the Skycrane on the ground, it is necessary to evacuate the helium gas and to accommodate it in a hangar or to moore it. In case of mooring the Skycrane in a base, it is moored to a mooring tower. In this case, it is necessary to take sufficient precaution to prevent the Skycrane from colliding to the ground due to sudden winds.

The mooring of the Skycrane will be performed as follows:

First, the Skycrane travels to the space above the tower with the navigation lift of its rotary wings. Then, the Skycrane lets a rope out from the bottom of its cockpit and the rope is engaged with the tip of the tower. When the rope is completely connected with the tower, the Skycrane stops its rotors. Thus, the Skycrane is fixed to the tower by means of the helium gas buoyance. In case of accommodating the Skycrane into a hangar in order to take refuge from a typhoon or to undergo a maintenance work, the Skycrane is taken down to the ground by the rope manipulation shown in Fig. IV-47 (4), and then, it is fixed in the hangar with jigs after evacuating the helium gas.

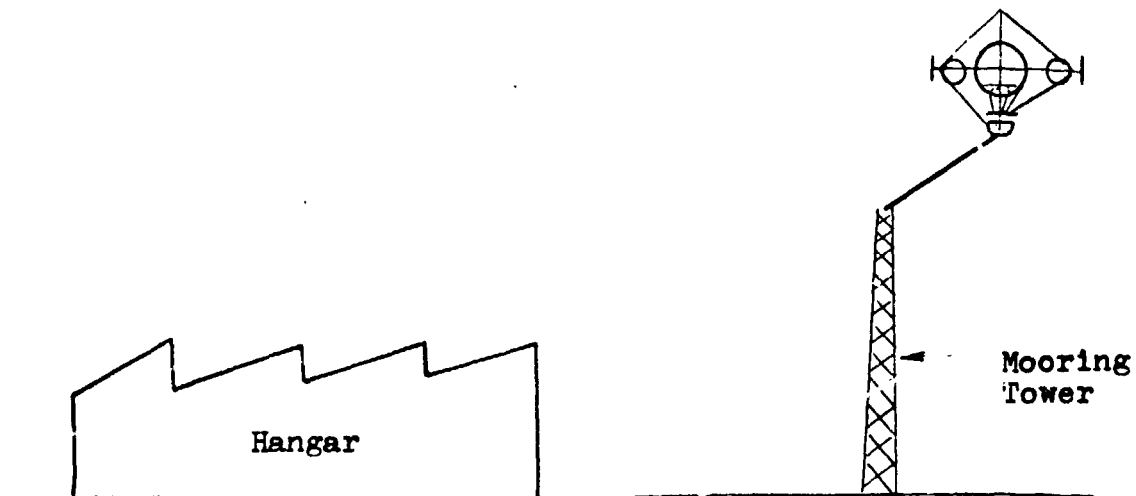

Fig.N - 46

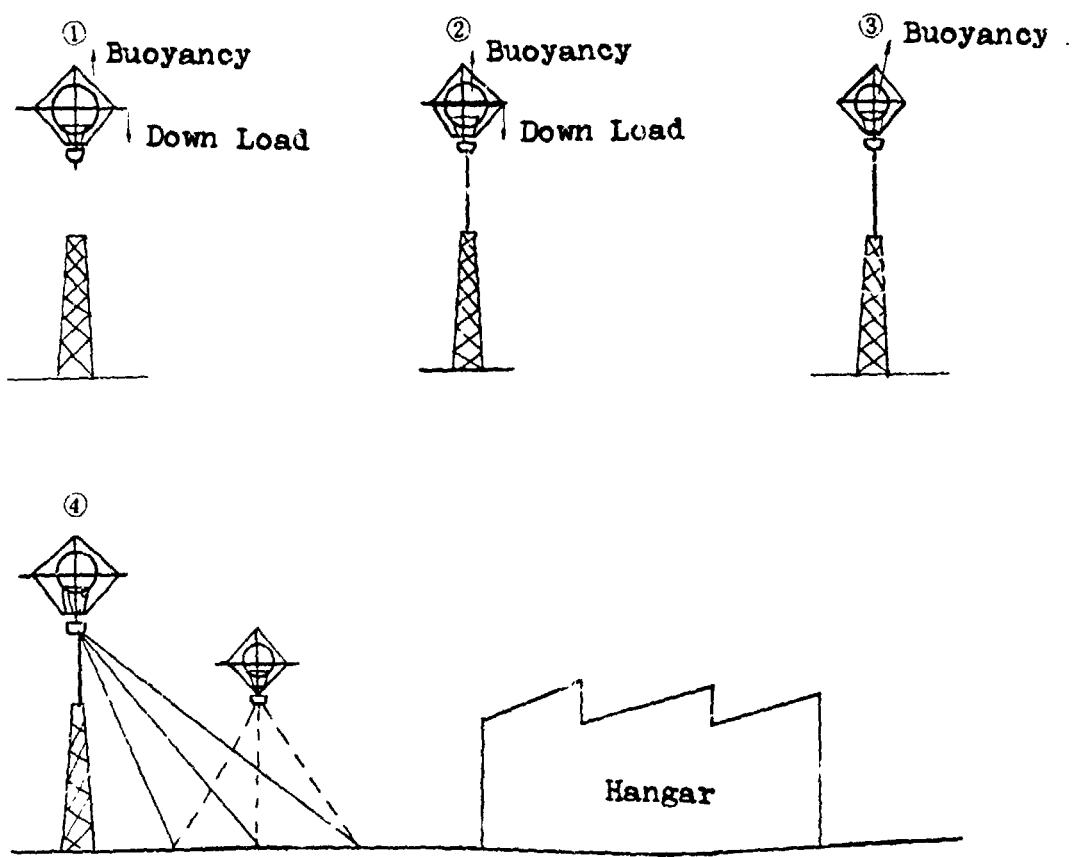

Fig. N-47

When a typhoon approaches, Skycranes take refuge away from the base except the one accommodated in the hangar (which can contain one unit of the Skycrane). When the Skycrane is forwarded from the base to a transportation site, the same manipulations are performed as those shown in Fig. IV-47 but in a reversed order. The supply of the helium and the fuel is performed while the Skycrane is moored to the tower, as well as loading of the crew members. /209

Like other LTA's, the Skycrane is very sensitive to winds due to the low speed. It is necessary, therefore, to determine from which base a Skycrane is forwarded to the site most efficiently considering the wind speed and direction at the base and the site.

(b) Forwarding to Cargo Handling Sites.

When the Skycrane is forwarded to a cargo handling site, it travels by controlling the buoyancy by the navigative lift of its rotary wings without using any ballast. In case that the site is very far, the Skycrane may be transported by ground or sea transportation means to which it is moored.

In forwarding, since the Skycrane travels with no load suspended outside, there may be no serious problem if it travels on an urban area. In forwarding the Skycrane, two crew members are on board. In case of VFR, the Skycrane flies mainly with vision to the cargo handling site. It may also be guided by radar or radio systems.

(c) Cargo Airlifting Work at Cargo Handling Sites.

After the Skycrane is forwarded to a cargo handling site it should be moored to a place which is as much as higher than the other ground as possible in order to prevent it from being thrown to the ground, while waiting for the work. (See Fig. IV-48.)

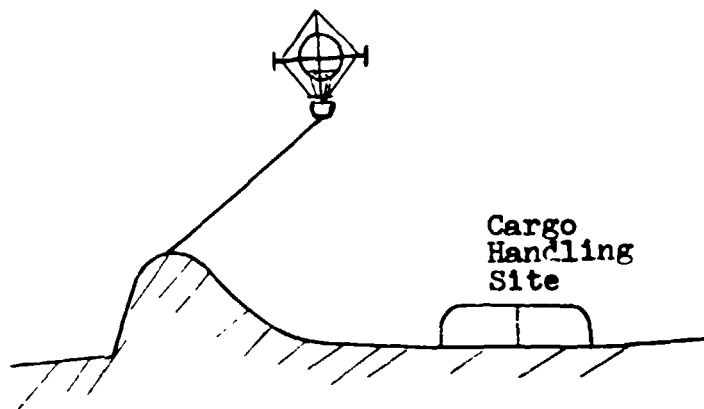

Fig. N - 48

In airlifting a cargo, as shown in Fig. IV-49, the Skycrane hovers above the cargo and lets a rope out from the cockpit by manipulating the winch first, and then, the ship body is fixed to the ground by ground crew members or equipment on the ground. After the cargo is fixed to the cargo suspending rope and the ship body fixing rope is disengaged, both ropes are wound up by winches and the cargo is transported to the destination. As shown in Fig. IV-49-(4), it is possible to use a suspended maneuvering module (SMM) which is specially designed for suspending cargoes.

(d) Cargo Transportation.

When traveling with a cargo being suspended to the ship, the flight should be allowed only under good weather conditions in order to maintain the safety. The travelling route should avoid the resident areas and should be selected to be above rivers and mountains, or, in some cases over the sea.

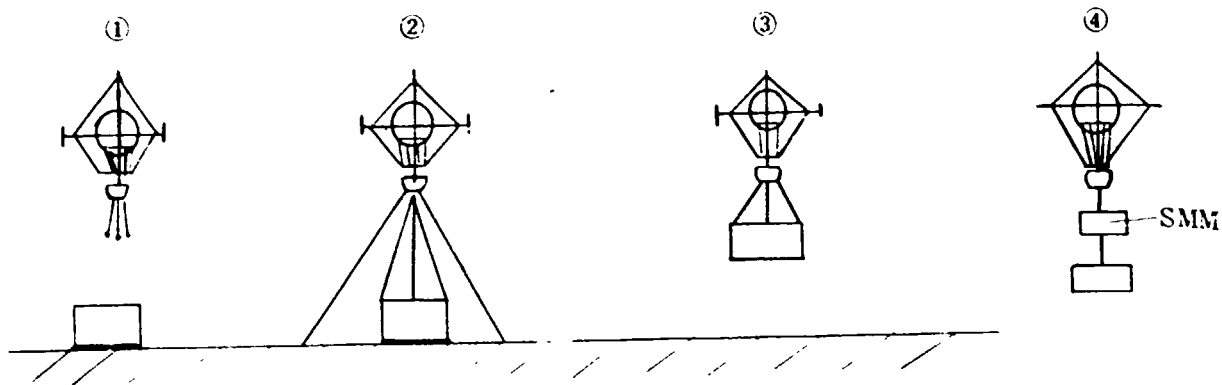

Fig. IV-49

(e) Unloading of Cargo at the Destination.

The cargo is unloaded according to the same manipulations in a reverse order. The Skycrane may install the cargo to an equipment while suspending it, for example a member of a plant equipment.

(f) Refill of Fuel and Helium, and Exchange of Crew Members.

Basically, the refill of helium gas or the exchange of the crew members is performed at the base. If necessary, however, it may be done at the cargo handling site while the Skycrane is moored.

(g) Necessary Space.

In a Skycrane base, one unit of Skycrane needs one tower and an area which is about 16 times as much as the rotary wing area. The necessary space for a hangar is such that it may accommodate two units

of Skycranes. Besides, the base must have a space for a flight control room, facilities for ground crew and flight crew members, etc. At a cargo handling site, an area which is about 16 times as much as the rotary wing area will be necessary for a temporary mooring site. For loading and unloading cargoes, however, only about 4 times as much as the rotary wing area will be sufficient.

IV-4-7. Development Plan.

A feasible plan for developing the Skycrane is shown in Fig. IV-50.

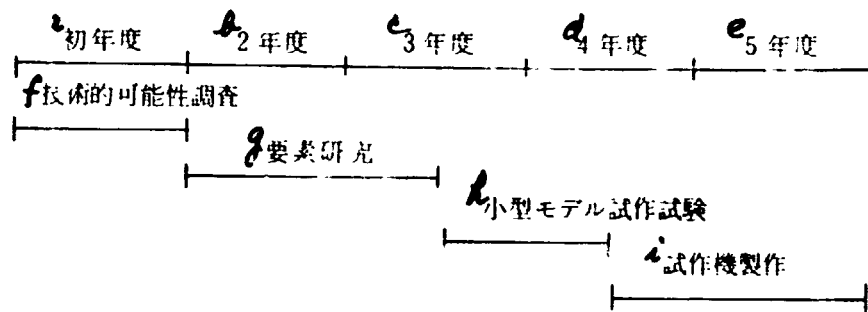

Fig. IV-50

Key to Fig. IV-50.

- | | |
|--|---------------------------|
| a: The First Fiscal Year | b: The Second Fiscal Year |
| c: The Third Fiscal Year | d: The Fourth Fiscal Year |
| e: The Fifth Fiscal Year | |
| f: Survey on Technical Possibilities | |
| g: Studies of Elements | |
| h: Trial-Manufacturing and Tests of Reduced-Scale Models | |
| i: Manufacturing of Test Models | |

(1) Survey of Technical Possibilities (f)

Survey studies must be done in order to determine whether the concept of the Skycrane is technically feasible or not, or whether reasonable price will be realizable or not, in connection of the aimed uses of the Skycrane.

/211

(2) Studies of Elements (g).

Studies of materials of the Skycrane and the functional elements such as rotation control means, and wind tunnel tests and simulation tests for determining the stability and the maneuvering properties.

(3) Trial-Manufacturing and Tests of Reduced-Scale Models (h).

Reduced-scale models will be trial-built in order to make an overall evaluation of performance properties, stability, maneuvering properties, functional characteristics, etc.

(4) Manufacturing of Test Models (i).

Based on the results obtained through the above procedures, test models will be built and a number of tests will be performed in connection with the practical uses of the Skycrane.

IV-4-8. Estimates of Operating Costs of Skycrane.

It is extremely difficult to estimate costs for operation such as the per-hour operating cost based on the actual operation of the conventional airplanes, since the concept of the Skycrane is completely different from that of the airplanes. In this section, every itemized expense will be estimated in order to estimate the operating cost when 5 units of the Skycranes are used for 10 years (which is the life time of the Skycrane).

(a) Assumptions for the Estimation.

(1) Annual Flight Time.

The total annual flight time is 500 hours, 250 hours (50%) of which is used for actually carrying cargoes.

(2) Actual Cargo Handling and Annual Transportation.

If on the average, 65% of the maximum load, 70 tons, is carried actually, the annual transportation is,

$$70 \text{ tons} \times 0.65 \times 50 \text{ km/h} = 570,000 \text{ ton-km.}$$

(3) Others.

When calculating with the 1977 yen value, the fuel unit cost is, 85,000 yen/kl (including the aircraft fuel tax, 13,000 yen per kl).

The interest is estimated to be 7%. In the following calculations, however, 9% will be used for the interest in order for it to include the taxes such as Fixed Asset Tax.

(b) Necessary Expenses for Ten Years.

(1) Depreciation Cost and Interest of Purchase Payment.

Considering ten-year constant depreciation and letting the remaining value of the aircraft by zero, the purchase price of five aircraft is,

$$4.6 \text{ billion yen} \times 5 = 23 \text{ billion yen,}$$

which will be the total depreciation cost.

Thus, the interest is,

$$23 \text{ billion yen} \times (0.09 + 0.09 \times 0.9 + 0.09 \times 0.8 + 0.09 \times 0.1) \\ = \text{about } 11 \text{ billion yen.}$$

(2) Personnel Expenses.

The necessary personnel per one aircraft is:

- 5 on-board crew members (pilots and cargo operators)
- 10 ground assistant members
- 10 maintenance engineers, and
- 5 managing personnel members.

/212

Besides the above personnel, one crew of on-board members and $\frac{1}{2}$ crew of ground members are necessary for the shift personnel. Consequently, 40 persons are necessary for operating one unit of the Skycrane.

The annual personnel expense per one aircraft is,
 $40 \text{ persons} \times 7 \text{ million yen/person} = 280 \text{ million yen, and}$
 14 billion yen for ten years for five aircraft.

(3) Maintenance and Spare Part Costs.

These costs are said to be about 3% of the aircraft price for one year in case of usual airplanes. In an example of non-rigid airship operation, however, they are about 20% of the aircraft price. Thus, the annual costs of maintenance and spare parts of the Skycrane is estimated to be 10% of its price and,
 $4.6 \text{ billion yen} \times 0.1 \times 5 \text{ aircraft} \times 10 \text{ years} =$
 23 billion yen.

(4) Aircraft Insurance.

The annual insurance cost is about 0.5% of the aircraft price for airplanes in most airlines. Considering examples of non-rigid airship operations (15-20%), however, it is estimated to be 10% and 23 billion yen.

(5) Fuel and Lubricant Oil.

Letting the fuel unit consumption be 2,500 l/h, the fuel and lubricant oil cost is,
 $2.5 \text{ kl/h} \times 500 \text{ h/year} \times 5 \text{ aircraft} \times 10 \text{ years} \times 1.1^* \times 85,000 \text{ yen/kl} = 6 \text{ billion yen,}$
 for ten years. Note: * 1.1 is the coefficient introduced for including the lubricant oil cost in the fuel cost.

(6) Depreciation Cost and Purchase Payment Interest of Ground Facilities.

Required Ground Facilities:

Mooring Bases:	5 places
Ground Area:	$200\text{m} \times 200\text{m} = 40,000 \text{ m}^2$
Mooring Equipment:	one set
Maintenance Base:	1 place (adjacent to the mooring bases)
Ground Area:	$150\text{m} \times 150\text{m} = \text{ca. } 20,000 \text{ m}^2$
Hangar:	$120\text{m} \times 120\text{m} \times 150\text{m} \text{ (height)}$
Purchase Expenses:	
Land Area:	$40,000\text{m}^2 \times \frac{5}{2} + 20,000\text{m}^2$ $= 220,000 \text{ m}^2$
Unit Land Price:	$25,000 \text{ yen/m}^2$
Total Land Cost:	$220,000\text{m}^2 \times 25 \text{ thousand yen/m}^2$ $= 5.5 \text{ billion yen}$

Mooring Equipment: five sets (100 million yen per one place)
 500 million yen (in Total) /213
 Hangar: 120m x 120m x 170,000 yen
 x 1.6* = 4 billion yen

(Note:* It is said that construction cost of a hangar is usually about 170,000 yen per m². Since the hangar for the Skycrane is much higher than usual hangars, the cost is estimated 1.6 times higher.)

Depreciation and Depreciation Cost:

The land is not depreciated.
 20-year constant depreciation is used for the mooring equipment, while 34-year constant depreciation is used for hangars according to the provision of the law.

Depreciation Cost of

Mooring Equipment: 0.5 billion yen x (1/20)
 x 10 years = 250 million yen
 Hangar: 4 billion yen x (1/34) x 10
 years = 1.25 billion yen
 Total Depreciation Cost: 1.5 billion yen

Interest:

Land: 5.5 billion yen x 0.09 x 10 = 5 billion yen
 Mooring Equipment: 500 million yen x (0.09 + 0.09x0.95 + 0.09x0.90 + ... + 0.09x0.55)
 = 360 million yen.
 Hangars: 4 billion yen x (0.09 + 0.09x0.97 + 0.09x0.94 + ... + 0.09x0.74)
 = 3.14 billion yen ca.
 Total of Interest: 8.5 billion yen

(7) General Management Expenses.

The general management expenses is assumed to be 5% of the sum of the expenses listed hereinabove and be 6 billion yen.

(8) Total Expenses for Ten Years.

Depreciation of Aircraft:	23 billion yen
Interest of Aircraft Purchase Payment:	11
Personnel Expenses:	14
Maintenance and Spare Part Expenses:	23
Aircraft Insurance:	23
Fuel Cost:	6
Depreciation Costs of Ground Facilities:	1.5
Interest to Purchase Payment of Ground Facilities:	8.5
General Management Expenses:	6.0

Total:	116 billion yen
Operating Cost per one Aircraft for ten years:	23.2 billion yen
Unit Operating Cost per 1-ton cargo per km:	$23.2 / 10 \text{ years} / 570,000 = 4,100 \text{ yen}$ /214
Average Unit Operating Cost: (with average transportation distance being 50 km and with the annual total flight time being 500 hours)	$4,100 \times 50 = 205 \text{ thousand yen}$

According to the above result, the operating cost per 1-ton cargo per 50-km transportation distance varies with the annual total flight time as follows:

Annual Total Flight Time	Operating Cost per one ton and per 50 km
500 hours	ca. 200,000 yen
800 hours	ca. 130,000 yen
1,000 hours	ca. 100,000 yen

(c) Estimates Made by Asahi Helicopter Company.

The Asahi Helicopter Company was asked to critically evaluate the estimates described above and to make similar estimates when the conventional helicopters are used in the same operations under the same conditions.

The result of this evaluation is summarized as follows:

	Initial Estimates	Estimates by Asahi Helicopter Company
Depreciation Cost of Aircraft:	23 billion yen	23 billion yen
Interest of Aircraft Purchase Payment:	11	12.1
Personnel Expenses:	14	18.4
Maintenance and Spare Part Expenses:	23	45.4
Aircraft Insurance:	23	28
Fuel Cost:	6	29.5
Depreciation Costs of Ground Facilities:	1.5	4.5
Interest to Purchase Payment of Ground Facilities:	8.5	8.5
General Management Expenses:	6	8.5
Others:	---	1.5
<hr/>		
Total	116 billion yen	179.4 billion yen.

The explanations given by the Asahi Helicopter Company to the above estimates are summarized as follows:

(1) Interest of Aircraft Purchase Payment:

The initial estimate, 7%, is too low and it will amount

at least at least to 9%. Correspondingly, these estimates could be increased by about 1.1 billion yen for ten years.

(2) Personnel Expenses:

The estimate, 7 million yen per year per person, is adequate, although the average annual increase of the personnel expenses is estimated to be 11% (average among 17 representative enterprises).

(3) Maintenance and Spare Part Expenses:

/215

The initial estimate, 10% of the aircraft price, is an under-estimation. It should be 20% for a year. For example, the maintenance and spare part expenses are 30% of the aircraft price for the aircraft body and 25 to 30% for the engines, in a case of a helicopter made in the Soviet Union. In addition, an overhaul must be performed once every 1,000 to 1,500 hours of flight, and once every three years if the total annual flight time is 400 hours.

(4) Aircraft Insurance:

The estimate should be slightly higher than the initial estimate, 10% of the aircraft price. In case of the conventionally used small-size non-rigid airships, the insurance is 15 to 20% of the aircraft price. For example, if a new helicopter transportation company starts its operation,

9% (for helicopters with reciprocal engines), and
3% (for helicopters with jet engines)
of the aircraft prices are spent for the insurance. In addition, insurance for the damage to the third person is necessary. According to the estimate made by an insurance company, this kind of insurance is about 1,200 thousand yen per year for an ultra-large-size helicopter (with the aircraft price of 10 billion yen). It should be noted that this amount is only an estimate at present.

(5) Fuel Consumption:

According to the initial estimation, the fuel consumption has been estimated to be 2,500 l per one hour. The Asahi Helicopter Company, however, estimates it to be 3,270 l/hour.

Furthermore, it is estimated that the fuel unit cost at the sites where the aircraft are used is 107 thousand yen per kl, as being shown in the following:

Average Fuel Purchase Price:	7,200 yen/kl
Tax:	1,300 yen/kl

Cost of Drum-Can Transportation to the Site
Where the aircraft are used:

plus 30%

Total:

10,700 yen/kl

The estimate by the Asahi Helicopter Co. is consequently 29.5 billion yen and is much higher than the initial estimate, 6 billion yen.

(6) Ground Facilities:

According to the initial estimation, the periods of depreciation are 20 years and 34 years, for mooring equipment and hangars, respectively. The Asahi Helicopter Company used 10-year depreciation which has been adopted for the aircraft. Consequently, the estimate by Asahi Helicopter Company is 4.5 billion yen and is three times as much as the initial estimate, 1.5 billion yen.

The estimates by the Asahi Helicopter Company have been explained schematically as above.

However, the estimates by the Asahi Helicopter Company have been made based on the operation of the conventional helicopters and there remain several questions pertaining to whether it is appropriate or not to estimate the costs of the aircraft operation based on the helicopters since their payloads are one order smaller than the Skycranes which have been reported here.

Nevertheless, the author feels that the estimates by the Asahi Helicopter Company are worth while sharing a section in this report for a reference.

Furthermore, performance properties and economic efficiency are compared among the rota-ship, the Skycrane and large-size helicopter in Table IV-18.

Table IV-18.

/216

Aircraft	Rental Charge (per hour)	Payload	Flight Time	Distance of Cruise	Speed
Skycrane	6 million yen	70 tons	3 hours	150 km	50km/h
Rota-Ship	4.24 m. yen	30 tons	3 hours	330 km	100 km/h
KV-107	0.74 m. yen	3.4 tons	3 hours	700 km	236 km/h

The Megalifter aircraft is a hybrid of an airship and an airplane. It is being planned by the National Aeronautics and Space Administration in the U.S.A. NASA's goal is a 180-ton (400,000-lb) payload aircraft which can carry the payload for 16,000 km (10,000 miles). An aircraft body as shown in Fig. IV-51 has been proposed. (Cf. Reference 1) The specifications of this aircraft are given in Table IV-19. In this section, simple calculations on its performance properties will be described.

IV-5-1. Resistance.

When the resistance is divided into shape resistance C_{Do} and induced resistance C_{Di} , the former consists of several components, i.e., wing resistance C_{Dw} , tail resistance C_{DT} , fuselage resistance C_{DB} , engine resistance C_{DE} and the interference resistance resulting from the interaction of these resistance components, written as:

$$\begin{aligned} C_{Do} &= C_{Dw} + C_{DT} + C_{DB} + C_{DE} + C_{DM} \\ &= 0.0043 + 0.0041 + 0.0149 + 0.0032 + 0.0015 = 0.028 \end{aligned} \quad (1)$$

Induced resistance is written using the efficient aspect ratio AR_e as,

$$\begin{aligned} C_{Di} &= C_L^2 / \pi AR_e \\ &= 0.034 C_L^2. \end{aligned} \quad (2)$$

When defining the efficient aspect ratio, the wing length is assumed to be extended into the fuselage. The efficient aspect ratio is the aspect ratio multiplied by the efficiency e , considering a perturbation from the elliptic shape of the wings. If this efficiency e is 0.8,

$$AR_e = AR \times e = 11.7 \times 0.8 = 9.4. \quad (3)$$

The reason for the assumption that the wing is almost elliptic regarding it as being extended into the fuselage, (thus setting $e = 0.8$) is as follows:

Fig. IV-52 shows a lift distribution along the wing width direction in terms of the product $C_l \times C$ of the secondary lift coefficient C_e and the wing chord C . This distribution can be seen as a cyclic distribution along the wing width. In the figure, (a) shows the result when calculated with the assumption that the fuselage cross-section is circular and

there is no warp, while (b) shows the result when assuming that the fuselage cross-section is rectangular and the wing shape is as same as the NACA-4418 with some warps.

As seen from this figure, with the appropriate fuselage shape and the main wing attachment angle, the cyclic distribution may approach a desired distribution, i.e., an elliptic-shape distribution, regarding the fuselage as a part of the wing. It is for this reason that the assumption that the distribution is almost elliptic and the assignment $c = 0.8$ are reasonable. Thus, AR has been selected to be 9.4.

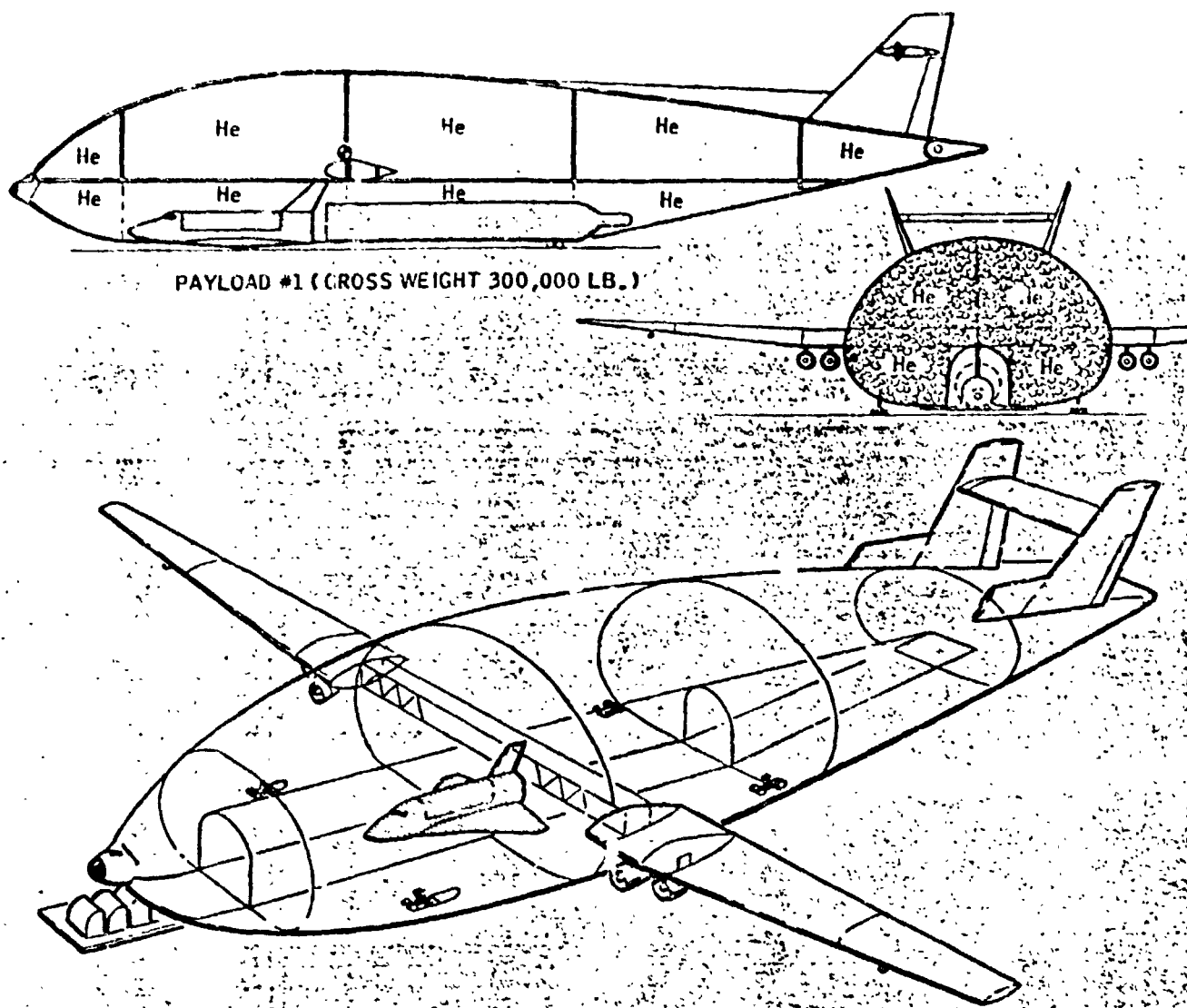

Fig. IV-51. Megalifter

ORIGINAL PAGE IS
OF POOR QUALITY

Table IV-19. Specifications of Megalifter.

Specifications	
Fuselage Length l	198 m
Fuselage Width d	54 m
Fuselage Height h	35 m
Fuselage Cross-section Area p	1,485 m ²
Efficient Fineness Ratio $i/\sqrt{(4p/\pi)}$	4.55
Main Wing Width b	162 m
Main Wing Thickness Ratio t/c	0.226
Main Wing Area S	2,240 m ²
Aspect Ratio AR	11.72
Gross Weight W_G	510 tons
Dead Weight W_E	329 tons
Fuel Weight W_f plus payload W_p	181 tons
Engines TF39-GE-1	100 tons x 4

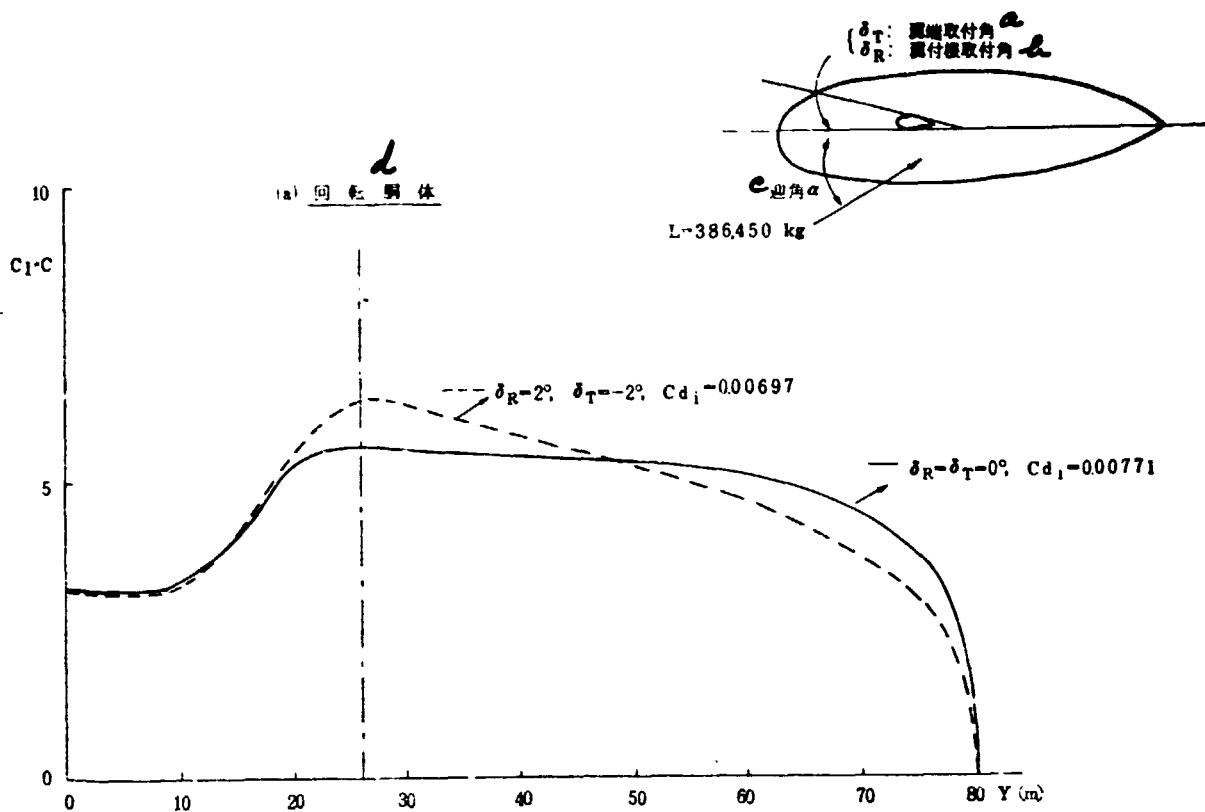

Fig. IV-52. Lift Distribution (1)

Key to Fig. IV-52 (1)

a: Wing Tip Angle
c: Elevation Angle

b: Wing Root Angle
d: Fuselage of Revolution Body

ORIGINAL PAGE IS
OF POOR QUALITY

C-4

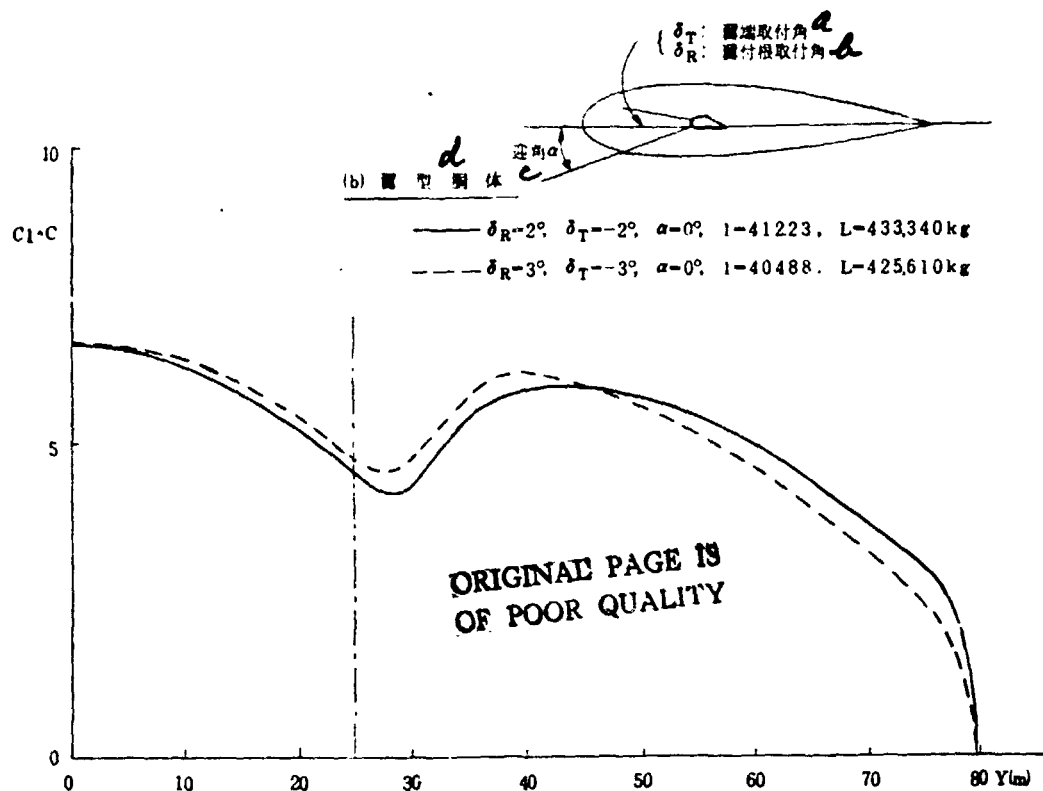

Fig. IV-52. Lift Distribution (2)

Key to Fig. IV-52 (2).

a: Wing Tip Angle
c: Elevation Angle

b: Wing Root Angle
d: Fuselage of Wing Shape

IV-5-2. Lift Resistance Characteristics.

Using the resistance values determined in the previous section, the wing lift resistance characteristics including the fuselage, C_L/C_D and $\sqrt{C_L/C_D}$ have been calculated and the results are shown in Fig. IV-53. In Fig. IV-53, the corresponding characteristics of a cargo transportation airplane, Kawasaki C-1, are shown by broken curves. Those characteristic values of the Megalifter are both higher than those of the C-1 when C_L is high. A high C_L/C_D is advantageous in flight distance for propeller aircraft, while a high $\sqrt{C_L/C_D}$ is advantageous for jet planes.

IV-5-3. Performance Properties.

The required thrust and the useful thrust are plotted for the Megalifter in Fig. IV-54. The conditions for the calculation are: The flight altitude is 5,500 m (18,000 feet) and the gas buoyancy supports $B = 124$ tons out of the gross weight $W_G = 510$ tons, while the remaining $L = W_G - B = 386$ tons is supported by the dynamic lift of the wing. If all the payload is used for carrying the fuel, $W_f = 181$ tons, and if the cruising speed is constant and specific fuel cost is constant, $(\eta_j/b_j) / \sqrt{\sigma} = 4.5$ (by analogy from the case of the C-5A). The maximum distance of cruise is,

$$R = 15.55 \frac{\eta_j}{b_j} \frac{\sqrt{C_L}}{C_D} \frac{1}{\sqrt{\sigma}} \sqrt{\frac{L}{S}} \left(1 - \sqrt{\left(1 - \frac{W_f}{L}\right)} \right) = 4,850 \text{ nm}, \quad (4)$$

where the cruising speed is $U = 190$ knots and $C_L = 0.53$.

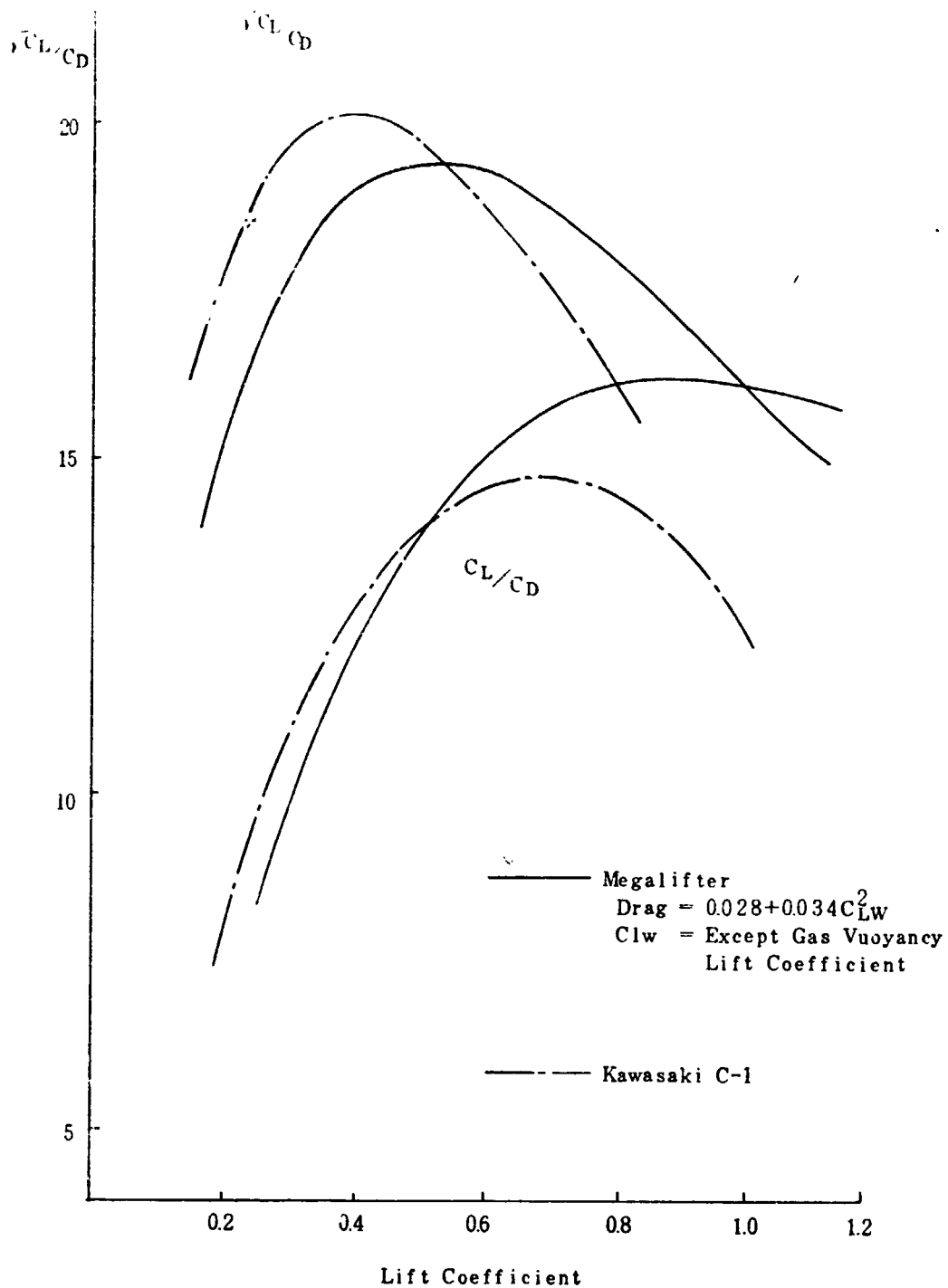

Fig. IV-53. Lift Resistance Characteristics.

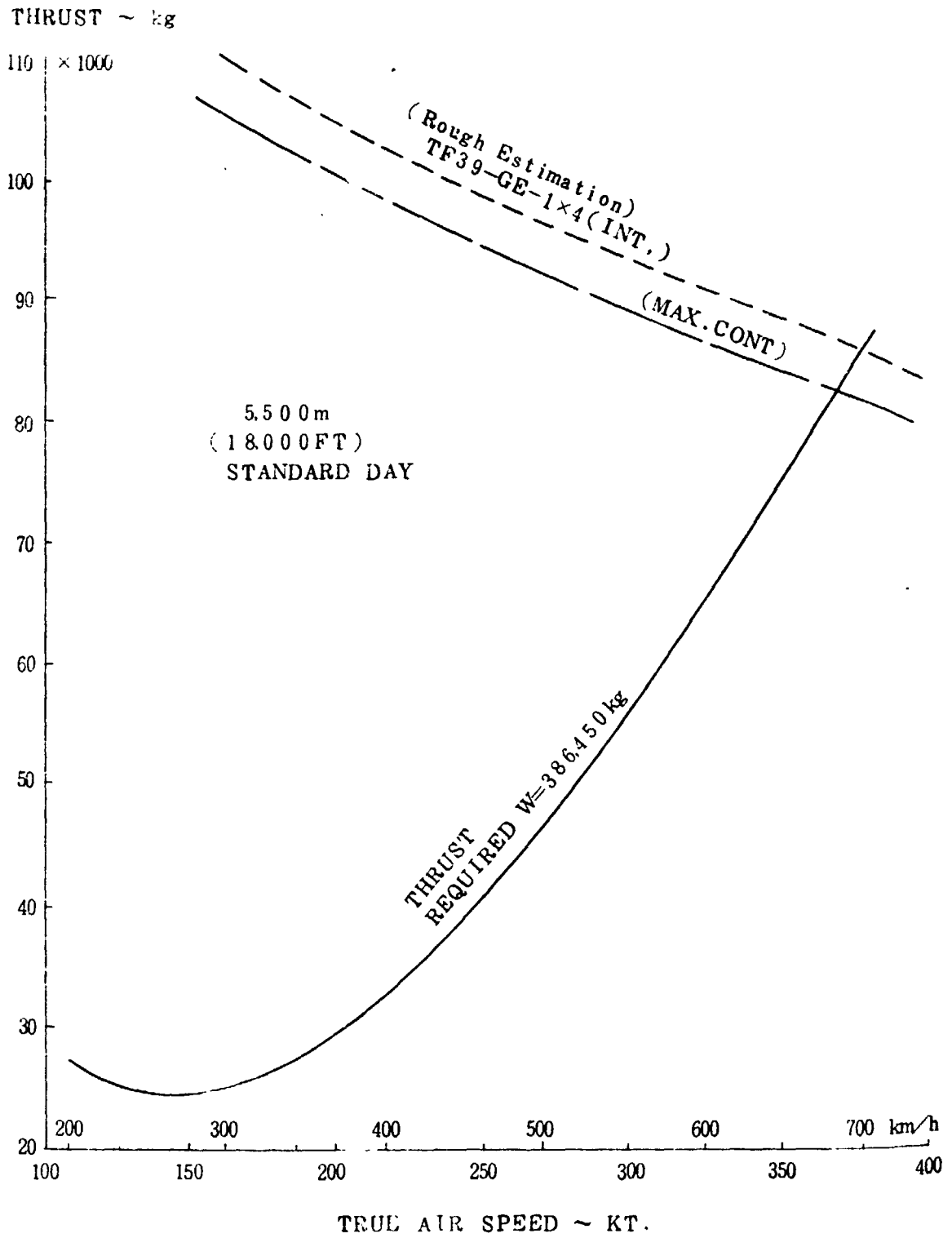

Fig. IV-54. Required Thrust and Usable Thrust

In this calculation, it is assumed that the Megalifter starts to fly at the altitude of 5,500 m. However, since the buoyance, $b = 217$ tons, can be utilized at sea level, the maximum distance of cruise in an actual flight will be more than that in the above calculation. /223

For the calculations of performance properties, the following three cases have been selected and are supposed to represent three extreme cases. In the first two cases (i) and (ii), the gross weight is the same. In case (ii), however, the buoyance is $B = 217$ tons and is greater than that of case (i), while the support by the dynamic lift, $L = W_G - B = 293$ tons, in case (ii) is less than that of case (i). In the third case (iii), the fuel weight W_F is increased to 274 tons, and correspondingly, the gross weight W_G is increased to 603 tons which is supported by greater dynamic lift $L = 386$ tons and greater buoyance $B = 217$ tons. Table IV-20 shows the results of performance property calculation of these three cases (i) to (iii) with parameters used for calculation in each case. In addition, these results are summarized in Fig. IV-55 which shows the relationship between the cruising distance and the payload. In the reference literature 1, it is stated that the maximum cruising distance is 10,000 miles. Probably this result corresponds to that of the calculation using the assumptions in the above case (iii). Since the parameters in cases (i) to (iii) are extreme ones for the calculation purposes, the actual maximum cruising distance will be between those of cases (i) and (iii). More precise calculations are the goals of future studies.

Table IV-20. Parameters for and Computed Result of Performance Property Calculation.

Cases	(i)	(ii)	(iii)
Gross Weight W_G	510 tons	510 tons	603 tons
Dead Weight W_E	329 tons	329 tons	329 tons
Fuel Weight W_F plus payload W_P	181 tons	181 tons	274 tons
Buoyance B	124 tons	217 tons	217 tons
Dynamic Lift L	386 tons	293 tons	386 tons
Cruising Speed	190 knots	163 knots	190 knots
Lift Coefficient	0.53	0.53	0.53
Maximum Cruising Distance with W_P = 0	4,850 m	5,940 m	8,230 m

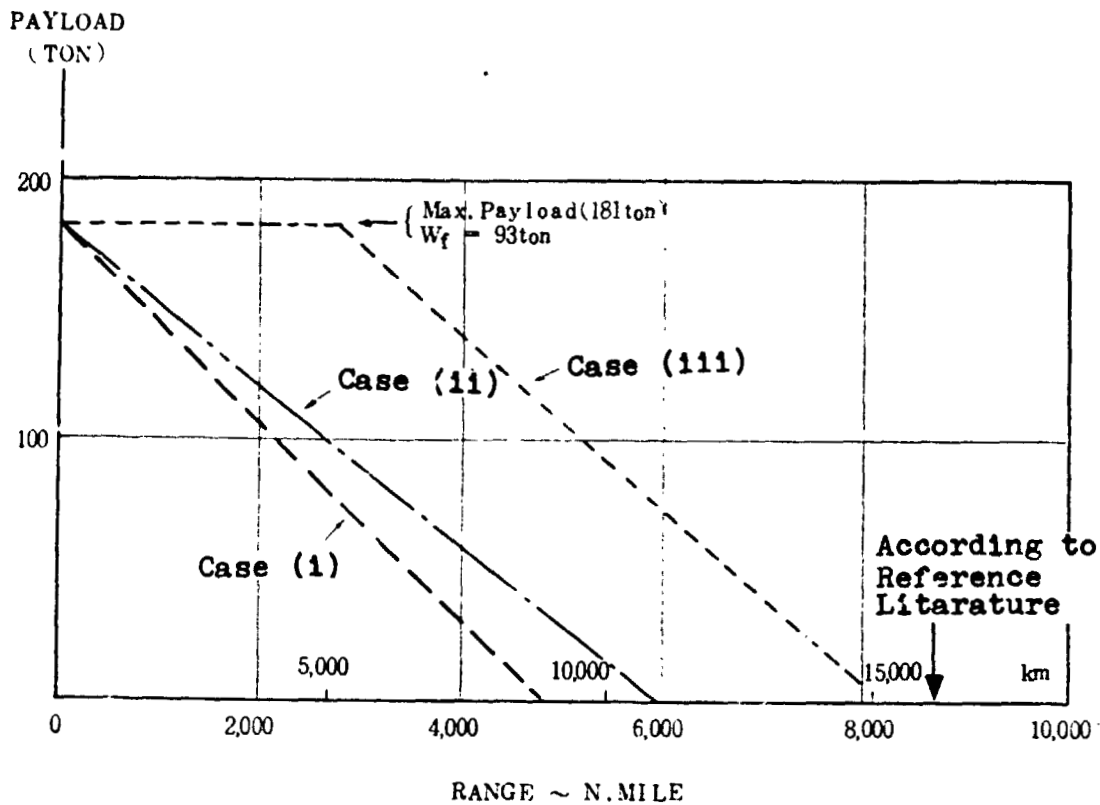

Fig. IV-55. Payload and Distance of Cruise

Reference.

1. Anon., "Hybrid heavy lift vehicle under study," Aviation Week and Space Technology, July 29, 1974.

IV-6. Technological Studies of Automatic Operating Devices of Suspended Gondolas.

The concept of the Rescue LTA will be described in this section. The Rescue LTA is a combination of a conventional type LTA and a suspended maneuvering module (referred as SMM hereinbelow) and is designed for use in rescue works.

IV-6-1. Suspended Maneuvering Module (SMM).

The SMM has the construction shown in Fig. IV-56. When it is connected with an LTA, it is a gondola which is suspended from the LTA by a cable and which accommodates rescue or fire-fighting members as well as victims. The SMM can make a self-determined motion independent of the LTA which suspends it, and thus, approaches the fire or the places

where victims are located, owing to the winding control of the suspending cable, the thrust vector control by vectorable nozzles are provided on both sides of the SMM and are rotated by means of air motors operated by the bleed air of the engine, so that the vector of the thrust may be selected freely within the X-Y plane. The function of these nozzles enable the SMM to move to or stop at any place in the X-Y plane. (See Figs. IV-59 and 60.)

/225

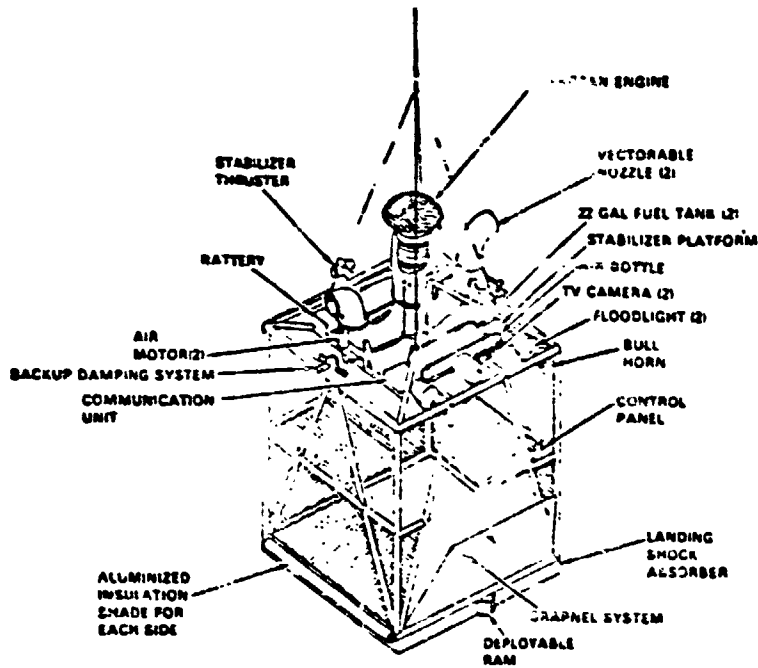

ORIGINAL PAGE IS OF POOR QUALITY

Fig. N - 5 6

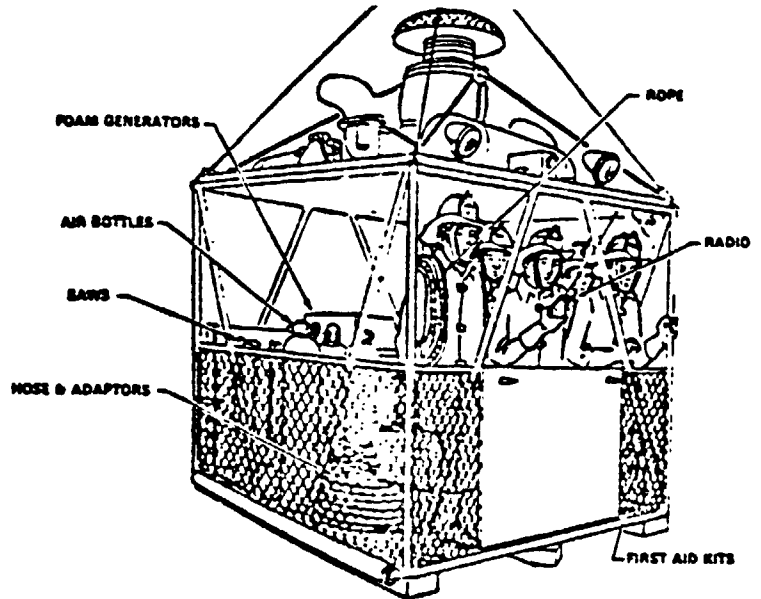

ORIGINAL PAGE IS OF POOR QUALITY

Fig. N - 5 7

A stabilizer thruster provided on the SMM controls the thrust by an on-off control and prevents the gondola from rotating along the Z-axis. (It can also be used to rotate the gondola.) (See Fig. IV-59)

When the engine stops accidentally, a cold gas system prevents the gondola from swinging. (See Fig. IV-61.)

ORIGINAL PAGE IS
OF POOR QUALITY

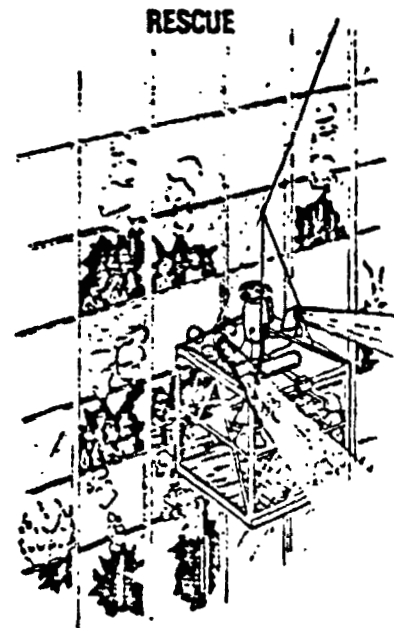

Fig. N - 58

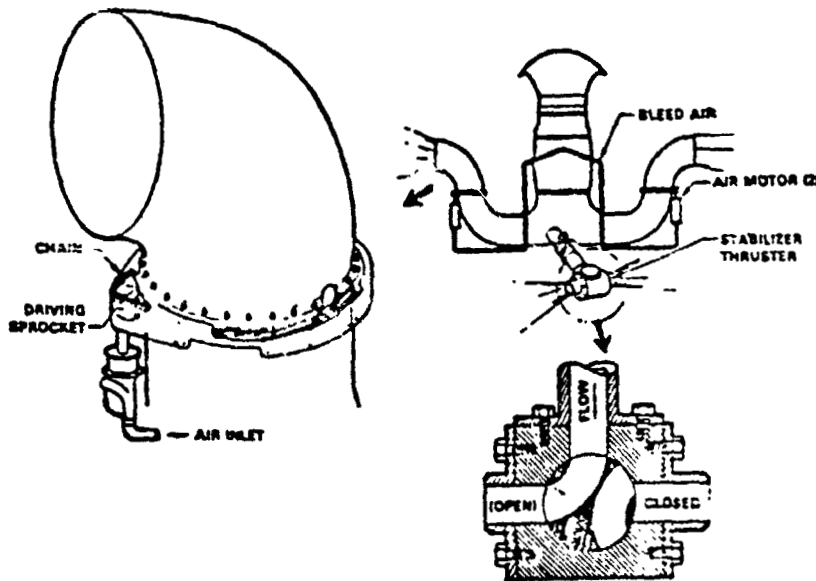
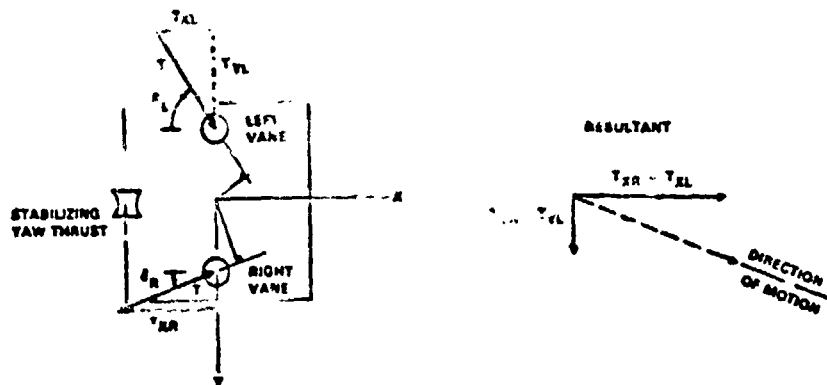

Fig. N - 59



$\delta_L =$ Angle of Left Vane

$\delta_R =$ Angle of Right Vane

Yaw Thrust = $\frac{3}{4} T (\cos \delta_L - \cos \delta_R)$

Fig. N - 6 0

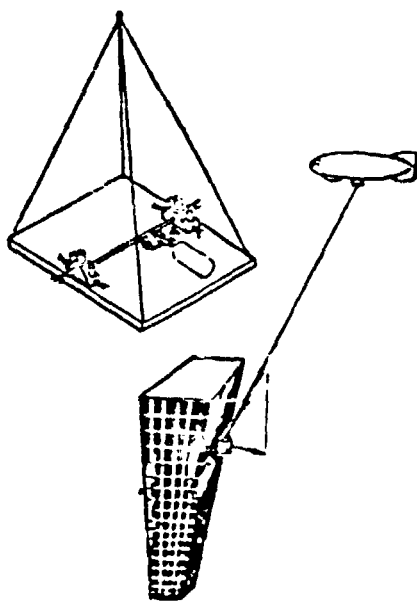

Fig. N - 6 1

ORIGINAL PAGE IS
OF POOR QUALITY

IV-6-2. Study of Concept of Suspended Maneuvering System with SMM
Suspended on LTA.

/228

For the study of the concept of suspended maneuvering system which has a SMM suspended by an LTA and is used for rescue and fire-fighting works, the following specifications have been selected:

Specification

- | | |
|---|---|
| (1) Payload: Mother Ship: | 8 tons (of water) |
| Gondola: | 1 ton (rescued persons etc.) |
| (Both kinds of loads are not carried at the same time.) | |
| (2) Mother Ship Speed: | 15 knots |
| (3) Mother Ship Endurance
Flight Time: | 12 hours |
| (4) Work Period: | 1 hour |
| (5) Flight Crew: | 2 persons in Mothership
2 persons in Gondola |

As a system which satisfies the above specifications, a suspended maneuvering system is designed as follows:

Specifications of Mother Ship

Type:	Non-Rigid Ship
Total Length:	120 m
Diameter:	24 m
Engine: Type:	Gasoline Engine
Horse Power:	1,300 HP
SFC:	0.2 kg/HP/h
Payload: Water:	8,000 kg
Gondola:	872 kg
Dead Weight:	19,800 kg
Buoyance at Sea Level:	30,700 kg
(Gas Volume:	3.1 x 10 ⁴ m ³)

Note: When discharging the water, the ship is controlled by abandoning the helium gas.

Gondola Weight

Payload:	1,000	kg (including crew: 75 kg x 2)
Engine:	145	
Fuel	168	
Structure	293	
Cable:	116	
Communication/Electronics Devices:	45	
Total:	1,722	kg

Engine on Gondola

William Research Engine	WR 19-9
Bypass Ratio:	5:1
S.F.C.:	0.53 lb/HP/1bf
Thrust:	249 kg
Gondola Acceleration:	0.1 g
Gondola Load Factor with Winds:	13.2 kg/m ²

/229

Estimates of Price

Mother Ship LTA:	2,000 to 2,500 million yen
Gondola (SMM):	800 to 1,000 million yen

CONTENTS

V-1. The Problem of Helium Supply and Demand..... 293 (231)
 Introduction..... 293 (231)
 V-1-1. Historical Background of Helium..... 295 (232)
 V-1-2. Uses of Helium..... 298 (234)
 V-1-3. Helium Resources..... 299 (235)
 V-1-4. United States' Plan for Preservation..... 301 (236)
 V-1-5. Prospects for Future Helium Supply and Demand.... 302 (237)
 V-2. Study of Laws Concerning Suspended Transport..... 303 (238)

V-1. The Problem of Supply and Demand for Helium.

Introduction.

The decline of the airships began with the explosion accident of the Hindenburg on May 6, 1937. It has become very common to use helium gas for buoyant gas instead of hydrogen gas. As shown in Fig. V-1, besides helium and hydrogen, kinds of gas which can be used as buoyant gas include methane, natural gas, hot air, vapor and ammonia.

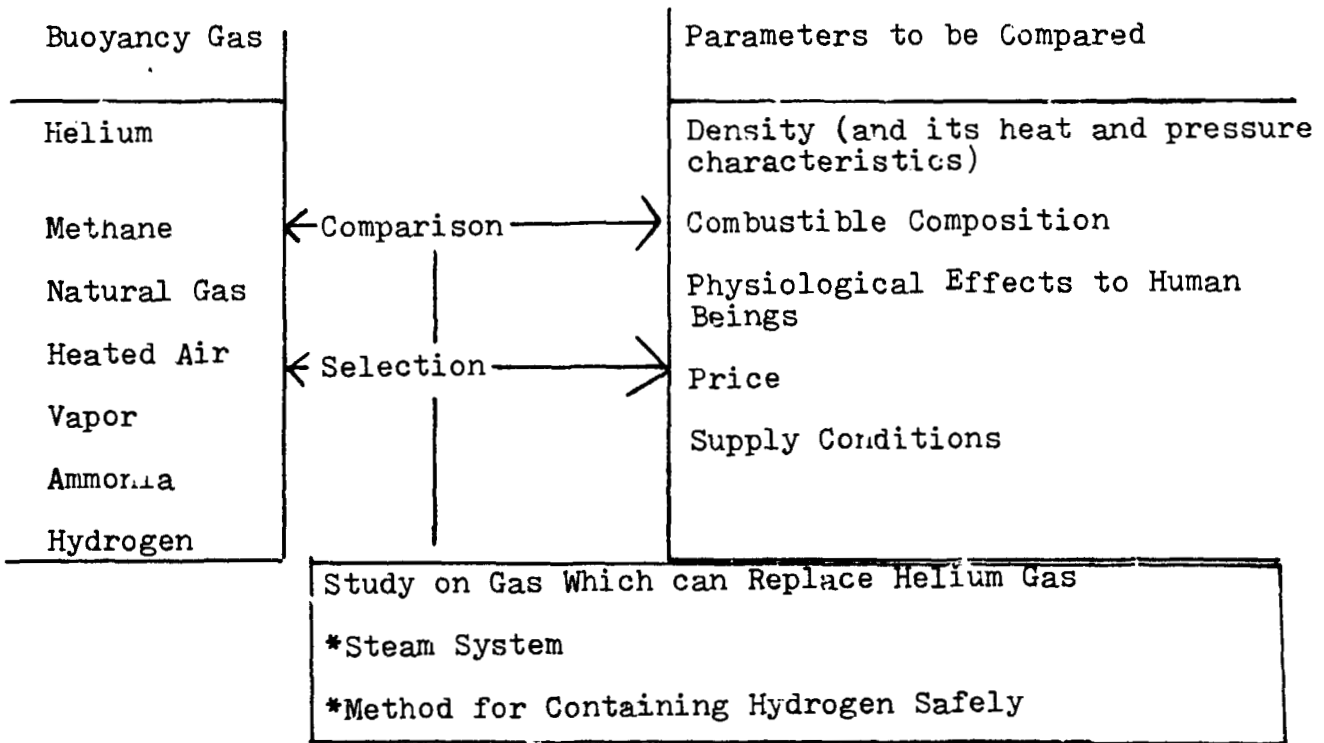

Fig. V-1. Selection of Buoyant Gas.

Table V-1. Buoyant Gas Characteristics.

Buoyant Gas	Combustible Composition (Volume Ratio to Air)		Density (ISA SL) kg/m ³	Buoyancy (ISA SL) kg/10 ³ m ³	Price	
	Lower Limit	Upper Limit			1975 U.S. \$ 10 ³ m ³	Unit Price per Buoyancy ¢/kg
Hydrogen H ₂	4.2	74.2	0.085	<u>1.140</u>	144.8	12.7
Helium He	<u>0</u>	<u>0</u>	0.169	1.056	1687.8	159.7
100° C Vapor	<u>0</u>	<u>0</u>	0.537	0.629	<u>3.5</u>	6.
Methane NH ₄	5.0	15.0	0.678	0.547	70.6	13.0
Ammonia NH ₃	16.0	27.0	0.720	0.505	194.2	37.9
Natural Gas (Average)	4.5	14.5	0.300	0.425	45.9	10.6
Air 120° C	0	0	0.897	0.327	75.9	23.7
100° C	0	0	0.946	0.279	60.0	22.0
15° C	0	0	1.225	0	0	---

However, when safety, supply conditions and easiness of system design are taken into account, it is concluded that helium gas is the most appropriate, at least at present. For reference, alternative buoyant gases are shown in Table V-1. Fig. V-2 shows the temperature characteristics of the buoyancy of various kinds of gas.

/232

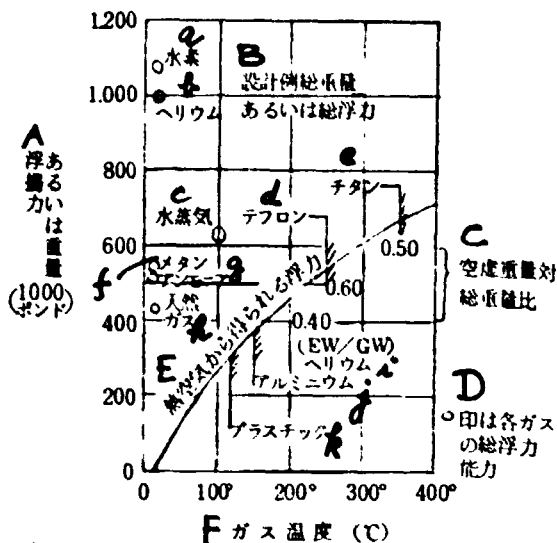

Fig. V-2. Change in Buoyancy in Response to Temperature Change. (453 x 10³ m³ Airship)

Key to Fig. V-2.

- A: Buoyancy or Weight (1000 lb)
 - B: Total Weight of Designed Airship or Total Buoyancy
 - C: Ratio of Dead Weight to Gross Weight
 - D: Total buoyance ability of each gas is plotted by o.
 - E: Buoyancy Obtained by Hot Air
 - F: Gas Temperature (°C)
- | | |
|-------------|----------------|
| a: hydrogen | b: helium |
| c: vapor | d: tephron |
| e: titanium | f: methane |
| g: ammonia | h: natural gas |
| i: helium | j: aluminum |
| k: plastics | |

V-1-1. History Background of Helium.

The history of helium production has a peculiar background. Namely, its development has not been supported by private sectors but has been highly dependent on governmental policies. In the following, historical events surrounding the uses of helium will be described, starting with the discovery of helium.

The boiling point of helium is -269°C , which is four degrees of absolute temperature. At this temperature, most other materials are in a solid or liquid form. This peculiar property has induced the recent use of large amounts of helium for pressure feeding the rocket propellant, i.e., liquefied oxygen and hydrogen.

Helium was first discovered in the spectrum of the sun beam in 1868, In 1881, helium was also observed in the eruption blaze of Mt. Vesuvius in Italy. Two Englishmen, Lord Rayleigh and Sir William Ramsay succeeded in extracting helium out of ground ores in 1895. Three years later, it was proved that helium can be separated from the atmosphere. The earth's atmosphere contains 0.0005-% volume percentage of helium. In principle, extraction of helium from the atmosphere can be done by repeating adiabatical expansion and by obtaining ultra-low temperature. This technique, however, is very difficult, and had been practically impossible until Linde invented an efficient method for extracting helium in the beginning of the 20th century. The principle of this technique is basically the same as that of fractional distillation, which is a method for separating composite liquid. According to this method, composites of different boiling points are extracted at their own boiling points in a process of liquefying the air. The boiling points of nitrogen and oxygen are -196°C and -184°C . After these gases are liquefied, composite gas of neon and helium remains in a distillation tower, as a main component. Then this composite gas is absorbed to active carbon and is distilled at each boiling point. (The boiling point of neon is -250°C .)

Mass consumption of helium started in the U.S. and England around World War I, when helium gas was used for the buoyant gas of air-raid defense balloons in England. A survey for helium resource was done, sponsored by the British Ministry of the Navy. This survey was performed throughout the British Commonwealth, and as a result, helium resource was discovered in Canada. In 1918, a small-scale plant was built at Calgary in the State of Alberta and the excavation was started. (60,000 ft^3 was excavated by this plant which was closed in 1920.)

On the other hand, in the U.S.A., C.W. Seibel reported to the American Society of Chemistry in 1917 that the natural gas discovered in Kansas contained helium gas. In this report, he stated that he did not feel that helium is a useful resource. P.B. Moore of the Mining Agency, however, pointed out that helium extracted from natural gas would be a potential source for the future helium demand which he predicted would expand. Afterwards, the U.S.A. participated in World War I, and like England, considered the use of helium for balloons and airships. The U.S. army offered a fund to the Mining Agency for a survey of helium resources. As a result, the first large-scale helium-gas production plant was build in Fortworth, Texas, in 1921 with financial aid from the Navy, thus helium gas began to be extracted from natural gas at low temperature. /233

Helium is generated from alpha particles which are radiated according to the decay of heavy elements. It is for this reason that helium gas has been stored in the old rock formations of the earth's crust.

For example, heavy elements, uranium and thorium, generate 1.16×10^{-7} cc and 10^{-8} cc of helium gas per gram per year, respectively. Thus, in the whole earth, 8,000 to 30,000 thousand m^3 per year of helium gas is constantly generated under the ground. Such helium gas is dissipated from the ground to the atmosphere and ascends to the upper layer of the atmosphere. Therefore, the helium density in the upper layer of the atmosphere is increasing. In the lower layer of the atmosphere, however, it was said that the density of helium is held constant since the amount coming out of the ground is equal to the amount dissipated to the upper layer.

In the earth's layers, combustible natural gas is stored. This gas is now used for gas supply in cities or power generation in the form of -162° LNG (liquid natural gas). It was C.W. Seibel who discovered that this natural gas contains helium gas. The U.S. government realized the military importance of helium gas and enacted the Helium Act in 1925. According to this Act, the production and the distribution of the helium gas was exclusively managed by the Mining Agency. In the 1930's, non-governmental demand started to increase (e.g., deep-sea operation, caisson work, ultra-low temperature research, etc.). A part of the Act was amended so that helium gas might be sold for medical, research and engineering uses. However, helium gas is still regarded as military material and its export is strictly restricted

The second uprising of mass consumption of helium gas was provoked by World War II. In the early stages, its main use was for welding light alloy. However, large amounts of helium were also used for airships. Accordingly, the Mining Agency built four new helium wells and tried to increment the production of helium. At that time, the U.S. Navy had 150 anti-submarine patrol airships which guarded vessel fleets. It was said that the guarding efficiency of those airships was very high, almost 100%. In the 1950's, as space development projects started following missile development projects and as nuclear energy development plans began to be carried out, helium consumption began to increase at a vary rapid pace. Thus, the helium used in the U.S. and Europe had all been extracted from natural gas and not from the air until the beginning of the 1960's. Since then, several new uses of helium have been introduced. For example, helium is now a most convenient agent for detecting leaks. Since helium can be easily detected by a mass spectrograph, it is an ideal agent for detecting leaks of pipes or the like. Helium has begun to be used in copper welding and as a carrier gas in a gas chromatography as well. In addition, helium is used as a coolant gas for novel nuclear reactors. In deep-sea works, helium is a convenient gas which is combined with oxygen for respiration. Furthermore, in research institutes, ultra-low temperature laboratories use liquid helium as a cooling agent.

The U.S.A., startled by the first artificial satellite, the sputnik, launched by the Soviet Union in 1957, started to make full-scale efforts in space development competition. ICBM's such as Atlas and Titan, or space ship rockets use liquefied fuel and large amounts of helium gas. Thus, helium consumption was greatly increased.

Fig. V-3 shows the record of helium use in the U.S.A. The 1960's increase of helium use was stopped in 1966 when 948 million ft³ of Helium was consumed. Since that year, helium consumption has been decreasing.

ORIGINAL PAGE IS OF POOR QUALITY

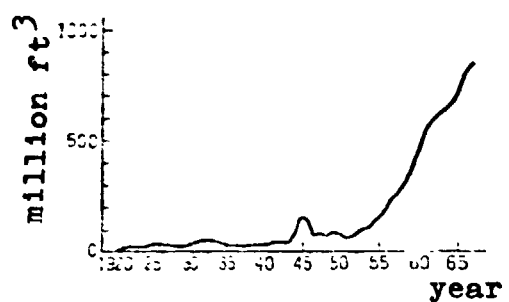

Fig. V-3. Record of Helium Use in the U.S.A.

V-1-2. Uses of Helium.

The uses of helium in the U.S.A. in 1966 and 1967 have been studied. In these years, helium consumption was at its peak. Fig. V-4 shows the fractions of helium use in 1967, and Fig. V-5 shows the fraction of helium users in 1966, both in the U.S.A. Fig. V-5 indicates the surprising fact that 90.6% was used in governmental projects, including 59.4% by NASA, 20.3% by military agencies and 8.9% by nuclear industries.

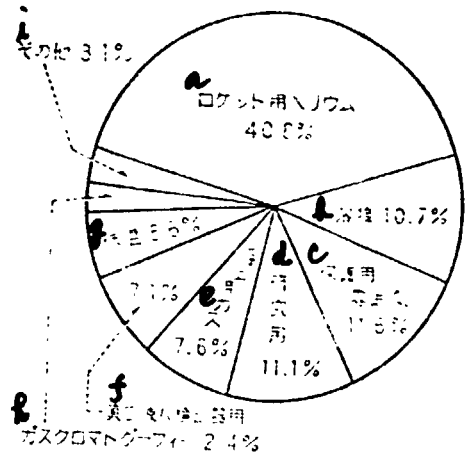

Fig. V-4. Uses of Helium in the U.S.A. (1967)

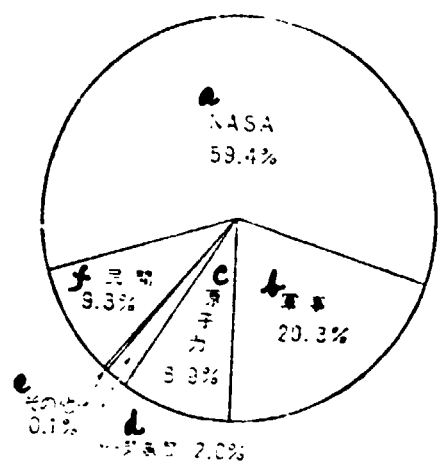

Fig. V-5. Users of Helium in the U.S.A. (1966)

Key to Fig. V-4.

a: Helium for Rockets: 40.8%
b: Welding: 10.7%
c: Safe Atmosphere: 11.6%
d: Laboratory Researches: 11.1%
e: Buoyant Gas: 7.6%
f: Leak Detecting: 7.1%
g: Low-Temperature: 5.6%
h: Gas Chromatography: 2.4%
j: Others: 3.1%

Key to Fig. V-5.

a: NASA: 59.4%
b: Military Agencies: 20.3%
c: Nuclear Power: 8.9%
d: Meteorological Agency: 2.0%
e: Others: 0.1%
f: Non-Governmental Agencies: 9.3%

It can be seen from the above figures, how peculiar helium gas is as a resource. The main uses shown in Fig. V-4 are described in the following:

(A) Helium for Rockets (Pressurizing and Pruging Gas):

This use occupies about 40% and is mainly connected with space development. The Pressurizing gas is the gas which sends the liquefied fuel to engines with pressure. Purging gas is the gas used for pushing the air out of vessels and pipes before filling them by liquefied hydrogen or oxygen.

(B) Welding:

In Japan, argon is mostly used in welding. In the U.S., however, helium is widely used for this purpose.

(C) Safe Atmosphere:

Mainly, helium gas is used for guarding active metals in a nuclear reactor taking advantage of its inactivity.

(D) Laboratory Researches:

Helium is used in laboratories for research. Mainly, it is used as liquid in wind tunnels and gas for space chambers.

(E) Buoyant Gas:

Mainly for balloons.

(F) Leak Detecting:

(G) Low-Temperature:

As liquid helium, it is used in ultra-low temperature researches in developing ultra-low temperature techniques.

(H) Gas Chromatography:

(J) Substitute Composite Air:

In deep-sea works such as caisson works or marine development operations, since the use of the air (which is the same as that in the atmosphere) may cause nitrogen poisoning, artificial air containing helium is used.

(K) Medical Uses:

Helium is used in high-pressure tank for curing submarine sickness.

V-1-3. Helium Resources.

In this section, helium resources are avaluated briefly.

One 200 million-th of the atmosphere is helium. Helium, as a resource, however, is that contained in the natural gas. Almost all

kinds of natural gas contain a small amount (several tenths to several hundredths %) of helium. In some cases, natural gas contains up to 9 % of helium. At present, the natural gas source containing 0.3 % or more helium and having a deposit of 100 million ft³ or more can be regarded as a helium resource. According to the 1969 survey on helium resources, about 20 billion ft³ of helium was evaluated as an existing resource, based on the above criteria. In order to evaluate the resource more precisely, productivity of each well, market conditions, land conditions for plants, uniformity of the gas, continuity, etc. should be taken into account. Thus, various estimates of effective (usable) amount of helium resource have been made. At present, the following estimates are considered reliable: Laverick of Argonne Nuclear Institute evaluated the resource in 1969 level to be 28.56 billion ft³. According to the evaluation made by Hogan of the CTi Company which is well-known worldwide for helium liquefying machines, it was estimated to be 10 billion ft³ or more. Professor Agohchi of Japan University and others made an estimation that it is around 15 billion ft³. In the U.S.A., 87 % of the helium resource is concentrated in three states, Kansas, Oklahoma and Texas. Fig. V-6 shows pipe lines for collecting helium gas. Except for the U.S.A., detailed data are not available. However, Canada produces 120 million ft³ of helium annually and exports a part of it. European countries and Japan are almost completely dependent on the U.S.A. and Canada for helium resources. It is estimated that countries in the communist bloc, especially the Soviet Union, produce a large amount of helium. This estimate is based on the achievement of space development in the Soviet Union. Therefore, those countries must have a significant amount of helium resource. However, details are not known.

Key to Fig. V-6.

- a: Colorado
- b: Kansas
- c: New Mexico
- d: Texas
- e: Oklahoma
- f: helium pipe line
- g: Gallup
- h: Amarillo
- i: Helium Plant
- j: Helium Storage Plant
- k: Natural Gas Source Containing Helium Gas
- l: Well for Storage.

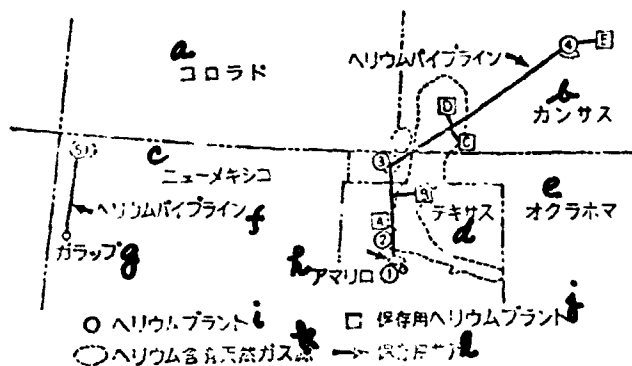

Fig. VI-6. Map Showing Helium Collecting and Preserving Plants in the U.S.A.

As mentioned previously, a large amount of helium is being wasted with natural gas.³ The amount of wasted helium in 1960 was estimated to be 6 billion ft³. If this condition continues, the resource helium is predicted to be exhausted in 30-35 years. /236

In summary, 100 billion ft³ to 180 billion ft³ of helium resources now exist in the U.S.A. As the demand for the natural gas increases, new sources of natural gas are being developed in various countries. Accordingly, new sources of helium gas are being discovered. For example, natural gas sources containing large amounts of helium were

recently discovered in Algeria and Poland. In these places, the collection of helium gas has already been initiated. Furthermore, if sources in Siberia of the Soviet Union and in China are included, the amount of helium resource may be increased. On the other hand, if the collecting technique is improved in the future, the evaluated percentage, 0.3 %, will be largely improved. According to Laverick's evaluation, helium up to 0.015 % will be able to be recovered in the future. Of course, this possibility is actually dependent on future economic conditions, i.e., dependent on how high the helium price will be.

V-1-4. United States' Plan for Preservation.

Recognizing the peculiarity of the helium resource, the U.S. government realized the importance of the helium gas mass-preservation plan and enacted the bill "Helium Preservation Plan" in 1960. According to the bill, it was decided that helium plants will continue to be operated under the management of the Mining Agency, and that the government will preserve helium in storage owned by the government. The helium for preservation is purchased from companies which make contracts with the government. The preservation storage is a gas source called Cliffside Gas Field which is the site where natural gas in the total amount of 58-billion-ft³ has been extracted since 1929. Natural gas is still being extracted. For preservation purposes, the emptied well is fed with helium gas (strictly speaking, the gas called "coarse helium" consisting of 71-% helium, 27-% nitrogen, 1-% hydrogen and 1% methane) through pipes, thereby preserving the helium gas under the ground. This gas source has the ability of storing 100 billion ft³ of gas. This ability is more than the expected amount for storage, 63.6 billion ft³. The government purchases the annual amount of 3.5 billion ft³ of "coarse helium gas" with the price of 18 billion yen annually. It was planned to preserve 63.6 billion ft³ in 22 years. This preservation plan began to be carried out in 1962. After the success of the landing of a manned space ship on the moon according to the Apollo Plan, critics spoke out against the space development and public opinion tended to be more in favor of social welfare than technological development. Accordingly, the scale of space development was forced to be reduced. Naturally, the government's demand for helium gas was largely reduced. The governmental use of helium decreased rapidly from 946 million ft³ in 1966 to 222 million ft³ in 1970. Even including non-governmental consumption, the total consumption of helium in 1970 was 222 million ft³, a sharp decline from the 1966 level of 948 ft³.

According to this fundamental change of situation, in 1971 the U.S. government declared a termination of the plan to preserve helium. Accordingly, the U.S. government cancelled coarse helium purchase contracts with four companies which had provided it to the government, reasoning that circumstances had changed fundamentally. The main cause of this termination was the drastic decrease in governmental helium consumption, corresponding to the large reduction of space development projects. However, other reasons can be pointed out beside this:

(1) It was judged that the future governmental (strategic) need for helium gas had already been stored under the preservation plan which had been carried out to that time. About 28 billion ft³ of storage was achieved in 1971 and this amount was judged to be more than necessary. Including the amount, 30 billion ft³, preserved by non-governmental agencies, the totally stored 237 amount will support 30 years of helium consumption at the present level.

(2) As the economic conditions in the U.S. become worse, the government could ignore the expenses for purchasing coarse helium, 18 billion yen annually. The above two reasons should be added for the reasons of the termination of the preservation plan.

V-1-5. Prospects for Future Helium Supply and Demand.

According to an estimation, out of the total consumption 13.3 billion ft³ of helium gas in 1971, 8.5 billion ft³ was dissipated with natural gas, about 4 billion ft³ was stored and 800 million ft³ was actually used. Therefore, if the consumption level continues to be at the present level, or even if it increases to twice or three times as much as the present consumption, the demand will probably be fulfilled at least for about 30 years.

One of the crisis feelings which were introduced in the 1970's was induced by the energy problem. Already, the U.S. had been changed from oil exporter to importer. Energy crisis was warned by many people. Besides this energy problem, sulfur pollution induced by the oil uses has made more dependence on the natural gas which contains much fewer sulfur component. Thus, the natural gas consumption has been increased year by year. Therefore, instead of preserving helium, preservation of the natural gas is felt to be more urgent. In this way, the preservation of helium has been challenged with increasing pressure by the effort of preserving natural gas against the wasteful use of it.

On the other hand, having started to deal with the energy problems and the social welfare, the scientific technology in 1970 has realized its new mission in developing ultra-low temperature techniques and ultra-conductivity techniques. The ultra-conductivity techniques are expected to be applied to magnetic floating trains, large-capacity generators with the capacity more than 3 MW and power transmission system over 3 MW. In addition, this technique is indispensable to ultra-conductivity magnet which confines the high-temperature plasma in a nuclear fusion reactor. The critical temperature is at most 20° K at the present level. If it could be increased by 15-10° K, ultra-conductivity techniques would be possible using liquefied hydrogen (with boiling point of 20°K) without using helium.

Development of a technique for separating helium from the air is one of the future possibilities. According to the present estimation, it will result in about 30 to 60 times higher price. However, considering the future when helium can be obtained only from low-content sources, it will be realized that increased value of helium may be balanced with decreased cost owing to the development of new techniques for separating helium from the air.

References

1. Agochi, Takashi, "Problems of Helium, " Teion Kogaku (Low-Temperature Technology), 5/3, 1971, (in Japanese).
2. Agohchi, Takashi, "Economics of Helium," Shizen (Nature), May, 1973, (in Japanese).
3. Teikoku Sanso Company, "On Helium," 1965, (in Japanese).
4. Monna, Gohei, "Outlook of Helium in the U.S.A.," Nihon Sanso Shiryo (Japan Databook of Oxygen), September, 1971, (in Japanese).
5. Monna, Gohei, "Recovery of Helium in Poland," Nihon Sanso Shiryo (Japan Databook of Oxygen), October 1973, (in Japanese).

V-2. Study of Laws Concerning Suspended Transport.

/238

Concerning suspended transport in the air, there is no description in Aviation Law (hereinbelow, referred as "the Law"). However, there are some descriptions concerning suspended objects connected to aircraft in Articles 240 and 242 of Aviation Administration Rule (hereinbelow, referred as "the Rule").

When the aircraft carry suspended cargoes, a route approval must be given according to the provisions in regard to an irregular transportation service, and an application must be filed for permission to land on a place which is not an air field and to fly at low altitude, according to Articles 79 and 81 of the Law, respectively.

With regard to conditions under which an irregular air transportation service connecting two points is permitted, there is no description in the Law, but the permission is given based on the judgment made by the Civil Aviation Bureau. This judgment is made after examining whether the following conditions are satisfied or not: In general, the route must avoid thickly resident area, and even when it crosses mountainous area, it must avoid the spaces over resident houses. When the route crosses over a National Road, a responsible agent such as a regional police department must be informed of it and a safe-guard procedure such as stopping the traffic must be taken accordingly.

Along the route, there must be sufficient number of open spaces to which the aircraft can make an emergency landing when the engines fail. Furthermore, the aircraft must keep sufficient altitude so that such an emergency landing may be done safely, and the aircraft's ability and the transportation conditions must be such that the above requirement may be satisfied.

With regard to landing outside air fields, Article 172 Number 2 of the Rule requires an application for the permission and it must be filed to Minister of Transport. According to Article 240 of the Rule, however, the director of each regional Civil Aviation Bureau is authorized to give such a permission. Whenever an air transportation service requires such a landing, an application must be filed giving the reason for it. With regard to rotary-wing aircraft (helicopters), the criteria for giving a permission of landing on a place which is not an air field are described in Article 75 of the Rule. These criteria are the same as those for ground heliports. According to the minimum condition required to such a place for landing, its length must be 1.2 times as long as the aircraft length and must be longer than 15 m.

With regard to loading and unloading of cargoes, besides the above requirement for the land, the admission slope criteria of Article 2 of the Rule and the transition surface slope criteria of Article 3 Number 3 of the Rule are applied.

In case of helicopter transportation for construction works of power transmission lines in mountainous areas, the slope of the admission surface must be at least one tenth and the slope of the transition surface must be at least one fourth. In case of transmission line construction, the horizontal surface radius provision of Article 3 of the Rule and the heliport admission zone length provision of Article 1 Number 2 of the Rule are not applied.

An application for low-altitude flight based on Article 81 of the Law must be filed according to the procedures described in article 175 of the Rule and the applied criteria for this application are described in Article 174 of the Rule.

The above criteria for the permission of the operation are now applied to helicopter transportation for power transmission line construction. In order to comply with these requirements, before starting a suspended bucket transportation of soft cement or transportation of tower frame members, trees are cut down to clear the required spaces in the neighborhood of the loading and unloading sites.

The Aviation Law.

-Landing and Take-Off Ground -

Article 79: Aircraft (excluding the aircraft classified by the provisions in the Ministerial Ordinance) shall neither take off from nor land on any ground which is not in an air field or on any water surface which is not in a place appointed by the Ministerial Ordinance. Provided that permission is granted by the Minister of Transport, such aircraft may take off or land in a place which is not an air field.

-Minimum Safe Flight Altitude -

Article 81: Except for take-off and landing, the aircraft shall not fly at an altitude lower than the altitude which is prescribed in the Ministerial Ordinance, for the sake of the safety of men and property on the ground or on the water. Provided that permission is granted by the Minister of Transport, this provision may be exempt.

The Aviation Administration Rule.

-Commission of Authorization -

Article 240: The following authorities of the Ministry of Transport, prescribed in the Law and the present Ministerial Ordinance, are committed to the director of the Aviation Bureau of the appropriate district:

- .
- .
- .
- .
- 25. The permission prescribed in the proviso of Article 79 of the law.
- .
- .
- .
- 27. The permission prescribed in the proviso of Article 81 of the Law.
- .
- .
- .

Article 242: The authorities listed in the upper portion of the following table are committed to the directors of the local Aviation Bureaus, Airport Offices or Airport Branch Offices which are listed in the lower portion of the same table.

.
. .
. .
. .

2. The authority prescribed in Article 240 Paragraph 27 Number 1. (Exclusively with regard to aircraft used in air cargo transportation services, aircraft which are operated by instrumental flight or night-time flight, and rotary-wing aircraft which suspend object outside their bodies or tow objects in the air.) The director of the local Aviation Bureau whose district of control includes the place where the action requiring this permission will take place.

- Aircraft Which can Take-Off and Land at a Location Which is not an Air Field -

Article 172-2: One who seeks the permission prescribed in the proviso of Article 79 of the Law must present to the Ministry of Transport two copies of an application form for permission to take-off and land at a location which is not an air field.

1. Name and Address.
2. Aircraft Model, Nationality and Registered Number.
3. Date and location of take-off or landing. (An outline map showing the vicinity of the location must be attached.)
4. Reason for take-off or landing.
5. Precautionary measures for preventing accidents.
6. Outlined flight plan. (The objective, the date and the route of the flight must be clearly described.)
7. Name(s) of pilot(s) and his (their) qualification(s).
8. Other matters for explaining this application.

-Kinds of Air Fields and Classes of Landing Zones -

Article 75: Airfields are classified into the four categories: ground air fields, ground heliports, on-the-water air fields and on-the-water heliports.

.
. .
. .

2. To which class a landing zone belongs is determined by the length of the runway when it is of a ground air field or a ground heliport, and by the length of the landing zone if it is of an on-the-water air field or an on-the-water heliport, according to the following table:

Ground Heliport Class	Runway Length
A	90 m or longer
B	from 40 m to 90 m
C	from 15 m to 40 m
D	15 m or shorter and 1.2 times as long as the projection area of the aircraft or longer.

- Length of Admission Zone of Heliports -

Article 1.2: The length of the admission zone of a heliport, prescribed in Article 2 Paragraph 6 of the Law, is determined by the kind of the heliport and the class of the landing zone thereof, according to the following table:

Kind of Heliport	Class of Landing Zone	Length of Admission Zone
Ground Heliport	A	2,000 m
	B	1,500 m
	C	1,000 m
	D	2,000 m or less Length is specified by the Ministry of Transport.

- Slope of Admission Surface -

Article 2: The slope of the admission surface with respect to the horizontal surface, prescribed in Article 2 Paragraph 7, is determined as follows:

1. The slope of a landing zone through which aircraft land using instrumental landing means or through which aircraft land by a landing guide using precise admission radar means is one fiftieth.

2. If a landing zone does not correspond to the description prescribed in the above paragraph, the slope is determined by the kind of the air field and the class of the landing zone according to the following table:

Kind of Air Field	Class of Landing Zone	Slope
Ground Heliport	A	1/20
	B and C	1/10
	D	1/10 or greater and 1/4 or less.
		The slope is specified by the Ministry of Transport.

-Slope of Transition Surface of a Heliport-

Article 3-2: The slope of the transition surface of a heliport, prescribed in Article 2 Paragraph 9 of the Law and determined by the Ministerial Ordinance, is one fourth.

.

.

.

2. Even when a heliport is applicable to the description in the above paragraph, the slope of one longer side (hereinafter referred to as Side A) of the landing zone can be determined according to the provisions prescribed in the following two sub-paragraphs, if, in the range which is outside the other longer side (hereinafter, referred to as Side B) and within the distance twice as long as the length of shorter sides of said landing zone, there is no building crossing the surface which includes Side B and has the slope of one tenth.

(i) The slope specified by the Minister of Transport.

Said slope must be more than one fourth and the provision in this paragraph is applicable only when, in the range which is outside Side A and within the distance three-fourths of the diameter of the rotary wings of the helicopters which are expected to use said heliport, there is no object protruding /240 from the horizontal surface including the highest point of the landing zone.

(ii) The slope specified by the Ministry of Transport.

Said slope must be within the range from 1/4 to 1/1 and this provision is applied when the above provision is not applied.

-Radius of Horizontal Surface -

Article 3: The radius of a horizontal surface, prescribed in Article 2 Paragraph 8 of the Ministerial Ordinance, is determined by the kind of the air field and the class of the landing zone (the longer landing zone if the air field has two or more landing zones), according to the following table:

Kind of Air Field	Class of Landing Zone	Radius
Ground Heliport	A	800 m
	B	600 m
	C	400 m
	D	800 m or shorter The radius is specified by the Minister of Transport.

-Lowest Safe Altitude-

Article 174: The lowest safe altitude prescribed in Article 81 of the Law is determined as follows:

1. If the aircraft is operated by visual flight, the lowest safe altitude is the altitude from which the aircraft can make a safe landing without causing any danger to men or property on the ground or the water when the power means fail during the flight, or the altitude which is the highest among those described in the following sub-paragraphs:

- (a) The altitude 300 m or more higher than the top of the tallest obstacle within the range of the circle with the center at said aircraft and the radius of 600 m, when the aircraft is above a thickly populated residential area or an area crowded with people.
- (b) The altitude at which the aircraft can fly keeping the distance of 150 m or more from men or property on the ground or water, if the aircraft is above an area without any man or any property or above wide open water.
- (c) The altitude 150 m or more higher than the ground or the water surface, if the aircraft is above an area which is not described in the above two sub-paragraphs (a) and (b).

2. The altitude determined by a Ministerial Order, if the aircraft is operated by instrumental flight means.

-Permission of Minimum Safe Altitude Flight -

Article 175: The one who seeks the permission prescribed in the proviso of Article 81 of the Law shall submit an application to the Ministry of Transport which describes the following items:

1. Name and Address.
2. Aircraft model, nationality and registered number.
3. Outlined Flight Plan (The objective, the date and the route of the flight must be clearly described.)
4. Reason for flying under the minimum safe altitude.
5. Name(s) of pilot(s) and his (their) qualification(s).
6. Name(s) of on-board member(s) other than pilot(s) and the reasons for boarding.

Fig. V-7. Take-Off and Landing Site for Rotary-Wing Aircraft.

図イ 着陸帯, 進入表面, 転移表面の平面図

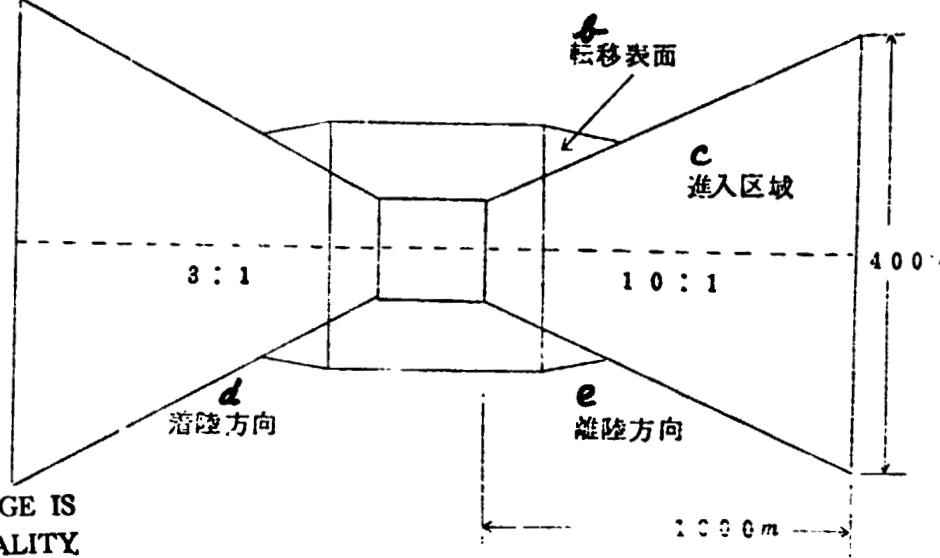

ORIGINAL PAGE IS OF POOR QUALITY

図ロ 進入表面, 着陸帯断面図

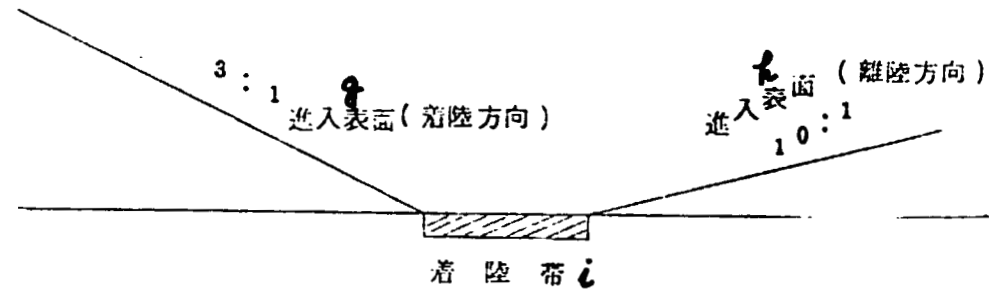

図ハ 進入表面, 進入区域, 移転表面の立体及び断面図

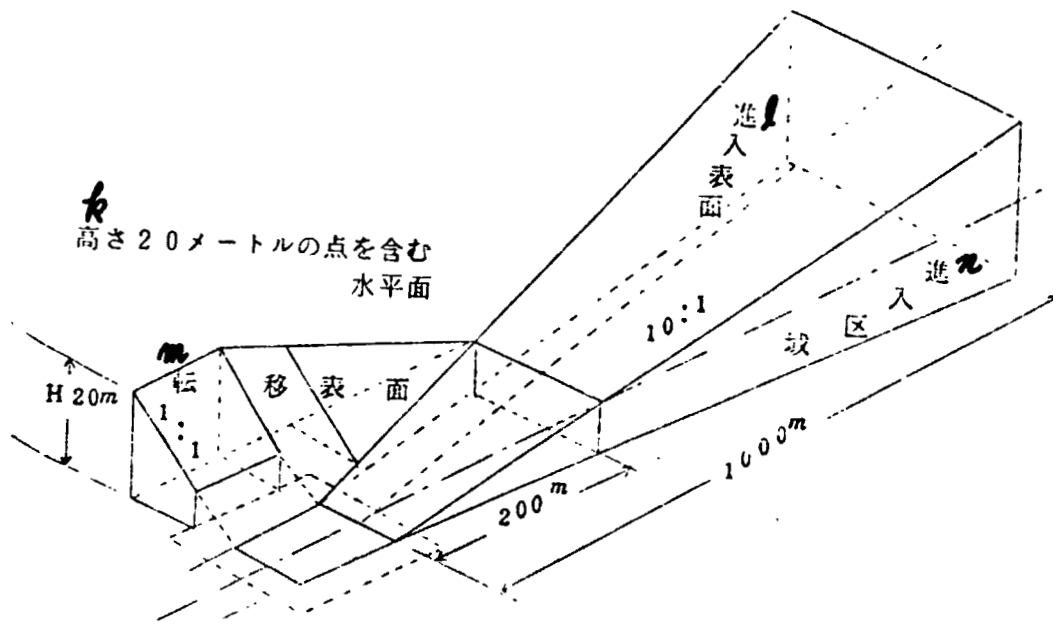

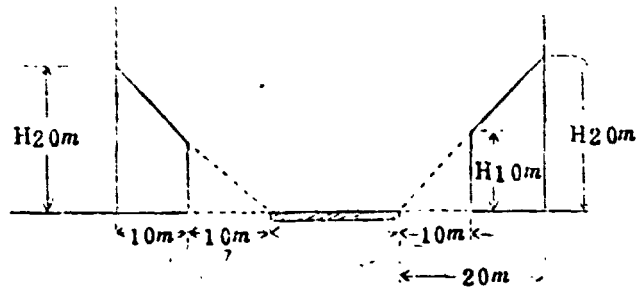

着陸帯の外側10メートルの範囲内に着陸帯の表面の延長面上に出る高さの障害物がない区域

P
 (面二) 障害物件が制限区域内にある場合
 進入表面, 移転表面平面図

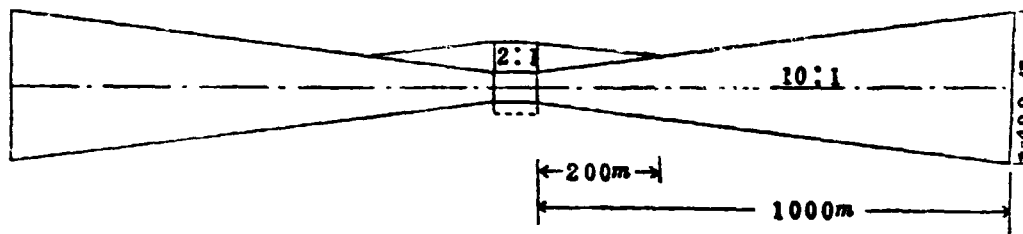

Q
 立体図
 (転移表面に出る障害物件がある場合)

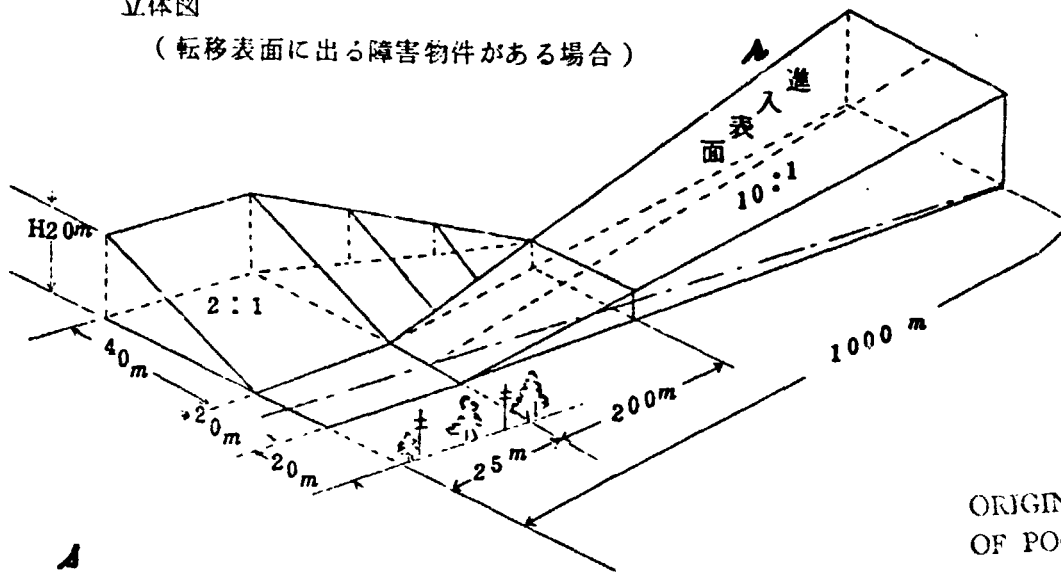

ORIGINAL PAGE IS OF POOR QUALITY.

A
 断面図
 (転移表面に出る障害物件がある場合)

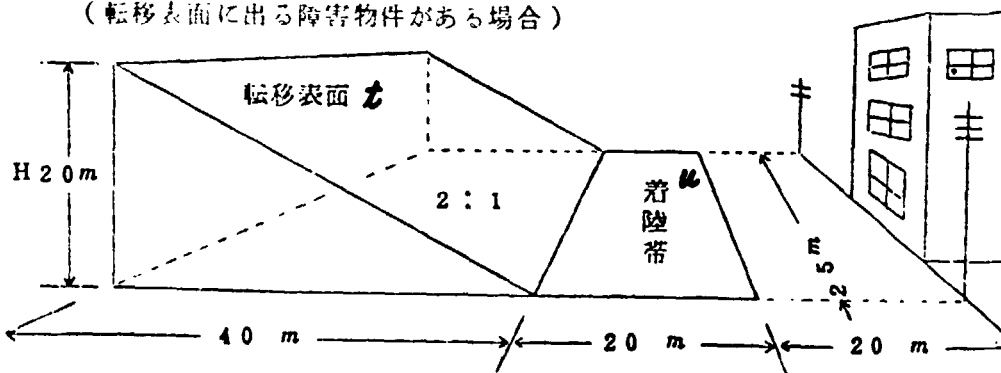

最低安全高度の規定

(1)

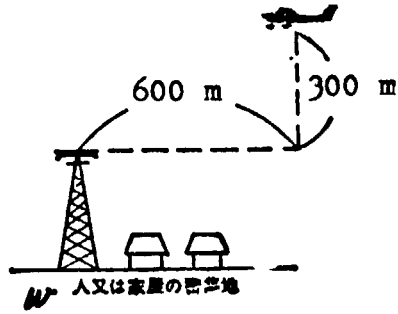

ORIGINAL PAGE IS
OF POOR QUALITY.

(11)

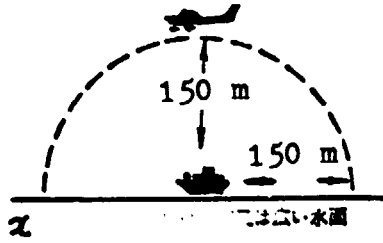

(111)

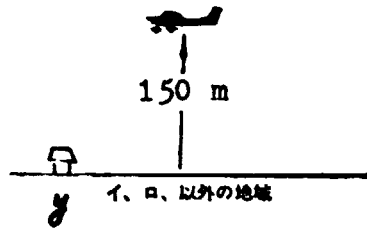

Key to Fig. V-7.

- a: Fig. (a) Ground View of Landing Zone, Admission Surface and Transition Surface.
- b: Transition Surface
- c: Admission Surface
- d: Landing Direction
- e: Take-Off Direction
- f: Fig. (b). Cross Section of Admission Surface and Landing Zone.
- g: Admission Surface (Landing Direction)
- h: Admission Surface (Take-Off Direction)
- i: Landing Zone
- j: Fig. (c). Perspective View and Cross Section of Admission Surface, Admission Zone and Transition Surface.
- k: Horizontal Plane Including 20-m Height Point.
- l: Admission Surface.
- m: Transition Surface
- n: Admission Zone
- o: Region 10-m outside the Landing Zone Where There is No Obstacle Protruding the Extensions of Landing Zone Surface.
- p: Case Where Obstacle is in the Restricted Region. Ground View of Admission Surface and Transition Surface.
- q: Case Where Obstacles Protrude the Transition Surface. Perspective View.
- r: Admission Surface
- s: Case Where Obstacles Protrude the Transition Surface. Perspective View.
- t: Transition Surface.
- u: Landing Zone.
- v: Definition of Minimum Safety Altitude.
- w: Area Crowded with Men and Houses.
- x: Area Without Man or House or Widely Open Water.
- y: Area Not Classified into (i) or (ii).

Chapter VI. Comprehensive Evaluation

CONTENTS

/244

VI-1. Evaluation of the Hybrid LTA Chosen as Objects for This Survey.....	315 (244)
VI-1-1. Outline.....	315 (245)
VI-1-2. Hybrid Airships for Regular Passenger Transportation.....	317 (246)
(a) Comparison of Conventional Transportation Means and Rota-Ship in Existing Transportation Routes.....	317 (246)
(b) Possibility of Cost Reduction of Rota-Ship....	332 (257)
(c) Noise Problem.....	333 (258)
(d) Problem of Fuel Consumption.....	333 (258)
(e) Marketability in Oversea Markets.....	333 (258)
(f) Influences to Fields outside Passenger Transportation.....	335 (260)
VI-1-3. Hybrid Airships for Heavy Cargo Transport.....	336 (260)
(a) Rental Charge of Skycrane and Rota-Ship.....	336 (260)
(b) Performance of Skycrane.....	338 (262)
(c) Performance of Rota-ship (for Heavy-Cargo Transportation).....	339 (262)
(d) Demand in the Market.....	339 (262)
VI-2. Comprehensive Evaluation of LTA Aircraft as a Whole....	346 (267)

The comprehensive evaluation presented in this chapter has two main objects. One of them is the evaluation of the hybrid LTA chosen as targets for this survey.

/245

The other object is to review various LTA aircraft which have been surveyed for the past three years and include the hybrid LTA aircraft surveyed for this report and to make an overall evaluation.

VI-1. Evaluation of the Hybrid LTA Chosen as Objects for This Survey.

VI-1-1. Outline.

The objects chosen for this survey study and their functional characterizations are as follows:

- | | |
|--------------------------|--|
| (1) Passenger Rota-Ship: | Regular Passenger Transportation
Payload: 10-ton class (120 passengers) |
| (2) Skycrane: | Heavy Cargo Transportation
Payload: 40 tons and 70 tons
Aero Crane Type. |

- | | |
|------------------------------|--|
| (3) Heavy Cargo Rota-Ship: | Heavy Cargo Transportation
Payload: 30 tons
Helistat Type |
| (4) Megalifter Type Airship: | Heavy Cargo Transportation
Only the performance properties have been studied for this report. |

Among the above aircraft, it is (1) Rota-Ship (for passenger transportation) that is technologically the most realizable and economically the most marketable.

At the time when we started this survey study, we felt a suspicion that LTA aircraft might be infeasible as passenger transportation means and an anticipation that LTA aircraft might be used only in a very special field where there is no alternative means. However, as a result of the study, we came to conclude that the LTA aircraft for regular passenger transportation are the most promising among other possible uses of LTA's.

Actually, in Japan, the Heli-Stat type hybrid airships are very promising candidates for the future aircraft of passenger transportation. Needless to say, conceptualizing designs presented in this report are not necessarily optimal designs. However, the result of the study on Heli-Stat type airships (for passenger transportation) has made it clear that, when a new type of transportation aircraft is sought for development, comparative studies of LTA aircraft will be indispensable as well as studies of conventional HTA aircraft, and that, at least, LTA aircraft are qualified to be compared with conventional HTA aircraft.

On the other hand, considerably expanded market demand in the future is anticipated in the field of heavy cargo transportation. However, within the scope of this survey study, we have concluded that corresponding technical means (we call "seeds") will not reach the market in the near future. Nevertheless, the distance between the "seeds" and "needs" are not too long to make linkage between the two. It may be rather concluded that accumulation of the technical achievements is now too little in Japan and that, consequently, there is no technology which matches the needs exactly. As further studies of the kind presented in this report are repeated, a new type of craft which can satisfy the needs will appear. Strictly speaking, it is more likely that the needs will be satisfied by a new type of craft than the possibility that the needs will never be satisfied. /246

Between the Aerocrane type and the Helistat type, the latter will probably be more easily built with less cost than the former. The Aerocrane, however, include uncertain elements - As a flying object, it is possible to maintain the stable flight?

On the other hand, many feel that the Helistat type airships have little problem in technical realizability. However, the Helistat type airships will be more expensive than the Aerocrane of the same ability of carrying heavy cargoes. This is one of the results of this survey study.

The study on Megalifter type airships was done only for looking over the possibility of its use in regular cargo transportation means, as stated in the section explaining the scope of this study. Within this scope, we did not study the feasibility of the airships of this type.

The auto-pilot means for suspended gondola will be a very convenient tool when LTA aircraft are widely used. This device will be combined with hybrid LYA's as well as with conventional airships.

VI-1-2. Hybrid Airships for Regular Passenger Transportation.

The outlook of the specifications, the performance properties and the economical efficiencies of the Rota-Ship for passenger transportation are summarized in Tables VI-1, VI-2 and VI-3.

Tables VI-4 through VI-11 show the condition of the competition of the Rota-Ship and the conventional aircraft in several existing short-distance airlines in Japan assuming that the Rota-Ship were introduced to such lines. (Several lines will be cited from the North to the South of the Japan Islands.)

(a) Comparison of Conventional Transportation Means and the Rota-Ship in Existing Transportation Routes.

Brief explanation will be given to each of Tables VI-4 through VI-11 which show the result of the comparison.

-Fig. VI-4: Sapporo to Hakodate/Aomori Line -

The existing airline does not reach Aomori. Long distance travellers, for example, from Tokyo to Sapporo, will prefer the direct flight to the destination. However, judging from the present (poor) conditions of transportation in the area between Sendai City and Hokkaido, it will be advantageous for this district to have large-size aircraft transportation services, even when such transportation means are compared with the existing railway and ship networks.

Table VI-1. Basic Specifications of Passenger Rota-Ship.

/247

		Specifications	Remarks
Gross Weight		32 tons	Ascent Limit: 3,000 m (Cruising Altitude: 1,500 m) 10 minutes of Hovering
Payload		14 tons	
(Fuel Weight)		(3.7 tons)	
(No. of seats)		(120)	
Cruising Speed		150 km/h (max: 170 km/h)	
Distance of Cruise		600 km	
Duration of Cruise		6 hours	
Size	Hull Length	80 m	
	Maximum Diameter	52 m	
	Maximum Height	32 m	
	Hull Volume	27 thousand m ³	
Pro- pul- sion	Gondola Length	25 m	6 Seats x 20 Columns 4 units of Rotor Systems of BK-117 Helicopter
	Gondola Width	6 m	
	Engines	4 Units x 2 x 600 HP	
	Rotors		
Crew Members		4 persons	
Price		150 million yen (226 million yen)	When Ten Aircraft are Built. (When one aircraft is built.)

Table VI-2. Comparison of Performance Properties.

/248

	Rota-Ship	YS-11	DHC-6	DHC-7	Jetfoil
No. of Seats	120	60 - 64	20	54	280
Cruising Speed (km/h)	150	475	130-190	434	80
Distance of Cruise (km)	600	2,330	1,280	1,120-2,900	500-700
Take-Off and Landing Runway	(500 m)	1,200 m	600 m (ca.)	770 m (ca.)	Harbor
Engines	600 HP x 2 x 4	3,000 HP x 2	650 HP x 2	1,174 HP x 4	3,800 HP x 2
No. of Crew Members	4	2	2	2	
Price (million yen)	1,500	650	270	1,000	2,800

Table VI-3. Comparison of Economic Efficiency

	Rota-Ship	YS-11	DHC-6	DHC-7	Jetfoil
Craft Price (million yen)	1,500	650	270	1,000	2,800 (ca.)
Price per Seat (mil- lion yen)	12.5	10 (ca.)	13.5	18.5	
Direct Operating Cost	19.1* yen/seat /km	13.2* yen/seat /km			
Total Operating Cost	28.6* yen/seat /km	23.6* yen/seat /km			Fare 67 yen /seat/km
Scale of Mass Production	10	180	491 (**)	25 (**)	
No. of Seats	120	60-64	20	54	280

Remarks:

- (*) 1977 yen. 300-km lines in Japan.
 (**) Orders received up until the end of 1975.
 Rota-Ship: The operating cost is 21% higher than that of the YS-11.
 YS-11: Production has stopped. At present, substitute aircraft are being sought.
 DHC-6: At present, used in an airline connecting isolated islands. Manufactured in Canada. 68% of the purchase price was paid by the government.
 DHC-7: 19 aircraft had been sold by the end of 1975. 25 aircraft orders had been received by that time. According to one source, this aircraft will be introduced into a certain airline in the near future. However, this information has not been confirmed.
 Jetfoil: Successful cruise in Niigata - Sado Line. Manufactured by the Boeing Company.

Substitute Aircraft for the YS-11: The following properties are desired:

- (A) Economical efficiency comparable to the YS-11. (20 % better if possible)
- (B) Noise level as low as the YS-11.
- (C) The ability to take-off and land on a runway shorter than 1,000 m. (STOL ability)
- (D) Use of common aircraft body and parts.

Table VI-4. Sapporo - Hakodate/Aomori Line.

124

	Fare	Required Time	Line Distance	Line Speed	No. of Passenger x No. of rounds
Railway/Ship	7,300 yen	8 hours 15 min. land: 4h 25 m. sea: 3 h 50 m.	432 km land: 319 km sea: 113 km	52 km/h	ca. 700 x 6 rounds per day
Conventional Aircraft	5,500 yen (Sapporo - Hakodate)	50 m.	160 km	192 km/h	130 x 3 rounds per day (1) 60 x 1 round per day (2) 20 x 1 round per day (3)
Passenger Rota-Ship	-----	2 hours or slightly less	260 = 150 + 110	150 km/h	120 x ?

Remarks:

Railway/Ship:

- 1) Express train, first class.
- 2) Muroran Main Line.
- 3) 1,300-passenger and 55-freight-car ferry boat.

Conventional Aircraft:

- (1) DC-9
- (2) YS-11/ Total Operating Cost = about 25 yen per seat per km
- (3) DHC-6

- Passenger Rota-Ship: 1) Total Operating Cost = about 30 yen per seat per km
- 2) The cruise to Muroran and Hakodate is possible.

Making rough assumptions on the relationship between the fare and the total operating cost as follows, a formula has been derived to represent this relationship: (It should be noted, however, that the actual fare will be determined also by competitive transportation means. Even an operation with deficit will be possible if the company has other very profitable lines. These factors are neglected in this derivation.)

$$D = A \times B \times C \quad , \text{ and}$$

$$F = D + E.$$

where

- A: the total operating cost per seat per km,
- B: the passenger capacity,
- C: the line distance (km),
- D: the expenses required for operating one aircraft in the line,
- E: the profit plus other admissible expenses for growth and others, and,
- F: the total amount that the airline company must collect from the passengers for operation of one aircraft.

In the U.S.A., it is estimated that (E) is about 12% of (F). Letting the load factor be denoted by L (%),

$$G = b \times L,$$

where (G) is the actual number of the passengers, and

$$H = F/G$$

where (H) is the fare which must be paid by the actual passengers.

Applying the above formula to the Sapporo- Hakodate Line (YS-11) shown in Fib. VI-4, we have,

/250

- A: TOC: 25 yen/seat/km
- B: Passenger Capacity: 60 passengers
- C: Line Distance: 160 km
- D: 240 thousand yen
- E: 20% of F (Probably, 20% is an over-estimate.)
- F: 240 thousand yen/0.8 :300 thousand yen
- G: 60 x 66% :40 passengers
- H: 300 thousand yen/40 :7,300 yen

where (L) is 66%.

However, the present fare is 6,500 yen. Probably, this fare is equalized to that of the DC-9 (130 passengers x 3 rounds per day).

Maybe, the YS-11 (1 round per day) and the DHC-6 (1 round per day) in the Sapporo - Hakodate Line are both not profitable for the airline operating company.

On the other hand, if the Rota-Ship is operated between Sapporo and Aomori under the same conditions, we have,

A: Total Operating Cost:	30 yen per seat per km
B: Passenger Capacity:	120 passengers
C: Line Distance:	260 km
D:	936 thousand yen
E: 20% of F	
F: 983 million yen / 0.8:	1,170 thousand yen
G: 120 x 66%	80 passengers
H: 1,170 thousand yen / 80:	14,625 yen

where (L) is 66%.

The computed fare is about twice as much as that of the railway/ship, while the required time is reduced to the one fourth.

The Shimonoseki - Pusan Line is an international line. However, its character is very similar to that of the Aomori - Hakodate Line. The Shimonoseki - Pusan Line is about 200 km long.

-Table VI-5: Sapporo-Abashiri (Memambetsu) and
Table VI-6: Sapporo-Kushiro (via Obihiro) -

In both lines, Sapporo is the origin. The two lines have a common character. The Sapporo - Wakkanai Line may be similarly characterized. In these lines, if the Rota-ship is scaled up so that it may accommodate 180 to 200 passengers and the cost may be reduced to the level of the YS-11, transportation by Rota-Ship will be sufficiently competitive with the railways.

Table VI-5. Sapporo - Abashiri (Memambetsu) Line.

/251

	Fare	Required Time	Line Distance	Line Speed	No. of Passenger x No. of Rounds
Railway	7,500 yen	5 hours 40 min.	375 km	66 km/h	ca. 700 x 2 rounds per day
Conventional Aircraft	7,700 yen	55 min.	250 km	273 km/h	60 x 4 rounds per day
Passenger Rota-Ship	-----	1 hour 40 min.	250-260 km (*)	150 km/h	120 x ?

Remarks:

- (*) Via Asahikawa
 Railway: 1) Express Train, First Class.
 2) Via Asahikawa
 Conventional Aircraft: 1) YS-11, Total Operating Cost = ca. 25 yen per seat per km.
 Passenger Rota-Ship: 1) Total operating cost = ca. 30 yen per seat per km.

Table VI-6. Sapporo - Kushiro (Via Obihiro) Line.

	Fare	Required Time	Line Distance	Line Speed	No. of Passenger x No. of Rounds
Railway	7,700 yen	5 hours 40 min.	396 km	69 km/h	ca. 700 x a 3 rounds per day
Conventional Aircraft	8,000 yen	40 min.	240 km (*)	360 km/h	130 x 4 rounds per day (1) 60x
Passenger Rota-Ship	-----	1 hour 40 min.	240 km	150 km/h	1 round per day (2) 120 x ?

Remarks:

- (*) Straight Line Distance
 Railway Express Train of the Japan National Railways
 Conventional Aircraft: (1) DC-9
 (2) YS-11: TOC = 25 yen per seat per km.
 Passenger Rota-Ship: TOC = ca. 30 yen per seat per km.

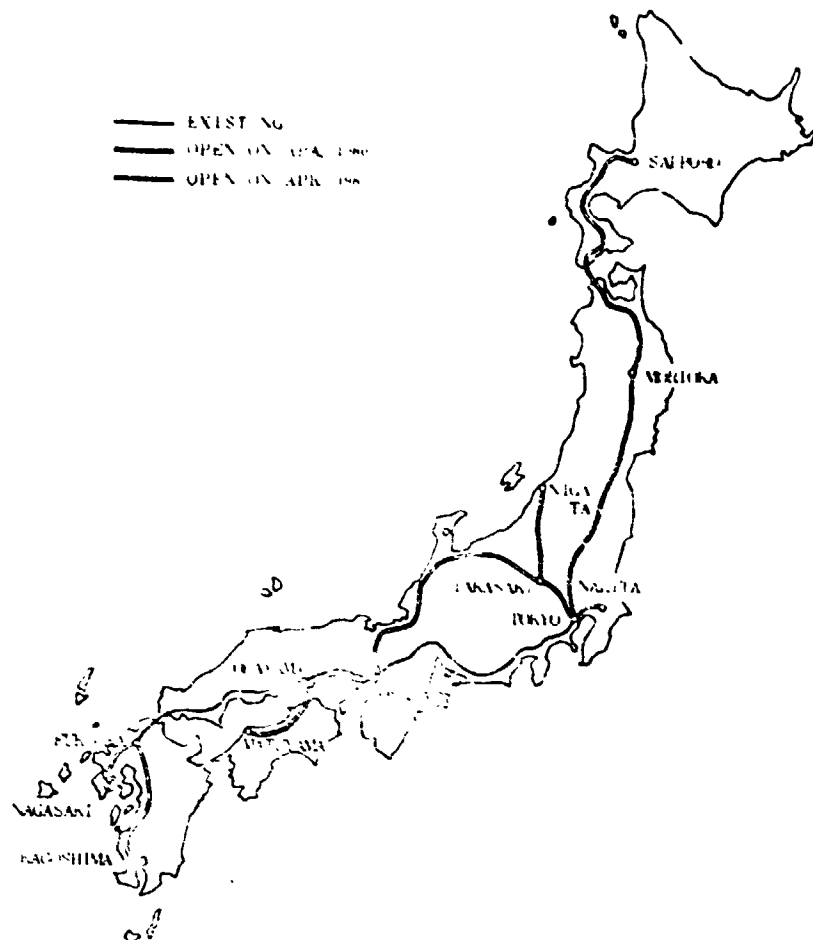

Fig. VI-1. JNR Super-Express Network Development Plan.

Remarks:

- 1) Total line length planned: 4,000 km.
- 2) The lines now under construction or survey work will be the only lines which will be operated in the future.
- 3) The start of the operation is planned for 1980 for those now under construction and 1985 for those now under survey work.

Furthermore, in connection with the super-express network development plan of the Japan National Railways (See Fig. VI-1), the operation of the Rota-Ship should be studied with respect to the comparison of the huge budget for the railway construction plan with the introduction of the Rota-Ship, especially as part of the general plan for developing the transportation network in Hokkaido after 1985.

ORIGINAL PAGE IS
OF POOR QUALITY

-Table VI-7: Tokyo - Izu-Ohshima/Miyake-Jima Line -

In this line, the Rota-Ship roughly designed in this report may be sufficiently competitive. Although there is an air transportation demand of over 1.5 million passengers per year at present, the air services are substantially restricted by the problems of the airports on the isolated islands (runway length) and of the airports on the mainland (airport capacity). Thus, the possibility of the introduction of large-size HTA aircraft is very limited. However, the possibility of introducing high-speed ocean liners such as the Jetfoil in the Sado Line is great.

Table VI-7. Tokyo - Izo Ohshima I./Miyake-Jima I. Line.

		Fare	Required Time	Line Distance	Line Speed	No. of Passenger x No. of Rounds
Ships	Ohshima I.	3,380 yen	4 h (day) 7 h (night) (*)	120 km	30 km/h (17)	ca. 1,700 x 2 rounds per day
	Miyake I.	4,970 yen	7 h (*)	180 km	26 km/h	ca. 1,200 x 1 round per day
	Ohshima I. - Tokyo - Atami	6,610 yen	2 h and 30 min.	120 km	48 km/h	ca. 300 x 1 round per day
Conventional Aircraft	Ohshima I.	3,500 yen	40 min.	120 km	180 km/h	60 x 1 round per day
	Miyake I.	5,500 yen	55 min.	180 km	196 km/h	60 x 1 round per day
Passenger Rota-Ship	Ohshima I.	-----	50 min.	120 km	150 km/h	120 x ?
	Miyake I.	-----	1 h and 10 min.	180 km	150 km/h	120 x ?

Remarks:

(*)

Ships: Ohshima I.:

Miyake I.:

Ohshima I.-Atami-Tokyo:

Direct Route:

- 1) 3,000-ton-class passenger-only ship.
 - 2) 1,700 passengers.
 - 3) 800 thousand passengers of annual demand.
- 1) 2,300-ton-class.
 - 1) Ohshima - Atami: 300 passenger high-speed ship
 - Tokyo-Atami: Super Express Train

Conventional Aircraft:

- 1) YS-11, TOC = ca. 25 yen per seat per km.
- 2) There is no cruising line.
- 3) Ohshima Airport: 1,200 m x 30 m.
Miyake Airport: 1,100 m x 30 m.

Passenger Rota-Ship:

- 1) TOC = ca. 30 yen per seat per km.

-Table VI-8: Kochi - Osaka Line -

/254

Every line connecting main cities in the Kansai District and Shikoku has the same character as the Osaka - Kochi Line. The largest number of and the most frequent service of YS-11's are provided by this group of airlines. Since every line crosses Seto Inland Sea, it has a great advantage over railway transportation. The Osaka - Matsuyama Line has the longest line distance, about 270 km. This distance implies that the introduction of large-size jet planes may not be motivated by high-speed, but only by mass-transportation ability. The Osaka - Tokushima line has a distance of about 120 m. In its case, demand has reached the limit and furthermore the line is struggling with the problem of noise. The major lines connecting Osaka and the cities in Shikoku are:

Osaka - Takamatsu:	10 rounds per day,	140 km
Osaka - Tokuyama:	12 rounds per day	120 km
Osaka - Matsuyama:	6 rounds per day	270 km

Table VI-8. Kochi - Osaka Line.

	Fare	Required Time	Line Distance	Line Speed	No. of Passenger x No. of Rounds
Railway/Ship	9,130 yen	5 hours 30 min. - 6 hours	390 km	66 km/h	ca. 500 x 3 rounds per day
Conventional Aircraft	6,100 yen	55 min.	225 km	240 km/h	60 x 23 rounds per day
Passenger Rota-Ship	-----	2 hours	225 km	150 km/h	120 x ?

Remarks:

Railway/Ship:

- 1) Express Train.
- 2) Takamatsu - Ube: Hovercraft.
- 3) Okayama - Osaka: New Super Express JNR Train.
- 4) Passenger Capacity: 500 - 1,000.
- 5) Express Fare plus First Class Fare.
- 6) Uko Ferry Boat Line: 2,350 passengers plus 27 freight cars.

Conventional Aircraft

- 1) Osaka and Kochi Airports: 25 min. from the center of the city by taxi.
- 2) YS-11: TOC = ca. 25 yen per seat per km.
- 3) Cruising Speed = 475 km/h.

Passenger Rota-Ship:

- 1) TOC = ca. 30 yen per seat per km.

Although the Osaka - Yonago Line, the Osaka - Izumo Line and other lines connecting Osaka and the cities in the San'in District are all on-the-ground lines, air transportation is significantly advantageous in these lines. The railway networks run through very mountainous areas and their line distances are much longer than straight-line distances. However, the growth of air transportation has been limited, mainly by the saturation of the airport capacity.

Osaka - Yonago:	YS-11:	1 hour, 5 rounds/day, Straight-Line Distance: 230 km.	<u>255</u>
	Railway:	6 hours, Line Distance: 345 km.	
Osaka - Izumo:	YS-11:	1 hour, 5 rounds/day, Straight-Line Distance: 270 km.	
	Railway:	7 hours, Line Distance: 407 km.	

-Table VI-9. Fukuoka - Tsushima/Iki Line -

The Nagasaki - Fukue Line (Goto Is., 3 rounds per day) will be characterized similarly to the Fukuoka - Tsushima/Iki Is. Line. The Kita-Kyushu - Pusan Line (about 210 km), an international line, is also a similar line. The disadvantage of the conventional HTA aircraft is in its inability to cruise along the islands due to the short distances between islands. If the Rota-Ship is operated in a cruising line connecting the islands, the Rota-Ship designed in this report may be competitive in these lines. (cf. The extension of Tsushima Airport's Runway from the present 1,500 m to 2,000 m, in order that jet planes may take-off and land is included in the Third Airport Consolidation Plan. The construction budget is 6 billion yen.)

Table VI-9. Fukuoka - Tsushima/Iki Is. Line.

		Fare	Required Time	Line Distance	Line Speed	No. of Passengers x No. of rounds
Ship	Iki I.	2,280 yen	2 hours 40 min.	76 km	29 km/h	ca. 500 x 1 - 2 rounds/day
	Tsushima I.	3,980 yen	4 hours 50 min	147 km	30 km/h	ca. 500 x 1 - 2 rounds/day
Conventional Aircraft	Iki I.	3,000 yen	30 min. (*)	76 km	150 km/h	60 x 3 rounds/day
	Tsushima I.	6,000 yen	40 min. (*)	147 km	220 km/h	60 x 4 rounds/day
Passenger Rota-Ship	Iki I.	-----	30 min.	76 km	150 km/h	120 x ?
	Tsushima I.	-----	ca. 1 h.	147 km	150 km/h	120 x ?

Remarks:

(*) Direct Flight
 Ship: 1) 7 ships of 500-ton to 1,500-ton class.
 2) Passenger Capacity: 200-600.
 3) Annual Passenger Transportation:
 250 thousand passengers (Tsushima)
 300 thousand passengers (Iki)

Conventional Aircraft:
 1) YS-11: TOC = ca. 25 yen per seat per km.
 2) Iki Airport: 1,200 m x 30 m
 Tsushima Airport: 1,500 m x 45 m

Passenger Rota-Ship:
 1) TOC = ca. 30 yen per seat per km.
 2) Cruising line is possible.

- Table VI -10: Kagoshima - Yaku/Tanega Is. Line -
 This line has a character similar to that of the Fukuoka - Tsushima Line. Probably, the Rota-Ship designed in this report might be competitive in this line, too. In this line, the flight services are low compared with the annual passenger demand, the line distance is too short to introduce large-size jet planes, and the runways are too short to be used by jet planes.

Due to the distance between the two islands, Tanega and Yaku Is., the triangular line connecting these islands and Kagoshima City is impossible for the conventional HTA aircraft. The operation of this triangular line will be made possible by the Rota-Ship.

Table VI-10. Kagoshima - Yaku/Tanega Is. Line.

/256

		Fare	Required Time	Line Distance	Line Speed	No. of Passengers x No. of Rounds
Ship	Tanega I.	4,000 yen	3 hours (*)	120 km	40 km/h	ca. 2 - 3 rounds per day ca. 2 rounds per day
	Yaku I.	4,930 yen	3 hours (*)	153 km	38 km/h	
Conventional Aircraft	Tanega I.	4,500 yen	35 min. (*)	130 km	223 km/h	60 x 3 rounds per day
	Yaku I.	5,100 yen	45 min. (*)	150 km	200 km/h	60 x 2 rounds per day
Passenger Rota-Ship	Tanega I.	-----	1 hour	130 km	150 km/h	120 x ?
	Yaku I.	-----	1 hour	150 km	150 km/h	120 x ?

Remarks:

(*)

Direct Route

- 1) 3 ships of 1,000-ton to 2,000-ton class.
- 2) 700 - 1,000 passengers plus 700-ton cargoes.
- 3) Annual Average of Load Factor = 40%
- 4) Cruising line service exists. Distance between the islands is 50 km.
- 5) Annual Passengers:
230 thousand: Tanega I.
150 thousand: Yaku I.

Conventional Aircraft:

- 1) YS-11: TOC = ca. 25 yen per seat per km.
- 2) Tanega Airport: 1,500 m x 45 m
Yaku Airport: 1,200 m x 45 m

Passenger Rota-Ship:

- 1) TOC = ca. 30 yen per seat per km.
- 2) Cruising line service is possible.

-Table VI-11: Okinawa - Miyako/Ishigaki Is. Line -

The line which is about 300 km to 500 km long is a field in which it is difficult for the Rota-Ship to be competitive. This line, however, can use only the YS-11 plane due to the runway limitation. Therefore, the Rota-Ship might possibly be competitive. If the Rota-Ship is scaled up, for example to a 180 to 200 passenger aircraft, so that the TOC may be reduced to the same level of the YS-11, the operation of the Rota-Ship can be said to be very promising. Considering the required time, 10 - 16 hours, by the ships in the line, the air fare at present is sufficiently competitive with sea transportation.

Table VI-11. Okinawa - Miyako/Ishigaki Is. Line.

/257

		Fare	Required Time	Line Distance	Line Speed	No. of Passengers x No. of Rounds
Ship	Miyako I.	4,600 yen	10 hours	330km	33 km/h	ca. 1,000 x 1 round/4 days
	Ishigaki I.	6,000 yen	16 hours	330km + 170km	30 km/h	ca. 1,000 x 1 round/ 4 days
Conventional Aircraft	Miyako I.	8,600 yen	1 hour (*)	280 km	280 km/h	60 x 10 rounds/day
	Ishigaki I.	11,700 yen	1 hour 20 min. (*)	400 km	300 km/h	60 x 10 rounds/day
Passenger Rota-Ship	Miyako I.	-----	ca. 2 h. (*)	280km	140 km/h	120 x ?
	Ishigaki I.	-----	ca. 2 h.	400 km	140 km/h	120 x ?

Remarks:

(*)

Ship:

Direct Flight

3,800-ton Class (1,000 passengers plus 1,200 tons of cargoes)

Okinawa - Ishigaki I. Direct Route: ca. 12 hours

Conventional Aircraft:

1) YS-11: TOC = ca. 25 yen per seat per km.

2) Miyako and Ishigaki Airports: 1,500 m x 43 m.

3) Cruising Speed of the YS-11: 475 km/h.

Passenger Rota-Ship

1) TOC = ca. 30 yen per seat per km.

2) Ishigaki Is. if possible.

(b) Possibility of Cost Reduction of Rota-Ship.

According to the conceptualizing design of the Rota-Ship, described in this report, the payload is restricted to 10-ton class (120 passengers) and the aircraft price has been calculated when ten aircraft are manufactured, as 1.5 billion yen per one aircraft.

The YS-11, the aircraft selected for comparative study in this chapter, is the model, 180 aircraft of which have been already manufactured. Likewise, if the aircraft price of the Rota-ship is calculated for the case in which 100 aircraft are manufactured, the estimate would be considerably reduced.

In addition, the Rota-Ship in this report uses the engines and the rotors of the BK-117 helicopter which is now in the development stage. These elements may be an important object for further study. These engines and rotor systems might be too sophisticated for airships. Is there any inexpensive, high-performance engine which is not as complicated as a helicopter engine and which is capable of tilting the rotor axis?

Besides, further study must be done on the mass-production affect on the aircraft parts.

Another possibility of cost reduction is the scale-up of the aircraft and passenger capacity. With a simple-minded calculation, if the passenger capacity is doubled, the operating cost may be halved.

One basic difference between LTA and HTA aircraft is the fact that there are fewer technical difficulties in building large-scale or giant LTA aircraft. Of course, this fact is a relative finding comparing LTA and HTA aircraft. However, at present, 500 to 1,000-ton class giant airships for cargo transportation are proposed in various countries in the world. Therefore, it may not be unreasonable to assume that 10-ton Rota-ship may be easily scaled up to the 20-ton class without increasing the cost significantly. /25

In the conceptualizing design of the Rota-Ship for cargo transportation, the price of a 30-ton payload (about 360 passenger) Rota-Ship is estimated to be 3.3 billion yen per one aircraft when ten aircraft are manufactured.

However, whether the aircraft should have a capacity of 120, 200, or 360 passengers, depends totally on the passenger demand.

In this regard, "Circumstances Surrounding Civil Aircraft Industries and Their Trends" (published by the Japan Society for the Promotion of Machinery, March 1976) pointed out that "A peak of the trend of cost reduction by scaling up will be soon seen. In the near future, it will become very difficult to reduce the effective cost by the scale up." This statement, however, was directed to the HTA aircraft industries.

Concerning the LTA aircraft, "a peak of the trend of cost reduction by scaling up" has not been predicted yet. It should rather be pointed out that the future possibilities are still open.

(c) Noise Problem.

The noise of the aircraft is determined by the correlation of the engine output and the take-off and landing mode. One target of the STOL aircraft which is now part of a development plan in Japan is the low noise property comparable to the YS-11. The engine output and the take-off/landing mode of the Rota-ship are compared with those of the YS-11 in the following:

Rota-Ship: 600 HP x 2 x 4 (units) = 4,800 HP, VTOL (within 500 m)
YS-11: 3,000 HP x 2 = 6,000 HP, 1,200 m Runway

Since the engine output is about 4/5 of that of the YS-11 and the take-off/landing mode is almost VTOL, the absolute level of the noise and the area of noise pollution will be surely reduced by the Rota-Ship.

(d) Problem of Fuel Consumption.

As shown in Fig. IV-22, the fuel consumption of the Rota-Ship is about 5/7 of that of the YS-11. Therefore, although the aircraft price is high and the initial investment is expensive, the fuel cost can be expected to be low.

(e) Marketability in Oversea Markets.

The aircraft which are desired around 1990 and their change in demands as a world-wide trend are shown in Fig. VI-2. As seen from this figure, the most desired aircraft is the so-called wide-body middle/short-distance jet plane. In short or middle distance airlines, the high-speed provided by jet planes can hardly be expected. The basis of the demand for jet planes resides in the wide body which can carry a large capacity and the jet engine whose large output can support this body. Thus, it can be said that the essential demand is for large-size (wide body) short-distance aircraft.

The Rota-Ship has the basic characteristics which can satisfy these requirements.

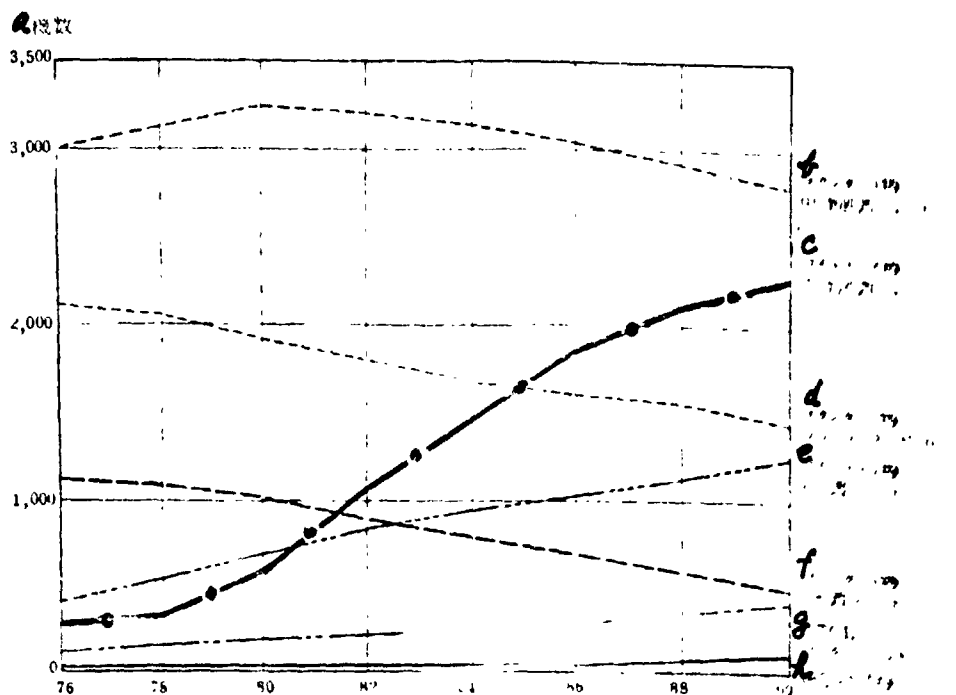

Fig. VI-2. World-Wide Prediction of Future Demand for Aircraft.
 (Cited from "Circumstances Surrounding Civil Aircraft Industries and Their Trends," published by the Japan Society for the Promotion of Machinery, March 1976)

Key to Fig. VI-2.

- a: Number of Aircraft.
- b: Standard Middle/Short-Distance Jet Planes
- c: Wide-Body Middle/Short Distance Jet Planes
- d: Standard Propeller/Turboprop Planes
- e: Wide-Body Long-Distance Jet Planes
- f: Standard Long-Distance Jet Planes
- g: STOL Jet Planes
- h: Super Sonic Passenger Planes

The growth rates of air transportation are the highest in the Middle/Near East and the Asia/Oceania Areas. According to "Circumstances Surrounding Civil Aircraft Industries and Their Trends," which was cited previously, the growth of the air transportation demand in 15 years from 1975 is predicted as follows:

ORIGINAL PAGE IS
 OF POOR QUALITY

1. Middle/Near East	11.2%
2. Asia/Oceania	9.2%
3. Canada	8.7%
4. Africa	7.7%
5. Latin America	7.4%
6. Europe	7.0%
7. U.S.A.	5.8%

Among Asian countries, the Philippines and Indonesia have numerous islands and straits and their geographical character is similar to that of Japan.

Therefore, if an aircraft model is adequate for domestic lines in Japan, it may be introduced to the markets in those countries without difficulty.

(f) Influences to Fields outside Passenger Transportation.

/260

As mentioned earlier in this report, the predicted influence by the development of the Rota-Ship includes heavy cargo air transportation. In this field, it may be said that conventional HTA aircraft cannot satisfy the demand any longer. More specifically, the present demand of the heavy cargo air transportation requires the augmented payload of helicopters. If helicopters have already reached the limitation of their ability to carry heavy cargoes, there is no other air transportation means which can carry the heavy cargoes (20 to 100 tons) and which can satisfy social demands, other than hybrid LTA aircraft. Thus, the Rota-Ship possesses a real potential for becoming a transportation means which has no alternative technique. However, it should be noted that the Rota-Ship is only one of the hybrid LTA aircraft which may be applied to this field of heavy cargo transportation and that perhaps another model of hybrid LTA aircraft with higher performance properties will be developed.

Finally, the author wishes to point out that hybrid LTA aircraft have a basic character which can be applied to a wide range of fields including passenger air transportation and heavy cargo air transportation.

Supplementary Remark: According to a recent report on wind tunnel experiment data on Helistat by NASA, a stability/control simulation program shows that the final side displacement is about 17 cm (0.55 ft) in the hovering response to a sharp edge sudden side wind of 16 m/s (50 ft/s).

VI-1-3. Hybrid Airships for Heavy Cargo Transport.

40-ton payload and 70-ton payload Skycranes and 30-ton payload Rota-Ships are studied in this section. Refer to Tables VI-12 and VI-13 for the comparison of specifications, performance properties and economical efficiency.

(a) Rental Charges of Skycrane and Rota-Ship.

Table VI-13 shows the rental charges (per hour) of the Skycrane and the Rota-Ship which are calculated based on those by the conventional largest-size helicopters. The actual rental charges may be much less than the estimates in this table. The scale of 30-ton or 70-ton payload Rota-Ships is about 10 to 20 times as great as the KV-107 helicopter. Therefore, the fuel cost will naturally be reduced by mass purchase of the fuel. Helicopters such as the KV-107 are operated on an irregular transportation basis. However, the Skycrane or the Rota-Ship is designed for the exclusive use of transporting equipment in dam construction or the like. Consequently, the target of the annual paid flight time has been set at around 1,000 hours. Nevertheless, the rental charge, 6 million yen per hour or 4.24 million yen per hour, of the Skycrane and the Rota-Ship, is directly calculated based on the operations of conventional helicopters.

Thus, this estimate has been made in a way in which the cost of a dump truck used in dam construction in deep mountains is calculated, based on the calculation base for taxis in the cities. The results shown in Table VI-13, however, are only numbers which result from a certain standard. The author feels that these numbers are almost the upper limits of the possible estimates. Nevertheless, one cannot expect that these numbers may be halved according to another estimate.

Table VI-12

/261

SKYCRANE				ROTA-SHIP (CARGO)		
Gross Weight	40-Ton Payload 75 tons	70-Ton Payload 123 tons	Remarks	30-Ton Payload 68 tons	Remarks	
Payload (including Fuel)	44 tons (Fuel: 4 tons)	74 tons (Fuel: 7 tons)		36.7 tons (Fuel: 6.7 tons)		
Cruising Speed	50 + 18.5 km/h	50 + 18.5 km/h		100 km/h		
Distance of Cruise	150 km plus 30 min. of Hovering (*)	150 km plus 30 min. of Hovering (*)	Ascent Limit: 1,000 m	330 km	Ascent Limit: 2,000 m	
Size	Balloon Radius	25 m	29 m		90 m (total Length)	
	Wing Radius	46 m	49 m	(**)	30 m (Total Width)	
	Rotation of wing Balloon	1.0 rad/s (10 r.p.m.)	1.25 r.p.s.		-----	
	Gas Volume	ca. 60,000 m ³	ca. 100,000 m ³		36,000 m ³	
Propulsion	Engine	4 x 1,800 HP	4 x 2,800 HP		8 x 1,400 HP	Rotor System of KV-107 Helicopter
	Propeller	4-Blade (D: 6m)	4-Blade (D: 6m)		3-Blade (D:15m)	

--continued--

No. of Crew Members	5	5		4	
Price per one Aircraft	3.1 billion yen	4.6 billion yen	(***)	3.3 billion yen (4.1 billion yen)	(****)

Supplementary Remarks:

(*) Winds of 10 knots (5 m/s) are considered.

(**) The distance from the center of the balloon to the wing tips.

(***) When ten aircraft are manufactured.

(****) When ten aircraft are manufactured.

The amount in parenthesis is that in the case where one aircraft is manufactured.

Table VI-13.

Model	Rental	Payload	Duration of Cruise	Distance of Cruise	Speed
Skycrane	per Hour 600 million yen	70 tons	3 hours	150 km	50 km/h
Rota-Ship	424 million yen	30 tons	3 hours	333 km	110 km/h
KV-107	74 million yen	3.4 tons	3 hours	700 km	236 km/h

In the following, the performance properties of each aircraft will be described.

/262

(b) Performance of Skycrane.

The ascent limit, 1,000 m, of the Skycrane is unsatisfactory in connection with its considered uses. Among planned hydroelectrical power plants, pumped-storage plants will be constructed at a high altitude, possibly up to 2,000 m.

In this study, the basic question concerning the Skycrane was whether an object with the shape of the Skycrane can actually fly or not. Therefore, sufficient study has not been made concerning the performance of the Skycrane when loading and unloading heavy cargoes and the accommodation of the Skycrane on the ground.

Hence, more detailed studies must be done with further conceptualizing designs in order to make the idea more concrete.

The results shown in this report must be considered as the first representation of an image of a flying object which may be a tool for transporting about 70-ton payload.

(c) Performance of Rota-Ship (for Heavy-Cargo Transportation).

The cruising speed, 100 km/h, of the Rota-Ship for heavy cargo transportation is probably more than the required performance property, compared with its uses. As seen in the report made by the Asahi Helicopter Company, when a helicopter transports a suspended cargo, the operational speed is at most 30 km/h. When an aircraft carries a suspended cargo outside its body, it cannot fly at high speed. Therefore, the speed of 100 km/h is not adequate for heavy cargo transportation means such as the Rota-Ship. This inadequacy results from the fact that the conceptualizing design of the rota-ship was made under the assumption that it uses engines and rotor systems of a large-size helicopter which is available in the Japanese market. The selected rotor and engines cost 400 million yen per unit and 1.6 billion yen per unit, respectively. These elements must be replaced in the course of further development of the practical uses of the aircraft.

In addition, for a flying object which travels at a low speed, 30 to 50 km/h in deep valleys or mountains the fineness ratio of the airship portion had better be chosen so that the body is almost a ball and is more compact.

(d) Demand in the Market.

Perhaps it is too early to present an estimate of the demand in the market in terms of yen-value at the present stage of study. Among the committee members responsible for this chapter, there was a strong feeling that such an estimate should not be made at the present stage.

However, anticipating heavy criticism, the author dares to present a computed result for the following two reasons: First, a rough estimate of the scale of the market may be necessary. Second, for the next stage of the study, it may be useful to present a methodology which is prepared for the further critics.

It should be repeatedly pointed out, however, that the following /263 estimates are based on a set of assumptions whose validity has not been proven, and that there may be many errors in the data used.

The objects of the survey are limited to the electric power industries. They are the fields of inland construction of power plants, power transmission lines and power substations.

Of course, there is demand for heavy cargo air transportation in the industrial fields outside these areas in Japan. However, in this section, such demand is excluded.

In addition, in various countries in the world, power plants are being constructed by Japanese or foreign companies. This survey, however, excludes such oversea markets.

Table VI-4. lists the possible cost reduction by the potential air transportation means which can carry cargoes from 20 tons to 100 tons in construction works concerning electric power industries in Japan.

According to this estimation, the demand is anticipated to be 11 billion yen per year and 110 billion yen for ten years.

The amount of the construction works and the total construction cost are based on the Electric Power Development Plan and are the most certain values.

The objects of cost reduction are classified into two categories: (1) cost reduction of civil engineering works due to the reduction of construction period, and (2) reduction of transportation cost.

It is estimated that the cost of civil engineering works occupies about 50% of the total construction cost on average including pumped-storage, common hydroelectric and geothermal power plants. This fraction, however, varies according to the type of the construction. For example, it is estimated to be more than 50% in common hydroelectric power plant constructions.

(1) Cost Reduction of Civil Engineering Works Due to Reduction of Construction Period.

The estimate of this cost reduction is based on the following basis.

In a case of constructing a power station with 50 billion yen of the cost of civil engineering works, the construction period is estimated to be 5 years (60 months) and 6 months are estimated to be consumed for the civil engineering works including construction of tunnels and bridges. If civil engineering equipment can be carried to the mountain side by air, the work can be started from the both sides. Assuming that the construction period is thus reduced by 3 months and that the interest and the expenses are 7% and 5% respectively, (in total 12%),

$$\begin{aligned} 50 \text{ billion yen} \times 12\% \times (3/60) &= 50 \text{ billion yen} \times 0.6 \\ &= 300 \text{ million yen} \end{aligned}$$

can be saved. It is for this reason that cost of the civil engineering works is estimated to be reduced by 0.6%.

Table VI-14. Estimated Annual Amount Saved

/264

Construction Objects and Total Construction Cost	Costs Which can be Saved	Saved Amount by LTA Aircraft	Estimated Total Amount Saved	Payload Required for LTA
(1) Pumped-Storage Power Plant 110 billion yen 1,200,000 kW	(a) Civil Engineering Works: 50% of the total cost 55 billion yen (b) Heavy Cargo Transportation Cost 2% of the total cost 2.2 billion yen	0.6% 330 million yen 40% 900 million yen	ca. 1.2 billion yen	50 tons (most desired)
(2) Common Hydroelectric Power Plant 150-250 Billion yen 45,000 - 80,000 kW	(a) Civil Engineering Works: 50% of the total cost 75 billion yen (b) Heavy Cargo Transportation Cost 2% of the total cost 3 - 5 billion yen	0.6% 450 million yen 40% 1.2 - 2 billion yen	ca. 1.7 billion yen	50 tons (most desired)
(3) Geothermal Power Plant ? billion years 300,000 - 500,000 kW	(a) Civil Engineering Works: 50 % of the total cost ? billion yen (b) Heavy Cargo Transportation Cost 2% of the total cost 2.5 billion yen	3% ? billion yen 40% 1 billion yen	1.1 billion yen	50 tons (mostly desired)

-continued-

(4) Trans- mission Lines and Iron Towers 700 billion yen	Transporta- tion Cost of Members 6% of the total cost 42 billion yen	10% 4.2 billion yen	4.2 billion yen	20 tons is sufficient (*)
(5) Power Substations Heavy Cargoes: 390 billion yen Total: 700 billion yen	Heavy Equipment Transporta- tion 13% of the total cost In Total: 390 billion yen x 13% = 50.7 bil- lion yen	5% 2.8 billion yen	2.8 billion yen	100 tons is desired probably.

Remark: (*) The maximum payload of the conventional helicopters is 3.3 tons and they cost 740 thousand yen per hour.

In this case, the following question has been raised: Can the total construction, 50 billion yen, be borrowed only for the initial construction works such as tunnel or road constructions? Some correction must be made through the future course of the study. In obtaining the estimates represented in this section, the estimating method mentioned above has been accepted as a tentative calculation.

/265

(2) Since the members who were engaged in the survey concerning this section are actually in charge of management of the heavy cargo transportation in power plant construction, the estimates of heavy cargo transportation cost can be thought to be most accurate.

The following is cost analysis of an example, 0 Pumped-Storage Power Station which is now being constructed in the deep mountains in Kii Peninsula:

*Station Scale:	ca. 1,200,000 kW
*Total Construction Cost:	78.8 billion yen
*Transportation Distance around the Construction Site:	57 km
*Total Transportation of Electric Power Generating Equipment:	16,000 tons (100%)

*Cargoes Heavier Than
20 tons (Object Limited
by Vehicle Weight
Limitation Rule):

112 packages: 20 tons or lighter
80 packages: 30 tons or lighter
122 packages: 40 tons or lighter
18 packages: 70 tons or lighter

*Direct Transportation
Cost:
(From Factories in
Tokyo - Yokohama
Area to Construction
Site)

50,000 -100,000 yen/ton

(x 9,500 tons = 480 - 950 million
yen)

*Indirect Trans-
portation Cost:

Total: ca. 1.1 billion yen
Reinforcement of Bridges:
230 million yen
Detour Routes (8 km):
300 million yen
Compensation for Prefecture
Road:
500 million yen
Reinforcement Works for
Underground Equipment:
70 million yen

*Total Transportation
Cost, the Sum of the
Direct and the Indir-
ect Transportation
Costs:

ca. 1.6 billion yen to
2.0 billion yen

*Fraction of Heavy Cargo
Transportation Cost in
the Total Construction
Cost of Power Station: 1.6 billion yen/78.8 billion yen
to
2.0 billion yen/78.8 billion yen
= ca.2 %

According to the above statistics, it was concluded that the fraction of heavy cargo transportation in the total construction cost is estimated at about 2%.

The judgment that the cost of heavy cargo transportation can be reduced by 40% by the LTA (or 60% cannot be reduced) was made by the committee members in charge of this section, taking a glance at the conceptualizing designs of the Skycrane and the Rota-Ship for heavy cargo transportation.

The number, 40% should therefore be accepted as a variable with substantial uncertain factors. Rather, this number can be interpreted as an index showing the lower limit which enables a transportation tool to be feasible in the construction sites. /26c

(3) The estimates concerning with the power transmission line construction are based on an example, S. Line Construction Plan (T Electricity Company) which is now being carried out.

The outline of this construction is seen in the following:

- *Total Line Length: 126 km
- *Power Transmission Capacity: 10,000,000 kW
500 kV
- *Total Construction Cost: 45 billion yen excluding land use costs.
- *Construction Period: 3 years
- *Total Weight of Construction Materials: 216,000 tons
- *Transportation Means:

	Weight	Transportation Cost	Unit Cost
Helicopter	36,000 tons (17%)	1,800 million yen (67%)	49,000 yen/ton
Freight-Carrying Cable	102,000 tons (47%)	600 million yen (22%)	1,700 - 4,000 yen, ton
Truck	78,000 tons (36%)	300 million yen (11%)	4,000 yen/ton

* This construction plan is one of the largest scale among power transmission line constructions in Japan. However, the fraction of the helicopter uses (measured by the transported weight) in this construction works seems to be very low. This fraction is expected to be about 30 - 40 % in the future.

* The fraction of the material transportation cost in the total construction cost is:

$$\frac{2.7 \text{ billion yen}}{45.0 \text{ billion yen}} = \text{ca. } 6\%$$

*Helicopters Presently Used in Power Transmission Construction Works:

	Payload	Charter Fare	Available No. of Units
Bell 204B	0.8 - 1.2 tons	414,000 yen/h	14
Bell 214B	2.5 - 3.3 tons	740,000 yen/h	2
Vertol KV107	2.5 tons	688,000 yen/h	3
Others	-----	-----	9
Total			28

*Annual Weight Transported by Helicopter (Tokyo Electricity Company):

80,000 tons - 100,000 tons.

*Annual Weight Transported by Helicopters (10 Electricity Companies in Japan):
about 250,000 tons

Based on the data above, the fraction of material transportation cost in the total construction cost is estimated to be 6%.

A question is: What percentage of this transportation cost can be saved by using a new air transportation means (hybrid airship)? In this study, this percentage has been selected to be 10%. Unfortunately, /267 there is no definite ground for this estimate. However, considering the time of introducing the aircraft with the payload which is about ten times as great as that of the presently used helicopters, 10%, or 4.2 billion yen, might be an under-estimation. Anyhow, in this report, 10% has been selected for a tentative calculation.

(§) In case of construction of power substations, the estimation was done also based on the data from the actual constructions. (The detailed description is omitted here.) Unfortunately, the resultant estimate, 5% and 2.8 billion yen, has no definite ground.

When comparing transmission line tower construction and power substation construction, the former may be carried out by only using transportation means of 20-ton payload with less difficulty. Due to many heavy equipment installed in a power substation, transportation tools which have the payload of 100-ton-class are hoped for in its construction.

In each case, no definite ground for each estimate has been shown in the stage of this survey study. More reliable estimates are left to the further, more elaborate studies.

Nevertheless, the members who are in charge of this section feel that there will be a total annual demand which is greater than 10 billion yen. This conclusion is rather intuitive based on the experiences which the committee members have accumulated in the past works in the relevant fields, than a result obtained from a statistical analysis of the data.

VI-2. Comprehensive Evaluation of LTA Aircraft as a Whole.

The committee members of this survey study have been studying technical possibilities of LTA aircraft, market conditions for them, their social impacts, etc., for the past three years. The objects of the study were:

- (1) Small-Size Non-Rigid Airship.....Survey on Presently Used Aircraft.
- (2) Small-Size Rigid Airship.....Conceptualizing Design
- (3) Small-Size Semi-Rigid Airship.....Conceptualizing Design
- (4) Large-Size Rigid Airship
- (5) Balloon System for Cargo Handling at Harbor.....Conceptualizing Design
- (6) Balloon System for Observation and Monitoring.....Conceptualizing Design
- (7) Hybrid Airship (for Passenger).....Conceptualizing Design
- (8) Hybrid Airship (for Heavy - Cargo Transportation).....Conceptualizing Design
- (9) Hybrid Airship (Rota-Ship for Passenger Transportation).....Conceptualizing Design
- (10) Hybrid Airship (Rota-Ship for Heavy-Cargo Transportation and Skycrane).....Conceptualizing Design
- (11) Hybrid Airship (Megalifter Type)
- (12) Auto-Piloting System for Suspended Gondola

Table VI-15 shows the technical possibilities (the circumstance of the "seeds"), the market conditions (the circumstance of the "needs") and the environmental conditions of a whole society for each of the above objects of this study.

After such a discussion and after having investigated the development stages in foreign countries (Cf. Oversea Reference Material I), it was concluded that the objects are classified into the following groups which are ordered by their priority status as objects which Japan should deal with.

- 1st Group: (7), (8-i) and (8-ii)
 2nd Group: (1), (5), (6) and (10)
 3rd Group: (9) and (4)

It should be noted that the development of (1), (9), (4) and (10) would be largely done in the course of the development of the objects in the first group. Also, the objects (1) and (6) will use a similar hull shape with different propulsion means and may be included in one development plan.

The ground for the fact that the first group includes only (7) and (8) is not very firm. It is mainly based on the fact that the Helistat type aircraft are ahead of other type of LTA aircraft in their development stages in France and the U.S.A. LTA aircraft other than the Helistat type aircraft will change their status in the course of the future detailed studies.

Nevertheless, despite of many uncertainties in the predictions, it is concluded that, if overall study and development of LTA aircraft are desired, the promotion of the development of the LTA aircraft in the first group is the best in terms of preferable impacts to the development of all useful LTA aircraft.

Table VI-15. Comprehensive Evaluation of LTA Aircraft as a Whole./269

(1) Small-Size Non-Rigid Airship.

Technical Possibility: Is sufficiently technically feasible.
 There is no significant technical influence to other fields.
 Is feasible also economically.

Market Condition: Considerable demand exists in the fields of monitoring, observation, advertisement, sight-seeing, etc. Also, the demand in the markets of ocean survey and surveillance will grow significantly.

Problems and Remarks: *The present task is to reinforce the operating organization and systems.
 *Poor maneuvering performances are the biggest problem to be questioned.
 *At present, several aircraft are being used in foreign countries. In Japan, it was used twice in the past.

(2) Small-Size Rigid Airship.

Technical Possibility: A conceptualizing design was done.
 Is technically feasible.
 However, the economic efficiency is questionable.

Market Condition: Same as (1)

Problems and Remarks:

*It is important as an experimental aircraft in preparation for the development of large-size rigid airships.

(3) Small-Size Semi-Rigid Airship.

Technical Possibility:

A conceptualizing design was done. Is technically feasible. However, the economic efficiency is questionable.

Market Condition:

Same as (1)

(4) Large-Size Rigid Airship.

Technical Possibility:

No conceptualizing design was done. Perhaps economically efficient. The detailed discussions on the technology are left to further studies.

Market Condition:

In the future era when large amount of air cargo are carried by regularly operated aircraft, this aircraft may become very important.

Social Influences:

Energy conserving
Low noise property.
Requires less airport land.

Problems and Remarks:

*In "View on Aircraft in the 21st century," which has been recently published by NASA, one of the three realizable important targets is a cargo transportation aircraft of 1,000-ton class. (The other two are super sonic aircraft for international lines and VTOL aircraft for connecting cities.)
*The technique may be interconnected with that of the Megalifter.
*If a nuclear engine is developed in the future, this aircraft may attract much attention.

(5) Balloon System for Cargo Handling at Harbor.

Technical Possibility:

Is technically feasible.
A conceptualizing design was done. Is economically efficient.

Market Condition:

There are promising markets in developing countries.
The domestic markets cannot be hoped for much.

Problems and Remarks:

*A survey study is being done by the Japan Society of Aeronautics and Space Industries.
*The one for forestry use is now in the stage of trial manufacturing in a plan by the Ministry of Agriculture and Forestry.
*The balloon is ball-shaped or tear-drop shaped.

(6) Balloon System for Observation and Monitoring.

Technical Possibility: Is sufficiently technically feasible.
More advanced techniques are now sought.
Is economically efficient.

Market Condition: There are promising domestic markets for
marine survey and pollution monitoring.

Problems and Remarks: *The balloon may probably be stream-
line-shaped.
*A study is being done by the Japan
Society of Aeronautics and Space In-
dustries.

(7) Hybrid Airship (Passenger Rota-Ship).

Technical Possibility: A conceptual design was done.
The technical possibility is very sure.
The economical efficiency will soon
enter the region where it is competitive.
There are expected many influences to
other fields.

Market Condition: Is promising in short-distance airlines
in Japan.
Also, in island countries around Japan.
Is also promising as short-distance
mass-transportation aircraft in the
world's markets.

Social Influences: Energy conserving.
Low Noise property.
Requires less airport land.

Problems and Remarks: *One of the three big targets described
in "View of aircraft in the 21st century"
by NASA is VTOL aircraft for connecting
cities.
*Some problems such as the ability of
regular operation in airline are left
to further studies.

(8-i) Hybrid Airship (Heavy-Cargo Rota-Ship).

Technical Possibility: A conceptualizing design was done.
The technical possibility is very sure.
The economic efficiency is slightly
short.
There are expected many influences to
other fields.

Market Condition: There are big markets in Japan.
There are no alternative means.
If being successful, the aircraft will
be desired from the oversea markets.

Social Influences: Is deeply connected with the government's energy development plans. May prevent pollution, environment destroying, etc. in connection with road constructions.

Problems and Remarks: *Contains a possibility of inducing a kind of "technological innovation."
*The development is greatly desired by electric power and heavy equipment industries.

(8-ii) Hybrid Airship (For Heavy-Cargo Transportation): Skycrane.

Technical Possibility: A conceptualizing design was done. The technical possibility contains many uncertain elements. Economical Efficiency is expected.

Market Condition: Same as (8-i)

Social Influences: Same as (8-i)

Problems and Remarks: Same as (8-i)

(9) Hybrid Airship (Megalifter Type).

Technical Possibility: The detailed technical studies are left to the future development. Economic efficiency has not been confirmed

Market Condition: Same as (4)

Social Influences: Similar to (4)

Problems and Remarks: *The development is now at the stage of basic technological study.
*If a nuclear engine is developed, this aircraft will attract much attention.

(10) Auto-Piloting Means for Suspended Gondola.

Technical Possibility: Is technically feasible. Economic efficiency has not been confirmed.

Problems and Remarks: *This device is used in combination with the aircraft (1) through (9).