

## **General Disclaimer**

### **One or more of the Following Statements may affect this Document**

- This document has been reproduced from the best copy furnished by the organizational source. It is being released in the interest of making available as much information as possible.
- This document may contain data, which exceeds the sheet parameters. It was furnished in this condition by the organizational source and is the best copy available.
- This document may contain tone-on-tone or color graphs, charts and/or pictures, which have been reproduced in black and white.
- This document is paginated as submitted by the original source.
- Portions of this document are not fully legible due to the historical nature of some of the material. However, it is the best reproduction available from the original submission.

(NASA-CR-145382-2) ADVANCED COMPOSITES WING  
STUDY PROGRAM, VOLUME 2 Final Report  
(Boeing Commercial Airplane Co., Seattle)  
119 p HC A06/MF A01 CSCI 11D

N78-32186

G3/24 Unclas  
31583

NASA Contractor Report 145382-2

# Advanced Composites Wing Study Program Volume 2-Final Report

S.T. Harvey and G.L. Michaelson

BOEING COMMERCIAL AIRPLANE COMPANY  
P.O. BOX 3707  
SEATTLE, WASHINGTON 98124

CONTRACT NAS1-15003  
AUGUST 1, 1978

**NASA**

National Aeronautics and  
Space Administration

Langley Research Center  
Hampton, Virginia 23665



TABLE OF CONTENTS

SECTION		PAGE
1.0	SUMMARY	1
2.0	INTRODUCTION	5
	2.1	BENEFITS 5
	2.2	REPORT/CONTRACT INTERFACE 7
3.0	STUDY PROGRAM OVERVIEW	11
	3.1	STRUCTURAL CONCEPTS STUDIES 13
	3.1.1	Design 13
	3.1.2	Baseline Design 13
	3.1.3	Conceptual Design 14
	3.1.4	Advanced Composites Design- Outboard Wing Box 25
	3.1.5	Advanced Composites Design- Wing Center Section 30
	3.1.6	Design and Weight Analysis 34
	3.1.7	Design Assessment 36
	3.2	TECHNOLOGY ASSESSMENT 41
	3.2.1	NASA/ACEE Program Contributions 43
	3.2.2	DOD Contributions 44
	3.2.3	Technology Assessment Summary 45
4.0	RECOMMENDED PROGRAM	47
	4.1	TECHNOLOGY DEVELOPMENT 48
	4.1.1	Damage Tolerance 49
	4.1.2	Durability/Repeated Loads 52
	4.1.3	Electromagnetics Technology- Lightning Protection 54
	4.1.4	Environmental Effects 57
	4.1.5	Material Improvement 60
	4.1.6	Other Concerns 62
	4.2	PRODUCTION CAPABILITY DEVELOPMENT 65
	4.2.1	Production Plan 65
	4.2.2	Tooling/Facility Plan 75
	4.2.3	Production Development Plan 77

Boeing Commercial  
Airplane Company  
Contract NAS1-15003

	4.3	INTEGRATION AND VALIDATION HARDWARE DEVELOPMENT OPTIONS	87
	4.3.1	Description	89
	4.3.2	Program Option Evaluation	91
	4.3.3	Summary and Recommendation	92
	4.3.4	Option C	97
	4.4	RECOMMENDED PROGRAM SCHEDULE	107
5.0		AIRLINE COORDINATION	109
6.0		FAA CERTIFICATION	111
7.0		CONCLUSIONS	113

LIST OF FIGURES AND TABLES

FIGURE		PAGE
2-1	Benefits Derived from the Use of Advanced Composites	6
2-2	Weight Reduction and Fuel Savings Using Advanced Composites	6
2-3	Advanced Composites Wing Study Organization	8
3-1	Baseline Airplane	15
3-2	Baseline Metal Wing	15
3-3	NASA Wing Study Advanced Composites Wing Concept Layout	17
3-4	NASA Wing Study Advanced Composites Wing Concept Layout--Center Section	31
3-5	Wing Box Upper Panel Design Loads Stiffnesses	35
3-6	Wing Box Lower Panel Design Loads Stiffnesses	35
3-7	Wing Box Upper Panel Weights	37
3-8	Wing Box Lower Panel Weights	37
4-1	Development of Environmental Effects Technology	59
4-2	Spar Detail Fabrication Flow	68
4-3	Production Quality Assurance	68
4-4	Rib Fabrication Flow	70
4-5	Mechanized Kitting	71
4-6	Sandwich Pultrusion	73
4-7	Automated Layup Machine	74
4-8	Automated Assembly Machine	76
4-9	Production Fabrication Facility	78
4-10	Production Assembly Facility	78
4-11	Process Development Schedule	80
4-12	Process Integration and Validation	88
4-13	Option A--Ground Test 737 Left-Hand Wing Box	90

Boeing Commercial  
Airplane Company  
Contract NAS1-15003

4-14	Option B--707 Outboard Wing Flight Service	90
4-15	Option C--737 Wing Box	90
4-16	Option D--727 Wing Box	90
4-17	Option C Schedule	98
4-18	Structural Development Tests	101
4-19	System Development Tests	102
4-20	Major Structural Tests	105
4-21	Major Structural and System Tests	105
4-22	Recommended Program Schedule-Option C	108

		PAGE
3-1	Design/Producibility Evaluation--General Configuration (Planform)	20
3-2	Design/Producibility Evaluation--General Configuration (Cross Section)	21
3-3	Design/Producibility Evaluation--Substructure Configuration	22
3-4	Design/Producibility Evaluation--Skin Panel Configuration	23
3-5	Wing Box Weight Comparison Summary	38
4-1	Production Capability Assessment Sheet	82
4-2	Technical Evaluation	93
4-3	Manufacturing Evaluation	94
4-4	Airline Acceptance Evaluation (1985)	95
4-5	Option Evaluation Summary	96
4-6	Production Capability Integration and Validation Process--Option C	99

SECTION 1.0

SUMMARY

The "Study on Utilization of Advanced Composites in Commercial Aircraft Wing Structures" was conducted as a part of the NASA Aircraft Energy Efficiency (ACEE) Program to establish, by the mid-1980s, the technology for the design of a subsonic commercial transport aircraft leading to a 40% fuel savings. The study objective was to develop a plan to define the effort needed to support a production commitment for the extensive use of composite materials in wings of new generation aircraft that will enter service in the 1985-1990 time period. This report presents The Boeing Company's approach for achieving production readiness for advanced composites wing structure.

Identification and analysis of what was needed to meet the above plan requirements resulted in a program plan consisting of three key development areas:

- Technology development
- Production capability development
- Integration and validation by designing, building, and testing major development hardware.

These efforts need to be conducted in parallel to be most effective and to ensure readiness for a production commitment in 1985.

Boeing Commercial  
Airplane Company  
Contract NAS1-15003

Technology development needs were identified through a comprehensive examination of engineering technology disciplines to assess the current state-of-the-art and known plans for future technology development. From this in-depth investigation, the following areas were identified as needing major data development, and are the primary items addressed in the technology development portion of the recommended program.

- Damage tolerance
- Durability/repeated loads
- Electromagnetic effects
- Environmental effects
- Material improvement

Production capability needs were defined, following a series of trade studies conducted to determine the most cost-effective fabrication and assembly processes for wing box spars, ribs, and skin panels. It was determined that mechanized production methods must be developed if advanced composites structure is to be cost-competitive with metal structure. Specific areas identified for development needed to support the production capability development are listed below, the second major portion of the recommended program.

1. Quality Assurance

- Material acceptance improvements
- In-process adaptive controls
- Skin panel cure monitoring
- Automated nondestructive inspection methods

2. Fabrication Processes

- Filament winding long structural shapes
- Automated layup machine for larger panels
- Tapering thick sandwich pultrusion development
- Elastomeric die molding structural components
- Automated prepreg cutting center
- Improved prepreg materials

3. Assembly Methods

- Hole preparation
- Fastening systems
- Sealant and sealant application
- Automated assembly machine for fastened components

Integration and validation of the technology and production capability development required design, fabrication, testing, and certification of a wing box structure. Four wing box options, representing different levels of cost and risk, were developed and evaluated.

Integration and validation Option A consists of the design, fabrication, and full-scale ground test of a 737 left-hand outboard wing box. Option B adds to Option A a flight test of a 707-320 left-hand outboard wing box. Option C uses two 737 wing center sections and left-hand wing boxes for ground testing, plus a "tip-to-tip" 737 wing box and center section for flight test. Option D differs from Option C, in that a 727 is used in place of a 737 airplane.

Boeing Commercial  
Airplane Company  
Contract NAS1-15003

Integration and validation of Option C, together with the technology and production capability development efforts, is the recommended program. It is a low-risk program that addresses all major technology and production capability development, FAA certification, and cost data needs in sufficient depth to reach the production commitment readiness goal in 1985. Production cost projections will be based on actual fabrication, assembly, and installation costs for flight-worthy wing structure. Flight testing ensures that certification methods are established, and will enhance operator confidence in the use of advanced composites in highly loaded primary structure.

It is envisaged that the tip-to-tip advanced composites wing will be applied to a dedicated freighter aircraft or a military T-43 (737) navigational trainer. Option D (727 wing) would be substituted if a suitable 737 aircraft could not be obtained.

The Boeing Company believes that adoption of the recommended program would be a logical and timely follow-on to current Government/industry advanced composites effort. It would contribute significantly to the NASA/ACEE Program objective for commercial transport aircraft designs requiring 40% less fuel.

Boeing Commercial  
Airplane Company  
Contract NAS1-15003

## SECTION 2.0

### INTRODUCTION

#### 2.1 BENEFITS

NASA, the airlines, and the airplane manufacturers have a common goal, to achieve energy efficient airplanes that will help preserve petroleum reserves and provide safe, reliable, quiet transportation at reasonable cost (Figure 2-1). The advanced composites structure element of NASA's Aircraft Energy Efficient Program involves the commercial jet transport industry in the effort to save fuel by reducing airplane structural weight. Weight reduction has always been a method of improving airplane efficiency, but two recent developments have emphasized its importance. First is the sudden and significant increase in fuel prices from a relatively low and stable base. Second, the maturity of advanced composites materials has reached the point where they must be considered a practical alternative lightweight material for future aerospace structures. With the structural weight of commercial airplanes reduced, they can carry designed payloads at reduced fuel consumption.

Studies have shown that, with the extensive use of advanced composites, and where the structure has been resized, a fuel savings of 12%-15% over metal designs can be achieved (Figure 2-2). This fuel saving analysis is based upon a comparison of airplanes with the same payload and engine technology with a single variable; i.e., the metal airplane was redesigned with the extensive use of advanced composites in areas of the empennage, wing, and fuselage where the material substitution would be practical.

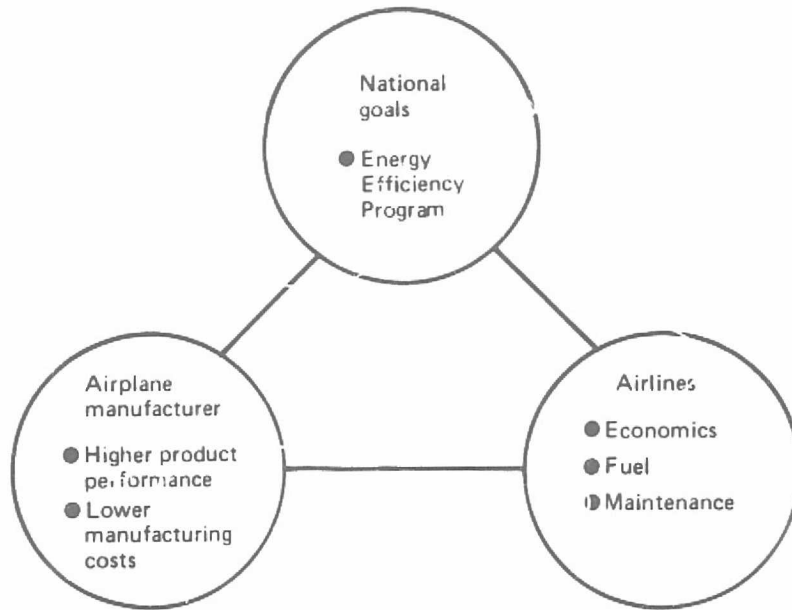

Figure 2-1 Benefits Derived from the Use of Advanced Composites

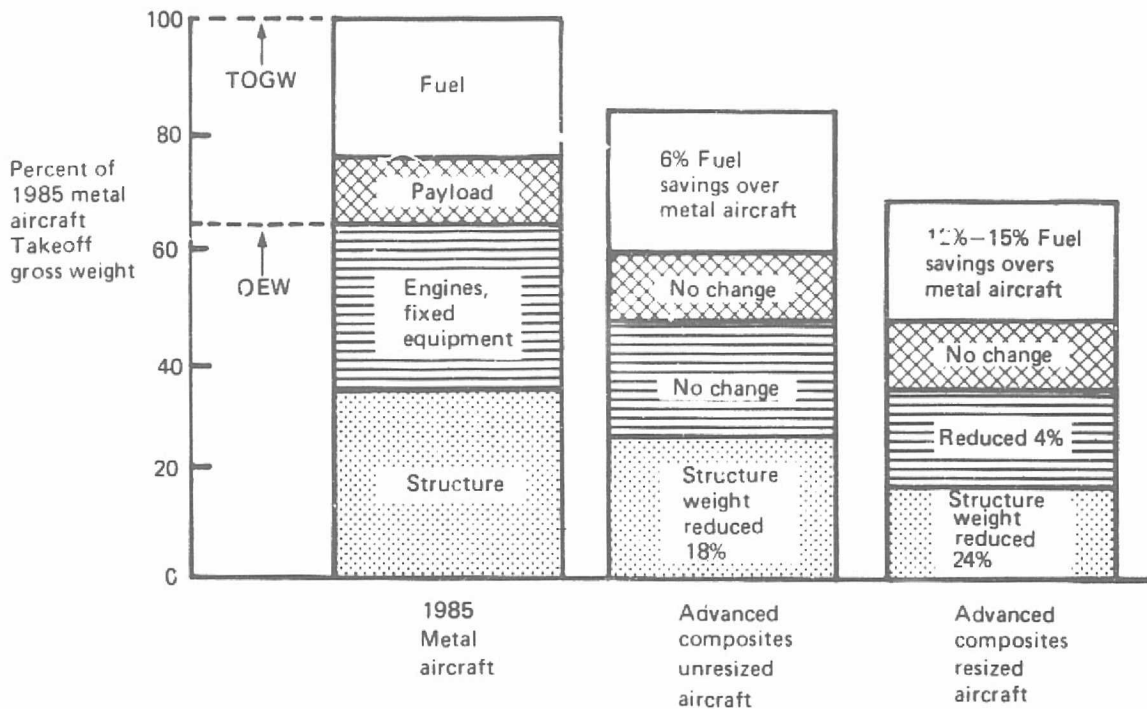

Figure 2-2 Weight Reduction and Fuel Savings Using Advanced Composites

Boeing Commercial  
Airplane Company  
Contract NAS1-15003

Further, fabrication costs for a production airplane are expected to be less than the cost of current aluminum structure. This is achieved by the proposed use of automatic machinery, such as tape laying and filament winding machines, and by reduced advanced composites material costs, based on increased industry usage.

For manufacturing, the use of automatic machinery, and increased industry usage and development of advanced composites thus reducing material cost, could enable manufacturing costs to be reduced 20% below current costs for the same aluminum structure.

## 2.2 REPORT/CONTRACT INTERFACE

The study objective, as summarized in the contract is "...to define the technology and data needed to support the introduction of advanced composites materials into the wing structure of future production aircraft, and to develop, in detail, appropriate program options for a contractual, structural development program that will provide the needed technology and data." The "Study on Utilization of Advanced Composites in Commercial Aircraft Wing Structures" was authorized and funded under NASA Contract NAS1-15003, effective August 1, 1977. It was completed in 10 1/2 months, including submission of the final report, by an integrated design, staff, and manufacturing research and development team (Figure 2-3) that averaged eight people/month over the period of the study.

The study effort was divided into the four tasks described below.

- Task I, Technology Assessment, established a baseline structural concept, and defined the additional technology and production capability required.

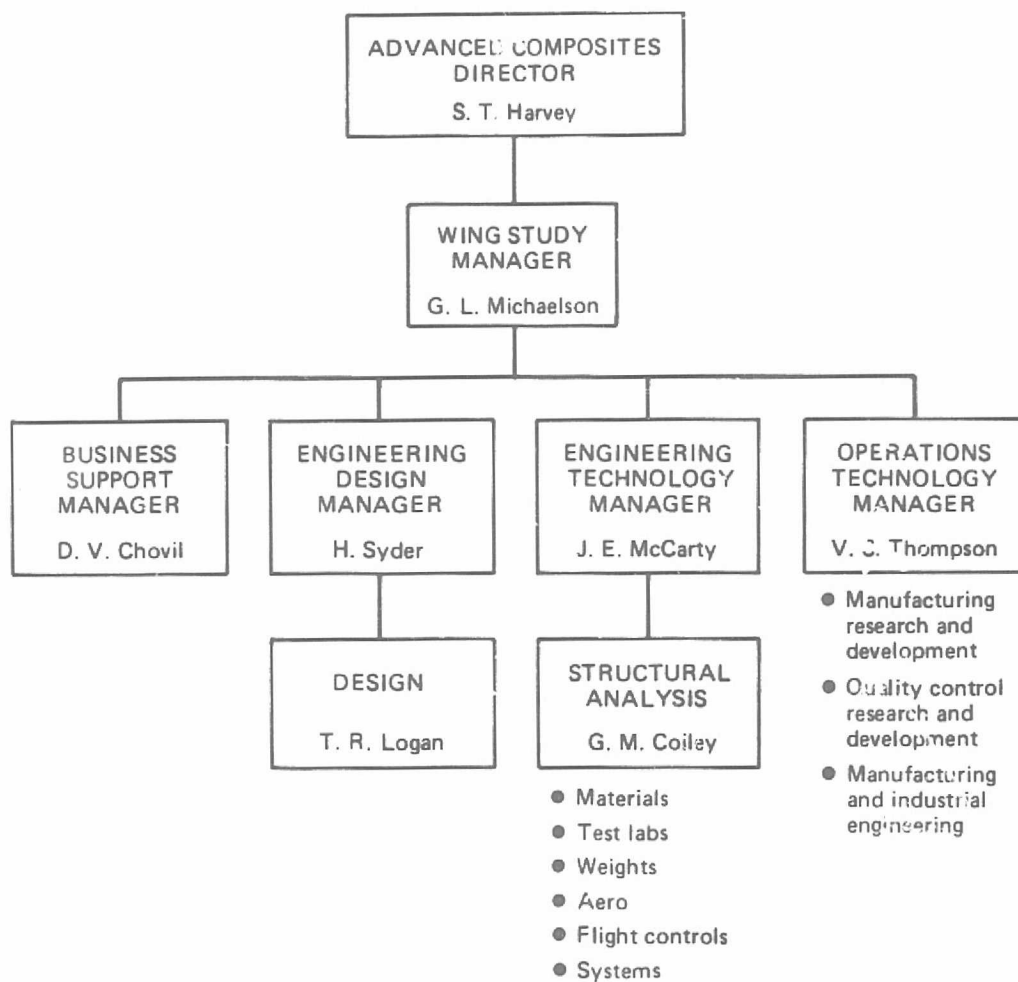

Figure 2-3 Advanced Composites Wing Study—Organization

Boeing Commercial  
Airplane Company  
Contract NAS1-15003

- Task II, Management Analysis and Evaluation, involved FAA and airline coordination, cost analysis, and risk/benefit analysis for the use of advanced composites material in the primary structure of commercial transport airplane wings.
- Task III, Program Definition, developed major test plans, detailed plans for four wing structural development hardware options, and defined a recommended program to include technology development, production capability development, and integration and validation of these development efforts.
- Task IV, Contract Reports and Reviews, produced the monthly progress reports, two oral reviews at NASA, Langley, and the final study report.

This final report presents results of the tasks organized topically and separated into two volumes for easier understanding. Volume 1, "Executive Summary," (NASA CR 145382-1) is a condensed version of the full report. It focuses on the study methodology and the recommended program. Volume 2, "Final Report," (NASA CR 145382-2) is the full technical report covering study methodology, details of structural concepts, technology and production capability assessments and needs, FAA and airline coordination, and alternative program development.

## SECTION 3.0

### STUDY PROGRAM OVERVIEW

This section describes the process used during the study to: a) establish the current level of advanced composites technology, b) develop a wing box design concept, and c) specify major design needs. The iterative interaction of these elements with production capability generated the needs in each element that formed the basis for the recommended program.

Ground rules were established early in the study to form a framework for the effort. The target year for a production readiness commitment was fixed as 1985, which is a reasonable time based on the current state-of-the-art of advanced composites, on-going programs, future technology advances, and current market demands. Further, establishing readiness to proceed with a production commitment by 1985 would allow adequate time to make extensive use of advanced composites in wings of commercial aircraft entering service in the 1985-1990 time period.

Maximum use of advanced composites in the wing box was established as a ground rule with emphasis on the use of graphite/epoxy materials. The conceptual design was to concentrate on the primary structural box, with consideration given to interfacing control surfaces and the installation of systems.

~~PRECEDING PAGE BLANK NOT FILLED~~

Cost is an essential element in a production commitment. Therefore, a ground rule was established that the advanced composites wing costs should be competitive with aluminum wing cost. Design and manufacturing trade studies were heavily influenced by this cost target. A production rate ground rule of 8 airplanes per month was selected to assist in identifying facility needs. Weight reduction is the major benefit from the use of advanced composites in airplane structure. A weight reduction ground rule, which agrees with the contract statement of work, was established at a minimum of 25% reduction from the current aluminum wing box. A 25% weight reduction compared to current materials is an attractive possibility that requires validation.

The first portion of the study concentrated on an assessment of the existing technology base, and the development of a baseline structural concept. Technology contributions from on-going NASA, DOD, and industry programs were included in the assessment. This effort resulted in the identification of developmental needs required to apply advanced composites to wing structure. Test and development plans, including schedules and cost estimates, were established for both engineering and manufacturing items.

Finally, four development integration and validation hardware options involving fabrication and test of major structural components were selected, representing different levels of risk and cost.

Boeing Commercial  
Airplane Company  
Contract NAS1-15003

These four options were then evaluated in terms of technical risk, cost, feasibility, and benefits. One option was selected and combined with the technology development and production capability development efforts to form the recommended program that best meets the study objective.

### 3.1 STRUCTURAL CONCEPTS STUDIES

#### 3.1.1 Design

This section presents a description of the wing structural and systems installations concepts, together with rationale for concept selection. Design effort was on the wing box and principal systems, with only sufficient detail design generated to validate the overall concept. As the goal of the study was to prepare a wing structural development plan, the design was developed only to the extent that it served planning purposes. The design development process was closely coordinated with manufacturing and engineering technology planning to ensure that the designs would be compatible with production capability and engineering technology anticipated to be available in 1985.

#### 3.1.2 Baseline Design

In order to have an aluminum wing for comparison, a baseline airplane was selected that represents anticipated 1985 configurations, as shown in Figure 3-1. The airplane selected is a wide-body design with a takeoff gross weight in the 136 000 kg (300 000-lb) range. The wing has a 4580-cm (150-ft) span, utilizes an advanced airfoil, and has a structural box weight of approximately 10 440 kg (23 000 lb).

The wing shown in Figure 3-2 consists of a structural box made of left and right outboard sections joined to a wing center section at the side-of-body, fixed leading and trailing edges, leading-edge flexed Krueger flaps, trailing-edge single-slotted flaps, ailerons, spoilers, and a wing tip. The outboard structural box, shown in Figure 3-3, is a stringer-stiffened skin, two-spar design with internal ribs and bulkheads located to support the various high-lift devices and control surfaces, and to compartment the integral fuel tank. The center section structural box consists of stringer-stiffened skins, front and rear spars, and spanwise full-depth beams.

All evaluations were made relative to this wing design, which acted as a check and focal point for the design concept development. Basic wing planform and major detail geometry were available, as were other details such as control surfaces, fuel system, and fuselage interface. A computer program based on parametric data was used to establish internal loads, box stiffness data, and basic panel and spar gages for the aluminum design.

### 3.1.3 Conceptual Design

The goal of the conceptual design phase was to define the advanced composites wing structure in sufficient detail to form the basis for the development program and the manufacturing plan. Design and producibility were considered together, with the principal thrust of the design effort being to develop concepts that exploit the manufacturing advantages of advanced composites to produce low-cost structure. Thus, manufacturing suitability was emphasized equally with structural efficiency during the screening process.

A preliminary evaluation, which considered four categories of wing structure assembly and component definition, was performed to quickly focus further effort on concepts that were meaningful to the study goals. The first

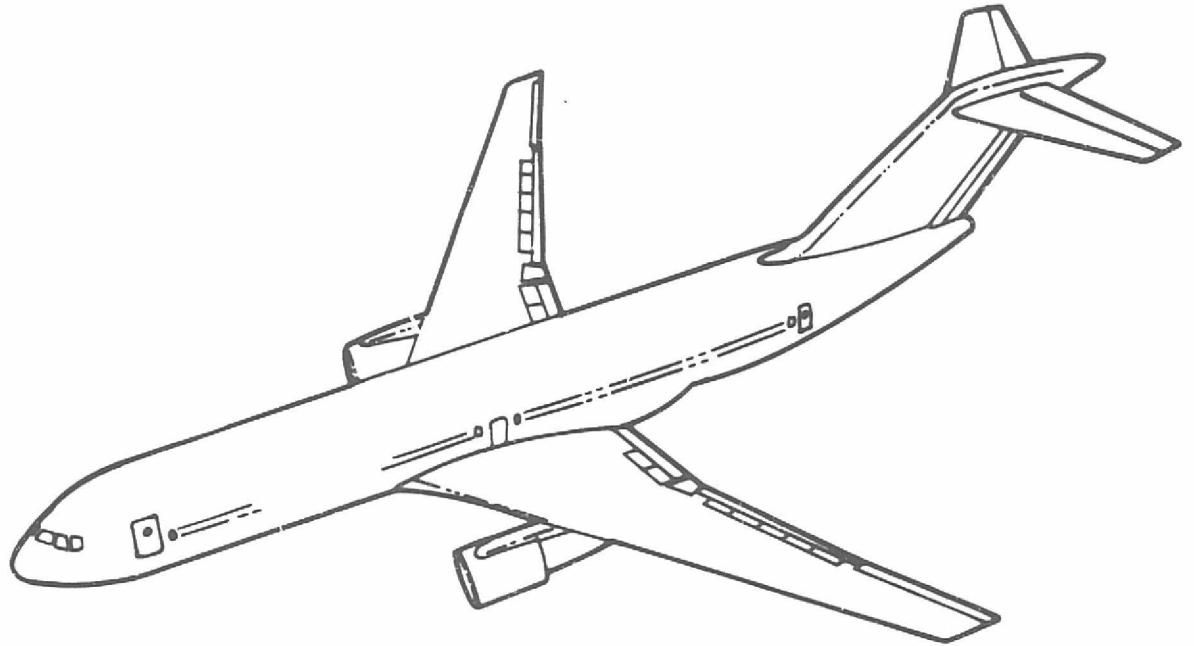

Figure 3-1 Baseline Airplane

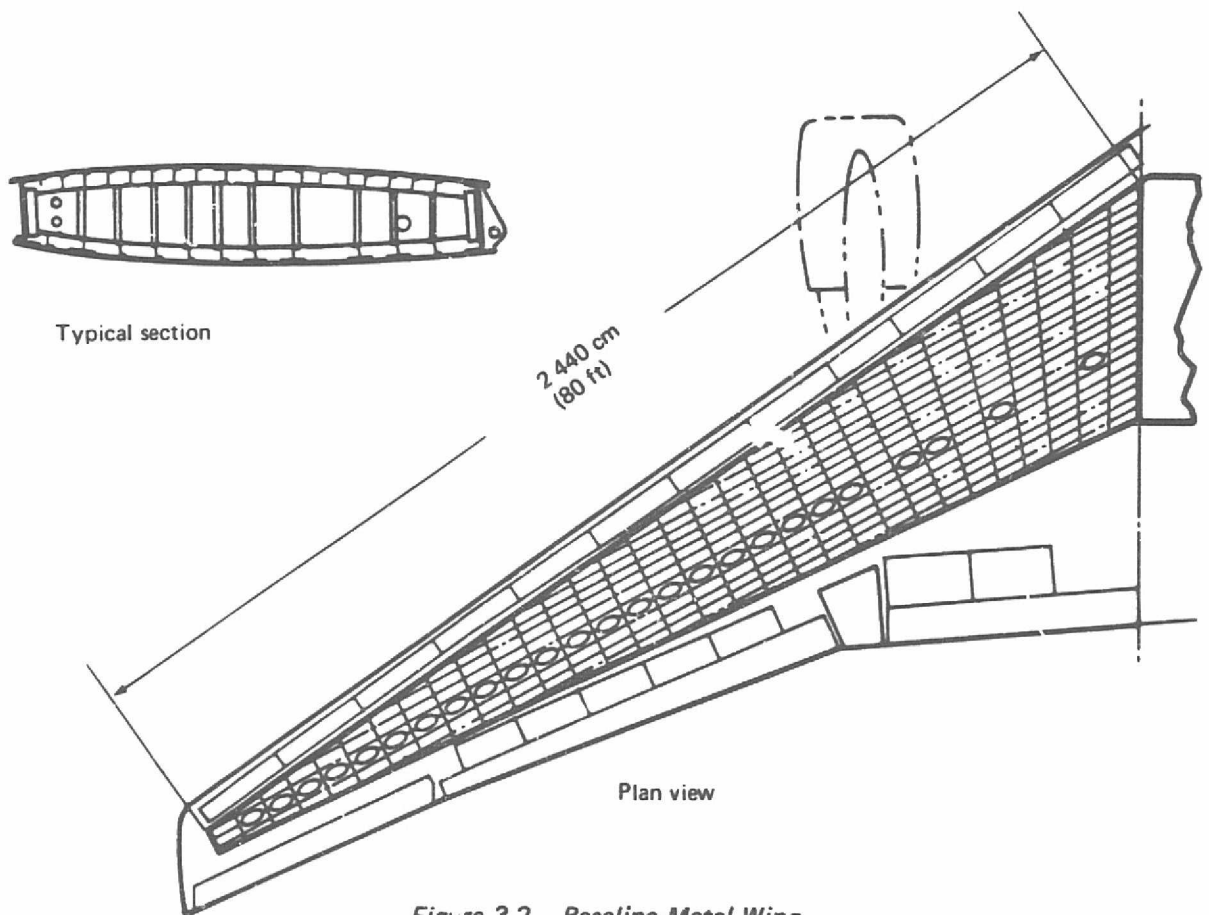
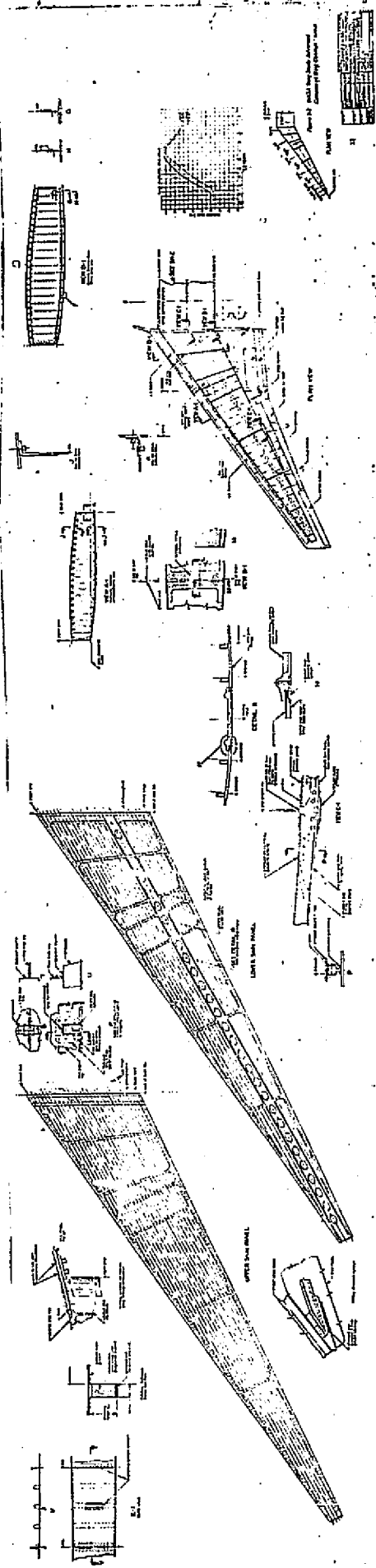

Figure 3-2 Baseline Metal Wing

RECORDING PAGE BLANK NOT FILMED



ORIGINAL PAGE IS  
OF POOR QUALITY

Boeing Commercial  
Airplane Company  
Contract NAS1-15003

category considered the overall planform configuration, which influences major manufacturing floor space, layup procedures, and tooling. Variations included full-span skins and various production splice locations. The second category included major cross section assembly breakdowns, from one piece to built-up, in order to assess influence of design on major assembly procedures and requirements. The third and fourth categories considered substructure and skin panels, respectively, and primarily evaluated structural efficiency and subassembly manufacturing procedures.

Concepts for this initial level of evaluation were broad and not defined in detail. Thus, to evaluate overall effects of wing skin size, the layup does not need to be defined, nor does the exact stringer shape need to be defined to evaluate various skin panel configurations.

Concepts were evaluated on a relative basis by comparing design advantages and disadvantages, together with relative structural efficiency, primarily based on previous studies and qualitative evaluations. Manufacturing suitability was carefully evaluated to establish relative rankings. An important part of the evaluation was assessment of manufacturing and processing improvements that would be available in the design time period. For this level of evaluation, it was judged that systems interfaces and requirements would be essentially the same for all concepts, and so were not specifically considered. Tables 3-1, 3-2, 3-3, and 3-4 summarize results of the design/producibility study for overall wing planform, wing cross section, substructure elements, and skin panel configurations, respectively.

Manufacturing preferences in the trades were based on an anticipated production rate of eight airplanes per month. These preferences tended to favor the designs that afford (a) the ability to subassemble in workable size assemblies to provide production flexibility (b) best work access for

Table 3-1. Design/Producibility Evaluation—General Configuration (Planform)





Concept	Design advantage	Design disadvantage	Manufacturing suitability*	Remarks/summary**
<p>① Full-span skin</p>  <p>● CAN ACCOMMODATE EITHER CENTER OR SIDE-OF-BODY SWEEP BREAK</p>	<ul style="list-style-type: none"> <li>Deletes skin splice at SOB—potential cost + weight saving</li> <li>Provides high degree of design flexibility in sweep break area, but depends on stiffening concept</li> </ul>	<ul style="list-style-type: none"> <li>Material layup discontinuity at planform change</li> <li>Difficult to control stiffeners around sweep break. Function of stiffening, detail design</li> <li>Limits cross section concept due to size and practicality</li> </ul>	<ul style="list-style-type: none"> <li>Requires excessively large autoclave or atmospheric pressure curing system</li> <li>Assembly advantage due to lack of splice, but possible handling problems</li> <li>High risk due to size (layup)</li> <li>Difficult fit-up due to size</li> <li>NDT machine size excessive, if used</li> <li>Requires more detail definition for further analysis</li> </ul> <p>Manufacturing rating 3</p>	<p>Requires major technology improvements to become viable. Merits further study as long term growth concept because of potential weight and cost savings</p> <p>Rank 3</p>
<p>② Half-span skin</p> 	<ul style="list-style-type: none"> <li>Replace two SOB splices with one center splice—potential cost and weight saving but less than concept ①</li> <li>Slightly improved reparability compared to concept ①</li> </ul>	<ul style="list-style-type: none"> <li>Material layup discontinuity at sweep break, coupled with splice buildup</li> <li>Same as for concept ①</li> </ul>	<ul style="list-style-type: none"> <li>Requires larger autoclave and NDT equipment than concepts ③ and ④, but considerably smaller than concept ①</li> <li>Handling fit-up more difficult than concepts ③ and ④, but considerably simpler than concept ①</li> </ul> <p>Manufacturing rating 2</p>	<p>Will not be considered further due to lack of significant advantages compared to other concepts</p> <p>Rank 4</p>
<p>③ Center section</p>  <p>● SPLICE LOCATION VARIABLE</p>	<ul style="list-style-type: none"> <li>Replaces SOB splices with out-board splices. Savings potential low, but depends on loads</li> <li>Splice could be simpler than concepts ② or ④ depending on location</li> <li>Improved reparability compared to concepts ① and ②</li> <li>High degree of design flexibility in sweep break area</li> </ul>	<ul style="list-style-type: none"> <li>Same as for concepts ① and ②</li> </ul>	<ul style="list-style-type: none"> <li>Saves some time in final assembly by allowing earlier work on systems test, fuel seal and test</li> <li>Potential assembly fit-up problems for box due to complexity of shape</li> </ul> <p>Manufacturing rating 2</p>	<p>Similar to concept ④ since wing is in three sections. Splice location effect should be further evaluated for potential advantage particularly to manufacturing fabrication and assembly. Can be developed as a step toward concept ①</p> <p>Rank 2</p>
<p>④ Side-of-body</p> 	<ul style="list-style-type: none"> <li>Established design parameters (load paths, fuselage attachment) but not significant</li> </ul>	<ul style="list-style-type: none"> <li>Sweep splice is in complex area, has fixed location</li> <li>Lacks design flexibility of other concepts in center section</li> </ul>	<ul style="list-style-type: none"> <li>Known production situation is an advantage to overall manufacturing sequence</li> <li>Splice is in complex area, but problems are centralized</li> </ul> <p>Manufacturing rating 1</p>	<p>Selected as base design for study purposes due to lack of decisive advantages of alternates</p> <p>Rank 1</p>
			*Manufacturing rating 1 through 4	**Overall ranking 1 through 4

Table 3-2. Design/Producibility Evaluation—General Configuration (Cross Section)



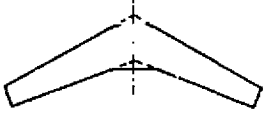

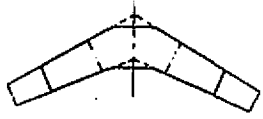
Concept	Design advantage	Design disadvantage	Manufacturing sustainability*	Remarks/summary**
<p>① One-piece box</p> 	<ul style="list-style-type: none"> <li>• Superior continuity at corners</li> <li>• Anticipated moderate weight saving due to joint deletion at corners</li> <li>• Least fuel tank sealing requirement</li> </ul>	<ul style="list-style-type: none"> <li>• Lacks design flexibility due to required corner details (minor)</li> <li>• Compromises rib design, depending on configuration</li> </ul>	<ul style="list-style-type: none"> <li>• Could be filament wound, but state-of-the-art advancement required not projected to 1985-1990</li> <li>• Alternative fabrication processes not viable, particularly layup</li> <li>• Poor access for substructure installation</li> <li>• Problems with inspection and repair (manufacturing)</li> </ul> <p>Manufacturing rating 3</p>	<p>Structural advantages minor compared to manufacturing complexity, depends on substructure configuration</p> <p>Will not be studied further due to lack of practicality</p> <p>Rank 4</p>
<p>② One-piece lower box</p> 	<ul style="list-style-type: none"> <li>• Provides superior cover/spar joint on tension side</li> <li>• Improved substructure installation, design compared to concept ①</li> </ul>	<ul style="list-style-type: none"> <li>• Same as for concept ① at lower corners</li> </ul>	<ul style="list-style-type: none"> <li>• Improved accessibility to concept ①</li> <li>• Layup, curing difficult in lower corners</li> <li>• Good potential for filament winding</li> </ul> <p>Manufacturing rating 2</p>	<p>Will not be studied further due to lack of significant advantages over concept ④</p> <p>Rank 3</p>
<p>③ Split box</p> 	<ul style="list-style-type: none"> <li>• Provides advantages of concept ①. Developed to provide manufacturing flexibility</li> <li>• Joint easier than for concept ② since situated away from corner</li> </ul>	<ul style="list-style-type: none"> <li>• Same as concept ①</li> <li>• Limits spar web design concept due to splice</li> <li>• Not compatible with multi-spar concept</li> </ul>	<ul style="list-style-type: none"> <li>• Improved accessibility to concepts ① and ②</li> <li>• Requires either split ribs or ribs/spar joint in closed box</li> <li>• Good potential for filament winding</li> </ul> <p>Manufacturing rating 2</p>	<p>Similar to concept ④ if stub spar webs only are used</p> <p>Will not be studied further due to lack of significant advantages over concept ④</p> <p>Rank 2</p>
<p>④ Built-up box</p> 	<ul style="list-style-type: none"> <li>• Simplified fabrication due to smaller parts</li> <li>• Established design techniques</li> <li>• Spar cap buildup can be included in covers</li> </ul>	<ul style="list-style-type: none"> <li>• Limited development of composite design potential</li> <li>• Maximizes assembly joint penalties, but probably not large</li> <li>• Tank sealing difficult, but techniques are established</li> </ul>	<ul style="list-style-type: none"> <li>• Established manufacturing procedures</li> <li>• Superior tooling, work access</li> <li>• Higher assembly costs than others</li> <li>• Least difficult repairs, modifications</li> <li>• Most producible configuration for anticipated commitment</li> <li>• Lowest risk due to part size</li> </ul> <p>Manufacturing rating 1</p>	<p>Selected as base design because of superior manufacturability for 1985 time period</p> <p>Rank 1</p>
			*Manufacturing rating 1 through 4	**Overall ranking 1 through 4

Table 3-3. Design/Productivity Evaluation—Substructure Configuration



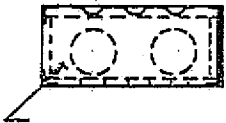

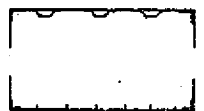



Concept	Design advantage	Design disadvantage	Manufacturing suitability*	Remarks/summary**
<p>① Multispar</p>  <p>● SOLID LAMINATE OR SANDWICH SPARS, COCURED OR BONDED</p>	<ul style="list-style-type: none"> <li>● Potential weight saving</li> <li>● Potential for filament winding</li> </ul>	<ul style="list-style-type: none"> <li>● Requires partial ribs at concentrated load</li> <li>● Requires fuel bulkheads</li> <li>● Poor maintenance access, or requires excessive access openings</li> </ul>	<ul style="list-style-type: none"> <li>● Poor assembly access, particularly in outboard sections</li> <li>● Good potential for filament winding and bonding cells. Not projected to commitment time period</li> </ul> <p>Manufacturing rating 4</p>	<p>Weight saving can be offset by minimum gage considerations</p> <p>Will not be studied further due to lack of significant advantages; manufacturing problems should be reconsidered for filament winding</p> <p>Rank 2</p>
<p>② Truss rib</p>  <p>● TRUSSES PREFABRICATED FROM PULTRUDED SECTIONS, ASSEMBLED BY BONDING</p>	<ul style="list-style-type: none"> <li>● Uses simple, repetitive details</li> <li>● Uses pultrusions</li> <li>● Potential weight saving</li> <li>● Simplified subassembly</li> <li>● Good maintenance and repair access</li> </ul>	<ul style="list-style-type: none"> <li>● Requires fuel bulkheads</li> <li>● Probably requires precured elements to be practical</li> </ul>	<ul style="list-style-type: none"> <li>● Simple rib fabrication, but large number of parts</li> <li>● Good access</li> <li>● Requires careful attention to design to avoid costly joints</li> <li>● Requires rib to be assembled before installation</li> </ul> <p>Manufacturing rating 2</p>	<p>Installation similar to concept ①</p> <p>More costly than concept ① due to large number of parts</p> <p>Rank 4</p>
<p>③ Post</p>  <p>● POSTS PREFABRICATED, INSTALLED DURING BOX ASSEMBLY INTO FITTINGS IN COVERS</p>	<ul style="list-style-type: none"> <li>● Uses simple, repetitive details</li> <li>● Potential weight saving</li> </ul>	<ul style="list-style-type: none"> <li>● Post end moment, loads offset</li> <li>● weight saving for thin skins</li> <li>● Requires fuel bulkheads, partial ribs at concentrated loads</li> <li>● Requires additional member to transmit vertical loads to spars</li> </ul>	<ul style="list-style-type: none"> <li>● Lack of experience a negative factor (probably short term)</li> <li>● Good work access, inspectability</li> <li>● Large number of pieces</li> </ul> <p>Manufacturing rating 3</p>	<p>Variation of concept ① from practical point of view</p> <p>Will not be studied further due to lack of significant advantages compared to concept ①</p> <p>Rank 3</p>
<p>④ Solid rib</p>  <p>● RIBS BUILT UP OR SANDWICH INSTALLED BONDED OR LOCKBOLTS</p>	<ul style="list-style-type: none"> <li>● Same basic design serves all rib requirements</li> <li>● Established experience base</li> </ul>	<ul style="list-style-type: none"> <li>● Built-up component can be complex due to part count</li> </ul>	<ul style="list-style-type: none"> <li>● Conventional assembly, known installation problems</li> <li>● Adequate work access</li> <li>● High potential for automation due to flat panel</li> </ul> <p>Manufacturing rating 1</p>	<p>Selected as baseline design because of superior productivity, competitive weight</p> <p>Rank 1</p>
			*Manufacturing rating 1 through 4	**Overall ranking 1 through 4

Table 3-4. Design/Productibility Evaluation—Skin Panel Configurations

Concept	Design advantage	Design disadvantage	Manufacturing suitability*	Remarks/summary**
<p>① Sandwich</p>  <ul style="list-style-type: none"> <li>• Aluminum or nonmetallic cores</li> </ul>	<ul style="list-style-type: none"> <li>• High structural efficiency but dependent on load range</li> <li>• Relatively well established technology</li> <li>• Simple rib attachment</li> <li>• Better chordwise load path than other concepts</li> </ul>	<ul style="list-style-type: none"> <li>• Joints, attachments relatively complex, but techniques are well established</li> <li>• Uncertain inspectability of hidden face sheet (service)</li> <li>• Repairs difficult (compared to concepts ③, ④, and ⑤)</li> <li>• Reduces fuel volume</li> <li>• May require intermediate spar caps for efficiency</li> </ul>	<ul style="list-style-type: none"> <li>• Excellent producibility if core thickness is not sculptured</li> <li>• Potentially most inspectable and lowest cost to manufacture</li> <li>• Difficult to repair, but basic technology is established</li> </ul> <p>Manufacturing rating 1</p>	<p>Requires detailed study to clarify technical position. Not studied further for this program</p> <p>Rank 3</p>
<p>② Single face sandwich</p> 	<ul style="list-style-type: none"> <li>• Better inspectability than concept ①</li> <li>• Wide variety of stiffening shapes available to improve producibility</li> </ul>	<ul style="list-style-type: none"> <li>• Joints, attachments heavy, complex</li> <li>• Requires development</li> <li>• Repairs difficult (compared to concepts ③, ④, and ⑤)</li> <li>• Fuel leaks difficult to locate</li> </ul>	<ul style="list-style-type: none"> <li>• Difficult close-out attachment</li> <li>• Complex tooling</li> </ul> <p>Manufacturing rating 5</p>	<p>Will not be studied further because of disadvantages</p> <p>Rank 5</p>
<p>③ Built-up stiffeners</p>  <ul style="list-style-type: none"> <li>• Stiffeners can be integral or bonded onto skin</li> <li>• Y, J, Z shapes common</li> </ul>	<ul style="list-style-type: none"> <li>• Better inspectability than concepts ① and ②</li> <li>• Wide variety of stiffener shapes available</li> <li>• Well established design parameters</li> </ul>	<ul style="list-style-type: none"> <li>• Splices probably heavier than concept ④</li> <li>• Rib attachment moderately complex</li> </ul>	<ul style="list-style-type: none"> <li>• Good producibility</li> <li>• Good rib attachment, end treatment compared to concepts ① and ③</li> <li>• Significantly complex NDI techniques and costs</li> </ul> <p>Manufacturing rating 3</p>	<p>Not studied further for this program</p> <p>Rank 2</p>
<p>④ Blade stiffeners</p>  <ul style="list-style-type: none"> <li>• Solid blades, integral or bonded on</li> <li>• Built-up blades, integral or bonded on</li> </ul>	<ul style="list-style-type: none"> <li>• Efficiency competitive with concept ③, lower than ①</li> <li>• Rib attachments, joints simpler than concepts ②, ③, and ⑤</li> <li>• Wide variety of blade designs available to suit design, manufacturing requirements</li> </ul>	<ul style="list-style-type: none"> <li>• Requires more development than concept ③</li> <li>• Potential efficiency loss under combined load cases, but depends on design</li> </ul>	<ul style="list-style-type: none"> <li>• Good producibility</li> <li>• Simple end treatment</li> <li>• Better inspectability than concept ③</li> </ul> <p>Manufacturing rating 2</p>	<p>Selected as baseline design due to design flexibility, competitive producibility</p> <p>Rank 1</p>
<p>⑤ Hats</p>  <ul style="list-style-type: none"> <li>• Built-up or solid laminate, integral or bonded on</li> </ul>	<ul style="list-style-type: none"> <li>• High structural efficiency</li> <li>• Wide variety of hat designs available</li> <li>• Better skin support than other stiffeners</li> <li>• Stiffener has superior local and torsional stiffness</li> </ul>	<ul style="list-style-type: none"> <li>• Difficult rib attachment</li> <li>• Splices more difficult than concept ④, similar to ③</li> <li>• Repairs more difficult than concepts ③ and ④</li> </ul>	<ul style="list-style-type: none"> <li>• More difficult to produce and attach ribs than concepts ③ and ④</li> <li>• Significantly complex NDI techniques and costs</li> <li>• Complex tooling</li> </ul> <p>Manufacturing rating 4</p>	<p>Will not be studied further due to anticipated producibility cost, development problems</p> <p>Rank 4</p>
			*Manufacturing rating 1 through 5	**Overall ranking 1 through 5

assembly operations, sealing, and inspection during and after wing assembly, and (c) a high level of automation for the fabrication phase.

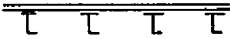
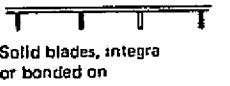
Based on this evaluation, a wing with splices at the side-of-body locations (Concept 4) was selected as the baseline design, as shown in Table 3-1. Without further design effort, there are no obvious decisive advantages for the other concepts. However, Concept 1 is considered to have a very high risk from both development and in-process part loss viewpoints for the 1985 time period, and concepts such as 3 and 4 were preferred. Similarly, as shown in Table 3-2, Concept 4 was chosen as the baseline design because of superior producibility and competitive structural efficiency. This level of design/producibility evaluation yielded a wing with a manufacturing assembly breakdown compatible with anticipated practical production techniques, work station arrangements, and assembly requirements.

Substructure and skin panel concepts were evaluated, using the same procedure and ground rules as discussed above, but in more detail. For metal wing structure of the type being considered, skin panels generally represent the majority of the wing structural weights, but only a small fraction of the fabrication and assembly cost. Conversely, the substructure weighs considerably less than the skin panels, but dominates the cost. Therefore, concept development for the major box components emphasized structural efficiency for the skin panels, but low cost for the substructure. Further details of fabrication and assembly methods selected are given in Paragraph 4.2.3.

A two-spar, multirib, stringer-stiffened skin structural arrangement was selected for the baseline design. As shown in Table 3-3, solid ribs were selected after consideration of the relative costs of truss and solid rib designs. Sandwich ribs were also considered, but an integrally-stiffened,

solid-laminate design was selected to provide better compatibility with the manufacturing method selected and to avoid sealing complications associated with the honeycomb design.

Skin panel designs were studied in depth with results summarized in Table 3-4 and with further details given in a following discussion. Because of the stiffness constraint imposed on the box design (matching metal wing bending and torsional stiffnesses), panel concepts such as Concept 5 with very high panel buckling efficiency provide insufficient box stiffness, and less buckling efficient concepts such as Concept 4 are weight competitive. Since the blade concepts have superior producibility potential, they were selected. However, this conclusion should be reexamined if required wing stiffness criteria are significantly decreased compared to equivalent aluminum designs.

#### 3.1.4 Advanced Composites Design-Outboard Wing Box

The advanced composites design concepts for the outboard wing box are detailed in Figure 3-3. Construction concepts and pertinent details are contained in the following descriptions.

Upper Panel-The upper panel is a graphite/epoxy fabric and tape layup extending from the side-of-body to near the wing tip, curved in both spanwise and chordwise directions. Contours are controlled by three-dimensional mathematical definition.

Stringers, approximately 25 in number, are secondarily bonded to the precured skin layup. Stringers are constructed of primarily unidirectional graphite/epoxy layup. Stringers are constructed of primarily unidirectional graphite/epoxy cap pieces spaced apart by a honeycomb core material. Closure or

Boeing Commercial  
Airplane Company  
Contract NAS1-15003

wrap plies, between stringers and over the stringer upper cap, are added and cured with the stringer-to-skin bond to prevent fuel ingress to the stringer core material and to tie the caps together.

The skin layup is primarily  $\pm 45^\circ$  material, with the remainder being  $0^\circ$  and  $90^\circ$ . The skin panel is padded on the tool side at the side-of-body joint to approximately one rib bay length out from the joint. The skin panel is mechanically attached to the spars and ribs.

Lower Panel—The lower panel is a graphite/epoxy layup extending from side-of-body to near the wing tip, and from front spar to rear spar similar to the upper panel. The part is curved in both directions similar to the upper panel, with contours controlled by three-dimensional mathematical definition.

Panel construction is similar to the upper panel, except that there are only approximately 20 stringers and a row of access holes, one in each rib bay from the outboard end to the engine location and four between the engine and side-of-body.

Panel layup is similar to the upper panel, and pad-up requirements at the side-of-body joint are also similar. Reinforcement for access holes is provided by a cocured continuous doubler and local build-ups. Access doors are graphite/epoxy construction. Stiffener runouts are made by tapering stiffener ends and adding an end closure piece. The skin panels are mechanically attached to the spars and ribs.

Side-of-Body Rib—The side-of-body rib is a graphite/epoxy flat laminate with cocured "I"-section stiffeners spaced approximately 20 cm (3 in) apart, running vertically on the web. Rib web and stiffeners are mechanically

Boeing Commercial  
Airplane Company  
Contract NAS1-15003

attached to the upper and lower plus chord members, and the front and rear spar terminal fittings. Rib web size is approximately 114 cm (45 in) average depth, with a maximum of 152 cm (60 in), and is 496 cm (195 in) long.

Lower Side-of-Body Joint—The lower side-of-body joint is a double plus chord design, using a stretch-formed and machined titanium (6Al-4V annealed) doubler plus member internally between front and rear spars, and segmented external titanium splice plates, as shown in Figure 3-3.

Stringer loads are carried into the double plus chord through graphite/epoxy "Pi" cross section fittings bolted to stringer ends and double plus chord. Plus chord size is approximately 559 cm (220 in) long with skin leg attachment length of 11.4 cm (4 1/2 in) in both outer and center wing sections. Total depth of section is 16.5 cm (6 1/2 in).

Upper Side-of-Body Joint—The upper side-of-body joint is of the double plus chord design, similar to existing production airplanes. The double plus chord is a titanium (6Al-4V annealed) formed and machined extrusion extending from front to rear spars.

Stringer loads are carried into the plus chord through graphite/epoxy "Pi" cross section fittings, bolted to the stringer ends and double plus chord. The lower vertical leg of the plus chord attaches with mechanical attachments to the side-of-body rib web-stiffener panel and the upper vertical leg attaches by mechanical attachments to the body skin. The double plus chord length is approximately 559 cm (220 in) and it is approximately 25.4 cm (10 in) deep.

Typical Inspar Ribs—Typical inspar ribs are graphite/epoxy laminate with integral stiffening in a flat sheet web. The stiffeners are formed by using either preformed male inserts and a female tool cavity, or by matched metal cavity dies. Inspar ribs are mechanically attached to the skin panels and stiffeners at the front and rear spars.

Shear Tied Major Ribs—Shear tied major ribs are used at five locations in the wing box. Shear tied ribs are graphite/epoxy stiffened laminate webs. Web stiffening will be formed in a similar manner to the typical inspar ribs. Shear tied rib chords are pultruded angled "T" sections, bolted to stiffened laminate web, as shown in Figure 3-3. Ribs are mechanically attached to the skin panels and spar stiffeners.

Shear Tied Tank End Rib—One shear tied tank end rib is used as the outboard tank end of the inboard main tank, and also to carry landing gear forward trunnion loads. Construction is a graphite/epoxy laminate stiffened web with separate pultruded chords mechanically attached to the stiffened web similar to the shear tied major ribs.

The rib is mechanically attached to the upper and lower panels and spar stiffeners. Nonstructural graphite/epoxy molded seal fittings are required between stringers, and are mechanically attached to the rib and sealed to the stringers using conventional sealing methods.

Front and Rear Spar Terminal Fittings—Front and rear spar terminal fittings are titanium "T" extrusions, with legs angled to conform to the sweepback angles and also to pick up the side-of-body rib. Front and rear spar terminal fittings are mechanically attached to the spar webs in both the center and outboard wing sections and also the side-of-body rib web.

Front Spar—The front spar is a graphite/epoxy channel extending from the terminal fitting at side-of-body to near the tip area. Layup will be primarily  $+45^{\circ}$  in the web area, with additional unidirectional material in the cap areas. Inspar rib attachments will be provided by a combination of preformed inserts in the web layup and separate stiffeners of angle channel or "Z" section mechanically attached to the web.

Intermediate stiffeners and systems attachment provisions will also be made by a combination of preformed inserts and/or mechanically attached stiffeners. Fuel and electrical systems penetrations with web pad-ups are provided as required.

Spar stiffeners are spaced at approximately 20.3 cm (8 in) spacing and rib attachments at approximately 71 cm (28 in) spacing. Depth is approximately 127 cm (50 in) at the terminal fitting, tapering to 50.8 cm (20 in) at the engine centerline about 686 cm (270 in) from the side-of-body and to 25.4 cm (10 in) at the tip. The front spar is mechanically attached to the upper and lower skin panels.

Rear Spar—The rear spar is a graphite/epoxy channel extending from the terminal fitting at side-of-body to near the tip area. Layup is similar to the front spar, as is the method of attaching inspar rib stiffeners, intermediate stiffeners, and systems provisions. Fuel and electrical systems penetrations with web pad-ups are provided as required. Major fitting attachments, landing gear trunnion, landing gear beam outboard end, and flap track attach fittings are mechanically attached to padded web areas.

Intermediate stiffeners and systems attachment provisions are also made by a combination of preformed inserts and/or mechanically attached stiffeners. Spar stiffeners are spaced approximately 20.3 cm (8 in) apart, and rib attachments at approximately 71 cm (28 in). Depth is approximately 101.5 cm (40 in) at the inboard end, tapering to 50.8 cm (20 in) at the engine

Boeing Commercial  
Airplane Company  
Contract NAS1-15003

centerline about 635 cm (250 in) from the side-of-body and down to 20.3 cm (8 in) at the tip. The rear spar is mechanically attached to the upper and lower skin panels.

Systems and Control Surfaces—Study emphasis was on planning for development of primary structure so that control surfaces, high-life devices, and fixed leading and trailing edges were assumed to be graphite/epoxy and were not specifically designed. Other major systems interfaces were explored in depth, and a technology development plan was formulated as reported in the Technology Development paragraph (4.1).

Basic systems, such as control systems, fuel and propulsion systems, and electrical systems, will be similar to those for existing metal airplanes. Detail installations will be adapted to the advanced composites structure to allow for thermal expansion differences, electrical bonding, and corrosion protection. Lightning protection provision requirements, which are anticipated, can be accommodated in the basic structural design described above as they are developed.

### 3.1.5 Advanced Composites Design—Wing Center Section

The advanced composites design concepts for the wing center section are shown in Figure 3-4 and described below.

Upper Skin Panel—The upper panel is a one-piece graphite/epoxy fabric and tape layup, extending from the left side-of-body joint to the right side-of-body joint and from front to rear spars. The part is curved in the chordwise direction. Contour is controlled by a three-dimensional mathematical definition. Stringers, constructed of primarily unidirectional graphite/epoxy cap pieces spaced apart by a honeycomb core material, are secondarily

Figure 24. All-Steel Highway Advance Construction  
Type Concrete Ledge-Cover System

NO.	DESCRIPTION	DATE
1	DESIGNED	11/15/54
2	CHECKED	11/15/54
3	APPROVED	11/15/54

ORIGINAL PAGE IS  
OF POOR QUALITY

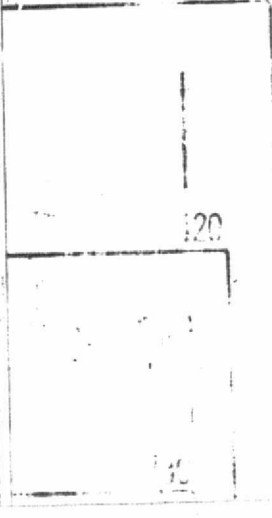
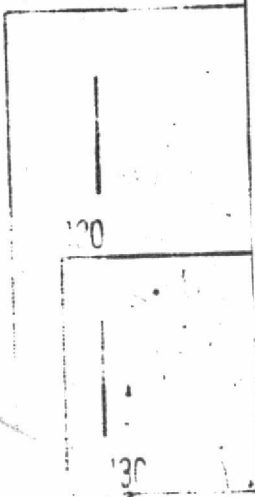
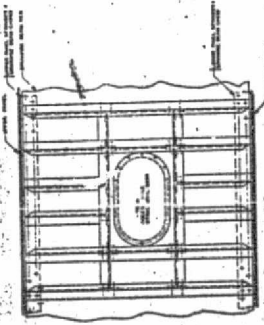
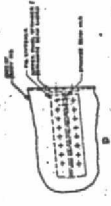
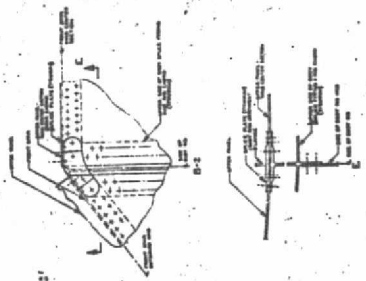
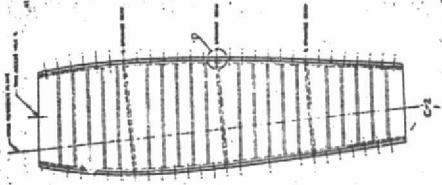
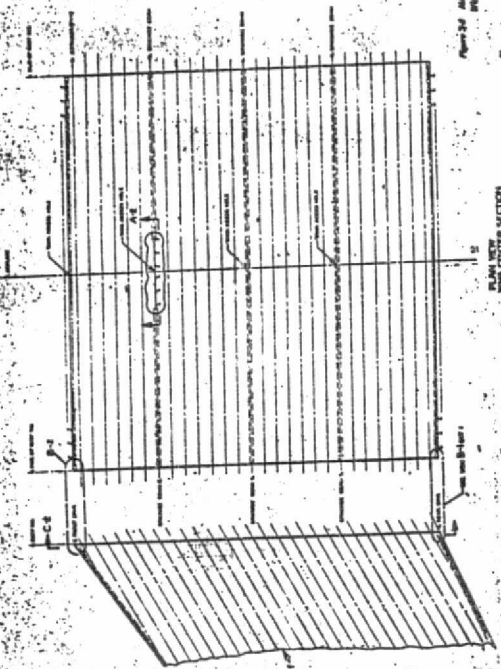

bonded to the skin panel at all but three locations to match the outer panel stringer centerlines.

The remaining three stringer locations use a precured "T" section stringer used for attachment of the spanwise beam web and stiffeners, secondarily bonded to the precured skin panel. Closure or wrap plies are added and cured with the stringer-to-skin bond. Closure plies do not wrap over "T" section spanwise beam attachment stringers. Skin layup is primarily  $\pm 45^\circ$  material, with the remainder being  $0^\circ$  and  $90^\circ$ . The upper panel is mechanically attached to the spars, spanwise beams, and side-of-body splices.

Lower Skin Panel—The lower panel is a one-piece graphite/epoxy fabric and tape layup, joining the left and right side-of-body joints and front-to-rear spars similar to the upper panel. The part is curved in the chordwise direction with contour controlled by mathematical definition.

Panel construction is similar to the upper panel, except there are only approximately 20 stringers, three of which are "T" sections used to attach the spanwise beam web and stiffeners. Panel layup is similar to the upper panel. The lower panel is mechanically attached to the spars, spanwise beams, and side-of-body splices.

Front Spar—The wing center section front spar is a graphite/epoxy channel cross section member, with flat laminate web and cocured "Z" section stiffeners spaced approximately 15.2 cm (6 in) apart, running vertically on the web. An access hole with a structural door is provided for assembly and inspection purposes. Pad-up around the access hold will be on the aft side of the web.

Padded areas are provided for fuel and electrical systems penetrations on the forward side of the web. Chord flanges are aft facing, for attachment to the upper and lower skin panels. The front spar web is attached to the

Boeing Commercial  
Airplane Company  
Contract NAS1-15003

front spar terminal fitting, using mechanical fasteners, and the spar cap members are spliced to the outer wing spar caps with mechanically attached splice plates.

Rear Spar—The wing center section rear spar is a graphite/epoxy channel cross section member with flat laminate web and cocured channel or "I"-section stiffeners, spaced approximately 20.3 cm (8 in) apart, running vertically on the web aft face.

Chord flanges are forward-facing for attachment to the upper and lower skin panels. Fuel and electrical systems penetrations are provided as required, with their associated web pad-ups located on the aft face of the web. The spar web is attached to the rear spar terminal fitting, using mechanical fasteners, and the spar cap members are spliced to the outer wing spar caps with mechanically attached splice plates.

Spanwise Beams No. 1 through No. 3—Wing center section spanwise beams are graphite/epoxy flat laminate web with "I" or channel-section stiffeners spaced approximately 15.2 cm (6 in) apart vertically on the web. An access hole with a structural door is provided in each spanwise beam for assembly and inspection purposes.

The access door area and any fuel and electrical systems penetrations are provided with padded areas. Web and stiffener ends are mechanically fastened to upper and lower "T"-section panel stiffeners.

### 3.1.6 Design and Weight Analysis

Major components of the box structure were detailed and analyzed to a sufficient depth to assure validity of the overall concept, and to establish weights for the advanced composites structure. Loads used were the same as the metal baseline loads, since the wing was not resized. Figures 3-5 and 3-6 show the average loads used at each wing station for the upper and lower panels, respectively. For this design effort, the advanced composites

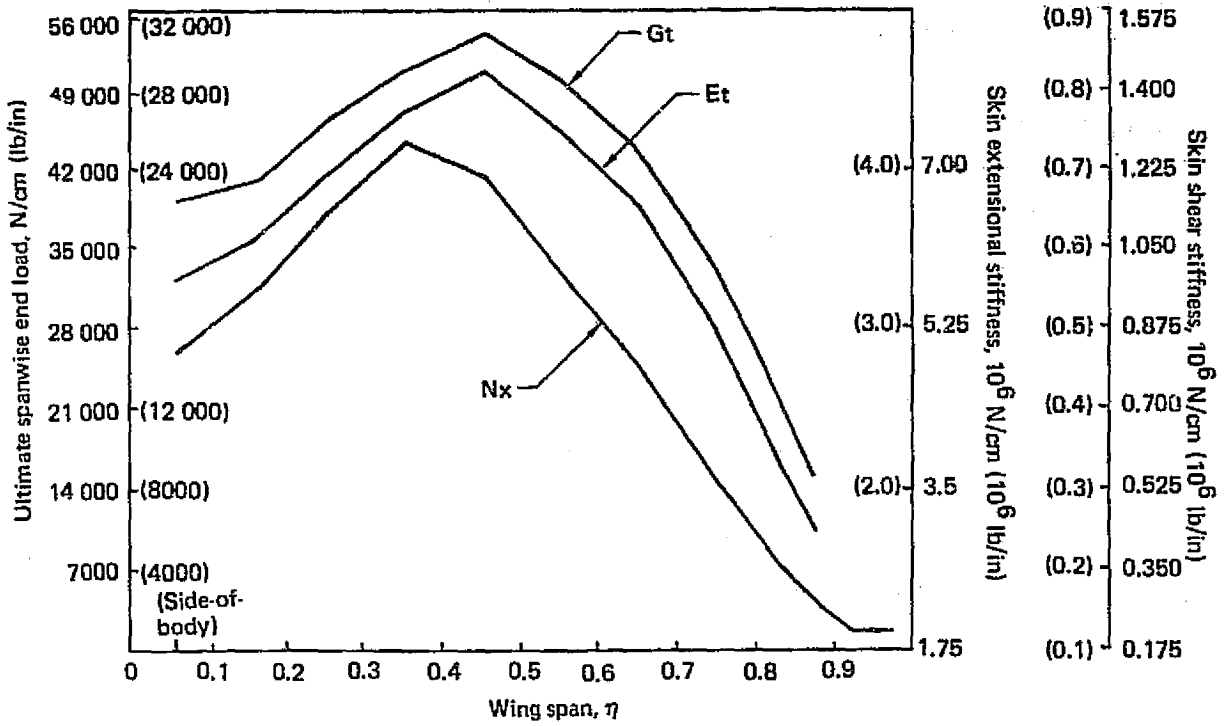

Figure 3-5. Wing Box Upper Panel Design Loads Stiffnesses

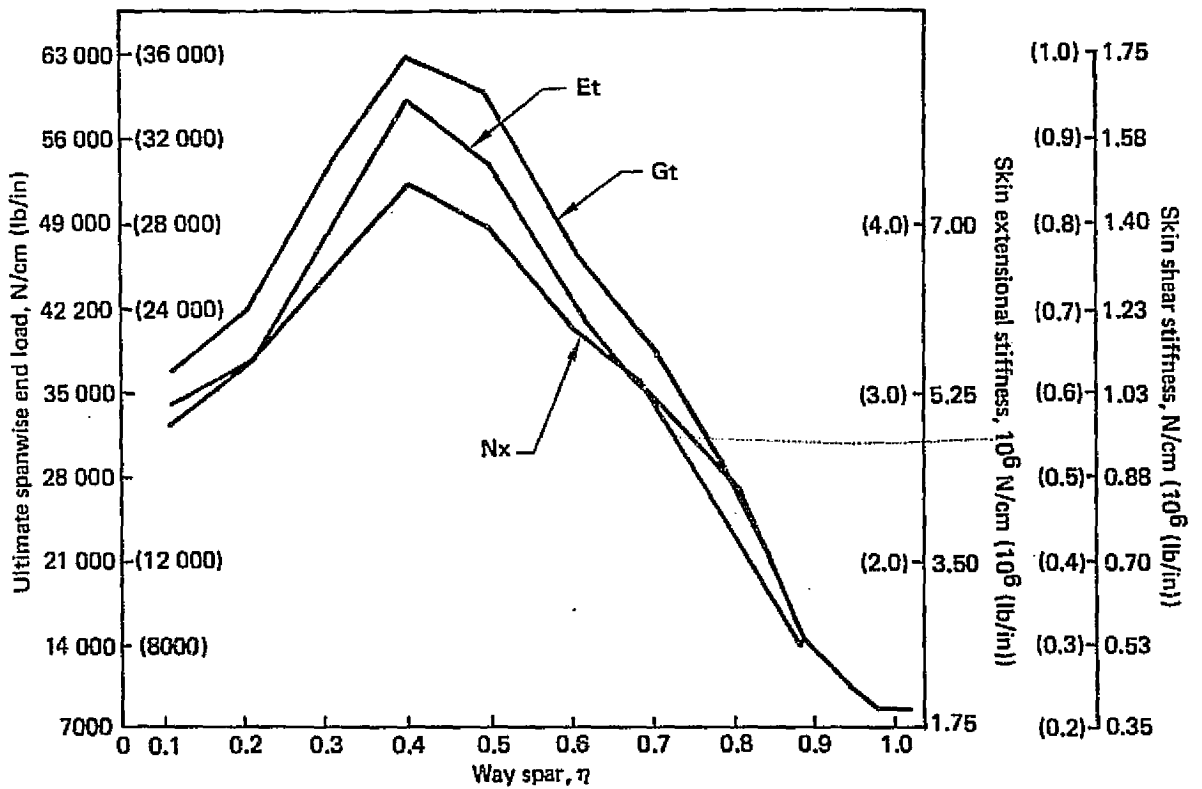

Figure 3-6 Wing Box Lower Panel Design Loads Stiffnesses

Boeing Commercial  
Airplane Company  
Contract NAS1-15003

wing box stiffness was designed to match that of the aluminum baseline, with no consideration of aeroelastic tailoring of the layup. Bending and torsional stiffnesses are also shown in Figures 3-5 and 3-6 at each wing station.

Member sizing was done at a preliminary design level, and considered effects of stringer height, stringer spacing, stiffening ratio, rib pitch, and ultimate strain. Figures 3-7 and 3-8 compare weights of the basic panels selected to match the aluminum stiffness with the baseline aluminum panels. The strength-only designs are at constant strain level. As can be seen, the maximum strain for the selected design at ultimate load is approximately 0.0055.

Based on this analysis, the thickness plot shown in Figure 3-3, and the skin panel weights summarized in Table 3-5 were developed. Other weights for the advanced composites design were estimated, based on preliminary sizing and comparisons to other studies. Optimization studies showed a relatively flat relation between weight and rib spacing in the range of interest, so that the rib spacing of the aluminum baseline was retained to allow the same systems interfaces to be used. Stiffener depth and spacing was matched to requirements at each station, and a balanced combination was selected to provide a constant height and distance between stringers for the entire panel in order to facilitate fabrication.

### 3.1.7 Design Assessment

As part of the design effort, and to support the development plan, an assessment was made of the major areas of the wing box that would require development support before a production commitment could be made. It is anticipated that extensive hardware development would be required to satisfy these needs:

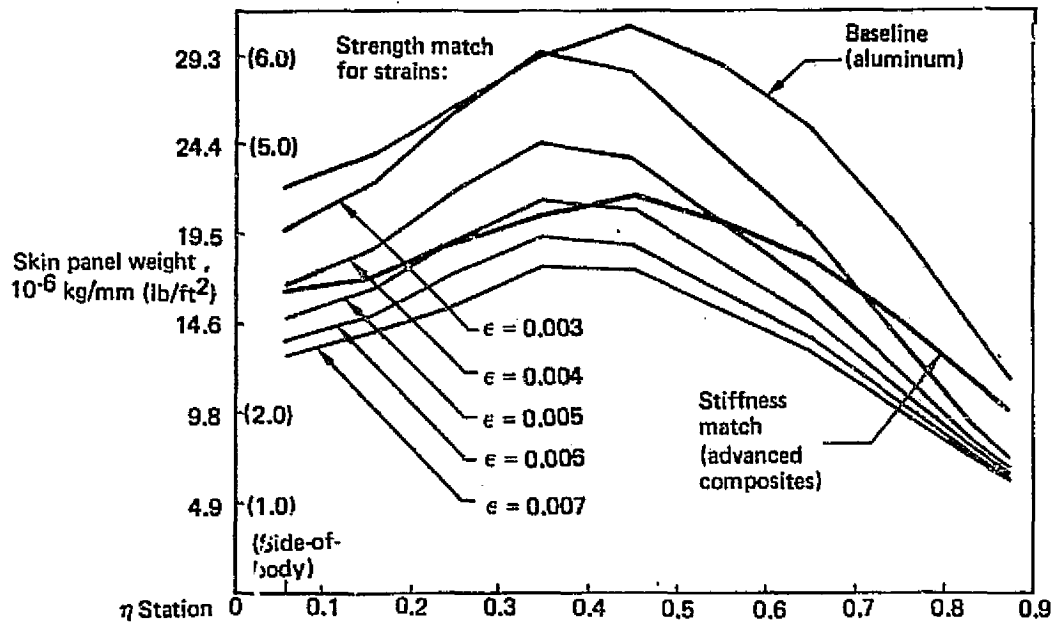

Figure 3-7 Wing Box Upper Panel Weights

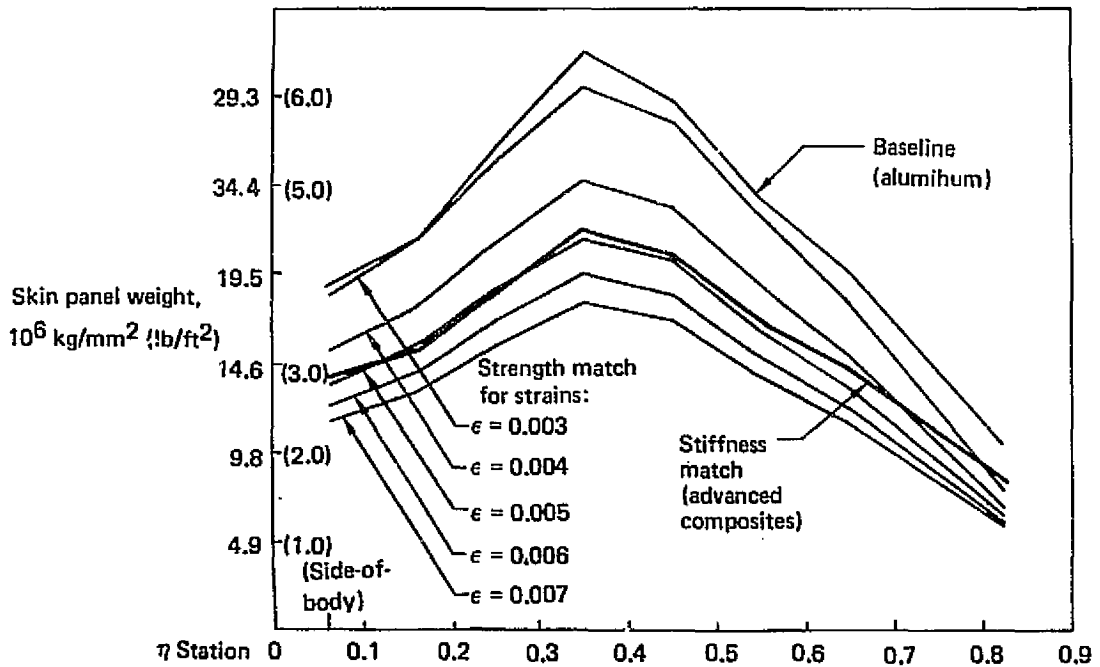

Figure 3-8 Wing Box Lower Panel Weights

Table 3-5 Wing Box Weight Comparison Summary

Description	Baseline aluminum weight, kg (lb)	Advanced composites concept weight, kg (lb)	Percent savings
Upper outboard panels	3 205 (7 060)	2 393 (5 270)	25.0
Lower outboard panels	3 051 (6 720)	2 134 (4 700)	30.0
Outboard ribs, spars	1 871 (4 120)	1 312 (2 890)	30.0
Center section fittings, installation hardware	1 730 (3 810)	1 348 (2 970)	22.0
	781 (1 720)	781 (1 720)	-
Total	10 638 (23 430)	7 968 (17 550)	25.0

- Cost-effective panel design—includes tension and compression panels, consideration of highly loaded areas to minimum gage; attachment to panels, access doors. Requires stability/allowable testing, manufacturing feasibility specimens, to support theoretical studies.
- Cost-effective substructure design—includes spars, ribs; similar programs to above with strong emphasis on manufacturing feasibility to support design studies.
- Panel splice design (tension and compression)—includes chordwise and spanwise splices; sweep break, special areas.
- Production splice location—includes impact assessment on assembly sequence, ability to tailor wing center section with advanced composites to meet fuel capacity, manufacturing, aeroelastic, and other design requirements.
- Stiffener runout design—tied in with cost effective panel design.
- Wing body attach method—considers both metal and advanced composites fuselage sections; includes thermal concerns.
- Fitting design—includes studies to consider metal, advanced composites major fittings.
- Concentrated load reaction—involves cost effective substructure design and fitting design; includes engine, landing gear, control surface, other chordwise loads.

Boeing Commercial  
Airplane Company  
Contract NAS1-15003

- System thermal compatibility—includes control cables, hydraulic lines, fuel lines.
- Lightning protection requirements—includes zone definition with protection requirements, burn-through in minimum gage and other areas, arcing, equipment interference.
- Grounding requirements, both lightning and fault—includes joint design.
- Fuel tank design—includes fuel/material interaction, drain location, minimization of unusable fuel.
- Fail-safe design requirements—strongly impacts splice location, panel design, joint and fitting design.
- Bonded joints, including rib panel, splices, final assembly— involves cost effective panel and substructure design, and panel splice design.
- Fastener policy definition—includes allowables, types, applications, sealing in tanks.
- Inspection criteria, including both in-process and flight service— affects hidden areas, access opening sizes, locations.
- Repair techniques, including in-process and flight service— affects part size, fastening method; should account for spares supply.

Boeing Commercial  
Airplane Company  
Contract NAS1-15003

- Surface protection, sealing—can affect outer layer layup, composition, edge details.

### 3.2 TECHNOLOGY ASSESSMENT

The first task was to conduct a comprehensive evaluation of all disciplines in the advanced composites field. The general approach used was to contact engineering technology personnel knowledgeable in a particular field, and obtain a subjective evaluation by asking questions. The questions were designed to supply the information needed to assess the current state-of-the-art, and existing plans for future technology development. Participating in the evaluation were personnel from Materials, Loads, Flutter, Stress, Weights, Fuels, Flight Controls, and Systems Technology groups. To assist in the evaluation, the baseline metal wing configuration described in Paragraph 3.1.2 was used. All evaluations were made relative to this wing box, which acted as a check and focal point to verify that all technology needs had been satisfied. This equivalent aluminum wing was used to establish many basic structural requirements for the advanced composites design. However, in many instances, the differences in material properties required a different treatment and approach. The identification of these differences constituted an important output of the study.

Additional study tools to assist in the evaluation were a draft master schedule that contained the essential elements of an advanced composites wing development plan, and a list of design requirements that were intended to reflect normal design practice; and two main references, the aluminum equivalent of the conceptual wing described above, and the draft of the FAA Advisory Circular, "Composite Aircraft Structures."

Results of the evaluation, which was conducted over a 2-mo period, included a listing of all key elements that must be considered prior to a production commitment decision. This list contained approximately 250 items, and proved useful in subsequent planning and costing activity. The current state-of-the-art review resulted in the identification of past and presently planned programs that contribute to today's technology base, with specific references, and what they have or will contribute. Sources of information included:

- NASA-ACEE and R&T programs
- Air Force and Navy programs
- Boeing IR&D and Product Division programs
- Industry IR&D
- General literature

The technology assessment activity necessarily generated extensive technical information in the form of lists, tables, and memoranda. It was obviously necessary to reduce the data into a more concise form, and give answers in terms of trends, priorities, and timing. One of the first observations in the search for critical technology was that disciplines, which were impacted most severely, were those influenced by a significant material property change or characteristics, or were affected by the manufacturing process. For example, the electrical resistance of graphite/epoxy material is about 1,000 times that of aluminum. This is a principal reason why electromagnetic effects have become a major technological concern, whereas loads analysis technology, primarily concerned with mass and stiffness of the structure, is relatively unaffected.

Results of this review, which are presented below, identify no new needs but, rather, reconfirm recognized areas of concern and identify the most critical technology needs from the perspective of the airframe manufacturer.

### 3.2.1 NASA/ACEE Program Contributions

The NASA/ACEE Advanced Composites program supports the design and manufacture of two airplane components by each of the three transport manufacturers, the FAA certification of those six components, and extensive flight experience by the airlines in scheduled service operations. The complexity of the applications increases in the secondary and medium-sized components leading to support for the advanced composites Wing program, which supplies much of the potential structure weight reduction. Wing box design requirements are different from those of the smaller component. The wing box is more highly stressed than secondary or empennage structure, and has additional design factors such as fuel containment and systems integration.

The ACEE empennage components will provide many significant contributions to the wing program. It has been estimated that the current programs will supply 50% of the basic material property data required for the wing design. Most of the process specifications and application guidelines will be applicable, as will developments in inspection and testing methods. Thus, the design and analysis of the current ACEE components will address many of the same questions the wing program will encounter.

In addition to specific technical benefits, the empennage programs have generated a nucleus of people with production hardware experience who can provide the basis for building the larger team required for wing design. The learning experience of the various groups is especially valuable in defining new interfaces made necessary by differences in the design, stress, manufacturing, and quality control methods used for advanced composites compared with metal technology. The continued success of the empennage programs will supply the practical experience element needed to confidently initiate the wing program.

### 3.2.2 DOD Contributions

First-generation commercial jet transports owed much of their technology heritage to an extensive fleet of large military airplanes. At Boeing, technology developments derived from the KC-135 program were a significant contribution in the commercial jet transport area. From today's perspective, it is apparent that military aviation developments have directly influenced the growth of the commercial aviation industry in both its production capabilities and its technology base.

Today, there is little possibility that the specific technology of a high-performance military airplane, designed as an integrated aerial weapons system, can be directly used by civil aviation to any appreciable extent, even though substantial benefits may later be derived from advances in aircraft production techniques. General technology developments, however, involve commonality in skills and knowledge, which results in a general transfer of technology within the industry and Government to meet the varying demands of civil and military aviation. For example, the recent AFML/AFFDL/AFOSR Joint Program Review for Mechanics of Composite Materials reported current programs involving moisture effects, fatigue, and fracture that obviously have direct application to commercial programs. The fact that the material systems are, in general, the same as those used in the commercial field is of great benefit.

Combat performance or the threat of technical obsolescence is usually dominant in military aircraft weapons systems. Thus, R&D for military equipment tends to provide early operational application in aeronautical weapons systems of advanced structures technology. When this occurs, it reduces the technical risks that would otherwise be encountered in applying the same technology to civil systems.

One of the main concerns at the time of a production commitment decision is the possibility of technical oversights (sometimes referred to as "unknown unknowns"). Because research programs are frequently constrained by contract or time limitations, a search for new problem areas may not be actively pursued. In the past few years, there have been many examples of military developments leading to the early identification of problems with new materials. The discovery by DOD research of embrittlement problems with some titanium alloys in a saline environment is an example of a valuable contribution made in titanium technology, as was the importance of the combined effect of temperature and moisture content on the glass transition temperature for advanced composites. Extensive technology development activity by the DOD plays a valuable part in reducing commercial program risk.

### 3.2.3 Technology Assessment Summary

The evaluation and reduction of the extensive data generated in the technology evaluation resulted in the identification of the most critical concerns and information needs for advanced composites wing development. Although no new needs were identified, the evaluation reconfirms already recognized areas requiring development, and presents priorities from the airplane manufacturers' point of view. This summary is presented and discussed in the Technology Development portion of the recommended program (Paragraph 4.1). A similar manufacturing assessment was conducted. The details are discussed in Paragraph 4.2.3, Production Development Plan.

SECTION 4.0

RECOMMENDED PROGRAM

With the conceptual wing design in hand and the various developmental needs identified by the technology assessment effort, an advanced composites wing program plan was prepared, consisting of three essential development elements:

- Technology
- Production capability
- Integration and validation

The program plan recognizes the study contract stipulation of " . . . providing to the commercial aircraft manufacturers, FAA, and the airlines the experience and confidence in advanced composites structure needed for extensive utilization of advanced composites structure in future commercial aircraft." The plan spans approximately 7 years, and can, at reasonable risk, lead to substantially improved commercial airplane efficiency.

The technology element is an extensive engineering development effort covering the following major concerns:

- Damage tolerance
- Durability/repeated loads
- Electromagnetic effects
- Environmental effects
- Material improvement

**PRECEDING PAGE BLANK NOT FILMED**

Production capability development is required in the following areas:

- Quality assurance
- Fabrication processes
- Assembly methods

The production capability development effort will use full-scale test hardware to validate production processes and obtain cost data. These are key factors in the acceptance of advanced composites material in airplane primary structure.

Integration and validation of technology development and production capability development will minimize production commitment risks, and can best be accomplished by design, fabrication, testing, and certification of full-scale, flight-worthy hardware. Four integration and validation options were chosen, costed, and evaluated.

There follows a presentation of the broad scope technology development and production capability development elements of the recommended program, and of the hardware option alternatives for development integration and validation. The sum of the effort recommended in each of these three elements is needed to arrive at a production commitment readiness with acceptable risk.

#### 4.1 TECHNOLOGY DEVELOPMENT

This section describes the technology developments needed for a production commitment.

#### 4.1.1 Damage Tolerance

For metal wing panels, design for damage tolerance basically involves limiting crack growth by the design of mechanically fastened stiffness and segmented skins, with the lower surface being critical.

With advanced composites, the material characteristics significantly change each of these aspects of damage tolerance. In addition to simple cracking modes, damage can take the form of crazing, delamination, or fiber failure, and can involve complex combinations of all modes. Boeing research has shown that, for tension design, local flaws such as delaminations show little significant growth when subjected to repeated loads. However, some tests have shown the importance of damage tolerance when designing compression structure. In fact the emphasis on the lower surface with metal designs has moved to the upper surface with advanced composites. The discrete mechanically fastened stringer design, which plays such a significant role in the metal designs in arresting damage growth, may not be cost-effective with advanced composites. It is essential, therefore, that efficient monolithic designs that have good durability and an inherent ability to contain damage be developed. These important differences between metal and advanced composites technology are reasons for placing damage tolerance among the most critical of technology needs. The prime reason is that the damage tolerance philosophy of design has achieved an excellent safety record with metal designs, and must be retained with advanced composites.

Damage tolerance requirements are divided into three categories: (1) undetectable flaws, (2) detectable damage, and (3) damage from an obvious discrete source. Structures with undetectable flaws resulting from manufacture or service must be able to withstand ultimate load and, therefore,

such flaws must be accounted for in regular static strength evaluation. Flaws also affect damage tolerance, in that they form starting points for propagation to detectable or critical damage size with repeated loads. All structure containing detectable damage must be capable of sustaining limit maneuver and gust loads. The size of the postulated damage must be based on initial detectability, and the damage growth rate under the repeated load spectra expected in service prior to detection by inspection. Damage growth, inspection, and residual strength are interdependent. To evaluate any one parameter, the other two must be considered.

Visual inspection plays a major role in real-world inspection procedures. Flaws that are below the visual level will probably be overlooked by normal inspections. To impose inspection procedures on the airlines that exceed visual requirement probably is not economically feasible. It is, therefore, pertinent that we identify and have the capability to design structure that will arrest flaws, and that will also tolerate and not be degraded significantly by flaws below the visual detection level. Aircraft inspection using unique NDI techniques has detected flaws below the visible level, but only those flaws that had been previously detected at a visual level created the information base for inspection of these so-called hot spots. With this inspection philosophy in mind, we then recognize the type of flaw tolerance we must develop.

The development of wing panels that have the ability to resist damage growth with repeated loads can be approached in several ways. Most of the advanced composites structures that have been designed to date operate at low strain levels and have been stiffness-critical, or have been secondary structure with no specific damage tolerance requirements. For the design of efficient commercial transport wings, however, higher design strain levels will make damage tolerance a prime constraint in the design. Panels

can be designed with damage-arresting zones along discrete narrow panel boundaries, which is similar to the concept used in metal panel design, or the panel might be designed for adequate damage tolerance or flaw-arresting capability by judicious material selection, laminate stacking, and panel cross section geometry. Each of the above types of damage tolerant design features must be reviewed to assess its suitability for particular wing panels.

The question of residual strength also poses several significant development tasks in two main areas. The first is the development and testing of the concepts, with residual strengths consistent with the inspection and damage growth rates; second is the development of analysis methods that can accurately predict residual strength.

Damage tolerance analysis method development is intimately connected with both material properties and the structural configuration. Therefore, developments must parallel design integration activity that introduces manufacturing constraints, and that defines coatings for ultraviolet radiation or lightning protection and other similar factors that could affect aspects of damage tolerance evaluation. With metal design relatively simple, fracture mechanics technology can determine critical crack lengths with reasonable accuracy by using well-behaved and predictable material property data. For advanced composites, however, there is a wide variety of possible damage combinations. For the compression surface, this variety can involve instability at both the micro and macro level that must be accounted for in combination with environmental effects, including temperature and the moisture content. For example, some failure modes could be critical at low temperature where there is increased brittleness, while others could be critical at elevated temperatures where basic mechanical properties are reduced.

Critical elements of damage tolerance design that must be developed are:

- An understanding and characterization of damage types and propagation of damage
- Service inspection methods consistent with the structural configuration, operating stress levels, and residual strength of the design
- Quantitative evaluation of real-world environmental effects that influence aspects of damage tolerance
- A methodology that can accurately determine critical damage, taking into account the various damage types and combinations of damage in the several different possible failure modes
- Identification of proof of structure options, with an overall plan for accounting for temperature and moisture effects

#### 4.1.2 Durability/Repeated Loads

A potential for improved fatigue performance and reduction of weight resulting from reduced fatigue constraint are benefits expected from the use of advanced composites. However, like metal designs, advanced composites structure will develop cracks or other degradations with repeated loads, and reliable durability analysis methods are essential to ensure that the fleet is economical to operate. Existing fatigue data on simple panels indicate certain departures from metal behavior, in that mean stress does not play such a significant role in determining life, but the magnitude of both the alternating and maximum stresses is more important. Although these trends were obtained from simple test specimens, the effect of other detail geometries is anticipated to show a similar behavior. As with damage tolerance, the complex nature of failure modes increases the difficulty of damage definition, initial detection of failure, and interpretation

of test results. The current ACEE programs will address some aspects of these problems, but additional effort will be required to completely characterize material durability.

Metal experience has shown that over 50% of all fatigue problems are associated with poor detail design, and it is anticipated that this will also be true for advanced composites. Of prime concern, in addition to the basic material properties, is the application and the evaluation of design details.

When the data base for constant amplitude testing has been established, a definitive damage rule must be developed for advanced composites structure to provide a correlation between constant amplitude cyclic testing and spectrum testing. This correlation is essential for design, because it will be neither technically nor economically feasible to evaluate all advanced composites details by spectrum tests. Miner's rule, with certain modifications, has proved effective in the fatigue analysis of current Boeing metal aircraft structure. The development of an equivalent method for assessing cumulative damage is needed for the design of commercial aircraft structure using advanced composites. It is anticipated that such a correlation is possible, by certain modifications to existing cumulative damage analysis methods.

However, extensive testing will be required to develop the data base needed to establish and validate the method. Major additional effort is required to incorporate environmental effects, to assess the combined effects of repeated loads and temperature, moisture content, and other degrading influences. The scale-up methodology that will be generated will be vital in the interpretation of major fatigue tests that will be conducted at ambient temperature.

The critical elements for durability/repeated loads technology are?

- An analysis and test methodology that establishes the material data base
- Verification of actual design details that will be used in the wing
- Development of a test-validated accumulative damage analysis method
- Quantification of the combined effect of the environment and repeated loads

#### 4.1.3 Electromagnetics Technology-Lightning Protection

Test results reported in the industry indicate that attachment damage criteria for the conventional three lightning zones will hold true for large graphite/epoxy structures such as a transport aircraft wing. As a result of Boeing work on Air Force contracts, the protection level requirements for attachment damage are well established, but additional effort is required to improve the protection systems themselves. All present protection systems and conductive materials require local repair after major lightning strike. High-current testing has shown that a reasonable cross sectional area of graphite/epoxy structure can carry lightning currents without damage, but the development of electrically conductive joints that will resist damage is a significant development item.

The most critical area of electromagnetics technology is fuel ignition. Any internal sparking in a fuel area is a probably ignition source. Therefore, it must be prevented from occurring. Furthermore, arcing and streamer-ing must also be prevented in the vicinity of fuel vent outlets, or other areas where fuel vapors may be present in an ignitable mixture.

Boeing Commercial  
Airplane Company  
Contract NAS1-15003

It has been established that 0.203-cm (0.080-in) aluminum alloy skin thickness is adequate to prevent hazardous inner-surface heating and penetration on smooth surfaces of a metal wing. Penetration criteria for advanced composites structure can be expected to depend not only on material thickness, but also on material type and conductivity, presence of embedded conductive materials, and/or thickness and conductivity of any coatings. While the Boeing/Air Force lightning strike investigation has concentrated almost exclusively on attachment damage protection, test results on a number of samples that incorporated joints between their several parts served to highlight the potential seriousness of the fuel ignition problem in advanced composites structure. These test results showed that arcing and sparking occurred on all of the advanced composites joints designed and built for the contract. Research should be initiated at the earliest possible date, in order to determine if and to what extent this technology area will pace the advanced composites wing development.

The lightning current pulse passing through the airplane wing generates a magnetic field that induces a voltage transient on wires and cables. Circuit driving sources and loads must be able to withstand these transients without damage or significant upset. Traditional protection techniques (such as transient limiters, filters, and shielding) depend on the nearly equipotential ground plane and Faraday cage, which are afforded by conventional structure. Development of new protection techniques and criteria will be a required element of the wing development program.

The Navy/Boeing electromagnetics contract, and industry reported data, have determined that antenna ground-plane performance will pose no problems. Also, electrical isolation aspects of antenna technology are similar to those discussed under electromagnetic field shielding.

Boeing Commercial  
Airplane Company  
Contract NAS1-15003

An equipotential ground plane wrapped around into a Faraday cage is the most important single contribution the conventional riveted aluminum structure makes to avionics/electrical systems. New techniques for achieving a ground reference for signal transmission in engine and flight control systems will need to be developed. Interface circuits for electrical/electronic systems are defined as the signal source in one black box, the load or receptor in another black box, and the interconnecting wire or cable.

The level of interface circuit immunity must be increased to cope with the more severe electromagnetic environment resulting from the reduced shielding effectiveness of advanced composites. Not only will lightning induced transient levels increase, but so will electromagnetic interference from other circuits, equipment, and antennas.

It has been standard practice in the aircraft industry to use the conventional aluminum airframe as a "ground return" circuit for the ac and dc electrical systems. This practice saves hundreds of pounds of wire weight and associated costs in jet aircraft. The degree to which these savings can be realized with advanced composites structure depends upon the resistivity of the advanced composites materials, and electrical bonding feasibility. An increase in ground return resistance will result in an increase in a single-phase ac and dc impedance of the total circuit. Circuit impedance is a critical factor, and must be small enough to not adversely affect system performance.

The primary electromagnetic threat to the electrical power system, just as with signal transmission circuits, arises from voltages induced in the aircraft wiring. The induced voltages are conducted to power system control units that contain solid state circuits performing logic, protection, and

regulatory functions. Voltages induced in wiring are also conducted to the input terminals of electrical power utilization equipment. Induced voltage levels exceeding design limits on the equipment can cause many adverse effects.

The shielding properties of structure are directly related to the conductivity of structural materials and the electrical continuity between structural components. The most pressing need in this area is development of the analytic tools to determine the electrical characteristics of a structural component from the laminate configuration and layup geometry. With this means of evaluating a design, electrical conductivity and shielding design allowables could be established. Marked changes in grounding criteria for wire and cable shields, wire bundle categorization procedures, and wire bundle separation criteria are expected with major application of advanced composites.

#### 4.1.4 Environmental Effects

It is well known that absorbed moisture will affect the mechanical properties of graphite/epoxy laminates at elevated temperatures. Since aircraft components are exposed to atmospheric moisture, rain, and accumulated water, quantitative data are required showing the amount of fluids absorbed under various environmental conditions, and the effect of this absorption on mechanical properties. Among the parameters to be investigated are: geographic location, flight profiles, solar heating effects, ultraviolet degradation, retrieval times, specimen types, and test temperatures. A current NASA/Boeing experimental program includes in-flight and ground exposure to obtain mechanical, physical, and chemical data. This program is designed to supply most of the field data required for the extensive use of advanced composites material. The development of analysis methods must

include the correlation of environmental degradation with strength, damage tolerance, and fatigue properties of the material.

The key, then, is to quantify the degradation of the material properties so that we are able to predict how the material will react to both long-term and short-term exposure to these effects. Understanding what these effects are, and defining them as we currently do with static design loads and the fatigue spectrum experienced by the aircraft, are necessary if we are to satisfy all our management and certification questions concerning environmental effects on these materials. The important aspect of this definitive characterization of materials is the ability to select and/or tailor material improvements required for resistance to these environmental effects. A critical need is the ability of the industry to take pieces of information of various areas and combine them in a methodology that will truly define the effects of more than one environment on structure, and determine the effects of these combined environments on the full-scale hardware, as illustrated in Figure 4-1.

These scale-up effects are extremely important to the commercial transport industry, because the large size of commercial aircraft makes it economically impossible to environmentally test full-scale wing components. The ability to scale data from coupons and subcomponent testing is, therefore, essential. Although each segment of the industry has begun its own effort in this area, it is important enough to be recognized as a major technology need.

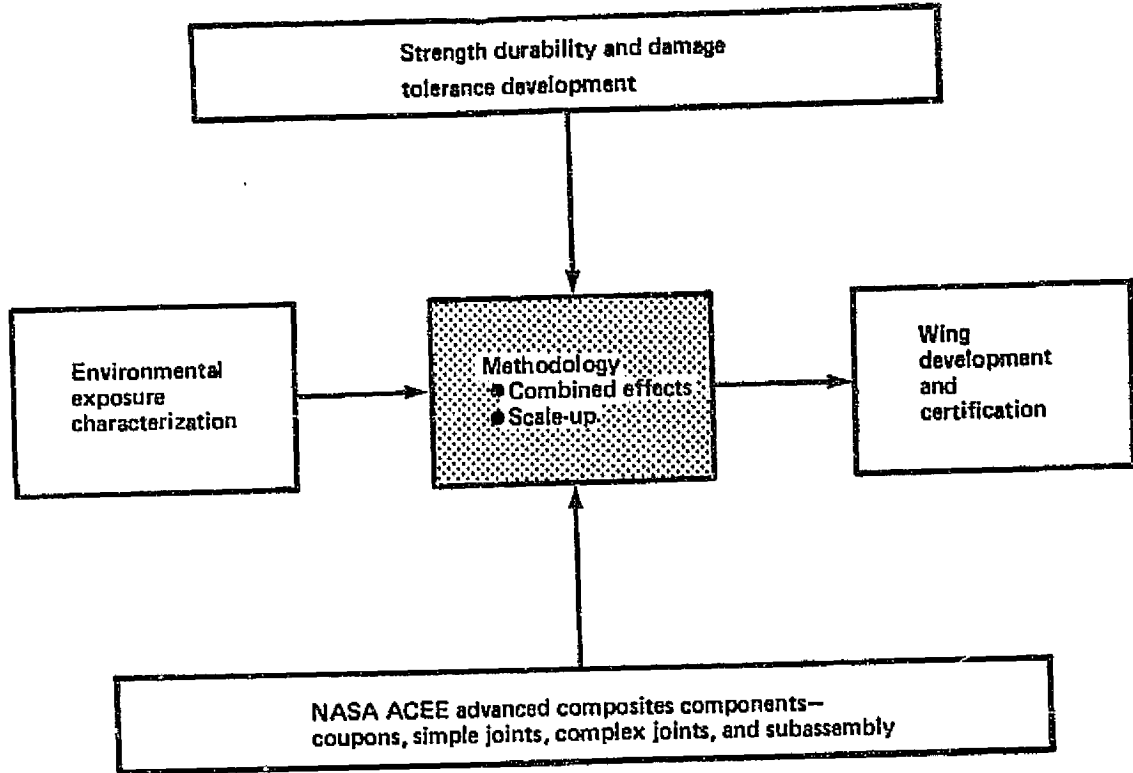

Figure 4-1 Development of Environmental Effects Technology

#### 4.1.5 Material Improvement

There is a consensus within the commercial aircraft segment of the industry that material improvement is necessary prior to the extensive commitment of advanced composites to primary structure. Specific properties that should be improved are:

- Toughness
- Resistance to the environment
- Cost effectiveness
- Fiber containment

It is seen that this list does not contain the basic material strength properties that are considered adequate to achieve weight saving goals, but the list does contain the factors that are considered to be the principal constraints on the design. When any one property is improved, other properties are affected. It is not only necessary to identify what needs to be improved but also to quantify or clearly define all engineering and manufacturing requirements for any new material system, so that each can be monitored to ensure an accurate overall evaluation. Once the new material requirements are defined, quality assurance methods and procedures must be made available to ensure the repeatability of producing and processing the material. This aspect of quality control can provide an element of material improvement by ensuring material consistency. Inherent in the material's characteristics must be its long-term durability. Therefore, quality assurance is an essential part of assuring both engineering and management that the material's systems will remain unchanged.

Boeing Commercial  
Airplane Company  
Contract NAS1-15003

In addition, engineering must cooperate with manufacturing. Each must be ready to compromise its needs, and understand the needs of the other. The material selected must not only meet all the engineering structural requirements but must also have process ease and flexibility to improve the quality of the product and to reduce costs.

An area that has been identified as a key in the evaluation is the sensitivity to damage tolerance of the material, as well as the configuration effects. The current materials being utilized by the industry in general have resin systems that exhibit brittle characteristics. Therefore, the configuration of the structure alone may not be sufficient to provide damage tolerance.

The critical elements for the material improvement development are then:

- Definition and quantification of engineering and manufacturing requirements, so that evaluation can be monitored
- Achievement of improvements in material toughness, resistance to the environment, cost effectiveness, and fiber containment
- Investigation of hybrids, thermoplastics, and formulation

Boeing Commercial  
Airplane Company  
Contract NAS1-15003

#### 4.1.6 Other Concerns

Associated Materials - The use of advanced composites material in aircraft wing structure involves integration with the technology of other material, and affects interfaces with other materials. These technology areas encompass adhesives, corrosion protection, sealants, materials involved in lightning protection, and chemical/thermo/physical control.

Present commercially available 350<sup>o</sup>F cure adhesives have demonstrated the capability to bond graphite/epoxy components in secondary bonding processes. The initial unexposed bonds exhibit strength in excess of 3,500 psi overlap shear, which is comparable to values obtained in structural metal-to-metal assemblies. The major technology concern for adhesives in secondary bond operations is environmental durability. Very little data exist with respect to advanced composites bonding, and the stability of adhesive bonds under combined temperature/contaminant/stress/time exposure. Moisture is considered the most degrading medium on bond strength. However, effects of fuels and fluids must also be investigated to ensure long-term bond structural integrity. The large variance of thermal expansion characteristics between graphite/epoxy advanced composites and aluminum alloys may restrict use of such alloys in 350<sup>o</sup>F bonding, to ensure stress-free structures. Titanium and steel alloys are the most compatible with advanced composites expansion properties. Current surface preparation techniques for these metals are considered adequate, but not as good as those that have been developed for epoxy/aluminum bond surface preparation. Major concern for this technology is again in the durability of composite-to-metal bond in a long-time moisture, fuels, and fluids exposure. Additional work on surface preparations for titanium and steel alloys could significantly improve bond strengths.

Boeing Commercial  
Airplane Company  
Contract NAS1-15003

Also of concern in the use of large graphite/epoxy structure is the galvanic corrosion of adjacent aluminum alloy components. Exposed advanced composites and aluminum, in the presence of contaminated moisture as a conducting medium, can cause significant corrosion to the aluminum. The protective measure currently used for design specifies electrical isolation of graphite/epoxy and aluminum structure. Present programs are being conducted to determine the severity of this problem, and the protective measures required. Lightning protection systems that are being developed incorporate a thin aluminum screen, or employ flame spray or foil on the advanced composites surface.

How corrosion protection measures involving isolation can be meshed with the electrical continuity requirements for lightning current flow has not been resolved.

Data available at present are insufficient to scope the effectiveness of sealants used with advanced composites structure. Two potential problems that are of concern are the ability of commercial sealants to contain fuel using standard sealing techniques, and the possible diffusion of fuel through advanced composites laminate wing structure. In addition, the durability of the sealant-to-composite bond has not been established.

Crashworthiness - The crashworthiness of advanced composites primary structure is often seen as a concern, because with standard coupon specimens the energy absorbed at failure is less than that with aluminum alloys. However, the primary means of achieving a safe design in an emergency landing are just as applicable to advanced composites as they are to metal structures. Those methods include criteria for fuel containment in an emergency landing, where the local wing box structure at the attachment of flaps, control surfaces, nacelles, and landing gear is designed to sustain more load than would be required to separate any of these components from the wing. Configuration control is another primary means of retaining fuel tank integrity, by reducing the risk of possible penetration of the fuel tank. Although ductile materials do absorb more energy at failure, the energy involved at the point of failure of a large structure is small compared with the total energy involved. This is demonstrated in the ultimate load tests of metal wings, which usually give very small indication of strain nonlinearity before failure.

Thus, with careful attention to configuration and design criteria, it is anticipated that primary wing structure fabricated from advanced composites will have the same high level of safety as an aluminum alloy structure. However, development and testing in this area is needed to assure management and regulatory agencies that equal passenger protection can be obtained with advanced composites.

Repair - Techniques must be developed for performing high-quality repairs suitable for primary structure. The methods must recognize the significant real-world repair constraints imposed by an in-service environment. They must allow for the many different forms that damage can take in advanced composites structure, including failure of the matrix, broken fibers, delaminations, cracks parallel to and in-plane with the fiber, and combinations of these. In addition, the structural integrity of all repairs must be verified by analysis and test.

Boeing Commercial  
Airplane Company  
Contract NAS1-15003

#### 4.2 PRODUCTION CAPABILITY DEVELOPMENT

This section describes the production capability development that is required for a production commitment. The production plan, tooling concepts, production facility equipment requirements, and process development plans are elements of production capability development. These elements were planned with the cost target of competitiveness with aluminum wing structure as the major goal.

The approach to production capability development involved four integrated efforts; 1) working with engineering in designing wing structural concepts that are producible and inspectable, 2) preparing a production plan, 3) establishing a tooling and facilities plan, and 4) planning the process developments that are required to make a production commitment.

The close tie between engineering, manufacturing, and quality assurance was essential in developing cost-effective wing design concepts. Cost/productivity studies were performed to identify the basic wing breakdown, and to select design concepts for major wing components.

A production plan was prepared using the structural concepts that were developed during the manufacturing/design interface. The completed production plan was then used to prepare the tooling/facilities and process development plans.

##### 4.2.1 Production Plan

The production plan was prepared to establish manufacturing and quality assurance needs.

Initially, different production methods were evaluated for each wing structural concept. Cost trade studies were then performed to select the most cost-effective approaches to fabricating the major wing components. The selected approach also had to:

- Be production-ready by 1985
- Support a production rate of eight airplanes per month
- Have a back-up fabrication technique

A production flow was prepared to identify significant requirements for each manufacturing approach.

The following provides results of the cost trade studies and production flow for the major wing manufacturing operations. These operations include spar fabrication, rib fabrication, panel fabrication, and wing assembly.

Spar Fabrication - The front and rear wing spars' design (see Paragraph 3.1.4) presented some unique manufacturing problems, due to their 29.38-m (80-ft) length and a cross section that tapers from approximately 127 cm (50 in) to 25.40 cm (10 in). The processes that were evaluated for fabricating the spars, and the respective relative cost are listed below:

<u>Production Process</u>	<u>Relative Costs</u>
● Hand layup-autoclave cure	1.0
● Hand layup-elastomeric aided autoclave cure	1.0
● Hand layup-captive elastomeric mold-oven cure	0.9
● Mechanized layup-diaphragm press-mold cure	0.7

<u>Production Process</u>	<u>Relative Costs</u>
● Thermoplastic molding	0.9
● Filament winding-elastomeric aid to autoclave cure	0.7

Filament winding-elastomeric aided autoclave cured provided the lowest cost and risk process. Mechanized layup-diaphragm press-mold cure was too high a risk process for fabricating the spars. A high rejection rate due to wrinkles in the radii was anticipated during the diaphragm press molding. Hand layup-elastomeric aided autoclave cure will be a back-up process to filament winding the spars.

The filament winding process involves the winding of four spars on a single mandrel. Then the four spar windings are slit. The slit spar devices are transferred individually from the mandrel, and placed into a female curing mold with elastomeric tooling pressure aids. After autoclave curing, the spar is inspected and edge-trimmed using an automated router. Figure 4-2 depicts the spar detail fabrication flow.

Product quality will be closely monitored throughout the manufacturing of the spars. Mechanized methods (Figure 4-3) such as resin chemical analysis and fiber quality analysis for receiving inspection in-process adaptive control and cure monitoring will be utilized to ensure quality and reduce costs.

Rib Fabrication - Honeycomb, truss, and solid laminate rib designs were evaluated during the study. The solid laminate configuration described in Paragraph 3.1.4 was selected as the most producible design. The production processes and relative costs that were studied for this component are as follows:

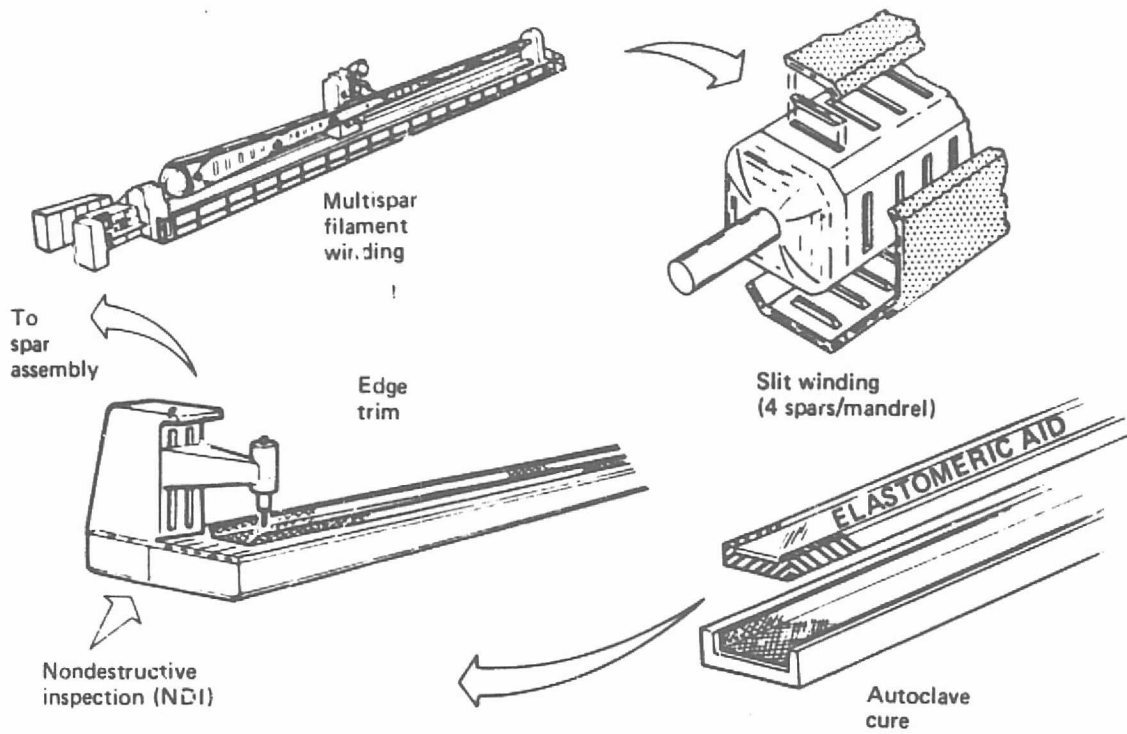

Figure 4-2 Spar Detail Fabrication Flow

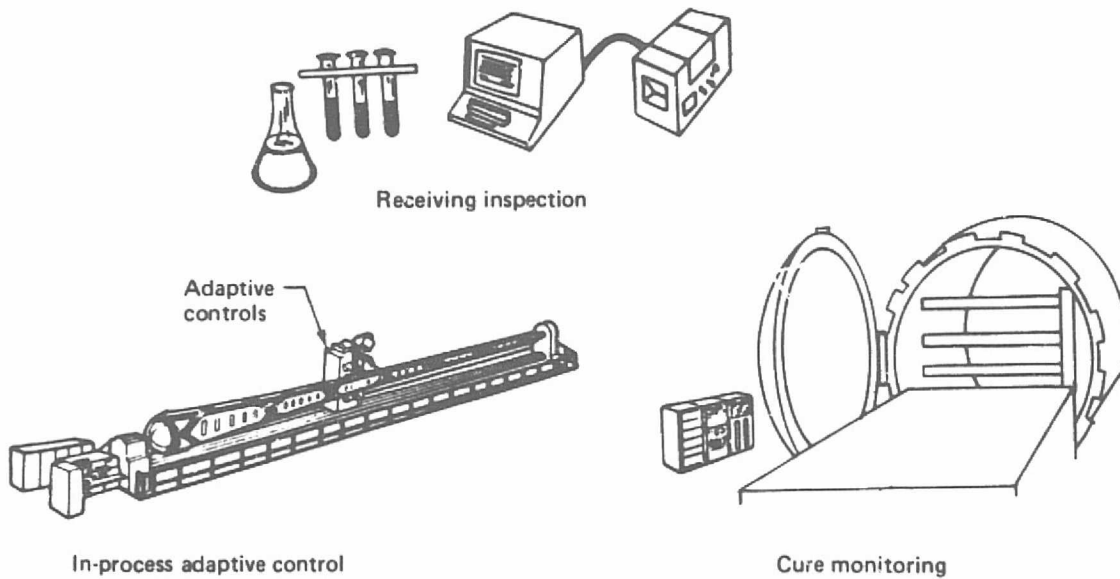

Figure 4-3 Production Quality Assurance

<u>Production Process</u>	<u>Relative Costs</u>
● Hand layup-autoclave cure	1.0
● Hand layup-elastomeric aided autoclave cure	0.9
● Hand layup-captive elastomeric- autoclave cure	0.9
● Filament wind-autoclave cure	0.8
● Mechanized kitting-elastomeric die molding/cure	0.7
● Compression molding	0.7

Mechanized kitting-elastomeric die molding/cure was selected as the lowest cost and risk process for producing the ribs. Compression molding will not provide ribs with adequate strength for use on the wing. Hand layup-elastomeric aided autoclave cure will be used as the back-up process for elastomeric die molding.

The elastomeric die molding process is illustrated in Figure 4-4. An automated kitting machine (Figure 4-5), will be used to cut cloth for the ribs. These will be hand loaded on a heated male die and press cured using an elastomeric rubber female die to provide pressure distribution and conformity. Several of the inboard wing ribs are too large to mold in a press. These ribs will be hand laid and autoclave cured. After cure, the ribs will be nondestructively inspected and trimmed using an automated router.

Skin Panel Fabrication - The skin panels are the largest and most complex basic structures of the wing box. These panels were evaluated and a trace study was conducted to determine the most producible manufacturing approach: 1) manual fabrication of the skins, stiffeners, and closure layers, and 2) automated layup of the skin and closure layers, and pultrusion of the stiffeners. The automated processes were selected, based on cost. The manual processing was two times more costly than the automated processes.

Automated  
rib kitting  
machine

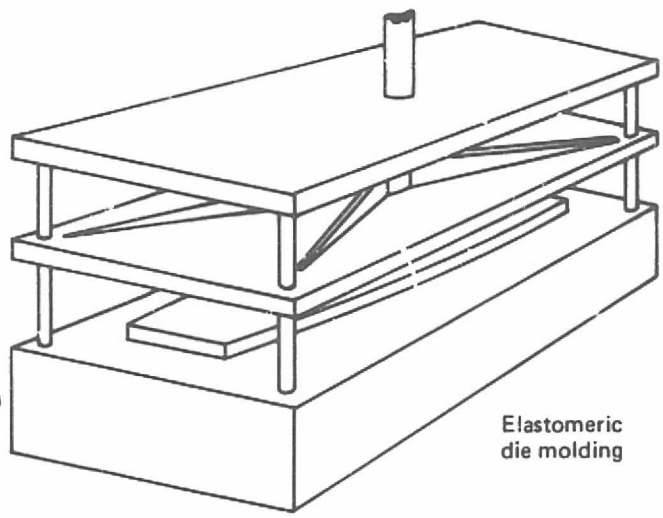

Elastomeric  
die molding

Nondestructive  
inspection  
(NDI)

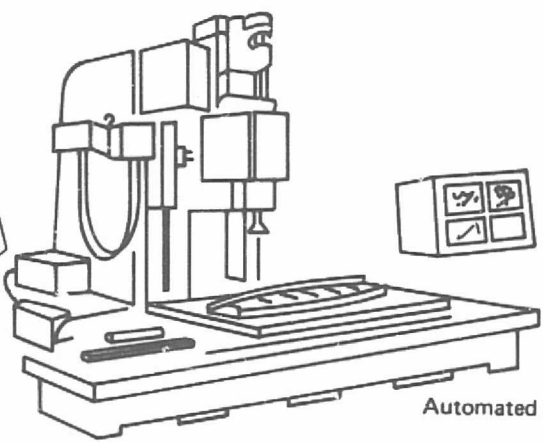

Automated machine trim

Figure 4-4 Rib Fabrication Flow

Boeing Commercial  
Airplane Company  
Contract NAS1-15003

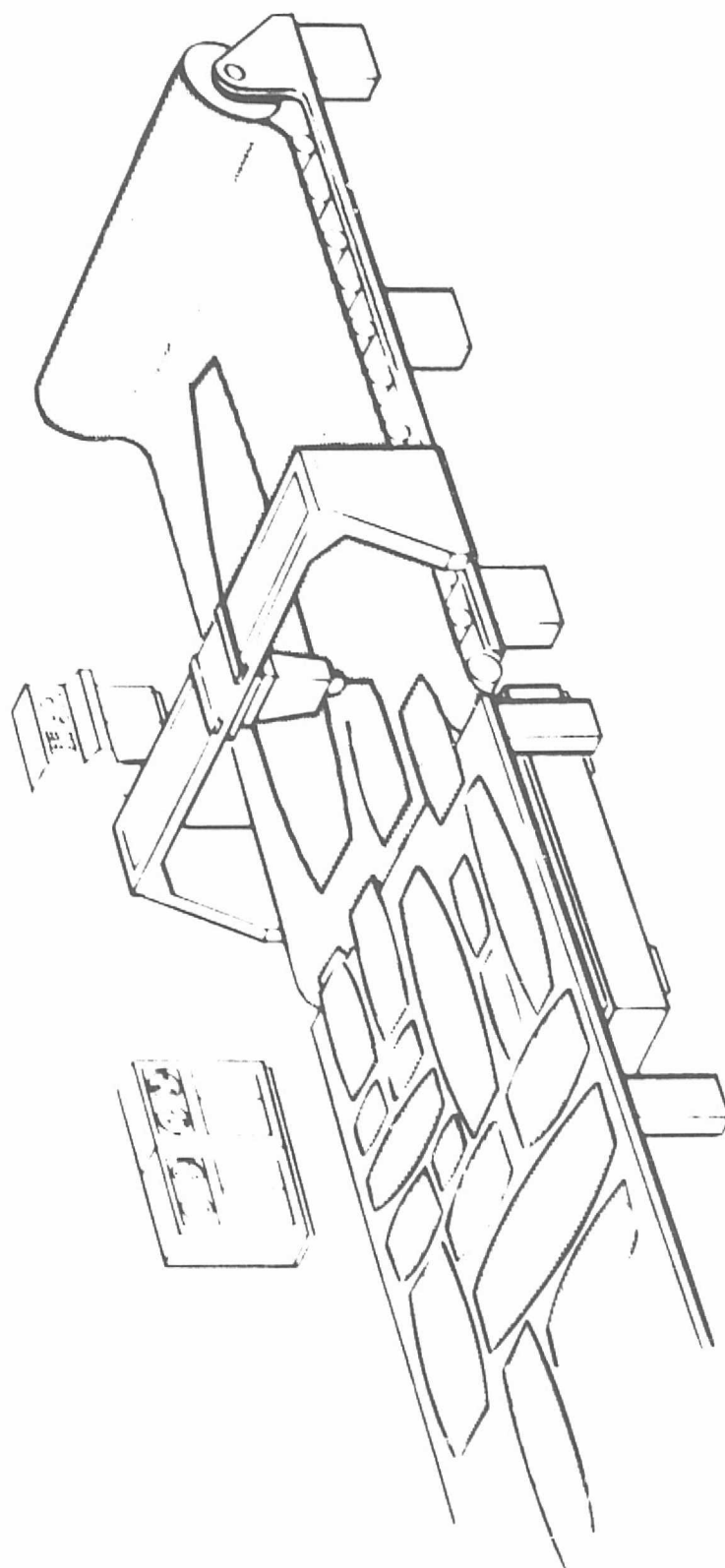

Figure 4-5 Mechanized Kitting

Boeing Commercial  
Airplane Company  
Contract NAS1-15003

The panel fabrication process involves automated layup of the basic skin, followed by autoclave cure nondestructive inspection. The stiffener will be pultruded as a plank and then slit into stiffeners.

These will be positioned on the cured skin, and the closure layers automatically laid to tie the stiffeners to the basic skin. After autoclave cure, the panel will be reinspected and trimmed on an automated router.

Automated layup, pultrusion, and ultrasonic through-transmission inspection, (Figure 4-6) are the significant processes that will be employed to produce and inspect the skin panels. As illustrated in Figure 4-7, two skin panels will be laidup simultaneously. This will be done on a contoured, graphite/epoxy mold that also will be used during autoclave cure.

Wing Assembly - The advanced composites wing design concept has many of the same assembly sequence, tooling, and methods requirements as today's metal designs. For this reason, the wing assembly will closely resemble that used for current commercial airplane production wings. Although the overall approach involves mechanically fastening of ribs, spars, and skin cover panels, an initial engineering design also required assembly bonding of the skin cover panels to the spars. This approach was evaluated and compared to mechanically fastening only. The cost trade of these two alternatives revealed that assembly bonding would add an estimated 20% to the overall assembly costs. Mechanically fastening only was selected as the assembly method.

The spars and ribs are joined initially, then the wing cover panels are fastened to this understructure to complete the structural box. Sealing and systems installations, as well as leading- and trailing-edge secondary structure work, will follow completion of the basic box. Both the spars and

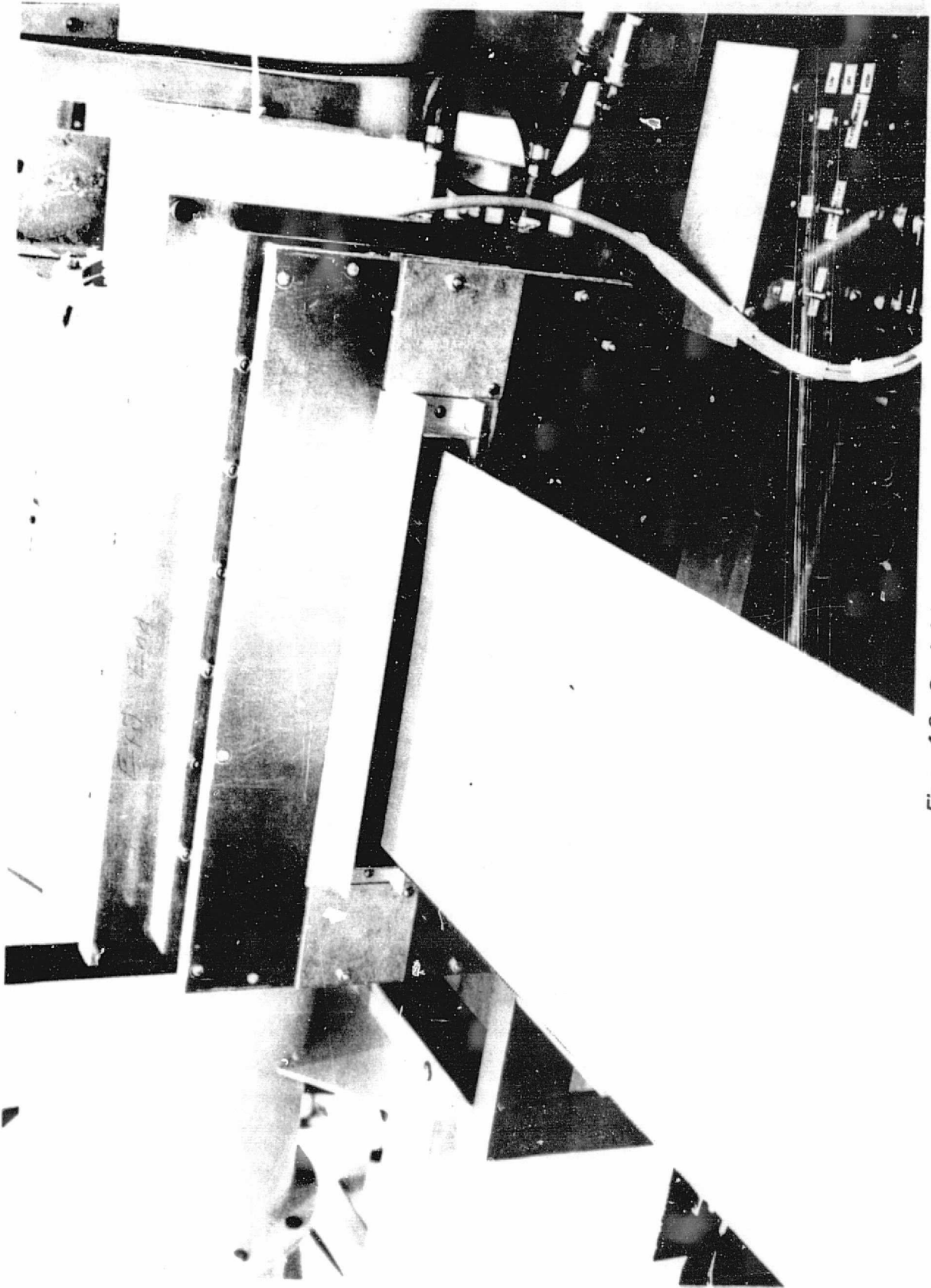

Figure 4-6 Sandwich Pultrusion

Boeing Commercial  
Airplane Company  
Contract NAS1-15003

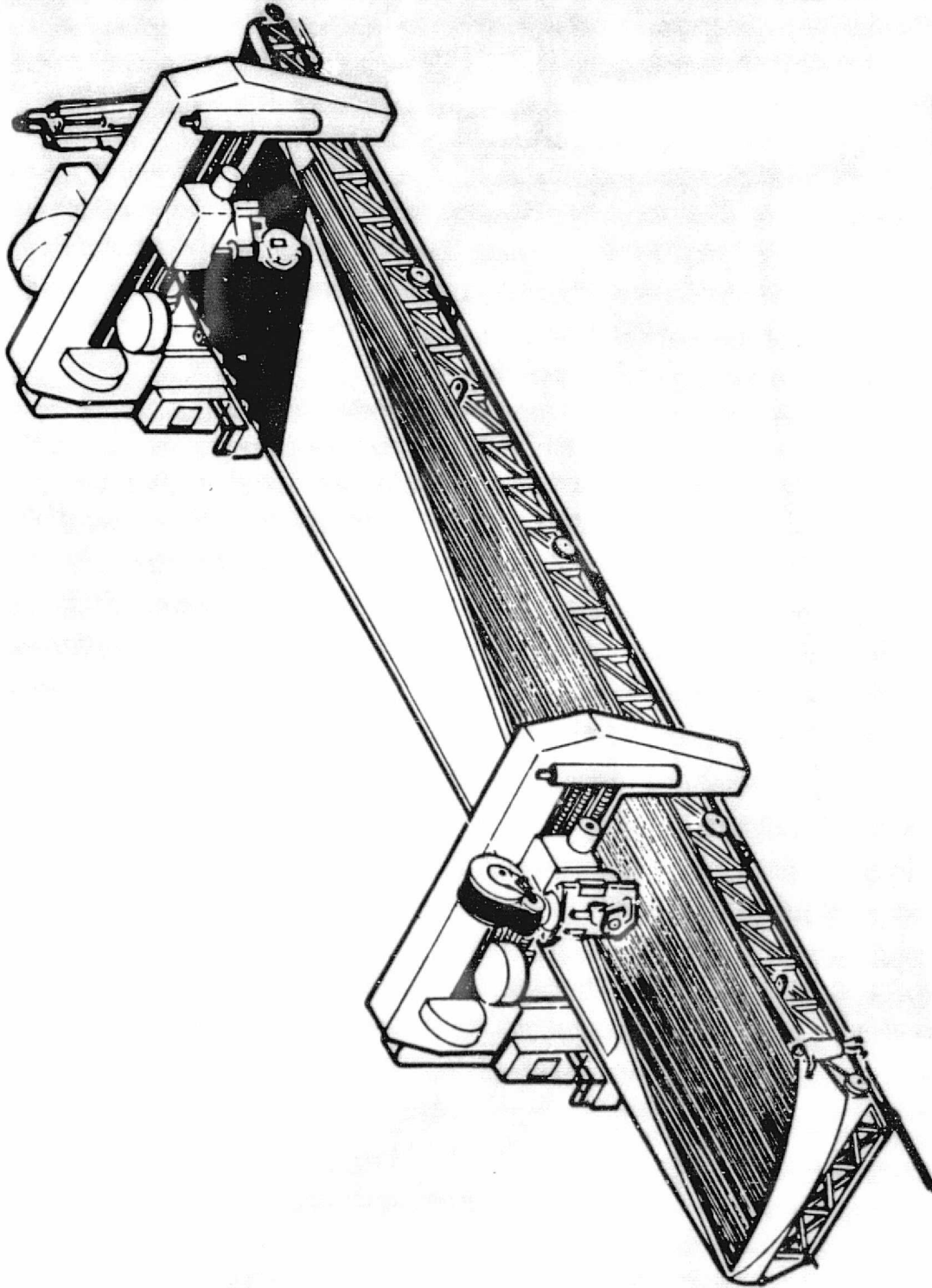

Figure 4-7 Automated Layout Machine

ORIGINAL PAGE IS  
OF POOR QUALITY

Boeing Commercial  
Airplane Company  
Contract NAS1-15003

ribs require mechanical attachment of clips, angles, brackets, and fittings. These items will be drilled and fastened using the automated assembly machine shown in Figure 4-8.

Production Needs - In summary, the following major needs were identified from the production plan:

- Automated inspection method
- Mechanized fabrication, such as filament winding, pultrusion, and automated layup
- Automated assembly methods

These needs were used in preparing the tooling, facility, and process development plans.

#### 4.2.2 Tooling/Facility Plan

The production plan provided the basis for preparation of the tooling and facility plan. Each manufacturing process was analyzed for tooling and facilities requirements.

Tooling Concepts - The large-part sizes and handling problems were areas that required consideration from a tooling standpoint. Development of tool design and fabrication techniques will be required for master models, layup molds, (especially graphite/epoxy molds), filament winding mandrels, and inspection tools. Tolerances, thermal expansion differences, mating surface control, tool coordination, and substructure stability are important factors that must be established for these types of tools.

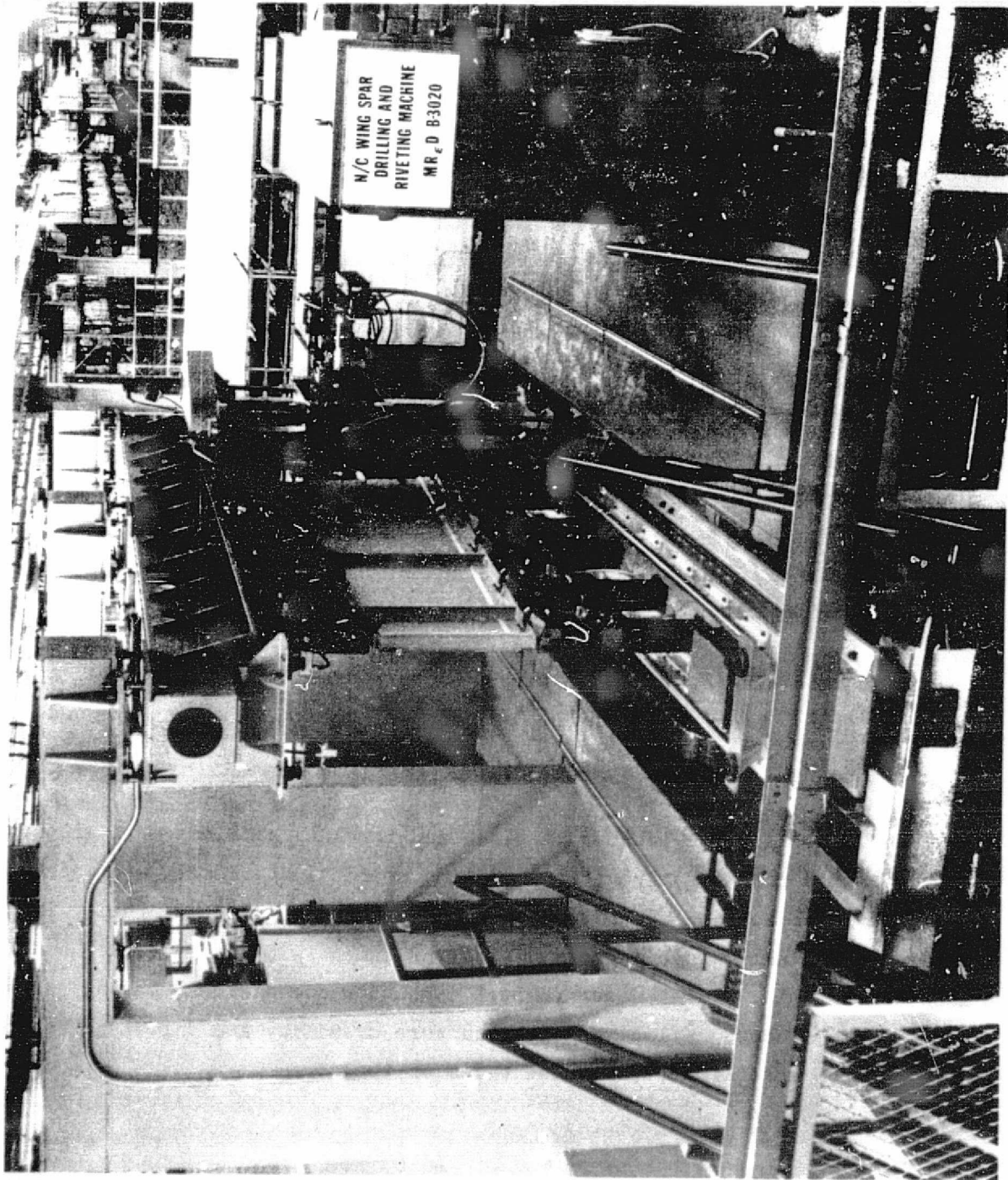

Figure 4-8 Automated Assembly Machine

ORIGINAL PAGE IS  
OF POOR QUALITY

Boeing Commercial  
Airplane Company  
Contract NAS1-15003

Facility Requirements - The major production capital equipment required for component fabrication are as follows:

- Autoclave-38.1 m x 6.1 m (125 ft x 20 ft) diameter, air heated
- Filament winding machine-computer controlled, 24.4 m (80 ft)
- Automated layup machine-4-axis computer controlled
- Elastomeric die molding presses-272 154 kg (300 ton) and 544 308 kg (600 ton)
- Pultrusion unit with in-process inspection
- Automated prepreg cutting machine-computer controlled
- Automated trimming machines
- Quality Assurance-receiving and final inspection

An automated assembly machine and portable drilling/fastening equipment are the capital equipment items needed for production assembly.

A floor plan layout of a building for component fabrication is shown in Figure 4-9. This building would be a new facility, dedicated to wing fabrication, and would be required to support the eight airplanes per month production rate. Assembly can be accomplished in an existing building, Figure 4-10. An area of 11 706 m<sup>2</sup> (126 000 ft<sup>2</sup>) would be needed for spar and major wing assembly.

The existing component fabrication and assembly facilities are adequate to support the Option C (see Paragraph 4.3.4) and process verification developmental efforts. Current facility plans show over 9940 m<sup>2</sup> (107 000 ft<sup>2</sup>) of floor space will be available for advanced composites fabrication or joint use by advanced composites fabrication and associated production.

#### 4.2.3 Production Development Plan

The production plan identified the following major development needs:

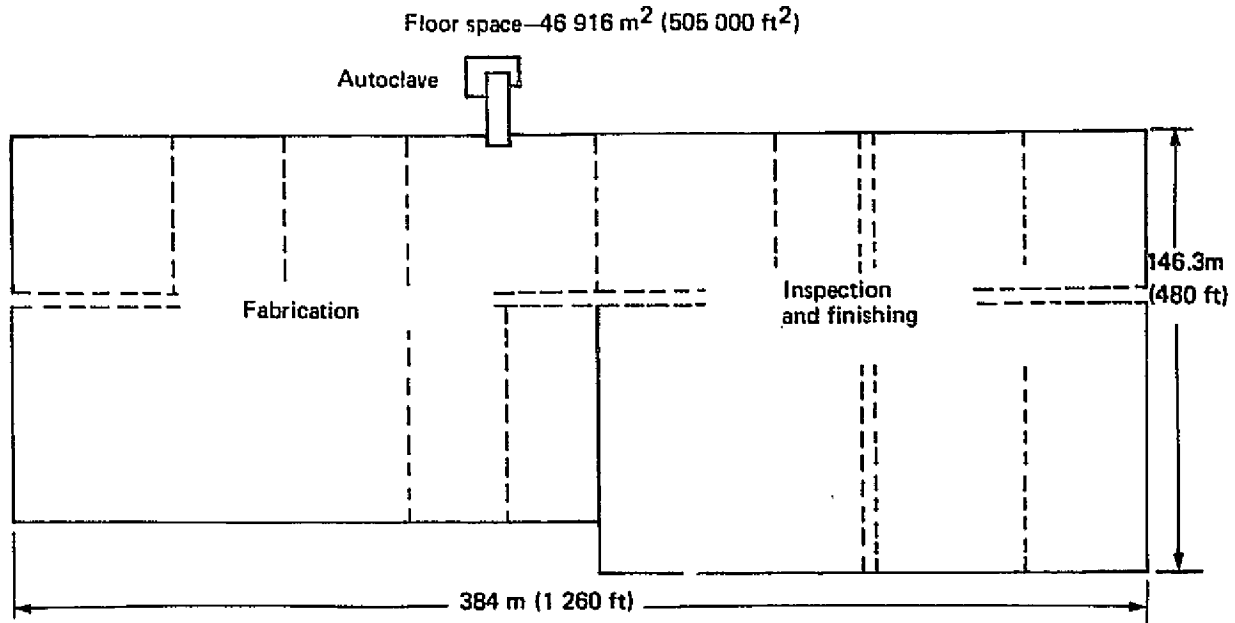

Figure 4-9 Production Fabrication Facility

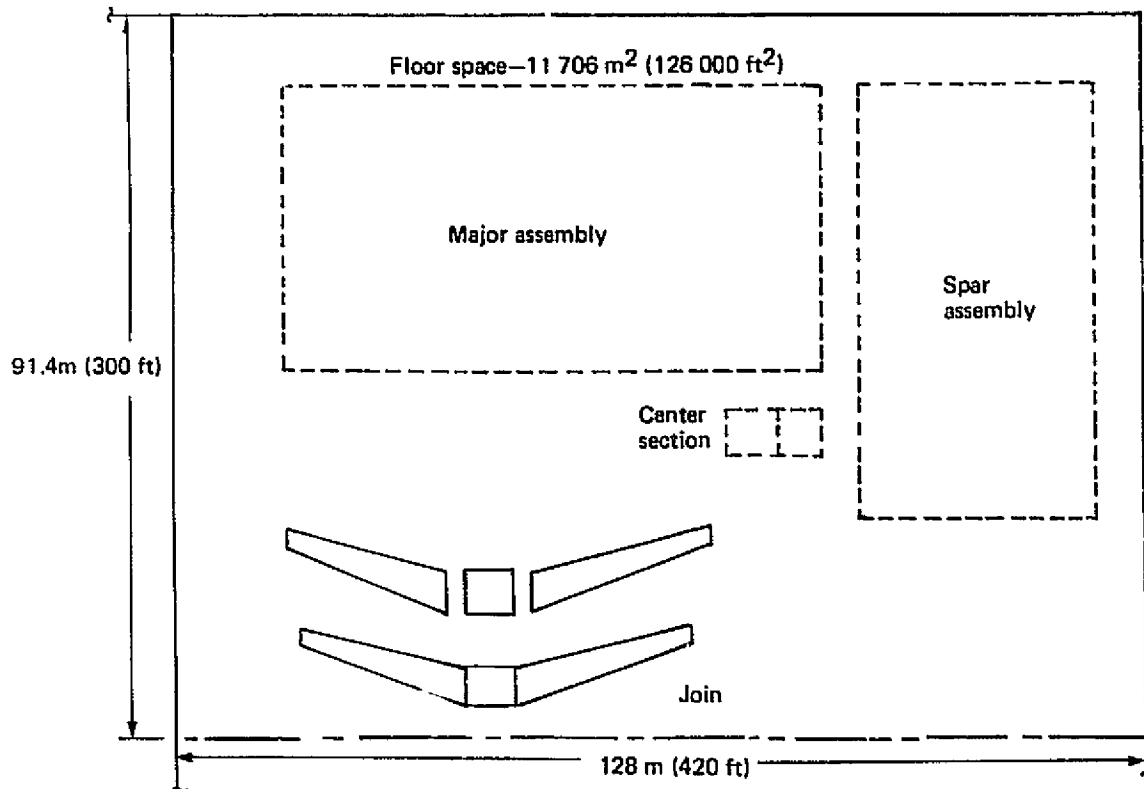

Figure 4-10 Production Assembly Facility

#### Quality Assurance

- Material acceptance improvements
- In-process adaptive controls
- Skin panel cure monitoring
- Automated nondestructive inspection methods

#### Fabrication Processes

- Filament winding long structural shapes
- Automated layup machine for large panel
- Tapering thick-sandwich pultrusion development
- Elastomeric die molding structural components
- Automated prepreg cutting center
- Improved prepreg materials
- Repair methods

#### Assembly Methods

- Hole preparation
- Fastening systems
- Sealant and sealant application
- Automated assembly - equipment

These requirements represent the major items that were addressed in the process development plan. Figure 4-11 provides the schedule for the process development efforts. They will be discussed later in this section.

The initial step in preparing the production development plan was the assessment of the current advanced composites production technology base. This step identified the technology needs for making a production commitment to advanced composites wing structure.

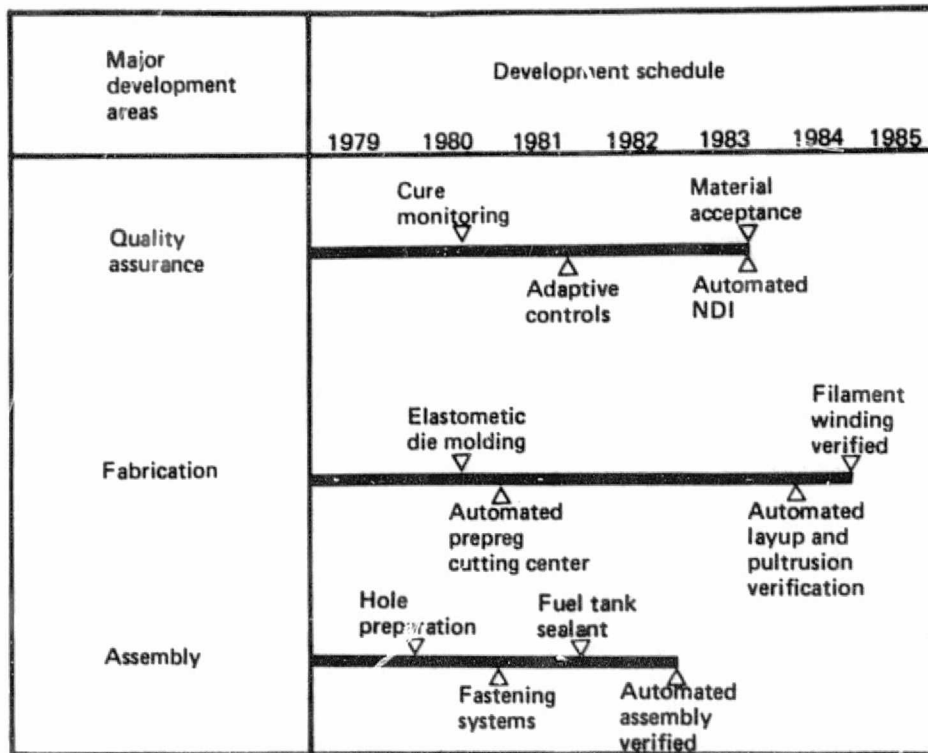

Figure 4-11 Process Development Schedule

Technology Assessment - The technology assessment involved an evaluation of the manufacturing and quality assurance state-of-the-art. Information for the assessment was obtained from industry contacts, Department of Defense contract reports, Boeing research programs, and NASA contracts. Emphasis was given to the information that will be obtained from the NASA Research and Technology and NASA Aircraft Energy Efficiency (ACEE) Programs.

These on-going efforts were assessed for the significance of their contributions. Three levels of contribution were used; limited, moderate, and significant.

Table 4-1 provides the results of the technology assessment. In summary, there is a limited technology base in quality assurance and a moderate technology base in the detail fabrication and assembly areas to support wing production process development.

Quality Assurance Development - Quality Assurance development efforts are required to establish: 1) improved receiving inspection techniques, 2) in-process adaptive control system for the automated fabrication processes, such as filament winding, 3) cure monitoring methods and 4) automated non-destructive inspection. The following further describes these development efforts.

To support wing production, improved receiving methods for acceptance material must be developed. Current receiving inspection methods are slow and costly. The initial developments will include a system of chemically characterizing the prepreg resin. Following this will be a fiber analysis system which will automatically determine fiber mechanical properties. Together these systems will allow fast and accurate inspection and improved quality control.

Table 4-1 Production Capability Assessment Sheet

Technology Item	NASA ACEE Programs							Other programs							Extent of existing technology base
	727 Elevator	737 Stabilizer	DC-10 rudder	DC-10 fin	L-1011 aileron	L-1011 fin	Air Force programs	Navy programs	NASA R&T	Boeing IR&D	Boeing new PPO-duct development	747 Components	777 Components	Industry	
<b>Detail fabrication</b>															
Tapered shape pultrusion									1	1				2	
Sandwich panel pultrusion									1	1		1		2	
LG shape pultrusion									1	1				2	
Contoured shape pultrusion									1	1				3	
Cocuring	1	1	2	2	2	2	2	2	1	1	1	1	2	1	
Filament winding							1	1	1	1		3		2	
Thermoplastic forming	2	2						2	1	1				2	
Compression molding	3	3							1	2	3	3		1	
Conv GR/EP machining				3		1			1	2	2		3	2	
Laser & water jet trimming	1	1							1	1	2	2		2	
TI prebond treatment									1	1				2	
<b>Assembly processes</b>															
New fastener concepts	1	2		1	1	1			1		1		1	2	
Advanced comp fasteners					2	2	2		1				2	2	
Titanium rivets	1				3		2		1				2	2	
Titanium nutplates	1								1				2	2	
Bund fasteners		1				3			1		2	2	3	2	
GR/EP hole prep improv	3	3	3	3	3	3	3		1	2	2	2	3	2	
GR/EP metal hole prep	2	2	3	3	3	3	3		1	2	2	2	3	2	
Hole quality allowables									1					3	
Dust collection	2	2				3			1		2	2	3	2	
Corrosion protect/sealing	2	2				3			1		2		2	2	
<b>Materials</b>															
Improved prepregs	2	2				1	3	1	1	2	2	2	2	1	
Pultrusion prepregs						2	3		2	3			2	2	
Adhesives	3	3				2	3	3	2	3	3	3	2	2	
Thermoplastic comp						1	1	2	2	3			2	3	
Chopped fiber molding						2	2	2	2	3			2	2	
Preplied broadgoods						1		3	2				3	2	
Lightning strike protect	3	3		3		1	2	3		3	3	3	2	2	
Exterior finishes	2	2								2	2			2	
<b>Tooling concepts</b>															
Mat					3	3	1							3	
Mechanized layup	1	1				1								2	
Tooling advancements								2	1		2			2	
Compression molding	3	3		3	3	2	3	3	2	2	1	2	2	2	
Elastomeric mold/cocure			1			1							3	3	
Captive elastomeric mold			1			2			2				2	2	
Integrally heated dies						1							1	2	
Inflatable mandrels															
<b>Quality assurance</b>															
Mat'l acceptance improv	2	2				2		2	1	2			2	2	
Cure monitoring			3						2					3	
In-line process control														3	
NDI methods	2	2	3	3	3	3	3	3	1	2	2	2	3	2	
LG/contoured panel NDT						3								3	
Maintenance and repair procedures	1	1	2	3	3	3	2	2	2	2	1	1	2	2	

Level of contribution: (1) Significant (2) Moderate (3) Limited

ORIGINAL PAGE IS  
OF POOR QUALITY

Boeing Commercial  
Airplane Company  
Contract NAS1-15003

Current techniques used to fabricate composite components require visual inspection of individual plies as they are laid. These techniques will not be practical for the automated fabrication processes.

Layup, filament winding, and pultrusion processes will require an adaptive control system that can identify defects as they occur.

The control system will then correct the error or stop the operations. Also, video records will automatically be made for later inspection. The shape pultrusion process will incorporate such a control system by the end of 1979. Development of adaptive controls for filament winding and automated layup will proceed along with these manufacturing processes.

The high cost of scrapping a wing component that is improperly cured makes the development of a system for monitoring and controlling the cure cycle mandatory. The initial task involves correlating cure-cycle variables to the actual physical properties of the laminate. A system will then be developed to automatically monitor the cure throughout the part, and control the cure cycle. This system is scheduled to be implemented into production by the end of 1980.

The wing box components will require nondestructive inspection. A developmental through-transmission ultrasonic inspection machine has been built for medium-sized components. However, this machine is slow and is difficult to maintain.

Additional means of inspecting advanced composites parts are being developed, including real time radiography, eddy current, and pulse echo. The most economical and effective of these techniques will be automated and verified.

Boeing Commercial  
Airplane Company  
Contract NAS1-15003

Fabrication Process Development - Detail fabrication is the most productive area for reducing wing structure manufacturing costs. Approximately 40% of the total cost (fabrication, assembly, material, tooling and quality assurance costs) is incurred during detail fabrication. Automated production processes, such as filament winding, machine layup, and pultrusion, must be developed to achieve the cost target of competitiveness with aluminum wing structure.

Filament winding is the most cost-effective method of fabrication of the spars.

Major development tasks include establishing a tool-concepts approach for the elastomeric covered winding mandrel, determining whether prepreg or a "wet" resin system will be required for winding, and establishing processing and handling methods for producing four spars on a mandrel. Deflection of the winding over an 24.38-m (80-ft) length will be a major concern. By the end of 1980, filament winding capability will be available to fabricate a 7.62-m (25-ft) long spar. This capability will be followed by winding of a full-scale spar configuration to verify the process for production.

As shown in Figure 4-7, an automated layup machine will be used to fabricate the outer skin plies of the cover panels, position the stiffener, and lay the closure layers that tie the stiffeners to the outer skin plies. A feasibility trade study and conceptual design of this machine will be accomplished initially. Efforts will concentrate on designing a dispensing head that can lay tape and woven fabrics up to 122 cm (48 in) wide. This design will be followed by the design and fabrication of a prototype machine capable of producing 4.57- by 7.62-m (15- by 25-ft) structure. The prototype machine will be available to fabricate the center section skin panels for the Option C fatigue and flight test wing hardware.

After manufacture of the Option C flight test panels (see Figure 4-22), a production machine will be designed and fabricated. Two full-size wing cover panels will be produced, using this machine to verify the processing and tooling concepts prior to 1985 production commitment.

The Boeing pultrusion process involves the pulling of graphite/epoxy prepreg through a shaped ceramic die, while affecting a continuous cure of the advanced composites material simultaneously with its compaction during the passage through the die. Microwave energy is used for the curing of the material. A feed system is used to handle and feed advanced composites prepreg tapes into the microwave curing chamber containing the ceramic die.

The stiffener has a tapering solid cap on the top and bottom and a corresponding expanding core section between the caps to maintain a consistent 7.62-cm (3-in) high exterior dimension. A tapered thickness and thick sandwich panel pultrusion capability will be developed to fabricate the stiffeners.

This will be accomplished by the end of 1982 to facilitate implementation on the Option C flight test hardware center section. The pultrusion stiffener process will also be verified to support the 1985 production commitment by fabricating full-size wing hardware.

The wing ribs will be elastomeric die molded. The initial development will involve establishing processing parameters and tooling concepts. Following feasibility studies and refinement efforts, the molding process will be used to produce the outboard ribs for the static, fatigue, and flight test hardware for Option C.

Other development efforts that will be accomplished to support the production plan and the 1985 production commitment include: 1) automated prepreg

cutting (kitting) center, 2) improved prepreg materials (lower flow, less brittle, no-bleed resin system) and, 3) repair methods. The last two efforts will be worked in cooperation with the engineering technology development activities.

Assembly Process Development - To further reduce the manufacturing cost, improved methods and automated equipment will be developed for assembling wing structure. Areas that will be emphasized include hole preparation and fastening system, sealants and application methods, and automated assembly equipment.

Techniques and equipment have been established for drilling and fastening all graphite/epoxy and graphite/metal combinations. However, improvements will be developed to support wing structure assembly. These involve defining hole quality allowables such as fastener fit, fiber breakout, and fiber/resin erosion; and developing methods for producing holes and fastening titanium/graphite stack-ups at acceptable production rates and quality. Other improvements include establishing a dust collection system for drilling, reaming, and countersinking graphite/epoxy advanced composites, and developing fasteners and assembly methods for wing structure. All of these improvements will be integrated with and validated through the wing test hardware of Option C.

Material with improved strength and porosity, and methods for rapid installation will be developed for wing tank sealing. These will be available on the wing test hardware.

Automated assembly equipment, similar to the numerical control metal spar machine shown in Figure 4-8, will be developed to eliminate the current labor-intensive drilling and fastening methods. This equipment will be used

Boeing Commercial  
Airplane Company  
Contract NAS1-15003

for assembling the center section spars on the Option C flight test hardware. The equipment will be verified by assembling the full-scale, filament-wound verification spar.

Process Integration and Validation - Figure 4-12 lists the process validation that will be accomplished for the quality assurance, fabrication, and assembly capability developments. The filament winding, automated layup and pultrusion processes will be partially validated by fabricating the wing center section for the Option C ground and flight test hardware. Validation of the automated kitting equipment and elastomeric molding will also be done during manufacturing of the Option C hardware. For the production commitment, additional verification will be required for spar filament winding, automated cover panel layup, stiffener pultrusion, automated spar assembly, and automated cover panel nondestructive inspection. This will be accomplished by fabricating full-size hardware.

#### 4.3 INTEGRATION AND VALIDATION HARDWARE DEVELOPMENT OPTIONS

This section describes the four hardware options that were developed to provide the integration and validation needed for a production commitment. Options discussed were selected to provide a range of risks, costs, and overall development approaches. The principal milestone in each case is "production commitment readiness." At that time, there would exist a state of readiness from technical, cost, risk, and benefits points of view, but staffing and production facilities would remain to be committed and acquired.

Principal goals of the hardware development options are to integrate and validate the design, production concepts, and production cost projections; define certification requirements; and validate anticipated cost and weight benefits. An underlying requirement is that the hardware option selected

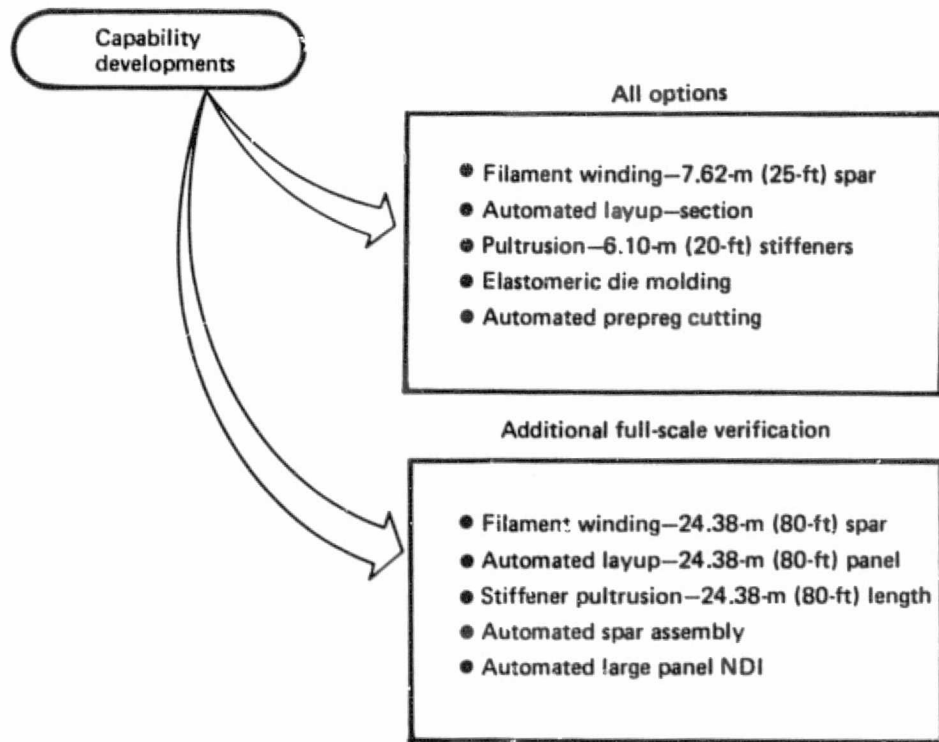

Figure 4-12 Process Integration and Validation

should develop confidence in advanced composites primary structure sufficient to lead both manufacturers and airlines to make the desired commitment.

#### 4.3.1 Description

Development of a full-scale, realistic primary structural component is necessary to satisfy integration and validation requirements. Design, certification, and production capability risks are too high for a production commitment without operational hardware validation. Options that were studied in detail are based on existing aluminum wing boxes, because of anticipated significant advantages in having an aluminum baseline for direct comparison of costs and weights, and in having an actual design configuration to force design realism. Four options were studied.

Option A is a ground test of a Boeing Model 737 wing box shown in Figure 4-13, from the side-of-body splice to the outboard tip. Principal tests that would be addressed would include static and fatigue tests, damage tolerance tests, and system tests including lightning strike.

Option B provides a minimum amount of flight service experience in addition to the ground tests of Option A. This option thus consists of a Model 737 ground test wing identical to Option A, plus a Model 707 outboard wing section (Figure 4-14). The Model 707 wing has a production splice outboard of the outboard engine that provides an easily removable section approximately 6.10 m (20 ft) long, which contains an integral fuel tank and vent system and which is in a critical lightning-strike zone.

Options C and D are similar except for the airplanes, which are a Model 737 (Figure 4-15) and a Model 727 (Figure 4-16), respectively. These options utilize two wing-ground test sections, comprised of a center section as well

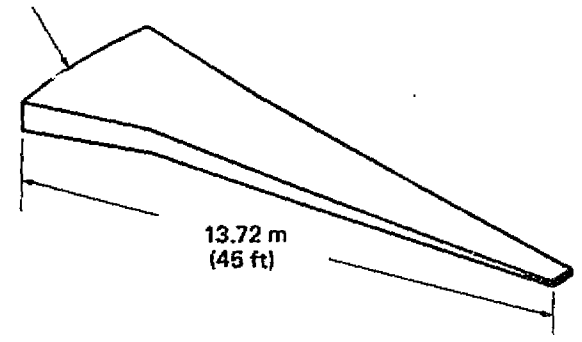

Figure 4-13 Option A—Ground Test 737 Left-Hand Wing Box

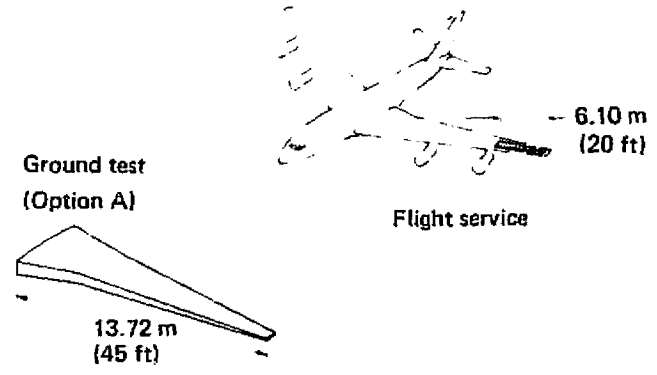
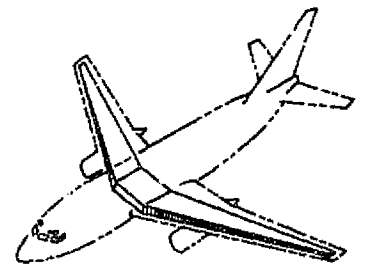

Figure 4-14 Option B—707 Outboard Wing Flight Service

06

Left-hand wing ground test

Static and systems tests



Fatigue tests

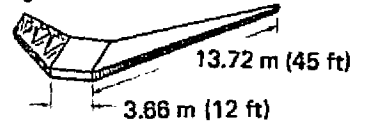

Flight service tip-to-tip—28.35m (93 ft)

Figure 4-15 Option C—737 Wing Box

Left-hand wing ground test

Static and systems tests

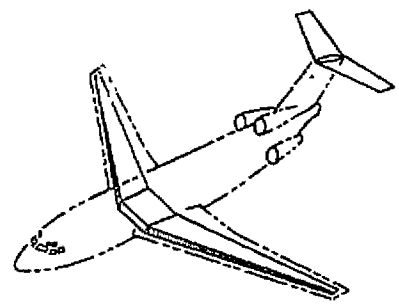

Fatigue tests

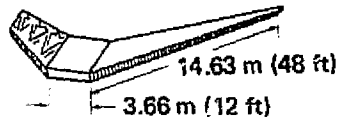

Flight service tip-to-tip—32.92 m (108 ft)

Figure 4-16 Option D—727 Wing Box

ORIGINAL PAGE IS  
OF POOR QUALITY

Boeing Commercial  
Airplane Company  
Contract NAS1-15003

as the side-of-body-to-tip section. Thus, center section development and fuselage interface development are included. One wing section would be used for static and systems tests, and the other would be used for fatigue tests. Included in each of these programs is flight service of a full tip-to-tip wing utilizing a third test article.

#### 4.3.2 Program Option Evaluation

Evaluation of the above described integration and validation options was based on risk, cost, and benefits of each option with respect to the production readiness commitment goals. It is important to note that evaluations of risk were made with respect to the ability of an option to support the production commitment, not with respect to the ability to successfully complete the option itself.

In the following discussion, the options are evaluated on a relative basis with respect to key requirements. Evaluations are made by judgment, and are summarized by their anticipated level of risk to a successful production program with a given option as the precursor. Final selection is made by comparing program cost with the risk as described.

Evaluations were subdivided into technical, production, and financial areas. Technical considerations include principal technology development, design readiness, and demonstration of the certification process. Production considerations are production plan validation, cost data substantiation, and resource availability verification. Airline acceptance considerations included cost and weight validation, technical foundation validation, and flight experience.

Table 4-2 summarizes the technical evaluation for the four options. All options provide a high level of testing and design development, with a higher level provided by Options C and D due to inclusion of a wing center section. Option A does not demonstrate the certification process, as the ground test wing box is not certified. Option B provides only certification of an outboard section.



Table 4-3 summarizes the manufacturing evaluation. Option A lacks the opportunity to use production processes in the test article and limits the probability of successfully reaching production plan verification and cost data validation goals. Option B adds to the production experience base but decreases total manufacturing risk only slightly. Options C and D provide a much broader experience base than the other options by including the use of production processes in the manufacture of test articles. However, there can be a substantial scale-up in size and effort for the larger 1985-90 production wing, a remaining element of risk considered acceptable.

Airline acceptance evaluation is summarized in Table 4-4. The principal shortcoming of Option A is that no flight service is provided, an element considered to be a necessary part of airline acceptance and the marketing efforts. Option B provides a significant flight service program in a technically critical area, and gives a minimal maintenance background. Options C and D provide good flight service background of the complete wing box and integrated systems, and are anticipated to be sufficient to substantiate maintenance cost data and repair concepts.

#### 4.3.3 Summary and Recommendation

Table 4-5 summarizes the previous evaluations together, with relative cost data and an estimation of the change of a successful option program supporting the desired production commitment. Options A and B provide major building

Table 4-2 Technical Evaluation

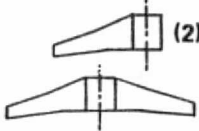
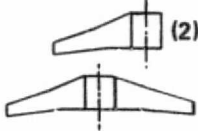
Does option:	A 	B 	C 	D 
Provide development of identified areas sufficient to ensure freedom from major faults?	Probably—does not include center section	Same as (A)	Yes	Yes
Provide design development background so that production design can be readily initiated?	Probably—does not include center section, but not critical	Same as (A), but additional experience gained by outboard 707 wing section	Yes	Yes
Provide sufficient schedule flexibility to allow design/technology integration/validation?	Probably—depends on task, sequence, timing (1)	Yes	Yes	Yes
Demonstrate FAA certification processes (for production airplane)?	No—supplies data, but certification process probably incomplete	Probably a minimal program with some uncertainty	Yes	Yes
Risk Evaluation	High—unacceptable	Marginal—probably unacceptable	Low—acceptable	Low—acceptable

(1) Could be improved by schedule extension

Boeing Commercial  
Airplane Company  
Contract NAS1-15003

ORIGINAL PAGE IS  
OF POOR QUALITY

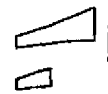
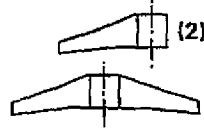
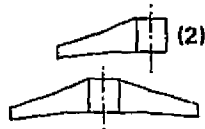

Table 4-3 Manufacturing Evaluation

Does option:	A	B	C	D
				
Validate production manufacturing plan?	No—insufficient use of production methods (1)	Same as (A)	Substantial—some use of production methods (1)	Same as (C)
Establish required cost data?	No—insufficient number of units, use of production methods	Same as (A)	Partially—more use of production methods desirable (1)	Same as (C)
Ensure resource availability?	Yes	Yes	Yes	Yes
Risk Evaluation	High—unacceptable	High—unacceptable	Low—considered acceptable	Low—same as (C)

(1) Could be increased by schedule extension

Table 4-4 Airline Acceptance Evaluation (1985)

Boeing Commercial  
Airplane Company  
Contract NAS1-15003

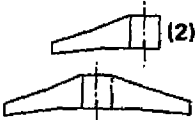
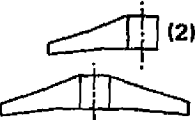
Does option:	A 	B 	C 	D 
Provide substantiation of costs/weights to validate benefit?	No/Yes	No/Yes	Partially/Yes (see manufacturing evaluation)	Same as (C)
Ensure technical foundation is free of major faults?	Partially—does not provide flight service experience	Partially—flight service not for complete wing, but is significant	Yes	Yes
Provide flight experience for in-service system validation?	No—no flight service program	Partially—outboard wing area only	Yes	Yes
Risk evaluation	High—unacceptable	Marginal	Low—acceptable	Low—acceptable

*Table 4-5 Option Evaluation Summary*

Option	Description	Relative cost	Technical risk	Production risk	Degree of airline acceptance	Chance of a successful program leading to a production commitment
A	737 Outboard wing ground test	1.0	High	High	Low	Poor (building block)
B	Option A plus 707 partial wing flight test	1.4	Marginal	High	Marginal	Marginal
C	737 Ground test + tip-to-tip flight test	2.1	Low	Acceptable	High	Good
D	727 Ground test + tip-to-tip flight test	2.4	Low	Acceptable	High	Good

Boeing Commercial  
Airplane Company  
Contract NAS1-15003

blocks for more gradual development programs, other than a 1985 commitment. Only efforts of the scope of Options C and D can successfully meet the goal of production readiness commitment at acceptable risk in 1985. Option C is selected as the recommended integration and validation option, with Option D providing an alternative program depending on flight service airplane availability.

#### 4.3.4 Option C

Option C utilizes two wing-ground test articles comprised of center wing and left-hand side-of-body-to-wing-tip sections, plus a third tip-to-tip wing section for flight service evaluation.

One ground test article is used for static and system tests. The other would be used for fatigue and damage tolerance tests.

The schedule for Option C, showing the major milestones from design development through flight service evaluation, is shown in Figure 4-17.

The manufacturing development phase consists of process integration and validation. Table 4-6 identifies the process validation that will be accomplished for quality assurance, fabrication, and assembly capabilities.

Significant capabilities to be validated:

- A prototype fabric-dispensing machine will be available to fabricate the wing center section skin panels for the fatigue and flight test articles
- A filament-winding machine will be available to fabricate front and rear spars for the static, fatigue, and flight test articles

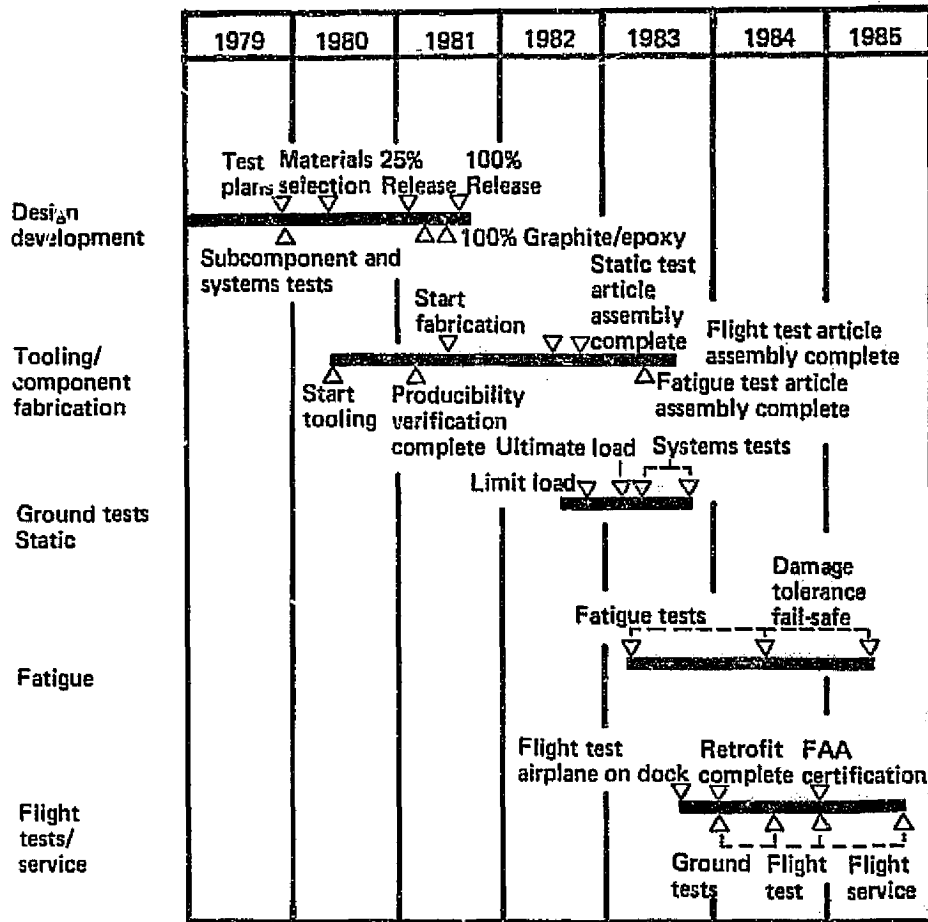

Figure 4-17 Option C Schedule

*CL*

Table 4-6 Production Capability Integration and Validation Process—Option C

Option C	Fabrication processes							Assembly methods				Quality assurance	
	Filament winding	Automated layup	Pultrusion	Elastomeric die molding	Automated prepreg cutting	Hole preparation	Fastening systems	Sealant and application	Automated assembly	Receiving inspection	In-process controls	Cure monitoring	Automated NDI
Static				X		X	X			X		X	
Center section	X					X	X			X			
Fatigue				X	X	X	X			X	X	X	
Center section	X	X			X	X	X			X	X		
Flight				X	X	X	X	X		X	X	X	
Center section	X	X	X		X	X	X	X		X	X		

- A pultruding machine will be available for fabricating thick, constant-height stiffeners for the center section of the flight test article
- Elastomeric die molding will be used to produce outboard ribs for the static, fatigue, and flight test articles
- A prototype automated fabric kitting machine will be available for cutting the outboard ribs on the flight test article

The design development phase consists of three segments, which are:

- Preliminary design and integration of the structural concepts described in Paragraph 3.2 into the existing 737 wing box to develop a baseline configuration
- Design of subcomponents to support the structural development tests, systems testing, and manufacturing technology tasks
- Final design of the ground test articles and flight service evaluation vehicle

Preliminary design development includes the integration of the existing metal control surfaces, and their interfaces with the structural box, together with the systems requirements to achieve an optimum baseline configuration.

The subcomponent design task is the refinement of the basic structural concepts and their application to the structural development testing (Figure 4-18) to provide verification of these concepts and further the detail design, including the integration of systems into the design based on the results of the systems development tests outlined in Figure 4-19.

The final portion of the design development phase is the design of the ground test articles and the flight service evaluation vehicle. This is the

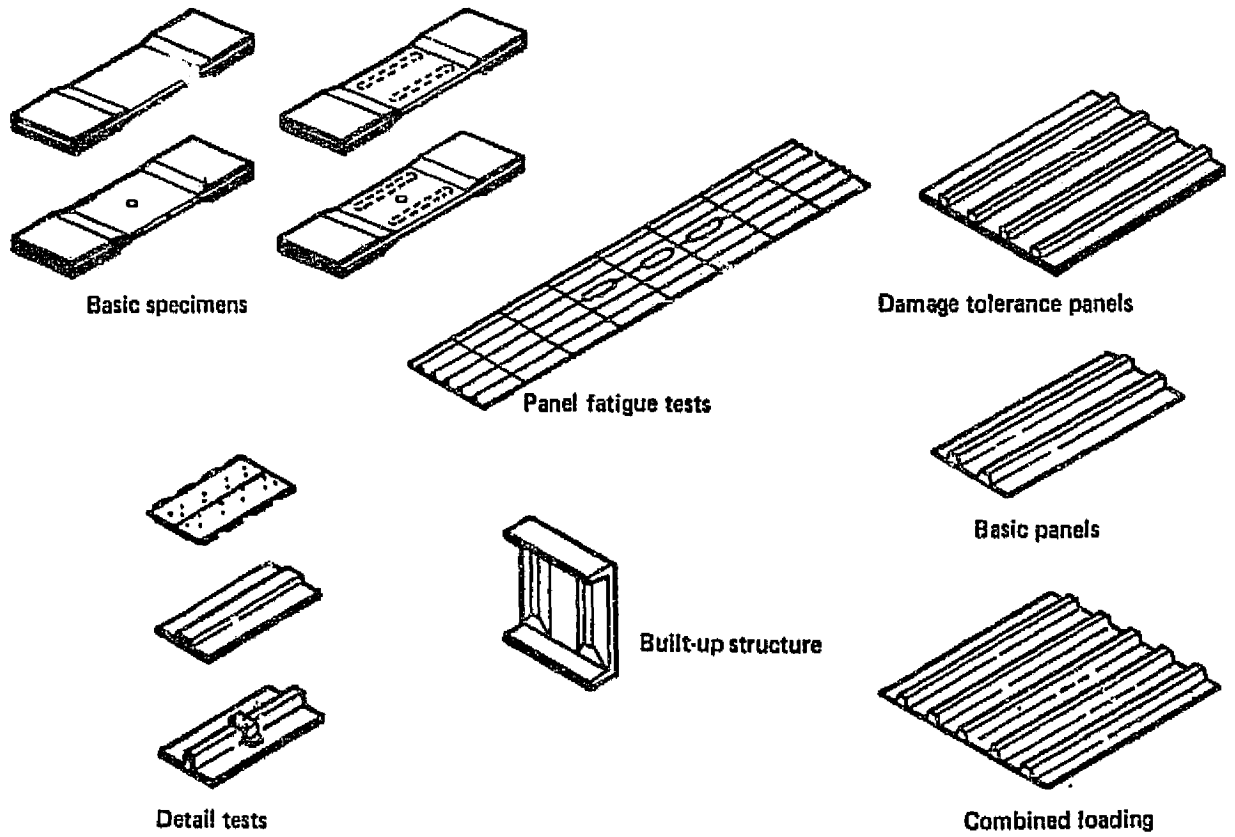

Figure 4-18 Structural Development Tests

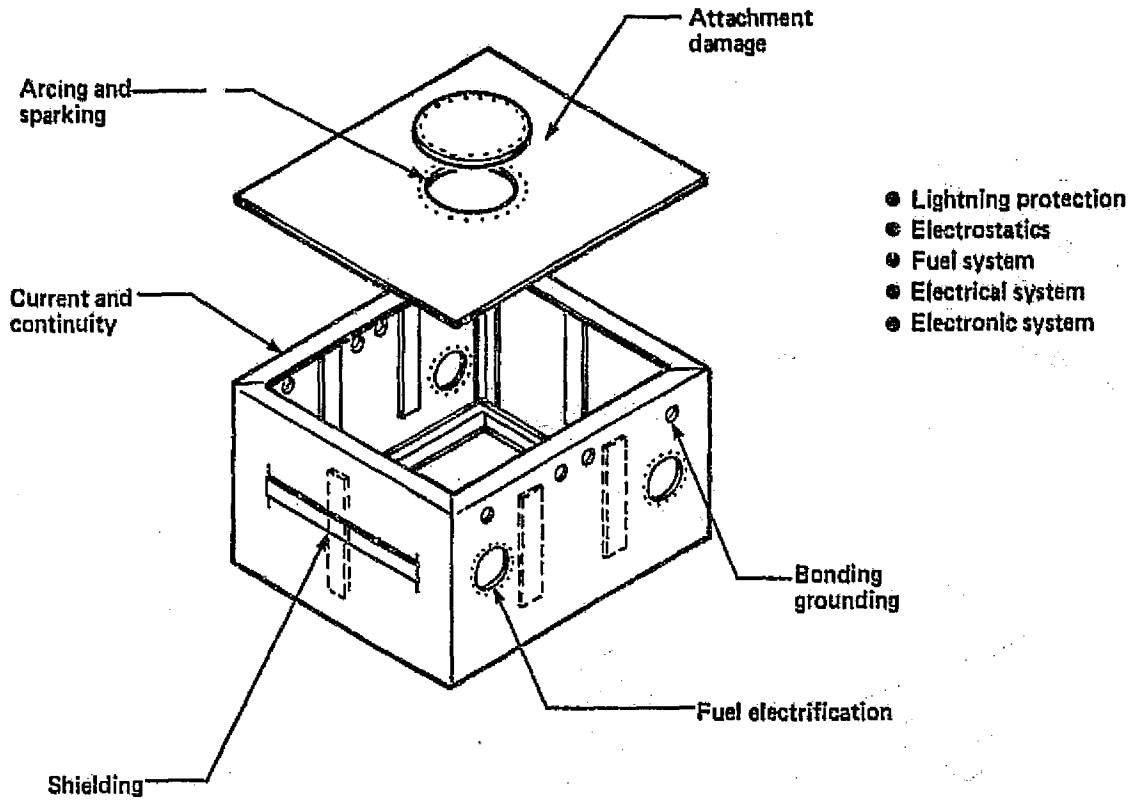

Figure 4-19 System Development Tests

integration of the efforts of the structural development testing, systems testing, and manufacturing technology tasks, which have provided ongoing building-block support to the design activity to achieve the final design.

The design development phase, shown in Figure 4-17, defines the wing configuration, and involves the integration of engineering and manufacturing technology. Initial testing in this phase must support material selection, structural component definition, and systems and manufacturing feasibility. A product of this phase will be the establishment of design criteria that will determine minimum gage, stiffness requirements, and inspectable damage.

This design effort will also produce an overall test plan that addresses scheduling of tests to meet program milestones, establishes the data requirements that will be needed for certification, and further establishes the support needed from the technology development program. In support of the program design phase, material mechanical property and panel data of suitable quality must be generated. The thickness of the advanced composites laminates for wing design will, in general, be greater than the maximum gages in the mechanical properties tests associated with the current ACEE programs. Although, current programs will establish the parametric information pertaining to process variations, tolerances, and environmental exposure effects, basic mechanical properties testing of the thicker laminates will still be required. Figure 4-18 shows examples of the types of panel and subcomponent tests that must be conducted to support design activity by supplying strength, durability, and damage tolerance data for all structural components being developed.

These tests will establish the critical failure modes for combinations of temperature and moisture content. A series of systems tests will also be performed to prove that the selected concept meets electromagnetic and fuel

system requirements. Figure 4-19 shows a typical developmental test box that will be used for these tests.

The major structural and system tests will supply the data to develop and verify the analysis methods that will be used for certification. In commercial aircraft design criteria, the manufacturer has the option of designing to either damage-tolerant or safe-life criteria. All present commercial aircraft of United States origin are designed to the damage-tolerance concept. The Boeing Company will continue to use this design philosophy, which is considered essential in achieving high levels of safety. Therefore, damage tolerance and static strength proof-of-structure testing is necessary to validate analysis methods. The major structural test articles will involve a fully representative advanced composites wing box primary structure, as shown in Figure 4-20. Fixed leading-edge and trailing-edge structure will also be represented, and the test setups, loading systems, instrumentation, and critical conditions to be investigated have been defined in detail. The schedule for major structural and system tests, and the principal information derived from them, is shown in Figure 4-21.

Static testing will be performed at ambient temperature. The effects of temperature and moisture, and the possible degradation of strength due to previously applied loads, will be accounted for in the test results.

The damage tolerance testing, which is shown to follow the fatigue test (Figure 4-17), will also be at ambient conditions. Damage growth tests will be conducted by introducing damage at several locations, and by testing with repeated load cycles to obtain damage growth rate curves. Compliance with residual strength requirements will then be demonstrated by loading to damage tolerance load levels as defined by FAA requirements. The damaged areas will be increased, or additional areas will be damaged, if necessary.

Test article

- Fully representative left-hand wing box
- Center section
- Fixed leading edge and trailing edge
- Landing gear beam
- Engine strut
- Body structure adjacent to the wing

Dummy or simulated structure

- Right-hand wing

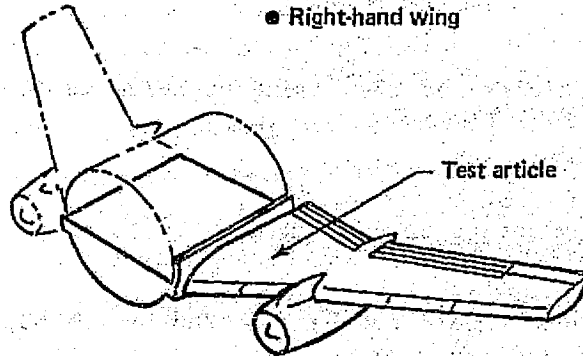

Figure 4-20 Major Structural Tests

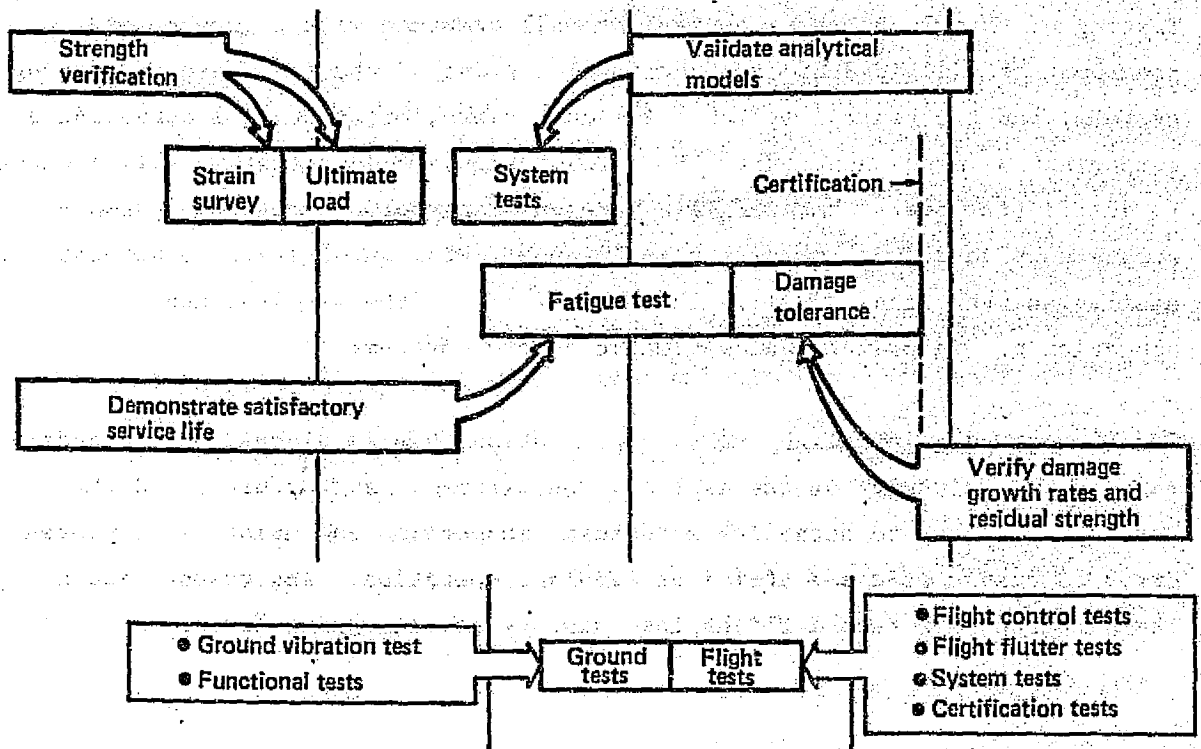

Figure 4-21 Major Structural and System Tests

to satisfy the defined damage tolerance criteria. The purpose of the major fatigue test is to expose details that are fatigue sensitive. It is especially useful in exposing load path problems that do not exist in subcomponent tests. It will also assist in the in-service inspection of the flight evaluation airplane.

The reason for two test articles and the timing of tests was determined by two considerations:

- The strain survey should be performed early to support mathematical model validation
- Repeated load tests should not be preceded by the application of high loads, because they probably influence fatigue performance and may affect the results of damage growth and residual strength testing

Testing of the flight service airplane will commence with a ground test program that will include the functional testing of the fuel feed and gaging systems, and the control system. A ground vibrations test will establish a comparison of mode shapes with the metal design. Flight testing will include flight flutter tests, covering a sufficient range of parameters to demonstrate compliance with certification requirements, and testing to demonstrate stall, maneuver, and stability characteristics of the airplane and the operation of the primary and automatic control system.

The 12-month airline flight service evaluation that is planned will necessitate the coordination of the airline, the airframe manufacturer, and the certifying agency to establish structural inspection and maintenance procedures to ensure safe and efficient airplane operation. Instrumentation on the airplane will record flight load history and lightning strike data. It

Boeing Commercial  
Airplane Company  
Contract NAS1-15003

is estimated that the airplane will be struck by lightning at least once during the test period. Other areas that will be monitored at regular intervals will be the fuel systems, including tank sealant, and protective systems and finishes.

Operation of the evaluation airplane by a commercial airline is considered an important step in the plan to provide the confidence in advanced composites wing structure that is necessary prior to production commitment readiness. This program brings about involvement of the airline and manufacturer in identifying and solving actual problems associated with actual airplane operation. The service evaluation obviously involves more than the accumulation and verification of technical data. Confidence involves many intangible factors, such as realism of the environment in which tests are performed.

#### 4.4 RECOMMENDED PROGRAM SCHEDULE

The recommended program schedule is 82 months long, including a 12-month flight service evaluation. Based on an assumed go-ahead of January 1, 1979, a production readiness commitment would be made in 1985. The program would be concluded in October, 1985, with the completion of the flight service evaluation, (see Figure 4-17).

Accomplishment of the three major program elements will follow the integrated schedule plan shown in Figure 4-22. Technology and production capability development efforts are integrated for maximum support from Option C wing box design, fabrication, and test. Continuing development activities will build from the earlier results, and establish the desired expanded technological basis for a production readiness commitment in 1985. See Table 4-5 for option evaluation and relative cost.

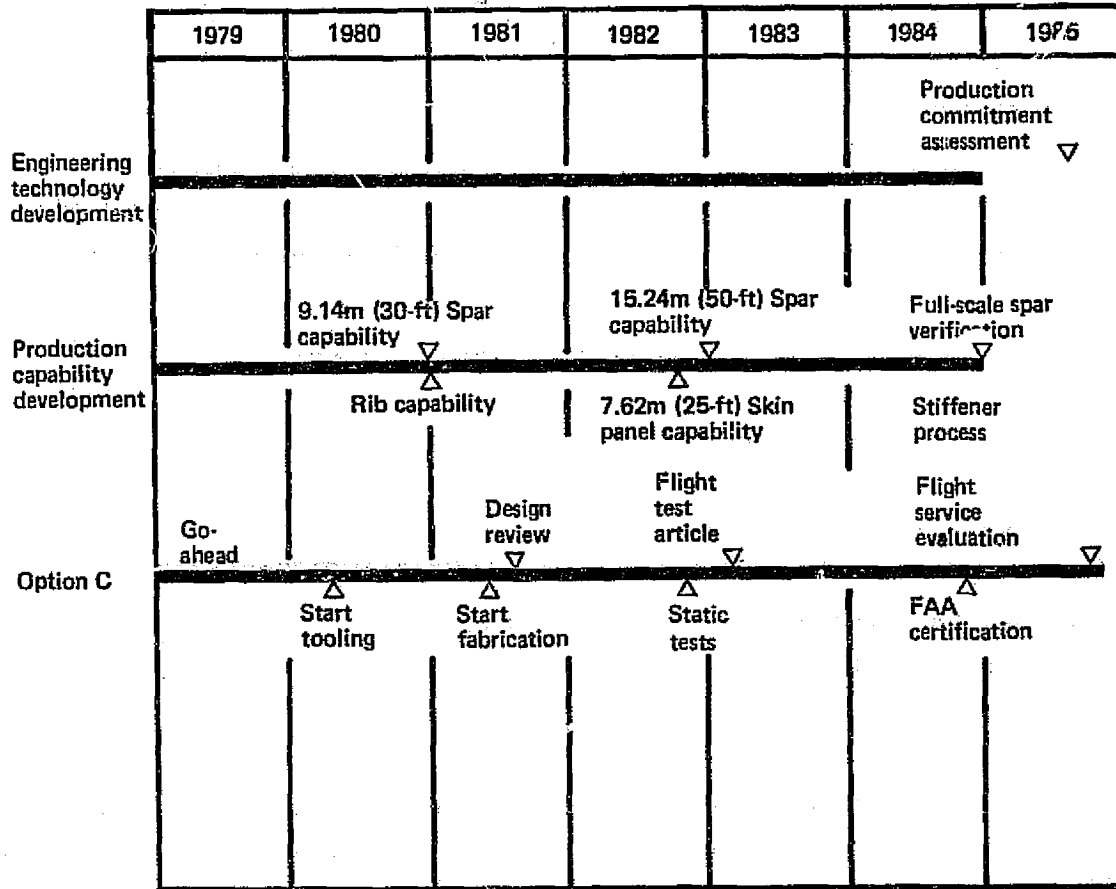

Figure 4-22 Recommended Program Schedule—Option C

Boeing Commercial  
Airplane Company  
Contract NAS1-15003

## SECTION 5.0

### AIRLINE COORDINATION

An important area of any Boeing commitment that affects a commercial transport involves the customer. Early involvement with the airlines, and identification of their concerns, can minimize potential end-item problems.

In summary, the airlines have expressed concern with lightning strike effects, and repair and maintenance, and have suggested that flight demonstration of a wet wing would be a good confidence builder. The success of current programs using graphite/epoxy in routine airline service will determine to a large extent the airline operator's ready acceptance of this material. Coordination with the airlines is a continuing endeavor that would actually go on long past a production commitment of an advanced composites wing structure.

SECTION 6.0

FAA CERTIFICATION

The successful application of advanced composites to primary wing structure is dependent upon the maintenance or improvement of the current levels of safety provided by metallic structure. To achieve this level of safety, designs using advanced composites will require considerable development and verification before they are accepted for use in commercial aircraft primary structure. Specifics of the design to meet safety standards are guided by FAA certification regulations, and the current consensus in industry is that the requirements now written should be retained for advanced composites. Preliminary guidelines that propose acceptable means of achieving compliance for advanced composites structure with Federal Aviation Regulations are set forth in a draft Advisory Circular. This draft was the result of FAA/industry meetings. The criteria, although still in the development stage, are scheduled for initial completion in the near future. The evaluation criteria will undergo an updating process that will extend over a considerable time, with periodic meetings between FAA and key aviation specialists.

As part of the NASA Wing Study program, a meeting was arranged with the FAA for the purpose of discussing the activity and objectives of The Boeing Company's participation in the wing study, and to exchange information and views on advanced composites technology development. The test plans for technology development and each integration and validation option, which had been generated in some detail for costing purposes, were sent to the FAA prior to the meeting. A request was made that the FAA review the plans and determine if the approach and scope of the test plans were consistent with the FAA's present view of the level of development and test validation that may be required for composite wing certification.

**PRECEDING PAGE BLANK NOT FILMED**

Boeing Commercial  
Airplane Company  
Contract NAS1-15003

Subjects discussed at the meeting included The Boeing Company's certification philosophy, which has been to demonstrate accountability primarily by test-validated analysis procedures. This approach has had a successful history with metal structures. There are many reasons for its continued use, such as the impracticality of testing for all conditions. Other benefits derived from analysis methods include optimization procedures, and accounting for growth capability.

An outline of the extensive technology development efforts to be conducted in conjunction with the proposed design, fabrication, and flight evaluation program was also given. The technology development program is designed to provide the analysis tools required in the certification process, and to satisfy all environmental questions, including the effects of fuel on the material system.

The FAA concluded that it appeared that no major deficiencies exist in the structural substantiation test plans submitted to them. However, since the data were quite general in some testing and detail design areas, the FAA was unable to comment on the adequacy of the number or type of structural tests proposed, or which should be accomplished. It was agreed that future involvement with the FAA must include frequent and regular FAA-airframe manufacturer's meetings as the program develops.

## SECTION 7.0

### CONCLUSIONS

The wing program recommended by The Boeing Company maintains development momentum and expands on an established base of technology and skill. It is a logical and timely follow-on to the current NASA, Air Force, and industry graphite/epoxy development and production programs. A 7-year lead time plus forecast fuel price increases add support to the timeliness and logic of continuing development. A 20%-30% structural weight reduction in wing box structure compared with current aluminum wing boxes is attainable, and would contribute significantly to the NASA/ACEE program goal of achieving a minimum of 40% fuel saving over current designs. The cost to develop advanced composites for extensive commercial transport application is acceptable when balanced against the 12%-15% fuel savings attainable. Further, the benefits of extensive use of graphite/epoxy could be accomplished without requiring highly unusual skills to perform design and manufacturing activities.

Technology and production capability development, and hardware testing are necessary to establish acceptable risk levels before committing advanced composites wing structure to production. There is a need for extensive testing of advanced composites material to develop data on damage tolerance, durability/repeated loads, electromagnetic effects, environmental effects, and material improvements. Downstream developments in technology, such as advanced material resin systems, can be practically introduced when proven superior. Wing boxes of advanced composites materials must be fabricated and tested full-scale to provide production methods validation and adequate static and fatigue data for certification. To make graphite/epoxy cost competitive with aluminum, tools and processes need to be developed that

Boeing Commercial  
Airplane Company  
Contract NAS1-15003

will mechanize production fabrication of large components, and improve production assembly methods, materials repair techniques, and quality assurance.

Flight service experience under routine conditions with a commercial transport retrofitted with a wing box of advanced composites material is necessary to demonstrate positively to airlines the advantages of the material in the operator's environment.

Developing the needed technology and production capability, and obtaining FAA certification of advanced composites material primary wing structure can be accomplished over a period of 6 years assuming an aggressive, well-planned program with adequate funding.