

ANIMAL EXPOSURE DURING BURN TESTS

James G. Gaume
Douglas Aircraft Company
McDonnell-Douglas Corporation
Long Beach, California 90846

4 Title and Subtitle ANIMAL EXPOSURE DURING BURN TESTS FINAL REPORT
7 Author(s) James G. Gaume, M.D.
9 Performing Organization Name and Address Douglas Aircraft Company McDonnell Douglas Corporation 3855 Lakewood Blvd. Long Beach, California 90846

Abstract

An animal exposure test system (AETS) has been designed and fabricated for the purpose of collecting physiological and environmental (temperature) data from animal subjects exposed to combustion gases in large scale fire tests. The AETS consists of an open wire mesh, two-compartment cage, one containing an exercise wheel for small rodents, and the other containing one rat instrumented externally for electrocardiogram (ECG) and respiration. Cage temperature is measured by a thermistor located in the upper portion of the rat compartment. Temperature range recorded is 0°C to 100°C. The ECG and respiration sensors are located in a belt placed around the torso of the subject, electrode wires forming an umbilical to a connector in the top of the compartment. A cable extends from the connector to the power supply and signal conditioning electronics. These are connected to a dual-beam oscilloscope for real-time monitoring and a magnetic tape recorder having three or more channels. After the burn test, the data on the tape is reproduced in the laboratory on an 8-channel Beckman Type SII Dynagraph for analysis. Endpoints observed are bradycardia, cardiac arrhythmias, changes in respiratory pattern, respiratory arrest and cardiac arrest. The ECG record also appears to be a good method of monitoring of animal activity as indicated by an increase in EMG (electromyograph) noise superimposed on the record during increased activity of the torso musculature. Examples of the recordings are presented and discussed as to their significance regarding toxicity of fire gases and specific events occurring during the test.

The AETS has been shown to be a useful test tool in screening materials for the relative toxicity of their outgassing products during pyrolysis and combustion. Recommendations for future effort include (1) improvement of the system effectiveness, (2) utilization of the system to enlarge the data bank of physiological responses to fire gases, (3) investigation in the laboratory of the responses to selected fire gases and extinguishing agents, singly and in combination.

OBJECTIVES

The objectives of this program have been:

1. To develop an animal exposure test system (AETS) for utilizing small animals as subjects (S_s) in large-scale burn tests. The AETS should be capable of being standardized so that any investigator, following the specifications set forth, can build and utilize the system and achieve results which can be accurately compared with those of another investigator using the same system.
2. To utilize the AETS in large-scale burn tests to collect physiological (cardiac and respiratory), environmental (temperature), and physical activity data to enable the relative toxic threat assessment of burning materials, in single or multiple specimens. The system should also be applicable to various laboratory-scale experiments without or with minor modifications.

APPROACH

Douglas studied the NASA plans, protocols, schematics for the full-scale burn tests of an aircraft lavatory to be conducted in 1975 at the test facilities of the Boeing Company, Seattle, Washington (7) and of a simulated lavatory at the University of California at Berkeley (Richmond) (8). The design requirements and criteria for a standardizable animal exposure test system (AETS) were developed from this study. The AETS had to be compatible with the primary test facility and plan. The AETS was to be a separate system but integratable with the primary test facility. Design considerations included such parameters as type of material for the chamber, its size, number of subjects to be accommodated, placement of sensors and sample ports within or near the chamber, methods of monitoring subject's activity and gas concentrations as well as length of sampling lines, and methods of sampling.

The gas analysis methods used were to be the same as those used in the primary test facility and were to be performed by the same laboratories and by the same technicians. This procedure was necessary for accuracy in gas analysis, particularly when a sampling method is used. On-line continuous gas analysis for O₂ and CO would have required a separate set of analyzers, if a closed cage were used. Thus, unnecessary duplication of instrumentation and manpower was avoided.

A conceptual design for the AETS was developed based on these considerations, followed by final design and fabrication of the AETS. A test plan, integrated with and compatible with the primary test plan, was developed.

The AETS, including subjects and instrumentation, was transported and installed in the Boeing Company facility and in the UCB-Richmond Fire Test Facility at Richmond, California. Douglas participated in three large-scale burn tests of aircraft lavatories. Douglas operated the AETS, collected and analyzed the data resulting from the exposure of animals to evolving fire gases, and presented conclusions as to the relative toxicity of the combustion products as a function of the materials involved in the fire bases on the gas analysis data collected by the Boeing Company and NASA ARC.

The parameters analyzed included:

- Air temperature within the AETS cage.
- Activity of freely-moving subjects before and during exposure to evolved gases.
- Electrocardiographic and respiratory patterns before and during the test exposure on one instrumented subject.
- Correlation of the physiological and cage temperature data with the gas analysis data.

INSTRUMENTATION

It was found that a simple 1.9 cm (3/4 inch)-wide belt around the chest, containing two elastic sections, using velcro to fasten the ends, appeared to be retained by the subject with less apparent discomfort than some of the previous methods of fixation to the S.

Sensors

A piezo-electric respiratory transducer previously used for human subjects was incorporated into the center of the belt between the two elastic sections of equal length and two velcro sections distal to these. Figure 2 illustrates the structure of the electrode belt (E.B.).

Next, the design of the surface ECG electrodes was considered. Standard Beckman disposal Telectrodes were modified, tested, and found to be unsatisfactory. Loops of metal wire, through which the S's front legs were put were then fabricated. These were fastened to the outer ends of elastic sections. This technique showed promise but was temporarily rejected. The final electrode design, however, consisted of a rounded thumb tack drilled with four holes into which were soldered short sections of paper clips. These were filed a length suitable for penetration of the fur of the S, particularly after clipping. Figure 3 is a lateral view schematic of the ECG electrode.

The entire electrode was then gold-plated. To apply the electrode to the belt, the pin of the tack was pushed through the elastic section, one on either side of the respiration sensor after determining the proper placement in the belt after optimum stretching and fastening on the subject. Wires (teflon-coated) were then soldered to the pin, joined with the other wires from the other electrode, the respiration transducer, and the two ground wires from ECG and respiration, to form the umbilical cable to the plug at the ceiling of the cage. The length was sized to permit the subject free access to any portion of his compartment.

Cage Temperature

A non-linear thermistor, "400" Series, Yellow Springs Instrument Co., was used to sense cage temperature. The original design range was 10°C to 65°C. A constant d.c. current is passed through the thermistor, the resultant voltage is amplified and conditioned to be compatible with the FM magnetic tape recorder. A positive 1.4 vdc corresponds to 10°C and 65°C is indicated by a negative 1.4 vdc. A calibration curve of voltage vs temperature for use in data reduction in Figure 1 of the Appendix.

After the Boeing test in which the cage temperature reached approximately 92°C, the temperature range was expanded to record from 0°C to 100°C although the calibration record remained the same.

Electrocardiogram

The ECG signal conditioner amplifies frequencies from 1.0 Hz to 2000 Hz in order to provide complete recording of the rat cardiac frequencies. The signals are amplified about 4000 times (72 dB) and adjusted to the tape recorder input levels (± 1.4 vdc).

The ECG pre-amplifier consists of a transistor differential input stage to achieve high input impedance and low noise. Operational amplifiers are used in the output to increase signal level.

Respiration

The frequency design range for respiration is from 0.5 Hz to 500 Hz. Figure 2 of the Appendix shows the circuit diagram for the respiratory electronics. Respiration is measured with a piezo-electric transducer mounted in the electrode belt. The transducer is responsive to expansion and contraction of the rib cage. Signal conditioning electronics consist of an impedance buffer which isolates the transducer from the low impedance recorder and signal amplification to provide proper signal level to the tape recorder. Figure 4 in the text illustrates typical laboratory recordings of ECG and respiration.

Subject Activity

The original concept for monitoring physical activity of the mice in the second compartment was simply to record their activity via cinematography or video-tape. In the Boeing test, an exercise wheel and a teeter-totter were provided. The wheel was used vigorously by the S_s, but the teeter-totter appeared to be of little value. One of the simplest methods was found to be observation of the S_s climbing to the top of the cage. S's inability to maintain the inverted position and falling to the cage floor appears to be an adequate endpoint for functionability. Videotape recording of this test was quite useful for monitoring activity.

During the development of the electrode belt and during the Boeing test, it was found that the ECG and respiratory records were very useful in indicating the relative level of physical activity of the rat by the noise level generated in the ECG by his movements. The noise shown in the recording is roughly proportional to the degree of activity. Indications are (unverified as yet) that terminal spasticity and convulsions can be identified also. Additional research will be needed for verification.

Recording

ECG, respiration and cage temperature are recorded on any standard multi-channel magnetic tape recorder. In the Douglas Biomedical Laboratory, a Precision Instrument 7-channel 1.27 cm (1/2-inch) FM tape recorder at 19.05 cm/s (7-1/2 ips) is used. At Boeing a standard 2.54 cm (1-inch) FM tape recorder at 38.1 cm/s (15 ips) was used to be compatible with their data acquisition system. The tapes are returned to the Douglas Biomedical Laboratory, reproduced on the 8-channel strip chart of a Beckman Type SII Dynagraph Recorder utilizing 4 channels to record ECG, unfiltered respiration, filtered respiration, and cage temperature (Figure 6). The temperature channel is used to indicate various events, e.g., start of test, ignition and other physical events by utilizing the T° calibrate/operate switch on the electronics box and a code developed for this purpose.

Data Analysis

Physiological and temperature data are analyzed from the strip chart. Parameters examined and end-points observed include changes in heart rate (HR), such as bradycardia (slow HR), cardiac arrhythmias and arrest, respiratory pattern changes, changes in respiratory integration time and respiratory arrest. Physical activity of the instrumented subject is also observed as EMG noise in the ECG baseline and this has been observed as being roughly proportional to the level of activity.

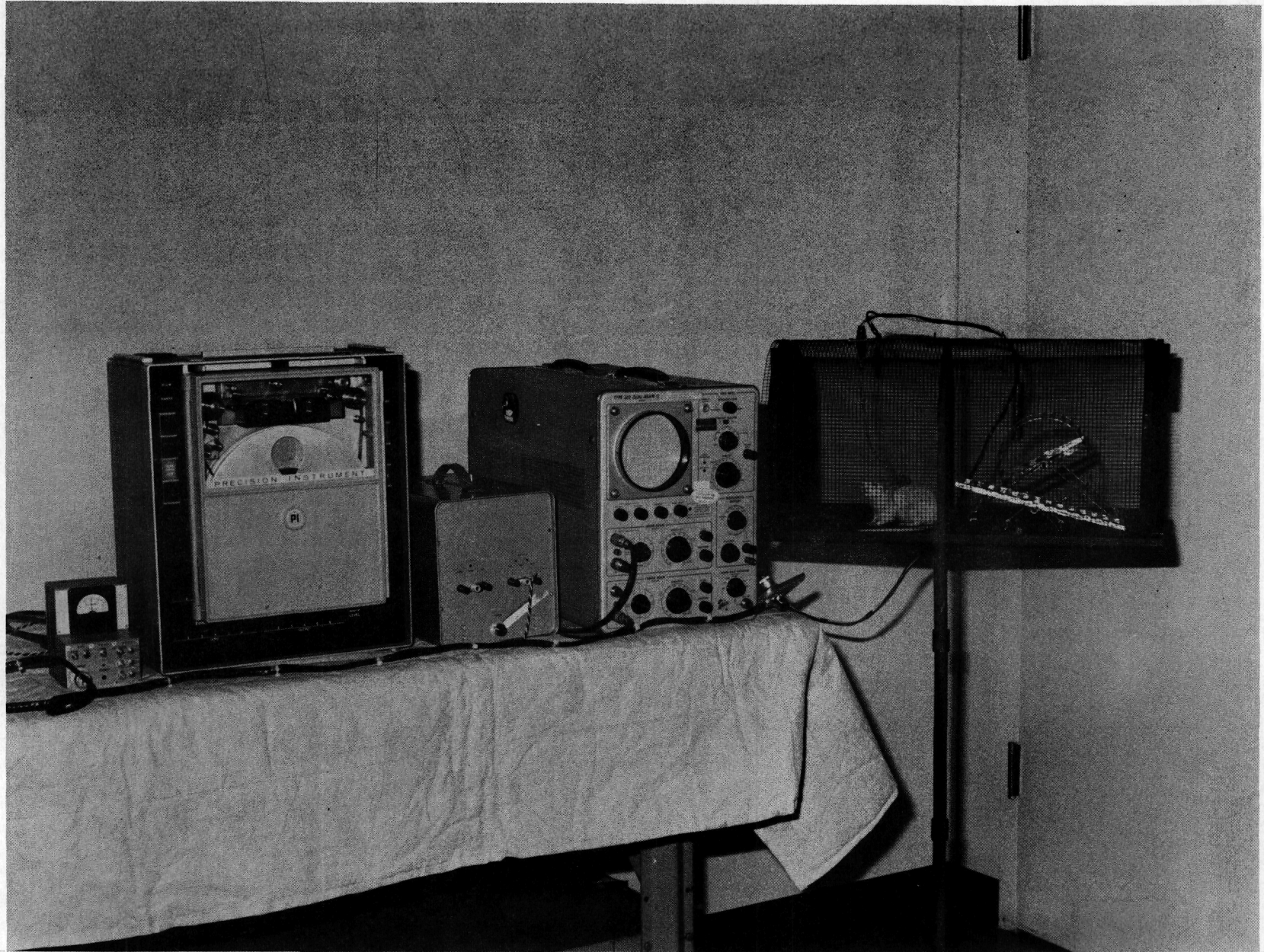

FIGURE 1. EXPOSURE CAGE ON ARTICULATED SUPPORT STAND.

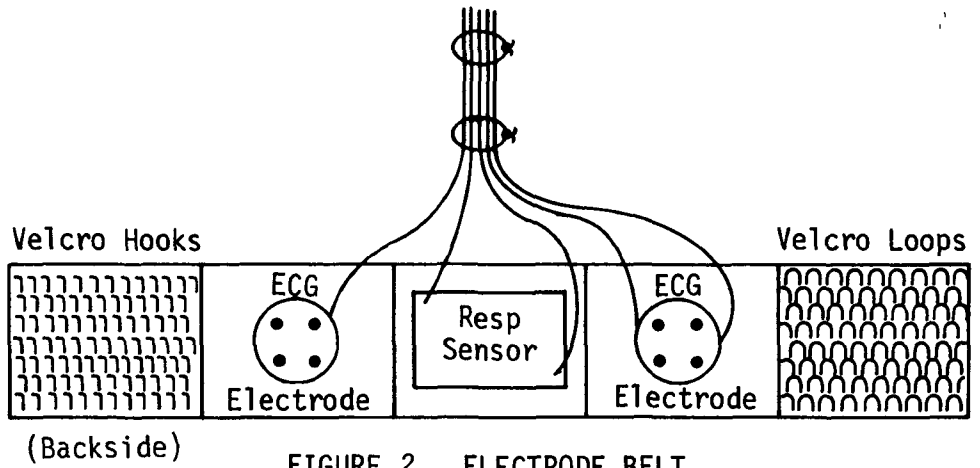

FIGURE 2. ELECTRODE BELT STRUCTURE

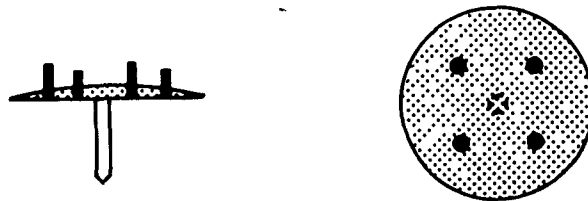

FIGURE 3. LATERAL AND TOP VIEW OF ECG ELECTRODE

COMMENTS ON THE BOEING TEST, JUNE 11, 1975

, in preparation for the Boeing test at Seattle, an AETS checkout test was run in the MDC Cabin Fire Simulator (CFS) facility at A3 (Huntington Beach). The fire source was 4.55 Kg (ten pounds) of shredded newspaper contained in two expanded metal baskets and ignited by means of a nichrome wire inserted into the basket located on the floor. The AETS was outside the simulated marsonite lavatory and connected with the lavatory enclosure by a 1.9 cm (3/4 inch) flexible hose approximately 38.1 cm (15 inches) long. The duct entered the AETS through a connector in the sealed plastic (polyethylene) covering of the cage, making it into a closed system for this test. The effluent duct discharged into the exhaust duct from the lavatory enclosure. The AETS air flow was regulated by the same exhaust pump and a control valve inserted into the effluent duct between the exposure cage and lavatory exhaust duct.

The AETS functioned as designed in this preliminary checkout test conducted in the MDC CFS.

The rat's responses to the fire gases are evident in 1.3 minutes after ignition. Cardiac arrhythmias continue for 4-5 minutes. At ten minutes into the test the fire was extinguished by flooding the compartment with nitrogen (N₂). Again, severe bradycardia and arrhythmias occurred in about one minute after N₂ was introduced. Hypoxia was undoubtedly a major factor in producing this effect. Cage temperature profile is shown in Figure 5. Table 2 summarizes the physiological effects and sequence.

The AETS was packed and transported to Boeing, Seattle, and the system prepared for the burn test. Checkout went smoothly until the subject chewed some of the electrode wires in two on the day of the test. Repairs were quickly made, and the system was again checked out and found to be working satisfactorily.

The test began on schedule and burned for the full allotted 30 minutes, then was extinguished with CO₂. Both rat and mice (in the activity side of the cage) died at approximately the 18th minute. All subjects were obscured by smoke at 16 minutes and the instrumented S's record indicated death at approximately 18 minutes. However, at about 12 minutes the mice were fairly incapacitated as indicated by their falling behavior in the wheel and by their dropping to the floor from the top of the cage. Table 2 summarized the physiological effects in this burn test. Figures 6 through 13 show the span from normal ECG and respiration to cardiac arrest, as a function of time. Fire gases and O₂ are shown in Figures 14 through 17 (9). Figure 21 shows the enclosure temperature. Figure 22 illustrates the arrangement of the "airline" type waste used as an ignition source and Figure 17 depicts the position and general arrangement of the AETS. The correlation of the physiological effects and the gas analysis data was reported in a "Special Report of the Boeing Test", a copy of which is included in the Appendix of this report for sake of completeness.

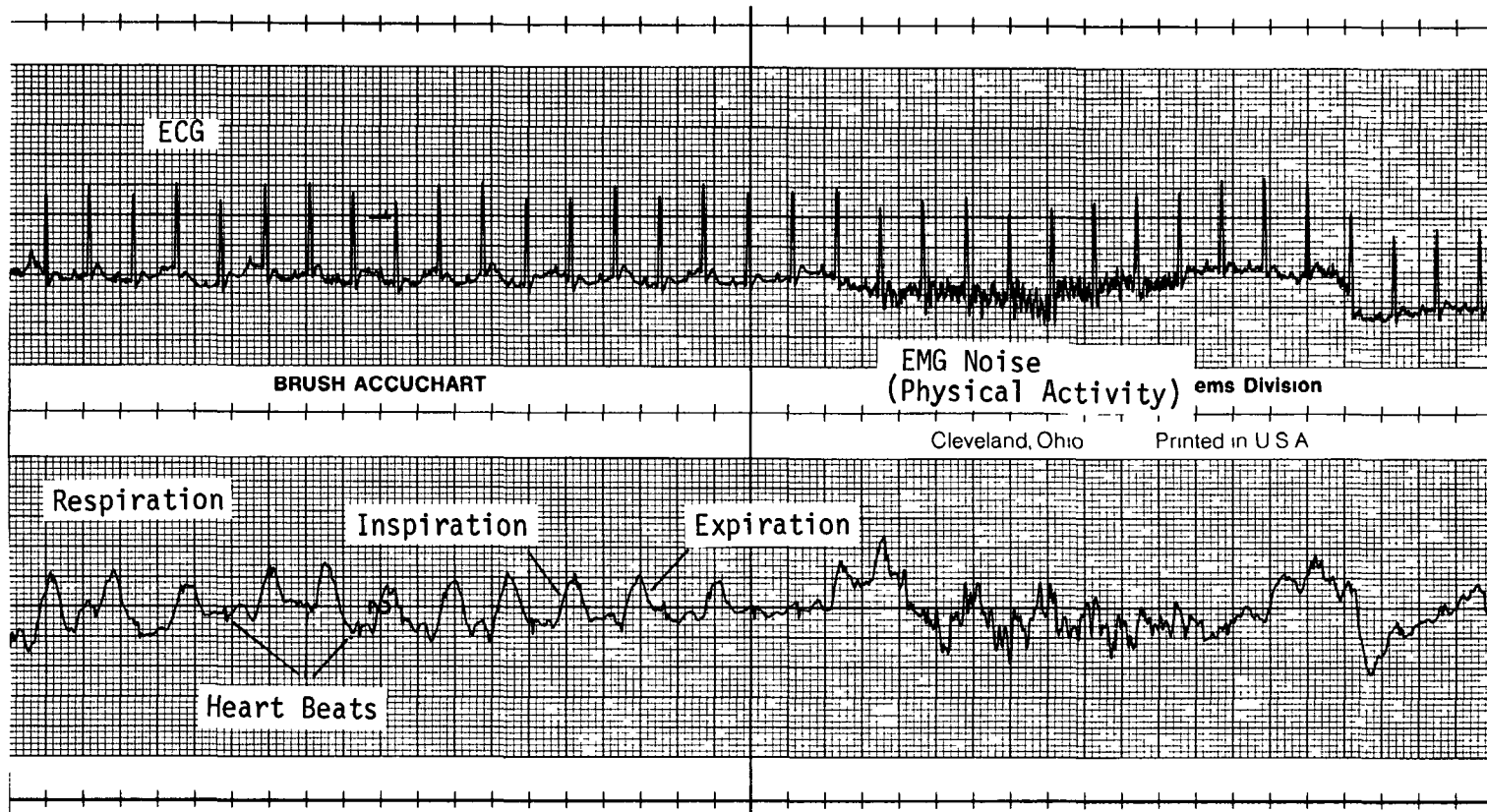

FIGURE 4. LABORATORY RECORDINGS OF ECG AND RESPIRATION ILLUSTRATING EMG

AETS CAGE CFS BURN TEST -

FIRE SOURCE: 4.55 Kg (10 LB) SHREDDED NEWSPAPER

224

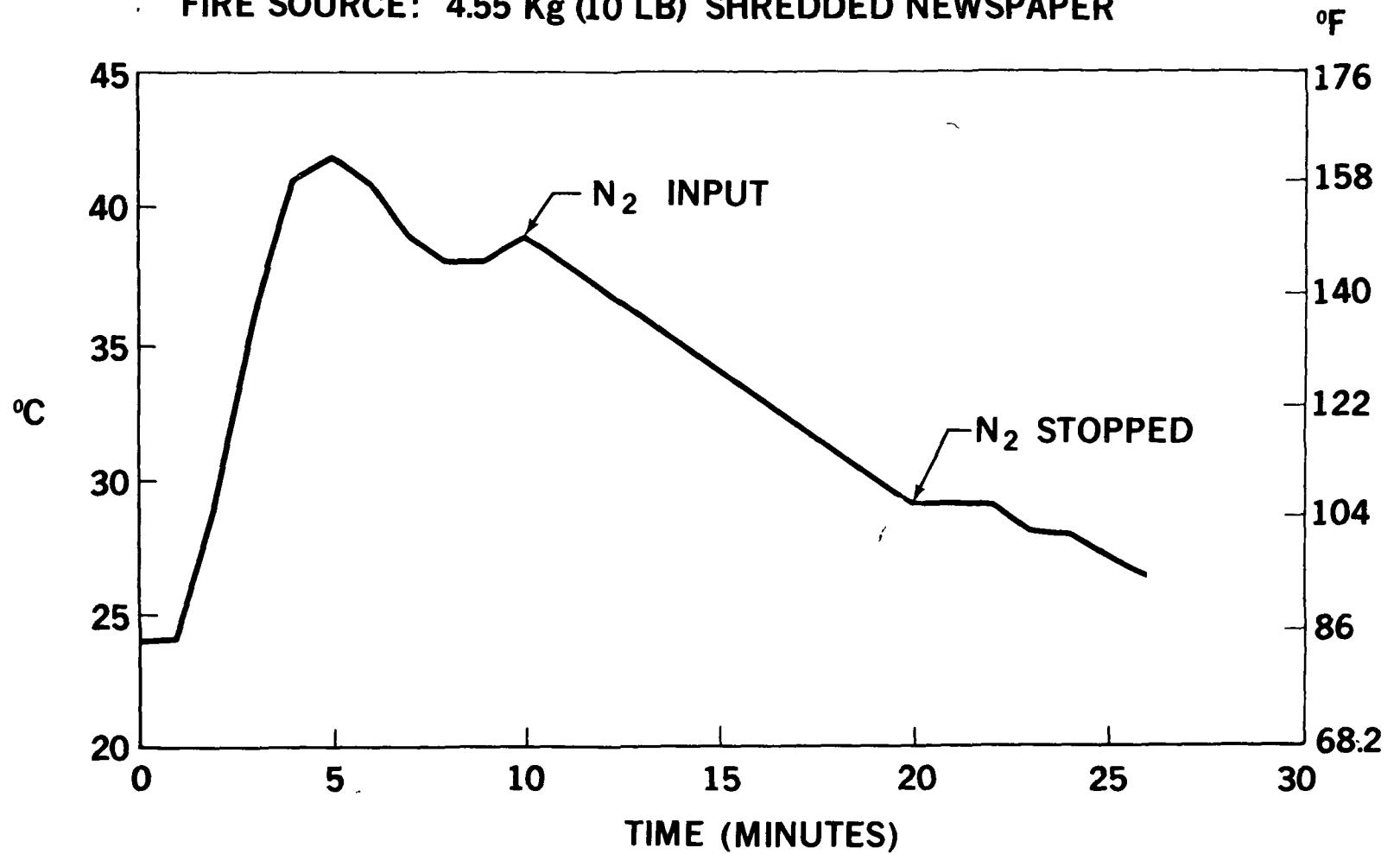

FIGURE 5. TEMPERATURE PROFILE, CFS TEST

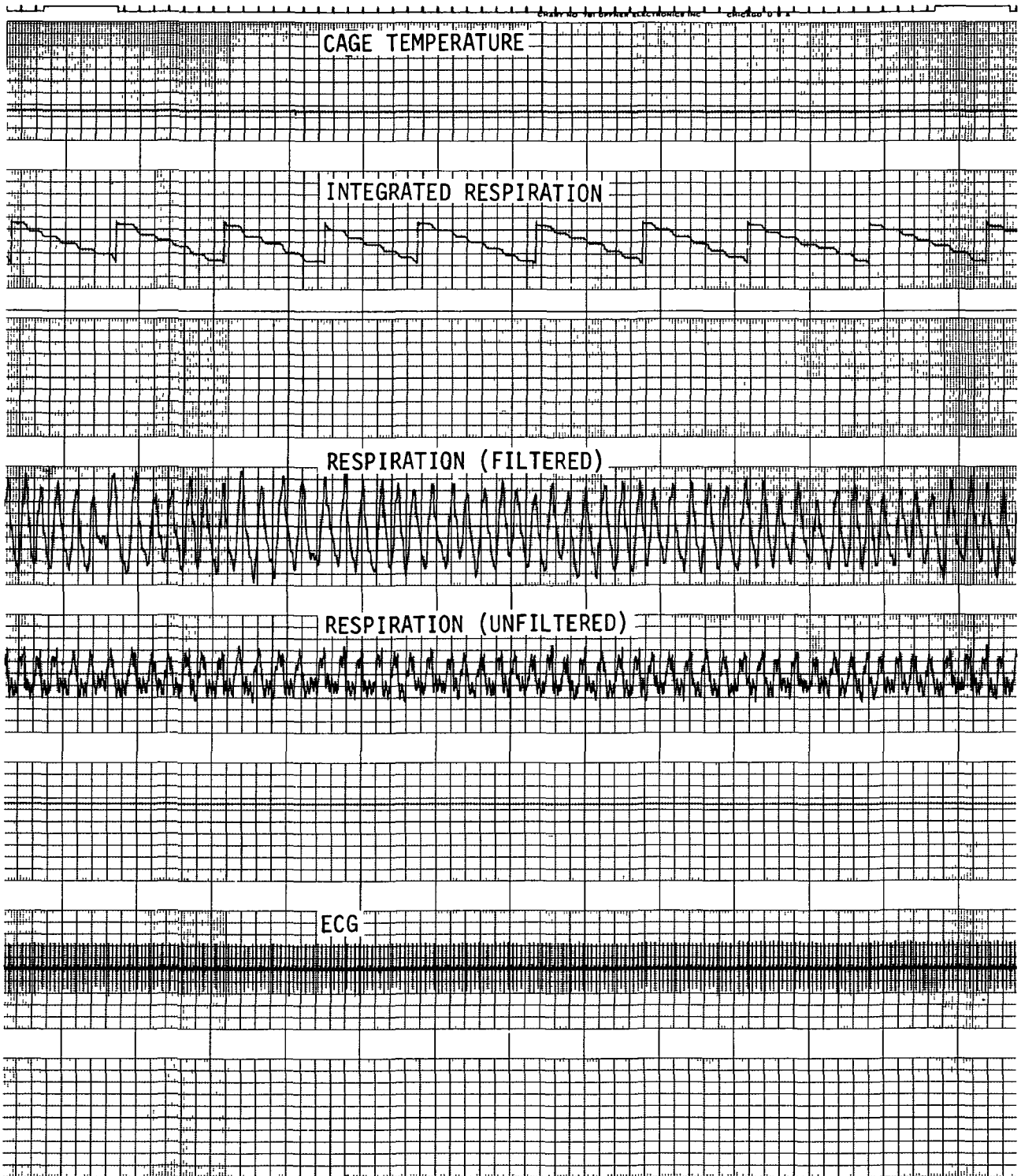

FIGURE 6. REPRODUCED BOEING TEST PHYSIOLOGICAL DATA

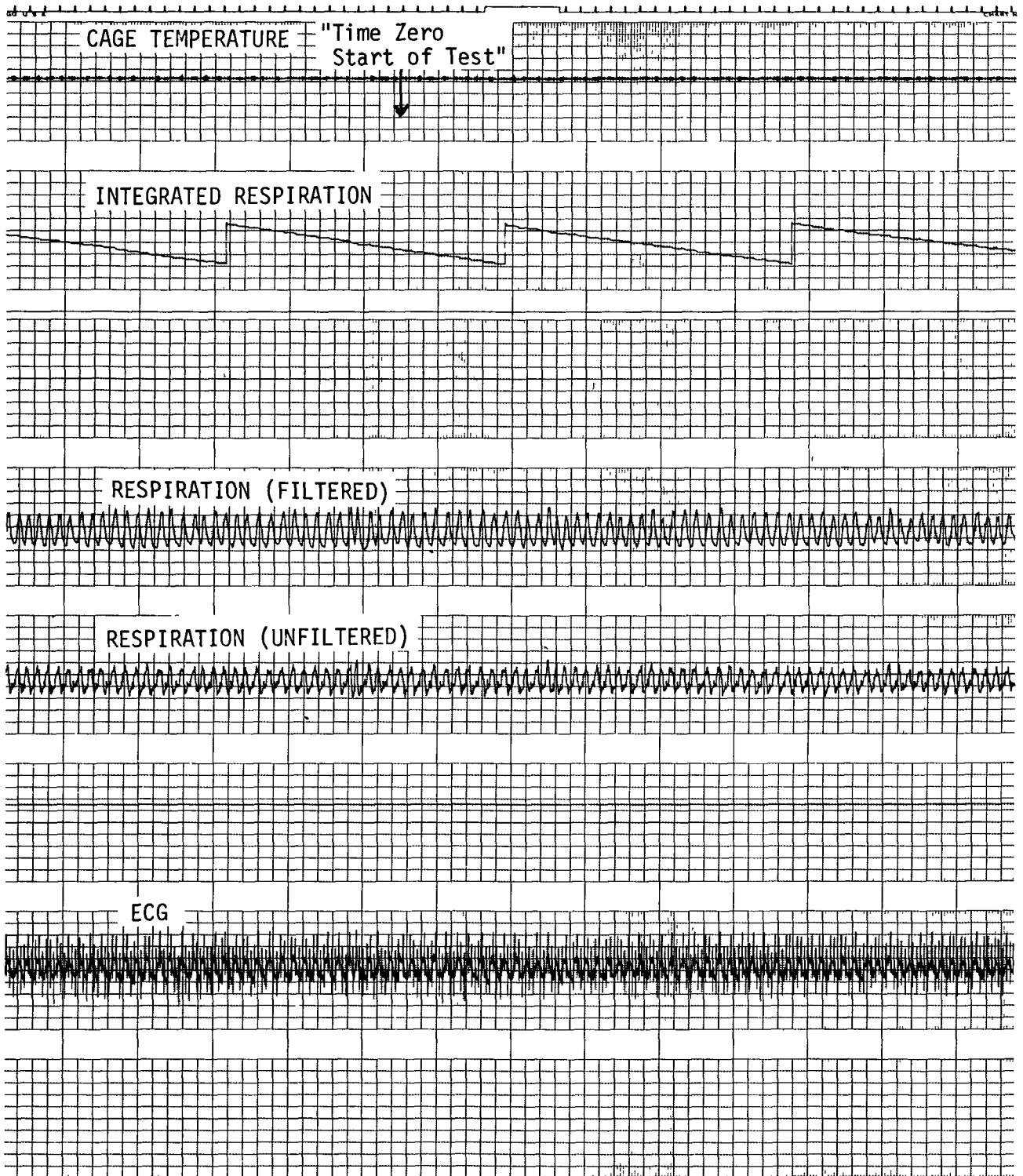

FIGURE 7. REPRODUCED BOEING TEST PHYSIOLOGICAL DATA

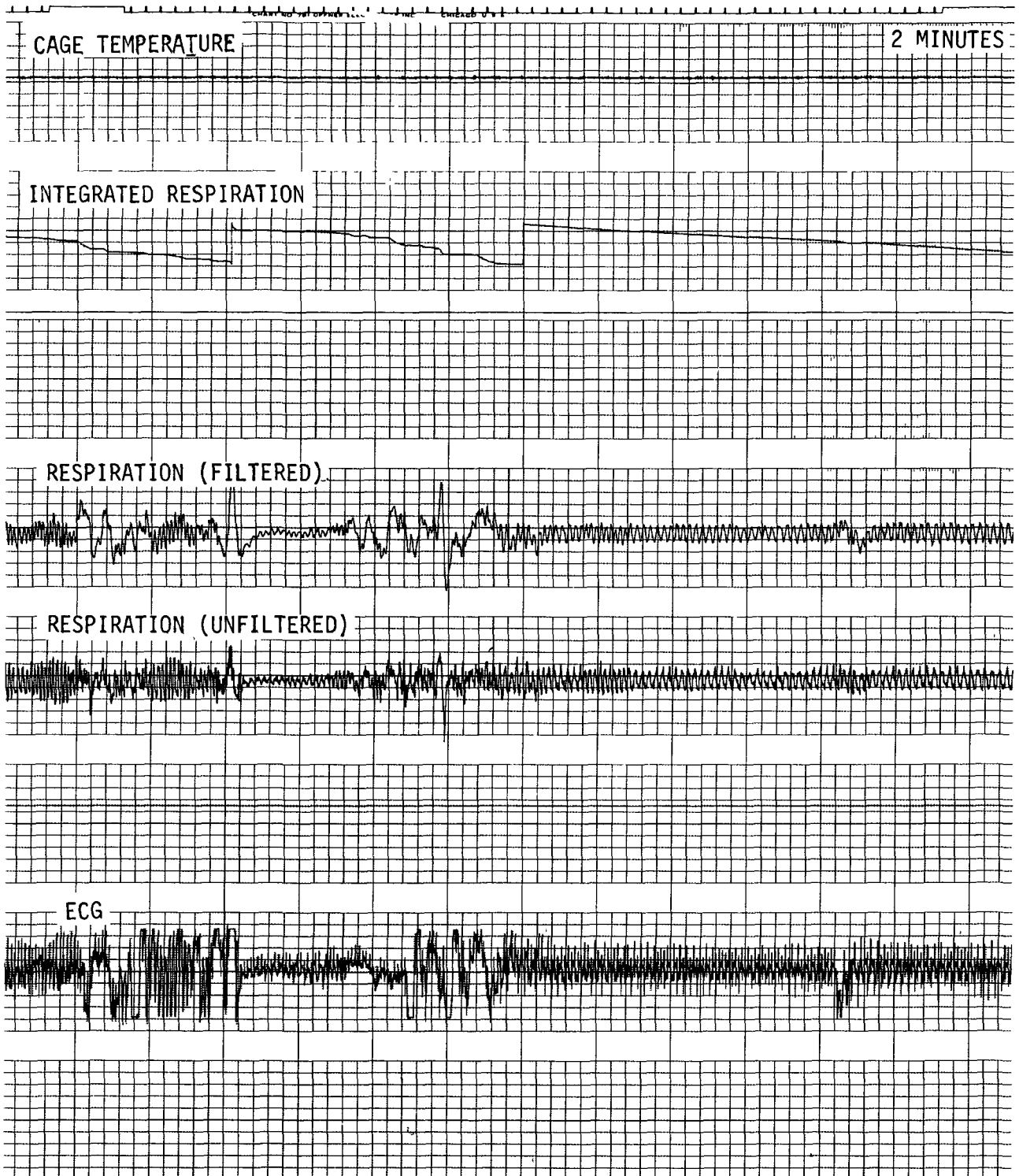

FIGURE 8. REPRODUCED BOEING TEST PHYSIOLOGICAL DATA

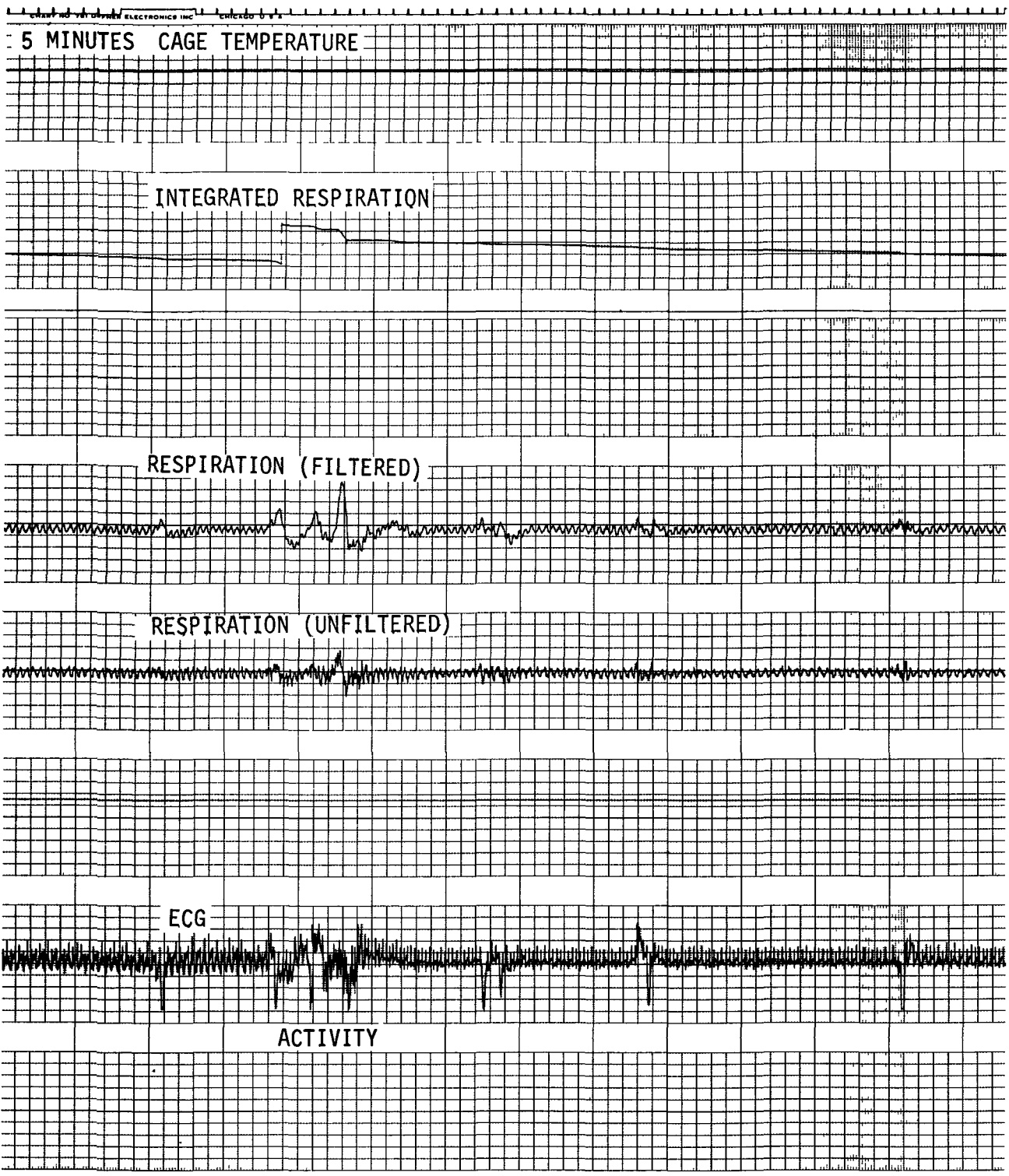

FIGURE 9. REPRODUCED BOEING TEST PHYSIOLOGICAL DATA

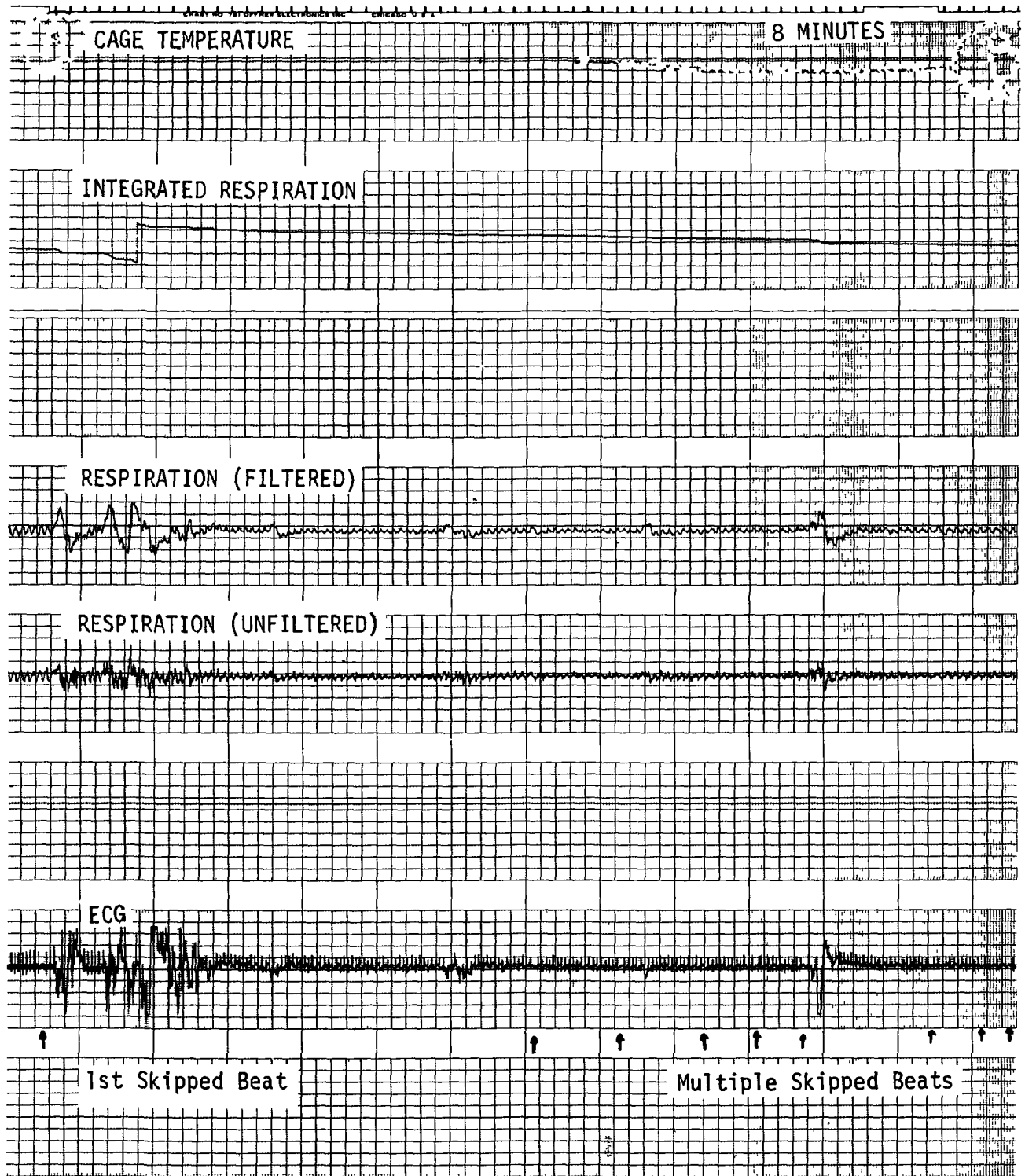

FIGURE 10. REPRODUCED BOEING
TEST PHYSIOLOGICAL
DATA

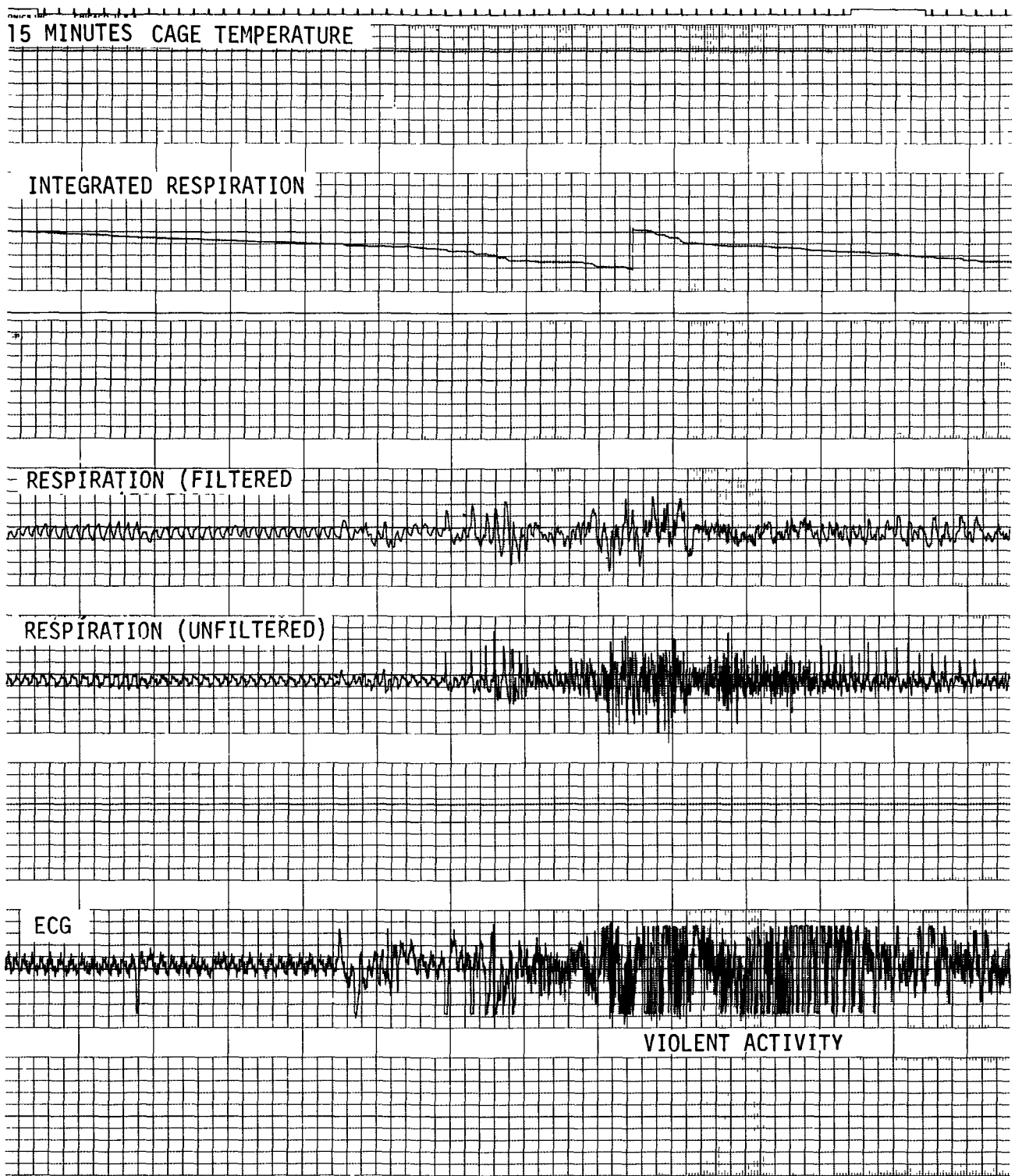

FIGURE 11. REPRODUCED BOEING
TEST PHYSIOLOGICAL
DATA

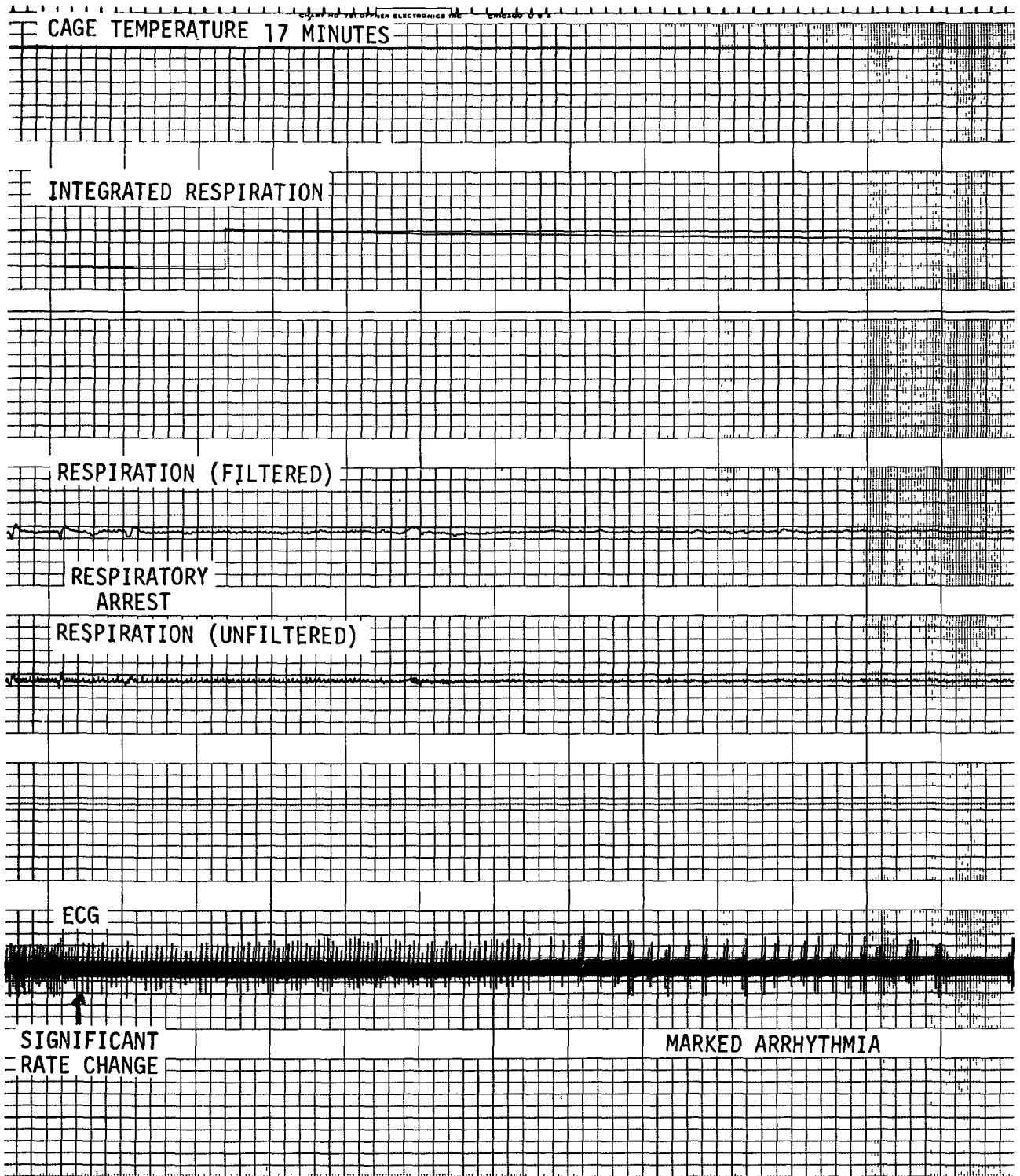

FIGURE 12. REPRODUCED BOEING
TEST PHYSIOLOGICAL
DATA

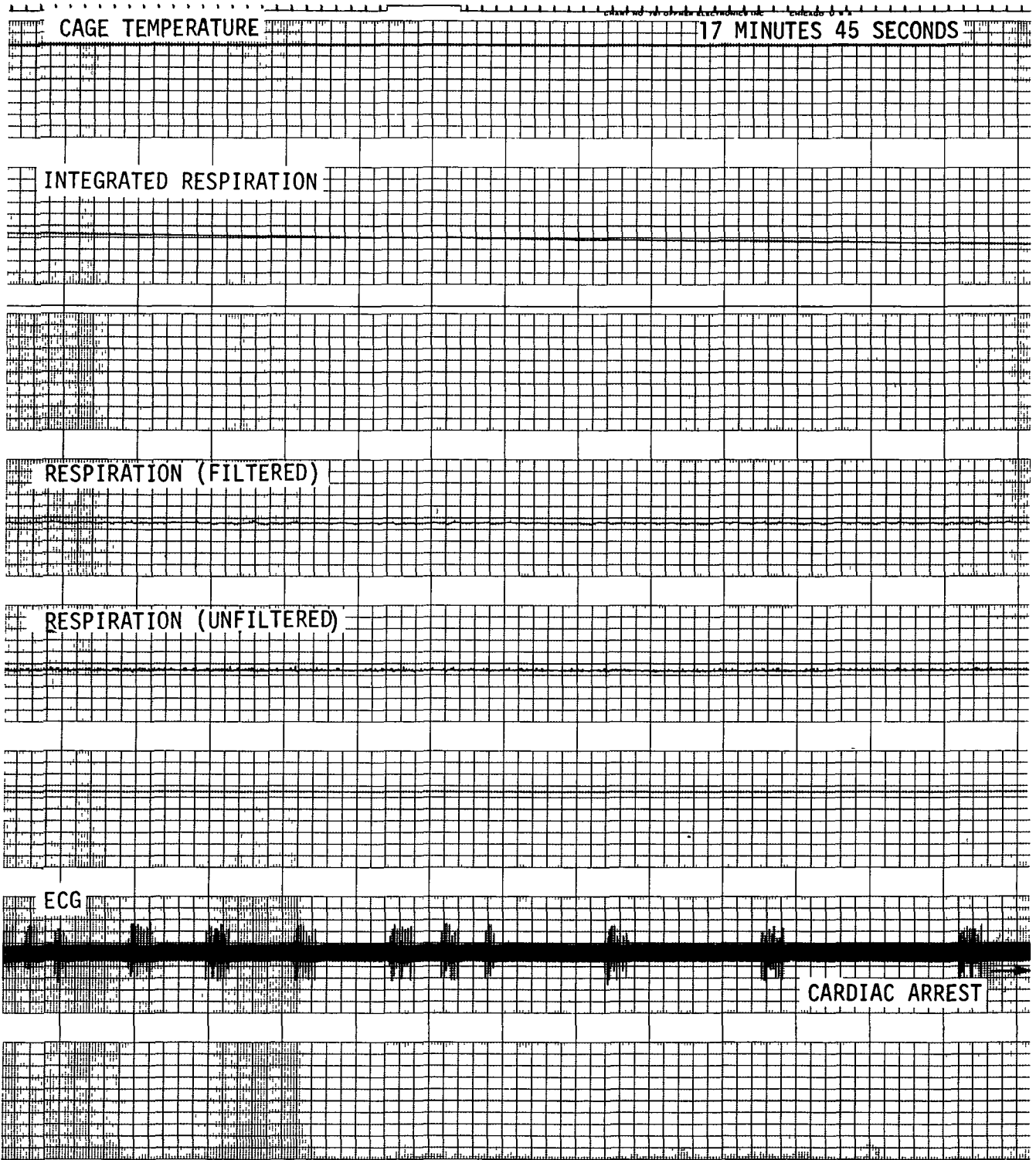

FIGURE 13. REPRODUCED BOEING
TEST PHYSIOLOGICAL
DATA

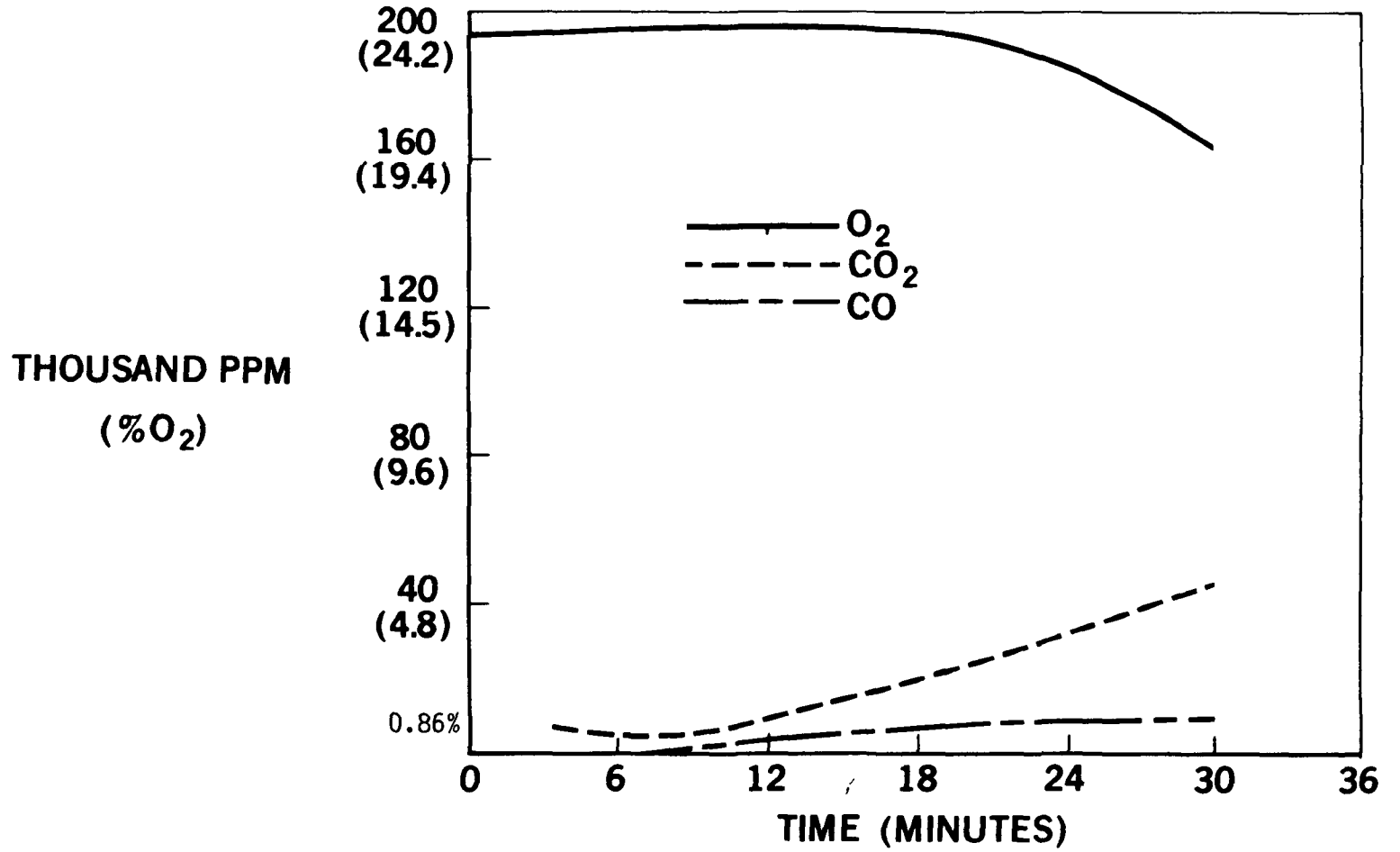

FIGURE 14. BOEING TEST DATA
MAJOR GASES IN
ENCLOSURE

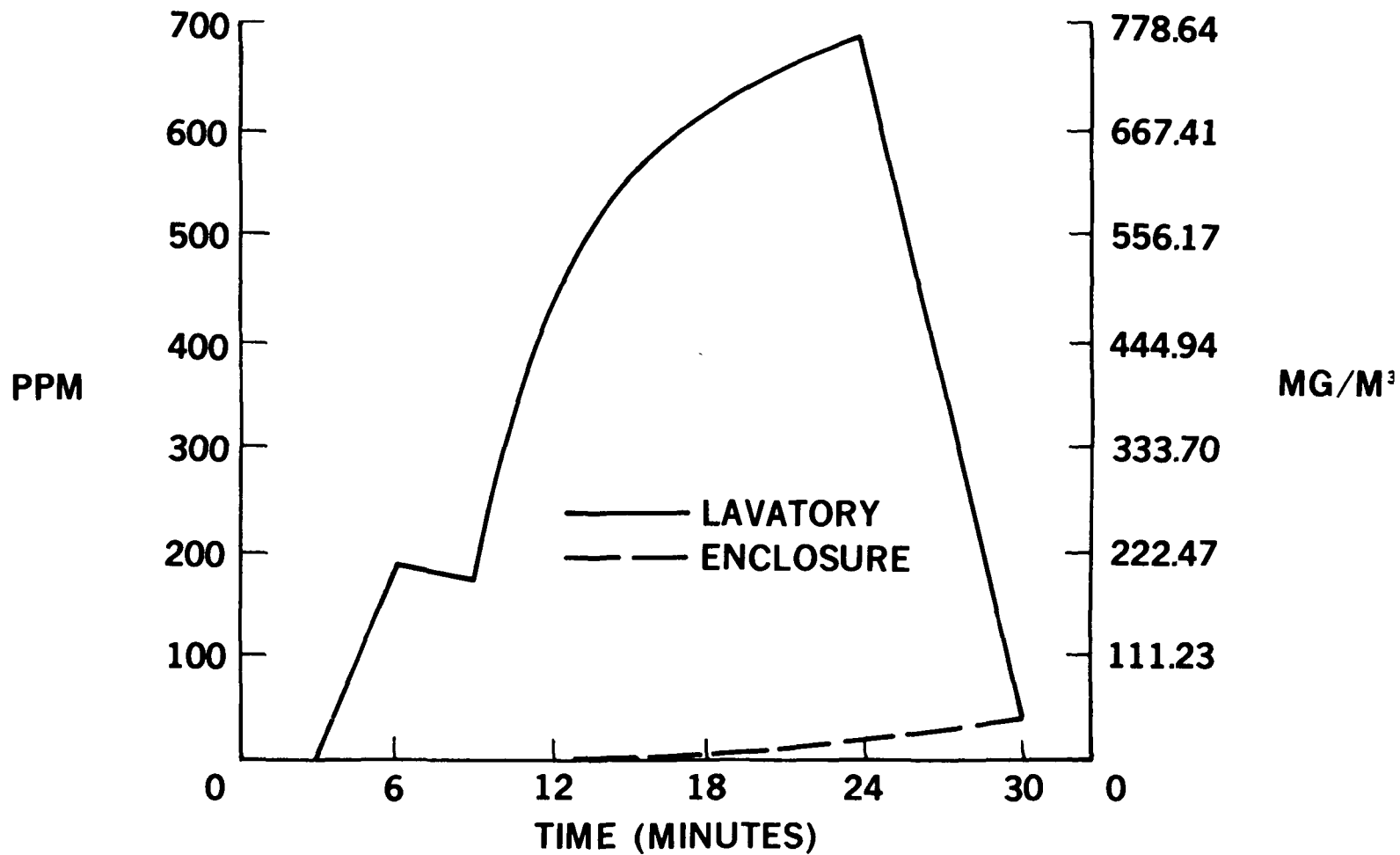

FIGURE 15. BOEING TEST DATA
CONCENTRATION OF HCN

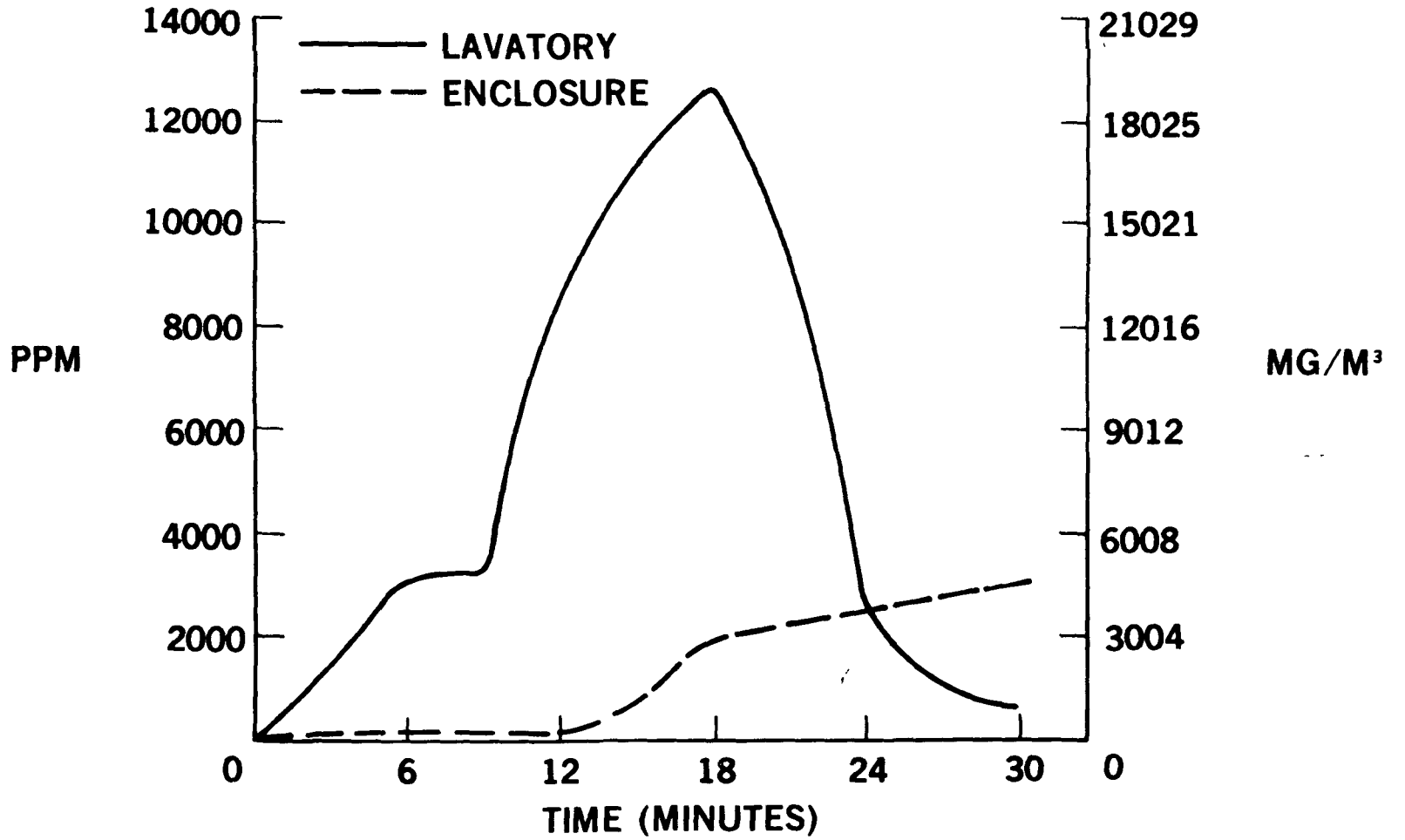

FIGURE 16. BOEING TEST DATA
CONCENTRATION OF HCl

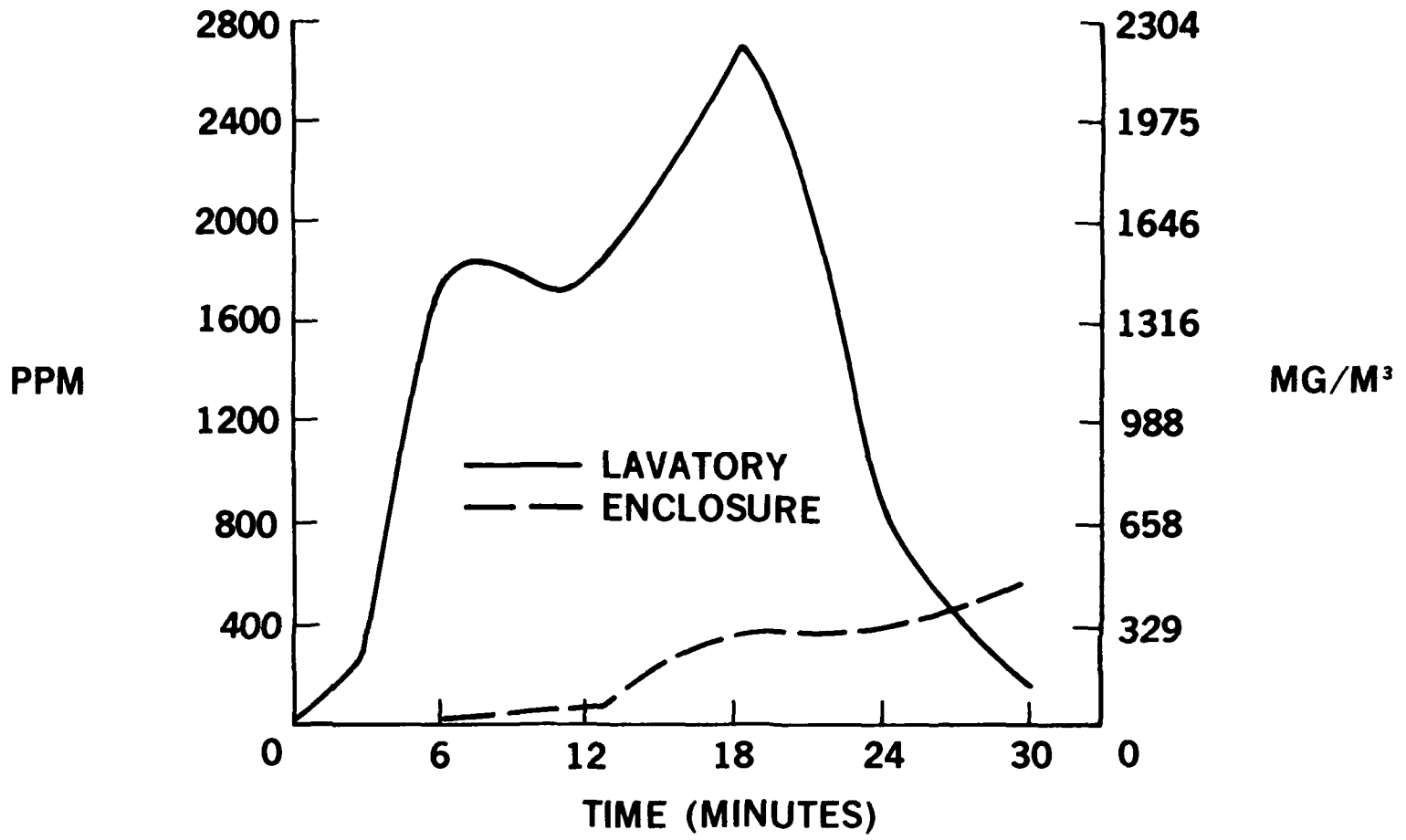

FIGURE 17. BOEING TEST DATA
CONCENTRATION OF HF

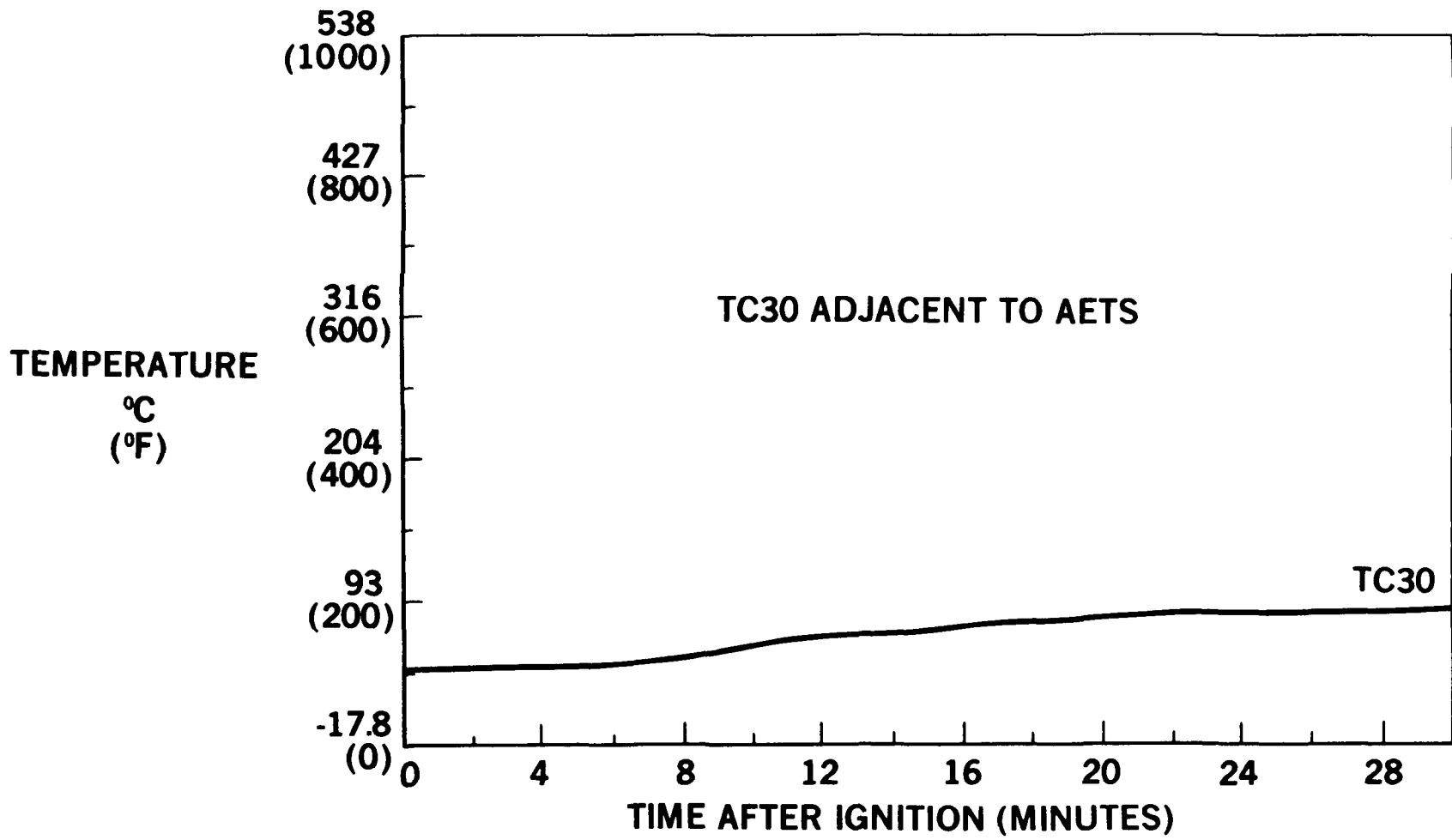

FIGURE 13. BOEING TEST DATA
AIR TEMPERATURE IN
ENCLOSURE

<u>PHYSIOLOGICAL EFFECT</u>	<u>MINUTES INTO TEST</u>
CARDIAC ARRHYTHMIA BEGAN AT	1.3
BRADYCARDIA (SLOWING OF HEART RATE) FROM 520 BPM TO 110 BPM NORMAL RATE \approx 400-450	1.5
HEART RATE (H.R.) FASTER AND IRREGULAR	2.6
H.R. MORE REGULAR	5.5
TEST FIXTURE FLOODED WITH LIQUID N ₂	10.0
MARKED BRADYCARDIA AND ARRHYTHMIA	11.0
HIGH RESPIRATORY AND PHYSICAL ACTIVITY	11.5
BRADYCARDIA AND ARRHYTHMIA	13.5
HIGH H.R. WITH ARRHYTHMIAS	17.0
STOPPED N ₂ INFLOW	20.0
HIGH RESPIRATORY AMPLITUDE	20.5
CARDIAC RHYTHM RECOVERING	25.0
SUBJECT REMOVED. SURVIVED, IN FAIR CONDITION	27.0

TABLE 1 CFS PHYSIOLOGICAL
DATA SUMMARY

<u>ECG/RESPIRATION</u>	<u>MINUTES INTO TEST</u>
FIRST ARRHYTHMIA (SKIPPED BEAT)	7.65
FOURTEEN MORE SKIPPED BEATS BY	9.0
TWO MORE SKIPPED BEATS BY	10.0
ECG AMPLITUDE DIMINISHED	10.0
BRADYCARDIA AND RESPIRATORY ARREST	17.0
CARDIAC ARRHYTHMIAS, MARKED BRADYCARDIA, SPORADIC ARREST FOR 2-7 SECONDS	17.25
PERMANENT CARDIAC ARREST	18.0

THE ECG AND RESPIRATORY RECORDS ALSO APPEARS TO REFLECT
PHYSICAL ACTIVITY OF THE INSTRUMENTED SUBJECT.

* CAGE TEMPERATURE WENT OUT OF SCALE. MAXIMUM TEMPERATURE
DESIGNED FOR WAS 65° C. BOEING RECORD SHOWED 196° F (91° C) .

TABLE 2 BOEING TEST
PHYSIOLOGICAL DATA
SUMMARY

DISCUSSION

The physiological responses which have been observed in the instrumented subject in these tests, principally in the Boeing test and in the prior MDC CFS test, include:

1. Cardiac responses - bradycardia (slow heart rate), arrhythmias possibly of two or three types, and cardiac arrest.
2. Respiratory responses - reduction of amplitude, change of rate, reduction of minute volume.
3. Electromyographic responses (EMG) - of the torso. During physical activity of the subject, characteristic changes occur in the ECG baseline which have been related to muscle activity, in the laboratory and in the burn tests. Activity level can be estimated from the magnitude of EMG noise generated in the ECG record. It may be possible to identify convulsive activity, but this premise requires laboratory verification.

The activity responses observed in the mice in the second compartment of the Mark I cage were:

1. Vigorous activity, initially, on the exercise wheel and climbing the sides and under side of the cage mesh.
2. Stumbling and falling on the exercise wheel and riding up with the turning wheel nearly to the top of the turn. This effect was observed at approximately eleven minutes. This may be called the TUF.
3. Dropping from the underside of the cage top at approximately twelve minutes, apparently unable to muster the strength or coordination to hang on to the mesh as they had been doing. This may also be regarded as the TUF. Normally, these S_5 were able to climb up, over and down again with ease.
4. Convulsive jumping at approximately fifteen minutes.
5. Collapse and sporadic convulsions at sixteen minutes (observed after 16 minutes).

The behavior of the mice follows the pattern observed by most investigators, is a valid and useful method of monitoring, and little more needs to be said about this aspect. However, the physiological records when correlated with specific events of the test such as temperature increase, the time of appearance of the various fire gases (see Special Report, Appendix), and their rise in concentrations in time, give rise to certain questions regarding the physiological mechanisms of the recorded responses. Some questions are raised

regarding the mechanisms of similar cardiac responses when the S_5 are exposed to fire gases, simple hypoxia, or various extinguishing agents such as nitrogen, CO_2 , and the Halons. Why do all these different species produce cardiac effects that are so similar? Are the responses mediated by the same or different physiological mechanisms? And what are the mechanisms involved?

In the Boeing test the responses appeared to correlate with the build-up of HF and HCl in the enclosure. There was no O_2 deficit in the enclosure, so if hypoxia were the basic cause of cardiac effects, it probably was due to the presence of fire gases, or greatly diminished respiration from the irritating smoke, or both. Sporadic increases in respiratory rate and amplitude with or without an increase in physical activity, suggest that this may be the correct hypothesis. On the other hand, in the MDC CFS test, the rapidity of the onset of cardiac response, probably before hypoxia could have caused it, suggests that another mechanism may be in action. Other observations in MDC fire testing tends to support the latter hypothesis.

Other questions arise: Are the rats's cardio-respiratory responses similar to those expected in the human? Which is more responsive to these stimuli? Can the human response be scaled 1:1, or will it be different and in which direction?

CORRELATION OF PHYSIOLOGICAL AND GAS ANALYSIS DATA

1. There was no appreciable reduction of O_2 (20.+) in the enclosure by the time of death (TOD) at 18 minutes.
2. There was no significant increase in CO_2 (2.0%) in the enclosure by the time of death at 18 minutes.
3. There was no significant increase in CO (0.33%) in the enclosure by the time of death at 18 minutes. CO first appeared in the enclosure at approximately 10 minutes and reached approximately 3300 ppm (0.33%) by 18 minutes (TOD) giving approximately 8 minutes of exposure at low concentrations. This undoubtedly made a minor contribution to the hypoxia.
4. HCN had barely made its appearance in the enclosure by 18 minutes (TOD). Therefore, HCN appears not to have been a significant factor.
5. HF appeared in enclosure at 6 minutes, slowly increased linearly, to approximately 65 ppm by 13 minutes, then rapidly increased to approximately 325 by TOD (18 minutes).
6. HCl was barely detected until 12 minutes when it rose sharply to nearly 2000 ppm by TOD (18 minutes).
7. Enclosure temperature remained fairly constant at approximately 100°F for 6 minutes, rose to 48.9°C (120°F) at 8 minutes, 60.°C (140°F) at 12 minutes and to 71.1°-73.8°C (160-165°F) at 18 minutes (TOD).

Discussion

Thus, three known factors appear to be the most significant in the death of the subjects.

1. Cage temperature increase to approximately 73.8°C (165°F) at 18 minutes (TOD).
2. Sudden increase in HCl concentration from near zero at 12 minutes to nearly 2000 ppm at 18 minutes (TOD).
3. Sudden increase in HF concentration from approximately 65 ppm at 12 minutes to approximately 350 ppm at 18 minutes (TOD).

It is very probable that these three factors exerted a synergistic effect to cause the expiration of subjects. The probable mechanism is most likely the onset of severe hypoxia, in spite of adequate O₂ present in the enclosure, produced by severe pulmonary edema and/or hemorrhage induced by the irritant and corrosive action of HCl and HF. High environmental temperature undoubtedly intensified the reactivity of HCl and HF. The possibility of other toxic gases which were not measured for, e.g., NO₂, SO₂, aldehydes, etc., should not be discounted. Also, the possibility of the "adrenalin effect" in the presence of halogenated hydrocarbons should be considered.

Conclusions

On the basis of the information available, and realizing that unknowns are involved, it can be tentatively concluded that the subjects expired from the combined hypoxic effects of primarily HCl, HF, and high temperature, with minor contributions to hypoxia being made by CO and possibly other unknown gases.