

NASA  
TP  
1343-  
v.1  
c.1

NASA Technical Paper 1343

LOAN COPY: RETURN TO  
AFWL TECHNICAL  
KIRTLAND AFB,



# Lubrication and Failure Mechanisms of Molybdenum Disulfide Films

## I - Effect of Atmosphere

Robert L. Fusaro

DECEMBER 1978





NASA Technical Paper 1343

# Lubrication and Failure Mechanisms of Molybdenum Disulfide Films

I - Effect of Atmosphere

Robert L. Fusaro  
*Lewis Research Center*  
*Cleveland, Ohio*

**NASA**

National Aeronautics  
and Space Administration

**Scientific and Technical  
Information Office**

1978

# LUBRICATION AND FAILURE MECHANISMS OF MOLYBDENUM DISULFIDE FILMS

## I - EFFECT OF ATMOSPHERE

by Robert L. Fusaro

Lewis Research Center

### SUMMARY

Friction, wear, and wear life of molybdenum disulfide ( $\text{MoS}_2$ ) films rubbed on 440C HT (high temperature modified) steel disks were studied in a pin-on-disk sliding friction apparatus. The sliding surfaces were optically observed through a microscope to study the transfer and flow properties of  $\text{MoS}_2$  films. These observations were made at preset intervals throughout the wear lives of the films by stopping the tests and removing the specimens from the apparatus.

A thin, coalesced film of  $\text{MoS}_2$  formed on each sliding surface and plastically flowed between the sliding surfaces. This was the lubricating mechanism. Transfer films formed "dynamically": Molybdenum disulfide built up in the entrance region of the rider scar, became compacted, and eventually coalesced into a very thin film in the contact region as it flowed toward the exit region.

The  $\text{MoS}_2$  films were evaluated in three atmospheres: moist air (10 000-ppm  $\text{H}_2\text{O}$ ), dry air (<20-ppm  $\text{H}_2\text{O}$ ), and dry argon (<20-ppm  $\text{H}_2\text{O}$ ). The primary failure mechanism was the transformation of bright, metallic-colored, coalesced films of  $\text{MoS}_2$  to a black, powdery material. The rate of  $\text{MoS}_2$  transformation was lowest in dry argon and highest in moist air. The wear life was longest in dry argon and shortest in moist air. And the rider wear rate was lowest in dry argon and highest in moist air. The friction coefficient was higher in moist air (0.08) than in dry air or dry argon (0.02).

In dry argon, there was no optical evidence of the transformation of  $\text{MoS}_2$ , and a second failure mechanism was found to be operating. In this case, sliding cracked and spalled the metallic-colored, coalesced film on the wear track. This, coupled with the fact that the  $\text{MoS}_2$  tended to flow radially outward, gradually depleted the film and produced fine, powdery, metallic wear debris.

## INTRODUCTION

Molybdenum disulfide ( $\text{MoS}_2$ ) is one of the most widely used solid lubricants. A considerable amount of research has been conducted on its friction properties and the reasons for its good lubricating behavior. Johnson (ref. 1), Winer (ref. 2), and Farr (ref. 3) have written excellent reviews on the history, uses, and fundamental knowledge of  $\text{MoS}_2$  as a lubricant.

Many studies have been conducted on the lubrication mechanisms of  $\text{MoS}_2$  films. Most of these studies have been on a molecular level; that is, they have related the good lubricating properties of  $\text{MoS}_2$  to its hexagonal crystal structure and covalent nature (refs. 2 and 3) or to the fact that  $\text{MoS}_2$  has a highly polarized surface that adheres well to metals (ref. 4).

Many studies have also been conducted on the failure mechanisms of  $\text{MoS}_2$  films. Failure has been related to the chemical degradation of  $\text{MoS}_2$ , with the predominant chemical reaction in air being oxidation (refs. 5 to 12). It has also been proposed that moisture in the atmosphere accelerates the oxidation process (ref. 10).

Very few studies have been conducted on how  $\text{MoS}_2$  films lubricate and fail from a microscopic point of view. In one of the few, Salomon, De Gee, and Zaat (refs. 8 and 9) have recorded morphological changes of  $\text{MoS}_2$  films photographically by stroboscopic illumination. They observed that  $\text{MoS}_2$  compacts and sinters on the wear track to a highly reflective film and that oxidation of  $\text{MoS}_2$  leads to embrittlement, blistering, and scaling of the films.

This investigation was conducted to extend those results. The object was to determine (1) how  $\text{MoS}_2$  films lubricate and the role of the transfer film in the lubrication process, and (2) how failure occurs and the roles of oxygen and water in the failure process. Accordingly, friction, wear rate of riders (which slid on the  $\text{MoS}_2$  films), wear of the rubbed  $\text{MoS}_2$  films, and wear lives were determined and compared for tests conducted in atmospheres of moist air (10 000-ppm  $\text{H}_2\text{O}$ ), dry air (<20-ppm  $\text{H}_2\text{O}$ ), and dry argon (<20-ppm  $\text{H}_2\text{O}$ ).

The technique used was to stop the tests at preset sliding intervals and then to determine what had occurred on the sliding surfaces by optical microscopy at magnifications to 1100. A pin-on-disk sliding friction apparatus and 440C HT steel specimens were used; and the test conditions were a temperature of 25<sup>0</sup> C, a sliding speed of 2.6 meters per second (1000 rpm), and a load of 1 kilogram.

## MATERIALS

Technical-grade  $\text{MoS}_2$  powder with an average particle size of 10 micrometers was used in this study. The size ranged from less than 1 micrometer to 75 micrometers;

however, the larger particles appeared to be conglomerations of smaller particles.

The riders and disks were made of 440C HT steel with a Rockwell hardness of C-60. The disks were lapped and polished to a surface finish of  $0.09 \pm 0.02$  micrometer CLA (centerline average). Disks then were roughened (by sanding in random directions with number-150-grit wet sandpaper) to  $0.03 \pm 0.05$  micrometer CLA.

The  $\text{MoS}_2$  was applied to the sanded disk surface by mechanically rubbing it over the surface at constant load (see the section PROCEDURE). The thickness of the films obtained was about 1 to 2 micrometers.

## APPARATUS

A pin-on-disk sliding friction apparatus was used in this study. The apparatus has been described in a previous report (ref. 13). Basically the friction specimens, shown in figure 1, consisted of a flat disk (6.3-cm diameter) in sliding contact with a stationary, hemispherically tipped rider (0.476-cm radius). The rider slid on a 5-centimeter-diameter track on the disk for a linear sliding speed of 2.6 meters per second at a disk rotation of 1000 rpm.

The apparatus used to apply the solid lubricant powder to the disks is shown in figure 2. The disk was attached to the vertical shaft of a small electric motor by means of a cup-shaped holder. Two vertical rods were used to restrain a floating metal plate to which were attached the solid lubricant applicators. In these experiments, the backs of polishing cloths were used as applicators. The rubbing load was applied by placing two 1-kilogram weights on top of the metal plate.

The rubbing apparatus was designed to fit within the bell jar of a vacuum system so that the atmosphere in which the films were applied could be controlled. This was done by evacuating the bell jar to 1000 pascals and then backfilling to atmospheric pressure with the desired atmosphere. Previous results (ref. 14) have shown that films applied in moist air are thicker and denser than films applied under dryer conditions. Therefore the films in these experiments were applied in moist air (10 000-ppm  $\text{H}_2\text{O}$ ).

## PROCEDURE

### Surface Cleaning

The surfaces were cleaned before they were coated with  $\text{MoS}_2$ , as follows:

- (1) Scrub the surface under running tap water with a brush to remove abrasive particles.
- (2) Clean the surface with pure ethyl alcohol.

(3) Rub the surface with a water paste of levigated alumina. Clean until water wets the surface readily.

(4) Rinse the surface under running tap water to remove levigated alumina. Use a brush to facilitate removal.

(5) Rinse the surface in distilled water.

(6) Dry the surface with dry compressed air. (Surfaces not dried quickly tend to oxidize.)

The riders were also cleaned by this procedure; but, since only polished riders were used, step 1 was not necessary.

### Film Application

The procedure for applying the rubbed films was as follows:

(1) Apply a small amount of  $\text{MoS}_2$  powder to the cleaned disk surface and spread it evenly over the surface with the back of a polishing cloth.

(2) Apply about 0.5 gram of  $\text{MoS}_2$  to the contact zone of the applicator (the back of a polishing cloth attached to the floating metal plate) and distribute it evenly.

(3) Assemble the apparatus as shown in figure 2 and apply two 1-kilogram weights for the load.

(4) Evacuate the bell jar to 1000 pascals and then backfill it to atmospheric pressure with an atmosphere of moist air (10 000-ppm  $\text{H}_2\text{O}$ ). Continue to purge the bell jar with moist air until the disk is removed from the apparatus.

(5) Set the disk into rotation by gradually increasing the speed to 15 rpm and rub for 1 hour.

(6) Remove the disk from the apparatus and blow the loose  $\text{MoS}_2$  debris from the surface with dry compressed air.

### Friction and Wear Tests

A rider and disk (with applied  $\text{MoS}_2$  film) were inserted into the apparatus and the test chamber was sealed. Moist air (10 000-ppm  $\text{H}_2\text{O}$ ), dry air (<20-ppm  $\text{H}_2\text{O}$ ), or dry argon (<20-ppm  $\text{H}_2\text{O}$ ) were purged through the chamber for 15 minutes before each test; and this purge was continued throughout the test. The flow rate was 1500 cubic centimeters per minute, and the volume of the chamber was 2000 cubic centimeters. After 15 minutes of purging, the disk was set into rotation at 1000 rpm and a 1-kilogram load was gradually applied. The test temperature was 25° C.

Each test was stopped after 1 kilocycle (1 min) of sliding. After the rider and disk were removed from the friction apparatus, the contact areas were examined by optical

microscopy and photographed. Surface profiles of the disk wear tracks were also taken. The rider and disk were then placed back into the apparatus, and the previous test procedure was repeated. The rider was not removed from the holder, and locating pins in the apparatus insured that it was returned to its original position.

Each test was stopped and the test procedure repeated after sliding times of 1, 5, 15, 30, 60, 100, 200, 400, 700, and 1500 minutes, or when failure occurred. The failure criterion in this study was a friction coefficient of 0.30; thus wear life is defined as the number of kilocycles of sliding to reach a friction coefficient of 0.30. Rider wear was determined by measuring the diameter of the wear scar on the hemispherically tipped rider and then calculating the volume of material worn away.

### Analysis of Sliding Surfaces

Optical microscopy was used to study the lubricating films, the transfer films, and the wear particles in this investigation. The surfaces were viewed at magnifications of 1100. At high magnifications, vertical resolution was very low ( $\sim 1 \mu\text{m}$ ). This aspect was used to measure the heights of various features on the sliding surfaces such as film thickness and wear track depth.

Vertical illumination of the surfaces showed interference fringes in the  $\text{MoS}_2$  films, both on the disk wear track and on the rider wear scar. Interference fringes indicate that the  $\text{MoS}_2$  particles had flowed together to form a continuous film that was very smooth and that was being sheared thinner and thinner. The gradual depletion of the fringes (as the  $\text{MoS}_2$  flowed through the contact area) indicates that the films were thinner than the wavelength of light ( $0.4 \mu\text{m}$ ) in these areas.

## RESULTS AND DISCUSSION

### Friction, Wear, and Wear Life

The friction, wear, and wear life results presented in this paper are typical of the various experimental conditions evaluated. All experiments were conducted at least twice, with good repeatability. The purpose of the experiments was to provide a better understanding of the lubrication and failure mechanisms and how they are affected by atmosphere. Thus the results presented were selected to show trends rather than to define quantitative values.

Figure 3 gives typical friction traces for hemispherically tipped 440C HT steel riders sliding on  $\text{MoS}_2$  rubbed films that were applied to sanded 440C HT steel disks. Testing was done in atmospheres of moist air (10 000-ppm  $\text{H}_2\text{O}$ ), dry air ( $<20$ -ppm  $\text{H}_2\text{O}$ ),

and dry argon (<20-ppm H<sub>2</sub>O). The gaps in the traces represent the intervals when the tests were stopped so that wear measurements could be made. As the figure illustrates, the friction coefficient and wear life of the MoS<sub>2</sub> rubbed films were highly dependent on atmosphere. The lowest friction coefficient was obtained in both dry air and dry argon (0.01 to 0.02). The lowest friction coefficient in the moist air was 0.08. At startup in dry air and dry argon, the friction coefficient always was higher than its resultant average value. This "run-in" phenomenon did not occur in moist air, where the friction coefficient started out higher (0.08) and either remained at this value or increased with sliding. Since there was higher friction and no run-in in moist air, the run-in phenomenon in the dry atmospheres may have been caused by water adsorbed when the tests were stopped and the MoS<sub>2</sub> films were exposed to laboratory air.

Wear was determined by measuring the diameter of the circular scar on the rider and then calculating from this the volume of material worn from the rider. Table I gives rider wear rates (wear volume per unit of sliding distance) for each sliding interval used in this investigation. Like the friction results, rider wear rates are considerably greater in moist air than in dry air or dry argon. In general (in all three atmospheres), the rider wear process consisted of three regimes: The first was a run-in regime in which wear rates were relatively high, the second was an regime of relatively constant low wear rates, and the third was a regime of higher wear rates that indicated the onset of failure.

The wear of the disk surfaces to which the MoS<sub>2</sub> was applied was also studied. Figure 4 gives typical surface profiles of the wear tracks that were taken after various sliding intervals. The vertical magnification of the surface profiles is about 170 times the horizontal magnification; thus a distorted view of the true surface was obtained. The surface profiles show that the sliding surface of a wear track was very smooth, at least until failure occurred. At failure the wear track was somewhat rough because powdery metallic debris and powdery transformed MoS<sub>2</sub> had built up. This is discussed in the following section. From the surface profiles, metallic wear could not be distinguished from film wear. The MoS<sub>2</sub> rubbed films were about 1 to 2 micrometers thick, and the wear tracks were of the same depth. Thus, in general, very little wear occurred to the metallic disks.

### Optical Observations of Sliding Surfaces

A unique technique was used in this investigation to study the lubrication and failure mechanisms of MoS<sub>2</sub> films. Ideally the best technique would be to directly observe what is happening within the sliding contact; however, this is not possible with a metal sliding on a film applied to a metallic surface. Thus the next best thing was attempted, and that was to stop the tests at preset sliding intervals and to examine the sliding surfaces by



optical microscopy at high magnifications. The technique proved very successful in that what was occurring dynamically could be inferred from the static surfaces. The results were very dependent on the atmosphere in which the MoS<sub>2</sub> films were evaluated; thus the results for each atmosphere are presented separately.

### Moist Air

The moist-air atmosphere might be considered a typical condition; that is, an atmosphere of 50-percent-relative-humidity air at 25° C (~10 000-ppm H<sub>2</sub>O). Figures 5 to 7 show the sliding surfaces after 1, 5, and 10 kilocycles of sliding.

After only 1 kilocycle (1 min) of sliding (fig. 5(a)), there was a large buildup of MoS<sub>2</sub> in the entrance region of the scar. The MoS<sub>2</sub> was powdery at the leading edge but became highly compressed toward the contact region. In fact, in the contact region, the MoS<sub>2</sub> particles coalesced and it was impossible to distinguish individual particles. The coalesced MoS<sub>2</sub> film tended to flow plastically across the contact area and then to break up into fine powdery material in the exit region. Coalescing and plastic flow seem to be characteristics that good solid lubricants possess. Sliney (ref. 14) has observed this with an optical microscope by viewing dynamically various solid lubricant powders as they pass through the contact area of a metal ball sliding on a glass disk.

The wear track on the rubbed MoS<sub>2</sub> film is shown in figure 5(b) after 1 kilocycle of sliding. In the center of the wear track, most of the original film had been plowed away and what remained was compacted MoS<sub>2</sub> in the sanded scratches. The MoS<sub>2</sub> tended to flow from the scratches in very thin films across the flat metallic plateaus between the scratches.

After 5 kilocycles of sliding (fig. 6), definite change had taken place on the sliding surfaces; most of the smooth, coalesced material was gone and what remained was black, powdery debris. The high-magnification photomicrographs of figure 6 show areas within the coalesced MoS<sub>2</sub> films that were transforming to a black, powdery material.

After 10 kilocycles of sliding (fig. 7), failure occurred (a friction coefficient of 0.30). No smooth, coalesced MoS<sub>2</sub> films were found on either the rider or the wear track. Instead, a heavy, rippled powdery film was found on both rider and disk sliding surfaces. Significantly, failure was marked by the buildup of a heavy transfer film on both surfaces, and no galling was evident on either surface.

### Dry Air

Experiments like those conducted in moist air were conducted in dry air (<20-ppm H<sub>2</sub>O) so that the effect of water vapor on the lubrication and failure mechanisms of MoS<sub>2</sub>

films could be determined. Figure 8 shows photomicrographs of rider wear and transfer films after 1, 15, 60, and 100 kilocycles of sliding in dry air. Figure 9 shows higher magnification photographs of the transfer films shown in figure 8.

After 1 kilocycle of sliding, transfer to the rider was like that in moist air; that is, the transfer film was fairly heavy. After continued sliding in dry air, the transfer film became considerably thinner (figs. 8(a) and 9(a)). After 15 kilocycles of sliding (figs. 8(b) and 9(b)) the heavy transfer film of  $\text{MoS}_2$  had disappeared and layer-like flow of  $\text{MoS}_2$  through the contact was occurring. After 60 kilocycles of sliding (figs. 8(c) and 9(c)), no layer-like flow was visible in the center of the rider scar. As the  $\text{MoS}_2$  moved into the contact zone (flat area), it was sheared thinner and thinner. Interference fringes are visible in this region, but in the actual contact region the  $\text{MoS}_2$  was sheared too thin for interference fringes to occur and the transfer was milky colored (figs. 8(c) and 9(c)).

At failure (figs. 8(d) and 9(d)), the transfer film resembled that in moist air; that is, it was heavy, rippled, and coarse. This film still possesses flow properties (fig. 9(d)).

Figure 10 shows photomicrographs of  $\text{MoS}_2$  film wear progression in dry air, and figure 11 shows higher magnification photomicrographs of interesting features within those films at the same sliding intervals. The  $\text{MoS}_2$  film on the wear track formed in dry air covered the surface more continuously and had a greater metallic luster than did the wear track films formed in moist air. After 1 kilocycle of sliding (figs. 10(a) and 11(a)), the  $\text{MoS}_2$  films had become black in areas, and as sliding continued the number of these areas increased. Where the film was thicker, the black areas took the form of bubbles (figs. 10(b) and 11(b)) and as sliding continued the number increased (fig. 10(c)). At failure (100 kilocycles of sliding), a powdery material built up on the wear track as in moist air (figs. 10(d) and 11(d)). Thus the transformation of  $\text{MoS}_2$  occurred in dry air as well as in moist air; however, the rate was much slower in dry air.

### Dry Argon

Experiments like those conducted in dry and moist air were conducted in dry argon (<20-ppm  $\text{H}_2\text{O}$ ) so that the effect of oxidation on the lubrication and failure mechanisms of  $\text{MoS}_2$  films could be determined. Figure 12 shows photomicrographs of rider wear scars after 1, 60, 700, and 1860 kilocycles of sliding. Rider transfer characteristics in dry argon were not markedly different than those in dry air. However, the test in dry argon lasted considerably longer.

Figure 13 shows higher-magnification photomicrographs of the rider wear scars for these sliding intervals. As in dry air, the  $\text{MoS}_2$  tended to buildup in the rider entrance and then was sheared thinner and thinner as it passed through the contact region and also

with sliding time. In figure 13(c),  $\text{MoS}_2$  is shown flowing from the exit of the rider scar. In figure 13(d), the buildup of a heavy transfer film at failure is shown.

Little evidence of  $\text{MoS}_2$  transformation in dry argon was found on the rider or in the film wear track. The films were very smooth and had a bright metallic luster. Figures 14 and 15 show photomicrographs of the wear tracks at intervals that correspond to the intervals used for the riders. After 1 kilocycle of sliding (fig. 14(a)), the film on the wear track was smooth and continuous and the metallic substrate was not visible. There were a few bubble-like protrusions at the outer edge of the wear track after 1 kilocycle of sliding (figs. 14(a) and 15(a)). These bubbles could also be found in the center of the wear track at longer sliding intervals (fig. 14(b)). Figure 15(b) shows one of these bubble areas in which the bubbles had cracked and spalled from the surface. These areas of bubbling, cracking, and spalling were localized and most of the track remained smooth and continuous. Since there was no change in color (i. e., the areas remained metallic colored and did not turn black), it is surmised that no transformation of  $\text{MoS}_2$  was occurring.

After continued sliding, the spalled areas tended to be self-healing; nevertheless, after long sliding the films started to thin in the center (figs. 14(c) and 15(c)). After 1500 kilocycles of sliding, the friction started to get "rough." At the sides of the wear track the film still had a metallic luster (fig. 14(d)); however, in the middle of the wear track the film looked disrupted. This disrupted area was a buildup of powdery material (fig. 15(d)).

Sliding was continued from this point until the friction coefficient reached 0.30 (1860 kilocycles of sliding). Both the rider and the wear track surfaces looked much the same as they did after 1500 kilocycles of sliding, except that both surfaces were now almost completely covered with the powdery material. Thus, as in moist and dry air, failure in dry argon was characterized by the buildup of a coarse, powdery film on both rubbing surfaces. In contrast to the results in air, this powdery debris is believed to result from the depletion of  $\text{MoS}_2$  by radial flow from the contact area rather than by depletion of  $\text{MoS}_2$  by chemical transformation.

### Comparison of Results

Increasingly better results were obtained in this investigation in dry air and dry argon than in moist air. The results indicate that water and oxygen are very detrimental to  $\text{MoS}_2$  lubrication. In moist air and dry air, the  $\text{MoS}_2$  film on the sliding surfaces was transformed from a bright, metallic-colored, coalesced film to a dark, black, less continuous film. The rate of transformation depended on sliding time and whether or not the air atmosphere contained water. In dry argon little or no transformation of  $\text{MoS}_2$  was observed by optical microscopy.

Because the transformed areas were very small ( $<1 \times 10^{-8} \text{ m}^2$ ) and the amount of film transformed was also small, no analysis was made to determine whether the  $\text{MoS}_2$  had undergone any chemical change. However, several studies have been conducted on the chemical decomposition of  $\text{MoS}_2$  films under sliding conditions (refs. 6 to 12). It has been shown that the predominant chemical reaction taking place is oxidation of  $\text{MoS}_2$ . It has also been proposed that water in the atmosphere greatly accelerates the oxidation process (ref. 10). Thus the results of this investigation support those conclusions.

In all three atmospheres, failure was characterized by the buildup of a coarse, powdery film on both rubbing surfaces. In air, the transformation of  $\text{MoS}_2$  led to the gradual generation of very fine metallic wear particles that combined with the remaining  $\text{MoS}_2$  or transformed  $\text{MoS}_2$  to produce the powdery films. In dry argon, the gradual depletion of the films by radial flow from the contact also led to the generation of fine metallic wear particles that combined with the remaining  $\text{MoS}_2$  to produce the powdery films. Chemical transformation of  $\text{MoS}_2$  may also have occurred in dry argon, but it was not observable optically.

In dry air and dry argon, the friction coefficients for most of the tests were less than 0.02. In moist air, the lowest friction coefficient was 0.08. Optical observations of the sliding surfaces indicate that friction was higher in moist air because of the rapid transformation of  $\text{MoS}_2$ , which affected the film-forming properties. After 1 kilocycle of sliding, the film was not nearly as continuous in moist air (fig. 5(b)) as in dry air (fig. 10(a)). There was thus more metallic contact and higher friction.

The amount of  $\text{MoS}_2$  transferred to the rider did not affect the friction coefficient. Figures 8 and 12 show varying degrees of  $\text{MoS}_2$  transfer to the rider scar, but figure 3 shows that this did not affect the friction coefficient. Only when the transfer became powdery (transformed  $\text{MoS}_2$  and or powdery metallic debris), was the friction observed to increase (figs. 8(d), 9(d), 12(d), and 13(d)).

Rider wear rates were lowest in dry argon and highest in moist air (table I). This corresponds to the rate of  $\text{MoS}_2$  transformation. Transformed  $\text{MoS}_2$  did not lubricate (or did not lubricate as well as  $\text{MoS}_2$ ), so there was more metallic contact through the film and thus higher wear. The transformed  $\text{MoS}_2$  itself may also have contributed to the higher rider wear.

## SUMMARY OF RESULTS

Friction, wear, and optical microscopy studies of molybdenum disulfide ( $\text{MoS}_2$ ) rubbed films in moist air (10 000-ppm  $\text{H}_2\text{O}$ ), dry air ( $<20$ -ppm  $\text{H}_2\text{O}$ ), and dry argon ( $<20$ -ppm  $\text{H}_2\text{O}$ ) had the following results:

1. The lubricating mechanism consisted of the formation of a thin, coalesced  $\text{MoS}_2$  film on each sliding surface during the initial stages of sliding and then the continual

plastic flow (shear) of this film between the sliding surfaces. The transfer film was formed dynamically: Molybdenum disulfide powder built up in the entrance region of the rider scar, became compacted, and eventually coalesced into a very thin film in the contact region as it flowed toward the exit region.

2. Two failure mechanisms were operating:

a. The first failure mechanism was the transformation of bright, metallic-colored, coalesced films of  $\text{MoS}_2$  to a black, more powdery material. This type of failure occurred in the air atmospheres (moist and dry) but did not occur in dry argon.

b. The second failure mechanism occurred when transformation of  $\text{MoS}_2$  was not observed (i. e., in dry argon). In this case, sliding cracked and spalled the metallic-colored, coalesced films. This, coupled with the fact that the  $\text{MoS}_2$  tended to flow radially outward on the film wear track, resulted in the gradual depletion of the film.

Both failure mechanisms induced the gradual generation of fine metallic wear particles that combined with the remaining  $\text{MoS}_2$  or transformed  $\text{MoS}_2$  to produce coarse, powdery films on both rubbing surfaces.

3. The rate of  $\text{MoS}_2$  transformation was lowest in dry argon and highest in moist air. As the rate of transformation increased the wear life decreased and rider wear rate increased.

Lewis Research Center,  
National Aeronautics and Space Administration,  
Cleveland, Ohio, May 17, 1978,  
505-04.

#### REFERENCES

1. Johnson, R. L.: A Review of the Early Use of Molybdenum Disulfide as a Lubricant. NASA TM X-52343, 1967.
2. Winer, W. O.: Molybdenum Disulfide as a Lubricant: A Review of the Fundamental Knowledge. Wear, vol. 10, 1967, pp. 422-452.
3. Farr, J. P. G.: Molybdenum Disulfide in Lubrication: A Review. Wear, vol. 35, 1975, pp. 1-22.
4. Holinski, R.; and Gansheimer, J.: A Study of the Lubricating Mechanism of Molybdenum Disulfide. Wear, vol. 19, 1972, pp. 329-342.

5. Peterson, M. B.; and Johnson, R. L.: Friction and Wear Investigation of Molybdenum Disulfide. I - Effect of Moisture. NACA TN 3055, 1953.
6. Ross, S.; and Sussman, A.: Surface Oxidation of Molybdenum Disulfide. J. Phys. Chem., vol. 59, 1955, pp. 889-892.
7. Haltner, A. J.; and Oliver, C. S.: Effect of Water Vapor on the Friction of Molybdenum Disulfide. Ind. Eng. Chem. Fundam., vol. 5, 1966, pp. 348-355.
8. Salomon, G.; De Gee, A. W. J.; and Zaat, J. H.: Mechano-Chemical Factors in MoS<sub>2</sub> Film Lubrication. Wear, vol. 7, 1964, pp. 87-101.
9. De Gee, A. W. J.; Salomon, G.; and Zaat, J. H.: On the Mechanisms of MoS<sub>2</sub> Film Failure in Sliding Friction. ASLE Trans., vol. 8, Apr. 1965, pp. 156-162.
10. Pritchard, C.; and Midgley, J. W.: The Effect of Humidity on the Friction and Life of Unbonded Molybdenum Disulfide Films. Wear, vol. 13, 1969, pp. 39-50.
11. Pardee, R. P.: The Effect of Humidity on Low-Load Frictional Properties of a Bonded Solid Film Lubricant. ASLE Trans., vol. 15, no. 2, 1972, pp. 130-142.
12. Gansheimer, J.: A Review on Chemical Reactions of Solid Lubricants during Friction. ASLE Trans., vol. 15, no. 4., 1972, pp. 244-251.
13. Fusaro, R. L.; and Sliney, H. E.: Graphite Fluoride as a Solid Lubricant in a Polyimide Binder. NASA TN D-6714, 1972.
14. Johnston, R. R. M.; and Moore, A. J. W.: The Burnishing of Molybdenum Disulfide onto Metal Surfaces. Wear, vol. 7, 1964, pp. 498-512.
15. Sliney, H. E.: Dynamics of Solid Lubrication as Observed by Optical Microscopy. NASA TM X-71880, 1976.

TABLE I. - EFFECT OF ATMOSPHERE ON WEAR RATE OF RIDERS  
 SLIDING ON RUBBED MOLYBDENUM DISULFIDE (MoS<sub>2</sub>) FILMS  
 APPLIED TO SANDED 440C HT STEEL DISKS

[Experimental conditions: load, 1 kg; sliding speed, 2.6 m/sec (1000 rpm),  
 temperature, 25°C, surface finish, 0.30±0.15 μm CLA.]

Sliding interval, kilocycles	Rider wear rate, m <sup>3</sup> /min		
	In moist air (10 000-ppm H <sub>2</sub> O)	In dry air (<20-ppm H <sub>2</sub> O)	In dry argon (<20-ppm H <sub>2</sub> O)
0 - 1	a. 2.0×10 <sup>-15</sup>	a. 0.19×10 <sup>-15</sup>	a. 0.17×10 <sup>-15</sup>
1 - 5	b. 55×10 <sup>-15</sup>	b. 045×10 <sup>-15</sup>	a. 041×10 <sup>-15</sup>
5 - 10	c. 2.4×10 <sup>-15</sup>	-----	-----
5 - 15	(d)	b. 056×10 <sup>-15</sup>	b. 012×10 <sup>-15</sup>
15 - 60	-----	b. 077×10 <sup>-15</sup>	↓
60 - 100	-----	c. 16×10 <sup>-15</sup>	
100 - 200	-----	(d)	
200 - 400	-----	-----	
400 - 700	-----	-----	
700 - 1500	-----	-----	b. 011×10 <sup>-15</sup>
1500 - 1860	-----	-----	c. 018×10 <sup>-15</sup>
			(d)

- <sup>a</sup>Run-in regime.
- <sup>b</sup>Low-wear regime.
- <sup>c</sup>Onset-of-failure regime.
- <sup>d</sup>Failure occurred at end of sliding interval.

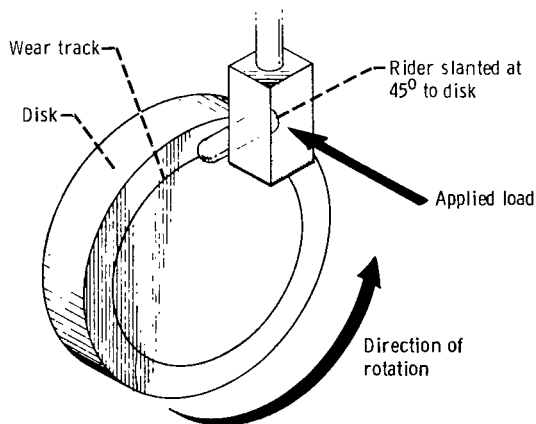

Figure 1. - Schematic diagram of friction specimens.

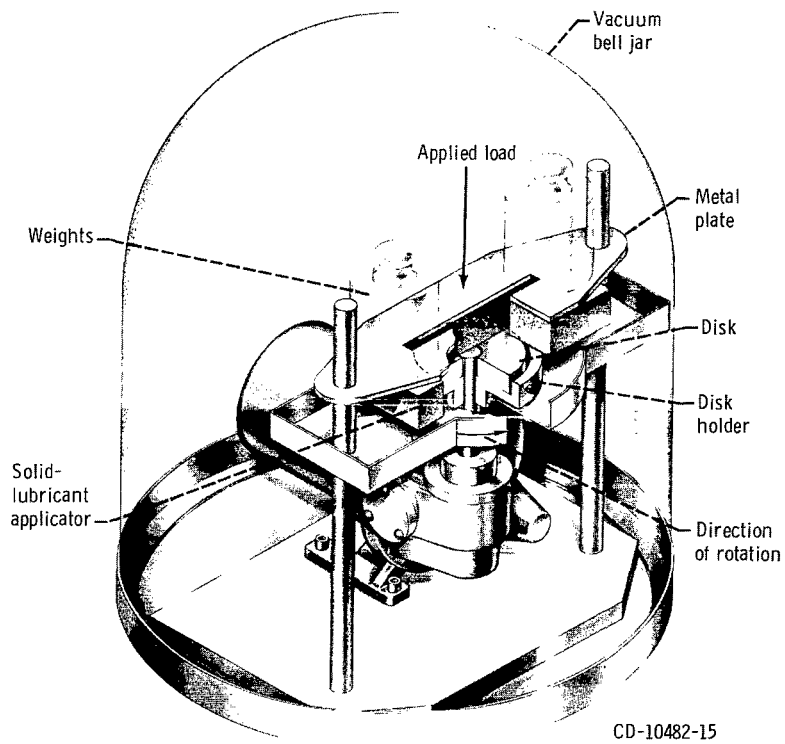

Figure 2. - Apparatus used for applying molybdenum disulfide films.

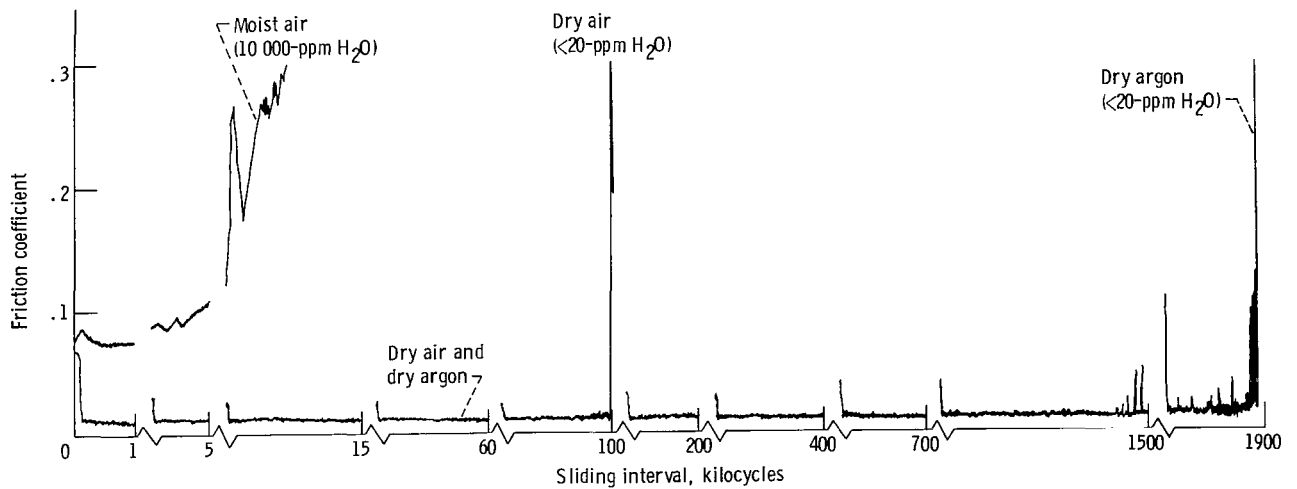

Figure 3. - Friction coefficient as a function of sliding interval for rubbed  $\text{MoS}_2$  films applied to sanded 440C HT steel disks and evaluated in three atmospheres. Rider material, 440C HT steel; sliding speed, 2.6 meters per second (1000 rpm); load, 1 kilogram; temperature,  $25^\circ\text{C}$ .



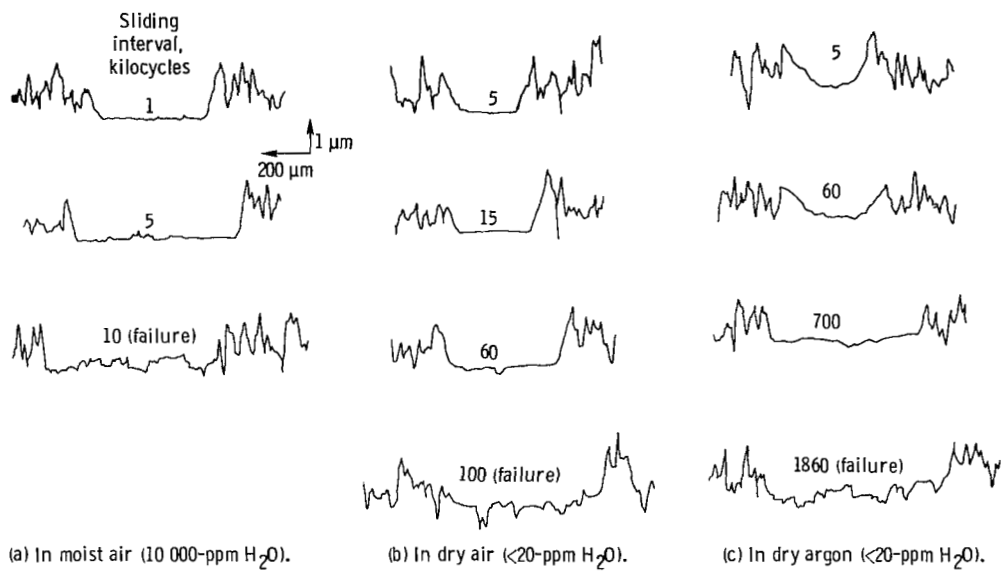
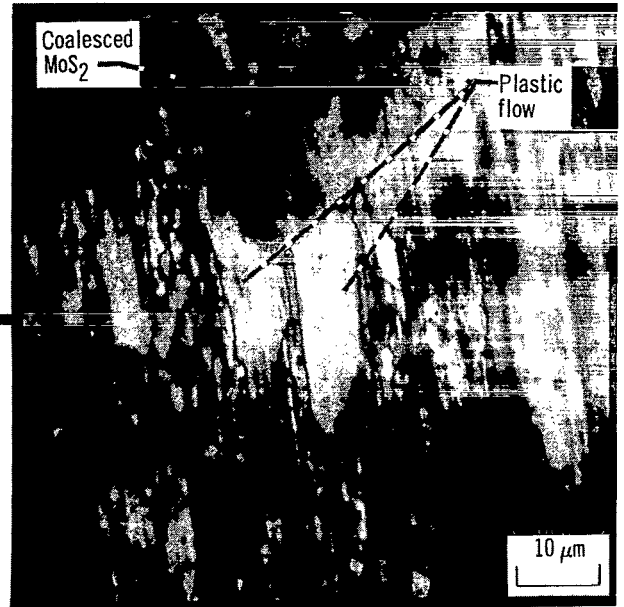
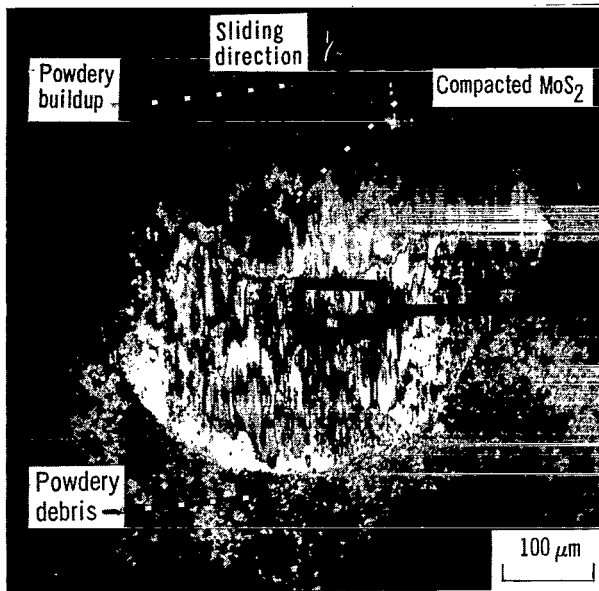
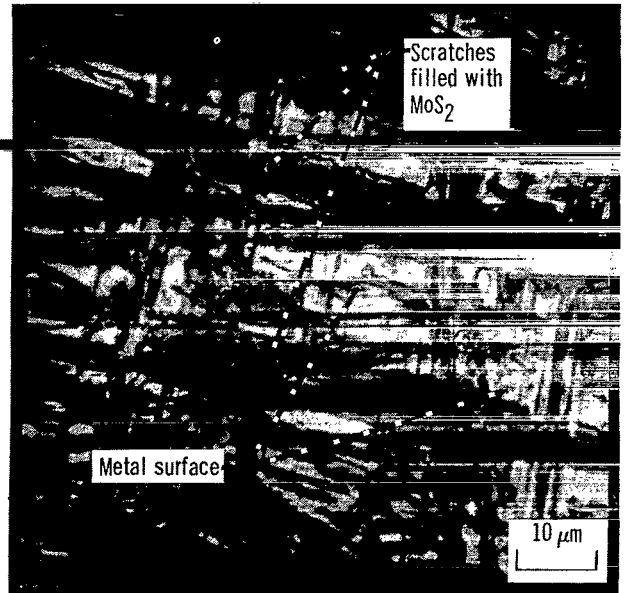
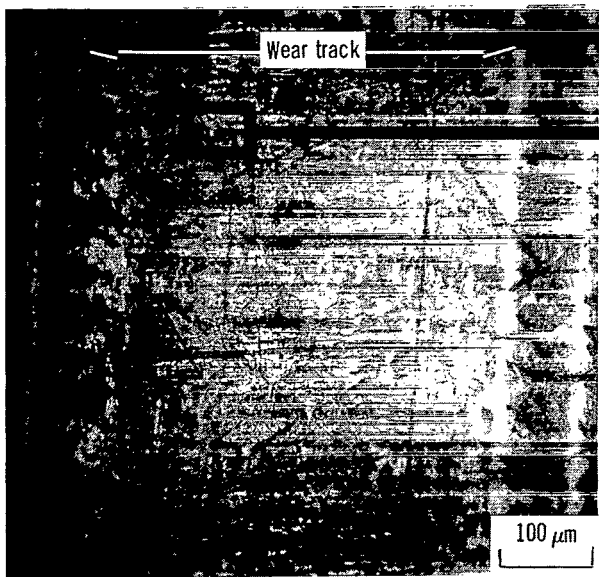

Figure 4. - Surface profiles of wear tracks on rubbed MoS<sub>2</sub> films applied to sanded 440C HT steel disks and evaluated in three atmospheres.



(a) Rider wear scar.



(b) MoS<sub>2</sub> film wear track.

Figure 5. - Photomicrographs of rider wear scar and MoS<sub>2</sub> film wear track after 1 kilocycle of sliding (run-in) in moist air (10 000-ppm H<sub>2</sub>O) at 25° C.

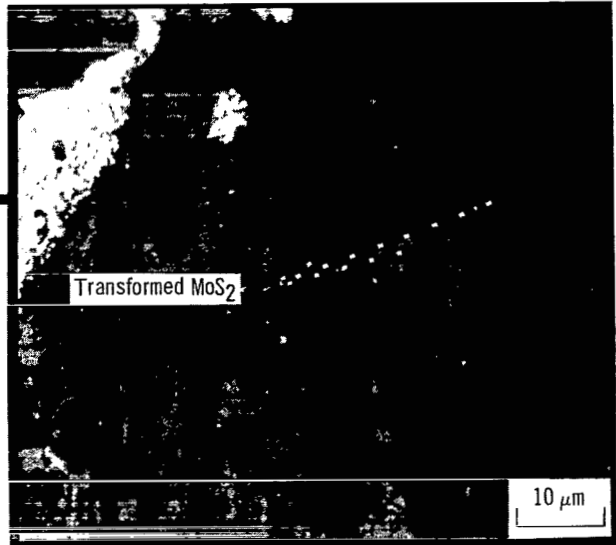
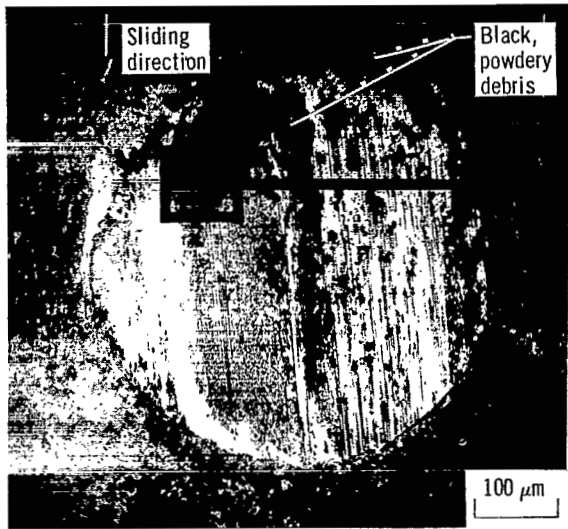

(a) Rider wear scar.

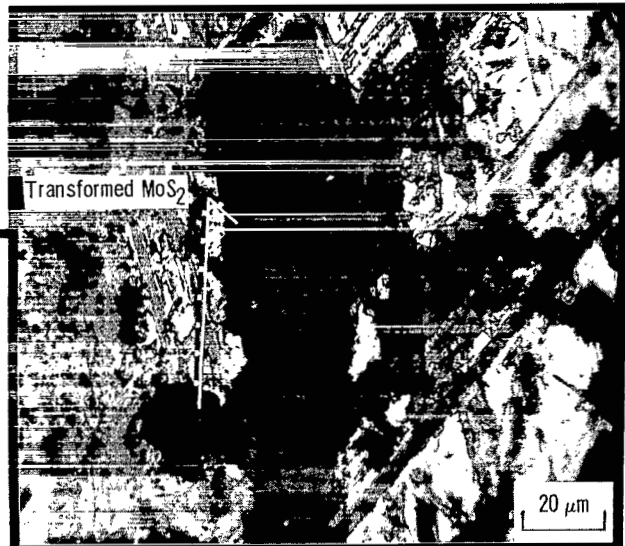
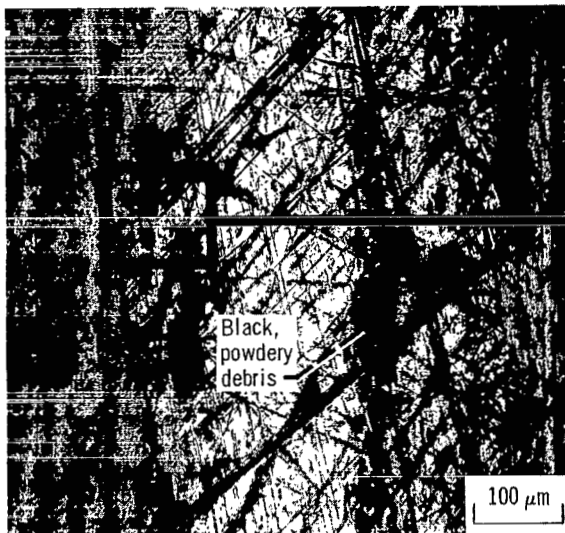

(b) MoS<sub>2</sub> film wear track.

Figure 6. - Photomicrographs of rider wear scar and MoS<sub>2</sub> film wear track after 5 kilocycles of sliding in moist air (10 000-ppm H<sub>2</sub>O) at 25° C.

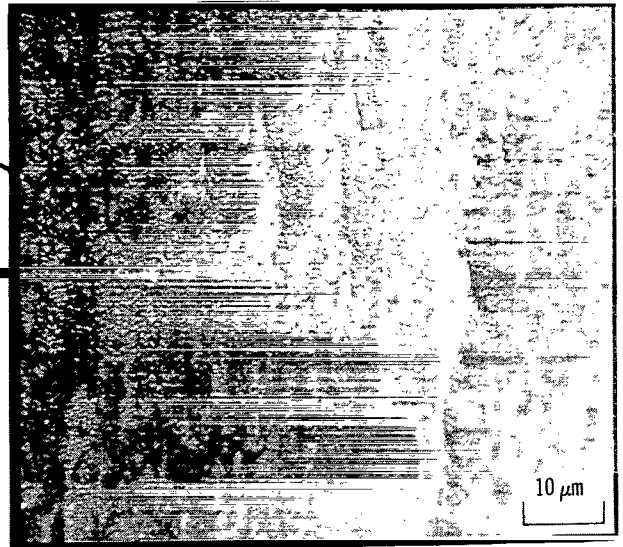
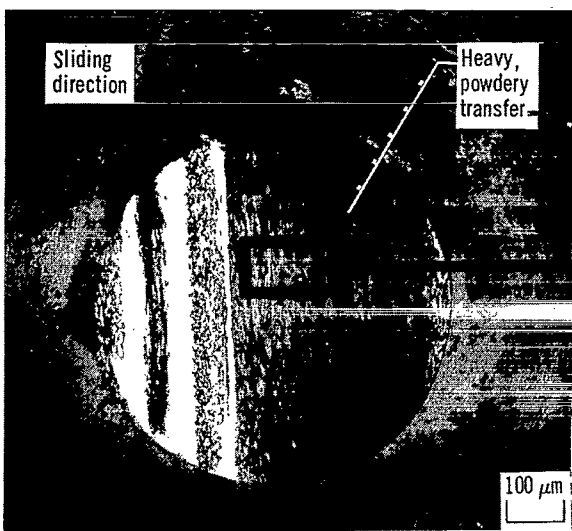

(a) Rider wear scar.

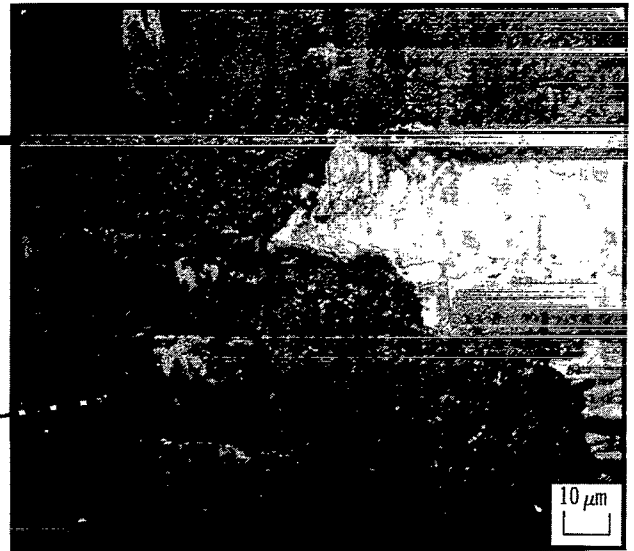
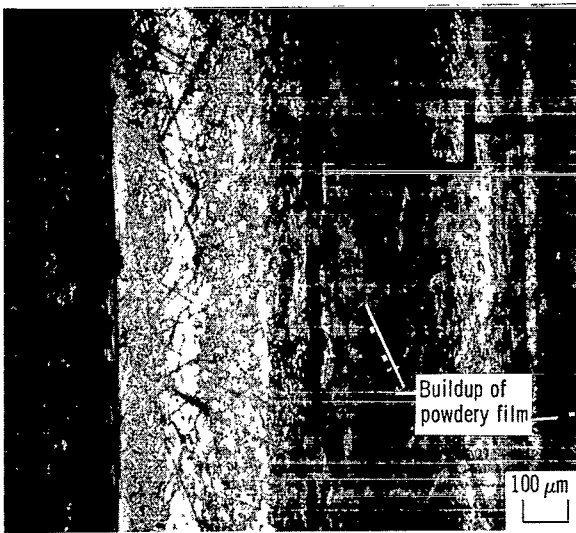

(b) MoS<sub>2</sub> film wear track.

Figure 7. - Photomicrographs of rider wear scar and MoS<sub>2</sub> film wear track after tailure (10 kilocycles of sliding) in moist air (10 000-ppm H<sub>2</sub>O) at 25°C.

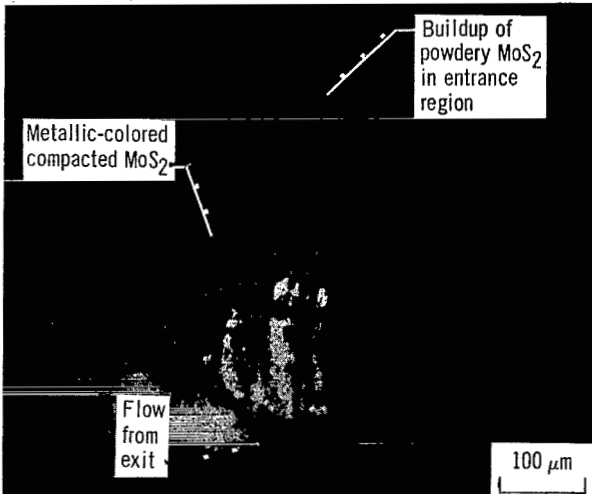

(a) Sliding interval, 1 kilocycle (run-in).



(b) Sliding interval, 15 kilocycles.

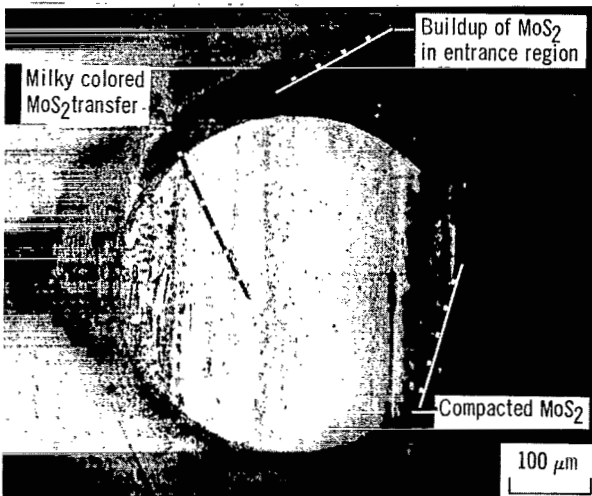

(c) Sliding interval, 60 kilocycles.

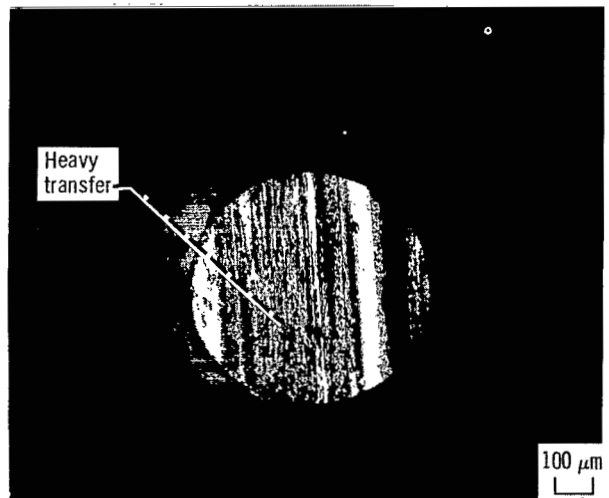

(d) Sliding interval, 100 kilocycles (failure).

Figure 8. - Photomicrographs of rider wear progression and film transfer formation in dry air (<20-ppm H<sub>2</sub>O).

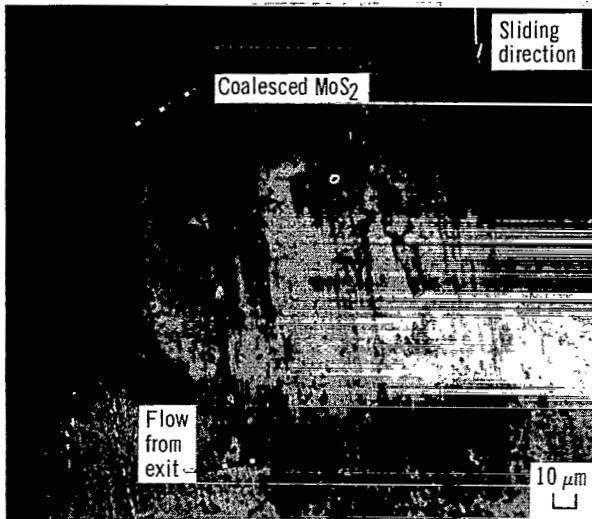

(a) Sliding interval, 1 kilocycle (run-in); rider entrance region.

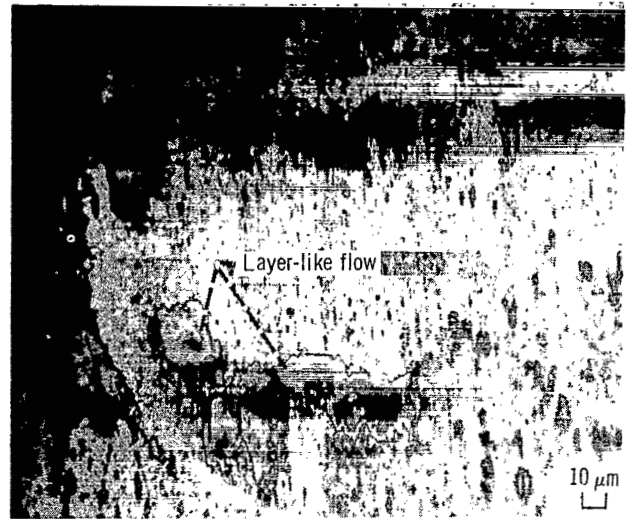

(b) Sliding interval, 15 kilocycles; rider central area.

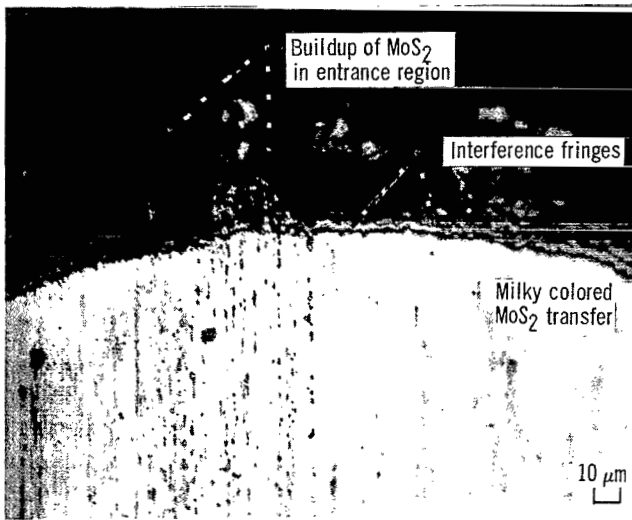

(c) Sliding interval, 60 kilocycles; rider entrance region.

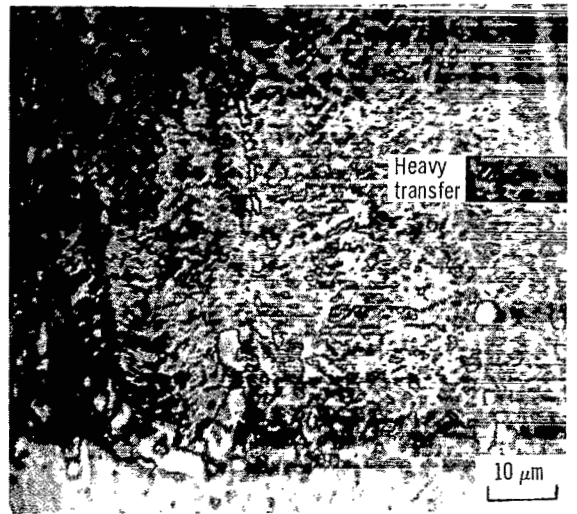

(d) Sliding interval, 100 kilocycles (failure); rider exit region.

Figure 9. - Higher magnification photomicrographs of rider transfer films shown in figure 8.

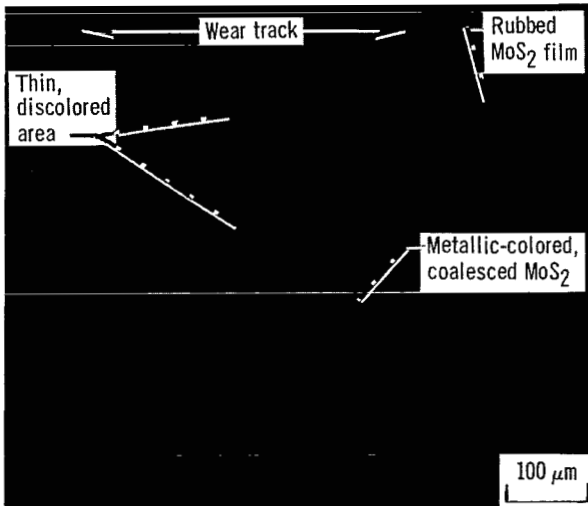

(a) Sliding interval, 1 kilocycle (run-in).

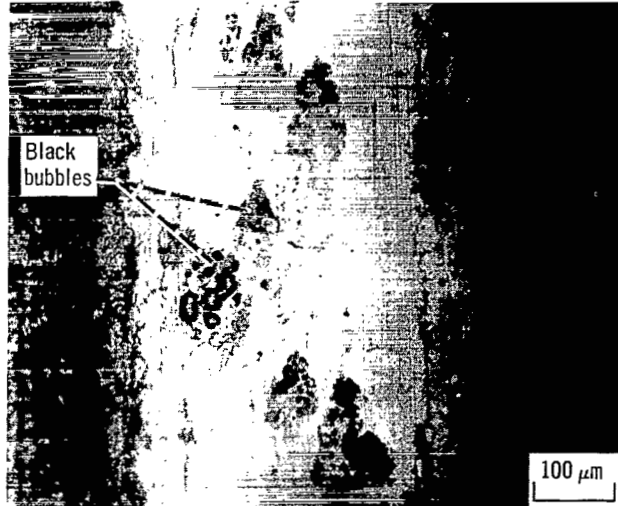

(b) Sliding interval, 15 kilocycles.

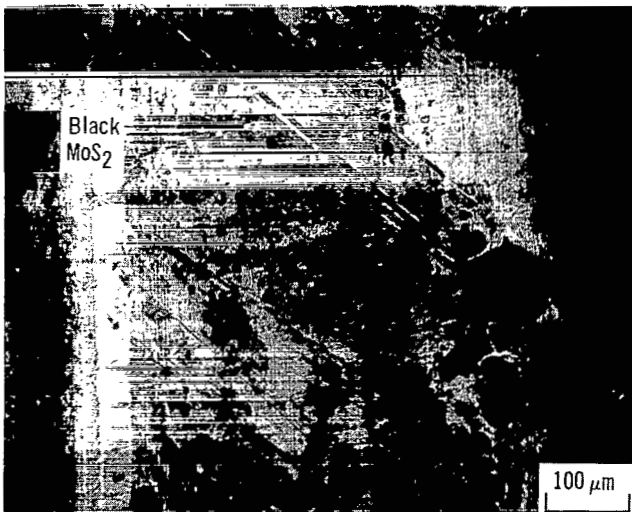

(c) Sliding interval, 60 kilocycles.

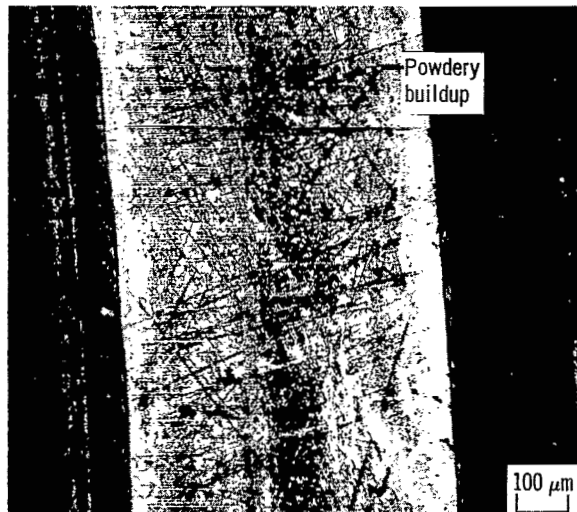

(d) Sliding interval, 100 kilocycles (failure).

Figure 10. - Photomicrographs of MoS<sub>2</sub> film wear progression in dry air (<20-ppm H<sub>2</sub>O).

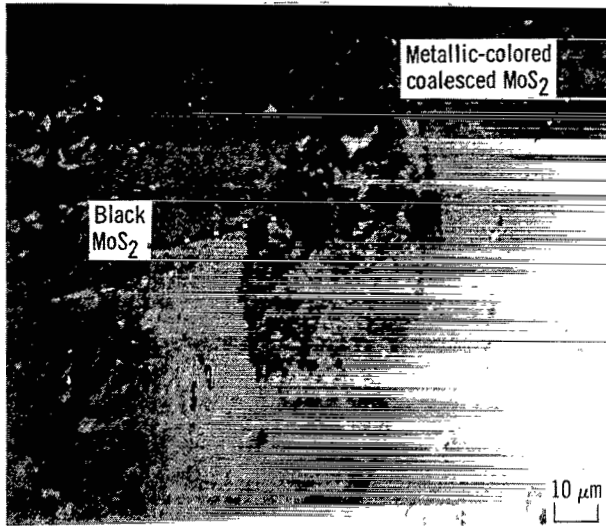

(a) Sliding interval, 1 kilocycle (run-in).

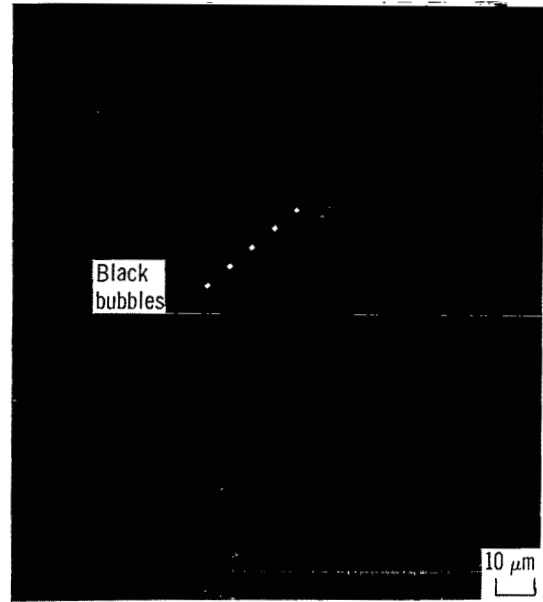

(b) Sliding interval, 15 kilocycles.

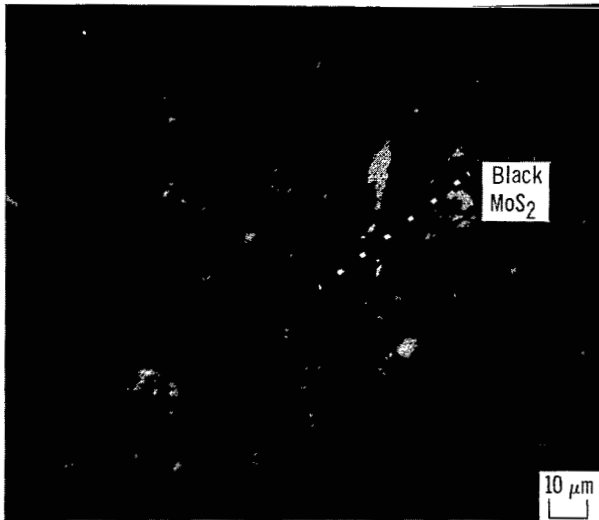

(c) Sliding interval, 60 kilocycles.



(d) Sliding interval, 100 kilocycles (failure).

Figure 11. - Higher magnification photomicrographs of MoS<sub>2</sub> film wear tracks shown in figure 10.



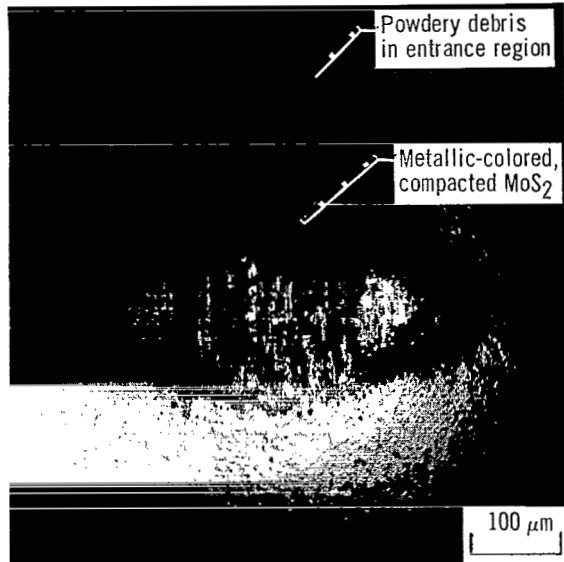

(a) Sliding interval, 1 kilocycle (run-in).

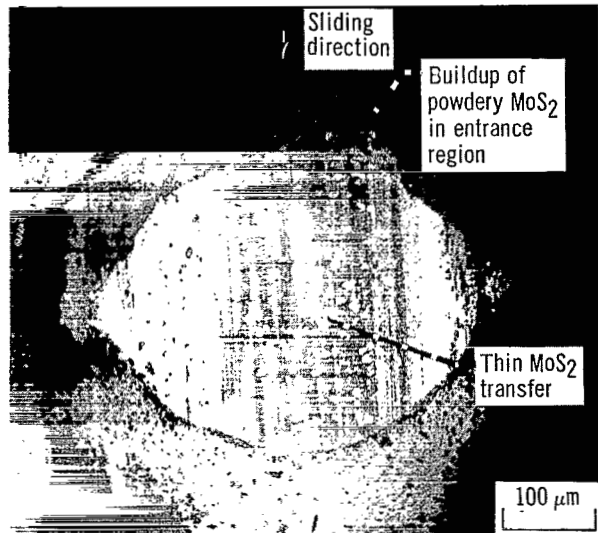

(b) Sliding interval, 60 kilocycles.

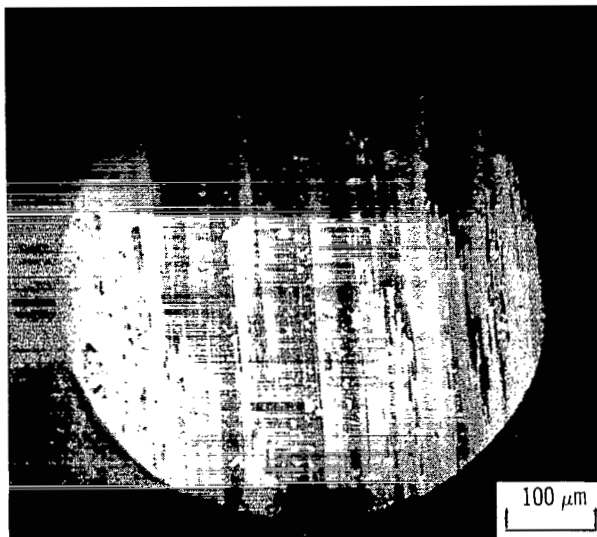

(c) Sliding interval, 700 kilocycles.

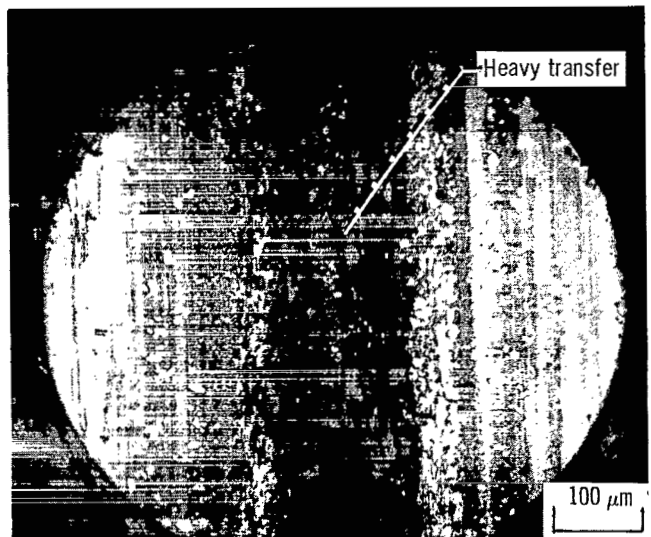

(d) Sliding interval, 1860 kilocycles (failure).

Figure 12. - Photomicrographs of rider wear progression and film transfer formation in dry argon (<20-ppm H<sub>2</sub>O).

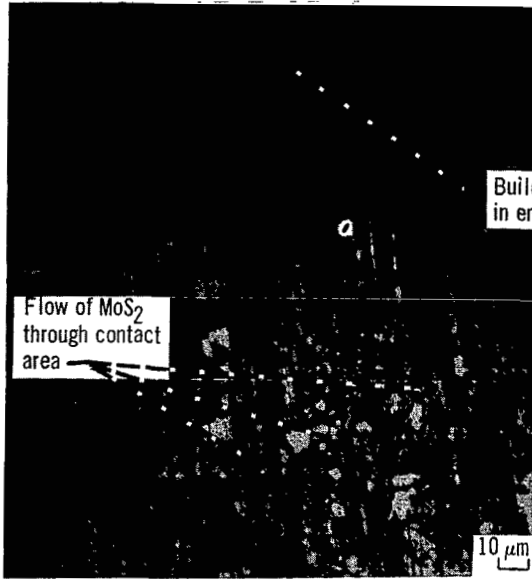

(a) Sliding interval, 1 kilocycle; rider entrance region.

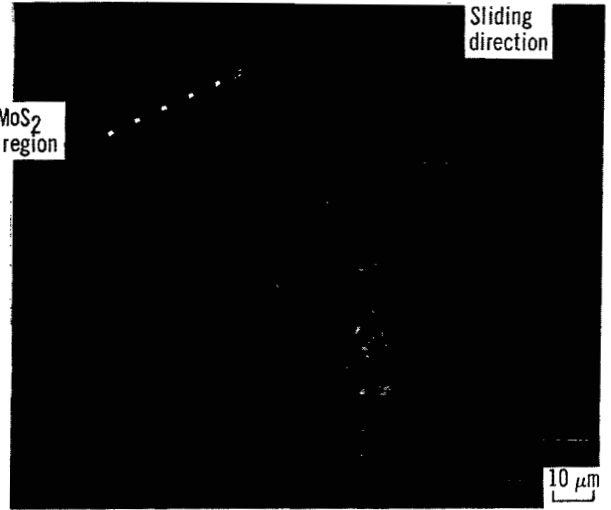

(b) Sliding interval, 60 kilocycles; rider entrance region.

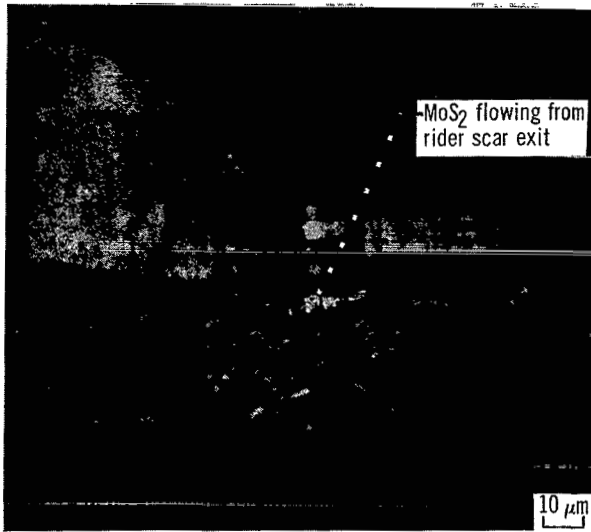

(c) Sliding interval, 700 kilocycles; rider exit region.

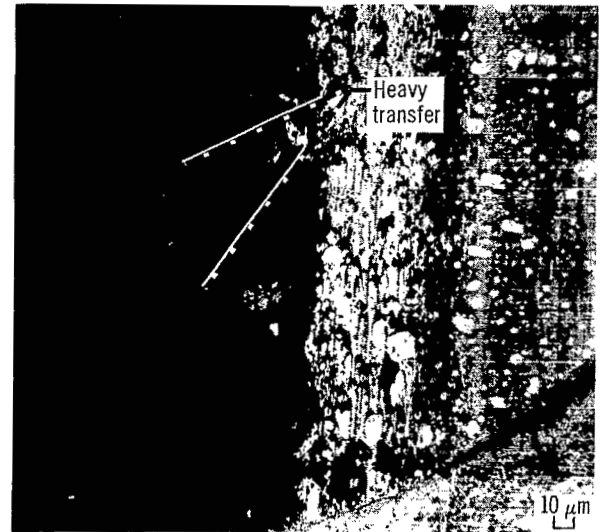

(d) Sliding interval, 1860 kilocycles (failure); rider exit region.

Figure 13. - Higher magnification photomicrographs of rider transfer films shown in figure 12.

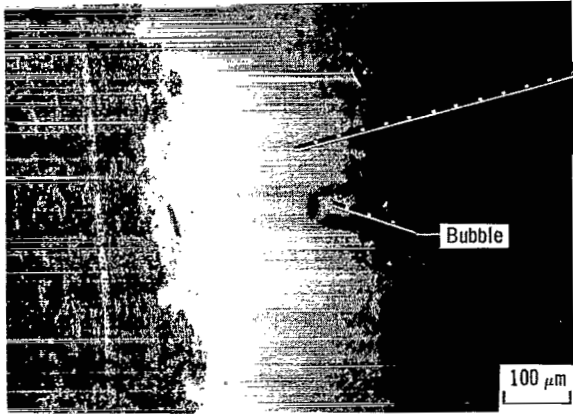

(a) Sliding interval, 1 kilocycle (run-in)

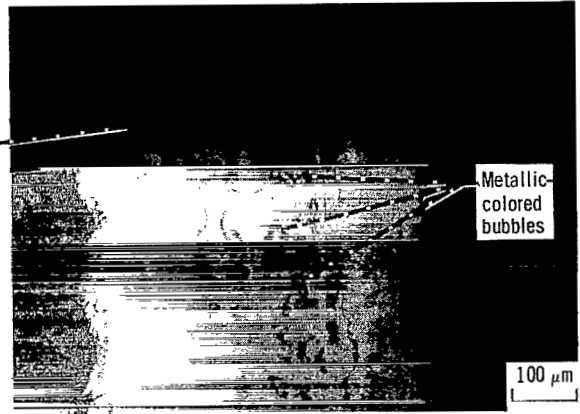

(b) Sliding interval, 60 kilocycles.

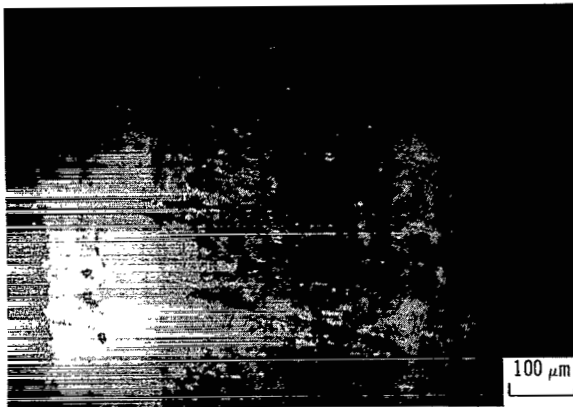

(c) Sliding interval, 700 kilocycles.

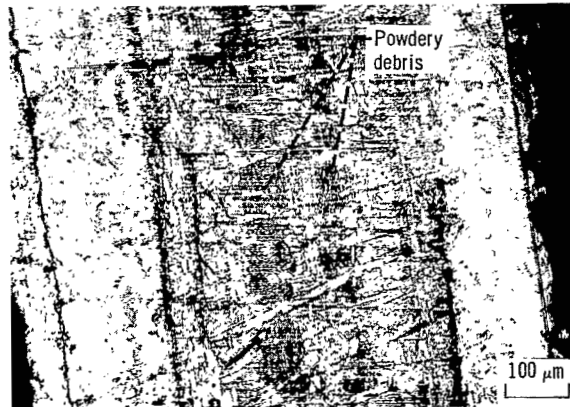

(d) Sliding interval, 1860 kilocycles (failure).

Figure 14. - Photomicrographs of MoS<sub>2</sub> film wear progression in dry argon (<20-ppm H<sub>2</sub>O).

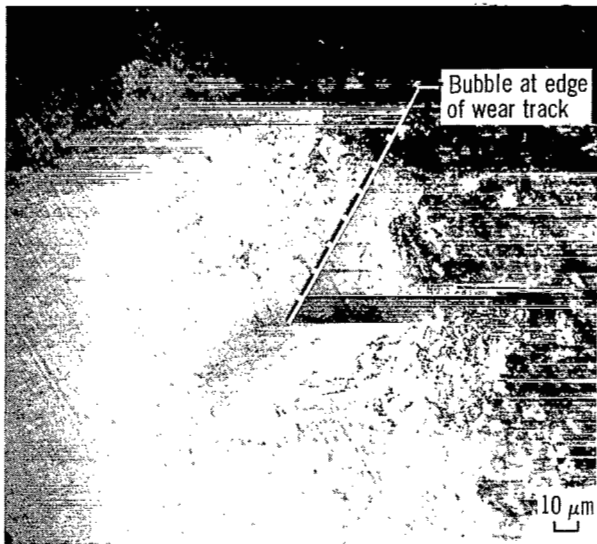

(a) Sliding interval, 1 kilocycle; edge of film wear track.

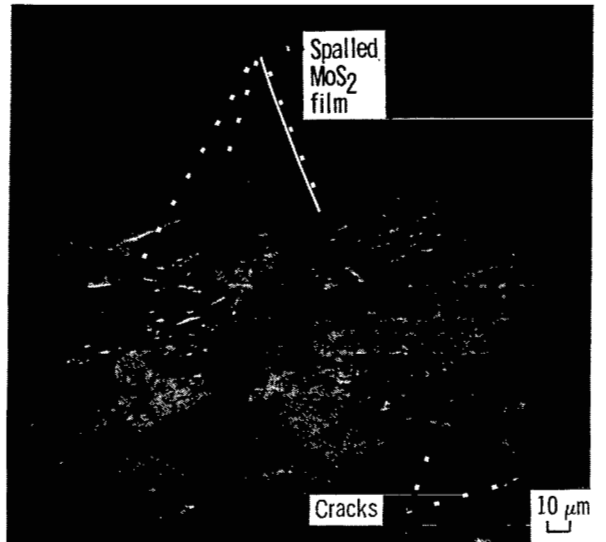

(b) Sliding interval, 60 kilocycles; middle of film wear track.

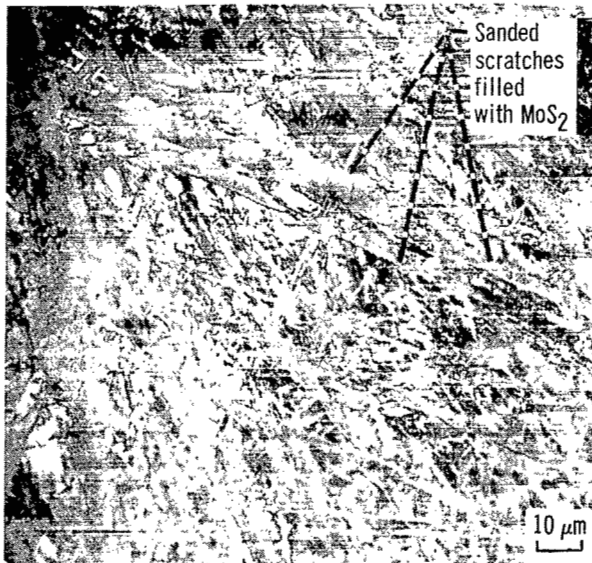

(c) Sliding interval, 700 kilocycles; middle of film wear track.

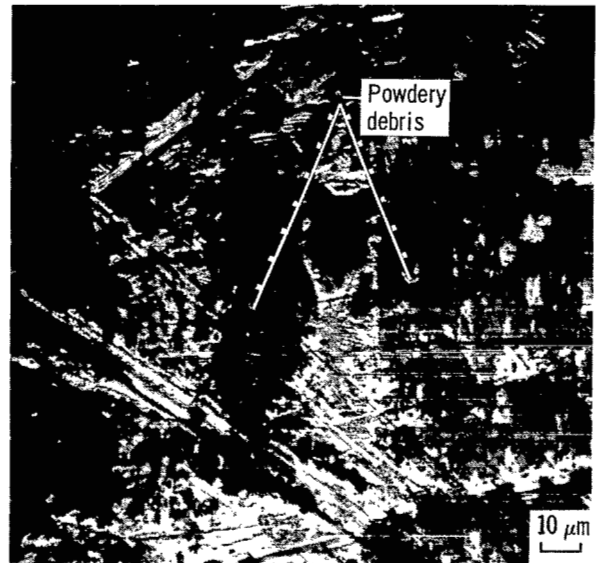

(d) Sliding interval, 1860 kilocycles (failure); middle of film wear track.

Figure 15. - Higher magnification photomicrographs of MoS<sub>2</sub> film wear tracks shown in figure 14.

1. Report No. <b>NASA TP-1343</b>		2. Government Accession No.		3. Recipient's Catalog No.	
4. Title and Subtitle <b>LUBRICATION AND FAILURE MECHANISMS OF MOLYBDENUM DISULFIDE FILMS I - EFFECT OF ATMOSPHERE</b>				5. Report Date <b>December 1978</b>	
7. Author(s) <b>Robert L. Fusaro</b>				6. Performing Organization Code	
9. Performing Organization Name and Address <b>National Aeronautics and Space Administration Lewis Research Center Cleveland, Ohio 44135</b>				8. Performing Organization Report No. <b>E-9600</b>	
12. Sponsoring Agency Name and Address <b>National Aeronautics and Space Administration Washington, D. C. 20546</b>				10. Work Unit No. <b>505-04</b>	
15. Supplementary Notes				11. Contract or Grant No.	
16. Abstract <p>Friction, wear, and wear lives of rubbed molybdenum disulfide (<math>\text{MoS}_2</math>) films applied to sanded 440C HT steel surfaces were evaluated in moist air, dry air, and dry argon. Optical microscope observations were made as a function of sliding distance to determine the effect of moisture and oxygen on the lubricating and failure mechanisms of <math>\text{MoS}_2</math> films. In general, the lubrication process consisted of the formation of a thin, metallic-colored, coalesced film of <math>\text{MoS}_2</math> that flowed between the surfaces in relative motion. In air, failure was due to the transformation of the metallic-colored, coalesced films to a black, powdery material. Water in the air appeared to accelerate the transformation rate. In argon, no transformation of <math>\text{MoS}_2</math> was observed with the microscope, but cracking and spalling of the coalesced film occurred and resulted in the gradual depletion of the film.</p>				13. Type of Report and Period Covered <b>Technical Paper</b>	
17. Key Words (Suggested by Author(s)) <b>Molybdenum disulfide; Lubrication mechanisms; Solid lubricants; Atmosphere effects on solid lubricants; Friction and wear; Transfer film</b>				14. Sponsoring Agency Code	
19. Security Classif. (of this report) <b>Unclassified</b>		20. Security Classif. (of this page) <b>Unclassified</b>		21. No. of Pages <b>27</b>	
18. Distribution Statement <b>Unclassified - unlimited STAR Category 27</b>				22. Price* <b>A03</b>	

National Aeronautics and  
Space Administration

THIRD-CLASS BULK RATE

Postage and Fees Paid  
National Aeronautics and  
Space Administration  
NASA-451



Washington, D.C.  
20546

Official Business  
Penalty for Private Use, \$300

3 1 1U,C, 112778 S00903DS  
DEPT OF THE AIR FORCE  
AF WEAPONS LABORATORY  
ATTN: TECHNICAL LIBRARY (SUL)  
KIRTLAND AFB NM 87117

**NASA**

POSTMASTER: If Undeliverable (Section 158  
Postal Manual) Do Not Return

S