

NASA

National
Aeronautics and
Space
Administration
NASA CP-2057



PROCEEDINGS: SECOND ANNUAL WORKSHOP ON METEOROLOGICAL AND ENVIRONMENTAL INPUTS TO AVIATION SYSTEMS

71

MARCH 28-30, 1978

UNIVERSITY OF TENNESSEE SPACE INSTITUTE

EDITORS: WALTER FROST
DENNIS W. CAMP

(NASA-CP-2057) PROCEEDINGS OF THE 2ND
ANNUAL WORKSHOP ON METEOROLOGICAL AND
ENVIRONMENTAL INPUTS TO AVIATION SYSTEMS
(Tennessee Univ. Space Inst., Tullahoma.)
259 p HC A12/MP A01

N79-17413
THRU
N79-17432
Unclas
14051

CSCI 04B G3/47

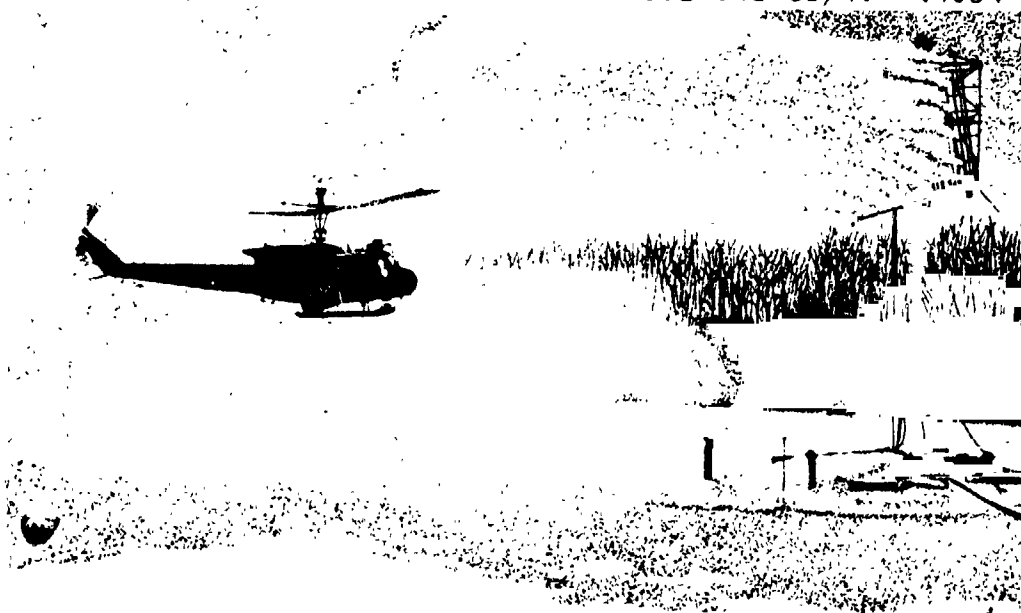

FAA-RD-78-99

TECHNICAL EDITOR: DON E. DURHAM



METRIC CONVERSION FACTORS

Approximate Conversions to Metric Measures

Symbol	When You Know	Multiply by	To Find	Symbol
LENGTH				
in	inches	2.5	centimeters	cm
ft	feet	30	centimeters	cm
yd	yards	0.9	meters	m
mi	miles	1.6	kilometers	km
AREA				
sq in	square inches	6.5	square centimeters	cm ²
sq ft	square feet	0.09	square meters	m ²
sq yd	square yards	0.8	square meters	m ²
sq mi	square miles	2.6	square kilometers	km ²
acres	acres	0.4	hectares	ha
MASS (weight)				
oz	ounces	28	grams	g
lb	pounds	0.45	kilograms	kg
	short tons (2000 lb)	0.9	tonnes	t
VOLUME				
teaspoon	teaspoons	5	milliliters	ml
tablespoon	tablespoons	15	milliliters	ml
fl oz	fluid ounces	30	milliliters	ml
c	cups	0.24	liters	l
pt	pints	0.47	liters	l
qt	quarts	0.95	liters	l
gal	gallons	3.8	liters	l
cu ft	cubic feet	0.03	cubic meters	m ³
cu yd	cubic yards	0.76	cubic meters	m ³
TEMPERATURE (exact)				
°F	Fahrenheit temperature	5/9 (after subtracting 32)	Celsius temperature	°C

Approximate Conversions from Metric Measures

Symbol	When You Know	Multiply by	To Find	Symbol
LENGTH				
mm	millimeters	0.04	inches	in
cm	centimeters	0.4	inches	in
m	meters	3.3	feet	ft
mi	kilometers	1.1	yards	yd
		0.6	miles	mi
AREA				
cm ²	square centimeters	0.16	square inches	in ²
m ²	square meters	1.2	square yards	yd ²
km ²	square kilometers	0.4	square miles	mi ²
ha	hectares (10,000 m ²)	2.5	acres	acres
MASS (weight)				
g	grams	0.035	ounces	oz
kg	kilograms	2.2	pounds	lb
t	tonnes (1000 kg)	1.1	short tons	
VOLUME				
ml	milliliters	0.03	fluid ounces	fl oz
l	liters	2.1	pints	pt
l	liters	1.06	quarts	qt
l	liters	0.26	gallons	gal
m ³	cubic meters	35	cu ft	ft ³
m ³	cubic meters	1.3	cu yd	yd ³
TEMPERATURE (exact)				
°C	Celsius temperature	9/5 (then add 32)	Fahrenheit temperature	°F

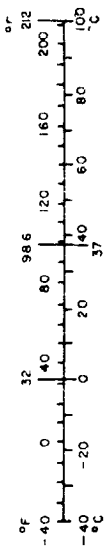
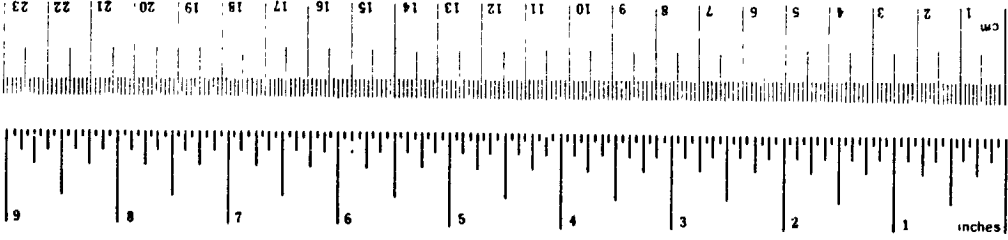

* In S 2.54 (exactly). For other exact conversions and more detail and tables, see NBS Mon. Publ. 290, Units, Weights and Measures, Price \$2.25, SD Catalog No. 613-10-290.

Proceedings of
The Second Annual Workshop
on
Meteorological and Environmental
Inputs to Aviation Systems
March 28-30, 1978

ORGANIZATION COMMITTEE AND SPONSORING AGENCIES

Dennis W. Camp
Aerospace Engineer
Atmospheric Science Division
NASA/Marshall Space Flight Center
Huntsville, Alabama 35812

John W. Connolly
Special Assistant for Aviation Affairs
United States Dept. of Commerce
National Oceanic & Atmospheric Administration
Rockville, Maryland 20852

Walter Frost
Director of Atmospheric Science Division
The University of Tennessee Space Institute
Tullahoma, Tennessee 37388

John E. Enders
Chief, Aviation Safety Technology Branch
NASA Headquarters
Washington, D.C. 20591

Joseph F. Sower
Chief, Aviation Weather Branch, SEDS
FAA
Second & V. Streets NW
Transport Building
Washington, D.C. 20591

Harry L. Burton
Chief, ATS Weather Staff
FAA/AAT-40
800 Independence Ave. NW
Washington, D.C. 20591

Technical Editor

Don E. Durham
The University of Tennessee Space Institute
Tullahoma, Tennessee 37388

TABLE OF CONTENTS

	<u>Page</u>
I. EXECUTIVE SUMMARY	1
II. INTRODUCTION AND WELCOME	15
Opening Remarks John H. Enders	16
Description of Workshop Walter Frost and Dennis W. Camp	17
Welcome Remarks Charles A. Lundquist	26
Welcome Remarks Charles H. Weaver	27
III. BANQUET PRESENTATION	28
Aviation Meteorology--Today and the Future Brigadier General Berry W. Rowe Commander, Air Weather Service, USAF	29
IV. TOPIC AREA PRESENTATIONS	36
Severe Storms John W. Connolly	37
Atmospheric Disturbance Modeling Requirements for Flying Qualities Applications David J. Moorehouse	55
Aircraft Icing Porter J. Perkins	85
Visibility in Aviation Charles A. Douglas	100
Lightning Hazards to Aircraft Philip B. Corn	127
V. SHORT PRESENTATIONS	138
Helicopter Icing Research Richard I. Adams	139
The Prediction of Lightning-Induced Voltages on Metallic and Composite Aircraft John A. Birken	153

	<u>Page</u>
VI. COMMITTEE REPORTS	178
Summary Report of the Severe Storms Committee Jean T. Lee	179
Summary Report of the Turbulence Committee Charles E. Elderkin	185
Summary Report of the Icing Committee Richard I. Adams	192
Summary Report of the Visibility Committee Robert L. Gardner	200
Summary Report of the Lightning and Static Electricity Committee J.A. Plumer	203
Summary Report of the Aircraft Operations Committee Robert T. Warner	215
Summary Report of the Human Factors Committee George E. Cooper	219
Summary Report of the Aircraft Design Committee John T. Rogers	229
Summary Report of the Weather Services Committee Loren J. Spencer	234
Summary Report of the Data Acquisition and Utilization Committee Mikhail A. Alaka	238
APPENDIX	
A List of Acronyms	244
B. Roster of Workshop Participants	248

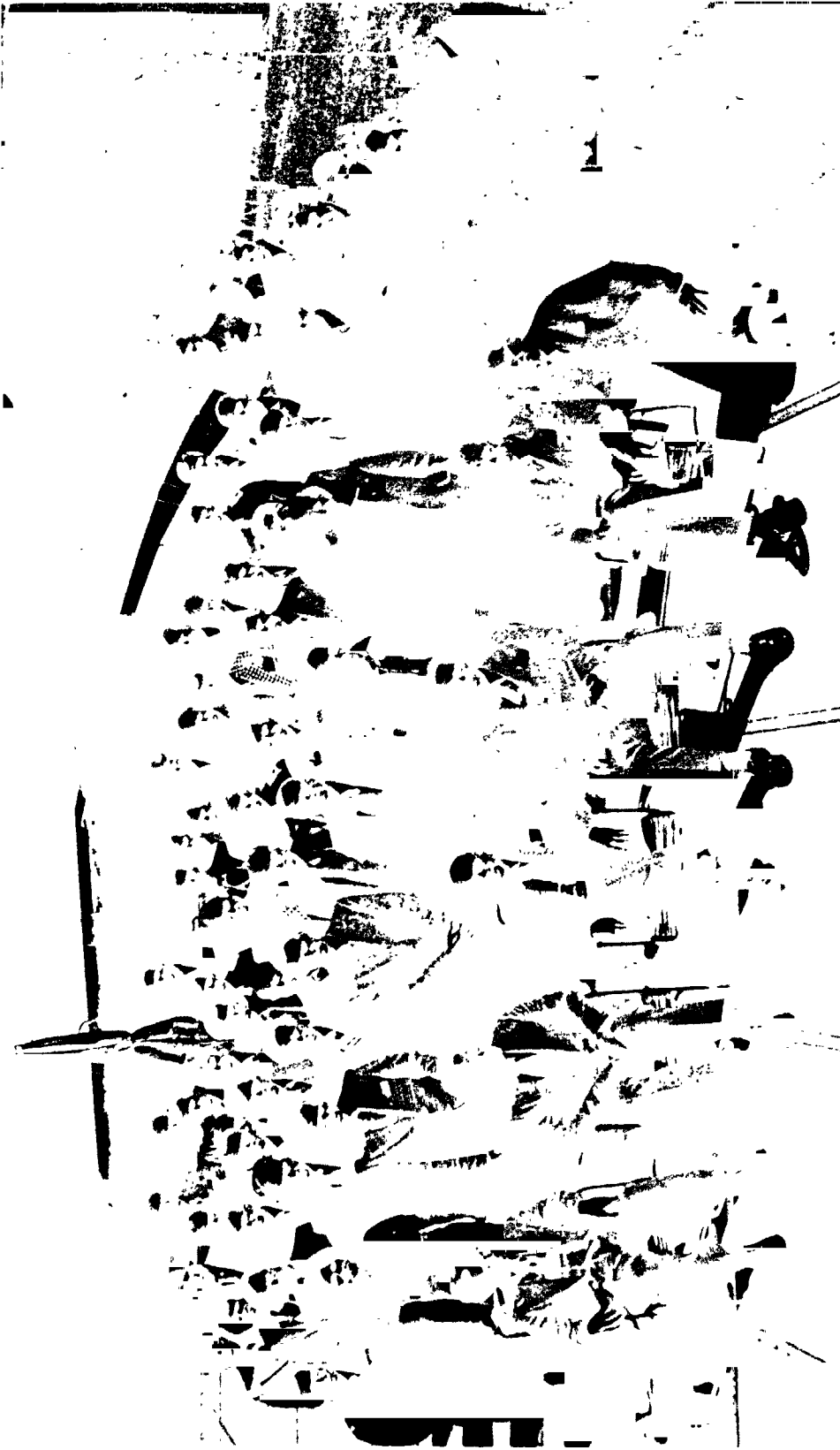

WORKSHOP DELEGATES
SECTION I EXECUTIVE SUMMARY

ORIGINAL PAGE IS
OF POOR QUALITY

79-17414

EXECUTIVE SUMMARY

Walter Frost, Dennis W. Camp, John W. Connolly

John H. Enders, Joseph F. Sower, and Harry L. Burton

Organization Committee

The Second Annual Workshop on Meteorological and Environmental Inputs to Aviation Systems is sponsored by NASA, NOAA, and FAA and hosted by The University of Tennessee Space Institute. The purpose of this as with the previous workshop is to bring together various disciplines of the meteorological aviation community, i.e., meteorologists, pilots, airline personnel, general aviation operators, manufacturing industry personnel, researchers, forecasters, engineers, instrument specialists, and military users, in round-table discussion to establish and identify needs of the aviation community relative to weather phenomena. The proceedings of the first workshop document the inputs from this vast number of disciplines relative to our understanding and knowledge of the interaction of the atmosphere with aviation systems, to the better definition and implementation of service to operators, and to the collection and interpretation of data for establishing operational criteria relating the total meteorological inputs from the atmospheric sciences to the needs of aviation. This year's effort utilized the recognized needs and deficiencies identified from the previous workshop as a basis for discussion of possible solutions and means of prioritizing and implementing these solutions.

The specific topic areas which were addressed in the committee discussion are: (1) severe storms, (2) turbulence, (3) icing, (4) visibility, and (5) lightning. These topic areas were addressed in regard to how they impact: (1) aircraft operations, (2) human factors, (3) aircraft design, (4) weather services, and (5) data acquisition and utilization. Fixed committees, having the first five titles, met with each of five floating committees, having the latter titles. The chairman of the committee then documented, from the results of the discussion, the most pressing needs, in order of decreasing importance, within the context of his committee's specific topic area. The nature of the problem as to whether it is operational, R & D, lack of data, procedural, etc. is stated in the committee report. Through committee discussion the question as to how soon the problem can reasonably be solved and what impact on aviation is likely to occur if the problem is not addressed has been queried. In turn, each problem area has been assessed as to the cost benefit of its solution, and as to whether the knowledge is in hand or whether a new effort is required to effect the solution. Finally, the committee has recommended which organization(s) (government and/or industries) should be involved in the problem solution and what their respective role should be.

A summarization of the committees' findings relative to the five topic areas of severe storms, turbulence, icing, visibility and lightning is given below.

Severe Storms

The Severe Storms Committee's topic area logically includes turbulence, icing, and lightning. However, in summarizing discussions relative to severe storms, emphasis is placed on wind and wind shear hazards.

The committee findings gave equal priority to the problems of improved detection capabilities for wind shear, hail, turbulence and lightning and of improved communications of available information to the pilot. With regard to wind shear detection, the wind anemometer array system is considered to be an interim solution and continued development of ground based Doppler radar and Doppler lidar should be accelerated to provide wind data along the glide slope. Also, in the airborne realm, further methods to indicate wind differences between that at flight altitude and at touchdown should be pursued, including airborne Doppler. The committee noted that gust front and low level wind shear occur at relatively undeveloped airports, in addition to the main metropolitan airports, and that these situations are of concern to both private and commercial pilots.

Improved communications are required to rapidly assimilate and communicate the information which is available on weather hazards to the pilot. Although the capability to observe some severe storm parameters is limited, the inability to communicate those that are observed has been repeatedly demonstrated.

In addition to the Severe Storm Committee's discussion in this regard, a recurring theme throughout the whole proceedings was the need to provide real time or near real time hazardous weather information to the pilot. The Severe Storms Committee suggested that thought be given to innovative ways for data presentation to the pilot. Examples suggested are:

1. A UHF TV channel allocated to one-way weather briefing in the ARTCC.
2. A data link from air route traffic control center to aircraft.
3. Development of simplified oral communication or expansion of the broadcast capabilities of FSS for reception down to the minimum en route altitude.
4. Means to ease the flow of weather information to the pilot during pre-flight planning.

Many of the floating committees also expressed the need to establish procedures for putting the great sums of information currently available to use in both pre-flight planning and in the cockpit. The human factors committee summarized information on wind shear needed by the pilot in order to make the decision of whether to land or to go around as follows:

1. Provide more information on preceding occurrences of weather.
2. Provide exact information relative to gust intensity.
3. Increasing the speed of the information loop by providing flight path angle, ground speed, or detecting information in head-up or tactical mode.
4. Insuring monitoring and takeover procedures.
5. Providing suitable training experience by use of simulation that includes such items as proper thrust management and use of available information.

Expanded education and training is also of considerable importance relative to severe storm aviation hazards. Special traveling courses to be established and presented to the aviation community at selected intervals to coincide with the advent of hazard weather seasons are recommended. Until a simplified method of acquiring weather information is developed, a checklist should be developed for acquiring various types of weather information or other flight information during various stages of flight. Courses should also be planned and developed which provide information on interpretation of severe weather information and reports.

Educational programs should not only be directed to the pilot, but should also be presented to air traffic controllers, national weather service forecasters, and flight service station staffs before each season.

The theme of education and dissemination of information was consistent throughout all committee reports. The Aircraft Design Committee reported that increased effort and studies to optimize pilot techniques for operation in previously undetected wind shear should be undertaken, and the results of these studies widely disseminated throughout the industry. The Aircraft Operation Committee noted the areas of severe storms and turbulence appear to be full of new programs, and the need for continuing education of pilots and air traffic service personnel is apparent. This committee noted that the new operational programs that are being introduced by the FAA and the National Weather Service will go a long way in improving the severe storm problem; however, the current major deficiency appears to be a lack of understanding on the part of pilots and controllers and how the information made available by these new programs will be utilized. This situation is complicated by the fact that air to ground communication is approaching the saturation point, particularly in the terminal area.

The Weather Service Committee's recommended action included the development and carrying out of a program to educate users of the National Aviation Systems on the availability and use of weather service information.

Finally, the Severe Storm Committee addressed the problem of improved forecasts which was an issue stressed by practically all committees and speakers throughout the course of the workshop. Increased accuracy of short term forecast was stressed. In his key note address, General Rowe emphasized that significant improvement in 0-2-hour forecast holds great promise for aviation, and it is in the short and very short range time frames that we should collectively concentrate our efforts. General Rowe commented that, in general, the USAF does a pretty good job of forecasting the onset of strong, gusty winds at a terminal but cannot reliably forecast the timing, frequency and strength of the peak gusts. Moreover, General Rowe noted that winds for flight planning require better forecasting. This requirement comes about because of fuel economy which has resulted in computerized flight plans of high sophistication. The advanced version of these flight plans not only selects the optimum interim flight path and profile based on forecast wind and weather conditions, but also the optimum climb out and let down profiles en route, all aimed at maximum utilization of available fuel.

In his overview paper, Jack Connolly pointed out, in the list of critical things that need to be done to reduce the hazards of severe storms, the need to provide more surface weather observations as input to the 0-2-hour forecast program and to accelerate development of automatic weather stations to provide these observations.

Turbulence

The Turbulence Committee had the following recommendations. Continued research is needed for understanding and describing turbulence in wind shear. Wind shear effects in terminal operations remain one of the most serious problems in aviation meteorology. Existing data on turbulence and wind shear from aircraft and towers should be exploited to the fullest.

Design models of turbulence used in evaluation of maximum loads, fatigue, and control are based primarily on measurements. Although current models are presently serving the purpose, additional turbulence data collection programs are warranted. This would lead to more realistic and comprehensive models of turbulence, especially important for future generation aircraft. More data on turbulence extremes is needed for an improved understanding of the marginal conditions or worst cases an aircraft must be designed to withstand. The effects of spanwise gradients or gust velocity should be studied. This was expressed as a strong need.

The discrete gust design approach should not be neglected relative to continuous turbulence spectral density approaches. And the committee strongly endorses a planned NASA program to reinstate and expand the earlier VGH program. The design committee interjected that structural design should be based on the design envelop for critical conditions approach rather than the mission analysis approach. Roger Moorehouse stated in his overview paper that a standard model of turbulence and wind shear is required for flight quality validation and it should include effects such as visibility, precipitation, etc. Also, a user's manual is required in addition to the meteorological model of atmospheric dynamics. He suggested a fruitful area of research relative to turbulence simulation modeling is low altitude flight measurements along typical glide slopes as well as at constant altitudes.

It was generally agreed among the committees that present capabilities and facilities should be used to fill gaps where more experiments are found to be needed, e.g., the NASA MAT program should continue with spanwise turbulence measurements including correlations, and emphasis should be placed on probing low altitude approach in worst case conditions. Severe turbulence at low altitudes should also be investigated further through tower based measurements. Improved models for design simulation should result.

The Design Committee also recommended that workshops between aircraft engineers and meteorological specialists relative to design and operation of aircraft in turbulence would greatly aid in directing the research and development work with needs to continue.

Although the basic approach to handling clear air turbulence (CAT) is to avoid it wherever possible, forecasting of CAT is still in the primitive stages. Even more serious is that although commercial and military aircraft receive CAT forecasts, general aviation pilots do not get such specialized forecasts of turbulence for their flights and aircraft types. Priority therefore should be given to the development of satisfactory on-board sensors for detection and warning prior to clear air turbulence encounters. General Barry Rowe reported that the problem with identification and location of clear air turbulence still exists. He noted that the evaluation of airborne detection systems with the optimum goal of identifying and quantifying these turbulent regions well in advance of their penetration are now being assessed. Jack Conolly, in turn, listed research concentrating on the detection and forecasting of clear air turbulence as a critical item.

Reports of CAT encounters by airline pilots are proving to be very effective in allowing other aircraft to avoid encounters. The reports, however, vary from aircraft to aircraft and pilot to pilot. The Turbulence Committee therefore expressed a need for a standard terminology in reporting clear air turbulence. This must include the development of a simple (indices), consistently understandable (quantitative) description of turbulence which accounts for or can be used with aircraft response characteristic information.

A basic question relating to the usefulness of remote sensing instrumentation for detecting and avoiding CAT was how reliable the system would be. It was noted that if a CAT detection device were used, a pilot could tolerate some false warnings, but nonforecast encounters would have to be very light for the pilot to retain confidence. A pulse Doppler lidar detector for CAT is presently undergoing development and feasibility testing (NASA/Marshall) for use from aircraft over a range from 600 m to about 15 km. An infrared radiometer CAT detector (NOAA) has also been developed and is being evaluated.

Use should also be made of en route information from airlines on winds and turbulence and related to satellite and other meteorological information, leading to reporting, mapping, dissemination, and use in aircraft operations of these data. Similarly, with terminal area winds and

turbulence data collected from airlines on landing, correlations to synoptic conditions and local variables available should be studied and related to operational needs. There is a need for methodology to quickly get turbulence information to pilots to make judgements. It should permit the pilot to judge the expected impact. Opportunities presented by meteorologists being placed in ARTC centers should be pursued in connection with turbulence evaluation (both CAT and low level). The turbulence investigation should thoroughly study and establish relationships to surface and satellite based meteorological data.

The Turbulence Committee along with many other committees recommended educational programs. These programs should incorporate training on turbulence description and its effect on aircraft response, and similar programs to those currently available to airline and military pilots should be developed and made available to the general aviation pilots. The program should be directed to describing where turbulence may be found and expected, as well as recognition of clues indicating probable encounters. Education is of fundamental importance because such background is needed in flight planning. Inflight familiarity with visual clues is needed to identify areas of turbulence during VFR operations while knowledge of the availability and training in the use of weather radar or lightning displays are essential during IFR operations.

There is also a need for providing training and experience in the physical aspects of severe turbulence in anticipation of the rare encounter. Such a procedure requires adequate simulation facilities, and to date such turbulence can be provided only by a few research systems. It was also pointed out that turbulence modeling for simulators needs improving and that these improvements should be possible with the current state of the art.

The Air Force is currently assessing the question of whether to include wind shear in training simulators. It is suggested that airline pilots could equally well benefit from simulation training in the effects of turbulence, wind shear, etc. The use of simulation may be especially beneficial for terminal operations.

Finally, there was frequently indicated a need for increased dialogue in aviation meteorology. It is necessary to have face-to-face interaction between groups of scientists, engineers, and operation personnel with different backgrounds. More conferences and workshops are needed to match specific needs with research goals and products.

Icing

The Icing Committee identified the following list of problem areas:

1. Instrumentation
2. Facilities
3. Forecasting
4. Design criteria
5. Data

Other problem areas identified by the floating committees are pitot static system icing problems, carburetor icing problems, antenna icing effects upon radio static, and ground frost formation and methods of removal. The committee concluded that although the range of icing parameters had been thoroughly researched in the 1950's, the advent of the helicopter and other low speed, low altitude aircraft such as the U.S. Air Force A-10 and cruise missile requirements, and large numbers of low altitude fixed-wing aircraft, have generated other problems that require additional R & D effort and reexamination of the meteorological design criteria.

Instrumentation: Instrumentation capable of measuring various icing cloud parameters is necessary for icing research, certification flight tests and operational usage. The primary parameters requiring accurate measurement include cloud liquid water content, droplet size, and outside air temperature. In addition, because of the unknown influence of cloud ice crystal content and the conditions produced by a combination of supercooled liquid water and ice crystals (mixed icing conditions), the need for instrumentation to measure ice crystal content has recently been identified as a research need. This need to develop instrumentation capable of quantifying ice crystal content simultaneously with supercooled liquid droplet characterization is immediate.

Facilities: Recent helicopter icing R & D efforts have once again led to the conclusion that reliance upon natural icing testing for certification purposes is very costly, time-consuming, and uncertain. The upper limits of meteorological design criteria are rarely encountered requiring extrapolation of test data for certification purposes.

A large number of military and civilian helicopters and possibly light fixed-wing aircraft are expected to be designed for flight in icing conditions during the next few decades. Without adequate simulation facilities, certification of these aircraft for flight in icing conditions will be a difficult and costly task. The recommended solution to this problem is the improvement of existing simulation facilities and development of new simulation facilities, all for use in icing research, and in development and certification procedures to reduce the reliance upon natural icing testing. Several facilities currently exist, but each has limitations that must be overcome. The proper mix of facility types is not known at this time, and the committee recommends that the first step in the solution of the problem is for NASA, FAA, and the military services to jointly participate in a facility study effort to determine the proper mix of simulation facilities and to develop a program to obtain a commonly agreed-upon goal. Use of modeling techniques to supplement or reduce facility requirements should be considered in this study. Facility improvements, developments, and operation are considered a NASA responsibility.

Forecasting of icing conditions: The weather service committee recommended action relative to an urgent need to improve the capability to forecast icing conditions and suggested additional effort be devoted

to the use of model application. The Icing Committee, in turn, reported that ice forecasting is judged to be accurate approximately 50% of the time, resulting in the military helicopter fleet being grounded in certain areas approximately 30% of the time during winter months because of forecast icing conditions. In turn, numerous inadvertent icing encounters have been reported when no icing forecasts existed. It is expected that unprotected general aviation aircraft would have similar encounters with unforecast icing, but this was not confirmed during the committee meeting. An FAA study is recommended to resolve this issue.

More accurate forecasts are necessary to allow availability of unprotected military and civilian aircraft (helicopter and fixed-wing) to be improved; forecasts need to be improved to the extent that the icing severity level can be stated. It was the consensus of the committee that the icing severity level should be stated in quantitative rather than subjective terms such as trace, light, moderate, etc. A concurrent theme was also expressed by many of the floating committees. It was also believed by the icing committee that installation of icing severity indication systems, similar to those planned by the Army, on commercial and other ice protected aircraft would benefit the National and the Air Force Weather Service in acquiring needed data for improvement of icing forecasts.

Design criteria: It is recommended that a joint government agency reassessment of meteorological design criteria contained in the FAR and MIL-SPECS be undertaken with respect to the various aircraft categories to recommend necessary or appropriate revisions. It is recommended that NASA lead this effort. Work performed in the development of Army helicopter meteorological criteria could be used as the basis. The aircraft design committee noted, in the area of testing and certification, that there is the strong need for a thorough study to determine the most effective tools for completing certification testing. It appears that considerable expenditures may be involved in developing the required facility improvements, but the cost effectiveness of using the various test facilities should be thoroughly examined.

Meteorological data: The meteorological data base is considered inadequate for accurate forecasting, both in real time and for flight planning purposes for determination of the frequency of occurrence of icing conditions and severity levels below 1500 feet, and for forecast modeling purposes. The resolution of this lack of meteorological data can only be achieved by the acquisition of more data. It was concluded that more observations, either more frequently or more closely spaced, should be considered in combination with remote sensing of liquid water content and quantified pilot reports. The Icing Committee could not establish the proper mix of data acquisition methods that would cost effectively resolve the meteorological data base problem. They recommended that this problem be addressed by NOAA and the Air Weather Service to determine the most cost effective method of filling the data needs and implementing the necessary programs.

The Human Factors Committee addressed some other areas of concern relative to icing. From a human factors point of view, continuing education and training are and will be continually necessary with respect to icing problems on aircraft. These problems deal with misinterpretation of pitot static icing indications, degradation effects of structural ice on communication and navigational signals and lack of standard procedures relative to aircraft carburetor icing. Thus, the committee on human factors concluded there remains a continuing need for information and training regarding the recognition and appreciation of the effects of icing. The FAA would seem to be the organization to seek some standardization of procedures, e.g., in the application of carburetor heat as well as the use of fuel additives to prevent carburetor icing. Required research for ice detection and warning should be primarily NASA's responsibility, with the requirement for FAA's support and for other government support of R&D efforts.

Visibility

The Visibility Committee expressed a major concern relative to the impact of automatic weather stations versus the traditional human manned station. Questions of particular concern were:

1. Will sensors provide prevailing visibility?
2. Can or will instruments give the needed data for forecasting purposes?
3. Is there a justifiable requirement for prevailing visibility?

It was agreed that a definite need for prevailing visibility or a suitable substitute was required. In particular, general aviation has a continuing and critical need for prevailing visibility data. The projected closing of flight service stations (FSS), coupled with the shift towards systems automation, establishes a clear requirement for a sensor system to provide this information reliably and automatically. The data acquisition and utilization committee felt that there was also a need for an instrument system with scanning capability to measure visibility in the direction of the glide path, a day/night capability to determine slant range visibility, and a low cost day/night ceilometer. Low cost automatic weather stations using such sensors are needed at over 1,000 general aviation airports which have published IFR approaches but which currently have little or no weather observation data.

The Visibility Committee also were of the general consensus that there is a valid requirement for a system to determine slant range capability. Funds to continue the program of research and development of a system to measure slant range visibility were recommended. The committee did, however, feel that some policy decision must be made concerning the future use of slant range. Questions relative to this decision are whether slant range will become of regulatory value used

for minimums and replace RVR or will it be used in an advisory fashion? The Weather Service Committee in turn reported that the measurement of slant range visibility is a serious problem which needs additional emphasis. The Human Factors Committee also recommended continued research and development efforts relative to the ability to supply slant range visibility measurement, particularly as an instantaneously available readout to the pilot. They felt primary responsibility in these areas rests with NASA, NOAA, NWS, or other Government research agencies with a user input to the evaluation of such advanced techniques and displays.

The Visibility Committee expressed concern over the fact that with 12 major airports planning to go to Category IIIB operations there is lack of weather data to determine the frequency of Category III weather. Charlie Douglas, in his overview paper, questioned whether the lower limit of Category IIIB, 150 feet, is realistic. He felt points to be considered in operational Category IIIB are:

- (a) the visual aids currently specified by ICAO are designed for operation down to an RVR of 300 ft;
- (b) cost benefits associated with design for visual operations down to 150 ft RVR.

The Visibility Committee concluded, however, that efforts should be continued to develop systems to report visibilities in Category IIIB approach conditions. Improvement will also be needed in visibility measuring equipment to provide RVR measurement below 600 ft and of less than the present 200 ft intervals. Also, they noted as Category III operations are implemented a need for landing runway guidance once on the ground becomes necessary.

Like all committees, the Visibility Committee reported that a most fruitful area for improvement deals with education and training. In the area of training the new flight simulators offer great potential. Modern simulators can provide realistic reduced visibility training.

Inflight visibility is of particular interest to general aviation, and the pilot report is the most accurate and helpful to others flying in the same area. Improvements are being made and FAA's en route flight advisory service (EFAS) and meteorologists in the air route traffic control centers (ARTCC) offer significant opportunities to provide the aviator with better, near real-time weather information. However, the pilot must be educated to their use and how to make useful PIREPS. The human factors committee considered reduced visibility as one of the most important areas discussed by the committee. They pointed out that one must be careful in relying upon training in place of other solutions related to hardware improvement and other aids, however. They summarized that the experience gained through realistic simulation exercises involving transition from IMC to VMC, or VMC to IMC, and the use of available information and cues is difficult to obtain. Responsibility for this training is at present spotty and rests primarily with the operator and independent training organizations.

Lightning

The lightning and static electricity committee concluded the following:

1. An adequate lightning protection technology base and personnel with sufficient experience to apply it exists within the design organizations for most military and transport-category aircraft presently being built. Adequate formal, comprehensive standards and specifications, however, do not exist.
2. An adequate understanding of lightning protection technology does not generally exist among designers of general aviation aircraft. Whereas lightning has not been considered a serious hazard to these aircraft in the past, greater use under IFR conditions has increased their susceptibility and the number of reported lightning strike instances is increasing.
3. Trends towards use of nonmetallic structural materials, adhesive bonding techniques, and reliance upon sensitive electronics to perform flight-critical functions pose potential hazards for all categories of future aircraft unless new protection technology is developed, documented and made available to designers.
4. Pilots of all aircraft need a better understanding of the conditions under which lightning strikes can occur and the effects it may have upon their aircraft. A better understanding will improve avoidance procedures, equip pilots to react knowledgeably when a strike occurs, and enable better information to be achieved from pilot reports of inflight strike incidents.

Eight areas of technical needs were defined. The nature of each problem, timeliness and impact of solution, degree of effort required and the roles of government and industry in achieving solutions were discussed within the committee. A priority of relative importance was assigned and these factors are documented in the committee's report. The eight areas of technical need are:

1. The need for inflight data on lightning electrical parameters. The need is for a better understanding of the electrical parameters of natural lightning and of relationships existing between these parameters and effects that occur upon aircraft exposed to direct or nearby strikes. The committee gave strong endorsement to current NASA and USAF efforts at planning and implementing flight research programs in the 1978-81 time frame to gather direct and nearby lightning strike data.
2. Technology base and guidelines for protection of advanced systems and structures. The present need for lightning protection is most critical in the area of general aviation aircraft, which are being operated increasingly under IFR conditions.

However, the near future need applies to all aircraft making use of advanced technology systems and materials and will be imperative. The committee noted that few documents exist to alert the manufacturers of aircraft to possible pitfalls or to guide them in lightning protection design. Federal air worthiness regulations and military standards pertaining to lightning protection contain requirements as to what protection must be provided but do not offer any clues as to where the problem areas are likely to occur or what protection approaches should be considered.

The committee recognized the impracticality of expecting to avoid all lightning strikes, and noted that safety from this environment is obtained primarily by designing the aircraft to safely tolerate the strike it receives, rather than by reliance upon avoidance procedures. The need for an adequate protection technology data base and practical design guidelines based upon these data were therefore considered the central need.

3. Improved laboratory test techniques. Improvements are needed in tests to evaluate lightning problems due to both induced voltages and blast effects. Fulfillment of this need will best be achieved by parallel efforts at industry and government research laboratories, with correlation of results and definition of standardized tests accomplished in government/industry forums such as the Society of Automotive Engineers (SAE) Committee AE4L on lightning test techniques.
4. Analysis techniques for predicting induced voltage effects. The committee noted the desirability of having analytical tools with which to predict the level of lightning induced voltage in aircraft's electrical circuits before hardware is built and available for tests. However, measurements of actual strike data are important to clarify and improve analytical techniques.
5. Lightning strike incident data from general aviation. The committee acknowledged the large store of lightning strike incident data already being collected from airlines and the military, but as yet practically no such data has been accumulated for smaller, general aviation aircraft. The possibility of organizations such as the Aircraft Owner and Pilots Association distributing questionnaires to its members for the use in recording lightning strikes was recommended.
6. Lightning detection systems. Lightning detection systems are important as a means of alerting pilots to the presence of thunderstorm activity, and on the ground, as a means of alerting ground crews to approaching thunderstorms.

7. Obtain pilot reports of lightning strikes. For pilot reporting to be successful, terminology to describe gradation of flash intensity and frequency of occurrence, etc. would have to be established and pilots would have to be educated in its use. The value of such reports would be improved avoidance of lightning strikes in thunderstorm areas.
8. Better training in lightning awareness. Pilots need a better understanding of the conditions under which lightning may occur, what lightning is, and how it may affect their aircraft, in order to better react to a strike when it occurs. Ways that such training might be provided is to include it in pilot refresher courses and training manuals. It was suggested that the first few chapters of NASA RP1008 "Lightning Protection of Aircraft" might be adequate for this purpose.

Data Acquisition and Utilization

The Data Acquisition and Utilization Committee reported that in terms of data acquisition, one of the ironies that has been highlighted in this workshop, as well as in the past by many user organizations, is the abundance of real-time weather information that is always available somewhere in the national air system--either the cockpit, en route ARTCC's, in terminals, or in Flight Service Stations. However, the means on the part of servers and users to assess this information is totally inadequate.

The problem stems from both the absence of organization to maximize the distribution of this information in today's environment and the constraint imposed by the lack of modern digital communication systems, automated data retrieval and display systems.

The committee outlined several FAA programs which are under way that address both aspects of this problem. These are:

1. The FAA has recently implemented an improved service in Flight Service Stations (FSS) called en route advisory service (EFAS). This program, however, calls for providing weather radar information, satellite photo information, and other aids to EFAS specialists, and currently most EFAS sites have not yet been equipped with the required equipment. Continued emphasis is needed to assure that this supporting equipment is provided.
2. The FAA is acquiring a new modern digital communication system, identified as the National Digital Communication Network (NADIN), which will replace the current Service B network and eventually most, if not all, of Service A.
3. Flight service station automation programs will provide modern digital (alpha-numeric and graphic) data retrieval and display

capabilities to the level 3 (43 busiest) FSS's. This system will be implemented beginning in approximately three years.

4. The FAA and NWS are currently (April 1978) employing meteorologists in the ARTCC's for the purpose of providing short-term forecasts and information on hazardous weather.*

The Data Acquisition and Utilization Committee felt that in three to six years, capability will exist to rapidly acquire, process, communicate, retrieve and display real-time weather in alpha-numeric and graphic forms. This they felt will eliminate the major problem in making the abundance of information available in the system today more accessible.

The committee also noted the proposed Discrete Address Beacon System (DABS) which will establish a digital link between airborne aircraft and the ground, and the Aircraft to Satellite Data Relay (ASDAR), a communication system developed by NASA (Lewis Research Center) to provide PIREPS from commercial aircraft in near real-time, which has been developed on a fully automated basis.

General Comments

It was a general consensus of all reported results and discussion throughout the workshop that dissemination and education relative to the current information available on aviation weather is the most pressing need. This appears to be procedural in nature. The aircraft operations committee summarized this consensus by stating that there is an urgent requirement for a joint government/industry discussion on how to best use the information available today through existing and soon-to-be implemented weather programs. These discussions must rank the order of priority as to the urgent and not-so-urgent information that is required for use by pilots and ground service personnel recognizing the many varying constraints. The aircraft operations committee also noted that the need for education of pilots and ground service personnel is never-ending and remains extremely high on the priority list of weather needs. Lack of reminders of old programs is among the most pressing needs to improve the effectiveness of weather programs. The committee also felt that there is a need for revalidating old forecasting techniques on today's airframes, utilizing modern tools with the ultimate goal of improving the users' confidence in forecasting.

Finally, there was the continuous theme throughout the workshop discussions and reported results that the FAA and NOAA must establish an integrated weather system for the National Airspace System.

Auditor's note: At the time of the conference, the FAA was internally coordinating an agency plan titled "FAA Aviation Weather System Preliminary Program Plan" which delineated many projects directed at alleviating many of the deficiencies identified during this workshop. Also, the NWS Automation of Field Operations and Services (AFOS) program provides a new high speed communications and display capability for the NWS offices.



ORIGINAL PAGE IS
OF POOR QUALITY.

SECTION II INTRODUCTION AND WELCOME



Opening Remarks

John H. Enders

Aviation Safety Technology Branch

NASA Headquarters

Good morning. On behalf of the sponsoring agencies, NOAA, FAA, and NASA, welcome to the Second Annual Workshop on Meteorological Inputs to Aviation Systems. The title of this year's Workshop reflects the positive response of last year's participants, who enthusiastically recommended a continuation of this type of conference.

In order to ensure a useful investment of valuable time, the content of successive workshops must be varied to avoid total repetition of the previous meeting. In addition, total participation must be limited to the extent of ensuring the maximum interaction between individuals as they participate in the group discussions. We invited representatives from those organizations, both in and out of government, which have key interests and roles in the various aspects of aviation weather. Some of you here today did not participate in last year's Workshop, but likely a colleague of yours represented your organization previously. This rotation of exposure to the Workshop should benefit the aviation community because it will perhaps stimulate in-house discussions which might not otherwise take place.

Last year we set out to document meteorological shortcomings in aeronautics. Inputs from meteorologists, pilots, airlines, general aviation operators, manufacturing industry, researchers, forecasters, engineers, instrument specialists, and military users are reflected in the proceedings of last year's Workshop. This year, our aim is to use these recognized needs and deficiencies as a basis for discussion of possible solutions and means of prioritizing and implementing these solutions. To aid in structuring the group discussions, the program will lead off today with overview papers that summarize current understanding of severe storms, icing, turbulence, visibility, and lightning. "Fixed" committees on these topics will interact with "floating" committees made up of experts in the areas of aircraft operations, human factors, aircraft design, weather services, and data acquisition. Each committee will provide a summary report of its deliberations and conclusions which will, along with the overview papers, be included in the proceedings. Dr. Frost will describe the Workshop format more precisely.

Again, on behalf of the sponsoring agencies, we wish you a productive two and a half days, with results which will prove helpful in informing each of us of ongoing effort and thinking and in planning on individual programs in a non-duplicative, yet synergistic, way.

DESCRIPTION OF WORKSHOP

Walter Frost

University of Tennessee Space Institute

Dennis Camp

NASA/Marshall Space Flight Center

In keeping with the format of the first Annual Workshop on Meteorological and Environmental Inputs to Aviation Systems, this workshop is again designed to devote a major portion of its time to committee meetings where the maximum exchange of information is achieved through direct communication between people from a number of disciplines in the aviation community. The fixed committees this year are assigned specific topic areas pertaining to weather phenomena, that is, the fixed committees are entitled "Severe Storms," "Turbulence," "Visibility," "Icing," and "Lightning." The floating committees in turn are entitled "Aircraft Design," "Human Factors," "Data Acquisition and Utilization," "Aircraft Operations," and "Weather Services."

The committees are made up of personnel from many fields related to aviation weather. In attendance are meteorologists, pilots (general aviation, commercial and military), scientists, researchers, planners, and educators working in the various areas of aviation systems and meteorology for government agencies, industries and universities. A list of the agencies from which people are in attendance is given in Table 1.

The major objectives of the workshop are to satisfy such needs of the sponsoring agencies as the expansion of our understanding and knowledge of the interactions of the atmosphere with aviation systems, as the better definition and implementation of services to operators, and as the collection and interpretation of data for establishing operational criteria, relating the total meteorological inputs from the atmospheric sciences to the needs of aviation communities.

Five overview papers have been invited for this morning session. These invited presentations will be in the form of assertive, informative type papers giving overviews of the areas selected for round table discussions. The papers will acknowledge past work or state of the art, assess past work in view of today's needs, identify needs not satisfied by our current data base, and suggest general options which should be explored but are not specifically product-oriented. Round table discussions will take place following the invited presentations where the five fixed committees will meet separately and sequentially with five floating committees. The make-up and organization of the committee is described below.

Committees consisting of a chairman and the membership, shown in Table 2, have been assembled to cover specific topics under the general categories. As mentioned earlier, the fixed committees are (1) severe storms, (2) turbulence, (3) icing, (4) visibility, and (5) lightning. The floating committees will be made up of members from the fields of (1) aircraft operations, (2) human factors, (3) aircraft design, (4) weather services, and (5) data acquisition and utilization. The interaction of the committees will be to address problems pertaining to their topic areas and to recommend actions necessary to effect solutions of these problems. Working sessions where the floating committees meet individually with each of the fixed committees will be conducted and the outcome and conclusion of the meeting recorded. The committee chairman will then be responsible for writing a final committee report for documentation of the workshop, in a proceeding which will be published. These write-ups will assess the problems as to range, scope and information transferal. For example, the results of the round table discussions should answer such questions as (1) needs, (2) present knowledge, (3) current methods, and (4) what information exchange between agencies is possible. The third day will be a plenary session consisting mainly of the chairmen presenting an overview of their committees' discussions and an outline of their intended write-ups. General comments and recommendations from the entire group will be called for during this final session.

TABLE 1. PARTICIPATING AGENCIES

<p><u>Government-Civilian</u></p> <p>NASA</p> <p>Headquarters</p> <p>Marshall Space Flight Center</p> <p>Lewis Research Center</p> <p>Langley Research Center</p> <p>Dryden Flight Center</p> <p>Ames Flight Center</p> <p>Goddard Space Flight Center</p> <p>Wallops Island Flight Center</p> <p>Jet Propulsion Laboratory</p> <p>NOAA/Dept. of Commerce</p> <p>National Weather Service</p> <p>National Severe Storms Lab.</p> <p>National Environmental Satellite Service</p> <p>DOT</p> <p>Federal Aviation Administration Headquarters</p> <p>National Aviation Facilities Experimental Center</p> <p><u>Companies</u></p> <p>Aeronautical Research Associates of Princeton</p> <p>Boeing Commercial Airplane Company</p> <p>Bunker Ramo</p> <p>Cessna Aircraft Company</p> <p>Douglas Aircraft Company</p> <p>FWG Associates, Inc.</p> <p>Lightning Technologies, Inc.</p> <p><u>Independent Associations</u></p> <p>Air Line Pilots Association</p> <p>Airplane Owners & Pilots Association</p>	<p><u>Government-Military</u></p> <p>United States Air Force</p> <p>Air Weather Service</p> <p>Air Force Systems Command</p> <p>Safety Center, The Inspector General</p> <p>United States Army</p> <p>Research & Technology Laboratory, Fort Eustis</p> <p>United States Navy</p> <p>Naval Air Systems Command</p> <p><u>Universities and Research Institutes</u></p> <p>University of Tennessee Space Institute</p> <p>University of Oklahoma</p> <p>University of Dayton</p> <p>Ohio State University</p> <p>Battelle Pacific Northwest Laboratory</p> <p><u>International</u></p> <p>United Kingdom Defence Research and Development Service</p>
--	---

TABLE 2. COMMITTEES

Fixed Committees

Severe Storms

Jean T. Lee, Chairman
National Severe Storms Lab
1313 Halley Circle
Norman, OK 73069
405-231-4916 FTS 736-4916

Fernando Calacena
Dept. of Commerce
NOAA-ERL-APCL
Boulder, CO 80302
303-499-1000 x6269

Norman L. Crabill
MS 247
NASA/Langley Research Center
Hampton, VA 23665
804-827-2274

John McCarthy
University of Oklahoma
School of Meteorology
Norman, OK 73069
405-325-3242

William W. Melvin
Air Line Pilots Association
1101 W. Morton
Denison, TX 75020
214-463-1246

Rance W. Skidmore
HQ Air Weather Service
AWS/SNP
Scott AFB, IL 62225
618-256-4741 FTS 256-4741

Turbulence

Charles E. Elderkin, Chairman
Battelle Pacific Northwest Labs
Box 999
Richland, WA 99352
509-946-2335

L.J. Ehernberger
NASA/Dryden Flight Research Ctr.
Box 273
Edwards, CA 93423
805-258-3311 x340/447

David J. Moorhouse
Chief/Flying Qualities
AFFDL/FGC
Wright-Patterson AFB, OH 45433
513-255-5676

Harold N. Murrow
NASA/Langley Research Center
M/S 243
Hampton, VA 23665
804-827-3451

Edwin A. Weaver
Optical Engineer
NASA/Marshall Space Flight Ctr.
Huntsville, AL 35812
205-453-1597

Guy C. Williamson
ARAP
Box 229
Princeton, NJ 09540
609-452-2950

TABLE 2. cont'd.

Fixed Committees

Icing

Richard I. Adams, Chairman
U.S. Army
DAVDL-EU-SYA
Ft. Eustis, VA 23604
804-878-2306

Garry C. Jackson
Meteorologist
AFFDL/WE
Wright-Patterson AFB, OH 45433
513-255-6626

Robert L. Klapprott
FAA
Rm. 220, Mid-Continent Airport
Wichita, KS 67709
316-942-4281

James Luers
University of Dayton
College Park Drive
Dayton, OH 45469
513-229-3921

Dennis W. Newton
Cessna Aircraft Co.
ARC Division, Box 150
Boonton, NJ 07005
201-347-5117

Porter J. Perkins
NASA/Lewis Research Center
MS-77-2
Cleveland, OH 44135
216-433-4000 x6684

Visibility

Robert L. Gardner, Chairman
Flight Safety Officer
AFISC/SEFB
Norton AFB, CA 92409
714-382-3416

Larry S. Christensen
FWG Associates
RR 3, Box 331
Tullahoma, TN 37388
615-455-1982

Charles A. Douglas
Consultant/NBS
7315 Delfield St.
Chevy Chase, MD 20015
301-656-7875

Arthur Hilsenrod
FAA/DOT ARD-451
2100 Second St. SW
Washington, D.C. 22101
202-426-8427

Ronald H. Kohl
University of Tennessee
Space Institute
Tullahoma, TN 37388
615-455-0631 x234

TABLE 2. cont'd.

Fixed Committees

Lightning

J. Anderson Plumer, Chairman
Lightning Technologies, Inc.
560 Hubbard Avenue
Pittsfield, MA 01201
413-499-2135

M.P. Amason
Section Manager
Lightning Protection
Douglas Aircraft Co.
Long Beach, CA

John A. Birken
DOD
NAVAIR, AIR52026B
Washington, D.C. 20361
202-692-3935

Phillip B. Corn
Equipment/Advanced Development Lab
AFFDL/FEA
Wright-Patterson AFB, OH 45433
513-255-5066

Joseph W. Stickle
Asst. Chief, Flight Services Div.
NASA/Langley Research Center
Hampton, VA 23665
804-827-2037

TABLE 2. cont'd.
Floating Committees

Aircraft Operations

Robert T. Warner, Chairman
AOPA
Box 5800
Washington, D.C. 20014
301-951-3923

Thomas P. Incrocci
HQS Air Weather Service, USAF
AWS/SNPA
Scott AFB, IL 62225
618-256-4741 FTS 255-4741

Ernest E. Schlatter
FAA-NAFEC
ANA-410
Atlantic City, NJ 09405
609-641-8200 x2759

Arthur Varnado
FAA AFS-4
800 Independence Ave. SW
Washington, D.C. 20591
804-827-2037

William W. Vaughan
NASA/Marshall Space Flight Ctr.
Code ES-81
Huntsville, AL 35812
205-453-3100

Human Factors

George E. Cooper, Chairman
NASA/Ames Research Center
M/S 239-3
Moffett Field, CA 94035
408-867-3335

Richard D. Gilson
Ohio State University
Box 3022
Columbus, OH 43210
614-422-8730

A. Charley McTee
Bunker Ramo
Box 218
Randolph AFB, TX 78148
512-658-5493

Maurice A. Wright
University of Tennessee
Space Institute
Tullahoma, TN 37388
615-455-0631 x216

Andy D. Yates, Jr.
Air Line Pilots Association
7413 Park Terrace Drive
Alexandria, VA 22307
703-765-7423

TABLE 2. cont'd.
Floating Committees

Aircraft Design

John T. Rogers, Chairman
Boeing Commercial Airplane Co.
Box 3707
Seattle, WA 98124
206-237-1453

Edward F. Blick
School of Aerospace
University of Oklahoma
Norman, OK 73071
405-325-5011

Nigel Gregory
British Defense Staff/UK DRDS
3100 Massachusetts Ave. NW
Washington, D.C. 20008
202-462-1340 x2569

John C. Houbolt
MS 116
NASA/Langley Research Center
Hampton, VA 23665
804-229-5434

Richard L. Kurkowski
Flight Systems Research Div.
NASA/Ames Research Center
Moffett Field, CA 94035
415-965-6219

John A. Lasley, Jr.
Chief/Staff Meteorology
ASD/WE
Wright-Patterson AFB, OH 45433
513-255-2207

Weather Services

Loren J. Spencer, Chairman
FAA, ASF-30
800 Independence Ave. SW
Washington, D.C. 20591
202-426-2604

Robert Bell, AAT-360
FAA
800 Independence Ave. SW
Washington, D.C. 20591
202-426-8802

Edward M. Gross
National Weather Service
8060 13th Street
Silver Spring, MD 20910
301-427-7726

Ernest A. Neil
Chief/Meteorology Program Office
NASA/Goddard Space Flight Center
Greenbelt, MD 20771
301-942-3038

Charles H. Sprinkle
National Weather Service
8060 13th Street
Silver Spring, MD 20910
301-427-7726

TABLE 2. cont'd.

Floating Committees

Data Acquisition

Mikhail A. Alaka, Chairman
National Weather Service
W424
Silver Spring, MD 20910
301-427-7772

Bruce L. Gary 654-3198
Jet Propulsion Lab
4800 Oak Grove Drive
Pasadena, CA 91103
213-354-3198 FTS 792-3198

Loyd C. Parker
NASA/Wallops Flight Center
Wallops Island, VA 23337
804-824-3411 x640
FTS 928-5640

Frances C. Parmenter
National Environmental Satellite Ser.
World Weather Bldg., Room 601
Washington, D.C. 20233
301-763-8282 FTS 763-8282

Robert J. Roche
FAA ARD-404
2100 Second St. SW
Washington, D.C. 22101
202-426-2804

Robert Steinberg
NASA
Lewis Research Center
Cleveland, OH 44135
216-433-4000 x6677

Welcome Remarks

Charles A. Lundquist
Space Sciences Laboratory
NASA/Marshall Space Flight Center

Meteorological factors influencing aircraft safety recently acquired a very personal significance to those of us at the Marshall Space Flight Center. The loss of a commercial airline flight out of Huntsville took with it close associates of ours. Meteorological circumstances contributed to this tragedy. Therefore, this Workshop seems to us manifestly important.

On a less tragic note, as I reflected on the contents of this conference, I was impressed with the convergence of several disciplines. Many common meteorological factors influence both aircraft and rocket flight through the atmosphere. This fact is an historical basis for Marshall's involvement in the aircraft aspect of the topic, inasmuch as our attention to the rocket aspect is mandatory. The development of the space shuttle, a craft that launches as a rocket and lands as an aircraft, makes the ties even closer. Just a few days ago, the shuttle Enterprise landed on its 747 carrier in Huntsville.

The second Orbital Flight Test (OFT 2) of the shuttle, its first flight to carry scientific investigations, will carry an experiment to measure the occurrence of lightning in thunderstorms. On one hand, this measurement is pertinent to the issues of this Workshop. On the other hand, some authorities believe that atmospheric electrification in thunderstorms is a key link in the process by which the Sun influences weather and climate. The OFT 2 experiment will also be pertinent to the investigation of this hypothesis.

Still later in the shuttle era, an Atmospheric Cloud Physics Laboratory will be carried within the Spacelab. In the micro-acceleration environment of free flight, this laboratory will study the physical processes of cloud formation. Again, the implications for environmental inputs to aviation are obvious.

These are but a few examples of the natural convergence of several disciplines. I hope they will underline the significance which the Marshall Center attaches to this Workshop.

Welcome

Charles H. Weaver

Dean

The University of Tennessee Space Institute

The University of Tennessee and the University of Tennessee Space Institute welcome you to this Second Annual Workshop on Meteorological and Environmental Inputs to Aviation Systems. We are pleased that NASA, NOAA and FAA found last year's conference to be so beneficial that you are beginning another workshop on our campus. Be assured that we consider it a privilege to make your stay here pleasant and informative as you consider multidisciplinary matters vital to progress in aviation.

Your scope of activities is completely consistent with the concept Dr. Frost has for the Atmospheric Science Division and, in a more general sense, is quite in agreement with the multidisciplinary approach we have adopted for our diverse engineering and scientific efforts. We thank Dr. Frost and his colleagues for their efforts in arranging for this second workshop. It is our wish that you from industry, government and universities will have a mutually beneficial informational exchange experience.



**SECTION III
BANQUET
PRESENTATION**



**ORIGINAL PAGE IS
OF POOR QUALITY**

Aviation Meteorology - Today and the Future

N70-17415

Brigadier General Berry W. Rowe

Commander, Air Weather Service, USAF

Ladies and Gentlemen, I want to say at the onset that I sincerely appreciate the opportunity to speak to you this evening. It's not very often that I get to speak to an audience that is deeply interested in the subject that, for the most part, pays my bills-- the support to aviation systems.

I want you to consider my talk as an assessment of the present state of aviation meteorology, and what I think is the prognosis for the future. You may find some of my remarks controversial, but I think they need to be stated, if for no other reason than to stimulate some thinking.

Let's consider three categories of meteorological support to aviation systems: terminal weather, the winds for flight planning, and en route flight hazards.

There are several meteorological elements which can impact the safety of flight operations in the terminal area, low ceilings/visibility, low level wind shear, wake turbulence, icing, thunderstorms, and strong or gusty surface winds. For my purpose, the terminal area is defined as the airspace between the surface and 2000 ft and a radius of five nautical miles of the airfield. There are many ongoing programs to facilitate the handling of terminal area problems.

Low ceiling and visibility continues to be a perplexing problem, both from the viewpoint of the meteorologist and the flight scheduler. Simply stated, we have difficulty forecasting the onset, duration, and extent of low ceilings and visibilities. For example, in 1977 we verified two hundred feet/one-half mile conditions 26 percent of the time; at one thousand feet/two miles we did some better, 41 percent. The aviation community has chosen to pursue fog dispersal systems and cloud seeding techniques to help resolve this problem. Even though some of these techniques use brute force and require optimum meteorological conditions before being effective, they are at least as reliable as the forecasts.

Low level wind shear in the terminal has sprung to the forefront in the last couple of years, primarily because of accidents directly attributable to the phenomenon. Needless to say, many of you could provide me great insight into the low level wind shear problem.

PRECEDING PAGES NOT FILMED

The main thrust in this area is to pursue the development of ground based systems. The Air Force is awaiting the outcome of FAA and NOAA efforts before committing hard cash to a deployable ground based low level wind shear system. We have made some strides in our ability to advise aircrews of the onset of low level wind shear based on forecast meteorological events. The advisory techniques used by the weather services could probably be classed as grassroots, but it is a beginning. As we gain operational experience in forecasting low level wind shear, our reliability and confidence will surely improve.

Increased pressures to minimize longitudinal separation distances between aircraft has been brought about by rapid growth in air transportation. Wake vortices are extremely critical in the terminal area when aircraft are in the take-off and landing phases of their flight and where over-crowded conditions exist at many of our nation's airports. The development of a vortex advisory system now undergoing testing at Chicago's O'Hare is a giant step forward in addressing this problem. Operational vortex advisory systems at the nation's busiest airports may increase their utilization as much as 30% or more. The wake vortex problem, while important within the Air Force, is subdued by a decrease in flight operations at many of our airfields, and no stringent requirement to stack our aircraft as tight as possible for take-offs and landings. However, the importance of the phenomenon does increase during simulated or actual national emergency situations.

Aircraft icing is somewhat unique when compared to other terminal area problems. Although the problem has existed since the advent of aviation, its impact on aviation systems was not prevalent for many years due to the proliferation of onboard deicing or anti-icing equipment. I attribute the recent interest in aircraft icing problems to two developments: the significant increase in the number of rotary-wing aircraft and the decrease in on-board anti-icing or deicing equipment in modern day jet aircraft. This is especially true when describing new or future military aviation systems. This state of affairs has been brought about by increased monetary constraints, with little or no decrease in the requirement to modernize our aircraft systems. What are we doing to deal with the icing problem? Quite frankly, not much. We've relied too heavily on the engineers to effectively deal with the problem with onboard systems and have neglected efforts to reliably forecast the phenomenon. Therefore, we are currently behind the eight ball and find ourselves in a catch-up mode. The military services, through their various research arms, are now starting to address the problem. There is a pressing need to improve our aircraft icing forecast capabilities within the terminal area, both from the viewpoint of reliability and mission tailoring. NASA is doing likewise for the civil aviation community. We look forward to cooperative efforts in this area to arrive at the optimum solution.

It would be interesting to note how many times we have heard or read something to the effect, "Don't take off or land in thunderstorms." Still we hear year after year where some brave soul has decided to neglect this warning and gets blown off the runway or slammed into the ground. Why does this happen? Is it just human nature to challenge the elements or is it our inability to provide adequate warning on an approaching thunderstorm? It's probably a combination of both. We have ground-based radar coverage of all terminal areas to pinpoint the location, direction of movement and intensity of approaching convective cells. But does that cell have an associated gust front or lightning? These two problems are being challenged by the development of surface based systems for detecting approaching gust fronts and lightning discharges. I feel quite confident that our progress in the development of Doppler radar systems holds the key for a better understanding of internal thunderstorm mechanics which will ultimately lead to increased warning of surface based phenomena associated with a particular storm. I applaud the joint development efforts now underway in this area.

I want to say just a few words about the last of the terminal area problems, strong or gusty surface winds. This is a difficult problem, needless to say. Wind sensors tell us when the phenomena is occurring, not when it's about to occur. Computer models have been developed to simulate or predict peak wind gusts, but unfortunately, our inability to accurately portray the true state of the atmosphere limits the usefulness or accuracy of such models. In general, we can do a pretty good job of forecasting the onset of strong or gusty winds at a terminal, but what we can't do reliably is forecast the timing, frequency, and strength of the peak gusts. Can we do better? Quite seriously, I'm not sure, but I hope so.

The second category of meteorological support to aviation systems that I want to consider is winds for flight planning. The Air Force has expended considerable effort in this area over the past 5-8 years. Has it been to simply provide computerized flight plans tailored to specific missions, or has it been to choose the optimum flight path between point A and B so as to arrive at point B in the shortest possible time? It has been a combination of many things, but the driving factor in the last few years has probably been fuel economy. Our computerized flight plans are becoming quite sophisticated. The advanced version not only selects the optimum en route flight path and profile based on forecast wind and weather conditions, but also the optimum climbout and let down profiles and routes, all aimed at maximizing utilization of available fuel. Some of the airlines have chosen the computerized flight plans as their way of beating spiraling fuel costs. I only wish we could provide better winds to produce our flight plans. Once again, this points out our inability to accurately portray the true state of the atmosphere.

The last category of meteorological support to aviation systems is en route flight hazards. History has shown us that most major aviation accidents occur in the terminal area during take-off or landing phases of flight. Occasionally accidents, such as the Southern Airlines crash in Georgia last year or our own C-141 crash in England in August 76, bring the total picture into focus once again. Could these accidents have been avoided? Maybe they could have been. Thunderstorms, turbulence, icing and lightning or electrostatic discharges are the major producers of en route aviation accidents or incidents. The monies dedicated to research in these specific areas reflect their potential impact on aviation systems. The thunderstorm, being the most dramatic, has received considerable attention over the years; still, we lack much of the information necessary to accurately depict and define thunderstorm dynamics. Therefore, we are pursuing the development and deployment of advanced airborne radar systems to assist aircrews in the identification and location of severe weather. Airborne Doppler radar may well hold the key for guiding aircrews safely through the penetrations of thunderstorm cells. Advanced radar display capabilities have taken much of the guesswork out of radar scope interpretation. I hope we can now get the cost down to the point where general aviation and, I might add, the military can afford them.

The second and most critical en route hazard affecting aviation is that of turbulence, both mountain wave and CAT. Techniques for forecasting mountain wave turbulence are well known throughout the meteorological community and have achieved a high degree of reliability. Unfortunately, not all mountain wave activity occurs in text book fashion which leaves some doubt in the mind of the beholder. Cap clouds or roll clouds are not always prevalent as a visual cue to warn approaching aircrews, leaving doubt as to the existence of wave activity. This same problem occurs with the identification and location of clear air turbulence areas--no visible cues are present in most cases. Researchers are now evaluating airborne detection systems with the optimum goal of identifying and quantifying these turbulence regions well in advance of their penetration. The Air Force will become more and more interested in airborne systems as our air frames age or become more sophisticated and expensive.

Another significant en route flight hazard is aircraft icing. My earlier comments concerning icing problems in the terminal area also apply here. The reluctance to get too concerned about icing problems is further impacted by the fact that en route modern day jet aircraft fly at altitudes above the icing region. Those aircraft operating within the icing region have previously been equipped to deal with its occurrence, should it arise. Rotary wing operations and the decrease in onboard deicing systems will essentially force advancements in icing forecast capability.

The final en route flight hazard that I want to address is lightning or electrostatic discharges. The interest in this phenomenon is essentially unique to the military, principally, the Air Force. Our use of naphtha-based fuel, our increasing reliance on sophisticated electronics for flying our aircraft and the shift to more and more composite aircraft structures has elevated the importance of this hazard to us blue-suiters. Our interest is somewhat different than that of the airlines, who for the most part take a lightning or electrostatic discharge as a matter-of-fact and press on with little or no effect, except for structural pitting. General aviation, of course, has a somewhat different viewpoint than the airlines. One thing of interest to me is that a few years back the Air Force Geophysics Lab proposed and built a prototype airborne lightning detector and went to our major air commands looking for customers. They found very little interest at that time, but the situation would probably be quite different today. Also, there is some pressure within the Air Force for us to develop a capability to issue mission-tailored lightning discharge probability forecasts. Quite frankly, I hope this does not become a firm forecast requirement. In this case, I firmly believe that an airborne system is the path to follow.

A few weeks ago some information crossed my desk which stated that the weather associated aircraft accident rate within the Air Force had declined for 1977. My immediate reaction was that our aviation weather support was responsible for this decrease. Unfortunately this turned out to be a figment of my imagination. In reality, the decrease in 1977 was a result of a decrease in the frequency of one of the major producers of aircraft accidents, the thunderstorm. The forecast reliability had not changed from the two previous years.

Why do we find ourselves in a state where our forecast reliability from year to year increases every so slightly or not at all? I think there are definite reasons for this state of affairs, and I'm sure many of the reasons are well known, if not already well documented. Over the past 20 to 25 years, there has been a technology surge beyond anyone's wildest imagination. We have come to a state where automation is taking over many of the functions once held in high esteem by the human. Centralization has developed to the point where a person can actually control the operation of a machine from a distance half way around the globe. In the Air Weather Service, we routinely provide analysis and forecast information to our units in the Pacific and Europe from the Global Weather Central at Offutt AFB, Nebraska. This centralization of the forecasting functions is in most cases driving the forecast accuracy down when compared to a mix of centrally prepared and locally prepared forecasts. This is especially true for local forecasts of short-term duration.

Centralization also leaves us with no backup. If we find that umbilical cord severed, we may find ourselves as helpless as a new born babe. Technology is marvelous when put in the proper perspective.

In the past, our dollars devoted to meteorology R&D has brought forth some improvements. We've developed and put into operation bigger and better analysis and forecast models. We have in operation various versions of a computerized flight plan model. We have developed and put into operation a communication network for collecting and disseminating weather information which is ten times better than previous versions. We have doubled, tripled, or quadrupled our data processing capability. As a vivid example, at the Air Force Global Weather Central, we have six computer systems, four of which are running at nearly full capacity approximately 90% of the time. We process some 125,000 surface observations daily, plus carloads of other data including satellite information, soundings, pilot reports, etc., and we still want more--we need more to do our job better. What I'm really trying to say is that our R&D monies in meteorology have bought us many engineering improvements and very few improvements in our basic knowledge and understanding of the atmosphere. I dare say that the imbalance is on the order of 90% engineering improvement and 10% basic knowledge improvement. This can be highlighted by the fact that we still don't know the total structure of a thunderstorm or the true state of the atmosphere, even on a small scale.

This brings me to that part of my talk where I want to provide you a prognosis for the future. Being the Commander of Air Weather Service, I should be an expert at forecasting the future, but we'll have to see how it goes. I hope my verification rate is better than climatology.

I see satellites as opening additional doors in the realm of atmospheric observations. Multichannel imagery and advanced atmospheric sounders will complement surface based observing networks to aid in the determination of the true state of the atmosphere. Continued participation by the nations involved in the World Meteorology Organization activities will hopefully result in further improvements in the worldwide data base.

I see considerable value in the emphasis being placed on the oceans. The effects of these huge bodies of water and the interface between their surfaces and the atmosphere are still not well accounted for in our analyses and forecasts.

The Aircraft to Satellite Data Relay (ASDAR) system will have a definite positive impact on a worldwide observing network. This near real-time data will provide data for a continual updating of the state of the atmosphere.

The dollar investment for meteorological services (including aviation) is on the rise within the Air Force. I don't know if this holds true for FAA and NOAA, but I do expect that we may see a similar trend in their budgets in the not too distance future.

What this all means is, yes, there are programs upcoming that will provide us with ever increasing amounts of data to portray the true state of the atmosphere and provide better support to aviation systems. The question that remains in my mind is will we know how to effectively use or apply that data? I doubt very seriously that we will unless we see some progress in R&D efforts aimed at advancements in the science of meteorology.

I offer you these concluding comments before surrendering the podium and departing.

Weather impacts on aviation systems are real and substantial. I can't state emphatically that the impacts are growing or decreasing, but I can say that the emphasis is shifting in many cases. The increased sophistication of our aviation systems doesn't necessarily eliminate the atmospheric impacts; old problems just assume new proportions.

Within the atmospheric sciences, technological advances have outstripped advances in underlying knowledge. This gap will continue to widen unless existing trends can be reversed. More R&D efforts addressing the many scientific deficiencies will be required. Our scientific deficiencies are being camouflaged by technological advances.

We must attempt to focus R&D monies on projects which address these scientific deficiencies. With no increase in our investment in basic scientific knowledge, the future is much in doubt in my mind. With this in mind, we have identified a number of research objectives that we hope AF HQ will find money to pursue.

Ladies and gentlemen, it has been my pleasure to spend this time with you this evening and offer you these comments. I look forward to seeing many of you in the future. I'm sure your workshop will be a smashing success. Thank you for your invitation.



**SECTION IV
TOPIC AREA
PRESENTATIONS**



**ORIGINAL PAGE IS
OF POOR QUALITY**

N79-17416

Severe Storms

John W. Connolly

U.S. Department of Commerce/NOAA

I am happy to see that my presentation comes under the heading of overview papers. As I look around this room and realize that a fair sampling of the severe storm experts in the country are sitting out there I will not presume to present anything more than an overview. At best, I can set the scene for the discussions that will follow.

The Glossary of Meteorology for 1959 in defining a severe storm says that it is "In general any destructive storm; but usually applied to severe local storms in particular, i.e., intense thunderstorms, hail storms and turbulence." I think I should like to broaden that definition slightly; however, I do agree that the thunderstorm may well be the principle villain among the severe storms that affect aviation.

I would like to start by outlining the severe storms that I believe pose some hazard or even significant inconvenience to aviation. Then I would like to look briefly at what is being done to overcome these undesirable characteristics of severe weather and finally perhaps leave a few thoughts that might be useful in the discussions of these two days.

Table 1 tabulates my list of severe storms and their impact on aviation. I'm sure it's not exhaustive and we could discuss it exhaustively. Let's not do that. Let's save that analysis for later on.

I have placed the thunderstorms and tornado at the bottom of my list not as indication of priority but because I will have more to say about them than the other storms.

So let's briefly mention hurricanes. Obviously, they have an on aviation. But these storms are usually pretty well identified over the oceans long before they make landfall. Their publicity value is such that their presence and track is well known even after landfall. Primarily, I put them in the category of severe storms that create a significant inconvenience to aviation. Of course, they are a hazardous storm that aviation should steer clear of. However, they do not figure prominently in National Transportation Safety Board (NTSB) accident statistics.

...PROCEEDING PAGE NUMBER NOT FILMED

TABLE 1

SEVERE STORMS
IMPACTING AVIATION

- Hurricane
 - Wind Damage
 - Coastal Flooding
 - Traffic Disruption

- Severe Winter Storm
 - Heavy Snow
 - Airport Closings
 - Traffic Disruption

- Severe Local Storm
 - Thunderstorm
 - Turbulence
 - Hail
 - Wind Shear
 - Tornado

Forecasts and warnings for these severe storms emanate primarily from three hurricane forecasts centers, the National Weather Service (NWS), National Hurricane Center (NHC) in Miami, Florida, the Eastern Pacific Hurricane Center, San Francisco, and the Central Pacific Hurricane Center, Honolulu. NHC in Miami delegates part of its warning responsibility to three Hurricane Warning Offices, Boston, Massachusetts, Washington, D.C., and San Juan, Puerto Rico. The basic products of these offices are tropical storm and hurricane advisories which are distributed to the general public, mass media, public officials, etc. These products are issued routinely every six hours as long as the storm is a threat.

When winter storms approach, meteorologists in Weather Service Forecast Offices (WSFOs) issue warnings of the expected hazardous weather for their areas of forecast responsibility. WSFOs coordinate with other WSFOs in their area and issue Storm Summaries to the news media. Local offices distribute warnings to the press, radio, TV, State Police, Defense Civil Preparedness Agency, etc.

Severe winter storms are not only a hazard, but a significant and sometimes catastrophic inconvenience. Two blizzards spaced a week apart combined forces in January of this year to virtually paralyze the eastern half of the nation, closing most airports for at least several hours and affecting the cancellation, diversion or delay of 5,000 commercial flights plus an untold number of other flights.

The first storm on January 20, primarily affected the East. All three New York airports were closed for 30 hours disrupting 1800-2000 operations. The second, more severe blizzard of January 26-27 hit the midwest. O'Hare Airport shut down for more than 22 hours on January 26. About 3,000 O'Hare flights were affected because high winds prevented snow removal. During the same two days Cleveland had a total of 28 arrivals and departures compared with the normal 200 per day.

United Airlines estimates that their loss alone will be in the millions of dollars in terms of snow removal, overtime, lost crew time and lost revenue. United was the biggest loser because of its high number of operations, the predominance of east-west routing and its reliance on Chicago and Cleveland as its two main hubs.

According to the Federal Coordinator for Meteorological Services and Supporting Research in his 1978 National Severe Local Storms Operations Plan, severe local storms are "Dangerous storms that usually cover relatively small geographical areas or move in narrow paths and are of sufficient intensity to threaten life and property. For the purpose of this plan, a severe local storm is a tornado,

funnel cloud, waterspout, or a thunderstorm with winds of 50 knots or greater and/or hail 3/4-inch in diameter or greater at the surface. Wind damage may be used to infer the occurrence/existence of a severe local storm."

The Federal Coordinator adds tornadoes, funnel clouds and waterspouts to the 1959 definition.

So I guess this is what we come down to, the severe storms that cause the greatest hazard to aviation are categorized as severe local storms. The remainder of what I am going to say then will relate to a large degree to thunderstorms and tornadoes.

The Severe Local Storms (SELS) Unit of the National Severe Storms Forecast Center (NSSFC) is responsible for issuing Tornado and Severe Thunderstorm Watches. SELS also issues Severe Weather Outlooks which indicates areas of greatest severe storm potential for periods up to 24 hours in advance.

Local NWS offices issue Tornado and Severe Thunderstorm Warnings based on radar indications and actual storm reports, and work closely with local officials in establishing and training storm spotter networks. Local offices issue statements to keep the public informed on weather developments.

Watch and warning information is relayed to the public by mass news disseminators and by the National Oceanic and Atmospheric Administration (NOAA) Weather Radio. The NOAA Weather Wire Service is the primary link between NWS and the news media. The Service A, Service C, and Radar Reporting and Warning Coordination (RAWARC) teletypewriter networks are other dissemination channels. Effective use is also made of the Defense Civil Preparedness Agency (DCPA), National Warning System (NAWAS) in the dissemination of warnings.

That's a broad overview of the NWS program for severe storms as they affect the general public. For aviation the Aviation Weather Services program provides aviation forecasts and warnings based in part on products from the National Hurricane Center and the National Severe Storms Forecast Center. In-Flight Advisories warn pilots of potentially hazardous weather. SIGMETs describe weather severe enough to concern all aircraft while AIRMETs describe weather of lesser severity affecting mainly small aircraft but possibly of concern to all aircraft. The Federal Aviation Administration (FAA) through the Air Route Traffic Control Centers (ARTCCs) but particularly through the Flight Service Stations (FSSs) is the prime disseminators of hazardous weather warnings to aircraft. Since no other industry is as interested in and affected by weather as aviation, it is essential that we gear our efforts in the severe storms area to aviation needs.

For the Air Force, the Air Weather Service provides both facsimile and teletype products, from its Air Force Global Weather Center, (AFGWC) on a world-wide basis to provide forecasts and warnings of severe weather which might affect Air Force operations.

Military Weather Advisories are issued by AFGWC in graphic teletype format and as a facsimile chart four times daily to provide guidance to field forecasters on tornadoes and thunderstorms.

Now, I would like to turn to what is going on in the area of severe local storms to be more responsive to the needs of the public but particularly to the needs of aviation.

Many of you know of the Joint Doppler Operations Program (JDOP) that is going on at the National Severe Storms Laboratory (NSSL) sponsored jointly by the NWS, AWS, NASA, FAA and the NOAA Environmental Research Laboratories (Table 2). Recognizing that the typical weather radar now in operation in the National Weather Radar Network measures only reflectivity, it has been realized that accurate and dependable diagnosis of damaging winds and tornadoes is not possible. Many investigators have long believed that Doppler radar will provide important new measurements needed to improve tornado and severe thunderstorm warnings.

The first operational experiment of this joint doppler project took place at NSSL in the Spring of 1977; its objective, real-time severe thunderstorm identification using Doppler radar. Obviously, the results of one test season are not conclusive. However, several preliminary conclusions were reached including the fact that severe weather probability of detection is higher with Doppler than with the conventional radar in the present warning system.

The project continues in 1978 with joint operations scheduled from April 15-June 15, 1978. The focus of the 1978 operational tests will be on improved detection and warning of tornadoes and damaging winds (Table 3). Particular attention will be given to evaluating Doppler data for improved warnings of hazards to aircraft in flight.

The Severe Storm Laboratory conducts a data gathering project each spring to meet certain research requirements in a broad program to further our knowledge of severe storms. The next major effort of this kind is scheduled for 1979, which leaves this spring, 1978, substantially free for the joint doppler tests. This allows for provision of significant aircraft operations in support of the tests.

TABLE 2

JOINT DOPPLER OPERATION PROJECT (JDOP)

Sponsored by:

- o National Weather Service
- o Federal Aviation Administration
- o National Oceanic and Atmospheric Administration

For:

- o Real-time severe thunderstorm identification
- o Improved tornado detection and warning
- o Improved warning of hazards to aircraft
- o Doppler radar

TABLE 3

FY 1978 JDOP OBJECTIVES - AVIATION

1. Correlate areas of lightning and turbulence.
2. Investigate shear-turbulent zones with VAD Doppler radar scans while aircraft measure turbulence and wind.
3. Describe gust fronts with Doppler radar, particularly under optically clear air conditions.
4. Determine the potential of Doppler radar for turbulence avoidance by using spectrum width real-time display for aircraft vectoring in thunderstorm areas.

Project "Rough Rider" is the ongoing project among the Air Force, NASA, FAA, and NSSL NOAA. Objectives of the 1978 program are:

- 1) Determine the potential of Doppler radar for turbulence avoidance in an operational system by using spectra with real-time display for aircraft vectoring in thunderstorm areas. This "real-time" simulation requires thunderstorm penetrations at altitudes similar to that in use by en route aircraft,
- 2) Investigate shear-turbulent zones with Doppler radar scans while aircraft measure turbulence and wind,
- 3) Correlate areas of lightning and storm hazards, and
- 4) Investigate gust front turbulence and wind structure by aircraft and Doppler radar particularly under optically "clear" air conditions.

In conjunction with this and in cooperation with several groups, NSSL is investigating thunderstorm gust front structure and the wind shears associated with convective activity. Specifically, in addition to completing the "en route" type of thunderstorm turbulence program, NSSL will be conducting gust front penetrations to determine horizontal and vertical winds and will run simulated approaches to Tinker AFB or other airfields within 200 km with suitable airfield facilities during gust front passages. Data from a 450 m instrumented tower and observations of gust fronts with Doppler radar will supplement the aircraft observations. Chaff will be used at times to enhance radar data from regions without precipitation.

The FAA has the major interest in the low level wind shear associated with severe storms. We are all aware that severe wind shear conditions occurring at low altitudes in the terminal area are hazardous to aircraft operations during takeoff, approach and landing, as indicated in a number of accidents in the past several years.

The overall objective of the Low-Level Wind Shear Program is to examine the hazards associated with wind shear in the terminal area, characterize the wind shear problem, establish required work needed to arrive at solutions; and implement and integrate such solutions into the National Airspace System (NAS).

The Wind Shear Program is designed to investigate solutions to terminal area wind shear hazards in three general categories: (1) through the use of ground-based equipment, (2) through the use of airborne equipment, and (3) by improving the accuracy of terminal area wind shear forecasting techniques. The program has been structured to provide near-term and interim products for operational application, when such products can provide a safety increase. Longer term program tasks will be integrated with the near term outputs as they become available.

For most major air terminals, the hazardous shear can seriously disrupt air operations on a scale from 10 minutes to several hours. Fortunately, strong shears occur relatively infrequently. The major terminals may experience strong wind shears in and around the approach and departure corridors up to about 50 hours per year. The reason that stronger wind shears are not more common is that the meteorological conditions that cause them are rare. These conditions, in their order of severity are:

Gust Fronts - Gust fronts are normally formed from mature, severe thunderstorms and when located in the vicinity of airports can be extremely hazardous to air traffic. A zone of maximum hazard precedes the radar echo and is not identified by current airport surveillance radars or adequately detected by today's airport weather sensors. Only on very rare occasions has it been located and tracked by weather radar (Figure 1).

Frontal Zones- The second mechanism capable of causing strong wind shears are frontal zones. These zones are routinely identified by conventional meteorological analysis but identification of the shear associated with them is much more difficult. Today's wind measuring system does not provide accurate measurement of the types of winds that cause hazardous shear for the altitudes at which aircraft operations are most seriously affected.

Low-Level Temperature Inversion- The last general meteorological condition that creates wind shear hazards, and perhaps the rarest of all, is the condition where a low-level temperature inversion forms near the surface with a warmer, low-level wind of considerable magnitude, immediately on top of the inversion. This situation typically occurs after midnight.

To summarize, hazardous low-level wind shear can be generally characterized as a rare event that is not easily identified or tracked. It occurs year round, and when it is detected it is normally after the fact, by past event analysis or through the pilot reporting system.

One of the nearer term solutions being investigated by the FAA is the Low-Level Wind Shear Alert System (LLWAS) (Figure 2). Arrays of anemometers are being installed at six airports throughout the U.S. to collect data on the effectiveness of this system concept in detecting the passage of thunderstorm gust fronts.

In this system, the outputs from each anemometer are compared with centerfield sensor. When a significant difference is noted between the centerfield and any other anemometer an alert is sounded in the tower cab.

VERTICAL CROSS SECTION OF A THUNDERSTORM

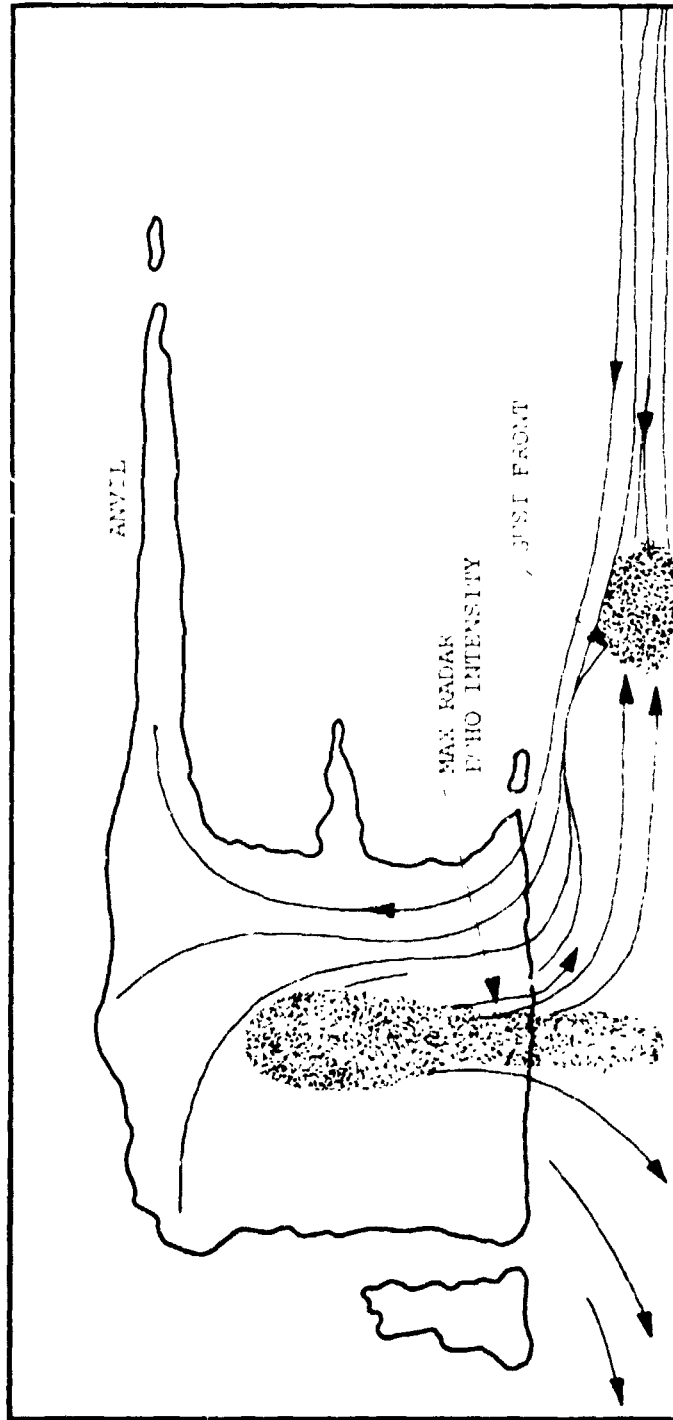

Figure 1

MAXIMUM RADAR ZONES

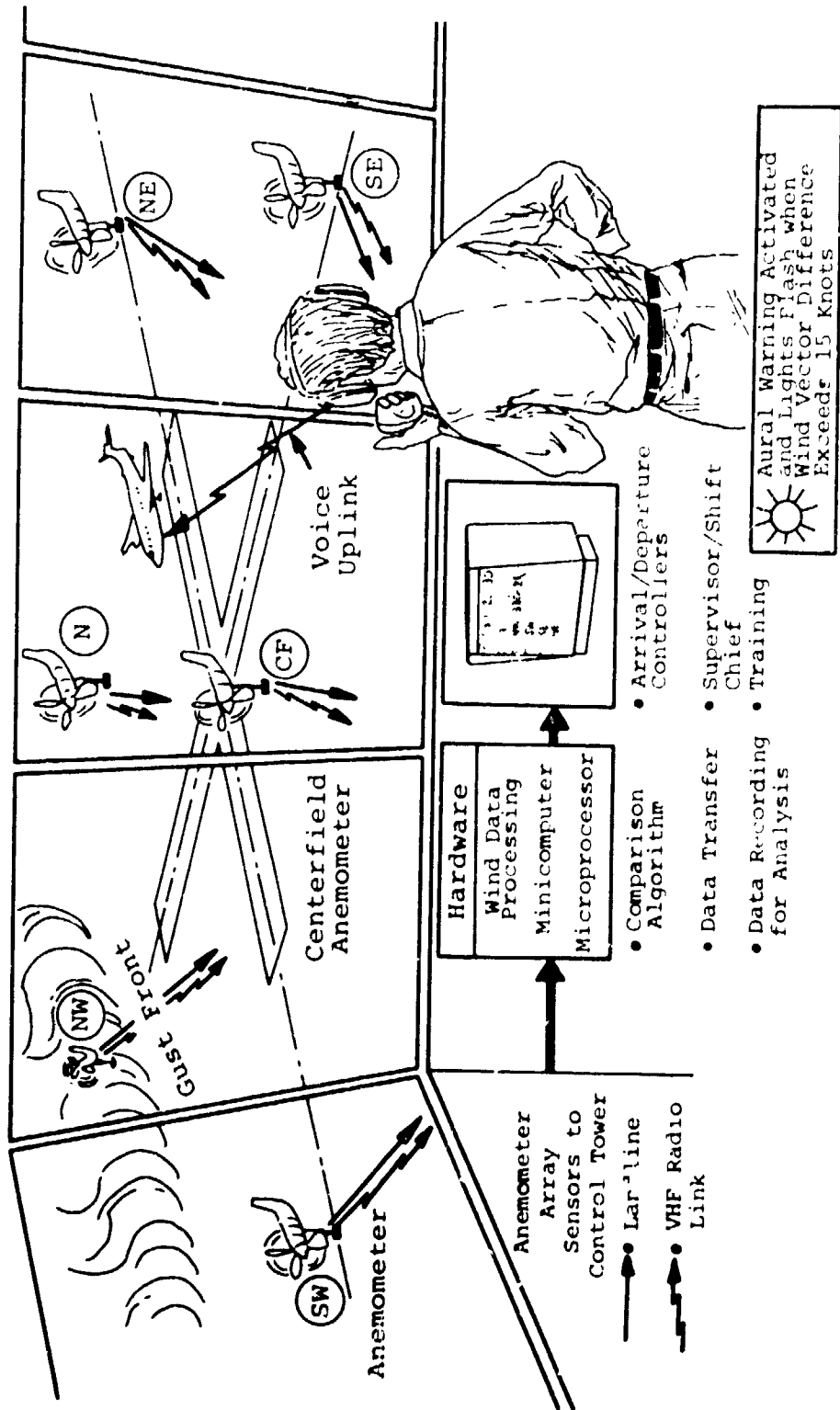

Figure 2 Low Level Wind Shear Alert System Concept

Data collected at these six airports during the Spring/Summer of 1977 are being used in conjunction with experimental test results from the National Aviation Facilities Experimental Center (NAFEC) to determine the threshold levels required for declaration of a hazardous horizontal wind shear and to verify the number and locations of anemometers required for reliable detection of a thunderstorm gust front. The basic design of the tower cab test display and the needed information for operational language tests have been determined. The test site at NAFEC is configured to permit evaluations of various types of anemometers and determine numbers and locations of anemometers required at an airport.

The airports selected for the test program are:

1. Tampa International, Florida
2. William B. Hartsfield International, Atlanta, Georgia
3. Houston Intercontinental, Texas
4. Stapleton International, Denver, Colorado
5. Will Rogers World, Oklahoma City, Oklahoma
6. John F. Kennedy International, New York
7. NAFEC, Atlantic City, New Jersey

Implementation of anemometer arrays at a larger number of airports will be predicated on the success achieved during the test program.

One of the major research efforts in the NWS Techniques Development Laboratory (TDL) is to develop automated techniques for forecasting severe local convective weather, notably thunderstorms and their manifestations like hail, strong wind gusts, and tornadoes. The forecasts cover three time ranges: 12-48 hr (medium range), 2-6 hr (short range), and 0-2 hr (very short range). These areas are dealt with in three distinct tasks.

In the area of medium-range forecasting, TDL has developed new multiple regression equations to predict the probability of both general and severe thunderstorms for the March 16 to September 15 convective season. In the case of severe thunderstorms, different equations were developed for the spring (March 16 to June 15) and summer (June 16-September 15) seasons. The predictand for the severe storm equations was based on authenticated reports for tornadoes, large hail, or damaging winds obtained from the National Severe Storms Forecast Center (NSSFC). The thunderstorm predictant consisted of manually digitized radar (MDR) data which were collected from hourly teletypewriter reports and archived on magnetic tape. MDR data are coded for blocks 40-45 n mi (75-80 km) on a side, located in the East and Midwest; they provide a significant increase in resolution and a much larger data sample than were available for previous studies. Both the echo intensity and coverage within each block are digitized.

Thunderstorm and severe storm probabilities are forecast for each block in the MDR grid array. Probability forecasts are valid for the 12-36 hr interval following 0000 GMT initial time. In addition, thunderstorm probabilities are also forecast for the 12-24, 24-36, and 36-48 hr projections following initial data time. The forecasts are transmitted by facsimile and KCRT to field offices of NWS, including NSSFC in Kansas City.

In the 2-6 hr prediction effort, TDL has developed and implemented improved prediction equations for thunderstorms and severe local storm probabilities. In addition, the area over which the probabilities are issued has been enlarged. Otherwise, this season's operational system is unchanged from that of the 1977 season. Four 2-6 hr forecasts are issued daily for the periods 1700-2100, 2000-0000, 2300-0300, and 0200-0500 GMT. Individual probabilities are valid for square areas 40-45 n mi (~75-80 km) on a side, in the case of thunderstorms, and about 85 n mi (~160 km) on a side in the case of severe storms. Forecasts are transmitted to NSSFC and NWS forecast offices by teletype bulletin.

Figure 3 is a sample thunderstorm probability forecast. The solid lines are isopleths of thunderstorm probability for 10% intervals. Actual occurrences of thunderstorms during the valid period are indicated by T's. Radar data, used to define thunderstorm events, were missing within the area delineated by dotted lines.

Effort in the very short range (0-2 hr) relies on the capability of weather radar to identify and trace the development of severe local storms. The problem is: (1) to identify echo characteristics and parameters related to severe weather events, (2) to develop automated methods of forecasting the movement and development of these echoes, (3) to develop statements on the probability of convective weather in selected areas within predetermined time intervals, and (4) to implement results obtained into the operational environment of NWS. Products from these studies should prove extremely useful in providing timely warnings to the general public and to special users, such as the aviation industry.

I believe that it is in the short and very short range time frames that we should collectively concentrate our efforts. Significant improvements in the 0-2 hour forecasts hold great promise for aviation.

Operationally there are two major efforts underway within the NWS and FAA to provide more nearly real-time hazardous weather information to the pilot. The first involved assignment of meteorologists to the FAA ARTCCs and the second is the centralized convective SIGMET program.

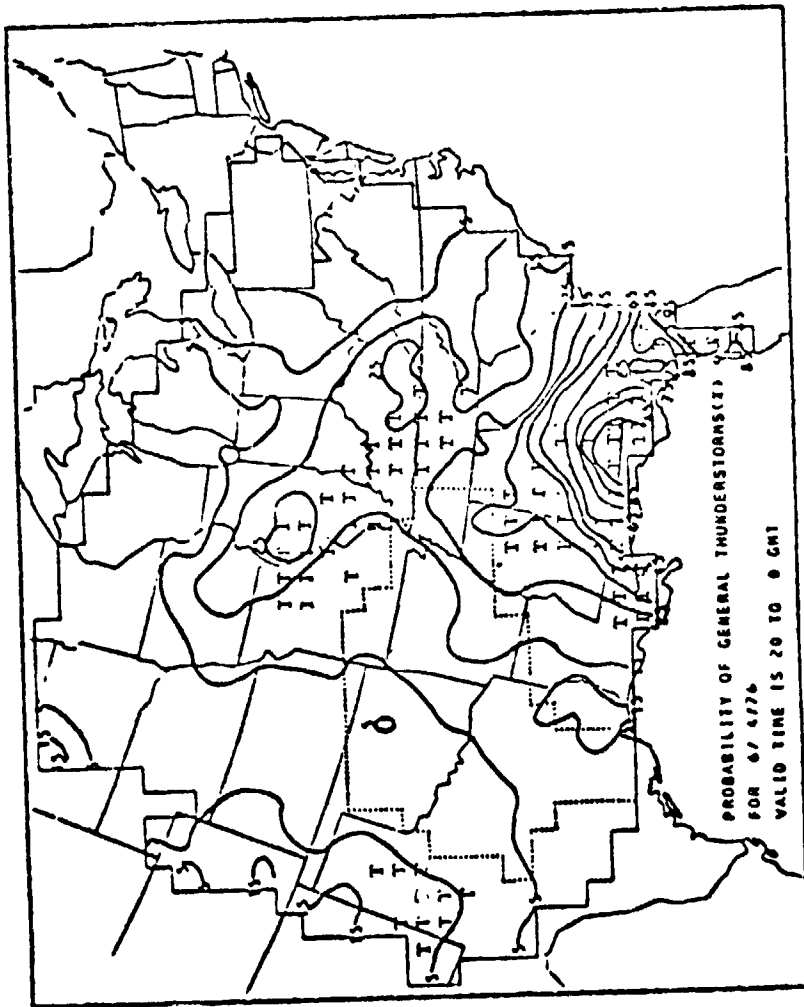

PROBABILITY OF GENERAL THUNDERSTORMS

Figure 3

On April 3, 1978, meteorologists will report for duty in 13 ARTCCs (Figure 4). On April 17, they will begin two shift per day operation. This will be the culmination of many months of effort on the part of the FAA and NWS. ARTCCs involved are Atlanta, Houston, Chicago, Indianapolis, Cleveland, Washington, Boston, Fort Worth, Jacksonville, Memphis, New York, Kansas City and Miami. We expect that meteorologists will be assigned to the remaining seven continental ARTCCs during FY-79 depending upon resource availability.

These "Center Weather Service Units" (CWSUs), as they are called, will be staffed with three meteorologists.

The CWSU meteorologists will monitor aviation weather conditions within the area of responsibility of the ARTCC to which each unit is assigned and will keep the weather coordinator and flow controller appraised of changing weather conditions. Particular emphasis will be applied to those situations which would be hazardous to aviation safety and impede the flow of air traffic in the National Airspace System (NAS).

The meteorologists will provide consultation and advice to senior level air traffic controllers concerning forecast or actual adverse weather conditions which affect air traffic operations or aircraft safety over any portion of the ARTCC area, including terminals. They will provide detailed briefings of current and forecast weather several times a day with particular emphasis on hazardous weather associated with severe storms.

To assist in this responsibility, the CWSU will be equipped with remote facsimile readouts of NWS radars, satellite pictures, weather teletype, facsimile weather charts and a Plan View Display (PVD) similar to the scope used by the controller. The PVD provides a unique capability to request pilot reports (PIREPs) from specific aircraft to confirm the existence of forecast weather conditions.

The second program, to be instituted on May 2, 1978, is the convective SIGMET program. In an attempt to provide the pilot more timely information on hazardous weather the NWS will consolidate all convective SIGMETs at the National Severe Storms Forecast Center (NSSFC) at Kansas City. Based on NWS radar observations, NSSFC will issue hourly and special convective SIGMETs for the conterminous United States. Each SIGMET will cover approximately 1/3 of the United States (Table 4). They will be issued in two parts. Part A will be a plain language SIGMET relating the convective phenomena to en route VORs. It will be suitable for direct broadcast by air traffic controllers.

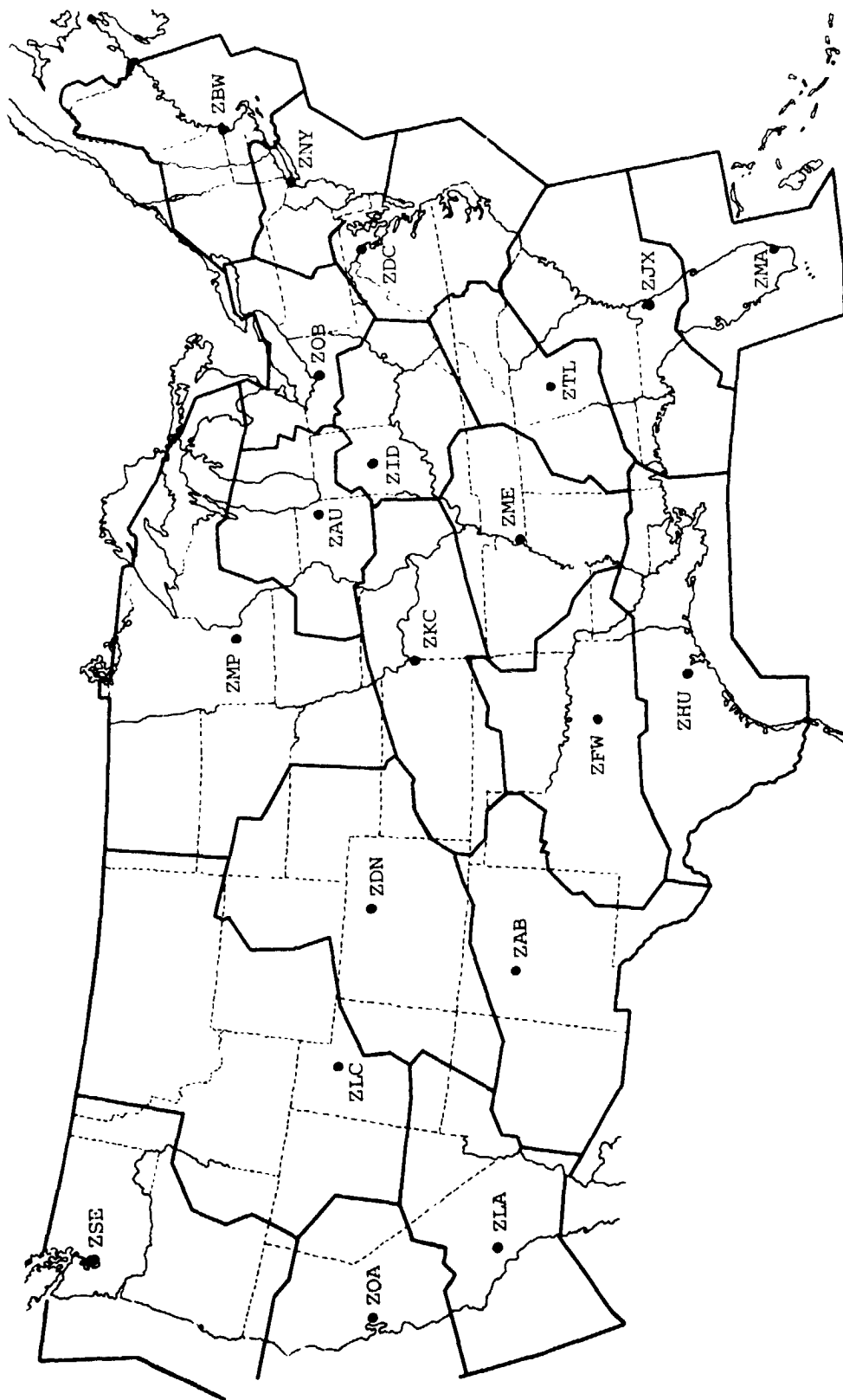

Figure 4
ARTCC BOUNDARIES

TABLE 4

CONVECTIVE SIGMET REPORTS

MKCC WST 221835
CONVECTIVE SIGMET 19
KS OK
FROM 30E GCK TO 20E GAG.
LN BKN TSTMS 25 WIDE MOVG 2515 WITH AN INTS-LVL5 CELL.
TOPS TO 450...HAIL TO 1 IN...WIND GUSTS TO 55.

LN BKN TSTMS 25 WIDE DFW 340300 DFW 335250
MOVG 2515 TOPS 450
CELL LVL5 DIAM 10 DFW 330280 MOVG 2120

CONVECTIVE SIGMET 20
ND SD
FROM RAP TO 90W MOT TO PMB TO 40N MHE.
AREA SLD TSTMS WITH FEW EMBDD CELLS MOVG FROM 2530
WITH A FEW INTS-LVL5 AND EXTRM-LVL6 CELLS.
TORNADO RPTD 1820Z VCNTY GFK. MAX TOPS TO
450...HAIL TO 1 IN...WIND GUSTS TO 55.

AREA BKN TSTMS FSD 290240 FSD 310400
FSD 350270 FSD 310080 MOVG 2530 TOPS 450
CELL LVL6 DIAM 20 FSD 300210 MOVG 2515 TOPS 420
CELL LVL5 DIAM 10 FSD 330200 MOVG 2515 TOPS 420

Part B will provide an additional level of detail and will require a special plotting chart primarily for use in the cockpit. The convective phenomena will be related in azimuth and distance from six plotting points spaced throughout the United States. It is intended to provide the pilot a means of updating the weather along his route of flight and to provide him sufficient advance information to allow for early route deviation if necessary. Several aviation groups will evaluate the plotting chart beginning May 2.

We expect that these two new programs, the ARTCC Weather Service Unit and the centralized convective SIGMET program will make a very significant improvement in the availability of aviation weather information in the National Airspace System. Thus, I believe that the potential for providing near real-time information to the pilot on hazardous weather associated with severe storms has never been greater.

This paper is not intended to be a comprehensive compendium of all the activity going on in this important area of meteorology and aviation safety. Obviously, it is not. Significant research is going on in several agencies concerning many aspects of severe storm impacts on aviation.

For example, I have hardly mentioned the lightning hazard work of NASA, or the radar scope interpretation for severe thunderstorms and tornadoes by the Air Force, or the FAA work in remoting NWS weather radars in the Atlanta Center, or the many other severe storm activities at NSSL.

NOAA's Wave Propagation Laboratory is working with FAA to design a network of pressure jump sensors to detect thunderstorm gust fronts. A test network is currently installed at Dulles and tests have been conducted at O'Hare.

NASA is doing work on numerical modelling to obtain information on the structure and mechanism of the gust front phenomena.

There are many other programs underway within the civil and military agencies which will make a contribution.

But, if I were to list some of the critical things that need to be done, so that the hazards of severe storms might impact the airspace system less than they do now, I would include:

1. Provide real time or near real-time hazardous weather information to the pilot.

2. Provide real-time weather radar information to the controller.
3. Significantly improve the 0-2 hr aviation weather forecast.
4. Provide more surface weather observations as input to the (0-2 hr) forecast program.
5. Accelerate development of automatic weather stations to provide these observations.
6. Challenge aviation meteorologists to predict the occurrence, intensity and position of gust fronts.
7. Concentrate on the detection and forecasting of Clear Air Turbulence (CAT).

But above all, demand that the FAA and NOAA establish an integrated Aviation Weather System for the National Airspace System.

This concludes my overview on severe storms. I hope that not only by what it includes but by what it omits as well, it may serve as a stimulus for discussions during the next two days.

N79-17417

Atmospheric Disturbance Modelling Requirements

For Flying Qualities Applications

David J. Moorhouse

Air Force Flight Dynamics Laboratory

ORIGINAL PAGE IS
OF POOR QUALITY

Introduction

Reference 1 contains several papers that discuss different requirements for meteorological information for use in different aspects of aircraft design and operation. It was mentioned many times that the requirements are dependent on the application. This paper will discuss yet another application—flying qualities.

First, flying qualities and the influences of atmospheric disturbances will be discussed. Aircraft flying qualities are a compromise between requirements for stability on one hand and for maneuverability on the other hand. Although this trade-off is not simple it is a far more complex problem to insure good flying qualities in atmospheric disturbances—turbulence, gusts and wind shear. In reality, the range of atmospheric disturbance possibilities is infinite. For flying qualities applications, therefore, the major concern is to represent the characteristics which have a primary effect on aircraft response and pilot control. The best engineering model is the simplest one that satisfies this goal. U.S. Military aircraft flying qualities requirements are contained in MIL-F-8785B "Military Specification—Flying Qualities of Piloted Airplanes," (Reference 2). An atmospheric disturbance model in this document forms the main connection between flying qualities and atmospheric disturbances. An extensive revision effort is currently being finalized and next, therefore, the current revisions to the atmospheric disturbance section of MIL-F-8785B will be reviewed. Finally the state of the art will be briefly discussed with the author's opinions on remaining deficiencies and areas for future research.

Flying Qualities

It is appropriate first to define what is meant by flying qualities, in order to keep the whole discussion in perspective. A definition from Reference 3 is "those airplane characteristics which govern the ease or precision with which the pilot can accomplish the mission." Flying qualities are "measured" by subjective pilot opinion according to a rating scale (Reference 3) which is presented in Figure 1 for illustration, but will not be discussed further here. Note, however, that flying qualities are tied to accomplishing a specific task and must include consideration of environmental conditions. An airplane can have characteristics that make the task of landing relatively easy in calm air. The same task becomes very demanding or even impossible in a violent thunderstorm, even though the airplane characteristics may not have changed. A consideration of atmospheric disturbances is implicit in any analysis of flying qualities.

It is of interest to note that the first report issued by the National Advisory Committee on Aeronautics (Reference 4) was concerned with airplane response to gusts. We also know that the Wright Brothers designed their first flying machine to be marginally stable or unstable to minimize the response to gusts. The Wright Flyer only flew with continuous pilot inputs, for which sufficient control was provided. Previous experimenters had been plagued by insufficient control to correct the large responses of a very stable configuration. The problem under consideration is therefore as old as flying.

For the purposes of the flying qualities specification an engineering model of atmospheric disturbances is required. This engineering model may be considered as the simplest or minimum acceptable model which correctly identifies the primary parameters of particular interest. It is then hoped that secondary parameters do not alter the results, and tertiary parameters are not recognized. This is in contrast to the objectives of basic research into meteorological phenomena or the physics of atmospheric dynamics. It is also noted that terminology has different connotations depending on an individual's background or field of endeavor. To prevent any confusion, certain terms are defined for use in interpreting the current revision to MIL-F-8785B, Reference 5.

Mean Wind

This is the steady wind or the reference value on which perturbations are superimposed. The mean wind could vary with time and spatial coordinates, but it is considered to be horizontal and only a function of altitude. Since for engineering purposes the mean wind is constant with time, the meteorological concept of "averaging time" does not apply.

There is no requirement for the "mean wind" to actually be a mean over any particular time period. A mean wind has an effect on flying qualities only at low speeds, primarily in landing. The trim condition, power setting and angle of attack to maintain a given glideslope in a headwind or tailwind, and bank angle or sideslip for a crosswind, are functions of the wind speed. The effect on flying qualities may or may not be significant, but will depend on the specific configuration.

Wind Shear

This is the rate of change of the magnitude of the mean wind with altitude, a restricted interpretation for this particular application. The influences of wind shear have been shown by many investigators (e.g. References 6,7, and 8). The analysis of the total effect of wind shear on pilot control or flying qualities is very complex. As an example, Reference 9 reports results of a piloted, ground-based simulation of landing in wind shear. Two runs of one configuration in the same wind shear profile produced completely opposite results. On one run the pilot landing without difficulty, on the other run the result was a "crash." Thus even in a controlled experiment the problem of recognition, perhaps pilot distraction by a side task, is apparent.

It is a common, unusually valid assumption to consider that the longitudinal dynamics of a conventional aircraft have two normal modes, a short period and a phugoid. The short period is a well-damped oscillation of angle of attack, α , and pitch attitude, θ ; the phugoid is a much slower, lightly-damped oscillation of θ and airspeed, u . Now, if we consider a "simple shear" there is a perturbation if the flight path is not horizontal, the response is as shown in Figure 2. An increase in headwind (decrease in tailwind) produces an increase in airspeed and an immediate increase in lift. The initial response is a rise above the glideslope and an indicated increase in airspeed. The "natural" control action is to pitch down and reduce power. Without any control input, the longer-term response is to stabilize to the original airspeed and acquire a steeper flight path. The long-term effect requires an increase in power, i.e., opposite to the initial transient. Thus in a continually changing wind, constant shear, a pilot may be correcting the initial transient until, if the shear ends, the airplane is grossly off the required steady-state conditions. If the shear due to a reducing tail wind ends close to the ground, then a short landing could result (Reference 1a). This problem is even worse if a coupled approach is made with planned transition to manual control in dynamic conditions (Reference 10). This reference also discusses the implications of pilot control of the initial transient. The pitching response to elevator input, governed by the

short-period dynamics, is typically an order of magnitude quicker than airspeed response. Tight control of pitch attitude is equivalent to suppressing θ in the phugoid; this gives an aperiodic response (e.g., see Reference 11). When this aperiodic response is compared with the uncontrolled phugoid, as illustrated in Figure 3, it is seen that there will be an apparent loss in airspeed stability to the pilot. This analysis is supported by results of a computer simulation of the DC-10 shown in Figure 4, taken from Reference 12.

Whereas in the uncontrolled case the airspeed oscillates around the nominal value, pilot control of the glideslope causes the airspeed to diverge much more and, more important, the divergence subsides very gradually. The implication is that tight control of pitch attitude to correct flight path perturbations due to wind shear may lead to over-control of the airspeed perturbations. MIL-F-8785B does contain requirements for the uncontrolled phugoid. We now see that the effect of atmospheric disturbances and the resulting pilot actions can produce a completely different response.

Vector Shear:

This is the rate of change of the direction of the mean wind with altitude. Statistically this phenomenon has a low probability of occurrence, although it can be produced by certain topographical features. Flight tests at Wright-Patterson AFB, for instance, frequently show vector shear. It is proposed as a useful device for simulation purposes to disturb all the degrees of freedom of airplane motion.

Turbulence

This term is used to denote the continuous, random fluctuations in wind velocity which must be described statistically. Turbulence is commonly assumed to be random with a zero mean and a normal, or Gaussian, distribution. Actual measurements of atmospheric turbulence have shown it to be non-Gaussian, containing more small and large disturbances than a Gaussian distribution. The most significant point to be made here is that the atmospheric disturbance model to be used, for instance in a piloted ground-based simulation, should be consistent with the objectives of the simulation and the fidelity of the total system representation. Thus turbulence is generally included in a simulation only to add to the piloting task. The pilot is evaluating the task of flying the airplane and the fine detail of the turbulence is unimportant, within reason. The influence of turbulence, however, is dependent on the task the pilot is trying to perform. In normal cruise, the airplane can be allowed to just fly through light turbulence, whereas in landing approach tighter control of the flight path is obviously required.

In piloted simulations where Gaussian turbulence is the only disturbance, the normal complaint is that Gaussian disturbances are too regular. A disturbance in one direction is followed by one in the other direction, alleviating the need for pilot control. Part of the solution may be to instruct the pilot to perform the task as aggressively as possible, and part of the solution may be an improved disturbance model. Non-Gaussian turbulence is not necessarily the answer, the author of Reference 13 expresses the opinion that if three items are handled more realistically, then non-stationarity aspects may not be important. The three items are (i) the use of excessive intensity values, (ii) the use of excessive (i.e. high altitude) integral scale values and (iii) the use of inappropriate forcing inputs due to the gusts. (All are covered by the proposed revisions detailed in the next section). Non-Gaussian turbulence models have been developed, however their use in simulations has yielded mixed results. For the study reported in Reference 14 the pilot chose a non-Gaussian turbulence for an evaluation of the landing approach task of STOL aircraft. Reference 15 showed no conclusive results in an attempt to develop the same non-Gaussian model. There are also a variety of approaches to developing a non-Gaussian representation, as discussed in Reference 5. It can safely be stated, therefore, that there is no unanimous opinion with respect to any departure from a Gaussian distribution of disturbances. In fact, the atmosphere itself does not have a uniquely non-Gaussian characteristic. Using the fourth-order moment as a measure of non-Gaussianity Reference 16 indicates a wide range of values about Gaussian.

Gust

This term is used to denote a discrete or deterministic change in the wind velocity. In application gusts may be used independently or superimposed on a mean wind and/or turbulence to represent large disturbances. Used appropriately a gust can actually represent a discrete wind shear such as can occur at a temperature inversion; vertical air movements such as downdrafts or thermals; the large (3 σ or 4 σ) fluctuations that occur in actual turbulence but which are not represented in the assumed Gaussian form of turbulence: the fluctuations due to the wake of man-made or topological features; or an independent discrete phenomenon such as the wing tip vortex of another aircraft. The gust is used to ensure sufficient control to recover from large disturbances- an essential part of flying qualities.

The above definitions depart from meteorological practice in order to allow some flexibility in defining models of atmospheric disturbances that are tractable for engineering analyses. Although the desirability of tractability should be obvious, the requirement for flexibility is considered to be equally desirable. During the course of an aircraft development a variety of analyses, computer simulations,

piloted simulations, etc. are performed with different objectives and different requirements for atmospheric disturbance inputs. The definitions given earlier attempt to identify and separate the primary parameters in atmospheric disturbances which relate to aircraft control and flying qualities. The synergistic effects of any or all of these parameters can and should be obtained.

A final comment is required in this section. The definition of flying qualities given earlier addresses only open-loop (i.e., no control inputs) airplane characteristics and this is essentially the content of MIL-F-8785B. Hopefully the preceding discussion indicates that, in reality, flying qualities is a much broader problem than just a consideration of airplane characteristics. In the Flight Dynamics Laboratory's Flying Qualities Group, we are moving towards what may be called "handling qualities- those characteristics of the total system that govern the ease or precision with which the pilot can accomplish the mission." Characteristics of the total system include airplane characteristics, which may be modified or augmented by the flight control system, pilot interaction with the flight control system and the display, operational procedures and the influences of environmental conditions that are being discussed at this workshop.

Rationale for the Current Revision of MIL-F-8785B

MIL-F-8785B states that the atmospheric disturbance models shall be used to assess:

- a. The effect of turbulence on the flying qualities of the airplane;
- b. The ability of a pilot to recover from the effects of discrete gusts.

There were no criteria, however, to judge the acceptability of any effects of turbulence on flying qualities. Remembering Figure 1, there are three levels of flying qualities which could depend on the stability and control/response characteristics of the airplane and the operation or failures of the flight control system. Although there is no exact correspondence between the different levels of flying qualities as affected by aircraft characteristics and the effects of turbulence, there is a similarity in principle. It is now proposed to define three intensities of atmospheric disturbance and to recognize the degradation of pilot rating that occurs with increasing turbulence. The different atmospheric disturbance values are denoted "light" (probability 10^{-1}), "moderate" (probability 10^{-3}) and "severe" (probability 10^{-5}). The proposed revision paragraph is:

1.5 Levels of flying qualities

Where possible, the requirements of section 3 have been stated in terms of three values of the stability or control parameter being specified. Each value is a minimum condition to meet one of three levels of acceptability related to the ability to complete the operational mission for which the airplane is designed. The levels are:

ATMOSPHERIC DISTURBANCES

LIGHT	MODERATE	SEVERE
Level 1 Flying qualities adequate for the mission Flight Phase	Flying qualities adequate to accomplish the mission Flight Phase, but some increase in pilot workload or degradation in mission effectiveness, or both, exists	Flying qualities such that the airplane can be controlled safely, but pilot workload is excessive or mission effectiveness is inadequate, or both. Category A Flight Phase can be terminated safely, and Category B and C Flight Phases can be completed.
Level 2 Flying qualities adequate to accomplish the mission Flight Phase, but some increases in pilot workload or degradation in mission effectiveness or both, exists	Flying qualities such that the airplane can be controlled safely, but pilot workload is excessive or mission effectiveness is inadequate or both. Category A Flight Phases can be terminated safely, and Category B and C Flight Phases can be completed.	Flying qualities such that control may be maintained long enough to fly out of the disturbance.

LIGHT

MODERATE

SEVERE

Level 3

Flying qualities such that the airplane can be controlled safely, but pilot workload is excessive or mission effectiveness is inadequate or both, Category A Flight Phase can be terminated safely, and Category B, and C Flight Phases can be completed.

Flying qualities such that control can be maintained long enough to fly out of the disturbance.

No requirement

Note: Category A are non-terminal Flight Phases requiring rapid maneuvering or precision tracking, such as air-to-air combat. Category B are non-terminal Flight Phases using gradual maneuvers and with precise tracking, such as climb. Category C are terminal maneuvers, such as takeoff and landing.

Thus, the light disturbances should not increase pilot workload significantly and therefore should not degrade the pilot opinion relative to calm air. "Pilot opinion" here is considered in the total sense of performing a given task with a particular aircraft system in a certain atmospheric environment. The atmospheric disturbances are a part of the task and increasing the intensity of the atmospheric disturbances increases the pilot workload, or alternatively decreases pilot performance, in carrying out the task. Pilot opinion, whether the result of flight test, piloted simulation or analytical prediction, is affected by aircraft characteristics and by the intensity of atmospheric disturbances. The pilot opinion, workload or performance corresponding to basic (i.e., calm air) characteristics of Level 1, 2 or 3 should not degrade out of that Level in light disturbances. Successive degradation will be allowed in moderate and severe disturbances. For the normal aircraft state (no failures-Level 1 flying qualities) it is proposed that moderate and severe disturbances may cause degradations equivalent to Level 2 and 3 flying qualities. There is currently insufficient data to define the progressive degradations of increasing disturbances and inadequate basic characteristics. It is now necessary to recognize characteristics worse than the "Level 3" currently defined in MIL-F-8785B. With a degraded aircraft state in severe disturbances, which correspond to typical thunderstorm activity, the minimum requirement would be that control of

the aircraft can be maintained, for instance landings could not necessarily be completed whereas a wave-off could. The effect of this proposal is to replace an implicit dependence with an explicit definition of the effects of atmospheric disturbances.

Turbulence becomes less and less continuous in the statistical sense as the intensity increases, but can be expected to occur more in patches. The severe disturbance can therefore be used to show that control is sufficient "to fly out of a patch". Information on the lengths of patches of turbulence is lacking, however, it should be noted that the conditions favoring the development of turbulence normally extend over areas measured on a synoptic scale and that as a consequence turbulence patches cluster both in time and in space. This makes it difficult for instance to estimate the distance that has to be covered on the average before turbulence of a given reference intensity will be met, but it defines the proportion of all air mileage, or of all time, containing turbulence of a given reference intensity. The probabilities tentatively chosen for the light, moderate and severe atmospheric disturbances are 10^{-1} , 10^{-3} and 10^{-5} , respectively. As pointed out, however, the numerical values are necessarily global average and bear no relationship to any particular flight. When considering terminal operations, for example, the probable winds vary from airfield to airfield. The atmospheric disturbance model is at best an imprecise average, justifying some engineering approximations as discussed in the preceding section.

One critical atmospheric phenomenon that was omitted from MIL-F-8785B was wind and associated shears. A wind shear at altitude can be adequately represented by a discrete gust, however it was felt that some more fundamental representation was required to cover operation in the earth's boundary layer. For the specification two altitude regions are considered—a low altitude region from the ground to about 2000 ft and a medium/high altitude region about or above 2000 ft. The boundary between the two regions is not rigid but is more a function of the flight phase being considered. For the low altitude region a logarithmic wind profile with altitude is specified and the revision to MIL-F-8785B also directs the consideration of wind vector shear, i.e. changes in wind direction with altitude.

Atmospheric stability has significant influence on the wind and turbulence characteristics (as detailed in Reference 1b). The logarithmic wind profile specified herein is applicable to a neutral or slightly unstable atmosphere. The data presented in Figure 5 indicates that this is consistent with surface wind speeds greater than approximately 10 kts. Higher wind speeds enhance the atmospheric mixing and support the near neutral stability. Figure 5 also shows the near neutral stability (i.e., defined as categories C & D in the figure)

and hence, by implication, the wind profile proposed for the revision to MIL-F-8785B occurs with approximately 55% probability. The mathematically inclined readers will immediately realize from the preceding discussion that the proposed revision apparently neglects atmospheric conditions with a total probability of occurrence of about 45%. What is especially unfortunate is that these less probable atmospheric conditions probably cause more than their fair share of aircraft accidents and should not be neglected.

Unstable conditions caused by the onset of strong surface heating are normally associated with light wind speeds. These conditions often cause significant fluctuations in wind direction and produce thermals, depending on the terrain. Changes in wind direction with altitude are believed to be of sufficient importance that they are suggested in the proposed revision, even though the probability of occurrence is less in neutral stability. Phenomena such as thermals can be adequately represented as discrete gusts.

Stable atmospheric conditions are often associated with strong temperature inversions. A strong inversion has the ability to make conditions above and below it independent of each other. There is the possibility of significant changes in wind speed and/or direction across the inversion. Again this type of disturbance can conveniently be represented by discrete gusts.

Thus the simplifications to produce the proposed disturbance model were done without neglecting any flying qualities implications of stable or unstable conditions, etc. The model is not necessarily self-consistent but, to reiterate, is intended to show the influences of a range of disturbance features on airplane flying qualities. The proposed medium/high altitude model is essentially the same as MIL-F-8785B, with either the Dryden or the von Karman frequency spectrum for isotropic turbulence to be used. The three levels of turbulence intensity are given in Figure 6 as simplified functions of altitude. The "1-cosine discrete gust" is retained although half the cycle is specified, i.e.

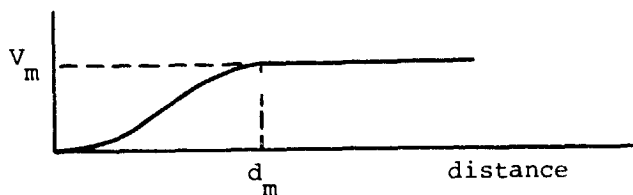

Now the return half of the gust does not have to follow immediately after the original perturbation, nor do the two halves necessarily have to be equal. The same procedure is used for calculating the gusts viz. several values of d_m are chosen to correspond to the natural modes of the airframe and flight^m control system (not the structural modes) and the magnitudes are obtained from Figure 7 using the appropriate turbulence intensity.

A separate model is proposed for low altitudes, representing the major change to MIL-F-8785B. A mean wind profile as a function of height above ground level is defined by

$$u_w = U_{20} \frac{\ln (h/Z_0)}{\ln (20/Z_0)}$$

where u_w = mean wind speed

h = height above ground

Z_0 = surface roughness height

= 0.15 for terminal Flight Phases

= 2.0 for other Flight Phases, such as terrain following

The wind speed at 20 ft. above the ground, U_{20} , is given in Figure 8 as a function of probability of occurrence. The values to be used for the different levels of atmospheric disturbance are indicated.

Different orientations of the mean wind relative to the runway for terminal Flight Phases or the aircraft flight path for other Flight Phases are to be considered. In addition, changes in direction of the mean wind speed with altitude are to be considered as given in Table 1, using the most critical altitude and wind orientation.

Table 1. Vector Shear

intensity	$\Delta\psi_w$ degs	Δh feet
LIGHT	0	--
MODERATE	90	600
SEVERE	90	300

The maximum values of crosswind and tailwind components at 20 ft above the runway are given so that this requirement is consistent with operational considerations.

The low altitude turbulence intensities to be used are $\sigma = 0.1 U_{20}$, with σ_u and σ_v given by Figure 9 as functions of altitude. The appropriate scale lengths are given in Figure 10 as functions of altitude. (Both these last two figures are from Reference 1b). The same procedure is to be used for calculating the low-altitude discrete gusts, with the exception that the specification will direct the use of both single and double ramps. A single ramp in the appropriate axis would appear as a scalar wind shear. Of particular note is that the proposed revisions will require that the turbulence velocity components shall be along axes aligned with the mean wind. Thus, u_g is the longitudinal velocity perturbation in the direction of the mean wind, with v_g and w_g being the transverse components. For application in analyses or piloted simulation the specified turbulence intensities require transformation to aircraft body axes.

The logarithmic wind profile is suggested rather than a specific shear value as being more representative of real-world winds. In addition, Reference 17 presents simulation results that show landing touchdown point to be more sensitive to logarithmic shear than to linear shear. Figure 11 (taken from Reference 17) shows the effects of a given initial wind at 500 ft shearing to zero at the runway. Although the study was done for an automatic landing system, the results are taken to be indicative of piloting difficulty.

It should be emphasized that the proposals contained in this section are currently going through a government/industry review cycle. In this process, comments are solicited from potential users before the specification is formally amended. Chalk of Calspan recommends an alternate method for considering the influences of turbulence on flying qualities (Reference 18). The low-altitude portion of the proposed model has been used in a Flight Dynamics Laboratory simulation of the YC-15, unpublished. The comments by the pilots were favorable; but the task was to evaluate the airplane not the disturbance model, per se.

State of the Art

As already stated, atmospheric disturbances have been studied since flying began. A great deal of work has been done in the meantime; as an example, Reference 13 lists a further 269 references. A consideration of the state of the art will necessarily be brief in this paper, concentrating on the flying qualities aspects. The Flight Dynamics Laboratory has sponsored turbulence research in the

past, the most notable of which is probably the series of Critical Atmospheric Turbulence (CAT) Programs (References 20 through 25). These programs measured atmospheric turbulence characteristics in various altitude ranges. An interim model and requirements for the TOLCAT program were defined in Reference 26.

More specifically directed towards the piloting problems, two contracts with Northrop Corporation investigated "Flying Qualities in Turbulence" (References 27 and 28). A follow-on contract with Rockwell Corporation investigated the interaction of structural modes with pilot control of response to turbulence (Reference 29). These efforts developed a pilot model for control of the perturbations due to continuous turbulence. Although this research contributed to our understanding of pilot control, no attempt was made to develop the turbulence model.

Support was provided for initial development of the non-stationary turbulence model of Reeves (Reference 30). In simple terms, it proposed multiplying two uncorrelated Gaussian white noise processes and using an appropriate filter to tailor the frequency spectrum. This version of the model was tested in Reference 14, with encouraging results. The model was further developed in a form to allow control of the fourth-order moment as a measure of the patchiness but yielded inconclusive results (Reference 15).

The University of Toronto conducted a wind tunnel study of turbulence characteristics on a landing glideslope (Reference 31). In a specially modified wind tunnel, approximately 1,000 ft of atmospheric boundary layer can be simulated with independent control of velocity profile and turbulence intensity. A large number of correlation measurements of the turbulent velocity components were completed with hotwire probes in the scaled atmospheric boundary layer. The majority of these measurements were confined to a mean velocity power law variation with the index, $n = 0.16$ and a glide-slope angle of 15° . Limited data were also taken with glideslopes of 45° and 90° and some with $n = 0.35$. With two probes at different points on the glideslope, all the terms in the correlation matrix were obtained for different ratios of wind speed to approach speed. The scatter in the state vector elements due to turbulence was predicted for the landing approach of a typical STOL aircraft.

Reference 1c discussed the requirement for a standardized turbulence model and pointed to MIL-F-8785B as a starting point. In a sense, the disturbance section of MIL-F-8785B is presented as a minimum acceptable model with which to validate the flying qualities of a particular aircraft configuration. It is recognized that more sophisticated models exist and, of course, would be more than acceptable. As such, it is suggested that Reference 1b forms a better starting point for winds and turbulence,

and may be considered state of the art. Since this model is well documented it will not be discussed here, except to say that it contains a "classical" representation of turbulence. An alternate approach, which must be considered in any assessment of the state of the art, is due to Jones of RAE (see e.g. References 32-34).

The essence of Jones' proposals is provided by a direct quote from Reference 32: "...the proposals made here concentrate on reproducing the probability distributions of the transition functions, or two-point velocity differences...". The two-point velocity differences are discrete values and the proposed model consists of a spectrum of discrete ramp gusts having a wide range of gradient distances, and intensities proportional to the cube root of the gradient distance. By means of appropriate filtering the power spectrum is adjusted to be consistent with the von Karman spectrum, except at low frequencies. This model can therefore be considered as a link between the use of simple discrete gusts and power spectral methods.

The family of discrete gusts is obtained by defining $N_{h,w} dH$ as the number of discrete ramp gusts per unit distance, in the length range $(H, H + dH)$ and having intensity greater than w . Then

$$N_{h,w} = \frac{k_1}{H^2} \exp \frac{-w}{k_3 H^{1/3}}$$

defines a family of discrete gusts with a wide range of lengths. In practice, for a particular aircraft mode the gusts of significance to the aircraft response have lengths within a limited range-centered on the 'tuned gust length' of that mode. This model seeks to define those gusts which contribute to the peaks in aircraft response. It is ideally suited to the single axis analysis of an aircraft flying under some constraint, such as discussed earlier and illustrated in Reference 34. New aircraft with advanced flight control systems may have multiple modes of response. A generalized turbulence model requires a wide spectrum of discrete gusts. A multiple-axis representation with the correct cross-correlations is still being developed and evaluated, but does offer the potential of unifying continuous turbulence and discrete gust analyses. This model is proposed for revision of the British flying qualities specification, as detailed in Reference 19.

Although this paper has emphasized simplification and identification of primary effects, this is not to suggest that further research is not needed. It is believed that a standard model is required and should be as complete as possible. It should include other effects such as visibility, precipitation, etc. An essential part of the documentation

for such a standard model would be a back-up report such as Reference 35 for MIL-F-8785B. In addition to substantiating data, this report should also include the degree of confidence in particular requirements, guidance for application or simplification of the model, alternate approaches, consideration of different applications, etc. That is, a "user's manual" is required in addition to the meteorological model of atmospheric dynamics. The model would form a common reference which could be tailored to specific applications.

Some additional research would be required to support such a standardized universal disturbance model. More information is needed on the patchiness of turbulence. Figure 6 shows the RMS turbulence intensity decreasing with increasing altitude at the higher altitudes. This trend may be driven more by the probability of encountering turbulence, rather than the intensity of turbulence encountered. More information is needed on how turbulence patches cluster in both time and space, especially for non-storm conditions. A weak point in the current turbulence model of MIL-F-8785B is the aircraft rotational disturbances. The pitching, rolling and yawing disturbances are derived from the linear gradients of turbulent velocities at a point and are accurate only at low frequencies. In a flying qualities simulation, it is quite common to increase or decrease parameters such as the rotational disturbances until the pilot accepts them as being "reasonable." Even if the mathematical model is accurate the simulator motion drive or visual system may produce extraneous effects which need to be tuned out. If we are to achieve a universal model, however, we must obtain the information to define the spatial variation of turbulent velocities. A fruitful area of research could be low-altitude flight measurements along typical glideslopes as well as at constant altitude. Ideally, measurements should be taken at more than one point along the flight path and at a number of transverse points. Assuming that the measurements are accurate enough to permit resolution into the correct axes, these results could be used to validate measurements taken in wind tunnels (e.g. Reference 31).

The basis for some of the simplifications in the proposed model is to identify typical aircraft responses. A discrete gust was assumed to be equivalent to the effects of certain atmospheric phenomena, such as inversions, gust fronts, wind shear, etc. The application of these effects in the design process is on a probability basis. More research is required to define the probability of occurrence of these unusual atmospheric phenomena. Also a better definition of the phenomena themselves, such as the potential wind difference across a temperature inversion, would lend additional credibility to the model. Again, the disturbance model in MIL-F-8785B is intended for use in aircraft design and development to minimize sensitivity to disturbances, ensure

adequate control, etc. A major factor in accidents has been pilot recognition of the severity of disturbances. One approach to alleviating this problem is pilot training in a variety of simulated disturbance conditions. A requirement does exist to obtain models for specific phenomena, to incorporate in the recommended universal atmospheric model.

A recommendation to develop a national, reference environmental model is easy to make, but it is recognized to be a monumental and probably thankless task. This can be illustrated by some results of a recent survey of users of the flying qualities specification, MIL-F-8785B (Reference 36). The document was evaluated as a firm specification (48% yes vs 52% no); a design guide (91% yes vs 9% no); and as test and evaluation criteria (87% yes vs 13% no). In addition, it is too restrictive (56% yes vs 44% no) and too lenient (32% yes vs 68% no). With respect to a universal environmental model, the optimum product will be achieved when nobody likes it but everybody uses it.

Conclusions and Recommendations

This paper has reviewed some atmospheric disturbance modelling requirements for aircraft flying qualities applications. It is concluded that some simplifications are justified in identifying the primary influences on aircraft responses and pilot control. Because of these simplifications the disturbance model in MIL-F-8785B, "Military Specification-Flying Qualities of Piloted Airplanes" does not represent the state of the art. It is recommended that a "universal" environmental model be developed, which could form the reference for different applications. This reference model should include the latest information on winds, turbulence, gusts, visibility, icing, precipitation. A significant number of models exist for probably all the required components. The first step would be to collect these models and choose "the best". The chosen model would be kept by a national agency and updated regularly by feedback from users. As already discussed, a user's manual is believed to be an essential part of such a universal model.

REFERENCES

1. Proceedings of the First Annual Workshop on Meteorological Inputs to Aviation Systems, Editors D.W. Camp and W. Frost, NASA CP-2028/FAA-RD 77-173, March 1977.
 - a. Melvin, W.W., "Problems Pilots Face Involving Wind Shear."
 - b. Schaeffer, D.R., "Wind Models for Flight Simulator Certification of Landing and Approach Guidance and Control Systems."
 - c. Kurkowski, R.L., "Summary Report of the Simulation Committee."
2. Anon., "Military Specification-Flying Qualities of Piloted Airplanes," MIL-F-8785B, August 1969.
3. Cooper, G.E., and Harper, R.P., Jr., "The Use of Pilot Rating Scale in the Evaluation of Aircraft Handling Qualities," NASA TN D-5153, April, 1969.
4. Hunsaker, J.C., "Report on Behavior of Aeroplanes in Gusts. Part I-Experimental Analysis of Inherent Longitudinal Stability for a Typical Biplane", Wilson, E.B., "Part II-Theory of an Airplane Encountering Gusts", National Advisory Committee for Aeronautics, Report 1, 1915.
5. Anon, "Proposals for Revising MIL-F-8785B, Flying Qualities of Piloted Airplanes," AFFDL/FGC Working Paper, Wright-Patterson AFB, February 1978.
6. Etkin, B., "Effect of Wind Gradient on Glide and Climb", J. Aero Sci., Vol. 14, No. 6, 1947, pp 365-368.
7. Frost, W., and Hutto, E., "The Influence of Wind Shear on Aerodynamic Coefficients", Proceedings of the 6th Conference on Aerospace and Aeronautical Meteorology, El Paso, Texas, November 1974.
8. Sherman, W.L., "A Theoretical Analysis of Airplane Longitudinal Stability and Control as Affected by Wind Shear", NASA TN D-8496, July 1977.
9. Hoh, R.H. and Jewell, W.F., "Investigation of the Vulnerability of Powered Lift STOL's to Wind Shear," Systems Technology, Inc. TR No. 1063-1, June 1976.

10. Moorhouse, D.J., "A Note on Wind Shear and Flying Qualities, with a Procedure to Warn of Adverse Conditions", AFFDL-TM-77-44, May 1977.
11. Newmark, S., "Problems of Longitudinal Stability below Minimum Drag Speed, and Theory of Stability Under Constraint", ARC R&M No. 2983, July 1953.
12. DeWulf, G.M., Harris, R.B. and Kressly, A.E., "The Effect of Wind Shear on a Jet Transport During Takeoff and Landing", Douglas Aircraft Co.
13. Houbolt, J.C., "Survey on Effect of Surface Winds on Aircraft Design and Operation and Recommendations for Needed Wind Research", NASA CR-2360, December 1973.
14. Moorhouse, D.J., and Jenkins, M.W.M., "Statistical Analysis of Pilot Control During a Simulation of STOL Landing Approaches," AIAA Paper 73-182, January 1973.
15. Reeves, P.M., and Campbell, G.S., Ganzer, V.M. and Joppa, R.C., "Development and Application of a Non-Gaussian Atmospheric Turbulence Model for use in Flight Simulators," NASA CR-2451, September 1974.
16. Rosenblatt, M and Van Atta, C., "Statistical Models and Turbulence," Lecture Notes in Physics, Springer Verlag, 1972.
17. Denaro, R.P., "The Effects of Wind Shear on Automatic Landing", AFFDL-TR-77-14, April 1977.
18. Chald, C.R., et al, "Revisions to MIL-F-8785B (ASG) Proposed by Cornell Aeronautical Laboratory under Contract F33615-71-C-1254," AFFDL-TR-72-41, April 1973.
19. Bennett, G., Squadron Leader RAF, "Revised Requirements for the Flying Qualities of Service Aeroplanes," Tech. Memo Structures 863, Royal Aircraft Establishment, April 1975.
20. Gault, J.D., "Low Altitude Atmospheric Turbulence LO-LOCAT Mid-Term Technical Data Analysis," SEG-TR-67-35, August 1967.
21. Crooks, M., Hobbit, F.M., and Prophet, D.T., "Project HICAT an Investigation of high Altitude Clear Air Turbulence", AFFDL-TR-67-123, November 1967.

22. Bowne, N.E. and Anderson, G.E., "Take-off and Landing Critical Atmospheric Turbulence (TOLCAT) Analytical Investigation", AFFDL-TR-68-23, April, 1968.
23. Gunter, E.D., Jones, W.G. and Monson, R.K., "Low Altitude Atmospheric Turbulence LO-LOCAT Phases I and II," AFFDL-TR-69-12, February 1969.
24. Elderkin, C.E., Powell, D.C., Dunbar, A.G. and Horst, T.W., "Take-off and Landing Critical Atmospheric Turbulence (TOLCAT) Experimental Investigation," AFFDL-TR-70-117, May 1971.
25. Elderkin, C.E., Powell, D.C., Dunbar, A.G. and Horst, T.W., "Take-off and Landing Critical Atmospheric Turbulence (TOLCAT) Experiments and Analysis". AFFDL-TR-71-172, April 1972.
26. Skelton, G.B., "Investigation of the Effects of Gusts on V/STOL Craft in Transition and Hover", AFFDL-TR-68-85, October 1968.
27. Onstott, E.D., and Salmon, E.P., "Airplane Flying Qualities in Turbulence", AFFDL-TR-70-143, February 1971.
28. Onstott, E.D., Salmon, E.P., and McCormick, R.L., "Prediction and Evaluation of Flying Qualities in Turbulence," AFFDL-TR-71-162, February 1972.
29. Crother, C.A., Gabelman, B. and Langton, D., "Structural Mode Effects on Flying Qualities in Turbulence", AFFDL-TR-73-88, August 1973.
30. Reeves, P.M., "Gamma-Gaussian Turbulence Simulation", AFFDL-TR-69-67, November 1969.
31. Reid, L.D., Etkin, B., Teunissen, H.W. and Hughes, P.C., "A Laboratory Investigation into Flight Path Perturbations During Steep Descents of V/STOL Aircraft", AFFDL-TR-76-84, August 1976.
32. Jones, J.G., and Tomlinson, B.N., "The Representation of Low Altitude Atmospheric Turbulence in Piloted Ground-Based Simulations", RAE TR 71198, September 1971.
33. Jones, J.G., "A Unified Discrete Gust and Power Spectrum Treatment of Atmospheric Turbulence", RAES International Conference on Atmospheric Turbulence, May 1971.

34. Jones, J.G., "Turbulence Models for the Assessment of Handling Qualities during Take-off and Landing", AGARD Meeting on Handling Qualities Criteria, AFARD-CP-106, June 1972.
35. Chalk, C.R. et al, "Background Information and User Guide for MIL-F-8785B (ASG), Military Specification-Flying Qualities of Piloted Airplanes", AFFDL-TR-69-72, August 1969.
36. Rediess, H.A., and Shafer, M.F., "Results of Subcommittee D Survey on the Future of Research of Flying Qualities and Criteria for Highly Augmented Aircraft", presented to SAE Aerospace Control and Guidance Systems Committee, Fort Walton Beach, FL, October 1977.

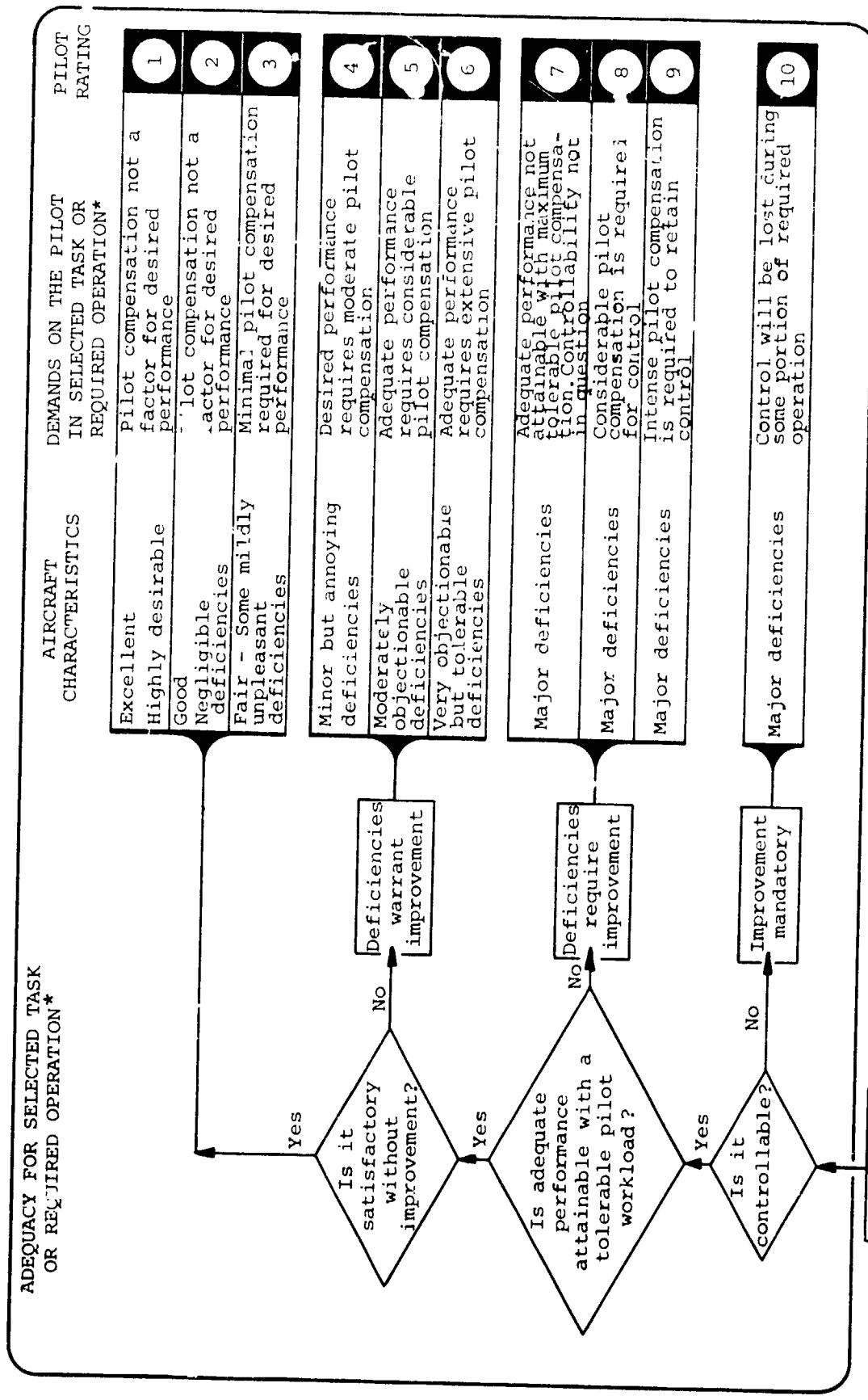

*Definition of required operation involves designation of flight phase and/or subphases with accompanying conditions.

Figure 1 Pilot Rating Scale

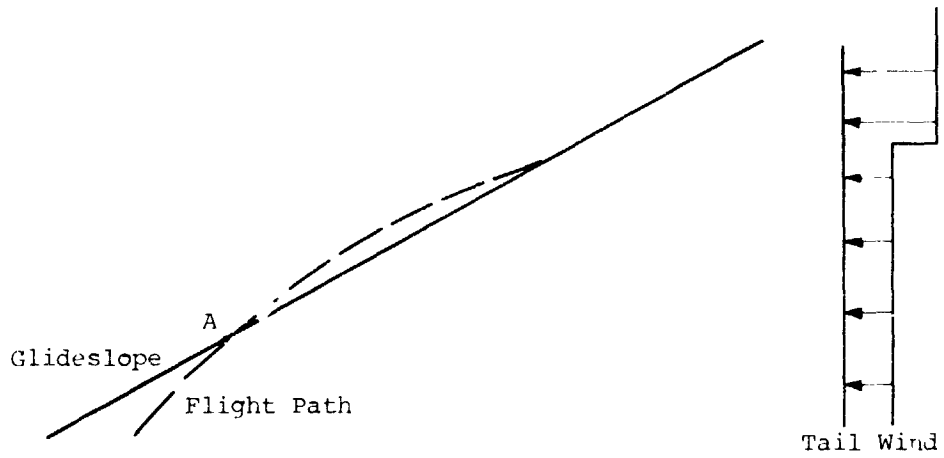

Figure 2 Sketch of Response to Wind Shear

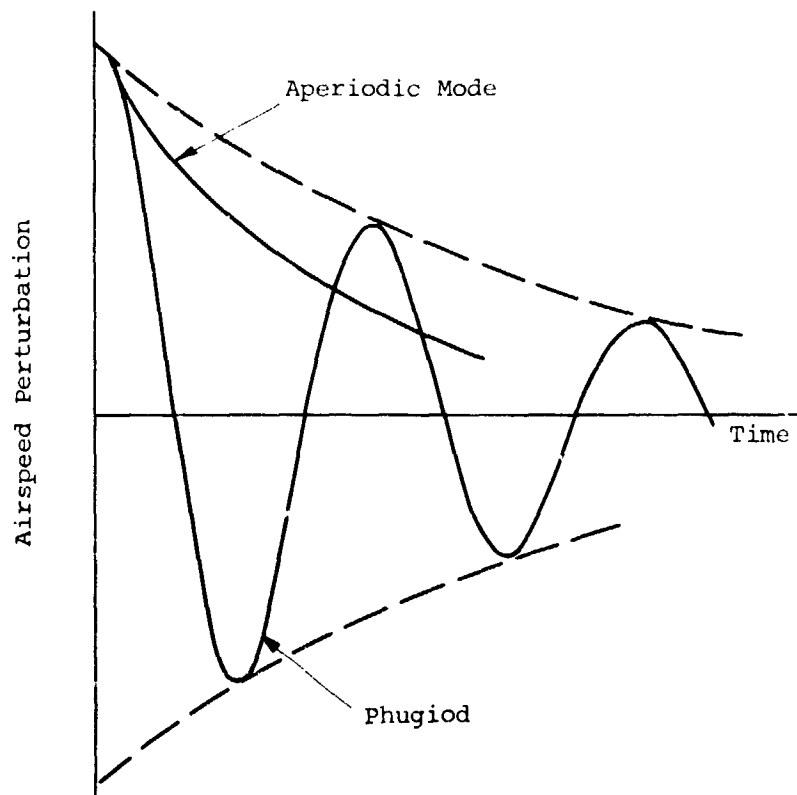
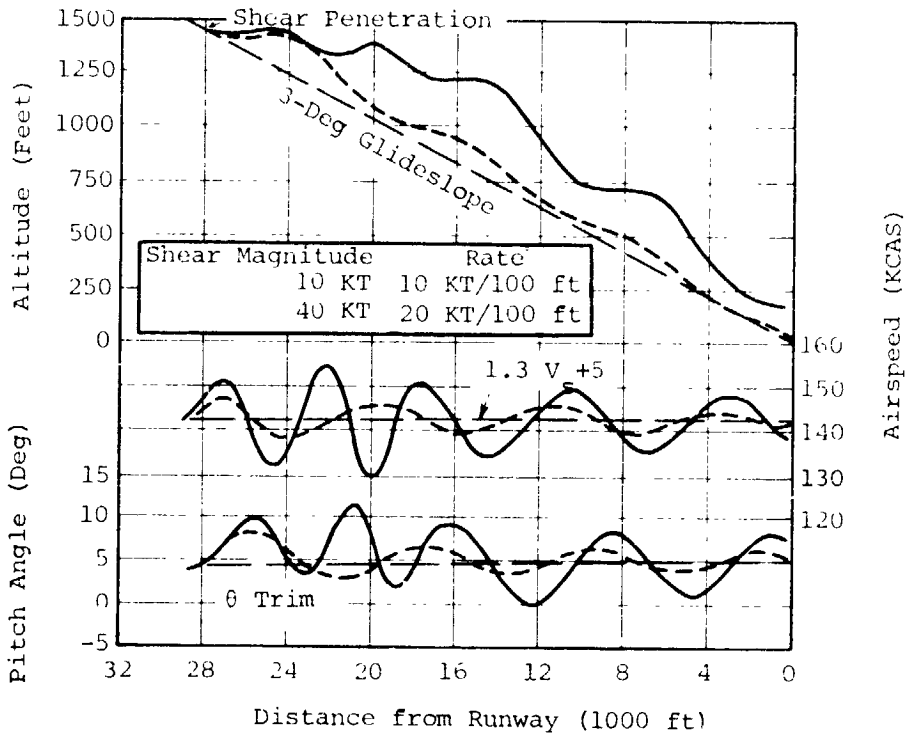

Figure 3 Comparison of Aperiodic Airspeed Mode With Uncontrolled Phugoid Response

Approach -- No Control Inputs
 Tail-to-Head Wind Shear
 Constant Thrust



Approach -- Pilot Controlled
 Tail-to-Head Wind Shear
 Constant Thrust

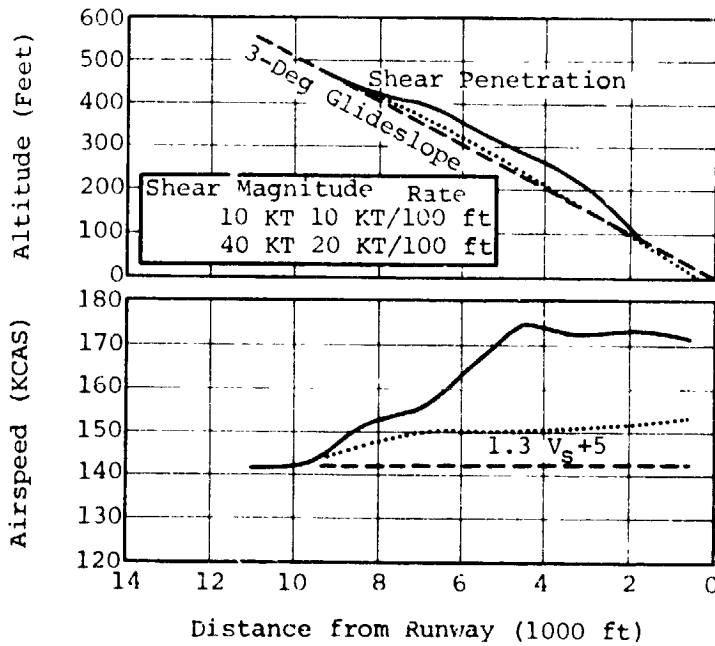

Figure 4 Effect of Control of Glideslope on Response to Wind Shear

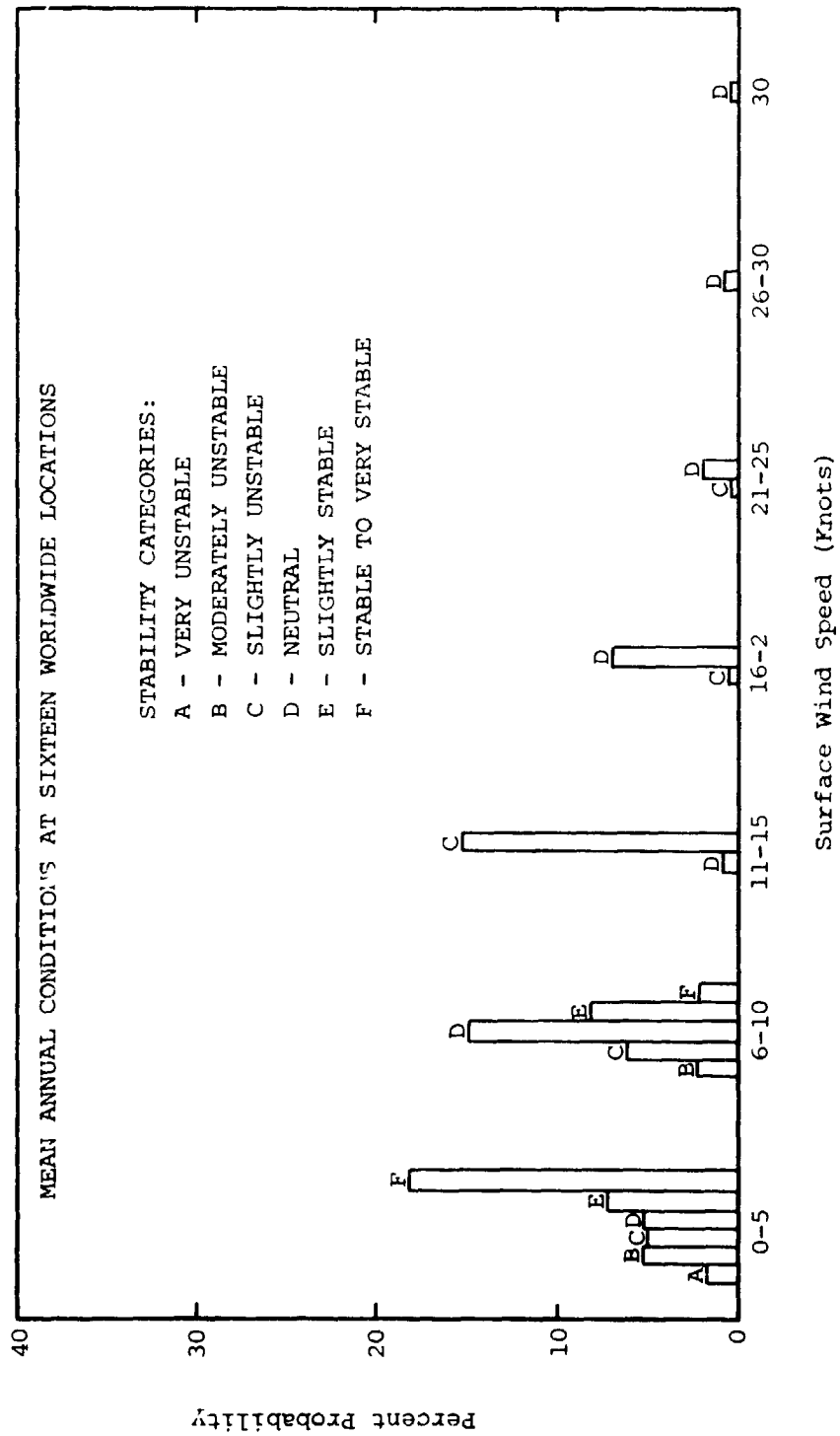

Figure 5 Joint Percent Probabilities of Surface Wind Speed and Stability Categories

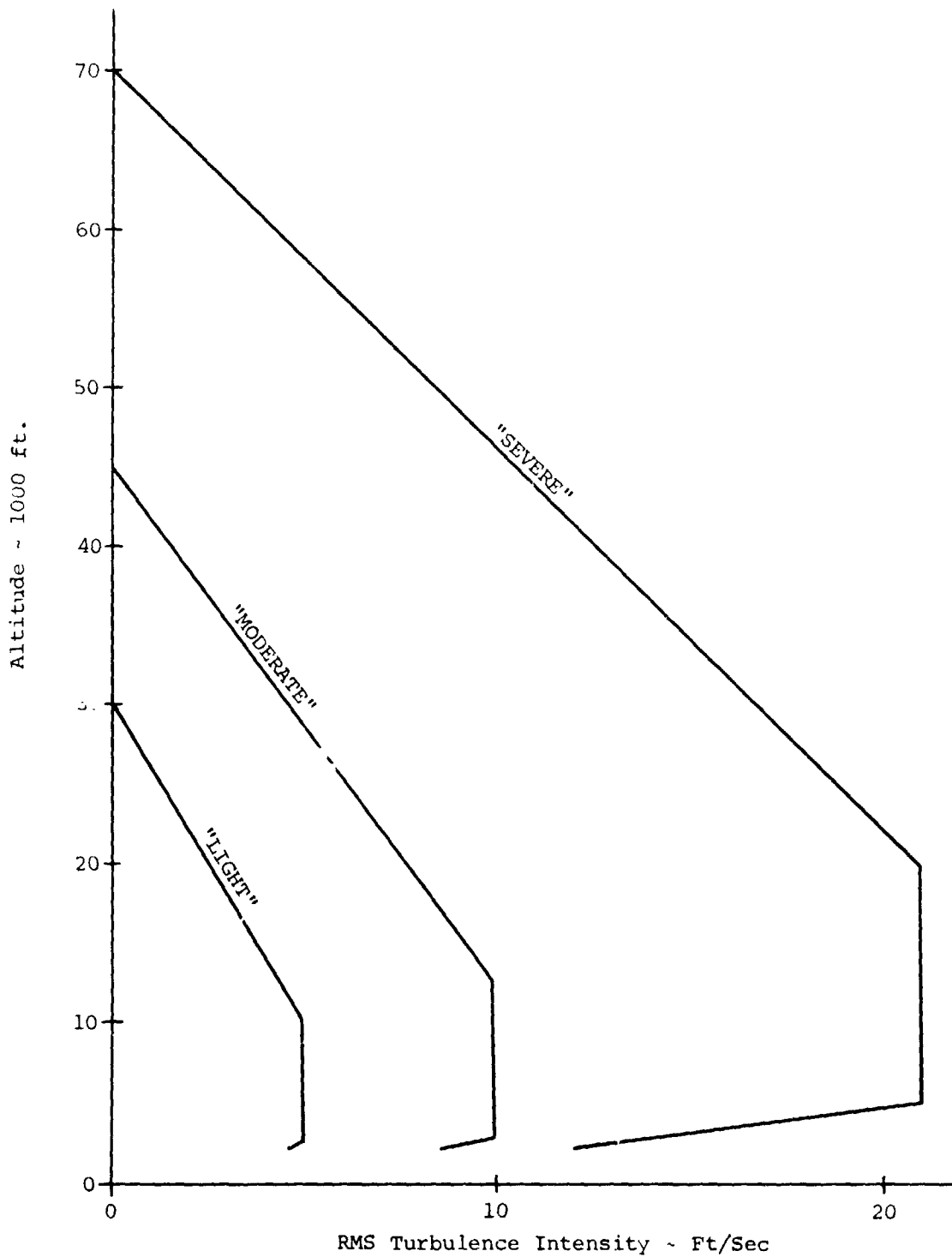

Figure 6 Med/High Altitude Turbulence Intensity

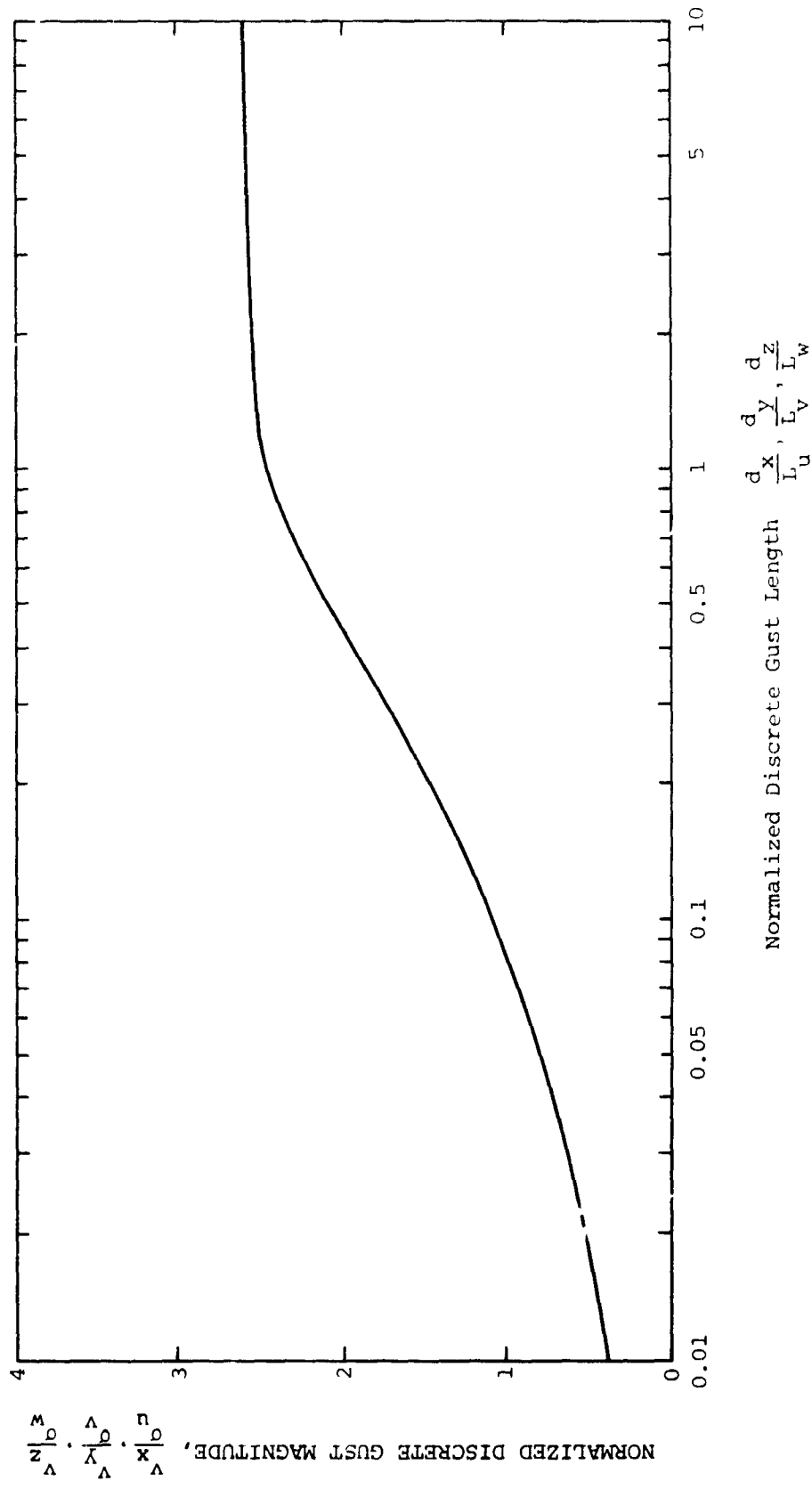

Figure 7 Magnitude of Discrete Gusts

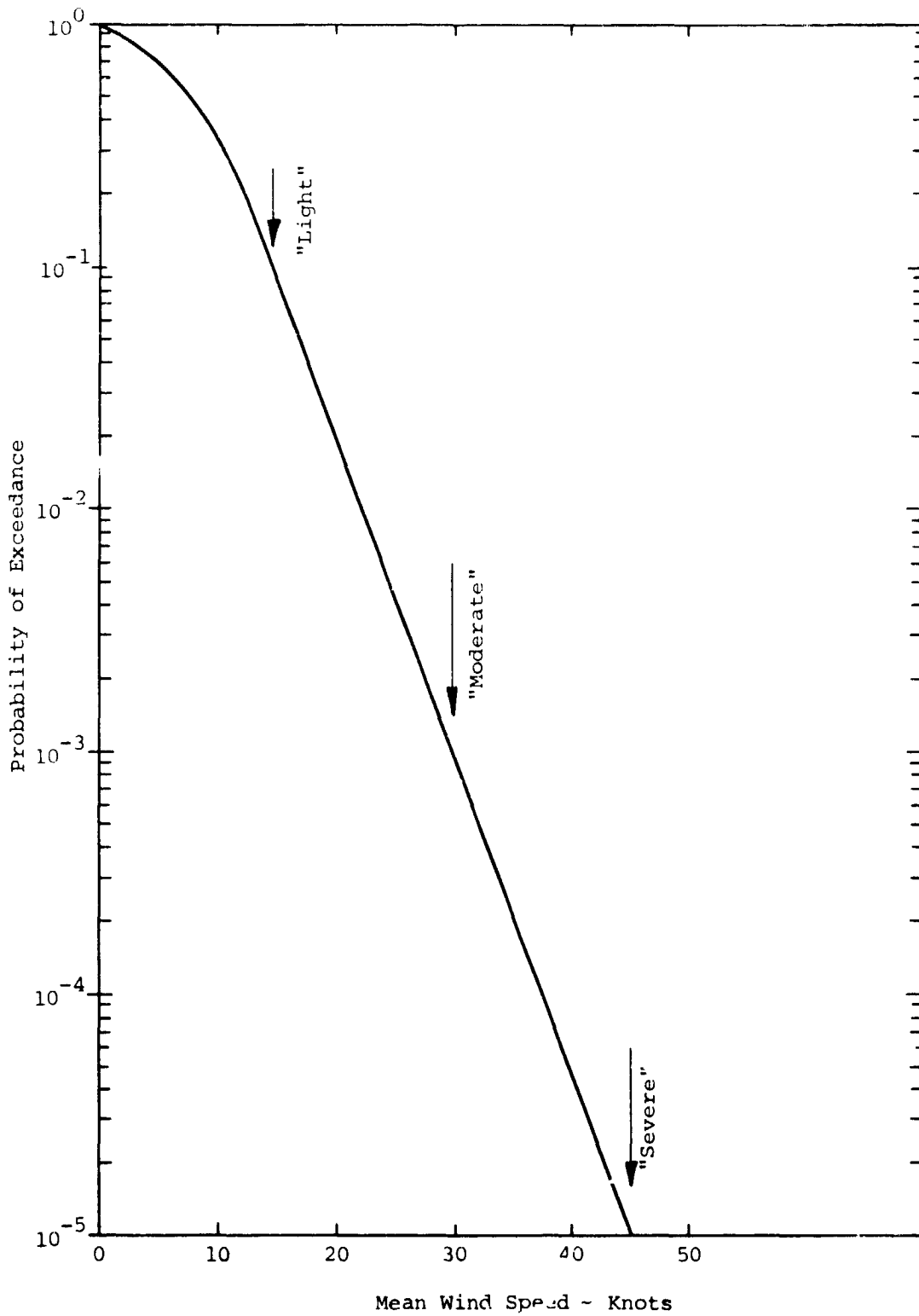

Figure 8 Probability of Exceeding Mean Wind Speed at 20 Feet

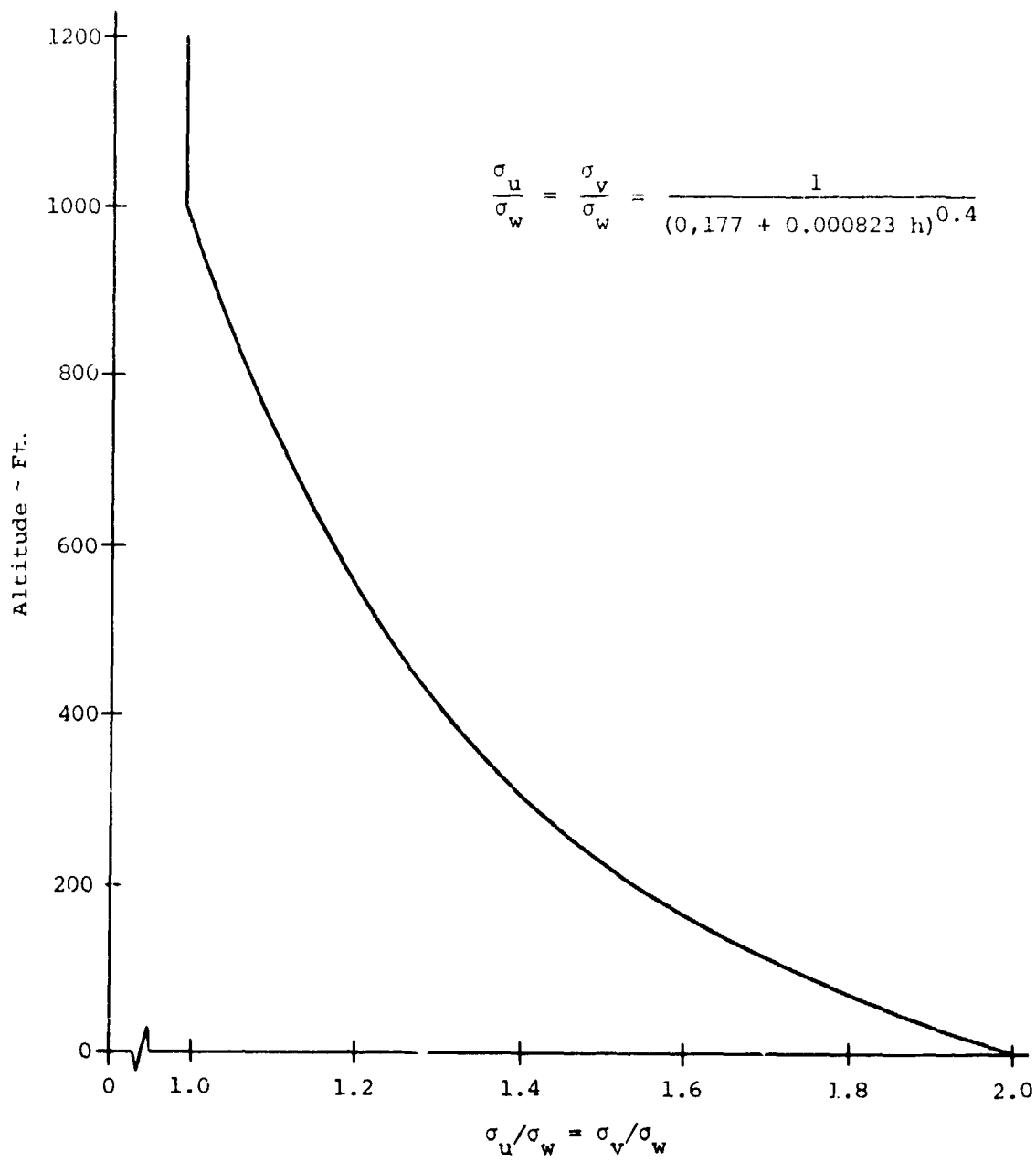

Figure 9 Horizontal Turbulence RMS Intensities

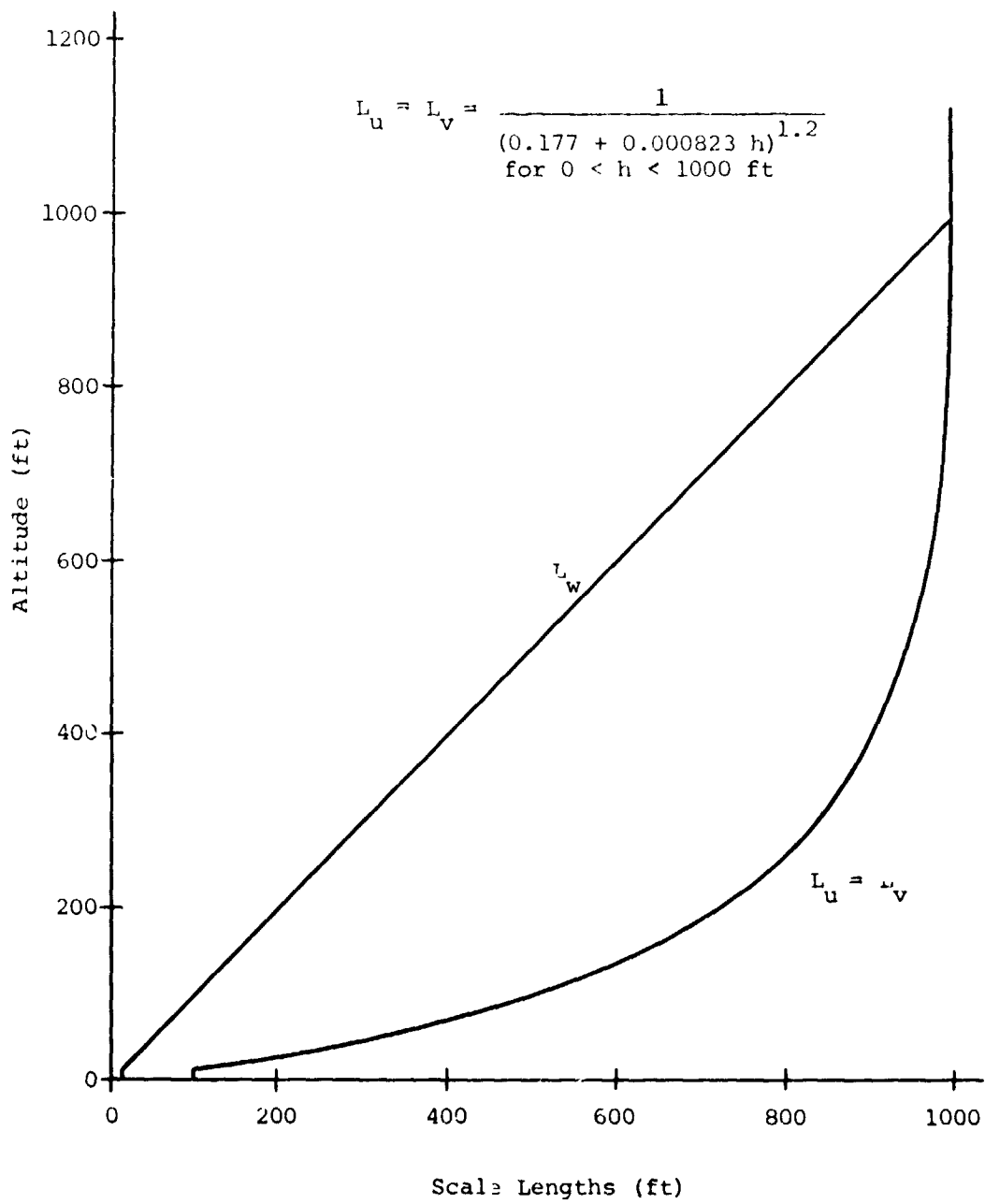

Figure 10 Low Altitude Turbulence Integral Scales

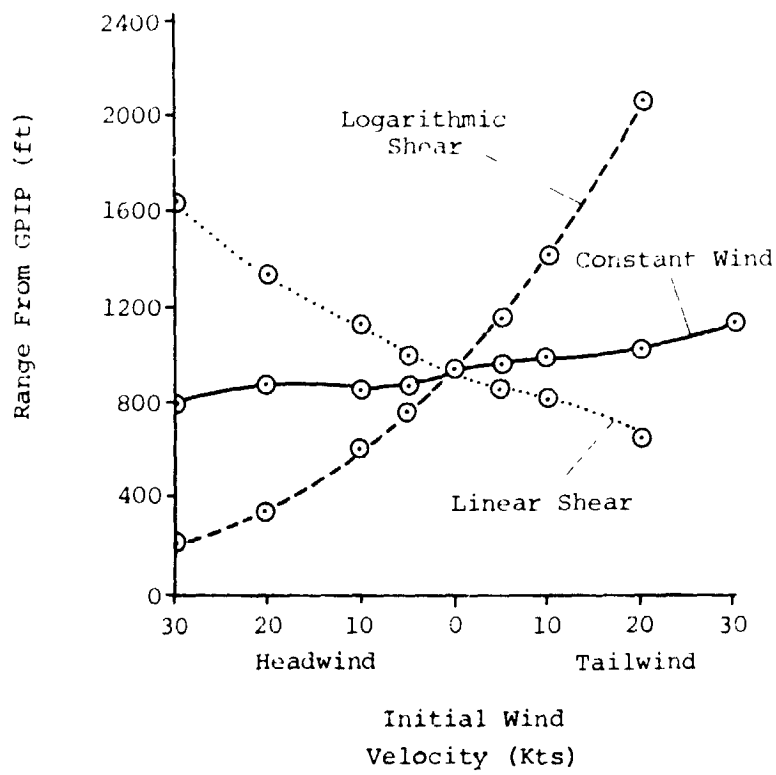

Figure 11 Effect of Wind Shear on Touchdown Dispersion

N79-17418

Aircraft Icing

Porter J. Perkins

NASA Lewis Research Center

Solutions to the problems of aircraft icing have been investigated through research and development in the following areas:

- A. Meteorology
- B. Test Facilities
- C. Ice Protection Systems
- D. Effects of Ice on Performance

Since icing is a meteorological phenomenon, it is certainly appropriate to address the problem at this workshop on environmental inputs to aviation systems. I will therefore, concentrate on the meteorology of icing and its measurements and bring in the other areas only as they relate to the meteorological aspects of the problem.

Measurements

The basic meteorological parameters of concern to icing are Liquid Water Content (LWC), temperature, droplet size, and extent of the icing conditions. The ranges of these parameters are generally known. Ability to forecast discrete values from synoptic data may still need improvement. This is important since the severity of icing for a particular aircraft component is a function of these values. Past work, (Ref. 1) has provided the following ranges of these parameters.

LWC- up to 1.5 gms/m^3
(less than 0.6 gms/m^3 for
90% of the icing clouds)

Temperature - down to -35°C
(above -20°C for 90% of the icing clouds)

Droplet Size- 5 to 50 microns (volume median
around 15 microns)

Extent of icing- up to 200 miles (under 50 miles
for 90% of icing encounters.

Figure 1 shows measured values of LWC as a cumulative frequency distribution. A frequency distribution of icing cloud temperatures is given in Figure 2. Distance flown in icing during a given icing encounter is plotted as a frequency distribution in Figure 3. These icing-cloud statistics are an aid in forecasting and aircraft operations. The above data were gathered over a period of about 5 years during which 3200 icing encounters were measured. Airline and Air Force aircraft collected the data using instrumentation supplied by NASA. Areas covered included the United States, Atlantic, Pacific, and Arctic Oceans. The data is, therefore, representative of icing clouds mostly below 20,000 ft encountered during routine aircraft operations.

The probability of experiencing high liquid-water contents is of primary interest in evaluating the icing problem. Water concentrations that are a direct result of the physical process of cloud formations were calculated by considering the amount of water vapor condensed by adiabatic rising air. On this basis, water contents increase with height above the cloud base and with temperature at the cloud base. A probability distribution of liquid-water content was obtained from these relations using the measured frequency distributions of icing cloud depth (Figure 4) and temperatures (Figure 2). The calculated probability of liquid-water content is shown as a dashed line in Figure 1. Note the measured points are about two-thirds of the calculated values. The actual water concentrations in the clouds would be expected to be less than the full adiabatic amount because of precipitation forming and falling out of the clouds and also because of the entrainment and mixing of dry air from outside the clouds.

However, the opposite has been measured. Figure 5 shows an unusual occurrence of measured LWC exceeding both the calculated moist adiabatic temperature, lapse rate and a lapse rate exceeding the moist adiabatic based on a measured cloud top temperature. The existence of water contents significantly exceeding possible theoretical values was explained in this case by considering cloud droplets falling from cloud layers above the level of this icing cloud layer.

Instrumentation

The standard method for measuring LWC and droplet size over 30 years ago was the rotating multicycinder technique (Ref. 2). This measurement principle applies calculated water droplet trajectory data with respect to cylinders to determine LWC and droplet size from the ice catch on cylinders of various sizes. The number of supercooled droplets that strike and freeze on the cylinders is a function of

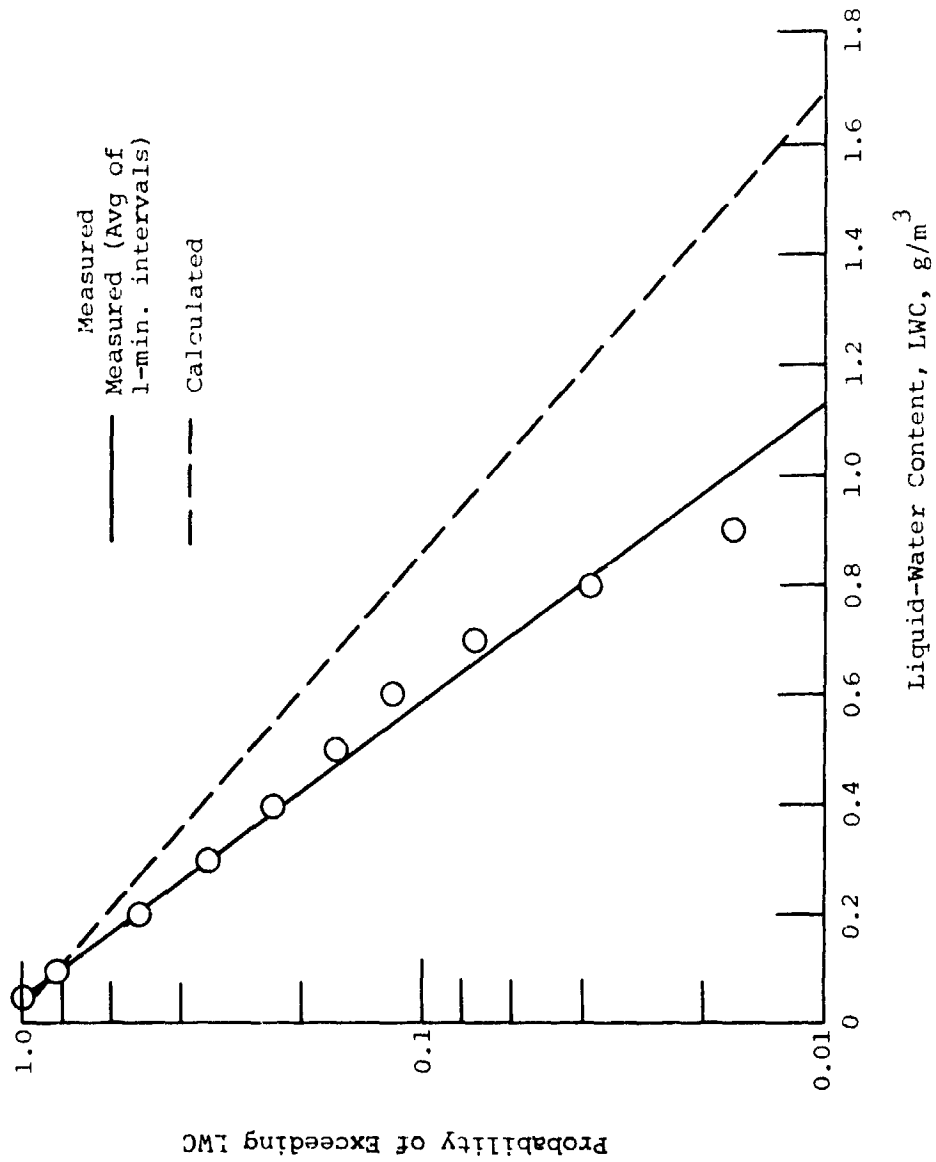

Figure 1 Cumulative Frequency Distributions of Measured and Calculated Liquid-Water Contents in Icing Clouds

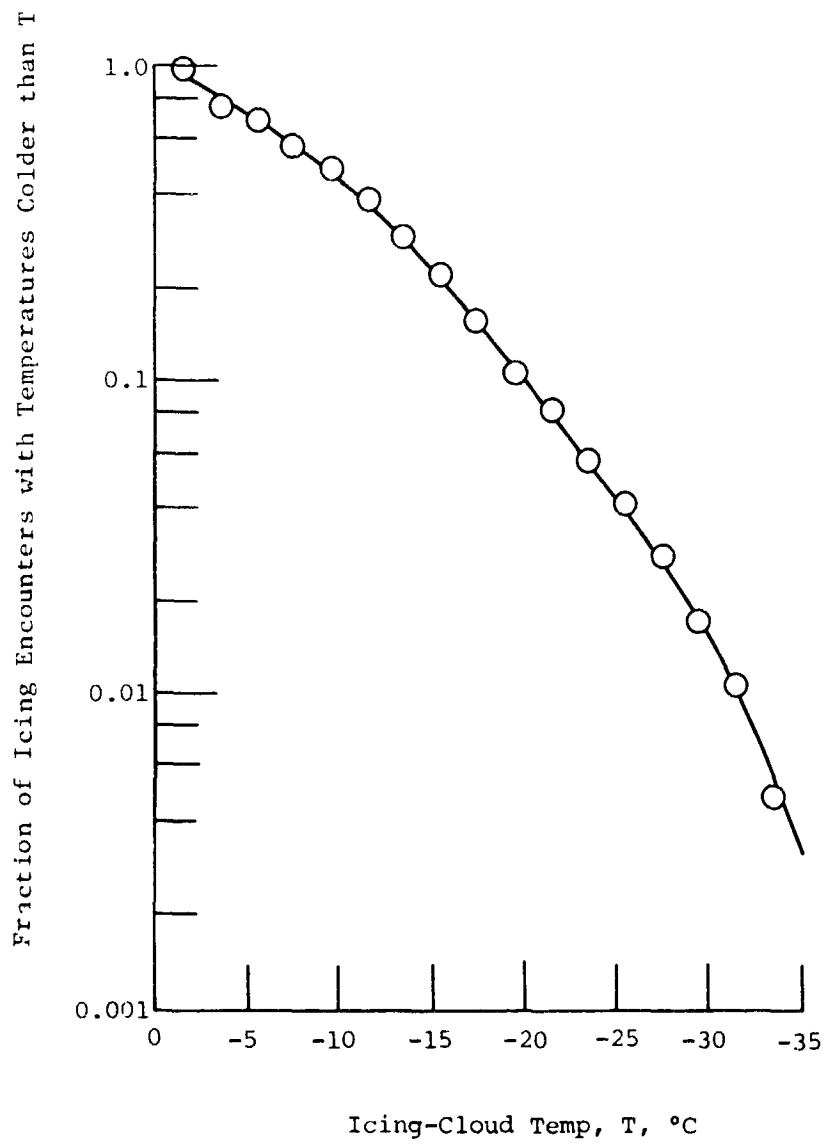

Figure 2 Cumulative Frequency Distribution of Temperature of Icing Clouds

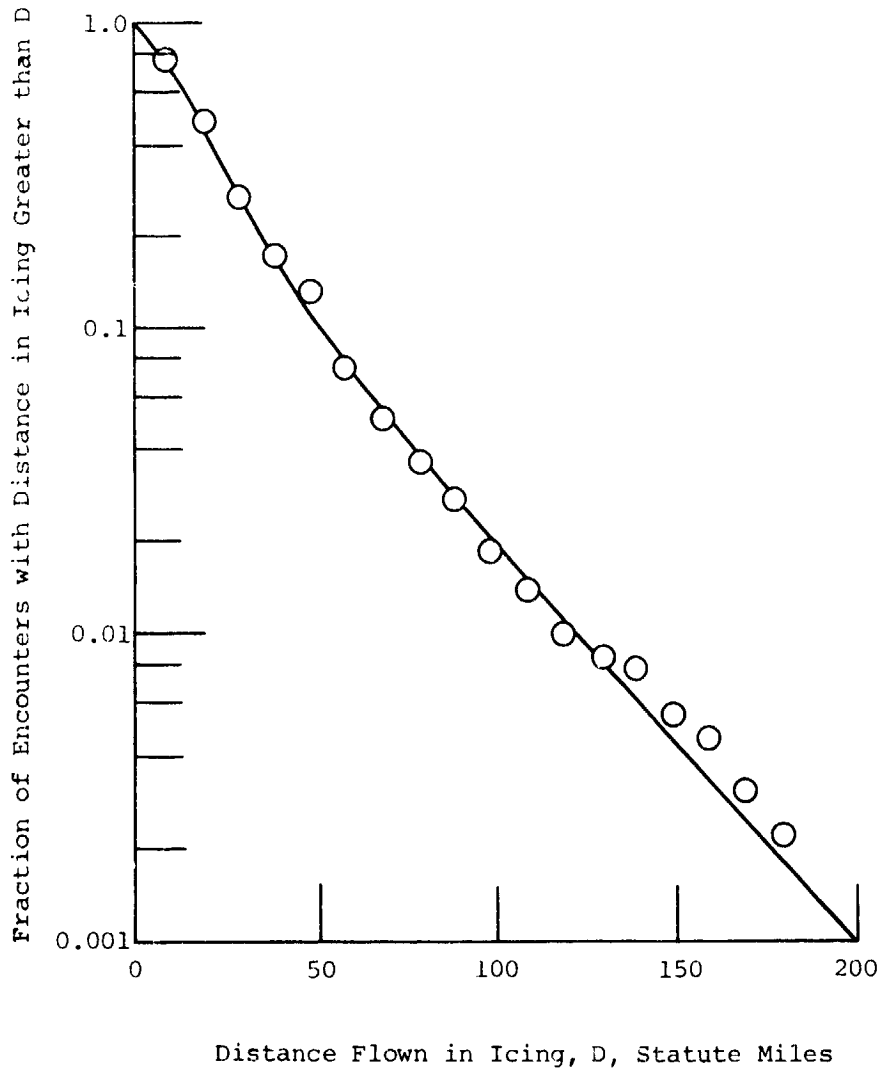

Figure 3 Cumulative Frequency Distribution of Distance Flown in Icing During Encounter

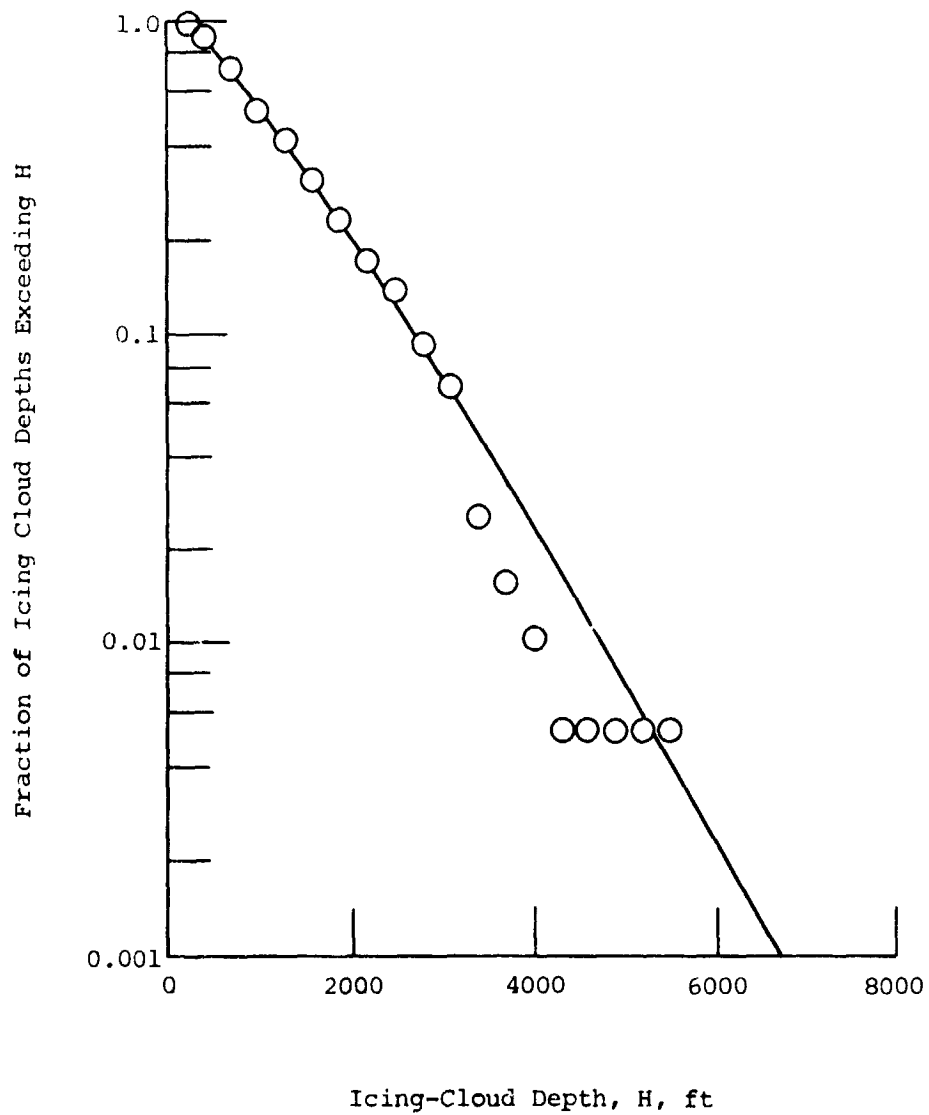

Figure 4 Cumulative Frequency Distribution of Depth of Icing-Cloud Layer

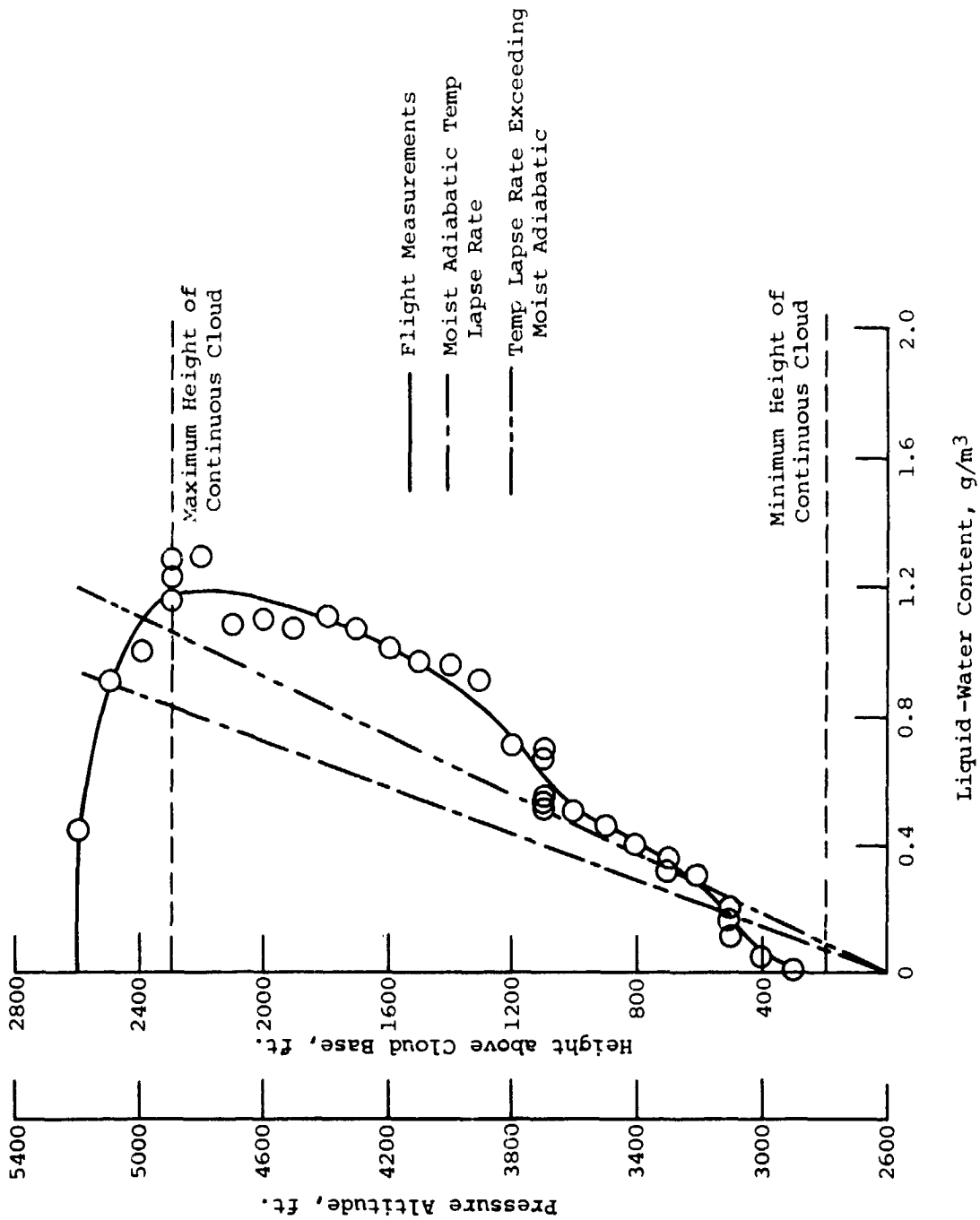

Figure 5 Icing Cloud of High Liquid-Water Content

the cylinder size and of the flight and atmospheric conditions, as well as the inertial properties of the droplets. The LWC and droplet size distribution are determined by a comparison of the measured weight of ice collected on each of the cylinders with the amount of droplet impingement obtained from the calculated water-droplet trajectories for cylinders of the same size and for the same flight and atmospheric conditions. Figure 6 is a photo of a set of multicylinders extending from an aircraft fuselage.

This was a tedious method with limited accuracy because each cylinder's ice catch had to be weighted, usually on return to the ground. With today's technology, the same principle could be used but with on-line sensing of the weight of ice catch on each size cylinder.

For the measurement of LWC only, a single size of cylinder of collection surface of high collection efficiency can be used. Two versions of this approach were used to provide the measurements presented earlier. The rate of ice accretion was the primary measurement. This was calibrated against the multicylinder method to obtain LWC.

One type of ice rate meter employed a rotating disk. A photo of the face of this unit is shown in Figure 7. Ice thickness was measured by a feeler along with the rotational speed. A more simplified ice rate meter utilized the loss of dynamic pressure picked up by small holes when plugged with ice. Cyclic de-icing of the plugged holes provided a continuous measurement of rate of ice accretion since the thickness of ice required to plug the holes was a known constant. A sketch of this operating principle is shown in Figure 8. Installation on an airplane aircraft is shown in Figures 9 and 10. This operating principle has also been used for an ice detector.

This instrument was also used for certification testing of ice protection systems on commercial airliners. In fact, it is still being used. This past winter (1977-78) Boeing borrowed an ice rate meter from NASA for icing intensity-measurements during tests in natural icing conditions of engine inlet anti-icing modifications to the B-727. They wanted the same instrument as was previously used.

Test Facilities

Ground based icing test facilities have centered on icing wind tunnels and static test stands using sprays or natural icing conditions. In-flight tests have utilized spray rigs since natural icing conditions are both infrequent (best only, in certain areas) and difficult to use for specific tests. Spray rigs are convenient, but are difficult to follow and stay in the cloud and to provide uniform test conditions. The icing research tunnel at NASA-Lewis Research Center in Cleveland is presently active.

ORIGINAL PAGE IS
OF SECURITY

C.S.-78-657

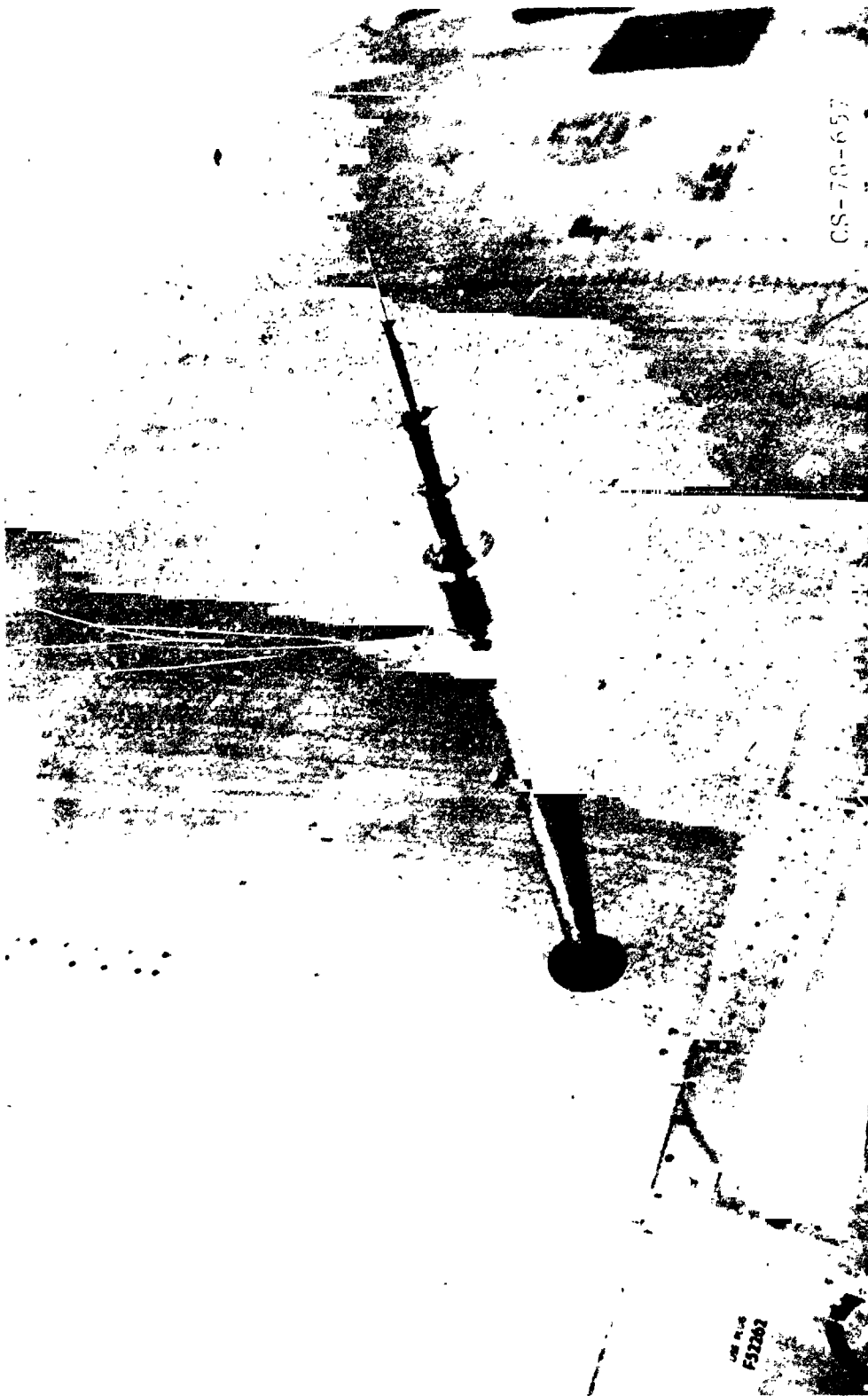

USE PLUG
F32262

Figure 6 Rotating Multicylinders

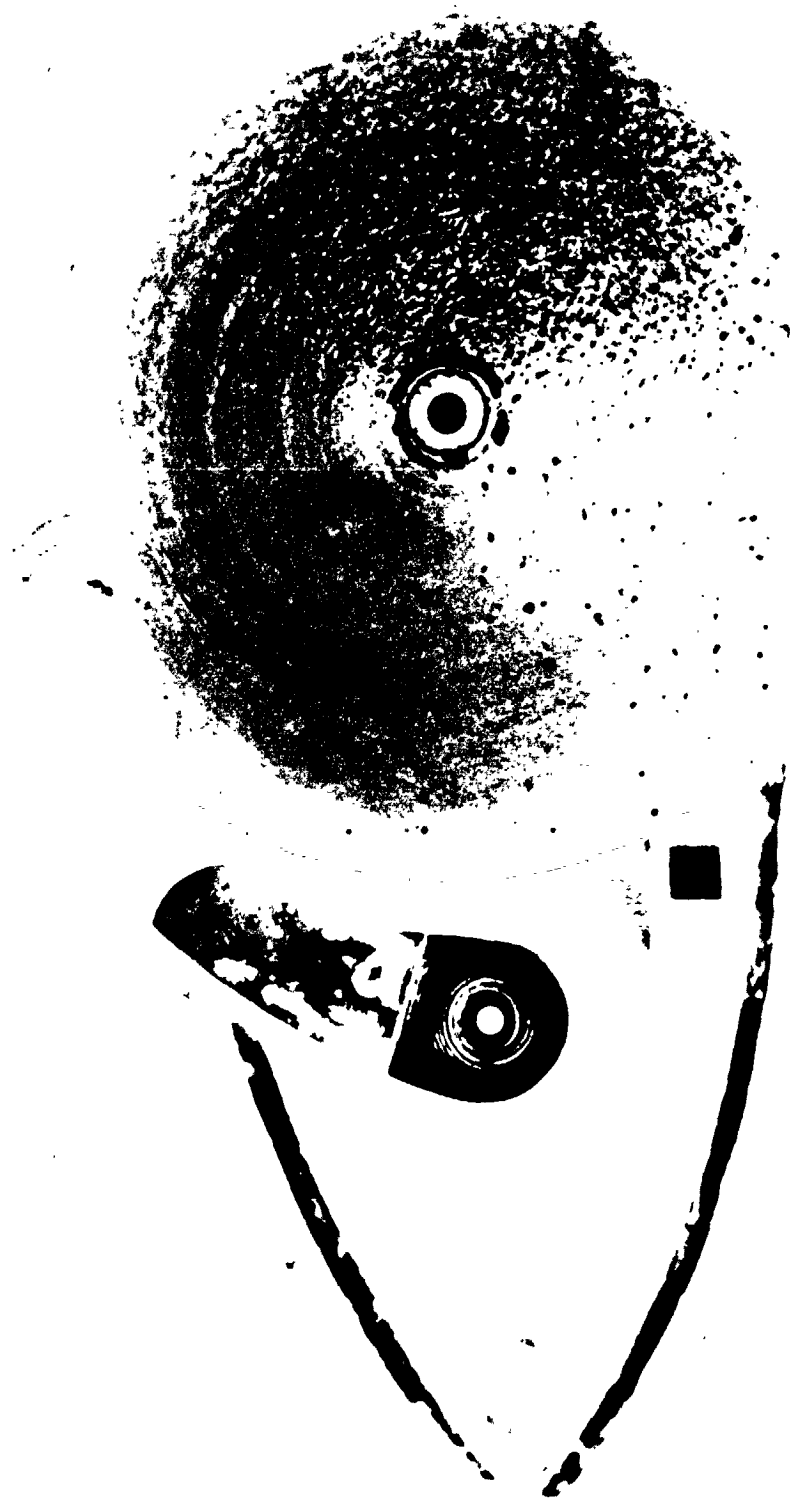

Figure 7 Icing Rate Meter-Disk Type

CS-78-661

ORIGINAL PAGE IS
UNCLASSIFIED

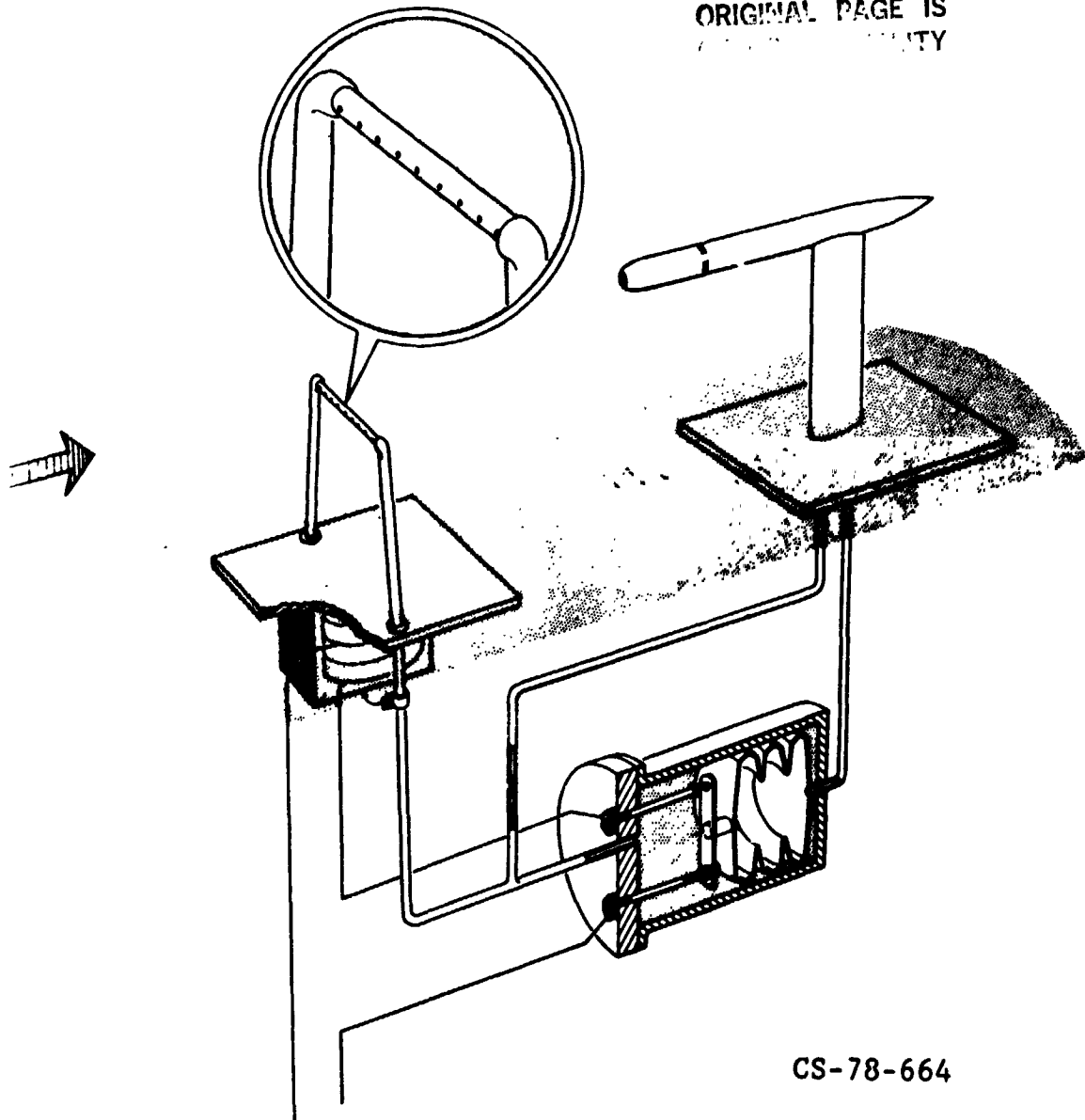
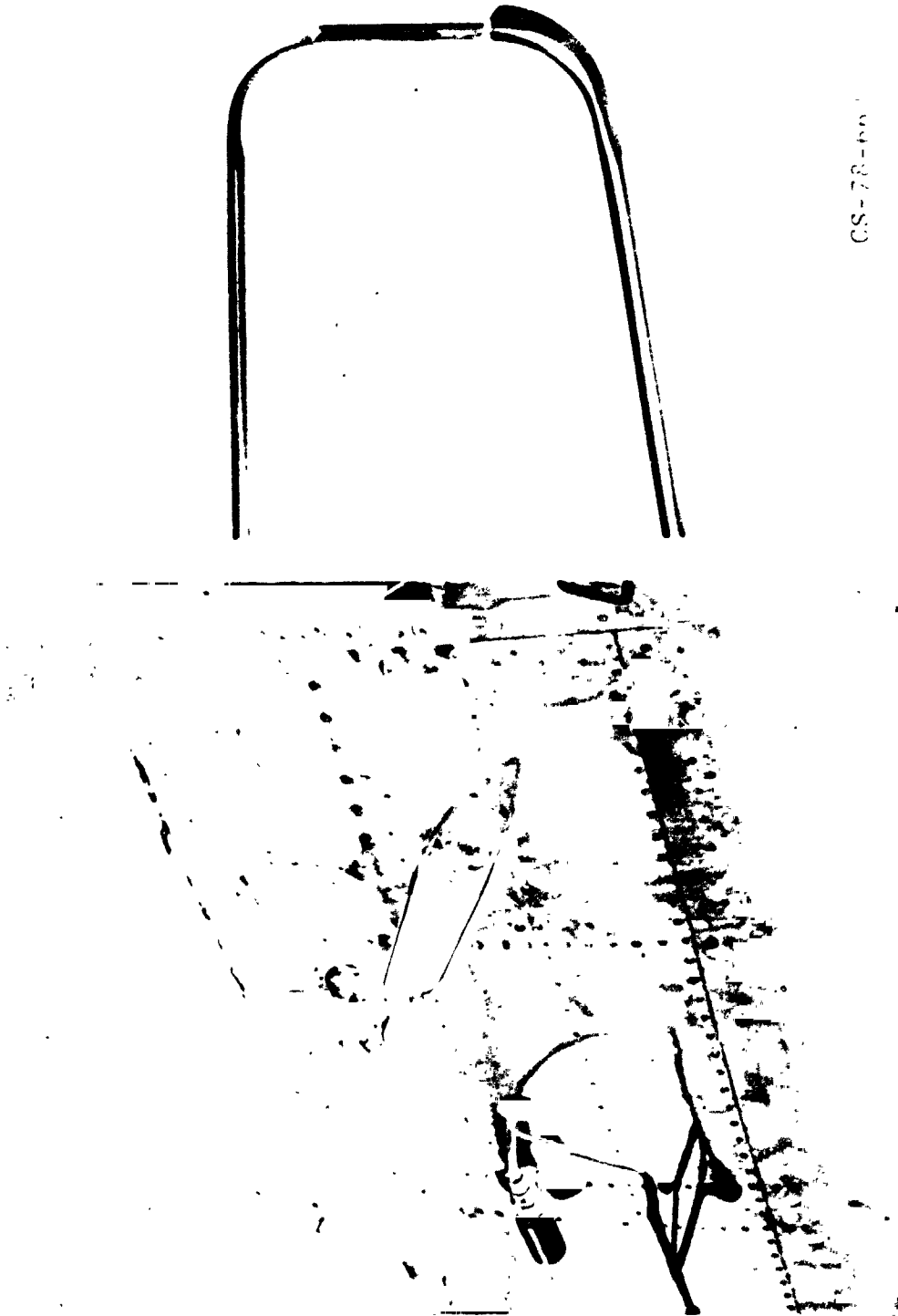

Figure 8 Icing Rate Meter Pressure Type



Figure 9 Icing Rate Meter-Pressure Type On Airliner

ORIGINAL PAGE IS
OF POOR QUALITY



CS-78-60

Figure 10 Icing Rate Meter-Pressure Type Installed

Both wind tunnel and in-flight spray rigs require simulation of icing conditions and their measurement. Instrumentation described above was used to control and assure proper simulation of natural icing conditions. Quick response improved instrumentation is still needed to define test conditions in flight spray rigs.

Ice Protection Systems

Development of ice protection concepts (mechanical, thermal or liquid) is usually performed in test facilities. The final product, however, is evaluated and certified in natural icing conditions. Icing cloud forecasts with its associated meteorology are important here, not for avoidance, but for minimum flight time in seeking the desired icing conditions. Boeing, in the icing tests mentioned above, has spent three months looking for icing conditions to satisfy the certification requirements. This problem is the same as in the past.

Effects of Ice on Performance

Tolerance of aircraft components to various icing conditions is quite variable in terms of the effect on performance. A classic example is airfoil icing where large accretions of rime ice on the leading edge has no adverse effect, whereas a thin layer of frost over the wing surface can cause a large reduction in maximum lift coefficient. Thus, the effect of various icing conditions on new designs must be assessed. The need here is to categorize the icing conditions such as type of ice accretion, intensity (ice accretion rate), and the meteorological parameters which determine these conditions.

Concluding Remarks

Obviously, considerable progress on the problems of aircraft icing has been made since work started about 40 years ago. The range of icing parameters has been well documented. Forecasting of icing is also well in hand although the severity of the icing may not be precisely predicted. Considerable work has been done on providing proper test facilities and from this has come adequate ice protection systems.

The advent of high altitude jet aircraft with their associated rapid climb and descent through cloud layers minimized the overall icing problem. Thus, the level of R&D effort has been reclined over the past 20 years. Despite this lack of recent development effort, much of the past work will apply to today's needs.

An area which needs further development would appear to be icing instrumentation. Today's technology should be applied to improved measurement techniques perhaps based on previously developed principles. On-line, fast response instruments would help in flight testing particularly in simulated spray cloud testing behind a tanker.

REFERENCES

1. Perkins, Porter J.: Summary of Statistical Icing Clouds Data Measured Over United States and North Atlantic, Pacific, and Arctic Oceans During Routine Aircraft Operations. NASA Memo 1-19-59E, 1959.
2. Brun, R.J.; Lewis, W.; Perkins, P.J.; and Serafini, J.S.: Impingement of Cloud Droplets on a Cylinder and Procedure for Measuring Liquid-Water Content and Droplet Sizes in Supercooled Clouds by Rotating Multicylinder Method. NACA Report 1215, 1955.

Visibility in Aviation

Charles A. Douglas

Introduction

The distance at which one can see and recognize objects and lights has been a very important factor in determining the safety and regularity of travel since ancient times, and it becomes especially important with the advent of air travel. Reports of prevailing visibility and of ceiling have been made by the Weather Services since the early days of cross-country flight. At that time, these reports were based upon the observations of human observers. Even today many of these reports are still based upon visual observations, although from the beginning there has been a desire to replace these subjective observations with quantitative measurements.

The purpose of this paper is to present an overview of the development of instrumental methods of making cloud height and visibility measurements and to discuss the limitations of these measurements.

Measurements of Cloud Height

Knowledge of the height of the cloud cover is essential for aircraft operations conducted under visual flight rules (VFR) and is one of the parameters determining whether VFR operations are legally permissible. Until recently a specific minimum ceiling was included with a specified minimum visibility in the minimums used to determine whether an approach to an airport was permissible under instrument flight rules. Ceiling is no longer used in determining minimums for instrument approaches. Instead, a decision height (DH) is specified for instrument approaches made with the aid of an electronic glide slope and a minimum descent altitude (MDA) is specified for instrument approaches made without an electronic glide slope. Today ceiling measurements are used as advisory information indicating to the pilot the probability of his being in visual contact with the airport at the DH or MDA.

Until the early 1940's, ceiling observations at night were made visually using a ceiling projector to produce a spot on the base of a cloud directly above it, and triangulation using a visual measurement of the angle of elevation of the spot from the observers position to determine the height of the spot. Daytime measurements were much more difficult requiring the use of such techniques as pilot balloons, visual estimates based upon cloud types, and pilot reports.

W 1 0 7 1 - 2 5 7 4

To remedy these difficulties the Weather Bureau requested the National Bureau of Standards to develop a photoelectric method of determining cloud height in the late 1930's. The fixed-beam ceilometer was developed by Laufer and Foskett in response to this request (1) and was put into service in 1943. Experience with this instrument in service and at the Landing Aids Experiment Station indicated that in fog the frequency of measurements of this instrument (two indications every 12 minutes) was too slow. To meet the need for more frequent indications, the rotating-beam ceilometer was developed to provide an indication every 24 seconds, (2). This instrument includes numerous improvements in electronic design and in the projector as well.

Extensive tests were conducted by the Weather Bureau to determine the effects of the differences in the geometry of the scanning methods of the two instruments, (3). These differences are illustrated in Figure 1, and the results of the comparison are illustrated in Figure 2. The rotating beam ceilometer was put into service following these tests. Over the years it has been improved, particularly in the method of readout. Originally, the observer viewed a cathode ray tube and determined the cloud height visually from the position of the maximum return signal. Now a digital readout has been developed making possible the input of ceilometer measurements into automatic weather stations.

It should be noted that neither ceilometers determine the ceiling as ceiling is defined. Instead, they measure only the height of the clouds above a fixed point. The input of an observer is required to determine if this measurement is representative of the ceiling.

To overcome this difficulty, the National Weather Service is experimenting with a network of three ceilometers located seven miles from each other on the legs of an equilateral triangle coupled into an automatic weather station.

For many years studies of the possibility of replacing the rotating beam ceilometer with a pulsed-laser cloud height detector have been conducted by the National Weather Service and the Air Force Cambridge Research Laboratories (4,5) in order to obtain a more accurate presentation of cloud structure. These studies indicate that these new instruments provide operationally useful measurements of cloud height. Studies are continuing but hardware problems are still a limiting factor.

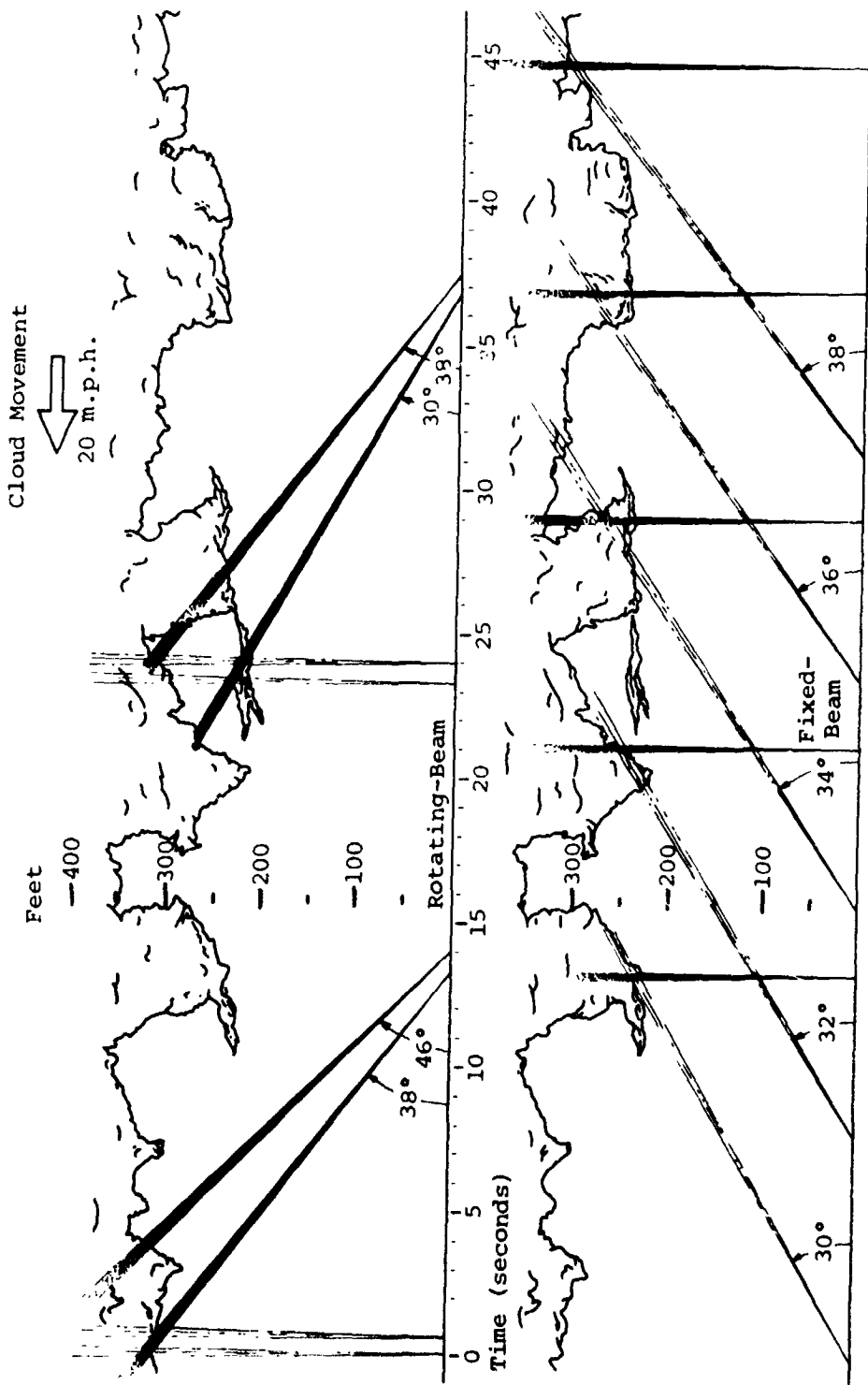

Figure 1 Pictorial comparison of the differences in the geometries of the fixed-beam and rotating-beam ceilometers. (From reference 3).

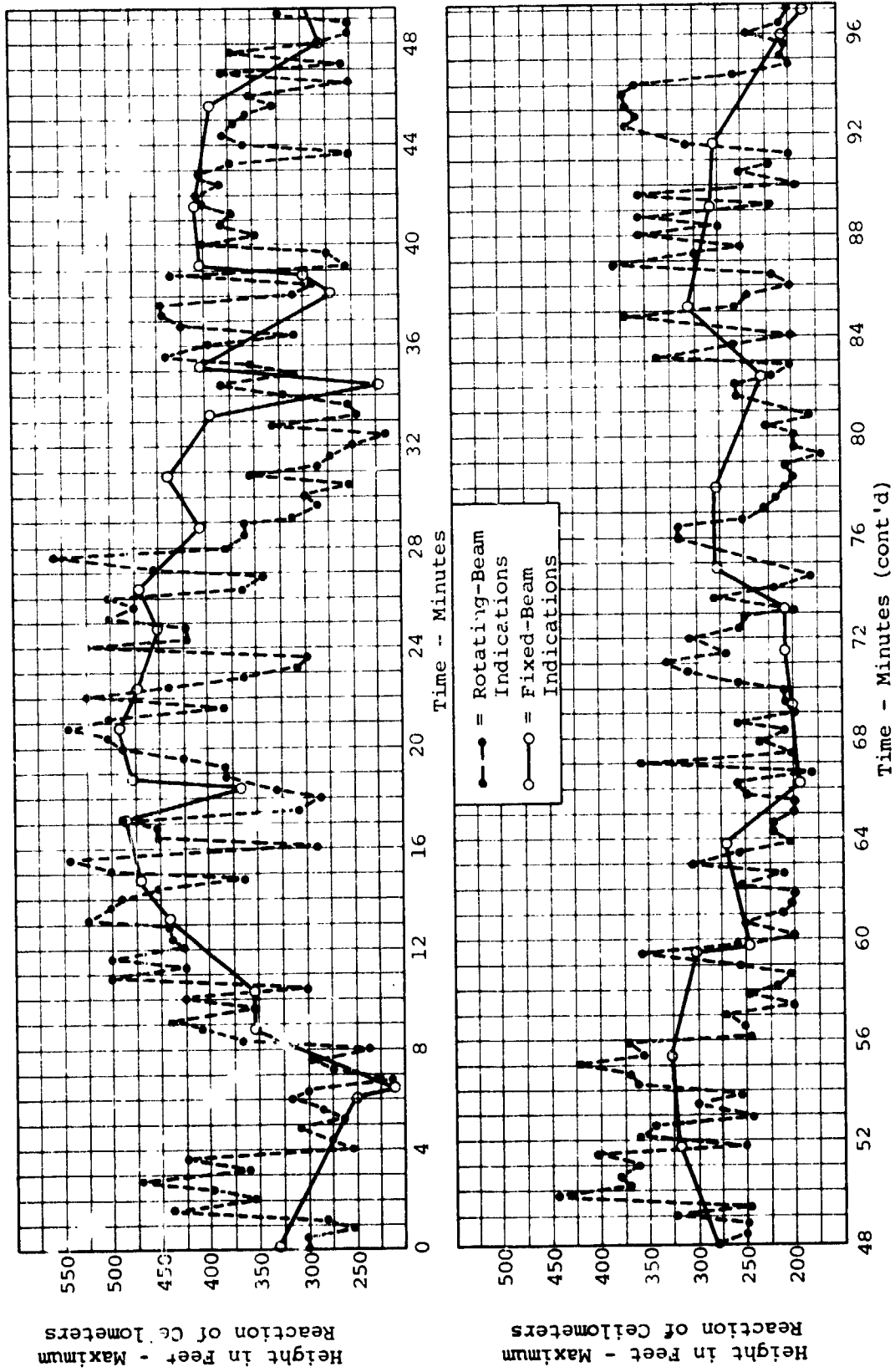

Figure 2 Comparison of cloud heights measured by fixed-beam and rotating-beam ceilometers. (From reference 3).

Assessment of "Prevailing" Visibility

By Visual Observations

From the beginning, the visibility prevailing around an airport has been assessed by an observer the maximum distance that objects or lights could be seen and, in theory, determining the distance equalled or exceeded over at least one-half of the horizon circle. In practice the limited number of objects and lights suitable for use in different directions has often severely limited the technique to assessing the prevailing visibility on the basis of a single object or light. Even with this restriction, marks are usually not available at many of the desired distances and estimates must be made on the basis of a few marks. There is also the problem of individual differences in observer characteristics and in the criteria they use to determine if a mark is "visible".

Instrumental Methods

Development of the Transmissometer

Recognizing the problems encountered with visual observations of prevailing visibility, the Civil Aeronautics Administration, in 1940, requested the National Bureau of Standards to develop an instrument to determine the (prevailing) visibility at airports.

The first model of the transmissometer was constructed. Then, as now, the transmissometer consisted of three units: an unmodulated light source operating at a fixed intensity; a receiver with an output in the form of pulses with the pulse frequency proportional to the illuminance on the receiver; and an indicator consisting of a counting rate meter. It was field tested on Nantucket Island, Massachusetts, during the summer of 1941. During these tests numerous observations were made correlating the visual range of black objects by day and of lights by night with the transmissometer readings, (6).

Daytime Transmissometer Calibration

The observation points used in the daytime calibration are shown in Figure 3. The following conclusions were drawn from these observations.

a. Koschmieder's law is applicable in correlating the visual range of black objects by day with transmissometer measurements. Koschmieder's law, as applied to black objects with a sky background, may be written as

$$e_o = T^D \quad (1)$$

where

- e is the constant threshold of the observer
- T is the atmospheric transmittance per unit distance, and,
- D is the visual range of the object.

When plotted using a log scale for D and a log-log scale for T, as was done in Figure 3, Equation 1 yields a straight line with a slope of 1, with ϵ as a parameter.

b. The value of the constant threshold applicable to weather observers should be 0.055 instead of the value of 0.02, accepted at that time. Thus, Equation 1 becomes

$$0.055 = T^D \quad (1a)$$

which may be written as

$$0.055 = t_b^{D/b} \quad (1b)$$

where t_b is the transmittance measured by a transmissometer with a baseline of length b. Equation (1b) is the daytime transmissometer calibration equation.

The value of 0.055 for the contrast threshold was confirmed in studies conducted at the Landing Aids Experiment Station in the late 1940's and at Washington National Airport in the early 1950's, (3). This value has been used in the U.S. for obtaining the visual range of objects from transmissometer measurements since the introduction of the transmissometer and is being used today.

The World Meteorological Organization has agreed upon a value of 0.05 (7). Use of this value will yield a visual range about 3% greater than that obtained using a value of 0.055.

Consideration should be given to changing U.S. practice to the use of 0.05 at an opportune time.

3.2.1.2 Nighttime Transmissometer Calibration

In obtaining the nighttime calibration, lights having an intensity of 25 candelas were used as marks. This intensity was selected as being representative of the intensities of lights, then used by a weather

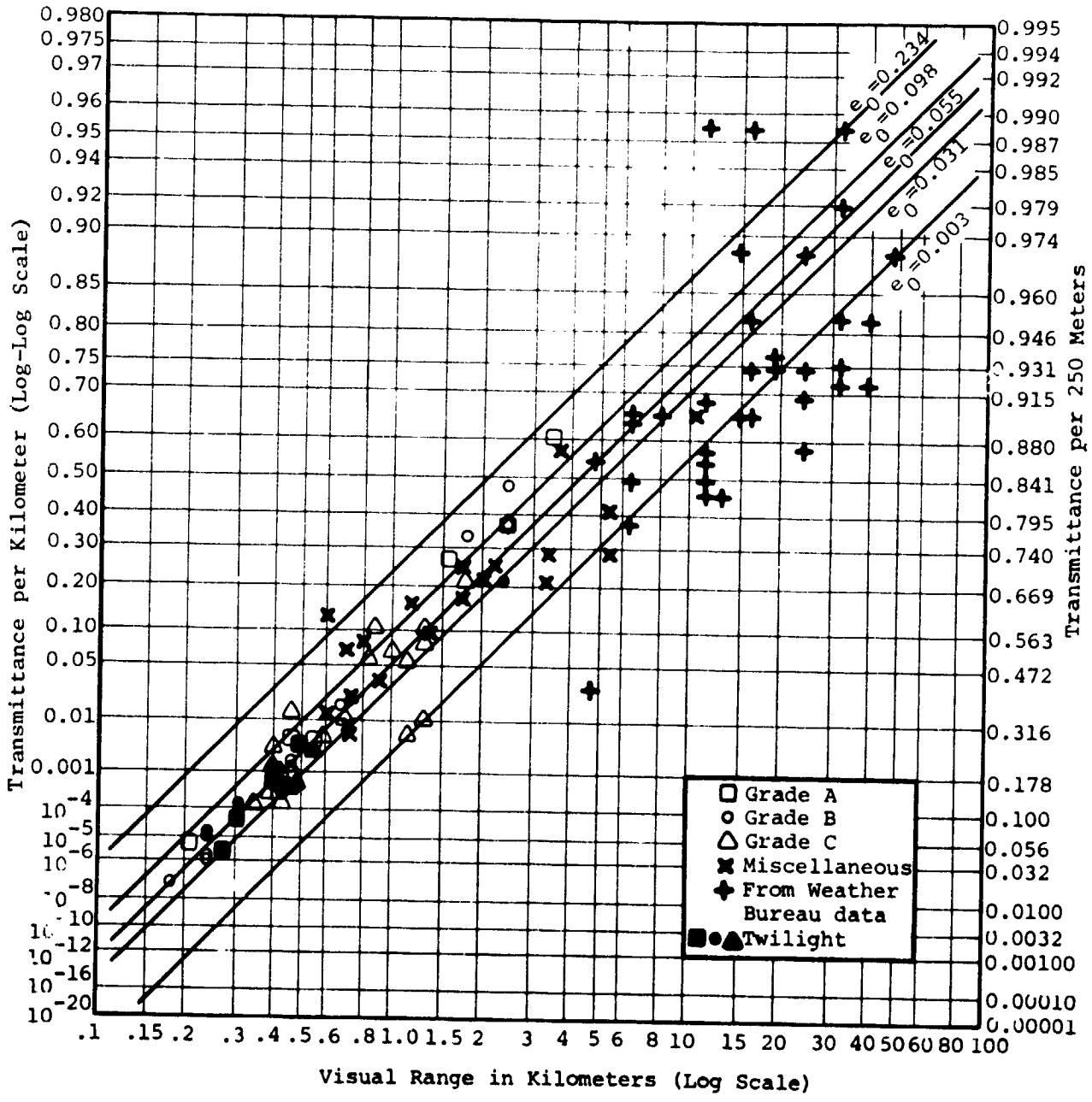

Figure 3 Daytime transmissometer visibility calibration curve derived from data obtained at Nantucket Island.

observer and by a pilot in approaching an airport. At the time of this calibration there was a strong move by meteorologists to select the intensities of the lights to be used by the weather observer so that the visual range obtained would be identical to that of a black object observed by day through the same atmosphere. This principle was rejected because the intensities required for low visibility conditions would be unrealistically low.

However, the practice of using a system which would yield a common scale for day and night visibilities was used in Europe for many years even though the nighttime values are not consistent with what a pilot would see. A renowned British lighting expert stated that the pilot's reaction on learning of this practice was, "one of incredulity mixed with resentment." The World Meteorological Organization has adopted the U.S. practice of using lights of low or moderate intensity as nighttime visibility marks (7). However, this practice has not been adopted by the International Civil Aviation Organization, nor by the maritime services.

The observations used in developing the nighttime transmissometer calibration are shown in Figure 4. Note that the calibration curve does not follow Allard's law, which may be written as

$$E = IT^D/D^2 \quad (2)$$

where

E is the illuminance threshold,

I is the intensity of the source being observed,
and

T and D are defined as before.

Instead, the calibration curve is represented by the relation

$$S = IT^D/D^2 \quad (3)$$

where S is a constant.

It should not be inferred from this statement that the illuminance produced by a point source is not given by Allard's law, but rather that the minimum perceptible illuminance is not a constant and is such a function of T and D such that Equation (3) is a satisfactory representation.

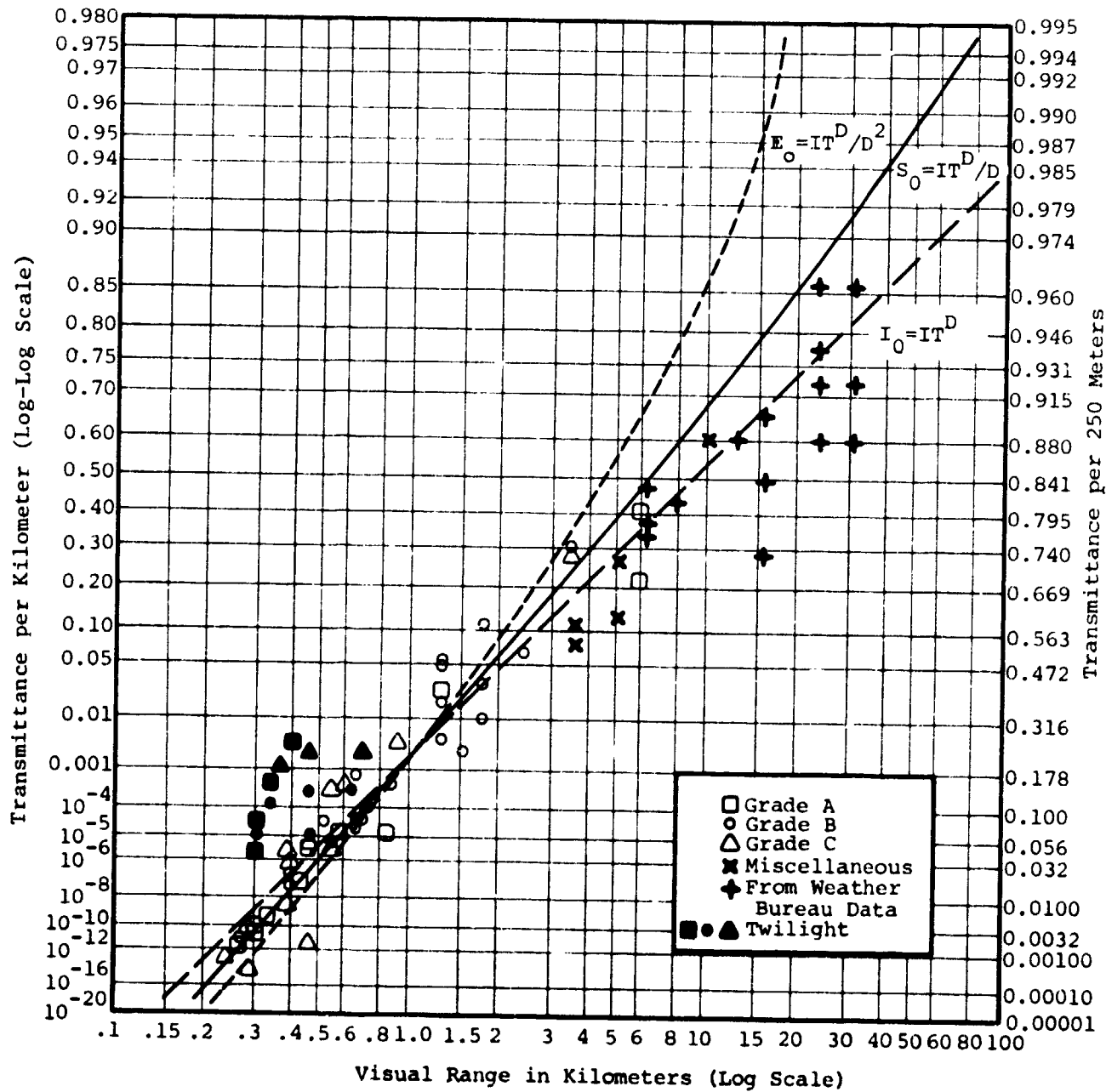

Figure 4 Nighttime transmissometer visibility calibration curves, based upon a light intensity of 25 candles, derived from data obtained at Nantucket Island

A value for S of 0.052 was determined for the nighttime calibration curve when D is in kilometers and of 0.084 when D is in miles. Thus, Equation (3) becomes

$$0.084 = 25T^{v/V}, \quad (4a)$$

or

$$0.084 = 25t_b^{(v/b)/V} \quad (4b)$$

where D is in miles. Equation (4b) is the nighttime transmissometer calibration equation.

The nighttime transmissometer calibration was also confirmed by the Weather Bureau studies at Washington National Airport (3) and is used by U.S. weather services for obtaining runway visibility at night.

Application of the Transmissometer

The observations at Nantucket indicated that because of the spatial and temporal variations in fog density, shown in Figures 3 and 4, use of a single instrument at an airport to determine the prevailing visibility was not feasible except under exceptional conditions such as the absence of trained observers or suitable marks. In addition, because of the effects of instrument errors, an instrument with a single baseline could not cover the entire range of visibilities. However, its use to provide indications of visibility in an area remote from an observer, such as an approach appeared to be feasible. As a consequence of these findings, no further efforts to use instruments to measure prevailing visibility were made for many years.

Sensor Equivalent Visibility

The advent of automatic weather stations and the continuing problems with the subjective estimates of visibility by observers have led in recent years to a renewed interest in replacing the observer. The concept of measuring atmospheric clarity with an instrument and expressing the results of the measurements as the visual range that an object or light would have in a uniform atmosphere if the measured clarity has been designated as "sensor equivalent visibility," (8). Studies of the use of sensors for this purpose are being conducted both by the National Weather Service and the Air Force Cambridge Research Laboratories using back-scatter and forward-scatter meters, respectively (8,9). Transmissometers are not being considered because of the need for dual-, or even triple-baseline instruments. These studies show a reasonably good correlation between the indications of these instruments and transmissometer indications as shown in

Figure 5. However, others have found that different calibrations of back-scatter instruments are required for fog, rain, and snow conditions.

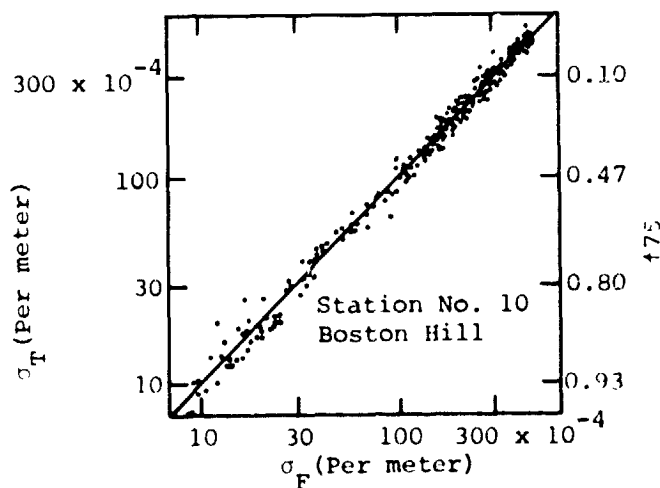

Figure 5 Comparison of measurements of Scattering Coefficient and Transmittance. (From reference 9)

Although the use of a single sensor may be suitable for most meteorological applications, it is of questionable value in indicating visibility conditions applicable for take-offs and landings because of the possibility of extreme differences in visibility conditions over the approach and runway area going undetected.

The use of networks of sensors covering the area of interest is being studied by the National Weather Service, which has a test network of three sensors spaced at the vertices of an equilateral triangle with two-mile legs. Studies of a network of instruments are also being conducted by the Air Force (10).

An important consideration in the use of scattering-type meters is that they are not fail-safe; that is, decreased or zero outputs produced by instrument failure produce indications of excessively high or unlimited visibility, whereas with a transmissometer such failures yield too low or zero-visibility indications. Thus, adequate monitoring is required to avoid potentially hazardous erroneous indications.

Development and Application of the Runway Visibility Concept

During the period 1946-1950, the Landing Aids Experiment Station (LAES) was operated at the Arcata, California, Airport, under the joint sponsorship of the Air Force, Navy, and Civil Aeronautics Administration to study methods of fog dispersal and approach-light system configurations. All existing NBS-type transmissometers (six) were moved to LAES and, except for one, were used on 500-foot baselines along the instrument runway and in the approach zone to measure fog density in specific areas during tests. The other transmissometer was installed on a 3000-foot baseline to provide a measure of the prevailing transmissivity.

Although the purpose of the installation of transmissometers at LAES was not to test their use as visibility meters at airports, during the flight tests observers on the ground reported the horizontal visual range of selected objects or lights periodically, and pilots reported their visual contact height and the visual segment of the approach and runway (edge) lights during an approach and touchdown. These data formed an extensive data base correlating visual observations with transmissometer measurements.

The blockade of Berlin began in the summer of 1948 and the renowned airlift was started. The very high flight frequency required that after a missed approach an aircraft return to its base without making a second approach. This procedure imposed high demands on the accuracy of weather observations, and the existing routine procedures using visual observations were not adequate. Efforts to improve the situation were initiated immediately.

In November of 1948, Mr. G.H. Stocker, Meteorologist of LAES, suggested to the Chief of the Air Weather Service, USAF, that transmissometers located in the touchdown and approach zones of the instrument runway be used in conjunction with a ceilometer in the approach zone as a standard operational weather reporting procedure, stating that: "Observations at LAES, as well as at other airports, have indicated that in weather conditions at or below ceilings of 200 feet and visibilities of $\frac{1}{2}$ mile, the irregularity and variability of the respective weather elements requires continuous, automatic, objective meteorological measurements that are actually representative of 'pilot's weather' in the instrument approach zone." The arrangement of instruments recommended was a transmissometer and ceilometer in the approach zone about 3000 feet from the runway threshold and a second transmissometer near the runway touchdown zone.

The Air Weather Service accepted the LAES recommendation, and in 1950 NBS was requested to provide the Air Force with 25 instruments. Concurrently, kits for modifying ceilometers to permit remote indication and to improve their response during periods of low visibility were being procured through other channels.

Following operational suitability tests, the Air Force proceeded with the installation of modified ceilometers and the transmissometers. However, by the time installations were started the Weather Bureau, on the basis of tests at Washington National Airport, recommended that the transmissometer in the outer approach zone be omitted. The Air Force followed their recommendation with two exceptions. The Navy purchased and installed instrumentation following the lead of the Air Force.

The application of transmissometers to civil operational use was, with two exceptions, more deliberate than in military aviation. The systematic study of the proposed visibility meter system was initiated. Studies were made of the spatial variations in visibility and ceiling, and tests of the instruments located as proposed by Mr. Stocker were made at Washington National Airport. A study was also made of the correlation between observed prevailing visibility and transmissometer readings. The general conclusion of these studies was that the transmissometer and rotating-beam ceilometer were suitable for operational use; that the transmissometer calibration was satisfactory, and that the second transmissometer installed in the approach zone was not cost effective.

Operational use of the Washington National installation began in December 1952. Experience soon indicated that variations in visibility occurred so rapidly that they could not be handled by the regular weather observer and a readout was installed in the control tower. Conversion from the transmissometer transmittance measurements to visibility was done by means of the equations and threshold constants developed at Nantucket and verified by subsequent testings.

The criterion used to judge the suitability of instrument program was approach success. Records of missed approaches at Washington National Airport during inclement weather were examined to determine if the operational use of the transmissometers and ceilometer had produced an improvement. Only approaches during periods where the visibility was less than one mile or the ceiling was below 500 feet were used in the analysis.

From this analysis it was concluded that the data indicated that the low-weather instrument approach success had been improved; the inference being that runway observations are more nearly representative of conditions experienced by the pilot in landing. Although some or all of the improvement might have been due to other causes, the results were encouraging.

Except for the analysis of missed approach data, the Washington National Airport studies were limited to observations from near ground level. A study at MacArthur Field, conducted by the Sperry Gyroscope Company and monitored by the Weather Bureau, was designed to complete the program. The objective of this study was to evaluate the transmissometer-ceilometer system in relation to the operational requirements of the instrument approach by correlating the measurements obtained from the instruments with what the pilot saw simultaneously from the cockpit during ILS approaches.

The pilot or co-pilot reported a) vertical contact, b) approach light contact, and c) threshold contact. The approach light system was the earliest system consisting of 14 neon bars each having an intensity of about 1000 candelas.

Because the approach lights at MacArthur Field were low-intensity lights and the Sperry pilots were very familiar with the field and surrounding terrain, the flights at MacArthur Field were supplemented by flights at Idlewild, where a high-intensity approach-light system was installed. A total of 468 instrument approaches, 409 at MacArthur and 59 at Idlewild, were made in low ceiling and/or low visibility conditions.

Conclusions drawn by the Weather Bureau were, in part, that the transmissometer-ceilometer combination provided a sound method for remotely measuring weather in the approach zone. The results of these tests were sufficiently convincing that by the spring of 1954 transmissometer systems were in operational use or scheduled for installation at 17 civil airports.

Note that throughout this period, the transmissometer readings were converted to visibility, not runway visual range. These visibility readings were designated as runway visibility (RVR) in order to distinguish them from visibilities obtained by direct observation.

Development of the RVR System

Initial Development

Even as the runway visibility systems were being placed into operational use, plans were being made to convert to a system which indicated runway visual range instead of meteorological visibility. The request for further development was motivated by several factors: a) European practice in reporting RVR; b) a desire to report visibility conditions in units which were more representative of what the pilot saw during an approach and landing; and c) the desire to take into account the increased visual range obtained with high intensity approach and runway edge lights and to obtain authority to land in more dense fogs without lowering the numbers representing the visibility minimums. (The relative importance of these factors is uncertain.)

By mid-1955 plans had been made for an RVR installation at Newark, and the values of the parameters to be used in converting transmissometer readings to RVR had been fixed. Allard's Law was used to compute runway visual range. An intensity of 10,000 candelas was chosen as being representative of the in-service intensity of a high-intensity runway-edge light in the directions from which it would be viewed during a flare and landing. At this time no consideration was given to the changes in intensity which result from dimming the lighting systems in conditions of less dense fogs.

No special tests were made to determine the night and day illuminance thresholds to be used in the conversion to RVR. The thresholds were based upon engineering judgments considering past experience and practices. A value of 2 mile candles (2 lumens per square mile) was chosen for the nighttime illuminance threshold. In the early days of aviation, an illuminance threshold of 0.5 mile candle was used. In the 1940's, an illuminance threshold of 1 mile candle was used by some engineers both in the United States and in Great Britain. The increase was made in consideration of the increased losses in sloped, multi-element, "bird-proof" windscreens, the increased number of lighted instruments in the cockpit, and the increased complexity of flying. A further increase was made to 2 mile candles for use in the RVR conversion to obtain a value which was conservative in nature.

Although during daylight the illuminance threshold is roughly proportional to the background luminance, a single daylight illuminance threshold of 1000 mile candles was selected. Again, a direct readout was provided in the tower using a specially calibrated analog meter.

Development and Application of the RVR "Computer"

Even before the first RVR system with a meter readout was placed into service, plans were being made for the replacement of the meter readout with a digital display. A Working Group was established to review past experience and the continuing studies. Based upon its study, the Group recommended the following design features:

- 1) The nighttime and daytime thresholds then in use should not be changed. After considerable thought, adjustment of the daytime threshold for changes in background luminance and for twilight was rejected as not being cost beneficial.
- 2) An intensity of 10,000 candelas should be used as representative of the runway edge lights operated at full intensity but 2000 and 400 candelas should be used when the lights were operated at intensity steps 3 and 4, respectively.
- 3) The use of 100 foot increments in reporting RVR was not practical because of the great variability of fog density with time. Studies of the temporal variation of RVR computed from NBS transmissometer records indicated that a 200 foot increment was suitable for RVR's below 4000 feet and 500 foot intervals were suitable for greater RVR's.
- 4) An averaging period of 45 to 60 seconds should be used.
- 5) The minimum RVR to be displayed should be considerably lower than 2000 feet. To accomplish this, the length of the transmissometer baseline should be reduced from 750 to 500 feet.
- 6) Since in daylight, the meteorological range exceeded the RVR at high transmittances and the minimum visibility requirements for the jet aircraft then being introduced was in this transmittance region (4000 feet RVR or 3/4 mile meteorological visibility), the indicated RVR should be based upon the visual range of black objects whenever it exceeded the RVR. Otherwise the fog would be less dense under minimum conditions at RVR equipped airports than at airports using RVR or weather station observations.
- 7) The contrast threshold to be used in computing the visual range of black objects was to be 0.055, that obtained in the Nantucket studies.

By mid-1962, ten computers had been installed and another 160 were being installed or on order.

The relation between transmittance and RVR based upon these parameters is shown in Figure 6.

Studies of RVR Thresholds

At the request of the airlines, who stated that the thresholds were unnecessarily high, the choice of thresholds was reconsidered in 1957 after three years of operational use of the RVR system at Newark. The results of this experience and flight tests at Newark and MacArthur Field were examined. The conclusion reached was that no change in the thresholds was warranted. However, the examining group recommended that the RVR minimum be lowered from 2400 to 2000 feet, a change which accomplished the effect desired by the operators.

Further studies of the RVR thresholds were made by Lefkowitz and Schlatter of NAFEC (11), who reexamined the flight test data obtained during the period 1945-1960, and in addition, made direct observation of the visual range of runway lights by a group of stationary observers from a position approximating that of a pilot on the runway. The RVR thresholds were found to be conservative and no change was recommended.

Present Status of the RVR System

As instrument landing systems, high-intensity approach-light systems with sequenced flashing lights, and high-intensity runway-edge lights were installed, there was an increasing demand for RVR systems with a goal of installing an RVR system on every fully instrumented runway.

The years following these developments have been evolutionary with no significant changes in operational principles. The RVR minimums were lowered as confidence in the RVR system increased with experience and as improvements were made in the electronic aids and lighting systems. The transmissometer baseline was shortened to 250 feet on runways intended for Category III service to permit measurements of RVR down to 600 feet. The computer was redesigned to provide for displaying RVR as low as 600 feet and modernized by using modern solid-state techniques. At some airports, the computers were replaced with AMOSV (automated meteorological observation station, Mark V) which could free four computers. The transmissometer itself is now being modified to use solid-state-techniques. As the RVR minimum was reduced, better information of visibility conditions along

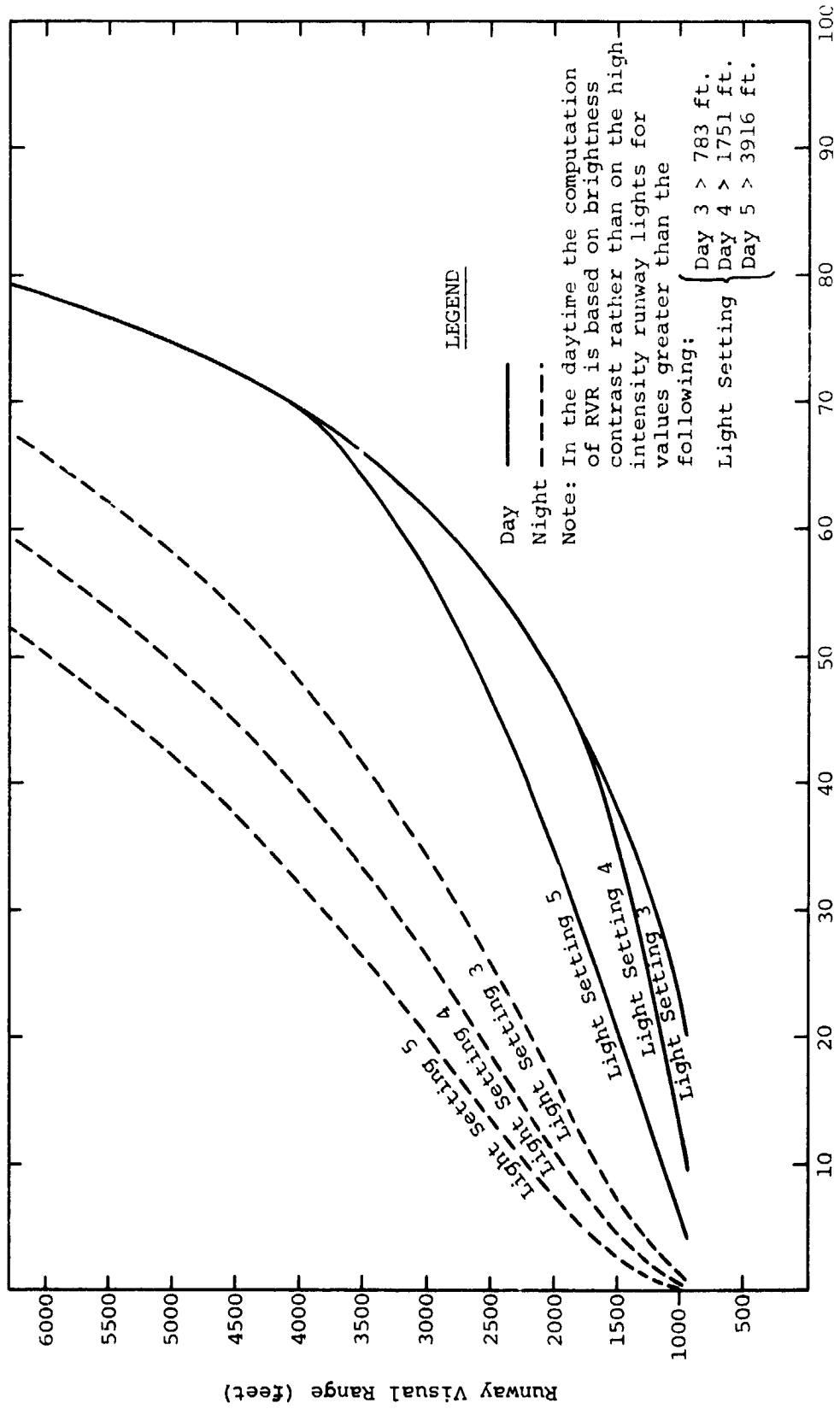

Percent Transmittance - 500 foot baseline

Figure 6 RVR calibration based upon three intensity settings and object visibility

the runway beyond the touchdown zone became necessary, and transmissometers were installed at the midpoint and end of some runways.

However, the basic transmissometer, the contrast and illuminance thresholds, the illuminance level for transition from day to night scales, and the reporting increments have not been changed since the first use of the RVR system, nearly 20 years ago.

Current Problems in the Assessment of RVR

Effects of Temporal and Spatial Variations on Fog Density

Note: In this section only variations of fog density in horizontal directions are considered. The effects of variations in the vertical direction will be discussed under "Slant Visual Range."

Spatial and temporal variations in fog density are the most serious limitation to the use of RVR to predict what a pilot will see. Examples are shown in Figure 7, which are based upon records of two end-to-end transmissometers at Arcata Airport. In examining these figures, consider not only the differences between instruments, but also the changes in RVR which occur within a few minutes, remembering that the RVR reported to the pilot is at least two minutes old. Note the sudden drop in RVR occurring at about 10:50 and changes which occur between 12:38 and 12:40 where the RVR indicated by one instrument decreases from 1600 to 800 feet and that indicated by the other increases from 1300 to 1700 feet. What would an instrument on the other side of the runway have indicated? Changes of this type raise the question of the validity of the single digital displays now being used. These changes also indicate a limit beyond which increases in the accuracy of the instrumentation, accuracy of the threshold illuminance and intensities used in the conversion to RVR are not cost effective.

Operating in Category IIIB Weather

Operational Category IIIB is defined as operations under conditions in which the RVR is between 700 and 150 feet (no decision height being applicable) using visual aids for taxiing. We are now approaching operations in this category. This raises several questions not only in the measurement of RVR but also in the design of the visual aids to be used. Among these questions are the following: a) Is the lower limit of Category IIIB, 150 feet, realistic? Points to be considered are: The visual aids currently specified by ICAO are designed for operations down to an RVR of 300 feet. b) Is it cost beneficial to design for visual operations down to 150 ft. RVR?

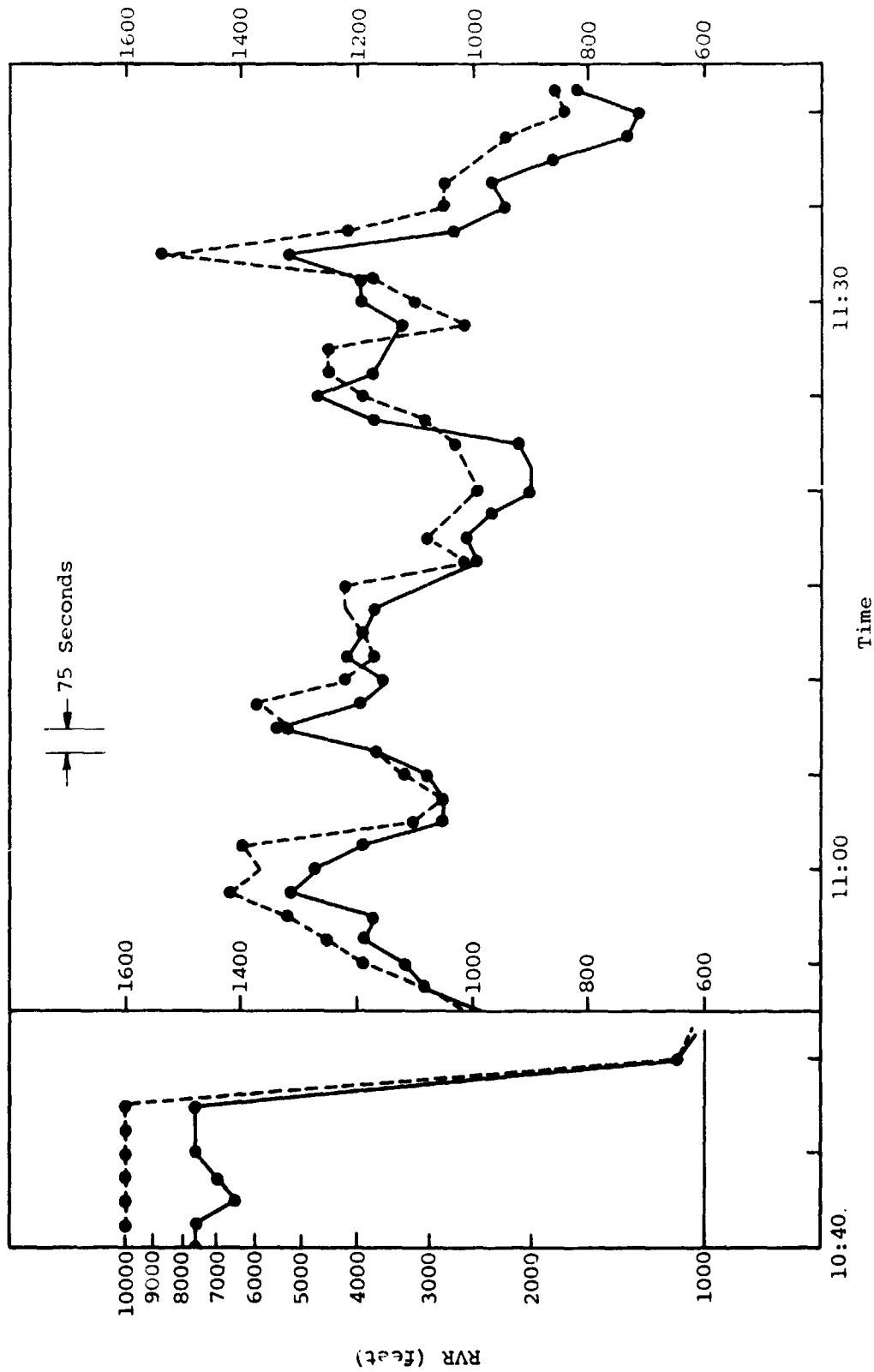

Figure 7 Simultaneous RVR determinations from two end-to-end transmissometers at Arcata, California, October 31, 1965. RVR is based on the step 5, day scale. The integrating period was 75 seconds. Note that RVRs plotted above 4000 feet are based on the visual range of lights, whereas, in practice, RVRs above 4000 feet are based on object visibility.

75 Seconds

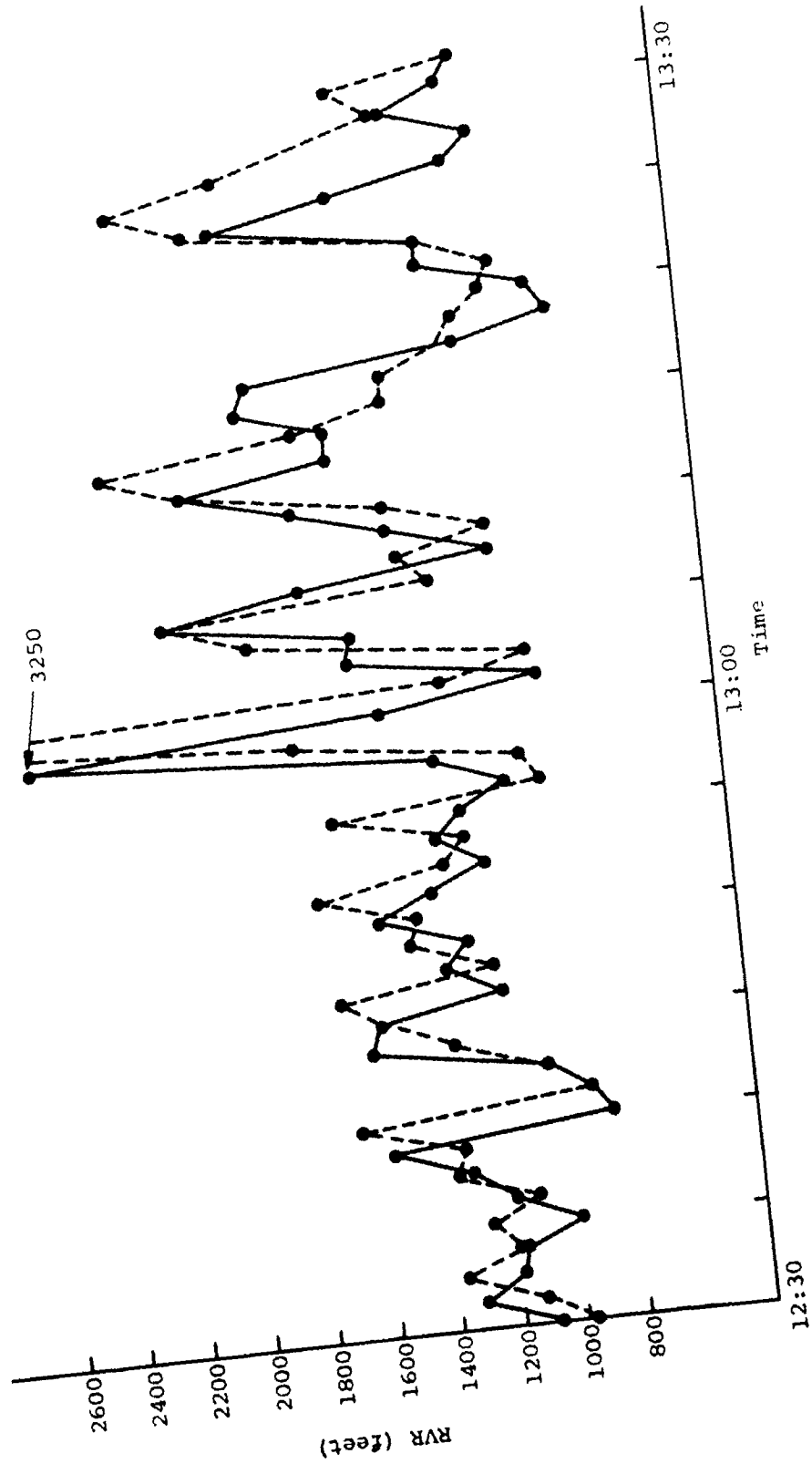

Figure 7 (Continued) (Note change in RVR scale)

The U.S. has very little data concerning the frequency of very low RVR's. The data given in Table 1 are the only detailed data available. These data were taken at Arcata, reputedly the foggiest airport in the U.S. Note the very low frequency of RVR below 400 feet, particularly at night. Detailed data of this type for major airports throughout the U.S. is urgently needed. c) What modifications should be made in the transmissometer to accommodate operations down to the lower limit of Category IIIB? The present instrument with a 250-foot-baseline can operate down to an RVR of 500 feet. With modifications of the circuitry and readout operation down to an RVR of 400 feet by night and 300 feet by day appears to be feasible. A shorter baseline will be required for lower RVR's. The choice is then a single short-baseline instrument or a dual-baseline instrument. The former sacrifices sample length and accuracy at high RVR's and the second results in a more complicated instrument.

In evaluating short-baseline instruments consideration should be given to the effects of the instrument itself upon the fog sample. The effects of the instrument structure, the effects of hoods, the heat developed by the instrument, and, in particular, the effects of the blowers and heaters used to protect the optical surfaces interfacing with the atmosphere upon the measurement of transmittance have been largely ignored, both in the U.S. and abroad. (Some consideration was given to the effects of structure in U.S. instruments when the source and receiver were separated from their power supplies and when a skeletal structure was used to support this instrument.) The effects of these factors are probably insignificant for baselines 250 feet and longer, but become increasingly significant as the length of the baseline is reduced. d) At what height should the transmissometer source and receiver be mounted? The U.S. instruments are mounted at a height of 15 feet. Instruments mounted in accord with the ICAO definition of RVR would have an average height of about $7\frac{1}{2}$ feet, and if the principles of the ICAO definition were applied to the jumbo jets, the average height would be about 15 feet. Some countries use heights as low as about five feet. e) Thresholds. As stated earlier, the U.S. has used illuminance thresholds of 2 and 1000 mile candles, respectively, since the RVR system was put into service, and operational use and later studies have not warranted a change. Yet ICAO has recommended a different set of values given in Table 2 and one country is using a continuous adjustment for background luminance.

TABLE 1
PERIODS OF LOW RVR AT ARCATA AIRPORT

RVR(ft.)	Night				Day			
	1965	1966	1967	Total	1965	1966	1967	Total
1. Total Hours								
700-899	38.4	5.8	20.0	64.2	48.3	33.0	20.1	101.4
500-699	0.2	0	4.5	4.7	16.4	10.9	14.6	41.9
400-499	0	0	0.1	0.1	1.2	3.3	0	4.5
350-399	0	0	0	0	0	0.1	0.3	0.4
300-349	0	0	0	0	0	0	0.5	0.5
2. Number of Occurrences								
Below 900	50	16	39	105	48	41	52	141
Below 700	1	0	16	17	27	23	25	75
Below 500	0	0	1	1	6	6	3	15
Below 400	0	0	0	0	0	1	3	4
Below 350	0	0	0	0	0	0	2	2
3. Average Duration (minutes)								
				Weighted Average				Weighted Average
Below 900	46	22	31	37	60	48	23	43
Below 700	10	0	17	17	36	28	35	34
Below 500	0	0	5	5	12	34	8	20
Below 400	0	0	0	0	0	5	19	15
Below 350	0	0	0	0	0	0	16	16

TABLE 2

ICAO RVR THRESHOLDS

Pilot contrast threshold - 0.05 (dimensionless)

	<u>Illuminance Threshold</u>		<u>Background Luminance</u>
	(lux)	(Mile Candles)	(cd/m ²)
Night	8 x 10 ⁻⁷	2	4-50
	or 10 ^{-6.1}		
Intermediate Value	10 ⁻⁵	26	51-999
Normal Day	10 ⁻⁴	260	1000-12000
B right Day (e.g., sunlit fog)	10 ⁻³	2600	more than 12000

Further consideration should be given to these thresholds and to the effects of changing the U.S. thresholds. Note that changing a threshold without changing the minimums changes the fog density at which operations are permitted. Since the minimums were developed empirically with fog density as the independent variable, such changes should be approached with caution. f) Measurement of Taxiway Visual Range. Measurements of slant visual range are of little significance for all Category III operations, and likewise, measurements of runway visual range are of little significance for Category IIIB landings, except to determine whether there is adequate visual guidance to permit executing a turn from the runway to the taxiway. However, knowledge of the visual guidance existing along the taxiways is of significance. With the RVR's characteristic of operations in Category IIIA and higher RVR's, adequate visual guidance along the taxiways is seldom an important consideration. However, during Category IIIB operations, it may be the limiting factor. Very little consideration has been given to the problem to date.

Assessment of Slant Visual Range

Ever since the earliest days of the use of instruments to assess visibility conditions at airports, pilots and operators have expressed a need for "measurements of the slant visibility" and numerous instruments and systems have been proposed to measure "slant visibility." Currently the FAA is studying the use of forward-scatter meters at heights of 10 and 100 feet in the approach zone, together with the

touchdown zone transmissometer for this purpose (12), and the Air Force is studying the application of laser type instruments. The FAA system is in the process of flight testing (13).

Surprisingly, even today there is no clear-cut agreement as to the meaning and purpose of slant visual range measurements. The following are examples of the concepts considered.

a) Measurement of slant visibility as a function of height.

In the broadest sense determination of slant visibility conditions is based on the assumption that the fog density does not change horizontally but does vary with height. The fog density is then determined as a function of height. Slant range can then be computed as a function of height. However, it is doubtful if a pilot could make use of a complete description of the slant visibility conditions as a function of height. More useful reports would be either the minimum slant visibility or preferably the minimum visual segment which would be encountered at a height below the decision height or the lowest height at which the pilot would see a minimum visual segment (ALCH).

b) The distance from the runway threshold at which the aiming point or threshold lights will be seen from the glide path.

This is an unsatisfactory criterion for use at airports since in a low visibility approach the pilot establishes his visual reference with the approach lights.

c) The distance from the threshold at which the approach lights are seen. Since the glide slope is about 3° , the glide path is very nearly parallel to the approach lights. Hence, when the visibility is so low that the outer lights of the approach light system cannot be seen, small changes in the height of the aircraft and in the downward angle of view from the cockpit will produce enough changes in the distance at which the approach lights are first seen.

d) The height at which the pilot will first see the approach lights. This criterion was tested briefly at the Landing Aids Experiment Station and was studied extensively during the AMB Newark tests. The criterion is applicable for conditions where the fog density increases or does not change with height. Under these conditions the visual segment increases as the height of the aircraft decreases. However, some modification and extension is required to make the concept applicable to very shallow fogs or to fogs in which the fog density decreases rapidly with height.

In considering the purpose of slant visual range measurements, it should be noted that the pilot, himself, makes an observation of the slant visual range when he reaches his decision height from the correct location and at the correct time for his particular approach. Thus, under present procedures, the purpose of any other assessment of slant visual range is to forecast what the pilot will see.

REFERENCES

1. Laufer, M.K. and Foskett, L.W., The daytime measurements of closed height; J. of the Aeronautical Sciences 8, 183 (1941).
2. Weather Bureau/Air Navigation Development Board, Final approach visibility studies, Fiscal Year 1952 Progress Report, Part 1; Washington, June 1952.
3. Weather Bureau/Air Navigation Development Board, Final approach visibility studies, Final Report; Washington, April 1955.
4. George, D.H., Evaluation of a Sperry lidar ceilometer; FAA-RD-74-23, 1974.
5. Moroz, E.Y., and Travers, G.A., Measurement of cloud height, Evaluation of ranging and triangulation techniques for determination of cloud height at airfields; AFC RL-RT-75-0306, May 1975.
6. Douglas, C.A. and Young, L.L., Development of a transmissometer for determining visual range; CAA Technical Development Report No. 47, Feb. 1945.
7. World Meteorological Organization, Guide to Meteorological Instrument and Observing Practices, Chapter 9 Measurements of Visibility; 1950 (with 1955 Supplement).
8. George, D.H., and Lefkowitz, M., A new concept: Sensor equivalent visibility; Inter. Conference on Aerospace and Aeronautical Meteorology, Washington, 1972.
9. Muench, H.S., Moroz, E.Y., and Jacobs, L.P., Development and calibration of a forward scatter visibility meter; AFC RL-TR-74-0145.
10. Chisholm, D.A., Objective predictions of mesoscale variations of sensor equivalent visibility during advective situations; AFGL-TR-76-0132.
11. Lefkowitz, M. and Schlatter, E.E., An analysis of runway visual range; FAA Report RD-66-100, Dec. 1966.
12. Naval Ammunition Depot, Slant visual range (SVR)/ approach light contact height (ALCH) measurement system, Evaluation in fog; Final Report Phase II; FAA Report RD-74-7.
13. McManus, R.G., et al, Slant range visibility measuring lidar; AFGL-TR-76-0262.

N79-17420

Lightning Hazards to Aircraft

Maj Philip B. Corn

Air Force Flight Dynamics Laboratory

I appreciate this chance to talk with you today about lightning hazards to aircraft. In fact I want to be somewhat more general and include aircraft static electricity, which can cause effects similar to those of lightning, and occasionally more insidious. I will present a brief overview of these "atmospheric electricity hazards" to aircraft and their systems, with emphasis on electrical and electronic subsystems. This will include first a look at some of the characteristics of lightning and static electrification, trends in weather and lightning-related mishaps, some specific threat mechanisms and susceptible aircraft subsystems, and some of the present technology gaps. Finally, I'll discuss a roadmap that we think shows how to get from where we are to where we need to be.

First, I should extend this preface to mention that since 1975 the Flight Dynamics Laboratory (AFFDL/FES) has been the Air Force's focal point laboratory for research into atmospheric electricity hazards protection (AEHP) of aircraft. We work closely with the Aeronautical Systems Division, the corresponding Air Force Point for AEHP engineering development. Moreover, in recent years we have found that many of our specific concerns and AEHP research goals correspond closely with those of NASA, FAA and NOAA, as I hope will be evident in what follows.

Table 1 lists some of the characteristics of lightning relevant to interactions with aircraft. Lightning is an extremely energetic electrical discharge occurring mostly within or between clouds, and with some fraction from cloud to ground. Very high electrical potentials, currents and energies are projected over long distances. Most of the energy is concentrated in the kilohertz region of the spectrum, although storms generating lightning also frequently produce considerable microwave energy in the processes occurring between the discrete strokes comprising a lightning flash. If an aircraft intercepts such a direct lightning strike, the high peak currents and longer continuing currents can cause distortion, burning and pitting of metal structures, penetration of thin skins, destruction of unprotected nonmetallic components such as fiberglass wingtips or radomes, and possible conduction of damaging, high currents into the aircraft interior. Various means of protection against these "direct effects" have been devised and documented [References 1-6]. However, there are "indirect effects" such as voltages induced inside aircraft components and subsystems by the rapidly changing skin currents and associated fields which

TABLE 1 - LIGHTNING CHA. PERISTICS

ELECTRICAL

- TYPES-Intra/inter-cloud, cloud-ground, positive, negative
- POTENTIAL-30-100 million volts
- CURRENT-20-200 thousand amps
- POWER- 10^{13} watts
- ENERGY- 5×10^8 joules nominal (200 lb TNT equivalent)
- EXTENT-3-30 km/stroke
- SPECTRUM-Peak energy near 10KHz, some above 10Mhz
- DURATION-
 - STROKE- 100 micro sec
 - FLASH- 0.2 sec (1-20 strokes)

OCCURRENCE/EFFECTS

- Worldwide phenomenon; 100 flashes/sec average; activity varies with climate, season, hour, location altitude. Turbulence correlated with lightning activity.
- Aircraft penetration through high electric field may trigger lightning strike. Two or more attachment points for each strike.
- Commercial airline data-about one direct strike per aircraft annually, many nearby strikes.
- Air Force data-fewer strikes shown than commercial due to mission profiles, avoidance, reporting procedures. Much greater strike frequency in European Theatre due to greater activity and route constraints. During 1970-1975 USAF aircraft dollar value losses averaged \$1.2M/year. Upward trend evident.

are much less well understood. These indirect effects may generate voltage transients of hundreds or thousands of volts' magnitude and can constitute a potentially serious threat to aircraft electrical or electronic systems. An airborne measurement program conducted jointly by Stanford Research Institute, AFFDL and NASA during the summer 1976 TRIP-76 research program at Kennedy Space Center also found similarly that measurable induced effects were produced by nearby lightning strikes. Finally, as is well known, static electrification can produce somewhat similar, though long duration, effects due to corona discharge. Aircraft charging processes occurring in precipitation can cause potentials of 50 kilo-volts or more which initiate such discharges from aircraft extremities or installed dischargers.

Figure 1 and Table 2 summarize recent Air Force experience with weather mishaps and give ascribed causes. A steady trend is evident amounting to an increase in mishap rate by a factor of three over a period of six years. I believe the trends in general aviation and air carrier rates show similar directions. The high rate of implication and cost for lightning appear significant. Although it's unlikely that lightning activity has been increasing steadily over this period, apparently the exposure of sensitive systems to weather threats and to lightning in particular has been increasing. I am confident there are many in this audience who can speculate with some authority on causes for these trends.

Table 3 lists a rather full selection of atmospheric electricity hazards, causes, and associated criticality. Virtually any of these hazards can under foreseeable circumstances result in aircraft loss or loss of life, and probably has.

Fully half of these hazards relate to effects on electrical or electronic systems. I believe it's worth pointing out, as was done at last year's workshop, that interruption of a critical, multiple redundant electronic control system by high level lightning-induced electrical transients could simultaneously defeat all channels of a system designed to protect against random, single channel failure. Another point of interest is the possible effect of lightning-generated acoustic shock; apparently the majority of lightning energy is transmitted through this mechanism.

Figure 2 illustrates the large number of potentially susceptible subsystems employed on a modern aircraft. Although the example shown is a military airframe, and one of the more exhaustively tested at that, the majority of these subsystems are employed by modern general aviation and air transport aircraft. Indeed, most of these subsystems have sophisticated microelectronic replacements with improved capabilities and greater inherent sensitivity to transients now on the drawing board or breadboard.

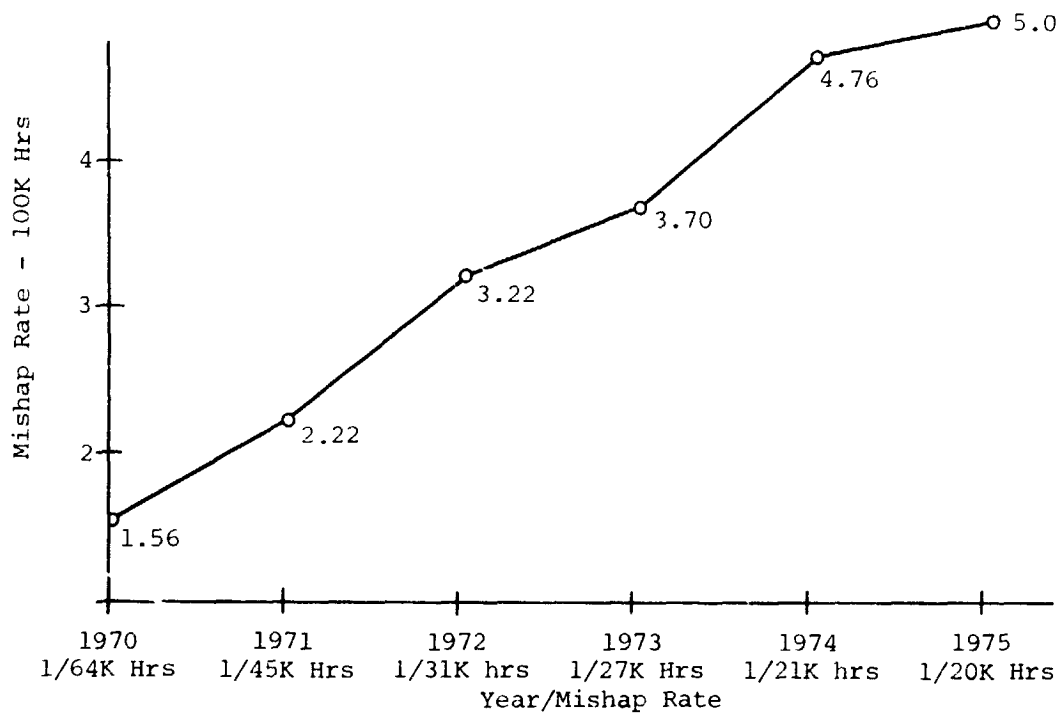

Figure 1 USAF WEATHER RELATED MISHAPS, 1970-75

TABLE 2

CAUSES AND COSTS OF USAF WEATHER MISHAPS, 1970-75

<u>Causes %*</u>	<u>Resources (K)</u>	
Lightning	55	7300
Hail	9	200
Icing	8	7800
Turbulence	8	63
Rain	5	20
Other	15	

*69% Enroute
31% Climb/Descent/Landing

TABLE 3 - ATMOSPHERIC ELECTRICITY THREATS TO AIRCRAFT

<u>Hazard</u>	<u>Cause</u>	<u>Hazard Criticality</u>
Malfunction/failure of electronic control systems	Low tolerance to electrical transients caused by direct/induced lightning or static electrification effects. May simultaneously affect parallel "redundant" systems.	Minor to catastrophic
Fuel tank explosion/fire	Fuel vapor ignition caused by static electricity or lightning effects.	Serious to catastrophic
Loss of engine	Possible lightning acoustic shock at engine inlet, or electrical transient effects on engine controls.	Serious
Prerelease/ignition of external stores	Premature activation caused by lightning or static electrification effects.	Serious to catastrophic
Radome, canopy, and windshield damage	Direct lightning strikes; arc discharge caused by static electricity buildup.	Minor to serious
Instrumentation problems/communications, navigation & landing system interference	Transient effects caused by static electricity buildup & direct & nearby lightning strikes.	Minor to catastrophic
Structural damage	Direct lightning attachment to aircraft	Minor to serious
Physiological effects on crew	Flash blindness & distracting or disabling electrical shock caused by direct & nearby lightning strikes.	Minor to catastrophic

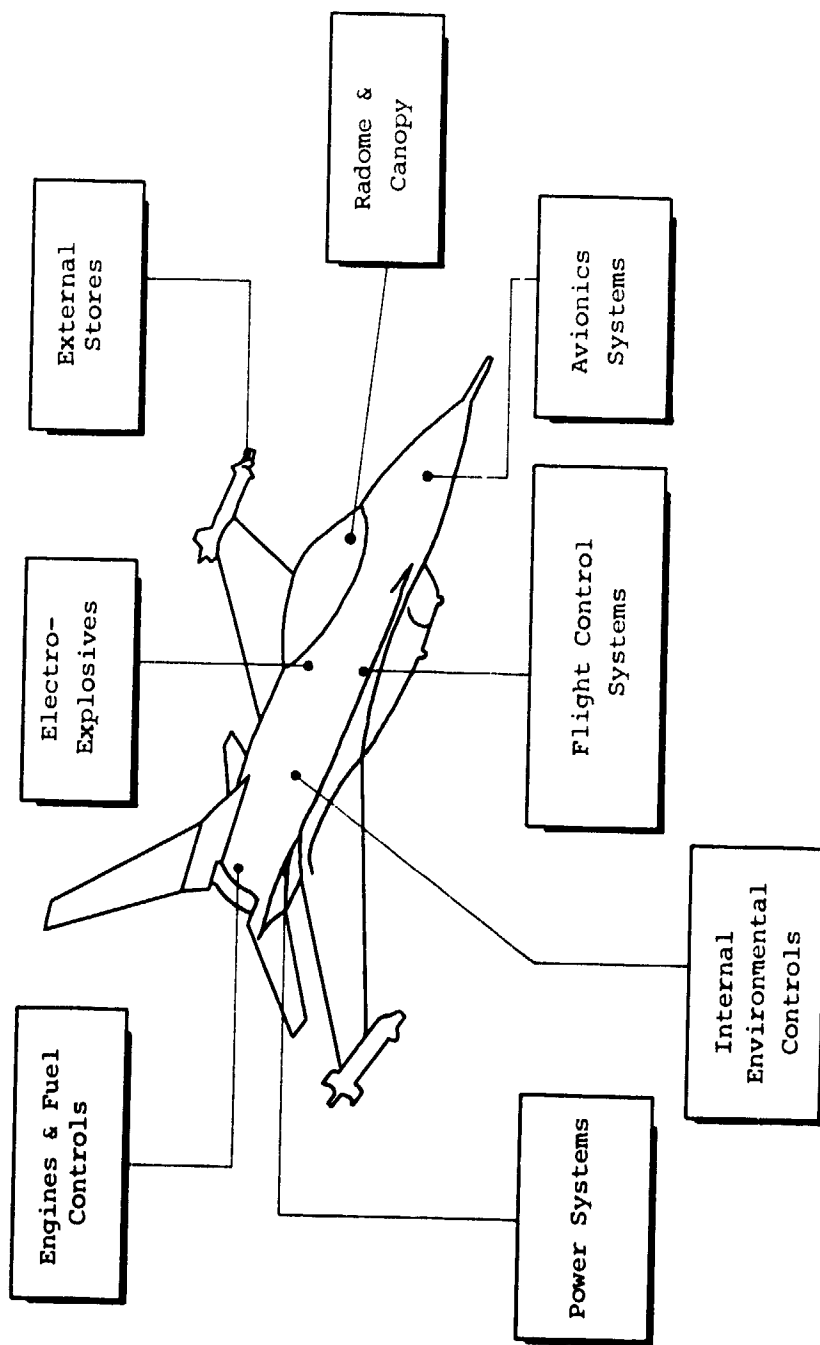

Figure 2 SYSTEMS SUSCEPTIBLE TO ATMOSPHERIC ELECTRICITY HAZARDS

In this review of hazards and susceptible systems a recurring theme of concern for protection of microelectronic circuitry has sounded. These devices offer very considerable promise of greatly expanded control flexibility and improved systems performance, safety and efficiency. However, the low operating voltages and power handling capabilities of integrated circuitry, particularly large scale integrated (LSI) circuits, also make them inherently susceptible to induced transients. Similarly, the introduction of advanced aircraft structures with their very different and unfamiliar electrical and radiation shielding properties requires considerable care to assure enclosed subsystems are fully protected. On the other hand, excessive protection measures can impose severe cost and weight penalties, cancelling the original benefits from these new technologies. The answer is to produce design criteria and guides for optimum protection of these systems in advanced airframes and structures.

The road between here and there unfortunately has some gaps which are shown in Table 4. Leading the list is the requirement for accurate, high resolution, realistic measurements of the lightning environment. To achieve the necessary confidence and detail these measurements should be taken from an airborne platform, with confirming and amplifying ground measurement, if possible. Incident electromagnetic fields, skin currents and induced voltages are required for both nearby and direct strikes, with enough measurement data points to establish required confidence levels on the measured variations. Enough measurements have been taken to establish the feasibility and desirability of such a program, and to define the order of magnitude of expected effects. In addition, static electrification measurements are required, and the effectiveness of ground and airborne lightning avoidance systems should be established. Tested analytical models of the aircraft interaction with nearby and direct lightning and with static electrification, and validated qualification testing of various types are also required. For both of these capabilities, which now exist in preliminary form, the natural lightning parameters must be provided at the front end. The question therefore returns to environmental measurements as the first priority. We have proposed a joint program with Air Weather Service and NASA/LARC on a Hurricane Hunter aircraft and are investigating possible programs with NOAA/ERL/NSSL to obtain these measurements.

The Technology Roadmap shown in Figure 3 conveys the picture put together by an interlaboratory working group to chart the necessary steps and directions to the goal of AEHP design criteria, guidelines and specifications. The program defined by this map is a large, multi-year effort of which we now occupy only the beginning phase. Work is underway in each of the areas identified in the left-most blocks, and in development of assessment methodology, both via

TABLE 4

ATMOSPHERIC ELECTRICITY HAZARDS PROTECTION
TECHNOLOGY GAPS

- Environmental Threat Assessment
 - Airborne Measurements of Lightning (Nearby and Direct Attachment)
 - ambient EM fields (waveform, peak values, spectra)
 - skin currents (peak values, spectra, distribution on A/C)
 - induced voltage transients in circuitry
 - EM fields within A/C
 - large enough data base to derive threat statistics (2-300 samples give 99 percentile values to 90% confidence)
 - confirming ground measurements
 - Airborne Measurements of Static Electrification
 - skin currents, induced transients
 - Effectiveness of Lightning Avoidance Techniques
- Analytic Modelling - Effects on Advanced A/C Systems/ Structures Due to
 - Lightning Attachment
 - Nearby Lightning
 - Static Electrification
- Validated Qualification Testing
 - Lightning Attachment, Current Impulse, Nearby Strike, Direct/Induced Effects
 - Static Electrification

EM HAZARDS TECHNOLOGY ROADMAP

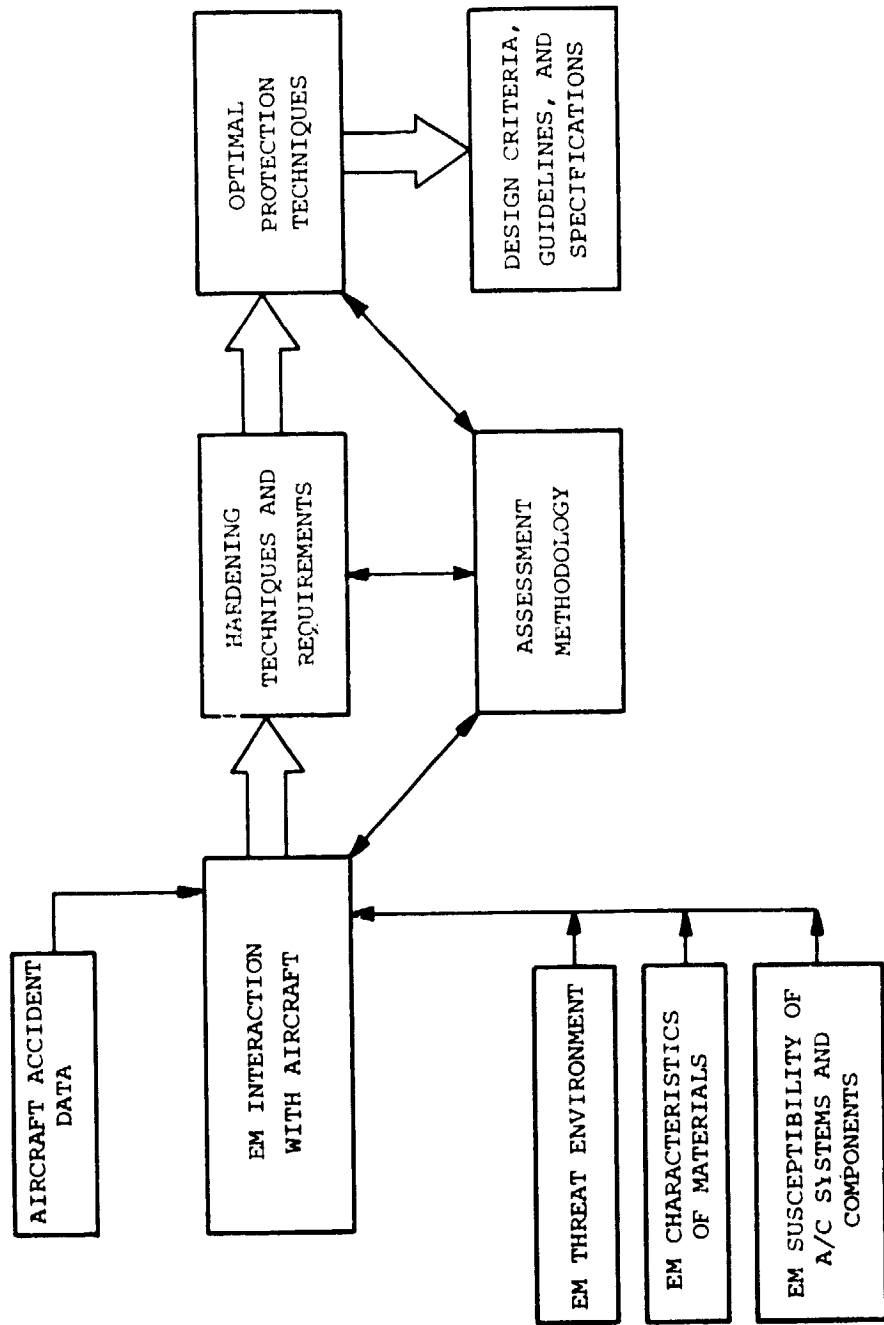

Figure 3

analytical efforts and experimental testing. The analytic efforts, which are aimed at developing the ability to predict transients on aircraft circuitry from given or measured aircraft skin current distributions, and ultimately from more general specifications, have taken three different approaches. In the first, a model for the lightning interaction was developed from first principles. In the second approach, an existing model developed by the Air Force Weapons Laboratory for the nuclear electromagnetic pulse (NEMP) problem, a related interaction, was modified for lightning use. In the third, undertaken by Naval Air Systems Command, a development of the Intrasystem Electromagnetic Compatibility Analysis Program (IEMCAP), a large scale EMC model, has been used. At least several of these appear promising, but none has as yet been validated. Experimental testing development has pursued the direction set by the Lightning Transient Analysis test several years ago. A laboratory in-house and contracted effort over several years' time, employing the original developer of the technique, has refined and extended this procedure for measuring impulse-induced electrical transients, and has placed it on a much improved theoretical and practical base.

One original intent of this Roadmap effort was to provide the means for concerned laboratories and agencies to define their proper part in an integrated program. I believe insofar as we are all committed to continued and improved flight safety for the current and coming generations of aircraft which will encounter the inevitable natural hazards of atmospheric electricity, we must ask ourselves what part of this effort may be ours.

REFERENCES

- 1 . Chalmers, A.J., Atmospheric Electricity, Pergamon, 1965.
- 2 . Uman, M.A., Lightning, McGraw-Hill, 1969.
- 3 . Cianos, N. and Pierce, E.T., "Ground Lightning Environment for Engineering Usage," Technical Report 1, Contract L.S.-2817A3, SRI Project 1834 for McDonnell Douglas Astronautics Corp., Stanford Research Institute, Menlo Park, CA (August 1972).
- 4 . Nanevicz, J.E., Adamo, R.C. and Bly, R.T., Jr., "Airborne Measurement of Electromagnetic Environment Near Thunderstorm Cells (TRIP-76)," Technical Report, Contract NAS9-15101, SRI Project 5536 for NASA/JSC and USAF/AFFDL(FES), Stanford Research Institute, Menlo Park, CA (March 1977).
- 5 . Fisher, F.A. and Plumer, J.A., "Lightning Protection of Aircraft," NASA RP 1008, 1977.
- 6 . Golde, R.H. (ed), Lightning, Academic Press, 1977 (2 Vol.)



SECTION V
SHORT
PRESENTATIONS



**ORIGINAL PAGE IS
OF POOR QUALITY**

Helicopter Icing Research

Richard I. Adams

U.S. Army Research and Technology Laboratories

When Dr. Frost invited me to chair the Aircraft Icing Committee during this meeting, I was in Spokane, Washington, participating in flight test experiments with ice-phobic coatings applied to helicopter rotor blades. When he learned that the test program was revealing limited positive results, he requested me to brief the workshop on results of the program. The purpose of this presentation is to do just that, but first it seems appropriate to give you an overview of the Applied Technology Laboratory helicopter icing R&D program.

The objectives of our program are outlined in Table 1. Our objectives have been to establish accurate design and test criteria for helicopters and to assure that technology will be available to satisfy requirements. As in any R&D programs, where possible, our approach is to attain our objectives in a manner that will allow application of results to current helicopters.

Table 1
OBJECTIVES

- Primary
 - Accurate design and test criteria for each future generation Army VTOL aircraft
 - Assure technology will be available to satisfy requirements
- Secondary
 - Technology spin-off applicable to current fleet

Before we proceed with technology developments, we wanted to assure ourselves that any technology-related work was aimed at accurate design criteria. The result of this initial effort is shown in the next three figures. In Figure 1, design criteria were established for supercooled clouds. The upper curve relates to the continuous maximum condition and the lower curve relates to the intermittent maximum condition. As you may know, these criteria are very similar to those in the FAR 25 with the exception of the lower temperature limit that goes to -22°F in FAR 25, and the upper liquid water content limit that goes to three grams per cubic meter for the intermittent maximum condition. The criteria for supercooled clouds that we have developed are not as

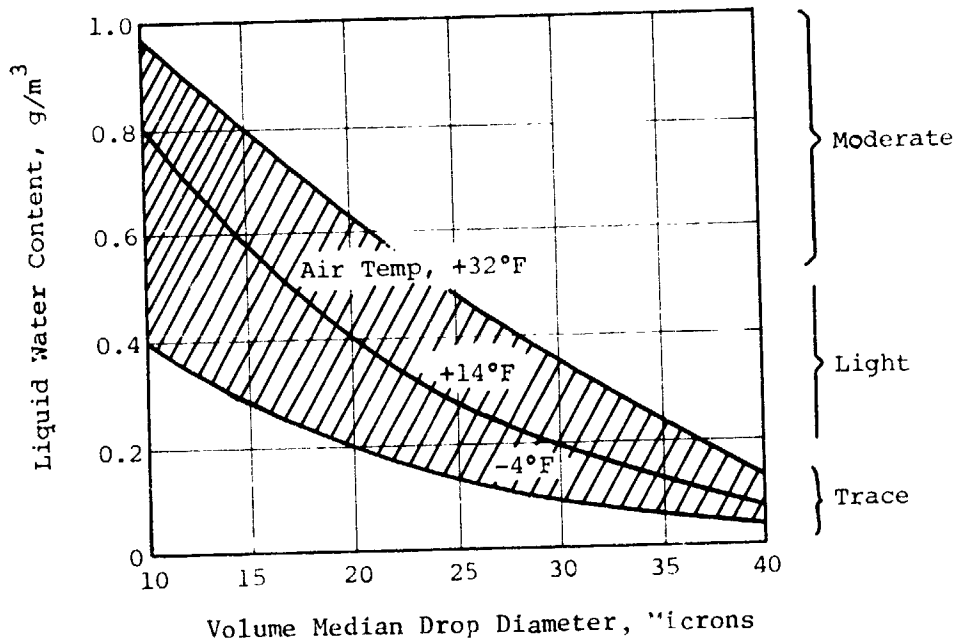

(a) Continuous maximum (Stratiform Clouds)

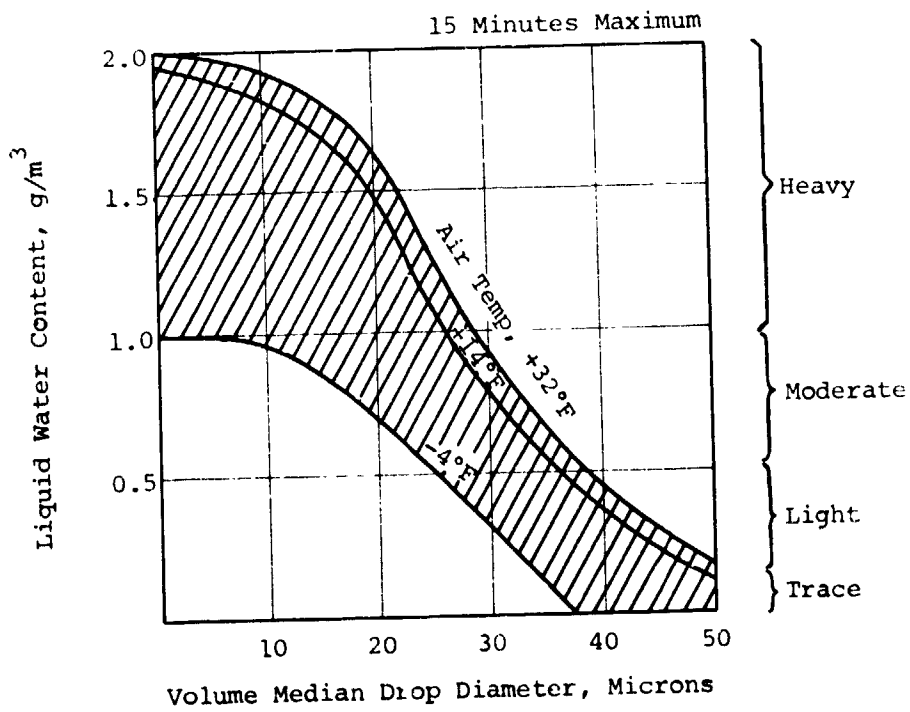

(b) Intermittent Maximum (Cumuliform Clouds)

Figure 1 Recommended Atmospheric Icing Criterion

constraining and we feel that, for the Army helicopter, they should not be as stringent as that for aircraft that normally operate at higher altitudes. These criteria represent the 99th percentile of exceedance probability for altitudes up to 10,000 feet, the normal altitude range of Army helicopters. Along the right side of these curves you will notice that we have related the subjective terms "trace," "light," "moderate," and "heavy" to liquid water content ranges. We are suggesting that the subjective terms be dropped altogether; however, we have selected this relationship based upon our best judgment of what these terms should mean. Design criteria for snowfall and freezing rain, developed under our program, are shown in Figures 2 and 3.

Once we were confident that we had adequate meteorological design criteria for helicopter ice protection systems, we set about to examine the technology. This technology assessment concluded that technology was basically in hand to satisfy the ice protection requirements of all helicopter components except for rotor blades. Our effort was, therefore, concentrated in that area. Table 2 lists the various concepts examined for rotor blade ice protection. Results of analyses of these various concepts concluded that the electrothermal, cyclic deicing concept showed the most promise of satisfactorily meeting the needs. We selected the spanwise shedding concept for development and flight test purposes.

Table 2
Blade Ice Protection Concepts

- Electrothermal
- Bleed air
- Heated liquid
- Chemical freezing point depressant
- Mechanical pneumatic (boots)
- Ice-phobic materials
- Electro impulse
- Sonic pulse

Figure 4 shows a photograph of the resulting research helicopter hovering in the Ottawa Spray Rig. This icing research helicopter is equipped with ice-protected main and tail rotor blades, using the spanwise shedding concept developed under our program, heated glass windshields, a modified FM whip antenna, two experimental ice detectors that provide signals for control of the rotor ice protection system and for cockpit display of cloud liquid water content, an anti-iced main rotor stabilizer bar, and a complete instrumentation system. The

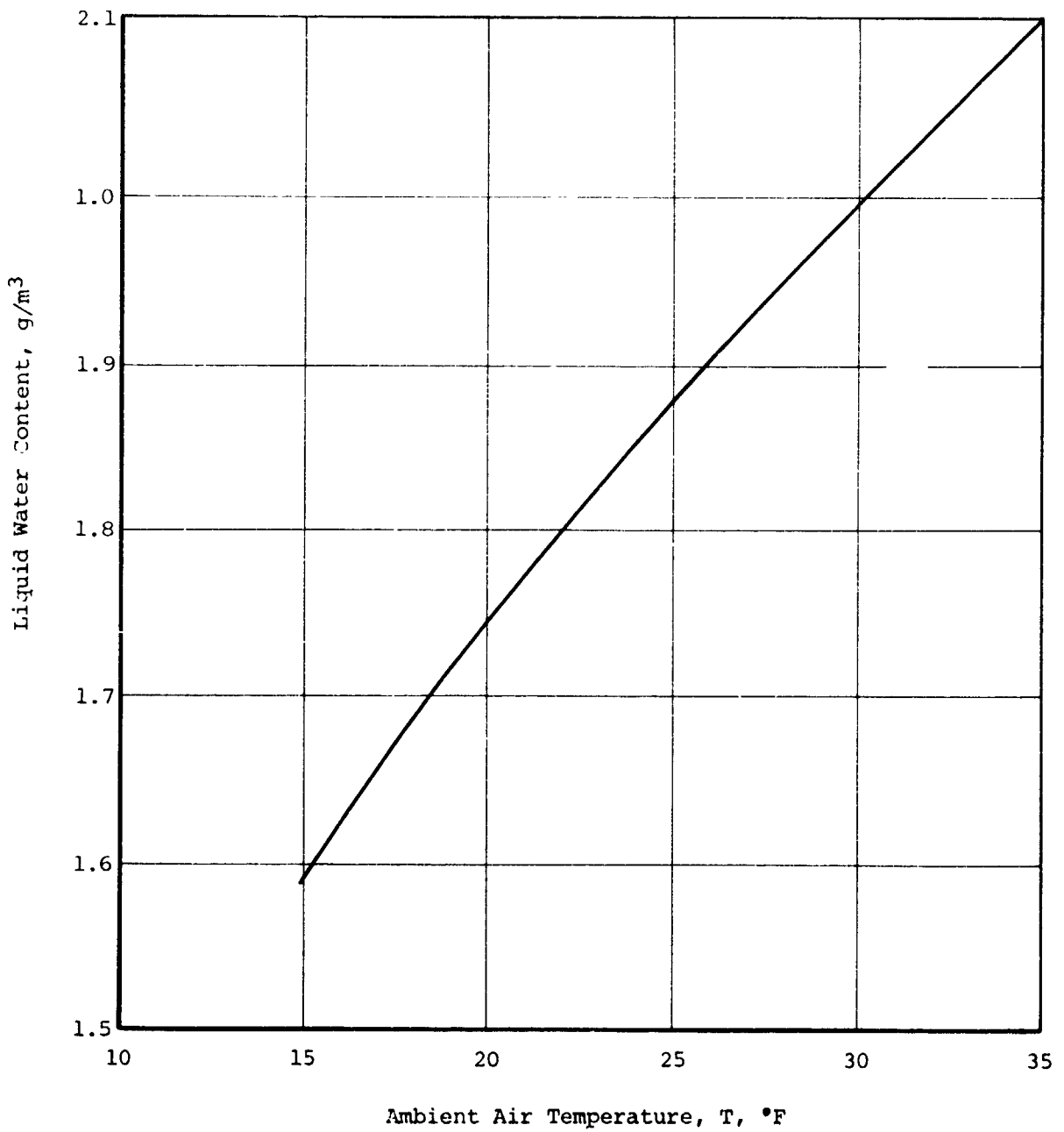

Figure 2 Worldwide Maximum Snowfall Liquid Water Criteria - 99 th Percentile Conditions

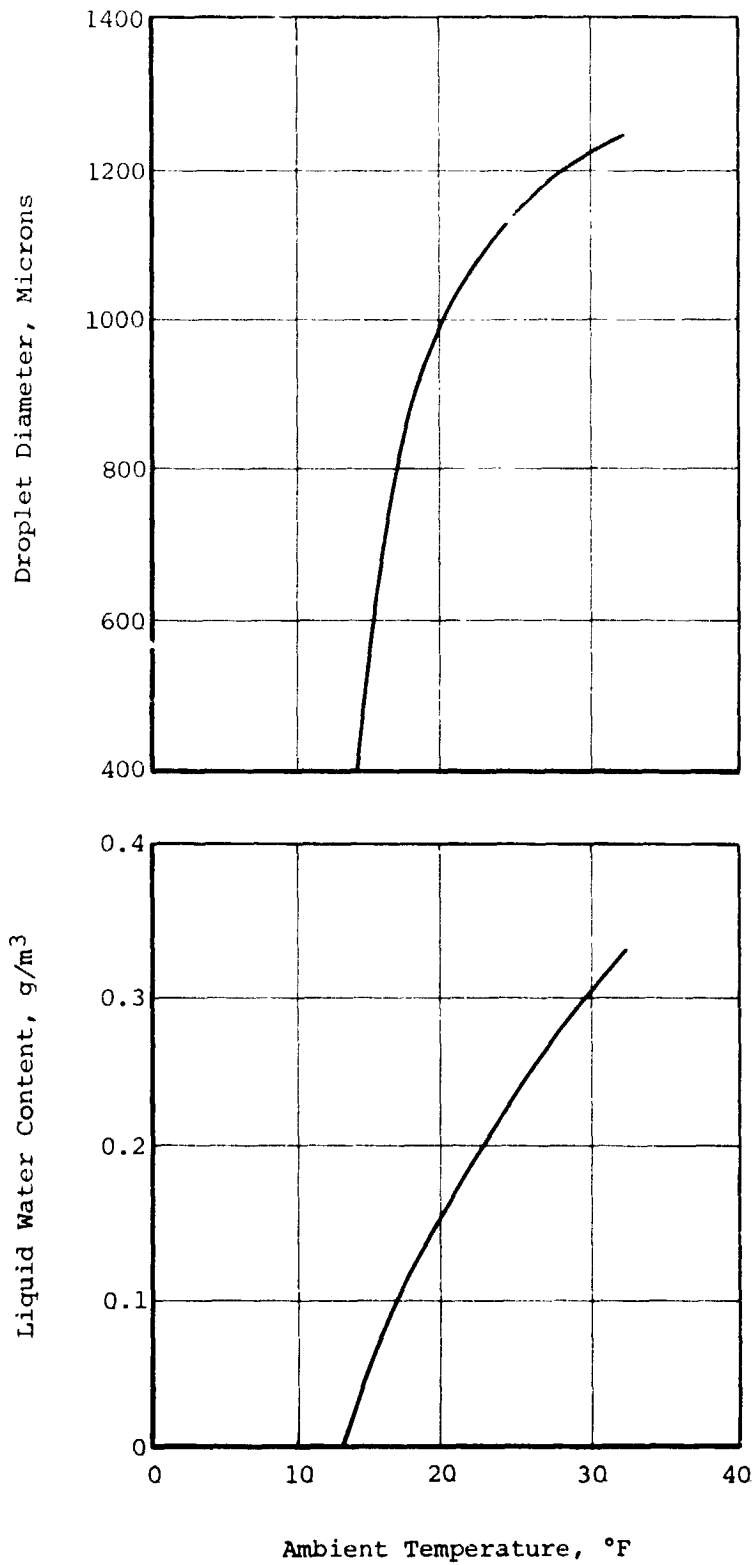

Figure 3 Freezing Rain Severity Levels - 99th Percentile Conditions



Figure 4 UH-1H HOVERING IN OTTAWA SPRAY RIG

instrumentation system includes a hub-mounted camera for photographic coverage of ice accumulations, shedding and runback, and an integrating rate unit (IRU) that integrates liquid water content as a function of time to allow very precise natural icing severity level envelope expansion.

Figure 5 shows a photograph of the Sikorsky BLACKHAWK under simulated icing tests behind the USAAEFA Helicopter Icing Spray System (HISS). This is a CH-47 modified to incorporate a 2,500-gallon water tank and the retractable spray boom. Our experimental UH-1H used the HISS for simulated icing tests.

The objectives of our flight test program are outlined in Table 3. First, to demonstrate the feasibility of the spanwise shedding concept over the range of design criteria under both simulated and natural icing conditions; to explore the effects of ice accretion and shedding on vibration, loads, performance, stability, and control; to explore the criticality of system control parameters, e.g., energy on-time, power density, and the ice detector function; to explore the effects of the engine exhaust IR suppressor upon tail rotor heating; to explore the icing characteristics of unprotected components of the helicopter; and to explore the effects of rotor blade ice protection system failure, incomplete shedding and runback. Further, we wanted to try to establish a correlation between simulated and natural icing test techniques and to ultimately develop an icing research test bed helicopter.

Table 3
UH-1H Simulated & Natural Icing Test
Objectives

- Demonstrate ~ Feasibility of Spanwise Shedding Concept
 - Over range of design criteria
 - Under simulated & natural icing conditions
- Explore ~
 - Effects of ice accretion & shedding upon
 - vibration, loads
 - performance, stability & control
 - System control parameter requirements
 - on-time, off-time
 - power density
 - ice detector function
 - Effects of IR suppressor
 - Icing characteristics of unprotected components
 - Effects of system failure, incomplete shed, runback
- Correlate ~ Simulated & Natural Icing Test Results
- Develop ~ an Icing R&D Test Bed Helicopter



Figure 5 SIKORSKY BLACKHAWK UNDER SIMULATED ICING TESTS
BEHIND THE USAAEFA (CH-47) HELICOPTER ICING SPRAY
SYSTEM (HISS)

Table 4 shows a breakdown of the flight test hours accumulated to date. A total of 63 hours of productive flight test time during airworthiness testing conducted in 1975, HISS testing conducted at Moses Lake, Washington in March 1975, Ottawa Spray Rig testing conducted in 1976, and Natural icing tests combined with additional Ottawa Spray Rig tests conducted in 1977. This chart does not reflect the 34 flight test hours accumulated during another test program just completed in Ottawa yesterday. The test team is now in the process of packing up and coming home.

Table 4
Ice-Protected UH-1H
Flight Testing Summary

<u>Event</u>	<u>Hours</u>
Ground Testing	9.9
Airworthiness Flight Testing	10.8
HISS Productive	15.8
HISS In-Cloud	2.7
Ottawa Spray Rig Productive	30.8
Ottawa Spray Rig In-Cloud	10.3
Natural Icing Productive	16.7
Natural Icing In-Cloud	5.3
 Total HISS Tests	 12
Total Ottawa Spray Rig Tests	21
Total Natural Icing Sorties	10
 TOTAL PRODUCTIVE FLIGHT TIME	 63.3 Hrs.

Figure 6 shows the various test points we had hit during the flight test program. This is a cross plot of the design criteria presented earlier for supercooled clouds holding droplet-size constant at 15 microns. For that droplet size, liquid water content is plotted versus ambient temperature. The black dots indicate the natural icing test points hit to date. Eleven more points were obtained this winter.

Some of the basic results of the studies performed earlier in the program are listed in Table 5. Because of the estimated weight penalty for existing helicopters, the Army users have been reluctant to state a solid requirement for ice protection on existing helicopters. For example, the estimated weight for equipping the UH-1H

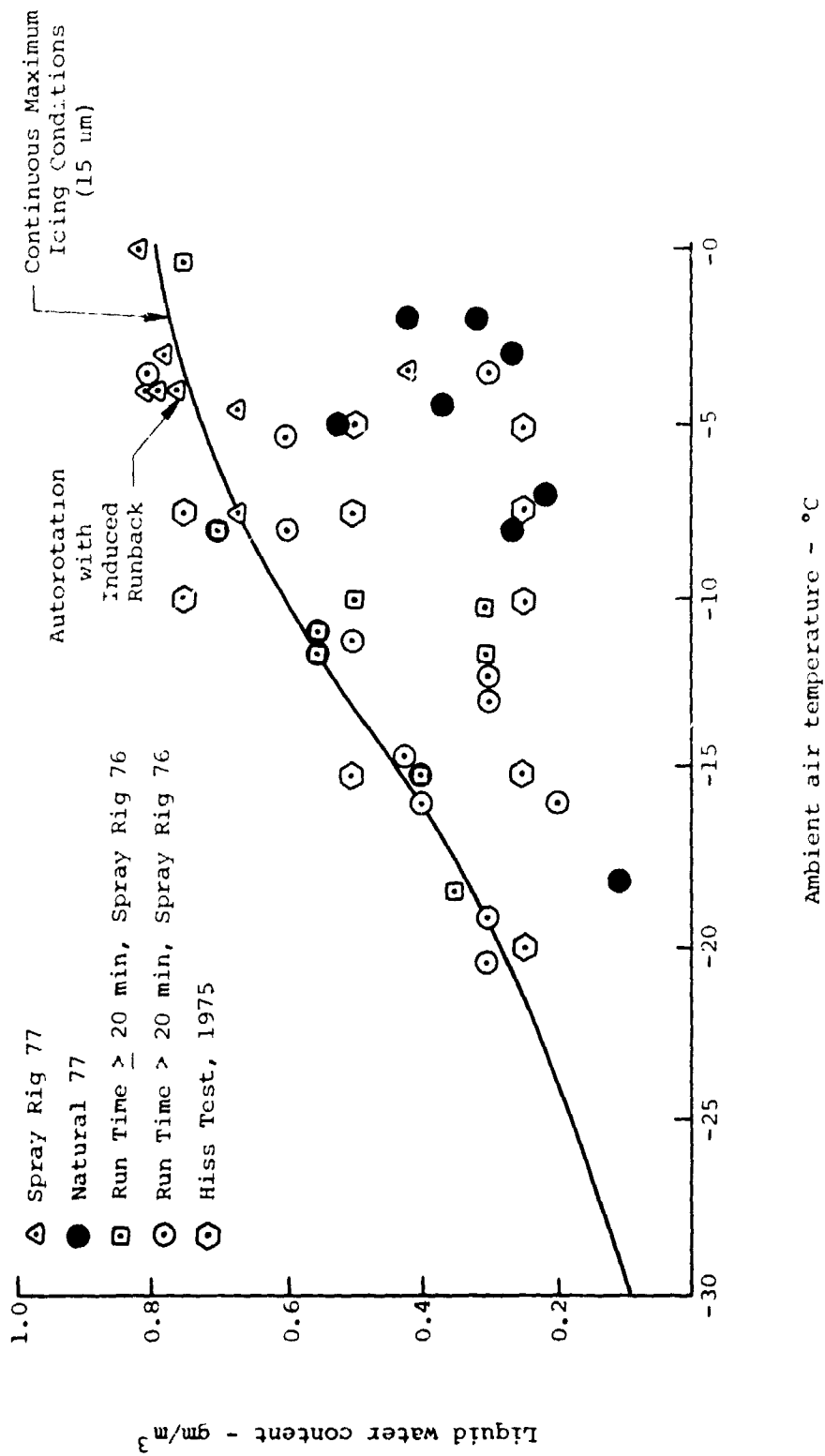

Figure 6 Simulated and Natural Icing Points

with complete ice protection, made in 1974, was 165 pounds. This would mean off-loading one troop from the troop transport mission. Because of this, we began looking for other, lighter weight concepts for rotor blade ice protection. A list of the concepts shows promise for cost effective application, but funding is not currently available to further pursue them.

Table 5
Estimated Penalties for Helicopter Ice Protection

	<u>Existing</u>	<u>Future</u>
Empty Weight	2 - 4%EW	1.0 - 1.5%EW
Engine Power (Peak)	40 - 160HP	40 - 160HP
ΔFuel Consumption	0.25%	0.25%
Reliability	as high as basic helicopter	
Maintainability	TBD	4MMH/1000FH
Cost - Recurring	\$28-\$82K/ship	\$25-\$45K/ship
- Nonrecurring	\$2.5-\$5.0M	\$1.0-\$1.5M

We have managed to take another look at ice-phobic coatings, and this is the program I would like to summarize for you very briefly.

As many of you know, NASA Lewis and FAA-NAFEC cooperated in an icing tunnel assessment of over a hundred candidate ice-phobic coatings in the 1960's. A report was published by Don Miller in 1968. None of the coatings were found suitable for aircraft applications although many were found to reduce adhesion force of ice to the test sample. These tests were conducted in the NASA Lewis icing tunnel. In 1974, we decided that since the time frame of the NASA-FAA test program, other substances might be available that could reduce adhesion force sufficiently for application to helicopter rotor blades. We issued an advertisement in Commerce Business Daily and received about 20 replies. Of the replies received, we selected six substances for laboratory test. Two of the samples had been tested during the NASA-FAA program. We selected these because the adhesion force of these substances was found to be low, and we needed correlation between our test technique and the NASA-FAA test technique.

The results of testing conducted by the U.S. Army Cold Regions Research and Engineering Laboratory, Hanover, New Hampshire, are shown in Figure 7.

This is a plot of average shear force required to dislodge the ice from the test sample versus successive or repeated tests or ablation tests. You can see that most of the substances produce very

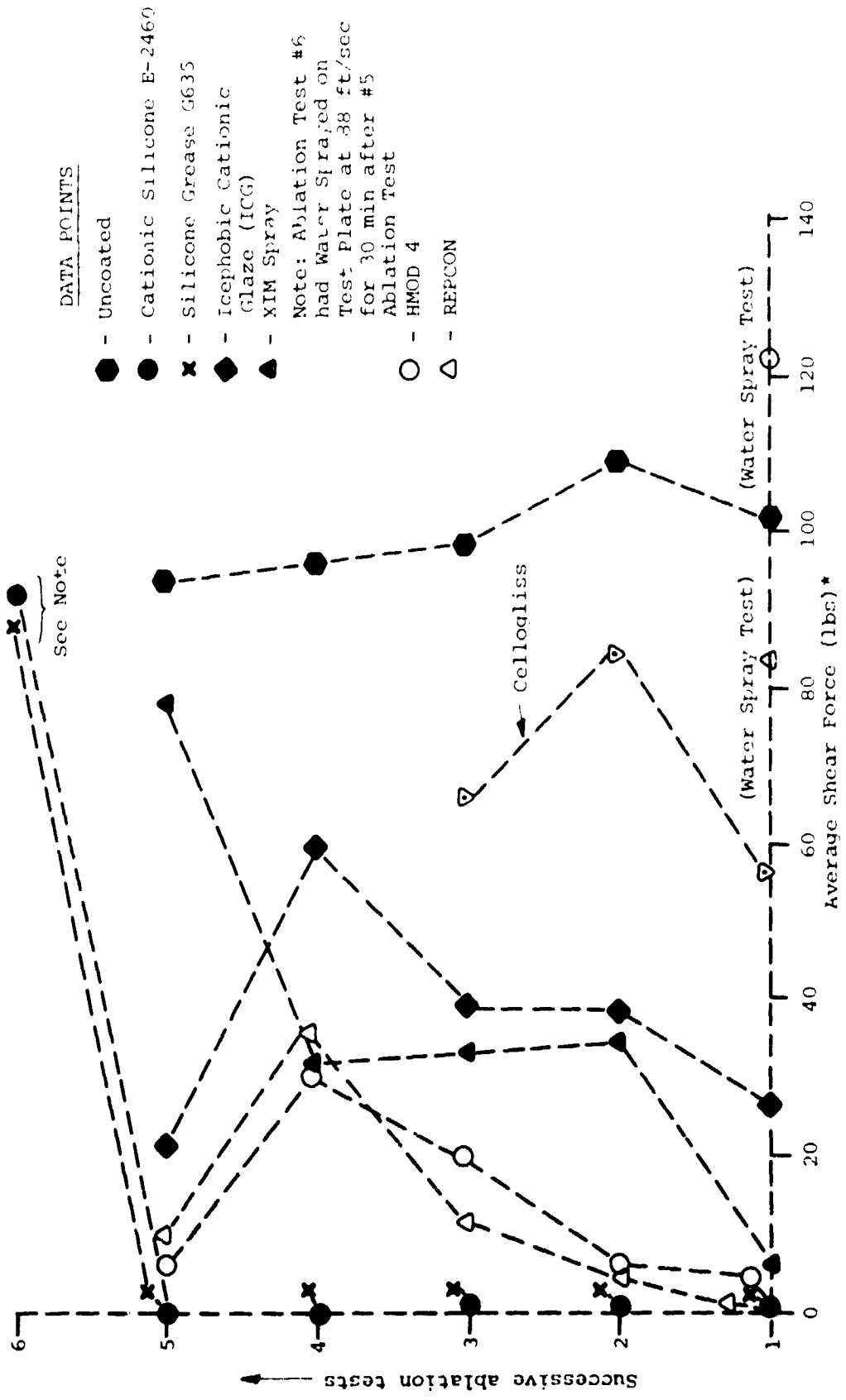

Figure 7 TESTING CONDUCTED BY U.S. ARMY COLD REGIONS RESEARCH AND ENGINEERING LABORATORY

erratic results and that the adhesion force is fairly high. The curve on the right side of the chart is the baseline, uncoated test sample. Two coatings, however, showed very low adhesion force repeatedly, as can be seen on the left side of the chart. This was true until the test samples were subjected to simulated rain tests. As you can see, the adhesion increased to the baseline value. These results, however, gave us hope that in the supercooled cloud environment, these coatings may have sufficient life to provide rotor blade protection. This winter, we were able to conduct a very limited flight test experiment to obtain data on the life and application techniques. These flight tests were conducted for ATL by USAAEFA from the Spokane International Airport and were completed in mid-February of this year.

Table 6 shows the basic results of the test program. Two coatings were tested. One was a silicone grease manufactured by the GE Silicone Products Division, Waterford, New York. The other was a silicone oil manufactured by the Dow Chemical Company. Both coatings showed promise, but the life of the Dow substance appeared better. This chart lists the life under the test conditions of the Dow substance.

Table 6
Ice-Phobic Flight Tests

- Two Materials Tested (Jan-Feb '78)
- HISS/UH-1H Tests
- Dow E-2460 Most Effective

-5°C; 0.25 g/m ³	>79 minutes
-5°C; 0.50 g/m ³	>60 minutes
-10°C; 0.25 g/m ³	>77 minutes
-10°C; 0.50 g/m ³	40 minutes (mild shed)
-15°C; 0.25 g/m ³	13 minutes (torque limit)
- Effects of Rain, Snow, and Dust, Etc. Unknown

The test procedure was to fly in the HISS cloud for brief intervals and then come out of the cloud and take a trim shot where engine torque changes were noted. From a safety standpoint, an engine torque pressure increase of five psi was assigned as a limit. We would repeat these cloud immersions and trim shots until torque limit or some other safety limit was reached.

As you can see from this chart, the Dow coating lasted up to an hour and seventeen minutes under the test conditions. For

comparison purposes, the Army almost lost a UH-1H during testing in Alaska in 1974. On that occasion, the UH-1H had been in the cloud at liquid water content of 0.25 gm/m^3 at -10°C for 22 minutes when most of the ice on one blade shed assymmetrically, causing very severe vibration and extreme difficulty on the part of the crew to recover and land the aircraft. So you can see that the Dow coating, under these test conditions, is performing as an ice-phobic coating. We did observe a mild assymmetric shed after 40 minutes at -10°C and 0.5 gm/m^3 and we reached the torque limit in 13 minutes at -15°C .

I want to emphasize that these tests were of very limited scope, but the results to date show that ice-phobics show promise for application to rotor blades and may provide at least a limited capability for flight in icing conditions where the LWC is less than 0.5 gm/m^3 and the ambient temperature is around -10°C . More testing is needed to determine the effects of rain, snow, dust, and other factors on coating performance. A program has been laid out for development and fielding kits for operational evaluation. I sincerely hope that we can quickly secure the funding to proceed with this and other promising concepts.

THE PREDICTION OF LIGHTNING-INDUCED VOLTAGES

N79-17422

ON METALLIC AND COMPOSITE AIRCRAFT

John Birken

NAVAIR/DOD

Aircraft must operate in a variety of electromagnetic environments which can be categorized as those emanating from friend, foe and natural phenomena. Natural phenomena are divided into the P-static formed by charge buildup accrued from atmospheric particles through which an airplane flies and lightning. Lightning is the most severe natural electromagnetic hazard commonly encountered by aircraft. During the period of 1965-74 more than 700 lightning-related incidents occurred to USAF aircraft. Reported lightning strikes to USAF aircraft averaged about 5 per 100,000 flight hours while U.S. commercial airline experiences indicated approximately 33 reported strikes per 100,000 flight hours. More strikes occur during climb and descent at altitudes below 12,000 feet. Historically most reported strikes to aircraft have not resulted in catastrophic damage, although both commercial and military aircraft have been reported lost as a result of lightning strikes.

Undesirable electromagnetic effects associated with lightning are manifested in two general ways: the high current effects due to a direct strike and the high field effects due to a near miss. Adverse high current effects are primarily physical damage and burnout of the aircraft structure. Resultant pitting/puncture points indicate the location of lightning entry or exit points on the aircraft. Radomes, pitot booms, canopies, external antennas and unprotected advanced composite structures are particularly vulnerable to lightning damage of this type. Adverse high field effects are primarily temporary disruptions and/or permanent damage to internal avionics. Earlier vacuum tube electronics were relatively immune to transients induced by lightning or other electromagnetic hazards. Recent technological progress from vacuum tube electronics to discrete solid state electronics and then to integrated circuits has led to increased sensitivity of on-board avionics to induced transients. Further trends are towards application of microcircuitry including large scale integrated circuits and microprocessors which will have increased sensitivity to induced electromagnetic effects. Lightning pulse wave form parameters include rise time, peak current, total transferred charge, peak electric and magnetic fields and the radiated field spectral distribution.

Various government agencies have put forth an effort to enable the prediction of what lightning current will do to aircraft avionics systems. Figure 1 illustrates ongoing and future efforts of predicting avionic voltages and currents caused by electromagnetic fields external to the aircraft. The Intrasystem Analysis Program known as IAP conceived by the Rand Corporation and developed by the Rome Air Development Center (RADC) has been put to use by the Naval Air Systems Command (NAVAIR) to predict lightning-induced voltages on avionic systems.

ELECTROMAGNETIC MANAGEMENT

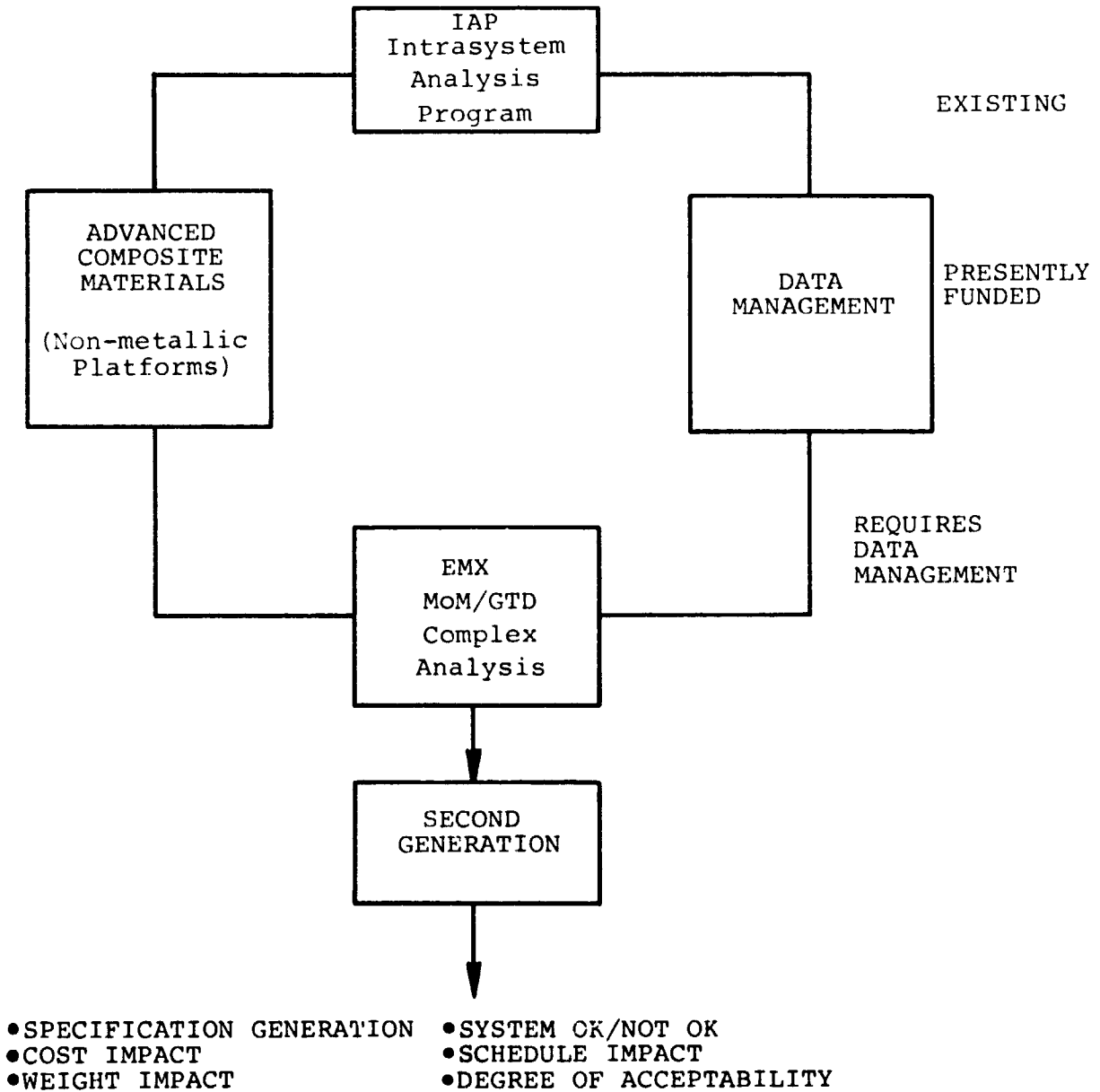

Figure 1

As Figure 1 shows, IAP is an existing program. Presently funded programs are investigating the modification non-metallic composite materials will cause to the metallic IAP program predictions. Naval Systems Command (NASC), Rome Development Center, and the Air Force Flight Dynamics Lab (AFFDL) are the primary groups involved in composite material investigations. These efforts concern determining the intrinsic properties, conducting permittivity and permeability of composite materials as a function of frequency. From these intermediate terms of magnetic and electronic shielding as a function of frequency, it is indicated that composite materials are more susceptible to lightning. In addition, presently funded programs are developing data management tools to better utilize the IAP program output. Also in development is the EMX program where X implies any of the many electromagnetic disciplines. The EMX program deals with very complex problems such as 50 antennas located on one mast. The solution of these complex problems requires sophisticated moment method techniques (MOM) and geometrical theory of diffraction (GTD) techniques. NAVAIR is concentrating on adapting the existing metallic programs and modifying them for application to composite materials.

At present a first generation program exists which indicates that the avionic system is OK/not OK, the avionic systems interference to signal ratio and a means of specification generation. The second generation program will increase cost impact, schedule impact, and weight impact. These impacts are penalties that are necessitated to counteract the lower shielding composites will offer. Does compensating for lower composite material shielding impose a cost impact? Cost impact will also answer if going forth to composites requires cost in excess of remaining with aluminum airframes. Likewise, problems can occur from existing composite data incompleteness while composite aircraft are being built. How this affects schedule or, more importantly, when, upon correcting for the characteristics, will the schedule be changed. Weight impact is a measure of the weight savings composites provide after shielding such as aluminum flame spray is added. Presently, the IAP program predicts whether the subsystem is OK/not OK and how OK or not OK the avionic subsystem is by providing the signal to interference ratio which is a measure of the degree of acceptability of the aircraft avionics.

The Navy has successfully applied the IAP program to predicting antenna-to-antenna interference problems on the S-3 and P-3 antisubmarine aircraft and F-14 and F-18 fighter aircraft. The Air Force has used IAP to predict F-15 aircraft problems. The F-15 data base is complete in having not just antenna-to-antenna bases but also wire-to-wire coupling data and field wire coupling data. The field-to-wire coupling algorithms are exercised to predict lightning effects on avionics. To this end, NAVAIR has put a limited amount of F-14 data as well as certain data for other aircraft into use which will be discussed later.

Figure 2 depicts an overview of the mechanisms which are required for the prediction of voltage induced on a wire by lightning. $D(j\omega)$, the spectral driving function, is diminished by $T_1(j\omega)$, the frequency dependent

$D(j\omega) * T_1(j\omega) * T_2(j\omega) * T_3(j\omega) * T_4(j\omega) * T_5(j\omega) = V_{ij}$
 THERMAL
 MATERIAL SHIELDING $\rho(j\omega)$ $\mu(j\omega)$ $\epsilon(j\omega)$ DEPENDENT
 AIRFRAME SHAPE INFLUENCE ON S_H, S_E
 COMPOSITE - METAL JOINT LEAKAGE
 CABLE TYPE
 SUBSYSTEM SUSCEPTABILITY
 VOLTAGE
 ACROSS
 SUBSYSTEM
 $V_{ij}(j\omega)$

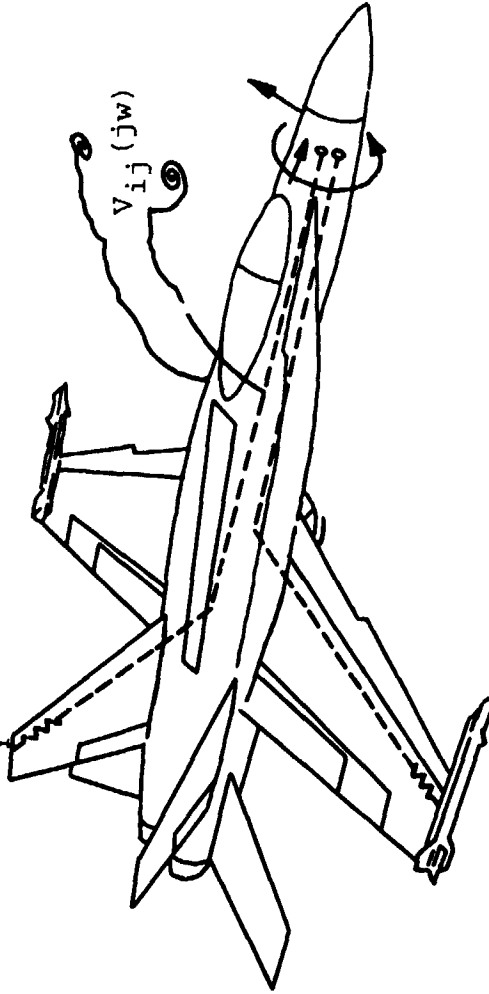

Figure 2

airframe material shielding function. Aircraft material shielding functions calculated for infinite planes can be modified as much as 16db by $T_2(j\omega)$, the geometrical airframe shape function. Lightning energy also reached the internal cables via metal-to-metal or metal-to-composite joints. Lightning's very long wavelengths are not significantly coupled through the joints as are the very short wavelengths in the microwave region. $T_3(j\omega)$ is representative of the frequency dependent joint transfer function. $T_4(j\omega)$ is the frequency dependent cable transfer function, while $T_5(j\omega)$ in figure 2 represents the avionic subsystem input function which can be viewed as input impedance. These five functions can provide the voltage that is produced across the avionic subsystem by an external environment such as lightning.

Figure 3 depicts the spectral content of lightning, derived by Cionos and Pierce, which is a compilation of numbers of ground-based measurements of lightning. What is particularly important to note in this figure is that lightning peaks at 50 kh, an extremely low frequency and in all probability the lowest frequency high energy driving function an airplane will ever have to survive. The constant line in Figure 3 represents the electromagnetic pulse driving function known as NEMP for nuclear electromagnetic pulse, which may be noted to run at a high level to approximately 100 MHz while the total energy content of this driving function is higher than lightning a more potential threat to composite aircraft.

To calculate the effects of lightning upon an aircraft with all composite material, composite and aluminum material and all aluminum material the driving function depicted in Figure 4 was analytically attached to the airplane as shown in Figure 4. In addition, analytical calculations were performed for these driving functions 100 meters away from the aircraft. These lightning-created voltage and current calculations assumed an internal unshielded aircraft wire 11.87 meters in length. Figure 4 poses the frequency characteristics depicted in Figure 3.

Figure 5 displays the magnetic shielding, $S_H = H_{\text{external}}/H_{\text{internal}}$ of T-300 graphite epoxy. Using a number of data sets, a broad stroke of +5db strokes was used to connect all the data points. From this evolved the magnetic field shielding characteristics of Figure 5. It should be noted that below 200 kilohertz, graphite epoxy is totally transparent to magnetic fields. As we go up in the spectrum the magnetic field shielding properties of graphite epoxy become markedly improved. By 100 megahertz they are in the region adequate for aircraft operation for present day threat environments. By microwaves, graphite epoxy is an outstanding reflector and indeed has been used in spaceborne antennas as the reflecting material. However, it should also be noticed that at one megahertz only 8db of magnetic shielding is exhibited by graphite epoxy. Since broadcast stations of 50,000 watts operate in this region a potential problem might be posed. Further work has to be done to determine the E and H fields radiated from the broadcast frequency antennas. Indeed, if the primary energy is in the E field then we will not have a problem. This is so because graphite epoxy exhibits excellent low frequency electrical E field shielding.

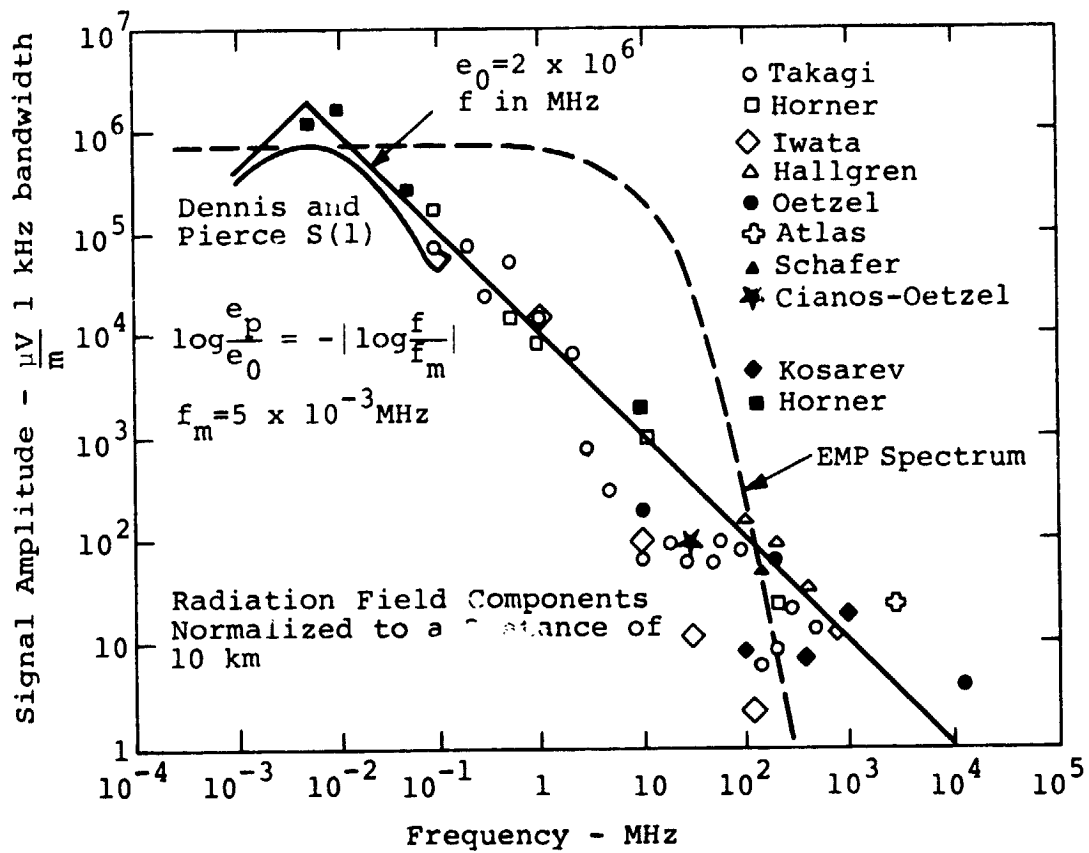

Peak Received Amplitude for Signals Radiated by Lightning Compared to an EMP Spectrum at 10 km (Lightning Spectrum after Cianos & Pierce)

Figure 3

Magnetic Shielding vs. Frequency for Seven Layer Graphite/Epoxy Overlay and Aluminum

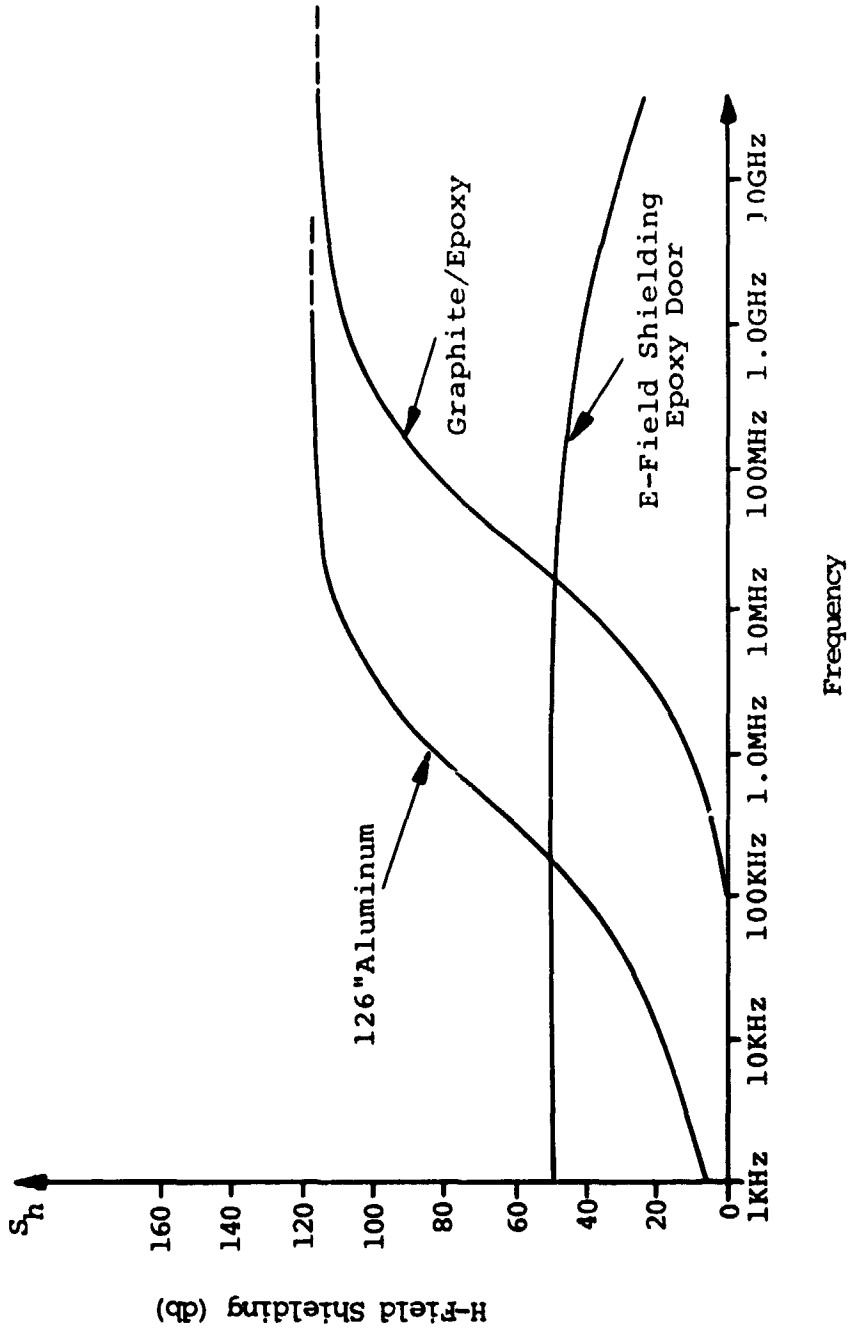

Figure 5

Unfortunately, this is all too often confused with magnetic field shielding. The curve also depicts the behavior of aluminum (Al) as a magnetic shield. As can be seen Al has substantial magnetic shielding even at the low lightning frequencies and definitely no problem at one megahertz. An example of electric field shielding is given in Figure 5 by the curve commencing horizontally at the left near 50db. This curve is the measured electric field shielding of a graphite epoxy door in an Al airframe. Normally, graphite epoxy exhibits approximately 80db of electrical shielding for the type of material measured. It should be noted in this curve that even at the base band, the electromagnetic leakage joints of the door, namely, the graphite epoxy to Al interface, lowered the electrical shielding 30db. By the time we are in the low microwave region joint leakage becomes significant through these joints and by 10 gigahertz substantially degrades airframe shielding properties. Indeed, graphite epoxy may be viewed as a very poor magnetic shield in low frequencies and a material whose electrical shielding is significantly degraded by its joint.

Taking these graphite epoxy shielding characteristics into consideration, voltages induced by lightning in a nearby stroke and by a direct stroke were calculated. The positioning of the wires used for these calculations may be noted in Figure 2. The open circuit voltage v_{oc} and the short circuit current I_{sc} on a wing are depicted in Figure 6 for nose-tail lightning attachment, the nearby lightning strike for nuclear EMP E field parallel to the fuselage, and for a nuclear EMP driving function with one E field perpendicular to the fuselage. Examining the upper table Figure 6 we see an all metal, closed cockpit airplane would allow only 10 volts to be induced while an all composite airplane allows 32,000 volts to be induced in a nose to tail lightning strike attachment.

The comparison between coupling through an Al to graphite epoxy joint versus the coupling through graphite epoxy is also depicted in Figure 5. We see on a composite tail a direct lightning strike will produce 23,000 volts due to diffusion while 2100 volts due to joints. Indeed, of the total 25,100 volts, lightning diffusing through the graphite epoxy may be viewed as the key contributor in this case. In the case of composite material access doors, we see the voltage to be 5,500 volts due to direct diffusion through the graphite epoxy and 1,400 volts due to the joint leakage. If the spectral content of lightning were of much higher frequency, namely, in the microwave region, we would see the joint contribution to be far higher than that of the diffusion. Again what is key to note is that at different frequencies different phenomena dominate and one cannot say in one simple statement with one simple parameter how graphite epoxy forming an airframe behaves. If the advanced composite material is not graphite epoxy, other composite materials generally provide much poorer shielding. The geometrical configuration influence $T_2(j\omega)$ discussed earlier has been included in these calculations.

Peak Transients on Nose/Tail Wire

Note: Values are given for open circuit voltage (V_{oc}) and short-circuit current (I_{sc}) from wire to structural ground.

Threat		Transient source	Configuration						
			All metal (closed cockpit)	All metal (open cockpit)	All composite	Composite tail		Composite access doors	
						Diffusion	Joint	Diffusion	Joint
LEMP	Nose/tail attachment	V_{oc} , V	10.1	-4500	-32000	-23000	2100	-5500	1400
		I_{sc} , A	0.3	-67	-1100	-750	70	-180	48
	Nearby strike	V_{oc} , V	*	-90	250	-54	21	-130	28
		I_{sc} , A	*	-1.3	8.2	-1.8	0.70	-4.5	0.95
NEMP	EII fuselage	V_{oc} , V	*	2200	102	15	-37	68	-19
		I_{sc} , A	*	28	1.5	0.15	-0.37	0.83	-0.22
	E I fuselage	V_{oc} , V	*	-	36	-	-	-	-
		I_{sc} , A	*	-	0.47	-	-	-	-

*Less than 0.1 volt (or amp)

Peak Transients on Nose/Wind Tip Wire

Note: Values are given for open circuit voltage (V_{oc}) or short-circuit current (I_{sc}) from wire to structural ground.

Threat		Transient source	Configuration			
			All metal (closed cockpit)	All composite	Composite wing	
					Diffusion	Joint
LEMP	Nose/tail attachment	V_{oc} , V	-2.1	-6500	-	-
		I_{sc} , A	-0.1	-220	-	-
	Nose/wing tip attachment	V_{oc} , V	-5.4	-17000	-11300	2800
		I_{sc} , A	-0.2	-550	-370	95
NEMP	EII fuselage	V_{oc} , V	*	84	-	-
		I_{sc} , A	*	1.3	-	-
	E I fuselage	V_{oc} , V	*	76	88	-24
		I_{sc} , A	*	1.1	1.0	-0.33

*Less than 0.1 volt (or amp)

Figure 6

Figure 6 also notes that nearby lightning located 100 meters away from the aircraft produces at most 250 volts for a total graphite epoxy platform while .09 volts in an all aluminum closed cockpit platform. The large current I_{sc} that travels along the wire which indicates high impedance circuits which were not used for these calculations might have greater voltages than those noted in Figure 6. Nonetheless, the levels of voltage for nearby strikes can be controlled if very low frequency (50 KHz) cable shielding $T_c(j\omega)$ is adequate. Adequate would be in the order of 60db. Currently, there are a variety of feelings if this can be met for an airplane that has flown for one year. The confusion is that in laboratories very high cable shielding can be accomplished while after a year of operation the vibration and corrosion may reduce the very high shielding numbers that can be obtained in a laboratory. This open item requires further clarification. The 0-100 MHz nuclear driving function we saw earlier was used to calculate the NEMP voltages and currents of Figure 6. The voltages generated in Figure 6 can generally be compensated for with presently available 40-60db cable shielding. Again, a key point here is that the spectral content of NEMP is much higher in frequency than that of lightning. The higher frequency NEMP spectral content appears to be adequately shielded by graphite epoxy and currently available 40-60db cable shielding.

Cable shielding values at 50 megahertz are fairly reliable and cable shieldings have been shown to peak between 30-50 megahertz in certain configurations. But cable shielding in the 50 KHz region can diminish 10-100 fold for many cable configurations. Again, the behavior of one transfer function at a particular frequency cannot be generalized to be the same at all frequencies. Unfortunately this assumption is often made in the hectic organizational environment. We must treat our functions as frequency dependent and not independent. This is a primary contributing factor which is making lightning difficult to deal with. Primary lightning penetration exists in the kilohertz region where cable shielding is often much lower than that in the 50-megahertz region.

Figure 7 depicts a double staircase and a riveted structural joint, respectively, from top to bottom. The double staircase joint has an admittance Y_j of 230 mohs per meter. This joint admittance is high enough to prevent significant voltage being created across it by the high lightning currents. The rivet joint is typical of the types being used frequently on current composite aircraft. The rivet joint has a joint admittance of 15 mohs per meter which is on the order of becoming unacceptable. Figure 8 shows voltages that result on the wire from (1) the penetration through composite material and (2) the penetration for different joint admittances direct attached lightning causes the joint type just discussed to have a voltage of 2,100 volts across it. The same direct attached lightning case produced only 41 volts across a good admittance of 230 mohs per meter double staircase joint. This voltage level is easily tolerable. Unfortunately, the building of the double step lap joint with high conductivity is extremely expensive and difficult to manufacture. Consequently, the structural community cannot afford to allow it to be built. Herein lies the problem of where we must trade off between what we can afford to build structurally and what we need electromagnetically. With some care the riveted joint

Structural Joints

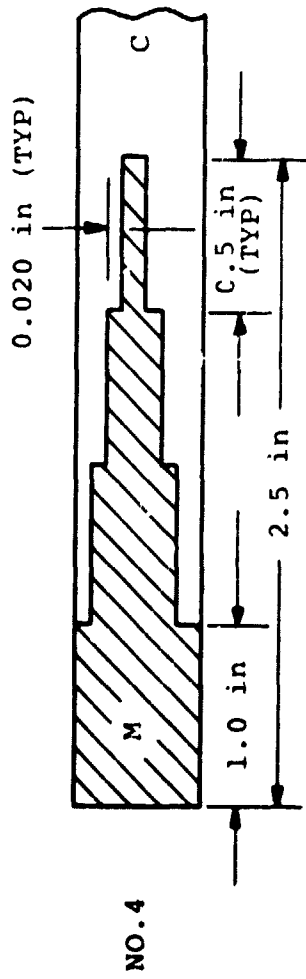

Y_J - Joint Admittance/Meter = 230 MHOS/Meter

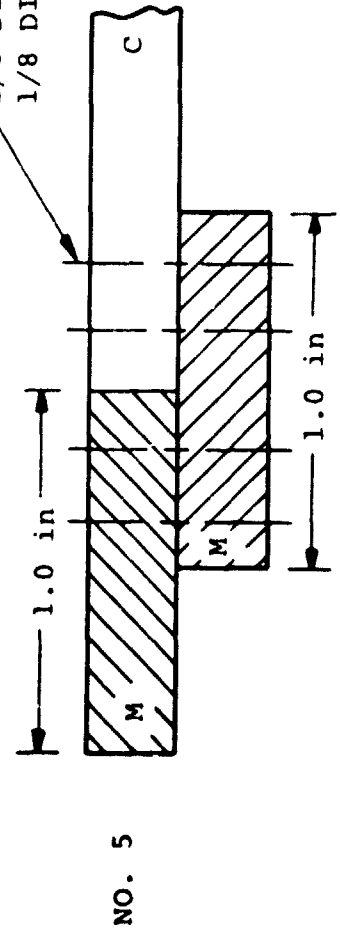

1/8 DIA RD HD RIVET C TO M
1/8 DIA BOLT M TO M



Y_J = 15 MHOS/Meter

Figure 7

Peak Open Circuit Voltages for Composite Structures vs Joints

Joint Structure Y_J (MHOS meter)	TAIL JOINT						WING JOINT				ACCESS DOORS				
	Comp.						Comp.				Co.p.				
		6	9	15	60	90		230	5	15		50	4	9	15
LIGHTNING	22K	3.5K	2.1K		350		11K	8.5K	2.8K	850	5.5K	2.4K	1.4K	240	
NEMP	15	90	37	9		2.4	60	72	25	7.2	68	19	7		

$Y_J = 15$ mho/m for Joint NO. 5 and
 $Y_J = 230$ mho/m for Joint NO. 4

Figure 8

can probably be made to have adequate admittance to prevent high voltages from being generated across them with a lightning strike. Analysis done for the NEMP driving function shows the voltages across joints to be much lower and tolerable. Figure 8 compares LEMP and NEMP generated joint voltage.

Graphite epoxy to Al joints which will not provide these high voltage generating capabilities are shown in Figure 9, Figure 10, and Figure 11. Cost must be determined for them to see if they are economically feasible. However, joint designs of these types have high admittance and would alleviate the problem discussed above. It should also be noted that a skirt joint, a joint with a line from the top drawn at 45° to the bottom with graphite epoxy on one side and metal on the other, has even lower joint admittance than the two pictured in Figure 7. The skirt joint has been measured to be 2 mohs per meter, and is seven times worse than the high kilovolt numbers we showed for the riveted joint. The riveted joint, double step lap joint, and skirt joint are drawn above their appropriate joint admittances in Figure 8.

Figure 12 uses the frequency distribution of the tasks which comprise VSTOL systematic electromagnetic design effort currently under way. On top we see threats broken into natural, friend and foe. The natural threats are composed of lightning which starts as we discussed earlier at the very low frequencies, precipitation static which slightly higher and may go as high as the microwave region, through its predominant range is usually 1 to 50 megahertz. Listed beneath the natural threats are friend and foe threats which exist throughout the spectrum. The dotted lines infer that they are becoming higher and higher in frequency.

To be able to analyze what each of these threats, or external driving functions, we referred to them earlier, does to a composite material aircraft, tests are performed on small finite size samples to determine the transfer functions which are noted as panels on Figure 12. The NAVAIR VSTOL systematic EM Design program will measure these transfer functions from very low frequencies through the microwave region plus certain discrete laser frequencies. The same panels will be replaced with graphite/epoxy aluminum joint panels similar to the ones previously discussed. These are representative of joints on the F-18 and the AV-8B composite aircraft currently being constructed. Test flights for the aircraft will commence late in the autumn of 1978. Knowing the transfer functions of composite material and composite material joining aluminum will provide the required data to calculate the internal EM field of a total structure. Such calculations are being performed for the AV-8B wing and forward fuselage. The AV-8B wing is almost a totally composite wing with just a leading Al edge and a few, approximately 1' x 1', Al apertures required for changing certain internal wires. Similar internal field calculations will be performed for the AV-8B forward fuselage which is entirely composite material. These calculations will use the transfer functions derived from small composite test samples to corroborate the validity of using small test samples for internal EM fields in full size aircraft. The total structure tests will radiate each of these full aircraft size from 1/4 khz through 18 khz.

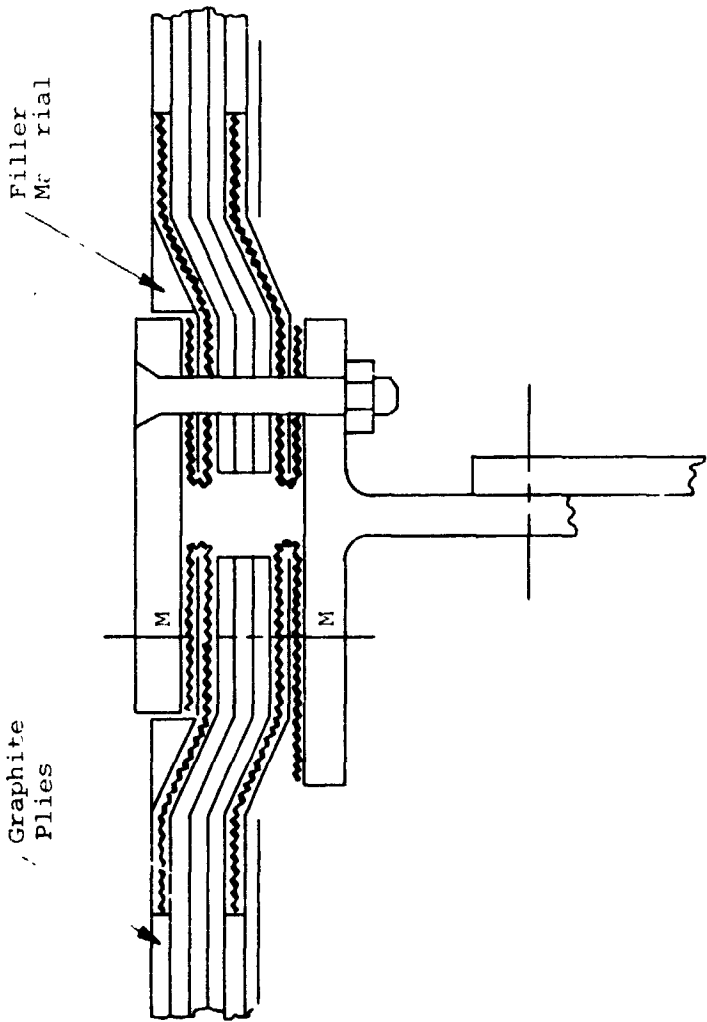

Typical Application - Skin Splice at Longeron or Spar Cap
 Load Transfer Mechanism - Titanium or Aluminum Splice Plates
 Potential Advantage - Easier Fabrication Due to the External
 Screen Plies

Figure 9

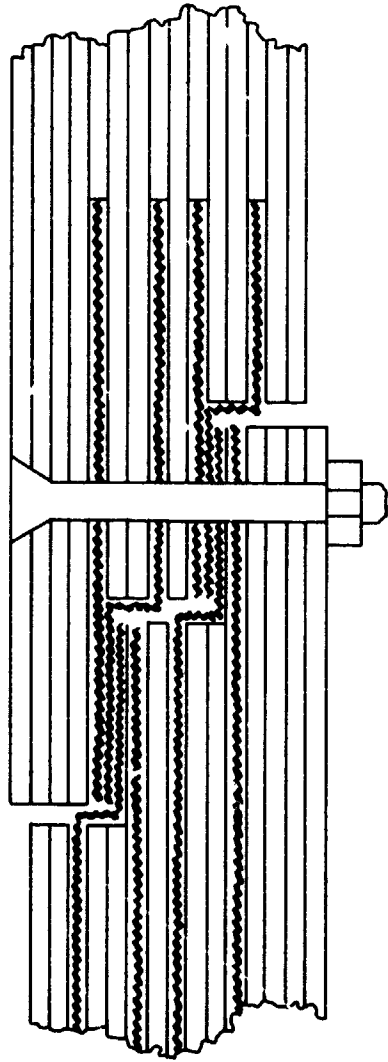

Multiple Exposed Screen, Mechanically Fastened
Stepped Lap Joint

Multiple Exposed Screen, Mechanically Fastened Stepped Lap Joint

Typical Stepped Lap Joint

Load Transfer Mechanism - Mechanical Fasteners

Possible Advantage - Positive Pressure in Screen
Interface Area

Figure 10

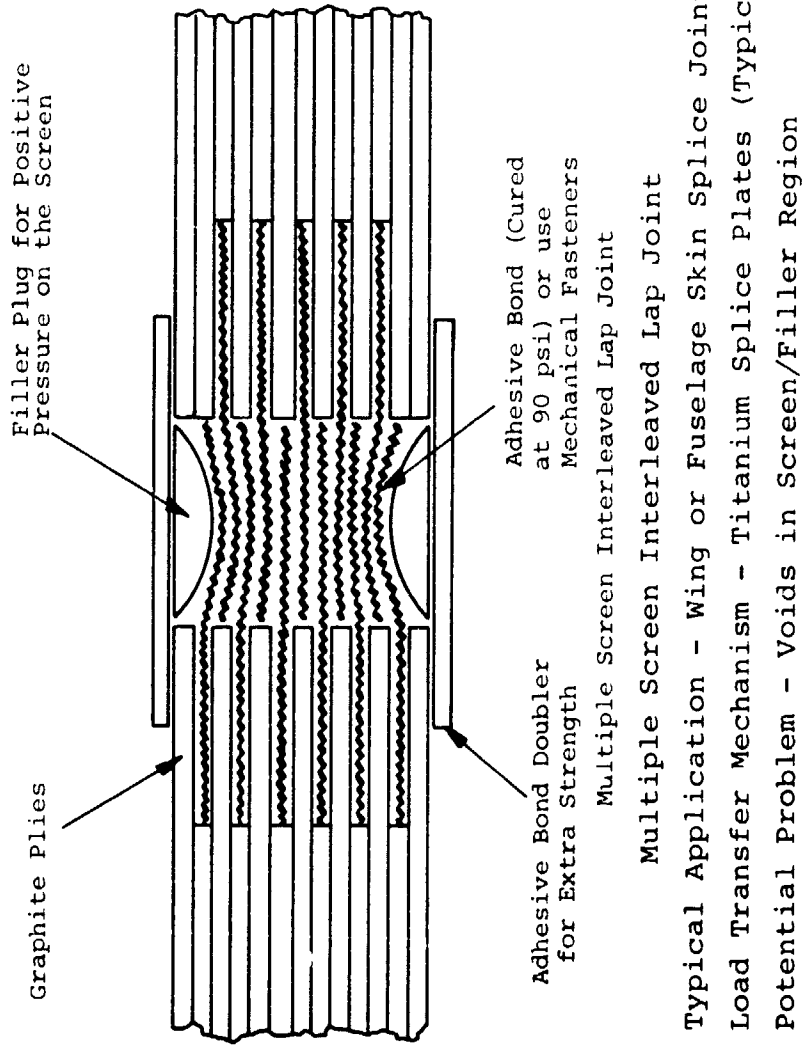

Figure 11

VSTOL Systematic EM Design
Task Frequency Distribution

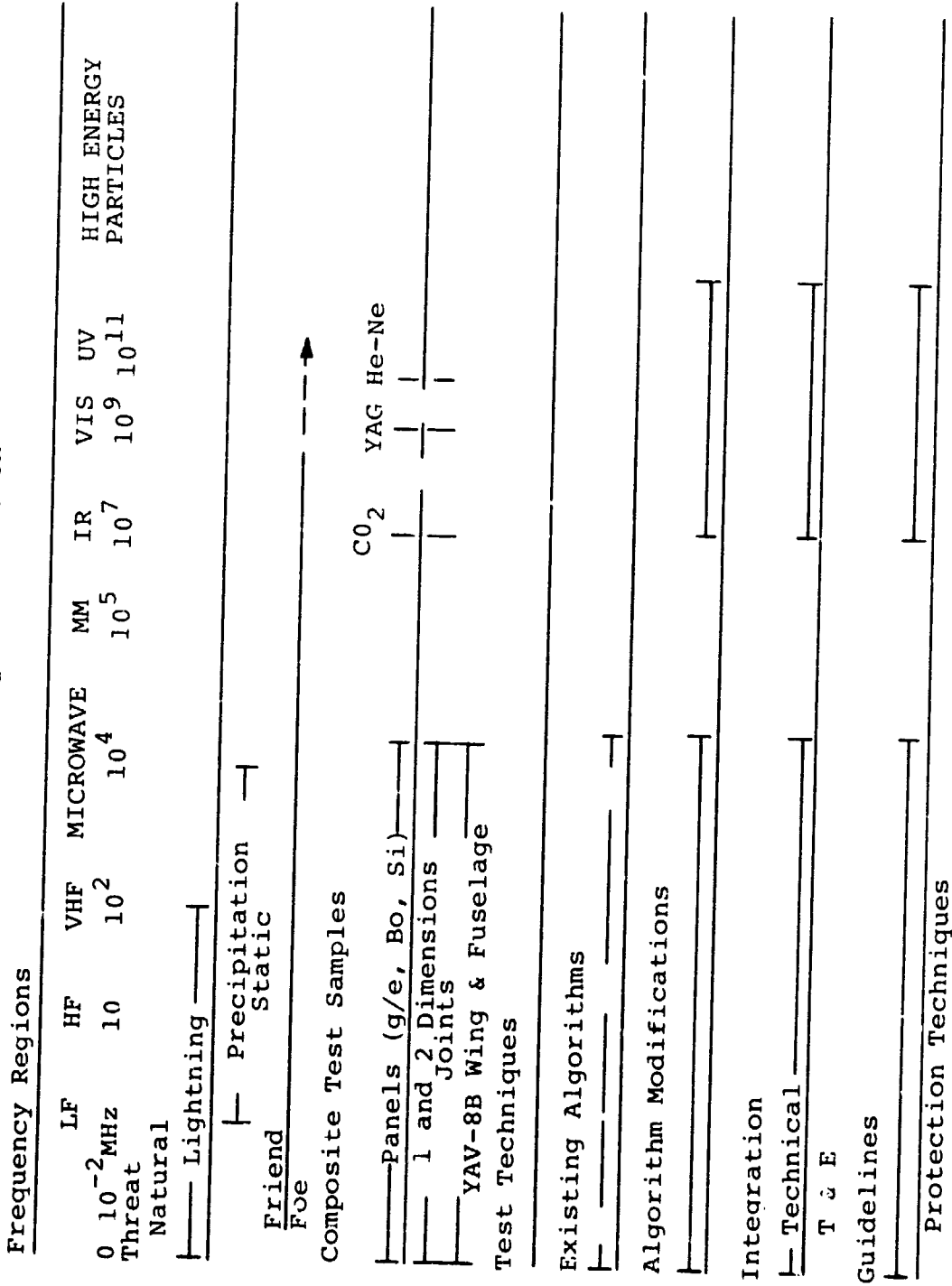

Figure 12

The test technique line in Figure 12 is not being actively addressed; however, various test techniques are evolving in order that we come up with our capability to do small size test sample transfer functions. Indeed, it is quite important that we record and further evolve the test techniques because testing composite materials is totally different from testing Al aircraft sections. This has been determined by a number of different contractors who have been awarded composite material study contracts. All of them have experienced difficulty adjusting to electromagnetic composite material testing because of the different electromagnetic intrinsic parameters, namely, different permeability, different permittivity, and different conductivity, all of which vary to some degree with frequency and are entirely different from Al intrinsic parameters.

The algorithm and modified algorithm line in Figure 12 indicate knowledge gained with the samples and full size composite section measurements will be compared to predictions namely the IAP program. This has been modified a zeroth order to account for differences between Al and composite. This will be used to predict the results expected in the AV-8B wing and fuselage experiments to verify if the transfer functions derived from the small sizes indeed allow us to predict the large size. If not, we will possibly use constants as the empirical data provides. The comparison will reveal how much detail beyond the zeroth order is required.

The above discussed tasks as indicated in Figure 12 require integration. This then leads to the publication of guidelines concerning the EM behavior of composite material guidelines which will inform industry of the information learned and provide them with presently unavailable constants.

Composite material electromagnetic problems can be solved with protection techniques such as fast time reacting diodes, Al flame spray, or intercolation, a process which increases composite material conductivity beyond that of copper (a process yet to be shown to be mechanically feasible). An additional protection technique is to take the problem that is predicted or empirically determined and use this as feedback information to redesign the composite material in a manner that will not provide the problem. This in itself is a protection technique which indeed may be the best solution. Unfortunately, scheduling often forces the use of problem compromising techniques as opposed to correct designs.

Figure 13 shows how existing metallic algorithms can be categorized in a general manner at the top of the figure, namely, a driving function going into computer analysis where platform data is available, thereby allowing the computer analysis to calculate interference to signal ratios. Currently, the specification generation, the system OK/not OK and the degree of acceptability function can be calculated. The bottom diagram in Figure 13 shows modification that will be made to allow application of these algorithms to composite materials.

Figure 14 lists the overall programs that exist in the Intersystem Analysis Program (IAP) series and shows various programs that NAVAIR has added to this collection. IAP data bases presently exist in varying

II. APPROACH

1. To minimize financial expenditures successfully demonstrated metallic EMC programs will be modified for applicability to composite materials.

2. A systematic approach will be employed. Today the Naval EMX programs, the Air Force Intra Systems (IAP) program, and the NASA MAPPS programs exist. Each of these efforts may be fit into the framework of Figure 1.

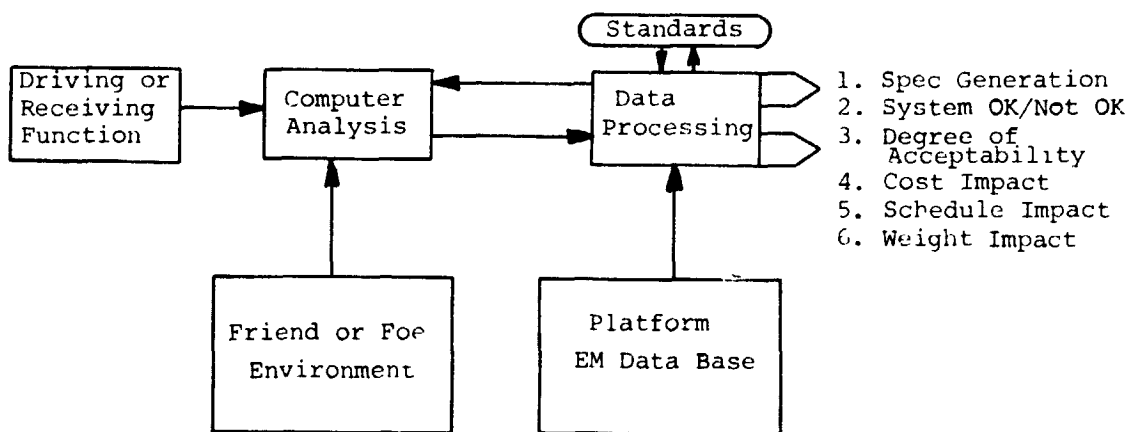

Figure a

Composite materials require the following modifications:

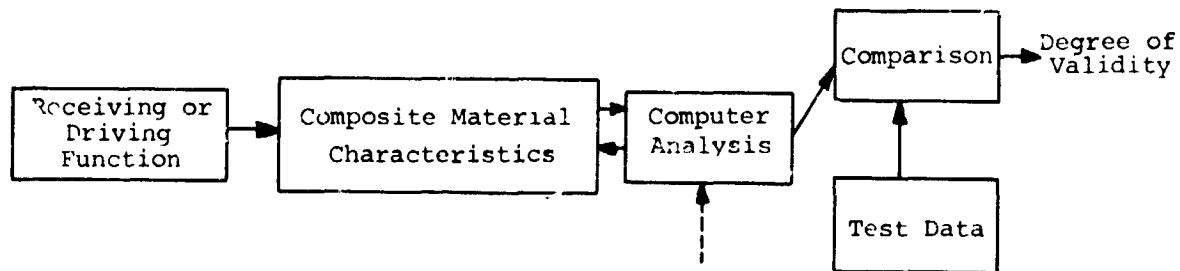

Figure b

Where the composite material characteristics may be subdivided into:

- * Infinite Plans Characteristics
- * Finite Plans Characteristics
- * Shaped Material Characteristics
- * Composite-Metal Joint Configuration
- * Diffusion and Penetration through Composite Skins

Figure 13

INTRASYSTEM ANALYSIS PROGRAM (IAP)

<u>ANALYSIS MODEL</u>	<u>ORGANIZATION</u>	<u>AF PROJECT OFFICE</u>
• Intrasystem EMC Analysis Program (IEMCAP)	McDonnell Aircraft Co.	RADC
• Supplemental Analysis Models		
• Electroexplosive Devices	Los Alamos SC Lab	ASD
• Electroexplosive Subsystems	Sandria Corporation	ASD
• Lightning	General Electric Co.	FDL, NASA
• Static Electricity	Stanford Research Inst.	ASD, SAMSO
• Tempest	TRW Systems GP	ESD, SAMSO
• Aircraft Stores	(In-House Project)	RADC
• Magnetospheric Substorms	(In-House Project)	AFGL, SAMSO
• Nonlinear Circuit Analysis	Signatron Inc.	RADC
• EM Fields Analysis	RADC, Syracuse U. BDM	RADC
• Advanced Composite Materials	Notre Dame University	RADC
	Rochester Institute of Tech.	
	University of South Florida	
• EMP	Boeing	NAVAIR
	NSWC/WHT Oak	NAVAIR
• Laser Interaction Physical Electronic Propagation	NSWC	NAVAIR
	NFDC	NAVAIR
• Power Systems	NASA/NOSC	NAVAIR
		NAUBLEX

FIGURE 14

totalities for the F-14, F-15, F-18, AV-8B, and B-52 aircraft. Figure 15 shows a program developed by the ENAMA group at Wright Patterson Air Force Base which allows the computer to draw the airplane and locate the antennas from an IAP data base. This allows easy pictorial envisioning of the airplane being analyzed. The very large collection of results that is generated by the IAP interference to signal calculations is able to be succinctly stated using a program developed at NAVAIR.

Figure 16 shows the antenna name, its location in inches along the butt line, water line, and fuselage station of the airplane shown in Figure 15, total EMI or interference to signal ratio. When positive, the interference to signal ratio (I/S) indicates a problem, namely the interferences is greater than the signal. When (I/S) is negative the interference is less than the signal. Therefore, by merely looking down the right-hand column of Figure 16 one can see what antennas are or are not being overwhelmed by interference. This is the system ok/not ok discussed earlier. Furthermore, the degree of acceptability is noted by the amount of db, let us pick one case which says -50.5db, that case is safe by 50.5db. If any efforts were made to achieve this, the extra shielding could be removed and recalculated on the computer. If a favorable I/S remained after shielding removal, money and weight could be saved for a problem that really did not exist. On the other hand, when we see a situation as depicted on the bottom line, the signal lies 59db beneath the noise environment. This type of problem requires immediate attention-indeed the amplitude shows it to be the priority of the fixes.

In summary, we have algorithms for the various areas depicted at the top of Figure 17. If the organized approach shown at the bottom of Figure 17 is utilized the disciplines can be woven together formulating an ordered electromagnetic semblance.

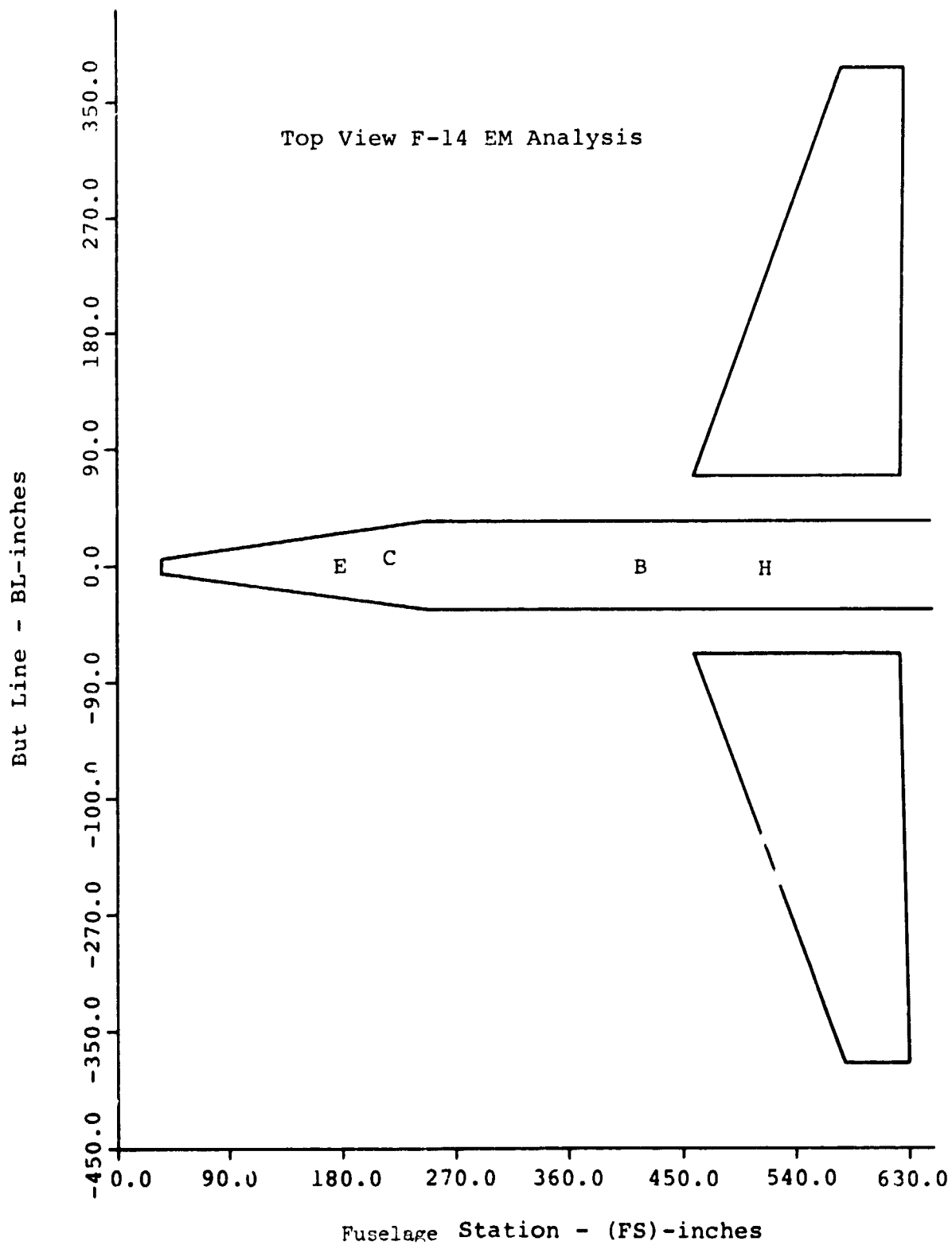

Figure 15

AIRCRAFT DATA

CON NOSL LIMIT FS (FSN) 250.0
 FUSELAGE RADIUS 34.0
 CORE RADIUS (RABC) 5.0
 CENTROID WL (WLC) 145.0
 BOTTOM WL (WLB) 120.0

WING POINTS

	BL	WL	FS FWD	FS AFT
Fuselage	63.5	161.0	460.0	625.0
Tip	334.7	165.0	530.0	630.0

AIRCRAFT ANTENNA DATA

Antenna Name	BL	WL	FS	Front	Side	Top	Total EMI = ±/S
TACAN	-05.0	95.0	663.0	A	S	A	+3 db
TACUP	3.0	192.3	411.0	G	B	B	-26.3
RDALT	9.0	123.5	207.0	C	C	C	**
ALTR2	-9.0	123.5	207.0	C	C	C	-50.5
ILG	3.8	106.5	171.0	C	E	E	-75.7
UHAOT	0.0	166.5	191.0	F	F	C	+45.0
ACLS	0.0	106.5	178.0	C	E	E	-72.5
IFF3P	5.5	177.5	811.0	G	H	H	-6.7
IFF2L	35.0	95.0	663.0	I	A	I	+0.6
UHAUX	3.0	192.3	411.0	G	G	B	+23.5
UAUX2	-86.0	95.0	663.0	A	A	A	+25.0
UHCOM	3.0	192.3	411.0	G	B	B	+25.1
UCOML	-85.0	95.0	663.0	A	S	A	+44.5
UDATA	-5.5	177.5	511.0	B	H	H	+46.5
UDTA2	35.0	95.0	663.0	C	A	I	+53.0

** EMI margin too high or input lacking.

FIGURE 16

In Summary

Today Algorithms Exist for

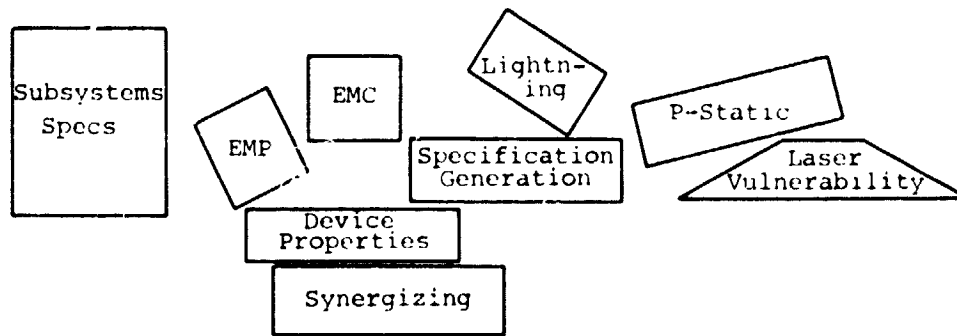

By Tying These Together We Have an Ordered EM Baseline

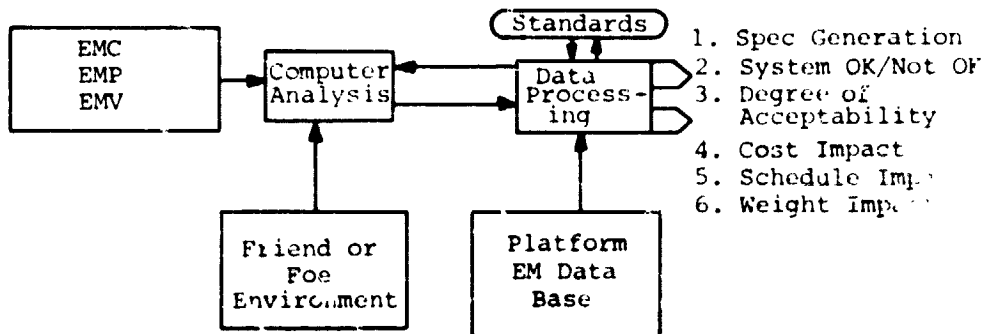

Figure 17



**SECTION VI
COMMITTEE
REPORTS**



**ORIGINAL PAGE IS
OF POOR QUALITY**

SUMMARY REPORT OF THE
SEVERE STORMS COMMITTEE

N79-17428

Jean T. Lee

National Severe Storms Laboratory/NOAA

Members of the Severe Storms Committee were:

Jean T. Lee, Chairman, NSSL/NOAA

Fernando Caracena, NOAA/ERL/APCL

Norman L. Crabill, NASA/Langley Research Center

John McCarthy, University of Oklahoma

William W. Melvin, Air Lines Pilots Association

Rance W. Skidmore, Air Weather Service, USAF

In addressing the severe storm aviation hazards, the Committee philosophy was for the Committee to direct its attention to the smaller scale severe storms (i.e., thunderstorms) with the expectation that the larger scale- (i.e., hurricanes) associated weather-hazard-to-aircraft problems would be simultaneously answered. Our discussions with the designated "floating" committees followed this lead.

At the end of this report is an appendix in which we list the top concerns voiced during each of these meetings. The Severe Storms Committee discussed these items in detail and the following summary and recommendations were developed.

1. Improve detection capability for hail, turbulence, wind shear, and lightning. This need has equal priority with item 2, below. Both should be addressed simultaneously.
 - a. For wind shear, it is recommended that the wind anemometer array system be looked on as an interim system. Continued development of ground-based Doppler radar and Doppler lidar should be accelerated to provide wind data along the glide slope. In the airborne realm, further development of methods to indicate wind differences between that at flight altitude and at touchdown should

be pursued, including airborne Doppler. Consideration should be given to the fact that dust fronts and low level wind shears occur at relatively undeveloped airports, in addition to the main metropolitan airports, and that these situations are of concern to both private and commercial pilots.

- b. For detection of turbulence in clear air, infrared radiometer devices appear to hold promise and research in this area should be supported; for turbulence detection in clouds, the Doppler radar is showing interesting potential.
 - c. Radar location of hail, as differentiated from heavy rain, may be possible through the use of dual wavelength radars, but the Committee questioned the requirement to differentiate hail from heavy rain. One might argue that the aircraft should not penetrate a heavy rain area in any case. Current experience suggests the need for better calibration of airborne radars.
 - d. Lightning is becoming more and more a potential hazard to safe aircraft operation. Several devices have been developed to provide airborne lightning detection. These need further research to define their capabilities; further development may be indicated. Currently, they should not be construed as turbulence or hail avoidance systems--only as lightning frequency indicators.
 - e. Icing -- Icing is more of a problem perhaps in stratified precipitation than in convective clouds. As aircraft design of both rotary wing and conventional aircraft aims toward all-weather operation with the least weight penalty, increased knowledge of drop size distribution and liquid water content in icing conditions needs to be acquired. Acceptable quantified definitions for light, moderate, and severe icing must be formulated.
2. Improve communications. Some items in Section 1, above, now have limited surveillance capabilities, but the inability of the system to rapidly assimilate and communicate the already available information to a pilot has been repeatedly demonstrated. The Committee suggests that thought be given to innovative ways for data presentation to the pilot. Examples include a UHF TV channel allocated to one-way weather briefing, in the ARTCC, or a data uplink from air route traffic control center to aircraft, perhaps.

In addition, development of simplified oral communications should be investigated to insure that the most important part of a message is not buried amongst less important information or during times when the pilot workload is high (e.g., weather updates during ILS approaches, etc.).

The proposed centralized SIGMETS is a step in the right direction. The consensus of opinion was that the pilot needs to make the decision while the controller and/or weather source should provide the advice necessary for a correct assessment of the hazard involved. This may also involve some expansion of the broadcast capability of FSS for reception down to the minimum en route altitude.

In the preflight situation, means to ease the flow of weather information to the pilot needs development--the aim should be to make it possible for a pilot to obtain all necessary information (pilot reports, weather briefers or sequences, forecasts, motions, file clearances, etc.) in one call. At some locations (e.g., outlying airports near large metropolitan airports) it is necessary to call more than one location to perform these functions; this sometimes results in omission of these calls and an inadequate briefing. While the Committee recognized that the pilot should be held responsible, it also recognized the fact that a complicated, unwieldy situation is unacceptable to the public and improved communication is mandatory--weather information is perishable.

3. Expand education and training. Information without knowledge of its use is of little value. It was pointed out in the wind shear situation that procedures for flying aircraft in such situations had been successfully developed some time ago. Until a series of incidents called attention to the problem, these procedures went relatively unnoticed, and still are in some areas. Aircraft design limits for wind shear should be publicized.

Similarly, as in the case of visual illusions that have been encountered during low visibility conditions, such as near a gust front, the airline industry has acquired a large amount of information and experience. However, the private pilots also need to be informed and trained. The Committee suggests that special "traveling" courses be established and presented to the aviation community at selected intervals to coincide with the advent of a hazard season. For example, a course on icing hazards or ice or slush on runways would be presented in early spring.

Until a simplified method of acquiring weather information is developed, a check list should be developed for acquiring various types of weather information or other flight information during various stages of flight (e.g., preflight, en route). Along with check list, a course should be planned on interpretation of severe weather information and reports.

These courses should not only be directed to the pilot, but should also be presented to air traffic controllers, National Weather Service forecasters, and Flight Service Station staffs before each season.

4. Improve forecasts by increasing accuracy in the short term. The Committee felt this was not an easy task to do in light of present organization structure. A forecast of severe turbulence whenever convective clouds occur is like a cry of "wolf" whenever a four-legged animal is seen. Similarly, a forecast of a gust front for all thunderstorms has little meaning--although all thunderstorms have gust fronts ("cold" air outflow on the surface). Only a few of these are of consequence to aviation and these are the ones that need to be pinpointed. Similarly, weather hazard forecast areas need to be reduced--probability statements should be developed to provide pilots with an overview of severe weather areas with high potential.

These problems require both industry and government attention. In some areas, such as training courses and educational programs, perhaps industry or educational institutions under government contract may be the most feasible approach method.

APPENDIX

Individual meeting discussions voiced the following concerns or areas requiring attention:

1. Meeting with Aircraft Operations Floating Committee
 - A. Need to increase lead time and decrease warning area for severe local storms.
 - B. Need to improve communications to pilots of severe local storm warnings.
 - C. Need to improve detection capability through development of instrumentation to detect all weather hazards to aircraft operations.
 - D. Need to develop techniques to be used by pilot and controller in assessing "weather information's critical potential."
 - E. Need to educate controller, pilots, and forecasters on severe weather factors affecting safe aircraft operations.

2. Aircraft Design Floating Committee
 - A. Need to define critical factors for aircraft design in severe local storm situations.
 - B. Need review of optimum flight procedures in flying in wind shear situations.
 - C. Need to assess trade-off between radar design and detection capabilities.
 - D. Need to determine influence of heavy rain on aircraft performance.
 - E. Need to determine effectiveness of current marketed instruments for lightning detection.

3. Weather Services Floating Committee
 - A. Investigate use of "auto-voice" (voice response) for weather information broadcast from VOR's and other facilities.

- B. Increase emphasis on education of flying public as to methods for obtaining and for interpreting severe weather information.
 - C. Develop better and/or additional instruments for gust front, low ceiling and other severe weather phenomena detection.
 - D. Need to prepare a "scenario" of events that should be followed in flight planning.
 - E. Increase training or retraining of pilots, controllers, and weather factors to be considered in flight operations.
4. Data Acquisition and Utilization Floating Committee
- A. Increase effort to obtain wind information on take-off and landing by inertial platform-equipped aircraft.
 - B. Increase coverage of flight service stations en route weather service systems so that the broadcasts can be obtained when flying as low as the minimum en route altitude.
 - C. Increase emphasis on data presentation simplification.
 - D. Increase development of automated sensors for thunderstorm location and occurrence at automatic observing stations.

**ORIGINAL PAGE IS
OF POOR QUALITY**

SUMMARY REPORT OF THE

TURBULENCE COMMITTEE

Charles E. Elderkin

Battelle Pacific Northwest Labs

N79-17424

Members of the Turbulence Committee were:

Charles E. Elderkin, Chairman

L.J. Ehernberger, NASA/Dryden Research Center

David J. Moorehouse, AFFDL/FGC

Harold N. Murrow, NASA/Langley Research Center

Edwin A. Weaver, NASA/Marshall Space Flight Center

Guy G. Williamson, ARAP

The effects of atmospheric turbulence must be considered in two primary areas of aviation. The first is aircraft design and the second is aircraft operations (flight control and response). Descriptions of turbulence in terms of intensity and scale are important to design considerations and are usually expressed through models. Turbulence models are often used in the form of discrete gusts, spectral distributions and probability distributions.

For input to operations, turbulence information is usually less quantitative and detailed. Estimates warning of what effect to expect and when to expect it must consider not only the character of the turbulence but the response of the aircraft as well. Pilot response must also be considered here.

Workshop interactive sessions were held where the Turbulence Committee met with other committees and considered various aspects of the design and operation problems. Separate sessions dealt directly with aircraft design and with aircraft operations. Another session with the Human Factors Committee related primarily to operations, considering pilot interpretation of turbulence events and discussing simulation and training factors. The session with the Weather Services Committee also related primarily to operational aspects, dealing with observations and forecasts of turbulence encountered at altitude and in terminal (landing/take-off) operations. The session with the Data

Acquisition Committee related to both design and operations, but concentrated mostly on the more detailed measurements of turbulence required to develop models and provide thorough descriptions of turbulence statistics in connection with design.

Turbulence and Aircraft Design

Turbulence plays an important role in aircraft design. Significant improvements have been introduced in accounting for gusts and turbulence over the years in design studies. Early, sharp edge gust models have been replaced by complex, discrete gust descriptions and continuous turbulence statistics, i.e., spectral and probability descriptions.

Design models of turbulence, used in evaluations of maximum loads, fatigue, and control, are based primarily on measurements. Although current models are presently serving the purpose, additional turbulence data collection programs are warranted. This should lead to more realistic and comprehensive models of turbulence, especially important for future generation aircraft.

Historically, measurements of turbulence taken during the U.S. Air Force Clear Air Turbulence program at several levels in the atmosphere provided a data source for design purposes. Also in the Jim-sphere program, balloon data have been taken at Vandenberg AFB, Cape Kennedy, White Sands, Wallops Island and Edwards AFB, which provided vertical soundings of winds and turbulence. Tower mounted turbulence sensors have also given three wind component turbulence data from multiple tower arrays at a number of locations, providing some spatial and temporal information on turbulence.

More recently, a continuing program of turbulence measurement from aircraft has been conducted by NASA. Their Vgh program uses measurements of the three variables, speed, vertical acceleration, and altitude, from several types of aircraft. The data analysis removes effects of aircraft responses on the data providing comparable wind component results for data sets from several different aircraft. Also, NASA's Measurement of Atmospheric Turbulence (MAT) program is collecting data for input to design models utilizing a system with two vanes and a sensitive air speed indicator which gives fast response measurements of the three wind components. Rate gyros with an inertial platform provide necessary aircraft motion information. The system is operated under all meteorological conditions and over a wide range of altitudes. Goals are much the same as in the earlier Air Force HiCAT program, but recent improvements in instrumentation and data collection and reduction methods permit more definitive and reliable results. Concurrently with the turbulence measurements, inflight data on wind and temperature is taken. Also, appropriate nearby routine NWS Rawinsonde soundings are obtained.

More data on turbulence extremes is needed for an improved understanding of the marginal conditions or worst cases an aircraft must be designed to withstand. Cost could possibly be reduced if upper limits of turbulence intensity could be specified more accurately. Aircraft designed for different missions might not need to consider the same limits of turbulence intensity, although it was pointed out that missions can change after a period of operations in a given mode and an overall turbulence design criteria might be best.

The requirements for defining the spanwise variation of turbulence velocities was expressed as a strong need. The design of future large cargo and flexible wing aircraft must account for the variations in gusts occurring over the spatial extent of the aircraft. Little information exists on this important aspect of turbulence. Currently, first order estimates of such effects are included in the form of rotational disturbances, in the disturbance model of the military flying qualities specification. Such effects could be included in commercial design or simulation programs as well. Current models are quite crude, and additional measurements and better modeling of spatial variation of turbulence is recommended.

Turbulence and Aircraft Operations

Turbulence can present serious inflight hazards to aircraft as well as increased work loads for pilots. Thus, turbulence as it relates to aircraft structure and performance and to pilot perception and fatigue is important to consider. These factors are involved in both operations enroute at altitude and in terminal operations.

Methods have been established for handling operations at altitude in Clear Air Turbulence (CAT). The basic approach is to avoid it wherever possible. The military forecasts mountain waves, severe CAT, etc. and where areas are suspected to be hazardous from CAT, they are closed to training missions and other routine operations. Commercial airlines also forecast turbulence and get pilot reports from operating aircraft. They then reroute flights around affected areas or change altitudes to avoid turbulence. General aviation pilots do not get such specialized forecasts of turbulence for their flights and aircraft types. This may present some serious potential problems.

The apparent reduction in CAT incidents/accidents was discussed and attributed to two factors. First, pilots are now trained to control attitude during an encounter and not try to maintain altitude, which eliminated upsets resulting from loss of control. Second, the reports of encounters by airline pilots are very effective in allowing other aircraft to avoid encounters. The reports will vary from aircraft to aircraft and pilot to pilot. (It was noted that the airplane's response is a function of Mach number, aircraft type, wing loading.) A need was expressed for a standard terminology in reporting encounters. A pilot senses fluctuations in normal acceleration--numbers used were

± 0.1 g light chop, ± 0.15 g for moderate chop, and ± 0.2 g strong chop. It was stated that pilots infrequently encounter severe turbulence which can be traumatic without prior experience. Control inputs by the pilot in response to turbulence may amplify the motion.

The above led to a discussion of simulation, and some acknowledged deficiencies of typical simulators were put forward. The effect of increasing turbulence is to increase the pilot work load in controlling the airplane, until in severe turbulence the pilot has trouble reading the instruments and performing the necessary functions of control and communication. Even with the deficiencies of simulators, if care is taken to ensure that nothing is grossly unrealistic, then such simulator training can only benefit a pilot.

Remote sensing instrumentation for detecting and avoiding CAT was also discussed. A basic question relating to how useful such systems would be was how low a fail rate must it have for a pilot to trust it and use it. It was noted that if a CAT detection device were used a pilot could tolerate some false warnings, but non-forecast encounters would have to be very light for the pilot to retain confidence. An occasional severe encounter following a warning of moderate CAT would be tolerated. A pulse doppler Lidar detector for CAT is presently undergoing development and feasibility testing (NASA/Marshall) for use from aircraft over a range from 600 meters to about 15 km (depending on aerosol concentrations) ahead of the aircraft. An infrared radiometer CAT detector (NOAA) has also been developed and is being evaluated.

For handling turbulence and wind shear problems in terminal operations, it is important that there are adequate real-time observations of turbulence in the terminal area, and that there is appropriate communication of those turbulence conditions to pilots. Effective training programs are also important, incorporating realistic simulation of turbulence encountered in take-off and landing operations. For flight planning it is also useful to have forecasts anticipating the likelihood and severity of turbulence conditions in the terminal area.

The measurement of even simple turbulence and wind shear parameters for advising pilots on conditions for take-off and landing is difficult at best. Presently used standard wind instrumentation at airports does not provide sufficient information. Experimental remote sensing has been attempted in this application with only limited success. The observation problem is compounded by the fact that turbulence occurs quite randomly in space and time. Severe gusts, in particular, are infrequent events and detection with conventional equipment offers very incomplete sampling. Estimating the turbulence statistics through relationships with more general and readily observed variables may or may not be possible for providing turbulence information in the terminal area. Present state-of-the-art in modeling boundary layer

conditions is not at a point which permits such estimations to be made with sufficient confidence. Estimates of wind shear and variability are also being made in a few cases from aircraft navigational systems (by one airline down to 100 feet from the ground) which would provide useful information for monitoring changing turbulence and shear conditions around airports. However, data and results are not immediately available from these systems. It is clear that observation or turbulence and shear information is not in a satisfactory state for dealing with aircraft take-off and landing problems.

Similarly, communicating useful and definitive information on turbulence and shear to the pilot is not being achieved as it should nor is it clear what form of information is best suited to his needs. While turbulence is defined and investigated in terms of root-mean-square values, spectra, and length scales, the pilot needs some simple indices or ratings of turbulence. Such indices and their relationships to more comprehensive descriptions have not been fully developed and clarified.

It is very difficult to arrive at specific, clearly understood indices because:

- Different aircraft have different responses to the same turbulence.
- Pilot perception of turbulence can vary.
- Pilots are exposed to turbulence only a fraction of the time (avoiding it most of the time); what they experience may not be what is described on a more general basis.
- General aviation pilots for the most part do not have an understanding of turbulence and wind shear.

Also, these factors warrant an active training program to familiarize pilots with what they can experience with different aircraft under various atmospheric conditions. The Air Force is currently assessing the question of whether to include wind shear in training simulators. It is suggested that airline pilots could equally well benefit from simulation training in the effects of turbulence, wind shear, etc. The use of simulation may be especially beneficial for terminal operations in slow, insidious cases of wind shear where the pilot gets behind the response and then either never "catches up" or else overcontrols into a crisis situation.

Forecasting turbulence is especially difficult. The National Weather Service (NWS) gives broad, general forecasts, unusually qualitative in nature. The more general forecasts of CAT conditions by NWS are often elaborated on by others and specialized forecasts derived

which are suited to individual needs. For near surface conditions, boundary layer models may help in the future to forecast for terminal operations. Limited resources and a broad range of customers precludes NWS from providing more specific forecast products for aviation. This leaves the final tailoring of turbulence forecasts to specific needs in the hands of the various users. For general aviation, a primary customer of the NWS, a serious problem in perceiving turbulence conditions results because of the limited understanding of turbulence by this segment of the aviation community.

Recommendations

1. Continued research is needed for understanding and describing turbulence and wind shear. Wind shear effects in terminal operations remains one of the most serious problems in aviation meteorology. Existing data on turbulence and wind shear from aircraft and towers should be exploited to the fullest.
2. Present capabilities and facilities should be used to fill gaps where more experiments are found to be needed, e.g., the NASA MAT program should continue with spanwise turbulence measurements and correlations included in the future and emphasis on probing at low altitudes, approaching worst case conditions. Severe turbulence at lowest altitudes could also be investigated further through tower based measurements. Improved models for design and simulation should result.
3. Use should be made of en route information from airlines on winds and turbulence and related to satellite and other meteorological information, leading to reporting, mapping, dissemination, and use in aircraft operations of this data. Similarly, with terminal area winds and turbulence data collected from airlines on landing, correlations to synoptic conditions and local variables available should be studied and related to operational needs.
4. Development of better instrumentation for detecting and monitoring wind, wind shear and turbulence should be emphasized. Attention should be given by government agencies to doppler radar, laser and acoustic radar developments and testing. Less sophisticated, inexpensive systems should also be considered.
5. There is a need for a methodology to quickly get turbulence information to pilots to make judgments. This must include the development of a simple (indices), consistently understandable (quantitative), description of turbulence which accounts for or can be used with aircraft response characteristics information. It should permit the pilot to judge the expected impact.
6. Aviation weather hazards occur on a meso- and microscale. Research in this area applied to aviation has been small and a consistent

effort is needed. Work is being done but not of sufficient depth to bring it to use by forecasters. Among other things, this should lead to meeting the urgent need for wind shear forecast capability.

7. Educational programs, incorporating turbulence descriptions and effects on aircraft response, similar to current programs for airline and military pilots, should be developed and made available to general aviation pilots.

8. Opportunities presented by meteorologists being placed in ARTC Centers should be pursued in connection with turbulence evaluations (both CAT and Low Level). The turbulence investigations should have relationships to surface and satellite based meteorological data thoroughly studied and established.

9. A need exists for increased dialog in aviation meteorology. It is necessary to have face-to-face interactions between groups of scientists, engineers, and operations personnel with different backgrounds. More conferences and workshops are needed to match specific needs with research goals and products.

2301-010

SUMMARY REPORT OF THE

ICING COMMITTEE

Richard I. Adams

U.S. Army Aviation Research and Development Command

Members of the Aircraft Icing Committee were:

Richard I. Adams, Chairman, Army

Cpt. Garry C. Jackson, USAF Flight Dynamics Laboratory

Robert L. Klapprott, FAA, Wichita, Kansas

James Luers, University of Dayton

Dennis W. Newton, Cessna Aircraft Company

Porter J. Perkins, NASA Lewis Research Center

The bases of reference for discussions among members of the Aircraft Icing Committee and the various Floating Committees were the Overview Paper presented by Porter J. Perkins, and a list of suggested questions. Initial discussions were aimed at developing a specific list of problem areas that exist today. Subsequent discussions refined the list of problem areas and developed recommended actions necessary for resolution of problems.

Problem areas identified are listed in general descriptive categories as follows:

- Instrumentation
- Facilities
- Forecasting
- Design Criteria
- Data

Other problem areas were identified during discussions with Floating Committees. Discussions of these other problem areas may be found in the various Floating Committee Reports. These other problem areas are listed for reference purposes as follows:

N79-17425

Pitot static system icing problems

Carburetor icing problems

Antenna icing effects upon radio static

Ground frost formations and methods of removal

Discussion

Mr. Porter Perkins, in his overview paper, basically concluded that NACA research efforts during the 1950 time frame had identified the range of icing parameters. Mr. Perkins concluded that problem areas that existed in the late 1950's, when NACA reduced their level of R&D effort, could possibly remain as problem areas today. NASA reduced their R&D effort because the range of icing parameters had been well documented and the advent of the high altitude, jet aircraft minimized the overall icing problem. The areas referred to by Mr. Perkins that may require further development were icing instrumentation and more accurate prediction of icing severity level. Mr. Perkins commented that "despite the lack of recent development efforts (by NASA), much of the past work will apply to today's needs."

In his overview paper, Mr. Perkins scoped some of the problems that exist today. The past NACA work does apply to most of today's needs and formed a basis for the meteorological design criteria contained in the Federal Air Regulations and Military Specifications today. These requirements have stood the test of time for many years for high altitude, high speed, fixed wing aircraft. With the advent of the helicopter and other low speed, low altitude aircraft such as the US Air Force A-10 and Cruise Missile requirements, and larger numbers of low altitude fixed wing aircraft, other problems have become apparent that require additional R&D efforts and reexamination of the meteorological design criteria. These problem areas and recommended resolutions are discussed in the following paragraphs.

Instrumentation

Instrumentation capable of measurement of various icing cloud parameters are necessary for icing research and certification flight tests and for operational usage. The primary parameters requiring accurate measurement include cloud liquid water content (LWC), droplet size (D_0), and outside air temperature (OAT). In addition, because of the unknown influence of cloud ice crystal content and the conditions produced by a combination of supercooled liquid water and ice crystals (the mixed icing condition), the need for instrumentation to measure ice crystal content has recently been identified as a research need.

Outside Air Temperature (OAT)

The accurate measurement of OAT is essential for research and certification icing flight testing purposes as well as for operational usage. The onset of aircraft icing can occur in a very narrow band of OAT requiring sensitive and accurate measurement of OAT. Technology is considered adequate today; however, the recognition of the need for a high degree of accuracy by military and civil operators may not be apparent. To assure that operators are aware of inaccuracies of currently used OAT instrumentation, additional training should be instituted by military and civil operators.

Liquid Water Content (LWC)

LWC is the primary parameter that affects the icing severity level and thus becomes very important for research, development, certification, and operational purposes. Several devices such as the rotating multi-cylinder and rotating disc have been used over the years for the purpose of measuring ice accretion rate which is relatable, by calibration, to LWC. These devices are considered accurate, however, cumbersome and difficult to handle during flight testing. These devices cannot satisfy the need for measurement of LWC for operational usage.

In the past few years, as a result of helicopter icing R&D programs, several electronic ice detectors have been developed for helicopter applications. These devices are capable of measuring the ice accretion rate and, by electronic means, provide voltage signals that can be used for direct determination of cloud LWC by test engineer or pilot station display in digital or analog form. These signals can be recorded, telemetered, or used by onboard observers as necessary. These devices (ice detectors) are accurate to within $\pm 10\%$ over the LWC range from 0 to approximately 1.5 gm/m^3 . For these devices, inaccuracies increase near the Ludlam limit which normally occur above ambient temperatures of -5°C . Improvements are needed to extend the usable range of ice detectors up through approximately 3.0 gm/m^3 and up to ambient temperatures of 0°C .

The U.S. Army is currently anticipating usage of existing ice detectors to provide cockpit display of icing severity level, in terms of LWC and OAT, for the BLACK HAWK (UH-60A), Advanced Attack Helicopter (YAH-64A), and the partially ice-protected UH-1H. Cockpit display of icing severity level is intended to overcome the inaccuracies that currently exist in icing forecasts to allow air crews to monitor the icing severity level limits of their aircraft, to provide a capability to quantify the effect of evasive maneuvers, and to quantify pilot reports.

Droplet Size (D_0)

Although D_0 is not considered necessary for operational use, this parameter is essential for research purposes. In most certification tests, the FAA requires measurement of droplet size. Two methods are currently used for droplet size measurement, i.e., gelatin slide and laser nephelometer. Both have disadvantages for flight test purposes. The gelatin slide technique is limited to the number and frequency of samples that can be taken and the data processing is cumbersome and time consuming. The laser nephelometer is a fairly large and heavy installation and becomes difficult to install on some small aircraft.

Improvements in droplet size instrumentation are needed to facilitate research and certification flight testing.

Ice Crystal Content (ICC)

Recent helicopter simulated and natural icing flight testing, conducted by the British and U.S. Army, has cast serious suspicion that the presence of ice crystal in combination with supercooled liquid water drastically influences the shape of ice formations and possibly the ice accretion rate on helicopter rotor blades and other components. This apparent phenomena cannot be immediately quantified because adequate instrumentation is not available to measure ice crystal content. In addition, it is expected that ice crystal type, size, and shape could be influential in the phenomena observed to date. Experiments are in progress in the UK to evaluate the Knollenberg camera and other devices for use in quantifying ice crystal effects. Experiments are also in progress in the Canadian National Research Council to determine the effects of ice crystal and liquid water ratios under various conditions. All work known to date is being performed using icing wind tunnels.

There is an immediate need to develop instrumentation capable of quantifying ice crystal content simultaneously with supercooled liquid droplet characteristics. Icing tunnel evaluations must also be extended to the natural environment and to an understanding of the mixed icing condition phenomena developed.

Facilities

Recent helicopter icing R&D efforts have once again led to the conclusion that reliance upon natural icing testing for certification purposes is very costly, time consuming, and uncertain. The upper limits of meteorological design criteria are rarely encountered requiring extrapolation of test data for certification purposes.

A large number of military and civilian helicopters and possibly light fixed-wing aircraft are expected to be designed for flight in icing conditions during the next few decades. Without adequate simulation facilities, certification of these aircraft for flight in icing conditions will be a difficult and costly task.

The recommended solutions to these problems are the improvement of existing simulation facilities and development of new simulation facilities, all for use in icing research, development, and certification purposes to reduce the reliance upon natural icing testing. These facilities include icing tunnels, ground based facilities such as the Ottawa Spray Rig, and airborne simulation facilities.

Several facilities currently exist, but each has limitations that must be overcome:

Existing icing tunnels do not cover the full range of parameters nor are they suitable for full scale testing. Some icing tunnels such as the NASA-Lewis tunnel may be suitable for component testing in the lower speed range.

The Ottawa Spray Rig, the only such facility in the free world, is used primarily for helicopter icing₃ research and development. This facility is limited to LWC of 1.0 gm/m³ and is usable only during winter months (December through mid-March) when ambient temperatures are low. In addition, the Ottawa Spray Rig is usable only within a narrow band of surface winds between approximately 7 to 30 mph. The Ottawa Spray Rig can only be used to simulate the effects icing has on certain aircraft components such as rotor blades in hover and propellers in the static thrust condition.

In-flight simulation facilities currently in use are the U.S. Army Helicopter Icing Spray System (HISS) and the U.S. Air Force KC-135. Cessna aircraft has a small tanker that has been used in certification programs for light fixed-wing aircraft. These in-flight simulation facilities are limited primarily in the realistic simulation of droplet size, but also have limitations of cloud size, airspeed range, liquid water content range, and endurance.

While it is recognized that improvements and developments are needed, the proper mix of facility types are not known at this time. It is, therefore, recommended that the first step in the solution of this problem is for NASA, FAA, and the military services to jointly participate in a facilities study effort to determine the proper mix of simulation facilities and to develop a program to attain the commonly agreed upon goal. Use of modeling techniques to supplement or reduce facilities requirements should be considered in this study. Facilities improvements, developments, and operation are considered a NASA responsibility.

Forecasting of Icing Conditions

Weather forecasting has been judged by operators of military fixed wing aircraft and helicopters, that are not equipped with ice protection equipment, to be accurate approximately 50% of the time. The U.S. Army helicopter fleet in Germany is grounded approximately 30% of the time during winter months because of forecast icing conditions. In addition, numerous inadvertent icing encounters have been reported when no icing forecast exists. The U.S. Army is currently working with the U.S. Air Force Air Weather Service to seek a resolution of this serious problem.

In relation to this problem, aircraft fall into three categories, i.e., those certified to FAR or MIL-SPEC requirements, those without ice protection, and those with partial ice protection. The consensus of the Aircraft Icing Committee is:

(1) Aircraft certified to FAR's do not experience problems with icing forecasts.

(2) Unprotected military aircraft, including both helicopters and fixed-wing aircraft, are needlessly grounded at times because of inaccurate icing forecasts. Inadvertent encounters of nonforecast icing conditions are reported at other times. It is expected that unprotected general aviation aircraft would have a similar problem, but this could not be confirmed during the Committee meetings. An FAA study is recommended to resolve this issue.

(3) The U.S. Army is planning the deployment of two helicopter types in the near future that will have partial icing flight capability. Complete ice protection equipment is installed, but the ice protection equipment will not allow flight in all icing conditions. LWC and OAT limits of approximately 1.0 gm/m^3 and -20°C , respectively, will be imposed. A third Army helicopter, the UH-1H, will be equipped with a partial ice protection system to protect all components except rotor blades. This is believed to be an interim measure until rotor blade ice protection can be implemented. This helicopter, with partial ice protection, is expected to be limited to icing severity levels defined by LWC and OAT of approximately 0.25 gm/m^3 and -5°C , respectively.

(4) More accurate forecasts are necessary to allow availability of unprotected military and civilian aircraft (helicopters and fixed wing) to be improved; forecasts need to be improved to the extent that the icing severity level can be stated. The icing severity level should be stated in quantified terms such as LWC and OAT rather than subjective terms such as trace, light, moderate, etc.

To facilitate solution of the unique problem of the Army, the three partially protected helicopters will be equipped with icing severity level indication systems. This equipment is considered essential to allow safe penetration of suspected icing conditions, especially in view of inaccurate icing forecasts. This equipment will include cockpit display of cloud LWC and OAT that can be used to qualify pilot reports. Efforts should be established by the U.S. Air Force Air Weather Service to determine if pilot reports of this nature could be of general benefit and if so, to develop methods of processing such data.

A nonunanimous consensus of the Committee is that the subjective form of icing forecast terminology (trace, light, moderate, etc.), should be replaced by quantified terms, e.g., LWC and OAT. It is also believed that installation of icing severity level indication systems, similar to those planned by the Army, upon commercial and other ice protected aircraft would benefit the National Weather Service and Air Force Air Weather Services in acquiring needed data for improvement of icing forecasts.

Design Criteria

Design criteria contained in FAR-25 and MIL-E-38423 are considered adequate for aircraft that operate above 10,000 feet. These criteria, however, are considered excessive for low/slow flying aircraft such as the military and civilian helicopters; many general aviation aircraft that rarely fly above 10,000 feet; close support, fixed-wing, military aircraft such as the A-10; cruise missiles; and remotely piloted aircraft. The U.S. Army, under R&D efforts, has developed meteorological design criteria for its helicopters. It is believed that these criteria would be suitable for any aircraft operating in the 10,000-foot and below altitude range.

It is recommended that a joint Government Agency reassessment of meteorological design criteria contained in the FAR's and MIL-SPECS be undertaken with respect to the various aircraft categories to recommend necessary or appropriate revisions. It is recommended that NASA lead this effort. Work performed in the development of Army helicopter meteorological criteria could be used as a basis. Three dimensional (3-D) Nephanalysis data may be suitable for confirmation purposes and should be considered.

Meteorological Data

The meteorological data base is considered inadequate for accurate forecasting, both in real time and for flight planning purposes, for determination of the frequency of occurrence of icing conditions and severity levels below 1500 feet, and for forecast modeling purposes.

To resolve this lack of meteorological data, the only solution is the acquisition of more data. The various data acquisition methods were briefly discussed and assessed, primarily in coordination with the Data Acquisition and Utilization Committee. Conclusions reached during these discussions indicate that more observations, either more frequently or more closely spaced, should be considered in combination with remote sensing of LWC and quantified pilot reports. The Aircraft Icing Committee could not establish the proper mix of data acquisition methods that would cost effectively resolve the meteorological data base problem.

It is recommended that this problem be addressed by NOAA and the U.S. Air Weather Service to determine the most cost effective method of filling the data needs and implementing the necessary programs.

SUMMARY REPORT OF THE
VISIBILITY COMMITTEE

N79-17426

Lt. Col. Robert L. Gardner

Air Force Inspection & Safety Center

Members of the Visibility Committee were:

Lt. Col. Robert L. Gardner, Chairman, AFISC/Flight Safety Div.

Larry Christensen, FWG Associates

Charles A. Douglas, Natl. Bureau of Standards (retired)

Arthur Hilsenrod, FAA

Ronald H. Kohl, UTSI

The committee meetings covered a wide range of subjects dealing with the various types of visibility and the terms used to express them, how each is obtained, and what some of the present and future limitations appear to be. In addition, the different aviation users were identified and an attempt was made to determine their needs with relation to visibility information. In the discussions with the floating committees, problems, improvements needed, and some possible solutions were expressed. Ways to develop a better understanding among the users, suppliers, rulemakers and researchers were also covered.

The following subjects represent our committee's efforts to prioritize the major issues developed.

1. The impact of automatic weather stations versus the traditional human manned station raised considerable concern. The following questions were of particular concern: (1) will sensors provide prevailing visibility? (2) can or will instruments give the needed data for forecasting purposes? (3) is there a justifiable requirement for prevailing visibility?

Discussions centered around the need for prevailing visibility and how instruments would determine it. We agreed there is a definite need for prevailing visibility or a suitable substitute. It affects General Aviation in a regulatory fashion and is used by the military in training and combat operations to determine Visual Flight Rule (VFR) requirements

and ~~Response Delivery~~ ~~Systems~~. For strict Instrument Flight Rule (IFR) operations, the aviation community could probably get along without prevailing visibility, but it does provide the pilot with helpful and useful information for flight planning and for terminal landing preparations.

It was pointed out that there are some 1,000 airports in the United States with approved IFR approaches, yet those fields do not have a weather observing capability. With this in mind and the possibility of another 300 flight service stations in jeopardy, it seems quite apparent that there is a justifiable requirement for low cost instrument systems which will measure ceiling and visibility.

The committee concluded that with proper safeguards, automatic weather stations can satisfy many of these requirements and service more locations without degradation.

2. The second most fruitful area deals with education and training. Aircrews need to have a clear understanding of the various visibilities, how they are obtained and what each is used for. The Airmans Information Manual, Part 1, Basic Flight Information and ATC Procedures, contains definitions of Flight Visibility, Ground Visibility, Prevailing Visibility, Runway Visibility Value/RVV, and Runway Visual Range/RVR in the glossary section. These terms and their applications need to be widely publicized.

In the area of training the new flight simulators offer great potential. Modern simulators can provide realistic reduced visibility training. Increased use of simulators and emphasis on instrument qualification should have beneficial effects on flight safety.

Our discussions disclosed that the capabilities exist to significantly improve reporting and dissemination of meteorology information. It was pointed out that pilots can and should exercise the PIREP to make inputs to the system. Inflight visibility is of particular interest to general aviation and pilot reports provide information that are helpful to others flying into the same area. Improvements are being made and FAA's En Route Flight Advisory Service (EFAS) and meteorologists in the Air Route Traffic Control Centers (ARTCC) offer significant opportunities to provide the aviator with better, near real-time weather information. To maximize the benefits from these systems, pilots, controllers and meteorologists must communicate and cooperate effectively.

3. The subject of slant range visibility generated lively discussions. There seemed to be a general consensus that there is a valid requirement for a system to determine slant range visibility. Support was expressed by the airline pilots, general aviation and military representatives.

783-1-1054
Research and development of a system to measure slant range visibility looks feasible and promising; however, at the present time developmental funds are being directed to higher priority projects. During this slowdown period some policy decisions should be made concerning the future use of slant range. Will it become a regulatory value used for minimums and replace RVR or will it be used in an advisory function?

The regulatory agencies, users, and producers of the information need to come to agreement in these areas before additional large amounts of funds are expended on the development of a technique which is not certain how and if it will be used. Certainly it appears that slant range would have to be used in conjunction with RVR to overcome the problem of shallow ground fog. We suggest that research continue pending decisions on future application. Funds to keep the program alive should be provided.

4. With twelve major airports planning to go to category II¹ operations, there is concern over the lack of weather data to determine the frequency of category III weather. Present RVR equipment does not indicate visibility below 600 feet RVR. The committee concluded that efforts should be continued to develop systems to reports visibilities in category IIIB approach conditions.

Users need to justify the requirements for automatic landing systems through category IIIC and most likely fog modification systems. Improvement will also be needed in visibility measuring equipment to provide RVR measurement below 600 feet and of less than the present 200 feet intervals.

5. In regard to visibility there are several design efforts which should be pursued. As category III operations are implemented a need for landing runway guidance once on the ground becomes necessary. Cockpit cut-off, particularly in jumbo jets, is a problem. Improvements in windshields' field of view, reduction of reflections, and visual properties are always desirable. Several conferees also expressed a need for cockpit eye-level position indicators.

N79-17427

SUMMARY REPORT OF THE LIGHTNING
AND STATIC ELECTRICITY COMMITTEE

J. Anderson Plumer

Lightning Technologies, Inc.

Members of the Lightning and Static Electricity Committee were:

J. Anderson Plumer, Chairman, Lightning Technologies, Inc.

M.P. Amason, Douglas Aircraft Co.

John A. Birken, NAVAIR/52026B

Maj. Phillip B. Corn, USAF/FDL/FEA

Joseph W. Stickle, NASA/Langley Research Center

Based upon discussions held among its own members and with each of the floating committees, the lightning committee assessed the status of lightning protection technology as applied to aviation, to ascertain the degrees of effectiveness presently being experienced with present technology, and identifying technology needs that remain.

It concluded that:

- An adequate lightning protection technology base and personnel with sufficient experience to apply it exist within the design organizations for most military and transport-category aircraft presently being built. Adequate formal, comprehensive standards and specifications, however, do not exist.
- An adequate understanding of lightning protection technology does not generally exist among designers of general aviation aircraft. Whereas lightning has not been considered a serious hazard to these aircraft in the past, greater use under IFR conditions has increased their susceptibility and the number of reported lightning strike incidents is increasing.
- Trends toward use of non-metallic structural materials, adhesive bonding techniques, and reliance upon sensitive electronics to perform flight-critical functions pose potential hazards for all categories of future aircraft unless new protection technology is developed, documented, and made available to designers.

- Pilots of all aircraft need a better understanding of the conditions under which lightning strikes can occur and the effects that it may have upon their aircraft. A better understanding will improve avoidance procedures, equip pilots to react knowledgeably when a strike occurs, and enable better information to be achieved from pilot reports of in-flight strike incidents.

Eight areas of technical need were defined. The nature of each problem, timeliness and impact of solutions, degree of effort required and the roles of government and industry in achieving solutions were discussed. With the realization that interrelationships exist among each of these areas, a priority of relative importance was assigned to each. A summary is presented in Table I, organized according to the outline presented at the workshop. A brief discussion of each need follows:

The Need for In-Flight Data on Lightning Electrical Parameters

The need is for a better understanding of the electrical parameters of natural lightning and of relationships existing between these parameters and effects that occur upon aircraft exposed to direct or nearby strikes.

This need stems primarily from the increasing reliance upon solid-state microelectronics to perform flight-critical functions, and from the replacement of conventional metallic structural materials with non-metallic composites. The next generation of aircraft is being designed to make widespread use of these new technologies to achieve improved performance and energy-efficiency goals, but increasing microelectronics sensitivity combined with harsh environments such as those produced by lightning requires special attention. In addition, unprotected composite materials are not able to conduct lightning-like currents without incurring severe loss of strength, and may also transmit high-strength fields from nearby discharges unattenuated into the aircraft interior.

There have been numerous measurements of lightning currents at the ground end of the flash, but very little information exists concerning the electrical characteristics at flight altitudes, and there is reason to suspect electrical characteristics (particularly in the nearfield), may be somewhat different than those measured on the ground.

Aircraft which are struck in flight, for example, nearly always become part of the conductive channel between the cloud and the ground. The manner in which this takes place was formerly thought to be rather unimportant, but recent evidence indicates that the capacitive charging current which occurs when the lightning leader first comes in contact with the aircraft may change fast enough to induce significant voltage in the aircraft's electrical wiring. There is no information, however, on the magnitude of the pre-breakdown currents which flow on an aircraft or the voltage they actually induce.

Similarly, there exists little information describing the electric field which surrounds the aircraft as the lightning stepped-leader approaches. The rate of change of this field determines whether or not dielectric structures such as radomes and canopies will be punctured.

In addition to data on the voltages and currents associated with the lightning strike itself, there is an associated need for time-correlated data on the voltages and currents induced by these strikes in typical aircraft electrical circuits. These data will enable validation of laboratory and analytical techniques for prediction of induced voltages in new aircraft.

Whereas direct strike parameters remain of primary concern, the radiated field effects from nearby flashes are also of interest as they may also interfere with sensitive on-board electronics and they statistically occur more often than direct strikes.

Attempts were made during the 1963-5 Rough Rider project utilizing an instrumented F-100 aircraft to acquire direct strike data, but instrumentation limitations permitted only a brief look at one of the return-stroke currents in the flashes captured by this aircraft and the data left many questions unanswered.

Advancements in digital data sampling, work processing and memory capability now offer greatly improved data-retrieval possibilities, and the committee gave strong endorsement to current NASA and USAF efforts at planning and implementing flight research programs in the 1979-81 time-frame to gather direct and nearby strike data.

Specific payoffs from improved lightning data were discussed, an included:

Improved safety, particularly through a better understanding of lightning interactions with aircraft electronics, enabling design of effective protection techniques.

More efficient designs, enabled by a better understanding of the real-world environment and development of national certification and test requirements.

Validation of verification test techniques.

The committee felt that useful data could come on-stream soon after the start of in-flight measurements, with an adequate statistical sample achieved after data on about 300 strikes were obtained, requiring a total of about 2-4 years of in-flight data gathering.

Technology Base and Guidelines for Protection of Advanced Systems and Structures.

The present need for lightning protection is most critical in the area of general aviation aircraft, which are being operated increasingly under IFR conditions. However the near future need applies to all aircraft making use of advanced technology systems and materials, and will be imperative.

Among these are an increased use of composite materials to obtain higher strength-to-weight performance, and the use of metal-to-metal bonding with adhesives in place of conventional fasteners (rivets) to obtain smoother outside surfaces and reduce drag, and to reduce costly hole-drilling and fastening operations. Other advantages offered by composites and adhesive bonding are reduction of corrosion and extension of fatigue life.

Active control systems implemented with microelectronic components offer great operational advantages and are likely to appear in derivative and next-generation aircraft. They must, however, be reliably protected against lightning and static-electricity induced interruption and failure.

These new technologies have already found their way into some aircraft now flying, albeit in mostly non flight-critical functions. Designers would like to employ these new technologies more extensively, but standing in the way of more widespread use are potential problems posed by environments such as lightning. Just as the entire structure must safety accept and tolerate the mechanical loads imposed by flight, it must also conduct electric currents produced by lightning and on-board systems, and conduct these through itself without degradation of mechanical integrity and without hazardous side-effects such as electrical sparking.

The committee noted that lightning currents must be concentrated more densely in the structures of small military fighter and general aviation aircraft than within those of transport aircraft, rendering protection of the smaller aircraft potentially more difficult. It was also noted that few documents exist to alert the manufacturers of these aircraft to possible pitfalls or guide them in protection design. Federal Airworthiness Regulations and military standards pertaining to lightning protection contain requirements that "---the aircraft be protected against the catastrophic effects of lightning", and that compliance be shown by "bonding components properly to the airframe", "designing components so that a strike will not endanger the airplane", "designing the components to minimize the effects of a strike", or "incorporating acceptable means of diverting the resulting electrical current so as to not endanger the airplane" but they do not offer many clues as to where the problem areas are likely to occur or what protection approaches to consider.

It was noted that some work sponsored primarily by the USAF, USN and NASA has been conducted to determine basic lightning effects on advanced materials, principally composites, but less work has yet been accomplished to learn how to assemble these new materials together in a structure capable of safely conducting up to 200,000 amperes of electric current in addition to meeting its mechanical load requirements. Similarly, little or no work has been undertaken to learn how to safely integrate fuel and electrical systems into these new technology structures.

The committee recognized the impracticality of expecting to avoid all lightning strikes, and noted that safety from this environment is obtained primarily by designing the aircraft to safely tolerate the strikes it receives, rather than by reliance upon avoidance procedures. The need for an adequate protection technology data base and practical design guidelines based thereon was therefore considered the central need, of which the other identified needs are in support.

Improved Laboratory Test Techniques

Improvements are needed in tests to evaluate two different lightning problems; induced voltage and blast effects.

Concern for induced voltages has been increasing with the advent of fly-by-wire flight controls and other systems which utilize electronics in flight-critical functions. Lightning strikes have already demonstrated an ability to disrupt aircraft electronics and the several trends in electronics and airframe design mentioned earlier may aggravate the situation further unless designers are aware of the lightning effects environment their equipment must survive in.

To permit this environment to be studied, a NDT technique called the lightning transient analysis test has been utilized. In this test, current pulses with waveforms similar to lightning strokes are injected through the airframe between typical lightning entry and exit points. The amplitude of these pulses is greatly reduced from that of typical lightning strokes, because pulse generators are not sufficiently powerful to circulate full-scale stroke currents through the aircraft, and full-scale currents may induce sufficient voltage to damage equipment aboard the aircraft. Voltages induced in the aircraft electrical circuits by these current pulses are measured and then, in most cases, extrapolated linearly to correspond with average lightning stroke amplitudes of about 30 kiloamperes or severe strokes of 200 kiloamperes. Linear extrapolation has been thought valid, but the use in practice of extrapolation factors of several hundred or so, and the surprisingly high voltages which these factors predict, have caused concern over the validity of linear extrapolation. The validity with which the technique simulates secondary effects such as traveling wave currents in the airframe and in the aircraft electrical cables themselves is one reason for concern.

Further laboratory research will be necessary to sort out cause-effect factors in the test technique, and in-flight measurements will be necessary to determine the validity of predicted induced voltages.

Concern over physical damage due to blast from the lightning channel has been intensified recently by several in-flight strike incidents which have damaged aircraft skins and access doors. No standard exists for simulation of blast effects, but laboratory tests using simulated lightning arcs were reported by one committee member to have duplicated in-flight damage, thus indicating that a standard test should be feasible.

Fulfillment of this area of need will best be achieved by parallel efforts at industry and government research laboratories, with correlation of results and definitions of standardized tests accomplished in government/industry forums such as the Society of Automotive Engineers (SAE) Committee AE4L on Lightning Test Techniques.

Analysis Techniques for Predicting Induced Effects

Committee members noted the desirability of having analytical tools with which to predict the levels of lightning-induced voltages in aircraft electrical circuits before hardware is built and available to test. To date, several attempts have been made to develop computerized models for this purpose but success has been very limited, due to inadequate understanding of the cause-effect relationships at work in specific situations. Here again measurements of actual strike data will help clarify these relationships and point the way toward improved analytical techniques.

Lightning Strike Incident Data from General Aviation

Information on the events that happen to an aircraft when struck by lightning is of value from several standpoints:

- a. to determine the flight and weather conditions under which strikes are likely, and
- b. to identify the surfaces on the aircraft where strikes are most likely (the attachment points) and the degree of physical damage occurring at the attachment points, and
- c. to identify other effects that occur.

These data, in fact, represent the most realistic lightning "test" data obtainable and should be studied carefully by designers alert for possible problem areas. The committee acknowledges the large store of lightning-strike incident data already being collected from airlines and the military, but as yet practically no such data has been accumulated for smaller, general aviation aircraft. A representative of the

Aircraft Owners and Pilots Association (AOPA) indicated the possibility of distributing a questionnaire to its members for their use in reporting strikes. Several magazines directed toward operators of general aviation aircraft have also shown an interest in publishing questionnaires. The committee agreed to pursue the AOPA prospect and try to have one of its members visit one of AOPA's "Cloud Nine" meetings in Washington, D.C. to discuss the project.

Lightning Detection Systems

Lightning detection systems are of interest as a means of alerting pilots to the presence of thunderstorm activity, and on the ground, as a means of alerting ground crews to approaching thunderstorms. The committee acknowledges that many aircraft can sustain lightning strikes with little or no hazard to flight safety and that a lightning detection/warning instrument would be of little value (assuming, of course, what weather radar was available to warn of the other thunderstorm hazards of rain, hail and turbulence). It was noted that some aircraft exist which are not well protected against lightning hazards and which therefore should take extra precautions against being struck.

Also, certain military operations such as in-flight refuelling should not be carried out when lightning strikes are likely.

Discussion continued on the types of lightning detectors presently available, with mention made of the Ryan Stormscope, an airborne instrument that processes spherics signals to determine range and bearing of lightning flashes, displaying them as dots on a CRT in the cockpit. The Stormscope will be flight tested by NASA and USAF (AFFDL) during 1978.

Several lightning warning systems for ground operations are available commercially. The need for such systems at airports was discussed but no consensus was reached regarding need since other means (radar) of detecting thunderstorms are often available.

Obtain Pilot Reports of Lightning Strikes

Judging from frequent pilot comments that "no thunderstorms were reported in the area" at the time a strike was received, many pilots are not aware of when strikes are possible. If pilots were to make verbal reports of strikes as observed, these reports could be relayed to other aircraft approaching the same area. For such a system to be successful, terminology to describe gradations of flash intensity and frequency of occurrence, etc. would have to be established and pilots would have to be educated in its use. The value of such reports would be improved avoidance of lightning strikes and thunderstorm areas.

Better Training in Lightning Awareness

If pilots had a better understanding of the conditions under which lightning may occur, what lightning is, and how it may affect their aircraft, they might be better able to react to a strike when it occurs. Several military aircraft accidents are reported to have occurred after pilots were stunned or blinded by lightning strikes. Flash blindness (which can persist up to a minute) may be impossible to avoid where there is only one pilot involved, but foreknowledge of the possibility may enable a pilot to avoid a mishap.

The committee discussed ways such training might be provided. Inclusion of it in pilot refresher courses and training manuals was discussed and it was suggested that the first few chapters of NASA RP 1008 "Lightning Protection of Aircraft" might be adapted for this purpose.

The committee noted that pilot training should also include the conditions under which lightning strikes may occur, since most pilots seem surprised to have been struck. Many consider these events "static discharges" because they are so certain lightning strikes will not occur along flight paths intended to avoid thunderstorms. Such training could also improve accuracy in reporting lightning strike events and in drawing conclusions from accumulated statistics.

TABLE 1
 LIGHTNING PROTECTION TECHNOLOGY NEEDS
 IN ORDER OF PRIORITY

	<u>1</u>	<u>2</u>
NEED	In-flight data on lightning electrical parameters a. direct strikes b. nearby strikes c. static electricity	Technology base and design guidelines for protection of advanced aircraft systems and structures
NATURE OF PROBLEM	Lack of data	Lack of design data, R&D
TIME REQUIRED	2-4 years	2-6 years
IMPACT OF PROBLEM	Uncertain test and design parameters	Increased safety hazards; decreased use of advanced technology
COST BENEFIT	Increased flight safety, especially under IFR conditions; quicker and more confident introduction of new technologies.	
EFFORT REQUIRED	New effort	Some knowledge in hand and major new effort required
PARTICIPANTS	Major role: government Supporting role: contractors	Government/contractors; improved data base airframe manufacturers; specific applications

TABLE 1
(cont'd.)

	<u>3</u>	<u>4</u>
NEED	Improved test techniques for: a. induced effects b. blast effects	Analysis techniques for predicting induced effects
NATURE OF PROBLEM	R&D	R&D
TIME REQUIRED	2 years	3 years
IMPACT OF PROBLEM	Increased hazards; decreased efficiency	More cut-and-dry
COST BENEFIT	Increased flight safety, especially under IFR conditions; quicker and more confident introduction of new technologies.	
EFFORT REQUIRED	Continued effort	Some new effort
PARTICIPANTS	Government & industry	Government & industry

TABLE 1
(cont'd.)

	<u>5</u>	<u>6</u>
NEED	More lightning strike incident data from general aviation	Lightning detection systems a. air b. ground
NATURE OF PROBLEM	Operational	R&D
TIME REQUIRED	1 year	2 years
IMPACT OF PROBLEM	Decreased reliability	Continued hazard to air/ground personnel and operations
COST BENEFIT	Increased flight safety, especially under IFR conditions; quicker and more confident introduction of new technologies.	
EFFORT REQUIRED	Additional reporting effort	Some new effort
PARTICIPANTS	General aviation industry	Government & industry

324-1-054

TABLE 1
(cont'd.)

	<u>7</u>	<u>8</u>
NEED	Obtain pilot reports of lightning strikes to aircraft	Better training in lightning awareness for pilots of all aircraft
NATURE OF PROBLEM	Operational and procedural	Operational and procedural
TIME REQUIRED	3 years	
IMPACT OF PROBLEM	Increased strikes	
COST BENEFIT	Increased flight safety, especially under IFR conditions; quicker and more confident introduction of new technologies.	
EFFORT REQUIRED	In hand, education needed	New
PARTICIPANTS	Operators	All

ORIGINAL PAGE IS
OF POOR QUALITY

N79-17428

SUMMARY REPORT OF THE
AIRCRAFT OPERATIONS COMMITTEE

Robert T. Warner

Aircraft Owners and Pilots Association

Members of the Aircraft Operations Committee were:

Robert T. Warner, Chairman, AOPA

Thomas Incrocci, USAF, Scott AFB

Ernest Schlatter, FAA, NAFEC

Art Vardado, FAA, Flight Standards

The floating Aircraft Operations Committee met with the fixed committees and had the following discussions:

Severe Storms and Turbulence

The areas of severe storms and turbulence appears to be full of new programs and a need for continuing education of pilot and air traffic service personnel. The new operational programs that are being introduced by the FAA and the National Weather Service should go a long way to improving both the strategic and tactical severe storm problem. The current major deficiency appears to be a lack of understanding on the part of pilots and controllers and how the information made available by these new programs will be utilized. This situation is complicated by the fact that air-to-ground communications is approaching the saturation point, particularly in the terminal areas. Further, we are currently in an atmosphere of post-accident finger-pointing, so many want the "other side" to take the responsibility for decision-making.

The committee's discussion indicated that there does not appear to be a crying need for additional turbulence information in the approach phase.

However, there does appear to be additional work needed in numerous areas:

1. Efforts should be initiated to revalidate old aviation forecasting techniques, including a look toward utilizing more advanced tools, such as satellite information and additional ground observation points. This may necessitate the proliferation of automatic observation

equipment. It appears that this revalidation work would be the proper function of NOAA and the military's weather services.

2. A cooperative effort must be undertaken to determine how we are going to put the great sums of information we currently have available to use in both preflight planning and in the cockpit. This effort must take into consideration present constraints including benefits, equipment, costs and pilot experience levels.

3. Additional cooperative effort is needed to expand education of pilots, controllers, and weather service personnel as to the capabilities and limitations of the other groups and to the intent and objective of the many existing and new weather programs.

4. There is both a civil and military need for more definition of the weather hazards in the vicinity of severe storms. This includes the detection of presence and severity of turbulence near thunderstorms. This effort might be best carried out through the federal government agencies that provide weather services.

5. There appears from the discussion to be a need for an information exchange and, where appropriate, a consolidation of effort between various government agencies working on the detection and hazards associated with clear air turbulence. This effort should continue the work which is ongoing in the detection of CAT at NASA Marshall and NASA Ames.

Icing

Currently, pilots without deicing or antiicing equipment have a requirement to know where icing is probable, and the degree of that probability. Terms describing the severity of icing as used in pilots' operating manuals, are assumed to be descriptions of ice forecasting as well as reporting terms. Discussion of the group indicated that there are no standard ice severity terms used for forecasting purposes.

There was also discussion of the ongoing Army research using phobic coatings on helicopter rotor blades, and the University of Dayton studies on the effects of frost.

There appears to be additional work needed in each of the above mentioned areas. The most pressing general aviation requirement is for a better definition for areas where icing is probable both in lateral and vertical dimensions, so that these areas may be best avoided. There may be a need for an improvement in icing forecasting terminology. This may come about as a part of the above mentioned requirements for revalidating existing forecasting techniques for today's airframes. The current work by the Army and the University of Dayton should continue, with NASA picking up the Army's results for testing to determine application feasibility for general aviation propellers and airfoil surfaces.

Visibility

Discussions with the fixed Visibility Committee indicated a continuing need for "prevailing visibility" until a reasonable substitute becomes available. This substitute may be, in part, the proliferation of automated weather observation facilities. The continuing need for prevailing visibility is both operational (required to determine forecasts) and legal (needed to determine between VFR and IFR).

Also needed is a cooperative effort to determine the methods that will be used to include more in-flight visibility information in the system. The tools for this are now available in both the FSS Flight Watch program and the soon-to-be-implemented meteorologists in the ARTCC program. A large source of information in the form of departing IFR aircraft is available for reporting in-flight (slant-range - air-to-ground) visibility, turbulence, cloud layers, tops and icing. Methods should be established by the FAA in cooperation with the users of the system to determine how best to collect and disseminate this information.

Minimal effort is ongoing by NASA Langley in the area of slant visual range for visibility approaches. Additional efforts by the FAA NAFEC have been recently halted for higher priority items. There appears to be a lack of understanding of these projects by the users, who should be ultimately making the decision on both the amount of effort in this study area and the eventual operational use of such facilities.

As a much longer range goal, discussion in this committee included the need for preliminary investigation of taxiway visual range for long-term future CAT III applications.

Lightning

Discussions with the Lightning Committee centered around the general lack of knowledge of general aviation experience with lightning strokes as to where, when and what happens, the pilot reactions, and the resultant damage to aircraft. There was a general consensus that there is a need for both joint government and industry effort to work toward gaining more information in this area which might ultimately result in education programs and the issuance of an FAA Advisory Circular. Some lightning information is already available in various documents, the most notable of which is "Lightning Protection for Aircraft," a NASA Reference Publication, #RP-1008, dated October 1977. It was encouraged that this and other available information be distributed and publicized in the immediate future by government and non-government agencies. It was pointed out that the military particularly, could benefit from accurate forecasting of lightning and electrostatic discharge. It is hoped that any work in this area inside or out of the government would eventually result in avoidance techniques applicable for both military and civil use. It was pointed out in this discussion, as in all preceding discussions, that there is a need for increasing pilot confidence in forecasting of all weather phenomenon.

General

Of the many areas discussed with the five fixed committees, the two most pressing needs appear to be procedural in nature. First, there is an urgent requirement for joint government and industry discussions on how best to use the information available today through existing and soon-to-be-implemented weather programs. These discussions must rank order priority the urgent and not-so-urgent information that is required for use by pilots and ground service personnel recognizing the many varying constraints.

Secondly, the need for education of pilots and ground service personnel is never-ending, and remains extremely high on the priority list of weather needs. Lack of reminders of old programs are among the most pressing needs to improve the effectiveness of weather programs.

Of a lower order of priority comes ongoing work on AV-AWOS, ALWOS and severe storm detection and avoidance technique development. Also in this priority category would come the need for revalidating old forecasting techniques on today's airframes utilizing modern tools with the ultimate goal of improving the users' confidence in forecasting.

George E. Cooper

NASA Ames Research Center

Members of the Human Factors Committee were:

George E. Cooper, Chairman

Richard L. Gilson, Ohio State University

A. Charley McTee, Bunker Ramo

Maurice A. Wright, University of Tennessee
Space Institute

Andy D. Yates, Jr., Air Line Pilots Association

Visibility

Reduced visibility as human factors problem was considered one of the most important areas discussed by the Committee in terms of the number of lives lost and cost in aircraft accidents and incidents. From a human factors viewpoint, the primary problem relates to the requirement for a pilot to estimate out-of-the-cockpit visibility at critical decision points in a flight. Despite modern measurement and dissemination techniques, there is a considerable variability in visibility data according to the time and place of the reported weather. Even the RVR provides only an approximation to slant-range visibility. Thus, the pilot is often forced to resort to eyeball determination for real time information. Without slant-range visibility techniques or category III landing capability, the problem is currently being attacked by improving training, e.g., by films, simulator, or inflight experience. However, in this regard, it is pointed out that training is too often relied upon in place of other solutions related to hardware improvements and other aids.

The chief human factors problems associated with those already mentioned are the reduction of visual cues needed for flight path control during the VFR segment of marginal visual flight or during low visibility approaches. The fact that natural horizon is lost during VFR flight or that an ill-defined portion of the "runway environment" during an instrument approach needs to be in sight in order to continue the flight or complete the landing, force pilots to perhaps optimistically estimate the visibility and continue to fly with a minimum of visual information. The result has been a tendency to descend dangerously low

to remain in visual contact or to increase rate of descent and land short because of having the illusion of going high during the approach to landing segment.

The solution, at the present time, lies in providing flight training experience with the actual or simulated conditions surrounding low-visibility flight and approaches. This requires accurate eye positioning, familiarization with the available visual information and ground cues, as well as familiarization with the specific cockpit cutoff angle of the aircraft being operated. It also requires pilot self-discipline and continuous monitoring of instruments during the VMC portion of the flight by the pilot or by other available members of the crew.

In summary, then, the experience gained through realistic simulation exercises involving such transitions from IMC to VMC, or VMC to IMC and the use of available information and cues is difficult to obtain. Responsibility for this training is at present spotty and rests primarily with the operators and independent training organizations.

Without special training, problems with out-of-the cockpit determination of visibility may be expected to grow in the future, not diminish. For example, with respect to helicopters, the current trend towards providing IFR capability might be expected to reduce current rotary wing approach minimums and to result in favorable benefits to the operators. Concurrently, however, we can expect many of the similar problems for helicopter pilots as occur with aircraft if visibility approach minimums are lowered. The pilot will be pressed into the same estimation of visibility and decision process with limited visual cues from the ground. The problem therefore, may be compounded by an increased rate of closure with the ground associated with the use of steeper approach angles for helicopters or require slower more difficult operating speeds. It should be pointed out that there is a slow speed limit for single engine helicopters, thus limiting slow speed approaches under IFR conditions in order to insure autorotation capability.

One solution to the training approach will include high fidelity visual simulation for the low visibility approaches. However, for optimum training value and cost effectiveness, it is highly desirable to identify and utilize those ground features which have maximal effect on a pilot's decision to continue to fly VFR or to land out of an instrument approach. Further research is also urgently needed in the area of advanced displays using electronic techniques for forward looking low light/low visibility T.V. images of the ground environment which could remove much of the dependence on training by providing additional visual information. In addition, flight path angle and groundspeed as a profile descent display could be beneficial

if they were readily available to the pilot via CRTs, heads up displays, or by new displays utilizing touch on the throttle or yoke controls.

Finally, the ability to supply slant-range visibility measurements particularly as an instantaneously available readout to the pilot is a worthwhile objective and continued R & D efforts should be expanded. Primary responsibility in these areas rest with NASA, NOAA, NWS or other government research agencies with a user input to the evaluation of such advanced techniques and displays.

Recommendations

A summary of recommendations includes:

- (1) increased use of low-visibility simulation in training,
- (2) research activities directed towards defining the features required for such visual simulation,
- (3) continued research towards developing forward-looking visual systems (TV, FLIR, etc.) for poor weather landings.
- (4) improvement of approach and descent aids and display techniques.
- (5) continued research and development for slant-range visibility measurement techniques or even the use of simple cockpit eye-position indicators in order to standardize visibility estimates. These recommendations should be followed up with the responsible organization for action.

Turbulence

Important human factors issues relating to flight through turbulence may be listed in the following order of importance:

- (1) Detection and avoidance techniques.
- (2) Pilot and crew procedures for handling increased workload and distraction caused by turbulence.
- (3) Aircraft handling techniques for safe flight through turbulence when it is encountered.

Education and training with respect to where turbulence may be found and expected, as well as recognition of clues indicating probable encounters, is fundamentally important for the following reasons. Such background is needed in flight planning to avoid reported or potential

areas at which encounters are likely in relation to cloud formation, jet streams and mountain waves. Inflight familiarity with visual clues which help to identify areas of turbulence during VMC operation. During IFR operation the availability and training in the use of weather radar or lightning displays are essential for avoiding the primary area of occurrence of severe turbulence, the thunderstorm. Last, with its characteristic unpredictability and lack of visible clues, clear air turbulence is an important area for which some type of technology-based warning is desirable. Continued government research (NASA, NOAA, NWS) and funded research by industry is needed.

Human Factors Effects on Pilots in Turbulence

It was noted that turbulence, ranging from mild to severe, provides proportionately increasing degrees of pilot distraction and increases in workload. Experiments show that sufficient whole body motion can disrupt thinking, decision making, and even visual access to information, whether from instruments or from air navigation manuals and charts.

One effect which was not significantly appreciated until the jet transport encounters during the 1960's was the startle effect of severe turbulence. During the initial research on the jet upset problem, it was determined that encounters with severe turbulence would be classed as a rare event for most pilots. Pilots with 20,000 and 30,000 hours have, in many cases, never encountered turbulence which would be classified as severe. This points out the desirability for providing training and experience in the physical aspects of severe turbulence in anticipation of this rare encounter. Such a procedure requires adequate simulation facilities being available. To date, such turbulence can be provided only by a few research devices.

Handling Techniques

While the desirability of training and experiencing severe turbulence was considered highly important, it is apparent that of even greater importance is the training of pilots in aircraft handling techniques when encountering severe turbulence. The emphasis placed upon attitude flying and proper thrust and trim procedures by means of training in recent years has largely eliminated the problems associated with such turbulent encounters. Such training includes an excellent FAA training film. To some extent this has probably been favorably influenced by the redesign and implementation of a turbulence mode for the autopilots, which provides a loose controlled attitude stabilization for the aircraft under severely turbulent conditions.

Finally, pilot awareness of turbulence frequency of occurrence, location and severity is an important human factor which requires continuing emphasis and attention. This is effectively accomplished during flight by the use of pilot reports, occurrence reporting and feedback to aircrews. Safety publications also recognizably play an important part in such a process. Articles, incidents, and other examples, publicized by airline or military safety publications, those of such organizations as the Flight Safety Foundation, AOPA, and others, serve to maintain flight crew awareness to these problems, not only of turbulence, but also of lightning, icing and severe storm encounters. The nationwide Aviation Safety Reporting System (ASRS) is also recognized as an important awareness factor in reporting and disseminating information which aids pilots and flight crews in maintaining a high degree of awareness in all of these areas. As noted through ASRS occurrence reports of all types, information transfer still remains the biggest problem in aviation.

Recommendations

Continued research and development leading to acceptable turbulence detection and avoidance systems should be strongly encouraged. Unfortunately the reliability of current detection devices under development is not extremely high. The ultimate question may rest with human factors decisions as to "what is an acceptable false alarm rate?" Both the current use of present turbulence detection devices as well as their ultimate utilization can be significantly affected by this question.

With respect to turbulence forecasting, there is a continuing need for greater accuracy. A high false alarm rate can lead to distrust and disregard by flight crews. A pilot-in-command will reconsider the consequences of repeated actions such as turning on seat belt lights, terminating food service, taking large diversions to miss or avoid potential turbulence areas, or even the inconvenience of a change in heading or altitude when such precautions prove repeatedly to be unwarranted.

Simulator Turbulence Modeling

It was agreed by the committee that turbulence modeling for simulators needs improving and that these improvements should be possible. Yet, it was also recognized that there are realistic and practical limits to the displacement of motion systems for simulator and that these limits contribute perhaps insolvable problems to true motion fidelity for simulators under all conditions. It was suggested, therefore, that perhaps distinguishing between acceleration (motion) as a cue and turbulence as a distraction could perhaps establish separate objectives for the degree of fidelity required for different tasks. Under normal conditions, aircraft handling requires the highest degree of dynamic fidelity because the pilot makes definite use of the cues provided through motion in performance of his task and obtains an associated

reduction in over-all workload. It should be noted, however, that false cues from washout circuitry need additional attention. The distraction resulting by turbulence, on the other hand, whether mild or severe, in effect disrupts and overshadows these dynamic cues effects which might otherwise be of assistance to the pilot in reducing workload. At present, the short period lateral and normal accelerations associated with light to moderate turbulence are not genuinely reproduced. Added realism would be provided by better reproduction of these. However, considering higher levels of turbulence, where the distraction becomes significant, it is questionable whether the attempts to achieve maximum fidelity might not be overshadowed by the need to concentrate more on the distractive nature and severity of turbulence through reasonable approximations. The Committee recognizes that improvement in simulator motion modeling is the responsibility of NASA primarily, and other government-sponsored research.

Icing

The prepared presentation and information provided by the icing resource committee tended to indicate that icing technology had achieved solutions to most of the icing problems for heavy aircraft nearly twenty years ago, and little work has proceeded since. Currently design efforts apparently are devoted to helicopters and the requirement to enlarge helicopter operating capabilities to include IFR flying and the associated weather penetrations.

While many aircraft icing technology problems have apparently been solved, the committee did not feel that this is true from a human factors point of view. Several examples were reviewed which indicate that continuing education and training are and will be necessary with respect to icing problems on aircraft.

The first deals with simple pitot static icing which, despite simple prevention techniques, is consistently associated with weather-related accidents. The problem appears to be one where pitot-static icing indications are misinterpreted by the crew who as a result take inappropriate action.

The second is that icing effects have been blamed for a great deal of malfunctioning of avionics components. From the discussion with the icing committee, it became apparent that many, if not all of these accounts, were probably due to structural ice forming an insulating layer on the antennas and that education of flight crews as to the degrading effects of structural ice on communications and navigational signals is needed.

Third is carburetor icing. This was noted to be still a major cause of general aviation engine malfunctions and accidents. It is necessary for pilots to be aware of conditions which requires a decision that can be isolated, infrequent, and sometimes based on apparently

contradictory information depending on type of aircraft and flight conditions. It was noted with respect to the latter, that there is a lack of standard procedures in this regard, even among aircraft manufacturers, Federal agencies, and other organizations. The problem, therefore, points strongly toward the possibility of introducing a cockpit warning and alerting system based upon the use of some type of ice detection technique. From a human factors point of view, such an indicator must have a high degree of reliability, otherwise it is apt to become a distraction in the cockpit and to be ignored when it is needed. Another solution discussed was the possibility of a fuel additive which could perhaps minimize or eliminate the possibility of carburetor icing. Other possible solutions lie in the area of protective coatings in strategic engine area to discourage ice formation. The use of a fuel additive could be a solution to the problem if all aviation fuel designed for carburetor-type aircraft was so modified. This is, however, possibly influenced by economic restraints. If optional fuel with the additive is provided, then the possibility of occasionally not finding the applicable fuel could introduce human factors problems in terms of an awareness of the hazard. A system of adding an additive by the operator, as is now used with jet aircraft not having fuel heaters, is also a potential solution.

With respect to these areas, there remains a continuing need for information and training into the recognition and appreciation of the effects of icing. The FAA would seem to be the organization to seek some standardization of procedures, e.g., in the application of carburetor heat, as well as the use of a fuel additive to prevent carburetor icing. The possibility of providing required research for ice detection and warning should be primarily NASA's responsibility, with a requirement for FAA's support and/or other government support of R & D efforts.

Helicopter Icing

It was apparent that there is currently significant interest in extending the operational envelope of helicopters by providing them with necessary icing protection. Helicopters rotor performance is more susceptible and further degraded by icing conditions under certain conditions of liquid moisture and temperature than are components of conventional aircraft. At the moment, this appears to necessitate development of an indicator/warning system to advise the pilot that he is entering conditions of liquid moisture and temperature susceptible to icing. The fact that these dangerous conditions can occur for which protection is not afforded leads to the conclusion that continued safe operation for current helicopters into icing is questionable. At present, therefore, helicopter operations in icing conditions must be terminated unless there is atmospheric information available to the pilot which provides him with knowledge of an escape route through, e.g., an altitude change. Can similar operations be authorized for helicopters?

Lightning

Again, from a human factors point of view, the pilot's primary concern is avoidance of lightning if at all possible. It is recognized, however, that at present, the only way of avoiding areas of lightning is through the recognition and circumvention of thunderstorms, either by visual means, by use of weather radar, or perhaps by lightning detectors (stormscopes). Lightning strikes can also be encountered when flying between layers of clouds or between clouds and the earth. As far as hazards are concerned, pilots should be made aware that if lightning strikes are encountered, they typically will result in only minor damage to the aircraft, however, they also should be aware that lightning strikes are also primarily associated with the turbulence hazards of thunderstorms.

All associated problems will occur if the pilot happens to be looking in the direction of the lightning flash. The solution to this problem lies primarily in education and crew training to insure that at least one set of eyes remains in the cockpit, on instruments, during penetration or proximity to thunderstorms or reported areas of potential lightning. The importance of knowing in what situations strikes can occur should be emphasized along with new techniques for detecting or forecasting localized lightning. A partial solution would be in familiarization of pilots with the various types of lightning, e.g., through the use of appropriate visual aids, as a means of preparing pilots for the rare event of a lightning encounter.

The human factors committee received a thorough review of design problems associated with lightning. While these are consistently applied in the design of current metal aircraft, there appeared to be less consistency as well as appreciation of the problems regarding the adverse effect upon digital electronics and the design of fiberglass components. The transfer of design information to maintenance and overhaul personnel is also needed. The loss of bonding during overhaul or major maintenance and repair can increase the chance of lightning damage of various components. Finally, the development and dissemination of guidelines and specifications for aircraft design utilizing various plastics appears to be an important step, if the human factors concern of flight crews is to be alleviated.

The problem of high-speed refueling, leading to static electric charge build up was discussed and still appeared to present safety problems, even with the new foam-lined tanks provided in some military aircraft. While further research and development appeared to be required in new technology areas for solving this problem, the primary requirements for solution remain in the area of training in techniques of fueling and the use of fuel additives. Responsibility here lies primarily with the user organization, either military, airlines, or in the private/public sector.

The potential for encountering lightning strikes or severe turbulence during the approach phase of flights when under ATC guidance presents another human factors problem. Great concern has been voiced by pilots when under ATC guidance, they realized they might be vectored into an area of severe turbulence or potential lightning strike because of inability of ATC to simultaneously scan weather and control traffic. This situation has resulted from developments for approach control radar which minimize the weather shown and thus controllers are unable to identify hazardous areas. A new procedure, being initiated shortly in which weather radar and a forecaster are assigned to each ARTCC, should be of significant help.

Severe Storms

Windshear on the approach appears now to be recognized as one aspect of a severe storm. The decision of turbulence, icing and lightning also generally applies to the thunderstorm, which is perhaps the most prevalent of the severe storm hazards to aircraft.

Windshear: Windshear associated with a sharp frontal system and windshear on final approach were the two conditions discussed.

The primary problem from a human factors point of view is the lack of recognition and ability to avoid these areas by most pilots. This is due either to lack of detection of the phenomenon and/or the lack of communications regarding its occurrence. Obviously, with regard to the latter any delay of information about a "severe storm" in reaching the pilot adds further delay to his ability to initiate any corrective action in time.

Solutions: Continued development of instrumentation, enabling the detection of windshear phenomenon is necessary. This information must also then be transmitted to the pilot in usable terms. For example: "expect 15 knots airspeed loss." Secondly, it is important that one crew member continue the monitoring of airspeed, flight path and rate of descent during the approach; thirdly, additional cockpit information which reduce delays in initiating action, such as flight path and groundspeed should be provided directly to the pilot in a rapid fashion, e.g., a head-up mode or even alerting displays by touch.

In summary, consideration must be given to what information is needed by the pilot in order to make the decision of whether to land or to go around. It may be important, for example, (1) to provide more information on preceding occurrences; (2) to provide exact information relative to gust intensity; (3) increasing the speed of the information loop by providing flight path angle, groundspeed, or detecting information in a head-up or tactical mode; (4) insuring monitoring and takeover procedures; and (5) providing suitable training experience by use of simulation that includes such items as proper thrust management and use of available information.

88-1-154
Dissemination of Information to the General Aviation Public

A significant problem area with many of the above hazards appears to be associated with the fact that many general aviation aircraft have no weather radar or means by which sophisticated on-board weather detection devices can be installed. Further, many of these pilots have little contact with ATC and rely mainly on preflight and inflight contact with flight service stations for weather information. The dissemination problems in providing current weather to these pilots is further intensified due to the anticipated large increases in the numbers of private pilots in the future. Moreover, single pilots in general aviation aircraft often find it difficult to use the additional frequencies often required to obtain information relative to weather and severe storms. Finally, single pilot observation is at times insufficient, for example, VFR pilots often cannot see thunderstorm buildups due to extensive haze in the area. In summary, there is a distinct difficulty for a large portion of general aviation pilots to take advantage of possible benefits from the new Center weather radar and forecaster plans.

Solutions considered during the discussion include (1) the provision of severe weather information along with traffic control communications, (2) use of dedicated frequencies for SIGMETS and AIRMETS (due May 5, 1978), (3) better dissemination of information regarding severe storms, e.g., through the expansion of en route flight advisory service, and (4) providing general aviation aircraft with low cost, ground repeater radar information for weather and traffic displays to bring them the same information that is available to ATC.

Responsibility

Responsibility for improved information dissemination rests primarily with the FAA with, of course, shared responsibility with NOAA and NWS. Solutions for many of the unique problems of the general aviation pilot lie with NASA's general aviation program and the funding of new technology. Development, testing and evaluation of low cost repeater radar capability should probably be by government funded research and NASA evaluation with user input.

SUMMARY REPORT OF THE
AIRCRAFT DESIGN COMMITTEE

N79-17430

John T. Rogers
Boeing Commercial Airplane Company

Members of the Aircraft Design Committee were:

John T. Rogers, Chairman, Boeing Commercial Airplane
Company

Edward Blick, University of Oklahoma

Nigel Gregory, British Defense Staff

John C. Houbolt, NASA Langley Research Center

Richard L. Kurowski, NASA Ames Research Center

Lt. Col. John A. Lasley, Jr., Aeronautical Systems
Division, USAF

As is the case of the other "floating committees", this committee held meetings with each of the five fixed committees. Since the background of each of the committee members was different, and in some cases none of the committee members had specific backgrounds in the particular subject for that meeting, the inputs from the design committee varied considerably from meeting to meeting. In all of the meetings the committee feels that the discussions with the other committee members contributed substantially to our understanding of the subject areas discussed.

Summaries of the discussions with each of the five fixed committees are presented in the following sections.

Lightning

None of the members of the design committee considered themselves expert in the field of lightning, and the discussions by members of the lightning committee were particularly useful in improving our overall understanding of the basic design problems. As a result of these discussions there was a general consensus that R&D efforts should be aimed at 4 major areas:

- (1) Understanding the basic laws defining the lightning phenomenon.
- (2) Development of modeling techniques adequate to represent both the aircraft structure and systems.
- (3) Validation of (1) and (2) above.
- (4) Dissemination of this information to all design groups. The committee feels that this is a major point. Currently the major manufacturers have, at considerable expense, developed both analytical and test techniques adequate for design, but these techniques are not widely known throughout the industry.

The increasing use and dependence on sophisticated electronic systems and the use of composite structures demands that the work of (2) and (3) be accelerated and that it take into consideration the newer electronic systems and composite structures.

It may be possible to obtain some of the needed information by installing additional instrumentation on the weather reconnaissance fleet currently operated by the U.S. Air Force. It is recommended that consideration be given to such a program.

In discussing the overview paper presented by Major Corn entitled "Overview of Lightning Hazards to Aircraft", concern was expressed at the apparent increase in storm related mishaps. However, the data presented did not permit any interpretation of the causes or nature of these mishaps. The committee believes that in order to be useful in attacking the source of the problem additional information describing these mishaps is required. It is recommended that every effort be made to define and classify each of the incidents reported as to type of operation, operating environment (day, night, storm penetration, etc.) and nature and extent of the mishap. A more thorough understanding of these mishaps could lead to either design or operational approaches to reduce the number of mishaps.

Severe Storm

1. The meteorological scientists requested that the aircraft design and operation engineers define the necessary wind shear parameters and levels that are critical for operation of the airplane on approach or takeoff, in order to guide programs to develop both ground and air based measurements to alert pilots of potentially dangerous wind shear operations. The aircraft design committee suggested that pilots should be warned when wind shear levels approach a threshold level of about 3

knots per 100 feet vertically. It is also extremely important that the pilot be warned at least one minute prior to encountering the wind shear irrespective of the level.

2. Both committees felt that increased efforts and studies to optimize piloting techniques for operation in previously undetected wind shears should be undertaken, and the results of these studies widely disseminated throughout the industry.
3. Mr. Lee discussed a current program undertaken by NSSL to evaluate the effectiveness of X band and C band radar to determine the severity of storm cells detected by radar. This is essentially a re-evaluation of earlier information which is permitted by increased computing capabilities available today. The two committees recommended that this study should include the trade-offs in terms of weight, radar dish size, cost, and effectiveness of the two radars in defining the severity of storm cells. If significant differences in capability of effectiveness are apparent then this information should be widely disseminated throughout the industry.
4. An evaluation by NASA of the Ryan Storm Scope used to detect lightning occurrences in relation to avoiding severe storm cells was discussed. There were various comments in relation to its value with no general consensus of opinion, except that the scope is not a satisfactory replacement for weather radar.
5. There was a general feeling that current gust criteria are adequate for design when reasonable storm avoidance techniques are used.

Turbulence

No major deficiencies exist in accounting for turbulence in aircraft design. However, there are several areas in which the design committee feels fruitful activities should take place. The committee would assign first priority to the development of satisfactory on-board sensors for detection and warning prior to the encounter of clear air turbulence en route, and for either on-board or ground phased detection and warnings systems of dangerous wind shears during landing and take-off phases of aircraft operation. CAT encounters still constitute a hazard for potential injury to both passengers and flight attendants, and the undetected wind shear problems can result in disastrous piloting problems. In addition to providing sensing devices, the committee feels that strong training programs should be developed for flight crews to enable them to detect previously unreported wind shears as early as possible and immediately take the appropriate piloting action.

In the design area, the committee feels that additional consideration and development work should occur in the following areas:

- (1) The effects of spanwise gradients of gust velocity may have significant effects on the controllability aspects of design and should receive further study.
- (2) The committee feels that while the power spectral density approach to accounting for continuous turbulence for both structural and flight controls design is a useful tool, discrete gust design considerations should not be neglected. Approaches such as that proposed by Glynn Jones of the RAE should continue to receive some consideration. The committee further feels that the mission analysis approach of gust design may be useful for consideration of unique operating modes of military aircraft, but is not an appropriate tool for the design of commercial transport aircraft and the changing strategy and technology of military aircraft makes even military application questionable. We feel that the mission analysis approach is unsatisfactory to represent the large variables involved in worldwide operation of military or commercial transports, and that structural design should be based on the design envelope or critical condition approach.
- (3) The committee strongly endorses the planned NASA program to re-instate and expand the earlier VGH program for obtaining statistical data from commercial airline operations.
- (4) Workshops in which the aircraft engineers could meet with meteorological specialists to provide to the meteorologists a more detailed understanding of the meteorological data needs of the engineer in handling the problems of design and operation of aircraft in turbulence would aid greatly in directing the research and development work which needs to continue.

Icing

Until recently research in the area of icing has been neglected over a rather long period. Icing problems on helicopters and small aircraft, in particular, should receive additional attention from the aviation community. The U.S. Army is currently contributing substantially to knowledge in this field. Based on Army studies of design criteria, it appears that current criteria contained in FAR 25 may be too conservative for some classes of light aircraft and helicopters, and it is recommended that FAA review the data used by the Army in establishing their current criteria, and consider revising their criteria in line with the Army proposal.

In the area of testing and certification, there is a strong need for a thorough study to determine the most effective tools for completing certification testing. It appears that considerable expenditures may be involved in developing the required facility improvements, but the cost effectiveness of using the various test facilities should be thoroughly examined. The study should cover:

- Analytical Modeling
- Wind Tunnel Simulation Testing
- Wind Tunnel Icing Tunnels
- Ground Test Rigs
- In-Flight Tanker Testing
- In-Flight Natural Icing Tests

Visibility

The committee feels that contributions of the aircraft design community to improvements in the area of visibility are limited to a few specific areas. They are:

- Continue efforts to improve windshield design from the standpoint of visibility in all weather conditions.
- Development of landing and ground operation systems for operation in conditions of zero-zero visibility.
- Design improvements to assist the pilot in transition to and from instrument to visual operation. This involves such areas as improved lighting systems, heads up display, etc.
- Improvements in instrument display systems for faster interpretation by the pilot.

SUMMARY REPORT OF THE
WEATHER SERVICES COMMITTEE

N79-17431

Loren J. Spencer

FAA

Members of the Weather Services Committee:

Loren J. Spencer (Chairman), FAA

Bob Bell, FAA

Harry L. Burton, FAA

Edward M. Gross, NWS

Ernest A. Neil, NASA Goddard Space
Flight Center

Charles H. Sprinkle, NWS

Terms of Reference

The frame of reference for deliberations by the Weather Services Committee encompassed the provision of weather services to a wide range of users of the National Aviation System (NAS). Our discussions focused primarily on weather services related to severe storms, turbulence, icing, visibility, and lightning. The discussions were active and detailed to the extent permitted by the limited time spent with each of the fixed committees. Each of the weather phenomenon areas was explored through discussion in the terms of needs, problems related to providing services, and availability of timely and appropriate information. Considerable emphasis was placed upon the development of specific recommended actions to improve weather services to users of the NAS.

Significant Problem Areas

1. The measurement of slant range visibility is a serious problem which needs additional emphasis.
2. Accurate forecasting and appropriate reporting of lightning appears to be beyond the present state-of-the-art and should receive additional research and development effort.

18-0501-050
3. It is the consensus of all of the fixed committees participating in the meteorological and environmental workshop that the state-of-the-art has not provided adequate sensors to measure some weather elements such as ceiling, prevailing visibility, and precipitation.

4. A large number of users of the NAS lack knowledge and understanding of weather information which is available -- how to obtain it and how to use it.

5. The Weather Services Committee recognized that the current trend in Government to reduce manpower in the agencies involved in our area of concern will have serious impact on most of the recommended actions which we support. Therefore, we have exercised the utmost caution in our consideration of sophisticated programs or projects to enhance weather services.

6. Funding constraints for the agencies and/or activities involved in carrying out our recommended actions will have significant impact and in most cases additional funding probably will not be available.

Recommended Actions

Suggested action agencies are indicated after each action item.

1. There is an urgent need to improve the capability to forecast icing conditions -- additional effort should be devoted to the use of model application. (NWS)

2. Investigate the feasibility of providing runway visibility range (RVR) trends. (FAA)

3. Develop sensors to measure slant range visibility from cockpit to ground. (FAA/NASA/DOD)

4. Investigate the elimination of the need for the continued use of prevailing visibility. (FAA/NWS/DOD)

5. Design precise and descriptive terms for reporting lightning conditions and obtain more frequent pilot reports of lightning conditions. (NWS/FAA)

6. Develop and carry out a program to educate users of the NAS concerning the availability and use of weather services information. (NWS/FAA)

7. Develop better instrumentation for the detection of gust front, down burst, and non-convective low level wind shear hazards and apply this information in the development of forecasting techniques. (NWS/FAA)

8. Due to the scale of aviation weather requirements, a greater emphasis must be placed upon research in meso-scale modeling and forecasting technique development. This effort would involve all agencies supporting or providing weather services. (NOAA/DOD/NASA)

9. Develop a Federal plan for aviation weather services and supporting research under the auspices of the Federal coordinator. (DOT/NOAA/DOD/NASA)

10. Improve and extend the EFAS communications capability ground to air for both low and high altitude operations. (FAA)

Conclusions

The Weather Services Committee members were unanimous in the opinion that the workshop served a useful purpose and should be continued as an annual forum to identify problems, to discuss related issues, and to recommend specific actions needed to improve weather services for users for the NAS.

SUMMARY REPORT OF THE **N79-17432**
DATA ACQUISITION AND UTILIZATION COMMITTEE

Mikhail A. Alaka

National Weather Service

Members of the Data Acquisition and Utilization Committee were:

Mikhail A. Alaka, Chairman

Bruce L. Gary, Jet Propulsion Lab.

Lloyd C. Parker, NASA Wallops Flight Center

Frances Parmenter, National Environmental
Satellite Service

Robert J. Roche, Federal Aviation
Administration

Robert Steinberg, NASA

Joint Sessions with Fixed Committees

This committee held joint sessions with each of the five fixed committees and discussed data acquisition and utilization in terms of their respective areas of responsibility--turbulence, icing, visibility, lightning, and severe storms. Discussions revolved around three main aspects:

- a. The capability to generate the data;
- b. Data collection and reduction; and
- c. Data dissemination and distribution.

Following is a summary of the points made during the joint sessions in connection with the above three components.

Generating the Data

There was a general consensus that present capabilities to generate information on atmospheric phenomena adverse to aviation need to be enhanced. These capabilities may be:

- a. Primarily for detecting the adverse atmospheric phenomena, or
- b. Designed to shed light on the nature of these phenomena.

~~SECRET~~
The major concern expressed during the meetings was for the current inadequate detection capability. There was general agreement that a system of sensors is needed for the detection and characterization of:

- low altitude wind shear
- severe clear air turbulence
- lightning
- severe thunderstorm conditions.

The near term objective would be to equip terminal areas with an improved detection capability. In general, this would be possible with current technology; a longer term objective would be to develop the capability to equip aircraft with light, relatively inexpensive detection sensors. The perhaps overly optimistic view was expressed that eventually a single unit could be developed which would be capable of alerting pilots to the imminent danger of encountering any of the above phenomena. This is not attainable with current technology, and research is needed before such a unit could be developed.

Glide path wind shear measurement systems are under development, and near future deployment at major airports is a reasonable expectation.

Severe turbulence in clear air, or near cirrus clouds cannot yet be reliably forecast with aircraft warning systems, although several systems and concepts are under evaluation.

General aviation as continuing and critical need for prevailing visibility data. The projected closing of Flight Service Stations (FSS), coupled with the shift toward systems automation, establishes a clear requirement for a sensor system to provide this information reliably and automatically. There is also a need for an instrument system with scanning capability to measure visibility in the direction of the glide path, a day-night capability to determine slant range visibility, and a low cost day-night ceilometer. Low-cost automatic weather stations using such sensors are needed at over 1,000 general aviation airports which have published IFR approaches but which currently have little or no weather observation data.

Currently available sensors, with some modification, appear to be adequate for airborne measurements of lightning. The Electronic Counter Measurement (ECM) sensors should be evaluated as a potentially advanced technique and source of additional data.

With regard to icing, instruments for flight tests and certification are apparently adequate; but new, less expensive, and lightweight sensors

are desirable. Opinion was divided on the measurements needed for ice detection and forecasting. It was apparent that requirements for general aviation were less stringent than those for helicopters and for combat operations. The opinion was expressed that to describe and forecast icing intensity in meaningful, quantitative terms, measurements of liquid water content, drop size, and ambient air temperature will be needed. Low-cost and accurate sensors need to be developed to measure these quantities remotely from the ground or in situ from the aircraft.

Data Collection and Reduction

There is a need for the collection, reduction, and storage of various types of data which have a bearing on the safety of aviation. Following are some of the requirements discussed during the joint sessions:

a. Turbulence. At present, major sources of turbulence data are the VGH program of Langley and the MAT spectral analysis program. There is a need for comprehensive, world-wide records of average and "worst case" turbulence and shear events at different altitudes in different seasons. These would help in aircraft design and in analyzing human and automatic control systems response to turbulence.

There is a need for improvements in forecasting clear air turbulence so that costly flight deviations can be minimized. To this end, more information is needed on the synoptic and sub-synoptic preconditions for clear air turbulence. Low-level wind shear data associated with CAT conditions would be helpful.

b. Icing. For better forecasting of the incidence of icing conditions, a comprehensive data base for icing events below 1500 ft is needed, together with the concomitant meteorological conditions -- liquid water content, drop size, ambient air temperature, ..., etc.

c. Visibility. There is a lack of data on the occurrence of Category II (CAT II) and Category III (CAT III) weather, down to 300 ft RVR and below. These data are needed to establish the frequency of marginal landing conditions at airports.

Past cost/benefit analyses have been based on assumptions regarding the number of hours of occurrence of very low visibility at specific terminals. These assumptions have been translated into the number of air-carrier flights that could be completed without diversion, thereby providing the basis for benefits. In fact, the potential number of CAT II and CAT III landings may be below that postulated, because it is common for some element of the total system (ground nav-aid or lighting system, aircraft avionics, flight crews) to be out of operation.

More accurate analyses are necessary to develop the proper trade-offs before launching on the development of improved systems, such as automatic landing and taxiing systems, improved lightning systems, and fog dispersal systems.

The primary data necessary for proper trade-off studies would be accurate records of occurrence and duration of CAT III data down to zero visibility in 100 ft RVR increments. Deployment of transmissometer equipment, more sensitive than present equipment, which measures in 200 ft intervals, is required. This, however, does not present any technical problem. At least one set of this equipment should be deployed at up to 20 of the most active terminals which experience CAT III weather with reasonable frequency, together with recording equipment for data acquisition and storage.

d. Lightning. There is a need for airborne measurements for improved characterization of lightning strikes. A survey is also needed to determine the effect of lightning strikes on aircraft. A possible source of assistance to accomplish this survey may be the National Business Aviation Association and Aircraft Owners and Pilots Association.

e. Severe Weather. The importance of severe weather to aviation and its multifaceted manifestations have made it imperative to embark on data collection programs which would facilitate research into the nature and prediction of the phenomena. Because of the mesoscale nature of the trigger mechanisms and processes involved, high resolution observations are required. To meet this requirement, NOAA's National Severe Storms Laboratory (NSSL), has established an annual data acquisition and collection program which is carried out in Spring, in collaboration with other interested agencies. A much more ambitious data collection and research program, known as SESAME, has been designed but has languished because of lack of funding support. A more modest version of this project, known as "Little SESAME" is now being considered for implementation with existing resources.

Because of the great impact of severe convective weather on aviation, it would appear reasonable that aviation interests lend their support to data collection programs such as SESAME.

Data Dissemination and Distribution

In terms of data acquisition, one of the ironies that has been highlighted in this workshop, as well as in the past by many user organizations, is the abundance of real-time weather information that is always available somewhere in the national airspace system -- either the cockpit, in en route ARTCC's, in terminals, or in flight service stations. However, the means on the part of servers and users to access this information is totally inadequate.

The problem stems from both an absence of organization to maximize the distribution of this information in today's environment, and the constraint imposed by the lack of modern digital communication systems, and automated data retrieval and display systems.

The FAA has several programs underway that address both aspects of this problem.

a. The FAA has recently implemented an improved service in Flight Service Stations (FSS) called Enroute Flight Advisory Service (EFAS). Some forty EFAS positions have been established in FSS's across the country, providing a dedicated air/ground radio frequency for the purpose of collecting and disseminating pilot reports (PIREPS). This frequency is not used for normal air/ground communications, i.e. filing flight plans, position reports, etc., but is dedicated to soliciting and disseminating information on weather being encountered by pilots using the airspace. Pilots can monitor this frequency and keep informed of the real-time weather along their route of flight.

This program calls for providing weather radar information, satellite photo information, and other aids to the EFAS specialist to aid in the acquisition of the best information available in the system today. Most EFAS sites have not yet been equipped with the required equipment, and continued emphasis is needed to assure that this supporting equipment is provided.

b. The current data distribution retrieval and display systems are obsolete (Service A teletype circuits) and inadequate. Several programs address this problem:

1) The FAA is acquiring a new, modern digital communications system, identified as the National Digital Communications Network (NADIN), which will replace the current Service B network and eventually most, if not all, of Service A. This system will permit the rapid dissemination of data between Air Route Traffic Control Centers (ARTCC's), terminals, and FSS's.

2) The Flight Service Station Automation Program will provide modern digital (alphanumeric and graphic) data retrieval and display capabilities to the Level III (43 busiest) FSS's. This system will be implemented beginning in approximately three years. Computer systems located in the ARTCC's will contain a complete aviation weather data base, including AFOS graphic products, and will generate displays in the FSS's. The system will also enable pilots to directly access the data base for self briefing, using terminals ranging from the common keyboard and CRT display to the simplest device -- a push button telephone pad for input and automatic voice response for output.

3) The FAA & NWS are currently (April, 1978) deploying meteorologists in the ARTCC's for the purpose of providing short term forecasts and information on hazardous weather. Eventually, AFOS equipment will be provided in the ARTCC's for their use, and

displays will be provided to controllers in the en route sector (at ARTCC's) and to controllers in TRACONS and towers. The FSS computer system will probably be used to drive these displays.

Therefore, in three to six years, the capability will exist to rapidly acquire process, communicate, and retrieve and display real time weather, in alphanumeric and graphic forms. This will eliminate the major problem in making the abundance of information available in the system today more accessible.

On a more futuristic note, as the FAA begins to implement DABS (Discrete Address Beacon System), a digital link will be established between airborne aircraft and the ground. This capability will afford an opportunity to provide pilot-generated (keyboard entry) reports on significant weather into the data base. The FAA will be conducting experiments with the DABS digital link capability in the next several years at the National Aviation Facilities Experiment Center (NAFEC). The potential this system offers in both acquiring and disseminating data for cockpit display warrants close monitoring of the experimental work at NAFEC in the next few years.

Another important development is the Aircraft to Satellite Data Relay (ASDAR) - a communications system developed by NASA (Lewis Research Center) to provide PIREPS from commercial aircraft in near real-time, on a fully automated basis. The ASDAR system has been in operation for the past 12 months on a Pan American B-747 aircraft and the results have been encouraging. It is expected that 18 systems will be operational by December 1978.

In this connection, it is interesting to note that a program has been proposed to demonstrate the potential for improving aircraft fuel efficiency through the use of high resolution winds and temperatures at flight level. A data base consisting of approximately 100 aircraft will provide PIREPS every 800 seconds, 13 hours a day for a 12-month period starting December 1978. By providing comparisons between present airline flight plans and those based on this high resolution data, it may be possible to quantitatively demonstrate the advantage of this new data base. If an advantage can be shown (and a 1% improvement means tens of millions of dollars saved), then the ASDAR system could provide the required information on an operational basis.

Appendix A

Acronyms

ADP	Automatic Data Processing
AEDC	Arnold Engineering Development Center
AEHP	Atmospheric Electricity Hazards
AFGWC	Air Force Global Weather Center
AFOS	Automation of Field Operations and Services
AIM	Airmans Information Manual
AIRMET	Airman Meteorological Advisory
ALPA	Air Line Pilots Association
AMOSV	Automated Meteorological Observation Station-Mark V
ARTCC	Air Route Traffic Control Center
ASDAR	Aviation Satellite Data Relay
ASRS	Aviation Safety Reporting System
ATA	Air Transportation Association
ATC	Air Traffic Control
ATIS	Automatic Terminal Information Service
ATL	Advanced Technology Lab
AV-AWOS	Aviation-Automatic Weather Observation System
AWS	Air Weather Service
CAA	Civil Aviation Administration
CAT	Clear Air Turbulence
CRT	Cathode Ray Tube
CTOL	Conventional Take-Off and Landing Aircraft
CWSU	Center Weather Service Units

DABS Discrete Address Beacon System
DCPA Defense Civil Preparedness Agency
DFDR Digital Flight Data Recorder
DH Decision Height
DOD Department of Defense
DOT Department of Transportation
ECM Electronic Counter Measure
FAA Federal Aviation Administration
FAR Federal Aviation Regulation
FSS Flight Service Stations
GA General Aviation
GFWS Gust Front Warning System
HISS Helicopter Icing Spray System
IAD Dulles International Airport
ICAD International Civil Aeronautics Organization
IEMCAP Intrasytem Electromagnetic Compatibility Analysis Program
IFR Instrument Flight Rules
ILS Instrument Landing System
IMC Instrument Meteorological Conditions
INS Inertial Navigation System
IRU Integrating Rate Unit
JDOP Joint Doppler Operations Program
LAES Landing Aid Experiment Station
LLWAS Low-Level Wind Shear Alert System
LSI Large Scale Integrated Circuits
LWC Liquid Water Content

MDA	Minimum Descent Altitude
MOS	Model Output Statistics
MSFC	Marshall Space Flight Center
NAFEC	National Aviation Facility Experimental Center
NAS	National Airspace System
NASA	National Aeronautics and Space Administration
NAVAIDS	Navigational Aids
NAWAS	National Warning System
NBS	National Bureau of Standards
NCC	National Climatic Center
NDC	National Distribution Circuit
NEMP	Nuclear Electromagnetic Pulse
NHC	National Hurricane Center
NMC	National Meteorological Center
NOAA	National Oceanic and Atmospheric Administration
NSSFC	National Severe Storms Forecast Center
NSSL	National Severe Storms Laboratory
NTSB	National Transportation Safety Board
NWA	Northwest Orient Airlines
NWS	National Weather Service
OAST	Office of Aviation Safety Technology
PATWAS	Pilots Automatic Telephone Weather Answering Service
PIREP	Pilot Report
PJS	Pressure Jump System
PNL	Pacific Northwest Laboratory
PVD	Planned View Display

RAWARJ Radar Reporting and Warning Coordination
RVR Runway Visual Range
SDC State Distribution Circuit
SELS Severe Local Storms
SIGMET Significant Meteorological Advisories
SMCC Systems Monitoring and Coordination Center
SRI Stanford Research Center
SST Supersonic Transport
STOL Short Take-Off and Landing Aircraft
SVR Slant Visual Range
TAP Terminal Alert Procedures
TERPS Terminal Procedures Committee
TDL Techniques Development Laboratories
TWEB Transcribed Weather Broadcast
UTSI University of Tennessee Space Institute
VFR Visual Flight Rules
VMC Visual Meteorological Conditions
V/STOL Vertical and Short Take-Off and Landing Aircraft
WPL Wave Propagation Laboratory
WSFO Weather Service Forecast Office

APPENDIX B

Roster of Workshop Participants

- | | |
|--|---|
| <p>1. Richard I. Adams
U.S. Army
DAVDL-EU-SYA
Ft. Eustis, VA 23604
804-878-2306</p> | <p>8. Dennis W. Camp
NASA/Marshall Space Flight Center
ES82/Space Sciences Lab
Huntsville, AL 35810
205-453-2087 FTS 872-2087</p> |
| <p>2. Mikhail A. Alaka
National Weather Service
W424
Silver Spring, MD 20910
301-427-7772</p> | <p>9. Fernando Caracena
Dept. of Commerce
NOAA-ERL-APCL
Boulder, CO 80302
303-499-1000 x6269</p> |
| <p>3. M.P. Amason
Section Manager
Lightning Protection
Douglas Aircraft Co.
Long Beach, CA</p> | <p>10. Larry S. Christensen
FWG Associates
RR 3, Box 331
Tullahoma, TN 37388
615-455-1982</p> |
| <p>4. Bob Bell, AAT-360
FAA
800 Independence Ave. SW
Washington, D.C. 20591
202-426-8802</p> | <p>11. John W. Connolly
Special Assistant for Aviation Affairs
NOAA/Dept. of Commerce
Washington, D.C. 20230
202-426-3223</p> |
| <p>5. John A. Birken
DOD
NAVAIR, AIR52026B
Washington, D.C. 20361
202-692-3935</p> | <p>12. George E. Cooper
NASA/Ames Research Center
M/S 239-3
Moffett Field, CA 94035
408-867-3335</p> |
| <p>6. Edward F. Blick
School of Aerospace
University of Oklahoma
Norman, OK 73071
405-325-5011</p> | <p>13. Phillip B. Corn
Equipment/Advanced Development Lab
AFFDL/FEA
Wright-Patterson AFB, OH 45433
513-255-5066</p> |
| <p>7. Harry L. Burton, AAT-40
FAA
800 Independence Ave. SW
Washington, D.C. 20591
202-426-8126</p> | <p>14. Norman L. Crabill
MS247
NASA/Langley Research Center
Hampton, VA 23665
804-827-3274</p> |

15. Charles A. Douglas
Consultant/NBS
7315 Delfield St.
Chevy Chase, MD 20015
301-656-7875
16. L.J. Ehernberger
NASA/Dryden Flight Research Ctr.
Box 273
Edwards, CA 93423
805-258-3311 x340/447
17. Charles E. Elderkin
Battelle Pacific Northwest Labs
Box 999
Richland, WA 99352
509-946-2335
18. John H. Enders
NASA HQ
ROC-10
Washington, D.C. 20546
202-755-2377
19. Walter Frost
University of Tennessee
Space Institute
Tullahoma, TN 37388
615-455-0631 x217
20. Robert L. Gardner
Flight Safety Officer
AFISC/SEFB
Norton AFB, CA 92409
714-382-3416
21. Bruce L. Gary 354-3198
Jet Propulsion Lab
4800 Oak Grove Drive
Pasadena, CA 91103
213-354-3198 FTS 792-3198
22. Richard D. Gilson
Ohio State University
Box 3022
Columbus, OH 43210
614-422-8730
23. Nigel Gregory
British Defense Staff/UK DRDS
3100 Massachusetts Ave. NW
Washington, D.C. 20008
202-462-1340 x2569
24. Edward M. Cross
National Weather Service
8060 13th Street
Silver Spring, MD 20910
301-427-7726
25. John C. Houbolt
MS 116
NASA/Langley Research Ctr.
Hampton, VA 23665
804-229-5434
26. Arthur Hilsenrod
FAA/DOT
2100 Second St. SW
Washington, D.C. 22101
202-426-8427
27. Thomas P. Incrocci
HQS Air Weather Service, USAF
AWS/SNPA
Scott AFB, IL 62225
618-256-4741 FTS 255-4741
28. Garry C. Jackson
Meteorologist
AFFDL/WE
Wright-Patterson AFB, OH 45433
513-255-6626
29. Robert L. Klapprott
FAA
Rm. 220, Mid-Continent Airport
Wichita, KS 67709
316-942-4281
30. Ronald H. Kohl
University of Tennessee
Space Institute
Tullahoma, TN 37388
615-455-0631 x234

31. Richard L. Kurkowski
NASA/Ames Research Center
Flight Systems Research Div.
Moffett Field, CA 94035
415-965-6219
32. John A. Lasley, Jr.
Chief/Staff Meteorology
ASD/WE
Wright-Patterson AFB, OH 45433
513-255-2207
33. Jean T. Lee
National Severe Storms Lab
1313 Halley Circle
Norman, OK 73069
405-231-4916 FTS 736-4916
34. James Luers
University of Dayton
College Park Drive
Dayton, OH 45469
513-229-3921
35. Charles A. Lundquist
Dir., Space Science Lab
NASA/Marshall Space Flight Ctr.
Huntsville, AL 35812
205-453-3105
36. John McCarthy
University of Oklahoma
School of Meteorology
Norman, OK 73019
405-325-3242
37. A. Charley McTee
Bunker Ramo
Box 218
Randolph AFB, TX 78148
512-658-5493
38. William W. Melvin
Air Line Pilots Association
1101 W. Morton
Denison, TX 75020
214-463-1246
39. David J. Moorhouse
Chief/Flying Qualities
AFFDL/FGC
Wright-Patterson AFB, OH 45433
513-255-5676
40. Harold N. Murrow
NASA/Langley Research Center
M/S 243
Hampton, VA 23665
804-827-3451
41. Ernest A. Neil
Chief/Meteorology Program Office
NASA/Goddard Space Flight Center
Greenbelt, MD 20771
301-942-3038
42. Dennis W. Newton
Cessna Aircraft Co.
ARC Division, Box 150
Boonton, NJ 07005
201-347-5117
43. Loyd C. Parker
NASA/Wallops Flight Center
Wallops Island, VA 23337
804-824-3411 x640
FTS 928-5640
44. Frances C. Parmenter
National Environmental Satellite Ser.
World Weather Bldg., Room 601
Washington, D.C. 20233
301-763-8282 FTS 763-8282
45. Porter J. Perkins
NASA/Lewis Research Center
MS-77-2
Cleveland, OH 44135
216-433-4000 x6684
46. J. Anderson Plumer
Lightning Technologies, Inc.
560 Hubbard Avenue
Pittsfield, MA 01201
413-499-2135

47. Robert J. Roche
FAA
2100 Second St. SW
Washington, D.C. 22101
202-426-2804
48. John T. Rogers
Boeing Commercial Airplane Co.
Box 3707
Seattle, WA 98124
206-237-1453
49. Ernest E. Schlatter
FAA/NAFEC
ANA-410
Atlantic City, NJ 09405
609-641-8200 x2759
50. Rance W. Skidmore
HQ Air Weather Service
AWS/SNP
Scott AFB, IL 62225
618-256-4741 FTS 255-4741
51. Loren J. Spencer
FAA, ASF-30
800 Independence Ave. SW
Washington, D.C. 20591
202-426-2604
52. Charles H. Sprinkle
National Weather Service
8060 13th Street
Silver Spring, MD 20910
301-427-7726
53. Robert Steinberg
NASA
Lewis Research Center
Cleveland, OH 44135
216-433-4000 x6677
54. Joseph W. Stickle
Asst. Chief, Flight Service Div.
NASA/Langley Research Center
Hampton, VA 23665
804-827-2037
55. Arthur Varnado
FAA
800 Independence Ave. SW
Washington, D.C. 20591
804-827-2037
56. William W. Vaughan
NASA/Marshall Space Flight Ctr.
Code ES-81
Huntsville, AL 35812
205-453-3100
57. Robert T. Warner
AOPA
Box 5800
Washington, D.C. 20014
301-951-3923
58. Edwin A. Weaver
Optical Engineer
NASA/Marshall Space Flight Ctr.
Huntsville, AL 35812
205-453-1597
59. Guy G. Williamson
ARAP
Box 229
Princeton, NJ 09540
609-452-2950
60. Maurice A. Wright
University of Tennessee
Space Institute
Tullahoma, TN 37388
615-455-0631 x216
61. Andy D. Yates, Jr.
Air Line Pilots Association
7413 Park Terrace Drive
Alexandria, VA 22307
703-765-7423



**A
SUCCESSFUL
CONFERENCE**



**ORIGINAL PAGE IS
OF POOR QUALITY**

252