

GEOS Axial Booms

Gunter K. Schmidt, Dornier Systems GmbH, Friedrichshafen, Germany

ABSTRACT

A Booms and Mechanisms Subsystem was designed, developed, and qualified for the geostationary scientific satellite GEOS. The project was sponsored by the EUROPEAN SPACE AGENCY as part of the GEOS development contract. Part of this subsystem are four Axial Booms consisting of one pair of 1 m booms and one pair of 2,5 m booms.

Each of these booms is carrying one "bird cage" electric field sensor. Alignment accuracy requirements led to a telescopic type solution. Deployment is performed by pressurized nitrogen. The main components of this system are:

- Telescopic Section
- Release Mechanism
- Pressure System
- Triax Cable Harness
- Experiment Canister

At deployment in orbit two of these booms showed some anomalies and one of these two deployed only about 80 %. Following this malfunction a detailed failure investigation was performed resulting in a design modification of some critical components as release mechanism, guide sleeves of the telescopic elements, and pressure system.

INTRODUCTION

Four special telescopic booms were developed for the scientific satellite GEOS as part of the Booms and Mechanisms Subsystem.

GEOS is a spin stabilized satellite with a number of booms extending from the spacecraft body for positioning experiment probes. The experiments measure magnetic and electric fields in the low frequency spectrum.

One of the experiments requires two pairs of wire sphere sensors of 100 mm diameter to be extended 1 m and 2,5 m above the spacecraft body in approximately 70 cm distance parallel to the spin axis. The design requirements led to the development of telescopic booms that are deployed by a nitrogen gas pressure system.

GEOS was launched in April 77. After positioning the spacecraft in a final orbit, its booms were released and deployed. However, one of the "Long Axial Booms" deployed only about 80 to 90 %, resulting in a failure investigation.

This presentation delineates the design details of several critical components and the failure investigation following the partial function failure of the failed "Axial Boom".

FUNCTIONAL CHARACTERISTICS

The four Axial Booms deploy and support GEOS's four wire-sphere electric-field sensors. During launch the experiment spheres are stored at the base of the spacecraft in canister-like containers which are sealed by thin aluminium-foil membranes. The spheres are electrically connected by helically-wound triaxial cables routed within the telescopic booms. (see Fig. 1) Sufficient stiffness was achieved by using aluminium-alloy tubes with a large outer diameter, and thin walls to withstand the bending loads due to centrifugal forces induced by the maximum deployment spin rate of 30 rpm.

Torsional orientation is provided by a keyway. The axial booms are locked by a three-ball mechanism during launch (see Fig. 2) and are released and deployed by pressurised nitrogen, stored in pyrotechnically activated tank valve assemblies at 110 bar. Gas flow during deployment is controlled by orifices at the base of each boom, providing a deployment time of 1 to 4 sec. The gas system maintains a continuous flow for 15 to 20 sec to provide an adequate safety margin. Numerous deployment tests in vacuum were necessary to ultimately define the optimum parameters for this pressure system.

Because of the extreme magnetic and chemical cleanliness required for GEOS, a very careful selection of materials and processes was mandatory.

DESCRIPTION OF THE OBSERVED ANOMALIES

After positioning GEOS in its final orbit, its eight Booms and five Mechanisms were deployed. However, two Axial Booms showed some anomalies during deployment and one of these two, a Long Axial Boom, extended only about 80 to 90 % of its full length.

The table below provides an interpretation of deployment data of the Axial Booms as observed in orbit during April 30, 1977. The observations are based on telemetry data from the accelerometer output and the boom status switches. Several of the interpretations are conclusive, while others remain inclusive (Ref. 1).

Configuration Data:	Short Axial Booms		Long Axial Booms	
	+X/FS	-X/PM	+Y/FM	-Y/FM
Deployment length	1 m		2,5 m	
overall length	1,6 m		3,1 m	
tip alignment	± 0,02 m		± 0,02 m	
release delay:	(sec)	(sec)	(sec)	(sec)
t_r nominal	0,5 ± 0,05	0,5 ± 0,05	0,35 ± 0,05	0,25 ± 0,05
t_r observed	0,5	0,5 or 10,9	6,6	0,8 ± 0,6
deploy time:				
t_d nominal	1,5 ± 1	1,5 ± 1	2,7 ± 1,5	2,7 ± 1,5
t_d observed	0,9	10,8 or 0,6	0,8	0,55 ± 0,6
Deployment time:				
$t_D = t_r + t_d$				
t_D nominal	2 ± 1	2 ± 1	3 ± 2	3 ± 2
t_D observed	1,4	11,3		1,45 ± 0,6
HK - Signal	yes	no	yes	no
achieved deployment length	full	full or nearly full	80 to 90 %	full

The information gained from spacecraft data is not totally unambiguous. The -X PM/SAB data can be interpreted in two ways:

- a) Release occurred very late and was followed by a fast deployment.
- b) Release occurred for both Short Axial Booms (+X and -X axes) at the same time (ref. 1 Fig. 1a spike A1). This also occurs under normal conditions within a few milliseconds time frame.
For the +X SAB release was followed by a nominal deployment. However, deployment of the -X SAB may have momentarily halted after an initial start, due to stiction, and then continued some 11 sec later.

According to the HK-signal the release of the +Y Long Axial Boom occurred approximately 6 to 7 seconds too late. Following the delayed release, a deployment action of this boom was observed at the accelerometer output. However, any conclusions are subject to doubt, as the accelerometer went into saturation when the -Y LAB deployed and as the connection of HK-data and accelerometer readings were considered ambiguous for the Long Axial Boom. The actual deployed length achieved by the +Y Long Axial Boom was determined from attitude manoeuvre and shadow spike data from the LAB experiment sensors.

POSSIBLE EXPLANATIONS FOR THE ANOMALIES

1. Change in friction properties at seals, seal ring, and guide rings, due to:
 - 1.1 effects of hard vacuum
 - 1.2 effects of Van Allen radiation exposure
 - 1.3 temperature effects creating cold flow of the teflon guide rings
2. Reduction of gas flow, due to:
 - 2.1 filter contamination
 - 2.2 orifice choking
 - 2.3 piping leakage
3. Release Mechanism jamming, due to:
 - 3.1 ball-latch tolerances
 - 3.2 piston over travel
 - 3.3 increased friction between ball and ball cage
4. An incident due to launch failure
5. A zero-g Effect

Most of the above explanations are essentially irrelevant since they would have caused different deployment data. Only the effects of 1.3 (stiction), 2.2 (orifice choking), and 3.3 (delayed release) can be considered as valid explanations for the anomalies observed.

FAILURE INVESTIGATION AND SIMULATION TESTS

To gain additional information about the failure behaviour, an investigative test programme was commenced. This programme consisted of three test series.

- Single gas bottle tests
- Release mechanism failure simulation tests
- Orifice choke simulation tests

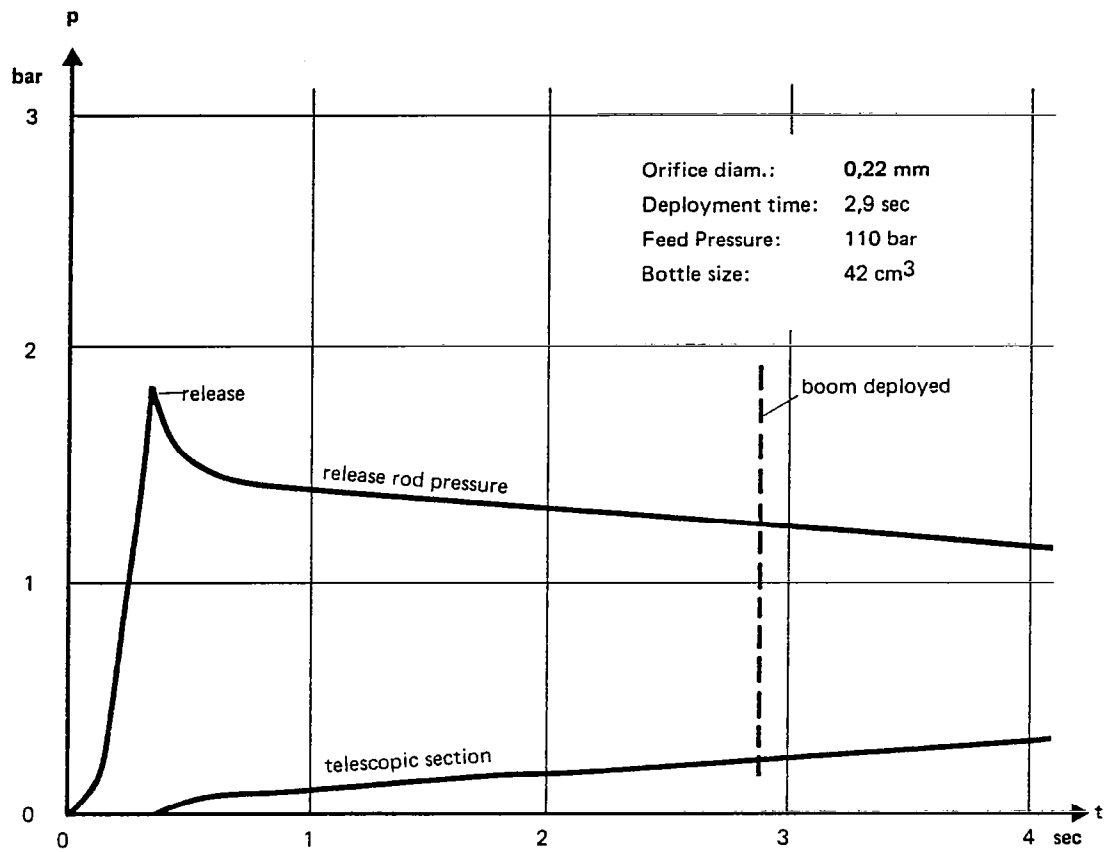
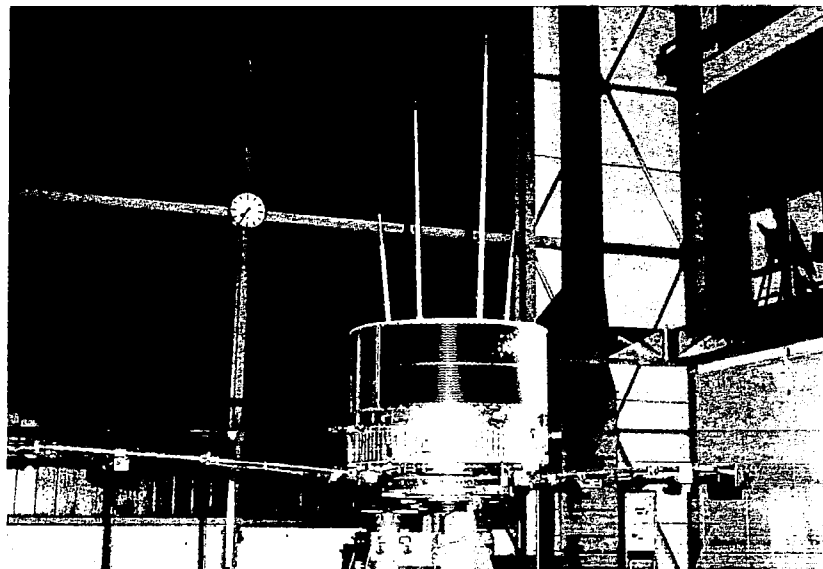

Fig. 3: Long Axial Boom - Pressure Profile



GEOS—Spin Deployment Test of Short Radial and Axial Booms

Approximately one hundred vacuum deployments have been performed in the course of this investigative programme.

1. Tests with a Single Gas Bottle for each pair of the Axial Booms with increased charge pressure. For GEOS-2 it is proposed to keep a second gas bottle for each boom pair in reserve. For this reason, the single bottle pressure had to be determined duplicating deployment times of the GEOS-1 two bottle arrangement charged with 110 bar pressure. The tests demonstrated that the deployment times with a single bottle with pressures of 150 to 160 bar are nearly identical to the required deployment time for two bottles with 110 to 115 bar pressure.
2. In a second test series, a jamming of the release balls in the release cage was simulated. The test setup allowed the release piston to move, but the release of the boom was delayed by a restraining wire which was melted following the required delay times.
3. In the third test series, an orifice choke was simulated by a thin wire inlay in the orifice channel. During these tests the axial booms were equipped with a special release block which allowed recording of the pressure profiles in the release rod and the telescopic section. A typical pressure profile is shown in Fig. 3.

RESULTS AND EVALUATION

As a result of the above investigations, the release delay t_r and the deploy-time t_d are determined to be the critical parameters. These parameters indicate a characteristic dependency for each of the possible failure explanations. The diagram Fig. 6 illustrates these characteristics.

Curve I shows the relationship attributable to increased friction (1.3). The release delay is not influenced by increased friction in the seal and guide system. Therefore, this failure develops as a vertical line. (see Fig. 6).

Curve II shows the relationship of t_r and t_d for the condition of a reduced gas flow. The reduced gas flow influences the deploy time significantly. Its influence on the release delay is less distinct.

Curve III shows the t_r , t_d dependency for the condition of release mechanism jamming. This failure mode causes the pressure to increase in the release rod and the stowed telescopic sections. When release occurs, there is an increase in deployment speed. This behaviour is more pronounced for the SAB than for the LAB, due to the lower deployed to stowed volume ratio of the SAB.

The full deployment capability is limited by the amount of gas available.

If we apply the orbit data to this diagram, the following can be derived:

The SAB data substantiate a position on either curve I or curve III (point b and a), depending on individual interpretation of the orbit data.

There is no substantive evidence from the orbit data that orifice contamination has to be considered. The diagram demonstrates that any partial orifice choking would cause only a small release delay followed by a slow deployment of the SAB. The orbit data does not support this interpretation.

If the delayed release of the Long Axial Boom has to be considered as definite, any friction has to be excluded, since the +Y LAB still deployed about 80 % following the delayed release. Orifice choking can also be excluded as it was impossible, during the tests, to generate release delays of greater than 4 seconds. The release pressure level could not be achieved for the delayed boom at higher choke rates. This condition is valid also during orbit.

Therefore, a malfunction in the release mechanism can be assumed only for the Long Axial Boom. During the first few seconds of deployment, motion following this delayed release was relatively

Fig. 6 Axial Booms – Deployment Characteristics

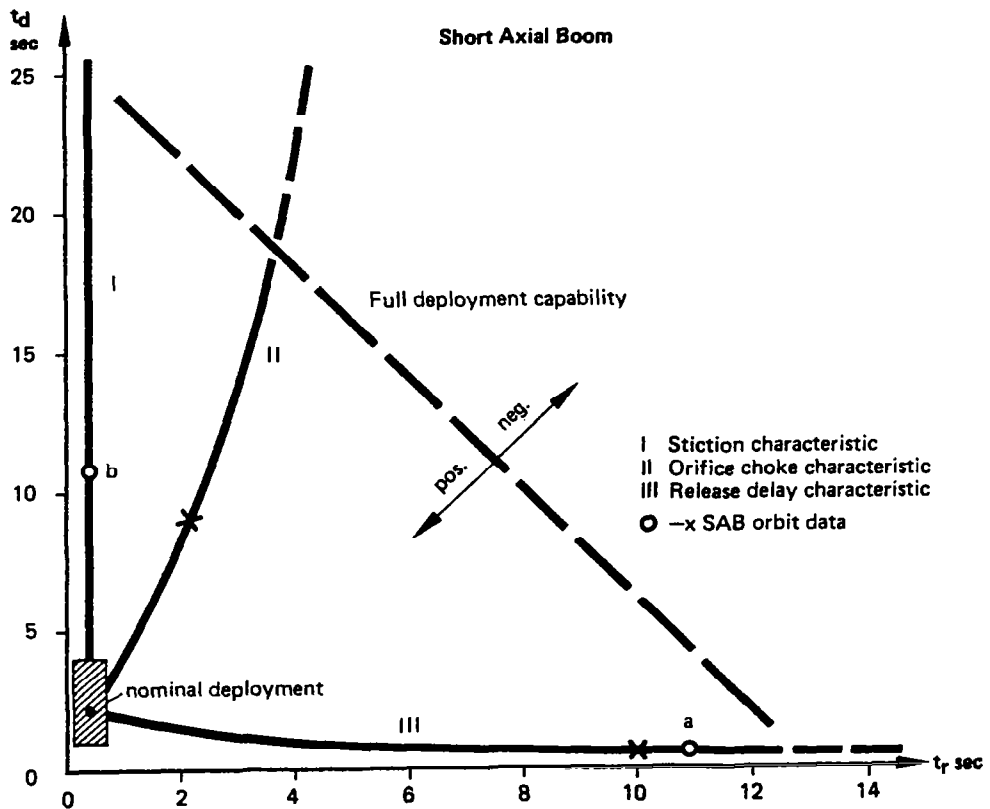
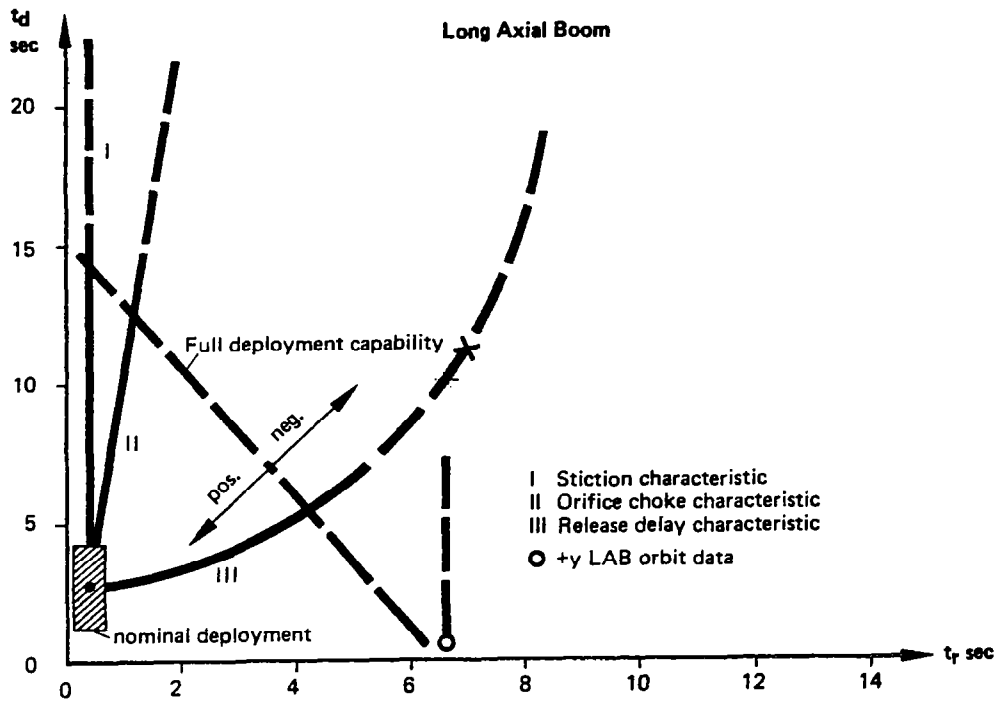

rapid. However, as the accelerometer was in saturation it was not indicated in telemetry data. Following the initial rapid deployment, motion rate was reduced significantly for approximately five seconds and finally came to a stop at about 80 % deployment length.

WHAT MAY HAVE CAUSED THE MALFUNCTION?

Increased deployment times due to stiction (1.3) were observed some few times during temperature tests. At higher temperatures the teflon guide rings show a cold flow tendency, which can result in a friction increase. However, this friction increase was found within acceptable limits at temperatures below 50°C.

Release Mechanism jamming:

The friction conditions between ball and ball cage had been carefully calculated for GEOS-1. These calculations demonstrated a sufficient safety margin to jamming of 1,5 to 2. However, an indentation caused by the sharp edge of the titanium bushing (Fig. 7 part 1) could have resulted in increased friction, leading to a failure kinematic as indicated in Fig. 7a, b and c.

Inspection of GEOS-1 spare unit release balls proved that the indentations exist. Repeated stowage and release increased the number of indentations and the likelihood of two indentation positions is highly probable; refer to Fig. 7c.

The proper functioning of the +X FS/SAB, Flight Spare Short Axial Boom lends support to this theory, since this boom had not been exposed to repeated testing.

Following actuation of the pyro valves for boom deployment, all four release pistons moved forward and 10 balls moved freely, except for one ball at the +Y LAB and most likely a second ball at the -X SAB may have stuck as shown in Fig. 7c. The gas expanded through the outlet hole into the telescopic sections and decayed as shown by the pressure profile. After some seconds the pressure in the telescopic section nearly equalized to the release rod pressure. At this time, the release spring, which was still compressed may have started to move the release piston in reversed direction due to the reduced pressure differential (see Fig. 2b). It is very likely that due to this piston motion the stuck ball in the jammed mechanism released and movement continued.

DESIGN IMPROVEMENTS

1. To reduce the possibility of friction due to cold flow of guide rings, the tightening torque for the fixation screws has been reduced to decrease the local stress concentrations at the guide ring. In addition, the teflon guide sleeve for RE1 was slightly modified to prevent possible jamming forces caused by cold flow resulting in configuration instability.
2. In GEOS-1 orifice and filter were screwed separately into the release block. During integration of the filter, loose particles may have been created by the screwing operation and trapped between filter and orifice. (Fig. 8a).
During failure investigation this condition was observed at one time.
For GEOS-2 a filter-orifice-assembly was developed which is assembled separately during increased cleanliness conditions with careful control under the microscope. This new design reduces significantly the possibility of particle creation and trapping (Fig. 8b).
3. The release mechanism modification mainly concerned the ball release piston and ball cage area. (Fig. 9).
 - The hard edge of the titanium sleeve was replaced by a soft aluminium chamfer to prevent indentation of the balls.
 - The ball cage holes which were cylindrical in GEOS-1 are now conical to improve the ball release. This modification significantly increases the friction safety margin for ball jamming from $\mu_1 = 0,41$ to $\mu_2 = 0,77$.

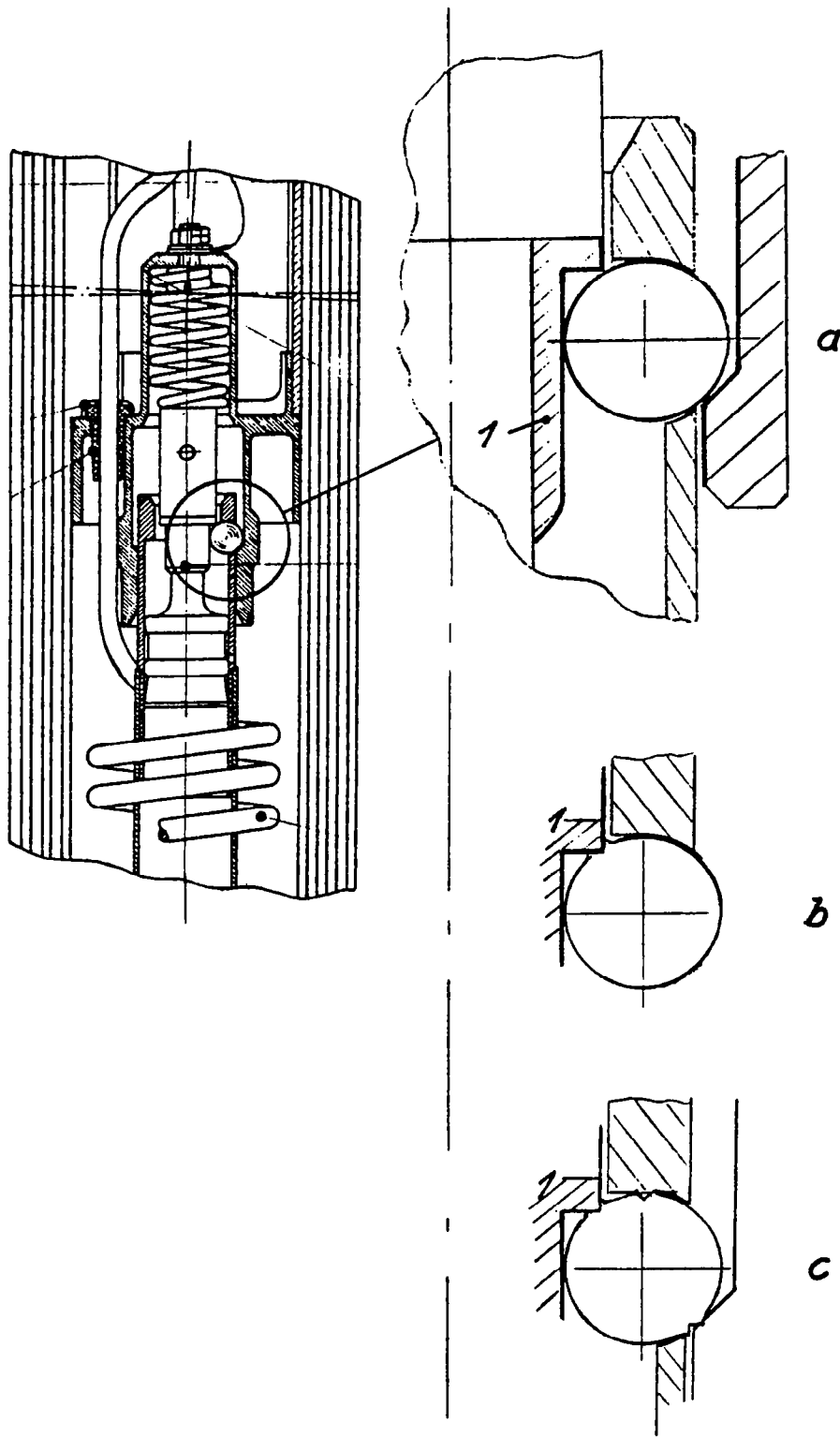

Fig. 7 Release Mechanism — Possible Failure Kinematic

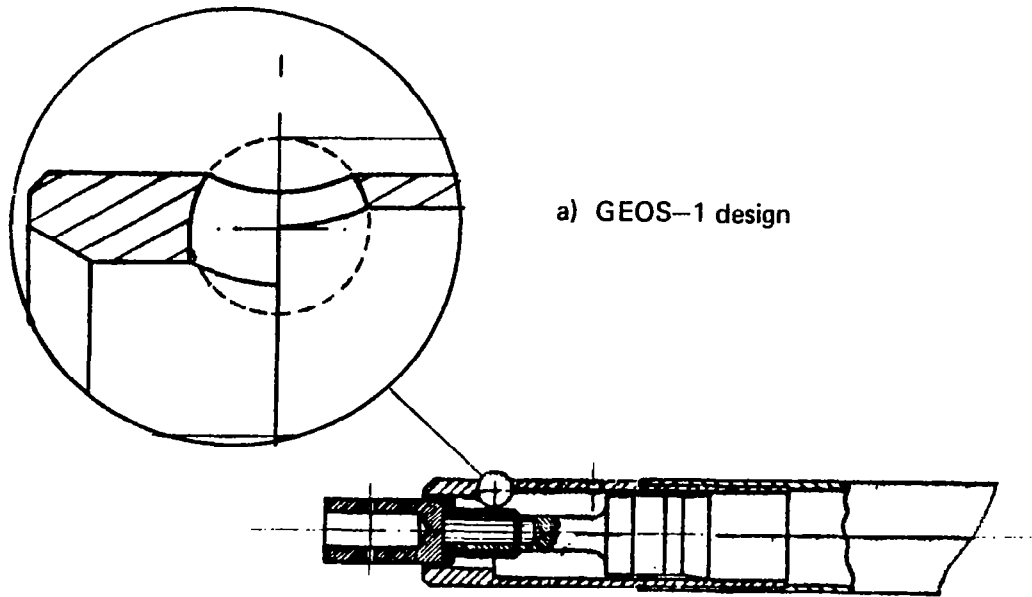
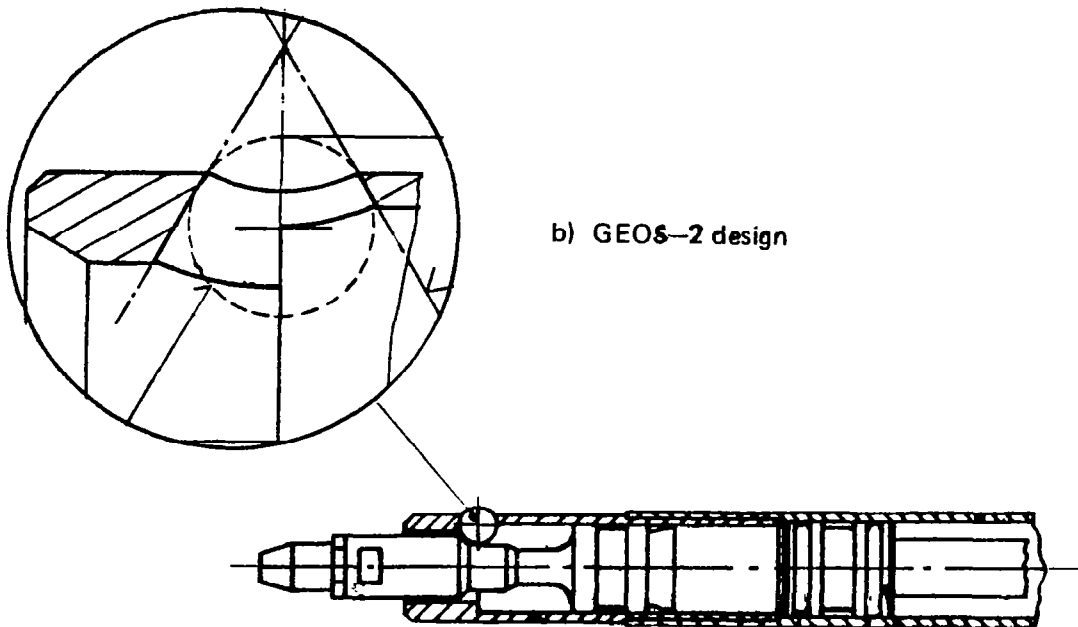

Fig. 9 **AXIAL BOOMS – Release Mechanism**



CONCLUSION

Considering the GEOS-1 housekeeping data and accelerometer data and the failure investigation results, the following can be derived:

- there is no indication that an orifice contamination caused the observed anomalies
- the data indicate that the reduced deployment length of the +Y LAB was caused by a malfunction of the release mechanism
- the anomaly in the SAB deployment behaviour was caused either by increased friction of one tube element or also by malfunction of the release mechanism.

REFERENCE

- 1) ESTEC-DOC. No. PG/01.2/CCK/14.728/JR "GEOS Axial Boom Deployment Sequence - Observations in Orbit" by C.C. Kalweit
- 2) Dornier - Study Note DO 5C SN 110 "Failure Investigation of FM Axial Boom Damages" by G. Schmidt
- 3) PM/FM/FS Axial Booms Log Books
- 4) BAC - "GEOS Axial Booms Improvement Ideas" by P.M. Grosse
- 5) Dornier - "GEOS Booms and Mechanisms Subsystem Manual" Vol. II Section 3.1.3 Axial Booms - Design and Analysis
- 6) BAC - Doc. No. GBA 1611 "Axial Booms Deployment Simulation Results" by E. Crellin
- 7) AERE Harwell-ESTEC Contract No. 2082/73 SK "The effects of radiation on the mechanical and electrical properties of the GEOS Satellite Long Boom Cable materials" by D. Verdin and P.R. Goggin
- 8) ESTEC-Memorandum ref. PG/01.2/BH/14542/HN "GEOS Axial Booms" by B. Henson
- 9) ESTEC-Memorandum ref.: PG/146.3/CCK/15.311/JR "GEOS Axial Boom Review Documentation" by C. Kalweit
- 10) ESTEC-Memorandum ref.: PG/510/BH/15.276/JR "GEOS-2 Axial Booms - Summary of Tests on Flight Model Booms" by B. Henson