

SCANNING AND FOCUSING MECHANISMS OF METEOSAT RADIOMETER

By J. JOUAN Société MATRA (France)

1. ABSTRACT

Two mechanisms, both of screw-jack type are described. The scanning mechanism, an oil lubricated and sealed unit drives and accurately positions the telescope of the METEOSAT radiometer. The dry lubricated focusing mechanism is used to adjust the focus of this telescope.

These two mechanisms have been designed developed and tested within the METEOSAT Radiometer programme under a contract from the «Centre National d'Études Spatiales» followed at the beginning of 1973 by a contract from the European Space Agency.

The METEOSAT programme is nearly completed now and the first flight model will be launch at the end of this year.

2. INTRODUCTION

The scanning and focusing mechanisms are settled onboard the METEOSAT Radiometer, a large Camera which will take line by line pictures of the earth from a geostationary satellite in the same manner as a TV picture using both the spin of the spacecraft and the tilt of a telescope. An overall view of the radiometer is given on Fig. 1.

The scanning mechanism provides the ± 9° degrees tilt angle of the telescope through 2 500 elementary steps of 1.256 10⁻⁴ radian. Twenty five minutes are needed to perform the 2 500 steps corresponding to one image and the mechanism is able to drive back the telescope ten time faster.

As the radiometer image quality is closely dependent on the characteristics of the scanning law, the mechanism is required to fulfil functional performances specifications particularly severe in terms of linearity of the scan curve, accuracy of each steps as well as repeatability of the short-term scanning. Moreover, the mechanism is required to work during three years in deep space environment conditions, which represents about 50 000 cycles.

The focusing mechanism allows ± 12 millimeters shift of the telescope focus by step increments of 0.140 mm. The focus adjustment is achieved by moving a dihedral reflector according to a pure straight-line motion.

In the following the main requirements of each mechanism are summarized and their design and performances are described in detail. Finally the main problems encountered during development and the way they have been solved are reviewed.

3. SCANNING MECHANISM

3.1 - Summary of the requirements

The main requirements derived from the radiometer system requirements are summarized in the following table. The scanning law requirement is related to the tilt angle of the moving telescope considered as a rigid body.

PARAMETER	NOMINAL VALUE	ACCURACY
● Functional performances		
* Scanning law requirements		
– number of steps	2 700	
– step increment	$4 \pi 10^{-5}$ rd	10 %
– 50 steps increment	$2 \pi 10^{-3}$ rd	$2 \cdot 10^{-4}$ rd
– slope of the global law	$\frac{0,054 \pi}{1\ 350}$	1 %
– repeatability of positioning at constant temperature		$2.5 \cdot 10^{-6}$ rd
* Step period	0.6 s	
* Rise time of each step	0.180 s	10 %
* Number of cycles over 3 years	50.000	
● Physical parameters		
* Mass	< 5 Kg	
* Electrical consumption		
– peak	8 W	
– average	3 W	

Since the beginning of the development, the high degree of criticality of the scanning drive mechanism has been recognized, and the baseline has been selected primarily in such a way as to achieve the highest possible reliability. For that reason, well proved state-of-the art solutions have been preferred to more sophisticated ones which could have presented higher development risks and associated costs. Moreover the presence of optical components and cooled detectors have led to avoid any risk of contamination and by the way to seal the mechanism.

Therefore the main features of the selected baseline are :

- Screw-jack unit driven by a stepper motor.
- Conventional oil lubrication of the sealed unit.
- Antibacklash links between moving parts.
- Telescope bearings made of flexural pivots.

After comparative study, the screw-jack device has been preferred to the servo-loop direct drive with optical encoder. The screw-jack offers excellent performances which may be achieved with existing technologies and standard components. Its basic advantage is that a high reduction ratio is obtained with moderate size and weight : as a result, a high torque margin is available, and the accuracy mainly depends on the last stage, i.e. the screw nut assembly itself ; because of the irreversibility, the telescope position remains fixed when the motor is not supplied with electric power ; a screw jack unit combined with a stepper motor is easily controlled in an open loop manner without the need of a position pickoff.

The drive electronics is thus simplified, and consist mainly of a set of power amplifiers feeding the motor windings, and digital circuits generating the logic sequence. Furthermore, the line identification system being not in the control loop is not essential for the operation of the drive mechanism, which improves significantly the overall reliability.

3.2 - Detailed description (Ref. Fig. 2)

Screw-jack unit (Ref. Fig. 3)

The screw jack comprises a stepper motor, a gear box, the lead screw/nut assembly and a potentiometer. All these components are enclosed in a hermetically sealed housing. A set of two metallic bellows provides for relative translation motion of the screw.

The stepper motor, a 200 steps per revolution SLOSYN HS 25 device drives the nut through a gear box having a reduction factor of 3.

The nut is mounted on two pairs of pre-loaded ABEC 7 MPB ball bearings. The rotation of the nut causes the screw to move in translation, as the leading frame prevents the screw from rotating. A potentiometer with two triangular plastic film paths is driven by the motor through the same reduction ratio of 3. The whole unit is splash lubricated, which avoids the difficult problem of dry lubrication in hard vacuum conditions. The screw-jack design has some noticeable advantages : the stepper motor has accurate and steady position at rest ; torque margining of 14 insures that no step can be missed except in the case of a command failure. The scanning accuracy is further improved by the control logic/motor design, as each telescope angular increment corresponds to 12 elementary steps at the motor. Actually, due to the high overall reduction ratio, only the screw/nut assembly is critical as far as the scanning accuracy is concerned. High performances may readily be achieved by a careful machining and running of the screw. Gears are antibacklash type ; materials are selected to minimize the effects of a temperature variation.

Leading frame and capstan device (Ref. Fig. 4)

The screw is fastened to a rectangular frame at its two tips. The linear motion of the frame is transformed into telescope rotation by the use of flexible metallic blades. One end of each blade is clamped to a curved sector fixed to the telescope, the other end being fastened to a small bar which is tightly connected to the frame by a set of prismatic shapes when being on orbit. A tensioning spring applies a constant load to the blades, in order to prevent from any backlash.

During launch phase, the telescope bearing latching device performs two functions which prevent the screw and the flexible blades from being overloaded by differential vibration motions.

- When the telescope is pulled down, the bars supporting the blades are disconnected from the leading frame so that not any effort can be transmitted through the blades.
- The leading frame itself is pushed again the main structure by the mean of calibrated springs fixed on the sectors.

When releasing the telescope, the bars, pushed up by a set of springs connect again with the leading frame. In the same time, the leading frame being free of any load comes back to its nominal scanning position.

3.3 - Modes of operation

Normal mode

Once per spacecraft revolution, i.e. every 600 ms, the motor drive electronics, stimulated by a signal, generates a sequence of logic signals which supply by groups of two the windings of the motor. 12 steps corresponding to a rotation of $21^{\circ}6$ are then performed during a time lapse of 180 ms. Taking account of the reduction ratios, the nut and the potentiometer turn through $7^{\circ}2$ in the same time and the screw moves of 35μ . The distance between the screw axis and the telescope axis of rotation being 278.5 mm, the corresponding angular increment of the telescope is 1.2566×10^{-4} rd.

The analog signal supplied by the potentiometer is digitalized and transmitted by telemetry. The lower bit corresponds to 4 motor steps, i.e. $1/3$ rd telescope step.

A low voltage (2.5V) ensuring a locking of the motor on the step is applied to the windings during the following 432 ms time interval during which the scanning of a line on the earth is situated.

Retrace mode

The sequence of operations is similar when the telescope moves back. However, a reduction of the rise time for each step (45 ms) and the higher rate of input timing signals allow to perform the 2700 steps 10 times faster i.e. in about 2.5 minutes.

An accurate reference position of the telescope is obtained by multiplexing the signal supplied by end of frame switches to the line identification signal coming from the potentiometer.

3.4 - Performances

The scanning laws are measured by using a laser interferometer the resolution of which is 0.1 second of arc. The measurements are handled through a Hewlett Packard computer.

The linearity requirement is readily met and the step accuracy is well within the specification : the 2700 increments measured on flight models is constant within 3 % (10 % specified) (see Fig. 5).

Step repeatability has been checked and the maximum deviation measured does not exceed $1.5 \cdot 10^{-6}$ rd.

Life tests up to 300.000 cycles representing nearly 20 years life have been performed without any degradation of the scanning law.

3.5 - Main problems encountered

— On the first breadboard built at the beginning of the contract, a modulation of the scanning law at the period of the screw turn has been identified so that the accuracy requirement was not met. This modulation was induced by a pitch movement of the leading frame around an axis passing through the screw at the center of the nut. This movement was amplified by the arm level between the screw axis and the capstan sectors. A minor modification of the leading frame allowing the screw axis to lie in the plane containing the blades and tangential to the sectors results in completely avoiding such a perturbation.

— Achievement of a perfectly sealed housing (leak rate below $2 \cdot 10^{-9}$ cm³ at m/sec of helium) has been the most worrying problem and has led to a large amount of development tests.

- sealing of materials of the same nature, stainless steel waves of bellows, aluminium caps of the housing has been obtain by electronic beam welding.

- sealed assembly of parts of different nature i.e. stainless steel element on aluminium element has been obtain by using the so-called "incrustation" technic developped for nuclear application.

This consist to sink a shaped stainless steel block in the aluminium block heated at a correct temperature before machining the whole assembly.

These welding technics have been developped and applied by the «Centre d'Études Nucléaires de Grenoble».

- The final sealing of the housing after filling of the mechanism with oil is obtained by pinching and cold welding of the aluminium filling pipe.

4. FOCUSING MECHANISM

The focusing mechanism is mainly characterized first by the high stability of the dihedral reflector required along the focusing range : less than 1 arc minute deviation all along the 12 mm motion amplitude and secondly by the choice of a dry lubrication technic of the unit using new technologies.

The mechanism consist of a size 11 stepper motor connected to a screw through a 5 : 1 gear. This screw drives a nut which supports the reflector and which is prevented from rotating by using a copper bellow. (Ref. Fig. 6)

The stability requirement has been met by the use of two accurately machined journal bearings which guide the nut.

The following technologies have been chosen for lubrication :

- Sliding surfaces i.e. journal bearings and screw-nut device are coated with bonded molybdenum disulphide film.

- Ball bearings, supplied by RMB (Switzerland) are ABEC 7 bearings the rings of which are coated with titanium carbide, a new technology already discuss in an other paper (ref. to «wear-resistant ball bearings for space applications» by M. BOVING, LSRH).

- The gear train is composed of one pinion made of DELRIN AF coupled to stainless steel pinions.

Main problems have been raised from the stability requirement which has led to tightly tolerance the journal bearings and a careful choice of the material regarding thermal effect.

Extensive life tests in ultra-high vacuum both on bearings and on a complete model have shown the ability of the chosen technologies to perfectly work in deep space environment. The evolution of the global resistive torque measured during life-test is shown on Fig. 7.

5. CONCLUSION

The two screw-jack mechanisms described above successfully meet their requirements through the application of completely different technologies. The scanning mechanism, characterized by its very high positioning accuracy has led to successfully solve the difficult problem of complete sealing. On the other hand promising dry lubrication technics have been qualified within the development of the focusing mechanism.

Acknowledgement

The author acknowledges the contributions and assistance of G. Bondivenne from ESA Meteorological Project Office and E. Cõnde and M. Boeto from Centre National D'Études Spatiales.

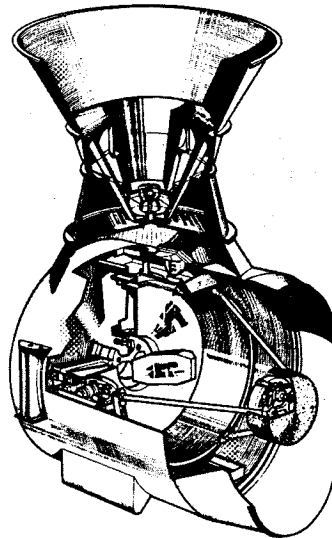

Overall view of METEOSAT Radiometer

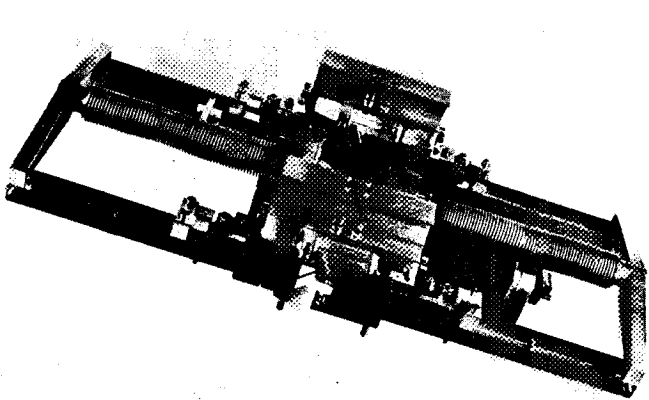

Scanning Mechanism

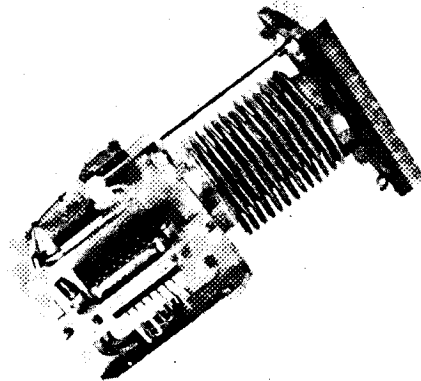

Focusing Mechanism

Fig. 1 – METEOSAT Radiometer

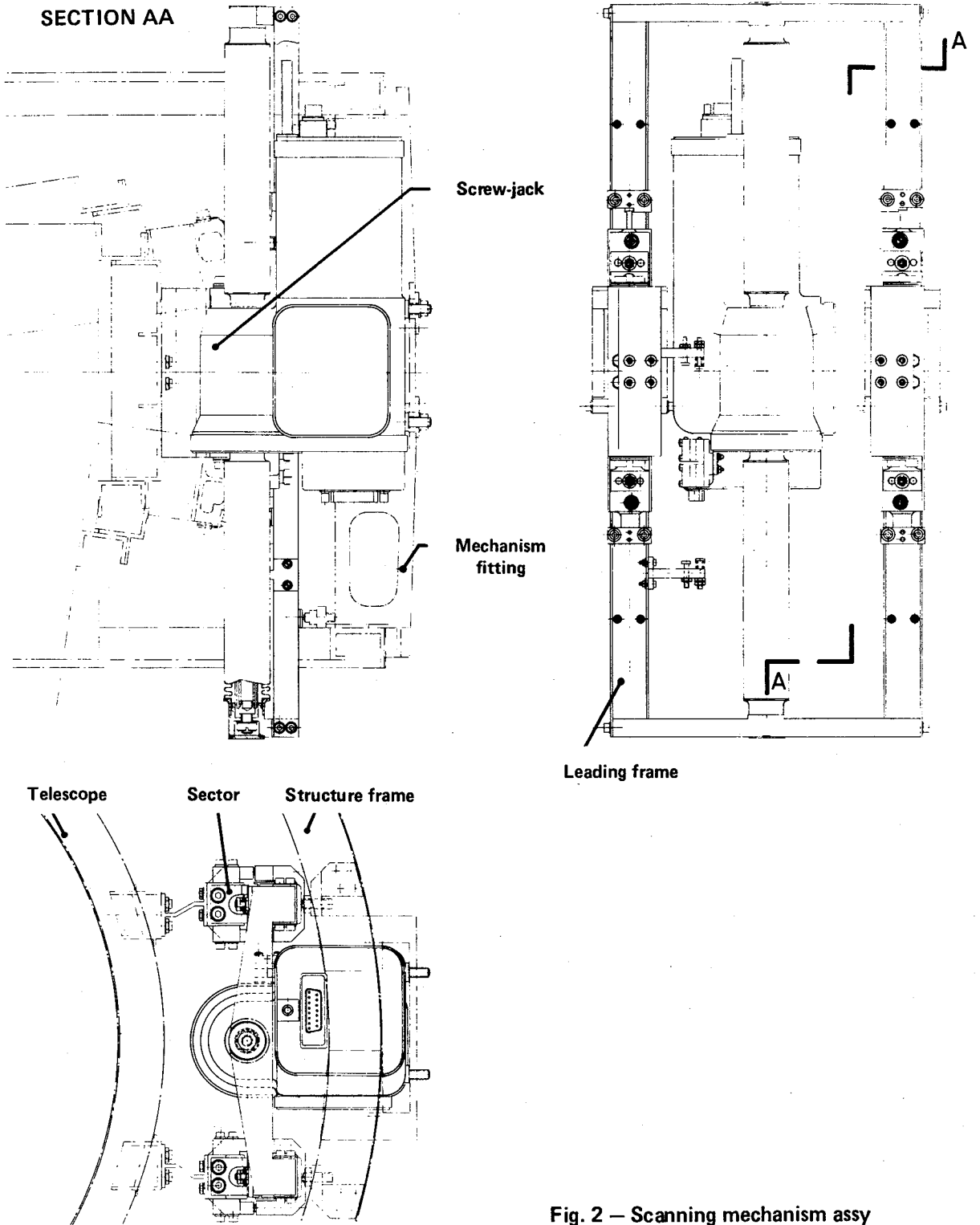

Fig. 2 – Scanning mechanism assy

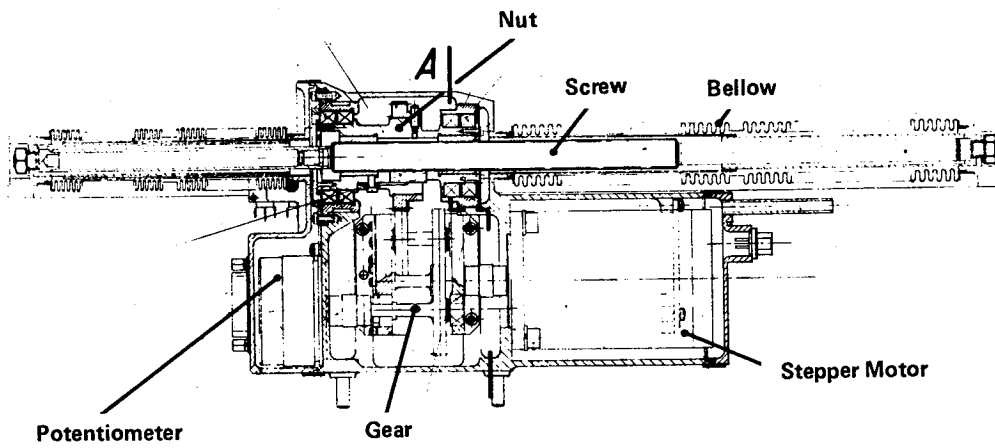

Fig. 3 – Screw-Jack unit

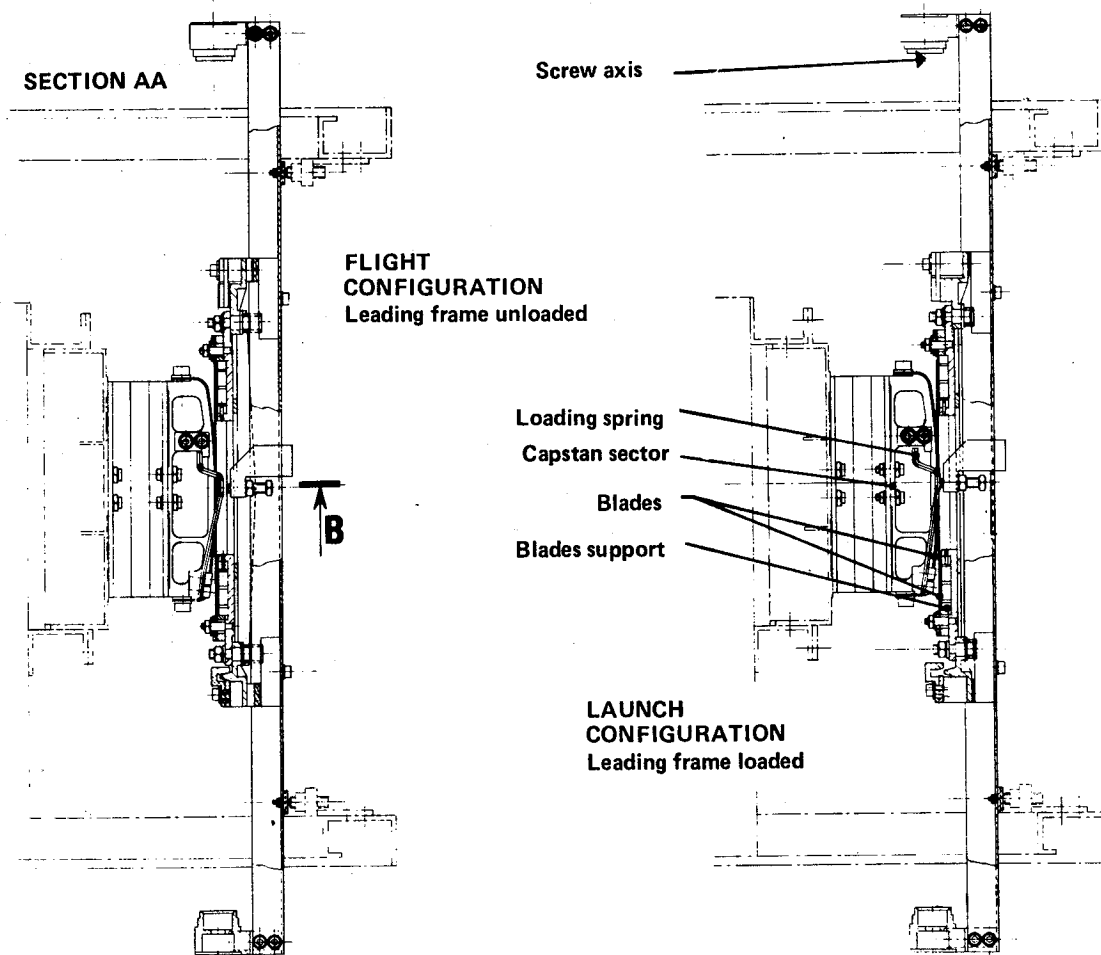

Fig. 4 – Leading frame assy

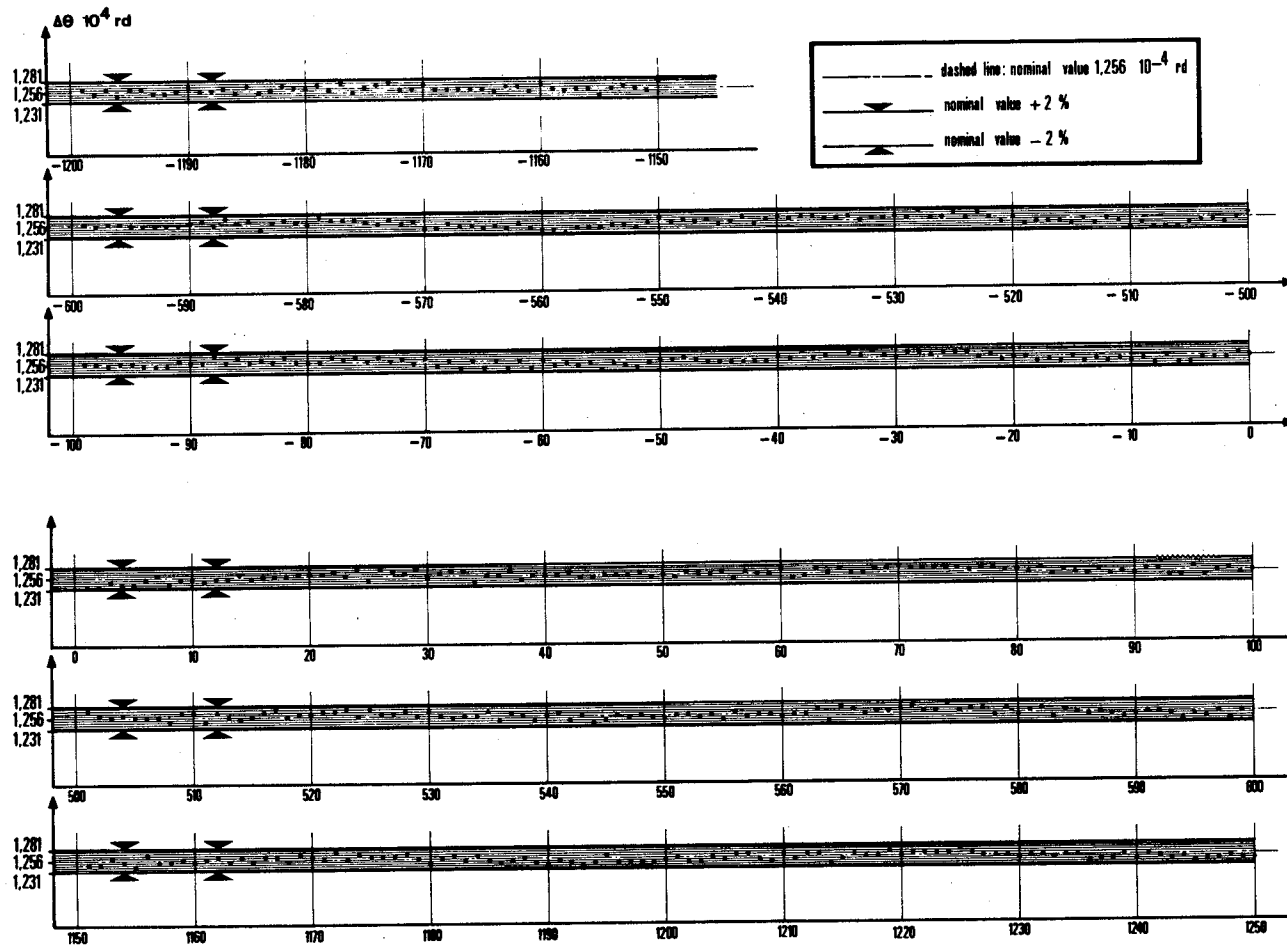

Fig. 5 – Step increments versus step number measured with a laser interferometer test equipment (accuracy : 0.1 arc sec i.e. $5 \cdot 10^{-4}$ mrd)

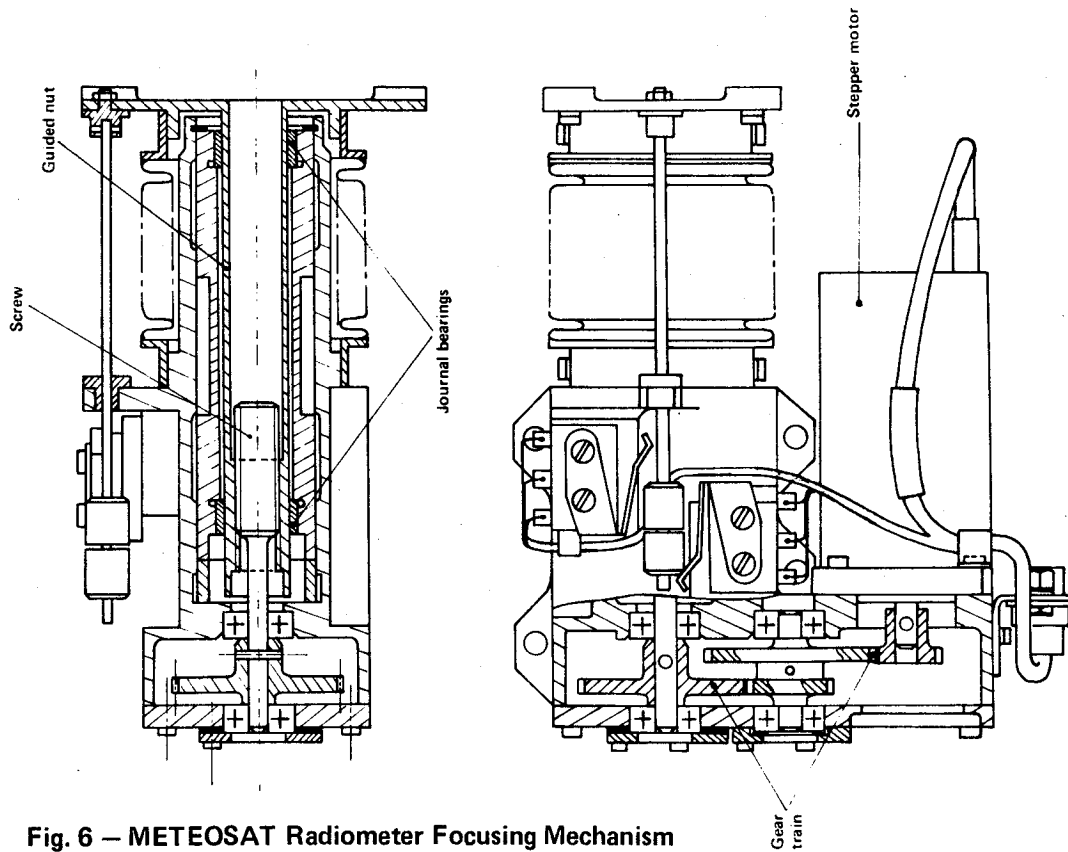

Fig. 6 – METEOSAT Radiometer Focusing Mechanism

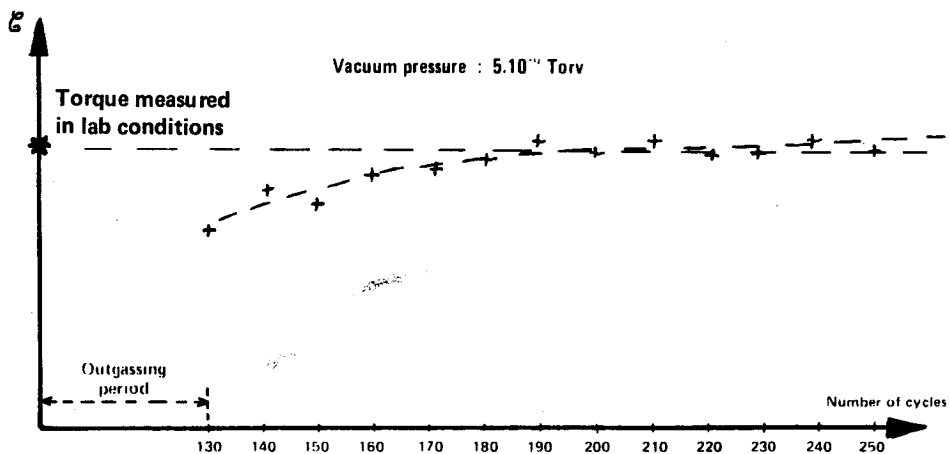

Fig. 7 Evolution of the resistive torque measured at the motor output during life tests in ultra-high vacuum