

FLY-AWAY RESTRAINT PIN MECHANISM
FOR THE ARMY'S PATRIOT MISSILE SYSTEM

By Frederick W. Knight

ABSTRACT

The development of the longitudinal restraint mechanism for the Army's PATRIOT missile system is reviewed. The initial design was an ordnance pin puller with a shear plane. Because of reliability problems and a desire to reduce cost, a "fly-away" restraint mechanism was chosen. After being manually unlocked, the restraint pin disengages the missile during launch by missile motion.

INTRODUCTION

The PATRIOT missile system concept incorporates a combination shipping-launching canister for maximum missile protection. The canister is designed to withstand and protect the missile from a wide range of handling and transportation loads. The launch rail and side shoes support the missile vertically and laterally. The missile is held longitudinally inside the canister by a steel pin inserted into the missile just forward of the motor section. The maximum transportation load on this pin is approximately 34,000 pounds longitudinally.

The basic criterion for the restraint pin is holding the missile in place under all pre-launch conditions while not preventing missile exit from the canister at launch. A simple pin puller concept (one that completely pulls the pin out before launch) is inadequate because some degree of continuous restraint is always needed to prevent the missile from sliding backward at its 38 degree launch angle or under shock loads resulting from battlefield conditions. The restraint pin mechanism must be capable of returning to its transportation mode if a decision is made not to launch or in case of missile malfunction. There is also a requirement that the restraint pin not electrically ground the missile to the canister.

This paper discusses two approaches for restraint pin design: 1) an initial ordnance mechanism and 2) a passive fly-away mechanism.

SYMBOLS

- A Horizontal pivot length
- B Vertical pivot length
- C Depth of penetration of pin
- D Pin diameter
- E Horizontal distance for pin to clear socket

- F Socket diameter
- R Hypotenuse of A and B
- X Gap between pin and socket diameters for line to line contact
- θ Pivot angle prior to launch
- ϕ Pivot angle just as forward edge of pin clears the socket
- α Pin rotation to clear socket ($\phi - \theta$)

ORDNANCE-DRIVEN RESTRAINT PIN DESIGN

Initially, an ordnance-driven restraint pin concept was selected for engineering development. This pin was located on the top portion of the canister, just forward of the motor section of the missile. The design consisted of an integral piston/pin arrangement that was driven upward by expanding gases released by an explosive power cartridge (Figure 1). Pin overtravel was attenuated by a return spring and crushable stop. The pin was retained in the retracted position by a spring-driven locking pin.

The pin did not completely come out of the missile, but far enough to expose a shear plane built into the pin. At launch, the missile thrust sheared the bottom portion of the pin and this portion was retained by the missile. This system was automatically activated a fraction of a second prior to launch as part of the launch sequence. In the event of missile malfunction, the locking pin holding the pin was manually retracted allowing the pin to return to its transportation position for safe missile handling. The electrical isolation requirement was accomplished at the interface of the housing and canister skin by hard coated aluminum shims, bushings, and washers.

Although this mechanism was successfully developed to meet system requirements, it had several undesirable features:

- 1 The locking pin had a tendency to hang up, thereby reducing system reliability.
- 2 A high degree of machining and close tolerances resulted in steep manufacturing costs.
- 3 The system required use of an ordnance device with its associated cost and reliability aspects.

FLY-AWAY RESTRAINT PIN DESIGN

The initial restraint pin mechanism was redesigned as part of a cost reduction effort in the PATRIOT engineering development program. Subsequent tradeoff studies comparing various design concepts selected the fly-away restraint pin design because of its simplicity, reliability, and cost. For convenience, the mechanism was relocated from the top to the bottom of the canister, while its longitudinal position remained the same.

A major feature of the new design is the elimination of an explosive device. The restraint pin is hinged to the housing aft of the centerline of the pin (Figure 2). The pin is restrained aft and laterally by a fixed housing and the forward direction is restrained for handling and transportation purposes by a movable steel bar. After the canister is elevated and prior to launch, the bar is manually moved out of the way through a mechanical linkage. When the missile moves forward after ignition, the pin rotates and drops out of the missile socket. In the event of a decision not to launch, the bar can be easily moved back to the locked position. The electrical isolation requirement was accomplished at the interface of housing and support channels (Figures 3 and 4) by hard coated aluminum bushings, and fiberglass shims and washers.

PIN TO SOCKET CLEARANCE ANALYSIS

Restraint pin to missile socket clearance is a critical part of this design. The movement of the pin to missile is a combination of rotational and translational motion. As the pin rotates out of the missile, sufficient clearance must be allowed between pin and socket to prevent binding and possible missile damage. The minimum clearance required is a function of pivot location, pin diameter, and depth of penetration. This relationship is derived in the following analysis.

Figure 5 shows the restraint pin-socket geometry prior to missile launch. Note that the socket contacts the forward side of the pin. This is because the missile and canister are elevated to a launch position of 38 degrees and the resultant weight of the missile is held by the pin.

Angle θ in Figure 5 can be defined as $\text{arc cos } B/R$ where:

$$R = \sqrt{A^2 + B^2} .$$

Figure 6 shows the geometry at launch just as the forward edge of the pin clears the bottom edge of the socket. This is a minimum pin clearance condition. The forward edge of the pin has dropped distance C , so that the vertical height from the pivot point is now $B-C$. The angle ϕ is thus defined as:

$$\text{arc cos } \frac{B-C}{R}, \text{ where again } R = \sqrt{A^2 + B^2} .$$

The angle of tilt α equals,

$$\phi - \theta \text{ or } \alpha = \text{arc cos } \frac{B-C}{\sqrt{A^2 + B^2}} - \text{arc cos } \frac{B}{\sqrt{A^2 + B^2}} .$$

From Figure 6, the projected pin diameter $F = \frac{D}{\cos \alpha}$. If F equals socket diameter for worst case condition, then we can define the minimum gap X needed between pin diameter and socket diameter as:

$$F - D = \frac{D}{\cos \alpha} - D \text{ or } X = D \left(\frac{1}{\cos \alpha} - 1 \right) .$$

Substituting the term derived for α , X can be defined as:

$$X = D \left[\frac{1}{\cos \left(\arccos \frac{B-C}{\sqrt{A^2 + B^2}} - \arccos \frac{B}{\sqrt{A^2 + B^2}} \right)} - 1 \right]$$

For the PATRIOT missile system the depth of pin C and the pin diameter D were frozen from the old design. Values for A and B were selected to be 1.97 inches (50.04 mm) and 4.40 inches (111.76 mm) respectively. These values were based partly on space limitation and structural convenience. Substituting these values for A, B, C and D in the above equation, the value of X is 0.0059 inch (0.150 mm) causing line to line contact between pin and socket (Figure 6). The existing difference between minimum socket diameter and maximum pin diameter is 0.0155 inch (0.394 mm). This is far more than the minimum required for system operation.

CONCLUDING REMARKS

The fly-away restraint pin mechanism has been functionally and structurally tested (including a short burn, full scale missile fly-out test) with complete success. This mechanism is very cost effective, representing an approximate 50 percent saving over the initial design.

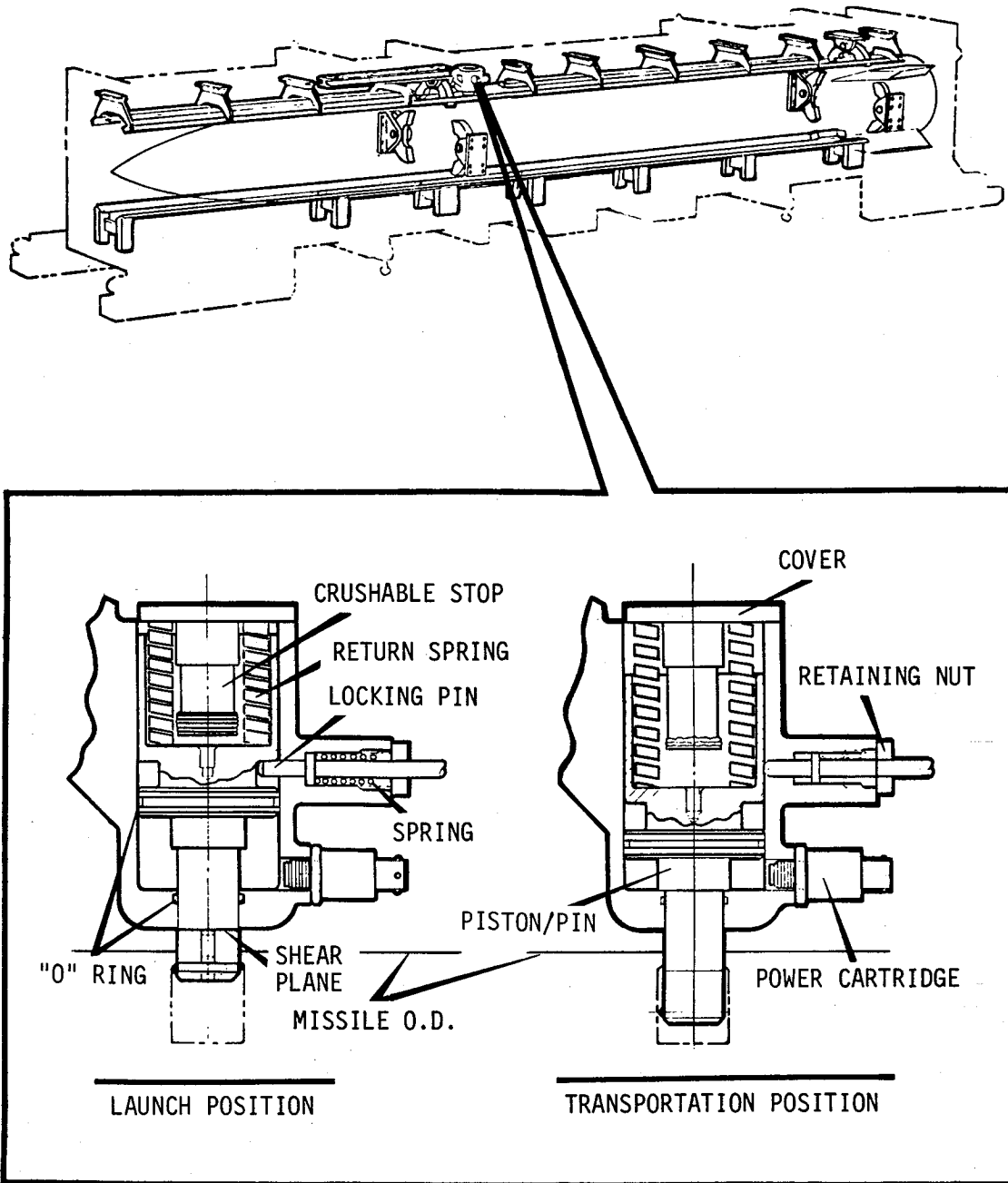

Figure 1. Ordnance-Driven Restraint Pin - Initial Design

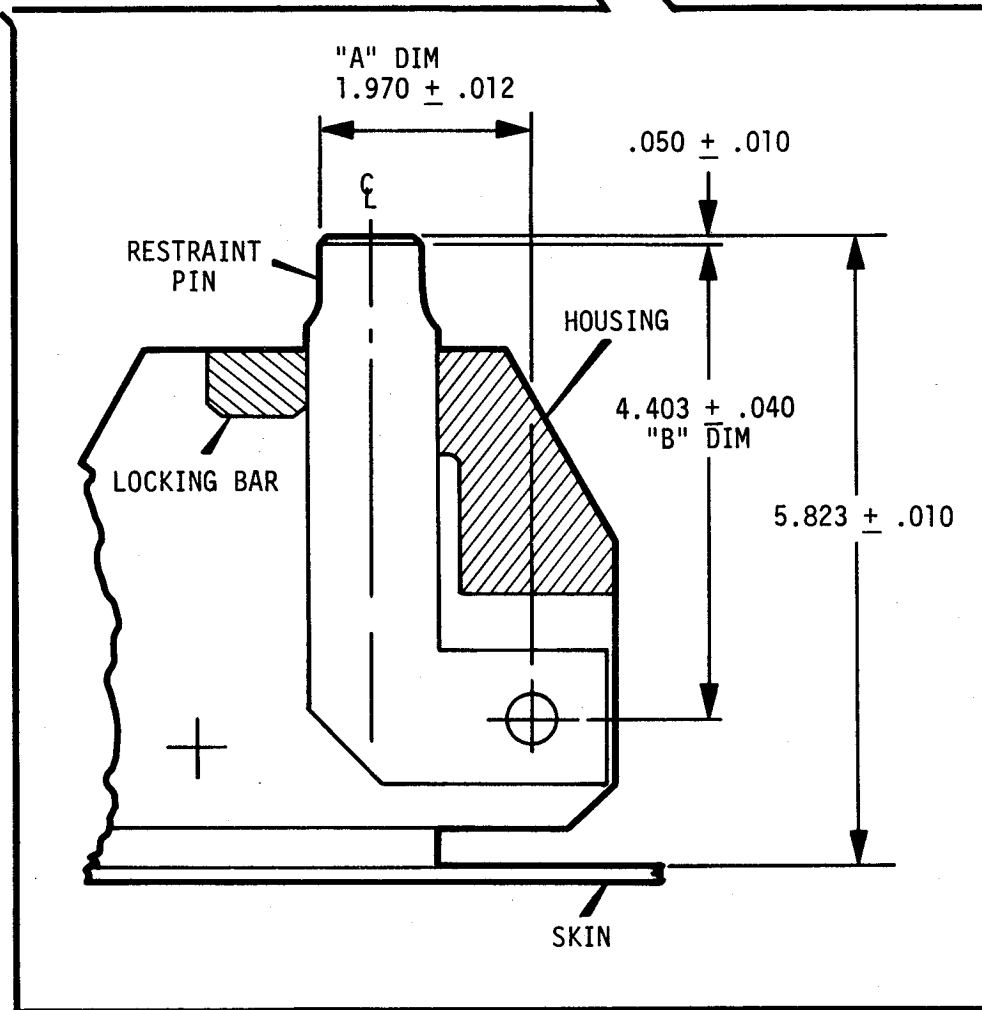
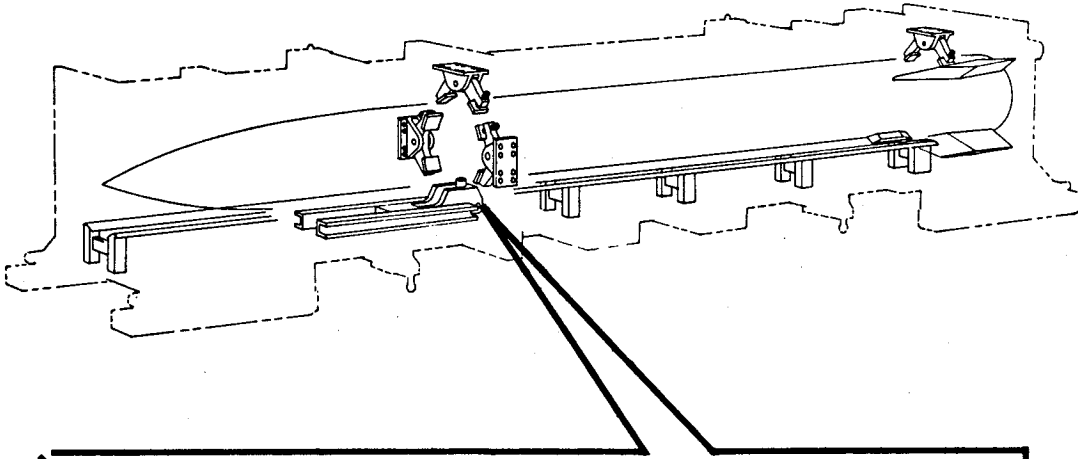

Figure 2. Fly-Away Restraint Pin - New Design

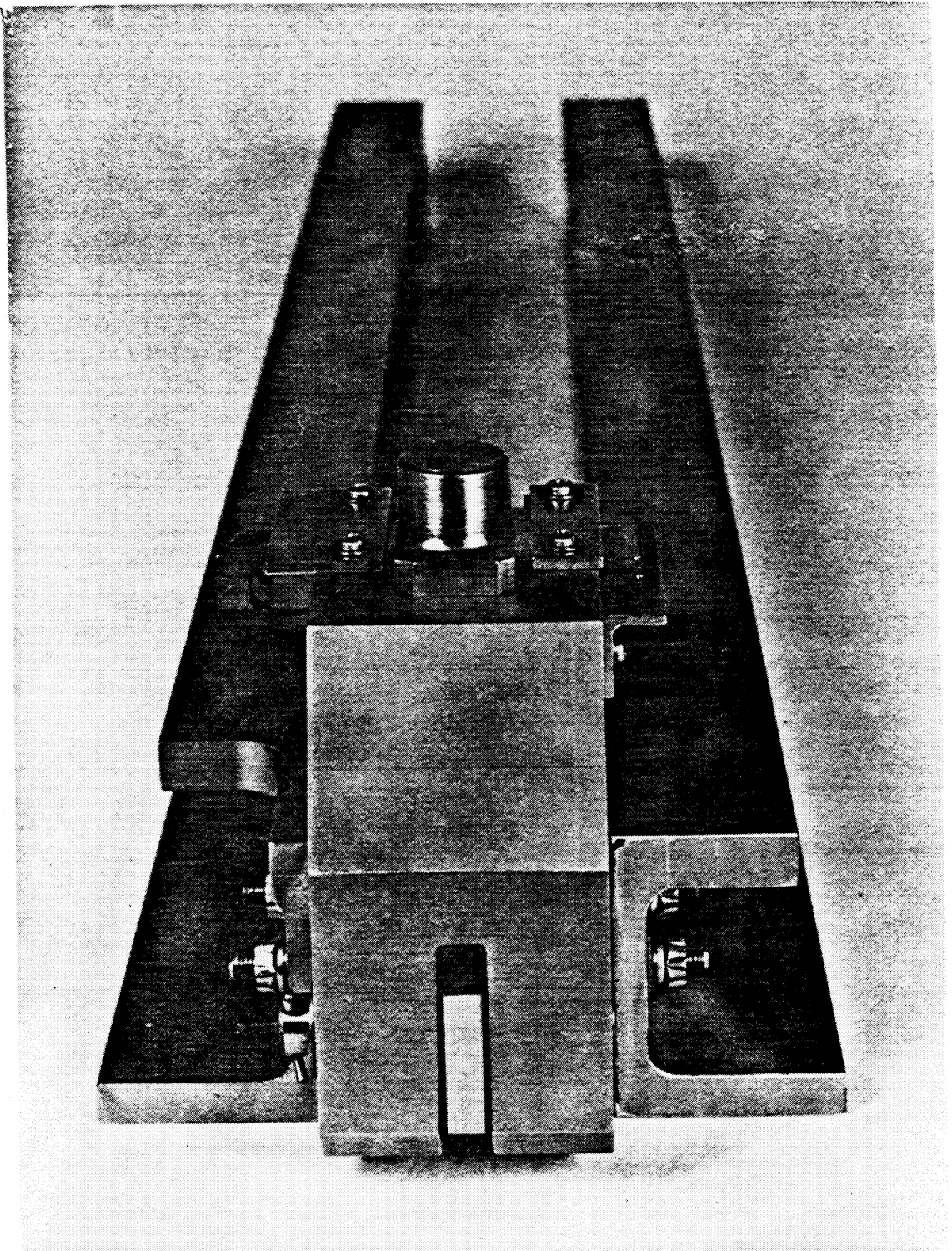

Figure 3. Restraint Pin Position at Pre-Launch

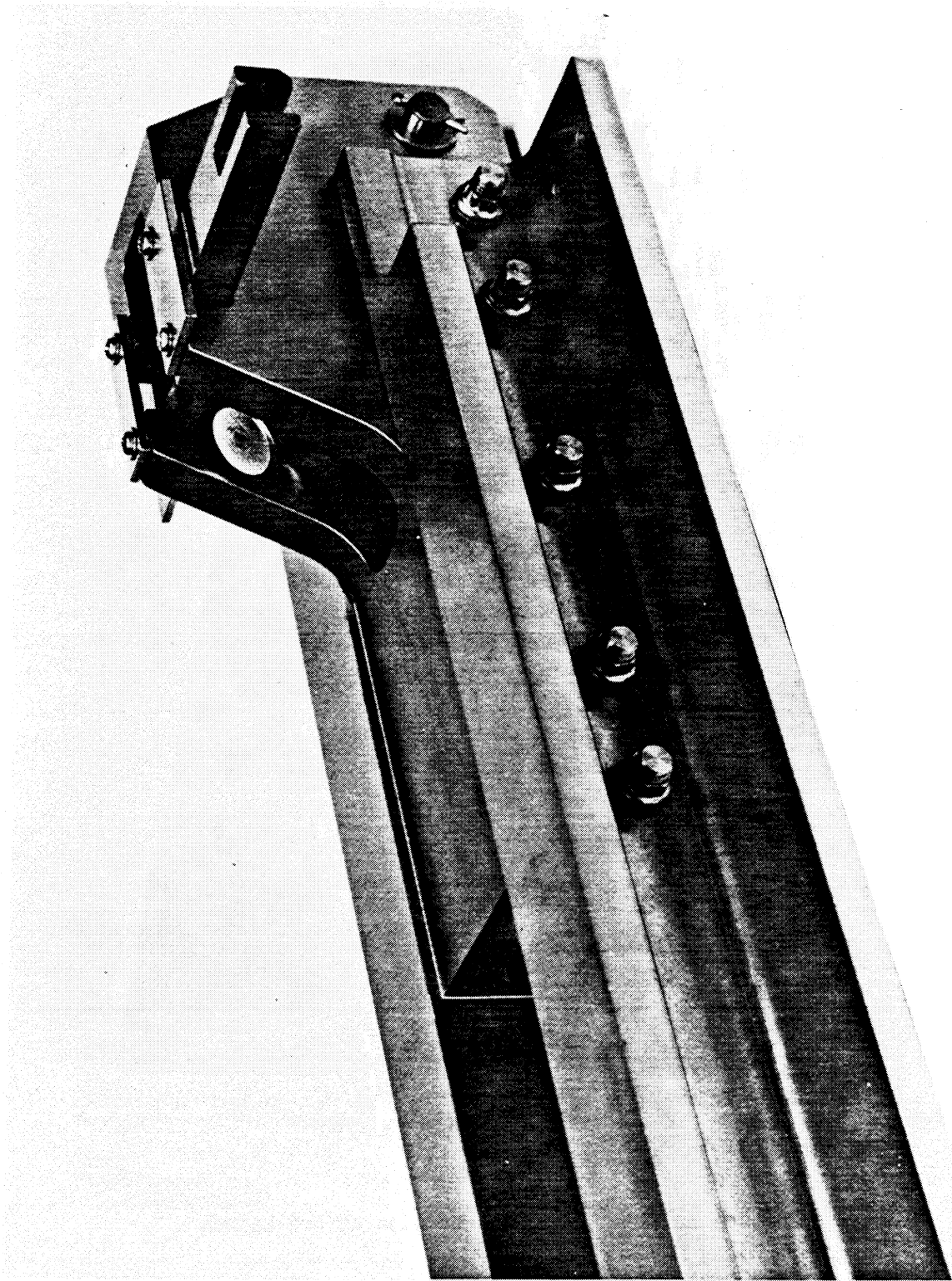

Figure 4. Restraint Pin Position at Post-Launch

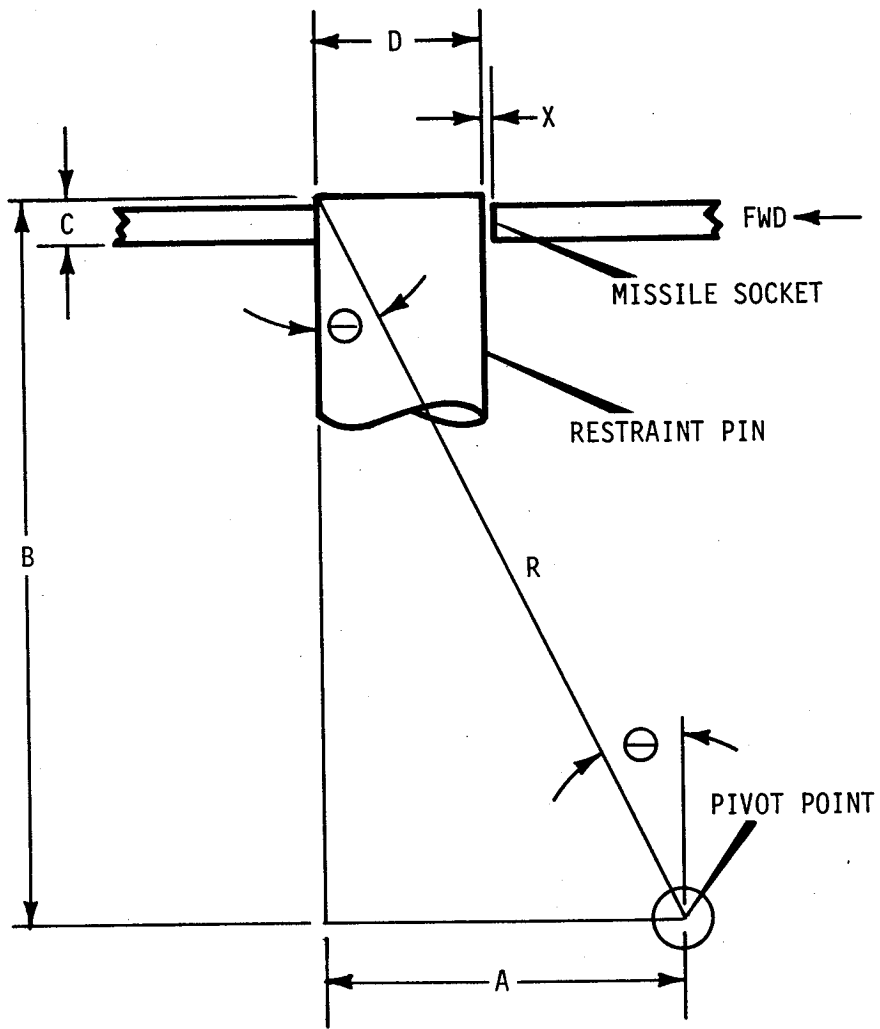

Figure 5. Position of Restraint Pin at Pre-Launch

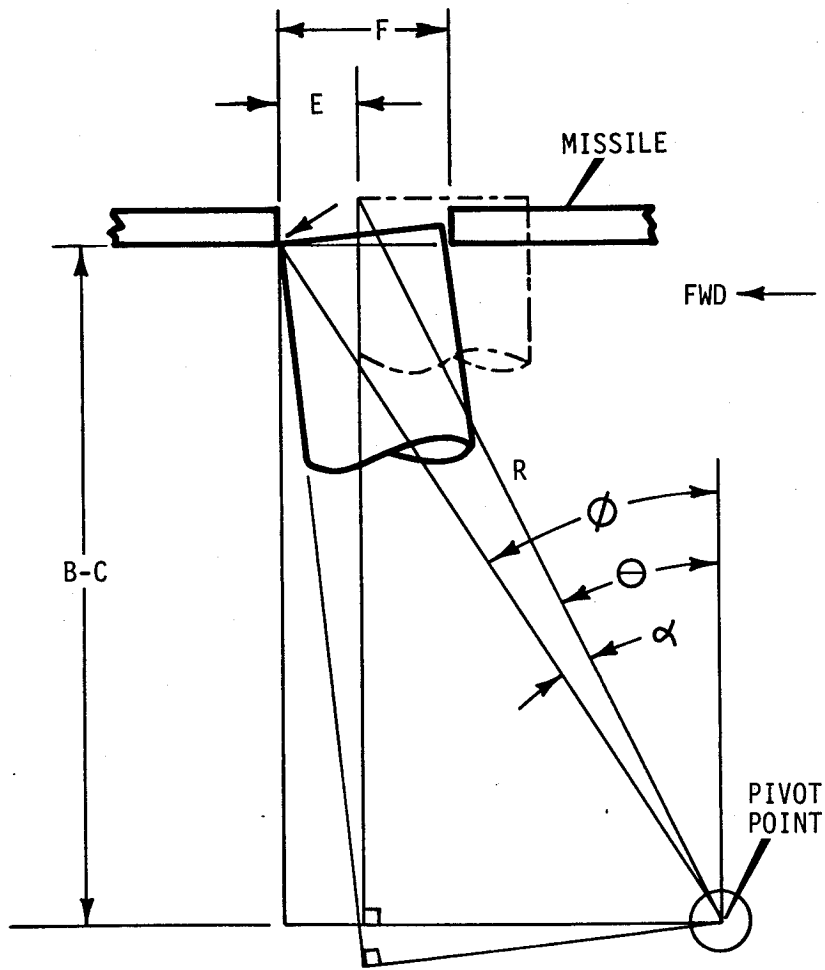

Figure 6. Position of Restraint Pin Just as Forward Edge Clears the Missile Socket at Post Launch