

THE MJS-77 MAGNETOMETER ACTUATOR

By William C. Stange

NASA Goddard Space Flight Center

SUMMARY

A two-position (0° and 180°) actuating mechanism (flipper) driven by alternately-heated wax motors (pellets) will be used to rotate the low field triaxial fluxgate magnetometer experiment on the 1977 Mariner Jupiter-Saturn spacecraft to its 0° and 180° positions. The magnetic field, power requirements, weight and volume of this device are very restrictive. The problems encountered in design and development of this mechanism are presented.

INTRODUCTION

The purpose of this experiment is to provide precise, accurate, and rapid vector measurements (from 0.01γ to 20 gauss, $1\gamma = 10^{-5}$ gauss) of the magnetic fields of Jupiter and Saturn in interplanetary space to them and beyond. These data extend in situ studies of the solar wind interaction with Jupiter and characteristics of its magnetic field and yield first studies of Saturn's field and its interactions if the solar wind extends to 10 AU.

Performing accurate measurements of magnetic fields on a spacecraft not fabricated magnetically clean is a major problem. A moderately long boom will be used to place two low-field ($\leq 6400\gamma$) triaxial fluxgate magnetometers at remote distances from the spacecraft. Simultaneous measurements will yield separate estimates of the spacecraft field and the ambient field.

The purpose of this essentially nonmagnetic actuator is in-flight calibration of the triaxial fluxgate magnetometers. This calibration, which determines the sensor zero point, is accomplished by periodically flipping the magnetometers by 180 degrees.

The advantages of this mechanism are that it satisfies more than any other known device, the constraints of volume, weight, nonmagnetic materials, and power in relation to the requirements of high torque, fast cycling and long life in the hard vacuum of space and exposure to intense radiation fields at Jupiter. These properties are derived solely from the unique mechanical qualities of the pellet. This actuator will provide cyclical bi-directional rotary motion under varying environmental temperatures (-45°C to $+65^\circ\text{C}$) in a vacuum for periods up to five years.

This paper describes the mechanical and electrical functions of the design which evolved, as well as the problems encountered. The objectives achieved are evaluated and other possible applications are presented.

OBJECTIVE

The objective was to develop an actuator which would meet the following requirements.

1. Rotate 180 degrees \pm 15 minutes of arc.
2. Remain at the indexing stop until again actuated.
3. Have a permanent magnetic field (when not being powered) less than 0.1γ at 1.27 cm (1/2 in).
4. Have a minimum capability of 300 cycles during a period of five years.
5. Require not more than 11 watts of power.
6. Weigh less than 0.227 kg (0.5 lb).
7. Fail-safe indexing, i.e., the actuator must not stop in any position other than 0 or 180 degrees.
8. Operate within the temperature range of -45°C to $+65^{\circ}\text{C}$.
9. Operate in a vacuum.
10. Complete the rotational indexing within 4 minutes of initiation.

DESIGN

The selection of a design approach required the consideration of other feasible concepts. Among those reviewed were bimorph piezoelectric devices, opposing coil solenoids (without cores), nonmagnetic electric motors, Freon state conversion bellows, and NITINOL actuators.

A concept utilizing pellets was adopted because it appears to most reliably meet the above design requirements.

PELLET

In 1965, McCarthy, et al., of Goddard Space Flight Center developed an oscillating magnetometer actuator which initiated the utilization of the wax pellet as its power element (see Reference 1). The pellet is a standard production line component* which is used in thermostats produced by the Harrison Radiator Division, General Motors Corp. It consists of a brass case with a rubber boot, an expansion material, and a piston. Figure 1 represents the basic configuration. The expansion material is Epolene and paraffin wax to which a fine copper powder has been added to improve the heat conduction. The

*Part No. 3005031, Harrison Radiator Division, General Motors Corporation

Epolene and paraffin proportions are adjusted to obtain the desired melting point. The solid to liquid transition of this material yields a 14% volumetric increase. Thus when the applied heat raises the material's temperature to the melting point, the material expands and presses the rubber boot against the conical tip of the piston, forcing it outward.

The magnetic requirements of the MJS-77 magnetometer experiment necessitated some modifications to the basic production line pellet. A survey of pellet production line components with a magnetometer allowed selective use of all components except the piston, flange seal and expansion material. A simple substitution of different materials eliminated the magnetic problem with the production line piston and flange seal; namely, titanium for the stainless steel piston and beryllium copper for the brass flange seal. The magnetic problem with the expansion material was found to be in the copper powder. The production line copper powder is processed with steel balls which contaminated the resulting product. After an exhaustive search and many trials, a magnetically clean copper powder was obtained which was processed with ceramic balls.

The developmental nature of these extremely magnetically clean pellets required that they be hand assembled and tested in a clean room environment with all components being checked with a magnetometer during all stages of fabrication. The Harrison Radiator Division of General Motors Corporation at Lockport, N. Y. in conjunction with NASA personnel successfully produced enough magnetically clean pellets to insure the ultimate success of this effort.

The pellet which was finally developed weighs 26 grams with 750 milligrams of expansion material and will produce a maximum force of 15.88 kilograms (35 lbs) with a stroke of 1.14 cm (0.450 inches). A summary of the pellet characteristics is presented in Table 1.

MECHANICAL OPERATION

The flight mechanism as shown in Figure 2 is simply an experiment container (triaxial fluxgate magnetometer) which can be bi-directionally rotated by heating either of two opposing pellets, whose indexing is biased by two over-center Flexator springs. When commanded, the function of the flipper is to rotate the triaxial fluxgate magnetometer 180° counter-clockwise from the position shown and then, when later commanded, to rotate the magnetometer back 180° clockwise to the original position.

As shown in Figures 2 and 3 the crank arm holds the contact against the left position stop, thus completing an electrical circuit. To rotate the magnetometer 180° counter-clockwise, the right pellet (Fig. 4) is heated to 100°C by a heater which is bonded to its cylindrical surface. The pellet is filled with a special wax and copper powder mixture, which undergoes a 14% volumetric increase in changing from its initial solid state to a liquid state. The internal pressure thus created squeezes a rubber boot (Fig. 4) which forces the piston out of the rubber boot. The shoulder of this piston bears against the right beam (Fig. 4) and causes the toggle to rotate counter-clockwise. The toggle is tied

to the shaft through a pin which travels in the toggle slot. As the toggle starts to rotate, it bears against the pin (Figs. 4 and 5A) and rotates the shaft and all members attached to it. When the crank arm rotates counter-clockwise about 100° (Fig. 5B) the two Flexator springs flip the shaft (magnetometer) the remaining 80° (Fig. 5C), which the slotted toggle allows, thus completing the 180° flip (Fig. 5D). This flip is sensed by the opening of the left contact to position stop (Fig. 3) opening the miniature switch (Fig. 3) and the closing of the right contact to position stop (Fig. 3). When the right piston extended from the pellet it compressed a spring which, as the liquid wax again solidifies forces the piston back into its pellet. The magnetometer can now be flipped 180° clockwise back to the position as shown in Figures 2, 3 and 4 by heating the left pellet and repeating the above process.

MATERIALS

The prime considerations in the selection of materials for this mechanism were low magnetic permeability (<1.001), volume and weight. The Flexator springs were made of Elgiloy, the bushings, housing and experiment container from Delrin, and the shafts and other hardware from titanium alloy, beryllium copper, aluminum and brass.

CONCLUSION

The mechanism described in this paper provides positive, cyclical indexing for a sensor rotating 180 degrees ±15 minutes; the permanent magnetic field is less than 0.1γ at 1.27 cm (1/2 in), the power consumed is less than 33 watt-minutes, the weight is less than 0.227 kg (8 oz), and the volume (less the experiment container) is less than 577 cubic centimeters (35.2 cubic inches).

Eight mechanisms have been fabricated: four flight models, two prototype models, and two engineering test units. These units have been environmentally qualified at temperatures ranging from -35°C to +40°C in vacuum. The flip times varied from 225 seconds at -35°C to 110 seconds at +40°C. The flight and prototype models have been shipped to the Jet Propulsion Laboratory for integration aboard the two MJS-77 spacecraft to be launched between August and October 1977. The two engineering test units have been life tested for up to 750 flips each through the temperature ranges of -35°C to +40°C in vacuum with no apparent change in operating characteristics.

REFERENCE

1. McCarthy, Dennis K., "Nonmagnetic, Lightweight Oscillating Actuator." NASA/GSFC X-723-70-166.

Table 1

Pellet Characteristics

Start to open temperature	72°C
Start to open tolerance	±1°C
Piston travel	1.14 cm (0.450 in) 0.95 cm (0.375 in) minimum travel after 10,000 cycles
Linear rate	0.023 cm/°C (0.005 in/°F)
Piston force	15.88 kilograms maximum (35 lbs)
Force required to return piston	3.62 to 4.54 kilograms (8 to 10 lbs)
Temperature fully open	92°C to 105°C depending on return spring force
Time to open	3 to 4 minutes, depending on initial temperature
Time to close	1 to 1.5 minutes
Life	10,000 cycles minimum
Advantages	Compact, lightweight and forceful
Disadvantages	Must allow for over travel. Requires a heat source.

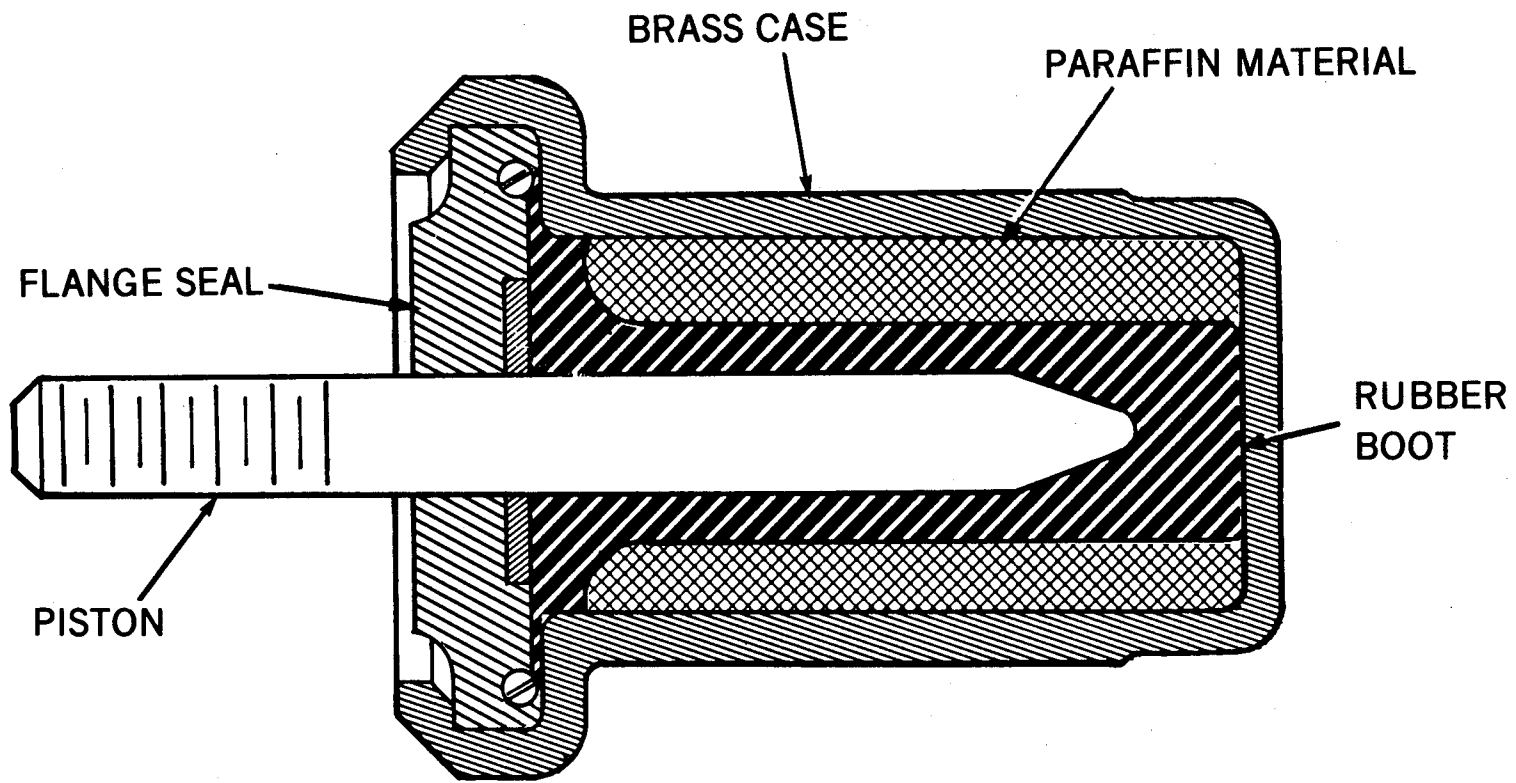

Figure 1. Wax Pellet

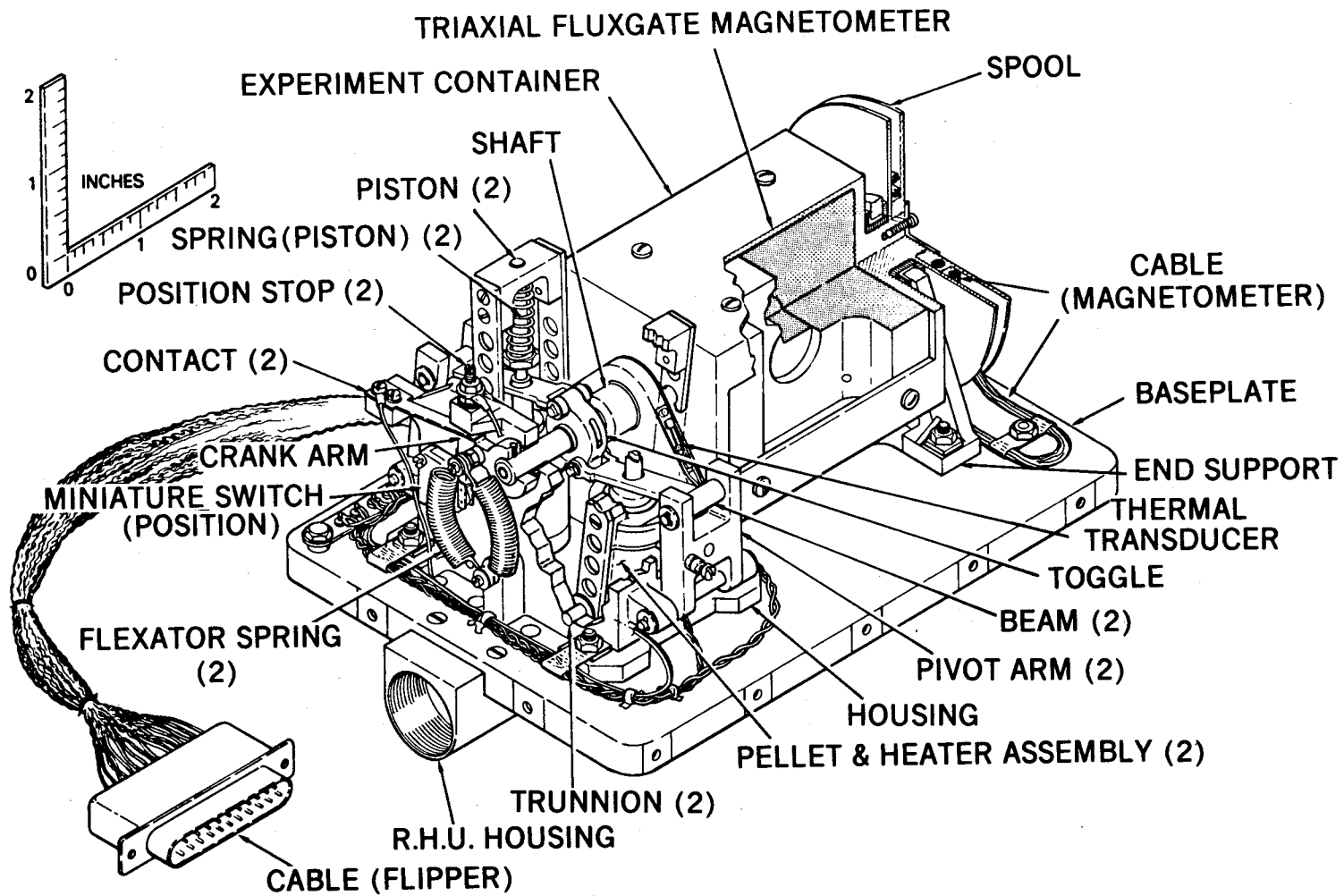

Figure 2. MJS-77 Magnetometer Flipper Assembly

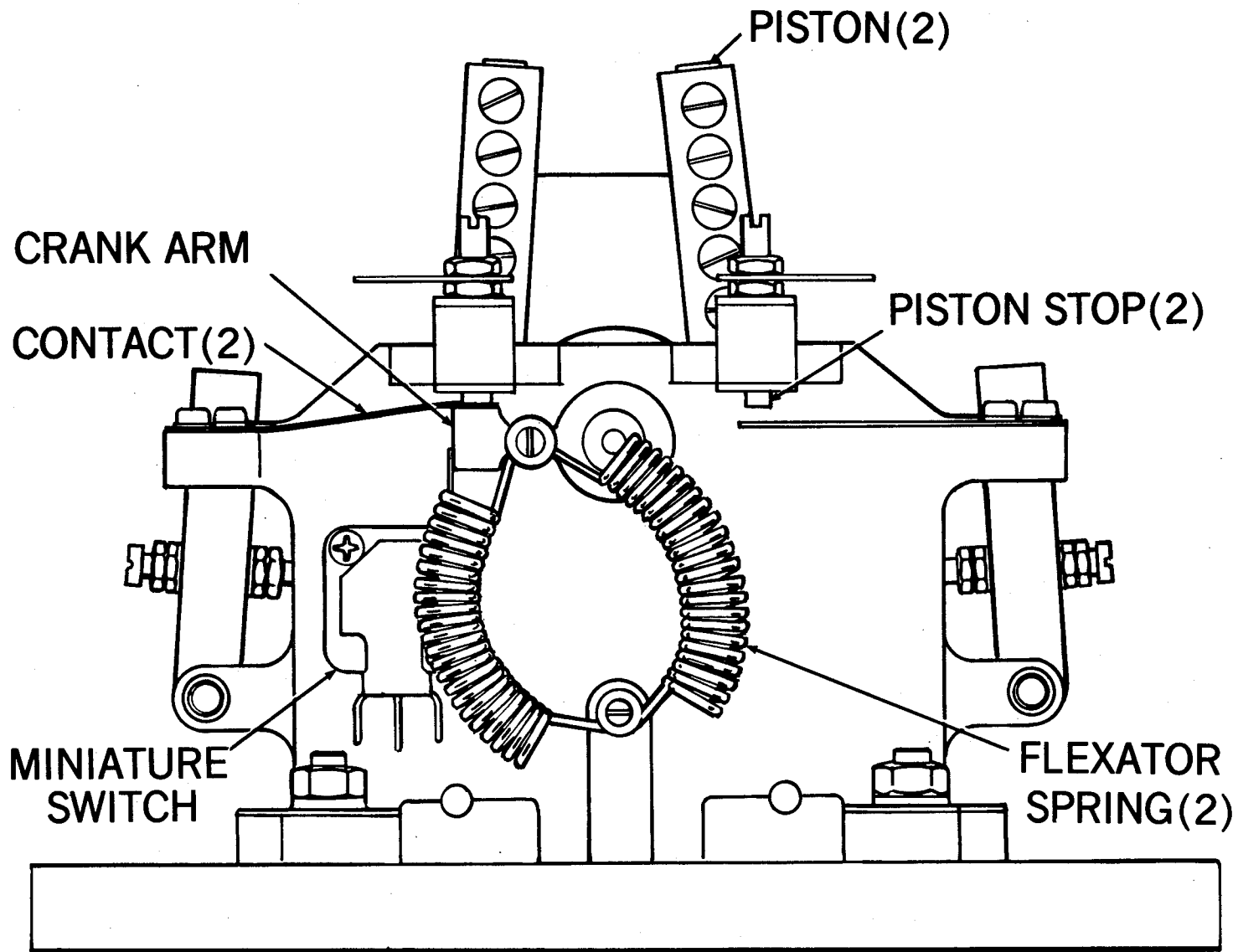

Figure 3. End View

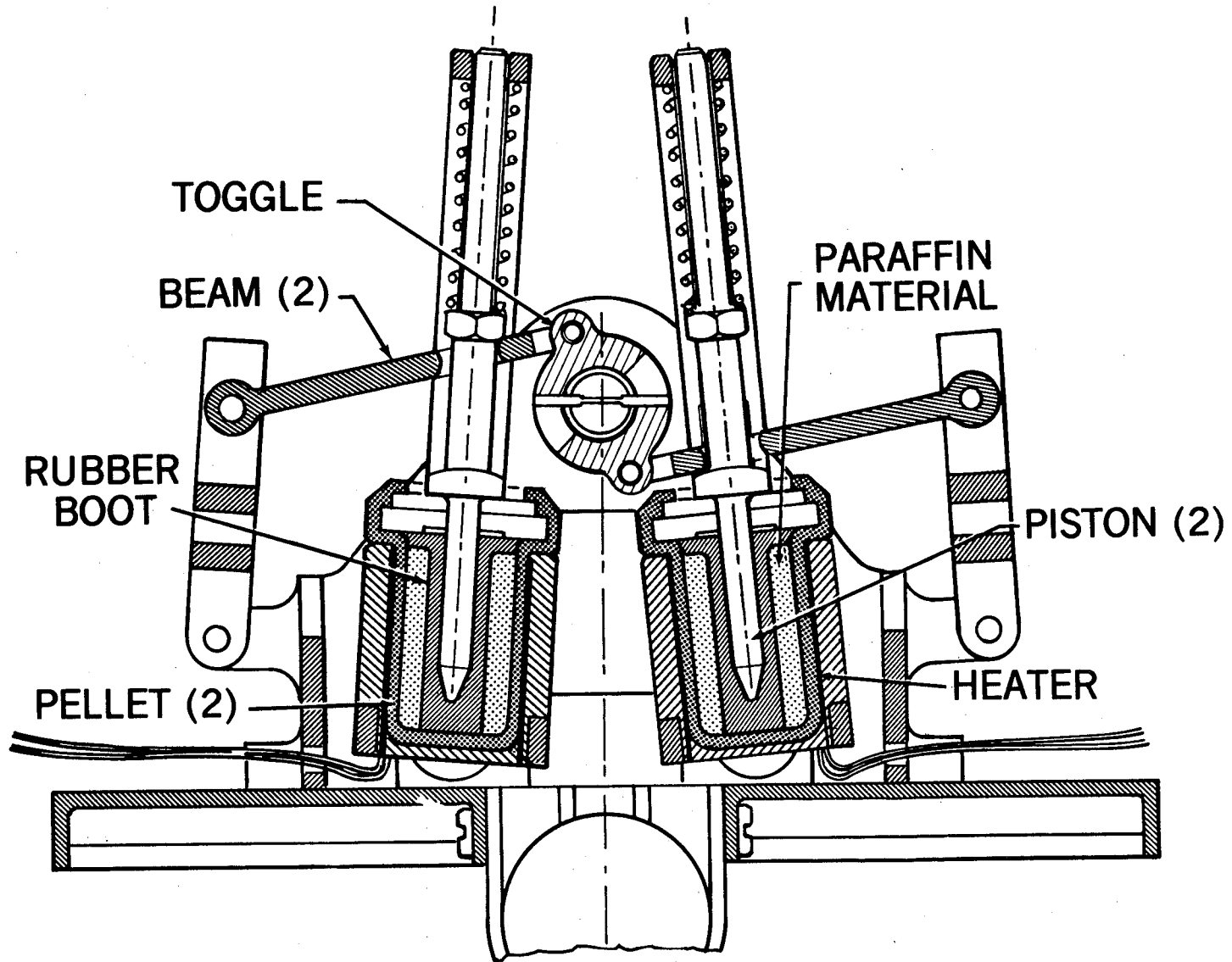

Figure 4. Flipper Section View

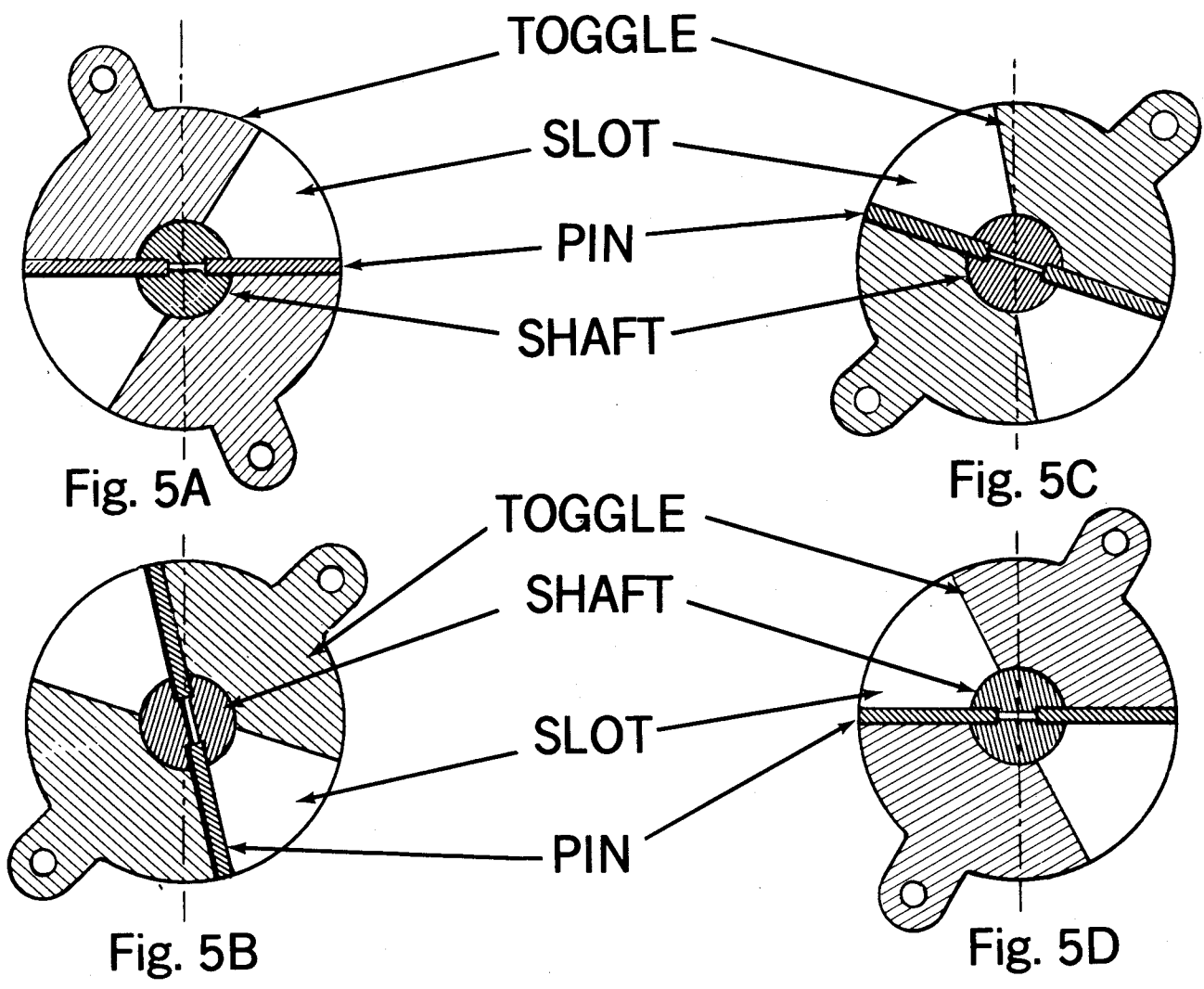

Figure 5. Toggle Section Views