

AN ACTIVE NUTATION DAMPER
FOR SPACECRAFT

by

Richard A. Abercrombie

and

Dr. Thomas W. Flatley

Goddard Space Flight Center

ABSTRACT

An active nutation damping device, consisting of an angular accelerometer, a dc-motor-driven flywheel, and associated electronics, has been developed for spacecraft use. This damping system was used on the LAGEOS spacecraft, launched May 4, 1976, to control nutation buildup during the long coast period (approximately 75 minutes) after the third stage separation.

Of the many electrical and mechanical design choices involved, the use of an angular rather than linear accelerometer offers some advantages. There are, however, some problems of adapting the angular accelerometer to spacecraft use.

The damper package was evaluated and proven on a three-axis gas-bearing simulator that duplicated the LAGEOS spacecraft critical flight dynamics. In addition, a failure analysis of the damper assembly was performed.

Performance of the damper during the LAGEOS flight has confirmed the pre-flight evaluation and analysis.

INTRODUCTION

The Active Nutation Damper was developed to combat nutational instability of spinning spacecraft, particularly for spacecraft using long coast periods during a transfer orbit prior to firing an apogee kick motor (AKM).

This active damper was first used with the Laser Geodynamic Satellite (LAGEOS) which is a 906 lb. 2 foot diameter sphere

launched into a near-circular, near polar orbit on May 4, 1976. The purpose of the satellite is to demonstrate relevant space techniques that will contribute to the development and validation of predictive models for earthquake hazard alleviation, ocean surface conditions, and ocean circulation. The satellite is tracked by measuring laser beam reflections from a set of 426 corner reflectors which cover its surface.

The LAGEOS had an unfavorable moment of inertia in its transfer orbit and was thus nutationally unstable. Uncertainties in the estimation of the energy dissipation characteristic of the LAGEOS assembly during the long transfer orbit, particularly within the rubbery solid propellant of the AKM, dictated the use of a device to reduce any nutational coning that might occur because of this instability. Thus, the LAGEOS Active Nutation Damper (LAND) was developed for this specific purpose.

SYSTEM DESCRIPTION

The active nutation damper system consists primarily of an angular accelerometer, a dc motor driven flywheel and associated electronics. All components are mounted in a single cubical box with the accelerometer input axis perpendicular to the motor/flywheel axis of rotation. On the spacecraft, these axes must also be perpendicular to the nominal spin axis (Figure 1). Since the angular accelerometer is insensitive to translational motion and the relative orientation of the accelerometer and motor in the box are fixed, no other position or alignment requirements exist. That is, the damper unit may be mounted in any position provided the plane of the accelerometer/motor is normal to the spacecraft spin axis and, for phasing, the proper end of the housing is up. Thus, the angular accelerometer has an alignment advantage compared to the precise alignment requirements necessary when using linear accelerometers or gyros. It should be noted that the availability of angular accelerometers, space qualified or not, is very limited. This led to problems in the test program which will be discussed later.

Digital electronic circuitry was used to divide the nutation period into 8 parts. Using positive-going zero crossings of the accelerometer signal as a reference, it drove the motor positive for one fourth of a nutation cycle starting at one eighth of the period, then off for a quarter of a cycle. Figure 2 shows this logic schematically and illustrates the actual flywheel speed achieved relative to the optimum.

GENERAL DESIGN DETAILS

Figure 3 illustrates the overall dimensions and locates the components that make up the damper assembly. The assembly includes the power converter, accelerometer, reaction wheel, and associated electronics. The dc-to-dc regulated converter is designed to put out ± 15 volts with inputs ranging from 24 to 32 volts. The converter output will power the accelerometer and the control electronics. The angular accelerometer is operated with the ± 15 volts and will give a ± 5 volt functional output. Full scale output represents an input acceleration of 0.5 rad/sec^2 .

The control electronics measure the period of the nutation signal and uses this information to properly phase the reaction wheel drive to reduce the spacecraft nutation. The reaction wheel is made up of a 28 V dc torque motor rotor and a stainless steel flywheel. This unit is mounted on pre-loaded, duplex, back to back, paired bearings directly to the housing at right angles to the accelerometer. The motor is energized by suppressed contact relays driven by the control electronics. A wiring diagram of the LAND system is shown in Figure 4. A relay is provided to enable the system to be operated either internally or externally. Power is furnished through this relay to the 28 volt bus which, in turn, furnishes power to the converter, the accelerometer, and the electronics. Power is not furnished to the relays that operate the motor until an additional relay is activated by a spacecraft timing or separation switch. Thus, the system, with the exception of the reaction wheel, may be turned on prior to launch. This allows accelerometer and power telemetry to be received throughout launch, while holding off reaction wheel operation until needed.

MECHANICAL CONFIGURATION

The damper package is basically a 20.3 cm (8 inch) cubical box, weighing approximately 7.5 kilograms (16.6 lbs.). Flanges, that are an integral part of the housing, are provided for mounting. The active nutation damper assembly interfaces mechanically with the spacecraft through a mounting bracket which rigidly attaches and transfers the torque loads from the damper assembly to the spacecraft and positions the assembly to a specified orientation.

The reaction wheel incorporates a flywheel driven by a frameless dc, permanent magnet torque motor (Figure 5) with the rotor mounted to the flywheel and the stator mounted to the housing. The reaction wheel bearings are pre-loaded and lubricated with Krytox to reduce friction and wear between moving parts, to dissipate heat, and to prevent corrosion of critical surfaces. The bearing and lubrication are protected from contamination by a labyrinth seal.

TEST PROGRAM

The LAND system was subjected to a test program to generate performance data and to prove its capability of meeting the LAGEOS flight requirements. Engineering tests were run on the breadboard unit proving the electronic design. Performance tests of the complete unit were conducted before and after vibration, EMI, and thermal vacuum tests. Two complete LAND units were constructed. One unit was environmentally qualified at Flight Prototype levels to be used as a flight spare. The other unit was tested at Flight Acceptance levels, and was the flight unit.

Mechanical Stimulation Test

All major components were subjected to pre-assembly performance checks. The accelerometers were mechanically stimulated using a single axis air bearing table mounted on a seismic block. Four large arms, equally spaced from each other, were secured to the floating portion of the air bearing assembly. Cables were attached to the ends of opposing arms, then passed over pulleys and attached to weights (Figure 6). Thus, if the whole floating arrangement were deflected a few degrees and then released, it would oscillate at varying frequencies depending on the quantity of equal weights applied to the opposing arms. Weights were added until a frequency of 1.3 Hz (the calculated LAGEOS nutation frequency) was reached. The large mass of this arrangement allowed the table to oscillate at a specific frequency fairly constantly for a short period of time. The complete system was placed on a seismic block to effectively isolate the sensitive accelerometer from various building vibrations. With the LAND unit mounted to the center of this arrangement and powered up through a connector, a functional test of the accelerometer, reaction wheel, threshold level, and phasing was conducted visually and recorded as the table was oscillated. This test revealed that movement of wires carrying a 10 MHz accelerometer oscillator signal produced a noise level that exceeded the threshold level of the system. This problem was solved by shortening the cable between the electronics and the sensing unit of the accelerometer, conformal coating all wires carrying this 10 MHz signal so they could not move, and filtering all accelerometer inputs and outputs with RC networks.

Gas Bearing Test

The active nutation damper package was evaluated and proven on a 3-axis gas-bearing simulator (Figure 7) that duplicated the LAGEOS critical flight dynamics. The spin rate and spin and transverse inertias of the simulator were made to be equal to that of the LAGEOS spacecraft in transfer orbit. Testing was conducted under vacuum in a dynamic test chamber. Nutation was induced in the simulator and both the flight and back-up LAND units were activated for full scale performance tests. These tests verified that the

LAND system would reduce nutation at the predicted rate of one degree per minute.

FLIGHT PERFORMANCE

The LAGEOS spacecraft was successfully launched May 4, 1976. The LAND system was turned on just prior to launch except for power to the motor driven flywheel. The angular accelerometer and electronics were powered up prior to launch as a functional check and to provide accelerometer telemetry data during the launch phase. The reaction wheel was furnished power through a timing switch closure which occurred shortly after third stage separation, at which point the long coast (4500 seconds) transfer orbit started. Telemetry indicated that the LAND system's motor/flywheel was activated as the timing switch closed. The nutation at the beginning of the long coast period was 0.6 degrees which was greater than the 0.38 degrees threshold of the logic circuitry. Thus, the LAND's motor turned on and it operated for a period of approximately 20 seconds, reducing nutation to 0.25 degrees. This performance verified the nominal pre-flight prediction of 1.0 degree per minute for the nutation control capability of the damper. The balance of the long coast period was completed without sufficient nutation growth to re-start the LAND system.

CONCLUDING REMARKS

The most significant features of this development program may be summarized as follows:

(1) This was the first time an angular accelerometer has been used for sensing spacecraft nutation.

(2) This was the first time an active nutation damper made use of internal torquing to control nutational coning.

(3) The flight capability of this active nutation damping system has been proven by the LAGEOS launch.

(4) This damper design is particularly suitable to those spacecraft without gas control systems that require long coast transfer orbits.

(5) This system can easily be adapted to fire jets for gas control of nutational coning.

ACKNOWLEDGMENTS

Credit is due to Henry Hoffman and James Donohue of the Stabilization and Control Branch, Goddard Space Flight Center, for the conceptual design of this damper system.

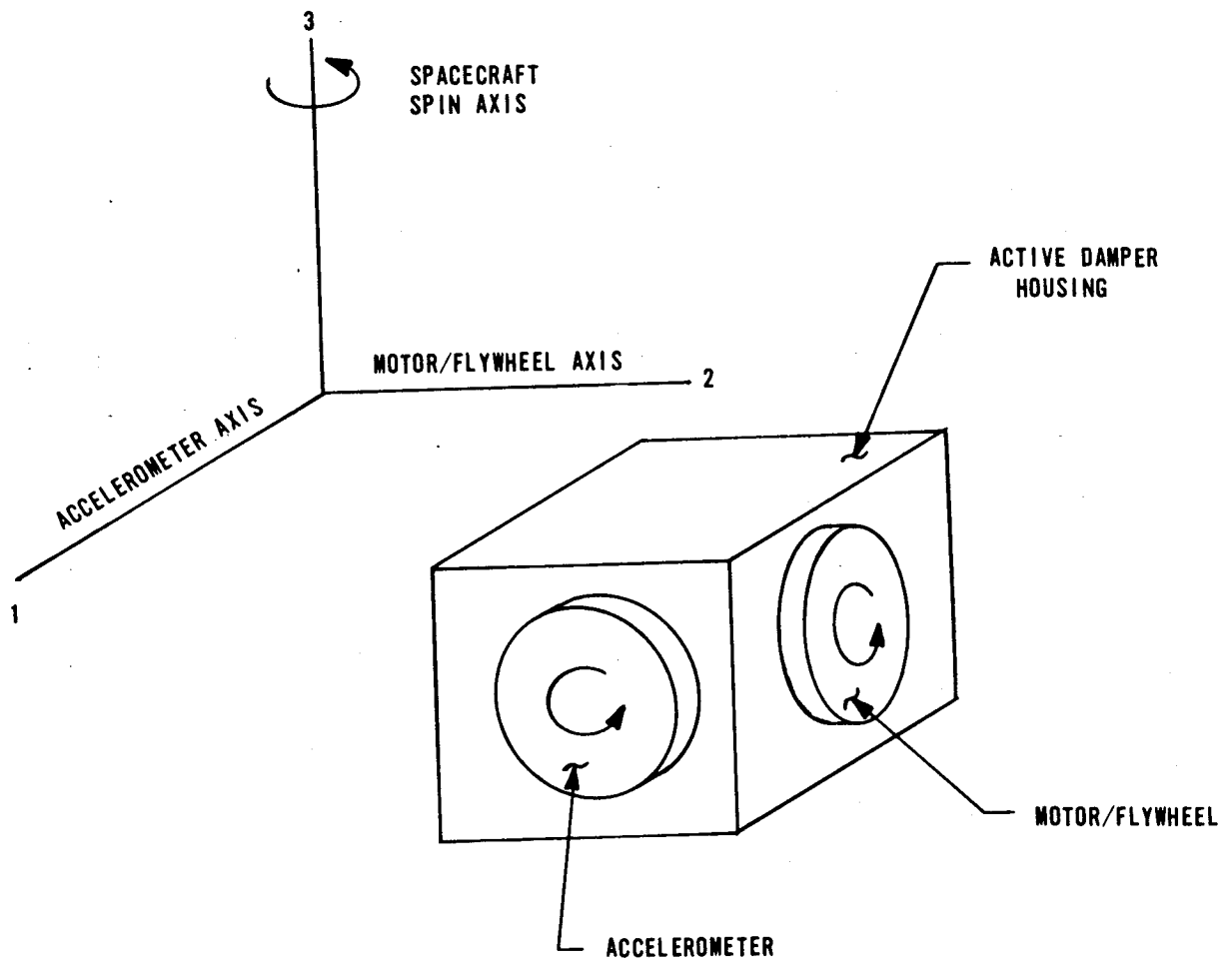

Figure 1. Active Nutation Damper Configuration

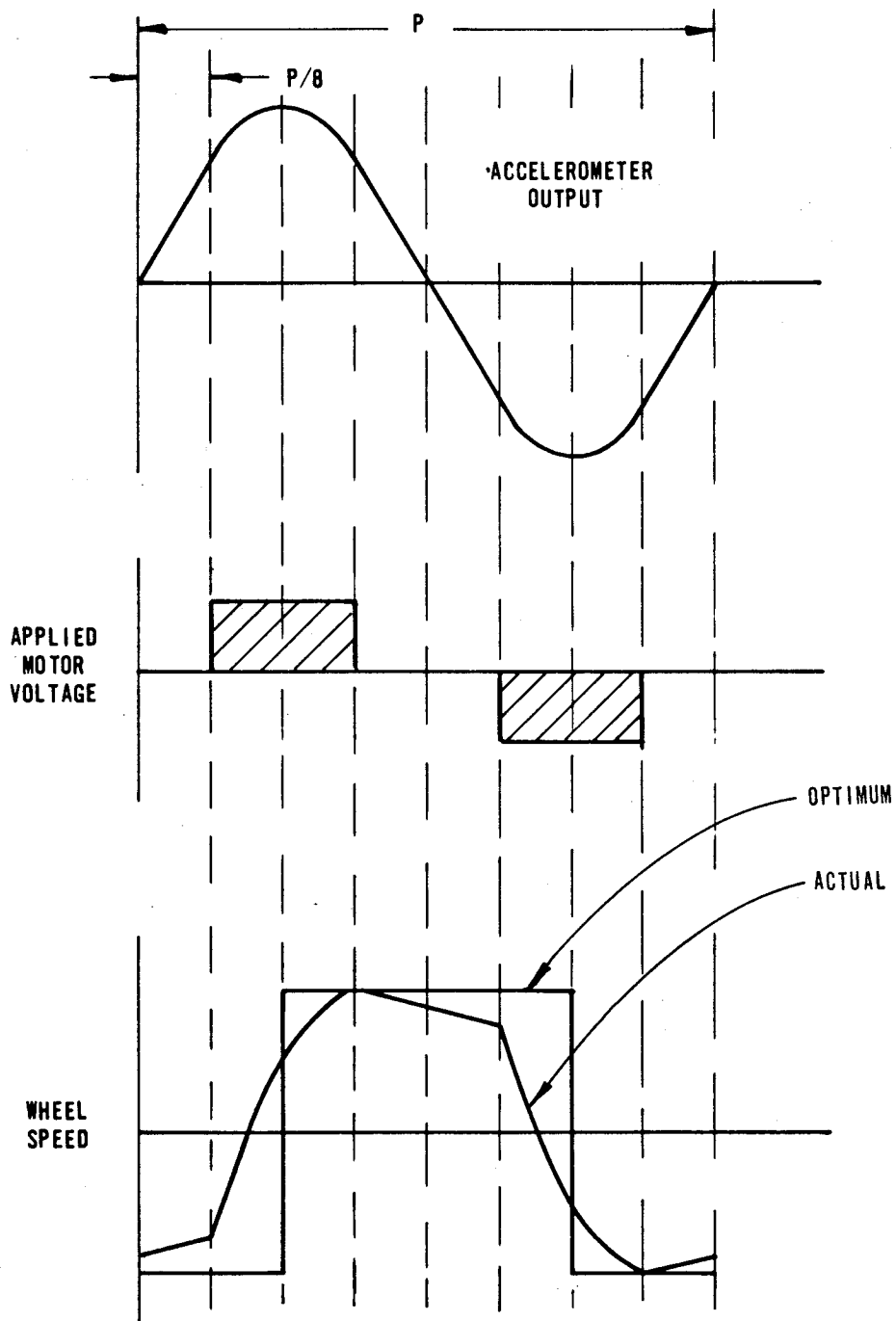

Figure 2. Actual Flywheel Speed Achieved Relative to the Optimum

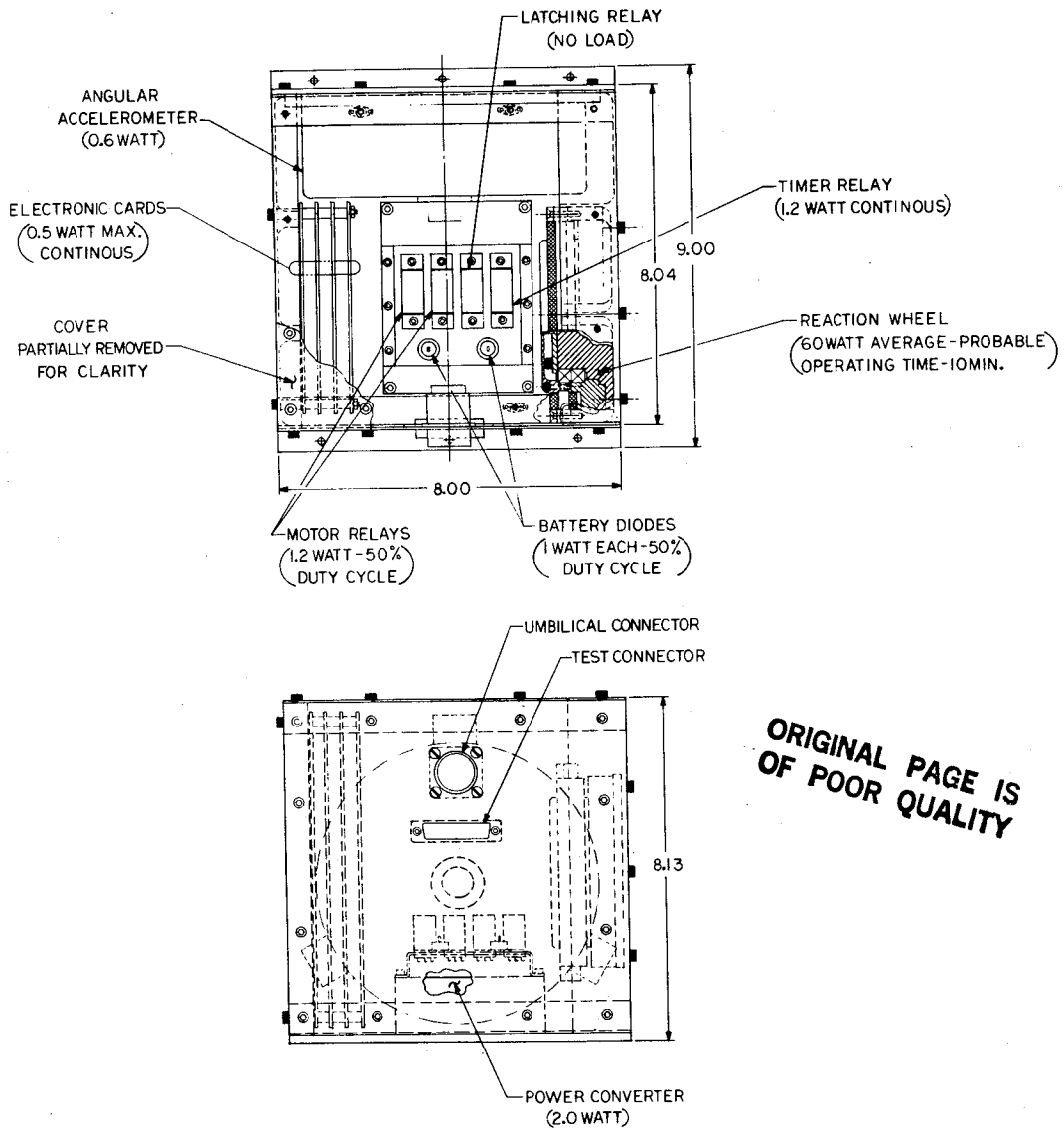

Figure 3. Active Nutation Damper Package
LAGEOS

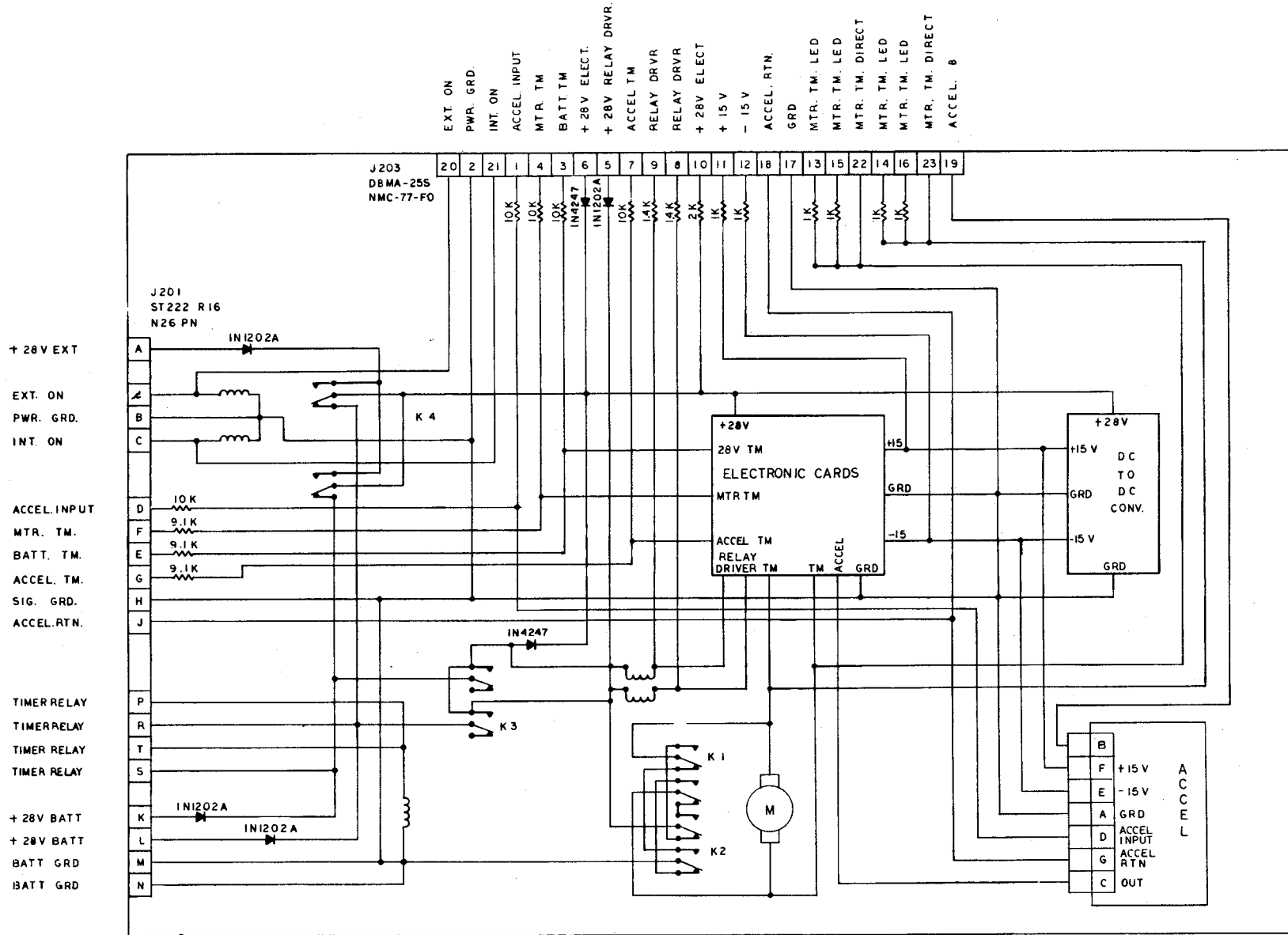

Figure 4. Wiring Diagram of the LAND System

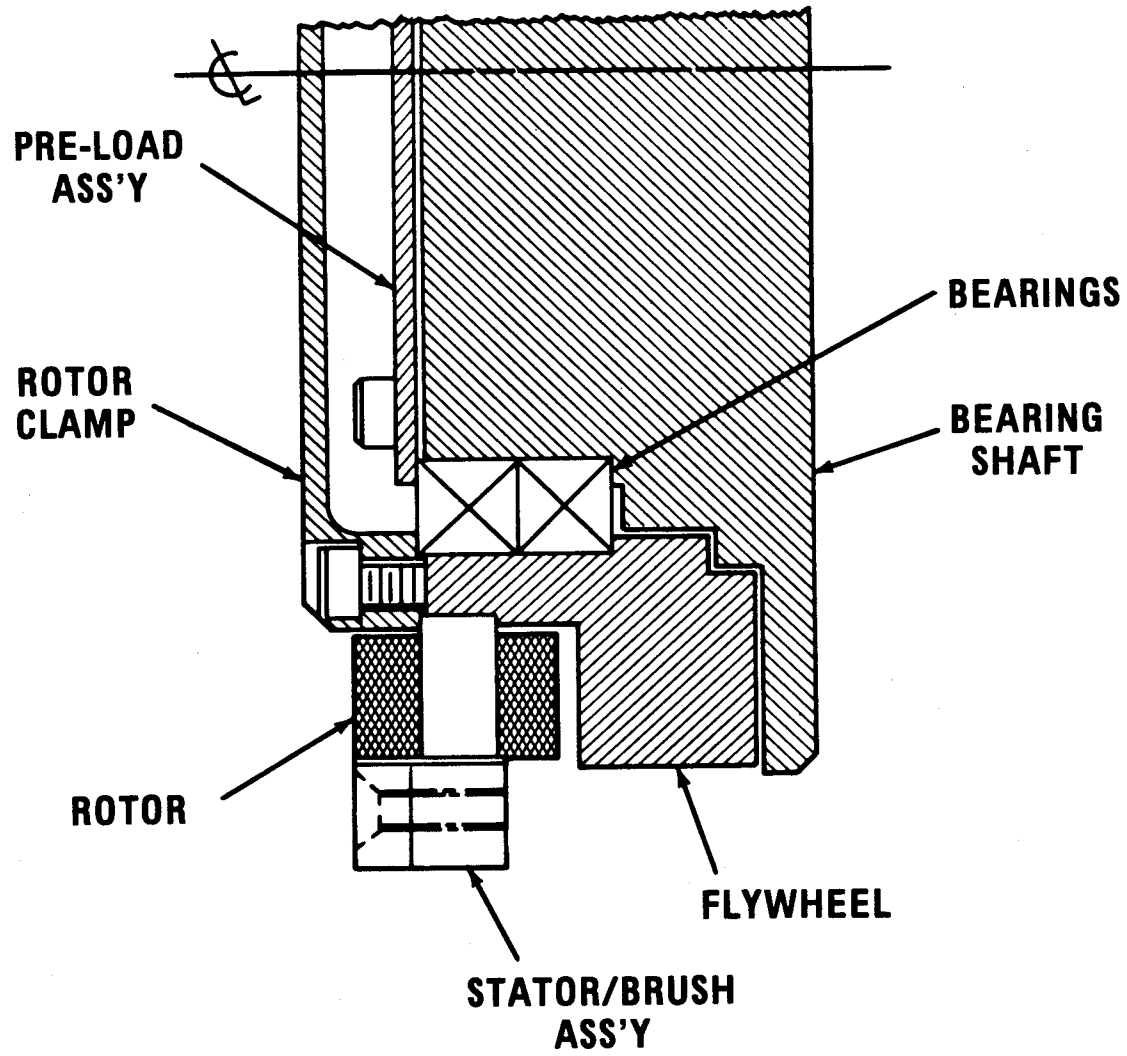

Figure 5. Motor/Bearing Assembly

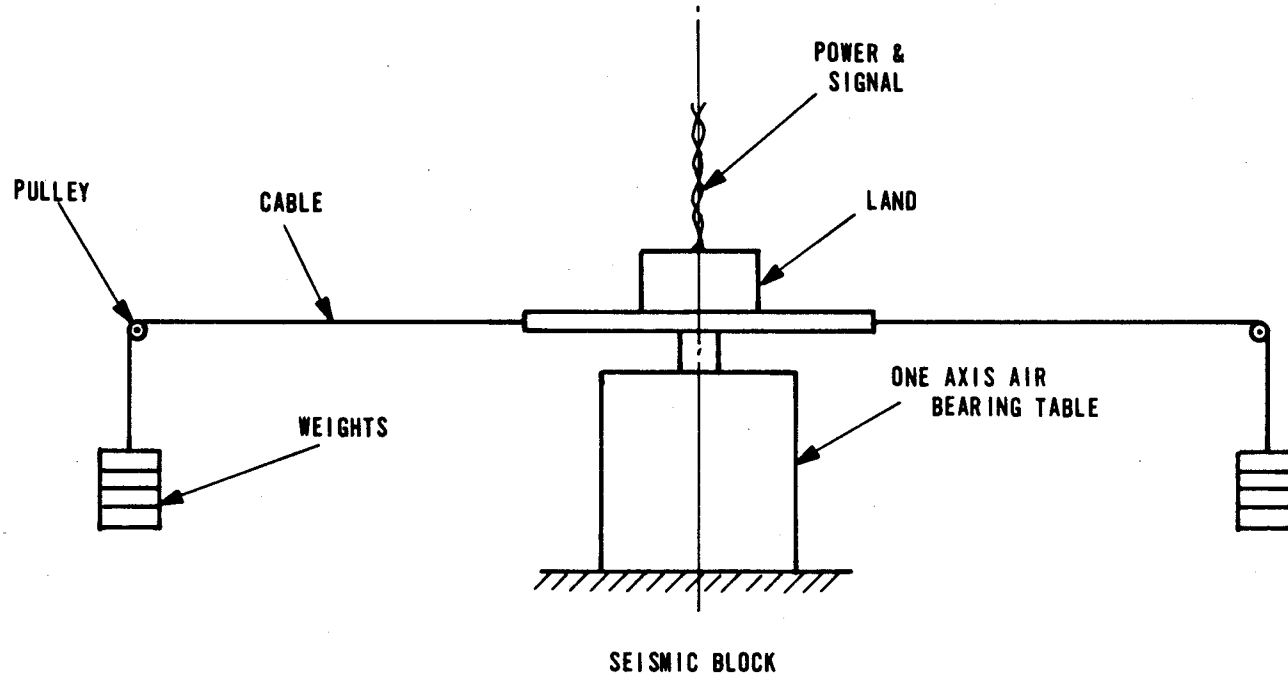

Figure 6. Physical Stimulation Test Setup

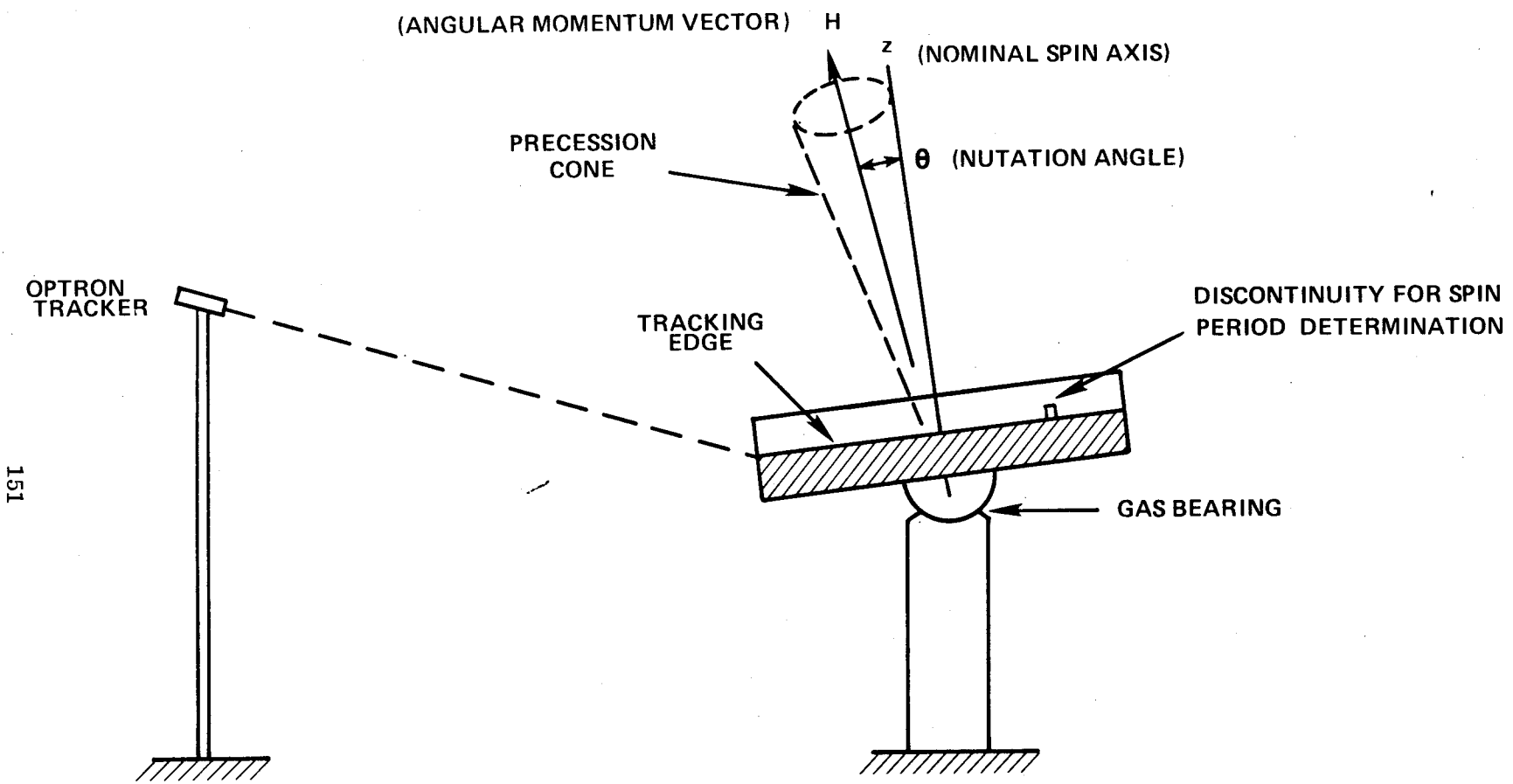

Figure 7. OPTRON Attitude Sensing

