

A TWO AXIS POINTING SYSTEM FOR AN ORBITING ASTRONOMICAL INSTRUMENT

R F Turner - J G Firth

SRC Appleton Laboratory Astrophysics Research Division, Culham Laboratory,
Abingdon, Oxon, OX14 3DB.

A B S T R A C T

The system described has been built for incorporation into a solar flare X-ray instrument due to be orbited as one of a number of instruments on the NASA Solar Maximum Mission (SMM) satellite in late 1979. It enables the instrument to be rotated about 2 mutually perpendicular axes in 5 arcsecond steps within a range of 7 arcminutes, thus giving the instrument the capability to map areas of the sun.

INTRODUCTION

The instrument for which the system was designed is a seven channel Flat Crystal Spectrometer (FCS) (Figure 1), and is the result of a collaboration between the Appleton Laboratory (Astrophysics Research Division, Culham) U.K., Mullard Space Science Laboratory U.K., and Lockheed Missiles and Space Corporation U.S.

Although the spacecraft has the capability to point at a flare region on the solar disc, the multiplicity of instruments on board implies that mapping requirements be met by individual raster systems. Spacecraft constraints in terms of mass and accommodation led us to choose a "flat pack" raster platform for this X-ray instrument. Similarly a constraint upon conduction transfer (virtually all heat generated or absorbed has to be radiated to the spacecraft wall) led to the selection of a low power raster system which could maintain its pointing in the unpowered mode.

It is anticipated that misalignment between instrument and spacecraft due to launch forces could be about 1 arcminute. The operating range of the system is designed to encompass any such misalignment.

Although originally conceived as a modular design, instrument and spacecraft needs (particularly the minimum natural frequency requirement of 45 Hz) caused the raster system to evolve into an integral part of the instrument.

Essentially the raster system consists of a two-axis flex pivot driven by a cam mechanism via an arm. For the purposes of description the system (Figure 2) can be broken down into five areas:

- 1) Two axis pivot
- 2) Raster drive
- 3) Position readout
- 4) Launch locks
- 5) Wiring

TWO AXIS PIVOT SYSTEM

The 5 arcsecond step requirement and the mass of the instrument led us to consider that the vibration environment could lead to problems of brinelling and torque noise with roller bearings, thus the frictionless flex pivot system was selected.

A compact two-axis gimbal platform 9 cm tall was designed around four standard 2.54 cm diameter electron beam welded flex pivots. The arrangement adopted is shown in figure 3. Each axis is formed by a pair of pivots with their inner sleeves clamped in a common yoke. The outer sleeves of the Z axis pair are clamped to the instrument base plate and the outer sleeves of the Y axis pair to the main instrument support structure.

Even though the raster system is latched down for launch it is estimated that the pivot will still carry some 30% of the load. These units can meet this demand and have an inbuilt flexibility which can tolerate structural movements during launch.

Flex pivots can be used up to some 7° without significant centre axis shift so this application requiring only 0.5° rotation is comfortably within the margin.

RASTER DRIVE

The drive part of the system is based upon two separate cam units (one for each axis) with an additional pair fitted for redundancy. These operate on roller followers, flexibly attached to the raster arm (figure 4).

The motors are 200 steps/rev. devices with 2 centre tapped windings driven in single phase mode so that powered and unpowered rotor positions coincide. They are of double ended shaft configuration and were specified with high detent torque to resist angular displacement in the unpowered state.

A cam is fitted to the forward end of each motor and an absolute 200 position/rev. shaft angle encoder to the other. The cam profile is such that 1 motor step will cause the instrument to move by 5 arcseconds. The drive circuitry contains a re-triggerable one-shot multivibrator which ensures that 60 milliseconds after the last clock pulse, power is removed from the motor.

In order to minimise power consumption all circuitry, with the exception of the motor power drivers, was built using CMOS. The power dissipation with no motors running is about 140 mW.

Mechanism

The drive principle is shown in Figure 5. Both drive units (Z and Y) are anchored to the base plate and are so arranged that each drive unit when operating utilises the other as a slide for the raster arm. The principle is that only one axis (Z for example) is active at a given instant. Of each drive unit, one stepping motor remains dormant while the other lifts a second order lever, pivoted at the contact with the dormant cam, to raise or lower the raster arm. The Y unit cam followers are required to ride over the cams but without deflecting the raster arm. This is achieved by opposing the cams so that as one follower rises the other falls, giving a zero net deflection at Y.

The cams are provided with sufficient lift so that should the first motor in any pair fail in the active range, then the other still has the capability to cover the operating region. The followers are kept in contact with the cams by spring force and the raster arm has a built-in adjustment capability to allow correction of tolerance build-up during assembly.

POSITION SENSING

Although the mode of control is step instruction from the on-board computer, three additional systems enable a check to be maintained on the memory accuracy. Together they provide a considerable capability for diagnosis of a system malfunction in orbit.

Shaft Angle Encoders

Each of the raster motors is equipped with a 200 position/rev. absolute encoder. The purpose of these is twofold:-

- (a) To verify that the motor has in fact moved to the location commanded.
- (b) To enable set up in orbit.

The assumption was made that the position of each cam cannot be determined with any certainty after the spacecraft is inserted into orbit. The possible permutations of the four cam positions could be unscrambled from the transducer and/or alignment sensor, given sufficient real time access to spacecraft and data. The far more realistic solution employing a shaft angle encoder on each cam has been utilised, the benefits of which have been noted when setting up even in the laboratory environment.

Position Transducers

Two strain gauge transducers are mounted across the raster platform flex pivots. They are arranged in such a manner that one measures angular movement between the instrument and the baseplate in the Y axis only, and the second detects similar shifts in the Z axis. The output from each

transducer is amplified and fed into an 8 bit Successive Approximation A to D convertor. The convertor output is in Natural Binary code, and the system gain is such that a single step of 5 arcsec causes a change of 1 in the output count.

Solar Sensor

The X-ray instrument is fitted with a solar sensor which can detect limb (edge of the solar disc) crossing to an accuracy of 5 arcseconds. With this information compared to the spacecraft solar pointing co-ordinates we can off-set the instrument to co-align with the spacecraft boresight.

LAUNCH LATCH

The purpose of the latching system is to carry the launch loads and to hold the raster followers clear of the cams. This area more than any other was the subject of on-going design evolution during instrument development. The original pin release system proved to be inadequate in the light of increased instrument mass and substantial finite element structural analysis of the instrument when subjected to the NASA environmental test requirements. The system shown in figure 6 was developed and meets the structural requirements.

The instrument is latched onto the baseplate by four clamps, each of which is held closed by a titanium tie bar. The latches are released by firing a pyrotechnic guillotine which cuts through the bar. The clamp arms are spring loaded so that when the bar is severed, they move apart. As a back-up a second guillotine is installed on each bar but this will not be fired unless the primary fails.

The latch mating surfaces are coated with a thin film of PTFE to reduce the possibility of binding.

WIRING

With light forces and precise positioning of the system, the need to carry some 200 wires across the raster interface can cause problems with harness stiffness and wind up during vibration.

The system evolved in figure 7 has proved most successful. All large bundles were split as shown. Several cables containing 3 or less wires were left intact but the effect of their stiffness was minimised by placing the thickest bundles nearest the pivot. The whole assembly was relaxed in the desired position by heating to $\sim 100^{\circ}\text{C}$.

The flat loop configuration attached at each end to the instrument and to the base plate has been shown to produce insignificant loads and has remained constant throughout environmental testing.

ACKNOWLEDGMENTS

The system described was designed and built with the assistance of our colleagues in the Engineering Group of the Astrophysics Research Division to whom full credit must be given.

Additionally we wish to acknowledge the role played by the consortium's three Principal Investigators, Dr. A. H. Gabriel, Dr. J. L. Culhane and Dr. L. W. Acton in setting the goals and providing constructive comment en route.

TABLE 1

SYSTEM CHARACTERISTICS

Mass of instrument (on raster platform)	100 kg
Raster pattern required	5 x 5 arcmin
Allowance for changes in spacecraft structure	2 x 2 arcmin
Designed scan size (with redundancy)	7 x 7 arcmin
Designed scan size (without redundancy)	28 x 28 arcmin
Single step size	5 arcsec
Accuracy (positioning)	1 step
Step rate (maximum)	32 steps/sec
Peak running power (at 32 steps/sec - fast reposition mode - 2.7 seconds max.).	6.5 watts
Data gathering mode (4 steps/sec)	0.78 watts

TABLE 2

COMPONENT SUMMARY

ITEM	MANUFACTURER	DESCRIPTION
Flex Pivot	Bendix, Utica, N.Y.	2.54 cm dia Electron beam welded.
Transducer	Kistler Morse, Seattle	Strain gauge type
Raster Motor	C. D. C., Los Angeles	Size 15 double ended 200 steps/rev. high detent
Shaft Angle Encoder	Moore Reed, Hungerford, U.K.	200 Step/rev. absolute, contacting
Guillotine	Horex, Holister, Cal.	Special version to cut titanium bar.

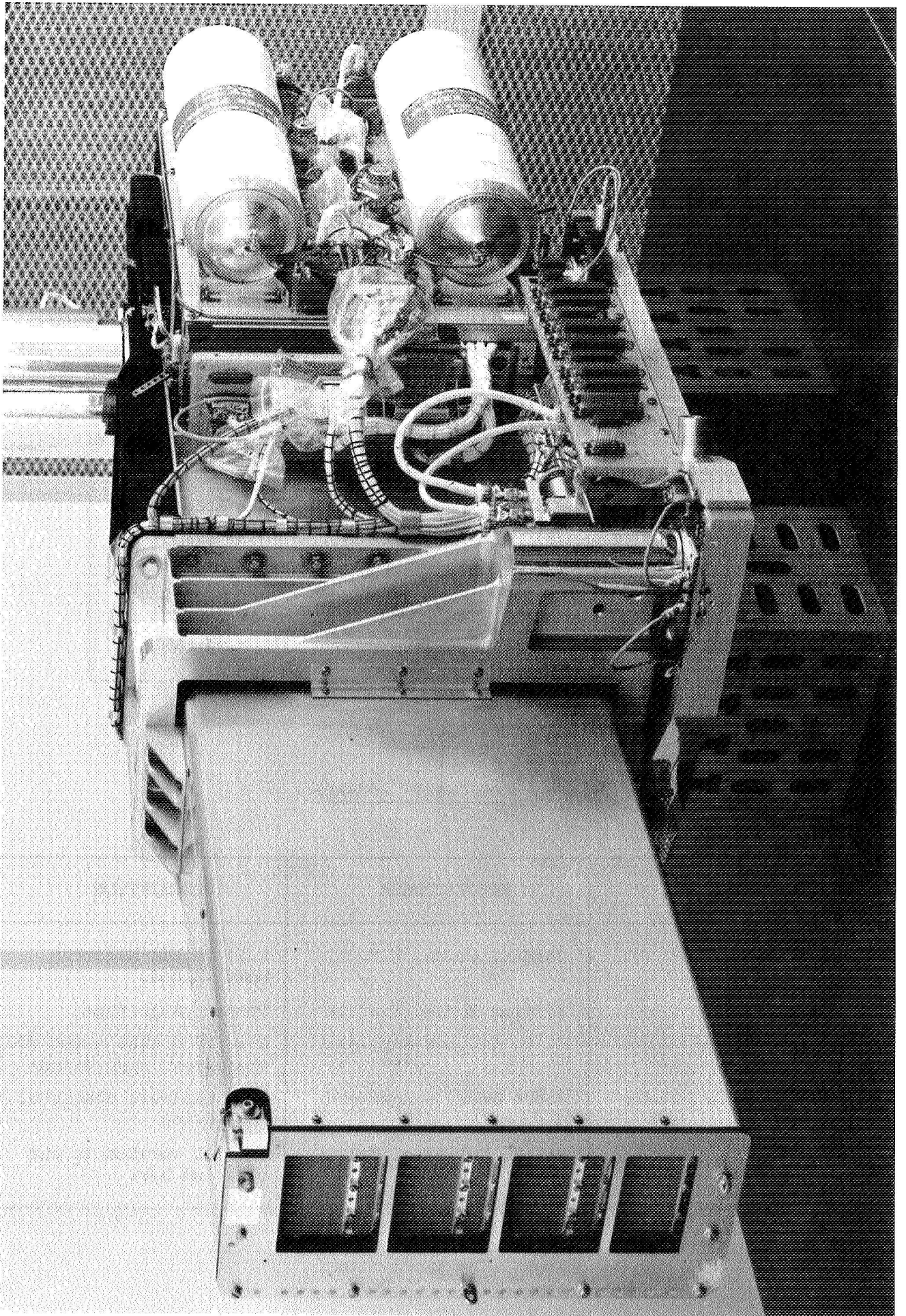

Fig. 1 FCS Instrument

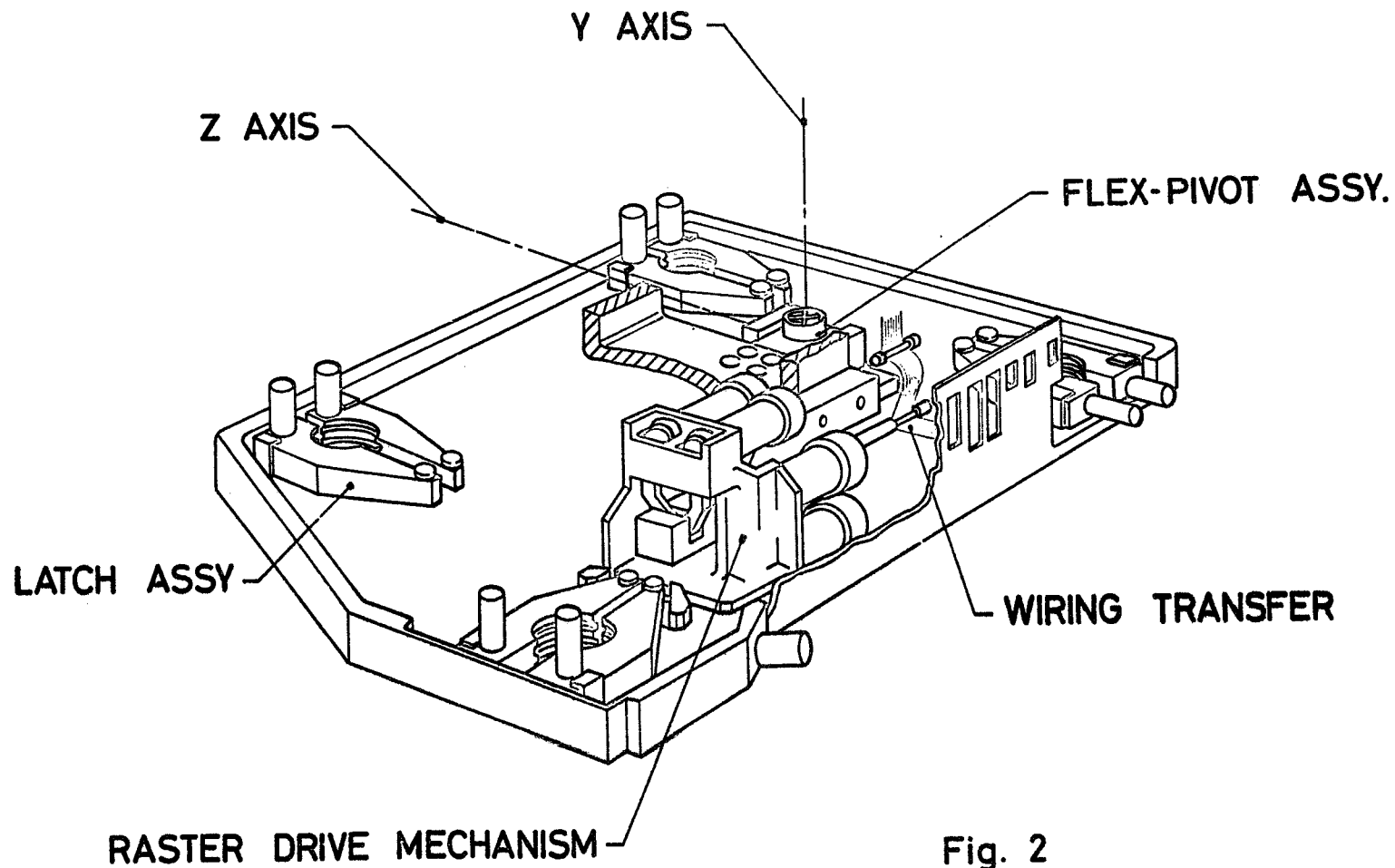

Fig. 2
Raster System

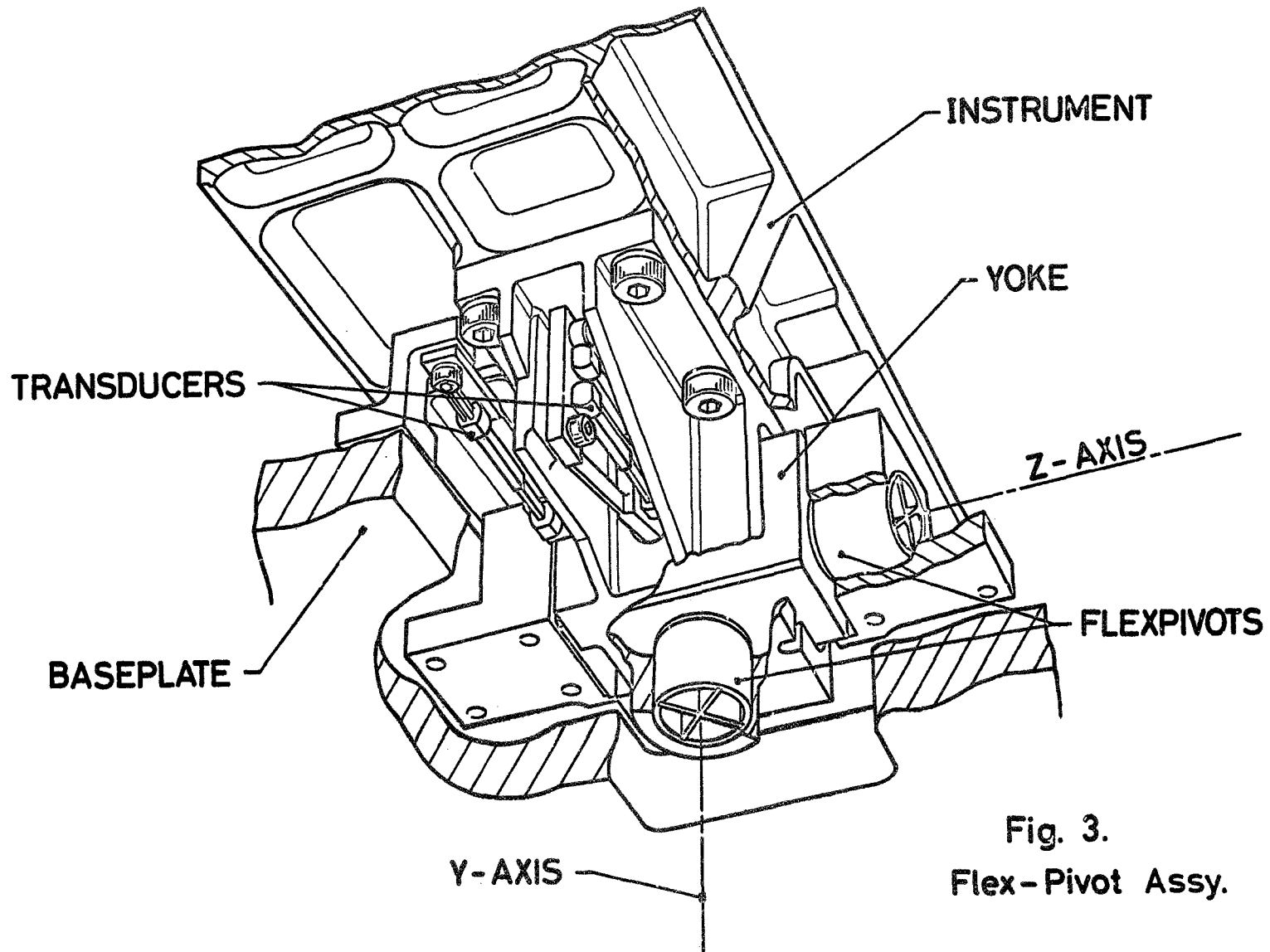

Fig. 3.
Flex-Pivot Assy.

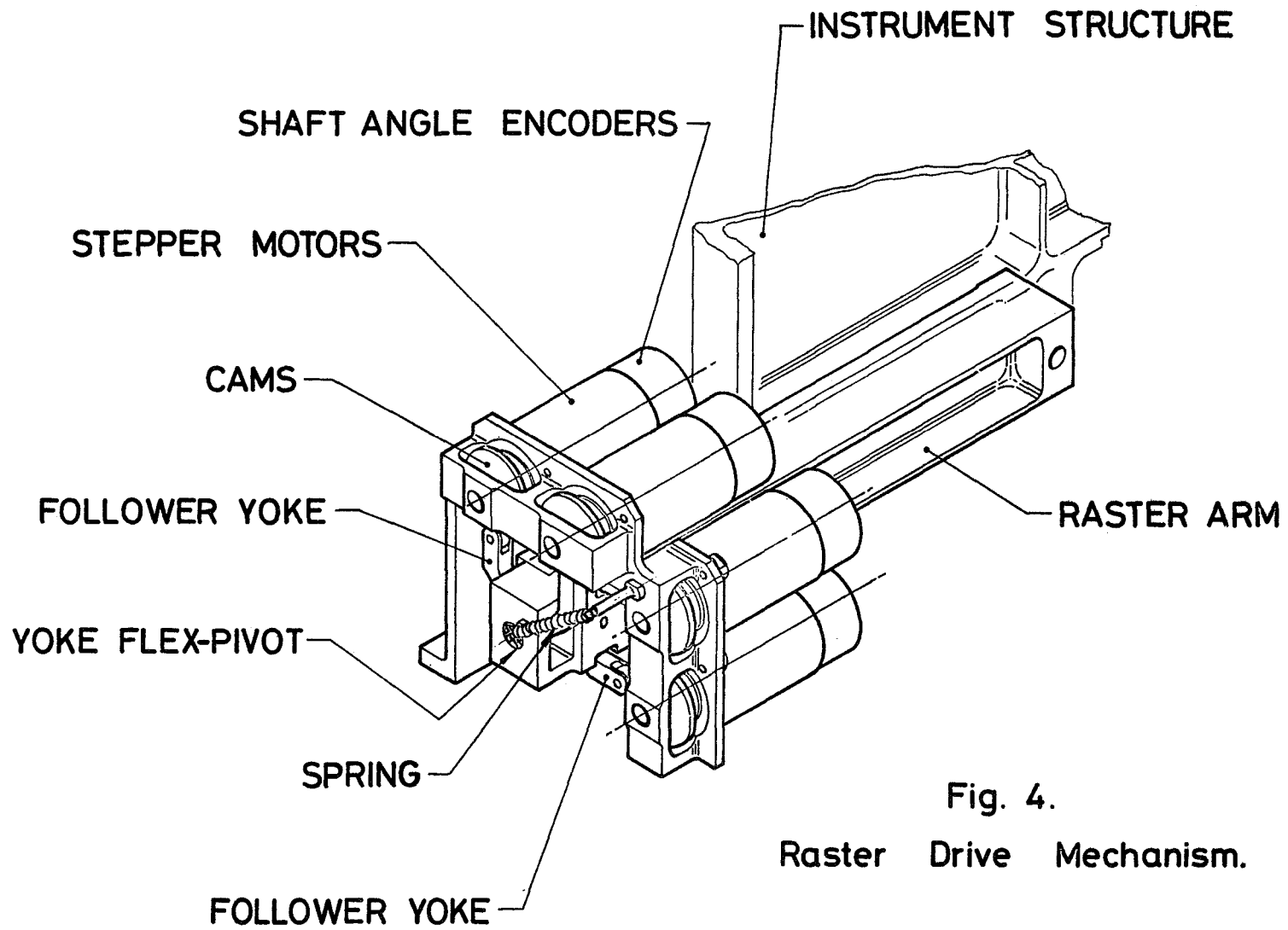
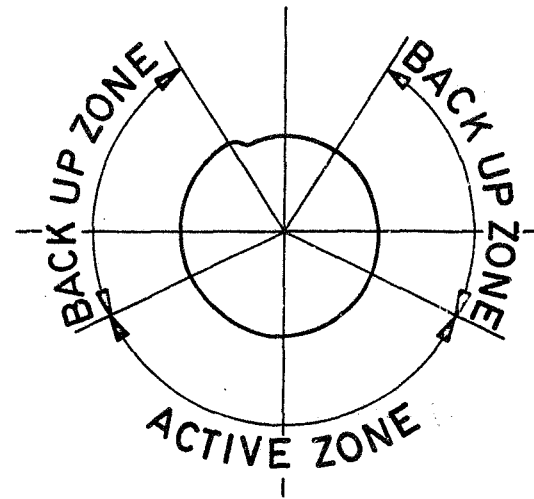
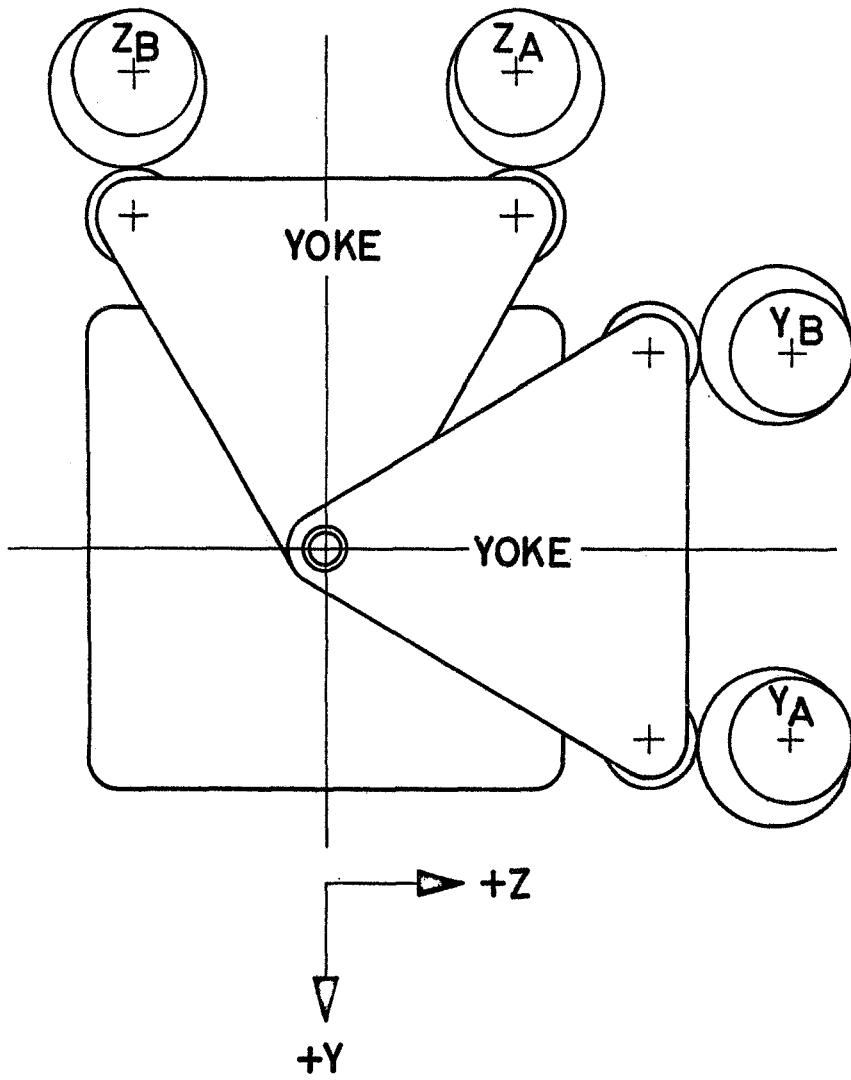

Fig. 4.
Raster Drive Mechanism.



Cam Profile

Fig.5.
Principle of Raster
Mechanism.

37

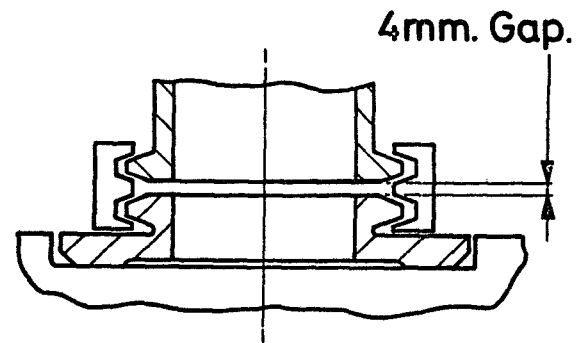
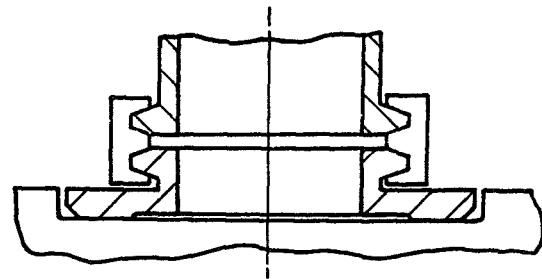
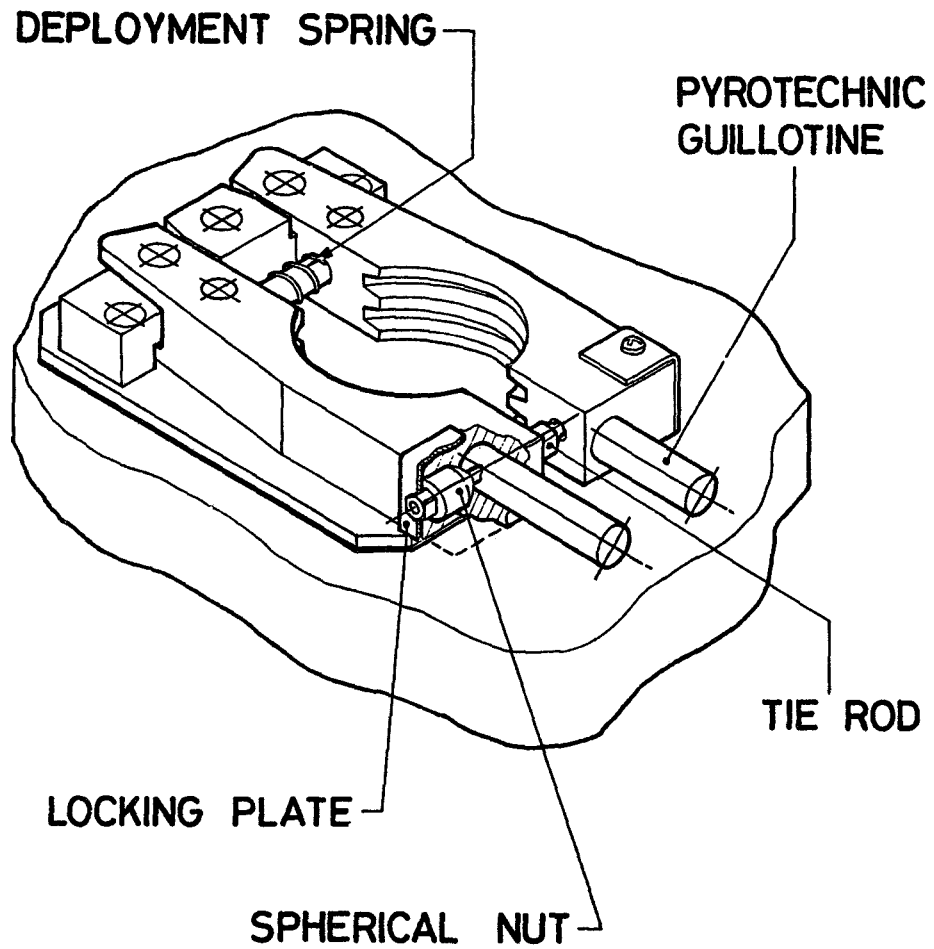

Fig. 6.
Launch Latch.

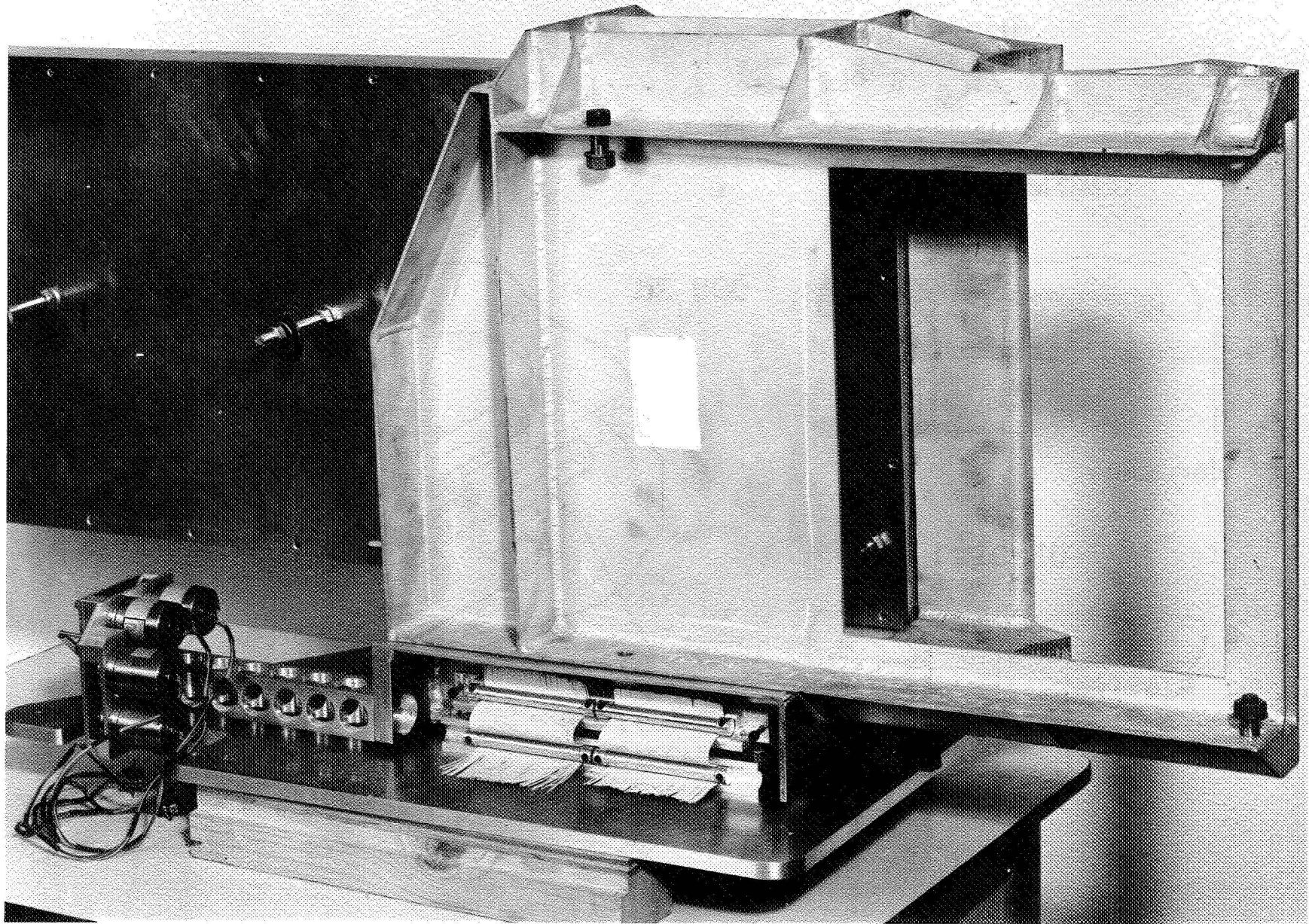

Fig. 7 Wiring Detail