

# DEVELOPMENT OF THE TRIDENT I AERODYNAMIC SPIKE MECHANISM

By Mark D. Waterman and B. J. Richter

Lockheed Missiles and Space Company

## ABSTRACT

The Aerospike drag reduction mechanism was designed and developed for use on the Trident I submarine launched ballistic missile. This mechanism encounters a unique combination of environments necessitating unique design solutions to ensure satisfactory operation over its design life. This paper traces the development of the Aerospike emphasizing the unique and interesting problems encountered and their solutions.

## INTRODUCTION

The Aerodynamic Spike (Aerospike) is a deployable drag reducing mechanism stowed within the nose fairing of the Trident I submarine launched ballistic missile. This mechanism maximizes missile performance within the limited envelope available by transforming the aerodynamic characteristics of a blunt, space efficient nose fairing into a more streamlined shape.

The Aerospike mechanism is comprised of three subsystems which perform three separate and distinct functions: The mechanical inertial initiator ( $I^2$ ) discriminates the correct missile flight acceleration and initiates a gas generator; the gas generator provides the energy for deployment, and boom segments which once deployed and locked, establish a region of separated flow which provides the induced drag reduction. The Aerospike is required to be maintenance- and service-free over a ten year design life. Initiation and Deployment of the Aerospike occurs just after the missile is launched; after the missile leaves the atmosphere the Aerospike is jettisoned along with the nose fairing approximately 2 minutes after missile launch. The major components of the Aerospike are shown in Figure 1.

The Aerospike is now in production after a four year development program culminated by eighteen consecutive successful flight tests.

## ACCELERATION SENSING

The first task of the Aerospike is to detect the correct flight acceleration profile and to ignite the gas generator at the proper time. An all-mechanical approach was selected for this function as the Aerospike is completely isolated from the missile electrical system due to its position in the nose fairing, which is subject to numerous installation cycles. The inertial initiator must also remain safe when subjected to a variety of transportation/handling environments of short term acceleration, vibration,

shock, and temperature/humidity extremes as well as the long term low level vibration encountered in the submarine launch tube. The inertial initiator must possess good aging characteristics as it is not tested or serviced once it is installed in the Aerospike; it must be flight ready over its 10 year design life.

The components of the inertial initiator are shown in Figure 2. A spring mass system senses missile acceleration and releases a timer once the correct acceleration level has been reached. Torque generated by a watch-like mainspring drives a timer escapement. After the correct time interval has been achieved, a spring-driven firing pin is released to ignite the gas generator. If the acceleration is removed before firing pin release, the unit will reset in less than one second. Figure 3 delineates the "must fire" regime of the inertial initiator; the inertial initiator will not fire when subjected to any acceleration outside of the "must fire" environment.

Correct operation of this mechanism is ensured by a series of in-process tests and a final acceptance test in which the "must fire" and "no fire" limit are checked. During development testing it was discovered that the unit would cease to operate properly after only three months of storage. The problem was traced to the lubrication system used and to the low design torque in the mainspring. Various design changes were incorporated to increase the torque margin of the I<sup>2</sup> so that the unit was much less susceptible to friction variations, and a change in the lubrication method was made.

The lubrication system originally used was a combination of the MIL-L-6085 oil for the linear and ball bearings, a dry film lubricant on the timer, and a combination of dry film lubricant and grease for the firing pin release mechanism. Examination of the aged units revealed that this system was unacceptable, mainly due to oil migration which made the unit susceptible to contamination and interaction of the oil and dry film lubricant. The dry film lubricant used in the timer also was a problem due to process variations and the extremely tight tolerances of the timer gears.

The aging problem was solved by reducing the amount of oil to a minimum by centrifuging the bearings, elimination of the grease on the firing pin release mechanism, and a change in the timer lubrication to a Lockheed Missiles & Space Co. (LMSC) developed process of applying dry moly disulfide powder to the part to be lubricated (Molykote Z). This method was chosen after testing showed it to be superior in terms of friction reduction, aging, and ability to withstand repetitive cycling (service life). Table 1 shows the results of the test. No inertial initiator timing anomalies have occurred in the two years after the new lubrication system was incorporated.

Table 1. Inertial initiator timer lubrication evaluation

Lubricant	Friction	Aging	Service Life
Dry Film			
o Everlube 620C	Low	Moderate	Moderate
o Electrofilm 77S	Low	Moderate	Good
No Lubrication	High	Good	Poor
Molykote Z	Low	Good	Good

## DEPLOYMENT

The Aerospike is deployed shortly after the missile has reached a sustained acceleration and the deploying boom sections are subjected to a combination of aerodynamic loads, acceleration, and vibratory loadings; in addition to deploying under these flight loads, the Aerospike is ground tested on a centrifuge which imparts a large side load due to coriolis effects. Once deployed, the Aerospike must meet stringent dimensional and structural requirements.

Deployment is accomplished by internal pressures created by the solid propellant gas generator, which acts on the tube sections to overcome static and dynamic friction and external environments. The momentum and forces imparted by the gas force the joint/locking mechanism into the engaged position. Gas pressure initially builds up rapidly until a set of retention bolts fracture, releasing the tube sections. As the tube sections begin moving, the rapidly expanding volume within the Aerospike causes the pressure to decay; after the Aerospike is fully extended, the gas generator continues to build up pressure to ensure that all joints are in the locked position. Under large external loadings the deployment process is slowed sufficiently to require joint engagement due to internal pressure forces alone. Two related problems occurred during early deployment testing: Under ground test conditions the deployment was taking place too rapidly, causing joint structural damage and rebound, and the gas generator was extinguished by impact induced acoustic resonance. These two problems were solved by a complete redesign of the gas generator and modifications to the joint/locking mechanism.

The gas generator extinguishment problem was especially perplexing because the N-5 propellant is used throughout the industry (2.75 inch rocket) and was thought to be well characterized; additionally, the extinguishment phenomena was temperature related, occurring only at low ambient temperatures. The extinguishment problem was traced to acoustic resonances induced by the shocks produced by the joints impacting into place. This resonance caused pressure excursions outside the region of stable burning and extinguishments occurred. Although extinguishment occurred before final extension, the tube sections had sufficient momentum to complete the deployment. Two methods of solutions were pursued: The first was to alleviate the impact shocks through addition of an energy absorbing device in each joint, or to slow down the deployment by reducing gas generator flow rate. The second method was to mechanically break up the resonance in the gas generator through grain design and resonance rods.

Although a number of solutions could eliminate the extinguishment, complete elimination of the pressure fluctuations at joint impact could not be achieved and it was decided that the N-5 propellant was unsuited to this application. A low metalized propellant, Arcite 386 M with 2% aluminum for resonance suppression, was selected and the grain geometry was tailored to deploy the Aerospike more slowly thereby reducing the shock induced resonance as well as the related joint impact damage.

The second major problem was that the deployment was too rapid, causing damage to the joint/locking mechanism and rebound past the locking area. The most severe damage occurred at the innermost joint which is the last joint to impact and carries the greatest kinetic energy; internal gas pressure was insufficient to re-engage the lock mechanism on this joint which has the smallest cross sectional area for the gas to react against. The solution to this problem took three forms; the strength of the joint/locking

mechanism was increased to provide more resistance to impact damage and the locking finger strength was increased to reduce the chances of rebound. The deployment was slowed by decreasing the initial gas generator flow rate and reducing the strength of the retention bolts by 50%, and, finally, the propellant loading was increased by 70% to increase peak pressure to ensure pressure lockup.

Incorporation of the gas generator and the modifications have proven completely successful in solving the deployment problems. Aerospikes have since been tested under a large variety of conditions ranging from static ground tests to missile flight test without an anomaly. Figure 4 compares the two deployments and Table 2 gives a history of Aerospike deployments.

Table 2. Aerospike deployment

Test #	Deploy Time, ms	Peak Velocity in/sec	Peak Pressure psi	Joint Lock
1	75	-	240	No
2	82	-	175	No
3	92	960	177	No
4	138	560	470	Yes
5	118	695	500	Yes
6	135	540	575	Yes
7	136	550	550	Yes
8	137	-	500	Yes
9	123	-	500	Yes
10	120	-	-	Yes
11	138	-	-	Yes
12-18	-	-	-	Yes

Note: 1. Changes introduced at Test 4  
 2. Tests 12-18 were flight tests

## STRUCTURAL

The Aerospike becomes a part of the missile structure after it has been deployed and locked and it is subjected to severe environments during powered missile flight. The primary requirement for the Aerospike is to maintain a first bending mode frequency of 25 Hz to assure overall missile stability. During its two minutes of operation, the Aerospike is subjected to a combination of aerodynamic heating loads that raise parts of the aerospike above 1000°F, compressive axial aerodynamic loads of up to 2300 pounds, and vibratory loads that results in tip accelerations of up to 60 G in the first lateral bending mode.

The Aerospike carries these loads through its joint/locking mechanism as shown in Figure 5. This mechanism, the primary determinant of natural frequency, carries the lateral bending loads through the two interference lands (this loading mechanism has been described in a previous paper, "Structural Evaluation of Deployable Aerodynamic Spike Booms," by B. J. Richter, 9th Aerospace Mechanisms Symposium), while the locking fingers provide the required axial strength. These fingers had to be redesigned after an early test revealed a design deficiency. The locking fingers were fastened to the tube section by pins; the early design had only one pin for every four lock fingers which allowed the fingers to rotate about the retaining pins and slip out of the lock groove. By doubling the number of pins, this rotation was minimized and the axial capability was doubled to about 16,000 pounds - more than five times the flight requirement. Other changes, detailed in Figure 5, also helped increase the axial capability and provided additional capability to withstand the deployment shock and subsequent rebound.

The Aerospike posed a challenge in testing the structural capability because each of the major environments - heat, vibration, and axial loads - affects the natural frequency and axial strength of the Aerospike, the prime determinants of Aerospike acceptability. A combined environments test was devised to apply simultaneously simulated flight loads to the Aerospike. A shaker is used to apply a simultaneous combination of sine and random vibration, radiant heat lamps provide simulated aerodynamic heating, and an air cylinder/cable arrangement applies the simulated aerodynamic compressive load. The Aerospike is subjected to vibration in both the axial and lateral directions, although not simultaneously. Figure 6 shows the results of a typical lateral combined environments test; natural frequency can be seen to decrease as both the vibration level is increased and the skin temperature increases. Data from wind tunnel tests and two instrumented flight tests have shown the combined environments test to be a reasonable simulation of flight environments and the Aerospike has been proven to have structural capability far exceeding its flight loadings due to being designed for natural frequency and heat loadings at the end of flight.

#### CONCLUDING REMARKS

The Aerospike has proven to be an extremely successful method of improving the range of the Trident I at minimum cost. The unique nature of the Aerospike highlighted the importance of overall system design in mechanisms of this type.

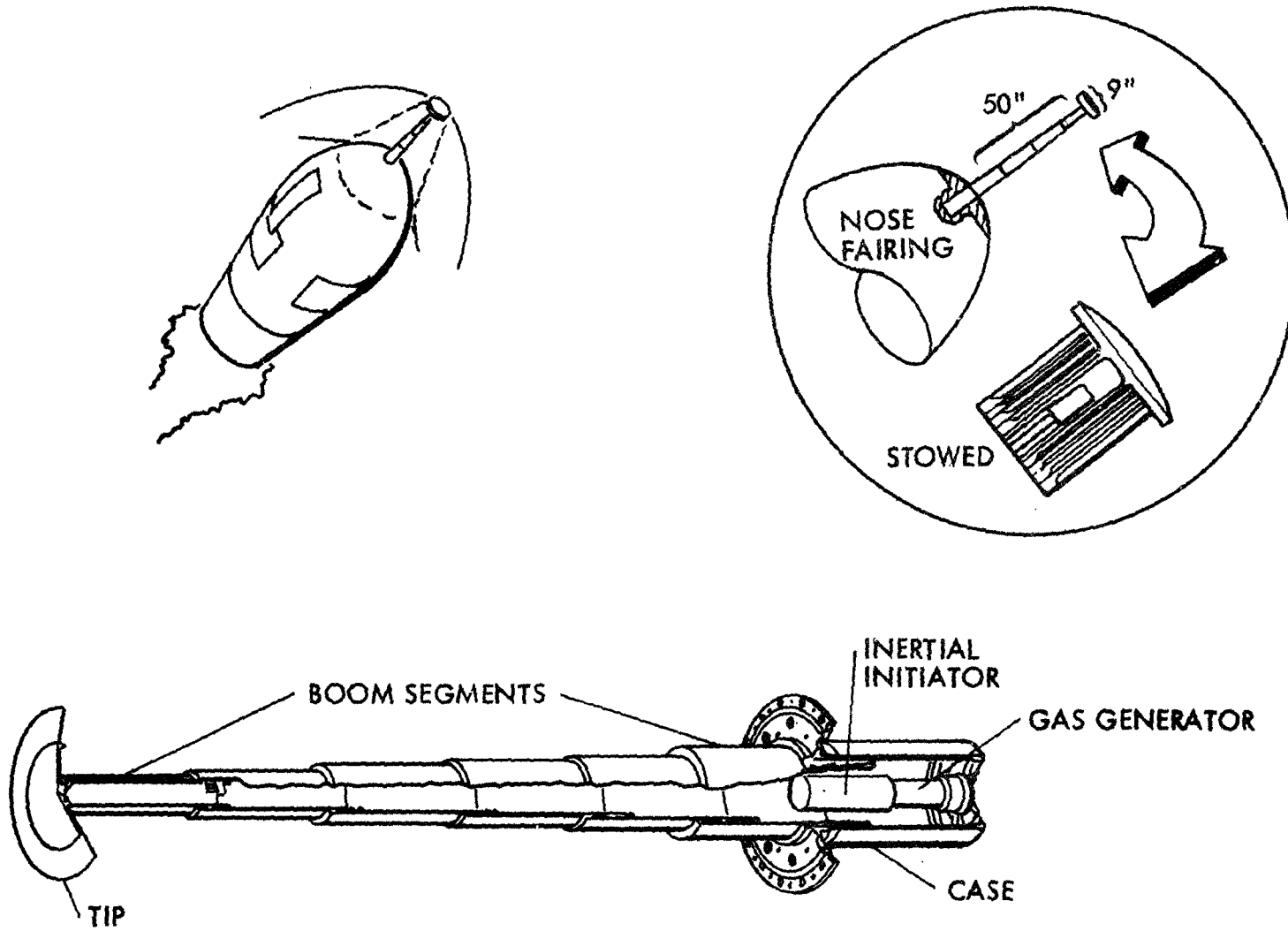

Figure 1 TRIDENT I Aerodynamic Spike

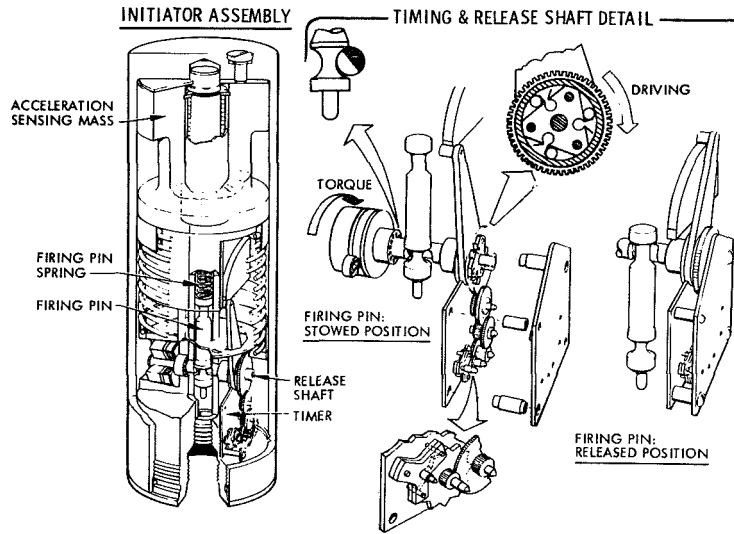

Figure 2 Aerospike Inertial Initiator

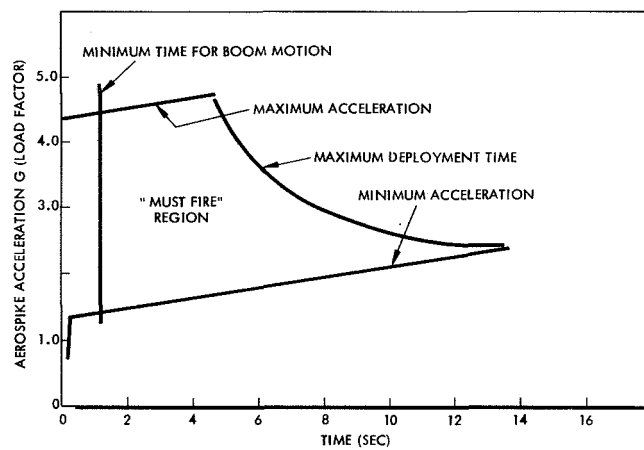

Figure 3 Aerospike Acceleration Initiation and Deployment Requirement

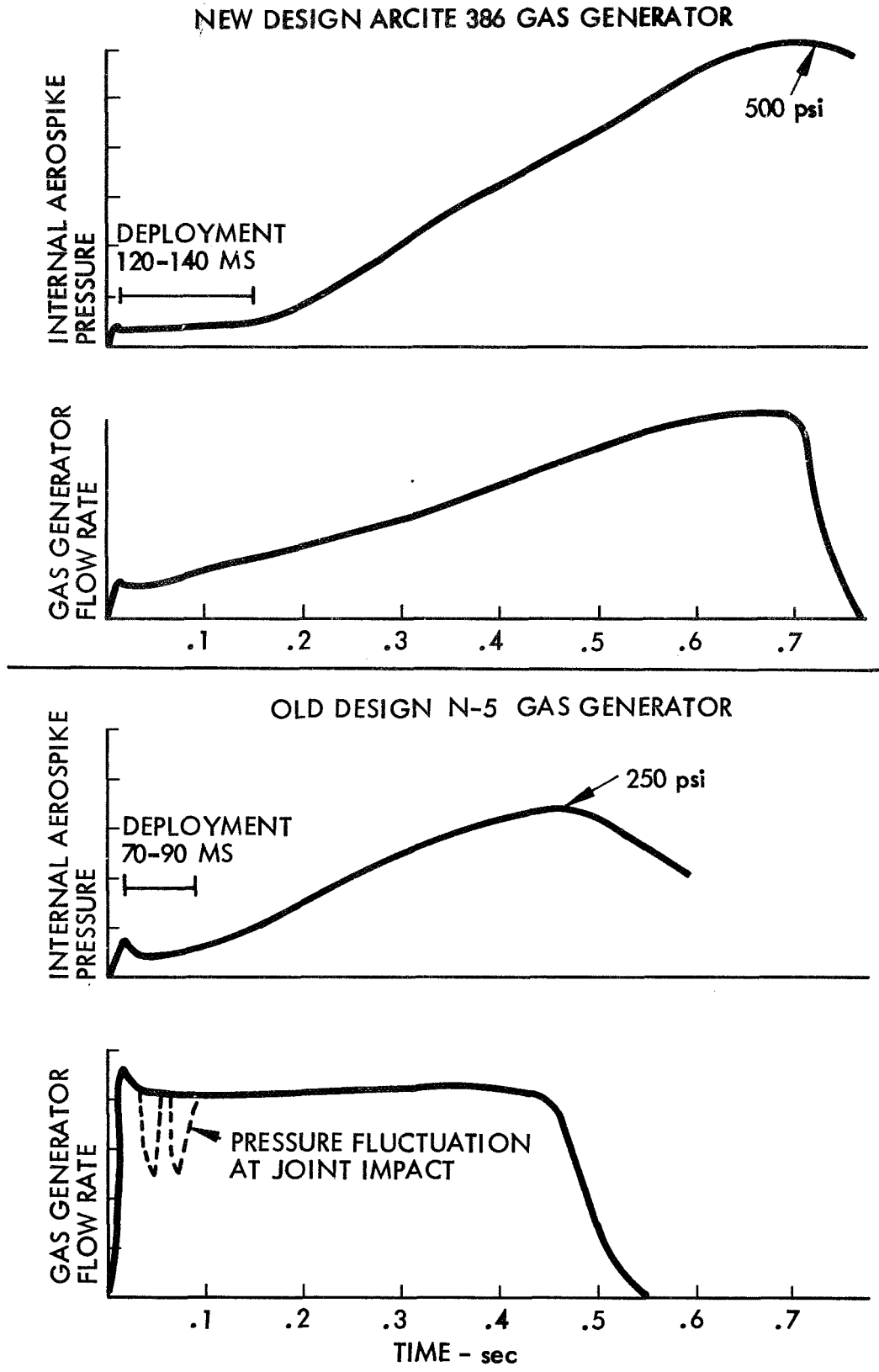
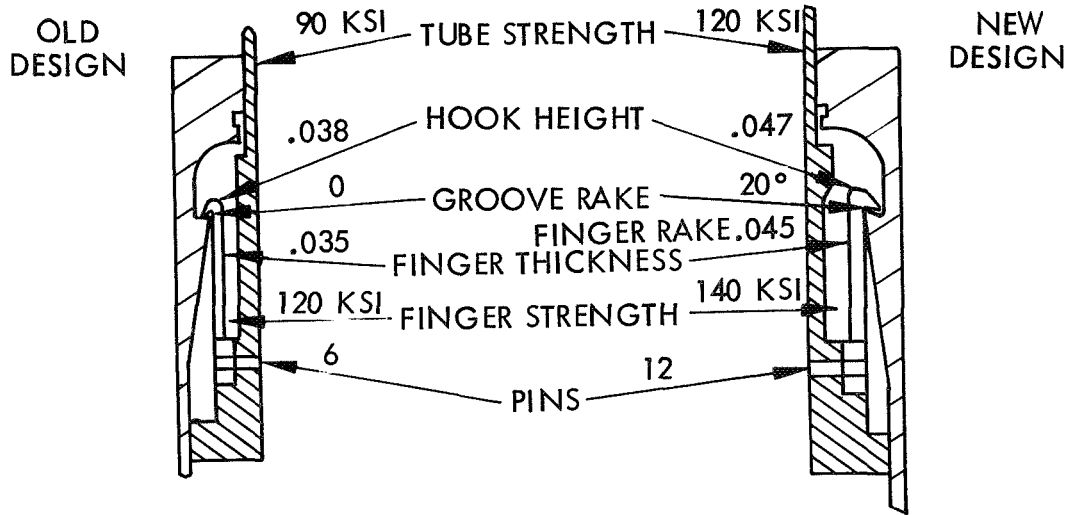

Figure 4 Aerospike Deployment





Joint/Lock Design Improvements

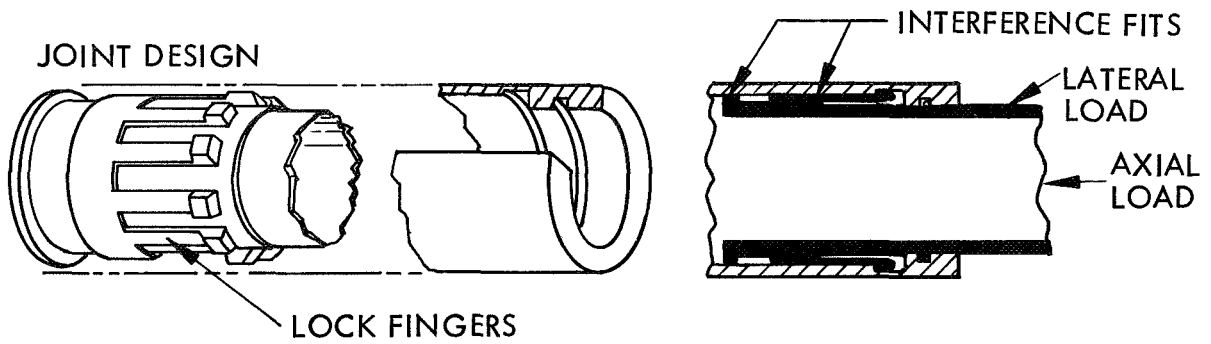

Figure 5 Joint/Lock Mechanism

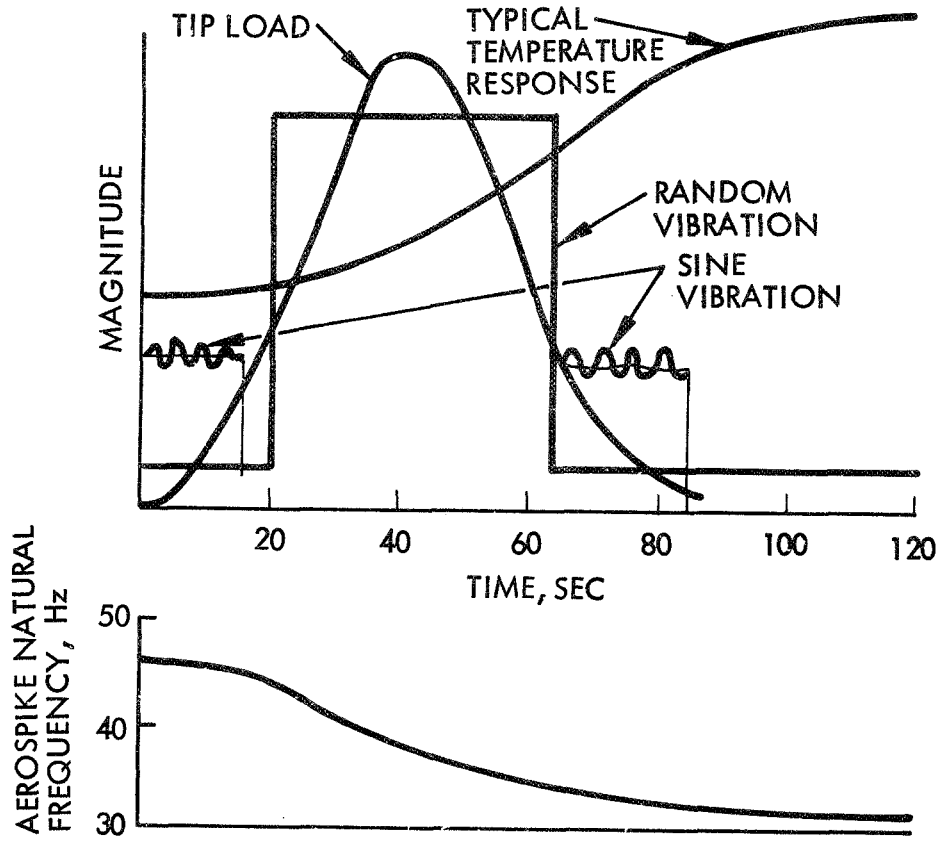
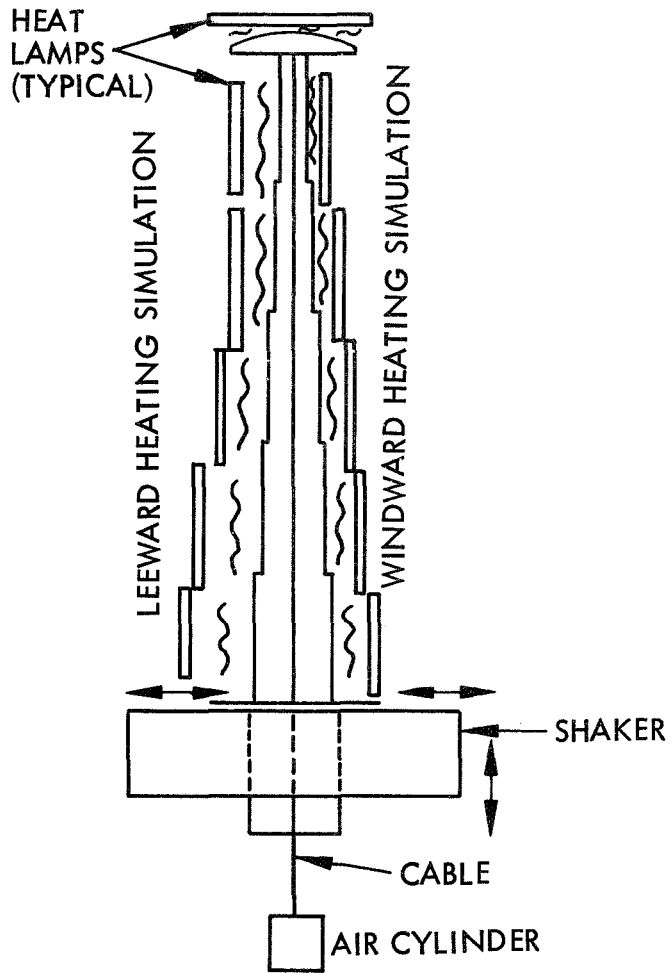

Figure 6 Aerospike Combined Environments Test