



VARIABLE CYCLE ENGINE TECHNOLOGY PROGRAM

PLANNING AND DEFINITION STUDY FINAL REPORT

(NASA-CR-159539) VARIABLE CYCLE ENGINE	N79-23084
TECHNOLOGY PROGRAM PLANNING AND DEFINITION	
STUDY Final Report (Pratt and Whitney	
Aircraft Group) 89 p HC A05/MF A01 CSCL 21E	Unclas
	G3/07 20827

by

J. S. Westmoreland and A. M. Stern

Commercial Products Division
Pratt & Whitney Aircraft Group
United Technologies Corporation

Prepared for

NATIONAL AERONAUTICS AND SPACE ADMINISTRATION
Lewis Research Center

Under
Contract NAS3-20811



TABLE OF CONTENTS

	Page
SECTION 1.0 SUMMARY	1
SECTION 2.0 INTRODUCTION	3
SECTION 3.0 RESULTS OF STUDY – SYNOPSIS	4
3.1 Cycle Selection	4
3.2 Critical Technologies and Component Programs	5
3.3 Demonstrator Approaches	7
3.4 Program Plans	9
3.5 Flight Testing	12
SECTION 4.0 DISCUSSION OF RESULTS	13
4.1 Cycle Selection	13
4.1.1 Introduction	13
4.1.2 Variable Stream Control Engine (VSCE)	13
4.1.3 Inverted Flow Engine (IFE)	14
4.2 Critical Technologies and Component Programs	16
4.2.1 Introduction	16
4.2.2 Variable Geometry Exhaust Nozzle and Installation Technology	17
4.2.3 Duct Burner Technology	20
4.2.4 High Temperature Validation	22
4.2.4.1 High Temperature Validation – Turbine	24
4.2.4.2 High Temperature Validation – Main Combustor	30
4.2.5 Variable Geometry Turbomachinery Technology	32
4.2.6 Integrated Electronic Control Technology	35
4.2.7 Flow Inverter Technology	38
4.2.8 Test Facilities	39
4.3 Demonstrator Configuration Definition	39
4.3.1 Introduction	39
4.3.2 Configuration Screening	40
4.3.3 Description of Candidate Configurations	41
4.3.3.1 New Advanced-Technology Demonstrator Engine	41
4.3.3.2 F100 Core Demonstrator Engine	42
4.3.3.3 ATEGG Core Demonstrator Engine	44
4.3.3.4 EEE Core Demonstrator Engine	46
4.3.4 Predicted Performance	48
4.3.4.1 Engine Performance and Fuel Consumption Trends	48

TABLE OF CONTENTS (Cont'd)

	Page
4.3.4.2 Exhaust Emissions Prediction	52
4.3.4.3 Noise Prediction	56
4.3.5 Installation Analysis	57
4.3.6 Selected Demonstrator Engine Configurations	60
4.4 Variable Cycle Engine Technology (VCET) Programs	60
4.4.1 Introduction	60
4.4.2 Definition of VCET Programs	61
4.4.3 Program Plans	63
4.4.3.1 High Temperature Validation Program (A.1)	63
4.4.3.2 New Advanced-Technology Engine Demonstrator Programs	64
4.4.3.3 Programs for ATEGG-Based Demonstrator Vehicles	70
4.4.3.4 F100 Core Demonstrator Engine Program	73
4.4.3.5 Reduced Cost Demonstrator Programs	73
4.4.3.6 Follow-On Test Options	76
SECTION 5.0 CONCLUDING REMARKS	79

LIST OF ILLUSTRATIONS

Figure No.	Title	Page
3.1-1	Conceptual Configuration of VSCE (Top) and IFE (Bottom)	4
3.4-1	VCET Programs	9
4.1-1	Cross Sectional View of Variable Stream Control Engine	14
4.1-2	Potential Improvements of VSCE Over First-Generation Supersonic Transport Engines	15
4.1-3	Cross Section View of Inverted Flow Engine	15
4.2-1	Exhaust Nozzle and Installation Technologies	18
4.2-2	VCE Testbed Configuration	19
4.2-3	VCE Duct Burner Technologies	21
4.2-4	Project Hot Section Temperature	23
4.2-5	Turbine Cooling Air Turbine	23
4.2-6	High-Pressure Turbine Blade Stress at Critical Operating Points	24
4.2-7	Importance of High Temperature Technology on Engine Performance	24
4.2-8	Turbine Technologies	25
4.2-9	Main Combustor Technologies	30
4.2-10	Typical VSCE Fan Map	32
4.2-11	Fan and Compressor Technologies	33
4.2-12	Controls Technologies	36
4.3-1	Preliminary Definition of VSCE-502B Demonstrator Engine	41
4.3-2	F100-PW-100 Engine Cross Section	42
4.3-3	F100 High-Pressure Compressor Match	42
4.3-4	Demonstrator Engine Concept	43

LIST OF ILLUSTRATIONS (Cont'd)

Figure No.	Title	Page
4.3-5	Scaled Elevation of Low-Pressure Spool Components With F100 Core	44
4.3-6	ATEGG High-Pressure Compressor Match	44
4.3-7	Demonstrator Engine Cross Section	45
4.3-8	Demonstrator With ATEGG Core	45
4.3-9	Demonstrator Engine Cross Section	46
4.3-10	EEE High-Pressure Compressor Match	47
4.3-11	Preliminary Definition With EEE Core	48
4.3-12	Off-Design Inlet Airflow Schedule	50
4.3-13	Fuel Consumption Trends for Supersonic Cruise	51
4.3-14	Fuel Consumption Trends for Subsonic Cruise	52
4.3-15	Updated VSCE-502B Exhaust Emissions Estimates	54
4.3-16	VCE-502B Sideline Noise Update	56
4.3-17	Nacelle and Installation Requirements for a VCE	58
4.3-18	Boeing VSCE Installation	58
4.3-19	Douglas VSCE Installation	59
4.3-20	Lockheed VSCE Installation	59
4.3-21	Subscale Demonstrator Packaging Arrangement	59
4.4-1	VCEE Program Network	62
4.4-2	High Temperature Validation Program (A.1)	63
4.4-3	VCET Programs Based on All New Advanced Technology Hardware	65
4.4-4	Core Technology Program (B.1)	65

LIST OF ILLUSTRATIONS (Cont'd)

Figure No.	Title	Page
4.4-5	Demonstrator Engine Program (C.1)	67
4.4-6	Technology Readiness Program (D.1) Schedule	69
4.4-7	VCET Programs Based on ATEGG Technology	70
4.4-8	Core Technology Program (B.2) Schedule	71
4.4-9	Engine Demonstrator Program (C.2) Schedule	72
4.4-10	Engine Demonstrator Program (C.3) Schedule	74
4.4-11	Engine Demonstrator Program (C.4) Schedule	75
4.4-12	Reduced Cost Demonstrator Program (E.1) Schedule	76
4.4-13	Reduced Cost Demonstrator Program (E.2) Schedule	77

List of Abbreviations

APSI	Advanced Propulsion Subsystem Integration
AST	Advanced Supersonic Technology
ATEGG	Advanced Turbine Engine Gas Generator
BPR	Bypass Ratio
CET	Combustor Exit Temperature
CIAP	Climatic Impact Assessment Program
CO	Carbon Monoxide
C_x	Velocity Axial Direction
dB	decibel
DEEC	Digital Electronic Engine Control
EEE	Energy Efficient Engine
ECCP	Experimental Clean Combustor Program
EGV	Exit Guide Vane
EPAP	Environmental Protection Agency Parameter
EPCS	Electronic Propulsion Control System
EPNL	Effective Perceived Noise Level
FADEC	Full Authority Digital Electronic Control
FAR	Federal Aviation Regulations
h	enthalpy
HPC	High-Pressure Compressor
HPT	High-Pressure Turbine
IFE	Inverted Flow Engine
IGV	Inlet Guide Vane
JTDE	Joint Technology Demonstrator Engine
LPT	Low-Pressure Turbine
M	Million—
MATE	Materials for Advanced Turbine Engines
N	Rotor Speed
NA HPT	Navy High-Pressure Turbine
NASA	National Aeronautics and Space Administration
NO_x	Oxides of Nitrogen
OPR	Overall Pressure Ratio
PR	Pressure Ratio
SCAR	Supersonic Cruise Airplane Research
SCERP	Stratospheric Cruise Engine Emissions Reduction Program
TEGV	Turbine Exit Guide Vane
THC	Total Hydrocarbons
TSFC	Thrust Specific Fuel Consumption
U	Wheel Speed
V	Velocity
VCE	Variable Cycle Engine
VCEE	Variable Cycle Experimental Engine
VCET	Variable Cycle Engine Technology
VSCE	Variable Stream Control Engine

List of Abbreviations

V_j	Jet Velocity
W_{at2}	Total Engine Airflow

Symbols

Δ	finite difference
α	angular acceleration
θ	relative absolute temperature
η	efficiency

VARIABLE CYCLE ENGINE TECHNOLOGY PROGRAM

**PLANNING AND DEFINITION STUDY
FINAL REPORT**

SECTION 1.0

SUMMARY

The objective of this study was to establish the overall definition and plans for a Variable Cycle Engine Technology (VCET) Program that would be directed towards demonstrating technology of a propulsion system for a second-generation, supersonic commercial aircraft. In accomplishing this objective, the work consisted of defining a demonstrator cycle, identifying critical technologies and component programs, defining demonstrator configurations, and formulating overall program plans and options.

On the basis of results from preceding NASA-sponsored supersonic propulsion system studies conducted by Pratt & Whitney Aircraft, the Variable Stream Control engine (VSCE) concept was selected as the base engine for this study. An alternate cycle, the Inverted Flow Engine (IFE), was selected as a backup engine concept. The main distinction of this configuration is the use of a flow inverter, rather than a duct burner in the VSCE, to achieve an inverted velocity profile for noise reduction. Although the program identified in this study concentrates on the base VSCE cycle, it also reflects the requirements of the IFE cycle.

Critical technology requirements were identified for all components, including the control system and engine installation. The most critical components are: the low-noise, high performance coannular exhaust nozzle; the low-emissions, high performance duct burner; and the hot section (main combustor and turbines). The hot section is particularly critical because of the sustained periods of operation at high temperature levels during supersonic cruise. Also, none of the military or commercial programs, either in process or planned, addresses the time-temperature requirement of a second-generation supersonic transport engine.

Component programs to develop the individual technology concepts were defined in terms of overall objectives and general content. The types of programs for each component range from analytical studies to large scale component rig testing, and the programs are organized to provide an early indication of component performance prior to engine demonstrator testing.

The demonstration of Variable Cycle Engine (VCE) technology can be approached in three ways: a core demonstrator, a low spool technology demonstrator around an existing core, and a full engine demonstrator. A core-oriented program would concentrate on developing high temperature technologies without the complexity of a full engine development, while further development of the duct burner and coannular nozzle would be continued under parallel technology programs. An engine demonstrator, depending on the type of configuration, could demonstrate collectively the coannular nozzle, duct burner and low spool technologies and eventually core technologies as well as total component compatibility. A full technology readiness program would require all three demonstrator types over several phases. The ultimate choice of technology demonstrators is strictly dependent on the specific program objectives and the available funding.

Several demonstrator engines were defined on a preliminary basis. The candidate configurations include: (1) a core from a production F100-PW-100 engine with a scaled VSCE low-pressure spool; (2) a core from the Advanced Turbine Engine Gas Generator (ATEGG) program with a scaled VSCE low-pressure spool; (3) an ATEGG core with a scaled fan from the Advanced Propulsion Subsystem Integration (APSI) Program and a new low-pressure turbine; and (4) a new, advanced technology

demonstrator engine.

Plans for the various technology demonstration programs were prepared ranging in technology achievement and program cost from \$35M to \$380M in 1979 dollars. These programs are structured to provide an inherent

degree of flexibility so that different program options can be established by selecting elements from several base programs. In designing these programs, the philosophy used emphasizes maximizing the technology acquisition for a given level of funding.

SECTION 2.0

INTRODUCTION

Propulsion systems envisioned for second-generation, supersonic commercial aircraft must achieve good fuel economy during both subsonic and supersonic flight segments, while also operating within the environmental constraints of reduced exhaust emissions and noise levels. To meet these demands, Pratt & Whitney Aircraft has been conducting a series of Advanced Supersonic Propulsion Studies as part of the SCAR program under NASA contracts NAS3-16948 for Phases I and II and NAS3-19540 for Phases III and IV. In addition, Pratt & Whitney Aircraft has initiated experimental testing in areas considered critical to a possible second-generation, supersonic transport engine as part of the VCE component test program under NASA contracts NAS3-20602, 20061 and 20048.

In Phases I and II of the supersonic propulsion system studies, various advanced propulsion system concepts were evaluated parametrically. The most promising were identified in Phase III, and the evaluation of these concepts was extended. Early in this work, it became apparent that noise constraints produced a major impact on the selection of engine types and cycle parameters. When the engine/aircraft performance and environmental characteristics were wholly assessed, the Variable Stream Control Engine (VSCE) -- an advanced derivative of a duct burning turbofan engine -- emerged as the most promising approach.

More recently, an Inverted Flow Engine (IFE) concept has evolved from the combination of work accomplished with the VSCE and studies of a rear-valve variable cycle engine. Both the VSCE and IFE concepts employ a two-stream coannular exhaust nozzle system that has shown the potential for a substantial reduction in jet noise.

Phase IV has continued the engine/airframe studies by examining the best methods to achieve the maximum possible gains from propulsion systems with a coannular exhaust.

Because the advantages of the VSCE are dependent on successful development of two new components, a duct burner and a coannular exhaust nozzle, experimental evaluation of these components is being performed under contracts NAS3-20602 and 20061, respectively. The Duct Burner Rig Test Program has been successful in demonstrating a configuration with high combustion efficiency (in excess of 99.5 percent), along with low emissions. The companion Aero/Acoustic Coannular Nozzle Model Program has been successful in demonstrating noise reductions. These noise results have been correlated and will be compared to data acquired from the NASA-sponsored VCE Testbed Program (NAS3-20048). In this program, a large-scale duct burner and coannular nozzle, which serve as the testbed, is installed in back of an F100 engine for evaluating the coannular noise benefit and duct burner performance at operating conditions envisioned for the VSCE. In addition, the F100/testbed configuration permits a demonstration of the two-stream VSCE concept.

These various analytical and experimental test programs, although providing the initial steps towards the evolution of a second-generation, supersonic propulsion system, represent only a small portion of the overall technology requirement. This report describes the total effort in terms of technology requirement and programs to attain the technology needed to bring the state-of-the-art to a point where technology readiness exist. Technology readiness is the time where a decision can be made as to whether a product development program could be initiated.

SECTION 3.0

RESULTS OF STUDY – SYNOPSIS

3.1 CYCLE SELECTION

The Variable Stream Control Engine (VSCE) concept was selected as the base engine cycle for a demonstrator engine. This selection was predicated on the results from NASA-sponsored Variable Cycle Engine/Advanced Supersonic Technology (VCE/AST) programs, in-

cluding the integration studies being conducted by Pratt & Whitney Aircraft and the Supersonic Cruise Airplane Research (SCAR) contractors. An alternate backup engine concept, the Inverted Flow Engine (IFE), was also selected. The conceptual mechanical configurations of the base and alternate engines are compared in Figure 3.1-1.

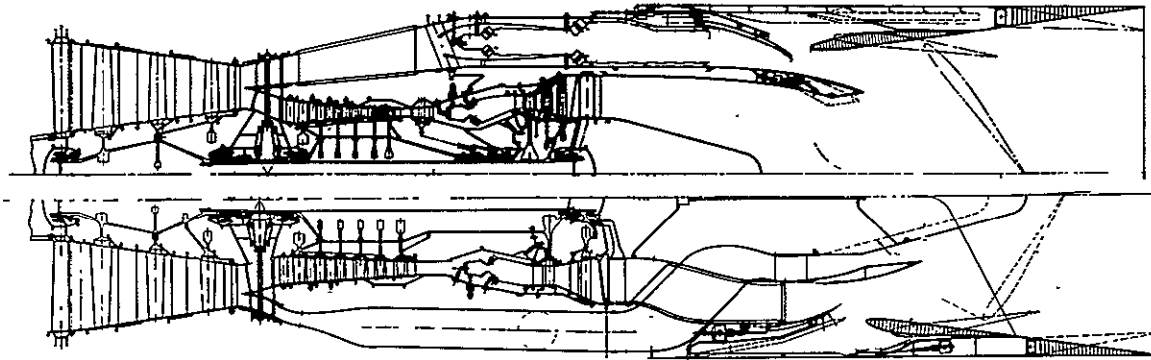

Figure 3.1-1 Conceptual Configuration of VSCE (Top) and IFE (Bottom) - The base cycle, the VSCE, and the alternate cycle, the IFE, offer different approaches to meet the stringent operating and environmental demands of a VCE propulsion system.

The Variable Stream Control Engine (VSCE) is an advanced duct burning turbofan engine concept that makes extensive use of variable geometry components. Unique features of this engine are a low-emissions, high performance duct burner and a low-noise variable geometry, coannular exhaust nozzle. Integrating these components with the engine core system to obtain an independent throttle scheduling capability of the core and fan streams provides an inverted velocity profile for substantial gains in noise reduction as well as propulsive efficiency.

The Inverted Flow Engine (IFE), the alternate backup engine concept, is a low bypass ratio, nonaugmented turbofan engine with a flow inverter to duct the low velocity fan stream flow inside of the higher velocity core stream flow. It has a 0.5 bypass ratio compared to 1.3 for the VSCE and uses an inverter to obtain the coannular noise benefit. In this manner, the engine cycle is matched to provide the inverted velocity profile and the attendant noise reduction. Although preliminary results to date indicate that the overall noise and performance potential of the IFE concept is not

as great as the VSCE, this approach provides a backup which does not require a duct burner. The fundamental technology requirements, however, are similar to those required for the VSCE, especially for the high-pressure spool and coannular nozzle. Another option for these engines could be the use of a stowable jet noise suppressor.

Both the VSCE and the IFE are designed to cruise at turbine temperatures several hundred degrees higher than subsonic transport engines. From a cycle standpoint, both engines benefit greatly from this level of turbine temperature.

3.2 CRITICAL TECHNOLOGIES AND COMPONENT PROGRAMS

The critical technology requirements identified for the base VSCE and for the alternate IFE are listed in Table 3.2-I. Related technology programs, either ongoing or planned, were reviewed for applicability, and plans for recommended component programs were formulated to meet specific VCE technology objectives. These technology plans afford a logical progression of programs which take into consideration facility requirements, technical risk and overall program cost. Two key programs contributing to this technology base are the NASA-sponsored Energy Efficient Engine (EEE) Program and the Military-sponsored Advanced Turbine Engine Gas Generator (ATEGG) Program. In these programs, fundamental technologies in areas of the fan, compressor, main combustor and turbine are being pursued and will provide a basis for aerothermal and structural-mechanical development of selected components.

Optimizing the variable-geometry coannular nozzle design and performance would be accomplished through model tests. In addition, the scope of effort would include determining installation effects of the nozzle with incorporation of the ejector/reverser

configuration as well as integrated model testing in a wind tunnel to optimize overall installed performance.

TABLE 3.2-I

CRITICAL TECHNOLOGIES FOR BOTH THE VSCE AND THE IFE

- High Temperature Technology
 - High- and Low-Pressure Turbines
 - Durability
 - High Performance
 - Main Combustor
 - Low Emissions
 - High Performance
 - Durability
- Variable Geometry Turbomachinery
 - Fan and High-Pressure Compressor
 - High Efficiency
 - Stability
- Full Authority Integrated Electronic Control System
- Variable Geometry
 - Coannular Exhaust Nozzle and Reverser
- Stowable Suppressor
 - For the VSCE Only
 - Duct Burner
 - Low Emissions
 - High Performance
 - Durability
 - For the IFE Only
 - Flow Inverter

Key elements in verifying the coannular noise benefit are correlation of static model acoustic data to large scale VCE testbed acoustic data and correlation of the large scale testbed to a flight system with forward speed flight effects. To obtain noise data with forward speed flight effects, testing the VCE testbed in the NASA-Ames 40 by 80 foot wind tunnel has been incorporated in the program plan.

The duct burner will require extensive analytical effort and experimental testing to demonstrate low-emissions, high aerothermal performance and durability. As planned, this technology effort supplements the current work being performed under the Duct Burner Segment Rig and VCE Testbed Programs. Further work would include diffuser design and rig testing to optimize the duct burner in relation to the diffuser configuration. Scaling effects to flight engine size would be verified as part of a large scale sector rig test program. Demonstrator engine testing would verify the overall emissions, performance and, to a limited extent, durability characteristics.

Requirements for hot section components, especially to improve durability, are a particularly important area because of the stringent operating requirements as well as demands for long commercial life. This is even more critical for the backup IFE concept which operates at 56°C (100°F) higher temperature than the VSCE. A series of analytical studies and experimental rig tests has been defined to address the technology requirements for the combustor and turbine subsystems. This work encompasses the evaluation of advanced materials, improved cooling techniques and advanced aerodynamics. The culmination of this effort consists of an engine demonstration of key components, first as part of a core engine test to substantiate performance and structural integrity, then in a full engine test program. Results from this effort feed directly into the AST program and could also be applicable to a military or a sub-

sonic commercial technology venture which may be in process or under consideration. Unfortunately, the reverse is not true since the hot section in AST engines operates at higher temperatures for longer periods of time than the hot section in a commercially-envisioned subsonic power plant or a military application.

Technology programs have also been identified for variable geometry components such as the fan and compressor systems. The overall compression system, as envisioned, uses variable geometry components, and much of the compressor technology relies on the advancements from the EEE, ATEGG and APSI (Advanced Propulsion Subsystem Integration) Programs. As an example, some of the aerodynamic refinements in the EEE single-stage fan could be assimilated into the multistage fan system. Optimization of the multistage fan and compressor design, aerodynamic efficiency and stability would be accomplished through a selected sequence of cascade and component rig test programs. Following rig testing, these components would be integrated into a demonstrator for technology verification.

A program for the control system would be directed towards verifying the accuracy and responsiveness of a full-authority electronic control in fulfilling the numerous integrated engine/inlet/airframe functions. Studies of the control, interface and actuation systems would be performed to define the control system and resolve any unique problems. Demonstration of the control system technologies would be made with the use of either a new control design or a breadboard control for reduced program cost.

A program has been outlined to demonstrate flow inverter technology required for the IFE concept. Specific requirements such as efficient flow inversion with a minimum of penalty and durability considerations would be addressed by studies and model testing. This program would not be initiated unless the

VSCE concept with the duct burner was not successful or the IFE cycle proved better than the VSCE.

3.3 DEMONSTRATOR APPROACHES

The demonstration of VCE technology can be approached in several ways: by means of rig or component programs tied to core type demonstration vehicles or full engine demonstrators. The ultimate approach will be dependent on the specific objectives outlined for the program, the results obtained as the program progresses and the manner in which the program funding becomes available.

A core demonstrator vehicle offers several inherent advantages in developing supersonic engine technology. This approach enables a low cost demonstration of key high temperature components, the main combustor and the high-pressure turbine, at representative VCE operating conditions without the added development complexity of a full engine. High temperature component validation is vital to the success of a supersonic engine whether it is a VSCE, IFE or some other configuration. Reduction of the turbine temperature by only 110°C (200°F) reduces the airplane range by 10 percent which influences the practicality or feasibility of an AST. The use of a core demonstrator permits concentrating on the high spool and developing technology. Further development of the coannular nozzle and duct burner components would be pursued under parallel efforts such as a follow-on to the VCE Testbed Program. In addition, a core demonstrator provides a foundation with growth potential into a full engine at the appropriate time for total technology readiness.

A full engine demonstrator permits the collective and, especially the interactive evaluation of all components in an engine operating environment. In the case of a VSCE, it is absolutely necessary that these interactions

between the various components be fully exercised and evaluated. While it is conceivable that technology readiness could be achieved through a core demonstrator approach only for some engine other than the VSCE, this is not recommended for the supersonic transport engine. As a test vehicle, a demonstrator engine could be configured as either an all new design or a derivative based on use of an existing core engine such as the ATEGG.

An advanced low spool engine demonstrator built around an existing core would allow demonstration of low spool components without the complex problems and cost of developing the core in the same engine. This approach allows concentration on the low spool components as well as the duct burner and coannular nozzle without having to develop a core. Eventually, a complete technology low spool demonstrator engine built around an existing core, can be integrated with a high spool into an advanced engine demonstrator. A new advanced technology demonstrator engine could be procured in either the size of a future flight propulsion or in subscale size, while demonstrators based on existing hardware are restricted to the size of their components.

For a demonstrator engine based on existing or near term technology, several available cores were screened for suitability. From this screening an F100 core, ATEGG core and Energy Efficient Engine core were selected as candidate approaches for a Variable Cycle Experimental Engine (VCEE). Results from preliminary design analyses, however, indicated an appreciable mismatch between the Energy Efficient Engine core and low-pressure spool components mainly due to the high-pressure ratio of the Energy Efficient Engine cycle. Consequently, this approach was eliminated from further evaluation.

A demonstrator engine based on the F100 core provides a vehicle capable of verifying the VCE cycle concept, in addition to demonstrating

advanced low spool technologies, the duct burner, the coannular nozzle and the control system. Use of the proven F100 core offers core reliability and the lowest cost approach to a full engine test.

The use of the ATEGG core in an engine configuration is a viable approach and one recommended by Pratt & Whitney Aircraft for a demonstration using an existing core since it enables the technology demonstration to encompass certain key high temperature technologies, specifically, high-pressure turbine performance/durability and main combustor durability. Because the geometry of the ATEGG core is compatible with VCE turbine requirements, only slight cycle modifications would be required to permit a valid demonstration of these technologies. An engine based on the ATEGG core can be configured with either a scaled advanced VSCE low-spool or a scaled APSI fan design and a new advanced low-pressure turbine. Integration of the APSI fan capitalizes on the use of an existing advanced technology design to reduce program cost. However, this configuration limits the demonstration of advanced VCE fan technology.

For each of the engine demonstrator configurations discussed above there is a trade-off between the program cost and the initial level of technology to be demonstrated. Initial

level of technology refers to where the minimum amount of change is made to an engine in order to demonstrate some of the VCE technology. In the case of an F100 demonstrator, the core (high-pressure compressor, main combustor and high-pressure turbine) would remain unchanged while a new fan and low-pressure turbine is installed, along with a coannular nozzle system, a duct burner and the necessary controls to permit the engine to operate. The same components could be demonstrated with an ATEGG core and, in addition a new high-pressure turbine, would be designed using the philosophy of an advanced VCE engine but would still drive an existing high-pressure compressor so that the turbine might not be a completely unique VSCE. The turbine could contain the VSCE cooling scheme but aerodynamically would match an existing high-pressure compressor. The ATEGG combustor could be modified to reflect a possible cooling scheme of an advanced engine. However, to reduce costs, a new combustor would not be initially proposed. By contrast, a new engine would demonstrate all the required new technology, but would have to solve all the component problems in one engine, obviously at a higher cost in initial funds than in the case where existing components and technologies are employed. Key cycle parameters for each demonstrator are tabulated in Table 3.3-I.

TABLE 3.3-I
ENGINE CYCLE PARAMETER COMPARISON

	Candidate VSCE Demonstrator Cycles		
	F100 Core/VSCE Low Spool	ATEGG Core/ VSCE Low Spool	VSCE Core and Low Spool
Bypass Ratio	1.3	1.3	1.3
Fan Pressure Ratio	3.3	3.3	3.3
Overall Pressure Ratio	23.0	18.3	20.0
Maximum Combustor Exit Temperature ~ °C (°F)	1400 (2560)	—	1480 (2700)
Engine Airflow Size ~ kg/sec (lb/sec)	132 (290)	122 (268)	113 - 408 (250 - 900)

3.4 PROGRAM PLANS

A complete program plan to provide technology readiness has been outlined by starting with the smallest component and establishing a logical sequence of testing and analysis to verify that particular component technology. This program is then tied into the next larger component program until the overall engine technology program has been established. In Figure 3.4-1, this overall effort is illustrated as Program D and has a cost of \$380 million in 1979 dollars over a 9 year period. Realizing that the commitment to such a program might not occur in the next year or so, the program has been broken down into a series of smaller programs that all ultimately lead to the final program and permit initiation of effort with less money.

The smallest step is a High Temperature Validation effort which takes place over a five year period with a commitment of \$35 million (Program A in Figure 3.4-1). If more money is initially available, Program B, which extends the core technology beyond that effort in Program A, could be started. This program includes all the work in Program A, plus extensive effort with a core demonstrator. The next logical step is Program C. This effort includes all the work in Programs A and B, plus a full engine demonstration. For minimum cost, the programs are all shown starting at time zero. Obviously, there is an infinite variety of options available since, for example, one could start with Program A and after some period of time switch to B, or C, or even D. However, the costs and the time to completion would have to be recalculated.

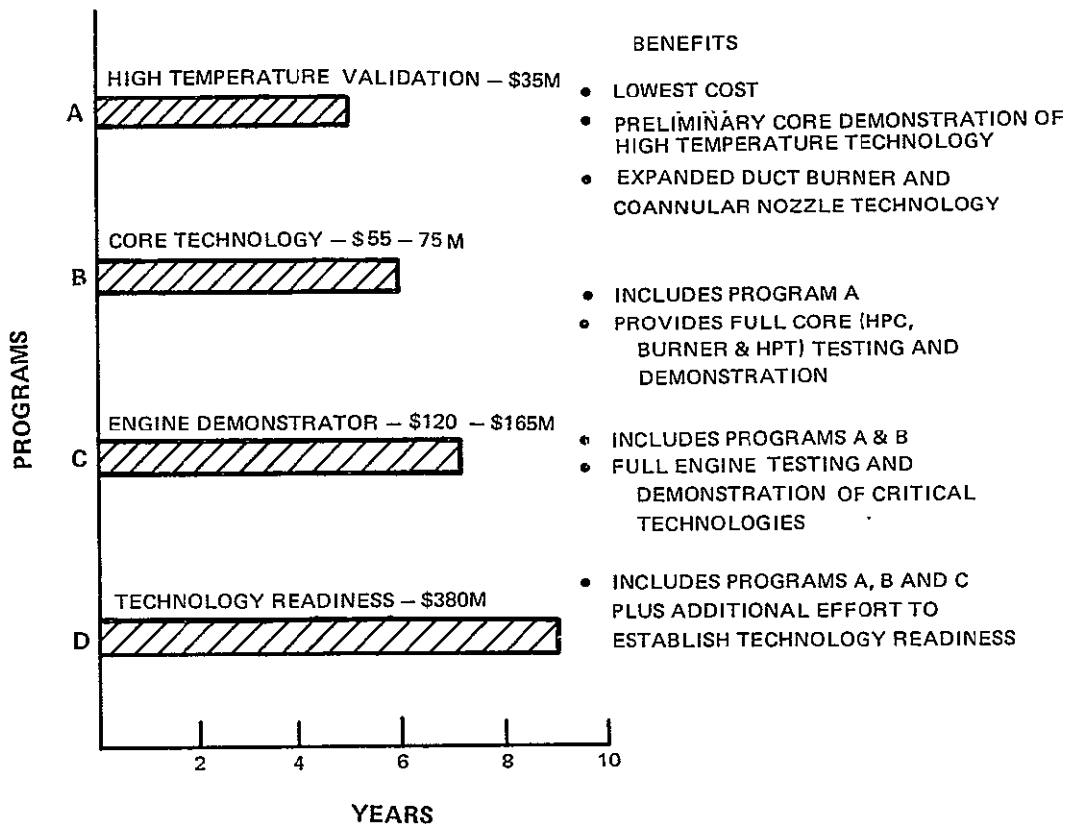

Figure 3.4-1 VCET Programs - The different programs are organized to achieve specific levels of technology readiness that are contingent on the available funding.

As mentioned previously, there are options within the basic program depending, for example, on the core engine selected. This introduces another variable that would be dependent on the money available. A synopsis of each of the four program types plus a fifth option is presented in the following paragraphs.

Program A – High Temperature Validation

This program provides the technology validation of the most critical components and forms the base for the other programs. It includes expansion of the current VCE Testbed Program, covering further duct burner technology development as well as large scale jet noise tests at simulated flight conditions in the NASA Ames 40 x 80 wind tunnel. Basic duct burner and coannular nozzle research programs would be expanded through rig and model test programs. Specifically, the duct burner program would be expanded to simplify the duct burner and determine the interactive effect of the fan diffuser requirements. A key element of the High Temperature Validation Program would be the demonstration of critical main engine high temperature technologies, in specific, the high-pressure turbine component. This would include turbine aerodynamics and cooling, combustor liner cooling, and the application of advanced material technologies would be demonstrated in rigs as well as in a core test. The elements of this program are listed in Table 3.4-1 along with the other programs.

Program B - Core Technology

The scope of work in this program extends the preceding effort to encompass all of the VCE core technologies. This provides an essential foundation for a full engine demonstrator program.

Program C - Engine Demonstrator

This program is directed towards demonstrating VCE technologies in a full engine environ-

ment through a series of performance, acoustic and limited durability tests.

Program D - Technology Readiness

The verification of total technology readiness, as planned in this program, includes a substantial amount of additional component technology development in order to demonstrate all of the VCE goals. Extensive engine testing would be conducted to verify the performance and durability to achieve the level of confidence required to allow future initiation of full engine development.

Program E - Reduced Cost Demonstrator

This program was formulated to provide an alternate full engine test effort at reduced cost. This program provides only a limited demonstration of advanced VCE technologies and certain key technology elements such as the high temperature validation are omitted. However, this demonstrator vehicle could be used as a building block test engine to incorporate some key technologies in subsequent growth generations. This program does not appear to be as cost effective as the other programs (A-D) from a technology demonstration standpoint.

Except for the Reduced Cost Demonstrator Program, each program builds on the foundation provided by the previous one. It is noteworthy to emphasize that the cost and overall effort of the initial programs are included in the subsequent programs to provide a logical progression in technology and funding. The use of different demonstrator configurations in a specific program accounts for the range in cost. For example, in the Core Technology Program (Program B in Figure 3.4-1 and Table 3.4-1) the lower cost reflects use of the ATEGG core as a demonstrator, while the higher value indicates the cost for a new core. If money was not a consideration the program could progress to all new components. Therefore, since funding is limited, use of the ATEGG core provides a viable alternative.

TABLE 3.4-1

TECHNOLOGY DEMONSTRATION PROGRAMS

PROGRAM A - HIGH TEMPERATURE VALIDATION

Program Elements:

- Expanded VCE Testbed Program
 - Duct Burner Development
 - Coannular Nozzle Wind Tunnel Jet Noise Testing
- Expanded Duct Burner Segment Rig Basic Research
- Coannular Nozzle Model Basic Research
- VCE High-Pressure Turbine Technology
 - Cascade/Rig Programs
 - Turbine Substantiation Through Core Testing

Total Cost: \$35M

Total Scheduled Time: 5 years

PROGRAM B - CORE TECHNOLOGY

(NOTE: Includes Total Cost and Effort of Program A)

Program Elements:

- High-Pressure Compressor Aerodynamics
- Main Combustor Cooling/Emissions/Durability
- High-Pressure Turbine Cooling/Performance/Durability
- Core Technology Substantiation through Core Tests

Total Cost: \$55 to \$75M

Total Scheduled Time: 6 years

PROGRAM C - ENGINE DEMONSTRATOR

(NOTE: Includes Total Cost and Effort of Programs A and B)

Program Elements:

- Fan Aerodynamics
- Low-Pressure Turbine Aerodynamics
- Duct Burner Performance/Emissions/Durability

- Coannular Nozzle Aerodynamics and Acoustics
- Engine Performance Tests
- Engine Noise Test
- Limited Durability Test

Total Cost: \$120 to \$165M

Total Scheduled Time: 7 years

PROGRAM D - TECHNOLOGY READINESS

(NOTE: Includes Total Cost and Effort of Programs A, B and C)

Program Elements:

- Sufficient Substantiation Testing of Components and Engine to Provide Confidence to Proceed with Full Engine Development
- Expanded Cascade/Rig and Materials Programs
- Expanded Demonstrator Testing
 - Performance
 - Durability

Total Cost: \$380M

Total Scheduled Time: 9 years

PROGRAM E - REDUCED COST DEMONSTRATOR

Program Elements:

- Expanded VCE Testbed Program
 - Duct Burner Development
 - Wind Tunnel Noise Testing
- Expanded Duct Burner Segment Rig Basic Research
- Limited Fan Aerodynamics
- Limited Low-Pressure Turbine Aerodynamics
- Limited Duct Burner Performance/Emissions/Durability
- Limited Coannular Nozzle Aerodynamics and Acoustics
- Limited Engine Performance Test

Total Cost: \$65M

Total Scheduled Time: 6 years

3.5 FLIGHT TESTING

Although flight testing is beneficial, it is not necessary for substantiating engine technology readiness. Basically, there are two different approaches for a flight program, each with many options available. The least expensive and possibly most effective is the use of an engine as a supplemental power plant in a separate pod of an aircraft. As a second approach, the engine or engines can be used as the sole power source, in which case a complete engine certification would be required. With either approach, the engines would be an all new configuration or based on an existing technology core such as the F100 or

ATEGG. The flight program could be conducted initially at subsonic conditions with an existing airframe, then subsequently installing the engine into a supersonic aircraft for evaluation at high Mach number conditions.

From a cost standpoint, it would be more propitious to start with an existing core, either the F100 or ATEGG, and install the engine as a supplementary power plant in a subsonic vehicle. After subsonic performance has been characterized and overall confidence in engine reliability and durability achieved, testing would be directed towards flight testing the engines in a supersonic vehicle.

SECTION 4.0

DISCUSSION OF RESULTS

4.1 CYCLE SELECTION

4.1.1 Introduction

Selecting a base engine configuration that reflects the most promising concept in terms of mechanical design, predicted performance and potential to make environmental requirements for a future supersonic aircraft was the first of four technical tasks completed in this program. The engine served as a basis to identify critical technology requirements in order to structure component demonstration programs as well as engine test programs for technology demonstration.

As discussed in the following section, the Variable Stream Control Engine (VSCE) concept was selected as the base study engine. This concept is characterized by a flexible throttle schedule, which combined with a low-emissions duct burner and a low noise, variable geometry coannular nozzle, allows independent control of the fan and core exhaust streams. This unique throttle scheduling provides the inverse velocity profile (bypass stream nozzle velocity greater than the core stream nozzle velocity) to effectively take advantage of the coannular noise benefit.

A backup approach, the Inverted Flow Engine (IFE) concept, was also selected for consideration in this study. This engine achieves the desirable inverted velocity profile through inverting the flow of the fan and high velocity core streams as opposed to an independent throttle control schedule of the two flow streams and does not rely on use of a duct burner.

4.1.2 Variable Stream Control Engine (VSCE)

Selection of the VSCE concept, engine study designation VSCE-502B, as the base engine

was predicated on results acquired from preceding Supersonic Cruise Airplane Research (SCAR) studies and Pratt & Whitney Aircraft Advanced Supersonic Propulsion studies.

These studies identified the VSCE as the most promising engine concept on the basis of comparative evaluation of more than 100 different engine study cycles and configurations, including conventional, unconventional and other VCE concepts. The results led to the selection of the VSCE-502B as a baseline study engine during the planning and definition phase of the current VCE Testbed Program (NAS3-20048).

Two key components in the VSCE are the duct burner and the coannular exhaust nozzle. Figure 4.1-1 shows the basic mechanical arrangement of the major components. Also shown is a conceptual illustration of the inverted velocity profile during the takeoff mode of operation. As defined, the engine is a twin spool configuration similar to a conventional turbofan. The low-pressure spool consists of an advanced multistage, variable geometry fan and a two-stage turbine. The high-pressure spool consists of a variable geometry compressor driven by an advanced, high temperature single-stage turbine. Both the primary combustor and the duct burner utilize low-emissions, high efficiency combustion concepts. The exhaust nozzle system is a coannular (concentric annular) design featuring variable throat areas in both streams as well as an ejector/reverser system. Integration of the various engine and nozzle functions is managed by a full-authority, digital, electronic control system.

The engine cycle operates at a fan stream jet velocity that is significantly higher than the core stream velocity during takeoff (Figure 4.1-1) for effective noise suppression. Also,

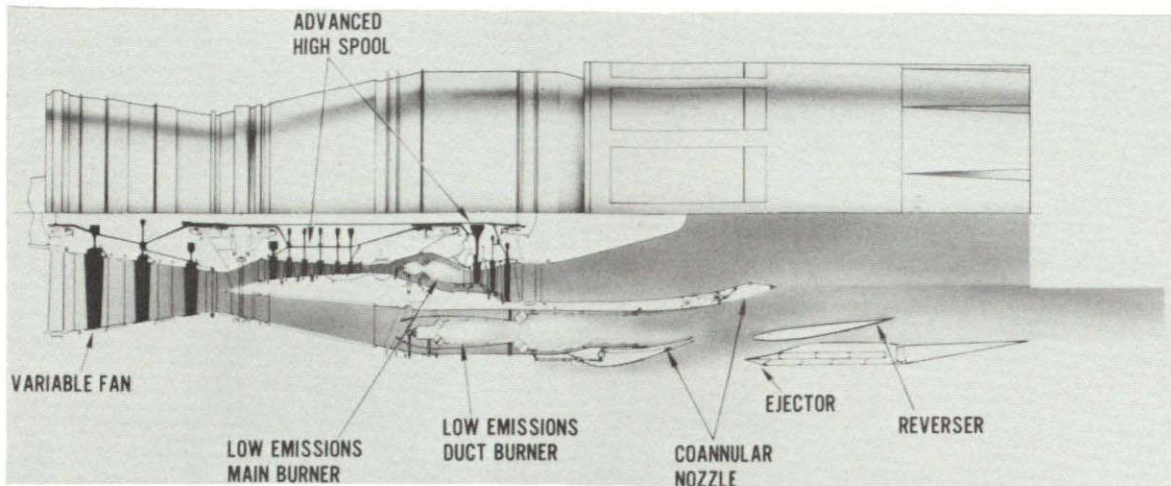

Figure 4.1-1 Cross sectional View of Variable Stream Control Engine – The independent control of the two flow streams, which is produced through the interaction of the low-emissions duct burner and coannular nozzle, provides a substantial noise benefit along with improved fuel consumption. (The engine is illustrated in the takeoff operating mode showing the inverted velocity profile.)

this concept, through efficient management of the fan and core stream components, achieves the performance levels of a moderate bypass ratio turbofan at subsonic speeds and closely approaches the best attainable supersonic cruise fuel consumption of a nonaugmented turbojet.

Improvements offered by the VSCE in relation to a first-generation supersonic propulsion system are identified in Table 4.1-I. The reduction in takeoff noise by 8 dB is directly attributed to the coannular exhaust effect. The 25 percent lower propulsion system weight results from the two-stream turbofan configuration, which reduces the size and weight of the core, and from the use of advanced technology components. In the area of fuel consumption, the notable improvement in subsonic fuel consumption is especially important since a VSCE-powered aircraft must be capable of cruising substantial distances over land where supersonic operation may be prohibited by sonic boom noise constraints.

TABLE 4.1-I

VARIABLE STREAM CONTROL ENGINE CHARACTERISTICS RELATIVE TO FIRST-GENERATION SUPERSONIC TRANSPORT TURBOJET

Δ Jet Noise	- 8 dB (Unsuppressed)
Δ Engine Weight (%)	-25 (Equal Flow Size)
Δ Fuel Consumption (%)	
Subsonic Cruise	-20
Supersonic Cruise	0 to +3 (function of required power setting)

The net effect of VSCE characteristics on supersonic transport airplane performance is very significant, as indicated in Figure 4.1-2, with a 25 percent range improvement and an 8 dB reduction in takeoff noise. Thus, this advanced technology engine concept offers a practical airplane range capability with acceptable noise levels.

4.1.3 Inverted Flow Engine (IFE)

The Inverted Flow Engine (IFE) concept, study designation IFE-600, was selected as the backup to the VSCE-502B base cycle. The IFE-600 is a relatively new cycle concept. Preliminary performance and integration studies suggest that this cycle is not as attractive as the VSCE-502B.

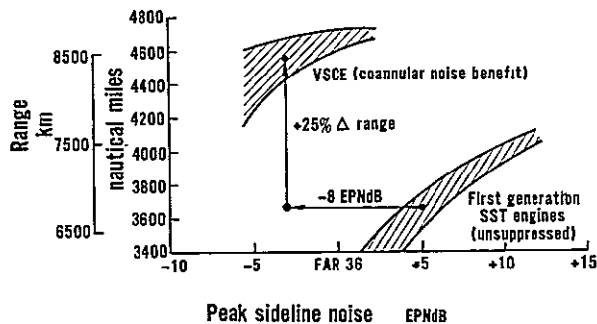

Figure 4.1-2 Potential Improvements of VSCE Over First-Generation Supersonic Transport Engines - The use of advanced technology components, in conjunction with the independent control of the two flow streams, offers a 25 percent increase in range and an 8 dB noise reduction.

The IFE is an advanced, nonaugmented, low-bypass ratio turbofan which utilizes a fixed flow inverter at the low-pressure turbine exit plane to duct higher velocity and temperature core gas flow to the outer stream and the lower velocity and temperature fan flow to the inner stream. This inverted flow provides conditions to achieve a coannular noise benefit, and flow inversion occurs in all operating modes. The absence of an augmentor in the fan stream does not allow the flexibility to control or regulate both core and fan pressure and temperature as the VSCE-502B concept. The design cycle parameters of the alternate IFE cycle are listed in Table 4.1-II along with the VSCE-502B for comparison.

The general mechanical configuration of the IFE is shown in Figure 4.1-3. Overall, the turbomachinery requirements and technologies are very similar between the VSCE and

TABLE 4.1-II
SELECTED CYCLE PARAMETERS AT SEA LEVEL STATIC CONDITIONS

	VSCE-502B	IFE-600
Corrected Inlet Airflow - kg/sec (lb/sec)	272 - 408 (600 - 900)	272 - 408 (600 - 900)
Bypass Ratio	1.3	0.5 (2.0 when inverted)
Fan Pressure Ratio	3.3	3.5
Overall Pressure Ratio	20	20
Compressor Exit Temperature - °C (°F)		
@ Sea Level	1204 (2200)	1450 (2650)
@ Maximum	1480 (2700)	1585 (2800)
Augmentor	Duct Burner	None
Maximum Augmentation Temperature - °C (°F)	1426 (2600)	---
Jet Noise Control	Coannular Benefit	Coannular Benefit
Number of Stages	3-6/1-2	3-6/1-1

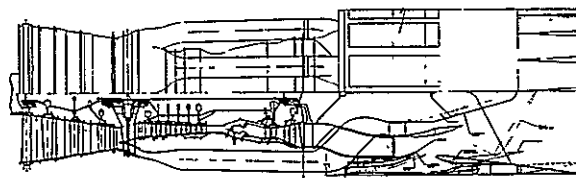

Figure 4.1-3 Cross Section View of Inverted Flow Engine - As the backup to the VSCE-502B, this engine configuration uses a flow inverter to attain the coannular noise effect.

the IFE. In the IFE twin spool configuration, the low-pressure turbine is a single stage unit. Immediately following the turbine is the flow inverter which ducts the fan flow through the core stream by means of a series of aerodynamic struts to an annulus inboard of the core flow. The remaining components closely parallel the VSCE concept in terms of mechanical design and level of technology. The fan is a multistage system with variable geometry capability. The high-pressure spool contains a variable geometry compressor and an advanced single-stage turbine. The combustor is an advanced concept designed to achieve low emissions and high performance. The exhaust nozzle is a coannular system with variable area capability in both flow streams.

It is important to point out the high degree of commonality that exists between the VSCE and IFE, especially in the core spool, fan and coannular nozzle components. Therefore, demonstration of these common component technologies for one engine type provides demonstration for the other.

4.2 CRITICAL TECHNOLOGIES AND COMPONENT PROGRAMS

4.2.1 Introduction

The base engine concept, the VSCE-502B, was reviewed to identify those technologies critical to the advanced supersonic propulsion system. As part of this work, program goals and requirements were established for developing these technologies. The critical technology components, which are predicated on a preliminary design of an advanced propulsion system, are listed in Table 4.2-I. Also included is the critical technology for the alternate cycle.

TABLE 4.2-I
CRITICAL TECHNOLOGIES

DUCT BURNER

- Low Emissions
- High Performance
- Durability

COANNULAR EXHAUST NOZZLE

- Low Noise
- High Performance
- Variable Geometry Components
- Reverser

HIGH TEMPERATURE VALIDATION

High and Low-Pressure Turbines

- Durability
- High Performance

Main Combustor

- Low Emissions
- High Performance
- Durability

VARIABLE GEOMETRY COMPONENTS

Fan and High-Pressure Compressor

- High Efficiency
- Improved Stability

FULL AUTHORITY INTEGRATED ELECTRONIC CONTROL SYSTEM

FLOW INVERTER

The critical VCE technologies fall into two categories: (1) technologies for general future gas-turbine applications, and (2) technologies unique to the VCE concept. The first category encompasses such areas as high temperature technology which have broad application for future gas-turbine engines, yet reflect large advancements beyond those currently being pursued under various programs at Pratt & Whitney Aircraft. Technologies in the second category are unique to the VCE concept such as the duct burner and coannular exhaust nozzle. These components are vital, but because of their specialization, no help in developing the technology can be expected from component development effort in any other programs.

The majority of critical technology requirements are common to both the base and alternate engines. Specifically, core technologies, including the high temperature components; controls; and variable geometry, low-noise, high-performance coannular exhaust nozzle, are common. Fan technologies are also similar. Although the specific low-pressure turbine work requirements differ between the VSCE and IFE, the cooling and durability aspects are quite similar. Only the substitution of flow inverter technology for the duct burner of the base VSCE concept alters the general overall technology requirements.

To address the various technology requirements, programs were formulated on a general basis to outline the overall program plan and scope of work. The individual programs are directed towards demonstrating component technology with minimum cost and technical risk. In this manner technology would be first assessed during cascade or small scale model tests to maximize data return at the lowest cost before progressing to the detail design stage. Large scale component rig tests would then be conducted to verify and assess performance and safety prior to integrating this technology into a core or full engine demonstrator. Each technology program is tailored to be compatible with any inherent limitations of the test facility.

Although separate from the component technology programs, one general requirement that has been identified is the need for a preliminary engine design effort. This type of work would be directed towards refining the selected cycle and would provide better visibility of the component preliminary design definition.

The following sections describe programs for the various critical components.

4.2.2 Variable Geometry Exhaust Nozzle and Installation Technology

Integration of an advanced engine into a second-generation, supersonic transport requires unique installation technologies not found or anticipated in either subsonic commercial or military applications. In particular, the need for a low noise, high performance fully variable supersonic nozzle presents unique nozzle technology requirements. General installation technologies such as engine/inlet and engine/airframe integration are unique to the specific airframe and must be addressed as a joint effort with the airplane companies.

A promising method for reducing jet noise with minimum penalty to the propulsion system is

the unique inverted velocity profile of the coannular exhaust nozzle system which has been demonstrated during nozzle model testing. In addition to coannular flow, nozzle technology should consider commercial requirements that may dictate the use of an integrated reverser system. The nozzle must also provide for fully and independently variable primary and duct stream jet areas for VSCE cycle matching. The primary areas of nozzle technology development would focus on aerodynamic and acoustic performance within the context of a workable mechanical arrangement.

Installation of a advanced cycle in an advanced supersonic transport presents unique integration problems that will require information beyond the current state-of-the-art. This integration technology would include engine mounting arrangement, packaging, and inlet requirements such as variable geometry considerations and structural/mechanical aspects.

Related VCE nozzle and installation programs currently in progress at Pratt & Whitney Aircraft are identified in Figure 4.2-1 along with recommended VCE programs. Of particular interest in the area of coannular nozzle technology is the work being performed under the NASA-sponsored Coannular Nozzle Model Test Program and VCE Testbed Programs (NAS3-20061 and NAS3-20048, respectively).

The Coannular Nozzle Model Program is aimed at defining and evaluating attractive aero/acoustic nozzle designs for a VCE system. This work has encompassed parametric static testing of coannular nozzle geometries to acquire both aerodynamic and acoustic data for development of analytical prediction systems. Advanced nozzle model systems have been tested in the NASA-Lewis wind tunnel. In addition, a model simulating the VCE testbed nozzle geometry has been static tested to provide an aero/acoustic correlation between model data and full size testbed engine data.

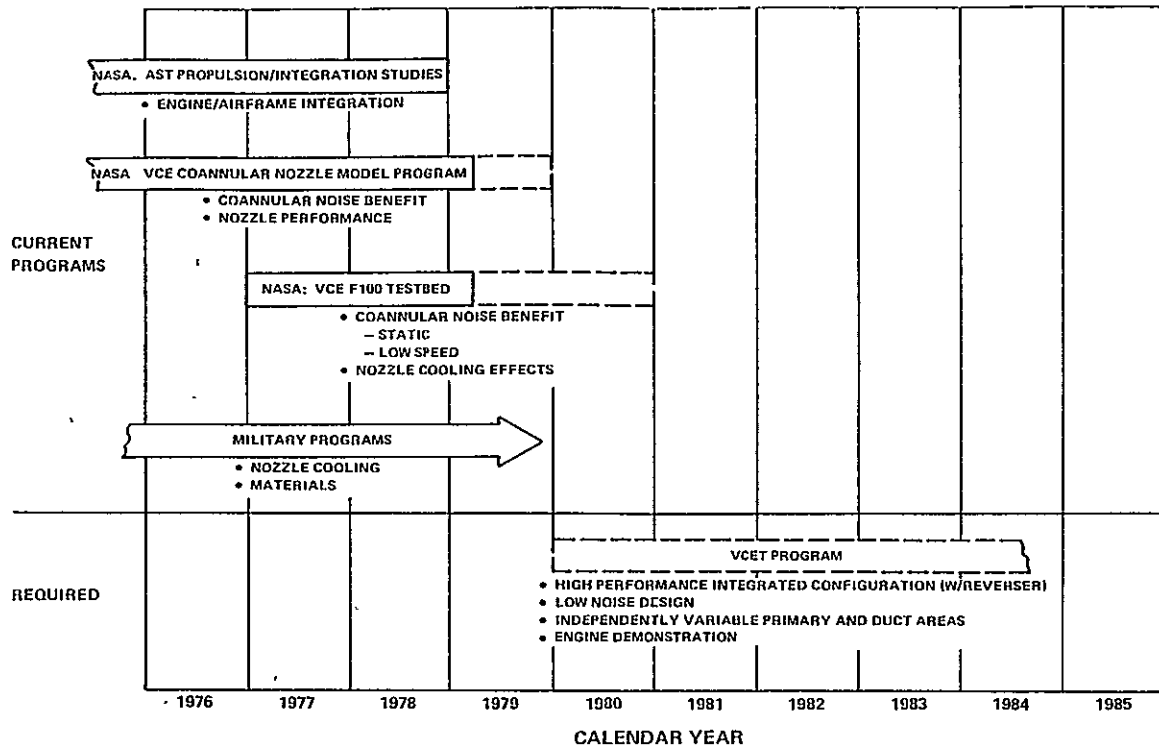

Figure 4.2-1 Exhaust Nozzle and Installation Technologies - The current technology programs will provide the basis to demonstrate an advanced nozzle/ejector/reverser configuration during the engine demonstrator test as well as ensure engine/airframe compatibility.

As an extension to this effort, two additional nozzle programs are planned. First, a Supersonic Nozzle Design Study will provide aerodynamic flowpaths for a subsequent NASA-Langley nozzle test program. Second, following the current model program, the Internal Aerodynamic Analysis Development Program will concentrate on improving internal aerodynamic analysis and performance prediction capabilities for supersonic coannular nozzles.

The VCE Testbed Program is designed to provide a large-scale demonstration of two critical technology components, the duct burner and the coannular nozzle. The VCE testbed configuration, which is shown in Figure 4.2-2, utilizes the F100 engine as a gas generator and adds a staged-Vorbix duct burner, a F401

nozzle, and an acoustically-treated ejector. In this program, the inverted velocity profile produced through the interaction of the duct burner and the coannular nozzle will be demonstrated at the operating conditions envisioned for an advanced VCE cycle. Static testing will demonstrate the aero/acoustic characteristics of this coannular nozzle system.

In the area of engine/airframe integration, Pratt & Whitney Aircraft has been involved in a multiphase study under the NASA-sponsored Supersonic Cruise Aircraft Research (SCAR) Program. Since 1972, the work in this program has addressed a broad range of subjects, including engine cycle screening and refinement, parametric studies as well as the evaluation of performance and environmental characteristics.

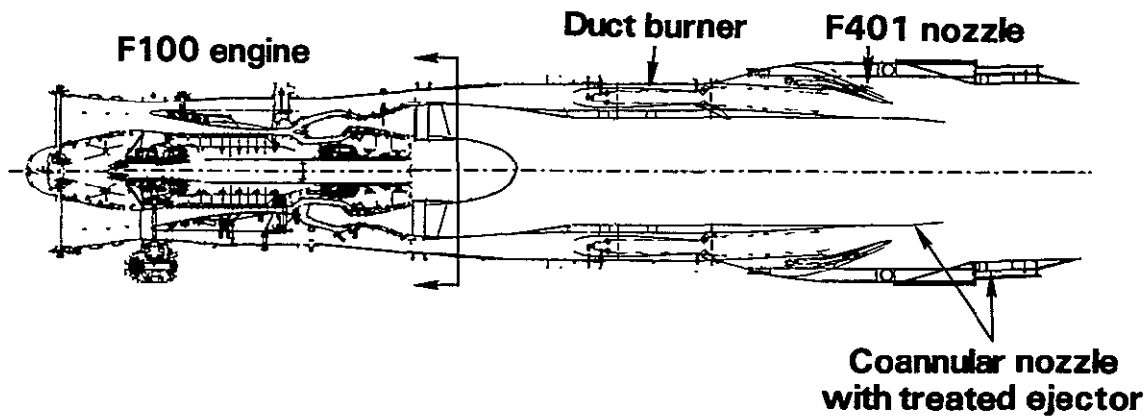

Figure 4.2-2 VCE Testbed Configuration – Forward of the testbed, which incorporates the duct burner and coannular nozzle system, is a F100 gas generator. This configuration enables experimental evaluations of large scale hardware in a realistic operating environment.

More recent work has concentrated on engine/airframe integration, particularly with the VSCE installed in advanced supersonic aircraft concepts supplied by the Boeing Commercial Airplane Company, the Douglas Aircraft Company, and the Lockheed California Company. These integration studies have investigated installed performance, noise and emissions, and engine mounting/packaging.

These programs with the airframe companies provide the initial technology base. However, extensive additional work is necessary to meet the VCE nozzle and installation requirements. The recommended technology programs are listed in Table 4.2-II, and a description of the content of each program is presented in the following paragraphs.

Nozzle Model Testing – The low noise and high performance of the coannular nozzle system needs to be considered and optimized in light of airframe integration requirements. Further model testing is necessary to refine the method of flow control and thrust reversal as well as to further refine the internal nozzle aerodynamics.

TABLE 4.2-II

REQUIRED NOZZLE/INSTALLATION PROGRAMS

- Nozzle Programs
 - Nozzle Model Tests
 - Integrated Nozzle Model Tests
- Additional VCE F100/Testbed Tests
 - Low-Speed Wind Tunnel Evaluation
- Engine/Airframe Integration Studies
- Engine Demonstrator
 - Performance/Noise Demonstration

The integration effects between the nozzle and airframe structure must be examined in order to provide information to the airframe companies for their studies and to determine the ultimate installed performance potential. Testing in this program, which would be conducted in a wind tunnel, would be a joint effort between Pratt & Whitney Aircraft and the airframe companies. Different nozzle geometries would be reviewed analytically and selected configurations for each airframe company would be tested with the wing and nacelle to

assess installed performance. Results from this work would provide a basis to select the coannular nozzle configuration for a demonstrator engine.

Additional VCE Testbed Testing – The scheduled aero/acoustic test under the VCE Testbed Program will characterize the coannular noise effect at static conditions. However, to fully evaluate noise for a future supersonic transport, a correlation of static to low-speed flight characteristics is critical.

As a recommended follow-on effort to the current VCE Testbed Program, the F100/testbed system would be tested in the NASA-Ames 40 by 80 foot wind tunnel. The test configuration would consist of the F100/testbed wrapped in a boilerplate-constructed nacelle with a subsonic inlet. Because of the nature of testing, the acoustic test would probably be performed with an accompanying static noise/performance calibration.

Engine/Airframe Integration Studies – The engine installation affects the engine design as a result of envelope constraints and inlet pressure profile and to a lesser extent the airframe. To study the installation idiosyncracies imparted by the engine configuration, integration studies would be conducted with the SCAR airframe contractors. The work would be directed towards identifying and resolving engine/airframe interfaces, inlet/engine requirements, bleed and accessory requirements, structural considerations, and noise suppression techniques.

Engine Demonstrator Test – This test would demonstrate for the first time an engine size coannular nozzle having complete variability of the fan and primary nozzle areas, along with a fully variable ejector and thrust reverser. Furthermore, this would be the first test of this refined nozzle with the advanced technology duct burner to demonstrate the low noise levels of second-generation supersonic engines. Sea level and altitude performance

tests would demonstrate nozzle system performance over the flight spectrum, while a static acoustic test would verify the low-noise characteristics.

4.2.3 Duct Burner Technology

The VSCE duct burner represents a significant extension in the state-of-the-art of combustor systems. Like the main combustor, the duct burner is subject to stringent operating requirements such as high performance and low emissions as well as the demands for long commercial life. Also, engine stability considerations require smooth light off and fuel flow modulation over a broad operating range.

Developing key duct burner technologies will build on the work accomplished in the current programs listed in Figure 4.2-3.

The two main duct burner-related programs currently in progress at Pratt & Whitney Aircraft are the Duct Burner Experimental Rig Program and the VCE Testbed Program, both of which are under NASA sponsorship. In the experimental rig program, the overall objective is to assess the aerothermal and mechanical capabilities of the three-stage Vorbix system in a segment rig. This enables refinement of the design and also increases the confidence level at high temperatures and fuel/air ratios before the configuration is evaluated in the VCE Testbed Program. Areas being investigated include emissions control, performance, stability, safety characteristics, and identification and correction of deficiencies.

As discussed in the previous section, the VCE Testbed Program will provide the first opportunity to demonstrate the interaction and operating characteristics of the duct burner and coannular nozzle in large scale. The series of tests planned for this program will acquire data pertaining to duct burner overall aerothermal performance, emissions, combustion noise, ignition and blow out. Test data will provide a basis to implement design improvements.

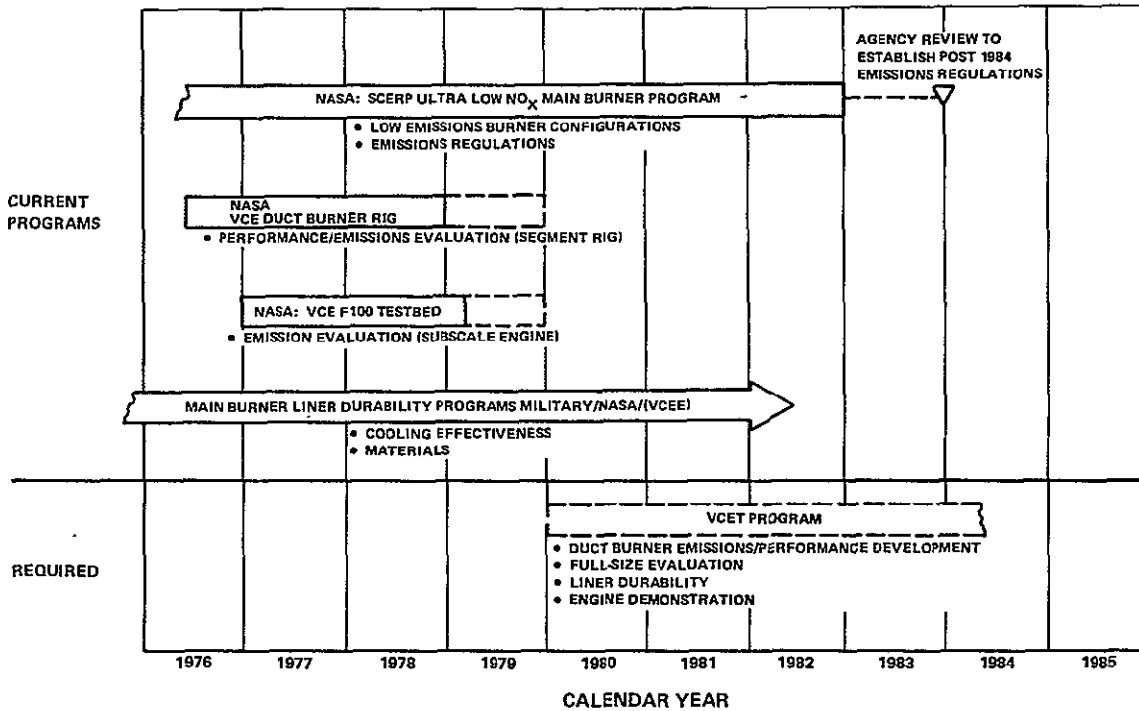

Figure 4.2-3 VCE Duct Burner Technologies – The combination of current programs with the VCE Programs will provide the technology level to demonstrate a viable duct burner system.

Along with these programs, several additional technology programs are recommended in order to meet the VSCE goals. These duct burner programs are listed in Table 4.2-III and summarized below.

- Thermal Effectiveness Rig (Screening)
- VCE Sector Rig or Testbed Engine Evaluation
- Low Cycle Fatigue Rig

TABLE 4.2-III

REQUIRED DUCT BURNER PROGRAMS

- Performance/Emissions Testing
 - VCE Duct Burner Rig Tests
 - Follow-on VCE F100/Testbed Engine Tests
 - Fan Duct Diffuser Rig
 - Flight Engine Size Duct Burner Sector Rig
- Liner Durability Program
 - Study/Screening of Heat-Transfer Concepts/Materials

- Engine Demonstrator

Fan Duct Diffuser Rig Testing – Locating the duct burner in close proximity to the fan to improve engine packaging introduces stability and flow interaction concerns. Moreover, this portion of the fan duct is a relatively high area ratio diffuser, compared to main combustor diffusers, and diffusion must be accomplished in a short length and with high efficiency.

In the Fan Duct Diffuser Program, diffuser geometries, scaled to one-third or one-half size, would be experimentally tested in a full

annular, cold flow rig. The rig would incorporate a simulated front end of the duct burner and have the capability to approximate fan discharge conditions to obtain pressure distribution data at the duct burner inlet. Testing during a later stage of the program includes evaluating front end sections with simulated service and support struts. Data obtained from this work would also be used to refine such areas as the burner hood contour for compatibility with the diffuser exit flow.

VCE Duct Burner Rig Testing – The proposed Duct Burner Segment Rig Program would follow the same format as the current Duct Burner Experimental Rig Program in that testing would be conducted in the same segment rig. Results from the preceding parametric diffuser study would be used to demonstrate the influence of an aerodynamically-refined duct burner inlet on overall system performance and emissions.

Follow-On VCE Testbed Testing – The follow-on VCE testbed effort would be directed towards further development of the duct burner component. Modifications to the duct burner would concentrate on reducing the pressure loss and length, as well as developing a simpler system capable of meeting the environmental requirements. The effects of operating environment such as the effects of inlet flow circumferential distortion caused by diffuser struts would also be investigated.

Flight Engine Size Duct Burner Sector Rig Testing – The engine demonstrator will be recommended as a subscale engine with an airflow capacity of 113 - 136 kg/sec (250 - 300 lbs/sec) rather than a flight engine size with an airflow capacity of 272 - 408 kg/sec (600 - 900 lbs/sec). However, unlike other engine components, combustor components do not scale proportionately because the length is expected to remain relatively constant over a large range of flow areas and annulus heights. Consequently, the duct burner for a flight size engine could have as much as 40 percent less liner area to cool in comparison to the scaled

size. This reduction in cooling requirement would allow more air for emissions control and performance enhancement.

Therefore, in the Large Size Sector Rig Program, the objective would be to demonstrate scaling effects relative to the smaller segment rig. Although performance should improve, some aspects may not directly scale, thereby requiring added development or substantiation. Facility airflow limitations preclude the use of a full annular rig so a sector rig would be used in this test. Diffuser exit conditions, including wakes, observed during the Fan Duct Diffuser Rig Program would be simulated at the inlet to the sector rig.

Liner Durability Program – This durability improvement program parallels the effort for the main combustor. The scope of work entails an initial analytical study of cooling and structural concepts as well as a survey of materials. Following this screening, rig testing would be performed to assess the thermal effectiveness of the different concepts. Low cycle fatigue testing would also be conducted with selected concepts to determine life characteristics.

Demonstrator Testing – The engine demonstrator test serves to demonstrate and evaluate the collective interaction of the different duct burner concepts in a full engine environment. Testing would be performed both at sea level and altitude to acquire data on performance, noise, emissions, and durability.

4.2.4 High Temperature Validation

Technologies related to the engine hot section, the turbines and the main combustor, are of primary importance because of the stringent operating requirements in combination with the demands for long commercial life. The inverse throttle schedule and the anticipated high operating time in the supersonic cruise mode indicate the engine will accumulate substantially more time operating at maximum combustor exit temperatures

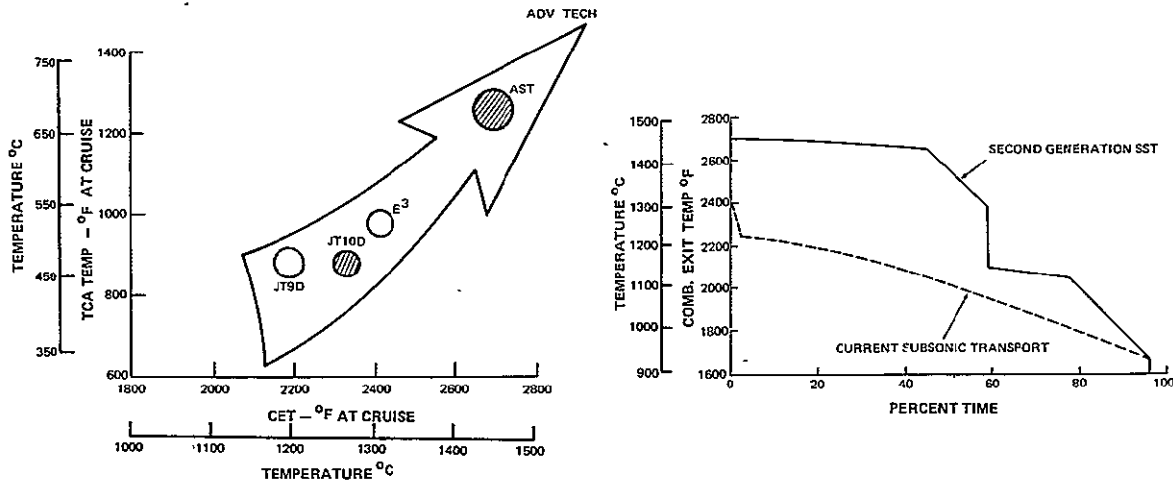

Figure 4.2-4 Projected Hot Section Temperature - Second generation supersonic transport engines operate at higher combustor exit temperatures as well as use higher temperature air as coolant.

compared to current subsonic transport engines. This trend is clearly evident in Figure 4.2.4. Also indicated in this figure are the requirements to utilize higher temperature coolant flow as a result of the high ram inlet temperature during supersonic cruise.

The problem of high combustor exit temperatures as well as coolant air temperatures is further amplified by the requirement to lower the percentage of turbine cooling flow to improve component and cycle performance. As indicated by the trend in Figure 4.2-5, this results in a requirement for more turbine cooling technology over current and anticipated advanced subsonic engines.

In addition, performance and engine weight improvements necessitate operation at high turbine blade stress levels. Figure 4.2-6 shows that a future supersonic engine operates at maximum blade stress levels for more than 50 percent of the total flight time compared to subsonic engines which only operate at peak stresses during takeoff.

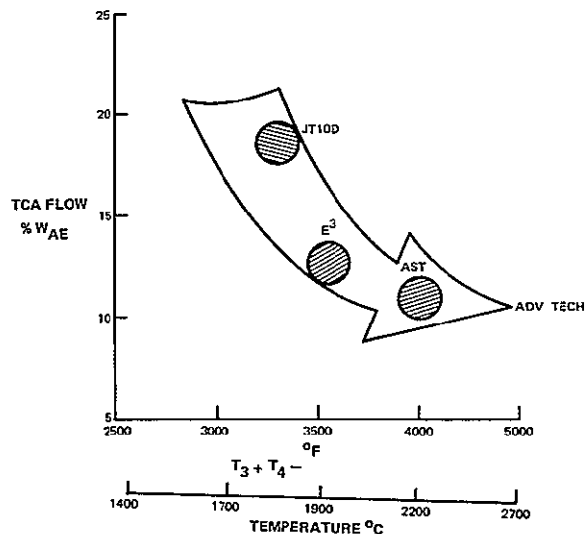

Figure 4.2-5 Turbine Cooling Air Turbine - Higher temperatures must be endured with a decrease in cooling in order to improve system efficiency.

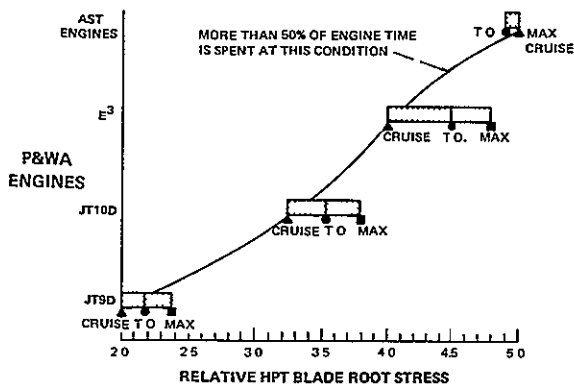

Figure 4.2-6 High-Pressure Turbine Blade Stress at Critical Operating Points – Commensurate with the higher speeds, pressures and temperatures, supersonic engines operate at a substantially higher blade stress for a longer period of time.

Earlier studies of future supersonic engine concepts have also emphasized the importance of high temperature technology on cycle performance. A nearer term technology variant of the VSCE-502B was defined and designated VSCE-511. Although this nearer term engine still retains significant technology advancements, the performance penalties over the VSCE-502B, shown in Figure 4.2-7, are large. Figure 4.2-7 shows the impact of the level of technology in a step-by-step manner. For each component technology change, the cycle bypass was re-optimized and the change in specific fuel consumption assessed. As shown in this figure, high temperature technology is the dominant contributor to the VSCE-502B performance goals.

4.2.4.1 High Temperature Validation – Turbine

The advanced technology turbine component introduces various challenges in the areas of improved aerodynamics, materials, and cooling management. Developing the technologies

in these areas would build upon ongoing advanced technology programs at Pratt & Whitney Aircraft. Specific programs and their time frames are presented in Figure 4.2-8. The current programs shown in this figure, the Energy Efficient Engine Program, Advanced Turbine Engine Gas Generator (ATEGG) Program and proposed Joint Technology Demonstrator Engine (JTDE) Program, provide a technology base to build upon for meeting these requirements.

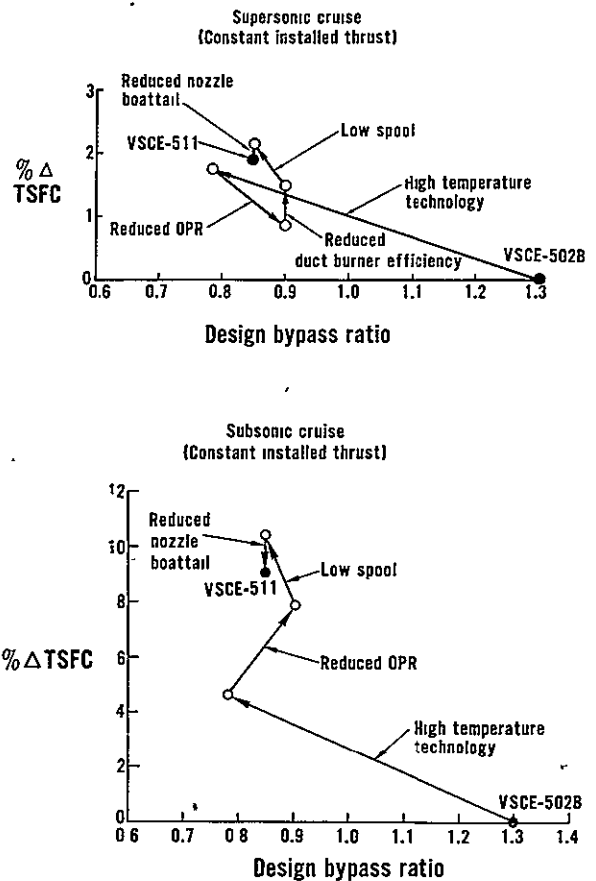

Figure 4.2-7 Importance of High Temperature Technology on Engine Performance – Improvements in high temperature technology translate into appreciable gains in fuel consumption when compared to other factors identified.

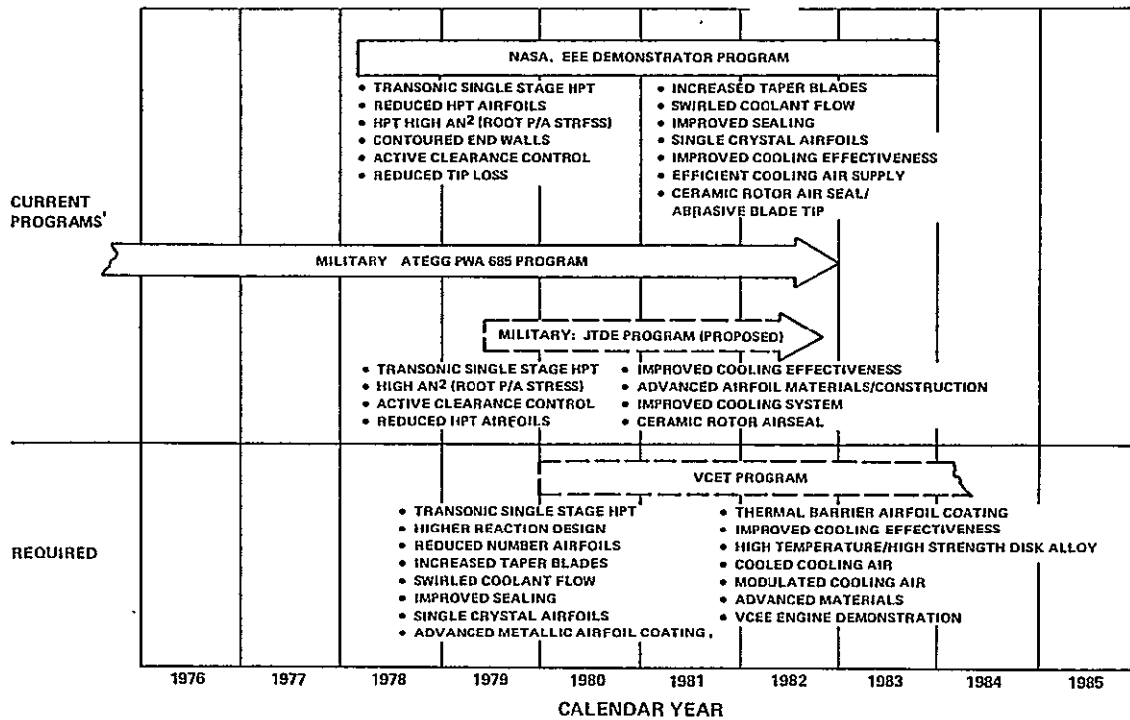

Figure 4.2-8 Turbine Technologies - The different turbine technologies being experimentally investigated under the current programs provide an essential technology base for meeting turbine requirements.

The NASA-sponsored Energy Efficient Engine Program is directed, in part, towards demonstrating turbine technologies for a subsonic engine with a high compressor pressure ratio, moderately high combustor exit temperature, and high turbine expansion ratio. Turbine concepts that will be investigated include near-term single crystal airfoils, advanced cooling techniques, high efficiency single-stage turbine, and a high stress/low solidity turbine configuration. Active clearance control concepts will also be evaluated as part of this program.

The ATEGG and proposed JTDE Programs are both military sponsored. One objective of the Air Force sponsored ATEGG program is to evaluate an advanced high-pressure turbine developed under the Navy-Sponsored NA HPT (Navy Advanced High-Pressure Turbine) Programs. This turbine features materials and construction that are capable of operating at high temperatures and high loadings. The JTDE

Program, as planned, would combine successful elements of the Advanced Propulsion Subsystem Integration (APSI) Program, which is primarily directed at developing fan subsystem technology, with the ATEGG core to provide an advanced demonstrator engine.

High-Pressure Turbine Programs

To achieve the advanced supersonic high-pressure turbine requirements, additional technology programs are necessary. The recommended programs are identified in Table 4.2-IV. As indicated, programs for the high-pressure turbine are arranged into two main categories. These include experimental test programs to demonstrate aerodynamic and thermodynamic concepts and programs for materials development. The overall effort would culminate during the test of the turbine in a core or demonstrator engine. The programs listed in Table 4.2-IV are described briefly in the following paragraphs.

TABLE 4.2-IV
REQUIRED HIGH-PRESSURE
TURBINE PROGRAMS

- Experimental Test Programs
 - Turbine Cooling Program
 - Studies/Screening
 - Cascades (Aero and Heat Transfer)
 - Heat Exchanger Program
 - Aero Cascades
 - Uncooled Rig Test
 - Cooled Rig Test
 - Demonstrator Hardware
 - Leakage Testing
 - Core/Engine Demonstrator Test
 - Performance/Duability Demonstration In Engine Environment
- Materials Programs
 - High Temperature/High Strength Disk
 - Thermal Barrier Airfoil Coating
 - Advanced Metallic Airfoil Coating
 - Advanced Single Crystal Blade and Vane Alloys
 - High Temperature Case Alloy
 - Monolithic Ceramic Vane*
 - Directionally-Solidified Eutectic Blade*

*Far Term Technology

Turbine Cooling Program - The object of the Turbine Cooling Program would be to develop key heat transfer technology to enable effective cooling of high velocity regions such as the airfoil suction surface with a minimum of cooling air. Various airfoil cooling techniques would be screened analytically and selected approaches tested experimentally in aerodynamic and heat transfer cascades to assess cooling effectiveness and aerodynamic performance.

The type of variables considered in this study include cooling system design as well as airfoil

materials. This encompasses transpiration and film cooling techniques as well as wafer and three-piece blade construction concepts.

Heat Exchanger Program - During supersonic cruise, the temperature of the compressor discharge flow may be too high for use as turbine coolant and thereby may require precooling to an acceptable level. The results of preliminary heat exchanger studies using a fan air cooling system indicate that this may be desirable if fan stream pressure losses do not exceed 3 percent.

A program to develop a heat exchanger system would center on investigating sources of cooling such as fan air or possibly fuel and the method of mechanically routing the air from the compressor to the heat exchanger and finally to the turbine section. Rig testing would be also conducted to determine heat exchanger effectiveness and pressure loss.

Ducting turbine coolant flow to a heat exchanger introduces the possibility of modulating the coolant flow rate at different operating conditions. Reducing the coolant flow at low temperature operating conditions could decrease subsonic fuel consumption and thereby improve operating economics. This possibility would be studied as part of the Heat Exchanger Program.

Aerodynamic Cascades - Prior to the detailed design of the high-pressure turbine and fabrication of complex air-cooled airfoils, a series of cascade tests would be conducted to optimize airfoil aerodynamic performance. Relatively inexpensive vanes and blades would be designed, fabricated and tested in this program. The transonic airfoils, endwall contours, and low solidity concepts identified during the preliminary design effort would be evaluated.

Uncooled Rig Test - Concurrent with the cascade studies, testing would be performed in an uncooled high-pressure turbine rig to verify turbine performance characteristics. The

scope of work involves experimental testing of two airfoil configurations. The first configuration would be a design initiated early in the program and based on selected design parameters identified from a preliminary analysis. This provides early verification of the selected design concepts. The second configuration would draw from the cascade development work described in the preceding paragraph and verify the final uncooled aerodynamic design. Rig testing would be directed at evaluating airfoil performance in a three-dimensional cascade as well as first-stage turbine performance in the rotating rig.

Cooled Rig Test - The work in this program would be aimed at integrating aerodynamic and thermodynamic technologies developed under the previous supporting turbine programs into a high efficiency subsystem. The rig would as closely as possible simulate the aerodynamic environment of the turbine, and for reduced cost, the rig would be designed using hardware that can be transferred to the core/engine demonstrator. Use of the cooled rig provides expanded instrumentation capability not available in an engine to maximize data return and provide verification of turbine technologies prior to an engine test.

Testing would concentrate on demonstrating the efficiency of the total turbine system. Specifically, turbine vane and blade cooling and supply systems would be demonstrated along with the airfoil aerodynamic designs to show the impact of cooling on performance. The turbine design would include configuration modifications to accommodate coolant flow, thermal barrier coatings, and controlled leakage concepts.

An additional supporting program in the development of the high-pressure turbine design is the investigation and synthesis of minimum leakage designs. A series of leakage tests would be performed to verify the low leakage design.

Core/Engine Demonstrator Tests - A core demonstrator performance test would verify the interactive engine operating characteristics on turbine performance at simulated full engine conditions. A limited demonstration of turbine durability would be possible by conducting an accelerated high temperature test with extensive heat transfer instrumentation. In addition to durability, this test would provide an indication of short term deterioration of the turbine. Detailed turbine performance could be measured during core testing, and, through the use of advanced instrumentation techniques, heat transfer effectiveness would be assessed.

Evaluating the high-pressure turbine in a full engine demonstrator would further add confidence to the technologies demonstrated in the core tests. Engine testing would continue to assess performance and durability in a total engine environment over the flight spectrum.

High Temperature/High Strength Disk Alloy - The turbine in the advanced supersonic propulsion system will require an improved disk material. Such a material is anticipated to require an additional 28°C (50°F) capability over the MERL 76 disk alloy used in the EEE demonstrator, while maintaining tensile and low cycle fatigue properties equal to current advanced alloys. Meeting this requirement is expected to be best accomplished with a dual property disk material having a bi-alloy joint. A program for developing this material would consist of the following elements: (1) identifying material/process combinations that meet strength and low cycle fatigue goals, (2) establishing manufacturing procedures to accurately position the bi-alloy joint and demonstrate property goals in large scale consolidations, and (3) conducting component demonstration testing, including spin/burst and spin/fatigue evaluations.

Thermal Barrier Coating - The use of a thermal barrier coating on turbine airfoils could reduce metal surface temperature by as much as 167°C (300°F), thus permitting a reduction in the amount of coolant to the airfoils. Work in this program would center on developing a process for applying high-performance ceramic coatings on turbine airfoils, characterization of coating properties, and engine demonstration of the coating performance, benefits and durability.

Advanced Metallic Airfoil Coating - A thermal barrier coating by itself will not provide adequate corrosion-oxidation resistance for the basic airfoil alloy. Therefore, a metallic coating layer is still required on the airfoil alloy under the thermal barrier coating. The objective of this program would be to develop an improved corrosion-oxidation resistant overlay coating that utilizes metal matrix/oxide-dispersion concepts. Advantages with this type of coating system include improved oxide scale adhesion and reduced thermal expansion mismatch between the alloy and coating.

Advanced Single Crystal Vane/Blade Alloys - Advanced single crystal alloys offer the potential of increasing turbine vane and blade temperature capability 97°C (175°F) and 56°C (100°F), respectively. This temperature capability is appreciably higher than the near-term single crystal alloy being evaluated under the Energy Efficient Engine Program.

To acquire this technology, an alloy development effort would be initiated in order to identify alloy compositions capable of meeting the temperature goals. Following this work, the program would be directed towards material and processing characterization, and finally verification of the alloy through experimental rig and engine testing.

High Temperature Case Alloy - The intent of this program would be to develop and verify a turbine case alloy with a temperature capability of up to 56°C (100°F) over conven-

tional turbine case materials. Work would involve alloy optimization, process screening and selection, joining studies, material testing and fabrication development, and component fabrication and evaluation.

Monolithic Ceramic Turbine Vane - In comparison to conventional metal turbine vanes, use of a ceramic first-stage vane could provide substantial gains in temperature potential by as much as 167 to 278°C (300 to 500°F). However, since this concept presents unique complexities along with a high technical risk factor, it is considered a far term technology and not recommended for early testing in a demonstrator. Utilizing this technology in a subsequent generation of the demonstrator program after extensive parallel development appears more practical.

Basically, a Ceramic Vane Technology Program would consist of many different laboratory tests to select the most attractive composition and determine material properties, particularly time dependent properties such as creep, fatigue and impact resistance. In addition, the airfoil design would be experimentally evaluated to establish life characteristics, effects of localized premature failure, optimum material, and method of attachment. Finally, a full scale set of vanes would be fabricated and subjected to rig and engine testing.

Directionally-Solidified Eutectic Blade - A directionally-solidified eutectic blade alloy offers a 111°C (200°F) advantage over current turbine blade alloys. For developing this technology, the program would optimize composition and the casting processes required to cast airfoils, characterize materials and processes to acquire design data, and fabricate sample airfoils for laboratory, rig and engine evaluation.

Like the ceramic turbine vane, however, this technology is considered far term and not practical for incorporation in the initial demonstrator design.

Low-Pressure Turbine Programs

The recommended technology programs to meet low-pressure turbine requirements are listed in Table 4.2-V. Work in this area would be mainly directed towards improving component and subsystem aerodynamic efficiency. The different programs are described briefly in the following paragraphs.

**TABLE 4.2-V
REQUIRED LOW-PRESSURE
TURBINE PROGRAMS**

- Aero Cascades
- Large Diameter Rotating Rig
- LPT Component Aero Development
 - Full Scale Cascades
 - Uncooled Rig Test
- Exit Guide Vane Tests
- LPT Rig Test
- Engine Demonstrator

Aerodynamic Cascade Testing - The aerodynamic properties of low-pressure turbine airfoils would be defined and investigated experimentally in a large scale, cold flow, plane cascade. Cascade testing would assess the effects of low throughflow velocity ratio (C_X/U), high endwall divergence, low solidity, and highly-loaded airfoil tip sections. Several design configurations for each concept would be evaluated to determine an optimum design for further testing.

Large Diameter Rotating Rig - Following static, cold flow cascade testing, the selected airfoil geometric configuration would be tested in a large scale, rotating rig. As a design tool, this cold flow rig allows visual observation of dynamic aeromechanical phenomena. Testing

would permit the analysis of airfoil interactive performance effects, radial pressure gradients and distributions, blade tip clearances, and disk front air effects.

Component Aerodynamic Development - As a parallel program to the large scale, plane cascade and rotating rig programs, a series of cascade tests would be performed with the final size low-pressure turbine component to optimize performance. This would be followed by testing in a cold flow, rotating rig which would provide similar data as the parallel high-pressure turbine cold flow rotating rig.

Exit Guide Vane Development - Cycle matching during different augmented and nonaugmented flight modes results in large variations in low-pressure turbine expansion ratio. For example, the calculated VSCE-502B low-pressure turbine expansion ratio at supersonic cruise is 3.6:1 and varies to 3.4:1 at takeoff and 2.9:1 at climb. The impact of this variation in relation to the exit guide vanes is a large change in incidence angle which adversely affects the aerodynamic efficiency of a fixed-geometry airfoil.

The scope of work in this program would involve studying methods for accepting large degrees of incidence variation without compromising performance. This study would address the use of a variable leading edge or supercritical airfoils. A series of cascade tests would follow with the objective of optimizing and verifying the selected design approach.

Low-Pressure Turbine Rig Test - Prior to demonstrator engine testing, the low-pressure turbine subsystem would be evaluated in a rig that is capable of closely approximating the aerodynamic operating environment of the engine. The rig would be designed to use engine hardware for reduced overall program cost.

In this rig test program, the low-pressure turbine module would be tested to demonstrate the integrated effects of the various aerodynamic and thermodynamic technologies developed in both high-pressure and low-pressure turbine programs. Materials and cooling concepts used in the low-pressure turbine would be extracted from work accomplished in the high-pressure turbine programs.

Engine Demonstrator Test - Engine demonstrator testing would verify the performance of the low-pressure turbine as an integrated system within the engine. Performance would be demonstrated at operating conditions anticipated for a flight engine. Also, limited durability testing would be performed.

4.2.4.2 High Temperature Validation – Main Combustor

The principal requirements for the main combustor in a VCE system are durability and low exhaust emissions/high chemical efficiency. As

indicated earlier, the main combustor is subjected to an unusually severe thermal environment, particularly with the inverse throttle schedule in which the combustor operates at maximum inlet and exit temperatures for sustained periods instead of just at the short term takeoff condition as for subsonic propulsion systems. The problem of combustor durability is further compounded by the requirement to minimize cooling flow to the liners in order to provide dilution air to control exhaust emissions.

Programs to acquire the technology for supersonic cruise applications would build on the foundation provided by the current work being conducted by Pratt & Whitney Aircraft in the various programs shown in Figure 4.2-9.

For example, the NASA-sponsored Stratospheric Cruise Emissions Reduction Program (SCERP) is investigating basic combustor technology to determine emissions reduction potential. Information acquired from this effort will also provide a basis to establish post

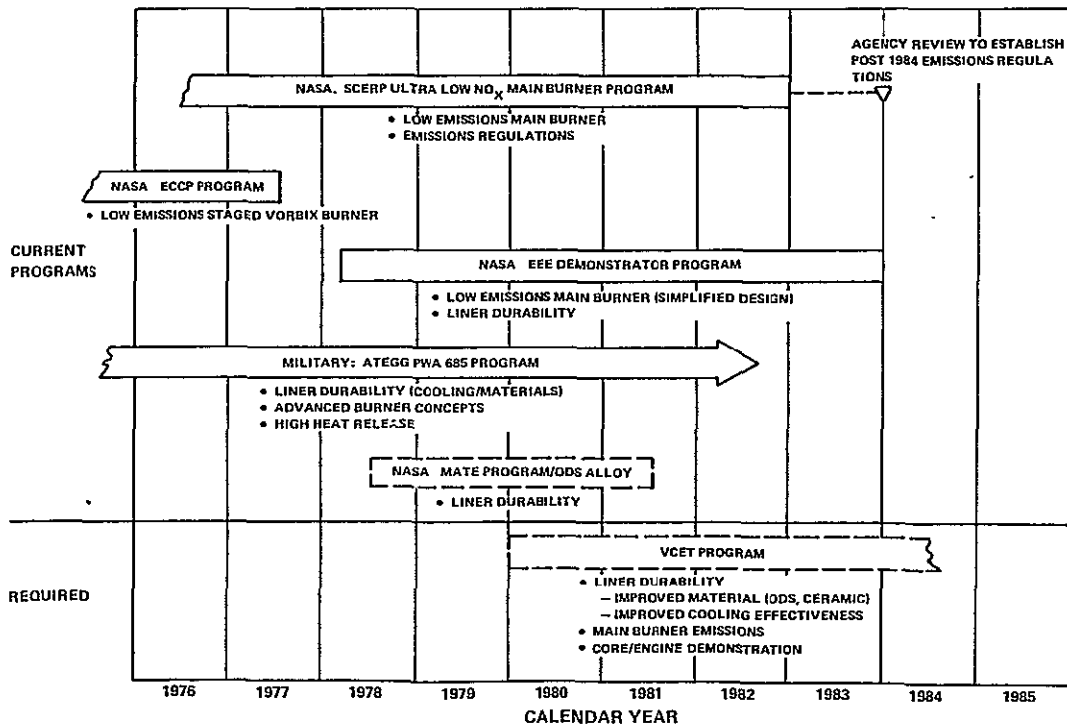

Figure 4.2-9 Main Combustor Technologies – Essential main combustor technologies will build on the foundation provided by ongoing advanced technology programs at Pratt & Whitney Aircraft.

1984 emissions regulations. The recently completed Experimental Clean Combustor Program (ECCP) successfully demonstrated the staged-Vorbix (vortex burning and mixing) combustor concept during an experimental engine test program. As part of the Energy Efficient Engine Program, this technology will be further developed by demonstrating a simplified, staged low-emissions combustor as well as addressing durability. Under the current Air Force-sponsored ATEGG Program, advanced liner cooling techniques and fabrication methods are being explored. Finally, the proposed Materials for Advanced Turbine Engines (MATE) Program is directed towards developing an oxide-dispersion strengthened alloy to permit high temperature operation with improved durability.

In addition to these programs, several additional programs are recommended to meet main combustor technology requirements. The recommended programs are listed in Table 4.2-VI and summarized in the following paragraphs.

TABLE 4.2-VI

REQUIRED MAIN COMBUSTOR PROGRAMS

- Liner Durability
 - Study/Screening of Heat-Transfer Concepts/Materials
 - Thermal Effectiveness Rig (Screening)
 - Cyclic Fatigue Rig
- Sector Rig
 - Substantiate Liner Durability
 - Develop Emissions/Performance
- Full Annular Rig
 - Demonstrator Hardware
 - Verify Performance
- Materials
 - Ceramic Wall Burner Liner (Far Term Technology)

- Core Test
 - Performance/Durability/Emissions Demonstration In Simulated Engine Environment
- Engine Demonstrator Test
 - Performance/Durability/Emissions Demonstration In Engine Environment

Liner Durability Program – Differences in cycle and mode of operation are expected to affect the combustor liner design criteria wherein high temperature life could become more significant relative to cyclic life. The work on liner durability would focus on optimizing the combustor liner aerothermal-mechanical configuration to ensure improved durability before initiating final design or fabrication of the component. The program would first involve an analytical design study to assess the merits of different materials, construction techniques and cooling concepts. Because of the unique flight cycle, some unconventional concepts might be identified that would not normally be considered for more conventional subsonic engines. Liner cooling approaches showing the most potential would be rig tested to demonstrate thermal effectiveness. Subsequent tests would be directed towards a cyclic fatigue evaluation of the most effective cooling concepts with different liner materials.

Ceramic Wall Liner – The use of ceramics for the combustor liner is attractive in terms of durability, increased temperature capability (up to 278°C (500°F)) and lower cooling requirements. Ceramic technology is viewed as a far-term technology, requiring extensive development before approaching a state of technical readiness. Therefore, this concept is not recommended for inclusion in early demonstrator testing. Utilizing this technology in a subsequent generation of a demonstrator, after extensive parallel development, appears more practical.

A program to develop ceramic liner technology would consist of a comprehensive series of experimental tests, ranging from materials specimen testing to rig evaluation of the prototype design. In general, the scope of work would address materials/mechanical design selection and optimization, fabrication, and extensive testing to determine performance and durability characteristics.

Main Combustor Sector Rig – With a main combustor sector rig, a section of the combustor mechanical configuration would be tested at realistic pressure and temperature levels for performance/emissions development as well as evaluating the cooling effectiveness of the most promising concepts identified in the Liner Durability Program. The capability of simulating engine conditions and the relatively inexpensive hardware utilized to facilitate modifications makes this an invaluable development tool to refine the emissions and performance potential of the main combustor. It is anticipated that the emissions technology required for the main combustor would be generated under other programs such as the Energy Efficient Engine Programs, for example, and it would be only necessary to refine this technology for the supersonic propulsion system.

Full Annular Combustor Rig – A full annular combustor rig test program, which is comprised of testing the demonstrator engine main combustor, would refine key performance parameters such as radial temperature distribution and exit pattern factor before the system is installed in a demonstrator. Actual engine combustor hardware would be used for testing, except for the combustor liners which could be of a relatively inexpensive construction to facilitate minor adjustments. Liner cooling air flow would be identical to the demonstrator main combustor design, and dilution hole patterns could be easily revised and optimized before the patterns are installed in the final combustor liners. Rig pressure limitations would preclude emissions evaluation, however, final combustor performance

would be refined and assessed, and safety considerations such as blowout and lightoff would be determined.

4.2.5 Variable Geometry Turbomachinery Technology

Variable geometry components are a key requirement for stable and efficient operation of a propulsion system over the combined subsonic/supersonic flight spectrum for a second-generation supersonic transport. The variable geometry components are the inlet, fan and compressor as well as the coannular exhaust nozzle discussed in Section 4.2.2.

The flight spectrum of a second-generation supersonic transport dictates use of a variable geometry inlet for efficient diffusion of the inlet flow with the capability of adjusting the flow schedule during off-design operation for improved engine/inlet airflow matching. The capability of optimum engine/inlet airflow matching is the subject of the integration studies which would be completed by the airframe companies.

Variability in both the fan and compressor components is mandatory to avoid compromises in performance. The fan operates at a different pressure ratio and corrected airflow during supersonic cruise than at subsonic cruise, as illustrated in Figure 4.2-10. To provide maximum efficiency and stable operation at both

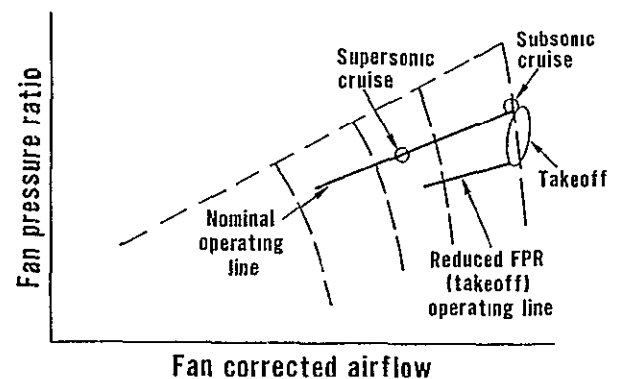

Figure 4.2-10 Typical VSCE Fan Map - As shown, the fan operates at diverse conditions corresponding to the different modes of flight.

flight conditions, variable geometry in the fan inlet guide vanes and exit guide vanes is necessary. The same requirement for efficient and stable operation over a broad range of operating conditions applies to the compressor where variable geometry stators in selected stages will be required.

Current programs aimed at developing variable geometry component technology and fan/compressor technology in general are shown with their respective time frames in Figure 4.2-11. The principal programs providing the technology base in this area are the Energy Efficient Engine Program, the ATEGG Program, and the APSI Program. The programs listed in Figure 4.2-11 do not reflect work in the area of inlet technology. At present, various inlet concepts are under study by the SCAR airframe contractors and engine/inlet integration effects are also being addressed by Pratt & Whitney Aircraft and the airframe contractors.

The Energy Efficient Engine Program would furnish the basic aerodynamic technology for

the supersonic technology fan and high-pressure compressor. Although the EEE fan is a fixed-geometry, single-stage design, the fundamental aerodynamic advancements demonstrated in the EEE would be applicable to the variable, multistage advanced fan. The hollow fan blade concept that will be evaluated as part of the EEE Program would provide a backup approach to the use of composite material airfoils planned for the supersonic propulsion system. Other compressor concepts that will be studied in depth include supercritical stators, active clearance control, seals and high speed bearing technology.

Work performed in the ATEGG, proposed JTDE, APSI and Composite Fan Blade Programs would also contribute to the technology base. Although high-through-flow technology has not been identified as a requirement for the supersonic propulsion system at this time, the ATEGG high-through-flow compressor has successfully demonstrated advanced aerodynamic and mechanical

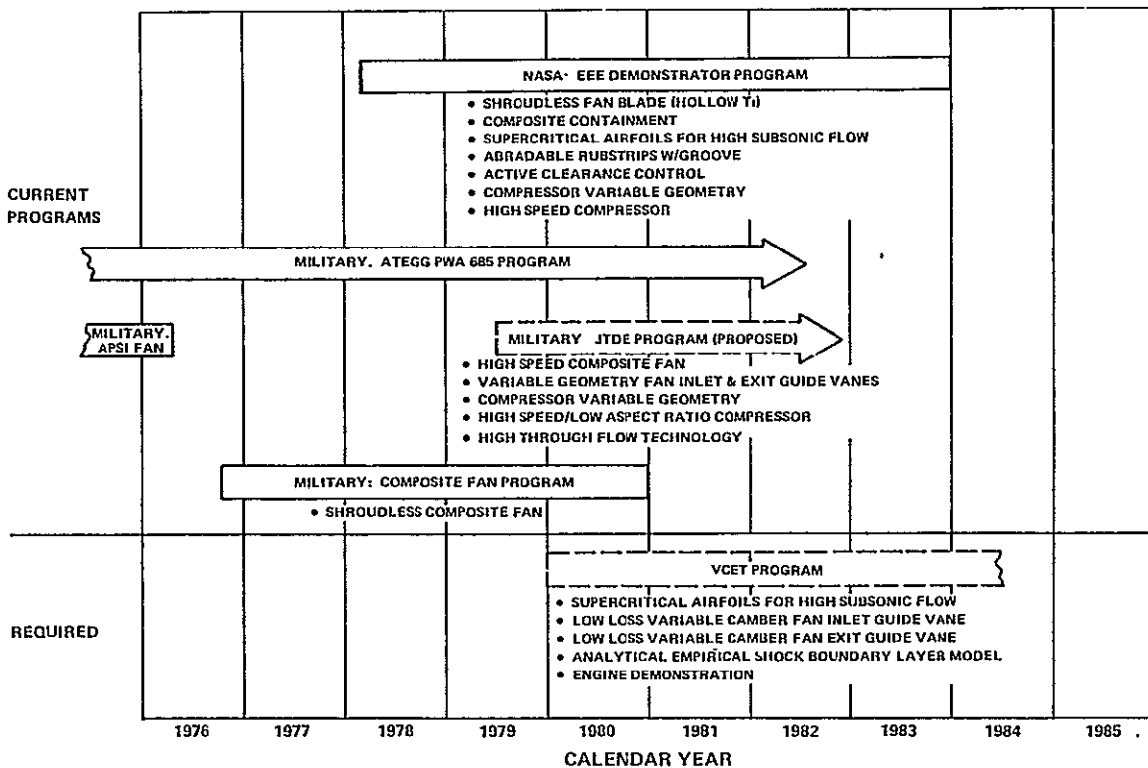

Figure 4.2-11 Fan and Compressor Technologies – Work accomplished under the Energy Efficient Engine, APSI, ATEGG, and JTDE programs will substantially benefit development of the advanced fan and compressor component technologies.

design concepts within the context of a high speed, variable geometry compressor. Work completed under the Air Force-sponsored APSI Program, demonstrated a high tip speed, multistage fan configuration with composite material blades and variable geometry stators. Continued development of composite fan blade technology is being pursued in the Composite Fan Program, which is also under Air Force-sponsorship. Demonstrating these advanced concepts in an engine environment will be accomplished in the proposed JTDE Program.

Additional programs are recommended to adapt the above technologies to the supersonic propulsion system as well as to develop the aerodynamics to meet performance goals. The programs are listed in Table 4.2-VII and a brief description of the work and program content is presented in the following paragraphs.

TABLE 4.2-VII

REQUIRED FAN/COMPRESSOR PROGRAMS

- Fan Programs
 - Variable Inlet and Exit Guide Vane Cascades
 - Large Diameter Rotating Rig
 - Scaled Fan Single-Stage Rig
 - Fan Rig
- Compressor Programs
 - High-Pressure Compressor Rig
 - Core Engine Test
- Demonstrator
 - Demonstrate Variable Cycle/ Variable Geometry Operation

Variable Fan Inlet and Exit Guide Vane Cascade Testing – Variable geometry inlet guide vanes must operate with minimum wakes to reduce disk and blade weight. Also, variable vanes in both the inlet and exit position must be designed to minimize aerodynamic losses.

In the Variable Guide Vane Cascade Program, different concepts such as variable leading/trailing edge flaps, multicomponent cascades, tandem cascades, and trailing edge blowing would be evaluated. The use of supercritical-designed airfoils would be also studied. During the final phase of the program, several cascades would be designed and tested in a high speed planar cascade to determine the optimum scheme.

Large Diameter Rotating Rig – The work in the Large Diameter Rotating Rig Program would be directed towards providing an understanding of the mechanisms and characteristics of blade tip leakage. This large scale rig permits visual observation of aeromechanical phenomena to assist in the interpretation and analysis of results. Concepts such as tip treatment would be evaluated to determine stability, tip clearance effects, radial pressure distribution and other factors involved with tip loss generation.

Scaled Fan, Single-Stage Rig Test Program – The work defined for the Scaled Fan Test Program would provide a greater understanding of fan losses and loss distribution. This would be accomplished through combined analytical studies and cascade testing, followed by rig testing using an existing subscale, single-stage fan rig. Advanced blading concepts and variable geometry vane concepts would be evaluated using advanced instrumentation techniques such as a laser doppler velocimeter to measure shock and boundary layer interaction. Results of the preceding Variable Guide

Vane Program and Large Diameter Rotating Rig Program would be verified and the concepts refined as a part of the Scaled Fan Test Program.

Because the Scaled Fan Test Program is a three year effort, it is recommended that it be conducted in parallel with the fan design and component rig testing. The results of this technology program would then be available for a second-generation fan.

Fan Rig Test – The Fan Rig Component Test Program would provide collective verification of the advanced technologies in a multistage component prior to incorporation into the demonstrator engine. These tests would furnish baseline fan system performance information and identify areas for possible refinement. Testing the fan in a component rig affords test flexibility and use of instrumentation not available or practical in an engine configuration, thus maximizing data return. The fan rig would be designed using engine hardware that could be transferred to the subscale demonstrator engine.

High-Pressure Compressor Rig Test – Aerodynamic and mechanical concepts and technologies developed under the Energy Efficient Engine and ATEGG Programs would be integrated into the design of the high-pressure compressor for the demonstrator engine. Evaluating this compressor in a component rig offers added test flexibility and instrumentation capability to verify the compressor component prior to an engine test and maximizes data return. To reduce cost, the rig would be designed using engine hardware.

Core/Engine Demonstrator Tests – The core and engine demonstrator tests are the final steps in verifying fan and high-pressure compressor technology. A core demonstrator

performance test would demonstrate the high-pressure compressor in a simulated engine operating environment. The engine demonstrator test would demonstrate the interactive performance of the fan and compressor systems throughout the engine operating range. This test program would also define and evaluate the effects between the fan and the diffuser and duct burner. As part of the demonstrator program, a static acoustic test would assess fan noise characteristics.

4.2.6 Integrated Electronic Control Technology

The control system for a VSCE will be more complex than systems for subsonic commercial aircraft. Control of the VSCE variables, which are given in Table 4.2-VIII, necessitates the use of an integrated, full-authority, digital electronic control. The benefits of such a system over present hydromechanical systems are:

- Better control accuracy for improved performance.
- Reduced cost and weight.
- Automatic rating schedules.
- Improved maintainability
- Flexibility to reprogram during development.
- Digital data links to facilitate integration with inlet control, condition monitoring system, and power management system.
- Self testing and self trim capabilities.

TABLE 4.2-VIII

VSCE PROPULSION SYSTEM CONTROL REQUIREMENTS

Variable Geometry Inlet

- Centerbody
- Bleeds
- Bypass Doors

Variable Geometry Fan

Variable Geometry Compressor

Main Combustor Fuel Flow

- Primary
- Secondary

Duct Burner Fuel Flow

- Pilot
- Pilot Secondary
- High Power Stage

Variable Duct Nozzle

Variable Engine Nozzle

Reverser/Ejector System

Starting Bleeds

Active Clearance Control

Programs currently being conducted at Pratt & Whitney Aircraft to develop control system technology are identified in Figure 4.2-12, along with additional technologies required for an advanced supersonic propulsion system. The scope of work covered in the different ongoing programs includes development and flight testing of supervisory and full-authority electronic control systems. The work being performed in the Digital Electronic Engine Control (DEEC) Program is directed at developing a full-authority electronic control for the F100

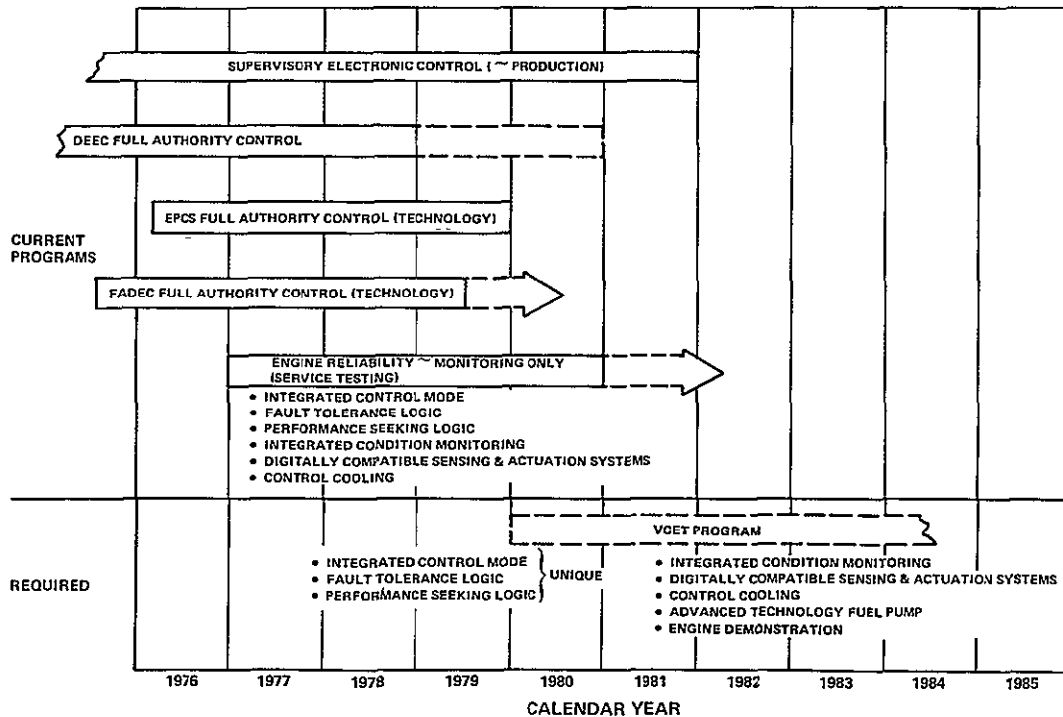

Figure 4.2-12 Controls Technologies – The combined results from ongoing controls programs and additional required programs will provide the technology to demonstrate viability of a full-authority, electronic control for a second-generation supersonic propulsion system.

afterburning engine. The Electronic Propulsion Control System (EPCS) Program is using a JT9D engine as a demonstrator vehicle for static sea level testing of a full-authority electronic control. Following static testing, the control unit will undergo a flight test demonstration. The Full-Authority Digital Electronic Control (FADEC) Program is a Navy-sponsored effort using a F401 afterburning engine as a vehicle to develop technology for electronic control concepts envisioned for the 1980's.

Besides these development programs, a Control Reliability Program will supply in-service reliability data by installing electronic controls which have a monitoring function only on the center engines of Boeing 727 aircraft. Service requirements and overall reliability will be demonstrated in a commercial operating environment.

The unique components and operating modes of the VCE present problems and control functions which are not currently being addressed in the above ongoing programs. Adaptation of these technologies currently under development as well as unique requirements not currently addressed would require additional controls technology programs. These additional programs are listed in Table 4.2-IX and described briefly in the following paragraphs.

TABLE 4.2-IX

REQUIRED CONTROLS PROGRAMS

- Control Requirement Study
- Control Systems Design Study
- Control Interfaces
- Digital Control Preliminary Design
- Digital Control Detailed Design
- Control System Demonstration
- Fuel Pump Demonstrator

Control Requirement Study – Before designing or demonstrating a digital electronic control, the specific requirements must be defined. The control requirement study is required to determine all control logic requirements, controlled variables and sensed variables. Control integration with the airframe/inlet/engine/nozzle would be reviewed as part of this study to ensure efficient operation of the propulsion system in concert with airframe requirements. Other areas that need to be addressed include fault tolerance logic, performance seeking logic and integrated condition monitoring as applicable to the unique operating modes of a VCE. Fault tolerance would provide computer self test, actuator interface failure identification, and sensor failure identification and measurement synthesis.

Control Design Study – The Control Design Study is needed to review the requirements for establishing a conceptual control system design. The design work would emphasize reducing system weight, size and cost, while increasing maintainability and reliability. Some specific areas that need to be studied are electrical/optical interface tradeoffs, possible cooling requirements, fuel pump tradeoffs, high temperature electronic components and general control configurations. Cooling for the electronic circuitry and the fuel pump are particularly unique to the VCE due to the extended periods of time at high temperature caused by the high ram inlet conditions.

Control Interfaces – The degree of sophistication of the electronic control as well as control application necessitates use of advanced interfaces, actuators and sensors to combine low cost and weight with high system reliability. To meet this requirement, hardware development programs are needed to demonstrate the technology readiness of such advanced devices.

Advanced sensing systems necessary for a VCE system include a light-off detector for the duct burner, turbomachinery clearance measurement, a method to measure turbine blade metal temperature, position indicators for variable geometry components, and advanced pressure,

temperature and speed sensors for engine control. Advanced actuators are required to control fuel flow and variable geometry components.

Digital Control Preliminary Design – A preliminary baseline control design would be established using the technology demonstrated under the EPCS and DEEC Programs as a basis for the design. Using the baseline control design, an optimization study is needed to ascertain the best computer approach for a control system. A preliminary control design would be developed using the results from this study which would incorporate advanced technology electronic components.

Digital Control Detailed Design – Assuming the demonstrator engine will utilize a new control rather than a “breadboard” control, a detailed design effort would be initiated after the control system hardware configuration has been selected. Performance and design specifications would be prepared incorporating the results of earlier technology programs and the preliminary control design effort.

Control System Demonstration – Demonstration of the full-authority electronic control system, including the integration of a digital control with advanced interfaces and sensors, would be accomplished as part of the Engine Demonstrator Program. Testing would verify system response, performance and to a limited extent durability. With the exception of a variable geometry inlet, demonstrator testing would verify control of the key VSCE propulsion system variables listed in Table 4.2-VIII. As an alternative to the demonstration of a new control, the critical control functions could also be demonstrated using a “breadboard” control in the engine demonstrator program to reduce program cost.

Fuel Pump Demonstrator – Development of a reliable fuel pump is required for the overall control system development. Current fuel pumps and controls utilize a feedback loop

bypassing fuel to the pump inlet as a means of controlling fuel flow. However, extended time at supersonic cruise would limit recirculation of this fuel since fuel temperatures could exceed safe operating levels. Therefore, a fuel pump that does not require as large or any feedback loop is a requirement.

4.2.7 Flow Inverter Technology

In the event that the Inverted Flow Engine (IFE) is selected over the base Variable-Stream Control Engine (VSCE), the requirement for duct burner technologies, discussed in Section 4.2-3, would be replaced by a requirement for flow inverter technology. The inverted flow engine is essentially a low bypass ratio turbofan matched to yield a higher core stream jet velocity than the duct stream. The flow is then inverted to bring the higher velocity core flow to the outside at the coannular nozzle, thereby achieving the coannular noise benefit.

Flow inversion must be performed with minimum loss to maintain optimum cycle performance and must be capable of sustained operation at high gas temperature levels while meeting commercial durability requirements. A program to develop and verify inverter technology would be comprised of several elements. First, conceptual design and configuration studies would be performed. This work includes defining the inverter geometry and flowpath, wall cooling requirements, cooling approaches, and materials. Flow visualization models would provide data pertaining to pressure loss, boundary layer formation, exit profile and integration with the exhaust nozzle. A subscale model flow rig would be used to evaluate and refine the system. Testing would concentrate on assessing aerodynamic performance for verification of analytical and flow visualization results.

The inverter configuration would be designed based on the preceding work and tested in a demonstrator engine. Engine testing would

address interactive component behavior such as profile effects on nozzle performance as well as performance and durability aspects.

4.2.8 Test Facilities

In formulating the technology plans and programs, test facilities and their limitations were reviewed to determine the impact on the different technology programs. This review included facilities for high-pressure spool and demonstrator engine tests as well as facilities for cascade and component rig tests.

In general, the test facilities do not limit the range of operating conditions for testing a subscale demonstrator engine in the 113 to 136 kg/sec (250 to 300 lb/sec) flow class and only partially limit the test conditions for a flight size engine in the 272 to 408 kg/sec (600 to 900 lb/sec) flow class. The core or high-pressure spool can be tested at elevated temperatures and pressures in the Pratt & Whitney Aircraft Andrew Willgoos Turbine Laboratory to simulate key engine operating conditions. Inlet heating and ducting capabilities are such that the pressure supplied to the core is sufficient to simulate sea level takeoff and more than adequate for other flight conditions.

Sea level performance testing of a subscale demonstrator can be conducted in various indoor test stands at the Commercial Products Division in Connecticut or outdoor test stands at the Government Products Division in Florida. Static noise evaluations can be performed at subcontractor facilities.

Engine altitude performance and durability tests would be conducted at the Pratt & Whitney Aircraft Andrew Willgoos Turbine Laboratory in Connecticut. In this facility, a subscale demonstrator engine could be tested at simulated altitudes of up to 10670 m (35,000 ft). Durability testing could be accomplished at higher simulated altitudes if nozzle performance measurement is not a requirement. Altitude testing of a flight size demonstrator engine would be limited to 9100 m (30,000 ft) and a flow capability of 3.8 kg/sec (700 lb/sec.)

With exception of the fan, main combustor and duct burner components, the test facilities do not impose any serious limitations to cascade or major component rig test programs. For the fan, it would be necessary to evaluate the fan rig in subscale engine size because of limited engine drive power requirements. This practice, however, has been successfully employed at Pratt & Whitney Aircraft in developing large fan systems, and thereby does not represent a constraint.

The full annular rig used in the Main Combustor Technology Programs is not capable of simulating the design or near design pressure conditions. Therefore combustor development is limited to either sector or segment rigs because of flow/pressure limitations. Pressure levels that can be attained in an annular rig, however, are more than satisfactory for developing the liner dilution hole pattern and performing a checkout of the burner component. Similarly, segment or sector rigs are used to develop the duct burner configuration. The technology programs for the main combustor and duct burner have been structured to permit adequate component testing.

4.3 DEMONSTRATOR CONFIGURATION DEFINITION

4.3.1 Introduction

4.3.1 Introduction

In developing the different areas of technology, engine demonstration is a prerequisite to technology readiness. Although component rig testing is an expedient and an invaluable development tool, only engine testing enables duplicating the total operating environment in terms of pressures, temperatures and interactive aeromechanical forces to wholly assess the technology concept.

A technology demonstrator vehicle can consist of either a core demonstrator, a low spool demonstrator, or a full engine demonstrator. A core is a cost effective way to demonstrate high spool technologies, especially the key high temperature technologies (high-pressure turbine and main burner). A low spool demonstrator engine enables demonstration of critical low-pressure spool components, along with the coannular nozzle, duct burner and controls technologies. A low spool demonstrator would utilize an existing core spool to reduce cost and risk, and yet provides an overall engine test to demonstrate the critical components and cycle concept. Finally, an all new demonstrator engine design combines the elements of the core and low spool for a full demonstration of the cycle and components as a step towards substantiation of technology readiness.

Effort in this part of the program focused on defining engine configurations that could be used as a demonstrator vehicle for a planned technology program. This involved first conducting engine screening analyses to determine candidate engine configurations, followed by additional refinement analyses to identify the most attractive approaches. The configurations identified for a demonstrator engine on the basis of this study represent a tradeoff between cost and level of demonstrated technology.

4.3.2 Configuration Screening

Two basic approaches were considered for a full engine demonstrator. The first consisted of a new advanced-technology demonstrator engine that incorporates all new components specifically developed and optimized for a VCE. The second approach involved application of either existing or near term high-pressure spools in the engine configuration.

When selecting an existing core, it is desirable that the core be an advanced technology design which does not significantly impact the design goals of the low-pressure spool

components such as the fan and low-pressure turbine. In addition, a core with a relatively large airflow size is very beneficial since this will provide a larger size demonstrator engine and thus a larger scale duct burner component closer to the flight engine size.

A total of eight core spools, including a new engine, was considered for a demonstrator. The different configurations are listed in Table 4.3-1. On the basis of technology level, flow capacity and low-pressure spool integration considerations, the following configurations were selected for further evaluation: (1) a new advanced technology demonstrator, (2) an ATEGG core based demonstrator, (3) a F100 core based demonstrator and (4) an EEE core based demonstrator. Each of these configurations is described in following sections.

**TABLE 4.3-1
DEMONSTRATOR ENGINE
CONFIGURATIONS SCREENED**

New Advanced Technology Engine

ATEGG (Advanced Turbine Engine Gas Generator) Core

F100 Core

EEE (Energy Efficient Engine) Core

JT9D Core

JT10D Core

JT3D Core

JT8D Core

Of the other considerations, the JT9D core is a relatively high flow, large configuration that could provide a larger size demonstrator. However, the 9:1 core pressure ratio is too high. Elimination of the rear compressor stages to rematch to the 6:1 VSCE compressor pressure ratio has too serve an effect on the combustor and turbine components to be an acceptable modification. Elimination of front stages would be more practical, but would reduce the flow capacity and effectively negate much of the flow size advantage. Finally, the resulting engine cycle with this compressor rematch

or removed stages would be a low speed, large diameter core that would impact the duct burner elevation and also result in a low-pressure spool elevation mismatch.

The JT10D core is in the same size range as the EEE core and is designed with a higher core pressure ratio. Also, the two high-pressure turbine stages in the JT10D configuration preclude efficient incorporation of a single-stage, advanced, supersonic high-pressure turbine.

The two remaining core systems considered, the JT3D and JT8D, offer no size advantage. Moreover, these are current technology configurations that operate at relatively low speeds, and thereby appreciably limit the range of technology demonstration.

4.3.3 Description of Candidate Configurations

4.3.3.1 New Advanced-Technology Demonstrator Engine

A new engine incorporating all advanced technology components would result in a demonstrator vehicle that most closely approaches the VSCE-502B flight concept. The engine, as initially configured, would contain all the advanced technologies available and components outlined in Section 4.2. In addition, with parallel development, even farther term technologies such as a ceramic material turbine vane could subsequently be incorporated in the engine for a full demonstration of the VSCE-502B technology goals.

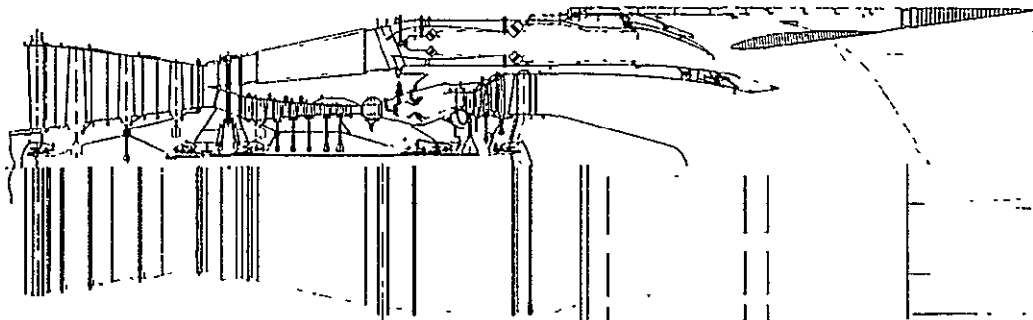

	Compressors			Turbines	
	Fan	HPC		HPT	LPT
Pr	3.3	6.15	Pr	3	3.6
No. of Stages	3	6	No. of Stages	1	2
$U_{tip}/\sqrt{\theta} \sim \text{m/sec}$ (ft/sec)	497(1630)	366(1200)	$\Delta h \sim \text{Joules/kg}$ (Btu/lb)	4.35×10^5 (187)	3.98×10^5 (171)
$W/A \sim \text{kg/sec/m}^2$ (lb/sec/ft ²)	205(42)	181(37)	V_{mean} ($\propto u/\sqrt{\Delta h}$)	0.54	0.5
Variable Geom.	IGV+EGV	EGV+3	$U_{rim\ max} \sim$ m/sec (ft/sec)	452(1485)	250(823)

Figure 4.3-1 Preliminary Definition of VSCE-502B Demonstrator Engine - This approach provides a vehicle to demonstrate all critical technologies and components identified for the VSCE-502B base engine.

The mechanical configuration for the all new demonstrator engine is the same as the VSCE-502B, which is described in Section 4.1.2. A preliminary definition of the engine configuration is shown in Figure 4.3-1, along with a listing of key cycle characteristics. As shown, the engine is a dual spool configuration, using duct burning augmentation in conjunction with a coannular exhaust nozzle. The fan is a multi-stage system designed to operate at moderately high tip speeds and incorporates variable geometry inlet and exit guide vanes. The six-stage compressor also uses variable geometry stators as well as advanced materials and operates at high mechanical loadings. The high-pressure turbine is a cooled, single-stage design and the low-pressure turbine is a two-stage design. Both the main combustor and duct burner are based on Vorbix technology for operation at high temperatures with low emissions and high performance.

The new demonstrator could be procured as a subscale engine in the 113-136 kg/sec (250-300 lb/sec) flow size in order to reduce program cost and time as well as facilitate engine handling and still provide adequate demonstration. If required, the engine could also be procured in the size projected for a flight size engine, which is in the 272-408 kg/sec (600-900 lb/sec) flow range. This final flow size is contingent on the airplane requirements and would be defined as part of the ongoing and planned integration studies.

4.3.3.2 F100 Core Demonstrator Engine

The F100 core provides the most advanced technology in service today. The use of this proven core system can be exploited to reduce program cost and risk.

A cross sectional view of the F100-PW-100 engine design is presented in Figure 4.3-2. This engine is a dual spool turbofan with mixed-flow augmentation. The core has a ten-stage high-pressure compressor driven by a two-stage, air-cooled, high-pressure turbine. The inlet vanes to the high-pressure compressor have variable geometry capability along

with the first two stator rows. The annular combustor in this core has a relatively high exit temperature capability of 1400°C (2560°F), making it suitable for a low spool demonstrator engine.

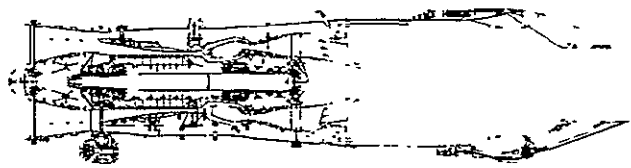

Figure 4.3-2 F100-PW-100 Engine Cross Section - This engine is the powerplant for the advanced F-16 weapon system, and incorporates numerous technology advances.

The design pressure ratio of the high-pressure compressor is 8:1. For this application, this ratio is too high, and when integrated with a scaled VSCE-502B fan it produces an unacceptably high overall pressure ratio. Again, elimination of rear compressor stages presents too much of a change to the combustor and turbine, and elimination of the front stages reduces the core size. Consequently, the F100 high-pressure compressor was rematched along a nominal operating line to a pressure ratio of 7.1:1, as shown in Figure 4.3-3. Matching along the nominal operating line obviates the necessity for a turbine vane class (nozzle area) change or blade restagger (redesign). Therefore, the F100 core could be used without

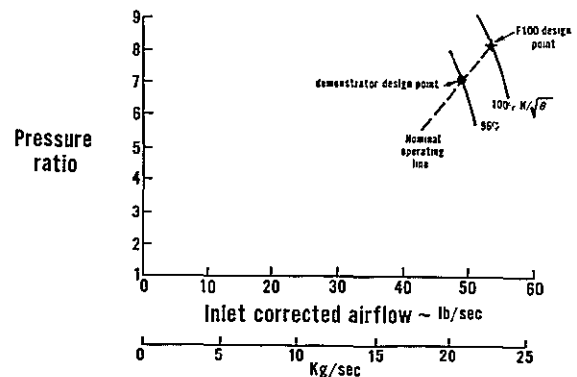
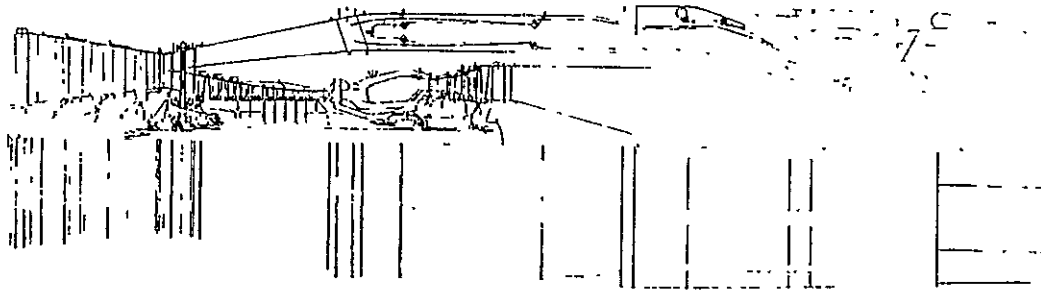

Figure 4.3-3 F100 High-Pressure Compressor Match-Compressor matching permits using the F100 core without necessity of significant modification.

significant modification. It should be noted that the VSCE-502B, with its inverse throttle schedule and core high-flowing features, matches the high spool with a 14 percent higher rotational speed at supersonic cruise relative to takeoff, which is the aerodynamic design point for the compressor. Therefore, rematching the F100 compressor to the lower pressure ratio, as shown in Figure 4.3-3, en-

ables the F100 demonstrator engine to simulate this unique VSCE matching feature.

A preliminary engine definition was made using the F100 core with a scaled VSCE-502B low-pressure spool. Figure 4.3-4 presents a cross sectional view of the engine configuration and the cycle characteristics.



	Compressors			Turbines	
	Fan	HPC		HPT	LPT
Pr	3.3	7.1	Pr	3.7	3.6
No. Stages	3	10	No. Stages	2	2
$U_{tip}/\sqrt{\theta} \sim \text{m/sec}$ (ft/sec)	497(1630)	323(1060)	$\Delta h \sim \text{Joules/kg}$ (Btu/lb)	4.58×10^5 (197)	3.54×10^5 (152)
$W/A \sim \text{kg/sec/N}^2$ (lb/sec/ft ²)	205(42)	161(33)	V_{mean} ($\alpha u/\sqrt{\Delta h}$)	0.58	0.54
Variable Geom.	IGV + EGV	IGV + 2			

Figure 4.3-4 Demonstrator Engine Concept – This configuration utilizes the F100 core with a scaled VSCE-502B low-pressure spool.

Scaled elevations of the low-pressure spool components closely match the F100 core. Of particular interest, the two-stage low-pressure turbine nearly matches that of the scaled VSCE-502B. However, because of the different design requirements for the low-pressure spool, especially rotational speed and work level, the low-pressure turbine airfoils and case would be a new design for this demonstrator. The VSCE fan design, especially the

size, would require all new hardware. Also, the duct burner and exhaust nozzle components closely approximate the base engine, as scaled to a flow size of 132 kg/sec (290 lb/sec). The close agreement of these components is clearly depicted in Figure 4.3-5.

Overall, this demonstrator engine concept offers an attractive approach. However, one apparent limitation is the amount of high temperature technology that can be demonstrated.

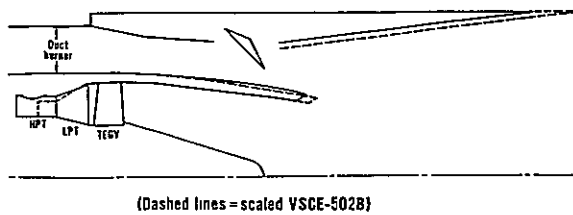

Figure 4.3-5 Scaled Elevation of Low-Pressure Spool Components with F100 Core - The elevation of the turbine is in close agreement with the VSCE-502B base engine, which is indicated by the dashed lines.

As discussed earlier, the technology requirements for the VSCE-502B high-pressure turbine are oriented towards a single-stage transonic turbine capable of operating at high speeds and sustaining high aerothermal-mechanical stress loadings. The two-stage high-pressure turbine in the F100 core does not approach these requirements and, consequently, these technologies cannot be demonstrated within the context of this engine configuration.

4.3.3.3 ATEGG Core Demonstrator Engine

The ATEGG core is an advanced technology system that is being developed under the ongoing Air Force-sponsored Advanced Turbine Engine Gas Generator Program. The technology goals outlined in this program are in many respects similar to the VSCE and IFE core technology goals. In particular, the ATEGG Program emphasizes achievement of high temperature levels, high aeromechanical loadings and high component efficiencies using component concepts and materials that reflect a substantial departure from the state-of-the-art.

The ATEGG core selected for a demonstrator engine is designated PWA 685-221. This core spool is comprised of an advanced high-through flow compressor, a high Mach number swirl-flow combustor, and a variable geometry single-stage turbine. Different components of the PWA 685 gas generator are presently being

designed, and testing of the PWA 685-221 core is anticipated during the 1981-82 time period. Because of the nature of the ATEGG Program, details pertaining to the component designs are classified as "Confidential" information and are proprietary to United Technologies Corporation. Therefore, discussion of the ATEGG core will be restricted to applicability to the demonstrator program.

As with the F100 high-pressure compressor, it was necessary to rematch the ATEGG compressor. The compressor rematch, as shown in Figure 4.3-6, allows the ATEGG core to be used without modification and prevents overspeeding the high-pressure rotor.

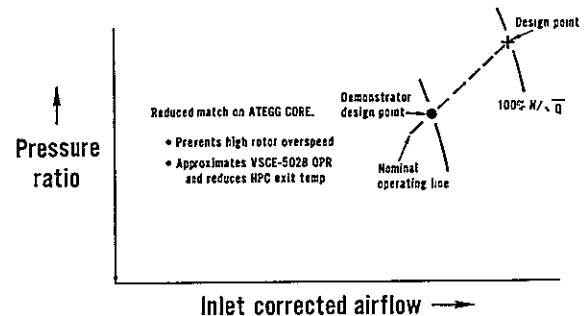
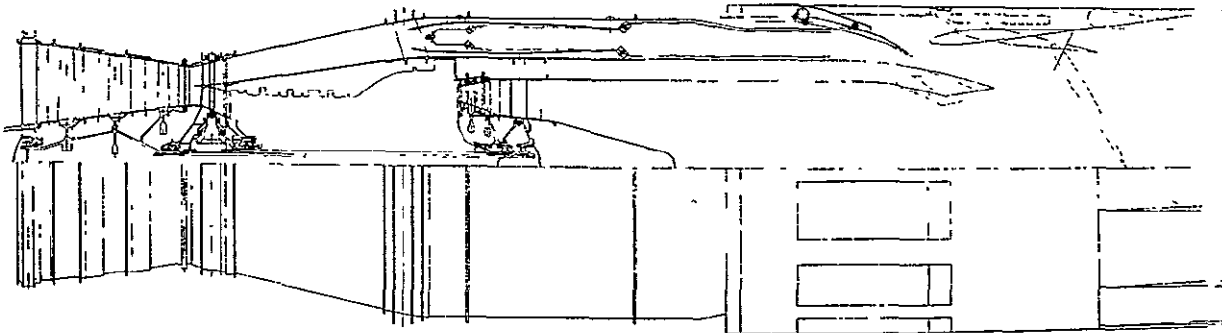

Figure 4.3-6 ATEGG High-Pressure Compressor Match - The reduced match on the ATEGG core precludes high-pressure rotor overspeed, approximates the base engine overall pressure ratio and reduces the compressor exit temperature.

Two approaches were considered for developing a demonstrator engine around the ATEGG core. The first involved integrating a scaled VSCE-502B low-pressure spool with the core as studied previously with the F100 core. The second approach consisted of using a scaled existing advanced fan design, while retaining the general VSCE-502B low-pressure turbine configuration.

Figure 4.3-7 shows a conceptual definition of an engine based on the ATEGG core and scaled VSCE-502B low-pressure spool. Also presented are key low-pressure spool parameters. The elevations of the fan and low pressure turbine components closely match the ATEGG core.

As illustrated in Figure 4.3-8, the two-stage low-pressure turbine approximates that of the base engine. In addition, the duct burner and exhaust nozzle components closely simulate the base engine concept at the resulting flow size of 122 kg/sec (268 lb/sec).



	<u>Fan</u>		<u>LPT</u>
Pr	3.3	Pr	3.5
No. Stages	3	No. Stages	2
$U_{tip} \sqrt{\theta}$ m/sec (ft/sec)	497(1630)	$\Delta h \sim$ Joules/kg (Btu/lb)	3.8×10^5 (164)

Figure 4.3-7 Demonstrator Engine Cross Section – This engine configuration, as conceptually defined, integrates a new scaled VSCE-502B low-pressure spool with the ATEGG core designated PWA 685-221.



(Dashed lines = scaled VSCE 502B)

Figure 4.3-8 Demonstrator With ATEGG Core - The elevation of the ATEGG high-pressure turbine provides a close match with the base engine concept.

The second engine configuration studied replaces the base engine fan with an advanced fan system designed and demonstrated under the Air Force-sponsored Advanced Propulsion Subsystem Integration (APSI) Program. This fan is a multistage design capable of high tip speed operation as well as high system efficiency. It can be scaled and rematched to provide the same cycle and aerodynamic characteristics as the VSCE fan. One of the unique features of this fan design is the use of a composite material in the first-stage blades. Other features include variable geometry stators and advanced blade tip sealing concepts.

Figure 4.3-9 shows the preliminary engine configuration using the APSI fan, ATEGG core, and VSCE-502B low-pressure turbine. In this configuration, the APSI fan must be scaled in size to meet the demonstrator cycle requirement. Although this necessitates a mechanical redesign of the fan, substantial cost savings would be attained relative to the design of a new component since many of the design features are readily scalable and the fan aero-

dynamics represent a proven design. These factors contribute to lower design costs and program costs could be further trimmed by eliminating fan rig test programs. However, since the APSI fan operates at a higher tip speed than the fan in the base engine design, the low-pressure turbine would operate at higher rotational speeds. This increases the turbine blade stresses and decreases the stage loading relative to the VSCE-502B.

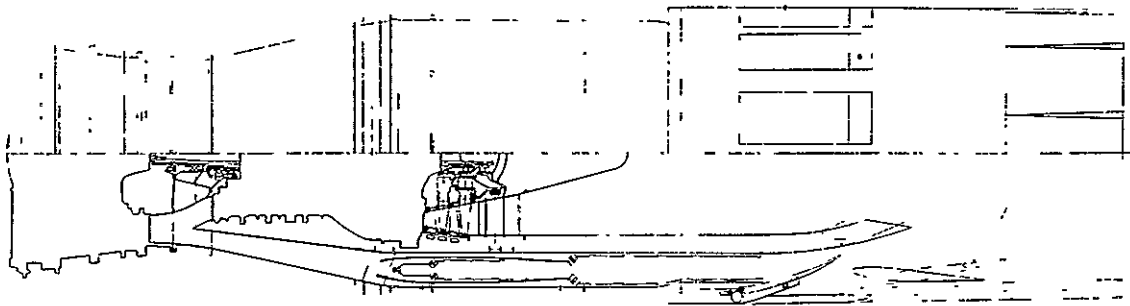

Figure 4.3-9 Demonstrator Engine Cross Section-This engine definition replaces the three-stage base engine fan with an advanced high speed (scaled APSI) fan.

With either low-pressure spool configuration, a demonstrator with an ATEGG core is a suitable vehicle for demonstrating all critical technologies, except for high-pressure compressor performance and main combustor emissions reduction. The ATEGG core, because of its high rotational speed and turbine temperature capability, can be used to demonstrate critical VSCE high-pressure turbine technologies. Specific advanced technologies related to durability (heat transfer/materials) could be demonstrated by substituting a new single stage turbine design for the ATEGG turbine. Key aerodynamic advances could also be evaluated via this substitution.

Also, selected liners in the ATEGG swirl combustor have similar heat transfer characteristics to the VSCE and IFE main combustor liners. Improvements in these ATEGG combustor liner could thus be used to demonstrate liner durability for the combustor component.

4.3.3.4 EEE Core Demonstrator Engine

The goal of the current NASA-sponsored Energy Efficient Engine (EEE) Program is to demonstrate advanced technologies for an energy efficient engine for a commercial subsonic transport that is envisioned operational in the early 1990 time period. The core spool in the EEE will employ the latest advancements in commercial engine technology. A short, stiff high-pressure rotor system and a single-stage, cooled high-pressure turbine are major design features contributing to high performance and low operating costs. The compressor operates at high rotational speeds and contains the latest concepts in "low loss" technology. The combustor is a staged design to achieve low emissions and high overall performance. A single-stage, transonic high-pressure turbine uses single crystal airfoils as well as other "low loss" aerodynamic technology concepts, for improved performance. Both the compressor and turbine units incorporate active clearance control for improved system efficiency.

As scheduled, the EEE core demonstrator will undergo experimental testing in 1982.

The EEE core design pressure ratio of 14:1, as with the F100 and ATEGG cores, is unacceptably high for the demonstrator cycle. As an additional complication, the Energy Efficient Engine fan pressure ratio is much lower than the VSCE, thereby introducing a significant difference between the physical and corrected rotating speeds of the compressors for these two engines. To reduce the pressure and also to compensate for this difference in rotating speed, the first two stages of the compressor would be removed and the resulting eight-stage compressor rematched along the operating line to a pressure ratio of 6:1. This is shown on the compressor map in Figure 4.3-10. Removal of the front stages and compressor rematching produced only minimal changes to the core. The combustor was unaffected and turbine inlet flow area remained unchanged. However, since the rematched cycle has a turbine expansion ratio of 3:1, compared to the EEE design level of 4:1, restagging the blade camber angle may be necessary in order to match the turbine while maintaining turbine efficiency. A substitution of higher temperature compressor materials may also be required, depending on the supersonic Mach number that this experimental program entails.

Removal of the front two compressor stages reduced the core airflow. As a consequence, integrating this core with a scaled VSCE-502B fan resulted in the smallest demonstrator engine configuration of the different candidate configurations studied with a flow size of 109 kg/sec (248 lb/sec). Although this flow is 15 percent lower than the engine with the F100 core, it is only 7.5 percent lower than that based on the ATEGG core, and would still be a suitable size for a VSCE experimental engine.

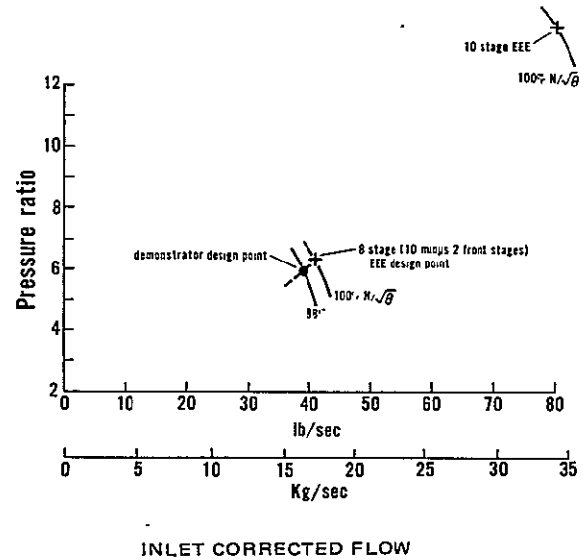
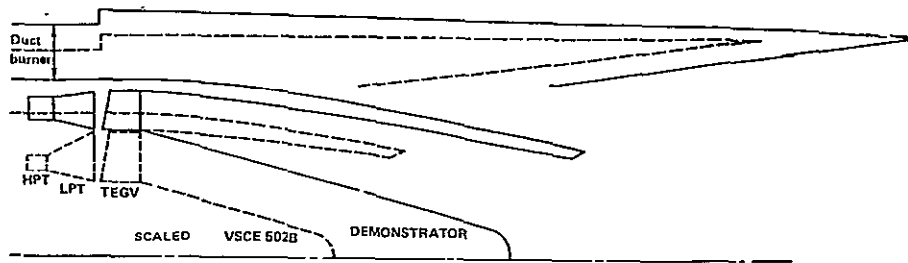

Figure 4.3-10 EEE High-Pressure Compressor Match - Matching the EEE compressor to the demonstrator design point is achieved by analytically removing the first two stages of the compressor.

The resulting component design parameters and cycle characteristics of this configuration are presented in Figure 4.3-11, along with the elevation match between the core and the base engine scaled low-pressure turbine. As indicated, there is an appreciable mismatch in elevation. Removal of the compressor stages transformed the EEE core into a relatively low work system with a high turbine elevation. The net result is that the low-pressure turbine is at too great an elevation for two stages, but not practicable as a single stage unit.

Furthermore, the difference in elevation moves the duct burner to a larger diameter (H/L becomes smaller) so that it becomes more unlike the ultimate VSCE-502B duct burner concept. The significant changes in the duct burner and nozzle flowpath from the base engine configuration are evident in Figure 4.3-11.



	Compressors			Turbines	
	Fan	HPC		HPT	LPT
Pr	3.3	6.0	Pr	3.0	3.77
No. Stages	3	8	No. Stages	1	2
$U_{tip}/\sqrt{\theta} \sim$ M/sec (ft/sec)	497(1630)	323(1060)	Δh Joules/kg (Btu/lb)	3.95×10^5 (170)	3.86×10^5 (166)
$W/A \sim$ kg/sec/N ² (lb/sec/ft ²)	205(42)	151(31)	V_{mean} ($\propto u/\sqrt{\Delta h}$)	0.66	0.75

Variable Geom. IGV + EGV IGV + 2

Figure 4.3-11 Preliminary Definition with EEE Core – Removing the two compressor stages imparts a significant mismatch between the elevation of the core and a scaled VSCE-502B low-pressure turbine which affects the duct burner and nozzle flowpaths.

In summary, although the EEE core provides much of the technology base for the core technologies, the hardware has little commonality with the requirements of a demonstrator. The core, by itself, offers an acceptable demonstration vehicle to evaluate high temperature technologies, but when combined with a scaled VSCE-502B low-pressure spool, the low-pressure turbine, duct burner and exhaust nozzles do not adequately reflect realistic VSCE components.

4.3.4 Predicted Performance

Analyses were conducted with the different demonstrator engine configurations defined to determine cycle and fuel consumption characteristics as well as noise and emissions levels. The method of study and results of

these analyses are discussed in the following sections.

4.3.4.1 Engine Performance and Fuel Consumption Trends

The engine demonstrators using existing cores were analytically configured to simulate the base VSCE-502B cycle. Specifically, fan pressure ratio and cycle bypass ratio at the design sea level static condition were retained. At this same condition, design parameters for the compression system were established, whereas the turbine component design parameters were established at the critical supersonic cruise flight condition. The turbine operating temperature was limited by the maximum temperature of each respective core spool.

However, since the ATEGG core offers more than adequate temperature capability to comply with the base engine requirements, the low-pressure turbine inlet temperature was limited to the base engine value.

A comparison of the resulting thermodynamic cycles with the base VSCE-502B is presented in Table 4.3-II. For a further comparison, cycle parameters of the VCE F100/testbed demonstrator configuration are also listed. Although not indicated, calculated duct burner airflows are 49, 38 and 24 percent higher than the VCE/testbed for cycles containing the F100 testbed for cycles containing the F100, ATEGG and EEE cores, respectively.

Table 4.3-II also presents the estimated thrust specific fuel consumption (TSFC) characteristics of the different cycles in relation to the base engine for both the subsonic and supersonic cruise conditions. As would be expected on the basis of this comparison, none of the cycles is capable of equaling the base engine values, particularly in the supersonic cruise mode.

Engine performance predictions were made for the selected demonstrator engine for several key flight conditions encompassing both subsonic and supersonic flight modes. The study conditions included a sea level static design point, supersonic cruise, sea level takeoff, subsonic cruise, subsonic climb, and transonic climb and acceleration. This range of conditions reflects the most stringent duct burning flight condition, takeoff, as well as the most stringent operating condition for the turbomachinery, supersonic cruise.

Key cycle and performance parameters for the sea level static design point are listed in Table 4.3-III. This condition establishes the cycle and the design parameters for the compression system. Predicted performance of the VSCE-502B was based on a 408 kg/sec (900 lb/sec) flow size for consistency with the work conducted previously under the Supersonic Cruise Aircraft Research (SCAR) studies. The engines were analytically configured to provide a nozzle jet velocity ratio (duct stream jet velocity divided by the core stream jet velocity) of 1:1 at this nonaugmented design condition. Using the base

TABLE 4.3-II
DEMONSTRATOR CYCLES COMPARED WITH
BASE VSCE-502B AND VCE F100/TESTBED CYCLES

	VSCE-502B	VCEE Demonstrator Cores			VCE Testbed
		F100	ATEGG	EEE	
Engine Airflow Size (SLS) kg/sec (lb/sec)	(600-900) 262-408	132 (290)	122 (268)	109 (241)	105 (232)
Bypass Ratio (SLS)	1.3	1.22	1.3	1.32	0.9
Fan Pressure Ratio (SLS)	3.3	3.3	3.3	3.3	3.1
Overall Pressure Ratio (SLS)	20	23	18.3	19.5	21
Maximum Combustor Exit Temperature °C (°F)	1480 (2700)	1400 (2560)	—	1400 (2550)	1400 (2560)
Relative TSFC					
At Supersonic Cruise (%)	Base	+13.3	+5.7	+4.8	—
At Subsonic Cruise (%)	Base	+4.6	+7.7	+0.4	—

engine fan pressure ratio and a velocity ratio of 1:1, combustor exit temperature levels were established for each engine. As indicated in Table 4.3-III, the design combustor exit temperature ranged from 17 to 131°C (30 to 235°F) higher than the design value for the base engine.

The reference off-design airflow schedule used for the VSCE-502B is based on the utilization of a variable geometry supersonic inlet designed for a Mach number of 2.4. This airflow schedule dictates the throttle ratio (or maximum versus design combustor exit temperature schedule) and the amount of primary jet area variation. Since the demonstrator cycles with existing core spools have a higher sea level static combustor exit temperature and are limited to a maximum temperature at or below that of the base engine, except for the ATEGG core, the respective throttle ratios do not enable these cycles to duplicate the baseline airflow schedule. This is exemplified in Figure 4.3-12. In order to meet the flows shown in this figure, the primary stream jet areas were increased by 10

percent over the design point, as limited by the low-pressure turbine expansion ratio, versus the 6 percent area increase used for the base VSCE-502B engine.

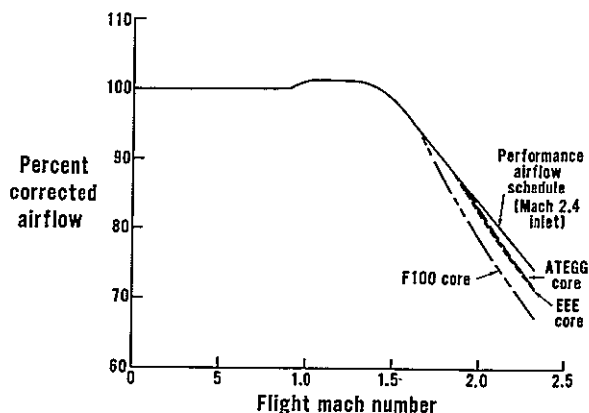

Figure 4.3-12 Off-Design Inlet Airflow Schedule - The demonstrator cycles do not conform to the reference airflow schedule, but this, in itself, is not a serious limitation for technology demonstration.

TABLE 4.3-III

CYCLE AND PREDICTED PERFORMANCE CHARACTERISTICS FOR A SEA LEVEL STATIC DESIGN POINT

	<u>VSCE-502B</u>	<u>Demonstrator w/F100 Core</u>	<u>Demonstrator w/ATEGG Core</u>	<u>Demonstrator w/EEE Core</u>
Corrected Inlet Airflow ~ kg/sec (lb/sec)	408 (900)	131 (289.5)	122 (268)	109 (241)
Bypass Ratio	1.3	1.22	1.3	1.32
Fan Pressure Ratio	3.3	3.3	3.3	3.3
Overall Pressure Ratio	20.0	23.0	18.3	19.5
HPC Corrected Airflow ~ kg/sec (lb/sec)	67 (147)	22 (49)		18 (39)
HPC Pressure Ratio	6.2	7.1		6.0
HPC Discharge Temperature ~ °C (°F)	471 (880)	527 (980)	452 (845)	457 (854)
Combustor Exit Temperature ~ °C (°F)	1199 (2190)	1282 (2340)		1216 (2220)
Duct Burner Temperature ~ °C (°F)	-	-	-	-
Thrust (Installed) ~ N (lb)	180,110 (40490)	57,115 (12840)	53,335 (11990)	47,885 (10765)
TSFC (Installed) ~ kg/hr/N (lb/hr/lb)	0.0628 (0.616)	0.059 (0.646)	0.0693 (0.680)	0.0628 (0.616)

A meaningful demonstration of engine/inlet airflow matching can be achieved with any of the demonstrator cycles. The effect of throttle ratio on airflow schedule can be easily substantiated, and demonstrating a variable primary jet area to adjust airflow over the flight regime is still inherent in these cycles.

The key cycle and performance parameters for the supersonic flight condition are listed in Table 4.3-IV. The data are presented for a typical cruise thrust level as scaled by airflow relative to the design airflow of the VSCE-502B concept. Because the cycles are scaled by airflow at the design condition and have a lower relative airflow at the supersonic condition versus the base engine, the demonstrator cycles operate at a higher duct burner temperature to meet the scaled thrust setting and exhibit a higher fuel consumption, as indicated in Table 4.3-IV. The corresponding installed fuel consumption trends for supersonic cruise are shown in Figure 4.3-13.

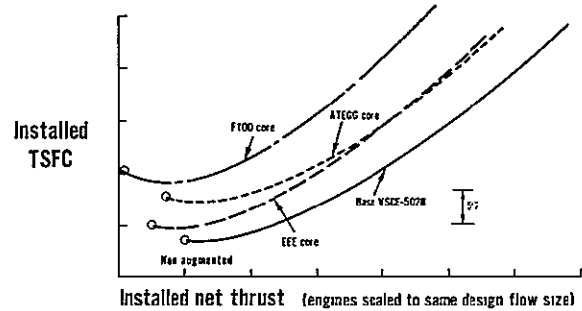

Figure 4.3-13 Fuel Consumption Trends for Supersonic Cruise – Relative to the VSCE-502B, the scaled experimental engines all have higher TSFC levels, primarily due to the cycle differences summarized in Table 4.3-IV.

Cycle and performance parameters at the sea level takeoff condition are presented in Table 4.3-V. The data in this table reflect the maximum power condition with a lower fan pressure ratio to reduce jet and shock noise. A

TABLE 4.3-IV

CYCLE AND PREDICTED PERFORMANCE CHARACTERISTICS FOR SUPERSONIC CRUISE CONDITIONS
(Altitude 16154 m (53,000 ft), 2.32 Mn, +8°C Hot Day (+14°F))

	VSCE-502B	Demonstrator w/F100 Core	Demonstrator w/ATEGG Core	Demonstrator w/EEE Core
Corrected Inlet Airflow ~ kg/sec (lb/sec)	304 (670)	88 (195)	88 (193)	78 (173)
Bypass Ratio	1.51	1.55	1.57	1.58
Fan Pressure Ratio	2.45	2.23	2.37	2.35
Overall Pressure Ratio	11.9	11.0	9.9	10.5
HPC Corrected Airflow ~ kg/sec (lb/sec)	58 (127)	18 (39)		15 (33)
HPC Pressure Ratio	4.9	5.0		4.5
HPC Discharge Temperature ~ °C (°F)	710 (1310)	718 (1325)	660 (1220)	666 (1230)
Combustor Exit Temperature ~ °C (°F)	1480 (2700)	1400 (2560)		1400 (2550)
Duct-Burner Temperature ~ °C (°F)	733 (1352)	988 (1810)	802 (1475)	849 (1560)
Thrust (Installed) ~ N (lb)	113,500 (25,515)	36,520 (8210)	33,810 (7600)	30,390 (6833)
TSFC (Installed) ~ kg/hr/N (lb/hr/lb)	0.137 (1.343)	0.155 (1.522)	0.145 (1.419)	0.144 (1.408)

nozzle jet velocity ratio of 1.7:1 is maintained to ensure the coannular noise benefit.

Performance information pertaining to both subsonic climb, the maximum nonaugmented flight condition, and subsonic cruise, a typical power condition (scaled by design airflow size), is tabulated in Tables 4.3-VI and VII, respectively. Fuel consumption trends are shown in Figure 4.3-14 for the subsonic cruise condition.

The final flight condition evaluated in this study was transonic climb and acceleration. Table 4.3-VIII contains the key cycle and performance data for this condition.

4.3.4.2 Exhaust Emissions Prediction

Exhaust emissions of the demonstrator cycles using existing core spools were determined analytically and then compared to the levels predicted for the VSCE-502B engine. This analysis included the pollutants of oxides of

nitrogen (NO_x), carbon monoxide (CO) and total unburned hydrocarbons (THC). The production of CO and THC is related to the incomplete combustion of hydrocarbon fuel, while NO_x is a product of local combustion temperatures and residence time.

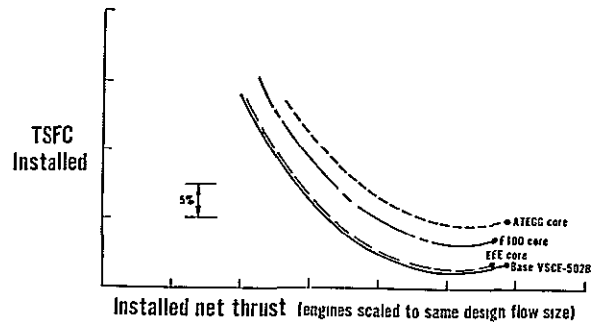

Figure 4.3-14 Fuel Consumption Trends for Subsonic Cruise - At subsonic cruise, fuel consumption trends are more closely in line with the base engine, particularly the EEE core, which is specifically configured for energy efficiency during subsonic operation.

TABLE 4.3-V
CYCLE AND PREDICTED PERFORMANCE CHARACTERISTICS FOR SEA LEVEL TAKEOFF CONDITIONS
(0.3 Mn, + 10°C Hot Day (+18°F))

	VSCE-502B	Demonstrator w/F100 Core	Demonstrator w/ATEGG Core	Demonstrator w/EEE Core
Corrected Inlet Airflow ~ kg/sec (lb/sec)	408 (900)	131 (289.5)	122 (268)	109 (241)
Bypass Ratio	1.53	1.42	1.51	1.51
Fan Pressure Ratio	2.8	2.8	2.8	2.8
Overall Pressure Ratio	18.7	21.2	16.9	18.2
HPC Corrected Airflow ~ kg/sec (lb/sec)	71 (156)	23 (51)		19 (41)
HPC Pressure Ratio	6.8	7.5		6.4
HPC Discharge Temperature ~ °C (°F)	516 (960)	557 (1035)	477 (890)	485 (905)
Combustor Exit Temperature ~ °C (°F)	1329 (2425)	1366 (2490)		1307 (2385)
Duct Burner Temperature ~ °C (°F)	1427 (2600)	1427 (2600)	1427 (2600)	1427 (2600)
Thrust Installed ~ N (lb)	271,050 (60,935)	77,020 (17,315)	74,130 (16,665)	68,725 (15,450)
TSFC (Installed) ~ kg/hr/N (lb/hr/lb)	0.178 (1.748)	0.198 (1.941)	0.197 (1.936)	0.187 (1.833)
Nozzle Jet Velocity Ratio ~ $V_{J_{duct}}/V_{J_{engine}}$	1.7	1.7	1.7	1.7

TABLE 4.3-VI

CYCLE AND PREDICTED PERFORMANCE CHARACTERISTICS FOR SUBSONIC CLIMB CONDITIONS
 (Altitude 11,000 m (36,089 ft) 0.9 Mn, + 8°C Hot Day (+14°F))

	<u>VSCE-502B</u>	<u>Demonstrator w/F100 Core</u>	<u>Demonstrator w/ATEGG Core</u>	<u>Demonstrator w/EEE Core</u>
Corrected Inlet Airflow ~ kg/sec (lb/sec)	408 (900)	131 (289.5)	122 (268)	109 (241)
Bypass Ratio	1.2	1.13	1.22	1.23
Fan Pressure Ratio	3.3	3.3	3.3	3.3
Overall Pressure Ratio	21.8	24.7	19.6	21.0
HPC Corrected Airflow ~ kg/sec (lbs/sec)	70 (154)	23 (51)		18 (40)
HPC Pressure Ratio	6.7	7.6		6.4
HPC Discharge Temperature ~ °C (°F)	427 (800)	477 (890)	402 (755)	407 (765)
Combustor Exit Temperature ~ °C (°F)	1177 (2150)	1246 (2275)		1179 (2155)
Duct Burner Temperature ~ °C (°F)	--	--	--	--
Thrust (Installed) ~ N (lb)	52,155 (11,725)	16,345 (3675)	15,545 (3495)	13,525 (3040)
TSFC (Installed) ~ kg/hr/N (lb/hr/lb)	0.0956 (0.938)	0.0994 (0.975)	0.1021 (1.001)	0.0955 (0.937)

TABLE 4.3-VII

CYCLE AND PREDICTED PERFORMANCE CHARACTERISTICS FOR SUBSONIC CRUISE CONDITIONS
 (Altitude 11,000 m (36,089 ft) 0.9 Mn, + 8°C Hot Day (+14°F))

	<u>VSCE-502B</u>	<u>Demonstrator w/F100 Core</u>	<u>Demonstrator w/ATEGG Core</u>	<u>Demonstrator w/EEE Core</u>
Corrected Inlet Airflow ~ kg/sec (lb/sec)	405 (893)	131 (289.5)	122 (268)	109 (241)
Bypass Ratio	1.28	1.2	1.3	1.31
Fan Pressure Ratio	3.39	3.4	3.4	3.39
Overall Pressure Ratio	19.7	22.9	17.9	19.4
HPC Corrected Airflow ~ kg/sec (lb/sec)	65 (143)	22 (48)		17 (38)
HPC Pressure Ratio	5.9	6.8		5.8
HPC Discharge Temperature ~ °C (°F)	402 (755)	454 (850)	382 (720)	391 (735)
Combustor Exit Temperature ~ °C (°F)	1046 (1915)	1132 (2070)		1068 (1955)
Duct Burner Temperature, ~ °C (°F)	--	--	--	--
Thrust (Installed) ~ N (lb)	42,390 (9530)	13,700 (3080)	12,745 (2865)	11,365 (2555)
TSFC (Installed) ~ kg/hr/N (lb/hr/lb)	0.0944 (0.926)	0.0988 (0.969)	0.1017 (0.997)	0.0948 (0.930)

TABLE 4.3-VIII

CYCLE AND PREDICTED PERFORMANCE CONDITIONS FOR TRANSONIC CLIMB AND ACCELERATION
(Altitude 11,125 m (36,500 ft), 1.3 Mn, + 8°C Hot Day (+14°F))

	VSCE-502B	Demonstrator w/F100 Core	Demonstrator w/ATEGG Core	Demonstrator w/BEE Core
Corrected Inlet Airflow ~ kg/sec (lb/sec)	413 (910)	132 (292)	123 (271)	110 (243)
Bypass Ratio	1.19	1.17	1.22	1.23
Fan Pressure Ratio	3.34	3.33	3.33	3.33
Overall Pressure Ratio	22.3	24.1	19.9	21.3
HPC Corrected Airflow ~ kg/sec (lb/sec)	70 (154)	23 (50)		19 (41)
HPC Pressure Ratio	6.8	7.3		6.5
HPC Discharge Temperature ~ °C (°F)	529 (985)	571 (1060)	502 (935)	507 (945)
Combustor Exit Temperature ~ °C (°F)	1391 (2535)	1404 (2560)		1393 (2540)
Duct Burner Temperature, ~ °C (°F)	1169 (2136)	1371 (2500)	1174 (2145)	1216 (2220)
Thrust (Installed) ~ N (lb)	154,155 (34,655)	50,040 (11,250)	46,130 (10,370)	41,415 (9,310)
TSFC (Installed) ~ kg/hr/N (lb/hr/lb)	0.147 (1.443)	0.163 (1.603)	0.152 (1.492)	0.152 (1.487)

Results of the analysis reflect the latest input available to the data base from two main sources. These include data and information from the NASA/P&WA Experimental Clean Combustor Program (ECCP) and the NASA-sponsored Duct Burner Screening Study completed under contract NAS3-19781. From the Experimental Clean Combustor Program data are available to project emissions levels in combustor systems based on Vorbix technology. Results from the Duct Burner Screening Study provided a more comprehensive definition of the duct burner and its emissions characteristics than achieved under earlier analytical studies.

With assimilation of the new information into the existing data base, revised emissions estimates were computed for the VSCE-502B for subsequent comparison with the combustors in the demonstrator engines. Figure 4.3-15 shows the projected emissions levels for both airport vicinity and altitude cruise as a function of chemical combustion efficiency of the duct burner. These emissions estimates are based on the same cycle conditions with the reduced fan pressure ratio used for the noise estimates. The shaded area depicts emissions from the main combustor, while the unshaded area depicts emissions from the duct burner.

Projections of different pollutants were based on direct scaling of data and do not reflect any allowances for deviation from nominal engine deterioration or margin for additional development of the combustors.

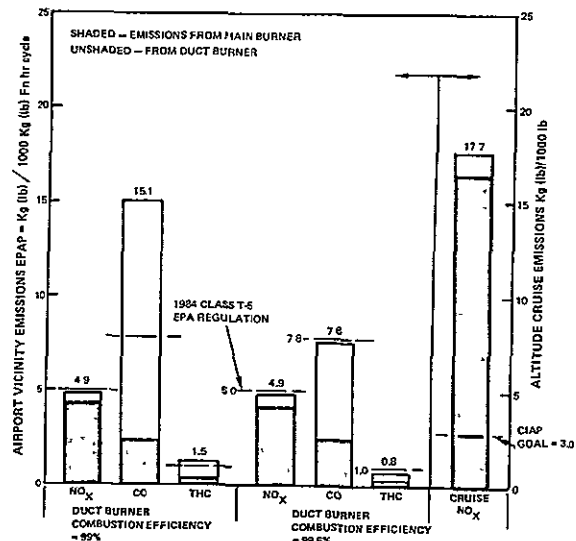

Figure 4.3-15 Updated VSCE-502B Exhaust Emissions Estimates - A chemical combustion efficiency of 99.6 is required to meet the 1984 Environmental Protection Agency CO rule for advanced supersonic engines.

The results indicate that by incorporating technology demonstrated during the ECCP in both the main combustor and duct burner, the VSCE-502B is capable of meeting the 1984 airport vicinity NO_x emissions requirements for class T5 engines. However, when the duct burner is designed for 99 percent combustion efficiency (the screening study goal under contract NAS3-19781), CO pollutants are nearly twice and THC 50 percent above the Environmental Protection Agency Parameter (EPAP) required levels. The excessive levels of CO and THC are attributable to duct burner operation at takeoff and climb-out. To reduce the output of these emissions to the required airport vicinity levels, a duct burner chemical efficiency of 99.6 percent is required. Cruise NO_x could be reduced by a decrease in cycle overall pressure ratio below the design value of 20. Studies indicate that this could be accomplished without any significant adverse effect on mission range.

The NO_x emissions at high altitude cruise, as indicated in Figure 4.3-15, are substantially higher than the proposed Climatic Impact Assessment Program (CIAP) goal of 3.0. Although the requirements for altitude NO_x are as yet not established, if they are constrained to this proposed level, more advanced emissions-reduction technology must be employed in gas-turbine engine main combustors to meet this goal.

Using a procedure similar to that for the base engine, emissions estimates were calculated for the combustors in the demonstrator cycles. The relative emissions levels, or EPAPs, are listed in Table 4.3-IX. These results reflect differences in the primary combustor design and technology level, rather than the duct burner. The contribution to emissions from the duct burner is essentially identical for all configurations since all cycles utilize the same duct burner design as well as duct conditions in the base engine.

TABLE 4.3-IX

**CYCLE EMISSIONS PROJECTIONS
RELATIVE TO VSCE-502B CONCEPT**

	EPAPs		
	NO _x	THC	CO
VSCE-502B	Base	Base	Base
F100 Core	+180%	+75%	+75%
ATEGG Core	+ 40%	+25%	+25%
EEE Core	Base	+19%	+19%

In the F100 engine, the main combustor is a conventional annular configuration and has not been optimized specifically for emissions reduction. This is reflected by the results in Table 4.3-IX.

The ATEGG swirl-flow combustor, although incorporating technology advancements for high temperature capability and high performance, is not designed for low emissions as a primary requirement. However, as indicated by the results, this system offers a promise for low emissions. These estimates are based on empirical data adjusted for the operating conditions of the demonstrator cycle.

In contrast to the other configurations, the EEE combustor is similar in many respects to the design in the base engine concept. This combustor design is based on Vorbix technology and incorporates the latest technology advances for low emissions. Predictions were derived from the ECCP data base, the same used in predicting VSCE-502B emissions characteristics. In addition, for this analysis the EEE combustor was assumed to be used without modification or optimized for a demonstrator cycle. Therefore, as a result of cycle differences, the emissions estimates would not be identical to the VSCE-502B, as shown in Table 4.3-IX.

4.3.4.3 Noise Prediction

A noise characterization analysis was conducted to determine the noise levels of the candidate demonstrator engines. As in the preceding emissions analysis, existing core engines were evaluated and estimates were compared to the base VSCE-502B concept.

The Pratt & Whitney Aircraft noise prediction system was used for this analysis. This system was recently updated and used in the VCE Testbed Program Planning and Definition Study (contract NAS3-20048) to calculate VSCE-502B noise levels, which serve as the basis for comparison in this evaluation. Basically, the update consisted of a refinement in the procedure used to estimate engine jet noise and the addition of new procedures for evaluating turbine and duct burner combustion noise levels.

In brief, the prediction system consists of several modules or subroutines that have the capability to predict noise generation by different sources. Prediction of jet noise for engines with coannular exhaust nozzles involves two separate noise components plus shock noise. These two include low frequency merged jet noise, which is generated downstream of the exhaust nozzle, and high frequency premerged jet noise, which is generated close to the nozzle exit by the high velocity fan stream. The low frequency component is calculated by the SAE ARP 876 method, utilizing downstream merged jet properties as input. For the high frequency noise component, correlations of experimental model data for coannular nozzles were made in order to predict the peak sound pressure level and shape. In addition, this procedure accounts for an ejector with either a hardwall or treated surface. As part of the system update, the proposed SAE shock noise prediction method was added to account for shock noise created by the high velocity bypass stream. This prediction system provides an empirical method for applying test data obtained from the NASA-sponsored model test program (contract NAS3-17866) to predict flight engine noise.

For fan noise, the predictions are based on a data base drawn from both engine and fan rigs. The data cover ranges of key factors, including fan tip speed, stage number and blade design.

On the basis of results obtained from a choked inlet noise study under NASA sponsorship (contract NAS3-16811), a 20 dB inlet noise suppression was applied to account for the effect of a choked inlet. The impact of not maintaining choked flow conditions in the inlet is illustrated by the noise levels shown in Figure 4.3-16. As a result of the long fan discharge ducts in the VSCE design, a substantial amount of aft fan noise attenuation is expected. The attenuation characteristics of this treatment were estimated from Pratt & Whitney Aircraft, Federal Aviation Administration, and NASA engine and rig test data. Figure 4.3-16 indicates the impact of different levels of treatment on the total engine noise level.

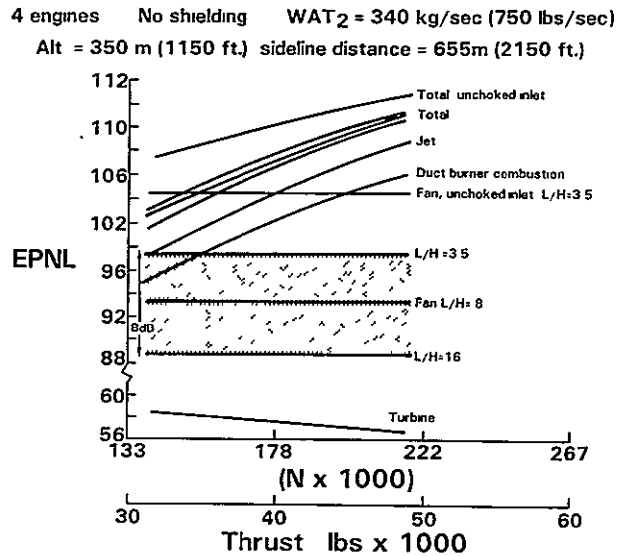

Figure 4.3-16 VCE-502B Sideline Noise Update - As shown, turbine noise is insignificant, fan noise has a slight effect on total noise, depending on the level of acoustic treatment (L/H) in the duct behind the fan, and combustion noise from the duct burner may have a small effect on total noise.

Calculation of main combustor noise was based on the results of a Federal Aviation Administration-sponsored analytical and test program. Although the system used is not intended for duct burner analysis and considerable extrapolation of the data base is required, preliminary predictions for duct burner combustion noise were made using this approach and the results were included in the VSCE-502B noise estimates.

Results from a revised turbine noise prediction procedure are also included in this analytical noise model. Levels of turbine noise are relatively low for VSCE configurations at takeoff, cutback and sideline, and do not contribute to the total noise at these conditions.

In estimating noise characteristics of the VSCE core spools, the takeoff condition, which involves full duct burner augmentation, was selected as the point for analysis. Because the demonstrator core is a subscale size ranging in airflow capacity from 109 to 132 kg/sec (241 to 290 lb/sec) as compared to the base engine at 340 kg/sec (750 lb/sec)*, the noise levels can be expected to differ. Therefore, noise comparisons were made with the demonstrator cycles in the subscale size as well as scaled to the base engine flow size. The predicted noise levels, as compared to the base VSCE-502B concept, are presented in Table 4.3-X. These results show that the

TABLE 4.3-X
NOISE ESTIMATES

	Design Flow Size (lb/sec)		Noise Levels (EPNdB)			
			Total	Fan	Jet	Duct Burner
VSCE-502B	340 (750)		Base	Base	Base	Base
F100 Core	132	290	-7.8	-4.3	-7.4	-8.2
F100 Core (Scaled)	340	(750)	-2.1	-0.1	-4.4	+0.1
ATEGG Core	122	268	-7.5	-7.3	-6.6	-8.8
ATEGG Core (Scaled)	340	(750)	-1.7	-0.1	-3.4	+0.2
EEE Core	109	241	-7.1	-7.7	-5.6	-9.7
EEE Core (Scaled)	340	(750)	-1.2	-0.1	-2.1	+0.1

*NOTE: From the results of the current engine/airframe integration studies, the representative size for the VSCE-502B is 340 kg/sec (750 lb/sec) for the FAR Part 36 noise level. Therefore, the noise estimates are for this engine size and not the 408 kg/sec (900 lb/sec) size used in assessing performance characteristics.

subscale engines in all cases are quieter than the base engine. These differences are attributed to size effects. However, if scaled to a constant thrust, noise levels would be comparable to the base engine. Therefore, as demonstrated by the data, noise characteristics are readily scalable to provide a meaningful demonstration regardless of the engine configuration and size.

4.3.5 Installation Analysis

An analysis was conducted for the purpose of reviewing the nacelle requirements for a demonstrator engine. This included determining the effect of engine size on accessories and controls packaging and nacelle wrap.

The different nacelle requirements envisioned for a VSCE system are identified in Figure 4.3-17. The nacelle design must address both aerodynamic performance and engine structural support. From an aerodynamic standpoint, the engine wrap should minimize drag and friction losses to maximize the overall system performance. Structurally, the nacelle must support the engine without causing case deflections that can damage the engine as well as deteriorate performance.

The engine will require a variable geometry inlet system to modulate airflow over the anticipated flight range from static to the supersonic cruise Mach number to ensure high performance at these diversified operating conditions. The variable inlet system illustrated in Figure 4.3-17 is comprised of a translating centerbody and auxiliary air inlet doors. Alternative approaches to this type of system could include a folding bi-cone inlet or a two-dimensional inlet. Although selection of a final system would be contingent on further study and testing, the inlet must be responsive to prevent inlet unstart or provide rapid recovery in the event this phenomenon is encountered. Noise constraints may require either acoustic treatment in the inlet and/or a near sonic (choked) inlet to reduce forward radiated fan noise.

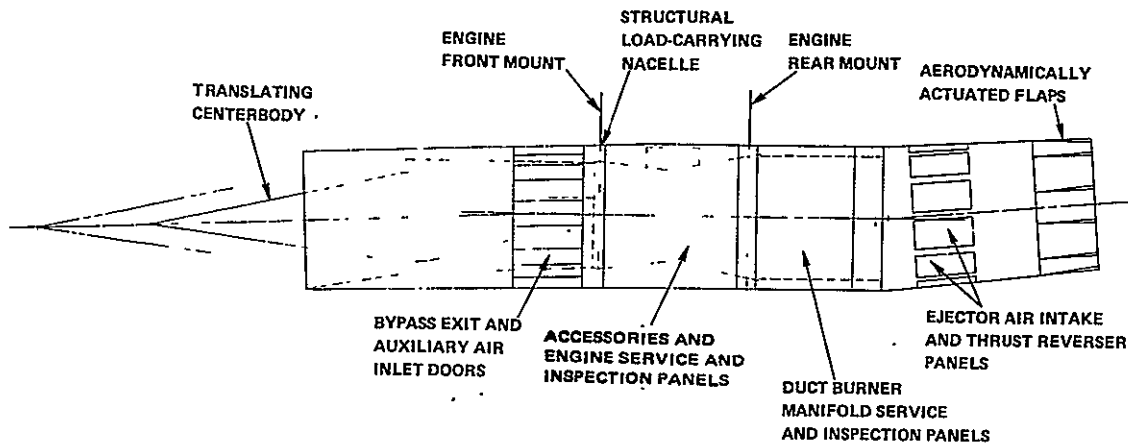

Figure 4.3-17 Nacelle and Installation Requirements for a VCE - The different nacelle and installation requirements address aerodynamic and structural considerations as well as accessibility to engine/airframe accessories for maintainability.

Besides the aerodynamic and structural factors, accessibility to the engine, controls and accessories is an important consideration to facilitate maintainability.

As part of the Phase IV effort of the NASA-sponsored Advanced Supersonic Propulsion Study, preliminary accessories packaging and integration analyses were conducted for a flight engine installation in the Boeing, Douglas and Lockheed advanced supersonic airplane concepts. The Boeing and Douglas second-generation supersonic airplane concepts utilize a conventional under wing engine installation, while the Lockheed concept employs a unique over-under wing installation arrangement. Engine installation drawings for these aircraft applications are presented in Figures 4.3-18 through 4.3-20.

In the Boeing installation, as shown in Figure 4.3-18, aircraft accessories are mounted on the wing to reduce complexity of packaging and avoid impacting the engine nacelle contour. These remote accessories such as the starter, generator and hydraulic pumps are driven

by a power takeoff unit directed from the engine to the aircraft gearbox. The reduced diameter at the intermediate case allows adequate room for engine accessories such as the oil pumps, direct burner fuel pump and full authority digital electronic control, for example, without affecting the nacelle wrap.

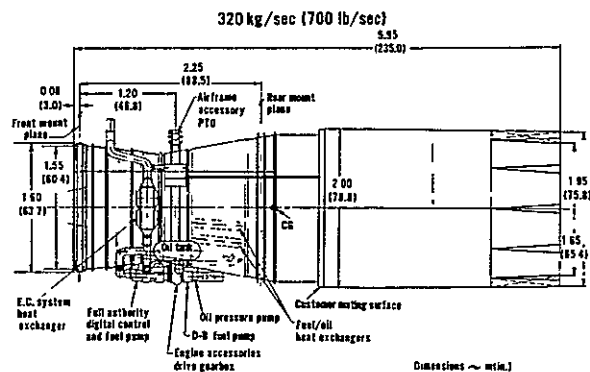

Figure 4.3-18 Boeing VSCE Installation

The Douglas installation in Figure 4.3-19 positions fuel-related accessories at the top of the engine and aircraft accessories driven through a wing-mounted aircraft gearbox. At the bottom of the engine, a second towershaft drives an auxiliary gearbox and the oil scavenge system pump. This arrangement allows sufficient area for packaging the accessories.

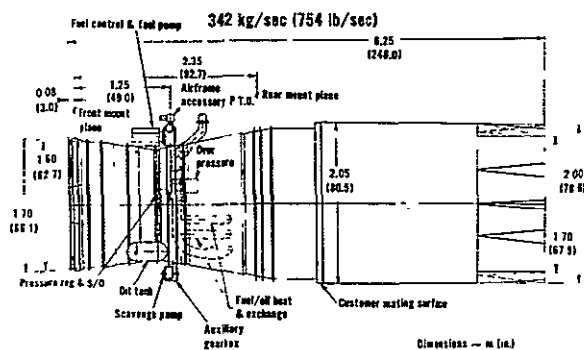

Figure 4.3-19 Douglas VSCE Installation

The Lockheed installation shown in Figure 4.3-20 locates the larger engine and airframe accessories in the wing pylon. The remaining engine accessories are positioned on the outer engine case in the region of reduced diameter. This approach provides adequate room for the accessories and does not introduce any problems with the nacelle wrap.

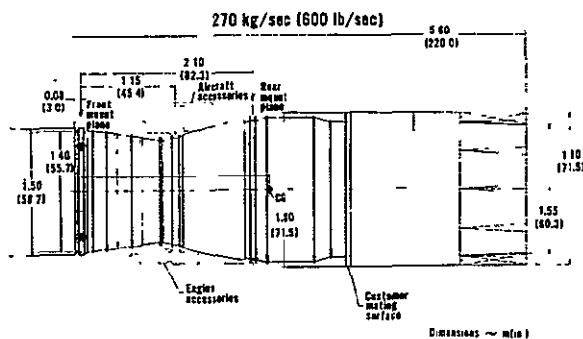

Figure 4.3-20 Lockheed VSCE Installation

Accessory requirements and size do not scale directly with engine size. Consequently, this has the potential of making the wrap and installation more difficult for a smaller engine. Since the subscale demonstrator engines are approximately one third the size of the engine concepts used during the Phase IV Integration Studies, the base engine was scaled to a demonstrator size of 113 kg/sec (250 lb/sec) and the accessories packaging was studied.

In this evaluation, selection of accessories and size was relatively conservative and restricted to either "off-the-shelf" or easily fabricated items. The resulting packaging arrangement is shown in Figure 4.3-21. This arrangement assumes that all aircraft accessories are located in the wing or pylon and driven by a power takeoff unit on the engine. As indicated by this figure, the positioning of the accessories should not impart any problems with the wrap. Components such as the fuel/oil cooler, variable vane actuators and exciter boxes, for example, are not shown in Figure 4.3-21 since these units are relatively small size and would not affect the nacelle diameter.

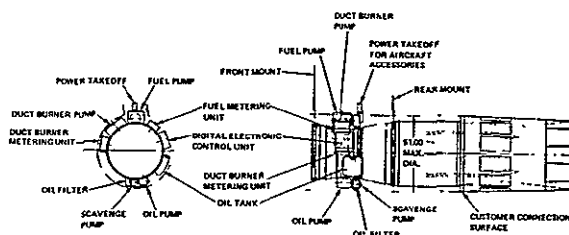

Figure 4.3-21 Subscale Demonstrator Packaging Arrangement - As shown, all accessories are contained within the engine envelope and do not present any impact on the nacelle wrap.

Locating the main fuel pump on top of the engine was governed by two factors. First, as a safety consideration, this eliminates fuel spillage in the event of a wheels-up landing. Second, the required size of this pump necessitates placement in the area of the pylon in order to minimize the impact to the nacelle contour.

The digital electronic control unit shown is based on near term technology and is a fuel-cooled, single-channel design with selective redundancy. The use of a breadboard control for a demonstrator engine would require removal of the breadboard unit from the immediate engine location shown in Figure 4.3-21.

4.3.6 Selected Demonstrator Engine Configurations

On the basis of results obtained from the configuration study, performance analyses and installation analysis, the most attractive demonstrator configurations were selected. The selected configurations are listed in Table 4.3-XI. At this time and based solely on these preliminary results, it is inappropriate as well as beyond the scope of work planned for this study to select a sole final configuration. Such a selection must follow a thorough NASA/Pratt & Whitney Aircraft review of specific program goals.

TABLE 4.3-XI

SELECTED DEMONSTRATOR ENGINE APPROACHES

New Advanced Technology Demonstrator Engine

- Subscale Size 113 to 136 kg/sec (250 to 300 lb/sec)
- Full Size 272 to 408 kg/sec (600 to 900 lb/sec)

ATEGG Core Demonstrator Engine 113 to 122 (250 to 270 lb/sec)

- Scaled VSCE-502B Low-Pressure Spool
- Scaled APSI Fan and New Low-Pressure Turbine

F100 Core Demonstrator Engine 131 kg/sec (290 lb/sec)

- Scaled VSCE-502B Low-Pressure Spool

4.4 VARIABLE CYCLE ENGINE TECHNOLOGY (VCET) PROGRAMS

4.4.1 Introduction

Plans for VCET Programs were formulated by outlining a logical sequence for verifying the different critical component technologies. Potential demonstrator programs were defined based on the use of the different approaches listed in Table 4.4-I. As shown in this table, the programs are categorized into five major areas which vary in depth of technology achievement.

TABLE 4.4-I

VARIABLE CYCLE ENGINE TECHNOLOGY PROGRAMS

- A. HIGH TEMPERATURE VALIDATION PROGRAM
- B. CORE TECHNOLOGY PROGRAMS
 - B.1 All New Hardware
 - B.2 Modified ATEGG Core (New HPT)
- C. ENGINE DEMONSTRATOR PROGRAM
 - C.1 All New Hardware
 - C.2 Modified ATEGG Core (New HPT)
 - C.3 Modified ATEGG Core/Scaled APSI Fan
 - C.4 F100 Core
- D. TECHNOLOGY READINESS PROGRAM
- E. REDUCED COST DEMONSTRATOR PROGRAMS
 - E.1 F100 Core
 - E.2 ATEGG Core/Scaled APSI Fan

The minimum recommended effort would be a High Temperature Validation Program (A). The Core Technology Programs (B) include Program (A) and offer the inherent advantage

of a low cost demonstration of key high temperature components at representative operating conditions without the added development complexity of a full engine. This allows a concentrated effort on the critical high spool core. Further basic research with the unique coannular nozzle and duct burner technologies would be pursued under parallel efforts such as a follow-on to the VCE Testbed Program. In addition to a High Temperature Validation and a Core Program, the Engine Demonstrator Programs (C) would test the critical low spool components, the VSCE concept, and evaluate the unique nozzle and duct burner components. Integration of a new core spool with the new low spool into a full engine technology demonstrator would lead to the verification of technology readiness (Program D) and provide the confidence to proceed with full engine development.

4.4.2 Definition of VCET Programs

In organizing program plans for technology demonstration, the individual program efforts to develop a critical technology or component, as discussed in Section 4.2, were estimated for overall cost as well as scheduling. The basis for estimating the preliminary program cost and time frame was programs with a similar scope of work either in progress, recently completed or being proposed by Pratt & Whitney Aircraft. The estimates included costs for management and NASA reporting requirements, in addition to the cost of money, general and administrative (G&A) costs, and fee. Cost estimates for hardware fabrication and procurement assumed the use of standard Pratt & Whitney Aircraft experimental quality assurance practices.

Unless otherwise specified in this report, all estimates reflect 1979 dollars for flexibility in the event of schedule changes. Estimates are also given in "then-year" dollars and reflect a 7 percent escalation per year. Furthermore, the

total program costs represent only effort performed by Pratt & Whitney Aircraft and do not include costs for use of government test facilities or work performed by airframe contractors concerning integration studies.

Synthesizing the technology requirements with the particular demonstrator engine configurations resulted in a selection of five program approaches that varied in terms of total program cost and technology demonstration. A network indicating the structuring and interrelationship of these programs, including different engine configuration options, is presented in Figure 4.4-1. Also, an overview of the different program elements comprising this network is presented below. A more comprehensive description of these programs and individual program options is contained in the following section.

- **High Temperature Validation Program** — This program is structured as a minimum cost effort that concentrates on demonstrating VCE technologies most critical to a second-generation, supersonic transport propulsion system. As defined, the level of work involves extended testing in the current VCE Testbed Program, expanded duct burner rig tests, and additional coannular nozzle noise and performance tests. Critical high temperature technologies would be demonstrated as part of a high-pressure spool diagnostic test.
- **Core Technology Programs** — With additional funding, the preceding High Temperature Validation Program would be amplified to include development of all of the high spool technologies. This work could be accomplished by using the modified ATEGG core as a base vehicle or by developing a new core with advanced technologies.

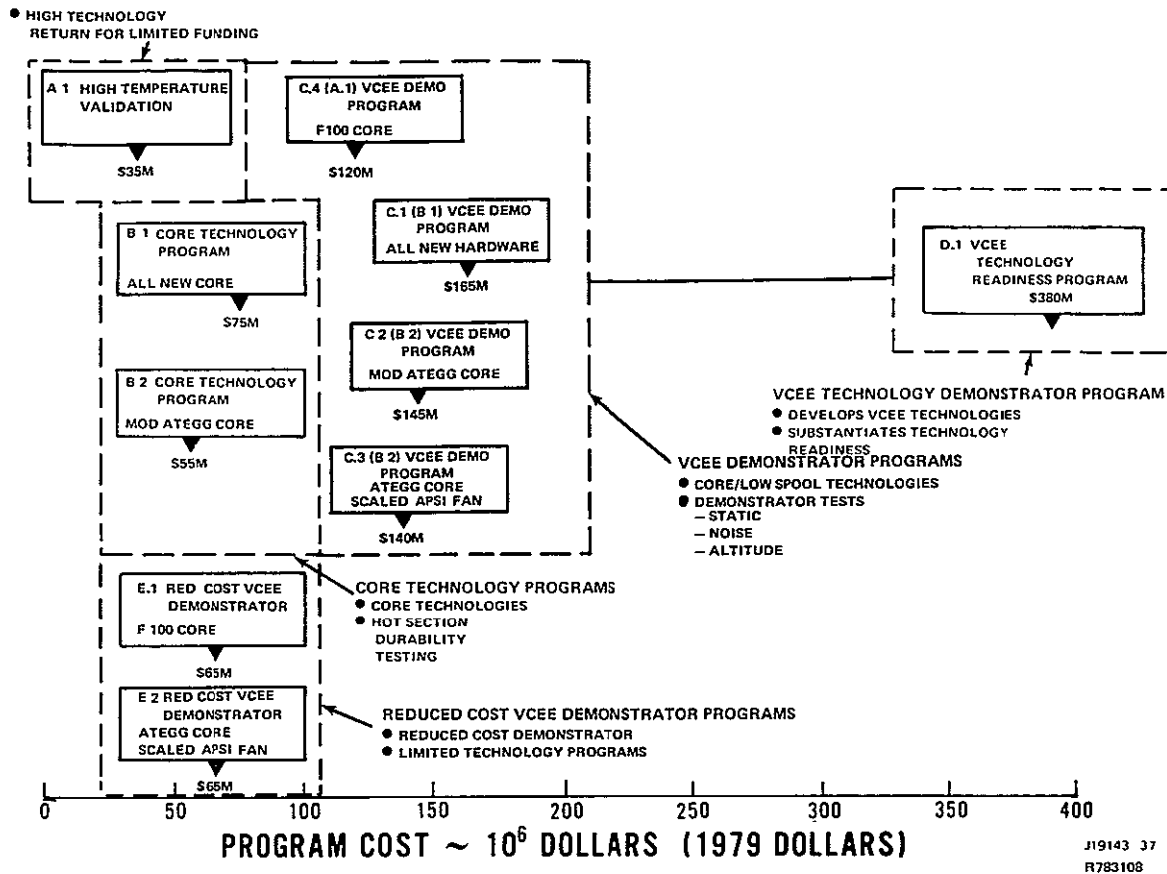

Figure 4.4-1 VCEE Program Network - Within the five basic program categories, the level of funding and technology demonstration varied considerably.

- **Engine Demonstrator Programs** — These programs build on the work described in the Core Technology Program by adding low-pressure spool technology programs. This low spool technology may be obtained either with a low spool demonstrator such as the F100 core or a full engine demonstrator with the new high spool. The scope of work would include engine performance, noise and limited durability testing.
- **Technology Readiness Program** — Although the aforementioned programs provide a demonstration of critical technologies, additional component and engine testing would be necessary to acquire the level of confidence to proceed with full engine develop-

ment. The objective of this program would be to achieve this level of confidence through accelerated component and technology programs and continued experimental engine testing, especially in the areas of performance and durability.

These different programs summarized include experimental engine testing at sea level and simulated altitude conditions. Additional tests with the advanced demonstrators such as wind tunnel or flight testing are considered as a follow-on effort to the basic programs listed above.

- **Reduced Cost Demonstrator Programs** — These programs are structured to utilize either the ATEGG or F100 core spools,

without modification, and a minimum of individual component technology development to provide a relatively low cost engine program to demonstrate the VCE cycle concept. This vehicle could then be used to demonstrate the remaining technologies at a later date. These programs are not as cost effective as the preceding programs (A-D) from a technology demonstration standpoint.

4.4.3 Program Plans

The elements within the five basic program plans identified in Figure 4.4-1 have been structured to provide an inherent degree of flexibility. From these programs, different options can be organized to achieve a logical continuity in the technology demonstration process by using selective elements. As presented, the program plans build on the lower cost programs and these lower cost programs

are wholly included in the more extensive plans. This allows for possible phasing should initial funding be limited. Although the program efforts are presented as being additive, the attendant total costs and schedules are not. As given, the program costs and schedules are complete and inclusive for the overall effort outlined for each respective program.

4.4.3.1 High Temperature Validation Program (A.1)

The High Temperature Validation Program is planned as a minimum cost effort that concentrates on demonstrating hot section, nozzle and duct burner technologies. The demonstrator vehicle for this program would be a modified ATEGG core. As shown in Figure 4.4-2, the total effort encompasses a five year period and has an estimated cost of 35 million dollars (based on 1979 dollars).

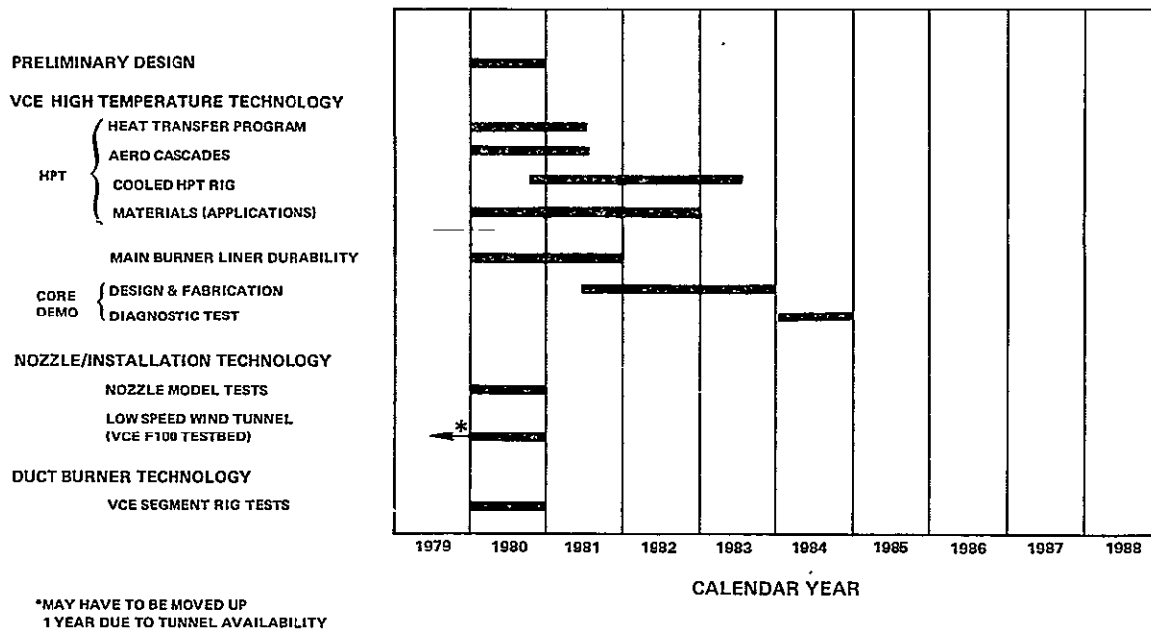

Figure 4.4-2 High Temperature Validation Program (A.1) - This program is a minimum cost approach to continue the VCE critical component effort and design, fabricate and substantiate advanced supersonic high-pressure turbine technology using a modified ATEGG core. (Cost: \$35M in 1979 dollars or \$42M in then year dollars)

As planned, the current Aero/Acoustic Nozzle Model Test Program, Duct Burner Experimental Rig Test Program, and VCE Testbed Program would continue through 1979. Under this program, additional duct burner development testing to optimize emissions and performance would be required as well as additional nozzle model testing, as indicated in Figure 4.4-2. Wind tunnel testing of the VCE F100/testbed would provide acoustic characterization of forward speed flight effects for a complete substantiation of the coannular noise benefit.

A preliminary design effort is scheduled and would involve approximately a one-year period. This work would focus on defining the flight engine design as well as the preliminary design configuration of the demonstrator engine. Because of the limited funding, work pertaining to the core demonstrator would be directed towards optimizing the high temperature technologies.

The high temperature technology effort mainly addresses the high-pressure turbine. Work would include heat transfer and aerodynamic cascade programs, design of a high-pressure turbine for the core demonstrator, and rig testing of the turbine component. Work involving the main combustor would be aimed at durability and address the problems of burner liners for commercial application.

The program would culminate with diagnostic testing using a modified ATEGG core as a demonstrator. The compressor and combustor would conform to ATEGG technology, while the turbine would incorporate VCE technology requirements. The core demonstrator diagnostic test would be specifically directed at assessing the performance and durability of the turbine component.

4.4.3.2 New Advanced-Technology Engine Demonstrator Programs

In this category, there is a total of three different programs which range from the design and

testing of an advanced technology core demonstrator to a complete technology readiness program. These programs are identified within the overall program matrix in Figure 4.4-3 and discussed in the following paragraphs.

Core Technology Program (B.1)

The Core Technology Program is an extension of the High Temperature Validation Program and provides a comprehensive effort to develop and test a high-pressure spool utilizing advanced technology concepts. The scope of work in this program is outlined in Figure 4.4-4, and based on 1979 dollars, the estimated cost is 75 million dollars. As indicated in Figure 4.4-4, the main area of emphasis would be the high-pressure spool, particularly the hot section. However, part of the effort would be directed towards developing duct burner and nozzle/installation technology.

A preliminary design effort, which is scheduled for two years, would proceed to optimize the VSCE flight concept and demonstrator engine with special attention on the core demonstrator design. This work would continue through the core component design and early experimental rig tests in order to refine the core spool design-definition.

In the area of high temperature technology development, programs for the high-pressure turbine are similar in scope to those in the High Temperature Validation Program, except for the addition of a Heat Exchanger Program and a uncooled rotating rig test. The turbine configuration resulting from these programs would be designed to optimized elevation and rotor speed, rather than the parameters dictated by an existing core.

Using the results of the liner durability program, main combustor emissions and performance would be developed through sector rig testing. The combustor aerothermal-mechanical configuration would be refined and proof tested in a full annular combustor rig prior to evaluation in the core spool.

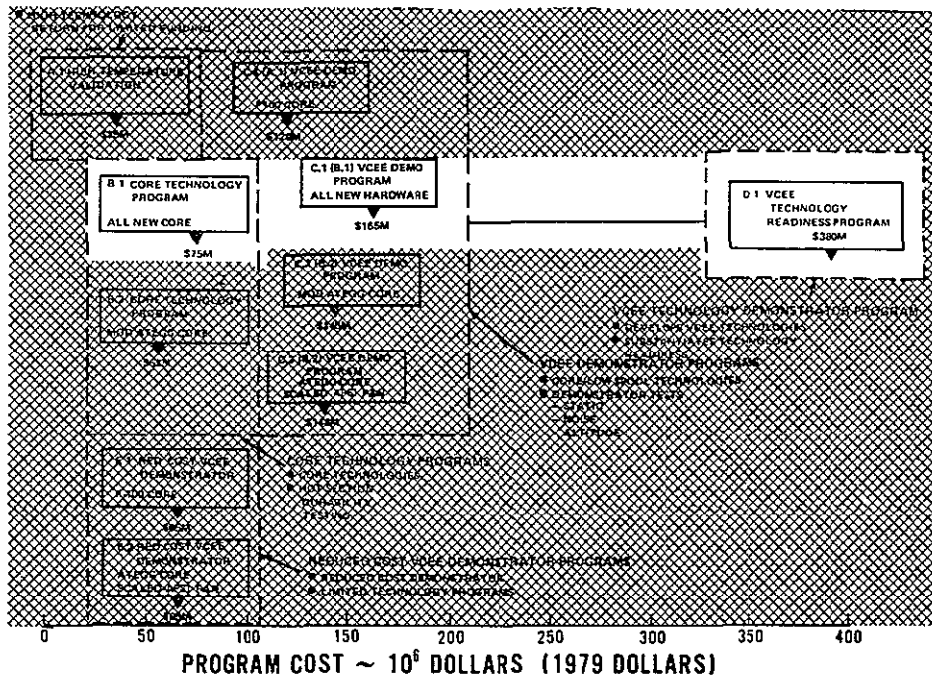

Figure 4.4-3 VCET Programs Based on All New Advanced Technology Hardware – These programs are based on using component concepts and a level of technology that most closely approximates the flight engine configuration.

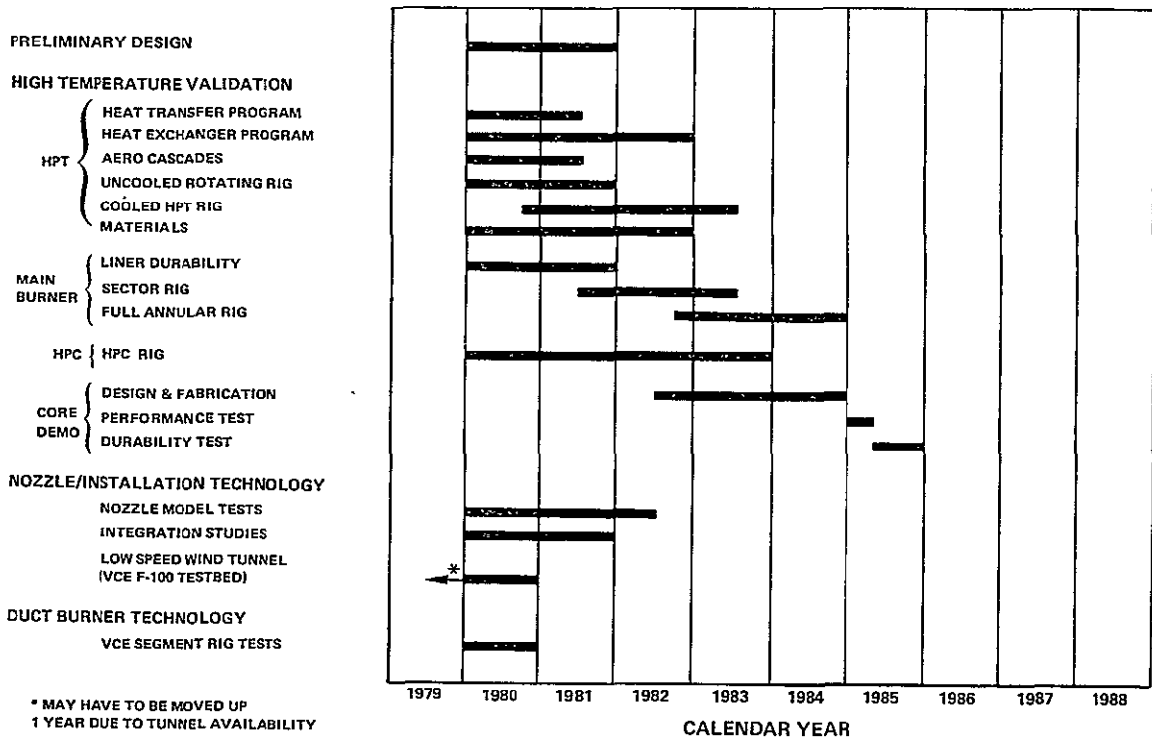

Figure 4.4-4 Core Technology Program (B.1) Schedule - This program consists of developing and testing new advanced-technology core components. (Cost: \$75M in 1979 dollars or \$92M in then year dollars)

In a similar manner, the high-pressure compressor would be designed and rig tested before evaluation in the core demonstrator vehicle. The scheduling for this work has allowances for airfoil modification during the test series in order to optimize compressor performance.

Following the design and fabrication of core spool components, a series of core demonstrator tests would be conducted to evaluate and demonstrate the critical core component technologies. A performance evaluation is the first of the scheduled tests, and then a limited durability evaluation would be conducted at an elevated compressor inlet temperature and pressure to simulate critical VCE operating conditions.

A part of the effort in the Core Technology Program would focus on developing coannular nozzle and duct burner technology. Model tests would be performed with an integrated coannular nozzle with the objective of optimizing the nozzle aerodynamic configuration based on installed performance and demonstrating the overall performance potential of the integrated nozzle system. Also, integration studies would be conducted to furnish key information relating to airframe designs as well as the performance potential of the overall flight system. Finally, low-speed wind tunnel jet noise testing of the VCE testbed would be conducted, along with additional duct burner segment rig tests.

Engine Demonstrator Program (C.1)

A program for a new advanced-technology engine demonstrator would build on the Core Technology Program. However, the overall magnitude of work would be amplified substantially to permit developing all the technologies for the low-pressure spool, duct burner, coannular nozzle, and controls system. As indicated in Figure 4.4-5, the planned program is nearly a seven-year effort and the total estimated cost is 165 million in 1979 dollars.

The various elements of the Core Technology Program have been wholly assimilated into this program plan, as shown in Figure 4.4-5, and effort added. The most apparent area is the expanded materials development programs for the high-pressure turbine. Also, the preliminary design work and integration studies have been moderately expanded, commensurate with the scope of work in the overall program.

In the area of the duct burner, the effort would be organized towards developing a viable system for the demonstrator engine. The liner durability and diffuser programs would provide the basis for rig emissions and performance development testing. Full size sector rig testing would demonstrate the aerothermodynamic and emissions characteristics of the duct burner for the flight system.

Developing the necessary low-pressure spool technology would involve a five-year effort. The fan design would be predicated on the results of rig and cascade tests. Component refinement and verification would be accomplished as part of a fan component rig test prior to engine evaluation. This same design approach would be employed to develop the low-pressure turbine system.

A six-year development effort is planned to develop the full authority electronic control system for a VCE. However, to reduce program cost a breadboard control would be used during demonstrator engine testing.

Demonstrating the interactive performance effects of the core, low-pressure spool, duct burner, nozzle and control components would be accomplished in a series of full engine demonstrator tests, including performance, noise and altitude chamber testing. The engine configuration used to demonstrate these technologies would as closely as possible duplicate the flight engine concept. For example, a new duct burner close-coupled to the fan with a short diffuser would be used along with a fully variable coannular exhaust nozzle, including ejector and reverser.

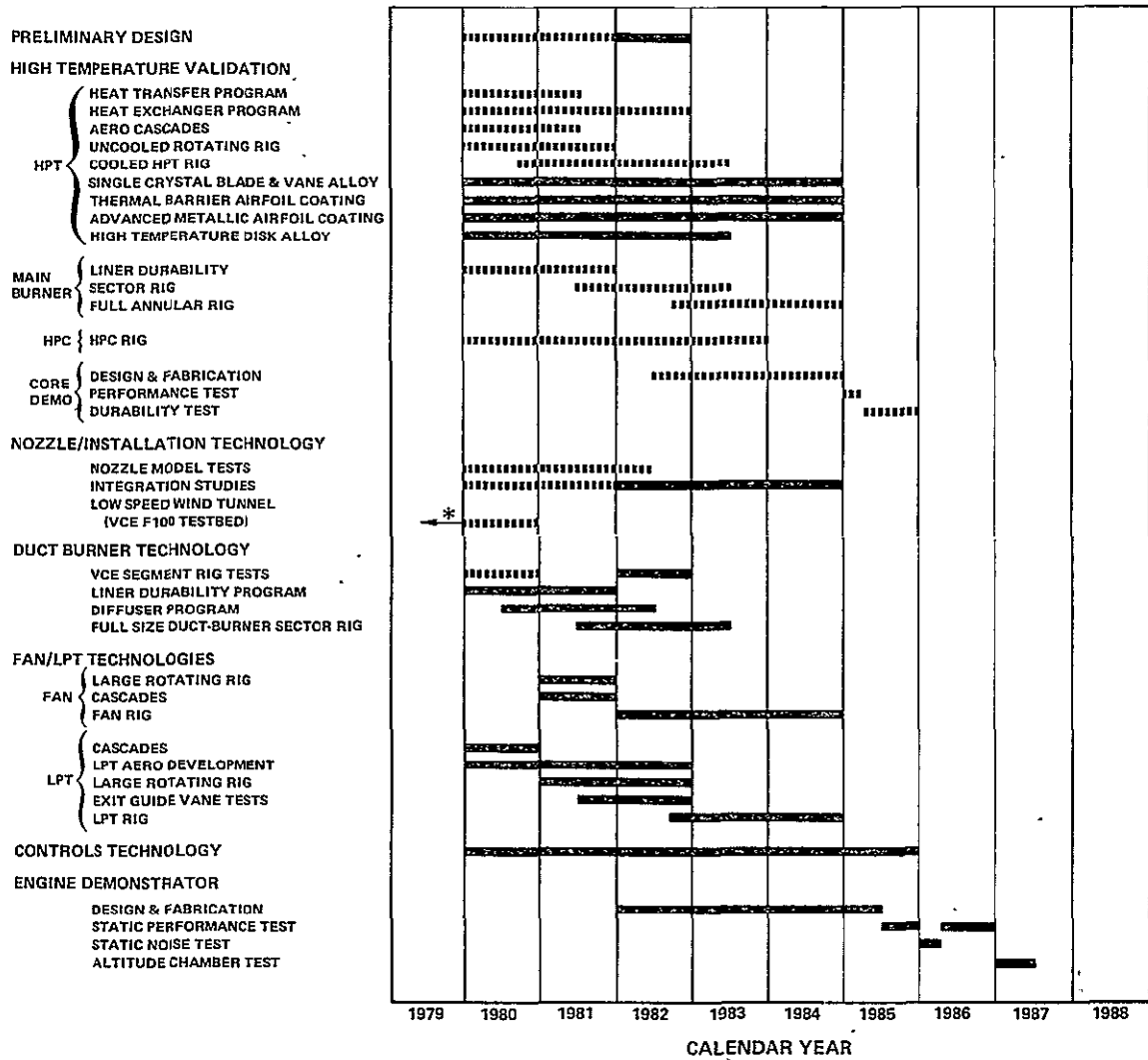

Figure 4.4-5 Demonstrator Engine Program (C.1) Schedule - In this effort, a new advanced technology demonstrator engine will be designed, fabricated and tested for performance, noise and durability. (Cost: \$165M in 1979 dollars or \$218M in then year dollars)

The test plan for technology verification consists of two performance evaluations, separated by a static noise test, then an altitude chamber test. The performance tests would assess component and integrated system effects at sea level static conditions and the noise test would provide a comprehensive examination of the total engine acoustic characteristics. Testing at simulated altitude conditions at the Pratt & Whitney Aircraft Andrew Willgoos Turbine Laboratory would enable duplicating key operating conditions such as supersonic cruise.

Technology Readiness Program (D.1)

Achieving technology readiness, the confidence to proceed with full engine development, requires additional technology development and experimental testing beyond that accomplished in the previous Engine Demonstrator Program (C.1). The program outlined for achieving technology readiness is shown in Figure 4.4-6. The areas reflecting the additional effort are the materials development programs and the increased number of experimental core and full engine demonstrator tests. The total estimated cost of this effort is 380 million in 1979-dollars.

The Engine Demonstrator Program (C.1) would be used as the foundation of the Technology Readiness Program, as indicated in Figure 4.4-6, except that initial testing of the demonstrator engine would incorporate an F100 core prior to running the Full Engine Demonstration with the all new advanced technology core.

In addition to being a cost effective method, using a proven core spool would allow early demonstration of the low spool components. This low spool demonstrator would also be used to refine the duct burner design for the full demonstration engine using all new advanced technology core hardware.

Technology programs, on a component basis, would be increased in scope to allow a redesign of the component in order to incorporate design refinements. Results acquired from initial core demonstrator tests and the F100 core low spool demonstrator engine tests would serve as the basis for design substantiation or modification. The resulting second-generation core and full engine demonstrator configurations would utilize the design improvements and advanced materials developed during the early effort paralleling the initial tests.

The Core Technology Program (B.1), Engine Demonstrator Program (C.1) and Technology Readiness Program (D.1), as outlined in the previous paragraphs, are predicated on a subscale demonstration vehicle in the 113 to 136 kg/sec (250 to 300 lb/sec) airflow size. The same programs, however, could be conducted using a demonstrator vehicle in the 272 to 408 kg/sec (600 to 900 lb/sec) size, the size envisioned for a flight engine. If a larger size demonstrator was selected, additional funding would be required along with allowances in the program schedule. The estimated impact of these variables is shown in Table 4.4-II for the three new technology vehicle programs.

For the Core Technology Program, the additional cost is predominately related to the increase in hardware size. Although this is a contributing element in the remaining programs, there is the intervention of other factors that substantially increases cost. As one example, use of a scaled fan rig, which is necessary because of facility limitations, precludes use of that rig hardware for the full additional fan design and fabrication effort thereby increasing costs sharply and delaying the test date by as much as two years. For these reasons, the use of a subscale demonstrator is the preferred approach.

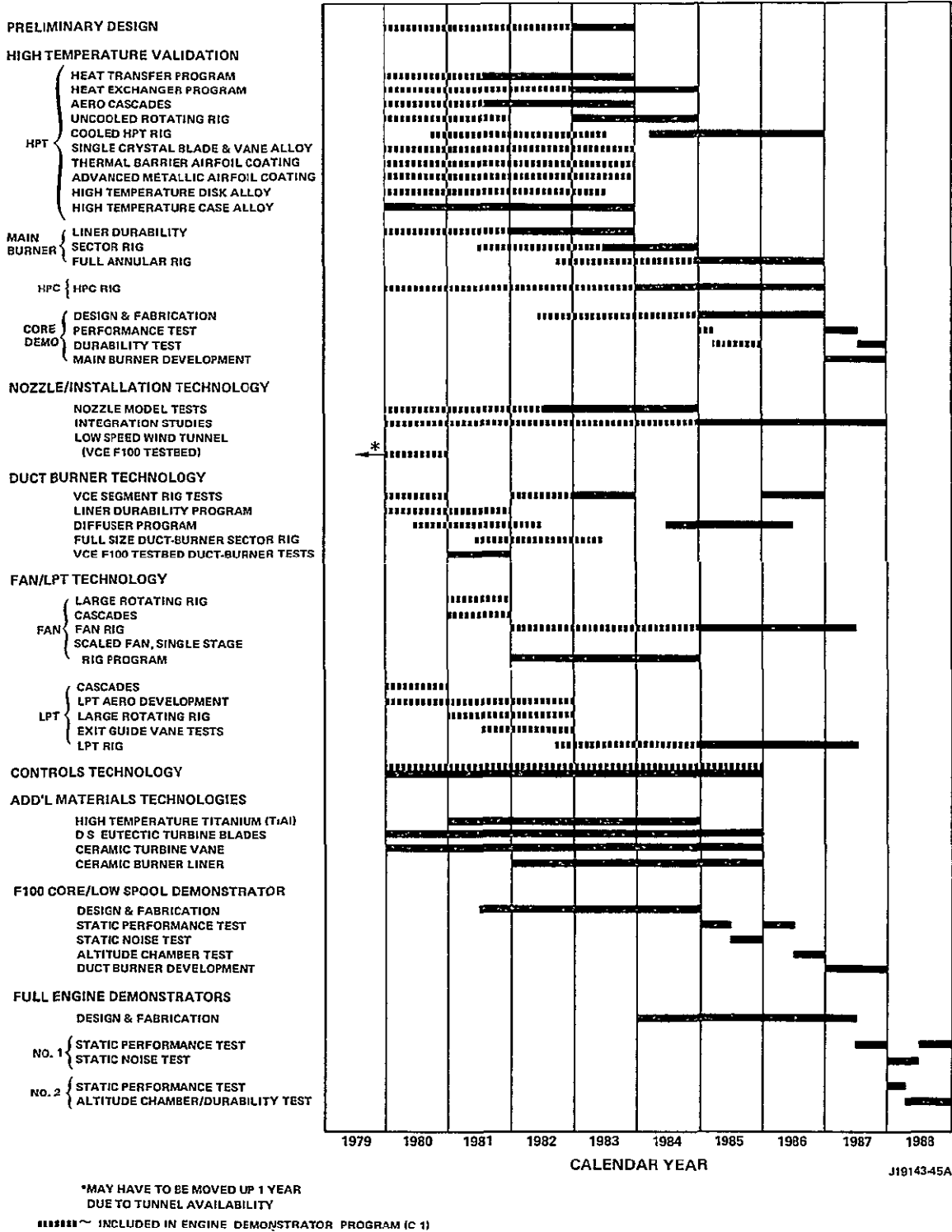

Figure 4.4-6 Technology Readiness Program (D.1) Schedule - The additional technology development and experimental engine testing planned in this program will provide the necessary prerequisite to proceed with a full engine development program. (Cost: \$380M in 1979 dollars or \$549M in then year dollars)

Core Technology Program (B.2)

The Core Technology Program expands the effort in the basic High Temperature Validation Program discussed in Section 4.4.3.1. The scope of work planned in this program is shown in Figure 4.4-8, and the estimated cost for this effort is 55 million in 1979 dollars.

The program content is essentially the same as that for the new advanced-technology core except for omission of high compressor and much of the main combustor technology programs. These components would be based on ATEGG designs. Although these components must still be fabricated, a significant cost savings could be attained by eliminating the detailed design effort and component verification tests.

The thrust of this program would be directed at designing and testing a high-pressure turbine

component, but effort would be expended in the area of combustor liner durability improvement including modifications to the ATEGG burner liners. Testing the modified ATEGG core demonstrator would first be conducted at sea level static conditions for a comprehensive performance assessment, followed by a limited durability evaluation at elevated inlet pressure and temperature to simulate critical VCE operating conditions.

Engine Demonstrator Program (C.2)

The Engine Demonstrator Program is based on the use of the modified ATEGG core demonstrator integrated with a new low-pressure spool scaled from the base engine design. The program schedule is outlined in Figure 4.4-9. The estimated cost for this work is 145 million in 1979 dollars.

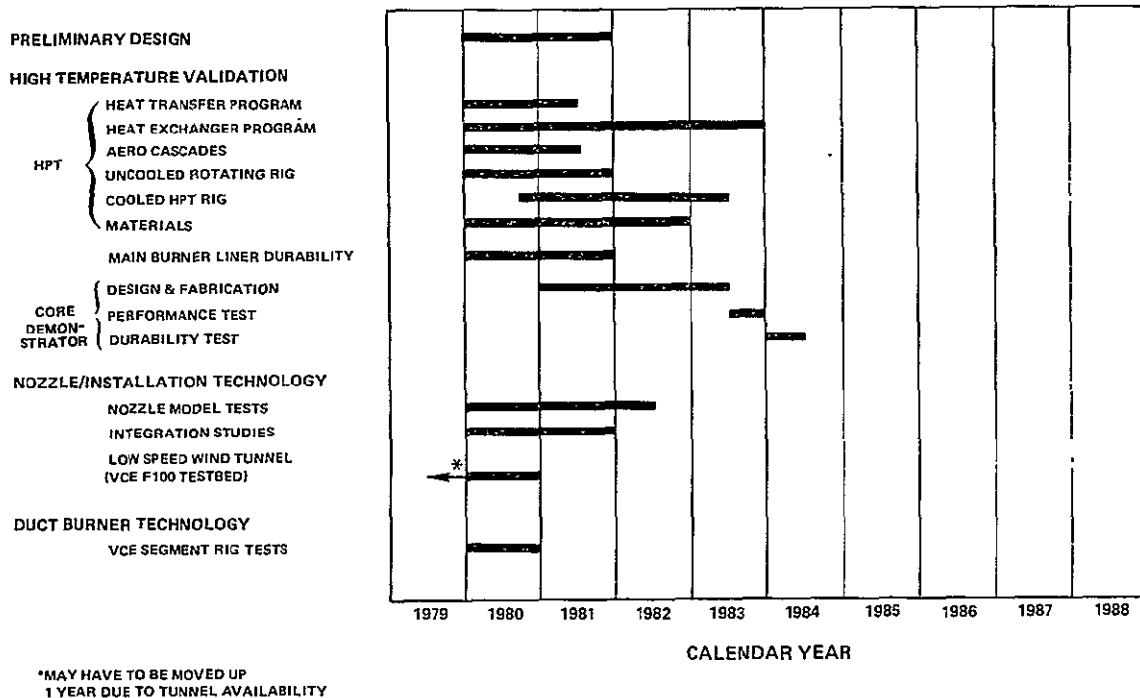

Figure 4.4-8 Core Technology Program (B.2) Schedule - This program emphasizes development of a new high-pressure turbine for testing with the ATEGG second-generation compressor and second-generation swirl-flow combustor (Cost: \$55M in 1979 dollars or \$66M in then year dollars)

The general format of the program is essentially the same as that planned for a new advanced technology demonstrator engine. The only difference is the application of a ATEGG

high-pressure spool technology, which obviates the requirement for compressor and combustor component development for a significant cost savings.

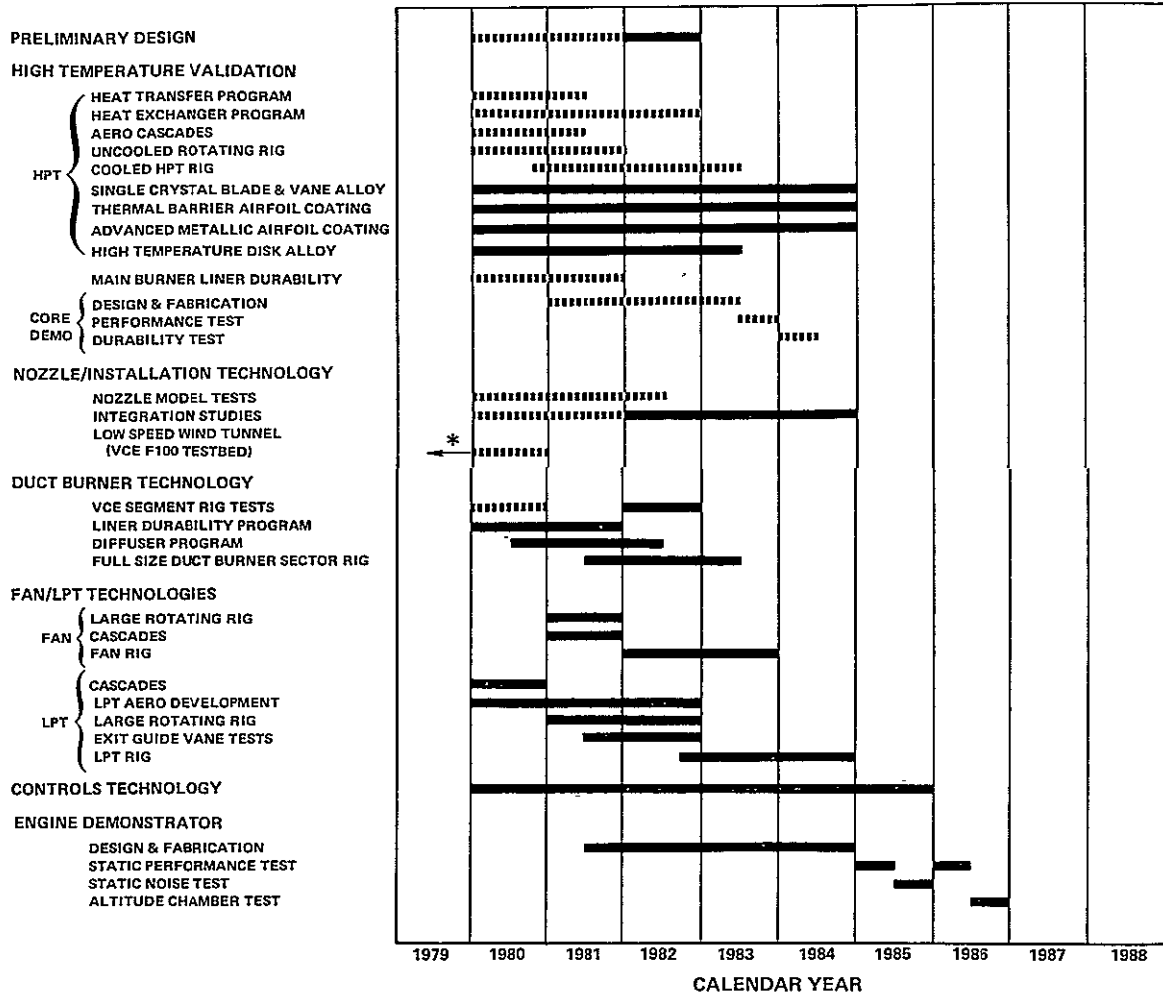

Figure 4.4-9 Engine Demonstrator Program (C.2) Schedule - The demonstrator vehicle for this program consists of a modified ATEGG core and a scaled VCEE-502B low-pressure spool. (Cost: \$145M in 1979 dollars or \$189 in then year dollars)

Demonstrator Engine Program (C.3)

The second approach to a demonstrator engine program centers around a modified ATEGG core with a scaled APSI fan. Basically, the overall content of this program is the same as the Engine Demonstrator Program (C.2) with only a variation in the area of fan development. Use of the APSI fan design, since it is a demonstrated technology, eliminates the requirement for rig testing to substantiate the aerodynamic design. This in turn provides a savings in program cost. One disadvantage, however, is that advances in fan technology for improved performance and fan noise characteristics of the VCE fan would not be evaluated with the APSI fan during this demonstrator effort.

The program plan and schedule is shown in Figure 4.4-10, and the estimated total cost is 140 million in 1979 dollars.

4.4.3.4 F100 Core Demonstrator Engine Program

A low-spool demonstrator engine program (C.4) using a F100 core and scaled VSCE-502B low-pressure spool appreciably reduces program cost and technical risk while demonstrating low spool advanced technology components. The program plan, as shown in Figure 4.4-11, is organized into two basic elements: a low-pressure spool and engine demonstration effort, and a high temperature technology core demonstrator effort. The total estimated cost of this program is 120 million in 1979 dollars.

The low-pressure spool technology development effort as well as subsequent low spool demonstrator engine tests are identical to those in the Engine Demonstrator Programs using an ATEGG core spool (C.2, C.3). As indicated in Figure 4.4-11, the spectrum of testing includes performance, acoustic and altitude evaluations.

The program elements outlined for validating the high temperature technology are similar

in substance to the basic High Temperature Validation Program (A.1).

4.4.3.5 Reduced Cost Demonstrator Programs

The Reduced Cost Demonstrator Programs are structured to emphasize demonstration of the VSCE cycle and the critical duct burner and coannular nozzle components. These programs provide only a limited demonstration of advanced technologies and do not appear to be as cost effective as the other programs (A-D) from a technology demonstration standpoint. Two Reduced Cost Demonstrator Programs were identified, predicated on using either an unmodified F100 or ATEGG core in a low spool demonstrator engine to reduce cost. Program plans based on the use of these core spools are outlined in the following paragraphs.

Reduced Cost Demonstrator Program with F100 Core

An overview of the reduced cost F100-based demonstrator program (E.1) is presented in Figure 4.4-12. The preliminary design effort would be directed towards establishing a preliminary design definition of the VSCE-502B and integration of the scaled VSCE low-pressure spool with the F100 core. Integration studies are planned to ensure the applicability of the design to the overall system requirements. Also, integrated nozzle model tests would be conducted to refine the coannular exhaust nozzle system for the low spool demonstrator engine.

Technology programs for the duct burner and low-pressure spool components would be conducted. The scope of work includes cascade as well as rig testing for verification of the low-pressure spool components prior to integration with the F100 core. To reduce cost, a technology program for the controls system would be restricted to defining system requirements for the demonstrator vehicle and use of a breadboard control during the engine test program.

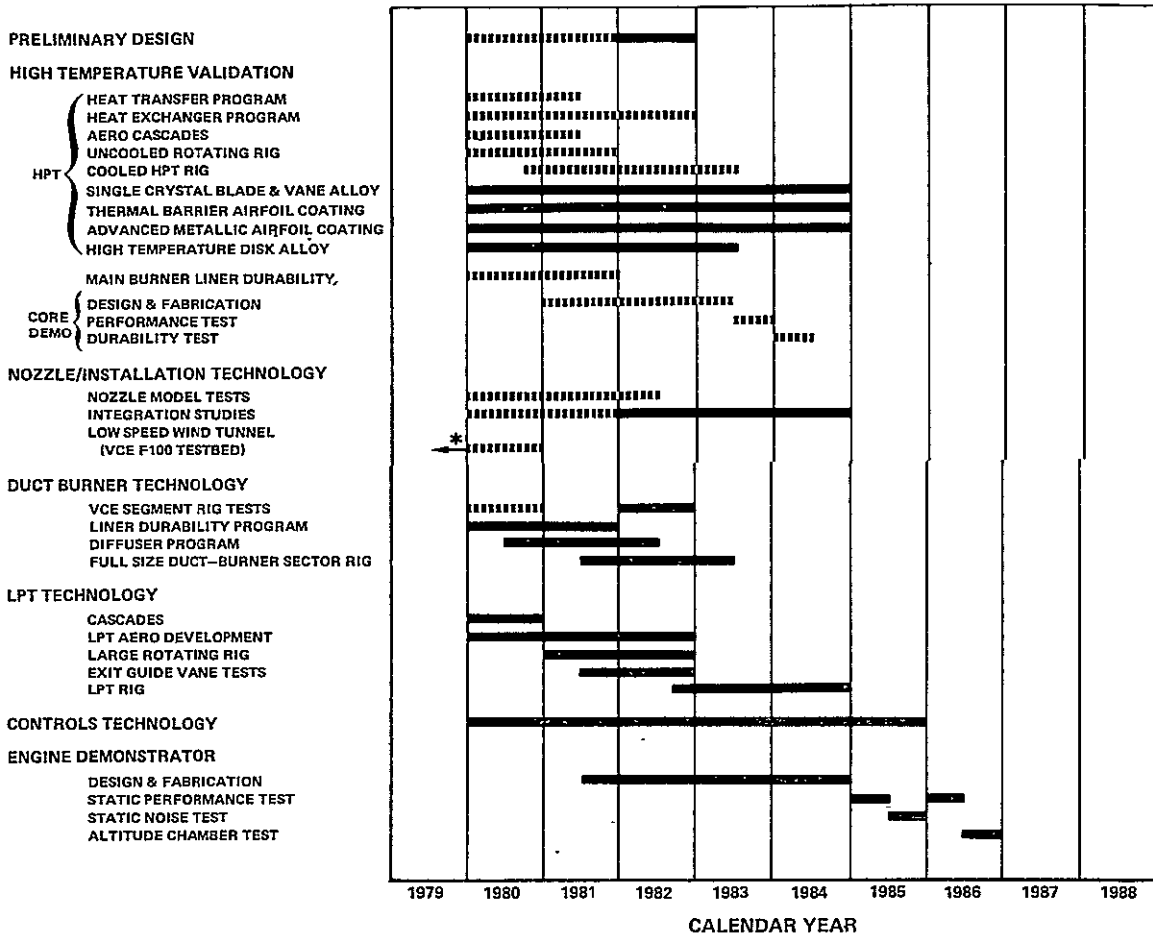
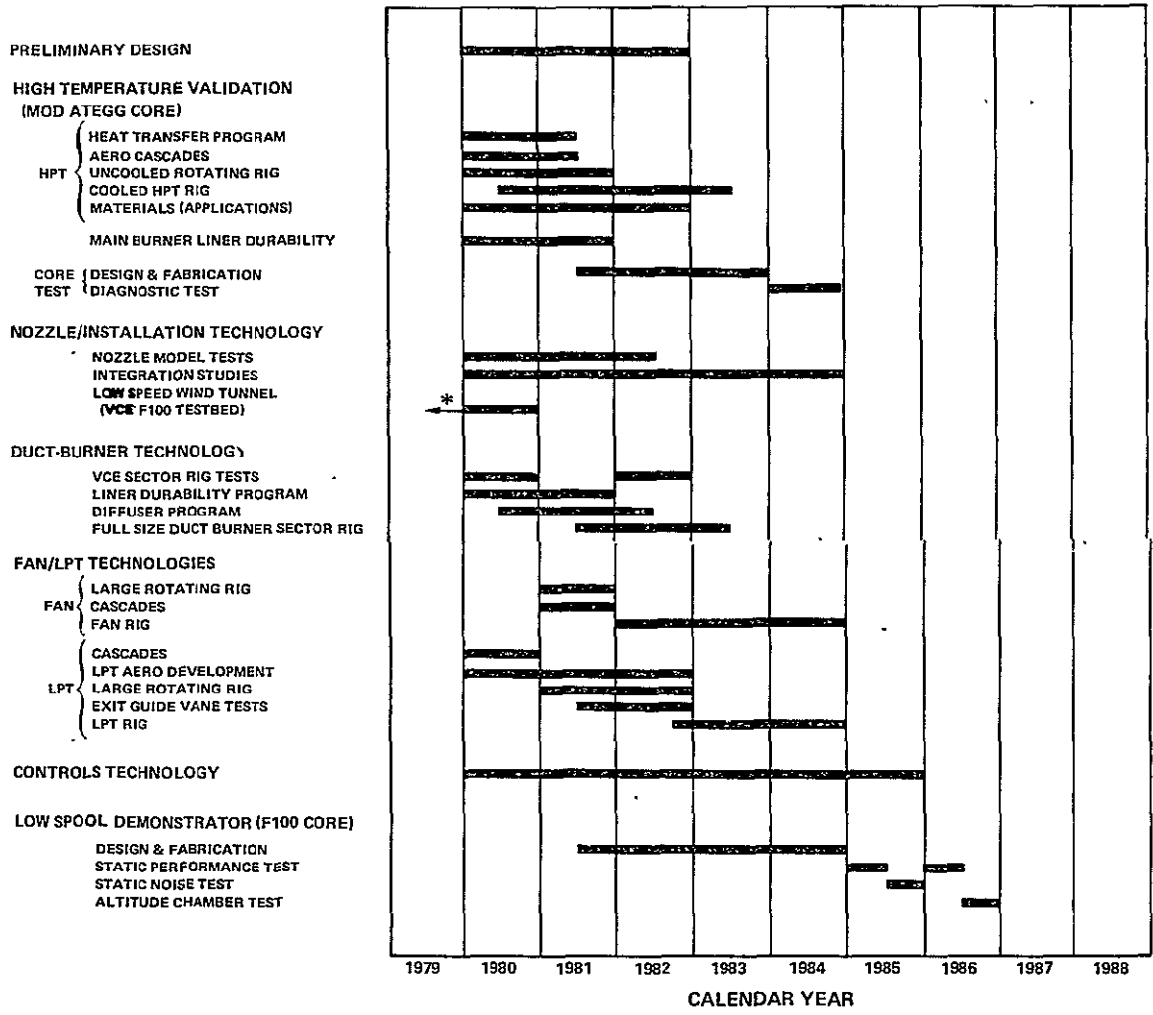

Figure 4.4-10 Engine Demonstrator Program (C.3) Schedule - Use of a modified ATEGG core and the scaled APSI fan instead of a scaled VSCE-502B fan reduces the program cost by 5 million dollars. (Cost: \$140M in 1979 dollars or \$180M in then year dollars)



*MAY HAVE TO BE MOVED UP
DUE TO TUNNEL AVAILABILITY

Figure 4.4-11 Engine Demonstrator Program (C.4) Schedule - A demonstrator engine program based on an F100 core spool is a relatively low cost and low risk approach to an engine demonstrator program. (Cost: \$120M dollars in 1979 dollars or \$158M in the year dollars).

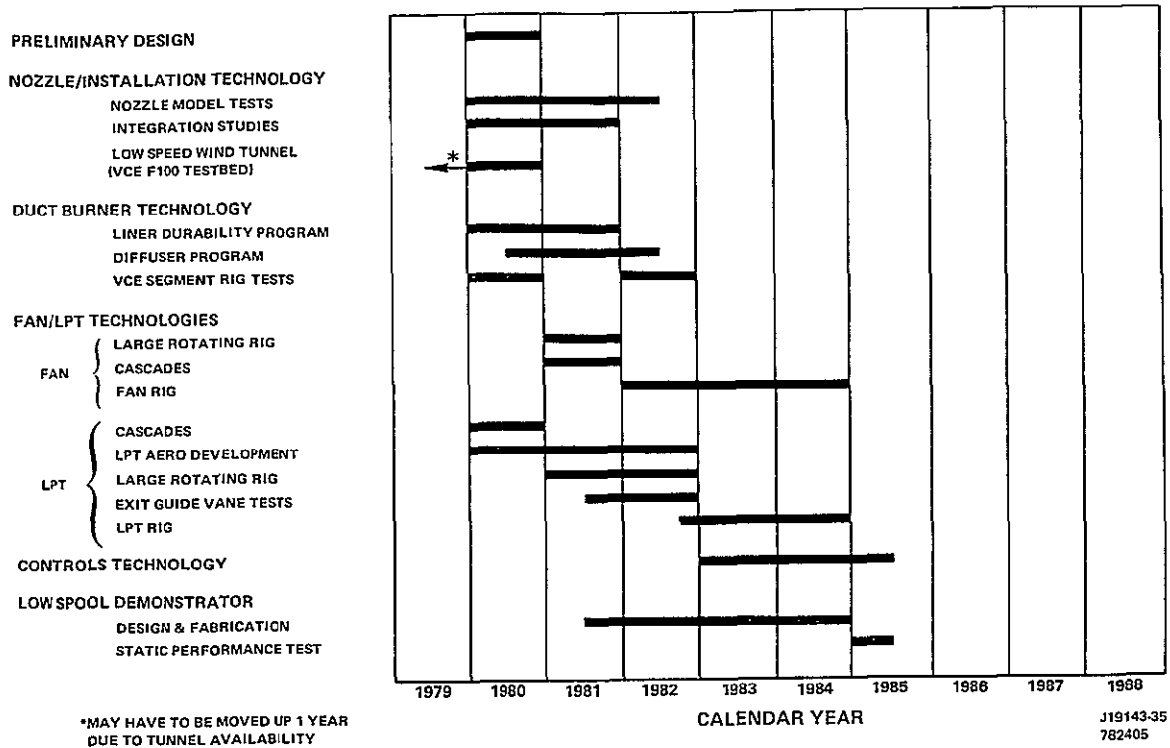

Figure 4.4-12 Reduced Cost Demonstrator Program (E.1) Schedule - Using an F100 core, this program will concentrate on demonstrating the VSCE cycle and duct burner and coannular nozzle technologies. (Cost: 65M in 1979 dollars or 84M in then year dollars)

Low spool demonstrator testing would consist of a performance evaluation at sea level conditions. At the conclusion of this program, the demonstrator vehicle could be employed as a building block technology demonstrator to assess advanced technology concepts in follow-on programs. The estimated cost of this program, based on 1979 dollars, is 65 million dollars.

Reduced Cost Demonstrator Program with ATEGG Core

The plan for a Reduced Cost Demonstrator Program using the ATEGG core (E.2) is outlined in Figure 4.4-13. The estimated cost of this effort is also 65 million dollars, since the program elements are identical to the previous

program, except that the ATEGG core would be used instead of the F100 spool and the scaled APSI fan substituted for a scaled VSCE-502B configuration. Although use of the APSI fan design is a more cost effective approach than developing the VSCE fan, the net savings over the previous program is offset by the increased cost to procure the ATEGG core in relation to the F100.

4.4.3.6 Follow-On Test Options

Program plans have been defined to complete the technology substantiation process through sea level and altitude performance testing. Although this testing is sufficient to demonstrate the various advanced technology con-

cepts, additional specialized types of tests could be required before proceeding with a full scale engine development program. Two optional test programs are a wind tunnel test and a flight evaluation. Both of these options are described in the following paragraphs.

Demonstrator Engine Wind Tunnel Test

A low-speed wind tunnel test of a demonstrator engine would enable a thorough evaluation of engine acoustic characteristics with forward flight speed effects. This test was not included in a basic program plans since a similar test is recommended early with the VCE testbed. In the event that the early testbed wind tunnel test engine does not materialize or additional wind tunnel testing is required, this optional test would be a suggested follow-on effort.

In this program, a nonflightweight nacelle or engine wrap would be required for the demonstrator engine and testing would be con-

ducted with either a subsonic inlet or a variable geometry inlet constructed from experimental hardware. Although adding complexity to the test program, the use of a variable geometry inlet would permit measuring engine noise with a near sonic inlet configuration. However, it is recommended that these effects be accounted for by using a fixed subsonic inlet with an analytical correction. The estimated cost of the optional wind tunnel program, depending on the type of nacelle and inlet geometry, ranges from 2 to 5 million in 1979 dollars.

Flight Test Program

Flight testing a demonstrator engine at key operating conditions, especially in the Mach 2+ regime, would provide a demonstration of the interactive effects of the inlet and nacelle with the engine. Although flight testing is beneficial, it is not necessary for substantiating the engine technology readiness.

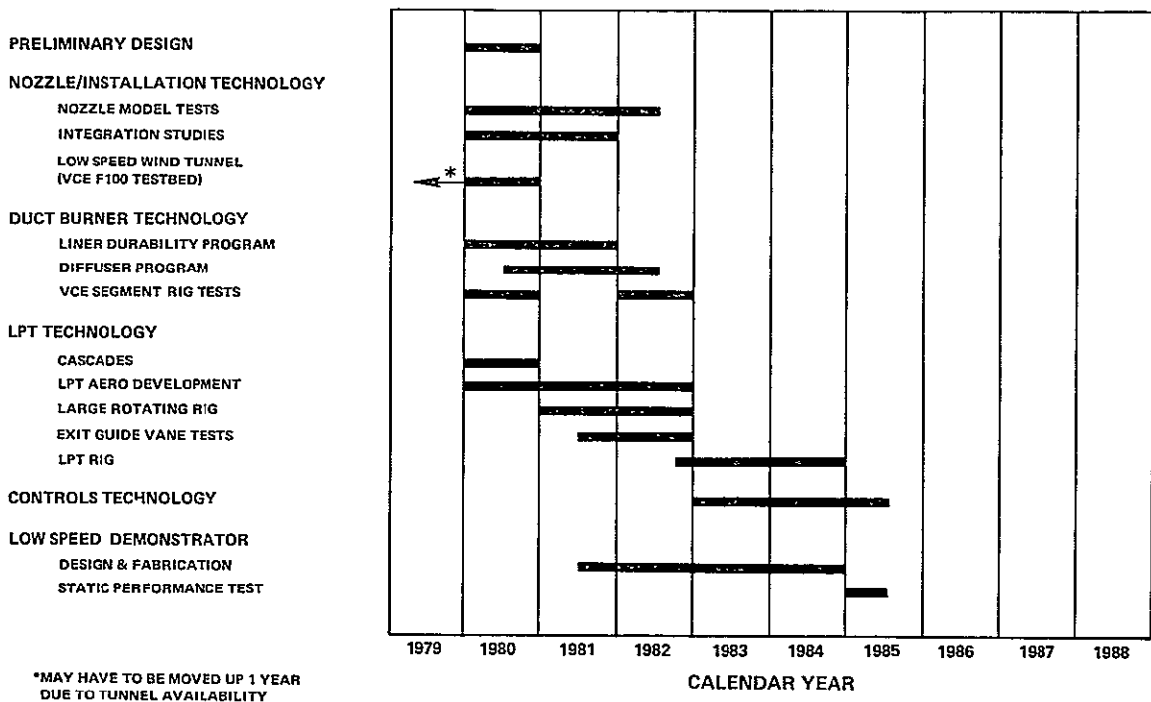

Figure 4.4-13 Reduced Cost Demonstrator Program (E.2) Schedule - The ATEGG core and APSI fan are integrated in this test vehicle to demonstrate the VSCE cycle and duct burner/nozzle technologies. (Cost: 65M in 1979 dollars or 84 in then year dollars)

Flight testing a new engine introduces certain safety considerations outside the norm for conventional ground testing. The element of safety is further amplified when considering the severe engine operating environment imposed by supersonic flight.

Basically, there are two different approaches for a flight program, each with many options available. The least expensive and possibly most effective is the use of an engine as a supplementary power plant in a separate pod of an aircraft. As a second approach, the engine or engines can be used as the sole power source, in which case a complete engine certification would be required. With either approach, the engines would be an all new configuration or based on an existing technology core such as the F100 or ATEGG. The flight program could be conducted initially at subsonic conditions with an existing airframe, then subsequently installing the engine into a supersonic aircraft for evaluation at high Mach number conditions.

With this approach the engine/airframe integration effects could be initially evaluated. It might even be possible to accomplish a fly by to attain flight noise effects. Supersonic flight effects could also be assessed, but are not necessary at first since subsonic flight. Could be studied using a number of existing airframe.

The cost of establishing an engine with some durability would be in the order of \$25 million in 1979 dollars. This cost is, of course, dependent on whether an all new engine is involved or if an existing core is employed. From a cost standpoint, it would be more propitious to start with an existing core, either the F100 or

ATEGG, and install the engine as a supplementary powerplant in a subsonic vehicle. After subsonic performance has been characterized and overall confidence in engine reliability and durability achieved, testing would be directed towards flight testing the engines in a supersonic vehicle.

Using a manned aircraft as the test vehicle dictates the requirement for extensive reliability testing prior to undertaking the actual flight evaluation, thereby making it compulsory to procure several prototype engines. At least one engine must be subjected to a comprehensive preflight certification test to demonstrate reliability and durability. The remaining engines would be used for the flight test. If more than one engine is used as the primary propulsion unit such as with a new research aircraft additional prototype engines must be procured at increased cost to the program.

The estimated cost of the preflight test effort ranges between 50 and 75 million in 1979 dollars. This estimate includes the procurement cost of the engines to be used in the flight evaluation and the preflight testing, but does not include the actual flight test program. Since program cost as well as risk are highly contingent on the specific demonstrator engines configuration used for the test, the preferred approach is to use a demonstrator that incorporates a proven high spool such as an F100 core. Since this would not be a component technology readiness demonstration per se, a demonstrator engine based on this type of configuration would offer the most suitable and practical approach to acquire installation effects data.

SECTION 5.0

CONCLUDING REMARKS

Market projections show a large potential market for long range transports which could be covered by both subsonic and supersonic transports. It is essential for the United States to develop the technology required for a second-generation supersonic transport in order to protect our dominance of this long range market against the threat of a possible foreign supersonic transport. A substantial effort is, therefore, required to establish technology readiness for an economical and environmentally acceptable VCE propulsion system for second-generation supersonic transports. Verification of the advanced component concepts, specifically the low-noise, high-performance coannular nozzle, the low-emissions, high performance duct burner and main engine high temperature components (combustor and turbine), is the first step. Extensive experimental core and engine testing of the various component technologies is a prerequisite to technology readiness, especially to demonstrate the compatibility and interaction of the unique VCE components and to substantiate the operational and durability characteristics of advanced supersonic engine concepts.

In designing the various technology programs, a comprehensive review was made of existing programs as well as those programs projected for the future (i.e., Energy Efficient Engine). Assimilating the VCET effort with those proposed programs ensures a minimum of duplication and a maximum result for the overall effort. Of particular importance at this time is continuing the current VCE Testbed Program and the duct burner and coannular nozzle technology programs since these are unique components for the Pratt & Whitney Aircraft Variable Stream Control Engine. On the other hand, most of the component technology is common for any type of supersonic cruise engine.

Because of the similarity in component technology requirements with the VSCE and IFE concepts, a VCET Program can be instituted at any time to develop their common technologies such as the high temperature technology. Thus, any level of AST engine technology development will be beneficial. An additional consideration is that the technology could be employed for both subsonic commercial transport and military applications.

DISTRIBUTION LIST

NASA-Lewis Research Center
 21000 Brookpark Road
 Cleveland, OH 44135

Attention: Report Control Office	M.S. 5-5	1
Library	M.S. 60-3	2
J. F. McCarthy	M.S. 3-2	1
W. L. Stewart	M.S. 3-5	1
J. E. Dilley	M.S. 500-313	1
F. J. Barina	M.S. 500-211	1
M. A. Beheim	M.S. 86-1	1
D. N. Bowditch	M.S. 86-1	1
D. C. Mikkelson	M.S. 86-1	1
D. E. Harrington	M.S. 86-1	1
R. E. Coltrin	M.S. 86-1	1
R. J. Weber	M.S. 500-307	1
L. H. Fishbach	M.S. 500-307	1
L. C. Franciscus	M.S. 500-307	1
C. L. Zola	M.S. 500-307	1
R. G. Willoh	M.S. 60-5	1
R. E. Jones	M.S. 60-5	1
C. T. Norgren	M.S. 60-5	1
D. A. Petrash	M.S. 60-6	1
M. J. Hartmann	M.S. 5-9	1
C. H. Hauser	M.S. 5-9	1
L. J. Herrig	M.S. 5-9	1
R. Signorelli	M.S. 106-1	1
R. W. Schroeder	M.S. 500-207	1
U. H. von Glahn	M.S. 500-208	1
J. R. Stone	M.S. 500-208	1
F. J. Montegani	M.S. 500-208	1
O. A. Gutierrez	M.S. 500-208	1
A. G. Powers	M.S. 500-307	15
Maj. Alan Willoughby	M.S. 501-3	1
N. T. Musial	M.S. 500-311	1

NASA Scientific and Technical Information Facility
 P. O. Box 8757
 Baltimore, Washington Internation Airport, MD 21240

Attention: Accessioning Department 20

NASA Headquarters
Washington, D.C. 20546

Attention: W. S. Aiken, Jr.	Code RH-5	1
J. A. Suddreth	Code RH-5	1
R. S. Colladay	Code RL-5	1
J. Levine	Code RJ-5	1
P. Renas	Code RL-5	1

NASA-Langley Research Center
Hampton, VA 23665

Attention: V. R. Mascitti	M.S. 249B	1
C. Driver	M.S. 249A	1
S. J. Morris	M.S. 249B	1
S. Hoffman	M.S. 249B	1

NASA-Dryden Flight Research Center
P. O. Box 273
Edwards, CA 93523

Attention: F. W. Burcham	Room 2005	1
J. A. Albers	Room 2089	1

NASA-Ames Research Center
Moffett Field, CA 94035

Attention: L. Roberts	M.S. 200-3	1
-----------------------	------------	---

Naval Air Propulsion Test Center
Trenton, NJ 08628

Attention: A. A. Martino	Code PE4	1
J. J. Curry	Code PE43	1

Air Force Aero Propulsion Lab
Wright Patterson AFB, OH 45433

Attention: E. E. Bailey	AFAPL/TBD	1
E. C. Simpson	AFAPL/TB	1
R. Leo	AFAPL/TBP	1

General Electric Company
Aircraft Engine Group
1000 Western Avenue
Lynn, MA 01910

Attention: J. Vdoviak	A240GA	1
-----------------------	--------	---

General Electric Company
Aircraft Engine Group
1 Jimson Road
Evendale, OH 45215

Attention: R. D. Allan	M.S. E706	1
J. R. Osani	M.S. H4	1
L. C. Wright	M.S. H9	1

The Boeing Commercial Airplane Group
P. O. Box 3999
Seattle, WA 98124

Attention: A. Sigalla		1
G. Evelyn		1
W. C. Swan	Development Center	1
A. D. Welliver	M.S. 41-52	1

Lockheed-California Company
P. O. Box 551
Burbank, CA 91503

Attention: B. Wright	Dept. 75-21, Bldg. 63-3	
	Plant A-1	1
R. L. Foss	Dept. 74-13, Bldg. 243	
	Plant 2	1

Rockwell International Corporation
Aircraft Products Operations
International Airport
Los Angeles, CA 90009

Attention: R. Tyson	Advanced Transports	1
J. Ford	Advanced Transports	1

Rockwell International Corporation
Los Angeles Aircraft Division
Los Angeles, CA 90045

Attention: J. Ross	Code AB71	1
--------------------	-----------	---

Douglas Aircraft Company
3855 Lakewood Boulevard
Long Beach, CA 90801

Attention: R. D. Fitzsimmons	Code 35-74	1
W. Rowe		1

Mr. A. K. Forney
DOT Federal Aviation Administration
Washington, D.C. 20591

1

Mr. Richard Munt
Environmental Protection Agency
2565 Plymouth Road
Ann Arbor, MI 48105

1

1 Report No NASA CR-159539		2 Government Accession No		3 Recipient's Catalog No.	
4 Title and Subtitle VARIABLE CYCLE ENGINE TECHNOLOGY PROGRAM FINAL REPORT FOR THE PLANNING AND DEFINITION STUDY				5 Report Date September 1978	
				6 Performing Organization Code	
7 Author(s) J. S. Westmoreland and A. M. Stern				8. Performing Organization Report No. PWA-5581-12	
9 Performing Organization Name and Address Commercial Products Division Pratt & Whitney Aircraft Group United Technologies Corporation				10 Work Unit No	
				11 Contract or Grant No NAS3-20811	
12 Sponsoring Agency Name and Address National Aeronautics and Space Administration Washington, D.C. 20546				13 Type of Report and Period Covered Contractor Report	
				14. Sponsoring Agency Code	
15 Supplementary Notes Project Manager, Albert G. Powers NASA Lewis Research Center Cleveland, Ohio 44135					
16 Abstract This study was aimed at the overall planning and definition of a Variable Cycle Engine Technology (VCET) Program. The work involved selecting a base VCE engine, identifying critical technologies, defining demonstrator configurations, and formulating program plans. The Variable Stream Control Engine, VSCE-502B, was selected as the base engine, with the Inverted Flow Engine concept selected as a backup. Critical component technologies were identified, and technology programs were formulated. Several engine configurations were defined on a preliminary basis to serve as demonstration vehicles for the various technologies. The different configurations present compromises in cost, technical risk and technology return. Plans for possible VCET Programs were formulated by synthesizing the technology requirements with the different demonstrator configurations.					
17. Key Words (Suggested by Author(s)) Variable Cycle Engine (VCE) Variable Cycle Engine Technology (VCET) Program VSCE-502B Low-Emissions Duct Burner Coannular Exhaust Nozzle Advanced Supersonic Technology (AST)				18 Distribution Statement	
19. Security Classif. (of this report) UNCLASSIFIED		20. Security Classif (of this page) UNCLASSIFIED		21 No. of Pages 83	22 Price*

For sale by the National Technical Information Service, Springfield, Virginia 22161