

NASA Technical Paper 1523

TECH LIBRARY KAFB, NM
0134820
KIRTLAND AFB, N. M.



Effects of Diffusion Factor, Aspect Ratio, and Solidity on Overall Performance of 14 Compressor Middle Stages

Werner R. Britsch, Walter M. Osborn,
and Mark R. Laessig

SEPTEMBER 1979





NASA Technical Paper 1523

Effects of Diffusion Factor,
Aspect Ratio, and Solidity
on Overall Performance of
14 Compressor Middle Stages

Werner R. Britsch, Walter M. Osborn,
and Mark R. Laessig
*Lewis Research Center
Cleveland, Ohio*



National Aeronautics
and Space Administration

**Scientific and Technical
Information Branch**

1979

SUMMARY

The effects of diffusion factor, aspect ratio, and solidity on rotor and stage performance have been evaluated for 14 subsonic compressor middle stages with a hub-tip ratio of 0.8 and a design tip speed of 243.8 meters per second. Peak rotor efficiencies ranged from 0.898 to 0.944. Peak stage efficiencies ranged from 0.850 to 0.902, and stage stall margins were generally above 15 percent. Both the efficiency and mass flow rate of the rotors and stages generally decreased with increases in solidity from 0.9 to 2.0 at all blade loadings tested. The rotor and stage efficiencies of moderately loaded stages generally increased as the rotor aspect ratio was reduced from 1.2 to 0.7. The efficiencies of lightly loaded stages decreased slightly as the rotor aspect ratio was reduced from 1.0 to 0.67.

INTRODUCTION

The NASA Lewis Research Center is engaged in a research program on axial-flow compressors for advanced airbreathing engines. This program is directed primarily toward providing the technology for smaller and lighter compressors with higher performance levels.

In support of this program, experimental studies are being conducted on a series of high-hub-tip-radius-ratio compressor stages representative of the middle and latter stages of axial-flow compressors. In these studies, the effects of aspect ratio, diffusion factor, and solidity on rotor and stage performance are being determined. As part of this program, 14 middle stages were tested to assess the effects on performance of varying both diffusion through the rotor and stator blades and blade aspect ratio. The compressor stages were each operated as a single stage without a preceding blade row, and no attempt was made to simulate the effects of a multistage environment. Both the tip diameter and the hub-tip radius ratio were held constant throughout each stage at 50.8 centimeters and 0.8, respectively. The design tip speed was 243.8 meters per second.

This report presents the overall performance obtained for the 14 compressor middle stages and evaluates some effects of the variations in diffusion, aspect ratio, and solidity that were incorporated into the configurations tested. The data are presented over the stable operating range of each stage from 50 to 120 percent of design speed.

The symbols are defined in appendix A. The equations are presented in appendix B. The terms and units used in the tables are defined in appendix C.

AERODYNAMIC DESIGN

Three computer programs were used in designing these stages: a streamline analysis program, a blade geometry program, and a blade coordinate program. The overall blade design method is outlined in reference 1. The blade coordinate program is presented in reference 2. The design system is described briefly in this report.

The streamline analysis program was used to calculate the flow-field parameters at several axial locations, including planes approximating the blade leading and trailing edges for both the rotor and stator. The mass flow, rotative speed, flow-path geometry, and radial distributions of total pressure and total temperature are inputs to this program. The program accounts for both streamline curvature and entropy gradients. Boundary-layer blockage factors are also included.

The distributions of total pressure and total temperature and the resulting velocity distributions calculated in the streamline analysis program were used in the blade geometry program to define the blade geometry parameters. The blade geometry parameters were then used in the blade coordinate program (ref. 2) to compute blade elements on conical surfaces through the blade row. In this program the blade elements are stacked on a line passing through their centroids and then the blade section coordinates, which are used directly in fabrication, are computed.

These programs were used to design six of the 14 compressor middle stages with a mass flow of 9.46 kilograms per second and a tip speed of 243.8 meters per second. The six designs were selected to provide data on how aspect ratio and diffusion factor affect the performance of compressor middle stages. Although the diffusion factor was not an input to the streamline analysis program, the level of this parameter was controlled through the stage pressure ratio. Double-circular-arc blade profiles were used for all the blades in this series of compressors.

The characteristics of the six resulting design stages, along with those of the eight derived stages, are given in table 1 and figure 1. Stages 23B-20, 24A-20, and 25A-20B were designed for low blade loading and produced diffusion factors from 0.40 to 0.44 in both the rotors and stators. The diffusion factors were obtained from experimental blade-element data, taken at design speed, and from several mass flows, by mass averaging from hub to tip. These mass-averaged values yielded the single value quoted herein by interpolation along the design speed line to correspond to the maximum-efficiency operating point. Stages 26B-21 and 27A-21 were designed for intermediate blade loading and produced diffusion factors of 0.49 and 0.52 in the rotors

and 0.52 and 0.50 in the stators, respectively. Stage 28B-22 was designed for high blade loading and produced a diffusion factor of 0.58 in both the rotor and stator.

The remaining eight configurations were derived by either adding or removing blades to change the solidity without changing the blade aspect ratio. This process is represented in figure 2. Blades were added in both the rotor and stator of stages 23D-20C and 24B-20C to increase stator solidity. Stator blades were removed from stator 20 to produce stator 20B, used in stage 25A-20B. Rotor blades were removed from stage 27A-21 to create stages 27C-21 and 27D-21, and both rotor and stator blades were removed from stage 27A-21 to create stage 27D-21D. Removing blades lowered solidity and provided an opportunity to assess stage performance when stators of different solidities were matched to a given rotor. Similar variations in the number of blades, using 26B-21 as a parent stage, produced stages 26D-21 and 26D-21D. Finally, rotor blades were removed in stage 28B-22 to create stage 28D-22.

Since these eight derived stages had no true design point, all 14 configurations were compared at maximum-efficiency operation at 243.8 meters per second tip speed. In 10 of the 14 configurations, rotor and stator solidities were approximately equal, varying from 0.9 to 2.0. (Throughout this report, solidity is defined at the tip radius.) In stages 27C-21 and 28D-22, a rotor having a solidity of 1.35 was matched with a stator having a solidity of 1.8. In stages 26D-21 and 27D-21, the rotor solidity was 0.9 and the stator solidity was 1.8. The rotor aspect ratios in the configurations tested varied from 0.67 in stages 24A-20 and 24B-20C to 2.0 in stage 25A-20B. Stator aspect ratios ranged from 0.82 in stages 28B-22 and 28D-22 to 1.24 in all stages 26 and 27.

Since the flow through the stages was subsonic, a straight hub and outer casing were used in all 14 configurations to allow easier fabrication and testing. The flow-path geometry was the same for all 14 stages and is shown in figures 3 to 8. The only variation among these figures is the location of the blade leading and trailing edges and instrumentation locations to accommodate the variation in aspect ratio.

The velocity diagrams for the six design stages were calculated at several axial locations, including the leading edges of the rotor and stator blades, by using the streamline analysis program. The rotors were designed to provide a uniform pressure distribution at the rotor discharge. Design values of the overall performance and blade-element parameters are presented in tables 2 to 7 for each of the six design rotor and stator combinations. The resulting geometry of the double-circular-arc blades is presented in tables 8 to 13 for the six design rotors and in tables 14 to 17 for the three design stators selected. Design parameters are provided for four stator configurations. Although the two stators designated as 20 and 20B differed only in the number of blades, design calculations were conducted for both configurations.

APPARATUS AND PROCEDURE

Compressor Test Facility

These stages were all tested in the single-stage compressor test facility described in reference 1 and shown schematically in figure 9. Atmospheric air enters the test facility through an inlet on the building roof and passes through the flow-measuring orifice and into the plenum chamber upstream of the test stage. The air then passes through the experimental compressor stage into the collector and is exhausted to the atmosphere.

Instrumentation

The compressor mass flow was determined from measurements on a calibrated thin-plate orifice. The orifice air temperature was determined from an average of two Chromel-constantan readings. Radial surveys of the flow conditions were made upstream of the rotor, between the rotor and stator, and downstream of the stator (see figs. 3 to 8 for axial location). The survey probes are shown in figure 10. Total pressure, total temperature, and flow angle were measured with the combination cobra probe (fig. 10(a)) and static pressure was measured with an 18° wedge probe (fig. 10(b)). Each probe was automatically aligned to the flow direction by a null-balancing control system sensitive to the flow direction. The thermocouple material was Chromel-constantan. Two combination wedge probes and two static wedge probes were used at each of the three measuring stations.

At stations 1 and 4, rakes were used to obtain total pressure and total temperature so that boundary-layer thickness and stage performance could be monitored during testing. Data from these probes are not presented herein. In addition, inner and outer wall static-pressure taps were located at approximately the same axial stations as the survey probes. The circumferential locations of the instrumentation used are shown in figures 11 and 12. An electronic speed counter was used in conjunction with a magnetic pickup to measure rotative speed (rpm).

The estimated errors of the data based on inherent inaccuracies of the instrumentation and recording system are as follows:

Flow rate, kg/sec	±0.3
Rotative speed, rpm	±30
Flow angle, deg	±1
Temperature, K	±0.6
Rotor-inlet total pressure, N/cm ²	±0.01

Rotor-outlet total pressure, N/cm ²	±0.10
Stator-outlet total pressure, N/cm ²	±0.10
Rotor-inlet static pressure, N/cm ²	±0.04
Rotor-outlet static pressure, N/cm ²	±0.07
Stator-outlet static pressure, N/cm ²	±0.07

Test Stages

The characteristics of the 12 rotors and seven stators that in various combinations represent the 14 stages tested are summarized in table 1. The 12 rotor configurations are shown in figures 13 to 24, and the six stator configurations in figures 25 to 30. A single casing was used for all the stages. Spacers were used in the casing and in the hub to obtain the relative locations of the rotors, stators, and instrumentation. The stator blades were supported by the inner and outer retaining rings shown in figures 25 to 30. The blades were inserted into contoured slots in that part of the ring comprising the flow-passage wall and secured. The assembly was held in place by the casing and the spacers. The nonrotating rotor-tip clearance for each configuration is shown in table 18.

Test Procedure

Stage survey data were recorded over a mass-flow range from maximum-flow to near-stall conditions at 70, 90, 100, 110, and 120 percent of design speed. At 50, 60, and 80 percent of design speed, data were recorded at near-stall conditions only. For each test operating point, data were recorded at nine radial positions.

At each radial position the two combination probes behind the stator (station 3) were circumferentially traversed to nine locations across the stator gap. The wedge probes were set at midgap because studies on previous stages had shown that the static pressure across the stator gap was constant. Total pressure, total temperature, and flow angle were recorded at each circumferential position. At the last circumferential position, pressure, temperature, and flow angle were also recorded at stations 1 and 2. All probes were then traversed to the next radial position, and the circumferential traverse procedure was repeated.

Calculation Procedure

Measured total temperatures and total pressures were corrected for Mach number and design streamline slope. These corrections were based on instrument probe cali-

brations given in reference 3. The stream static pressure was corrected for Mach number and streamline slope based on an average calibration for the type of probe used.

The static pressure at each radial position downstream of the stator was assumed to be uniform across the blade passage and equal to the midgap value. At each radial position, averaged values of the nine circumferential measurements of total pressure, total temperature, and flow angle downstream of the stator were obtained in the following manner: The midgap static pressure was used with the local total pressure, total temperature, and flow angle to calculate the circumferential distributions of velocity, static density, and axial and tangential velocity components. These distributions were then used in the circumferential mass-averaging process. The nine values of total temperature were mass averaged to obtain the circumferentially averaged stator-outlet total temperature. The nine local values of total pressure were ratioed to the rotor-inlet total pressure and converted to equivalent isentropic temperature ratios. These ratios were then mass averaged, and the resulting value was converted (through the isentropic temperature-pressure ratio relations) to a mass-averaged total-pressure ratio. The average absolute velocity was obtained from the midgap static pressure, the average total pressure, and the average total temperature. The average tangential velocity was mass averaged by using the local static density and the axial and tangential velocity components. The average absolute velocity and tangential velocity components were used to calculate the average flow angle and the average axial velocity. This calculation was performed for both sets of probes at the stator discharge, and the results from each set of probes were averaged to obtain single average values of total pressure, total temperature, static pressure, and flow angle at each radial position. To obtain the overall performance, the radial distributions of total temperature and total pressure were averaged by a procedure that is similar to that used for averaging the circumferential distributions of these parameters. At each measuring station, the integrated mass flow was computed from the radial survey data.

The mass flow at stall was obtained in the following manner: During operation at the near-stall condition, the collector valve (fig. 3) was slowly closed in small increments. At each increment the mass flow was obtained. The mass flow obtained just before stall is called the stall mass flow. The pressure ratio at stall was obtained by extrapolating the total pressure obtained from the survey data to the stall mass flow.

Orifice mass flows, total pressures, static pressures, and total temperatures were all corrected to standard-day conditions based on the rotor-inlet conditions.

RESULTS AND DISCUSSION

The results drawn from the data obtained in this investigation are presented in two main sections. The overall performance is described, for both the rotor and the stage, for the 14 configurations tested. The effects of varying solidity, diffusion factor, and aspect ratio on performance are assessed, and their combined effect on performance is determined.

Overall Performance

The overall performance of the 14 stages tested is presented in figures 31 to 44, the performance of the 12 rotors, with each rotor functioning as an integral part of the stage, is shown in figures 45 to 58. Pressure ratio, temperature ratio, and efficiency are presented at several mass flows from choke to near stall at 70, 90, 100, 110, and 120 percent of design speed and at near stall at 50, 60, and 80 percent of design speed. The actual stage stall line is shown in figures 31 to 44 as a dashed line. The effects of solidity and aspect ratio are shown in figures 59 to 69. The effect of solidity, aspect ratio, and diffusion factor on rotor performance is presented in figure 70. All these comparisons are made for the 100-percent-speed lines. The plotted data are presented in tabular form in tables 19 to 32.

The highest rotor efficiency (0.944) was obtained with rotor 26D in stage 26D-21, which had a diffusion factor at maximum-efficiency operation of 0.51, an aspect ratio of 1.2, and a solidity of 0.9. The highest stage efficiency (0.902) was obtained with stage 27A-21, which had diffusion factors at maximum-efficiency operation of 0.52 in the rotor and 0.50 in the stator, a rotor aspect ratio of 0.7, a stator aspect ratio of 1.24, and a tip solidity of 1.8 in both the rotor and stator.

Effects of Solidity and Aspect Ratio

Solidity. - The effects of solidity on the performance of the rotors and stages at design speed are presented in figures 59 to 63. At constant blade aspect ratio, rotors with more blades, and thus higher solidities, had lower mass flows than rotors with fewer blades and lower solidities. This reduction in flow is most likely caused by the greater blade blockage for the higher solidities.

Low-solidity rotors had significantly higher maximum efficiencies at design speed than high-solidity rotors at all diffusion factors tested (figs. 59 to 61), and these maximums occurred at higher mass flows. For example, at low blade loading (fig. 59), rotor 23B, with a solidity of 1.6, attained a peak efficiency of 0.916 at a mass flow of

9.4 kilograms per second; and rotor 23D, with a solidity of 2.0, attained 0.903 at 8.1 kilograms per second. At high blade loading (fig. 60), rotor 28D, with a solidity of 1.36, attained a peak efficiency of 0.938 at a mass flow of 11.1 kilograms per second; and rotor 28B, with a solidity of 1.8, attained 0.929 at 9.9 kilograms per second. Reducing solidity also tended to increase the stall margin at all diffusion factors tested (table 1).

The effect of solidity on stage performance is shown in figures 62 and 63 for stages 26 and 27. Figure 62 illustrates that the difference in maximum stage efficiency between stages 26D-21D and 26D-21 can be attributed to mismatching between the rotor and stator, resulting from the change in stator solidity from 1.8 to 0.9. Although the rotor efficiencies for the two stages were virtually identical throughout the range of mass flows tested, the stage efficiency was lower for 26D-21, especially at the higher mass flows. Mismatching is evident from the graph of efficiency difference across the stator as a function of mass flow. For stage 26D-21D, the maximum rotor efficiency and the minimum stator-efficiency difference occurred at almost the same mass flow; but for stage 26D-21, the minimum stator-efficiency difference occurred near stall flow and the maximum rotor-efficiency difference occurred in the middle of the flow range. The same trends are evident for the stage 27 rotors (fig. 63).

No significant change in the minimum-efficiency difference occurred when stator solidity was lowered. Therefore, stator designs with fewer blades, and hence lower solidity, would mean lower fabrication cost without sacrificing performance.

Aspect ratio. - The effects of aspect ratio on the performance of the rotors and stages were assessed at low and intermediate blade loadings and are presented graphically in figures 64 to 69. At low blade loading, with diffusion factors of 0.45 or lower, decreasing the aspect ratio from 1.0 to 0.67 resulted in a slight reduction in peak rotor efficiency with solidity held constant at both 1.6 and 2.0 (fig. 64). The slightly greater flow range for the lower-aspect-ratio stages at design speed is not considered to be significant, since the high flow points may not have been obtained at maximum capacity.

At diffusion factors of about 0.50, reductions in aspect ratio from 1.2 to 0.7 were evaluated with rotors 26B and 27A with solidity constant at 1.8 (fig. 65) and with rotors 26D and 27D with solidity constant at 0.9 (fig. 66). Rotor 27A, which had an aspect ratio of 0.7, had an efficiency about 1.5 points higher than rotor 26B, which had an aspect ratio of 1.2. The mass-flow range of rotor 27A (2.6 kg/sec) was larger than that of rotor 26B (2.0 kg/sec) by about 20 percent. The pressure ratio of rotor 27A was greater than that of rotor 26B throughout the flow range.

A similar comparison is shown for rotors 26D and 27D, which differ from their parent rotors 26B and 27A in blade number only (fig. 2). At this lower solidity (0.9)

and lower overall pressure ratio, no significant efficiency trend was observed as aspect ratio was reduced from 1.2 to 0.7. However, the pressure ratio over most of the flow range was somewhat higher for the lower-aspect-ratio rotor.

Comparing stage performance shows trends generally similar to those observed for the rotors (figs. 67 to 69). At low blade loadings and a solidity of 1.6, the stage efficiencies were slightly higher at a rotor aspect ratio of 1.0 than at a rotor aspect ratio of 0.67. At a solidity of 2.0, the stage efficiencies were almost the same (fig. 67). At moderate blade loadings (diffusion factors of about 0.5), the stage efficiencies became higher as the rotor aspect ratio was decreased from 1.2 to 0.7, regardless of the solidity (figs. 68 and 69).

The maximum efficiencies of all the rotors tested are compared as a function of aspect ratio in figure 70; the effects of solidity and diffusion factor are also indicated. At low blade loadings, decreasing the aspect ratio from 1.0 to 0.67 resulted in a small reduction in efficiency, but decreasing the solidity from 2.0 to 1.6 had a greater effect, increasing efficiency by about 1 percentage point. The efficiency of rotor 25A, with an aspect ratio of 2.0 and a solidity of 1.2, is comparable to those measured for the remaining rotors tested at low blade loadings. However, since rotors with lower aspect ratios and this diffusion factor have not been tested at such a low solidity, a comparison cannot be made.

The efficiency of rotors 26B and 27A, with diffusion factors of 0.49 and 0.52, respectively, and solidities of 1.8, increased by about 1.5 percentage points as the aspect ratio was decreased from 1.2 to 0.7. However, rotors 26D and 27D, with diffusion factors of 0.49 to 0.53 and solidities of 0.9, showed no conclusive efficiency trend as the aspect ratio was decreased.

SUMMARY OF RESULTS

A comparison of the overall performance data obtained for 14 compressor middle stages is presented. These stages had a tip speed of 243.8 meters per second and a hub-tip radius ratio of 0.8. The parameters varied were aspect ratio, diffusion factor, and solidity. The principal results of these tests were as follows:

1. The highest rotor efficiency (0.944) was obtained with rotor 26D in stage 26D-21, which had a diffusion factor at maximum-efficiency operation of 0.51, an aspect ratio of 1.2, and a solidity of 0.9. The highest stage efficiency (0.902) was obtained with stage 27A-21, which had a diffusion factor at maximum-efficiency operation of 0.52 in the rotor and 0.50 in the stator, a rotor aspect ratio of 0.7, a stator aspect ratio of 1.24, and solidities of 1.8 in both rotor and stator.

2. Reducing rotor solidity, at constant rotor aspect ratio and stator solidity, by using fewer rotor blades generally resulted in a shift to higher mass flows, an increase in the stall margin, and a significant increase in the maximum rotor and stage efficiencies.

3. Reducing rotor aspect ratio at constant rotor solidity and stator aspect ratio had the following effects:

a. At diffusion factors of about 0.45, the efficiencies and pressure ratios of both rotors and stages decreased slightly when the rotor aspect ratio was reduced from 1.0 to 0.67.

b. At diffusion factors of about 0.50, the maximum rotor and stage efficiencies increased when the rotor aspect ratio was reduced from 1.2 to 0.7 at solidities of 1.8. At a rotor solidity of 0.9, there was no significant change in rotor efficiency when the rotor aspect ratio was decreased.

Lewis Research Center,

National Aeronautics and Space Administration,

Cleveland, Ohio, May 2, 1979,

505-04.

APPENDIX A

SYMBOLS

AR	blade aspect ratio, defined as ratio of blade height over mean chord length
A_{an}	annulus area at rotor leading edge, m^2
A_f	frontal area at rotor leading edge, m^2
C_p	specific heat at constant pressure, $1004 J/(kg)(K)$
D	diffusion factor
i_{mc}	mean incidence angle, angle between inlet air direction and line tangent to blade mean camber line at leading edge, deg
i_{ss}	suction-surface incidence angle, angle between inlet air direction and line tangent to blade suction surface at leading edge, deg
N	rotative speed, rpm
P	total pressure, N/cm^2
p	static pressure, N/cm^2
r	radius, cm
SM	stall margin
U	wheel speed, m/sec
V	air velocity, m/sec
W	weight flow, kg/sec
α_c	cone angle, deg
α_s	slope of streamline, deg
β	air angle, angle between air velocity and axial direction, deg
β'_c	relative meridional air angle based on cone angle, $\arctan(\tan \beta'_m \cos \alpha_c / \cos \alpha_s)$, deg
γ	ratio of specific heats (1.40)
δ	ratio of rotor-inlet total pressure to standard pressure of $10.13 N/cm^2$
δ^o	deviation angle, angle between exit air direction and tangent to blade mean camber line at trailing edge, deg
η	efficiency

θ	ratio of rotor-inlet total temperature to standard temperature of 288.2 K
κ_{mc}	angle between blade mean camber line and meridional plane, deg
κ_{ss}	angle between blade suction-surface camber line at leading edge and meridional plane, deg
σ	solidity, ratio of chord to spacing, at maximum radius
$\bar{\omega}$	total-loss coefficient
$\bar{\omega}_p$	profile-loss coefficient
$\bar{\omega}_s$	shock-loss coefficient

Subscripts:

ad	adiabatic (temperature rise)
id	ideal
LE	blade leading edge
m	meridional direction
mom	momentum rise
p	polytropic
R	rotor
r	radial direction
ref	reference
S	stator
TE	blade trailing edge
z	axial direction
θ	tangential direction
1	instrumentation plane upstream of rotor
2	instrumentation plane between rotor and stator
3	instrumentation plane downstream of stator

Superscript:

'	relative to blade
---	-------------------

APPENDIX B

EQUATIONS

Suction-surface incidence angle:

$$i_{ss} = \left(\beta'_c\right)_{LE} - \kappa_{ss} \quad (B1)$$

Mean incidence angle:

$$i_{mc} = \left(\beta'_c\right)_{LE} - \left(\kappa_{mc}\right)_{LE} \quad (B2)$$

Deviation angle:

$$\delta^o = \left(\beta'_c\right)_{TE} - \left(\kappa_{mc}\right)_{TE} \quad (B3)$$

Diffusion factor:

$$D = 1 - \frac{V'_{TE}}{V'_{LE}} + \left| \frac{\left(rV_\theta\right)_{TE} - \left(rV_\theta\right)_{LE}}{\left(r_{TE} + r_{LE}\right)\sigma\left(V'_{LE}\right)} \right| \quad (B4)$$

Total-loss coefficient:

$$\bar{\omega} = \frac{\left(P'_{id}\right)_{TE} - P'_{TE}}{P'_{LE} - P_{LE}} \quad (B5)$$

Profile-loss coefficient:

$$\bar{\omega}_p = \bar{\omega} - \bar{\omega}_s \quad (B6)$$

Total-loss parameter:

$$\frac{\bar{\omega} \cos\left(\beta'_m\right)_{TE}}{2\sigma} \quad (B7)$$

Profile-loss parameter:

$$\frac{\bar{\omega}_p \cos(\beta'_m)_{TE}}{2\sigma} \quad (B8)$$

Adiabatic (temperature rise) efficiency:

$$\eta_{ad} = \frac{\left(\frac{P_{TE}}{P_{LE}}\right)^{(\gamma-1)/\gamma} - 1}{\frac{T_{TE}}{T_{LE}} - 1} \quad (B9)$$

Momentum-rise efficiency:

$$\eta_{mom} = \frac{\left(\frac{P_{TE}}{P_{LE}}\right)^{(\gamma-1)/\gamma} - 1}{\frac{(UV_\theta)_{TE} - (UV_\theta)_{LE}}{T_{LE} C_p}} \quad (B10)$$

Equivalent weight flow:

$$\frac{W\sqrt{\theta}}{\delta} \quad (B11)$$

Equivalent rotative speed:

$$\frac{N}{\sqrt{\theta}} \quad (B12)$$

Weight flow per unit annulus area:

$$\frac{\frac{W\sqrt{\theta}}{\delta}}{A_{an}} \quad (B13)$$

Weight flow per unit frontal area:

$$\frac{\frac{W\sqrt{\theta}}{\delta}}{A_f} \quad (\text{B14})$$

Head-rise coefficient:

$$\frac{C_p T_{LE}}{U_{tip}^2} \left[\left(\frac{P_{TE}}{P_{LE}} \right)^{(\gamma-1)/\gamma} - 1 \right] \quad (\text{B15})$$

Flow coefficient:

$$\left(\frac{V_z}{U_{tip}} \right)_{LE} \quad (\text{B16})$$

Stall margin:

$$SM = \left[\frac{\left(\frac{P_{TE}}{P_{LE}} \right)_{stall}}{\left(\frac{P_{TE}}{P_{LE}} \right)_{ref}} \times \frac{\left(\frac{W\sqrt{\theta}}{\delta} \right)_{ref}}{\left(\frac{W\sqrt{\theta}}{\delta} \right)_{stall}} - 1 \right] \times 100 \quad (\text{B17})$$

Polytropic efficiency:

$$\eta_p = \frac{\ln \left(\frac{P_{TE}}{P_{LE}} \right)^{(\gamma-1)/\gamma}}{\ln \left(\frac{T_{TE}}{T_{LE}} \right)} \quad (\text{B18})$$

APPENDIX C

TERMS AND UNITS USED IN TABLES

ABS	absolute
AERO CHORD	straight line between blade leading and trailing edges along design streamline, cm
AREA RATIO	ratio of actual flow area to critical area (where local Mach number is 1)
BETAM	meridional air angle, deg
CONE ANGLE	angle between axial direction and conical surface representing blade element, deg
DELTA INC	mean incidence minus suction-surface incidence angles, deg
DEV	deviation angle (defined by eq. (B3)), deg
D-FACT	diffusion factor (defined by eq. (B4))
EFF	adiabatic efficiency (defined by eq. (B9))
IN	inlet (leading edge of blade)
INCIDENCE	incidence angle (mean defined by eq. (B2)), deg
KIC	angle between blade mean camber line at leading edge and meridional plane, deg
KOC	angle between blade mean camber line at trailing edge and meridional plane, deg
KTC	angle between blade mean camber line at transition point and meridional plane, deg
LOSS COEFF	loss coefficient (total defined by eq. (B5) and profile defined by eq. (B6))
LOSS PARAM	loss parameter (total defined by eq. (B7) and profile defined by eq. (B8))
MERID	meridional
MERID VEL R	meridional velocity ratio
OUT	outlet (trailing edge of blade)
PERCENT SPAN	percent of blade span from tip at rotor outlet

PHISS	suction-surface camber ahead of assumed shock location, deg
PRESS	pressure, N/cm^2
PROF	profile
RADII	radius, cm
REL	relative to blade
RI	inlet radius (leading edge of blade), cm
RO	outlet radius (trailing edge of blade), cm
RP	radial position
RPM	equivalent rotative speed, rpm
SETTING ANGLE	angle between aerodynamic chord and meridional plane, deg
SOLIDITY	ratio of aerodynamic chord to blade spacing
STREAMLINE SLOPE	slope of streamline, deg
TANG	tangential
TEMP	temperature, K
TI	blade thickness at leading edge, cm
TM	maximum blade thickness, cm
TO	blade thickness at trailing edge, cm
TOT	total
TOTAL CAMBER	difference between inlet and outlet blade mean camber lines, deg
VEL	velocity, m/sec
WHEEL SPEED	blade wheel speed, m/sec
WT FLOW	equivalent weight flow, kg/sec
X FACTOR	ratio of suction-surface camber ahead of assumed shock loca- tion of a multiple-circular-arc blade section to that of a double-circular-arc blade section
ZIC	axial distance to blade leading edge from inlet, cm
ZMC	axial distance to blade maximum-thickness point from inlet, cm
ZOC	axial distance to blade trailing edge from inlet, cm
ZTC	axial distance to transition point from inlet, cm

REFERENCES

1. Urasek, Donald C. ; and Janetzke, David C. : Overall and Blade Element Performance of Tandem-Bladed Transonic Compressor Rotor with Tip Speed of 1375 Feet Per Second. NASA TM X-2484, 1972.
2. Crouse, James E. ; Janetzke, David C. ; and Schwirian, Richard E. : A Computer Program for Composing Compressor Blading from Simulated Circular-Arc Elements on Conical Surfaces. NASA TN D-5437, 1969.
3. Glawe, George E. ; and Krause, Lloyd N. : Miniature Probes for Use in Gas Turbine Testing. NASA TM X-71638, 1974.

TABLE 1. - COMPRESSOR TEST STAGES

Blade loading	Stage	Rotor						Stator						Stage stall margin, percent
		Number	Blade chord, cm	Number of blades	Diffusion factor	Aspect ratio	Solidity	Number	Blade chord, cm	Number of blades	Diffusion factor	Aspect ratio	Solidity	
Low	23B-20 ^a	23B	5.08	50	0.44	1.00	1.6	20	4.89	52	0.44	1.04	1.6	22
	23D-20C	23D	5.08	63	.44	1.00	2.0	20C	↓	66	.46	↓	2.0	20
	24A-20 ^a	24A	7.62	34	.43	.67	1.6	20	↓	52	.44	↓	1.6	22
	24B-20C	24B	7.62	43	.45	.67	2.0	20C	↓	66	.46	↓	2.0	19
	25A-20B ^a	25A	2.54	77	.43	2.00	1.2	20B	↓	40	.42	↓	1.2	15
Inter-mediate	26B-21 ^a	26B	4.24	68	0.49	1.20	1.8	21	4.09	70	0.46	1.24	1.8	13
	26D-21	26D	4.24	34	.51	1.20	.9	21	↓	70	.42	↓	1.8	21
	26D-21D	26D	4.24	34	.49	1.20	.9	21D	↓	35	.49	↓	.9	19
	27A-21 ^a	27A	7.19	40	.51	.70	1.8	21	↓	70	.48	↓	1.8	18
	27C-21	27C	↓	30	.51	↓	1.35	21	↓	70	.48	↓	1.8	21
	27D-21	27D	↓	20	.53	↓	.9	21	↓	70	.43	↓	1.8	15
	27D-21D	27D	↓	20	.50	↓	.9	21D	↓	35	.50	↓	.9	22
High	28B-22 ^a	29B	6.35	45	0.56	0.80	1.8	22	6.22	46	0.56	0.82	1.8	13
	28D-22	28D	6.35	34	.56	.80	1.36	22	6.22	46	.55	.82	1.8	17

^aOriginal design.

TABLE 2. - DESIGN PARAMETERS

FOR STAGE 23B-20

(a) Overall parameters for stage 23B-20

ROTOR TOTAL PRESSURE RATIO.....	1.257
STAGE TOTAL PRESSURE RATIO.....	1.252
ROTOR TOTAL TEMPERATURE RATIO.....	1.072
STAGE TOTAL TEMPERATURE RATIO.....	1.072
ROTOR ADIABATIC EFFICIENCY.....	0.940
STAGE ADIABATIC EFFICIENCY.....	0.921
ROTOR POLYTROPIC EFFICIENCY.....	0.942
STAGE POLYTROPIC EFFICIENCY.....	0.924
ROTOR HEAD RISE COEFFICIENT.....	0.329
STAGE HEAD RISE COEFFICIENT.....	0.322
FLOW COEFFICIENT.....	0.470
WT FLOW PER UNIT FRONTAL AREA.....	46.661
WT FLOW PER UNIT ANNULUS AREA.....	129.614
WT FLOW.....	9.457
RPM.....	9170.000
TIP SPEED.....	243.911

TABLE 2. - Continued.

(b) Blade-element parameters for rotor 23B

RP	RADII		ABS BETAM		REL BETAM		TOTAL TEMP		TOTAL PRESS	
	IN	OUT	IN	OUT	IN	OUT	IN	RATIO	IN	RATIO
TIP	25.400	25.400	0.	45.0	64.8	58.0	288.2	1.079	10.13	1.257
1	25.168	25.146	-0.	43.2	64.6	57.3	288.2	1.076	10.13	1.257
2	24.912	24.892	-0.	41.8	64.4	56.6	288.2	1.073	10.13	1.257
3	24.656	24.638	0.	41.2	64.2	55.9	288.2	1.072	10.13	1.257
4	23.886	23.876	0.	41.3	63.5	53.8	288.2	1.071	10.13	1.257
5	22.856	22.860	0.	42.3	62.4	50.9	288.2	1.071	10.13	1.257
6	21.829	21.844	0.	43.7	61.4	47.6	288.2	1.071	10.13	1.257
7	21.055	21.082	0.	45.7	60.5	44.7	288.2	1.072	10.13	1.257
8	20.797	20.828	0.	46.8	60.2	43.6	288.2	1.073	10.13	1.257
9	20.538	20.574	0.	48.3	59.9	42.3	288.2	1.075	10.13	1.257
HUB	20.320	20.320	-0.	50.0	59.6	40.8	288.2	1.076	10.13	1.257

RP	ABS VEL		REL VEL		MERID VEL		TANG VEL		WHEEL SPEED	
	IN	OUT	IN	OUT	IN	OUT	IN	OUT	IN	OUT
TIP	114.6	132.6	269.5	177.0	114.6	93.7	0.	93.8	243.9	243.9
1	114.6	132.6	267.5	179.1	114.6	96.7	-0.	90.7	241.7	241.5
2	114.6	133.0	265.3	180.1	114.6	99.1	-0.	88.7	239.2	239.0
3	114.6	133.7	263.0	179.5	114.6	100.7	0.	88.0	236.8	236.6
4	114.6	135.9	256.4	172.9	114.6	102.1	0.	89.7	229.4	229.3
5	114.5	138.7	247.6	162.5	114.5	102.5	0.	93.4	219.5	219.5
6	114.5	141.5	238.9	151.7	114.5	102.3	0.	97.8	209.6	209.8
7	114.4	143.8	232.3	141.5	114.4	100.5	0.	102.9	202.2	202.4
8	114.4	144.8	230.2	137.0	114.4	99.1	0.	105.5	199.7	200.0
9	114.4	146.1	228.0	131.4	114.4	97.2	0.	109.1	197.2	197.6
HUB	114.3	147.7	226.2	125.4	114.3	94.9	-0.	113.2	195.1	195.1

RP	ABS MACH NO		REL MACH NO		MERID MACH NO		STREAMLINE SLOPE		MERID PEAK SS	
	IN	OUT	IN	OUT	IN	OUT	IN	OUT	VEL R	MACH NO
TIP	0.341	0.380	0.801	0.508	0.341	0.269	-0.45	-0.37	0.818	1.066
1	0.341	0.381	0.795	0.515	0.341	0.278	-0.41	-0.34	0.844	1.060
2	0.341	0.383	0.788	0.518	0.341	0.285	-0.36	-0.30	0.865	1.054
3	0.341	0.385	0.782	0.517	0.341	0.290	-0.32	-0.26	0.878	1.050
4	0.341	0.392	0.762	0.498	0.341	0.294	-0.17	-0.14	0.891	1.035
5	0.340	0.400	0.736	0.469	0.340	0.296	0.03	0.02	0.895	1.013
6	0.340	0.408	0.710	0.438	0.340	0.295	0.24	0.19	0.893	0.989
7	0.340	0.415	0.691	0.408	0.340	0.290	0.40	0.33	0.878	0.972
8	0.340	0.418	0.684	0.395	0.340	0.286	0.46	0.38	0.866	0.967
9	0.340	0.422	0.678	0.379	0.340	0.280	0.51	0.42	0.850	0.964
HUB	0.340	0.426	0.672	0.362	0.340	0.274	0.56	0.47	0.830	0.963

RP	PERCENT SPAN		INCIDENCE MEAN SS		DEV	D-FACT	EFF	LOSS COEFF		LOSS PARAM	
	SPAN	INCIDENCE MEAN SS	DEV	D-FACT				EFF	LOSS TOT	LOSS PROF	LOSS TOT
TIP	0.	1.3	-1.0	4.4	0.452	0.855	0.106	0.106	0.018	0.018	
1	5.00	1.3	-1.1	4.2	0.436	0.892	0.077	0.077	0.013	0.013	
2	10.00	1.3	-1.3	4.1	0.424	0.922	0.055	0.055	0.009	0.009	
3	15.00	1.4	-1.5	4.1	0.419	0.959	0.043	0.043	0.007	0.007	
4	30.00	1.4	-2.0	4.2	0.429	0.950	0.036	0.036	0.006	0.006	
5	50.00	1.5	-2.6	4.6	0.450	0.954	0.035	0.035	0.006	0.006	
6	70.00	1.6	-3.2	5.0	0.475	0.953	0.038	0.038	0.007	0.007	
7	85.00	1.7	-3.6	5.6	0.506	0.938	0.053	0.053	0.010	0.010	
8	90.00	1.7	-3.8	5.8	0.523	0.927	0.065	0.065	0.012	0.012	
9	95.00	1.7	-3.9	6.2	0.545	0.907	0.085	0.085	0.016	0.016	
HUB	100.00	1.7	-4.0	6.5	0.571	0.885	0.108	0.108	0.021	0.021	

TABLE 2. - Concluded.

(c) Blade-element parameters for stator 20

RP	RADII		ABS BETAM		REL BETAM		TOTAL TEMP		TOTAL PRESS	
	IN	OUT	IN	OUT	IN	OUT	IN	RATIO	IN	RATIO
TIP	25.400	25.400	44.9	0.	44.9	0.	311.0	1.000	12.74	0.991
1	25.133	25.109	43.0	-0.	43.0	-0.	310.0	1.000	12.74	0.994
2	24.881	24.859	41.6	-0.	41.6	-0.	309.3	1.000	12.74	0.996
3	24.628	24.610	41.0	0.	41.0	0.	308.9	1.000	12.74	0.996
4	23.871	23.861	41.1	0.	41.1	0.	308.7	1.000	12.74	0.997
5	22.853	22.863	42.2	0.	42.2	0.	308.6	1.000	12.74	0.997
6	21.850	21.864	43.5	0.	43.5	0.	308.6	1.000	12.74	0.996
7	21.092	21.116	45.5	0.	45.5	0.	308.9	1.000	12.74	0.994
8	20.839	20.866	46.6	0.	46.6	0.	309.2	1.000	12.74	0.993
9	20.586	20.616	48.2	0.	48.2	0.	309.6	1.000	12.74	0.990
HUB	20.320	20.320	49.9	-0.	49.9	-0.	310.2	1.000	12.74	0.986

RP	ABS VEL		REL VEL		MERID VEL		TANG VEL		WHEEL SPEED	
	IN	OUT	IN	OUT	IN	OUT	IN	OUT	IN	OUT
TIP	133.1	95.6	133.1	95.6	94.2	95.6	94.0	0.	0.	0.
1	133.1	97.7	133.1	97.7	97.4	97.7	90.8	-0.	0.	0.
2	133.5	99.1	133.5	99.1	99.8	99.1	88.7	-0.	0.	0.
3	134.2	99.9	134.2	99.9	101.3	99.9	85.0	0.	0.	0.
4	136.4	100.6	136.4	100.6	102.7	100.6	89.8	0.	0.	0.
5	139.1	100.5	139.1	100.5	103.1	100.5	95.4	0.	0.	0.
6	141.9	100.0	141.9	100.0	102.8	100.0	97.7	0.	0.	0.
7	144.2	97.7	144.2	97.7	101.0	97.7	102.9	0.	0.	0.
8	145.1	96.2	145.1	96.2	99.6	96.2	105.4	0.	0.	0.
9	146.4	94.2	146.4	94.2	97.6	94.2	109.1	0.	0.	0.
HUB	148.1	91.6	148.1	91.6	95.3	91.6	113.3	-0.	0.	0.

RP	ABS MACH NO		REL MACH NO		MERID MACH NO		STREAMLINE SLOPE		MERID VEL	PEAK SS
	IN	OUT	IN	OUT	IN	OUT	IN	OUT		
TIP	0.382	0.272	0.382	0.272	0.270	0.272	-0.29	-0.21	1.015	0.651
1	0.383	0.279	0.383	0.279	0.280	0.279	-0.26	-0.19	1.003	0.632
2	0.384	0.283	0.384	0.283	0.287	0.283	-0.23	-0.17	0.993	0.620
3	0.387	0.286	0.387	0.286	0.292	0.286	-0.20	-0.15	0.966	0.616
4	0.393	0.288	0.393	0.288	0.296	0.288	-0.11	-0.08	0.979	0.623
5	0.401	0.288	0.401	0.288	0.297	0.288	0.02	0.01	0.975	0.639
6	0.410	0.286	0.410	0.286	0.297	0.286	0.15	0.11	0.972	0.657
7	0.416	0.280	0.416	0.280	0.292	0.280	0.25	0.18	0.958	0.679
8	0.419	0.275	0.419	0.275	0.288	0.275	0.29	0.21	0.966	0.691
9	0.422	0.269	0.422	0.269	0.282	0.269	0.35	0.24	0.965	0.709
HUB	0.427	0.261	0.427	0.261	0.275	0.261	0.36	0.27	0.961	0.730

RP	PERCENT SPAN	INCIDENCE		DEV	D-FACT	EFF	LOSS COEFF		LOSS PARAM	
		MEAN	SS				TOT	PROF	TOT	PROF
TIP	0.	0.2	-4.4	10.7	0.503	0.	0.104	0.104	0.033	0.033
1	5.00	0.2	-4.3	10.0	0.478	0.	0.064	0.064	0.020	0.020
2	10.00	0.2	-4.2	9.6	0.462	0.	0.045	0.045	0.014	0.014
3	15.00	0.2	-4.0	9.4	0.455	0.	0.038	0.038	0.011	0.011
4	30.00	0.1	-3.7	9.3	0.456	0.	0.030	0.030	0.009	0.009
5	50.00	0.1	-3.2	9.3	0.467	0.	0.031	0.031	0.009	0.009
6	70.00	0.1	-2.8	9.4	0.481	0.	0.034	0.034	0.009	0.009
7	85.00	0.1	-2.4	9.7	0.508	0.	0.052	0.052	0.013	0.013
8	90.00	0.1	-2.3	9.9	0.524	0.	0.065	0.065	0.017	0.017
9	95.00	0.1	-2.2	10.2	0.546	0.	0.087	0.087	0.022	0.022
HUB	100.00	0.1	-2.1	10.6	0.574	0.	0.122	0.122	0.031	0.031

TABLE 3. - DESIGN PARAMETERS

FOR STAGE 24A-20

(a) Overall parameters for stage 24A-20

ROTOR TOTAL PRESSURE RATIO.....	1.257
STAGE TOTAL PRESSURE RATIO	1.252
ROTOR TOTAL TEMPERATURE RATIO.....	1.072
STAGE TOTAL TEMPERATURE RATIO	1.072
ROTOR ADIABATIC EFFICIENCY.....	0.940
STAGE ADIABATIC EFFICIENCY	0.921
ROTOR POLYTROPIC EFFICIENCY.....	0.942
STAGE POLYTROPIC EFFICIENCY	0.924
ROTOR HEAD RISE COEFFICIENT.....	0.329
STAGE HEAD RISE COEFFICIENT	0.322
FLOW COEFFICIENT.....	0.470
WT FLOW PER UNIT FRONTAL AREA	46.661
WT FLOW PER UNIT ANNULUS AREA.....	129.614
WT FLOW	9.457
RPM.....	9170.000
TIP SPEED	243.911

TABLE 3. - Continued.

(b) Blade-element parameters for rotor 24A

RP	RADII		ABS BETAM		REL BETAM		TOTAL TEMP		TOTAL PRESS	
	IN	OUT	IN	OUT	IN	OUT	IN	RATIO	IN	RATIO
TIP	25.400	25.400	0.	45.0	64.8	58.0	288.2	1.079	10.13	1.257
1	25.168	25.146	-0.	43.2	64.6	57.3	288.2	1.076	10.13	1.257
2	24.911	24.892	-0.	41.8	64.4	56.6	288.2	1.073	10.13	1.257
3	24.655	24.638	0.	41.2	64.2	55.9	288.2	1.072	10.13	1.257
4	23.886	23.876	0.	41.3	63.4	53.8	288.2	1.071	10.13	1.257
5	22.854	22.860	0.	42.3	62.4	50.9	288.2	1.071	10.13	1.257
6	21.829	21.844	0.	43.7	61.4	47.6	288.2	1.071	10.13	1.257
7	21.055	21.082	0.	45.7	60.5	44.7	288.2	1.072	10.13	1.257
8	20.797	20.828	0.	46.8	60.2	43.7	288.2	1.073	10.13	1.257
9	20.538	20.574	0.	48.3	59.9	42.3	288.2	1.075	10.13	1.257
HUB	20.320	20.320	-0.	50.0	59.6	40.8	288.2	1.076	10.13	1.257

RP	ABS VEL		REL VEL		MERID VEL		TANG VEL		WHEEL SPEED	
	IN	OUT	IN	OUT	IN	OUT	IN	OUT	IN	OUT
TIP	114.6	132.5	269.5	177.0	114.6	93.7	0.	93.8	243.9	243.9
1	114.6	132.6	267.5	179.1	114.6	96.7	-0.	90.7	241.7	241.5
2	114.6	133.0	265.3	180.1	114.6	99.1	-0.	83.7	239.2	239.0
3	114.6	133.7	263.0	179.5	114.6	100.7	0.	83.0	236.8	236.6
4	114.6	135.9	256.4	172.9	114.6	102.1	0.	89.7	229.4	229.3
5	114.5	138.7	247.6	162.5	114.5	102.5	0.	93.4	219.5	219.5
6	114.5	141.5	238.9	151.7	114.5	102.3	0.	97.8	209.6	209.8
7	114.4	143.8	232.3	141.4	114.4	100.5	0.	102.9	202.2	202.4
8	114.4	144.7	230.2	136.9	114.4	99.1	0.	105.5	199.7	200.0
9	114.4	146.1	228.0	131.3	114.4	97.1	0.	109.1	197.2	197.6
HUB	114.4	147.7	226.2	125.3	114.4	94.8	-0.	113.2	195.1	195.1

RP	ABS MACH NO		REL MACH NO		MERID MACH NO		STREAMLINE SLOPE		MERID PEAK SS	
	IN	OUT	IN	OUT	IN	OUT	IN	OUT	VEL R	MACH NO
TIP	0.341	0.380	0.801	0.508	0.341	0.269	-0.30	-0.31	0.818	1.063
1	0.341	0.381	0.795	0.515	0.341	0.276	-0.27	-0.26	0.844	1.062
2	0.341	0.383	0.788	0.518	0.341	0.285	-0.24	-0.25	0.865	1.057
3	0.341	0.385	0.782	0.517	0.341	0.290	-0.21	-0.22	0.878	1.052
4	0.341	0.392	0.762	0.498	0.341	0.294	-0.11	-0.12	0.891	1.038
5	0.340	0.400	0.736	0.469	0.340	0.296	0.02	0.02	0.895	1.015
6	0.340	0.408	0.710	0.438	0.340	0.295	0.16	0.16	0.893	0.991
7	0.340	0.415	0.691	0.408	0.340	0.290	0.27	0.27	0.878	0.973
8	0.340	0.418	0.684	0.395	0.340	0.286	0.30	0.31	0.866	0.968
9	0.340	0.421	0.678	0.379	0.340	0.280	0.34	0.35	0.849	0.965
HUB	0.340	0.426	0.672	0.361	0.340	0.273	0.37	0.39	0.829	0.964

RP	PERCENT SPAN	INCIDENCE		DEV	D-FACT	EFF	LOSS COEFF		LOSS PARAM	
		MEAN	SS				TOT	PROF	TOT	PROF
TIP	0.	1.7	-1.0	4.2	0.452	0.855	0.106	0.106	0.018	0.018
1	5.00	1.8	-1.1	4.0	0.436	0.882	0.077	0.077	0.013	0.013
2	10.00	1.8	-1.3	3.9	0.424	0.922	0.055	0.055	0.009	0.009
3	15.00	1.8	-1.5	3.9	0.419	0.939	0.043	0.043	0.007	0.007
4	30.00	1.9	-2.0	4.1	0.429	0.950	0.033	0.033	0.006	0.006
5	50.00	2.0	-2.6	4.4	0.450	0.954	0.035	0.035	0.006	0.006
6	70.00	2.1	-3.2	4.9	0.475	0.953	0.030	0.030	0.007	0.007
7	85.00	2.1	-3.6	5.4	0.506	0.933	0.033	0.033	0.010	0.010
8	90.00	2.1	-3.8	5.7	0.523	0.927	0.035	0.035	0.012	0.012
9	95.00	2.2	-3.9	6.0	0.546	0.907	0.035	0.035	0.016	0.016
HUB	100.00	2.2	-4.0	6.3	0.571	0.885	0.109	0.109	0.021	0.021

TABLE 3. - Concluded.

(c) Blade-element parameters for stator 20

RP	RADIUS		ABS BETAM		REL BETAM		TOTAL TEMP		TOTAL PRESS	
	IN	OUT	IN	OUT	IN	OUT	IN	RATIO	IN	RATIO
TIP	25.400	25.400	44.9	0.	44.9	0.	311.0	1.000	12.74	0.991
1	25.133	25.109	43.0	-0.	43.0	-0.	310.0	1.000	12.74	0.994
2	24.880	24.859	41.6	-0.	41.6	-0.	309.3	1.000	12.74	0.996
3	24.628	24.609	41.0	0.	41.0	0.	308.9	1.000	12.74	0.996
4	23.871	23.861	41.1	0.	41.1	0.	308.7	1.000	12.74	0.997
5	22.856	22.862	42.2	0.	42.2	0.	308.6	1.000	12.74	0.997
6	21.850	21.864	43.5	0.	43.5	0.	308.6	1.000	12.74	0.996
7	21.092	21.116	45.5	0.	45.5	0.	308.9	1.000	12.74	0.994
8	20.839	20.866	46.6	0.	46.6	0.	309.2	1.000	12.74	0.993
9	20.586	20.616	48.2	0.	48.2	0.	309.6	1.000	12.74	0.990
HUB	20.320	20.320	49.9	-0.	49.9	-0.	310.2	1.000	12.74	0.986

RP	ABS VEL		REL VEL		MERID VEL		TANG VEL		WHEEL SPEED	
	IN	OUT	IN	OUT	IN	OUT	IN	OUT	IN	OUT
TIP	133.1	95.6	133.1	95.6	94.2	95.6	94.0	0.	0.	0.
1	133.1	97.7	133.1	97.7	97.4	97.7	90.8	-0.	0.	0.
2	133.5	99.1	133.5	99.1	99.8	99.1	88.7	-0.	0.	0.
3	134.2	99.9	134.2	99.9	101.3	99.9	88.0	0.	0.	0.
4	136.4	100.6	136.4	100.6	102.7	100.6	89.8	0.	0.	0.
5	139.1	100.5	139.1	100.5	103.1	100.5	93.4	0.	0.	0.
6	141.9	100.0	141.9	100.0	102.8	100.0	97.7	0.	0.	0.
7	144.2	97.7	144.2	97.7	101.0	97.7	102.9	0.	0.	0.
8	145.1	96.2	145.1	96.2	99.6	96.2	105.4	0.	0.	0.
9	146.4	94.2	146.4	94.2	97.6	94.2	109.1	0.	0.	0.
HUB	148.1	91.6	148.1	91.6	95.3	91.6	113.3	-0.	0.	0.

RP	ABS MACH NO		REL MACH NO		MERID MACH NO		STREAMLINE SLOPE		MERID PEAK SS	
	IN	OUT	IN	OUT	IN	OUT	IN	OUT	VEL R	MACH NO
TIP	0.382	0.272	0.382	0.272	0.270	0.272	-0.29	-0.21	1.015	0.651
1	0.383	0.279	0.383	0.279	0.280	0.279	-0.26	-0.19	1.003	0.632
2	0.384	0.283	0.384	0.283	0.287	0.283	-0.23	-0.17	0.993	0.620
3	0.387	0.286	0.387	0.286	0.292	0.286	-0.20	-0.15	0.986	0.616
4	0.393	0.288	0.393	0.288	0.296	0.288	-0.11	-0.08	0.979	0.623
5	0.401	0.288	0.401	0.288	0.297	0.288	0.02	0.01	0.975	0.639
6	0.410	0.286	0.410	0.286	0.297	0.286	0.15	0.11	0.972	0.657
7	0.416	0.280	0.416	0.280	0.292	0.280	0.25	0.18	0.968	0.679
8	0.419	0.275	0.419	0.275	0.288	0.275	0.29	0.21	0.966	0.691
9	0.422	0.269	0.422	0.269	0.282	0.269	0.32	0.24	0.965	0.709
HUB	0.427	0.261	0.427	0.261	0.275	0.261	0.36	0.27	0.961	0.730

RP	PERCENT SPAN		INCIDENCE		DEV	D-FACT	EFF	LOSS COEFF		LOSS PARAM	
	SPAN	MEAN	SS	TOT				PROF	TOT	PROF	
TIP	0.	0.2	-4.4	10.7	0.503	0.	0.104	0.104	0.033	0.033	
1	5.00	0.2	-4.3	10.0	0.478	0.	0.064	0.064	0.020	0.020	
2	10.00	0.2	-4.2	9.6	0.462	0.	0.045	0.045	0.014	0.014	
3	15.00	0.2	-4.0	9.4	0.455	0.	0.036	0.036	0.011	0.011	
4	30.00	0.1	-3.7	9.3	0.456	0.	0.030	0.030	0.009	0.009	
5	50.00	0.1	-3.2	9.3	0.467	0.	0.031	0.031	0.009	0.009	
6	70.00	0.1	-2.8	9.4	0.481	0.	0.034	0.034	0.009	0.009	
7	85.00	0.1	-2.4	9.7	0.508	0.	0.052	0.052	0.013	0.013	
8	90.00	0.1	-2.3	9.9	0.524	0.	0.065	0.065	0.017	0.017	
9	95.00	0.1	-2.2	10.2	0.546	0.	0.087	0.087	0.022	0.022	
HUB	100.00	0.1	-2.1	10.6	0.574	0.	0.122	0.122	0.031	0.031	

TABLE 4. - DESIGN PARAMETERS

FOR STAGE 25A-20B

(a) Overall parameters for stage 25A-20B

ROTOR TOTAL PRESSURE RATIO.....	1.258
STAGE TOTAL PRESSURE RATIO	1.254
ROTOR TOTAL TEMPERATURE RATIO.....	1.066
STAGE TOTAL TEMPERATURE RATIO	1.066
ROTOR ADIABATIC EFFICIENCY.....	0.950
STAGE ADIABATIC EFFICIENCY	0.955
ROTOR POLYTROPIC EFFICIENCY.....	0.951
STAGE POLYTROPIC EFFICIENCY	0.937
ROTOR HEAD RISE COEFFICIENT.....	0.306
STAGE HEAD RISE COEFFICIENT	0.302
FLOW COEFFICIENT.....	0.470
WT FLOW PER UNIT FRONTAL AREA	46.661
WT FLOW PER UNIT ANNULUS AREA.....	129.614
WT FLOW	9.457
RPM.....	9170.000
TIP SPEED	243.911

TABLE 4. - Continued.

(b) Blade-element parameters for rotor 25A

RP	RADII		ABS BETAM		REL BETAM		TOTAL TEMP		TOTAL PRESS	
	IN	OUT	IN	OUT	IN	OUT	IN	RATIO	IN	RATIO
TIP	25.400	25.400	0.	41.1	64.8	58.6	268.2	1.071	10.13	1.238
1	25.167	25.146	-0.	39.9	64.6	58.1	268.2	1.069	10.13	1.238
2	24.911	24.892	-0.	39.1	64.4	57.5	268.2	1.067	10.13	1.238
3	24.655	24.638	0.	38.7	64.2	56.9	268.2	1.066	10.13	1.238
4	23.885	23.876	0.	39.1	63.4	55.1	268.2	1.066	10.13	1.238
5	22.857	22.860	0.	40.2	62.4	52.4	268.2	1.066	10.13	1.238
6	21.829	21.844	0.	41.5	61.3	49.4	268.2	1.066	10.13	1.238
7	21.057	21.082	0.	43.1	60.5	46.7	268.2	1.066	10.13	1.238
8	20.798	20.828	0.	44.0	60.2	45.7	268.2	1.057	10.13	1.238
9	20.540	20.574	0.	45.2	59.9	44.5	268.2	1.063	10.13	1.238
HUB	20.320	20.320	-0.	46.5	59.6	43.2	268.2	1.070	10.13	1.238

RP	ABS VEL		REL VEL		MERID VEL		TANG VEL		WHEEL SPEED	
	IN	OUT	IN	OUT	IN	OUT	IN	OUT	IN	CUT
TIP	114.7	128.9	269.5	186.4	114.7	97.1	0.	84.8	243.9	245.9
1	114.7	129.0	267.5	187.0	114.7	93.9	-0.	82.8	241.7	241.5
2	114.7	129.3	265.3	186.8	114.7	100.3	-0.	81.5	239.2	239.0
3	114.7	129.8	263.1	185.5	114.7	101.3	0.	81.2	236.8	236.6
4	114.6	131.6	256.4	178.5	114.6	102.2	0.	82.9	229.4	229.3
5	114.5	133.9	247.6	168.0	114.5	102.4	0.	86.4	219.5	219.5
6	114.5	136.6	238.9	157.2	114.5	102.3	0.	90.4	209.6	209.8
7	114.5	138.8	232.4	147.7	114.5	101.3	0.	94.9	202.2	202.4
8	114.5	139.7	230.2	143.8	114.5	100.4	0.	97.1	199.7	200.0
9	114.5	140.9	228.1	139.2	114.5	99.2	0.	100.0	197.2	197.6
HUB	114.5	142.2	226.3	134.3	114.5	97.8	-0.	103.2	195.1	195.1

RP	ABS MACH NO		REL MACH NO		MERID MACH NO		STREAMLINE SLOPE		MERID VEL	PEAK SS
	IN	OUT	IN	OUT	IN	OUT	IN	OUT		
TIP	0.341	0.371	0.801	0.536	0.341	0.279	-1.00	-0.65	0.846	1.124
1	0.341	0.372	0.795	0.539	0.341	0.265	-0.90	-0.53	0.862	1.118
2	0.341	0.373	0.789	0.539	0.341	0.280	-0.80	-0.52	0.875	1.113
3	0.341	0.375	0.782	0.535	0.341	0.292	-0.70	-0.45	0.883	1.109
4	0.341	0.380	0.762	0.515	0.341	0.295	-0.58	-0.24	0.891	1.098
5	0.340	0.387	0.736	0.485	0.340	0.296	0.66	0.04	0.894	1.081
6	0.340	0.395	0.710	0.454	0.340	0.296	0.92	0.34	0.893	1.061
7	0.340	0.401	0.691	0.427	0.340	0.293	0.88	0.57	0.884	1.046
8	0.340	0.404	0.684	0.416	0.340	0.290	1.01	0.65	0.877	1.042
9	0.340	0.407	0.678	0.402	0.340	0.287	1.13	0.73	0.866	1.041
HUB	0.340	0.411	0.673	0.388	0.340	0.283	1.24	0.81	0.854	1.040

RP	PERCENT SPAN	INCIDENCE		DEV	D-FACT	EFF	LOSS COEFF		LOSS PARAM	
		MEAN	SS				TOT	PROF	TOT	PROF
TIP	0.	0.2	-1.0	5.2	0.440	0.881	0.080	0.080	0.017	0.017
1	5.00	0.2	-1.1	5.1	0.429	0.911	0.059	0.059	0.013	0.013
2	10.00	0.2	-1.3	5.0	0.422	0.935	0.042	0.042	0.009	0.009
3	15.00	0.3	-1.5	5.0	0.420	0.949	0.034	0.034	0.007	0.007
4	30.00	0.4	-2.0	5.1	0.431	0.958	0.028	0.028	0.006	0.006
5	50.00	0.5	-2.6	5.5	0.453	0.961	0.028	0.028	0.006	0.006
6	70.00	0.6	-3.2	5.9	0.478	0.960	0.030	0.030	0.007	0.007
7	85.00	0.7	-3.6	6.4	0.506	0.948	0.041	0.041	0.010	0.010
8	90.00	0.7	-3.8	6.6	0.520	0.938	0.050	0.050	0.012	0.012
9	95.00	0.7	-3.9	6.9	0.538	0.922	0.065	0.065	0.016	0.016
HUB	100.00	0.7	-4.0	7.2	0.559	0.904	0.083	0.083	0.020	0.020

TABLE 4. - Concluded.

(c) Blade-element parameters for stator 20B

RP	RADII		ABS BETAM		REL BETAM		TOTAL TEMP		TOTAL PRESS	
	IN	OUT	IN	OUT	IN	OUT	IN	RATIO	IN	RATIO
TIP	25.400	25.400	41.3	0.	41.3	0.	308.8	1.000	12.54	0.994
1	25.136	25.105	40.0	-0.	40.0	-0.	308.1	1.000	12.54	0.996
2	24.884	24.855	39.0	-0.	39.0	-0.	307.6	1.000	12.54	0.997
3	24.631	24.606	38.6	0.	38.6	0.	307.3	1.000	12.54	0.997
4	23.872	23.859	38.9	0.	38.9	0.	307.1	1.000	12.54	0.998
5	22.858	22.866	39.9	0.	39.9	0.	307.0	1.000	12.54	0.998
6	21.848	21.867	41.3	0.	41.3	0.	307.1	1.000	12.54	0.997
7	21.089	21.120	43.1	0.	43.1	0.	307.3	1.000	12.54	0.996
8	20.836	20.871	44.1	0.	44.1	0.	307.5	1.000	12.54	0.995
9	20.583	20.622	45.4	0.	45.4	0.	307.9	1.000	12.54	0.995
HUB	20.320	20.320	46.8	-0.	46.8	-0.	308.3	1.000	12.54	0.991

RP	ABS VEL		REL VEL		MERID VEL		TANG VEL		WHEEL SPEED	
	IN	OUT	IN	OUT	IN	OUT	IN	OUT	IN	OUT
TIP	128.6	98.3	128.6	98.3	96.6	98.3	84.9	0.	0.	0.
1	128.9	99.5	128.9	99.5	98.8	99.5	82.8	-0.	0.	0.
2	129.4	100.4	129.4	100.4	100.5	100.4	81.5	-0.	0.	0.
3	130.1	100.9	130.1	100.9	101.6	100.9	81.2	0.	0.	0.
4	132.2	101.3	132.2	101.3	102.9	101.3	82.9	0.	0.	0.
5	134.6	101.2	134.6	101.2	103.3	101.2	86.4	0.	0.	0.
6	136.9	100.9	136.9	100.9	102.9	100.9	90.4	0.	0.	0.
7	138.7	99.5	138.7	99.5	101.2	99.5	94.9	0.	0.	0.
8	139.4	98.6	139.4	98.6	100.1	98.6	97.0	0.	0.	0.
9	140.4	97.4	140.4	97.4	98.6	97.4	99.9	0.	0.	0.
HUB	141.6	95.7	141.6	95.7	96.9	95.7	103.3	-0.	0.	0.

RP	ABS MACH NO		REL MACH NO		MERID MACH NO		STREAMLINE SLOPE		MERID PEAK SS	
	IN	OUT	IN	OUT	IN	OUT	IN	OUT	VEL R	PEAK MACH NO
TIP	0.370	0.281	0.370	0.281	0.278	0.281	-0.29	-0.21	1.017	0.583
1	0.371	0.285	0.371	0.285	0.285	0.285	-0.26	-0.19	1.007	0.576
2	0.373	0.288	0.373	0.288	0.290	0.288	-0.23	-0.17	0.999	0.569
3	0.375	0.290	0.375	0.290	0.293	0.290	-0.20	-0.15	0.993	0.568
4	0.382	0.291	0.382	0.291	0.297	0.291	-0.11	-0.08	0.985	0.576
5	0.389	0.290	0.389	0.290	0.298	0.290	0.02	0.01	0.980	0.589
6	0.396	0.290	0.396	0.290	0.297	0.290	0.15	0.11	0.981	0.605
7	0.401	0.286	0.401	0.286	0.293	0.286	0.25	0.18	0.983	0.623
8	0.403	0.283	0.403	0.283	0.289	0.283	0.29	0.21	0.985	0.631
9	0.406	0.279	0.406	0.279	0.285	0.279	0.32	0.24	0.988	0.643
HUB	0.409	0.274	0.409	0.274	0.280	0.274	0.36	0.27	0.988	0.657

RP	PERCENT SPAN	INCIDENCE		DEV	D-FACT	EFF	LOSS COEFF		LOSS PARAM	
		MEAN	SS				TOT	PROF	TOT	PROF
TIP	0.	-3.4	-8.0	10.7	0.505	0.	0.000	0.080	0.033	0.033
1	5.00	-2.9	-7.3	10.0	0.487	0.	0.048	0.048	0.019	0.019
2	10.00	-2.4	-6.8	9.6	0.476	0.	0.034	0.034	0.014	0.014
3	15.00	-2.2	-6.4	9.4	0.471	0.	0.027	0.027	0.011	0.011
4	30.00	-2.1	-6.0	9.3	0.474	0.	0.022	0.022	0.008	0.008
5	50.00	-2.1	-5.5	9.3	0.484	0.	0.023	0.023	0.009	0.009
6	70.00	-2.1	-5.0	9.4	0.495	0.	0.025	0.025	0.009	0.009
7	85.00	-2.3	-4.8	9.7	0.514	0.	0.039	0.039	0.013	0.013
8	90.00	-2.4	-4.9	9.9	0.526	0.	0.048	0.048	0.016	0.016
9	95.00	-2.7	-5.0	10.2	0.542	0.	0.065	0.065	0.021	0.021
HUB	100.00	-3.0	-5.2	10.6	0.562	0.	0.093	0.093	0.030	0.030

TABLE 5. - DESIGN PARAMETERS

FOR STAGE 26B-21

(a) Overall parameters for stage 26B-21

ROTOR TOTAL PRESSURE RATIO.....	1.328
STAGE TOTAL PRESSURE RATIO	1.318
ROTOR TOTAL TEMPERATURE RATIO.....	1.090
STAGE TOTAL TEMPERATURE RATIO	1.090
ROTOR ADIABATIC EFFICIENCY.....	0.958
STAGE ADIABATIC EFFICIENCY	0.913
ROTOR POLYTROPIC EFFICIENCY.....	0.941
STAGE POLYTROPIC EFFICIENCY	0.916
ROTOR HEAD RISE COEFFICIENT.....	0.411
STAGE HEAD RISE COEFFICIENT	0.400
FLOW COEFFICIENT.....	0.469
WT FLOW PER UNIT FRONTAL AREA	46.661
WT FLOW PER UNIT ANNULUS AREA.....	129.614
WT FLOW	9.457
RPM.....	9170.000
TIP SPEED	243.911

TABLE 5. - Continued.

(b) Blade-element parameters for rotor 26B

RP	RADII		ABS BETAM		REL BETAM		TOTAL TEMP		TOTAL PRESS	
	IN	OUT	IN	OUT	IN	OUT	IN	RATIO	IN	RATIO
TIP	25.400	25.400	0.	54.4	65.2	55.5	268.2	1.101	10.13	1.328
1	25.176	25.146	-0.	51.4	64.9	54.1	268.2	1.096	10.13	1.328
2	24.926	24.892	-0.	49.2	64.5	55.0	268.2	1.092	10.13	1.328
3	24.672	24.638	0.	48.0	64.2	52.6	268.2	1.090	10.13	1.328
4	23.895	23.876	0.	47.9	63.4	49.2	268.2	1.089	10.13	1.328
5	22.851	22.860	0.	48.9	62.4	45.4	268.2	1.088	10.13	1.328
6	21.807	21.844	0.	50.4	61.3	40.0	268.2	1.089	10.13	1.328
7	21.028	21.082	0.	52.8	60.5	36.8	268.2	1.090	10.13	1.328
8	20.774	20.828	0.	54.3	60.2	35.2	268.2	1.092	10.13	1.328
9	20.526	20.574	0.	56.5	60.0	33.1	268.2	1.094	10.13	1.328
HUB	20.320	20.320	-0.	58.9	59.7	30.6	268.2	1.097	10.13	1.328

RP	ABS VEL		REL VEL		MERID VEL		TANG VEL		WHEEL SPEED	
	IN	OUT	IN	OUT	IN	OUT	IN	OUT	IN	OUT
TIP	112.9	147.3	268.8	151.0	112.9	85.9	0.	119.7	243.9	243.9
1	113.4	146.9	267.0	156.3	113.4	91.6	-0.	114.8	241.8	241.5
2	114.0	147.1	265.1	159.8	114.0	96.2	-0.	111.4	239.4	239.0
3	114.4	148.0	263.1	160.6	114.4	99.0	0.	110.1	236.9	236.6
4	114.8	150.9	256.6	154.9	114.8	101.1	0.	112.0	229.5	229.3
5	114.8	154.7	247.6	144.6	114.8	101.6	0.	116.6	219.4	219.5
6	114.6	158.8	238.7	135.8	114.6	101.3	0.	122.3	209.4	209.8
7	114.2	162.1	232.0	122.5	114.2	98.1	0.	129.0	201.9	202.4
8	114.1	163.4	229.8	116.6	114.1	95.3	0.	132.8	199.5	200.0
9	114.0	165.5	227.7	109.0	114.0	91.3	0.	138.1	197.1	197.6
HUB	113.9	168.0	225.9	100.7	113.9	86.7	-0.	143.9	195.1	195.1

RP	ABS MACH NO		REL MACH NO		MERID MACH NO		STREAMLINE SLOPE		MERID PEAK SS	
	IN	OUT	IN	OUT	IN	OUT	IN	OUT	VEL R	MACH NO
TIP	0.335	0.420	0.799	0.450	0.335	0.245	-0.52	-0.59	0.760	1.097
1	0.337	0.420	0.794	0.446	0.337	0.262	-0.63	-0.46	0.308	1.093
2	0.339	0.421	0.788	0.457	0.339	0.275	-0.70	-0.50	0.344	1.089
3	0.340	0.424	0.782	0.460	0.340	0.284	-0.80	-0.48	0.365	1.065
4	0.341	0.433	0.767	0.444	0.341	0.290	-0.36	-0.27	0.681	1.071
5	0.341	0.444	0.736	0.415	0.341	0.292	0.16	0.07	0.885	1.050
6	0.341	0.456	0.710	0.385	0.341	0.291	0.64	0.37	0.884	1.028
7	0.339	0.466	0.690	0.352	0.339	0.282	0.69	0.54	0.859	1.013
8	0.339	0.470	0.683	0.335	0.339	0.274	0.87	0.56	0.635	1.010
9	0.339	0.475	0.677	0.313	0.339	0.262	0.77	0.53	0.801	1.012
HUB	0.338	0.482	0.672	0.289	0.338	0.249	0.65	0.50	0.762	1.014

RP	PERCENT SPAN	INCIDENCE		DEV	D-FACT	EFF	LOSS COEFF		LOSS PARAM	
		MEAN	SS				TOT	PROF	TOT	PROF
TIP	0.	1.1	-1.0	5.9	0.562	0.837	0.150	0.150	0.024	0.024
1	5.00	1.1	-1.1	5.5	0.533	0.831	0.106	0.106	0.017	0.017
2	10.00	1.1	-1.3	5.3	0.512	0.918	0.071	0.071	0.012	0.012
3	15.00	1.2	-1.4	5.2	0.502	0.939	0.053	0.053	0.009	0.009
4	30.00	1.2	-1.9	5.4	0.511	0.952	0.043	0.043	0.007	0.007
5	50.00	1.3	-2.6	5.9	0.534	0.954	0.043	0.043	0.008	0.008
6	70.00	1.4	-3.2	6.5	0.562	0.953	0.047	0.047	0.009	0.009
7	85.00	1.4	-3.6	7.2	0.601	0.935	0.068	0.068	0.013	0.013
8	90.00	1.4	-3.8	7.6	0.625	0.920	0.087	0.087	0.016	0.016
9	95.00	1.4	-3.9	8.1	0.658	0.896	0.117	0.117	0.022	0.022
HUB	100.00	1.4	-4.0	8.4	0.696	0.870	0.153	0.153	0.029	0.029

TABLE 5. - Concluded.

(c) Blade-element parameters for stator 21

RP	RADII		ABS BETAM		REL BETAM		TOTAL TEMP		TOTAL PRESS	
	IN	OUT	IN	OUT	IN	OUT	IN	RATIO	IN	RATIO
TIP	25.400	25.400	54.7	0.	54.7	0.	317.3	1.000	13.45	0.984
1	25.132	25.112	51.5	-0.	51.5	-0.	315.8	1.000	13.45	0.989
2	24.878	24.867	49.1	-0.	49.1	-0.	314.7	1.000	13.45	0.993
3	24.625	24.622	47.9	0.	47.9	0.	314.1	1.000	13.45	0.995
4	23.869	23.876	47.6	0.	47.6	0.	313.7	1.000	13.45	0.995
5	22.862	22.883	48.7	0.	48.7	0.	313.7	1.000	13.45	0.995
6	21.852	21.889	50.2	0.	50.2	0.	313.7	1.000	13.45	0.994
7	21.093	21.138	52.7	0.	52.7	0.	314.2	1.000	13.45	0.990
8	20.859	20.885	54.3	0.	54.3	0.	314.6	1.000	13.45	0.986
9	20.586	20.622	56.5	0.	56.5	0.	315.3	1.000	13.45	0.978
HUB	20.320	20.320	59.0	-0.	59.0	-0.	316.2	1.000	13.45	0.968

RP	ABS VEL		REL VEL		MERID VEL		TANG VEL		WHEEL SPEED	
	IN	OUT	IN	OUT	IN	OUT	IN	OUT	IN	OUT
TIP	147.1	87.7	147.1	87.7	85.0	87.7	120.0	0.	0.	0.
1	146.9	92.2	146.9	92.2	91.5	92.2	114.9	-0.	0.	0.
2	147.3	95.2	147.3	95.2	96.4	95.2	111.4	-0.	0.	0.
3	148.4	97.2	148.4	97.2	99.5	97.2	110.1	0.	0.	0.
4	151.6	98.6	151.6	98.6	102.1	98.6	112.0	0.	0.	0.
5	155.2	98.5	155.2	98.5	102.4	98.5	116.6	0.	0.	0.
6	159.1	97.3	159.1	97.3	101.8	97.3	122.2	0.	0.	0.
7	162.1	91.6	162.1	91.6	98.3	91.6	129.0	0.	0.	0.
8	163.5	87.0	163.5	87.0	95.4	87.0	132.7	0.	0.	0.
9	165.5	80.5	165.5	80.5	91.4	80.5	138.0	0.	0.	0.
HUB	168.1	72.1	168.1	72.1	86.6	72.1	144.1	-0.	0.	0.

RP	ABS MACH NO		REL MACH NO		MERID MACH NO		STREAMLINE SLOPE		MERID PEAK SS	
	IN	OUT	IN	OUT	IN	OUT	IN	OUT	VEL R	MACH NO
TIP	0.419	0.247	0.419	0.247	0.242	0.247	-0.33	-0.32	1.031	0.781
1	0.419	0.260	0.419	0.260	0.261	0.260	-0.21	-0.20	1.007	0.745
2	0.422	0.270	0.422	0.270	0.276	0.270	-0.12	-0.11	0.988	0.722
3	0.425	0.276	0.425	0.276	0.285	0.276	-0.06	-0.05	0.977	0.713
4	0.435	0.280	0.435	0.280	0.293	0.280	0.04	0.09	0.966	0.721
5	0.446	0.280	0.446	0.280	0.294	0.280	0.15	0.25	0.962	0.740
6	0.457	0.276	0.457	0.276	0.293	0.276	0.27	0.44	0.956	0.764
7	0.466	0.259	0.466	0.259	0.283	0.259	0.36	0.53	0.932	0.795
8	0.470	0.246	0.470	0.246	0.274	0.246	0.37	0.51	0.912	0.813
9	0.475	0.227	0.475	0.227	0.262	0.227	0.37	0.42	0.881	0.841
HUB	0.483	0.203	0.483	0.203	0.249	0.203	0.36	0.29	0.833	0.875

RP	PERCENT SPAN	INCIDENCE		DEV	D-FACT	EFF	LOSS COEFF		LOSS PARAM	
		MEAN	SS				TOT	PROF	TOT	PROF
TIP	0.	-1.0	-5.1	12.9	0.631	0.	0.157	0.157	0.044	0.044
1	5.00	-1.0	-5.0	11.9	0.588	0.	0.095	0.095	0.026	0.026
2	10.00	-1.0	-4.9	11.2	0.560	0.	0.063	0.063	0.017	0.017
3	15.00	-1.0	-4.8	10.8	0.546	0.	0.046	0.046	0.013	0.013
4	30.00	-1.0	-4.5	10.5	0.543	0.	0.037	0.037	0.010	0.010
5	50.00	-1.0	-4.0	10.5	0.554	0.	0.039	0.039	0.010	0.010
6	70.00	-0.9	-3.5	10.6	0.572	0.	0.044	0.044	0.011	0.011
7	85.00	-0.9	-3.2	11.0	0.619	0.	0.074	0.074	0.017	0.017
8	90.00	-0.9	-3.1	11.3	0.653	0.	0.102	0.102	0.023	0.023
9	95.00	-0.9	-2.9	11.8	0.702	0.	0.151	0.151	0.034	0.034
HUB	100.00	-1.0	-2.9	12.4	0.762	0.	0.220	0.220	0.049	0.049

TABLE 6. - DESIGN PARAMETERS
FOR STAGE 27A-21

(a) Overall parameters for stage 27A-21

ROTOR TOTAL PRESSURE RATIO.....	1.328
STAGE TOTAL PRESSURE RATIO	1.318
ROTOR TOTAL TEMPERATURE RATIO.....	1.090
STAGE TOTAL TEMPERATURE RATIO	1.090
ROTOR ADIABATIC EFFICIENCY.....	0.938
STAGE ADIABATIC EFFICIENCY	0.913
ROTOR POLYTROPIC EFFICIENCY.....	0.941
STAGE POLYTROPIC EFFICIENCY	0.916
ROTOR HEAD RISE COEFFICIENT.....	0.411
STAGE HEAD RISE COEFFICIENT	0.400
FLOW COEFFICIENT.....	0.469
WT FLOW PER UNIT FRONTAL AREA	46.661
WT FLOW PER UNIT ANNULUS AREA.....	129.614
WT FLOW	9.457
RPM.....	9170.000
TIP SPEED	243.911

TABLE 6. - Continued.

(b) Blade-element parameters for rotor 27A

RP	RADIO		ABS BETAM		REL BETAM		TOTAL TEMP		TOTAL PRESS	
	IN	OUT	IN	OUT	IN	OUT	IN	RATIO	IN	RATIO
TIP	25.400	25.400	0.	54.5	65.2	55.4	288.2	1.101	10.13	1.328
1	25.177	25.146	-0.	51.5	64.9	54.2	288.2	1.096	10.13	1.328
2	24.927	24.892	-0.	49.2	64.5	53.0	288.2	1.092	10.13	1.328
3	24.673	24.638	0.	48.0	64.2	52.0	288.2	1.090	10.13	1.328
4	23.895	23.876	0.	47.9	63.4	49.2	288.2	1.069	10.13	1.328
5	22.852	22.860	0.	48.9	62.4	45.3	288.2	1.088	10.13	1.328
6	21.806	21.844	0.	50.3	61.3	40.8	288.2	1.089	10.13	1.328
7	21.027	21.082	0.	52.8	60.5	36.8	288.2	1.090	10.13	1.328
8	20.773	20.828	0.	54.4	60.2	35.2	288.2	1.092	10.13	1.328
9	20.525	20.574	0.	56.6	60.0	33.1	288.2	1.094	10.13	1.328
HUB	20.320	20.320	-0.	59.0	59.7	30.6	288.2	1.097	10.13	1.328

RP	ABS VEL		REL VEL		MERID VEL		TANG VEL		WHEEL SPEED	
	IN	OUT	IN	OUT	IN	OUT	IN	OUT	IN	OUT
TIP	112.9	147.2	268.8	150.7	112.9	85.5	0.	119.8	243.9	243.9
1	113.5	146.8	267.1	156.1	113.5	91.4	-0.	114.9	241.8	241.5
2	114.0	147.1	265.1	159.8	114.0	96.1	-0.	111.4	239.4	239.0
3	114.4	148.0	263.1	160.6	114.4	98.9	0.	110.0	236.9	236.6
4	114.8	151.0	256.6	154.9	114.8	101.2	0.	112.0	229.5	229.3
5	114.7	154.8	247.6	144.7	114.7	101.8	0.	116.6	219.4	219.5
6	114.5	156.8	238.7	133.9	114.5	101.4	0.	122.3	209.4	209.8
7	114.1	162.0	231.9	122.4	114.1	98.0	0.	129.0	201.9	202.4
8	114.0	163.4	229.8	116.5	114.0	95.2	0.	132.8	199.5	200.0
9	113.9	165.4	227.7	108.8	113.9	91.1	0.	138.1	197.1	197.6
HUB	113.9	168.0	225.9	100.4	113.9	66.5	-0.	144.0	195.1	195.1

RP	ABS MACH NO		REL MACH NO		MERID MACH NO		STREAMLINE SLOPE		MERID VEL R	PEAK SS MACH NO
	IN	OUT	IN	OUT	IN	OUT	IN	OUT		
TIP	0.336	0.420	0.799	0.429	0.336	0.244	-0.00	-0.31	0.757	1.099
1	0.337	0.419	0.794	0.446	0.337	0.261	-0.05	-0.32	0.805	1.095
2	0.339	0.421	0.788	0.457	0.339	0.276	-0.00	-0.33	0.843	1.091
3	0.340	0.424	0.782	0.460	0.340	0.285	-0.07	-0.31	0.805	1.087
4	0.341	0.433	0.763	0.444	0.341	0.290	-0.00	-0.17	0.802	1.073
5	0.341	0.444	0.736	0.416	0.341	0.292	0.00	0.05	0.867	1.052
6	0.340	0.457	0.709	0.385	0.340	0.291	0.04	0.22	0.805	1.029
7	0.339	0.466	0.689	0.352	0.339	0.292	0.40	0.35	0.859	1.013
8	0.339	0.470	0.683	0.335	0.339	0.275	0.46	0.37	0.835	1.010
9	0.339	0.475	0.677	0.312	0.339	0.262	0.43	0.38	0.799	1.011
HUB	0.338	0.482	0.671	0.286	0.338	0.248	0.37	0.39	0.759	1.013

RP	PERCENT		INCIDENCE		DEV	D-FACT	EFF	LOSS COEFF		LOSS PARAM	
	SPAN		MEAN	SS				TOT	PROF	TOT	PROF
TIP	0.		1.6	-1.0	5.7	0.564	0.836	0.150	0.150	0.024	0.024
1	5.00		1.7	-1.1	5.3	0.534	0.801	0.160	0.163	0.017	0.017
2	10.00		1.7	-1.3	5.1	0.512	0.910	0.071	0.071	0.012	0.012
3	15.00		1.7	-1.4	5.0	0.502	0.959	0.055	0.055	0.009	0.009
4	30.00		1.8	-1.9	5.2	0.510	0.952	0.045	0.043	0.007	0.007
5	50.00		1.9	-2.6	5.7	0.534	0.955	0.045	0.043	0.007	0.007
6	70.00		1.9	-3.2	6.3	0.562	0.955	0.047	0.047	0.009	0.009
7	85.00		2.0	-3.6	7.0	0.601	0.955	0.033	0.038	0.013	0.013
8	90.00		2.0	-3.8	7.4	0.625	0.920	0.037	0.067	0.016	0.016
9	95.00		2.0	-3.9	7.9	0.659	0.896	0.118	0.118	0.022	0.022
HUB	100.00		1.9	-4.0	8.2	0.697	0.869	0.153	0.153	0.029	0.029

TABLE 6. - Concluded.

(c) Blade-element parameters for stator 21

RP	RADII		ABS BETAM		REL BETAM		TOTAL TEMP		TOTAL PRESS	
	IN	OUT	IN	OUT	IN	OUT	IN	RATIO	IN	RATIO
TIP	25.400	25.400	54.7	0.	54.7	0.	317.3	1.000	13.45	0.984
1	25.132	25.113	51.5	-0.	51.5	-0.	315.8	1.000	13.45	0.989
2	24.878	24.867	49.1	-0.	49.1	-0.	314.7	1.000	13.45	0.993
3	24.625	24.622	47.9	0.	47.9	0.	314.1	1.000	13.45	0.995
4	23.870	23.877	47.6	0.	47.6	0.	313.7	1.000	13.45	0.995
5	22.862	22.883	48.7	0.	48.7	0.	313.7	1.000	13.45	0.995
6	21.851	21.888	50.2	0.	50.2	0.	313.7	1.000	13.45	0.994
7	21.092	21.137	52.7	0.	52.7	0.	314.2	1.000	13.45	0.990
8	20.838	20.882	54.3	0.	54.3	0.	314.6	1.000	13.45	0.966
9	20.585	20.622	56.5	0.	56.5	0.	315.5	1.000	13.45	0.978
HUB	20.320	20.320	59.0	-0.	59.0	-0.	316.2	1.000	13.45	0.968

RP	ABS VEL		REL VEL		MERID VEL		TANG VEL		WHEEL SPEED	
	IN	OUT	IN	OUT	IN	OUT	IN	OUT	IN	OUT
TIP	147.1	87.7	147.1	87.7	85.0	87.7	120.0	0.	0.	0.
1	146.9	92.1	146.9	92.1	91.5	92.1	114.9	-0.	0.	0.
2	147.3	95.2	147.3	95.2	96.4	95.2	111.4	-0.	0.	0.
3	148.4	97.2	148.4	97.2	99.5	97.2	110.1	0.	0.	0.
4	151.6	98.6	151.6	98.6	102.1	98.6	112.0	0.	0.	0.
5	155.2	98.5	155.2	98.5	102.4	98.5	116.6	0.	0.	0.
6	159.1	97.3	159.1	97.3	101.8	97.3	122.2	0.	0.	0.
7	162.2	91.6	162.2	91.6	98.3	91.6	129.0	0.	0.	0.
8	163.5	87.0	163.5	87.0	95.4	87.0	132.7	0.	0.	0.
9	165.5	80.5	165.5	80.5	91.4	80.5	138.0	0.	0.	0.
HUB	168.1	72.1	168.1	72.1	86.6	72.1	144.1	-0.	0.	0.

RP	ABS MACH NO		REL MACH NO		MERID MACH NO		STREAMLINE SLOPE		MERID VEL	PEAK SS
	IN	OUT	IN	OUT	IN	OUT	IN	OUT		
TIP	0.419	0.247	0.419	0.247	0.242	0.247	-0.53	-0.32	1.031	0.781
1	0.419	0.260	0.419	0.260	0.261	0.260	-0.21	-0.20	1.007	0.745
2	0.422	0.270	0.422	0.270	0.276	0.270	-0.12	-0.11	0.988	0.722
3	0.425	0.276	0.425	0.276	0.285	0.276	-0.06	-0.05	0.977	0.713
4	0.435	0.280	0.435	0.280	0.293	0.280	0.04	0.05	0.966	0.721
5	0.446	0.280	0.446	0.280	0.294	0.280	0.15	0.25	0.962	0.740
6	0.457	0.276	0.457	0.276	0.293	0.276	0.27	0.44	0.956	0.764
7	0.466	0.259	0.466	0.259	0.263	0.259	0.36	0.53	0.952	0.795
8	0.470	0.246	0.470	0.246	0.274	0.246	0.37	0.51	0.912	0.814
9	0.475	0.227	0.475	0.227	0.262	0.227	0.37	0.42	0.881	0.842
HUB	0.483	0.203	0.483	0.203	0.249	0.203	0.36	0.29	0.833	0.875

RP	PERCENT SPAN	INCIDENCE		DEV	D-FACT	EFF	LOSS COEFF		LOSS PARAM	
		MEAN	SS				TOT	PROF	TOT	PROF
TIP	0.	-1.0	-5.1	12.9	0.631	0.	0.157	0.157	0.044	0.044
1	5.00	-1.0	-5.0	11.9	0.588	0.	0.095	0.095	0.026	0.026
2	10.00	-1.0	-4.9	11.2	0.560	0.	0.063	0.063	0.017	0.017
3	15.00	-1.0	-4.8	10.8	0.546	0.	0.047	0.047	0.013	0.013
4	30.00	-1.0	-4.5	10.5	0.543	0.	0.037	0.037	0.010	0.010
5	50.00	-1.0	-4.0	10.5	0.554	0.	0.039	0.039	0.010	0.010
6	70.00	-0.9	-3.5	10.6	0.572	0.	0.044	0.044	0.011	0.011
7	85.00	-0.9	-3.2	11.0	0.620	0.	0.074	0.074	0.017	0.017
8	90.00	-0.9	-3.1	11.3	0.654	0.	0.102	0.102	0.023	0.023
9	95.00	-0.9	-2.9	11.8	0.702	0.	0.151	0.151	0.034	0.034
HUB	100.00	-1.0	-2.9	12.4	0.762	0.	0.220	0.220	0.049	0.049

TABLE 7. - DESIGN PARAMETERS

FOR STAGE 28B-22

(a) Overall parameters for stage 28B-22

ROTOR TOTAL PRESSURE RATIO.....	1.599
STAGE TOTAL PRESSURE RATIO	1.381
ROTOR TOTAL TEMPERATURE RATIO.....	1.107
STAGE TOTAL TEMPERATURE RATIO	1.107
ROTOR ADIABATIC EFFICIENCY.....	0.959
STAGE ADIABATIC EFFICIENCY	0.931
ROTOR POLYTROPIC EFFICIENCY.....	0.942
STAGE POLYTROPIC EFFICIENCY	0.905
ROTOR HEAD RISE COEFFICIENT.....	0.490
STAGE HEAD RISE COEFFICIENT	0.470
FLOW COEFFICIENT.....	0.469
WT FLOW PER UNIT FRONTAL AREA	46.661
WT FLOW PER UNIT ANNULUS AREA.....	129.614
WT FLOW	9.457
RPM.....	9170.000
TIP SPEED	243.911

TABLE 7. - Continued.

(b) Blade-element parameters for rotor 28B

RP	RADII		ABS BETAM		REL BETAM		TOTAL TEMP		TOTAL PRESS	
	IN	OUT	IN	OUT	IN	OUT	IN	RATIO	IN	RATIO
TIP	25.400	25.400	0.	63.8	65.6	53.3	288.2	1.124	10.13	1.399
1	25.191	25.146	-0.	58.8	65.2	50.6	288.2	1.116	10.13	1.399
2	24.952	24.892	-0.	54.9	64.7	48.6	288.2	1.110	10.13	1.399
3	24.701	24.638	0.	52.9	64.3	47.0	288.2	1.107	10.13	1.399
4	23.905	23.876	0.	52.6	63.4	43.3	288.2	1.106	10.13	1.399
5	22.831	22.860	0.	53.6	62.4	38.3	288.2	1.105	10.13	1.399
6	21.757	21.844	0.	55.2	61.3	32.4	288.2	1.106	10.13	1.399
7	20.971	21.082	0.	58.4	60.4	27.1	288.2	1.108	10.13	1.399
8	20.730	20.828	0.	60.9	60.1	24.6	288.2	1.110	10.13	1.399
9	20.503	20.574	0.	64.2	59.7	20.9	288.2	1.114	10.13	1.399
HUB	20.320	20.320	-0.	67.8	59.4	15.8	288.2	1.118	10.13	1.399

RP	ABS VEL		REL VEL		MERID VEL		TANG VEL		WHEEL SPEED	
	IN	OUT	IN	OUT	IN	OUT	IN	OUT	IN	OUT
TIP	110.7	163.8	267.9	121.0	110.7	72.4	0.	147.0	243.9	243.9
1	112.0	162.4	266.6	132.7	112.0	84.2	-0.	138.9	241.9	241.5
2	113.2	162.6	265.0	141.3	113.2	93.5	-0.	133.0	239.6	239.0
3	114.1	163.9	263.2	144.9	114.1	98.9	0.	130.6	237.2	236.6
4	114.9	167.7	256.7	140.1	114.9	101.9	0.	133.2	229.6	229.3
5	114.8	172.4	247.5	130.3	114.8	102.2	0.	138.8	219.2	219.5
6	114.6	177.3	238.3	119.9	114.6	101.2	0.	145.6	208.9	209.8
7	114.4	180.7	231.6	106.3	114.4	94.6	0.	154.0	201.4	202.4
8	114.6	182.4	229.7	97.6	114.6	88.7	0.	159.4	199.1	200.0
9	114.9	185.2	228.0	86.2	114.9	80.6	0.	166.8	196.9	197.6
HUB	115.2	189.0	226.6	74.3	115.2	71.5	-0.	174.9	195.1	195.1

RP	ABS MACH NO		REL MACH NO		MERID MACH NO		STREAMLINE SLOPE		MERID PEAK SS	
	IN	OUT	IN	OUT	IN	OUT	IN	OUT	VEL R	MACH NO
TIP	0.329	0.464	0.796	0.343	0.329	0.205	-0.31	-0.30	0.654	1.158
1	0.333	0.461	0.792	0.377	0.333	0.239	-0.52	-0.42	0.752	1.161
2	0.336	0.463	0.788	0.403	0.336	0.266	-0.68	-0.49	0.826	1.165
3	0.339	0.468	0.782	0.414	0.339	0.282	-0.71	-0.49	0.867	1.163
4	0.342	0.479	0.763	0.400	0.342	0.291	-0.32	-0.27	0.887	1.150
5	0.341	0.493	0.736	0.373	0.341	0.293	0.27	0.04	0.891	1.130
6	0.341	0.508	0.708	0.344	0.341	0.290	0.81	0.25	0.884	1.107
7	0.340	0.518	0.688	0.305	0.340	0.271	1.04	0.25	0.827	1.093
8	0.341	0.523	0.683	0.280	0.341	0.254	0.91	0.28	0.775	1.096
9	0.342	0.530	0.678	0.247	0.342	0.231	0.64	0.34	0.701	1.105
HUB	0.342	0.540	0.674	0.212	0.342	0.204	0.37	0.43	0.620	1.115

RP	PERCENT		INCIDENCE		DEV	D-FACT	EFF	LOSS COEFF		LOSS PARAM	
	SPAN		MEAN	SS				TOT	PROF	TOT	PROF
TIP	0.		1.5	-1.0	8.1	0.701	0.813	0.206	0.206	0.034	0.034
1	5.00		1.5	-1.1	7.1	0.646	0.869	0.138	0.138	0.024	0.024
2	10.00		1.5	-1.3	6.6	0.604	0.916	0.085	0.085	0.015	0.015
3	15.00		1.6	-1.4	6.5	0.583	0.943	0.058	0.058	0.011	0.011
4	30.00		1.6	-1.9	6.8	0.590	0.954	0.048	0.048	0.009	0.009
5	50.00		1.7	-2.6	7.4	0.614	0.956	0.048	0.048	0.009	0.009
6	70.00		1.7	-3.2	8.2	0.643	0.954	0.054	0.054	0.011	0.011
7	85.00		1.7	-3.7	9.1	0.695	0.935	0.081	0.081	0.017	0.017
8	90.00		1.7	-3.8	9.8	0.734	0.914	0.110	0.110	0.023	0.023
9	95.00		1.7	-3.9	10.5	0.787	0.884	0.154	0.154	0.032	0.032
HUB	100.00		1.6	-4.0	10.2	0.844	0.853	0.203	0.203	0.044	0.044

TABLE 7. - Concluded.

(c) Blade-element parameters for stator 22

RP	RADII		ABS BETAM		REL BETAM		TOTAL TEMP		TOTAL PRESS	
	IN	OUT	IN	OUT	IN	OUT	IN	RATIO	IN	RATIO
TIP	25.400	25.400	64.4	0.	64.4	0.	523.9	1.001	14.17	0.971
1	25.131	25.128	59.0	-0.	59.0	-0.	321.6	1.000	14.17	0.982
2	24.875	24.901	55.0	-0.	55.0	-0.	319.8	1.000	14.17	0.989
3	24.622	24.670	52.8	0.	52.8	0.	318.9	1.000	14.17	0.993
4	23.867	23.968	52.3	0.	52.3	0.	318.6	1.000	14.17	0.994
5	22.858	23.034	53.5	0.	53.5	0.	318.5	1.000	14.17	0.993
6	21.843	22.107	55.2	0.	55.2	0.	318.6	1.000	14.17	0.993
7	21.078	21.420	58.2	0.	58.2	0.	319.2	1.000	14.17	0.986
8	20.826	21.110	60.5	0.	60.5	0.	319.9	1.000	14.17	0.969
9	20.578	20.724	63.7	0.	63.7	0.	321.0	1.000	14.17	0.928
HUB	20.320	20.320	67.2	0.	67.2	0.	322.2	1.000	14.17	0.875

RP	ABS VEL		REL VEL		MERID VEL		TANG VEL		WHEEL SPEED	
	IN	OUT	IN	OUT	IN	OUT	IN	OUT	IN	OUT
TIP	163.4	82.1	163.4	82.1	70.7	82.1	147.3	0.	0.	0.
1	162.1	91.2	162.1	91.2	83.5	91.2	138.9	-0.	0.	0.
2	162.5	97.5	162.5	97.5	93.3	97.5	133.1	-0.	0.	0.
3	164.1	101.4	164.1	101.4	99.2	101.4	130.8	0.	0.	0.
4	168.4	104.0	168.4	104.0	102.9	104.0	133.3	0.	0.	0.
5	172.7	104.2	172.7	104.2	102.8	104.2	138.8	0.	0.	0.
6	177.3	103.4	177.3	103.4	101.2	103.4	145.6	0.	0.	0.
7	181.2	87.7	181.2	87.7	95.5	87.7	154.0	0.	0.	0.
8	183.2	67.9	183.2	67.9	90.2	67.9	159.4	0.	0.	0.
9	186.1	31.7	186.1	31.7	82.6	31.7	166.8	0.	0.	0.
HUB	190.0	13.1	190.0	13.1	73.7	-13.1	175.2	-0.	0.	0.

RP	ABS MACH NO		REL MACH NO		MERID MACH NO		STREAMLINE SLOPE		MERID PEAK SS	
	IN	OUT	IN	OUT	IN	OUT	IN	OUT	VEL R	MACH NO
TIP	0.463	0.229	0.463	0.229	0.200	0.229	-0.34	-0.23	1.161	0.975
1	0.460	0.255	0.460	0.255	0.237	0.255	-0.11	0.01	1.002	0.899
2	0.463	0.274	0.463	0.274	0.266	0.274	0.07	0.19	1.045	0.852
3	0.468	0.286	0.468	0.286	0.283	0.286	0.20	0.34	1.023	0.833
4	0.481	0.293	0.481	0.293	0.294	0.293	0.42	0.69	1.011	0.841
5	0.495	0.294	0.495	0.294	0.294	0.294	0.72	1.21	1.013	0.865
6	0.508	0.291	0.508	0.291	0.290	0.291	1.06	1.85	1.022	0.895
7	0.519	0.246	0.519	0.246	0.274	0.246	1.37	2.40	0.918	0.937
8	0.525	0.190	0.525	0.190	0.259	0.190	1.18	2.18	0.753	0.969
9	0.533	0.088	0.533	0.088	0.236	0.088	0.72	1.22	0.384	1.014
HUB	0.544	0.036	0.544	0.036	0.211	-0.036	0.14	-0.19	-0.177	1.069

RP	PERCENT		INCIDENCE		DEV	D-FACT	EFF	LOSS COEFF		LOSS PARAM	
	SPAN		MEAN	SS				TOT	PROF	TOT	PROF
TIP	0.		-2.0	-6.4	16.1	0.749	0.	0.234	0.234	0.065	0.065
1	5.00		-2.0	-6.3	14.3	0.674	0.	0.134	0.134	0.037	0.037
2	10.00		-2.0	-6.3	13.0	0.624	0.	0.080	0.080	0.022	0.022
3	15.00		-2.0	-6.2	12.3	0.597	0.	0.050	0.050	0.013	0.013
4	30.00		-2.0	-5.8	12.0	0.589	0.	0.041	0.041	0.011	0.011
5	50.00		-2.0	-5.3	12.0	0.599	0.	0.043	0.043	0.011	0.011
6	70.00		-2.0	-4.9	12.2	0.614	0.	0.046	0.046	0.011	0.011
7	85.00		-2.0	-4.5	12.7	0.712	0.	0.082	0.082	0.019	0.019
8	90.00		-1.9	-4.4	13.1	0.828	0.	0.176	0.176	0.040	0.040
9	95.00		-1.9	-4.2	13.9	1.032	0.	0.401	0.401	0.091	0.091
HUB	100.00		-2.0	-4.3	14.7	1.137	0.	0.682	0.682	0.152	0.152

TABLE 8. - BLADE GEOMETRY FOR ROTOR 23B

RP	PERCENT RADII		BLADE ANGLES			DELTA		CCONE
	SPAN	RI	RO	KIC	KTC	KOC	INC	ANGLE
TIP	0.	25.400	25.400	63.54	58.04	53.62	2.26	0.057
1	5.	25.168	25.146	63.31	57.75	53.11	2.44	-0.478
2	10.	24.912	24.892	63.06	57.39	52.55	2.63	-0.425
3	15.	24.656	24.638	62.80	56.98	51.83	2.83	-0.370
4	30.	23.886	23.876	62.01	55.69	49.57	3.39	-0.198
5	50.	22.856	22.860	60.91	53.92	46.30	4.11	0.079
6	70.	21.829	21.844	59.75	52.02	42.55	4.00	0.277
7	85.	21.055	21.082	58.84	50.45	39.17	5.28	0.469
8	90.	20.797	20.828	58.53	49.86	37.83	5.44	0.532
9	95.	20.538	20.574	58.22	49.16	36.15	5.59	0.600
HUB	100.	20.320	20.320	57.95	48.52	34.34	5.72	0.057

RP	BLADE THICKNESSES			AXIAL DIMENSIONS			
	TI	TM	TO	ZIC	ZMC	ZTC	ZOC
TIP	0.051	0.151	0.051	0.336	1.557	1.695	2.935
1	0.051	0.158	0.051	0.325	1.558	1.679	2.962
2	0.051	0.167	0.051	0.313	1.559	1.662	3.001
3	0.051	0.176	0.051	0.299	1.559	1.643	3.022
4	0.051	0.201	0.051	0.255	1.559	1.584	3.090
5	0.051	0.233	0.051	0.194	1.560	1.497	3.186
6	0.051	0.264	0.051	0.126	1.560	1.400	3.290
7	0.051	0.286	0.051	0.069	1.560	1.319	3.377
8	0.051	0.293	0.051	0.048	1.559	1.289	3.411
9	0.051	0.300	0.051	0.023	1.558	1.255	3.450
HUB	0.051	0.306	0.051	-0.000	1.557	1.226	3.492

RP	AERO SETTING			TOTAL SOLIDITY	X		AREA
	CHORD	ANGLE	CAMBER		FACTOR	PHISS	RATIO
TIP	5.092	58.57	9.92	1.595	1.000	7.99	1.102
1	5.094	58.21	10.20	1.611	1.000	8.21	1.103
2	5.094	57.80	10.53	1.628	1.000	8.49	1.106
3	5.094	57.32	10.97	1.645	1.000	8.81	1.109
4	5.094	55.79	12.44	1.698	1.000	9.75	1.116
5	5.094	53.61	14.61	1.773	1.000	10.90	1.126
6	5.094	51.15	17.21	1.856	1.000	11.99	1.136
7	5.094	49.01	19.67	1.924	1.000	12.83	1.146
8	5.094	48.18	20.71	1.948	1.000	13.15	1.150
9	5.094	47.18	22.07	1.972	1.000	13.57	1.156
HUB	5.095	46.20	23.61	1.995	1.000	13.96	1.161

TABLE 9. - BLADE GEOMETRY FOR ROTOR 24A

RP	PERCENT		RADII		BLADE ANGLES			DELTA	CONE
	SPAN	RI	RO	KIC	KTC	KOC	INC	ANGLE	
TIP	0.	25.400	25.400	63.11	57.98	53.82	2.69	0.057	
1	5.	25.168	25.146	62.88	57.69	53.30	2.87	-0.319	
2	10.	24.911	24.892	62.62	57.32	52.71	3.07	-0.280	
3	15.	24.655	24.638	62.36	56.90	52.01	3.26	-0.243	
4	30.	23.886	23.876	61.56	55.59	49.74	3.84	-0.134	
5	50.	22.854	22.860	60.46	53.80	46.46	4.57	0.071	
6	70.	21.829	21.844	59.28	51.89	42.71	5.26	0.186	
7	85.	21.055	21.082	58.36	50.31	39.34	5.76	0.314	
8	90.	20.797	20.828	58.05	49.71	38.00	5.92	0.359	
9	95.	20.538	20.574	57.73	49.01	36.32	6.07	0.402	
HUB	100.	20.320	20.320	57.46	48.37	34.52	6.20	0.057	

RP	BLADE THICKNESSES			AXIAL DIMENSIONS			
	TI	TM	TO	ZIC	ZMC	ZTC	ZOC
TIP	0.051	0.226	0.051	0.515	2.332	2.524	4.407
1	0.051	0.238	0.051	0.498	2.332	2.500	4.431
2	0.051	0.251	0.051	0.478	2.332	2.472	4.458
3	0.051	0.263	0.051	0.457	2.331	2.443	4.489
4	0.051	0.301	0.051	0.389	2.330	2.355	4.587
5	0.051	0.350	0.051	0.294	2.326	2.220	4.724
6	0.051	0.396	0.051	0.192	2.324	2.073	4.874
7	0.051	0.429	0.051	0.105	2.320	1.950	5.001
8	0.051	0.440	0.051	0.073	2.318	1.904	5.049
9	0.051	0.451	0.051	0.034	2.315	1.853	5.106
HUB	0.051	0.460	0.051	-0.000	2.312	1.808	5.166

RP	AERO	SETTING	TOTAL	SOLIDITY	X	PHISS	AREA
	CHORD	ANGLE	CAMBER		FACTOR		RATIO
TIP	7.489	58.45	9.29	1.596	1.000	8.07	1.115
1	7.491	58.09	9.57	1.611	1.000	8.29	1.118
2	7.491	57.67	9.91	1.628	1.000	8.57	1.121
3	7.492	57.19	10.35	1.645	1.000	8.89	1.124
4	7.492	55.65	11.82	1.698	1.000	9.85	1.130
5	7.491	53.46	13.99	1.773	1.000	10.98	1.140
6	7.491	51.00	16.57	1.856	1.000	12.04	1.151
7	7.491	48.85	19.02	1.924	1.000	12.87	1.161
8	7.491	48.02	20.05	1.948	1.000	13.19	1.165
9	7.491	47.03	21.41	1.972	1.000	13.60	1.171
HUB	7.493	46.04	22.95	1.996	1.000	13.98	1.176

TABLE 10. - BLADE GEOMETRY FOR ROTOR 25A

RP	PERCENT		RADII		BLADE ANGLES			DELTA	CONE
	SPAN	RI	RO	KIC	KTC	KOC	INC	ANGLE	
TIP	0.	25.400	25.400	64.62	56.28	53.40	1.15	0.057	
1	5.	25.167	25.146	64.39	56.05	53.01	1.34	-0.958	
2	10.	24.911	24.892	64.14	55.75	52.54	1.54	-0.850	
3	15.	24.655	24.638	63.88	55.37	51.95	1.74	-0.741	
4	30.	23.885	23.876	63.07	54.11	49.96	2.35	-0.399	
5	50.	22.857	22.860	61.95	52.31	46.98	3.08	0.114	
6	70.	21.829	21.844	60.75	50.34	43.49	3.79	0.559	
7	85.	21.057	21.082	59.80	48.67	40.34	4.30	0.935	
8	90.	20.798	20.828	59.47	48.04	39.11	4.47	1.069	
9	95.	20.540	20.574	59.14	47.29	37.61	4.63	1.202	
HUB	100.	20.320	20.320	58.86	46.62	36.02	4.76	0.057	

RP	BLADE THICKNESSES			AXIAL DIMENSIONS			
	TI	TM	TO	ZIC	ZMC	ZTC	ZOC
TIP	0.051	0.075	0.051	0.115	0.689	1.003	1.365
1	0.051	0.079	0.051	0.112	0.692	0.997	1.374
2	0.051	0.084	0.051	0.109	0.694	0.989	1.384
3	0.051	0.088	0.051	0.105	0.696	0.982	1.395
4	0.051	0.100	0.051	0.091	0.703	0.958	1.432
5	0.051	0.117	0.051	0.072	0.713	0.922	1.484
6	0.051	0.132	0.051	0.047	0.720	0.878	1.539
7	0.051	0.143	0.051	0.026	0.726	0.841	1.585
8	0.051	0.147	0.051	0.018	0.728	0.827	1.602
9	0.051	0.150	0.051	0.008	0.730	0.813	1.622
HUB	0.051	0.153	0.051	-0.000	0.731	0.800	1.643

RP	AERO	SETTING	TOTAL	X	FACTOR	PHISS	AREA
	CHORD	ANGLE	CAMBER				
TIP	2.479	59.00	11.22	1.196	1.000	10.04	1.114
1	2.481	58.70	11.39	1.209	1.000	10.29	1.117
2	2.481	58.34	11.60	1.221	1.000	10.60	1.120
3	2.481	57.92	11.92	1.234	1.000	10.97	1.123
4	2.481	56.52	13.11	1.273	1.000	12.12	1.132
5	2.481	54.46	14.97	1.330	1.000	13.56	1.144
6	2.481	52.12	17.26	1.392	1.000	14.92	1.156
7	2.481	50.07	19.46	1.443	1.000	15.98	1.167
8	2.481	49.29	20.37	1.461	1.000	16.37	1.172
9	2.481	48.38	21.53	1.479	1.000	16.85	1.178
HUB	2.482	47.49	22.84	1.497	1.000	17.29	1.183

TABLE 11. - BLADE GEOMETRY FOR ROTOR 26B

RP	PERCENT SPAN	RADII		BLADE ANGLES			DELTA INC.	CONE ANGLE
		R1	RO	K1C	KTC	KOC		
TIP	0.	25.400	25.400	64.09	56.86	49.41	2.05	0.057
1	5.	25.176	25.146	63.76	56.43	48.59	2.22	-0.747
2	10.	24.926	24.892	63.41	55.94	47.71	2.41	-0.036
3	15.	24.672	24.638	63.08	55.41	46.73	2.60	-0.814
4	30.	23.895	23.876	62.19	53.94	45.79	3.17	-0.427
5	50.	22.851	22.860	61.08	51.97	39.45	3.90	0.136
6	70.	21.807	21.844	59.94	49.65	34.32	4.59	0.758
7	85.	21.028	21.082	59.09	48.12	29.64	5.06	1.038
8	90.	20.774	20.828	58.82	47.42	27.61	5.21	1.017
9	95.	20.526	20.574	58.54	46.55	25.01	5.34	0.885
HUB	100.	20.320	20.320	58.31	45.77	22.18	5.45	0.057

RP	BLADE THICKNESSES			AXIAL DIMENSIONS			
	TI	TM	TO	Z1C	ZMC	ZTC	ZCC
TIP	0.051	0.126	0.051	0.339	1.369	1.345	2.022
1	0.051	0.132	0.051	0.326	1.370	1.331	2.643
2	0.051	0.139	0.051	0.312	1.371	1.315	2.666
3	0.051	0.146	0.051	0.297	1.371	1.298	2.680
4	0.051	0.167	0.051	0.254	1.373	1.244	2.759
5	0.051	0.194	0.051	0.195	1.374	1.166	2.856
6	0.051	0.220	0.051	0.129	1.374	1.078	2.931
7	0.051	0.239	0.051	0.074	1.373	1.003	3.050
8	0.051	0.245	0.051	0.052	1.373	0.974	3.085
9	0.051	0.251	0.051	0.024	1.372	0.941	3.129
HUB	0.051	0.255	0.051	-0.000	1.372	0.911	3.175

RP	AERO CHORD	SETTING		TOTAL SOLIDITY	X FACTOR	PHISS	AREA RATIO
		ANGLE	CAMBER				
TIP	4.212	56.73	14.68	1.795	1.000	9.21	1.121
1	4.214	56.18	15.17	1.813	1.000	9.45	1.120
2	4.214	55.56	15.70	1.831	1.000	9.74	1.119
3	4.214	54.91	16.34	1.850	1.000	10.08	1.119
4	4.214	52.99	18.41	1.909	1.000	11.06	1.121
5	4.214	50.26	21.63	1.995	1.000	12.34	1.132
6	4.214	47.13	25.62	2.090	1.000	13.61	1.146
7	4.214	44.37	29.46	2.166	1.000	14.64	1.162
8	4.214	43.22	31.21	2.192	1.000	15.06	1.171
9	4.214	41.78	33.54	2.219	1.000	15.67	1.182
HUB	4.215	40.31	36.13	2.245	1.000	16.21	1.192

TABLE 12. - BLADE GEOMETRY FOR ROTOR 27A

RP	PERCENT RADII		BLADE ANGLES			DELTA	CONE	
	SPAN	RI	RO	KIC	KTC	KOC	INC	ANGLE
TIP	0.	25.400	25.400	63.52	56.76	49.69	2.61	0.057
1	5.	25.177	25.146	63.19	56.32	48.85	2.73	-0.446
2	10.	24.927	24.892	62.85	55.81	47.95	2.96	-0.501
3	15.	24.673	24.638	62.52	55.28	46.95	3.15	-0.491
4	30.	23.895	23.876	61.64	53.78	43.96	3.72	-0.259
5	50.	22.852	22.860	60.54	51.80	39.60	4.45	0.107
6	70.	21.806	21.844	59.40	49.68	34.47	5.13	0.451
7	85.	21.027	21.082	58.57	47.95	29.81	5.60	0.621
8	90.	20.773	20.828	58.29	47.75	27.79	5.74	0.606
9	95.	20.525	20.574	58.02	46.39	25.19	5.87	0.525
HUB	100.	20.320	20.320	57.79	45.61	22.37	5.98	0.057

RP	BLADE THICKNESSES			AXIAL DIMENSIONS			
	TI	TM	TO	ZIC	ZMC	ZTC	ZOC
TIP	0.051	0.213	0.051	0.609	2.388	2.330	4.524
1	0.051	0.224	0.051	0.586	2.388	2.305	4.560
2	0.051	0.236	0.051	0.559	2.388	2.276	4.598
3	0.051	0.248	0.051	0.532	2.387	2.245	4.638
4	0.051	0.284	0.051	0.453	2.384	2.148	4.754
5	0.051	0.330	0.051	0.348	2.381	2.009	4.914
6	0.051	0.375	0.051	0.229	2.374	1.849	5.086
7	0.051	0.406	0.051	0.131	2.368	1.716	5.231
8	0.051	0.416	0.051	0.092	2.366	1.665	5.289
9	0.051	0.426	0.051	0.044	2.362	1.606	5.361
HUB	0.051	0.434	0.051	-0.000	2.359	1.554	5.438

RP	AERO SETTING TOTAL			X SOLIDITY	FACTOR	PHISS	AREA RATIO
	CHORD	ANGLE	CAMBER				
TIP	7.161	56.58	13.82	1.795	1.000	9.27	1.145
1	7.164	56.02	14.34	1.813	1.000	9.51	1.144
2	7.164	55.40	14.90	1.831	1.000	9.81	1.145
3	7.164	54.74	15.56	1.850	1.000	10.15	1.143
4	7.164	52.80	17.69	1.909	1.000	11.14	1.145
5	7.164	50.07	20.94	1.995	1.000	12.40	1.156
6	7.164	46.94	24.94	2.090	1.000	13.65	1.171
7	7.164	44.19	28.76	2.166	1.000	14.65	1.188
8	7.163	43.04	30.50	2.192	1.000	15.08	1.197
9	7.163	41.61	32.82	2.219	1.000	15.65	1.208
HUB	7.165	40.15	35.41	2.245	1.000	16.18	1.218

TABLE 13. - BLADE GEOMETRY FOR ROTOR 28B

RP	PERCENT RADII			BLADE ANGLES			DELTA INC	CONE ANGLE
	SPAN	RI	RO	KIC	KTC	KOC		
TIP	0.	25.400	25.400	64.08	54.88	45.13	2.47	0.057
1	5.	25.191	25.146	63.64	54.10	43.52	2.63	-0.606
2	10.	24.952	24.892	63.17	53.28	41.95	2.80	-0.901
3	15.	24.701	24.638	62.75	52.52	40.44	2.99	-0.920
4	30.	23.905	23.876	61.79	50.77	36.53	3.56	-0.401
5	50.	22.831	22.860	60.68	48.52	30.86	4.23	0.375
6	70.	21.757	21.844	59.54	46.14	24.17	4.95	1.054
7	85.	20.971	21.082	58.68	44.18	18.04	5.39	1.282
8	90.	20.730	20.828	58.38	43.17	14.75	5.50	1.112
9	95.	20.503	20.574	58.08	41.90	10.38	5.59	0.775
HUB	100.	20.320	20.320	57.82	40.76	5.60	5.66	0.057

RP	BLADE THICKNESSES			AXIAL DIMENSIONS			
	TI	TM	TO	ZIC	ZMC	ZTC	ZCC
TIP	0.051	0.188	0.051	0.702	2.319	2.253	4.362
1	0.051	0.197	0.051	0.669	2.320	2.224	4.419
2	0.051	0.207	0.051	0.634	2.320	2.191	4.473
3	0.051	0.217	0.051	0.599	2.320	2.157	4.525
4	0.051	0.250	0.051	0.515	2.316	2.055	4.645
5	0.051	0.292	0.051	0.402	2.309	1.909	4.808
6	0.051	0.332	0.051	0.279	2.303	1.744	4.983
7	0.051	0.360	0.051	0.172	2.297	1.603	5.125
8	0.051	0.369	0.051	0.120	2.296	1.541	5.192
9	0.051	0.377	0.051	0.057	2.295	1.468	5.278
HUB	0.051	0.383	0.051	-0.000	2.294	1.404	5.370

RP	AERO SETTING TOTAL			SOLIDITY	X FACTOR	PHISS	AREA RATIO
	CHORD	ANGLE	CAMBER				
TIP	6.365	54.57	18.95	1.795	1.000	11.56	1.204
1	6.368	53.58	20.12	1.812	1.000	11.99	1.199
2	6.368	52.56	21.22	1.830	1.000	12.47	1.193
3	6.368	51.59	22.31	1.849	1.000	12.92	1.188
4	6.368	49.16	25.26	1.909	1.000	14.06	1.185
5	6.367	45.77	29.82	1.996	1.000	15.55	1.198
6	6.368	41.86	35.37	2.092	1.000	17.00	1.217
7	6.368	38.36	40.64	2.169	1.000	18.15	1.244
8	6.366	36.56	43.63	2.194	1.000	18.82	1.259
9	6.365	34.22	47.70	2.220	1.000	19.71	1.277
HUB	6.369	31.80	52.22	2.245	1.000	20.52	1.293

TABLE 14. - BLADE GEOMETRY FOR STATOR 20

RP	PERCENT RADII			BLADE ANGLES			DELTA	CONE
	SPAN	RI	RO	KIC	KTC	KOC	INC	ANGLE
TIP	0.	25.400	25.400	44.75	25.31	-10.67	4.54	0.057
1	5.	25.133	25.109	42.84	24.92	-10.04	4.43	-0.299
2	10.	24.881	24.859	41.49	24.68	-9.62	4.32	-0.205
3	15.	24.628	24.610	40.84	24.63	-9.39	4.20	-0.230
4	30.	23.871	23.861	41.01	25.13	-9.26	3.65	-0.126
5	50.	22.858	22.863	42.05	26.12	-9.30	3.34	0.067
6	70.	21.850	21.864	43.44	27.28	-9.40	2.58	0.176
7	85.	21.092	21.116	45.42	28.56	-9.69	2.53	0.294
8	90.	20.839	20.866	46.53	29.16	-9.90	2.42	0.554
9	95.	20.586	20.616	48.07	29.93	-10.21	2.30	0.374
HUB	100.	20.320	20.320	49.87	30.82	-10.62	2.18	0.057

RP	BLADE THICKNESSES			AXIAL DIMENSIONS			
	TI	TM	TO	ZIC	ZMC	ZTC	ZOC
TIP	0.051	0.256	0.051	5.633	7.772	7.076	10.261
1	0.051	0.250	0.051	5.615	7.775	7.019	10.257
2	0.051	0.244	0.051	5.601	7.777	6.976	10.255
3	0.051	0.238	0.051	5.595	7.778	6.948	10.254
4	0.051	0.222	0.051	5.598	7.778	6.917	10.254
5	0.051	0.200	0.051	5.609	7.775	6.891	10.252
6	0.051	0.180	0.051	5.625	7.772	6.871	10.252
7	0.051	0.165	0.051	5.646	7.767	6.872	10.253
8	0.051	0.160	0.051	5.659	7.765	6.880	10.254
9	0.051	0.155	0.051	5.677	7.762	6.894	10.255
HUB	0.051	0.150	0.051	5.698	7.757	6.911	10.256

RP	AERO SETTING			TOTAL SOLIDITY	X FACTOR	PHISS	AREA RATIO
	CHORD	ANGLE	CAMBER				
TIP	4.891	17.06	55.42	1.594	1.000	22.34	1.792
1	4.890	16.39	52.87	1.611	1.000	20.66	1.753
2	4.891	15.94	51.11	1.627	1.000	19.43	1.750
3	4.891	15.73	50.23	1.644	1.000	18.71	1.713
4	4.891	15.87	50.28	1.696	1.000	18.11	1.690
5	4.891	16.38	51.35	1.771	1.000	17.83	1.672
6	4.891	17.02	52.84	1.852	1.000	17.75	1.656
7	4.890	17.86	55.12	1.918	1.000	18.26	1.655
8	4.890	18.31	56.44	1.941	1.000	18.70	1.660
9	4.890	18.92	58.28	1.965	1.000	19.41	1.668
HUB	4.891	19.63	60.49	1.992	1.000	20.26	1.678

TABLE 15. - BLADE GEOMETRY FOR STATOR 20B

RP	PERCENT RADII		BLADE ANGLES			DELTA	CONE	
	SPAN	RI	RO	KIC	KTC	KOC	INC	ANGLE
TIP	0.	25.400	25.400	44.73	25.30	-10.67	4.53	0.057
1	5.	25.136	25.105	42.83	24.92	-10.04	4.42	-0.392
2	10.	24.884	24.855	41.49	24.68	-9.62	4.32	-0.347
3	15.	24.631	24.606	40.84	24.63	-9.39	4.20	-0.302
4	30.	23.872	23.859	41.01	25.13	-9.26	3.83	-0.160
5	50.	22.858	22.866	42.05	26.12	-9.30	3.34	0.091
6	70.	21.848	21.867	43.44	27.28	-9.40	2.88	0.227
7	85.	21.089	21.120	45.42	28.56	-9.69	2.53	0.383
8	90.	20.836	20.871	46.53	29.16	-9.90	2.42	0.436
9	95.	20.583	20.622	48.06	29.93	-10.21	2.31	0.491
HUB	100.	20.320	20.320	49.83	30.80	-10.63	2.19	0.057

RP	BLADE THICKNESSES			AXIAL DIMENSIONS			
	TI	TM	TO	ZIC	ZMC	ZTC	ZOC
TIP	0.051	0.256	0.051	3.706	5.845	5.147	8.333
1	0.051	0.250	0.051	3.687	5.848	5.091	8.330
2	0.051	0.244	0.051	3.674	5.850	5.048	8.328
3	0.051	0.238	0.051	3.667	5.851	5.021	8.326
4	0.051	0.222	0.051	3.671	5.851	4.990	8.326
5	0.051	0.200	0.051	3.681	5.847	4.963	8.325
6	0.051	0.180	0.051	3.697	5.845	4.943	8.325
7	0.051	0.165	0.051	3.719	5.840	4.944	8.325
8	0.051	0.160	0.051	3.732	5.838	4.952	8.326
9	0.051	0.155	0.051	3.749	5.834	4.966	8.327
HUB	0.051	0.150	0.051	3.770	5.830	4.983	8.329

RP	AERO	SETTING	TOTAL	SOLIDITY	X	FACTOR	PHISS	AREA
	CHORD	ANGLE	CAMBER					RATIO
TIP	4.891	17.05	55.40	1.226	1.000	22.51	1.791	
1	4.890	16.39	52.87	1.239	1.000	20.66	1.753	
2	4.891	15.93	51.11	1.252	1.000	19.43	1.730	
3	4.891	15.73	50.22	1.265	1.000	18.71	1.713	
4	4.891	15.87	50.28	1.305	1.000	18.11	1.690	
5	4.891	16.38	51.35	1.362	1.000	17.83	1.672	
6	4.891	17.02	52.83	1.424	1.000	17.75	1.656	
7	4.891	17.86	55.12	1.475	1.000	18.26	1.655	
8	4.890	18.31	56.43	1.493	1.000	18.70	1.660	
9	4.890	18.92	58.27	1.511	1.000	19.40	1.668	
HUB	4.891	19.61	60.46	1.532	1.000	20.24	1.677	

TABLE 16. - BLADE GEOMETRY FOR STATOR 21

RP	PERCENT		RADI!		BLADE ANGLES			DELTA	CONE
	SPAN	RI	RO	KIC	KTC	KOC	INC	ANGLE	
TIP	0.	25.400	25.400	55.65	30.61	-12.89	4.14	0.057	
1	5.	25.132	25.113	52.43	29.85	-11.86	4.07	-0.292	
2	10.	24.878	24.867	50.10	29.34	-11.17	3.93	-0.165	
3	15.	24.625	24.622	48.86	29.14	-10.77	3.88	-0.057	
4	30.	23.870	23.877	48.60	29.59	-10.52	3.52	0.102	
5	50.	22.862	22.883	49.66	30.71	-10.53	3.04	0.318	
6	70.	21.851	21.888	51.16	32.07	-10.63	2.58	0.559	
7	85.	21.092	21.137	53.65	33.68	-11.02	2.24	0.686	
8	90.	20.838	20.882	55.23	34.53	-11.33	2.13	0.663	
9	95.	20.585	20.622	57.42	35.65	-11.80	2.02	0.564	
HUB	100.	20.320	20.320	59.97	36.92	-12.40	1.90	0.057	

RP	BLADE THICKNESSES			AXIAL DIMENSIONS			
	TI	TM	TO	ZIC	ZMC	ZTC	ZOC
TIP	0.051	0.212	0.051	7.507	9.160	8.645	11.265
1	0.051	0.208	0.051	7.475	9.165	8.591	11.260
2	0.051	0.203	0.051	7.451	9.169	8.548	11.257
3	0.051	0.198	0.051	7.438	9.171	8.520	11.254
4	0.051	0.184	0.051	7.440	9.174	8.489	11.255
5	0.051	0.166	0.051	7.450	9.170	8.462	11.253
6	0.051	0.149	0.051	7.466	9.166	8.441	11.253
7	0.051	0.137	0.051	7.493	9.160	8.439	11.253
8	0.051	0.133	0.051	7.511	9.157	8.446	11.254
9	0.051	0.129	0.051	7.535	9.151	8.457	11.255
HUB	0.051	0.125	0.051	7.563	9.144	8.471	11.256

RP	AERO SETTING			TOTAL SOLIDITY	X FACTOR	PHISS	AREA RAT:10
	CHORD	ANGLE	CAMBER				
TIP	4.088	21.42	68.54	1.793	1.000	27.64	1.747
1	4.086	20.27	64.30	1.812	1.000	25.06	1.688
2	4.087	19.46	61.27	1.831	1.000	23.14	1.644
3	4.088	19.06	59.63	1.849	1.000	21.99	1.615
4	4.087	19.04	59.12	1.907	1.000	21.02	1.585
5	4.087	19.56	60.18	1.991	1.000	20.62	1.564
6	4.087	20.26	61.78	2.082	1.000	20.47	1.548
7	4.087	21.31	64.67	2.157	1.000	21.14	1.558
8	4.087	21.94	66.56	2.183	1.000	21.80	1.574
9	4.087	22.80	69.22	2.210	1.000	22.82	1.598
HUB	4.088	23.81	72.37	2.241	1.000	24.02	1.625

TABLE 17. - BLADE GEOMETRY FOR STATOR 22

RP	PERCENT RADII		BLADE ANGLES			DELTA	CONE	
	SPAN	R1	R0	KIC	KTC	KOC	INC	ANGLE
TIP	0.	25.400	25.400	66.41	33.55	-16.09	4.32	0.057
1	5.	25.131	25.128	60.99	32.34	-14.27	4.31	-0.057
2	10.	24.875	24.901	57.00	31.49	-13.04	4.27	0.258
3	15.	24.622	24.670	54.84	31.11	-12.34	4.19	0.483
4	30.	23.867	23.968	54.32	31.56	-12.02	3.83	1.006
5	50.	22.858	23.034	55.45	32.80	-12.03	3.35	1.757
6	70.	21.843	22.107	57.16	34.32	-12.17	2.89	2.654
7	85.	21.078	21.420	60.13	36.16	-12.70	2.55	3.468
8	90.	20.826	21.110	62.40	37.32	-13.14	2.44	2.903
9	95.	20.578	20.724	65.57	38.88	-13.86	2.32	1.503
HUB	100.	20.320	20.320	69.22	40.66	-14.72	2.21	0.057

RP	BLADE THICKNESSES			AXIAL DIMENSIONS			
	T1	TM	TO	ZIC	ZMC	ZTC	ZOC
TIP	0.051	0.320	0.051	7.490	9.788	9.203	13.072
1	0.051	0.313	0.051	7.393	9.805	9.100	13.055
2	0.051	0.307	0.051	7.323	9.818	9.021	13.043
3	0.051	0.300	0.051	7.287	9.826	8.969	13.037
4	0.051	0.278	0.051	7.280	9.825	8.909	13.034
5	0.051	0.250	0.051	7.303	9.823	8.869	13.034
6	0.051	0.223	0.051	7.337	9.818	8.836	13.036
7	0.051	0.204	0.051	7.392	9.807	8.832	13.038
8	0.051	0.199	0.051	7.433	9.796	8.839	13.040
9	0.051	0.193	0.051	7.491	9.780	8.852	13.042
HUB	0.051	0.188	0.051	7.557	9.760	8.867	13.044

RP	AERO SETTING			TOTAL SOLIDITY	X FACTOR	PHISS	AREA RATIO
	CHORD	ANGLE	CAMBER				
TIP	6.224	25.26	82.50	1.794	1.000	35.65	1.837
1	6.215	23.30	75.25	1.811	1.000	31.38	1.703
2	6.218	21.96	70.04	1.829	1.000	28.17	1.603
3	6.222	21.28	67.18	1.848	1.000	26.31	1.546
4	6.220	21.15	66.34	1.904	1.000	25.06	1.512
5	6.222	21.71	67.48	1.985	1.000	24.60	1.494
6	6.225	22.50	69.33	2.074	1.000	24.46	1.484
7	6.229	23.72	72.83	2.146	1.000	25.38	1.552
8	6.225	24.60	75.54	2.173	1.000	26.40	1.619
9	6.220	25.82	79.43	2.205	1.000	27.93	1.709
HUB	6.224	27.27	83.94	2.242	1.000	29.72	1.813

TABLE 18. - STATIC ROTOR TIP CLEARANCES

Rotor	Clearance, cm		
	Maximum	Minimum	Arithmetic average
23B	0.048	0.023	0.036
23D	.048	.048	.039
24A	.061	.048	.055
24B	.066	.043	.055
25A	.048	.033	.042
26B	.064	.030	.051
26D	↓	.041	.051
27A	↓	.041	.053
27C	↓	.033	.048
27D	.069	.051	.056
28B	.056	.038	.047
28D	.061	.028	.045

TABLE 19. - OVERALL PERFORMANCE OF STAGE 23B-20

(a) 120 Percent of design speed

READING NUMBER	3747	3722	3721	3748	3723
ROTOR TOTAL PRESSURE RATIO	1.280	1.332	1.391	1.436	1.458
STATOR TOTAL PRESSURE RATIO	0.988	0.987	0.979	0.969	0.961
ROTOR TOTAL TEMPERATURE RATIO	1.089	1.098	1.107	1.119	1.127
STATOR TOTAL TEMPERATURE RATIO	0.999	0.999	0.998	0.997	0.997
ROTOR ADIABATIC EFFICIENCY	0.818	0.876	0.921	0.917	0.895
ROTOR MOMENTUM-RISE EFFICIENCY	0.824	0.876	0.932	0.948	0.928
ROTOR HEAD-RISE COEFFICIENT	0.270	0.318	0.371	0.413	0.435
FLOW COEFFICIENT	0.513	0.512	0.492	0.453	0.413
AIRFLOW PER UNIT FRONTAL AREA	57.34	57.15	55.34	51.81	47.66
AIRFLOW PER UNIT ANNULUS AREA	159.27	158.75	153.72	143.92	132.40
AIRFLOW AT ORIFICE	11.62	11.58	11.22	10.50	9.66
AIRFLOW AT ROTOR INLET	11.91	11.89	11.52	10.77	9.92
AIRFLOW AT ROTOR OUTLET	11.75	11.70	11.47	10.94	10.01
AIRFLOW AT STATOR OUTLET	11.69	11.67	11.22	10.35	9.38
ROTATIVE SPEED	10985.4	10984.1	10993.2	10996.7	10981.4
PERCENT OF DESIGN SPEED	119.8	119.8	119.9	119.9	119.8

COMPRESSOR PERFORMANCE

STAGE TOTAL PRESSURE RATIO	1.266	1.315	1.362	1.392	1.401
STAGE TOTAL TEMPERATURE RATIO	1.088	1.096	1.105	1.115	1.124
STAGE ADIABATIC EFFICIENCY	0.793	0.844	0.882	0.861	0.818

(b) 110 Percent of design speed

READING NUMBER	3720	3716	3719
ROTOR TOTAL PRESSURE RATIO	1.209	1.305	1.359
STATOR TOTAL PRESSURE RATIO	0.991	0.986	0.971
ROTOR TOTAL TEMPERATURE RATIO	1.069	1.086	1.102
STATOR TOTAL TEMPERATURE RATIO	1.000	0.999	0.997
ROTOR ADIABATIC EFFICIENCY	0.805	0.917	0.898
ROTOR MOMENTUM-RISE EFFICIENCY	0.810	0.933	0.932
ROTOR HEAD-RISE COEFFICIENT	0.241	0.345	0.407
FLOW COEFFICIENT	0.525	0.487	0.416
AIRFLOW PER UNIT FRONTAL AREA	54.43	51.08	44.51
AIRFLOW PER UNIT ANNULUS AREA	151.20	141.88	123.65
AIRFLOW AT ORIFICE	11.03	10.35	9.02
AIRFLOW AT ROTOR INLET	11.31	10.65	9.28
AIRFLOW AT ROTOR OUTLET	11.19	10.54	9.39
AIRFLOW AT STATOR OUTLET	11.13	10.40	8.78
ROTATIVE SPEED	10069.7	10098.9	10084.5
PERCENT OF DESIGN SPEED	109.8	110.1	110.0

COMPRESSOR PERFORMANCE

STAGE TOTAL PRESSURE RATIO	1.199	1.287	1.320
STAGE TOTAL TEMPERATURE RATIO	1.069	1.085	1.099
STAGE ADIABATIC EFFICIENCY	0.769	0.881	0.834

(c) 100 Percent of design speed

READING NUMBER	3711	3712	3713	3714	3715
ROTOR TOTAL PRESSURE RATIO	1.180	1.218	1.241	1.266	1.285
STATOR TOTAL PRESSURE RATIO	0.993	0.992	0.989	0.984	0.977
ROTOR TOTAL TEMPERATURE RATIO	1.056	1.064	1.069	1.076	1.083
STATOR TOTAL TEMPERATURE RATIO	1.001	1.000	0.999	0.998	0.998
ROTOR ADIABATIC EFFICIENCY	0.861	0.905	0.916	0.912	0.891
ROTOR MOMENTUM-RISE EFFICIENCY	0.853	0.915	0.936	0.937	0.925
ROTOR HEAD-RISE COEFFICIENT	0.248	0.301	0.332	0.367	0.394
FLOW COEFFICIENT	0.538	0.510	0.481	0.446	0.401
AIRFLOW PER UNIT FRONTAL AREA	51.36	48.90	46.36	43.26	39.33
AIRFLOW PER UNIT ANNULUS AREA	142.68	135.83	128.79	120.17	109.25
AIRFLOW AT ORIFICE	10.41	9.91	9.40	8.77	7.97
AIRFLOW AT ROTOR INLET	10.69	10.19	9.67	9.04	8.22
AIRFLOW AT ROTOR OUTLET	10.51	10.03	9.57	9.02	8.25
AIRFLOW AT STATOR OUTLET	10.48	9.98	9.44	8.79	7.84
ROTATIVE SPEED	9169.7	9158.2	9148.2	9145.2	9140.6
PERCENT OF DESIGN SPEED	100.0	99.9	99.8	99.7	99.7

COMPRESSOR PERFORMANCE

STAGE TOTAL PRESSURE RATIO	1.171	1.208	1.227	1.245	1.255
STAGE TOTAL TEMPERATURE RATIO	1.057	1.064	1.068	1.074	1.081
STAGE ADIABATIC EFFICIENCY	0.810	0.872	0.882	0.868	0.824

TABLE 19. - Continued.

(d) 90 Percent of design speed

READING NUMBER	3730	3729	3728	3727	3726
ROTOR TOTAL PRESSURE RATIO	1.121	1.163	1.163	1.186	1.230
STATOR TOTAL PRESSURE RATIO	0.992	0.993	0.992	0.990	0.980
ROTOR TOTAL TEMPERATURE RATIO	1.040	1.049	1.055	1.061	1.069
STATOR TOTAL TEMPERATURE RATIO	1.002	1.000	1.000	0.999	0.999
ROTOR ADIABATIC EFFICIENCY	0.831	0.909	0.917	0.912	0.886
ROTOR MOMENTUM-RISE EFFICIENCY	0.798	0.887	0.911	0.922	0.911
ROTOR HEAD-RISE COEFFICIENT	0.207	0.277	0.317	0.352	0.389
FLOW COEFFICIENT	0.557	0.519	0.480	0.441	0.392
AIRFLOW PER UNIT FRONTAL AREA	48.23	45.40	42.17	39.22	35.02
AIRFLOW PER UNIT ANNULUS AREA	133.98	126.12	117.14	108.95	97.29
AIRFLOW AT ORIFICE	9.78	9.20	8.55	7.95	7.10
AIRFLOW AT ROTOR INLET	10.06	9.47	8.82	8.20	7.33
AIRFLOW AT ROTOR OUTLET	9.79	9.28	8.62	7.99	7.24
AIRFLOW AT STATOR OUTLET	9.80	9.28	8.64	8.06	7.02
ROTATIVE SPEED	8265.2	8273.3	8258.9	8299.2	8282.5
PERCENT OF DESIGN SPEED	90.1	90.2	90.1	90.5	90.3
COMPRESSOR PERFORMANCE					
STAGE TOTAL PRESSURE RATIO	1.112	1.155	1.177	1.197	1.206
STAGE TOTAL TEMPERATURE RATIO	1.042	1.049	1.054	1.061	1.067
STAGE ADIABATIC EFFICIENCY	0.742	0.859	0.877	0.870	0.816

(e) 80 Percent of design speed

READING NUMBER	3732
ROTOR TOTAL PRESSURE RATIO	1.178
STATOR TOTAL PRESSURE RATIO	0.984
ROTOR TOTAL TEMPERATURE RATIO	1.054
STATOR TOTAL TEMPERATURE RATIO	0.999
ROTOR ADIABATIC EFFICIENCY	0.891
ROTOR MOMENTUM-RISE EFFICIENCY	0.912
ROTOR HEAD-RISE COEFFICIENT	0.383
FLOW COEFFICIENT	0.385
AIRFLOW PER UNIT FRONTAL AREA	30.74
AIRFLOW PER UNIT ANNULUS AREA	85.40
AIRFLOW AT ORIFICE	6.23
AIRFLOW AT ROTOR INLET	6.44
AIRFLOW AT ROTOR OUTLET	6.38
AIRFLOW AT STATOR OUTLET	6.19
ROTATIVE SPEED	7345.3
PERCENT OF DESIGN SPEED	80.1
COMPRESSOR PERFORMANCE	
STAGE TOTAL PRESSURE RATIO	1.159
STAGE TOTAL TEMPERATURE RATIO	1.053
STAGE ADIABATIC EFFICIENCY	0.812

(f) 70 Percent of design speed

READING NUMBER	3737	3738	3739	3741
ROTOR TOTAL PRESSURE RATIO	1.063	1.085	1.103	1.134
STATOR TOTAL PRESSURE RATIO	0.990	0.995	0.995	0.988
ROTOR TOTAL TEMPERATURE RATIO	1.021	1.026	1.031	1.041
STATOR TOTAL TEMPERATURE RATIO	1.002	1.001	1.000	1.000
ROTOR ADIABATIC EFFICIENCY	0.837	0.898	0.914	0.895
ROTOR MOMENTUM-RISE EFFICIENCY	0.791	0.869	0.906	0.908
ROTOR HEAD-RISE COEFFICIENT	0.179	0.240	0.292	0.377
FLOW COEFFICIENT	0.570	0.527	0.481	0.378
AIRFLOW PER UNIT FRONTAL AREA	39.16	36.59	33.43	26.44
AIRFLOW PER UNIT ANNULUS AREA	108.77	101.64	92.86	73.44
AIRFLOW AT ORIFICE	7.94	7.42	6.78	5.36
AIRFLOW AT ROTOR INLET	8.19	7.64	7.00	5.55
AIRFLOW AT ROTOR OUTLET	7.99	7.43	6.81	5.47
AIRFLOW AT STATOR OUTLET	7.86	7.41	6.80	5.34
ROTATIVE SPEED	6411.3	6429.3	6424.5	6416.5
PERCENT OF DESIGN SPEED	69.9	70.1	70.1	70.0
COMPRESSOR PERFORMANCE				
STAGE TOTAL PRESSURE RATIO	1.053	1.080	1.098	1.120
STAGE TOTAL TEMPERATURE RATIO	1.022	1.027	1.031	1.041
STAGE ADIABATIC EFFICIENCY	0.667	0.821	0.866	0.817

TABLE 19. - Concluded.

(g) 60 Percent of design speed

READING NUMBER	3744
ROTOR TOTAL PRESSURE RATIO	1.097
STATOR TOTAL PRESSURE RATIO	0.991
ROTOR TOTAL TEMPERATURE RATIO	1.030
STATOR TOTAL TEMPERATURE RATIO	1.000
ROTOR ADIABATIC EFFICIENCY	0.896
ROTOR MOMENTUM-RISE EFFICIENCY	0.908
ROTOR HEAD-RISE COEFFICIENT	0.371
FLOW COEFFICIENT	0.372
AIRFLOW PER UNIT FRONTAL AREA	22.53
AIRFLOW PER UNIT ANNULUS AREA	62.57
AIRFLOW AT ORIFICE	4.57
AIRFLOW AT ROTOR INLET	4.73
AIRFLOW AT ROTOR OUTLET	4.69
AIRFLOW AT STATOR OUTLET	4.62
ROTATIVE SPEED	5517.5
PERCENT OF DESIGN SPEED	60.2

COMPRESSOR PERFORMANCE

STAGE TOTAL PRESSURE RATIO	1.087
STAGE TOTAL TEMPERATURE RATIO	1.030
STAGE ADIABATIC EFFICIENCY	0.813

(h) 50 Percent of design speed

READING NUMBER	3746
ROTOR TOTAL PRESSURE RATIO	1.066
STATOR TOTAL PRESSURE RATIO	0.994
ROTOR TOTAL TEMPERATURE RATIO	1.021
STATOR TOTAL TEMPERATURE RATIO	1.000
ROTOR ADIABATIC EFFICIENCY	0.895
ROTOR MOMENTUM-RISE EFFICIENCY	0.901
ROTOR HEAD-RISE COEFFICIENT	0.364
FLOW COEFFICIENT	0.368
AIRFLOW PER UNIT FRONTAL AREA	18.50
AIRFLOW PER UNIT ANNULUS AREA	51.38
AIRFLOW AT ORIFICE	3.75
AIRFLOW AT ROTOR INLET	3.91
AIRFLOW AT ROTOR OUTLET	3.84
AIRFLOW AT STATOR OUTLET	3.85
ROTATIVE SPEED	4591.4
PERCENT OF DESIGN SPEED	50.1

COMPRESSOR PERFORMANCE

STAGE TOTAL PRESSURE RATIO	1.060
STAGE TOTAL TEMPERATURE RATIO	1.021
STAGE ADIABATIC EFFICIENCY	0.801

TABLE 20. - OVERALL PERFORMANCE OF STAGE 23D-20C

(a) 120 Percent of design speed

READING NUMBER	3867	3866	3865	3864	3863
ROTOR TOTAL PRESSURE RATIO	1.316	1.375	1.401	1.440	1.460
STATOR TOTAL PRESSURE RATIO	0.985	0.980	0.978	0.970	0.963
ROTOR TOTAL TEMPERATURE RATIO	1.097	1.106	1.111	1.121	1.128
STATOR TOTAL TEMPERATURE RATIO	0.999	0.998	0.998	0.997	0.998
ROTOR ADIABATIC EFFICIENCY	0.842	0.897	0.911	0.908	0.892
ROTOR MOMENTUM-RISE EFFICIENCY	0.851	0.905	0.923	0.920	0.911
ROTOR HEAD-RISE COEFFICIENT	0.302	0.355	0.382	0.417	0.439
FLOW COEFFICIENT	0.483	0.477	0.460	0.431	0.401
AIRFLOW PER UNIT FRONTAL AREA	54.66	54.09	52.41	49.61	46.30
AIRFLOW PER UNIT ANNULUS AREA	151.84	150.26	145.58	137.80	128.60
AIRFLOW AT ORIFICE	11.08	10.96	10.62	10.05	9.38
AIRFLOW AT ROTOR INLET	11.35	11.24	10.89	10.30	9.66
AIRFLOW AT ROTOR OUTLET	11.37	11.36	11.08	10.59	9.96
AIRFLOW AT STATOR OUTLET	11.04	10.94	10.66	10.21	9.68
ROTATIVE SPEED	11001.9	11010.5	10976.7	10994.1	10956.5
PERCENT OF DESIGN SPEED	120.0	120.1	119.7	119.9	119.5

COMPRESSOR PERFORMANCE

STAGE TOTAL PRESSURE RATIO	1.296	1.347	1.371	1.396	1.406
STAGE TOTAL TEMPERATURE RATIO	1.095	1.103	1.109	1.118	1.126
STAGE ADIABATIC EFFICIENCY	0.807	0.859	0.868	0.850	0.814

(b) 110 Percent of design speed

READING NUMBER	3861	3860	3859
ROTOR TOTAL PRESSURE RATIO	1.255	1.319	1.369
STATOR TOTAL PRESSURE RATIO	0.989	0.984	0.970
ROTOR TOTAL TEMPERATURE RATIO	1.079	1.091	1.106
STATOR TOTAL TEMPERATURE RATIO	0.999	0.998	0.997
ROTOR ADIABATIC EFFICIENCY	0.853	0.907	0.883
ROTOR MOMENTUM-RISE EFFICIENCY	0.862	0.915	0.900
ROTOR HEAD-RISE COEFFICIENT	0.291	0.361	0.420
FLOW COEFFICIENT	0.493	0.453	0.390
AIRFLOW PER UNIT FRONTAL AREA	51.72	48.10	42.01
AIRFLOW PER UNIT ANNULUS AREA	143.66	133.61	116.69
AIRFLOW AT ORIFICE	10.48	9.75	8.51
AIRFLOW AT ROTOR INLET	10.73	9.99	8.73
AIRFLOW AT ROTOR OUTLET	10.63	10.01	8.98
AIRFLOW AT STATOR OUTLET	10.45	9.73	8.60
ROTATIVE SPEED	10082.3	10077.4	10062.0
PERCENT OF DESIGN SPEED	109.9	109.9	109.7

COMPRESSOR PERFORMANCE

STAGE TOTAL PRESSURE RATIO	1.241	1.298	1.328
STAGE TOTAL TEMPERATURE RATIO	1.077	1.089	1.104
STAGE ADIABATIC EFFICIENCY	0.823	0.868	0.816

(c) 100 Percent of design speed

READING NUMBER	3857	3856	3852	3853	3855
ROTOR TOTAL PRESSURE RATIO	1.183	1.230	1.252	1.279	1.304
STATOR TOTAL PRESSURE RATIO	0.992	0.989	0.988	0.982	0.972
ROTOR TOTAL TEMPERATURE RATIO	1.059	1.068	1.073	1.081	1.090
STATOR TOTAL TEMPERATURE RATIO	1.000	0.999	0.999	0.998	0.997
ROTOR ADIABATIC EFFICIENCY	0.836	0.892	0.902	0.903	0.878
ROTOR MOMENTUM-RISE EFFICIENCY	0.834	0.902	0.919	0.916	0.894
ROTOR HEAD-RISE COEFFICIENT	0.252	0.315	0.348	0.384	0.417
FLOW COEFFICIENT	0.510	0.479	0.449	0.418	0.378
AIRFLOW PER UNIT FRONTAL AREA	49.25	46.53	43.71	41.02	37.46
AIRFLOW PER UNIT ANNULUS AREA	136.80	129.25	121.41	113.93	104.05
AIRFLOW AT ORIFICE	9.98	9.43	8.86	8.31	7.59
AIRFLOW AT ROTOR INLET	10.22	9.68	9.10	8.54	7.80
AIRFLOW AT ROTOR OUTLET	10.09	9.61	9.08	8.64	8.06
AIRFLOW AT STATOR OUTLET	10.06	9.38	8.84	8.32	7.69
ROTATIVE SPEED	9199.8	9187.4	9143.9	9156.8	9176.2
PERCENT OF DESIGN SPEED	100.3	100.2	99.7	99.9	100.1

COMPRESSOR PERFORMANCE

STAGE TOTAL PRESSURE RATIO	1.173	1.216	1.237	1.255	1.267
STAGE TOTAL TEMPERATURE RATIO	1.059	1.067	1.072	1.078	1.086
STAGE ADIABATIC EFFICIENCY	0.789	0.858	0.867	0.856	0.810

TABLE 20. - Continued.

(d) 90 Percent of design speed

READING NUMBER	3873	3872	3871	3870	3869
ROTOR TOTAL PRESSURE RATIO	1.122	1.167	1.194	1.215	1.235
STATOR TOTAL PRESSURE RATIO	0.992	0.993	0.990	0.988	0.981
ROTOR TOTAL TEMPERATURE RATIO	1.041	1.051	1.057	1.063	1.070
STATOR TOTAL TEMPERATURE RATIO	1.001	1.000	0.999	0.999	0.999
ROTOR ADIABATIC EFFICIENCY	0.806	0.887	0.903	0.902	0.886
ROTOR MOMENTUM-RISE EFFICIENCY	0.810	0.906	0.922	0.925	0.899
ROTOR HEAD-RISE COEFFICIENT	0.209	0.285	0.330	0.366	0.400
FLOW COEFFICIENT	0.534	0.497	0.455	0.417	0.374
AIRFLOW PER UNIT FRONTAL AREA	46.56	43.51	40.19	37.03	33.50
AIRFLOW PER UNIT ANNULUS AREA	129.33	120.87	111.65	102.87	93.05
AIRFLOW AT ORIFICE	9.44	8.82	8.15	7.51	6.79
AIRFLOW AT ROTOR INLET	9.68	9.07	8.39	7.73	6.99
AIRFLOW AT ROTOR OUTLET	9.58	9.02	8.41	7.79	7.14
AIRFLOW AT STATOR OUTLET	9.56	8.89	8.19	7.61	6.97
ROTATIVE SPEED	8248.5	8242.1	8249.6	8246.4	8253.6
PERCENT OF DESIGN SPEED	90.0	89.9	90.0	89.9	90.0
COMPRESSOR PERFORMANCE					
STAGE TOTAL PRESSURE RATIO	1.112	1.158	1.182	1.201	1.211
STAGE TOTAL TEMPERATURE RATIO	1.043	1.051	1.057	1.063	1.069
STAGE ADIABATIC EFFICIENCY	0.723	0.843	0.861	0.856	0.812

(e) 80 Percent of design speed

READING NUMBER	3875
ROTOR TOTAL PRESSURE RATIO	1.183
STATOR TOTAL PRESSURE RATIO	0.985
ROTOR TOTAL TEMPERATURE RATIO	1.056
STATOR TOTAL TEMPERATURE RATIO	1.000
ROTOR ADIABATIC EFFICIENCY	0.885
ROTOR MOMENTUM-RISE EFFICIENCY	0.904
ROTOR HEAD-RISE COEFFICIENT	0.393
FLOW COEFFICIENT	0.364
AIRFLOW PER UNIT FRONTAL AREA	29.23
AIRFLOW PER UNIT ANNULUS AREA	81.19
AIRFLOW AT ORIFICE	5.92
AIRFLOW AT ROTOR INLET	6.11
AIRFLOW AT ROTOR OUTLET	6.26
AIRFLOW AT STATOR OUTLET	6.11
ROTATIVE SPEED	7356.3
PERCENT OF DESIGN SPEED	80.2
COMPRESSOR PERFORMANCE	
STAGE TOTAL PRESSURE RATIO	1.166
STAGE TOTAL TEMPERATURE RATIO	1.055
STAGE ADIABATIC EFFICIENCY	0.807

(f) 70 Percent of design speed

READING NUMBER	3881	3880	3879	3878	3877
ROTOR TOTAL PRESSURE RATIO	1.075	1.094	1.109	1.124	1.139
STATOR TOTAL PRESSURE RATIO	0.994	0.995	0.994	0.993	0.987
ROTOR TOTAL TEMPERATURE RATIO	1.024	1.029	1.033	1.037	1.042
STATOR TOTAL TEMPERATURE RATIO	1.002	1.001	1.001	1.000	1.000
ROTOR ADIABATIC EFFICIENCY	0.862	0.902	0.914	0.915	0.895
ROTOR MOMENTUM-RISE EFFICIENCY	0.860	0.908	0.921	0.922	0.901
ROTOR HEAD-RISE COEFFICIENT	0.211	0.264	0.305	0.351	0.388
FLOW COEFFICIENT	0.534	0.499	0.459	0.411	0.360
AIRFLOW PER UNIT FRONTAL AREA	37.08	34.74	32.10	28.78	25.45
AIRFLOW PER UNIT ANNULUS AREA	102.99	96.51	89.16	79.94	70.71
AIRFLOW AT ORIFICE	7.51	7.04	6.51	5.83	5.16
AIRFLOW AT ROTOR INLET	7.72	7.25	6.72	6.02	5.32
AIRFLOW AT ROTOR OUTLET	7.63	7.20	6.70	6.09	5.47
AIRFLOW AT STATOR OUTLET	7.59	7.10	6.55	5.92	5.30
ROTATIVE SPEED	6419.2	6432.3	6443.2	6419.3	6445.3
PERCENT OF DESIGN SPEED	70.0	70.1	70.3	70.0	70.3
COMPRESSOR PERFORMANCE					
STAGE TOTAL PRESSURE RATIO	1.068	1.088	1.103	1.116	1.124
STAGE TOTAL TEMPERATURE RATIO	1.026	1.030	1.033	1.037	1.042
STAGE ADIABATIC EFFICIENCY	0.746	0.827	0.850	0.851	0.805

TABLE 20. - Concluded.

(g) 60 Percent of design speed

READING NUMBER	3883
ROTOR TOTAL PRESSURE RATIO	1.100
STATOR TOTAL PRESSURE RATIO	0.991
ROTOR TOTAL TEMPERATURE RATIO	1.031
STATOR TOTAL TEMPERATURE RATIO	1.000
ROTOR ADIABATIC EFFICIENCY	0.896
ROTOR MOMENTUM-RISE EFFICIENCY	0.907
ROTOR HEAD-RISE COEFFICIENT	0.382
FLOW COEFFICIENT	0.358
AIRFLOW PER UNIT FRONTAL AREA	21.74
AIRFLOW PER UNIT ANNULUS AREA	60.39
AIRFLOW AT ORIFICE	4.41
AIRFLOW AT ROTOR INLET	4.55
AIRFLOW AT ROTOR OUTLET	4.74
AIRFLOW AT STATOR OUTLET	4.54
ROTATIVE SPEED	5512.3
PERCENT OF DESIGN SPEED	60.1

COMPRESSOR PERFORMANCE

STAGE TOTAL PRESSURE RATIO	1.089
STAGE TOTAL TEMPERATURE RATIO	1.031
STAGE ADIABATIC EFFICIENCY	0.804

(h) 50 Percent of design speed

READING NUMBER	3885
ROTOR TOTAL PRESSURE RATIO	1.068
STATOR TOTAL PRESSURE RATIO	0.994
ROTOR TOTAL TEMPERATURE RATIO	1.021
STATOR TOTAL TEMPERATURE RATIO	1.001
ROTOR ADIABATIC EFFICIENCY	0.896
ROTOR MOMENTUM-RISE EFFICIENCY	0.901
ROTOR HEAD-RISE COEFFICIENT	0.370
FLOW COEFFICIENT	0.359
AIRFLOW PER UNIT FRONTAL AREA	18.27
AIRFLOW PER UNIT ANNULUS AREA	50.74
AIRFLOW AT ORIFICE	3.70
AIRFLOW AT ROTOR INLET	3.83
AIRFLOW AT ROTOR OUTLET	3.94
AIRFLOW AT STATOR OUTLET	3.83
ROTATIVE SPEED	4619.0
PERCENT OF DESIGN SPEED	50.4

COMPRESSOR PERFORMANCE

STAGE TOTAL PRESSURE RATIO	1.061
STAGE TOTAL TEMPERATURE RATIO	1.022
STAGE ADIABATIC EFFICIENCY	0.794

TABLE 21. - OVERALL PERFORMANCE OF STAGE 24A-20

(a) 120 Percent of design speed

READING NUMBER	3685	3682	3683
ROTOR TOTAL PRESSURE RATIO	1.307	1.385	1.466
STATOR TOTAL PRESSURE RATIO	0.986	0.981	0.961
ROTOR TOTAL TEMPERATURE RATIO	1.092	1.107	1.129
STATOR TOTAL TEMPERATURE RATIO	1.000	0.998	0.998
ROTOR ADIABATIC EFFICIENCY	0.864	0.912	0.893
ROTOR MOMENTUM-RISE EFFICIENCY	0.855	0.914	0.897
ROTOR HEAD-RISE COEFFICIENT	0.293	0.365	0.440
FLOW COEFFICIENT	0.518	0.490	0.410
AIRFLOW PER UNIT FRONTAL AREA	58.12	55.43	47.68
AIRFLOW PER UNIT ANNULUS AREA	161.46	153.98	132.44
AIRFLOW AT ORIFICE	11.78	11.24	9.66
AIRFLOW AT ROTOR INLET	12.05	11.50	9.90
AIRFLOW AT ROTOR OUTLET	11.93	11.58	10.33
AIRFLOW AT STATOR OUTLET	11.67	11.12	9.77
ROTATIVE SPEED	11013.3	11004.8	11014.6
PERCENT OF DESIGN SPEED	120.1	120.0	120.1

COMPRESSOR PERFORMANCE

STAGE TOTAL PRESSURE RATIO	1.289	1.359	1.409
STAGE TOTAL TEMPERATURE RATIO	1.092	1.105	1.127
STAGE ADIABATIC EFFICIENCY	0.821	0.875	0.811

(b) 110 Percent of design speed

READING NUMBER	3678	3677	3679
ROTOR TOTAL PRESSURE RATIO	1.218	1.311	1.374
STATOR TOTAL PRESSURE RATIO	0.991	0.984	0.967
ROTOR TOTAL TEMPERATURE RATIO	1.069	1.088	1.107
STATOR TOTAL TEMPERATURE RATIO	1.001	0.999	0.998
ROTOR ADIABATIC EFFICIENCY	0.843	0.915	0.888
ROTOR MOMENTUM-RISE EFFICIENCY	0.837	0.915	0.894
ROTOR HEAD-RISE COEFFICIENT	0.249	0.352	0.422
FLOW COEFFICIENT	0.532	0.480	0.402
AIRFLOW PER UNIT FRONTAL AREA	55.29	50.63	43.35
AIRFLOW PER UNIT ANNULUS AREA	153.60	140.64	120.41
AIRFLOW AT ORIFICE	11.21	10.26	8.79
AIRFLOW AT ROTOR INLET	11.47	10.52	9.02
AIRFLOW AT ROTOR OUTLET	11.23	10.58	9.36
AIRFLOW AT STATOR OUTLET	11.15	10.22	8.89
ROTATIVE SPEED	10107.0	10090.1	10107.2
PERCENT OF DESIGN SPEED	110.2	110.0	110.2

COMPRESSOR PERFORMANCE

STAGE TOTAL PRESSURE RATIO	1.207	1.290	1.329
STAGE TOTAL TEMPERATURE RATIO	1.070	1.086	1.105
STAGE ADIABATIC EFFICIENCY	0.794	0.873	0.811

(c) 100 Percent of design speed

READING NUMBER	3671	3672	3673	3674	3675
ROTOR TOTAL PRESSURE RATIO	1.146	1.207	1.237	1.267	1.291
STATOR TOTAL PRESSURE RATIO	0.988	0.991	0.989	0.987	0.979
ROTOR TOTAL TEMPERATURE RATIO	1.049	1.061	1.069	1.077	1.085
STATOR TOTAL TEMPERATURE RATIO	1.001	1.000	0.999	1.000	1.000
ROTOR ADIABATIC EFFICIENCY	0.814	0.899	0.910	0.908	0.887
ROTOR MOMENTUM-RISE EFFICIENCY	0.802	0.899	0.915	0.918	0.899
ROTOR HEAD-RISE COEFFICIENT	0.203	0.288	0.328	0.367	0.400
FLOW COEFFICIENT	0.552	0.513	0.480	0.440	0.398
AIRFLOW PER UNIT FRONTAL AREA	52.56	49.29	46.50	43.07	39.24
AIRFLOW PER UNIT ANNULUS AREA	146.00	136.91	129.16	119.64	109.01
AIRFLOW AT ORIFICE	10.65	9.99	9.42	8.73	7.95
AIRFLOW AT ROTOR INLET	10.91	10.23	9.67	8.95	8.17
AIRFLOW AT ROTOR OUTLET	10.56	10.11	9.67	9.00	8.34
AIRFLOW AT STATOR OUTLET	10.54	9.93	9.43	8.75	8.04
ROTATIVE SPEED	9156.7	9138.1	9141.8	9164.9	9164.4
PERCENT OF DESIGN SPEED	99.9	99.7	99.7	99.9	99.9

COMPRESSOR PERFORMANCE

STAGE TOTAL PRESSURE RATIO	1.132	1.196	1.224	1.250	1.263
STAGE TOTAL TEMPERATURE RATIO	1.050	1.061	1.068	1.076	1.085
STAGE ADIABATIC EFFICIENCY	0.719	0.855	0.873	0.862	0.813

TABLE 21. - Continued.

(d) 90 Percent of design speed

READING NUMBER	3686	3687	3688	3689	3690
ROTOR TOTAL PRESSURE RATIO	1.122	1.157	1.193	1.214	1.232
STATOR TOTAL PRESSURE RATIO	0.989	0.993	0.990	0.988	0.982
ROTOR TOTAL TEMPERATURE RATIO	1.039	1.047	1.057	1.063	1.070
STATOR TOTAL TEMPERATURE RATIO	1.001	1.000	1.000	1.000	1.000
ROTOR ADIABATIC EFFICIENCY	0.859	0.898	0.911	0.909	0.882
ROTOR MOMENTUM-RISE EFFICIENCY	0.854	0.898	0.915	0.923	0.895
ROTOR HEAD-RISE COEFFICIENT	0.208	0.267	0.328	0.363	0.393
FLOW COEFFICIENT	0.556	0.516	0.467	0.433	0.385
AIRFLOW PER UNIT FRONTAL AREA	48.28	45.28	41.38	38.48	34.53
AIRFLOW PER UNIT ANNULUS AREA	134.11	125.77	114.96	106.89	95.91
AIRFLOW AT ORIFICE	9.79	9.18	8.39	7.80	7.00
AIRFLOW AT ROTOR INLET	10.03	9.41	8.61	8.02	7.21
AIRFLOW AT ROTOR OUTLET	9.80	9.24	8.60	8.10	7.32
AIRFLOW AT STATOR OUTLET	9.68	9.12	8.40	7.82	7.08
ROTATIVE SPEED	8246.6	8260.6	8257.2	8258.7	8277.6
PERCENT OF DESIGN SPEED	89.9	90.1	90.0	90.1	90.3

COMPRESSOR PERFORMANCE

STAGE TOTAL PRESSURE RATIO	1.109	1.149	1.181	1.199	1.210
STAGE TOTAL TEMPERATURE RATIO	1.040	1.048	1.056	1.062	1.070
STAGE ADIABATIC EFFICIENCY	0.745	0.844	0.868	0.856	0.805

(e) 80 Percent of design speed

READING NUMBER	3693
ROTOR TOTAL PRESSURE RATIO	1.180
STATOR TOTAL PRESSURE RATIO	0.984
ROTOR TOTAL TEMPERATURE RATIO	1.055
STATOR TOTAL TEMPERATURE RATIO	1.000
ROTOR ADIABATIC EFFICIENCY	0.888
ROTOR MOMENTUM-RISE EFFICIENCY	0.893
ROTOR HEAD-RISE COEFFICIENT	0.390
FLOW COEFFICIENT	0.378
AIRFLOW PER UNIT FRONTAL AREA	30.14
AIRFLOW PER UNIT ANNULUS AREA	83.72
AIRFLOW AT ORIFICE	6.11
AIRFLOW AT ROTOR INLET	6.30
AIRFLOW AT ROTOR OUTLET	6.45
AIRFLOW AT STATOR OUTLET	6.19
ROTATIVE SPEED	7317.8
PERCENT OF DESIGN SPEED	79.8

COMPRESSOR PERFORMANCE

STAGE TOTAL PRESSURE RATIO	1.161
STAGE TOTAL TEMPERATURE RATIO	1.054
STAGE ADIABATIC EFFICIENCY	0.800

(f) 70 Percent of design speed

READING NUMBER	3696	3697	3698	3700	3701
ROTOR TOTAL PRESSURE RATIO	1.077	1.092	1.106	1.121	1.135
STATOR TOTAL PRESSURE RATIO	0.993	0.994	0.995	0.994	0.988
ROTOR TOTAL TEMPERATURE RATIO	1.024	1.028	1.032	1.036	1.041
STATOR TOTAL TEMPERATURE RATIO	1.001	1.001	1.001	1.001	1.000
ROTOR ADIABATIC EFFICIENCY	0.892	0.914	0.911	0.919	0.887
ROTOR MOMENTUM-RISE EFFICIENCY	0.871	0.895	0.909	0.919	0.891
ROTOR HEAD-RISE COEFFICIENT	0.216	0.257	0.296	0.341	0.380
FLOW COEFFICIENT	0.544	0.507	0.470	0.421	0.369
AIRFLOW PER UNIT FRONTAL AREA	37.71	35.26	32.89	29.44	25.94
AIRFLOW PER UNIT ANNULUS AREA	104.75	97.94	91.37	81.79	72.05
AIRFLOW AT ORIFICE	7.64	7.15	6.67	5.97	5.26
AIRFLOW AT ROTOR INLET	7.90	7.38	6.90	6.18	5.44
AIRFLOW AT ROTOR OUTLET	7.62	7.18	6.75	6.13	5.50
AIRFLOW AT STATOR OUTLET	7.54	7.04	6.59	5.95	5.30
ROTATIVE SPEED	6455.6	6442.4	6459.1	6430.8	6418.1
PERCENT OF DESIGN SPEED	70.4	70.3	70.4	70.1	70.0

COMPRESSOR PERFORMANCE

STAGE TOTAL PRESSURE RATIO	1.070	1.086	1.100	1.115	1.121
STAGE TOTAL TEMPERATURE RATIO	1.026	1.029	1.033	1.037	1.042
STAGE ADIABATIC EFFICIENCY	0.763	0.828	0.848	0.848	0.789

TABLE 21. - Concluded.

(g) 60 Percent of design speed

READING NUMBER	3704
ROTOR TOTAL PRESSURE RATIO	1.096
STATOR TOTAL PRESSURE RATIO	0.992
ROTOR TOTAL TEMPERATURE RATIO	1.030
STATOR TOTAL TEMPERATURE RATIO	1.001
ROTOR ADIABATIC EFFICIENCY	0.894
ROTOR MOMENTUM-RISE EFFICIENCY	0.901
ROTOR HEAD-RISE COEFFICIENT	0.369
FLOW COEFFICIENT	0.372
AIRFLOW PER UNIT FRONTAL AREA	22.52
AIRFLOW PER UNIT ANNULUS AREA	62.57
AIRFLOW AT ORIFICE	4.57
AIRFLOW AT ROTOR INLET	4.73
AIRFLOW AT ROTOR OUTLET	4.77
AIRFLOW AT STATOR OUTLET	4.60
ROTATIVE SPEED	5508.3
PERCENT OF DESIGN SPEED	60.1

COMPRESSOR PERFORMANCE

STAGE TOTAL PRESSURE RATIO	1.088
STAGE TOTAL TEMPERATURE RATIO	1.031
STAGE ADIABATIC EFFICIENCY	0.796

(h) 50 Percent of design speed

READING NUMBER	3706
ROTOR TOTAL PRESSURE RATIO	1.061
STATOR TOTAL PRESSURE RATIO	0.994
ROTOR TOTAL TEMPERATURE RATIO	1.019
STATOR TOTAL TEMPERATURE RATIO	1.001
ROTOR ADIABATIC EFFICIENCY	0.891
ROTOR MOMENTUM-RISE EFFICIENCY	0.894
ROTOR HEAD-RISE COEFFICIENT	0.366
FLOW COEFFICIENT	0.364
AIRFLOW PER UNIT FRONTAL AREA	17.72
AIRFLOW PER UNIT ANNULUS AREA	49.21
AIRFLOW AT ORIFICE	3.59
AIRFLOW AT ROTOR INLET	3.73
AIRFLOW AT ROTOR OUTLET	3.76
AIRFLOW AT STATOR OUTLET	3.56
ROTATIVE SPEED	4416.6
PERCENT OF DESIGN SPEED	48.2

COMPRESSOR PERFORMANCE

STAGE TOTAL PRESSURE RATIO	1.055
STAGE TOTAL TEMPERATURE RATIO	1.020
STAGE ADIABATIC EFFICIENCY	0.771

TABLE 22. - OVERALL PERFORMANCE OF STAGE 24B-20C

(a) 120 Percent of design speed

READING NUMBER	3825	3828	3822	3827	3824
ROTOR TOTAL PRESSURE RATIO	1.319	1.370	1.410	1.453	1.482
STATOR TOTAL PRESSURE RATIO	0.986	0.983	0.978	0.968	0.957
ROTOR TOTAL TEMPERATURE RATIO	1.097	1.106	1.114	1.126	1.135
STATOR TOTAL TEMPERATURE RATIO	0.999	0.998	0.997	0.996	0.997
ROTOR ADIABATIC EFFICIENCY	0.852	0.891	0.901	0.896	0.883
ROTOR MOMENTUM-RISE EFFICIENCY	0.864	0.908	0.923	0.925	0.911
ROTOR HEAD-RISE COEFFICIENT	0.303	0.351	0.387	0.429	0.453
FLOW COEFFICIENT	0.490	0.480	0.459	0.423	0.390
AIRFLOW PER UNIT FRONTAL AREA	55.58	54.50	52.59	49.05	45.72
AIRFLOW PER UNIT ANNULUS AREA	154.38	151.40	146.10	136.24	127.01
AIRFLOW AT ORIFICE	11.26	11.05	10.66	9.94	9.27
AIRFLOW AT ROTOR INLET	11.52	11.31	10.91	10.15	9.48
AIRFLOW AT ROTOR OUTLET	11.39	11.23	10.94	10.40	9.79
AIRFLOW AT STATOR OUTLET	11.24	10.99	10.59	9.93	9.38
ROTATIVE SPEED	11040.7	11019.5	11025.0	11007.3	11039.9
PERCENT OF DESIGN SPEED	120.4	120.2	120.2	120.0	120.4

COMPRESSOR PERFORMANCE

STAGE TOTAL PRESSURE RATIO	1.301	1.346	1.378	1.406	1.419
STAGE TOTAL TEMPERATURE RATIO	1.095	1.103	1.111	1.121	1.132
STAGE ADIABATIC EFFICIENCY	0.820	0.862	0.867	0.843	0.797

(b) 110 Percent of design speed

READING NUMBER	3820	3821	3818
ROTOR TOTAL PRESSURE RATIO	1.241	1.323	1.381
STATOR TOTAL PRESSURE RATIO	0.990	0.984	0.964
ROTOR TOTAL TEMPERATURE RATIO	1.075	1.093	1.111
STATOR TOTAL TEMPERATURE RATIO	0.999	0.998	0.996
ROTOR ADIABATIC EFFICIENCY	0.848	0.898	0.874
ROTOR MOMENTUM-RISE EFFICIENCY	0.857	0.922	0.903
ROTOR HEAD-RISE COEFFICIENT	0.275	0.365	0.432
FLOW COEFFICIENT	0.502	0.451	0.387
AIRFLOW PER UNIT FRONTAL AREA	52.65	48.00	41.60
AIRFLOW PER UNIT ANNULUS AREA	146.25	133.32	115.55
AIRFLOW AT ORIFICE	10.67	9.73	8.43
AIRFLOW AT ROTOR INLET	10.92	9.97	8.71
AIRFLOW AT ROTOR OUTLET	10.78	9.91	8.90
AIRFLOW AT STATOR OUTLET	10.73	9.68	8.46
ROTATIVE SPEED	10086.3	10089.7	10081.7
PERCENT OF DESIGN SPEED	110.0	110.0	109.9

COMPRESSOR PERFORMANCE

STAGE TOTAL PRESSURE RATIO	1.228	1.301	1.331
STAGE TOTAL TEMPERATURE RATIO	1.074	1.090	1.107
STAGE ADIABATIC EFFICIENCY	0.812	0.865	0.798

(c) 100 Percent of design speed

READING NUMBER	3813	3812	3817	3814	3816
ROTOR TOTAL PRESSURE RATIO	1.160	1.225	1.256	1.280	1.297
STATOR TOTAL PRESSURE RATIO	0.990	0.990	0.987	0.983	0.975
ROTOR TOTAL TEMPERATURE RATIO	1.054	1.067	1.075	1.082	1.088
STATOR TOTAL TEMPERATURE RATIO	1.001	0.999	0.998	0.998	0.998
ROTOR ADIABATIC EFFICIENCY	0.807	0.886	0.898	0.891	0.873
ROTOR MOMENTUM-RISE EFFICIENCY	0.803	0.900	0.916	0.927	0.906
ROTOR HEAD-RISE COEFFICIENT	0.222	0.309	0.352	0.386	0.412
FLOW COEFFICIENT	0.524	0.481	0.447	0.415	0.380
AIRFLOW PER UNIT FRONTAL AREA	50.34	46.73	43.69	40.82	37.49
AIRFLOW PER UNIT ANNULUS AREA	139.83	129.81	121.37	113.40	104.14
AIRFLOW AT ORIFICE	10.20	9.47	8.86	8.27	7.60
AIRFLOW AT ROTOR INLET	10.44	9.71	9.09	8.49	7.80
AIRFLOW AT ROTOR OUTLET	10.24	9.58	9.01	8.54	7.86
AIRFLOW AT STATOR OUTLET	10.25	9.50	8.90	8.32	7.64
ROTATIVE SPEED	9177.1	9187.0	9175.4	9168.7	9130.5
PERCENT OF DESIGN SPEED	100.1	100.2	100.1	100.0	99.6

COMPRESSOR PERFORMANCE

STAGE TOTAL PRESSURE RATIO	1.148	1.212	1.240	1.259	1.265
STAGE TOTAL TEMPERATURE RATIO	1.054	1.066	1.073	1.080	1.087
STAGE ADIABATIC EFFICIENCY	0.740	0.852	0.862	0.847	0.802

TABLE 22. - Continued.

(d) 90 Percent of design speed

READING NUMBER	3832	3833	3834	3835	3830
ROTOR TOTAL PRESSURE RATIO	1.136	1.171	1.205	1.228	1.238
STATOR TOTAL PRESSURE RATIO	0.993	0.993	0.990	0.984	0.980
ROTOR TOTAL TEMPERATURE RATIO	1.044	1.052	1.061	1.068	1.072
STATOR TOTAL TEMPERATURE RATIO	1.001	1.000	0.999	0.998	0.999
ROTOR ADIABATIC EFFICIENCY	0.846	0.891	0.906	0.896	0.880
ROTOR MOMENTUM-RISE EFFICIENCY	0.842	0.892	0.915	0.921	0.904
ROTOR HEAD-RISE COEFFICIENT	0.231	0.291	0.347	0.387	0.405
FLOW COEFFICIENT	0.527	0.486	0.443	0.407	0.376
AIRFLOW PER UNIT FRONTAL AREA	46.20	42.90	39.42	36.40	33.74
AIRFLOW PER UNIT ANNULUS AREA	128.33	119.18	109.51	101.11	93.73
AIRFLOW AT ORIFICE	9.36	8.70	7.99	7.38	6.84
AIRFLOW AT ROTOR INLET	9.60	8.93	8.21	7.58	7.03
AIRFLOW AT ROTOR OUTLET	9.35	8.75	8.15	7.65	7.08
AIRFLOW AT STATOR OUTLET	9.45	8.81	8.10	7.49	6.99
ROTATIVE SPEED	8280.7	8274.7	8281.4	8271.7	8255.3
PERCENT OF DESIGN SPEED	90.3	90.2	90.3	90.2	90.0

COMPRESSOR PERFORMANCE

STAGE TOTAL PRESSURE RATIO	1.128	1.164	1.193	1.209	1.213
STAGE TOTAL TEMPERATURE RATIO	1.045	1.052	1.060	1.066	1.070
STAGE ADIABATIC EFFICIENCY	0.783	0.848	0.863	0.846	0.810

(e) 80 Percent of design speed

READING NUMBER					3837
ROTOR TOTAL PRESSURE RATIO					1.188
STATOR TOTAL PRESSURE RATIO					0.982
ROTOR TOTAL TEMPERATURE RATIO					1.057
STATOR TOTAL TEMPERATURE RATIO					0.999
ROTOR ADIABATIC EFFICIENCY					0.880
ROTOR MOMENTUM-RISE EFFICIENCY					0.901
ROTOR HEAD-RISE COEFFICIENT					0.404
FLOW COEFFICIENT					0.365
AIRFLOW PER UNIT FRONTAL AREA					29.36
AIRFLOW PER UNIT ANNULUS AREA					81.55
AIRFLOW AT ORIFICE					5.95
AIRFLOW AT ROTOR INLET					6.12
AIRFLOW AT ROTOR OUTLET					6.20
AIRFLOW AT STATOR OUTLET					6.10
ROTATIVE SPEED					7359.2
PERCENT OF DESIGN SPEED					80.3

COMPRESSOR PERFORMANCE

STAGE TOTAL PRESSURE RATIO	1.167
STAGE TOTAL TEMPERATURE RATIO	1.057
STAGE ADIABATIC EFFICIENCY	0.797

(f) 70 Percent of design speed

READING NUMBER	3843	3842	3841	3840	3839
ROTOR TOTAL PRESSURE RATIO	1.077	1.093	1.110	1.128	1.138
STATOR TOTAL PRESSURE RATIO	0.995	0.996	0.996	0.991	0.989
ROTOR TOTAL TEMPERATURE RATIO	1.025	1.029	1.033	1.038	1.043
STATOR TOTAL TEMPERATURE RATIO	1.001	1.001	1.001	1.000	1.000
ROTOR ADIABATIC EFFICIENCY	0.857	0.895	0.910	0.920	0.878
ROTOR MOMENTUM-RISE EFFICIENCY	0.855	0.891	0.911	0.917	0.901
ROTOR HEAD-RISE COEFFICIENT	0.217	0.261	0.311	0.359	0.388
FLOW COEFFICIENT	0.532	0.496	0.450	0.411	0.365
AIRFLOW PER UNIT FRONTAL AREA	37.10	34.67	31.45	28.88	25.68
AIRFLOW PER UNIT ANNULUS AREA	103.07	96.30	87.36	80.23	71.34
AIRFLOW AT ORIFICE	7.52	7.03	6.37	5.85	5.21
AIRFLOW AT ROTOR INLET	7.73	7.23	6.57	6.04	5.39
AIRFLOW AT ROTOR OUTLET	7.47	7.02	6.44	6.09	5.37
AIRFLOW AT STATOR OUTLET	7.55	7.09	6.47	6.00	5.36
ROTATIVE SPEED	6448.9	6446.7	6417.3	6441.0	6440.7
PERCENT OF DESIGN SPEED	70.3	70.3	70.0	70.2	70.2

COMPRESSOR PERFORMANCE

STAGE TOTAL PRESSURE RATIO	1.072	1.089	1.105	1.118	1.126
STAGE TOTAL TEMPERATURE RATIO	1.026	1.030	1.034	1.038	1.043
STAGE ADIABATIC EFFICIENCY	0.758	0.825	0.848	0.851	0.798

TABLE 22. - Concluded.

(g) 60 Percent of design speed.

READING NUMBER	3846
ROTOR TOTAL PRESSURE RATIO	1.100
STATOR TOTAL PRESSURE RATIO	0.991
ROTOR TOTAL TEMPERATURE RATIO	1.031
STATOR TOTAL TEMPERATURE RATIO	1.000
ROTOR ADIABATIC EFFICIENCY	0.891
ROTOR MOMENTUM-RISE EFFICIENCY	0.900
ROTOR HEAD-RISE COEFFICIENT	0.387
FLOW COEFFICIENT	0.361
AIRFLOW PER UNIT FRONTAL AREA	21.83
AIRFLOW PER UNIT ANNULUS AREA	60.64
AIRFLOW AT ORIFICE	4.42
AIRFLOW AT ROTOR INLET	4.57
AIRFLOW AT ROTOR OUTLET	4.61
AIRFLOW AT STATOR OUTLET	4.54
ROTATIVE SPEED	5485.0
PERCENT OF DESIGN SPEED	59.8
COMPRESSOR PERFORMANCE	
STAGE TOTAL PRESSURE RATIO	1.090
STAGE TOTAL TEMPERATURE RATIO	1.031
STAGE ADIABATIC EFFICIENCY	0.797

(h) 50 Percent of design speed

READING NUMBER	3848
ROTOR TOTAL PRESSURE RATIO	1.069
STATOR TOTAL PRESSURE RATIO	0.994
ROTOR TOTAL TEMPERATURE RATIO	1.022
STATOR TOTAL TEMPERATURE RATIO	1.001
ROTOR ADIABATIC EFFICIENCY	0.891
ROTOR MOMENTUM-RISE EFFICIENCY	0.896
ROTOR HEAD-RISE COEFFICIENT	0.379
FLOW COEFFICIENT	0.357
AIRFLOW PER UNIT FRONTAL AREA	18.18
AIRFLOW PER UNIT ANNULUS AREA	50.49
AIRFLOW AT ORIFICE	3.68
AIRFLOW AT ROTOR INLET	3.81
AIRFLOW AT ROTOR OUTLET	3.82
AIRFLOW AT STATOR OUTLET	3.80
ROTATIVE SPEED	4613.5
PERCENT OF DESIGN SPEED	50.3
COMPRESSOR PERFORMANCE	
STAGE TOTAL PRESSURE RATIO	1.062
STAGE TOTAL TEMPERATURE RATIO	1.022
STAGE ADIABATIC EFFICIENCY	0.786

TABLE 23. - OVERALL PERFORMANCE OF STAGE 25A-20B

(a) 120 Percent of design speed

READING NUMBER	3654	3653	3652	3651	3650
ROTOR TOTAL PRESSURE RATIO	1.228	1.280	1.324	1.350	1.372
STATOR TOTAL PRESSURE RATIO	0.987	0.988	0.986	0.984	0.979
ROTOR TOTAL TEMPERATURE RATIO	1.075	1.085	1.093	1.099	1.105
STATOR TOTAL TEMPERATURE RATIO	1.002	1.001	1.001	1.001	1.000
ROTOR ADIABATIC EFFICIENCY	0.802	0.863	0.895	0.906	0.902
ROTOR MOMENTUM-RISE EFFICIENCY	0.836	0.888	0.906	0.913	0.910
ROTOR HEAD-RISE COEFFICIENT	0.219	0.267	0.308	0.333	0.353
FLOW COEFFICIENT	0.502	0.497	0.483	0.465	0.440
AIRFLOW PER UNIT FRONTAL AREA	57.51	57.03	55.73	53.84	51.55
AIRFLOW PER UNIT ANNULUS AREA	159.76	158.41	154.82	149.56	143.19
AIRFLOW AT ORIFICE	11.66	11.56	11.30	10.91	10.45
AIRFLOW AT ROTOR INLET	11.72	11.63	11.35	10.98	10.49
AIRFLOW AT ROTOR OUTLET	11.63	11.45	11.09	10.66	10.11
AIRFLOW AT STATOR OUTLET	11.33	11.30	11.12	10.68	10.10
ROTATIVE SPEED	11008.7	11017.5	11019.5	11000.7	11003.9
PERCENT OF DESIGN SPEED	120.1	120.1	120.2	120.0	120.0

COMPRESSOR PERFORMANCE

STAGE TOTAL PRESSURE RATIO	1.211	1.264	1.306	1.328	1.342
STAGE TOTAL TEMPERATURE RATIO	1.078	1.086	1.094	1.099	1.105
STAGE ADIABATIC EFFICIENCY	0.726	0.805	0.841	0.848	0.835

(b) 110 Percent of design speed

READING NUMBER	3649	3648	3646	3645	3644
ROTOR TOTAL PRESSURE RATIO	1.162	1.227	1.262	1.296	1.296
STATOR TOTAL PRESSURE RATIO	0.987	0.991	0.989	0.988	0.986
ROTOR TOTAL TEMPERATURE RATIO	1.056	1.069	1.076	1.081	1.086
STATOR TOTAL TEMPERATURE RATIO	1.002	1.001	1.001	1.001	1.001
ROTOR ADIABATIC EFFICIENCY	0.784	0.876	0.900	0.905	0.897
ROTOR MOMENTUM-RISE EFFICIENCY	0.824	0.906	0.917	0.909	0.897
ROTOR HEAD-RISE COEFFICIENT	0.185	0.258	0.297	0.321	0.335
FLOW COEFFICIENT	0.513	0.497	0.474	0.449	0.423
AIRFLOW PER UNIT FRONTAL AREA	54.57	53.03	50.89	48.58	46.24
AIRFLOW PER UNIT ANNULUS AREA	151.58	147.31	141.36	134.95	128.46
AIRFLOW AT ORIFICE	11.06	10.75	10.31	9.85	9.37
AIRFLOW AT ROTOR INLET	11.14	10.82	10.39	9.90	9.41
AIRFLOW AT ROTOR OUTLET	10.98	10.65	10.19	9.59	9.01
AIRFLOW AT STATOR OUTLET	10.69	10.56	10.18	9.69	9.20
ROTATIVE SPEED	10125.1	10093.3	10087.9	10085.0	10100.7
PERCENT OF DESIGN SPEED	110.4	110.1	110.0	110.0	110.1

COMPRESSOR PERFORMANCE

STAGE TOTAL PRESSURE RATIO	1.146	1.215	1.248	1.267	1.277
STAGE TOTAL TEMPERATURE RATIO	1.058	1.070	1.077	1.082	1.087
STAGE ADIABATIC EFFICIENCY	0.682	0.817	0.849	0.848	0.831

(c) 100 Percent of design speed

READING NUMBER	3615	3616	3617	3618	3614
ROTOR TOTAL PRESSURE RATIO	1.143	1.179	1.213	1.226	1.235
STATOR TOTAL PRESSURE RATIO	0.989	0.993	0.992	0.991	0.988
ROTOR TOTAL TEMPERATURE RATIO	1.047	1.054	1.063	1.066	1.070
STATOR TOTAL TEMPERATURE RATIO	1.002	1.001	1.001	1.002	1.001
ROTOR ADIABATIC EFFICIENCY	0.829	0.884	0.905	0.902	0.890
ROTOR MOMENTUM-RISE EFFICIENCY	0.858	0.903	0.903	0.896	0.872
ROTOR HEAD-RISE COEFFICIENT	0.197	0.245	0.289	0.312	0.322
FLOW COEFFICIENT	0.515	0.495	0.462	0.437	0.406
AIRFLOW PER UNIT FRONTAL AREA	50.52	48.83	46.07	43.50	40.80
AIRFLOW PER UNIT ANNULUS AREA	140.34	135.64	127.96	120.84	113.33
AIRFLOW AT ORIFICE	10.24	9.90	9.34	8.82	8.27
AIRFLOW AT ROTOR INLET	10.32	9.98	9.41	8.88	8.32
AIRFLOW AT ROTOR OUTLET	10.15	9.79	9.19	8.59	7.89
AIRFLOW AT STATOR OUTLET	9.93	9.73	9.24	8.76	8.13
ROTATIVE SPEED	9211.7	9216.6	9235.3	9158.3	9181.1
PERCENT OF DESIGN SPEED	100.5	100.5	100.7	99.9	100.1

COMPRESSOR PERFORMANCE

STAGE TOTAL PRESSURE RATIO	1.131	1.171	1.203	1.215	1.220
STAGE TOTAL TEMPERATURE RATIO	1.049	1.056	1.064	1.068	1.071
STAGE ADIABATIC EFFICIENCY	0.732	0.822	0.850	0.842	0.818

TABLE 23. - Continued.

(d) 90 Percent of design speed

READING NUMBER	3625	3624	3623	3622	3621
ROTOR TOTAL PRESSURE RATIO	1.114	1.143	1.164	1.179	1.187
STATOR TOTAL PRESSURE RATIO	0.990	0.994	0.993	0.991	0.992
ROTOR TOTAL TEMPERATURE RATIO	1.037	1.044	1.049	1.053	1.056
STATOR TOTAL TEMPERATURE RATIO	1.002	1.001	1.001	1.001	1.002
ROTOR ADIABATIC EFFICIENCY	0.853	0.895	0.907	0.913	0.896
ROTOR MOMENTUM-RISE EFFICIENCY	0.882	0.912	0.910	0.899	0.877
ROTOR HEAD-RISE COEFFICIENT	0.195	0.244	0.280	0.305	0.317
FLOW COEFFICIENT	0.521	0.494	0.464	0.436	0.404
AIRFLOW PER UNIT FRONTAL AREA	46.40	44.14	41.74	39.42	36.88
AIRFLOW PER UNIT ANNULUS AREA	128.89	122.62	115.94	109.51	102.45
AIRFLOW AT ORIFICE	9.40	8.95	8.46	7.99	7.48
AIRFLOW AT ROTOR INLET	9.47	9.03	8.53	8.06	7.52
AIRFLOW AT ROTOR OUTLET	9.34	8.86	8.36	7.89	7.14
AIRFLOW AT STATOR OUTLET	9.08	8.80	8.37	7.96	7.42
ROTATIVE SPEED	8252.0	8255.2	8245.7	8243.1	8275.3
PERCENT OF DESIGN SPEED	90.0	90.0	89.9	89.9	90.2
COMPRESSOR PERFORMANCE					
STAGE TOTAL PRESSURE RATIO	1.102	1.136	1.156	1.169	1.177
STAGE TOTAL TEMPERATURE RATIO	1.039	1.045	1.050	1.054	1.058
STAGE ADIABATIC EFFICIENCY	0.732	0.823	0.844	0.847	0.822

(e) 80 Percent of design speed

READING NUMBER	3628
ROTOR TOTAL PRESSURE RATIO	1.145
STATOR TOTAL PRESSURE RATIO	0.994
ROTOR TOTAL TEMPERATURE RATIO	1.044
STATOR TOTAL TEMPERATURE RATIO	1.002
ROTOR ADIABATIC EFFICIENCY	0.900
ROTOR MOMENTUM-RISE EFFICIENCY	0.878
ROTOR HEAD-RISE COEFFICIENT	0.313
FLOW COEFFICIENT	0.396
AIRFLOW PER UNIT FRONTAL AREA	32.33
AIRFLOW PER UNIT ANNULUS AREA	89.82
AIRFLOW AT ORIFICE	6.55
AIRFLOW AT ROTOR INLET	6.60
AIRFLOW AT ROTOR OUTLET	6.26
AIRFLOW AT STATOR OUTLET	6.51
ROTATIVE SPEED	7341.0
PERCENT OF DESIGN SPEED	80.1
COMPRESSOR PERFORMANCE	
STAGE TOTAL PRESSURE RATIO	1.138
STAGE TOTAL TEMPERATURE RATIO	1.046
STAGE ADIABATIC EFFICIENCY	0.819

(f) 70 Percent of design speed

READING NUMBER	3636	3635	3634	3633	3632
ROTOR TOTAL PRESSURE RATIO	1.058	1.076	1.090	1.102	1.110
STATOR TOTAL PRESSURE RATIO	0.991	0.995	0.996	0.995	0.994
ROTOR TOTAL TEMPERATURE RATIO	1.019	1.024	1.027	1.031	1.034
STATOR TOTAL TEMPERATURE RATIO	1.001	1.001	1.001	1.001	1.001
ROTOR ADIABATIC EFFICIENCY	0.843	0.897	0.912	0.917	0.904
ROTOR MOMENTUM-RISE EFFICIENCY	0.891	0.922	0.921	0.905	0.879
ROTOR HEAD-RISE COEFFICIENT	0.166	0.215	0.253	0.287	0.310
FLOW COEFFICIENT	0.537	0.505	0.471	0.434	0.395
AIRFLOW PER UNIT FRONTAL AREA	37.86	35.78	33.53	31.16	28.41
AIRFLOW PER UNIT ANNULUS AREA	105.18	99.39	93.14	86.54	78.91
AIRFLOW AT ORIFICE	7.67	7.25	6.80	6.31	5.76
AIRFLOW AT ROTOR INLET	7.75	7.33	6.86	6.37	5.81
AIRFLOW AT ROTOR OUTLET	7.56	7.18	6.71	6.21	5.55
AIRFLOW AT STATOR OUTLET	7.33	7.03	6.68	6.23	5.71
ROTATIVE SPEED	6415.8	6430.6	6420.8	6441.1	6432.9
PERCENT OF DESIGN SPEED	70.0	70.1	70.0	70.2	70.2
COMPRESSOR PERFORMANCE					
STAGE TOTAL PRESSURE RATIO	1.049	1.071	1.085	1.097	1.104
STAGE TOTAL TEMPERATURE RATIO	1.021	1.025	1.028	1.032	1.035
STAGE ADIABATIC EFFICIENCY	0.654	0.783	0.834	0.840	0.821

TABLE 23. - Concluded.

(g) 60 Percent of design speed

READING NUMBER	3639
ROTOR TOTAL PRESSURE RATIO	1.079
STATOR TOTAL PRESSURE RATIO	0.996
ROTOR TOTAL TEMPERATURE RATIO	1.024
STATOR TOTAL TEMPERATURE RATIO	1.001
ROTOR ADIABATIC EFFICIENCY	0.903
ROTOR MOMENTUM-RISE EFFICIENCY	0.879
ROTOR HEAD-RISE COEFFICIENT	0.306
FLOW COEFFICIENT	0.392
AIRFLOW PER UNIT FRONTAL AREA	24.15
AIRFLOW PER UNIT ANNULUS AREA	67.10
AIRFLOW AT ORIFICE	4.90
AIRFLOW AT ROTOT INLET	4.96
AIRFLOW AT ROTOR OUTLET	4.75
AIRFLOW AT STATOR OUTLET	4.92
ROTATIVE SPEED	5504.6
PERCENT OF DESIGN SPEED	60.0

COMPRESSOR PERFORMANCE

STAGE TOTAL PRESSURE RATIO	1.075
STAGE TOTAL TEMPERATURE RATIO	1.026
STAGE ADIABATIC EFFICIENCY	0.815

(h) 50 Percent of design speed

READING NUMBER	3643
ROTOR TOTAL PRESSURE RATIO	1.054
STATOR TOTAL PRESSURE RATIO	0.997
ROTOR TOTAL TEMPERATURE RATIO	1.016
STATOR TOTAL TEMPERATURE RATIO	1.001
ROTOR ADIABATIC EFFICIENCY	0.916
ROTOR MOMENTUM-RISE EFFICIENCY	0.869
ROTOR HEAD-RISE COEFFICIENT	0.300
FLOW COEFFICIENT	0.389
AIRFLOW PER UNIT FRONTAL AREA	19.95
AIRFLOW PER UNIT ANNULUS AREA	55.43
AIRFLOW AT ORIFICE	4.04
AIRFLOW AT ROTOR INLET	4.09
AIRFLOW AT ROTOR OUTLET	3.93
AIRFLOW AT STATOR OUTLET	4.10
ROTATIVE SPEED	4562.9
PERCENT OF DESIGN SPEED	49.8

COMPRESSOR PERFORMANCE

STAGE TOTAL PRESSURE RATIO	1.051
STAGE TOTAL TEMPERATURE RATIO	1.018
STAGE ADIABATIC EFFICIENCY	0.808

TABLE 24. - OVERALL PERFORMANCE OF STAGE 26B-21

(a) 120 Percent of design speed

READING NUMBER	3941	3942	3943	3944	3945
ROTOR TOTAL PRESSURE RATIO	1.400	1.459	1.482	1.490	1.499
STATOR TOTAL PRESSURE RATIO	0.978	0.974	0.970	0.968	0.964
ROTOR TOTAL TEMPERATURE RATIO	1.119	1.126	1.131	1.134	1.136
STATOR TOTAL TEMPERATURE RATIO	0.996	0.997	0.998	0.998	0.999
ROTOR ADIABATIC EFFICIENCY	0.844	0.903	0.910	0.903	0.900
ROTOR MOMENTUM-RISE EFFICIENCY	0.897	0.945	0.954	0.950	0.944
ROTOR HEAD-RISE COEFFICIENT	0.381	0.436	0.455	0.463	0.471
FLOW COEFFICIENT	0.509	0.493	0.474	0.455	0.442
AIRFLOW PER UNIT FRONTAL AREA	57.24	55.58	53.80	52.02	50.75
AIRFLOW PER UNIT ANNULUS AREA	159.01	154.38	149.44	144.50	140.98
AIRFLOW AT ORIFICE	11.60	11.26	10.90	10.54	10.29
AIRFLOW AT ROTOR INLET	11.86	11.53	11.17	10.79	10.53
AIRFLOW AT ROTOR OUTLET	11.92	11.75	11.57	11.18	10.92
AIRFLOW AT STATOR OUTLET	11.15	10.88	10.51	10.19	9.96
ROTATIVE SPEED	11005.3	10981.5	11000.9	10994.2	10997.5
PERCENT OF DESIGN SPEED	120.0	119.8	120.0	119.9	119.9

COMPRESSOR PERFORMANCE

STAGE TOTAL PRESSURE RATIO	1.368	1.422	1.438	1.443	1.445
STAGE TOTAL TEMPERATURE RATIO	1.115	1.123	1.128	1.132	1.135
STAGE ADIABATIC EFFICIENCY	0.816	0.862	0.852	0.837	0.825

(b) 110 Percent of design speed

READING NUMBER	3970	3969	3968
ROTOR TOTAL PRESSURE RATIO	1.311	1.380	1.405
STATOR TOTAL PRESSURE RATIO	0.984	0.979	0.973
ROTOR TOTAL TEMPERATURE RATIO	1.096	1.106	1.113
STATOR TOTAL TEMPERATURE RATIO	0.998	0.998	0.999
ROTOR ADIABATIC EFFICIENCY	0.838	0.906	0.901
ROTOR MOMENTUM-RISE EFFICIENCY	0.874	0.951	0.944
ROTOR HEAD-RISE COEFFICIENT	0.350	0.423	0.450
FLOW COEFFICIENT	0.520	0.477	0.436
AIRFLOW PER UNIT FRONTAL AREA	54.59	50.70	46.80
AIRFLOW PER UNIT ANNULUS AREA	151.64	140.85	130.00
AIRFLOW AT ORIFICE	11.06	10.28	9.49
AIRFLOW AT ROTOR INLET	11.31	10.52	9.73
AIRFLOW AT ROTOR OUTLET	11.26	10.72	10.11
AIRFLOW AT STATOR OUTLET	10.86	9.98	9.22
ROTATIVE SPEED	10160.5	10157.0	10161.8
PERCENT OF DESIGN SPEED	110.8	110.8	110.8

COMPRESSOR PERFORMANCE

STAGE TOTAL PRESSURE RATIO	1.291	1.351	1.367
STAGE TOTAL TEMPERATURE RATIO	1.094	1.104	1.112
STAGE ADIABATIC EFFICIENCY	0.807	0.864	0.834

(c) 100 Percent of design speed

READING NUMBER	3939	3938	3937	3934	3936
ROTOR TOTAL PRESSURE RATIO	1.241	1.280	1.295	1.297	1.309
STATOR TOTAL PRESSURE RATIO	0.987	0.984	0.984	0.986	0.983
ROTOR TOTAL TEMPERATURE RATIO	1.075	1.082	1.084	1.085	1.089
STATOR TOTAL TEMPERATURE RATIO	1.000	0.999	0.999	1.000	1.000
ROTOR ADIABATIC EFFICIENCY	0.846	0.894	0.908	0.903	0.896
ROTOR MOMENTUM-RISE EFFICIENCY	0.876	0.935	0.947	0.950	0.940
ROTOR HEAD-RISE COEFFICIENT	0.328	0.380	0.402	0.411	0.427
FLOW COEFFICIENT	0.536	0.511	0.482	0.453	0.427
AIRFLOW PER UNIT FRONTAL AREA	51.71	49.31	46.79	43.99	41.70
AIRFLOW PER UNIT ANNULUS AREA	143.64	136.98	129.98	122.20	115.83
AIRFLOW AT ORIFICE	10.48	9.99	9.48	8.92	8.45
AIRFLOW AT ROTOR INLET	10.72	10.26	9.73	9.14	8.68
AIRFLOW AT ROTOR OUTLET	10.67	10.29	9.78	9.14	8.70
AIRFLOW AT STATOR OUTLET	10.38	9.81	9.28	8.66	8.24
ROTATIVE SPEED	9239.3	9216.3	9195.4	9119.3	9138.4
PERCENT OF DESIGN SPEED	100.8	100.5	100.3	99.4	99.7

COMPRESSOR PERFORMANCE

STAGE TOTAL PRESSURE RATIO	1.223	1.259	1.274	1.279	1.287
STAGE TOTAL TEMPERATURE RATIO	1.073	1.080	1.083	1.085	1.090
STAGE ADIABATIC EFFICIENCY	0.794	0.851	0.862	0.857	0.833

TABLE 24. - Continued.

(d) 90 Percent of design speed

READING NUMBER	3946	3947	3948	3949	3950
ROTOR TOTAL PRESSURE RATIO	1.168	1.211	1.226	1.239	1.248
STATOR TOTAL PRESSURE RATIO	0.987	0.987	0.988	0.987	0.983
ROTOR TOTAL TEMPERATURE RATIO	1.054	1.062	1.065	1.069	1.073
STATOR TOTAL TEMPERATURE RATIO	1.002	0.999	1.000	1.000	1.000
ROTOR ADIABATIC EFFICIENCY	0.833	0.900	0.914	0.912	0.891
ROTOR MOMENTUM-RISE EFFICIENCY	0.854	0.932	0.952	0.949	0.943
ROTOR HEAD-RISE COEFFICIENT	0.290	0.359	0.388	0.410	0.425
FLOW COEFFICIENT	0.559	0.522	0.481	0.442	0.407
AIRFLOW PER UNIT FRONTAL AREA	48.39	45.67	42.28	39.06	36.24
AIRFLOW PER UNIT ANNULUS AREA	134.42	126.85	117.46	108.49	100.67
AIRFLOW AT ORIFICE	9.81	9.26	8.57	7.92	7.35
AIRFLOW AT ROTOR INLET	10.04	9.49	8.78	8.12	7.56
AIRFLOW AT ROTOR OUTLET	9.94	9.51	8.90	8.19	7.67
AIRFLOW AT STATOR OUTLET	9.80	9.13	8.42	7.69	7.11
ROTATIVE SPEED	8218.0	8247.6	8205.9	8205.2	8228.5
PERCENT OF DESIGN SPEED	89.6	89.9	89.5	89.5	89.7

COMPRESSOR PERFORMANCE

STAGE TOTAL PRESSURE RATIO	1.152	1.195	1.211	1.222	1.227
STAGE TOTAL TEMPERATURE RATIO	1.056	1.062	1.065	1.069	1.073
STAGE ADIABATIC EFFICIENCY	0.737	0.846	0.861	0.855	0.824

(e) 80 Percent of design speed

READING NUMBER	3952
ROTOR TOTAL PRESSURE RATIO	1.197
STATOR TOTAL PRESSURE RATIO	0.983
ROTOR TOTAL TEMPERATURE RATIO	1.058
STATOR TOTAL TEMPERATURE RATIO	0.999
ROTOR ADIABATIC EFFICIENCY	0.906
ROTOR MOMENTUM-RISE EFFICIENCY	0.939
ROTOR HEAD-RISE COEFFICIENT	0.427
FLOW COEFFICIENT	0.401
AIRFLOW PER UNIT FRONTAL AREA	31.94
AIRFLOW PER UNIT ANNULUS AREA	88.73
AIRFLOW AT ORIFICE	6.47
AIRFLOW AT ROTOR INLET	6.66
AIRFLOW AT ROTOR OUTLET	6.87
AIRFLOW AT STATOR OUTLET	6.31
ROTATIVE SPEED	7320.9
PERCENT OF DESIGN SPEED	79.8

COMPRESSOR PERFORMANCE

STAGE TOTAL PRESSURE RATIO	1.177
STAGE TOTAL TEMPERATURE RATIO	1.058
STAGE ADIABATIC EFFICIENCY	0.826

(f) 70 Percent of design speed

READING NUMBER	3960	3959	3956	3955	3954
ROTOR TOTAL PRESSURE RATIO	1.089	1.110	1.128	1.138	1.147
STATOR TOTAL PRESSURE RATIO	0.986	0.991	0.992	0.993	0.989
ROTOR TOTAL TEMPERATURE RATIO	1.030	1.034	1.038	1.040	1.044
STATOR TOTAL TEMPERATURE RATIO	1.002	1.001	1.000	1.001	1.001
ROTOR ADIABATIC EFFICIENCY	0.824	0.896	0.927	0.939	0.913
ROTOR MOMENTUM-RISE EFFICIENCY	0.842	0.909	0.948	0.954	0.940
ROTOR HEAD-RISE COEFFICIENT	0.252	0.309	0.356	0.386	0.413
FLOW COEFFICIENT	0.588	0.554	0.501	0.451	0.394
AIRFLOW PER UNIT FRONTAL AREA	40.43	38.32	35.09	31.60	27.78
AIRFLOW PER UNIT ANNULUS AREA	112.32	106.45	97.48	87.77	77.17
AIRFLOW AT ORIFICE	8.20	7.77	7.11	6.40	5.63
AIRFLOW AT ROTOR INLET	8.42	8.00	7.31	6.60	5.80
AIRFLOW AT ROTOR OUTLET	8.31	7.93	7.27	6.60	5.88
AIRFLOW AT STATOR OUTLET	8.22	7.75	7.01	6.30	5.45
ROTATIVE SPEED	6412.8	6433.3	6458.5	6435.5	6434.4
PERCENT OF DESIGN SPEED	69.9	70.2	70.4	70.2	70.2

COMPRESSOR PERFORMANCE

STAGE TOTAL PRESSURE RATIO	1.073	1.100	1.119	1.129	1.134
STAGE TOTAL TEMPERATURE RATIO	1.032	1.035	1.038	1.041	1.044
STAGE ADIABATIC EFFICIENCY	0.649	0.791	0.855	0.864	0.824

TABLE 24. - Concluded.

(g) 60 Percent of design speed.

READING NUMBER	3962
ROTOR TOTAL PRESSURE RATIO	1.106
STATOR TOTAL PRESSURE RATIO	0.993
ROTOR TOTAL TEMPERATURE RATIO	1.032
STATOR TOTAL TEMPERATURE RATIO	1.001
ROTOR ADIABATIC EFFICIENCY	0.916
ROTOR MOMENTUM-RISE EFFICIENCY	0.936
ROTOR HEAD-RISE COEFFICIENT	0.403
FLOW COEFFICIENT	0.396
AIRFLOW PER UNIT FRONTAL AREA	24.09
AIRFLOW PER UNIT ANNULUS AREA	66.93
AIRFLOW AT ORIFICE	4.88
AIRFLOW AT ROTOR INLET	5.03
AIRFLOW AT ROTOR OUTLET	5.05
AIRFLOW AT STATOR OUTLET	4.79
ROTATIVE SPEED	5528.5
PERCENT OF DESIGN SPEED	60.3

COMPRESSOR PERFORMANCE

STAGE TOTAL PRESSURE RATIO	1.098
STAGE TOTAL TEMPERATURE RATIO	1.032
STAGE ADIABATIC EFFICIENCY	0.834

(h) 50 Percent of design speed.

READING NUMBER	3965
ROTOR TOTAL PRESSURE RATIO	1.069
STATOR TOTAL PRESSURE RATIO	0.997
ROTOR TOTAL TEMPERATURE RATIO	1.021
STATOR TOTAL TEMPERATURE RATIO	1.001
ROTOR ADIABATIC EFFICIENCY	0.916
ROTOR MOMENTUM-RISE EFFICIENCY	0.942
ROTOR HEAD-RISE COEFFICIENT	0.384
FLOW COEFFICIENT	0.419
AIRFLOW PER UNIT FRONTAL AREA	21.02
AIRFLOW PER UNIT ANNULUS AREA	58.39
AIRFLOW AT ORIFICE	4.26
AIRFLOW AT ROTOR INLET	4.41
AIRFLOW AT ROTOR OUTLET	4.37
AIRFLOW AT STATOR OUTLET	4.25
ROTATIVE SPEED	4564.3
PERCENT OF DESIGN SPEED	49.8

COMPRESSOR PERFORMANCE

STAGE TOTAL PRESSURE RATIO	1.065
STAGE TOTAL TEMPERATURE RATIO	1.022
STAGE ADIABATIC EFFICIENCY	0.841

TABLE 25. - OVERALL PERFORMANCE OF STAGE 26D-21

(a) 120 Percent of design speed

READING NUMBER	4428	4429	4430	4431	4434	4427
ROTOR TOTAL PRESSURE RATIO	1.270	1.308	1.338	1.377	1.405	1.427
STATOR TOTAL PRESSURE RATIO	0.953	0.971	0.980	0.985	0.986	0.983
ROTOR TOTAL TEMPERATURE RATIO	1.088	1.095	1.101	1.108	1.115	1.123
STATOR TOTAL TEMPERATURE RATIO	0.999	0.999	1.000	1.000	0.999	0.998
ROTOR ADIABATIC EFFICIENCY	0.799	0.836	0.860	0.889	0.886	0.870
ROTOR MOMENTUM-RISE EFFICIENCY	0.822	0.853	0.896	0.927	0.920	0.909
ROTOR HEAD-RISE COEFFICIENT	0.260	0.295	0.322	0.359	0.384	0.405
FLOW COEFFICIENT	0.585	0.573	0.559	0.533	0.502	0.472
AIRFLOW PER UNIT FRONTAL AREA	64.45	63.52	62.42	59.91	57.09	54.32
AIRFLOW PER UNIT ANNULUS AREA	179.03	176.44	173.38	166.43	158.57	150.89
AIRFLOW AT ORIFICE	13.06	12.87	12.65	12.14	11.57	11.01
AIRFLOW AT ROTOR INLET	13.18	12.98	12.76	12.27	11.70	11.14
AIRFLOW AT ROTOR OUTLET	13.08	12.77	12.50	11.95	11.51	10.97
AIRFLOW AT STATOR OUTLET	12.85	12.60	12.35	11.80	11.22	10.71
ROTATIVE SPEED	11005.9	11014.0	11024.3	10997.7	11007.6	11007.9
PERCENT OF DESIGN SPEED	120.0	120.1	120.2	119.9	120.0	120.0
COMPRESSOR PERFORMANCE						
STAGE TOTAL PRESSURE RATIO	1.210	1.270	1.312	1.367	1.385	1.402
STAGE TOTAL TEMPERATURE RATIO	1.087	1.094	1.101	1.108	1.114	1.121
STAGE ADIABATIC EFFICIENCY	0.645	0.752	0.801	0.846	0.856	0.837

(b) 110 Percent of design speed

READING NUMBER	4416	4414	4417	4418	4412
ROTOR TOTAL PRESSURE RATIO	1.254	1.250	1.296	1.339	1.353
STATOR TOTAL PRESSURE RATIO	0.955	0.956	0.976	0.978	0.979
ROTOR TOTAL TEMPERATURE RATIO	1.074	1.073	1.083	1.094	1.102
STATOR TOTAL TEMPERATURE RATIO	1.000	1.000	1.000	0.997	0.997
ROTOR ADIABATIC EFFICIENCY	0.898	0.901	0.926	0.920	0.887
ROTOR MOMENTUM-RISE EFFICIENCY	0.905	0.907	0.937	0.939	0.928
ROTOR HEAD-RISE COEFFICIENT	0.288	0.288	0.334	0.382	0.399
FLOW COEFFICIENT	0.609	0.609	0.567	0.505	0.455
AIRFLOW PER UNIT FRONTAL AREA	62.28	61.90	58.86	53.53	48.98
AIRFLOW PER UNIT ANNULUS AREA	173.01	171.94	163.51	148.69	136.05
AIRFLOW AT ORIFICE	12.62	12.55	11.93	10.85	9.93
AIRFLOW AT ROTOR INLET	12.73	12.66	12.05	10.97	10.03
AIRFLOW AT ROTOR OUTLET	12.64	12.57	12.04	11.11	10.20
AIRFLOW AT STATOR OUTLET	12.41	12.35	11.64	10.57	9.70
ROTATIVE SPEED	10090.6	10010.5	10102.7	10097.7	10094.6
PERCENT OF DESIGN SPEED	110.0	109.2	110.2	110.1	110.1
COMPRESSOR PERFORMANCE					
STAGE TOTAL PRESSURE RATIO	1.197	1.195	1.265	1.309	1.325
STAGE TOTAL TEMPERATURE RATIO	1.074	1.073	1.083	1.091	1.099
STAGE ADIABATIC EFFICIENCY	0.709	0.711	0.842	0.876	0.850

(c) 100 Percent of design speed

READING NUMBER	4401	4402	4407	4408	4409	4400
ROTOR TOTAL PRESSURE RATIO	1.191	1.213	1.234	1.248	1.260	1.263
STATOR TOTAL PRESSURE RATIO	0.952	0.969	0.976	0.983	0.986	0.988
ROTOR TOTAL TEMPERATURE RATIO	1.056	1.061	1.066	1.070	1.075	1.080
STATOR TOTAL TEMPERATURE RATIO	1.001	1.001	1.000	0.999	0.999	1.000
ROTOR ADIABATIC EFFICIENCY	0.909	0.925	0.944	0.928	0.907	0.860
ROTOR MOMENTUM-RISE EFFICIENCY	0.906	0.930	0.950	0.938	0.938	0.889
ROTOR HEAD-RISE COEFFICIENT	0.262	0.292	0.321	0.341	0.358	0.361
FLOW COEFFICIENT	0.616	0.593	0.562	0.519	0.478	0.429
AIRFLOW PER UNIT FRONTAL AREA	58.37	56.55	53.96	50.51	46.92	42.63
AIRFLOW PER UNIT ANNULUS AREA	162.13	157.07	149.89	140.30	130.34	118.42
AIRFLOW AT ORIFICE	11.83	11.46	10.94	10.24	9.51	8.64
AIRFLOW AT ROTOR INLET	11.94	11.58	11.06	10.35	9.62	8.76
AIRFLOW AT ROTOR OUTLET	11.74	11.44	11.11	10.34	9.59	8.63
AIRFLOW AT STATOR OUTLET	11.65	11.24	10.73	10.00	9.26	8.43
ROTATIVE SPEED	9190.8	9193.1	9172.9	9167.8	9161.6	9186.5
PERCENT OF DESIGN SPEED	100.2	100.3	100.0	100.0	99.9	100.2
COMPRESSOR PERFORMANCE						
STAGE TOTAL PRESSURE RATIO	1.134	1.175	1.204	1.227	1.242	1.248
STAGE TOTAL TEMPERATURE RATIO	1.057	1.062	1.066	1.070	1.074	1.080
STAGE ADIABATIC EFFICIENCY	0.637	0.762	0.828	0.861	0.859	0.820

TABLE 25. - Continued.

(d) 90 Percent of design speed

READING NUMBER	4449	4450	4451	4452	4453	4426	4422
ROTOR TOTAL PRESSURE RATIO	1.153	1.169	1.183	1.195	1.209	1.218	1.222
STATOR TOTAL PRESSURE RATIO	0.958	0.973	0.985	0.991	0.989	0.985	0.984
ROTOR TOTAL TEMPERATURE RATIO	1.045	1.049	1.053	1.057	1.063	1.068	1.068
STATOR TOTAL TEMPERATURE RATIO	1.001	1.001	1.000	1.000	1.000	0.998	0.998
ROTOR ADIABATIC EFFICIENCY	0.920	0.935	0.929	0.913	0.886	0.857	0.872
ROTOR MOMENTUM-RISE EFFICIENCY	0.917	0.929	0.925	0.916	0.907	0.894	0.900
ROTOR HEAD-RISE COEFFICIENT	0.260	0.286	0.312	0.331	0.353	0.374	0.377
FLOW COEFFICIENT	0.613	0.583	0.538	0.493	0.455	0.424	0.420
AIRFLOW PER UNIT FRONTAL AREA	53.09	51.01	47.45	43.99	40.81	38.07	37.97
AIRFLOW PER UNIT ANNULUS AREA	147.48	141.69	131.80	122.21	113.36	105.74	105.49
AIRFLOW AT ORIFICE	10.76	10.34	9.62	8.92	8.27	7.72	7.70
AIRFLOW AT ROTOR INLET	10.88	10.46	9.74	9.02	8.39	7.83	7.80
AIRFLOW AT ROTOR OUTLET	10.75	10.31	9.58	8.81	8.19	7.80	7.87
AIRFLOW AT STATOR OUTLET	10.62	10.15	9.45	8.72	8.09	7.53	7.61
ROTATIVE SPEED	8250.6	8268.8	8256.1	8259.6	8271.9	8232.6	8272.1
PERCENT OF DESIGN SPEED	90.0	90.2	90.0	90.1	90.2	89.8	90.2

COMPRESSOR PERFORMANCE

STAGE TOTAL PRESSURE RATIO	1.104	1.137	1.166	1.184	1.196	1.200	1.202
STAGE TOTAL TEMPERATURE RATIO	1.046	1.049	1.053	1.058	1.062	1.066	1.066
STAGE ADIABATIC EFFICIENCY	0.628	0.755	0.837	0.858	0.842	0.816	0.819

(e) 80 Percent of design speed

READING NUMBER	4437
ROTOR TOTAL PRESSURE RATIO	1.162
STATOR TOTAL PRESSURE RATIO	0.993
ROTOR TOTAL TEMPERATURE RATIO	1.050
STATOR TOTAL TEMPERATURE RATIO	1.000
ROTOR ADIABATIC EFFICIENCY	0.867
ROTOR MOMENTUM-RISE EFFICIENCY	0.895
ROTOR HEAD-RISE COEFFICIENT	0.353
FLOW COEFFICIENT	0.419
AIRFLOW PER UNIT FRONTAL AREA	33.62
AIRFLOW PER UNIT ANNULUS AREA	93.38
AIRFLOW AT ORIFICE	6.81
AIRFLOW AT ROTOR INLET	6.92
AIRFLOW AT ROTOR OUTLET	6.81
AIRFLOW AT STATOR OUTLET	6.65
ROTATIVE SPEED	7299.1
PERCENT OF DESIGN SPEED	79.6

COMPRESSOR PERFORMANCE

STAGE TOTAL PRESSURE RATIO	1.153
STAGE TOTAL TEMPERATURE RATIO	1.051
STAGE ADIABATIC EFFICIENCY	0.819

(f) 70 Percent of design speed

READING NUMBER	4441	4440	4442	4443	4439
ROTOR TOTAL PRESSURE RATIO	1.091	1.100	1.109	1.118	1.126
STATOR TOTAL PRESSURE RATIO	0.977	0.987	0.993	0.994	0.993
ROTOR TOTAL TEMPERATURE RATIO	1.027	1.030	1.032	1.036	1.040
STATOR TOTAL TEMPERATURE RATIO	1.001	1.001	1.001	1.001	1.000
ROTOR ADIABATIC EFFICIENCY	0.931	0.933	0.930	0.911	0.863
ROTOR MOMENTUM-RISE EFFICIENCY	0.942	0.941	0.928	0.921	0.888
ROTOR HEAD-RISE COEFFICIENT	0.257	0.282	0.306	0.332	0.353
FLOW COEFFICIENT	0.593	0.554	0.509	0.460	0.404
AIRFLOW PER UNIT FRONTAL AREA	41.31	38.79	35.80	32.54	28.87
AIRFLOW PER UNIT ANNULUS AREA	114.75	107.75	99.44	90.40	80.20
AIRFLOW AT ORIFICE	8.37	7.86	7.26	6.60	5.85
AIRFLOW AT ROTOR INLET	8.49	7.98	7.38	6.71	5.96
AIRFLOW AT ROTOR OUTLET	8.40	7.88	7.23	6.65	5.88
AIRFLOW AT STATOR OUTLET	8.28	7.74	7.13	6.48	5.73
ROTATIVE SPEED	6421.4	6421.8	6426.4	6424.0	6455.4
PERCENT OF DESIGN SPEED	70.0	70.0	70.1	70.1	70.4

COMPRESSOR PERFORMANCE

STAGE TOTAL PRESSURE RATIO	1.066	1.085	1.100	1.111	1.119
STAGE TOTAL TEMPERATURE RATIO	1.028	1.031	1.033	1.036	1.040
STAGE ADIABATIC EFFICIENCY	0.655	0.772	0.834	0.847	0.807

TABLE 25. - Concluded.

(g) 60 Percent of design speed

READING NUMBER	4445
ROTOR TOTAL PRESSURE RATIO	1.090
STATOR TOTAL PRESSURE RATIO	0.994
ROTOR TOTAL TEMPERATURE RATIO	1.029
STATOR TOTAL TEMPERATURE RATIO	1.000
ROTOR ADIABATIC EFFICIENCY	0.875
ROTOR MOMENTUM-RISE EFFICIENCY	0.886
ROTOR HEAD-RISE COEFFICIENT	0.348
FLOW COEFFICIENT	0.402
AIRFLOW PER UNIT FRONTAL AREA	24.53
AIRFLOW PER UNIT ANNULUS AREA	68.13
AIRFLOW AT ORIFICE	4.97
AIRFLOW AT ROTOR INLET	5.07
AIRFLOW AT ROTOR OUTLET	5.01
AIRFLOW AT STATOR OUTLET	4.89
ROTATIVE SPEED	5492.6
PERCENT OF DESIGN SPEED	59.9

COMPRESSOR PERFORMANCE

STAGE TOTAL PRESSURE RATIO	1.084
STAGE TOTAL TEMPERATURE RATIO	1.029
STAGE ADIABATIC EFFICIENCY	0.804

(h) 50 Percent of design speed

READING NUMBER	4448
ROTOR TOTAL PRESSURE RATIO	1.062
STATOR TOTAL PRESSURE RATIO	0.996
ROTOR TOTAL TEMPERATURE RATIO	1.020
STATOR TOTAL TEMPERATURE RATIO	1.001
ROTOR ADIABATIC EFFICIENCY	0.883
ROTOR MOMENTUM-RISE EFFICIENCY	0.889
ROTOR HEAD-RISE COEFFICIENT	0.339
FLOW COEFFICIENT	0.405
AIRFLOW PER UNIT FRONTAL AREA	20.76
AIRFLOW PER UNIT ANNULUS AREA	57.68
AIRFLOW AT ORIFICE	4.21
AIRFLOW AT ROTOR INLET	4.31
AIRFLOW AT ROTOR OUTLET	4.25
AIRFLOW AT STATOR OUTLET	4.18
ROTATIVE SPEED	4604.5
PERCENT OF DESIGN SPEED	50.2

COMPRESSOR PERFORMANCE

STAGE TOTAL PRESSURE RATIO	1.058
STAGE TOTAL TEMPERATURE RATIO	1.020
STAGE ADIABATIC EFFICIENCY	0.796

TABLE 26. - OVERALL PERFORMANCE OF STAGE 26D-21D

(a) 120 Percent of design speed

READING NUMBER	0122	0125	0126	0127	0129	0121
ROTOR TOTAL PRESSURE RATIO	1.215	1.277	1.325	1.365	1.406	1.425
STATOR TOTAL PRESSURE RATIO	0.972	0.981	0.986	0.985	0.977	0.970
ROTOR TOTAL TEMPERATURE RATIO	1.076	1.088	1.097	1.104	1.113	1.122
STATOR TOTAL TEMPERATURE RATIO	1.000	0.998	0.999	1.000	0.998	0.997
ROTOR ADIABATIC EFFICIENCY	0.750	0.822	0.861	0.891	0.904	0.872
ROTOR MOMENTUM-RISE EFFICIENCY	0.785	0.853	0.896	0.914	0.931	0.867
ROTOR HEAD-RISE COEFFICIENT	0.208	0.266	0.310	0.346	0.386	0.405
FLOW COEFFICIENT	0.593	0.584	0.567	0.546	0.508	0.470
AIRFLOW PER UNIT FRONTAL AREA	65.19	64.47	63.41	61.47	58.20	53.95
AIRFLOW PER UNIT ANNULUS AREA	181.08	179.10	176.13	170.76	161.67	149.86
AIRFLOW AT ORIFICE	13.21	13.07	12.85	12.46	11.80	10.93
AIRFLOW AT ROTOR INLET	13.32	13.16	12.90	12.54	11.81	11.08
AIRFLOW AT ROTOR OUTLET	13.17	13.46	13.16	12.72	12.10	11.40
AIRFLOW AT STATOR OUTLET	12.96	12.97	12.73	12.24	11.47	10.37
ROTATIVE SPEED	11011.3	10994.7	11018.3	11029.4	10987.9	10990.0
PERCENT OF DESIGN SPEED	120.1	119.9	120.2	120.3	119.8	119.8

COMPRESSOR PERFORMANCE

STAGE TOTAL PRESSURE RATIO	1.180	1.252	1.306	1.345	1.374	1.382
STAGE TOTAL TEMPERATURE RATIO	1.076	1.086	1.096	1.104	1.111	1.119
STAGE ADIABATIC EFFICIENCY	0.635	0.770	0.829	0.849	0.855	0.816

(b) 110 Percent of design speed

READING NUMBER	0117	0118	0116
ROTOR TOTAL PRESSURE RATIO	1.202	1.308	1.341
STATOR TOTAL PRESSURE RATIO	0.976	0.988	0.975
ROTOR TOTAL TEMPERATURE RATIO	1.065	1.087	1.098
STATOR TOTAL TEMPERATURE RATIO	1.000	1.000	0.997
ROTOR ADIABATIC EFFICIENCY	0.830	0.917	0.889
ROTOR MOMENTUM-RISE EFFICIENCY	0.871	0.911	0.876
ROTOR HEAD-RISE COEFFICIENT	0.232	0.348	0.389
FLOW COEFFICIENT	0.626	0.535	0.465
AIRFLOW PER UNIT FRONTAL AREA	63.50	56.09	49.57
AIRFLOW PER UNIT ANNULUS AREA	176.39	155.82	137.70
AIRFLOW AT ORIFICE	12.87	11.37	10.05
AIRFLOW AT ROTOR INLET	12.98	11.51	10.18
AIRFLOW AT ROTOR OUTLET	12.67	11.49	10.52
AIRFLOW AT STATOR OUTLET	12.62	11.13	9.66
ROTATIVE SPEED	10072.1	10094.9	10050.2
PERCENT OF DESIGN SPEED	109.8	110.1	109.6

COMPRESSOR PERFORMANCE

STAGE TOTAL PRESSURE RATIO	1.173	1.292	1.307
STAGE TOTAL TEMPERATURE RATIO	1.065	1.087	1.095
STAGE ADIABATIC EFFICIENCY	0.715	0.876	0.833

(c) 100 Percent of design speed

READING NUMBER	0084	0083	0082	0081	0080	0079
ROTOR TOTAL PRESSURE RATIO	1.170	1.208	1.232	1.243	1.260	1.269
STATOR TOTAL PRESSURE RATIO	0.978	0.985	0.989	0.990	0.985	0.980
ROTOR TOTAL TEMPERATURE RATIO	1.052	1.060	1.066	1.069	1.075	1.079
STATOR TOTAL TEMPERATURE RATIO	1.001	1.001	1.000	1.000	0.999	0.999
ROTOR ADIABATIC EFFICIENCY	0.877	0.924	0.934	0.929	0.915	0.886
ROTOR MOMENTUM-RISE EFFICIENCY	0.884	0.938	0.957	0.948	0.934	0.902
ROTOR HEAD-RISE COEFFICIENT	0.233	0.286	0.319	0.335	0.357	0.370
FLOW COEFFICIENT	0.642	0.617	0.576	0.537	0.494	0.448
AIRFLOW PER UNIT FRONTAL AREA	60.16	58.21	54.80	51.60	48.06	43.93
AIRFLOW PER UNIT ANNULUS AREA	167.12	161.70	152.22	143.35	133.49	122.03
AIRFLOW AT ORIFICE	12.19	11.80	11.11	10.46	9.74	8.90
AIRFLOW AT ROTOR INLET	12.34	11.94	11.28	10.64	9.92	9.09
AIRFLOW AT ROTOR OUTLET	12.31	11.93	11.27	10.62	9.98	9.16
AIRFLOW AT STATOR OUTLET	11.98	11.60	10.94	10.32	9.54	8.61
ROTATIVE SPEED	9188.9	9169.9	9161.7	9154.9	9168.3	9165.2
PERCENT OF DESIGN SPEED	100.2	100.0	99.9	99.8	100.0	99.9

COMPRESSOR PERFORMANCE

STAGE TOTAL PRESSURE RATIO	1.144	1.190	1.218	1.230	1.241	1.244
STAGE TOTAL TEMPERATURE RATIO	1.053	1.060	1.066	1.069	1.074	1.079
STAGE ADIABATIC EFFICIENCY	0.738	0.843	0.881	0.884	0.864	0.818

TABLE 26. - Continued.

(d) 90 Percent of design speed

READING NUMBER	0093	0096	0088	0087	0086
ROTOR TOTAL PRESSURE RATIO	1.134	1.169	1.185	1.201	1.214
STATOR TOTAL PRESSURE RATIO	0.980	0.990	0.990	0.991	0.985
ROTOR TOTAL TEMPERATURE RATIO	1.041	1.048	1.053	1.058	1.064
STATOR TOTAL TEMPERATURE RATIO	1.001	1.001	1.000	1.000	1.000
ROTOR ADIABATIC EFFICIENCY	0.898	0.949	0.939	0.924	0.891
ROTOR MOMENTUM-RISE EFFICIENCY	0.901	0.959	0.953	0.939	0.899
ROTOR HEAD-RISE COEFFICIENT	0.229	0.288	0.315	0.342	0.362
FLOW COEFFICIENT	0.642	0.594	0.550	0.497	0.446
AIRFLOW PER UNIT FRONTAL AREA	55.23	51.74	48.06	43.96	39.80
AIRFLOW PER UNIT ANNULUS AREA	153.41	143.72	133.49	122.11	110.56
AIRFLOW AT ORIFICE	11.19	10.49	9.74	8.91	8.07
AIRFLOW AT ROTOR INLET	11.31	10.61	9.91	9.09	8.25
AIRFLOW AT ROTOR OUTLET	11.29	10.64	9.90	9.09	8.17
AIRFLOW AT STATOR OUTLET	11.04	10.36	9.55	8.78	7.86
ROTATIVE SPEED	8236.5	8248.6	8229.7	8260.0	8276.9
PERCENT OF DESIGN SPEED	89.8	90.0	89.7	90.1	90.3
COMPRESSOR PERFORMANCE					
STAGE TOTAL PRESSURE RATIO	1.111	1.157	1.173	1.191	1.196
STAGE TOTAL TEMPERATURE RATIO	1.042	1.049	1.053	1.058	1.064
STAGE ADIABATIC EFFICIENCY	0.738	0.870	0.882	0.875	0.826

(e) 80 Percent of design speed

READING NUMBER	0105
ROTOR TOTAL PRESSURE RATIO	1.167
STATOR TOTAL PRESSURE RATIO	0.987
ROTOR TOTAL TEMPERATURE RATIO	1.050
STATOR TOTAL TEMPERATURE RATIO	1.000
ROTOR ADIABATIC EFFICIENCY	0.899
ROTOR MOMENTUM-RISE EFFICIENCY	0.887
ROTOR HEAD-RISE COEFFICIENT	0.358
FLOW COEFFICIENT	0.424
AIRFLOW PER UNIT FRONTAL AREA	34.33
AIRFLOW PER UNIT ANNULUS AREA	95.37
AIRFLOW AT ORIFICE	6.96
AIRFLOW AT ROTOR INLET	7.06
AIRFLOW AT ROTOR OUTLET	6.98
AIRFLOW AT STATOR OUTLET	6.77
ROTATIVE SPEED	7361.3
PERCENT OF DESIGN SPEED	80.3
COMPRESSOR PERFORMANCE	
STAGE TOTAL PRESSURE RATIO	1.152
STAGE TOTAL TEMPERATURE RATIO	1.051
STAGE ADIABATIC EFFICIENCY	0.818

(f) 70 Percent of design speed

READING NUMBER	0099	0100	0101	0102	0130	0103	0098
ROTOR TOTAL PRESSURE RATIO	1.080	1.096	1.105	1.115	1.120	1.122	1.127
STATOR TOTAL PRESSURE RATIO	0.988	0.992	0.995	0.994	0.996	0.993	0.989
ROTOR TOTAL TEMPERATURE RATIO	1.024	1.028	1.031	1.033	1.035	1.036	1.039
STATOR TOTAL TEMPERATURE RATIO	1.001	1.001	1.001	1.001	1.001	1.001	1.000
ROTOR ADIABATIC EFFICIENCY	0.922	0.948	0.945	0.945	0.942	0.918	0.895
ROTOR MOMENTUM-RISE EFFICIENCY	0.937	0.959	0.950	0.947	0.944	0.919	0.887
ROTOR HEAD-RISE COEFFICIENT	0.226	0.269	0.292	0.319	0.338	0.341	0.359
FLOW COEFFICIENT	0.634	0.589	0.547	0.504	0.458	0.448	0.405
AIRFLOW PER UNIT FRONTAL AREA	43.99	41.25	38.52	35.78	32.41	31.93	28.83
AIRFLOW PER UNIT ANNULUS AREA	122.20	114.59	106.99	99.38	90.02	88.69	80.07
AIRFLOW AT ORIFICE	8.92	8.36	7.81	7.25	6.57	6.47	5.84
AIRFLOW AT ROTOR INLET	9.03	8.47	7.93	7.35	6.67	6.57	5.94
AIRFLOW AT ROTOR OUTLET	8.98	8.44	7.85	7.35	6.79	6.56	5.94
AIRFLOW AT STATOR OUTLET	8.77	8.25	7.70	7.13	6.56	6.34	5.65
ROTATIVE SPEED	6423.0	6443.6	6455.7	6463.1	6415.9	6450.9	6426.4
PERCENT OF DESIGN SPEED	70.0	70.3	70.4	70.5	70.0	70.3	70.1
COMPRESSOR PERFORMANCE							
STAGE TOTAL PRESSURE RATIO	1.067	1.088	1.099	1.108	1.115	1.114	1.115
STAGE TOTAL TEMPERATURE RATIO	1.025	1.029	1.031	1.034	1.036	1.037	1.039
STAGE ADIABATIC EFFICIENCY	0.750	0.844	0.869	0.879	0.879	0.844	0.800

TABLE 26. - Concluded.

(g) 60 Percent of design speed

READING NUMBER	0108
ROTOR TOTAL PRESSURE RATIO	1.088
STATOR TOTAL PRESSURE RATIO	0.994
ROTOR TOTAL TEMPERATURE RATIO	1.027
STATOR TOTAL TEMPERATURE RATIO	1.001
ROTOR ADIABATIC EFFICIENCY	0.909
ROTOR MOMENTUM-RISE EFFICIENCY	0.902
ROTOR HEAD-RISE COEFFICIENT	0.345
FLOW COEFFICIENT	0.414
AIRFLOW PER UNIT FRONTAL AREA	25.28
AIRFLOW PER UNIT ANNULUS AREA	70.21
AIRFLOW AT ORIFICE	5.12
AIRFLOW AT ROTOR INLET	5.19
AIRFLOW AT ROTOR OUTLET	5.11
AIRFLOW AT STATOR OUTLET	5.00
ROTATIVE SPEED	5462.2
PERCENT OF DESIGN SPEED	59.6
COMPRESSOR PERFORMANCE	
STAGE TOTAL PRESSURE RATIO	1.082
STAGE TOTAL TEMPERATURE RATIO	1.028
STAGE ADIABATIC EFFICIENCY	0.822

(h) 50 Percent of design speed

READING NUMBER	0114
ROTOR TOTAL PRESSURE RATIO	1.063
STATOR TOTAL PRESSURE RATIO	0.995
ROTOR TOTAL TEMPERATURE RATIO	1.019
STATOR TOTAL TEMPERATURE RATIO	1.001
ROTOR ADIABATIC EFFICIENCY	0.911
ROTOR MOMENTUM-RISE EFFICIENCY	0.858
ROTOR HEAD-RISE COEFFICIENT	0.343
FLOW COEFFICIENT	0.403
AIRFLOW PER UNIT FRONTAL AREA	20.86
AIRFLOW PER UNIT ANNULUS AREA	57.94
AIRFLOW AT ORIFICE	4.23
AIRFLOW AT ROTOR INLET	4.31
AIRFLOW AT ROTOR OUTLET	4.32
AIRFLOW AT STATOR OUTLET	4.09
ROTATIVE SPEED	4641.7
PERCENT OF DESIGN SPEED	50.6
COMPRESSOR PERFORMANCE	
STAGE TOTAL PRESSURE RATIO	1.058
STAGE TOTAL TEMPERATURE RATIO	1.021
STAGE ADIABATIC EFFICIENCY	0.786

TABLE 27. - OVERALL PERFORMANCE OF STAGE 27A-21

(a) 120 Percent of design speed

READING NUMBER	3902	3914	3903	3904	3900	3913
ROTOR TOTAL PRESSURE RATIO	1.372	1.402	1.445	1.476	1.500	1.536
STATOR TOTAL PRESSURE RATIO	0.992	0.988	0.988	0.982	0.978	0.961
ROTOR TOTAL TEMPERATURE RATIO	1.113	1.117	1.123	1.128	1.133	1.144
STATOR TOTAL TEMPERATURE RATIO	1.000	0.999	0.998	0.997	0.997	0.997
ROTOR ADIABATIC EFFICIENCY	0.840	0.863	0.902	0.918	0.921	0.909
ROTOR MOMENTUM-RISE EFFICIENCY	0.858	0.909	0.939	0.956	0.957	0.971
ROTOR HEAD-RISE COEFFICIENT	0.357	0.382	0.423	0.450	0.472	0.505
FLOW COEFFICIENT	0.532	0.531	0.524	0.502	0.482	0.438
AIRFLOW PER UNIT FRONTAL AREA	59.18	59.18	58.46	56.50	54.67	50.49
AIRFLOW PER UNIT ANNULUS AREA	164.38	164.38	162.40	156.95	151.85	140.24
AIRFLOW AT ORIFICE	11.99	11.99	11.85	11.45	11.08	10.23
AIRFLOW AT ROTOR INLET	12.26	12.27	12.11	11.70	11.32	10.46
AIRFLOW AT ROTOR OUTLET	11.63	12.01	11.63	11.28	11.07	10.93
AIRFLOW AT STATOR OUTLET	12.18	11.83	11.83	11.33	11.28	9.73
ROTATIVE SPEED	10975.5	11011.7	10982.2	10977.8	10988.5	11001.7
PERCENT OF DESIGN SPEED	119.7	120.1	119.8	119.7	119.8	120.0

COMPRESSOR PERFORMANCE

STAGE TOTAL PRESSURE RATIO	1.361	1.385	1.427	1.449	1.467	1.477
STAGE TOTAL TEMPERATURE RATIO	1.113	1.117	1.120	1.125	1.130	1.140
STAGE ADIABATIC EFFICIENCY	0.816	0.835	0.889	0.898	0.889	0.842

(b) 114 Percent of design speed

READING NUMBER	3898	3899	3897	3911
ROTOR TOTAL PRESSURE RATIO	1.358	1.404	1.418	1.465
STATOR TOTAL PRESSURE RATIO	0.986	0.984	0.990	0.970
ROTOR TOTAL TEMPERATURE RATIO	1.105	1.111	1.115	1.127
STATOR TOTAL TEMPERATURE RATIO	0.998	0.997	0.999	0.998
ROTOR ADIABATIC EFFICIENCY	0.872	0.917	0.916	0.906
ROTOR MOMENTUM-RISE EFFICIENCY	0.886	0.941	0.962	0.961
ROTOR HEAD-RISE COEFFICIENT	0.377	0.424	0.439	0.487
FLOW COEFFICIENT	0.538	0.519	0.489	0.432
AIRFLOW PER UNIT FRONTAL AREA	57.45	55.83	53.14	47.74
AIRFLOW PER UNIT ANNULUS AREA	159.58	155.09	147.61	132.62
AIRFLOW AT ORIFICE	11.64	11.32	10.77	9.68
AIRFLOW AT ROTOR INLET	11.91	11.56	11.00	9.90
AIRFLOW AT ROTOR OUTLET	11.58	11.29	10.59	10.15
AIRFLOW AT STATOR OUTLET	11.80	11.39	10.69	9.30
ROTATIVE SPEED	10463.0	10456.9	10449.6	10450.3
PERCENT OF DESIGN SPEED	114.1	114.0	114.0	114.0

COMPRESSOR PERFORMANCE

STAGE TOTAL PRESSURE RATIO	1.338	1.382	1.404	1.420
STAGE TOTAL TEMPERATURE RATIO	1.103	1.108	1.113	1.125
STAGE ADIABATIC EFFICIENCY	0.847	0.897	0.897	0.845

(c) 100 Percent of design speed

READING NUMBER	3896	3895	3894	3893	3909
ROTOR TOTAL PRESSURE RATIO	1.232	1.273	1.302	1.331	1.350
STATOR TOTAL PRESSURE RATIO	0.988	0.995	0.994	0.982	0.971
ROTOR TOTAL TEMPERATURE RATIO	1.072	1.078	1.085	1.092	1.100
STATOR TOTAL TEMPERATURE RATIO	1.000	1.000	1.000	0.997	0.996
ROTOR ADIABATIC EFFICIENCY	0.857	0.911	0.921	0.923	0.895
ROTOR MOMENTUM-RISE EFFICIENCY	0.856	0.927	0.953	0.951	0.954
ROTOR HEAD-RISE COEFFICIENT	0.319	0.375	0.413	0.452	0.479
FLOW COEFFICIENT	0.563	0.532	0.488	0.451	0.413
AIRFLOW PER UNIT FRONTAL AREA	53.54	50.93	47.34	44.23	40.76
AIRFLOW PER UNIT ANNULUS AREA	148.73	141.46	131.51	122.85	113.23
AIRFLOW AT ORIFICE	10.85	10.32	9.60	8.96	8.26
AIRFLOW AT ROTOR INLET	11.09	10.58	9.82	9.16	8.46
AIRFLOW AT ROTOR OUTLET	10.66	10.11	9.37	9.02	8.91
AIRFLOW AT STATOR OUTLET	11.01	10.50	9.74	9.04	7.99
ROTATIVE SPEED	9174.0	9167.4	9168.7	9178.2	9174.0
PERCENT OF DESIGN SPEED	100.0	100.0	100.0	100.1	100.0

COMPRESSOR PERFORMANCE

STAGE TOTAL PRESSURE RATIO	1.217	1.266	1.293	1.307	1.310
STAGE TOTAL TEMPERATURE RATIO	1.072	1.078	1.085	1.089	1.095
STAGE ADIABATIC EFFICIENCY	0.804	0.891	0.902	0.888	0.841

TABLE 27. - Continued.

(d) 90 Percent of design speed

READING NUMBER	3906	3918	3905	3917	3916
ROTOR TOTAL PRESSURE RATIO	1.173	1.220	1.242	1.250	1.267
STATOR TOTAL PRESSURE RATIO	0.986	0.986	0.992	0.993	0.984
ROTOR TOTAL TEMPERATURE RATIO	1.054	1.063	1.069	1.072	1.078
STATOR TOTAL TEMPERATURE RATIO	1.001	0.999	0.999	1.000	0.999
ROTOR ADIABATIC EFFICIENCY	0.863	0.923	0.923	0.911	0.898
ROTOR MOMENTUM-RISE EFFICIENCY	0.859	0.944	0.957	0.977	0.957
ROTOR HEAD-RISE COEFFICIENT	0.297	0.373	0.413	0.423	0.452
FLOW COEFFICIENT	0.579	0.533	0.478	0.445	0.406
AIRFLOW PER UNIT FRONTAL AREA	49.96	46.69	42.07	39.67	36.30
AIRFLOW PER UNIT ANNULUS AREA	138.79	129.70	116.86	110.19	100.84
AIRFLOW AT ORIFICE	10.13	9.46	8.53	8.04	7.36
AIRFLOW AT ROTOR INLET	10.37	9.69	8.74	8.24	7.55
AIRFLOW AT ROTOR OUTLET	9.91	9.70	8.57	8.18	7.63
AIRFLOW AT STATOR OUTLET	10.25	9.49	8.73	7.91	7.18
ROTATIVE SPEED	8231.3	8268.0	8222.8	8267.5	8258.6
PERCENT OF DESIGN SPEED	89.8	90.2	89.7	90.2	90.1
COMPRESSOR PERFORMANCE					
STAGE TOTAL PRESSURE RATIO	1.157	1.204	1.231	1.241	1.246
STAGE TOTAL TEMPERATURE RATIO	1.055	1.062	1.068	1.072	1.077
STAGE ADIABATIC EFFICIENCY	0.777	0.876	0.901	0.881	0.844

(e) 80 Percent of design speed

READING NUMBER	3920
ROTOR TOTAL PRESSURE RATIO	1.209
STATOR TOTAL PRESSURE RATIO	0.985
ROTOR TOTAL TEMPERATURE RATIO	1.062
STATOR TOTAL TEMPERATURE RATIO	0.998
ROTOR ADIABATIC EFFICIENCY	0.906
ROTOR MOMENTUM-RISE EFFICIENCY	0.957
ROTOR HEAD-RISE COEFFICIENT	0.450
FLOW COEFFICIENT	0.405
AIRFLOW PER UNIT FRONTAL AREA	32.29
AIRFLOW PER UNIT ANNULUS AREA	89.68
AIRFLOW AT ORIFICE	6.54
AIRFLOW AT ROTOR INLET	6.75
AIRFLOW AT ROTOR OUTLET	6.99
AIRFLOW AT STATOR OUTLET	6.44
ROTATIVE SPEED	7339.0
PERCENT OF DESIGN SPEED	80.0
COMPRESSOR PERFORMANCE	
STAGE TOTAL PRESSURE RATIO	1.191
STAGE TOTAL TEMPERATURE RATIO	1.060
STAGE ADIABATIC EFFICIENCY	0.855

(f) 70 Percent of design speed

READING NUMBER	3926	3925	3924	3923	3922
ROTOR TOTAL PRESSURE RATIO	1.102	1.120	1.135	1.145	1.158
STATOR TOTAL PRESSURE RATIO	0.987	0.992	0.994	0.993	0.988
ROTOR TOTAL TEMPERATURE RATIO	1.031	1.036	1.040	1.043	1.047
STATOR TOTAL TEMPERATURE RATIO	1.001	1.000	1.000	1.000	0.999
ROTOR ADIABATIC EFFICIENCY	0.893	0.919	0.924	0.929	0.906
ROTOR MOMENTUM-RISE EFFICIENCY	0.905	0.944	0.957	0.965	0.949
ROTOR HEAD-RISE COEFFICIENT	0.287	0.337	0.378	0.409	0.443
FLOW COEFFICIENT	0.585	0.539	0.485	0.438	0.393
AIRFLOW PER UNIT FRONTAL AREA	40.33	37.37	33.86	30.72	27.69
AIRFLOW PER UNIT ANNULUS AREA	112.03	103.80	94.05	85.32	76.91
AIRFLOW AT ORIFICE	8.17	7.57	6.86	6.23	5.61
AIRFLOW AT ROTOR INLET	8.40	7.79	7.07	6.41	5.78
AIRFLOW AT ROTOR OUTLET	8.19	7.66	6.98	6.39	5.94
AIRFLOW AT STATOR OUTLET	8.27	7.58	6.89	6.21	5.54
ROTATIVE SPEED	6420.3	6428.9	6433.2	6421.2	6431.3
PERCENT OF DESIGN SPEED	70.0	70.1	70.2	70.0	70.1
COMPRESSOR PERFORMANCE					
STAGE TOTAL PRESSURE RATIO	1.088	1.111	1.128	1.138	1.144
STAGE TOTAL TEMPERATURE RATIO	1.032	1.036	1.040	1.043	1.046
STAGE ADIABATIC EFFICIENCY	0.757	0.853	0.880	0.879	0.844

TABLE 27. - Concluded.

(g) 60 Percent of design speed

READING NUMBER	3928
ROTOR TOTAL PRESSURE RATIO	1.112
STATOR TOTAL PRESSURE RATIO	0.992
ROTOR TOTAL TEMPERATURE RATIO	1.034
STATOR TOTAL TEMPERATURE RATIO	1.000
ROTOR ADIABATIC EFFICIENCY	0.918
ROTOR MOMENTUM-RISE EFFICIENCY	0.948
ROTOR HEAD-RISE COEFFICIENT	0.430
FLOW COEFFICIENT	0.390
AIRFLOW PER UNIT FRONTAL AREA	23.63
AIRFLOW PER UNIT ANNULUS AREA	65.63
AIRFLOW AT ORIFICE	4.79
AIRFLOW AT ROTOR INLET	4.93
AIRFLOW AT ROTOR OUTLET	5.04
AIRFLOW AT STATOR OUTLET	4.72
ROTATIVE SPEED	5499.0
PERCENT OF DESIGN SPEED	60.0

COMPRESSOR PERFORMANCE

STAGE TOTAL PRESSURE RATIO	1.103
STAGE TOTAL TEMPERATURE RATIO	1.033
STAGE ADIABATIC EFFICIENCY	0.846

(h) 50 Percent of design speed

READING NUMBER	3930
ROTOR TOTAL PRESSURE RATIO	1.077
STATOR TOTAL PRESSURE RATIO	0.994
ROTOR TOTAL TEMPERATURE RATIO	1.023
STATOR TOTAL TEMPERATURE RATIO	1.000
ROTOR ADIABATIC EFFICIENCY	0.919
ROTOR MOMENTUM-RISE EFFICIENCY	0.946
ROTOR HEAD-RISE COEFFICIENT	0.422
FLOW COEFFICIENT	0.390
AIRFLOW PER UNIT FRONTAL AREA	19.81
AIRFLOW PER UNIT ANNULUS AREA	55.03
AIRFLOW AT ORIFICE	4.02
AIRFLOW AT ROTOR INLET	4.15
AIRFLOW AT ROTOR OUTLET	4.23
AIRFLOW AT STATOR OUTLET	4.01
ROTATIVE SPEED	4601.7
PERCENT OF DESIGN SPEED	50.2

COMPRESSOR PERFORMANCE

STAGE TOTAL PRESSURE RATIO	1.071
STAGE TOTAL TEMPERATURE RATIO	1.024
STAGE ADIABATIC EFFICIENCY	0.838

TABLE 28. - OVERALL PERFORMANCE OF STAGE 27C-21

(a) 120 Percent of design speed

READING NUMBER	4362	4369	4366	4367	4368	4360
ROTOR TOTAL PRESSURE RATIO	1.334	1.376	1.437	1.477	1.496	1.514
STATOR TOTAL PRESSURE RATIO	0.980	0.984	0.981	0.975	0.973	0.970
ROTOR TOTAL TEMPERATURE RATIO	1.105	1.111	1.120	1.128	1.134	1.140
STATOR TOTAL TEMPERATURE RATIO	0.998	0.998	0.997	0.996	0.995	0.997
ROTOR ADIABATIC EFFICIENCY	0.818	0.863	0.911	0.924	0.914	0.897
ROTOR MOMENTUM-RISE EFFICIENCY	0.828	0.878	0.940	0.955	0.954	0.946
ROTOR HEAD-RISE COEFFICIENT	0.322	0.361	0.415	0.450	0.469	0.485
FLOW COEFFICIENT	0.564	0.562	0.542	0.508	0.480	0.444
AIRFLOW PER UNIT FRONTAL AREA	62.70	62.51	60.80	57.79	55.07	51.68
AIRFLOW PER UNIT ANNULUS AREA	174.16	173.63	168.89	160.54	152.98	143.56
AIRFLOW AT ORIFICE	12.71	12.67	12.32	11.71	11.16	10.47
AIRFLOW AT ROTOR INLET	12.81	12.77	12.42	11.81	11.28	10.56
AIRFLOW AT ROTOR OUTLET	12.53	12.53	12.23	11.82	11.35	10.62
AIRFLOW AT STATOR OUTLET	12.52	12.48	12.02	11.45	11.17	10.28
ROTATIVE SPEED	10983.2	10973.3	10975.3	10994.4	10985.7	10999.5
PERCENT OF DESIGN SPEED	119.8	119.7	119.7	119.9	119.8	120.0

COMPRESSOR PERFORMANCE

STAGE TOTAL PRESSURE RATIO	1.308	1.354	1.410	1.441	1.456	1.469
STAGE TOTAL TEMPERATURE RATIO	1.103	1.109	1.117	1.123	1.128	1.137
STAGE ADIABATIC EFFICIENCY	0.772	0.831	0.884	0.894	0.883	0.848

(b) 110 Percent of design speed

READING NUMBER	4356	4357	4358	4355
ROTOR TOTAL PRESSURE RATIO	1.257	1.356	1.392	1.414
STATOR TOTAL PRESSURE RATIO	0.974	0.984	0.981	0.973
ROTOR TOTAL TEMPERATURE RATIO	1.082	1.098	1.108	1.116
STATOR TOTAL TEMPERATURE RATIO	0.999	0.998	0.997	0.997
ROTOR ADIABATIC EFFICIENCY	0.821	0.924	0.917	0.897
ROTOR MOMENTUM-RISE EFFICIENCY	0.829	0.950	0.958	0.937
ROTOR HEAD-RISE COEFFICIENT	0.294	0.399	0.439	0.467
FLOW COEFFICIENT	0.581	0.535	0.481	0.433
AIRFLOW PER UNIT FRONTAL AREA	60.14	56.39	51.62	46.93
AIRFLOW PER UNIT ANNULUS AREA	167.06	156.65	143.40	130.37
AIRFLOW AT ORIFICE	12.19	11.43	10.46	9.51
AIRFLOW AT ROTOR INLET	12.29	11.52	10.55	9.60
AIRFLOW AT ROTOR OUTLET	12.12	11.39	10.36	9.54
AIRFLOW AT STATOR OUTLET	12.18	11.20	10.14	9.24
ROTATIVE SPEED	10097.3	10111.3	10112.3	10092.0
PERCENT OF DESIGN SPEED	110.1	110.3	110.3	110.1

COMPRESSOR PERFORMANCE

STAGE TOTAL PRESSURE RATIO	1.225	1.334	1.365	1.376
STAGE TOTAL TEMPERATURE RATIO	1.081	1.096	1.104	1.113
STAGE ADIABATIC EFFICIENCY	0.737	0.896	0.892	0.848

(c) 100 Percent of design speed

READING NUMBER	4349	4350	4351	4352	4353	4348
ROTOR TOTAL PRESSURE RATIO	1.197	1.237	1.265	1.289	1.308	1.327
STATOR TOTAL PRESSURE RATIO	0.967	0.981	0.987	0.987	0.987	0.979
ROTOR TOTAL TEMPERATURE RATIO	1.063	1.070	1.075	1.082	1.088	1.095
STATOR TOTAL TEMPERATURE RATIO	1.000	0.999	0.999	0.998	0.998	0.998
ROTOR ADIABATIC EFFICIENCY	0.839	0.902	0.920	0.921	0.909	0.888
ROTOR MOMENTUM-RISE EFFICIENCY	0.831	0.905	0.937	0.953	0.955	0.930
ROTOR HEAD-RISE COEFFICIENT	0.271	0.328	0.362	0.395	0.421	0.448
FLOW COEFFICIENT	0.597	0.580	0.550	0.508	0.466	0.418
AIRFLOW PER UNIT FRONTAL AREA	57.04	55.45	53.26	49.68	46.13	41.90
AIRFLOW PER UNIT ANNULUS AREA	158.46	154.04	147.94	137.99	128.13	116.38
AIRFLOW AT ORIFICE	11.56	11.24	10.79	10.07	9.35	8.49
AIRFLOW AT ROTOR INLET	11.64	11.33	10.88	10.16	9.44	8.55
AIRFLOW AT ROTOR OUTLET	11.41	11.13	10.73	10.00	9.26	8.50
AIRFLOW AT STATOR OUTLET	11.58	11.13	10.64	9.86	9.13	8.19
ROTATIVE SPEED	9186.5	9147.9	9181.9	9170.5	9183.2	9176.5
PERCENT OF DESIGN SPEED	100.2	99.8	100.1	100.0	100.1	100.1

COMPRESSOR PERFORMANCE

STAGE TOTAL PRESSURE RATIO	1.158	1.214	1.249	1.272	1.291	1.299
STAGE TOTAL TEMPERATURE RATIO	1.063	1.069	1.074	1.080	1.086	1.092
STAGE ADIABATIC EFFICIENCY	0.682	0.827	0.879	0.894	0.882	0.840

TABLE 2s. - Continued.

(d) 90 Percent of design speed

READING NUMBER	4374	4375	4376	4377	4378	4373
ROTOR TOTAL PRESSURE RATIO	1.150	1.177	1.203	1.222	1.240	1.255
STATOR TOTAL PRESSURE RATIO	0.965	0.979	0.988	0.990	0.990	0.985
ROTOR TOTAL TEMPERATURE RATIO	1.048	1.053	1.058	1.064	1.070	1.076
STATOR TOTAL TEMPERATURE RATIO	1.000	1.000	1.000	0.999	0.999	0.999
ROTOR ADIABATIC EFFICIENCY	0.850	0.904	0.927	0.918	0.910	0.888
ROTOR MOMENTUM-RISE EFFICIENCY	0.846	0.902	0.936	0.946	0.946	0.934
ROTOR HEAD-RISE COEFFICIENT	0.256	0.303	0.347	0.378	0.407	0.434
FLOW COEFFICIENT	0.610	0.590	0.551	0.507	0.463	0.417
AIRFLOW PER UNIT FRONTAL AREA	53.12	51.37	48.39	45.03	41.54	37.69
AIRFLOW PER UNIT ANNULUS AREA	147.57	142.70	134.42	125.09	115.39	104.68
AIRFLOW AT ORIFICE	10.77	10.41	9.81	9.13	8.42	7.64
AIRFLOW AT ROTOR INLET	10.87	10.52	9.92	9.24	8.52	7.73
AIRFLOW AT ROTOR OUTLET	10.70	10.37	9.80	9.10	8.36	7.63
AIRFLOW AT STATOR OUTLET	10.88	10.41	9.75	9.07	8.31	7.48
ROTATIVE SPEED	8260.7	8227.4	8228.7	8243.8	8260.2	8252.0
PERCENT OF DESIGN SPEED	90.1	89.7	89.7	89.9	90.1	90.0

COMPRESSOR PERFORMANCE

STAGE TOTAL PRESSURE RATIO	1.110	1.152	1.188	1.210	1.227	1.237
STAGE TOTAL TEMPERATURE RATIO	1.048	1.053	1.058	1.063	1.068	1.074
STAGE ADIABATIC EFFICIENCY	0.625	0.781	0.867	0.886	0.880	0.846

(e) 80 Percent of design speed

READING NUMBER	4380
ROTOR TOTAL PRESSURE RATIO	1.200
STATOR TOTAL PRESSURE RATIO	0.987
ROTOR TOTAL TEMPERATURE RATIO	1.060
STATOR TOTAL TEMPERATURE RATIO	0.999
ROTOR ADIABATIC EFFICIENCY	0.892
ROTOR MOMENTUM-RISE EFFICIENCY	0.930
ROTOR HEAD-RISE COEFFICIENT	0.429
FLOW COEFFICIENT	0.409
AIRFLOW PER UNIT FRONTAL AREA	33.18
AIRFLOW PER UNIT ANNULUS AREA	92.17
AIRFLOW AT ORIFICE	6.73
AIRFLOW AT ROTOR INLET	6.82
AIRFLOW AT ROTOR OUTLET	6.74
AIRFLOW AT STATOR OUTLET	6.63
ROTATIVE SPEED	7351.9
PERCENT OF DESIGN SPEED	80.2

COMPRESSOR PERFORMANCE

STAGE TOTAL PRESSURE RATIO	1.184
STAGE TOTAL TEMPERATURE RATIO	1.059
STAGE ADIABATIC EFFICIENCY	0.844

(f) 70 Percent of design speed

READING NUMBER	4383	4384	4385	4386	4387	4382
ROTOR TOTAL PRESSURE RATIO	1.086	1.102	1.115	1.125	1.137	1.147
STATOR TOTAL PRESSURE RATIO	0.975	0.985	0.992	0.995	0.995	0.991
ROTOR TOTAL TEMPERATURE RATIO	1.027	1.031	1.034	1.037	1.041	1.045
STATOR TOTAL TEMPERATURE RATIO	1.001	1.001	1.001	1.001	1.000	1.000
ROTOR ADIABATIC EFFICIENCY	0.874	0.916	0.924	0.925	0.915	0.897
ROTOR MOMENTUM-RISE EFFICIENCY	0.879	0.930	0.935	0.937	0.945	0.931
ROTOR HEAD-RISE COEFFICIENT	0.244	0.288	0.324	0.352	0.383	0.417
FLOW COEFFICIENT	0.619	0.583	0.539	0.498	0.453	0.404
AIRFLOW PER UNIT FRONTAL AREA	42.98	40.78	37.96	35.15	32.23	28.73
AIRFLOW PER UNIT ANNULUS AREA	119.39	113.28	105.46	97.64	89.52	79.80
AIRFLOW AT ORIFICE	8.71	8.27	7.69	7.12	6.53	5.82
AIRFLOW AT ROTOR INLET	8.82	8.38	7.80	7.23	6.63	5.92
AIRFLOW AT ROTOR OUTLET	8.72	8.28	7.70	7.08	6.48	5.85
AIRFLOW AT STATOR OUTLET	8.82	8.26	7.65	7.10	6.47	5.78
ROTATIVE SPEED	6414.9	6429.1	6430.7	6422.8	6439.8	6408.8
PERCENT OF DESIGN SPEED	70.0	70.1	70.1	70.0	70.2	69.9

COMPRESSOR PERFORMANCE

STAGE TOTAL PRESSURE RATIO	1.058	1.086	1.106	1.120	1.131	1.137
STAGE TOTAL TEMPERATURE RATIO	1.028	1.032	1.035	1.038	1.041	1.045
STAGE ADIABATIC EFFICIENCY	0.577	0.750	0.840	0.869	0.869	0.842

TABLE 28. - Concluded.

(g) 60 Percent of design speed

READING NUMBER	4391
ROTOR TOTAL PRESSURE RATIO	1.105
STATOR TOTAL PRESSURE RATIO	0.994
ROTOR TOTAL TEMPERATURE RATIO	1.032
STATOR TOTAL TEMPERATURE RATIO	1.001
ROTOR ADIABATIC EFFICIENCY	0.902
ROTOR MOMENTUM-RISE EFFICIENCY	0.934
ROTOR HEAD-RISE COEFFICIENT	0.406
FLOW COEFFICIENT	0.402
AIRFLOW PER UNIT FRONTAL AREA	24.63
AIRFLOW PER UNIT ANNULUS AREA	68.43
AIRFLOW AT ORIFICE	4.99
AIRFLOW AT ROTOR INLET	5.08
AIRFLOW AT ROTOR OUTLET	5.06
AIRFLOW AT STATOR OUTLET	4.96
ROTATIVE SPEED	5495.1
PERCENT OF DESIGN SPEED	59.9

COMPRESSOR PERFORMANCE

STAGE TOTAL PRESSURE RATIO	1.099
STAGE TOTAL TEMPERATURE RATIO	1.033
STAGE ADIABATIC EFFICIENCY	0.832

(h) 50 Percent of design speed

READING NUMBER	4395
ROTOR TOTAL PRESSURE RATIO	1.074
STATOR TOTAL PRESSURE RATIO	0.995
ROTOR TOTAL TEMPERATURE RATIO	1.023
STATOR TOTAL TEMPERATURE RATIO	1.000
ROTOR ADIABATIC EFFICIENCY	0.901
ROTOR MOMENTUM-RISE EFFICIENCY	0.920
ROTOR HEAD-RISE COEFFICIENT	0.408
FLOW COEFFICIENT	0.400
AIRFLOW PER UNIT FRONTAL AREA	20.72
AIRFLOW PER UNIT ANNULUS AREA	57.56
AIRFLOW AT ORIFICE	4.20
AIRFLOW AT ROTOR INLET	4.26
AIRFLOW AT ROTOR OUTLET	4.17
AIRFLOW AT STATOR OUTLET	4.12
ROTATIVE SPEED	4611.2
PERCENT OF DESIGN SPEED	50.3

COMPRESSOR PERFORMANCE

STAGE TOTAL PRESSURE RATIO	1.069
STAGE TOTAL TEMPERATURE RATIO	1.023
STAGE ADIABATIC EFFICIENCY	0.825

TABLE 29. - OVERALL PERFORMANCE OF STAGE 27D-21

(a) 120 Percent of design speed

READING NUMBER	4485	4484	4483	4481	4480	4479
ROTOR TOTAL PRESSURE RATIO	1.294	1.337	1.381	1.420	1.436	1.453
STATOR TOTAL PRESSURE RATIO	0.954	0.972	0.981	0.983	0.980	0.975
ROTOR TOTAL TEMPERATURE RATIO	1.091	1.099	1.109	1.117	1.122	1.128
STATOR TOTAL TEMPERATURE RATIO	0.999	0.999	0.999	0.998	0.998	0.997
ROTOR ADIABATIC EFFICIENCY	0.839	0.872	0.888	0.899	0.895	0.880
ROTOR MOMENTUM-RISE EFFICIENCY	0.837	0.872	0.902	0.935	0.932	0.916
ROTOR HEAD-RISE COEFFICIENT	0.281	0.321	0.362	0.397	0.413	0.431
FLOW COEFFICIENT	0.597	0.586	0.558	0.516	0.494	0.462
AIRFLOW PER UNIT FRONTAL AREA	65.15	64.17	61.87	58.15	55.99	52.80
AIRFLOW PER UNIT ANNULUS AREA	180.97	178.25	171.88	161.53	155.53	146.67
AIRFLOW AT ORIFICE	13.20	13.01	12.54	11.79	11.35	10.70
AIRFLOW AT ROTOR INLET	13.38	13.20	12.73	11.99	11.56	10.93
AIRFLOW AT ROTOR OUTLET	13.47	13.14	12.53	11.89	11.47	10.94
AIRFLOW AT STATOR OUTLET	13.33	12.97	12.37	11.51	11.04	10.39
ROTATIVE SPEED	11020.7	11011.4	11013.2	11016.8	10999.2	10977.4
PERCENT OF DESIGN SPEED	120.2	120.1	120.1	120.1	119.9	119.7

COMPRESSOR PERFORMANCE

STAGE TOTAL PRESSURE RATIO	1.234	1.300	1.356	1.395	1.408	1.416
STAGE TOTAL TEMPERATURE RATIO	1.090	1.098	1.107	1.115	1.119	1.125
STAGE ADIABATIC EFFICIENCY	0.691	0.792	0.847	0.867	0.859	0.836

(b) 110 Percent of design speed

READING NUMBER	4475	4476	4477	4473
ROTOR TOTAL PRESSURE RATIO	1.252	1.311	1.342	1.365
STATOR TOTAL PRESSURE RATIO	0.948	0.980	0.982	0.980
ROTOR TOTAL TEMPERATURE RATIO	1.073	1.086	1.095	1.105
STATOR TOTAL TEMPERATURE RATIO	1.000	0.999	0.998	0.997
ROTOR ADIABATIC EFFICIENCY	0.905	0.933	0.923	0.890
ROTOR MOMENTUM-RISE EFFICIENCY	0.895	0.929	0.947	0.937
ROTOR HEAD-RISE COEFFICIENT	0.286	0.352	0.387	0.416
FLOW COEFFICIENT	0.627	0.562	0.517	0.460
AIRFLOW PER UNIT FRONTAL AREA	63.40	58.08	54.16	48.92
AIRFLOW PER UNIT ANNULUS AREA	176.10	161.32	150.45	135.90
AIRFLOW AT ORIFICE	12.85	11.77	10.98	9.92
AIRFLOW AT ROTOR INLET	13.01	11.94	11.16	10.09
AIRFLOW AT ROTOR OUTLET	12.91	11.87	11.23	10.14
AIRFLOW AT STATOR OUTLET	13.02	11.72	10.84	9.62
ROTATIVE SPEED	10087.8	10074.4	10076.5	10049.8
PERCENT OF DESIGN SPEED	110.0	109.9	109.9	109.6

COMPRESSOR PERFORMANCE

STAGE TOTAL PRESSURE RATIO	1.186	1.284	1.317	1.338
STAGE TOTAL TEMPERATURE RATIO	1.073	1.085	1.092	1.101
STAGE ADIABATIC EFFICIENCY	0.684	0.873	0.887	0.858

(c) 100 Percent of design speed

READING NUMBER	4497	4498	4467	4468	4471	4500
ROTOR TOTAL PRESSURE RATIO	1.203	1.225	1.242	1.258	1.280	1.291
STATOR TOTAL PRESSURE RATIO	0.954	0.974	0.983	0.990	0.986	0.984
ROTOR TOTAL TEMPERATURE RATIO	1.059	1.064	1.068	1.073	1.081	1.086
STATOR TOTAL TEMPERATURE RATIO	1.000	1.000	1.000	1.000	0.998	0.998
ROTOR ADIABATIC EFFICIENCY	0.928	0.936	0.938	0.928	0.904	0.879
ROTOR MOMENTUM-RISE EFFICIENCY	0.939	0.942	0.939	0.936	0.925	0.919
ROTOR HEAD-RISE COEFFICIENT	0.280	0.307	0.331	0.353	0.386	0.397
FLOW COEFFICIENT	0.629	0.593	0.551	0.513	0.471	0.447
AIRFLOW PER UNIT FRONTAL AREA	58.89	56.28	52.97	49.85	46.03	44.04
AIRFLOW PER UNIT ANNULUS AREA	163.57	156.34	147.15	138.47	127.85	122.34
AIRFLOW AT ORIFICE	11.94	11.41	10.74	10.10	9.33	8.93
AIRFLOW AT ROTOR INLET	12.11	11.60	10.91	10.27	9.49	9.11
AIRFLOW AT ROTOR OUTLET	11.99	11.41	10.79	10.05	9.43	9.15
AIRFLOW AT STATOR OUTLET	12.09	11.44	10.68	9.97	9.15	8.74
ROTATIVE SPEED	9162.8	9199.3	9186.6	9186.9	9150.6	9211.6
PERCENT OF DESIGN SPEED	99.9	100.3	100.2	100.2	99.8	100.5

COMPRESSOR PERFORMANCE

STAGE TOTAL PRESSURE RATIO	1.148	1.193	1.221	1.246	1.262	1.270
STAGE TOTAL TEMPERATURE RATIO	1.059	1.064	1.068	1.073	1.079	1.084
STAGE ADIABATIC EFFICIENCY	0.688	0.808	0.865	0.884	0.867	0.847

TABLE 29. - Continued.

(d) 90 Percent of design speed

READING NUMBER	4495	4496
ROTOR TOTAL PRESSURE RATIO	1.158	1.171
STATOR TOTAL PRESSURE RATIO	0.962	0.975
ROTOR TOTAL TEMPERATURE RATIO	1.046	1.050
STATOR TOTAL TEMPERATURE RATIO	1.000	1.000
ROTOR ADIABATIC EFFICIENCY	0.931	0.929
ROTOR MOMENTUM-RISE EFFICIENCY	0.937	0.940
ROTOR HEAD-RISE COEFFICIENT	0.271	0.291
FLOW COEFFICIENT	0.622	0.588
AIRFLOW PER UNIT FRONTAL AREA	53.38	50.98
AIRFLOW PER UNIT ANNULUS AREA	148.29	141.61
AIRFLOW AT ORIFICE	10.82	10.33
AIRFLOW AT ROTOR INLET	11.01	10.52
AIRFLOW AT ROTOR OUTLET	10.82	10.35
AIRFLOW AT STATOR OUTLET	10.94	10.36
ROTATIVE SPEED	8236.5	8252.3
PERCENT OF DESIGN SPEED	89.8	90.0
COMPRESSOR PERFORMANCE		
STAGE TOTAL PRESSURE RATIO	1.114	1.142
STAGE TOTAL TEMPERATURE RATIO	1.046	1.050
STAGE ADIABATIC EFFICIENCY	0.676	0.778

(e) 80 Percent of design speed

READING NUMBER	4502
ROTOR TOTAL PRESSURE RATIO	1.174
STATOR TOTAL PRESSURE RATIO	0.992
ROTOR TOTAL TEMPERATURE RATIO	1.053
STATOR TOTAL TEMPERATURE RATIO	1.000
ROTOR ADIABATIC EFFICIENCY	0.885
ROTOR MOMENTUM-RISE EFFICIENCY	0.921
ROTOR HEAD-RISE COEFFICIENT	0.373
FLOW COEFFICIENT	0.439
AIRFLOW PER UNIT FRONTAL AREA	35.17
AIRFLOW PER UNIT ANNULUS AREA	97.70
AIRFLOW AT ORIFICE	7.13
AIRFLOW AT ROTOR INLET	7.30
AIRFLOW AT ROTOR OUTLET	7.21
AIRFLOW AT STATOR OUTLET	7.08
ROTATIVE SPEED	7357.6
PERCENT OF DESIGN SPEED	80.2
COMPRESSOR PERFORMANCE	
STAGE TOTAL PRESSURE RATIO	1.165
STAGE TOTAL TEMPERATURE RATIO	1.053
STAGE ADIABATIC EFFICIENCY	0.845

(f) 70 Percent of design speed

READING NUMBER	4510	4509	4508	4507	4506	4505
ROTOR TOTAL PRESSURE RATIO	1.091	1.096	1.102	1.111	1.124	1.132
STATOR TOTAL PRESSURE RATIO	0.976	0.983	0.988	0.993	0.995	0.993
ROTOR TOTAL TEMPERATURE RATIO	1.027	1.029	1.031	1.033	1.038	1.041
STATOR TOTAL TEMPERATURE RATIO	1.001	1.001	1.001	1.001	1.000	1.000
ROTOR ADIABATIC EFFICIENCY	0.922	0.924	0.917	0.926	0.907	0.878
ROTOR MOMENTUM-RISE EFFICIENCY	0.945	0.942	0.947	0.947	0.931	0.904
ROTOR HEAD-RISE COEFFICIENT	0.253	0.267	0.285	0.310	0.347	0.371
FLOW COEFFICIENT	0.608	0.580	0.553	0.519	0.460	0.414
AIRFLOW PER UNIT FRONTAL AREA	42.31	40.53	38.69	36.36	32.47	29.28
AIRFLOW PER UNIT ANNULUS AREA	117.54	112.59	107.47	101.01	90.19	81.34
AIRFLOW AT ORIFICE	8.58	8.22	7.84	7.37	6.58	5.94
AIRFLOW AT ROTOR INLET	8.74	8.38	8.02	7.54	6.73	6.08
AIRFLOW AT ROTOR OUTLET	8.57	8.20	7.87	7.44	6.62	5.97
AIRFLOW AT STATOR OUTLET	8.69	8.28	7.90	7.42	6.56	5.90
ROTATIVE SPEED	6472.1	6466.0	6464.8	6443.6	6447.7	6433.7
PERCENT OF DESIGN SPEED	70.6	70.5	70.5	70.3	70.3	70.2
COMPRESSOR PERFORMANCE						
STAGE TOTAL PRESSURE RATIO	1.064	1.077	1.090	1.103	1.119	1.124
STAGE TOTAL TEMPERATURE RATIO	1.028	1.030	1.031	1.034	1.038	1.041
STAGE ADIABATIC EFFICIENCY	0.639	0.728	0.789	0.839	0.859	0.823

TABLE 29. - Concluded.

(g) 60 Percent of design speed

READING NUMBER	4514
ROTOR TOTAL PRESSURE RATIO	1.095
STATOR TOTAL PRESSURE RATIO	0.995
ROTOR TOTAL TEMPERATURE RATIO	1.030
STATOR TOTAL TEMPERATURE RATIO	1.001
ROTOR ADIABATIC EFFICIENCY	0.880
ROTOR MOMENTUM-RISE EFFICIENCY	0.910
ROTOR HEAD-RISE COEFFICIENT	0.360
FLOW COEFFICIENT	0.416
AIRFLOW PER UNIT FRONTAL AREA	25.50
AIRFLOW PER UNIT ANNULUS AREA	70.82
AIRFLOW AT ORIFICE	5.17
AIRFLOW AT ROTOR INLET	5.29
AIRFLOW AT ROTOR OUTLET	5.19
AIRFLOW AT STATOR OUTLET	5.10
ROTATIVE SPEED	5540.9
PERCENT OF DESIGN SPEED	60.4

COMPRESSOR PERFORMANCE

STAGE TOTAL PRESSURE RATIO	1.090
STAGE TOTAL TEMPERATURE RATIO	1.030
STAGE ADIABATIC EFFICIENCY	0.816

(h) 50 Percent of design speed

READING NUMBER	4516
ROTOR TOTAL PRESSURE RATIO	1.064
STATOR TOTAL PRESSURE RATIO	0.997
ROTOR TOTAL TEMPERATURE RATIO	1.020
STATOR TOTAL TEMPERATURE RATIO	1.001
ROTOR ADIABATIC EFFICIENCY	0.885
ROTOR MOMENTUM-RISE EFFICIENCY	0.910
ROTOR HEAD-RISE COEFFICIENT	0.349
FLOW COEFFICIENT	0.418
AIRFLOW PER UNIT FRONTAL AREA	21.44
AIRFLOW PER UNIT ANNULUS AREA	59.56
AIRFLOW AT ORIFICE	4.35
AIRFLOW AT ROTOR INLET	4.46
AIRFLOW AT ROTOR OUTLET	4.36
AIRFLOW AT STATOR OUTLET	4.31
ROTATIVE SPEED	4624.2
PERCENT OF DESIGN SPEED	50.4

COMPRESSOR PERFORMANCE

STAGE TOTAL PRESSURE RATIO	1.061
STAGE TOTAL TEMPERATURE RATIO	1.021
STAGE ADIABATIC EFFICIENCY	0.807

TABLE 30. - OVERALL PERFORMANCE OF STAGE 27D-21D

(a) 120 Percent of design speed

READING NUMBER	0014	0015	0016	0017	0018	0011
ROTOR TOTAL PRESSURE RATIO	1.227	1.294	1.357	1.401	1.433	1.457
STATOR TOTAL PRESSURE RATIO	0.974	0.985	0.988	0.980	0.976	0.973
ROTOR TOTAL TEMPERATURE RATIO	1.080	1.092	1.104	1.112	1.121	1.130
STATOR TOTAL TEMPERATURE RATIO	0.998	0.999	1.000	0.998	0.998	0.998
ROTOR ADIABATIC EFFICIENCY	0.750	0.834	0.879	0.902	0.895	0.877
ROTOR MOMENTUM-RISE EFFICIENCY	0.788	0.868	0.912	0.937	0.930	0.912
ROTOR HEAD-RISE COEFFICIENT	0.220	0.283	0.340	0.381	0.412	0.434
FLOW COEFFICIENT	0.607	0.599	0.579	0.536	0.496	0.459
AIRFLOW PER UNIT FRONTAL AREA	66.28	65.47	63.81	60.10	56.26	52.72
AIRFLOW PER UNIT ANNULUS AREA	184.10	181.85	177.25	166.95	156.27	146.44
AIRFLOW AT ORIFICE	13.43	13.27	12.93	12.18	11.40	10.68
AIRFLOW AT ROTOR INLET	13.55	13.40	13.08	12.34	11.59	10.88
AIRFLOW AT ROTOR OUTLET	13.83	13.62	13.13	12.45	11.70	11.03
AIRFLOW AT STATOR OUTLET	13.48	13.16	12.72	11.89	10.64	9.61
ROTATIVE SPEED	11011.6	11000.8	11004.3	10994.7	10976.1	11000.8
PERCENT OF DESIGN SPEED	120.1	120.0	120.0	119.9	119.7	120.0
COMPRESSOR PERFORMANCE						
STAGE TOTAL PRESSURE RATIO	1.195	1.275	1.341	1.373	1.399	1.418
STAGE TOTAL TEMPERATURE RATIO	1.078	1.091	1.104	1.110	1.119	1.127
STAGE ADIABATIC EFFICIENCY	0.667	0.790	0.845	0.859	0.850	0.824

(b) 110 Percent of design speed

READING NUMBER	0028	0029	0027
ROTOR TOTAL PRESSURE RATIO	1.240	1.312	1.361
STATOR TOTAL PRESSURE RATIO	0.983	0.989	0.980
ROTOR TOTAL TEMPERATURE RATIO	1.071	1.087	1.103
STATOR TOTAL TEMPERATURE RATIO	1.000	0.999	0.998
ROTOR ADIABATIC EFFICIENCY	0.889	0.927	0.897
ROTOR MOMENTUM-RISE EFFICIENCY	0.910	0.962	0.929
ROTOR HEAD-RISE COEFFICIENT	0.277	0.358	0.412
FLOW COEFFICIENT	0.634	0.546	0.464
AIRFLOW PER UNIT FRONTAL AREA	63.79	56.68	49.32
AIRFLOW PER UNIT ANNULUS AREA	177.21	157.44	136.99
AIRFLOW AT ORIFICE	12.93	11.49	10.00
AIRFLOW AT ROTOR INLET	13.04	11.62	10.16
AIRFLOW AT ROTOR OUTLET	13.04	11.71	10.24
AIRFLOW AT STATOR OUTLET	12.81	11.41	9.25
ROTATIVE SPEED	10013.0	10011.0	10037.5
PERCENT OF DESIGN SPEED	109.2	109.2	109.5
COMPRESSOR PERFORMANCE			
STAGE TOTAL PRESSURE RATIO	1.219	1.298	1.333
STAGE TOTAL TEMPERATURE RATIO	1.072	1.086	1.101
STAGE ADIABATIC EFFICIENCY	0.814	0.898	0.850

(c) 100 Percent of design speed

READING NUMBER	0005	0006	0007	0008	0009	0004
ROTOR TOTAL PRESSURE RATIO	1.172	1.216	1.237	1.257	1.274	1.288
STATOR TOTAL PRESSURE RATIO	0.980	0.989	0.991	0.993	0.987	0.983
ROTOR TOTAL TEMPERATURE RATIO	1.053	1.062	1.067	1.073	1.079	1.084
STATOR TOTAL TEMPERATURE RATIO	1.000	1.000	1.000	1.000	0.999	0.999
ROTOR ADIABATIC EFFICIENCY	0.881	0.933	0.935	0.930	0.910	0.887
ROTOR MOMENTUM-RISE EFFICIENCY	0.900	0.971	0.967	0.972	0.948	0.908
ROTOR HEAD-RISE COEFFICIENT	0.237	0.298	0.326	0.352	0.376	0.395
FLOW COEFFICIENT	0.655	0.619	0.570	0.525	0.485	0.450
AIRFLOW PER UNIT FRONTAL AREA	61.14	58.38	54.51	50.91	47.44	44.16
AIRFLOW PER UNIT ANNULUS AREA	169.83	162.18	151.41	141.41	131.78	122.68
AIRFLOW AT ORIFICE	12.39	11.83	11.05	10.32	9.62	8.95
AIRFLOW AT ROTOR INLET	12.52	11.97	11.20	10.47	9.77	9.13
AIRFLOW AT ROTOR OUTLET	12.45	11.98	11.22	10.50	9.82	9.13
AIRFLOW AT STATOR OUTLET	12.43	11.76	10.95	10.28	9.45	8.48
ROTATIVE SPEED	9172.3	9164.2	9164.1	9180.7	9180.8	9171.0
PERCENT OF DESIGN SPEED	100.0	99.9	99.9	100.1	100.1	100.0
COMPRESSOR PERFORMANCE						
STAGE TOTAL PRESSURE RATIO	1.148	1.203	1.226	1.248	1.258	1.265
STAGE TOTAL TEMPERATURE RATIO	1.053	1.062	1.067	1.073	1.078	1.083
STAGE ADIABATIC EFFICIENCY	0.761	0.873	0.899	0.899	0.869	0.839

TABLE 30. - Continued.

(d) 90 Percent of design speed

READING NUMBER	0049	0048	0047	0046	0045
ROTOR TOTAL PRESSURE RATIO	1.139	1.172	1.190	1.209	1.233
STATOR TOTAL PRESSURE RATIO	0.981	0.988	0.992	0.992	0.983
ROTOR TOTAL TEMPERATURE RATIO	1.041	1.049	1.054	1.060	1.069
STATOR TOTAL TEMPERATURE RATIO	1.001	1.000	1.000	1.000	0.998
ROTOR ADIABATIC EFFICIENCY	0.914	0.946	0.943	0.930	0.891
ROTOR MOMENTUM-RISE EFFICIENCY	0.929	0.976	0.974	0.961	0.920
ROTOR HEAD-RISE COEFFICIENT	0.236	0.292	0.323	0.356	0.397
FLOW COEFFICIENT	0.660	0.612	0.558	0.507	0.442
AIRFLOW PER UNIT FRONTAL AREA	56.70	53.10	48.91	44.94	39.62
AIRFLOW PER UNIT ANNULUS AREA	157.50	147.49	135.88	124.85	110.06
AIRFLOW AT ORIFICE	11.49	10.76	9.91	9.11	8.03
AIRFLOW AT ROTOR INLET	11.61	10.88	10.04	9.25	8.15
AIRFLOW AT ROTOR OUTLET	11.57	10.91	10.11	9.29	8.28
AIRFLOW AT STATOR OUTLET	11.45	10.64	9.81	8.98	7.65
ROTATIVE SPEED	8269.0	8253.1	8237.5	8242.0	8241.0
PERCENT OF DESIGN SPEED	90.2	90.0	89.8	89.9	89.9

COMPRESSOR PERFORMANCE

STAGE TOTAL PRESSURE RATIO	1.117	1.159	1.180	1.200	1.212
STAGE TOTAL TEMPERATURE RATIO	1.042	1.049	1.054	1.060	1.067
STAGE ADIABATIC EFFICIENCY	0.763	0.872	0.899	0.897	0.840

(e) 80 Percent of design speed

READING NUMBER	0020
ROTOR TOTAL PRESSURE RATIO	1.177
STATOR TOTAL PRESSURE RATIO	0.986
ROTOR TOTAL TEMPERATURE RATIO	1.054
STATOR TOTAL TEMPERATURE RATIO	0.999
ROTOR ADIABATIC EFFICIENCY	0.883
ROTOR MOMENTUM-RISE EFFICIENCY	0.907
ROTOR HEAD-RISE COEFFICIENT	0.382
FLOW COEFFICIENT	0.424
AIRFLOW PER UNIT FRONTAL AREA	34.04
AIRFLOW PER UNIT ANNULUS AREA	94.55
AIRFLOW AT ORIFICE	6.90
AIRFLOW AT ROTOR INLET	7.04
AIRFLOW AT ROTOR OUTLET	7.10
AIRFLOW AT STATOR OUTLET	6.51
ROTATIVE SPEED	7340.9
PERCENT OF DESIGN SPEED	80.1

COMPRESSOR PERFORMANCE

STAGE TOTAL PRESSURE RATIO	1.161
STAGE TOTAL TEMPERATURE RATIO	1.053
STAGE ADIABATIC EFFICIENCY	0.819

(f) 70 Percent of design speed

READING NUMBER	0039	0040	0041	0042	0043	0036
ROTOR TOTAL PRESSURE RATIO	1.078	1.092	1.104	1.116	1.126	1.136
STATOR TOTAL PRESSURE RATIO	0.987	0.991	0.994	0.995	0.994	0.989
ROTOR TOTAL TEMPERATURE RATIO	1.023	1.027	1.030	1.034	1.038	1.042
STATOR TOTAL TEMPERATURE RATIO	1.001	1.001	1.000	1.000	1.000	1.000
ROTOR ADIABATIC EFFICIENCY	0.935	0.953	0.950	0.943	0.916	0.890
ROTOR MOMENTUM-RISE EFFICIENCY	0.956	0.974	0.978	0.974	0.950	0.903
ROTOR HEAD-RISE COEFFICIENT	0.220	0.261	0.292	0.326	0.358	0.383
FLOW COEFFICIENT	0.658	0.615	0.565	0.515	0.467	0.413
AIRFLOW PER UNIT FRONTAL AREA	45.51	42.67	39.54	36.22	32.85	29.30
AIRFLOW PER UNIT ANNULUS AREA	126.41	118.53	109.83	100.62	91.25	81.40
AIRFLOW AT ORIFICE	9.22	8.65	8.01	7.34	6.66	5.94
AIRFLOW AT ROTOR INLET	9.35	8.77	8.13	7.46	6.78	6.05
AIRFLOW AT ROTOR OUTLET	9.29	8.77	8.11	7.50	6.81	6.10
AIRFLOW AT STATOR OUTLET	9.21	8.60	7.90	7.26	6.59	5.64
ROTATIVE SPEED	6435.0	6411.6	6428.0	6428.2	6399.8	6417.4
PERCENT OF DESIGN SPEED	70.2	69.9	70.1	70.1	69.8	70.0

COMPRESSOR PERFORMANCE

STAGE TOTAL PRESSURE RATIO	1.064	1.082	1.097	1.110	1.119	1.124
STAGE TOTAL TEMPERATURE RATIO	1.024	1.027	1.031	1.034	1.038	1.041
STAGE ADIABATIC EFFICIENCY	0.738	0.835	0.880	0.890	0.864	0.816

TABLE 30. - Concluded.

(g) 60 Percent of design speed

READING NUMBER	0022
ROTOR TOTAL PRESSURE RATIO	1.096
STATOR TOTAL PRESSURE RATIO	0.993
ROTOR TOTAL TEMPERATURE RATIO	1.029
STATOR TOTAL TEMPERATURE RATIO	1.000
ROTOR ADIABATIC EFFICIENCY	0.902
ROTOR MOMENTUM-RISE EFFICIENCY	0.903
ROTOR HEAD-RISE COEFFICIENT	0.368
FLOW COEFFICIENT	0.410
AIRFLOW PER UNIT FRONTAL AREA	24.96
AIRFLOW PER UNIT ANNULUS AREA	69.34
AIRFLOW AT ORIFICE	5.06
AIRFLOW AT ROTOR INLET	5.18
AIRFLOW AT ROTOR OUTLET	5.17
AIRFLOW AT STATOR OUTLET	4.77
ROTATIVE SPEED	5501.9
PERCENT OF DESIGN SPEED	60.0

COMPRESSOR PERFORMANCE

STAGE TOTAL PRESSURE RATIO	1.088
STAGE TOTAL TEMPERATURE RATIO	1.030
STAGE ADIABATIC EFFICIENCY	0.823

(h) 50 Percent of design speed

READING NUMBER	0025
ROTOR TOTAL PRESSURE RATIO	1.065
STATOR TOTAL PRESSURE RATIO	0.995
ROTOR TOTAL TEMPERATURE RATIO	1.021
STATOR TOTAL TEMPERATURE RATIO	1.000
ROTOR ADIABATIC EFFICIENCY	0.884
ROTOR MOMENTUM-RISE EFFICIENCY	0.900
ROTOR HEAD-RISE COEFFICIENT	0.361
FLOW COEFFICIENT	0.406
AIRFLOW PER UNIT FRONTAL AREA	20.68
AIRFLOW PER UNIT ANNULUS AREA	57.44
AIRFLOW AT ORIFICE	4.19
AIRFLOW AT ROTOR INLET	4.29
AIRFLOW AT ROTOR OUTLET	4.26
AIRFLOW AT STATOR OUTLET	3.90
ROTATIVE SPEED	4581.5
PERCENT OF DESIGN SPEED	50.0

COMPRESSOR PERFORMANCE

STAGE TOTAL PRESSURE RATIO	1.060
STAGE TOTAL TEMPERATURE RATIO	1.021
STAGE ADIABATIC EFFICIENCY	0.798

TABLE 31. - OVERALL PERFORMANCE OF STAGE 28B-22

(a) 120 Percent of design speed

READING NUMBER	3796	3795	3794	3793
ROTOR TOTAL PRESSURE RATIO	1.501	1.575	1.587	1.612
STATOR TOTAL PRESSURE RATIO	0.970	0.959	0.956	0.943
ROTOR TOTAL TEMPERATURE RATIO	1.144	1.151	1.153	1.160
STATOR TOTAL TEMPERATURE RATIO	0.996	0.995	0.998	0.997
ROTOR ADIABATIC EFFICIENCY	0.857	0.918	0.923	0.915
ROTOR MOMENTUM-RISE EFFICIENCY	0.889	0.956	0.955	0.941
ROTOR HEAD-RISE COEFFICIENT	0.473	0.537	0.551	0.574
FLOW COEFFICIENT	0.554	0.518	0.487	0.455
AIRFLOW PER UNIT FRONTAL AREA	61.16	58.12	55.15	52.06
AIRFLOW PER UNIT ANNULUS AREA	169.89	161.46	153.19	144.61
AIRFLOW AT ORIFICE	12.40	11.78	11.18	10.55
AIRFLOW AT ROTOR INLET	12.70	12.04	11.43	10.81
AIRFLOW AT ROTOR OUTLET	12.52	12.27	11.76	11.24
AIRFLOW AT STATOR OUTLET	12.15	11.43	11.01	10.61
ROTATIVE SPEED	11043.2	11021.5	10994.0	10997.7
PERCENT OF DESIGN SPEED	120.4	120.2	119.9	119.9

COMPRESSOR PERFORMANCE

STAGE TOTAL PRESSURE RATIO	1.457	1.510	1.517	1.521
STAGE TOTAL TEMPERATURE RATIO	1.140	1.146	1.150	1.156
STAGE ADIABATIC EFFICIENCY	0.813	0.859	0.841	0.815

(b) 110 Percent of design speed

READING NUMBER	3761	3790	3762	3766
ROTOR TOTAL PRESSURE RATIO	1.386	1.452	1.460	1.478
STATOR TOTAL PRESSURE RATIO	0.972	0.970	0.969	0.963
ROTOR TOTAL TEMPERATURE RATIO	1.114	1.122	1.124	1.130
STATOR TOTAL TEMPERATURE RATIO	0.997	0.997	0.997	0.999
ROTOR ADIABATIC EFFICIENCY	0.856	0.921	0.920	0.907
ROTOR MOMENTUM-RISE EFFICIENCY	0.870	0.959	0.961	0.937
ROTOR HEAD-RISE COEFFICIENT	0.441	0.504	0.518	0.539
FLOW COEFFICIENT	0.572	0.536	0.506	0.448
AIRFLOW PER UNIT FRONTAL AREA	58.24	55.71	52.90	47.58
AIRFLOW PER UNIT ANNULUS AREA	161.78	154.74	146.96	132.18
AIRFLOW AT ORIFICE	11.80	11.29	10.72	9.64
AIRFLOW AT ROTOR INLET	12.11	11.54	10.97	9.89
AIRFLOW AT ROTOR OUTLET	11.92	11.56	11.09	10.19
AIRFLOW AT STATOR OUTLET	11.55	10.93	10.36	9.64
ROTATIVE SPEED	10056.0	10113.5	10069.3	10071.2
PERCENT OF DESIGN SPEED	109.7	110.3	109.8	109.8

COMPRESSOR PERFORMANCE

STAGE TOTAL PRESSURE RATIO	1.347	1.408	1.415	1.423
STAGE TOTAL TEMPERATURE RATIO	1.111	1.118	1.121	1.129
STAGE ADIABATIC EFFICIENCY	0.801	0.870	0.864	0.821

(c) 100 Percent of design speed

READING NUMBER	3760	3755	3756	3757	3758
ROTOR TOTAL PRESSURE RATIO	1.280	1.353	1.364	1.372	1.378
STATOR TOTAL PRESSURE RATIO	0.971	0.976	0.978	0.978	0.974
ROTOR TOTAL TEMPERATURE RATIO	1.089	1.098	1.100	1.103	1.106
STATOR TOTAL TEMPERATURE RATIO	0.999	0.998	0.999	1.000	1.000
ROTOR ADIABATIC EFFICIENCY	0.824	0.925	0.929	0.917	0.901
ROTOR MOMENTUM-RISE EFFICIENCY	0.833	0.951	0.967	0.951	0.938
ROTOR HEAD-RISE COEFFICIENT	0.387	0.483	0.495	0.508	0.515
FLOW COEFFICIENT	0.591	0.548	0.509	0.469	0.438
AIRFLOW PER UNIT FRONTAL AREA	55.62	52.15	49.08	45.61	42.85
AIRFLOW PER UNIT ANNULUS AREA	154.51	144.86	136.33	126.68	119.04
AIRFLOW AT ORIFICE	11.27	10.57	9.95	9.24	8.69
AIRFLOW AT ROTOR INLET	11.56	10.84	10.20	9.49	8.92
AIRFLOW AT ROTOR OUTLET	11.33	10.89	10.22	9.64	9.16
AIRFLOW AT STATOR OUTLET	11.29	10.51	9.92	9.33	8.73
ROTATIVE SPEED	9180.9	9163.4	9180.4	9176.3	9181.2
PERCENT OF DESIGN SPEED	100.1	99.9	100.1	100.1	100.1

COMPRESSOR PERFORMANCE

STAGE TOTAL PRESSURE RATIO	1.243	1.321	1.334	1.343	1.342
STAGE TOTAL TEMPERATURE RATIO	1.087	1.095	1.098	1.103	1.107
STAGE ADIABATIC EFFICIENCY	0.732	0.873	0.873	0.855	0.822

TABLE 31. - Continued.

(d) 90 Percent of design speed

READING NUMBER	3768	3789	3772	3773	3775
ROTOR TOTAL PRESSURE RATIO	1.191	1.267	1.286	1.302	1.308
STATOR TOTAL PRESSURE RATIO	0.960	0.981	0.982	0.976	0.971
ROTOR TOTAL TEMPERATURE RATIO	1.065	1.076	1.080	1.085	1.088
STATOR TOTAL TEMPERATURE RATIO	1.000	0.999	0.998	0.998	0.998
ROTOR ADIABATIC EFFICIENCY	0.781	0.916	0.927	0.923	0.903
ROTOR MOMENTUM-RISE EFFICIENCY	0.792	0.940	0.956	0.962	0.935
ROTOR HEAD-RISE COEFFICIENT	0.328	0.451	0.480	0.508	0.520
FLOW COEFFICIENT	0.617	0.571	0.516	0.468	0.428
AIRFLOW PER UNIT FRONTAL AREA	52.69	49.34	45.35	41.50	38.13
AIRFLOW PER UNIT ANNULUS AREA	146.37	137.06	125.98	115.29	105.91
AIRFLOW AT ORIFICE	10.68	10.00	9.19	8.41	7.73
AIRFLOW AT ROTOR INLET	10.96	10.28	9.43	8.63	7.94
AIRFLOW AT ROTOR OUTLET	10.72	10.14	9.43	8.82	8.31
AIRFLOW AT STATOR OUTLET	10.71	10.00	9.18	8.37	7.78
ROTATIVE SPEED	8248.6	8262.7	8282.6	8272.0	8255.9
PERCENT OF DESIGN SPEED	.90.0	90.1	90.3	90.2	90.0
COMPRESSOR PERFORMANCE					
STAGE TOTAL PRESSURE RATIO	1.143	1.243	1.262	1.270	1.270
STAGE TOTAL TEMPERATURE RATIO	1.066	1.075	1.079	1.082	1.086
STAGE ADIABATIC EFFICIENCY	0.594	0.854	0.875	0.860	0.823

(e) 80 Percent of design speed

READING NUMBER	3777
ROTOR TOTAL PRESSURE RATIO	1.239
STATOR TOTAL PRESSURE RATIO	0.976
ROTOR TOTAL TEMPERATURE RATIO	1.070
STATOR TOTAL TEMPERATURE RATIO	0.998
ROTOR ADIABATIC EFFICIENCY	0.900
ROTOR MOMENTUM-RISE EFFICIENCY	0.932
ROTOR HEAD-RISE COEFFICIENT	0.513
FLOW COEFFICIENT	0.409
AIRFLOW PER UNIT FRONTAL AREA	32.75
AIRFLOW PER UNIT ANNULUS AREA	90.97
AIRFLOW AT ORIFICE	6.64
AIRFLOW AT ROTOR INLET	6.83
AIRFLOW AT ROTOR OUTLET	7.19
AIRFLOW AT STATOR OUTLET	6.73
ROTATIVE SPEED	7347.2
PERCENT OF DESIGN SPEED	.80.1
COMPRESSOR PERFORMANCE	
STAGE TOTAL PRESSURE RATIO	1.210
STAGE TOTAL TEMPERATURE RATIO	1.069
STAGE ADIABATIC EFFICIENCY	0.816

(f) 70 Percent of design speed

READING NUMBER	3783	3782	3781	3780	3779
ROTOR TOTAL PRESSURE RATIO	1.121	1.150	1.161	1.169	1.178
STATOR TOTAL PRESSURE RATIO	0.971	0.986	0.989	0.989	0.984
ROTOR TOTAL TEMPERATURE RATIO	1.040	1.044	1.047	1.050	1.053
STATOR TOTAL TEMPERATURE RATIO	1.001	1.000	1.000	1.000	0.999
ROTOR ADIABATIC EFFICIENCY	0.837	0.924	0.928	0.923	0.905
ROTOR MOMENTUM-RISE EFFICIENCY	0.853	0.944	0.957	0.959	0.932
ROTOR HEAD-RISE COEFFICIENT	0.340	0.422	0.452	0.474	0.499
FLOW COEFFICIENT	0.641	0.584	0.527	0.460	0.407
AIRFLOW PER UNIT FRONTAL AREA	43.86	40.18	36.64	32.28	28.67
AIRFLOW PER UNIT ANNULUS AREA	121.83	111.60	101.78	89.66	79.63
AIRFLOW AT ORIFICE	8.89	8.14	7.43	6.54	5.81
AIRFLOW AT ROTOR INLET	9.15	8.39	7.64	6.73	5.99
AIRFLOW AT ROTOR OUTLET	8.87	8.24	7.55	6.76	6.20
AIRFLOW AT STATOR OUTLET	9.00	8.23	7.47	6.58	5.98
ROTATIVE SPEED	6449.2	6425.8	6431.5	6433.3	6438.6
PERCENT OF DESIGN SPEED	.70.3	70.1	70.1	70.2	70.2
COMPRESSOR PERFORMANCE					
STAGE TOTAL PRESSURE RATIO	1.088	1.134	1.148	1.157	1.159
STAGE TOTAL TEMPERATURE RATIO	1.040	1.044	1.046	1.049	1.052
STAGE ADIABATIC EFFICIENCY	0.606	0.825	0.867	0.861	0.826

TABLE 31. - Concluded.

(g) 60 Percent of design speed

READING NUMBER	3785
ROTOR TOTAL PRESSURE RATIO	1.129
STATOR TOTAL PRESSURE RATIO	0.988
ROTOR TOTAL TEMPERATURE RATIO	1.039
STATOR TOTAL TEMPERATURE RATIO	1.000
ROTOR ADIABATIC EFFICIENCY	0.908
ROTOR MOMENTUM-RISE EFFICIENCY	0.930
ROTOR HEAD-RISE COEFFICIENT	0.491
FLOW COEFFICIENT	0.401
AIRFLOW PER UNIT FRONTAL AREA	24.31
AIRFLOW PER UNIT ANNULUS AREA	67.54
AIRFLOW AT ORIFICE	4.93
AIRFLOW AT ROTOR INLET	5.08
AIRFLOW AT ROTOR OUTLET	5.26
AIRFLOW AT STATOR OUTLET	5.06
ROTATIVE SPEED	5517.5
PERCENT OF DESIGN SPEED	60.2

COMPRESSOR PERFORMANCE

STAGE TOTAL PRESSURE RATIO	1.115
STAGE TOTAL TEMPERATURE RATIO	1.038
STAGE ADIABATIC EFFICIENCY	0.822

(h) 50 Percent of design speed

READING NUMBER	3788
ROTOR TOTAL PRESSURE RATIO	1.087
STATOR TOTAL PRESSURE RATIO	0.992
ROTOR TOTAL TEMPERATURE RATIO	1.027
STATOR TOTAL TEMPERATURE RATIO	1.000
ROTOR ADIABATIC EFFICIENCY	0.906
ROTOR MOMENTUM-RISE EFFICIENCY	0.928
ROTOR HEAD-RISE COEFFICIENT	0.477
FLOW COEFFICIENT	0.402
AIRFLOW PER UNIT FRONTAL AREA	20.44
AIRFLOW PER UNIT ANNULUS AREA	56.78
AIRFLOW AT ORIFICE	4.14
AIRFLOW AT ROTOR INLET	4.27
AIRFLOW AT ROTOR OUTLET	4.37
AIRFLOW AT STATOR OUTLET	4.21
ROTATIVE SPEED	4606.9
PERCENT OF DESIGN SPEED	50.2

COMPRESSOR PERFORMANCE

STAGE TOTAL PRESSURE RATIO	1.079
STAGE TOTAL TEMPERATURE RATIO	1.027
STAGE ADIABATIC EFFICIENCY	0.810

TABLE 32. - OVERALL PERFORMANCE OF STAGE 28D-22

(a) 120 Percent of design speed

READING NUMBER	0209	0210	0211	0212	0213	0208
ROTOR TOTAL PRESSURE RATIO	1.349	1.456	1.516	1.539	1.555	1.568
STATOR TOTAL PRESSURE RATIO	0.945	0.967	0.970	0.968	0.969	0.966
ROTOR TOTAL TEMPERATURE RATIO	1.121	1.134	1.141	1.144	1.147	1.151
STATOR TOTAL TEMPERATURE RATIO	0.996	0.996	0.996	0.995	0.996	0.997
ROTOR ADIABATIC EFFICIENCY	0.737	0.848	0.897	0.910	0.914	0.907
ROTOR MOMENTUM-RISE EFFICIENCY	0.749	0.866	0.920	0.939	0.940	0.923
ROTOR HEAD-RISE COEFFICIENT	0.337	0.432	0.487	0.507	0.523	0.535
FLOW COEFFICIENT	0.586	0.582	0.567	0.545	0.514	0.485
AIRFLOW PER UNIT FRONTAL AREA	64.27	63.89	62.62	60.76	58.00	55.21
AIRFLOW PER UNIT ANNULUS AREA	178.54	177.48	173.96	168.77	161.12	153.35
AIRFLOW AT ORIFICE	13.03	12.95	12.69	12.31	11.76	11.19
AIRFLOW AT ROTOR INLET	13.23	13.15	12.87	12.50	11.93	11.37
AIRFLOW AT ROTOR OUTLET	13.41	13.39	13.21	12.93	12.57	12.11
AIRFLOW AT STATOR OUTLET	13.00	12.80	12.26	11.83	11.60	11.16
ROTATIVE SPEED	11031.4	11030.1	11000.9	11006.4	10986.4	10980.6
PERCENT OF DESIGN SPEED	120.3	120.3	120.0	120.0	119.8	119.7
COMPRESSOR PERFORMANCE						
STAGE TOTAL PRESSURE RATIO	1.276	1.408	1.470	1.490	1.506	1.514
STAGE TOTAL TEMPERATURE RATIO	1.117	1.129	1.136	1.138	1.142	1.148
STAGE ADIABATIC EFFICIENCY	0.618	0.797	0.855	0.872	0.872	0.850

(b) 110 Percent of design speed

READING NUMBER	0216	0217	0215
ROTOR TOTAL PRESSURE RATIO	1.333	1.429	1.465
STATOR TOTAL PRESSURE RATIO	0.946	0.975	0.968
ROTOR TOTAL TEMPERATURE RATIO	1.101	1.115	1.125
STATOR TOTAL TEMPERATURE RATIO	0.997	0.997	0.997
ROTOR ADIABATIC EFFICIENCY	0.850	0.935	0.921
ROTOR MOMENTUM-RISE EFFICIENCY	0.851	0.958	0.943
ROTOR HEAD-RISE COEFFICIENT	0.382	0.485	0.524
FLOW COEFFICIENT	0.614	0.556	0.476
AIRFLOW PER UNIT FRONTAL AREA	62.11	57.48	50.55
AIRFLOW PER UNIT ANNULUS AREA	172.53	159.68	140.41
AIRFLOW AT ORIFICE	12.59	11.65	10.25
AIRFLOW AT ROTOR INLET	12.78	11.83	10.41
AIRFLOW AT ROTOR OUTLET	13.10	12.12	10.95
AIRFLOW AT STATOR OUTLET	12.55	11.39	9.96
ROTATIVE SPEED	10047.7	10046.8	10062.6
PERCENT OF DESIGN SPEED	109.6	109.6	109.7
COMPRESSOR PERFORMANCE			
STAGE TOTAL PRESSURE RATIO	1.260	1.394	1.418
STAGE TOTAL TEMPERATURE RATIO	1.098	1.112	1.121
STAGE ADIABATIC EFFICIENCY	0.701	0.891	0.865

(c) 100 Percent of design speed

READING NUMBER	0189	0190	0191	0192	0193	0203
ROTOR TOTAL PRESSURE RATIO	1.269	1.312	1.340	1.347	1.359	1.374
STATOR TOTAL PRESSURE RATIO	0.945	0.966	0.974	0.977	0.978	0.973
ROTOR TOTAL TEMPERATURE RATIO	1.082	1.088	1.093	1.095	1.099	1.105
STATOR TOTAL TEMPERATURE RATIO	0.998	0.998	0.997	0.998	0.998	0.997
ROTOR ADIABATIC EFFICIENCY	0.858	0.916	0.938	0.935	0.921	0.904
ROTOR MOMENTUM-RISE EFFICIENCY	0.872	0.926	0.958	0.965	0.957	0.930
ROTOR HEAD-RISE COEFFICIENT	0.372	0.427	0.465	0.475	0.490	0.509
FLOW COEFFICIENT	0.627	0.610	0.575	0.535	0.491	0.453
AIRFLOW PER UNIT FRONTAL AREA	58.74	57.49	54.74	51.44	47.80	44.57
AIRFLOW PER UNIT ANNULUS AREA	163.17	159.69	152.06	142.88	132.77	123.82
AIRFLOW AT ORIFICE	11.91	11.65	11.10	10.43	9.69	9.03
AIRFLOW AT ROTOR INLET	12.08	11.82	11.27	10.61	9.86	9.21
AIRFLOW AT ROTOR OUTLET	12.25	12.04	11.58	10.89	10.15	9.54
AIRFLOW AT STATOR OUTLET	11.81	11.46	10.91	10.15	9.31	8.79
ROTATIVE SPEED	9149.8	9163.6	9155.5	9156.8	9168.9	9198.8
PERCENT OF DESIGN SPEED	99.8	99.9	99.8	99.9	100.0	100.3
COMPRESSOR PERFORMANCE						
STAGE TOTAL PRESSURE RATIO	1.199	1.267	1.305	1.316	1.328	1.337
STAGE TOTAL TEMPERATURE RATIO	1.080	1.086	1.090	1.092	1.097	1.102
STAGE ADIABATIC EFFICIENCY	0.665	0.815	0.883	0.886	0.870	0.847



TABLE 32. - Continued.

(d) 90 Percent of design speed

READING NUMBER	0195	0200	0221	0222	0223
ROTOR TOTAL PRESSURE RATIO	1.214	1.251	1.266	1.274	1.292
STATOR TOTAL PRESSURE RATIO	0.946	0.968	0.979	0.982	0.975
ROTOR TOTAL TEMPERATURE RATIO	1.065	1.071	1.074	1.077	1.084
STATOR TOTAL TEMPERATURE RATIO	0.999	0.998	0.998	0.998	0.997
ROTOR ADIABATIC EFFICIENCY	0.879	0.933	0.941	0.933	0.903
ROTOR MOMENTUM-RISE EFFICIENCY	0.893	0.943	0.962	0.962	0.942
ROTOR HEAD-RISE COEFFICIENT	0.365	0.419	0.454	0.469	0.497
FLOW COEFFICIENT	0.640	0.614	0.553	0.503	0.444
AIRFLOW PER UNIT FRONTAL AREA	54.90	53.22	48.15	44.22	39.49
AIRFLOW PER UNIT ANNULUS AREA	152.51	147.84	133.76	122.82	109.68
AIRFLOW AT ORIFICE	11.13	10.79	9.76	8.96	8.00
AIRFLOW AT ROTOR INLET	11.30	10.98	9.96	9.14	8.17
AIRFLOW AT ROTOR OUTLET	11.42	11.11	10.17	9.32	8.49
AIRFLOW AT STATOR OUTLET	11.03	10.61	9.51	8.63	7.51
ROTATIVE SPEED	8256.2	8316.6	8225.1	8208.6	8225.7
PERCENT OF DESIGN SPEED	90.0	90.7	89.7	89.5	89.7

COMPRESSOR PERFORMANCE

STAGE TOTAL PRESSURE RATIO	1.149	1.211	1.239	1.251	1.259
STAGE TOTAL TEMPERATURE RATIO	1.064	1.069	1.072	1.075	1.081
STAGE ADIABATIC EFFICIENCY	0.636	0.811	0.884	0.882	0.837

(e) 80 Percent of design speed

READING NUMBER	0225
ROTOR TOTAL PRESSURE RATIO	1.227
STATOR TOTAL PRESSURE RATIO	0.979
ROTOR TOTAL TEMPERATURE RATIO	1.066
STATOR TOTAL TEMPERATURE RATIO	0.998
ROTOR ADIABATIC EFFICIENCY	0.907
ROTOR MOMENTUM-RISE EFFICIENCY	0.945
ROTOR HEAD-RISE COEFFICIENT	0.489
FLOW COEFFICIENT	0.433
AIRFLOW PER UNIT FRONTAL AREA	34.74
AIRFLOW PER UNIT ANNULUS AREA	96.49
AIRFLOW AT ORIFICE	7.04
AIRFLOW AT ROTOR INLET	7.18
AIRFLOW AT ROTOR OUTLET	7.48
AIRFLOW AT STATOR OUTLET	6.62
ROTATIVE SPEED	7327.6
PERCENT OF DESIGN SPEED	79.9

COMPRESSOR PERFORMANCE

STAGE TOTAL PRESSURE RATIO	1.202
STAGE TOTAL TEMPERATURE RATIO	1.064
STAGE ADIABATIC EFFICIENCY	0.841

(f) 70 Percent of design speed

READING NUMBER	0236	0234	0233	0230	0229	0228
ROTOR TOTAL PRESSURE RATIO	1.122	1.141	1.151	1.155	1.162	1.171
STATOR TOTAL PRESSURE RATIO	0.959	0.973	0.984	0.988	0.988	0.984
ROTOR TOTAL TEMPERATURE RATIO	1.037	1.041	1.043	1.045	1.047	1.051
STATOR TOTAL TEMPERATURE RATIO	1.000	1.000	0.999	0.999	0.999	0.999
ROTOR ADIABATIC EFFICIENCY	0.896	0.931	0.951	0.930	0.934	0.911
ROTOR MOMENTUM-RISE EFFICIENCY	0.923	0.967	0.976	0.973	0.963	0.947
ROTOR HEAD-RISE COEFFICIENT	0.345	0.390	0.421	0.434	0.452	0.481
FLOW COEFFICIENT	0.655	0.619	0.572	0.521	0.475	0.428
AIRFLOW PER UNIT FRONTAL AREA	45.03	43.03	39.85	36.56	33.52	30.29
AIRFLOW PER UNIT ANNULUS AREA	125.10	119.53	110.69	101.56	93.12	84.13
AIRFLOW AT ORIFICE	9.13	8.72	8.08	7.41	6.79	6.14
AIRFLOW AT ROTOR INLET	9.29	8.89	8.24	7.57	6.94	6.26
AIRFLOW AT ROTOR OUTLET	9.26	8.94	8.33	7.69	7.07	6.51
AIRFLOW AT STATOR OUTLET	8.91	8.49	7.83	7.15	6.47	5.68
ROTATIVE SPEED	6429.7	6473.7	6443.3	6448.1	6439.1	6417.2
PERCENT OF DESIGN SPEED	70.1	70.6	70.3	70.3	70.2	70.0

COMPRESSOR PERFORMANCE

STAGE TOTAL PRESSURE RATIO	1.076	1.110	1.132	1.141	1.148	1.152
STAGE TOTAL TEMPERATURE RATIO	1.037	1.041	1.042	1.045	1.046	1.049
STAGE ADIABATIC EFFICIENCY	0.573	0.739	0.849	0.864	0.869	0.840

TABLE 32. - Concluded.

(g) 60 Percent of design speed

READING NUMBER	0238
ROTOR TOTAL PRESSURE RATIO	1.119
STATOR TOTAL PRESSURE RATIO	0.991
ROTOR TOTAL TEMPERATURE RATIO	1.036
STATOR TOTAL TEMPERATURE RATIO	1.000
ROTOR ADIABATIC EFFICIENCY	0.907
ROTOR MOMENTUM-RISE EFFICIENCY	0.942
ROTOR HEAD-RISE COEFFICIENT	0.459
FLOW COEFFICIENT	0.418
AIRFLOW PER UNIT FRONTAL AREA	25.38
AIRFLOW PER UNIT ANNULUS AREA	70.51
AIRFLOW AT ORIFICE	5.14
AIRFLOW AT ROTOR INLET	5.26
AIRFLOW AT ROTOR OUTLET	5.35
AIRFLOW AT STATOR OUTLET	4.65
ROTATIVE SPEED	5482.6
PERCENT OF DESIGN SPEED	59.8

COMPRESSOR PERFORMANCE

STAGE TOTAL PRESSURE RATIO	1.108
STAGE TOTAL TEMPERATURE RATIO	1.036
STAGE ADIABATIC EFFICIENCY	0.822

(h) 50 Percent of design speed

READING NUMBER	0240
ROTOR TOTAL PRESSURE RATIO	1.083
STATOR TOTAL PRESSURE RATIO	0.991
ROTOR TOTAL TEMPERATURE RATIO	1.025
STATOR TOTAL TEMPERATURE RATIO	1.000
ROTOR ADIABATIC EFFICIENCY	0.912
ROTOR MOMENTUM-RISE EFFICIENCY	0.953
ROTOR HEAD-RISE COEFFICIENT	0.462
FLOW COEFFICIENT	0.406
AIRFLOW PER UNIT FRONTAL AREA	20.98
AIRFLOW PER UNIT ANNULUS AREA	58.27
AIRFLOW AT ORIFICE	4.25
AIRFLOW AT ROTOR INLET	4.29
AIRFLOW AT ROTOR OUTLET	4.49
AIRFLOW AT STATOR OUTLET	3.72
ROTATIVE SPEED	4583.8
PERCENT OF DESIGN SPEED	50.0

COMPRESSOR PERFORMANCE

STAGE TOTAL PRESSURE RATIO	1.074
STAGE TOTAL TEMPERATURE RATIO	1.025
STAGE ADIABATIC EFFICIENCY	0.812

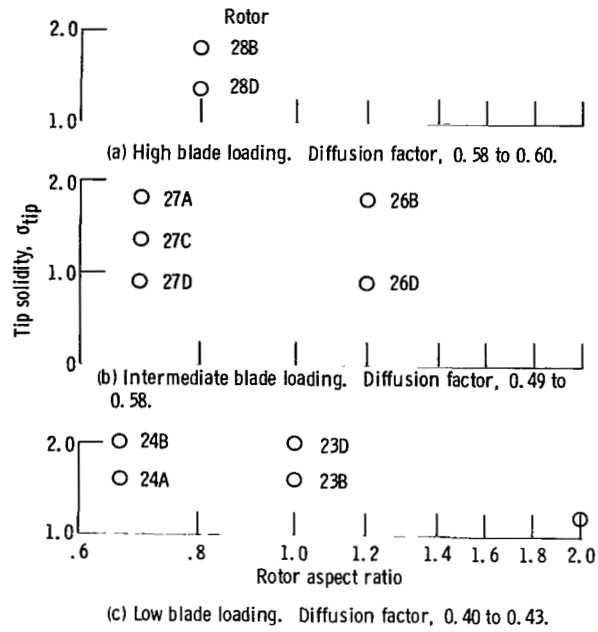

Figure 1. - Compressor middle stages - matrix of rotors tested.

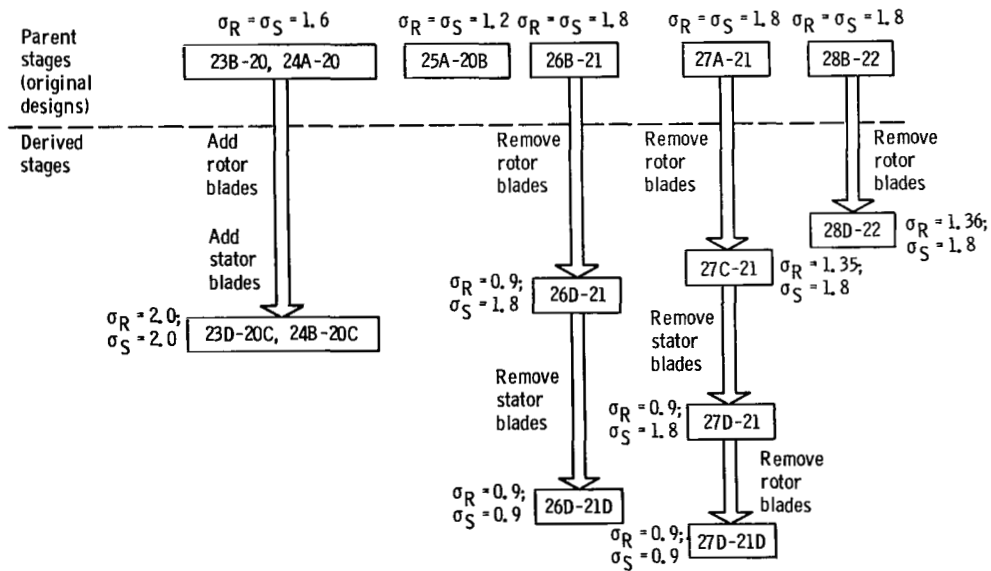

Figure 2. - Evolution of test stages, where σ_R denotes rotor tip solidity and σ_S denotes stator tip solidity.

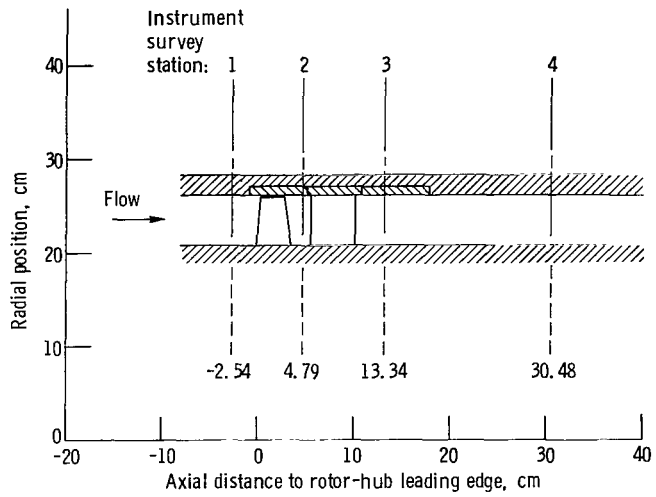

Figure 3. - Flowpath and instrumentation locations for stages 23.

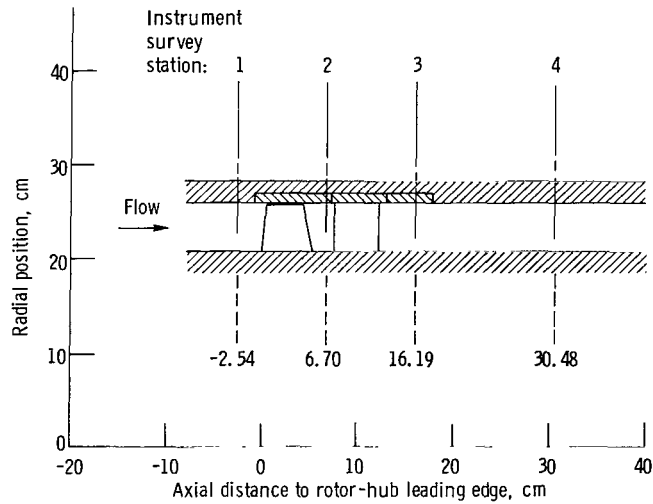

Figure 4. - Flowpath and instrumentation locations for stages 24.

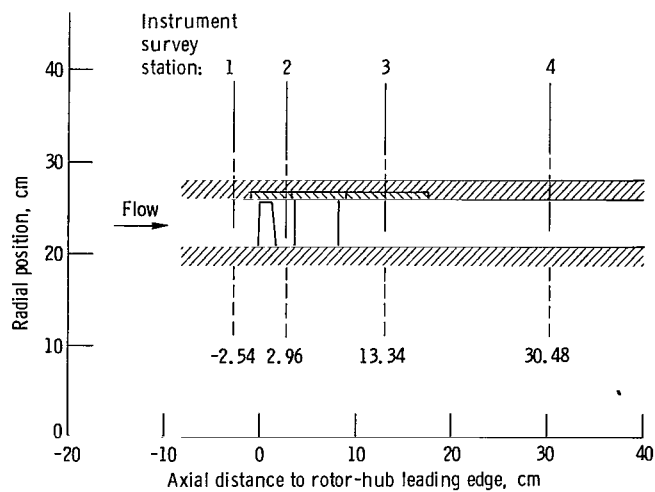

Figure 5. - Flowpath and instrumentation locations for stage 25A-20B.

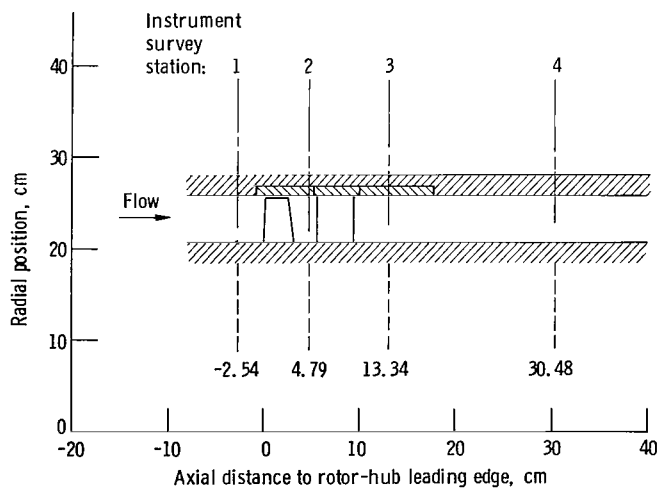

Figure 6. - Flowpath and instrumentation locations for stages 26.

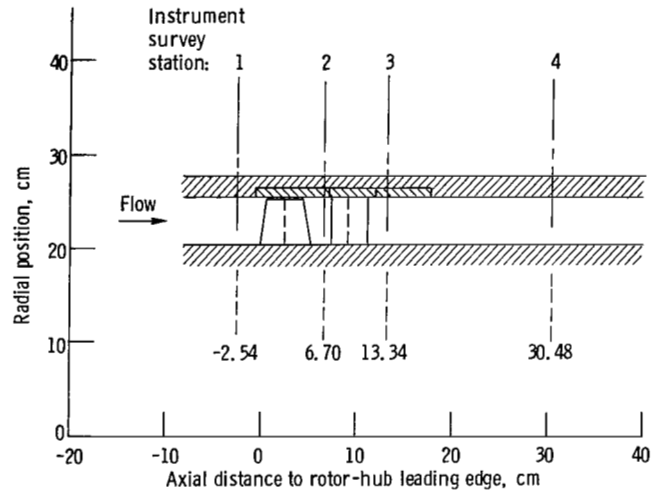

Figure 7. - Flowpath and instrumentation locations for stages 27.

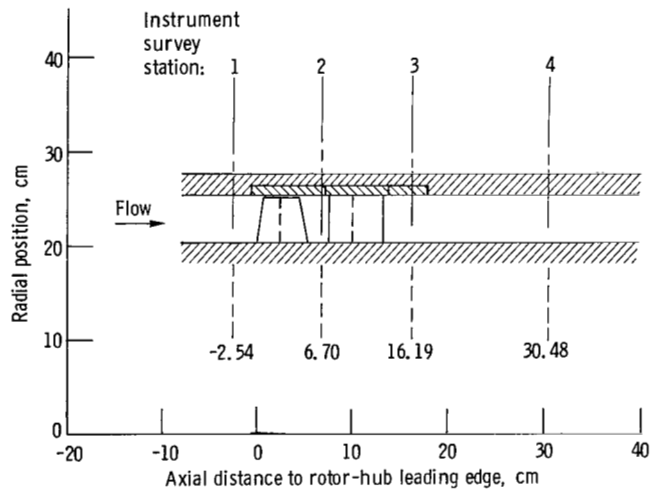

Figure 8. - Flowpath and instrumentation locations for stages 28.

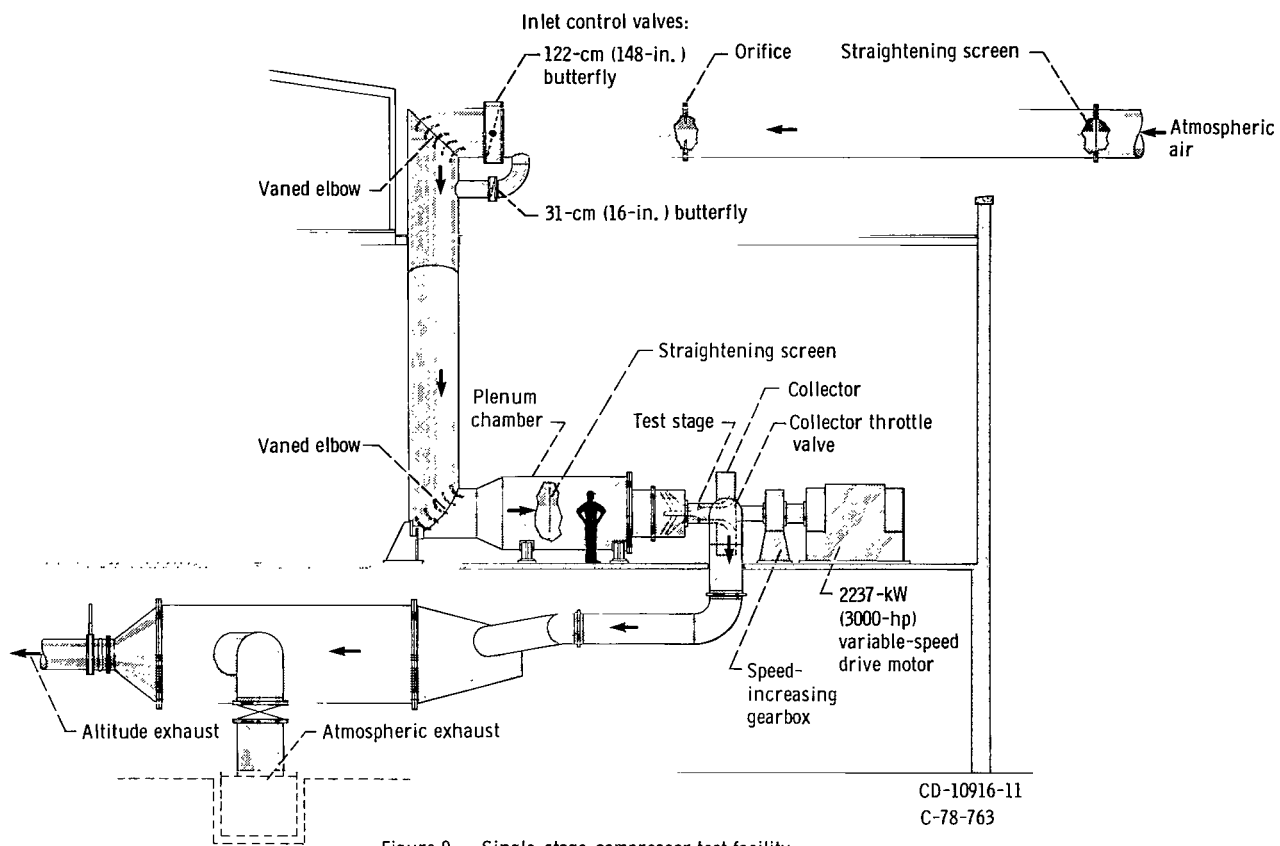
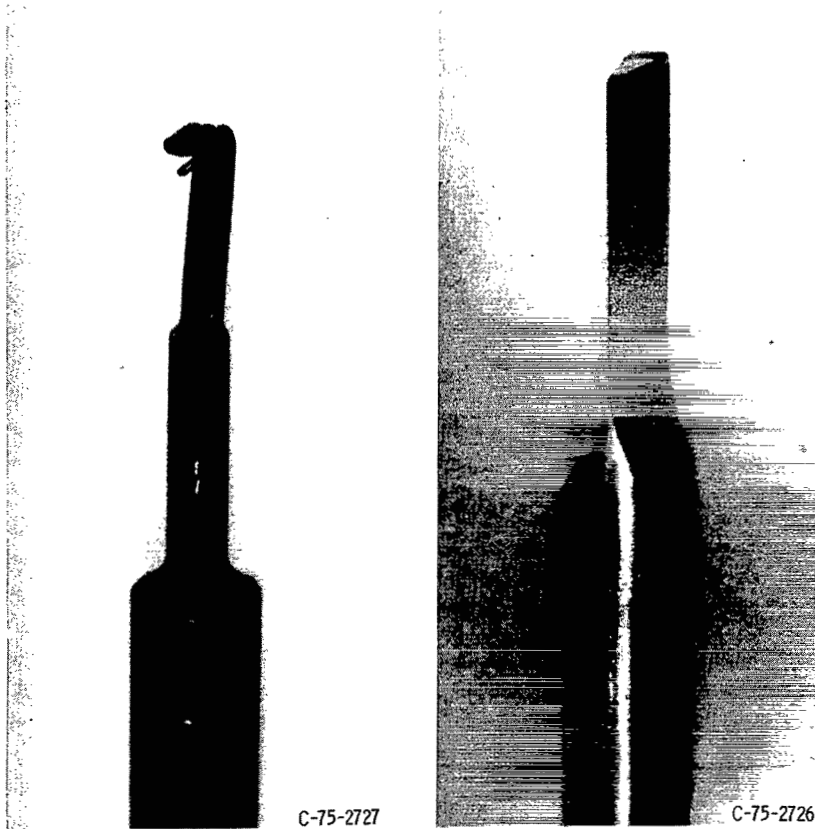

Figure 9. - Single-stage-compressor test facility.



(a) Cobra probe.

(b) 18° Wedge probe.

Figure 10. - Probes used.

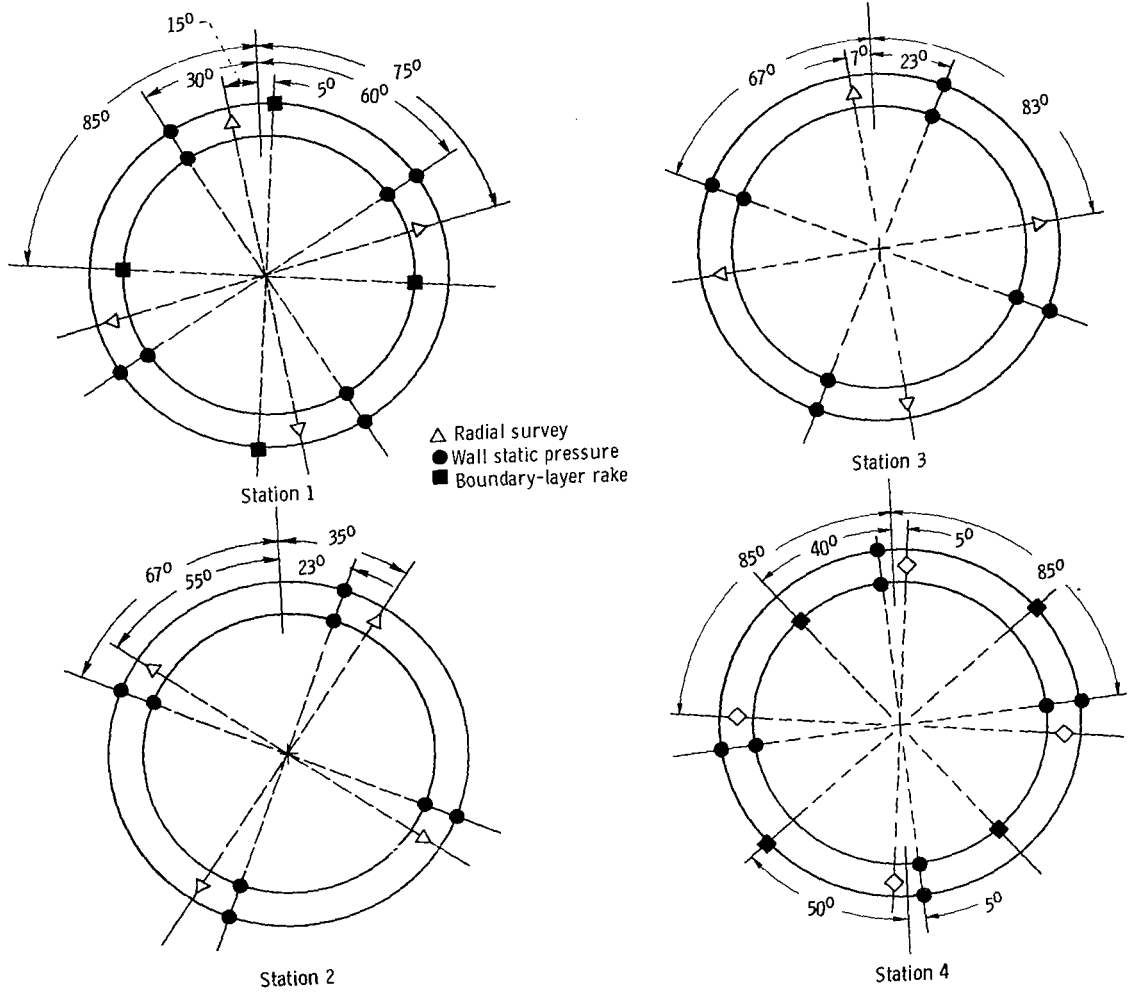

Figure 11. - Angular positions of instrumentation, looking downstream - stage 25A-20B.

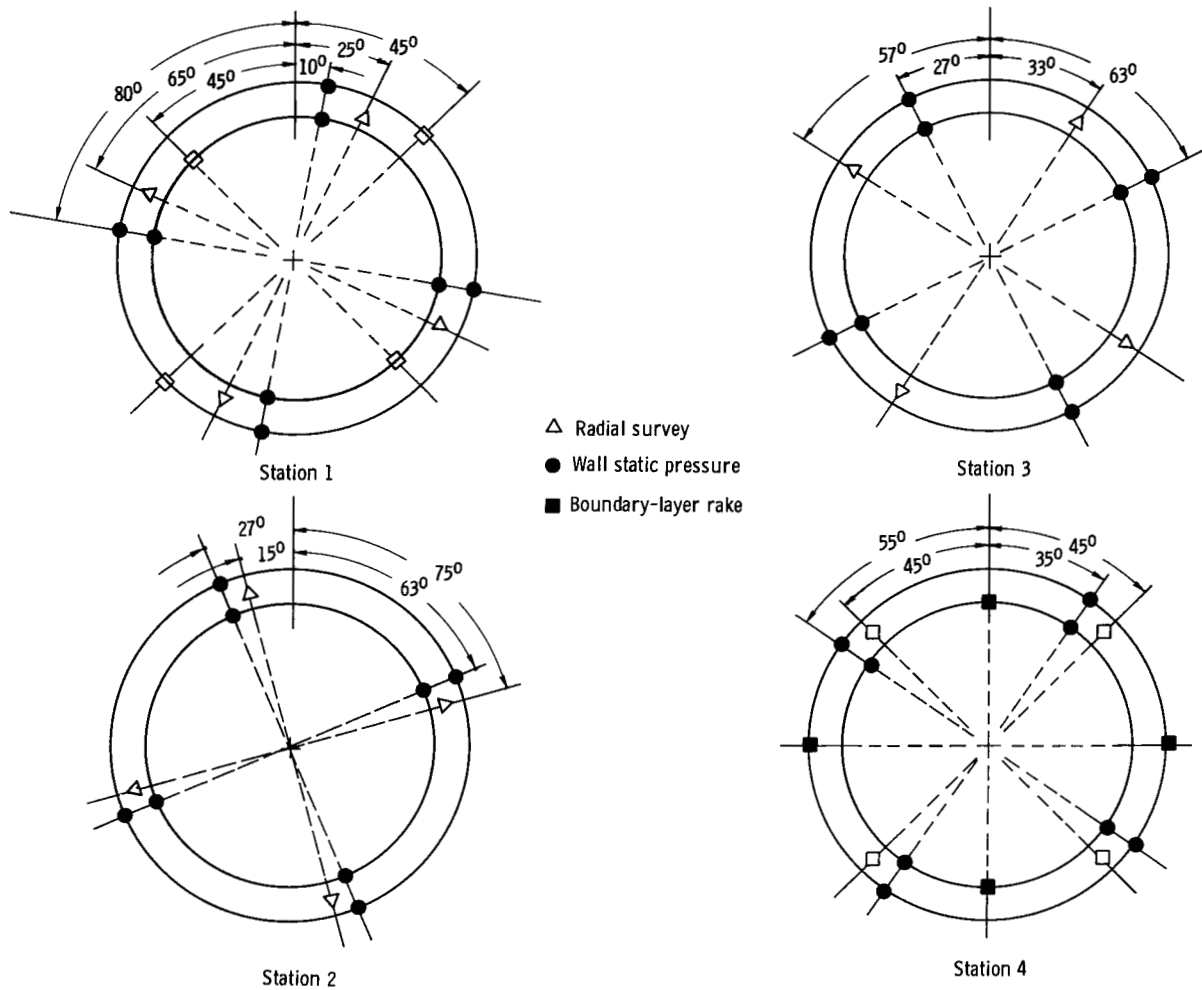
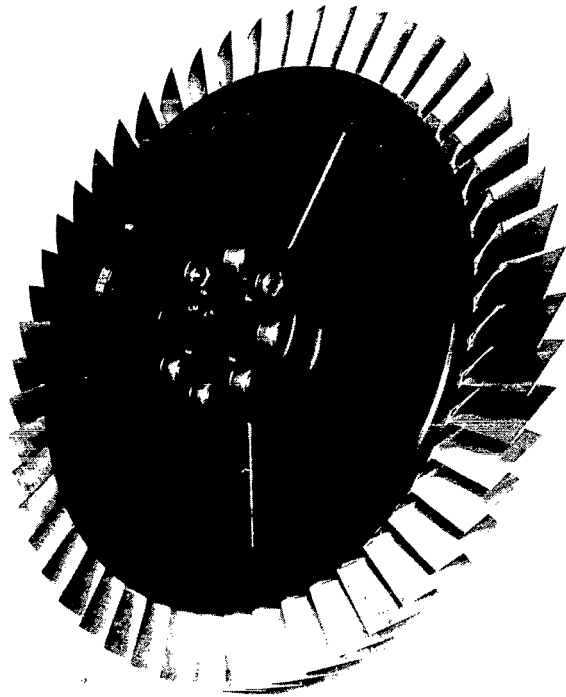
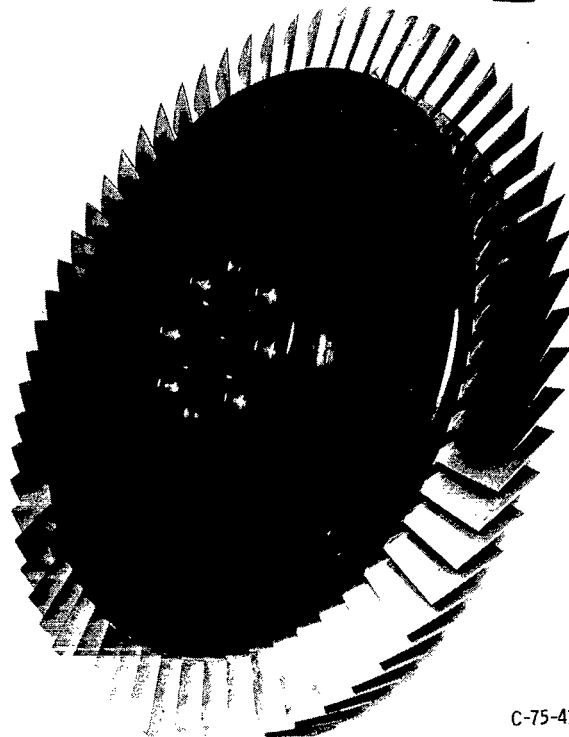

Figure 12. - Angular positions of instrumentation, looking downstream - all stages except 25A-20B.



C-75-3673

Figure 13. - Rotor 23B.



C-75-4175

Figure 14. - Rotor 23D.

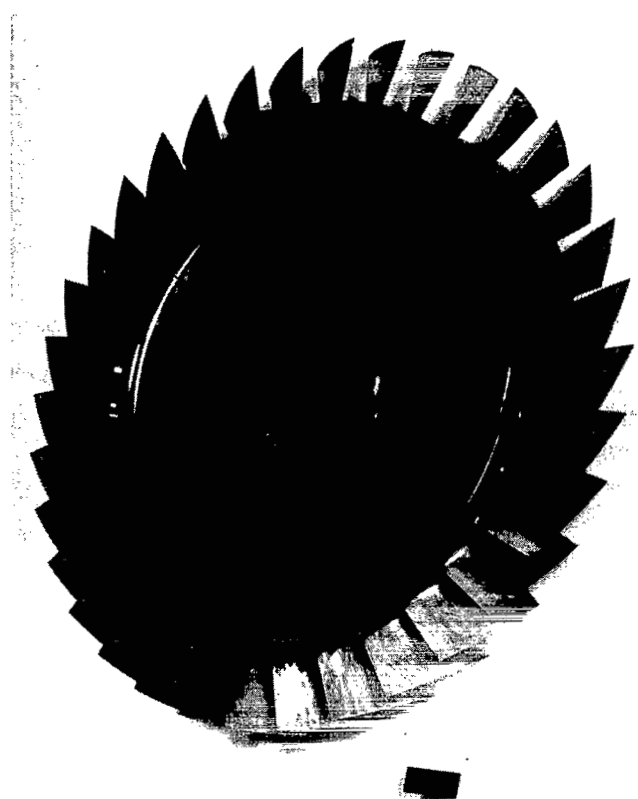

C-76-2678

Figure 15. - Rotor 24A.

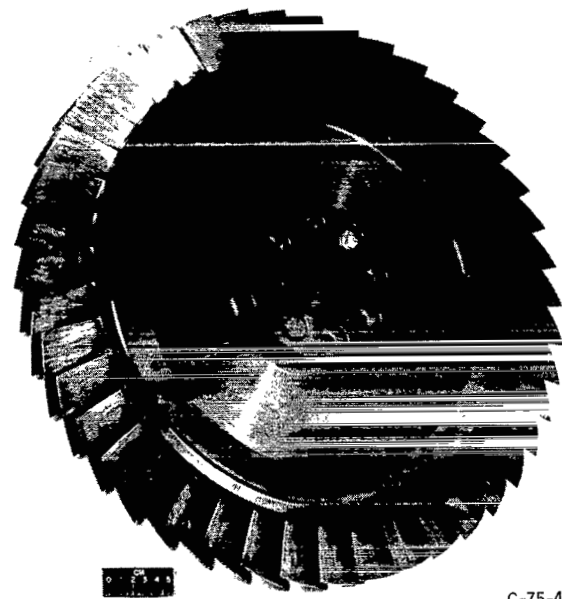

C-75-4045

Figure 16. - Rotor 24B.

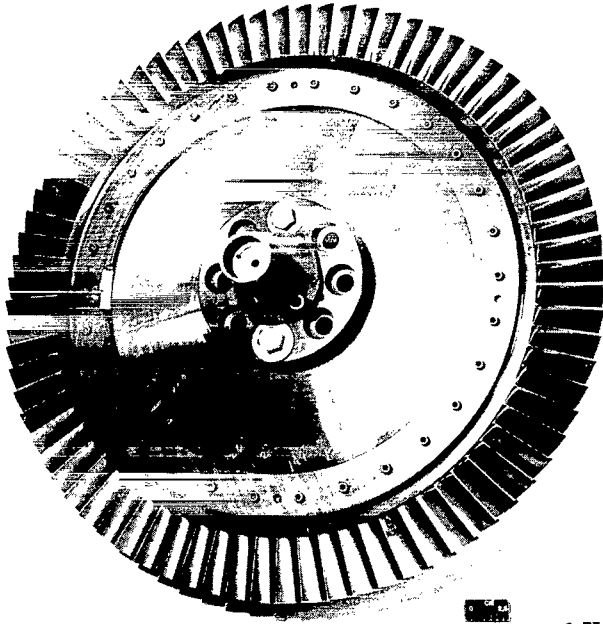

C-75-2730

Figure 17. - Rotor 25A.

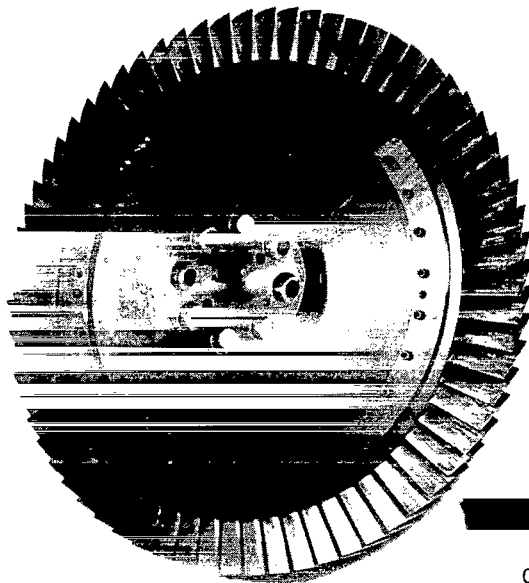

C-75-4438

Figure 18. - Rotor 26B.

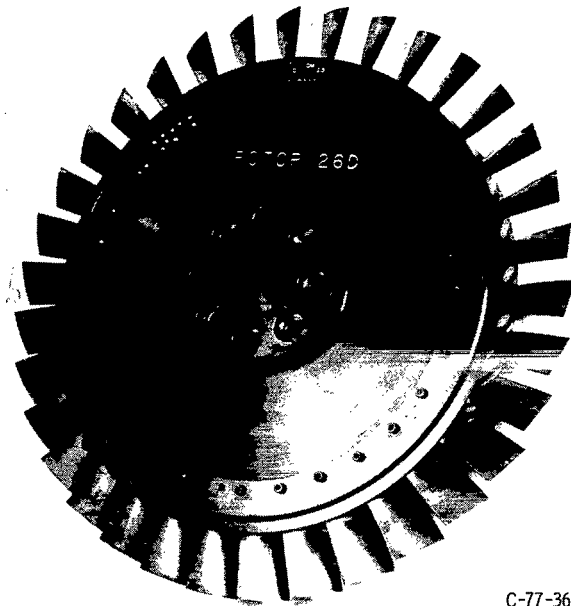

C-77-3623

Figure 19. - Rotor 26D.

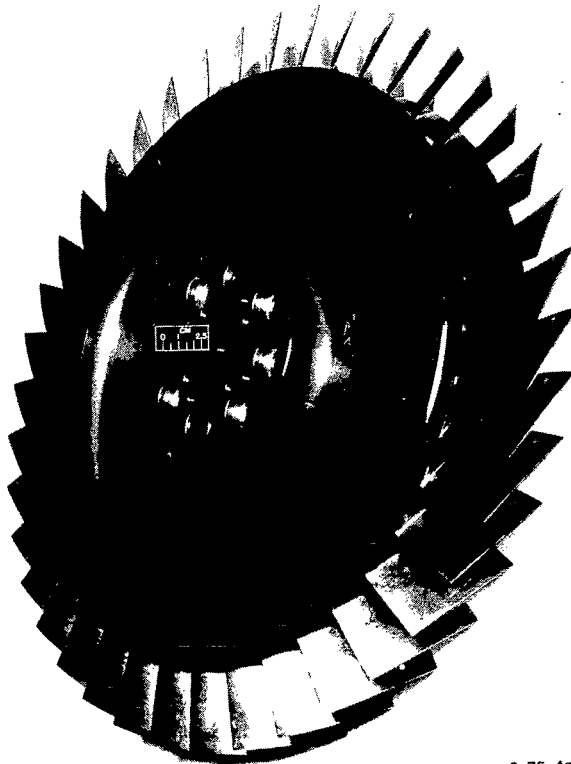

C-75-4283

Figure 20. - Rotor 27A.



C-77-3132

Figure 21. - Rotor 27C.

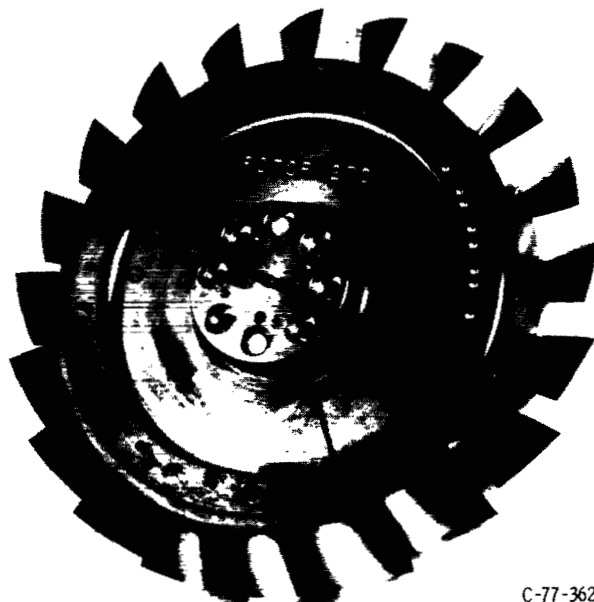

C-77-3622

Figure 22. - Rotor 27D.

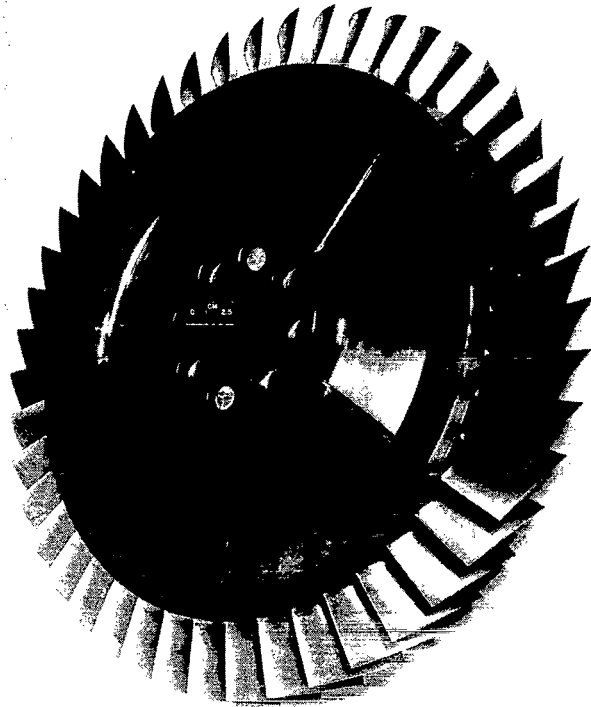

C-77-3778

Figure 23. - Rotor 28B.

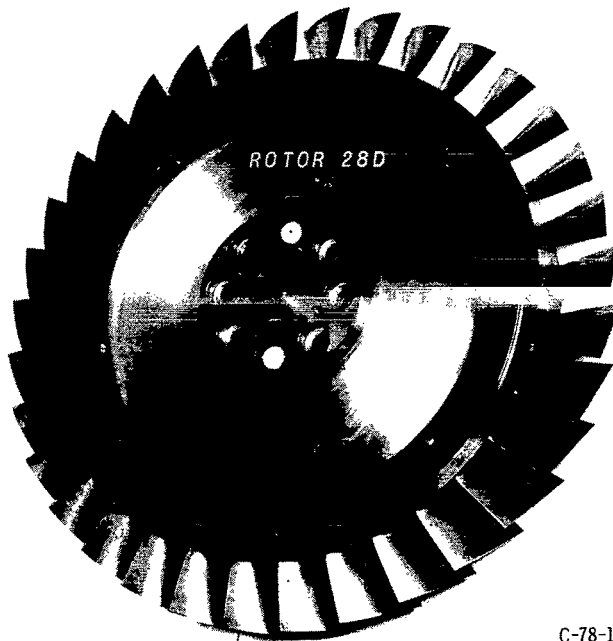

C-78-162

Figure 24. - Rotor 28D.

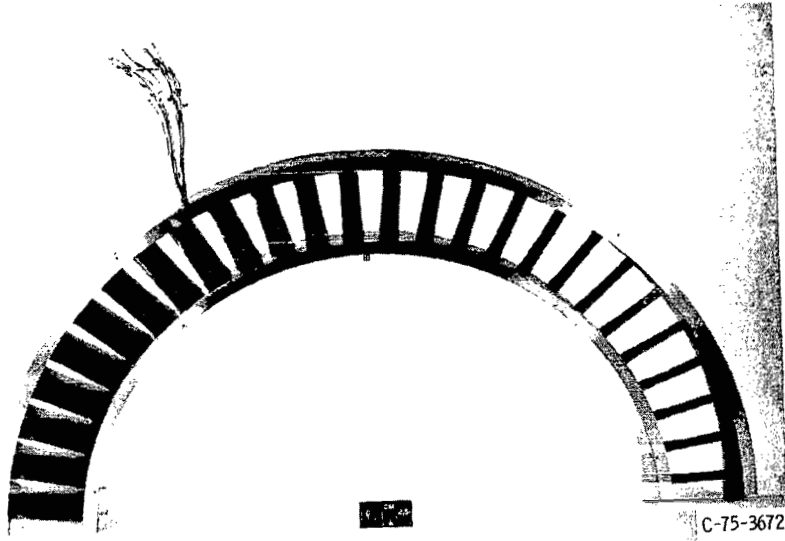

Figure 25. - Stator 20.

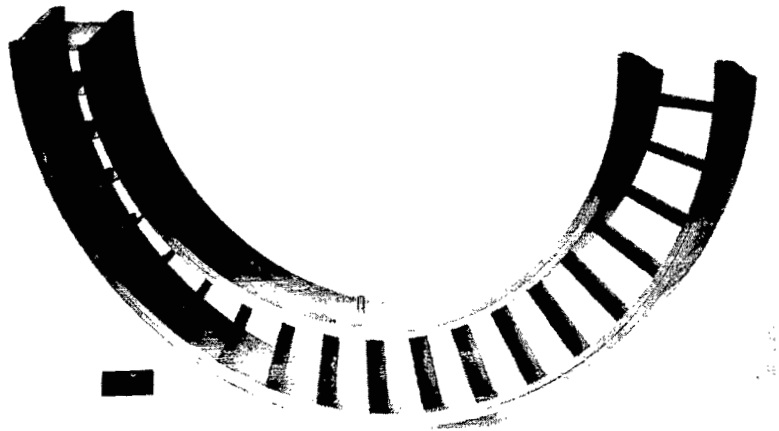
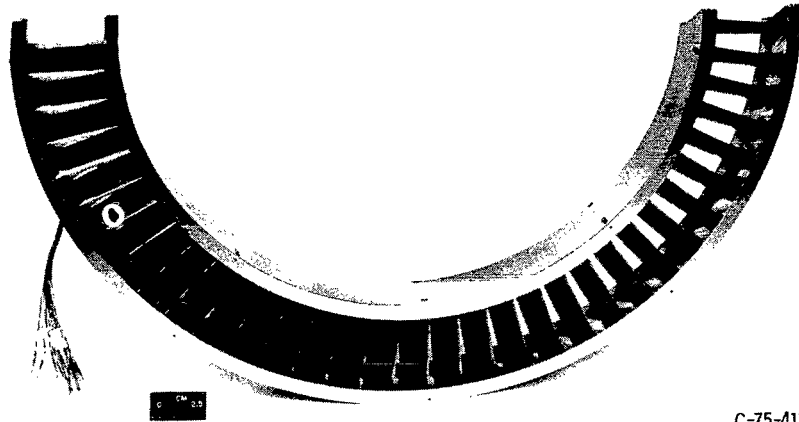
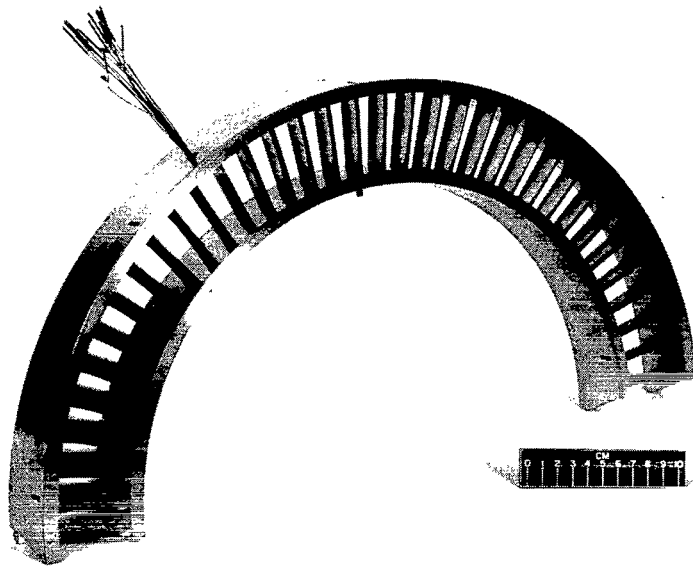

Figure 26. - Stator 20B.



C-75-4176

Figure 27. - Stator 20C.



C-75-4437

Figure 28. - Stator 21.

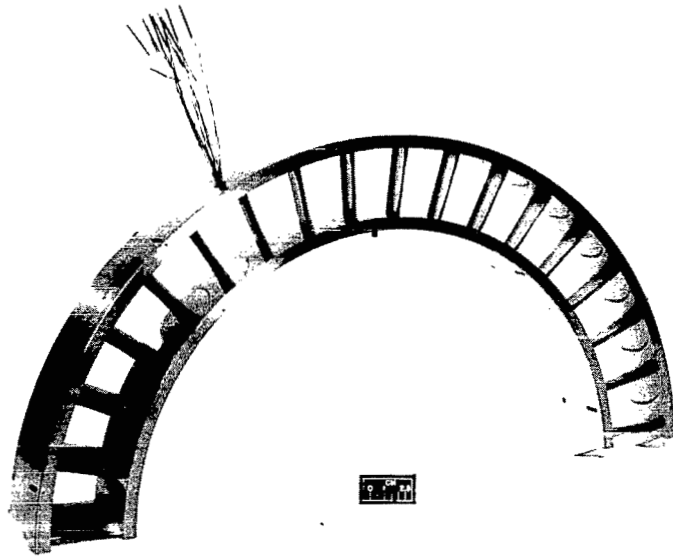

C-78-163

Figure 29. - Stator 21D.

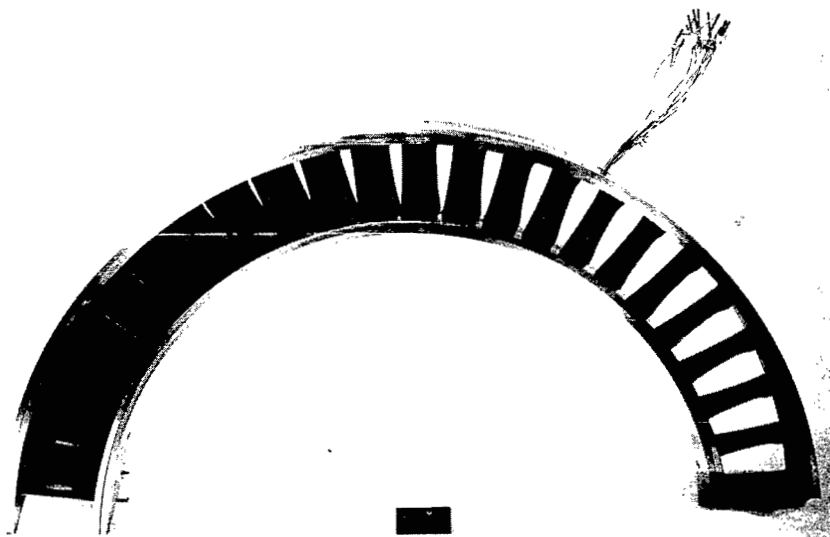

C-75-3776

Figure 30. - Stator 22.

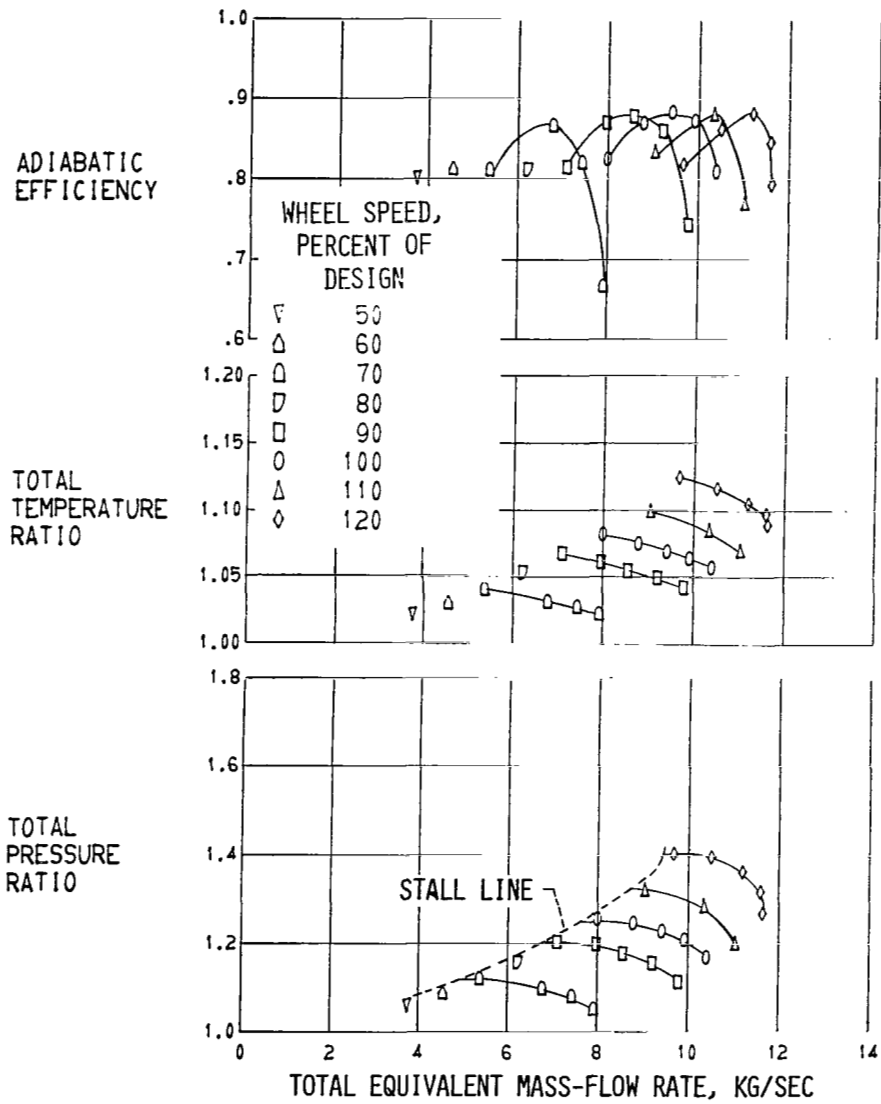

Figure 31. - Overall performance of stage 23B-20.

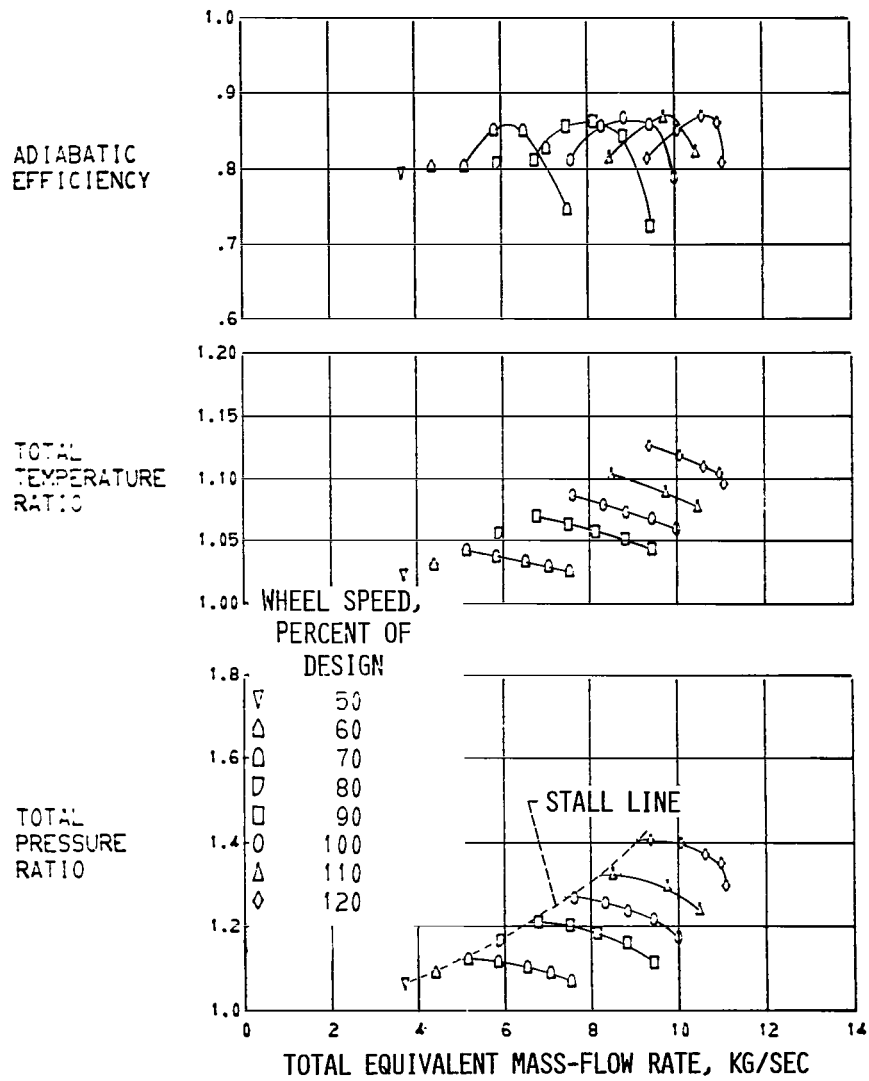

Figure 32. - Overall performance of stage 23D-20C.

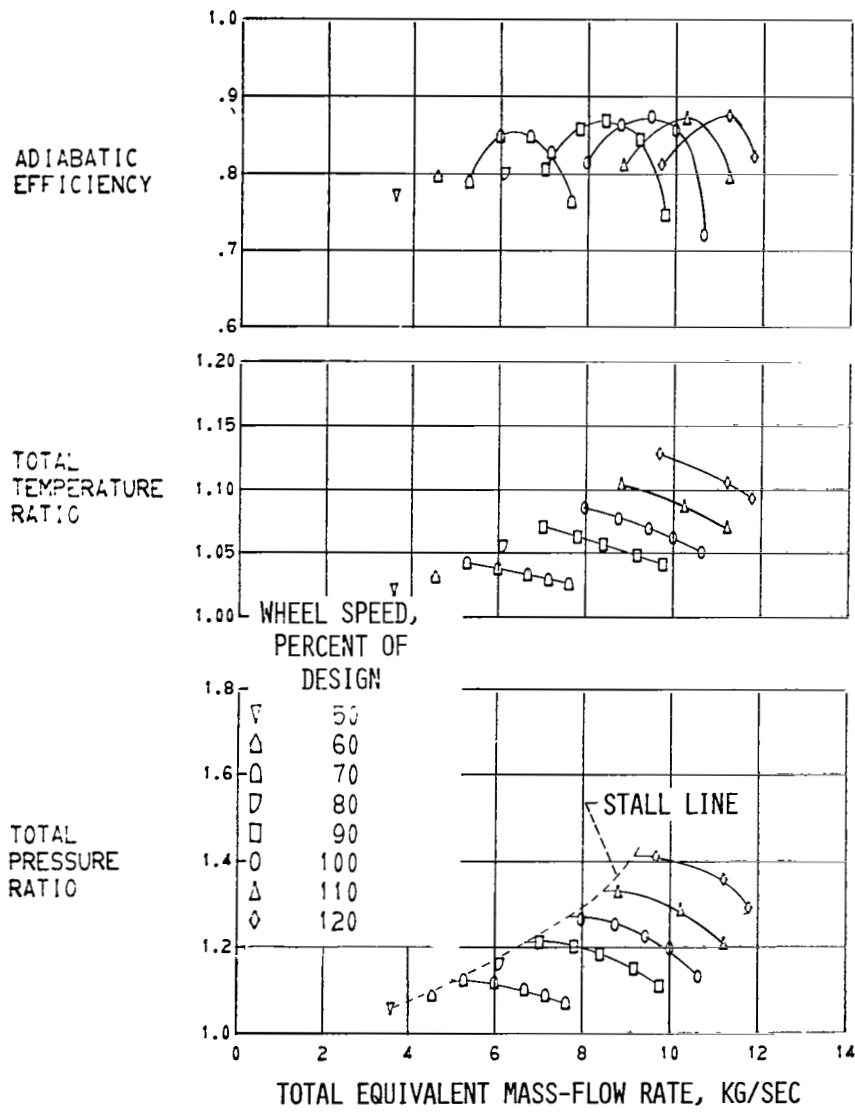

Figure 33. - Overall performance of stage 24A-20.

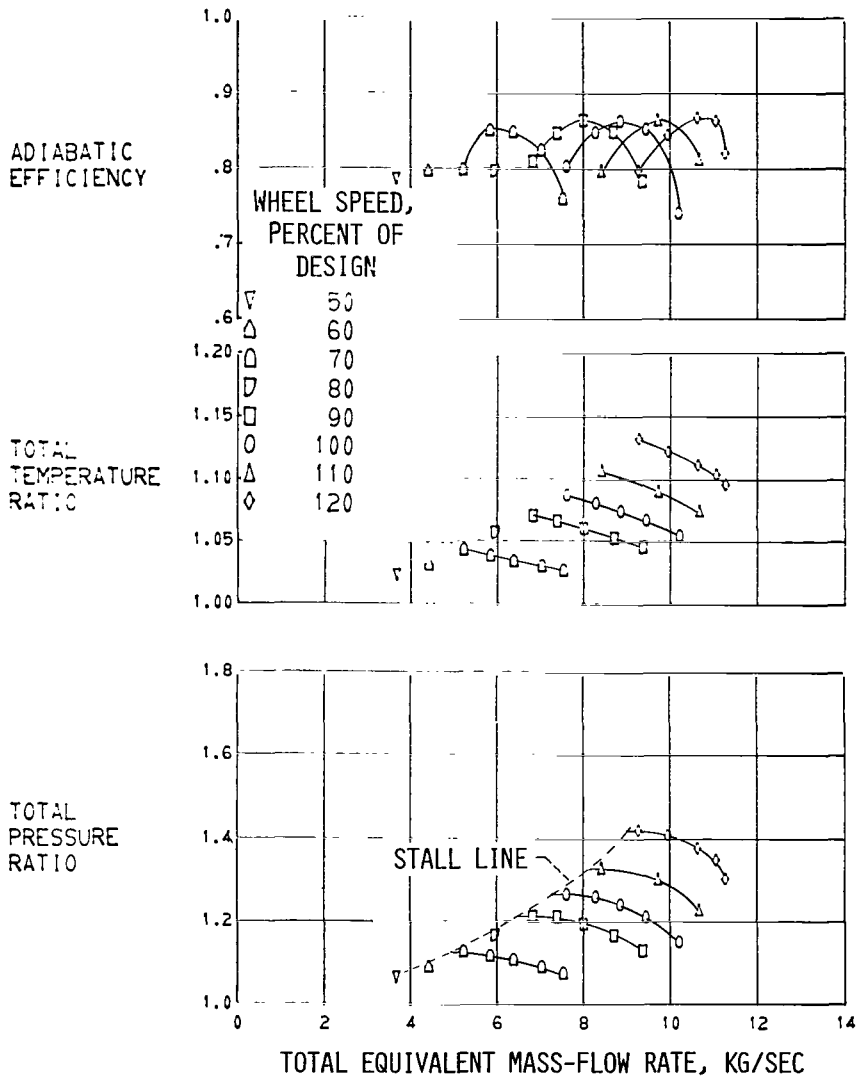

Figure 34. - Overall performance of stage 24B-20C.

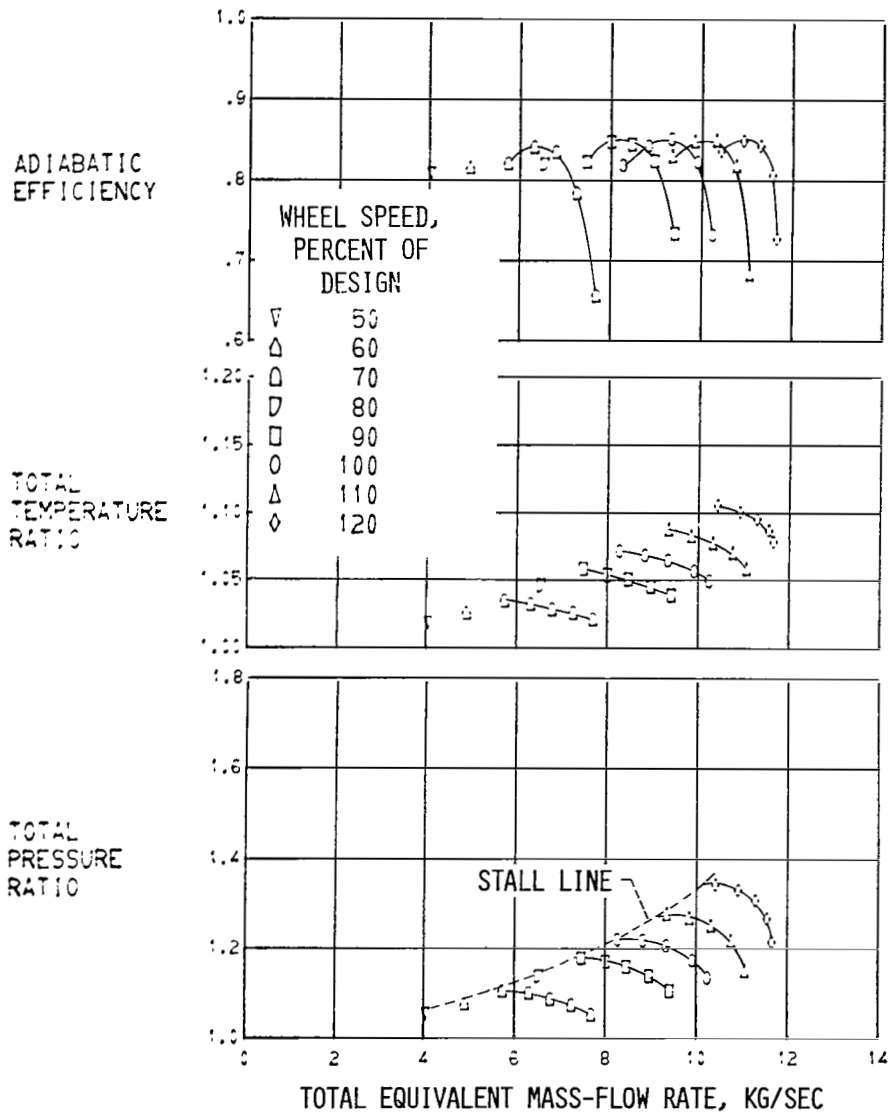

Figure 35. - Overall performance of stage 25A-20B.

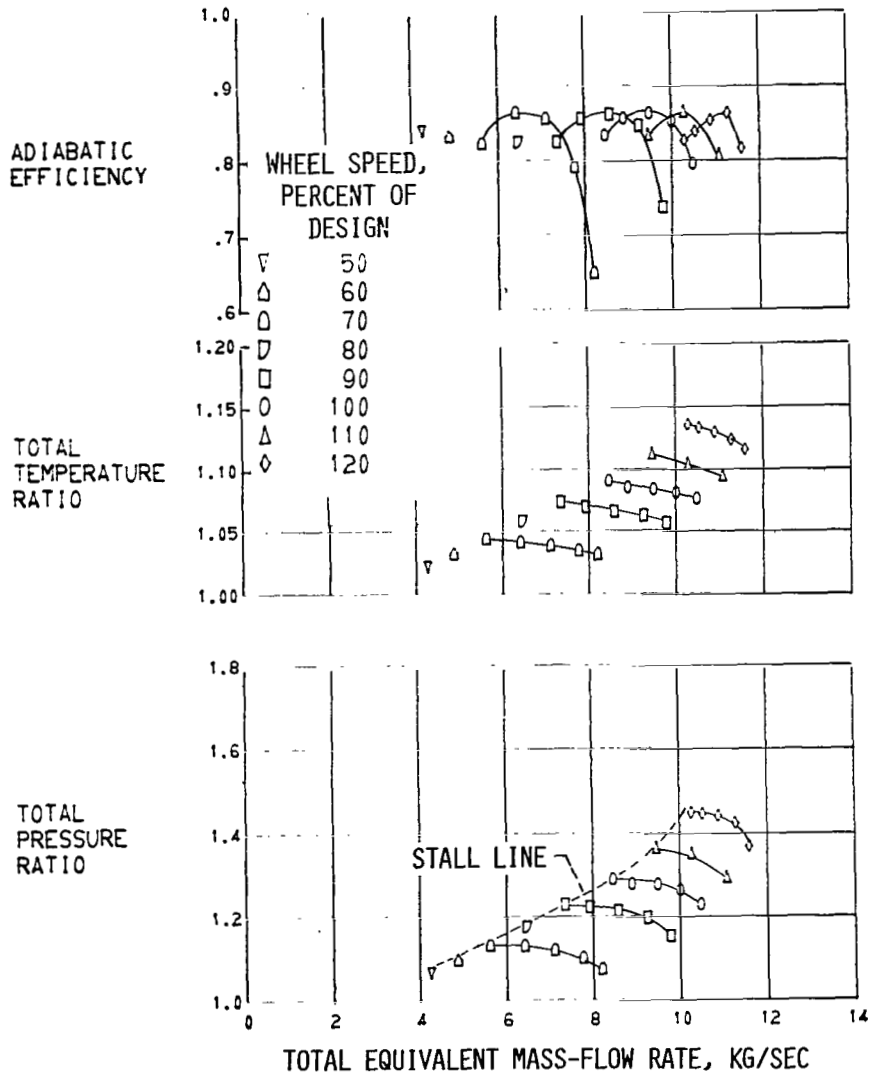

Figure 36. - Overall performance of stage 26B-21.

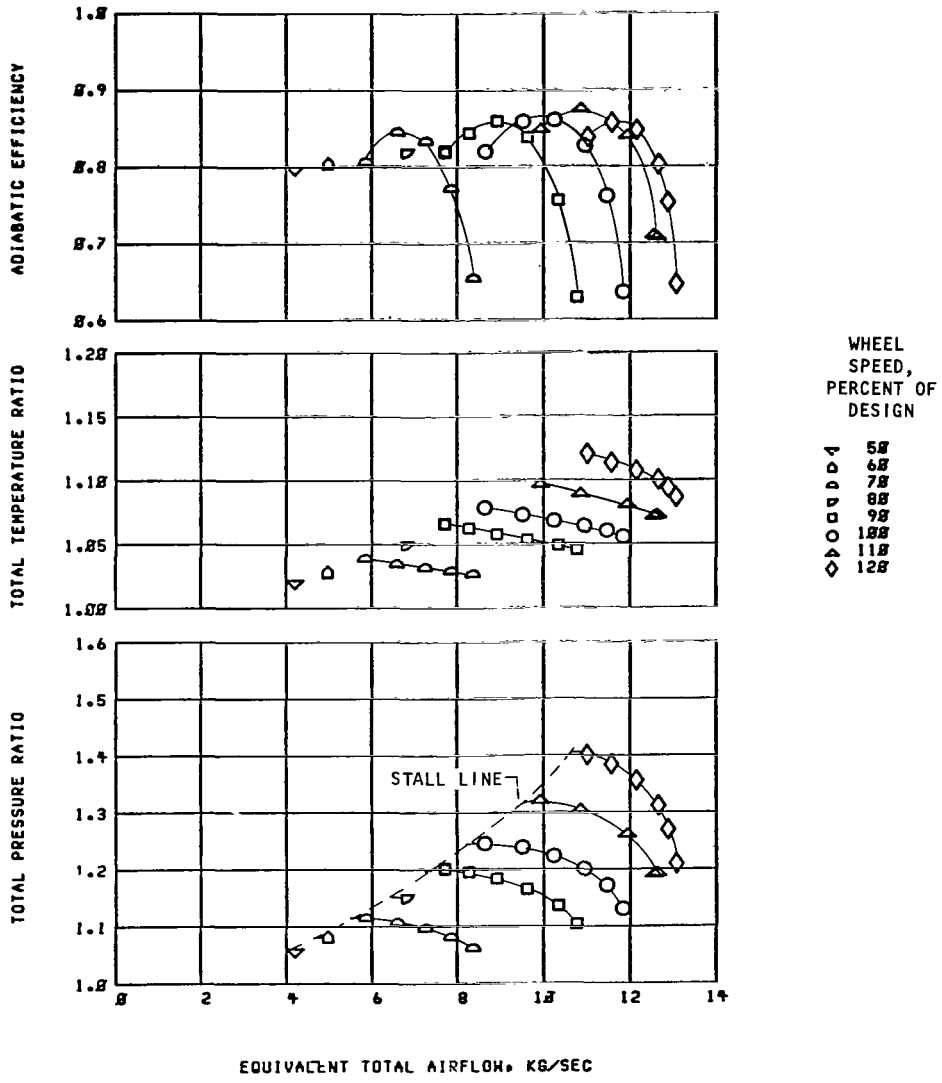

Figure 37. - Overall performance of stage 26D-21.

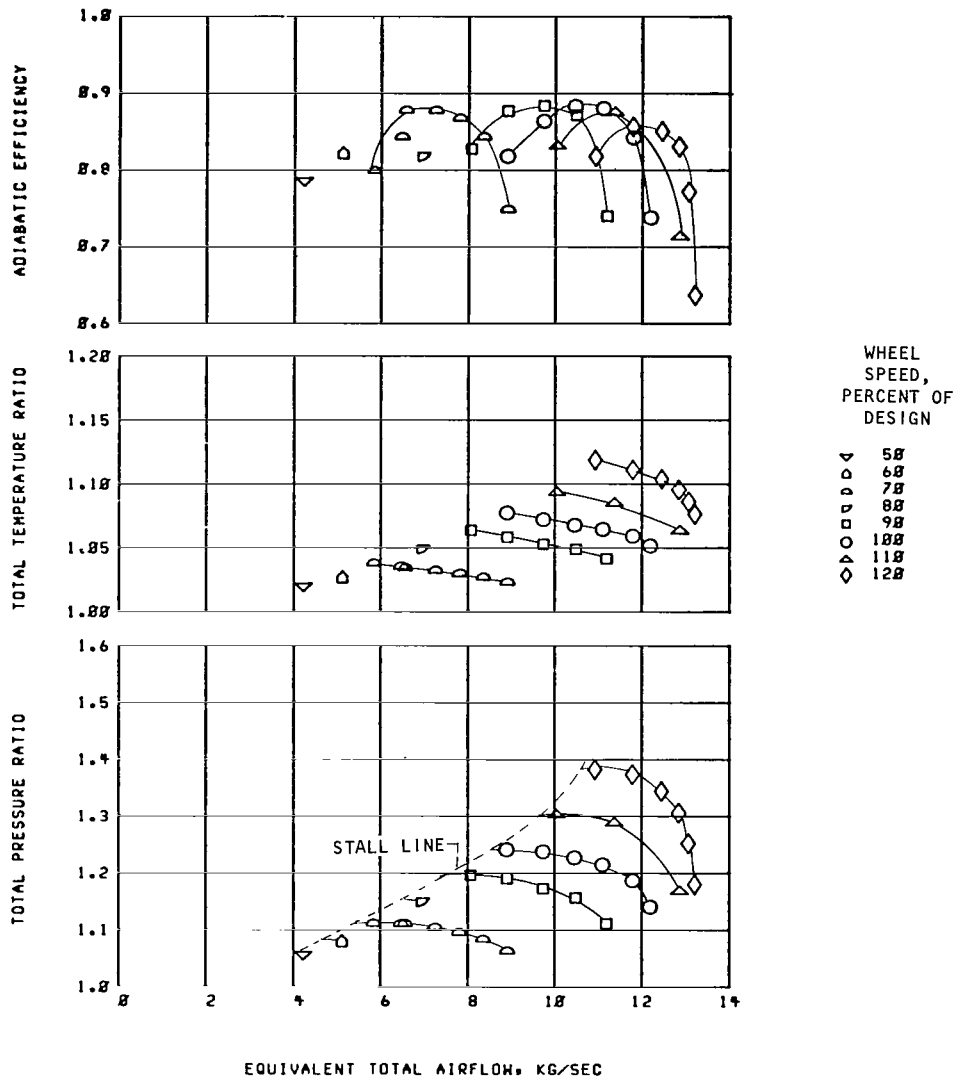

Figure 38. - Overall performance of stage 26D-21D.

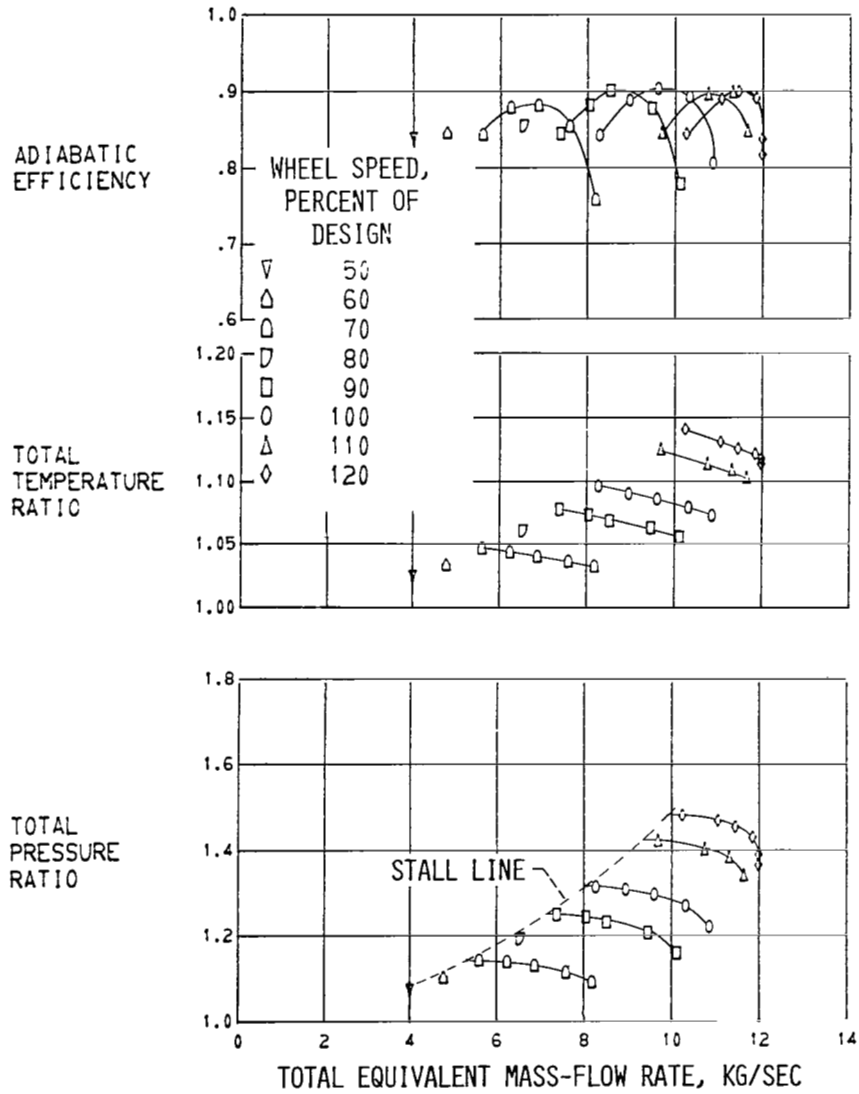

Figure 39. - Overall performance of stage 27A-21.

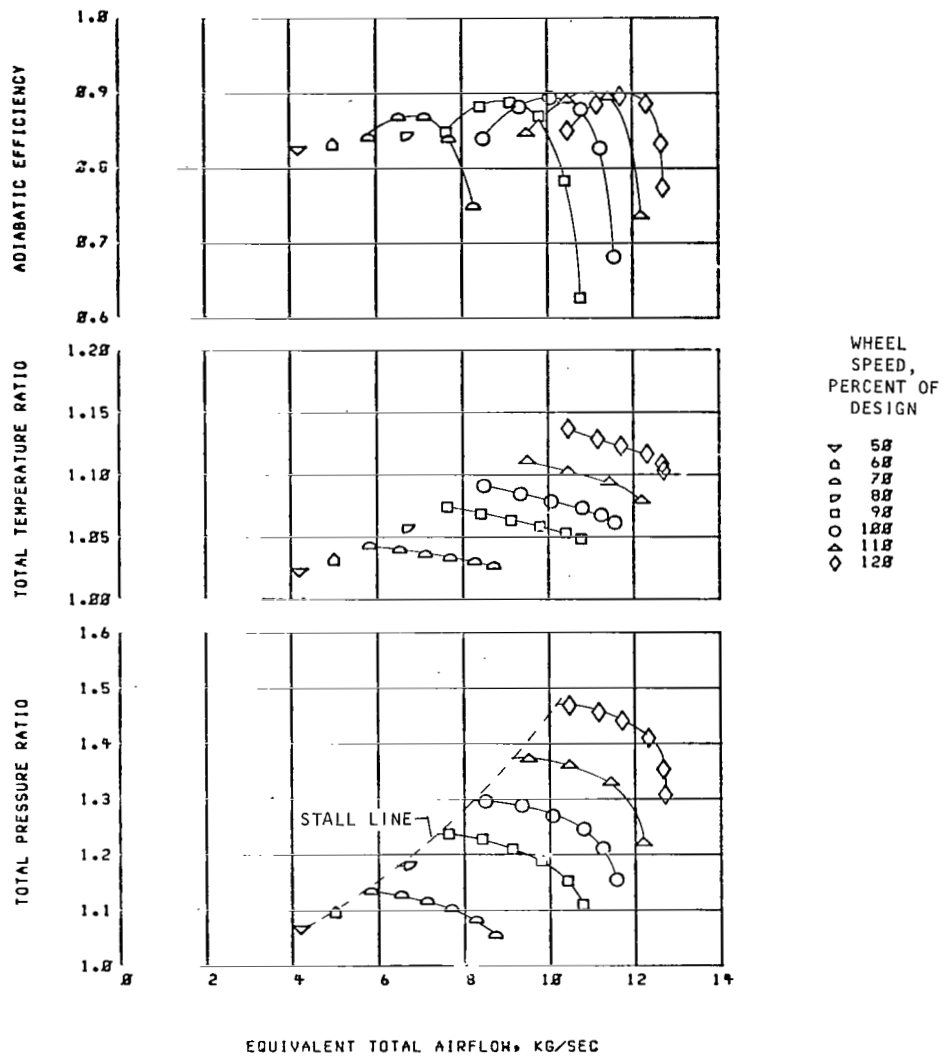

Figure 40. - Overall performance of stage 27C-21.

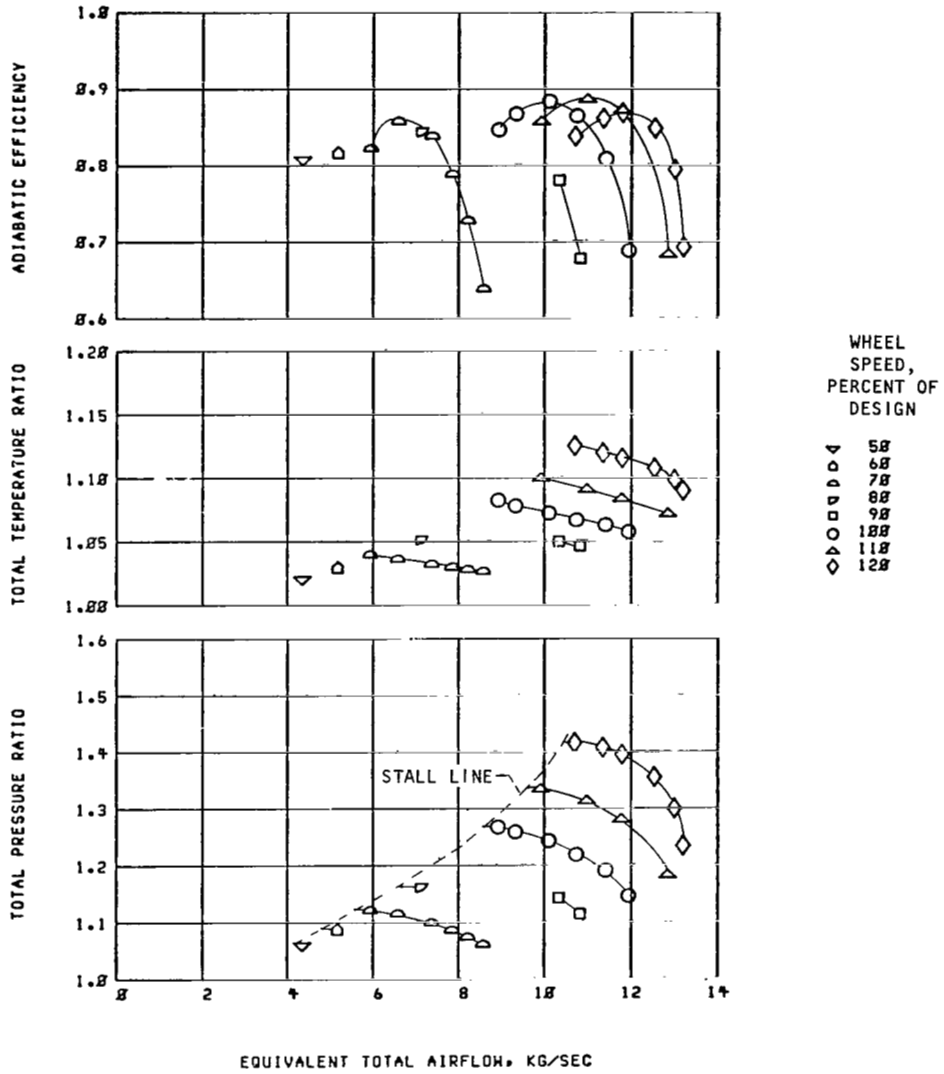

Figure 41. - Overall performance of stage 27D-21.

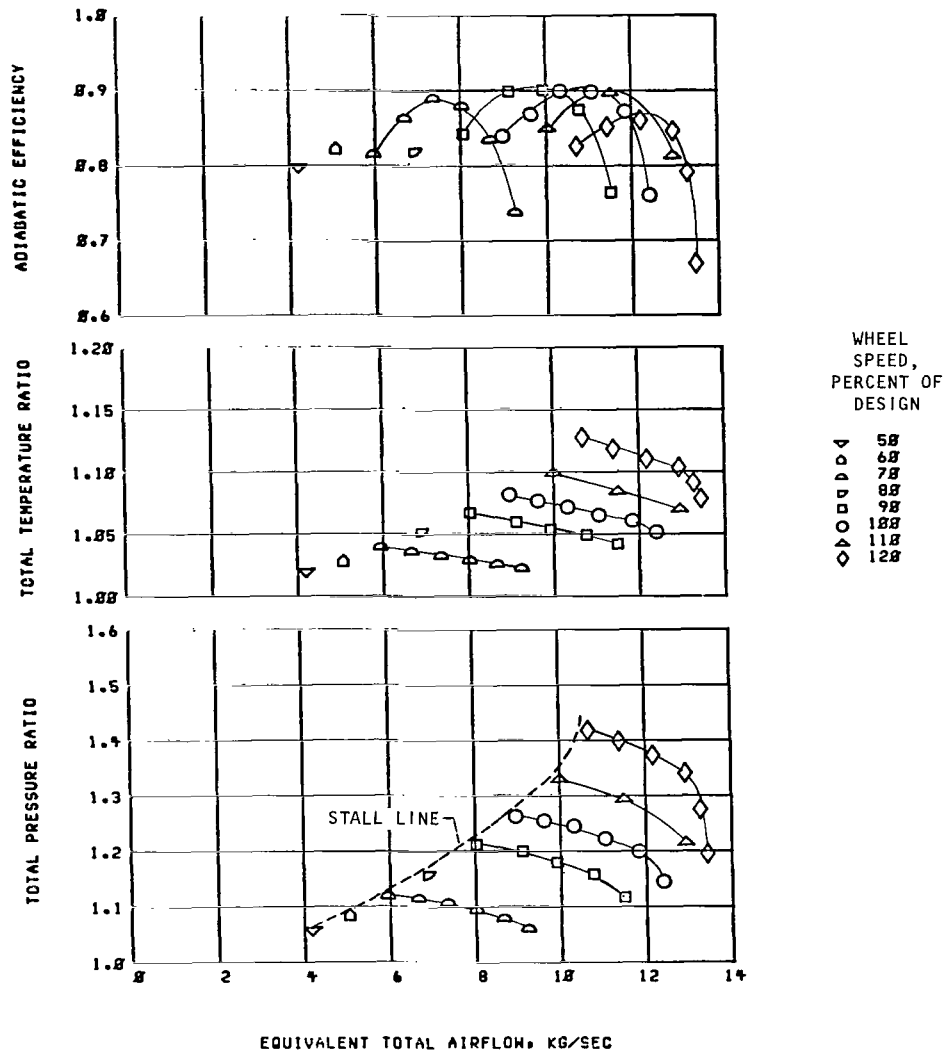

Figure 42. - Overall performance of stage 27D-21D.

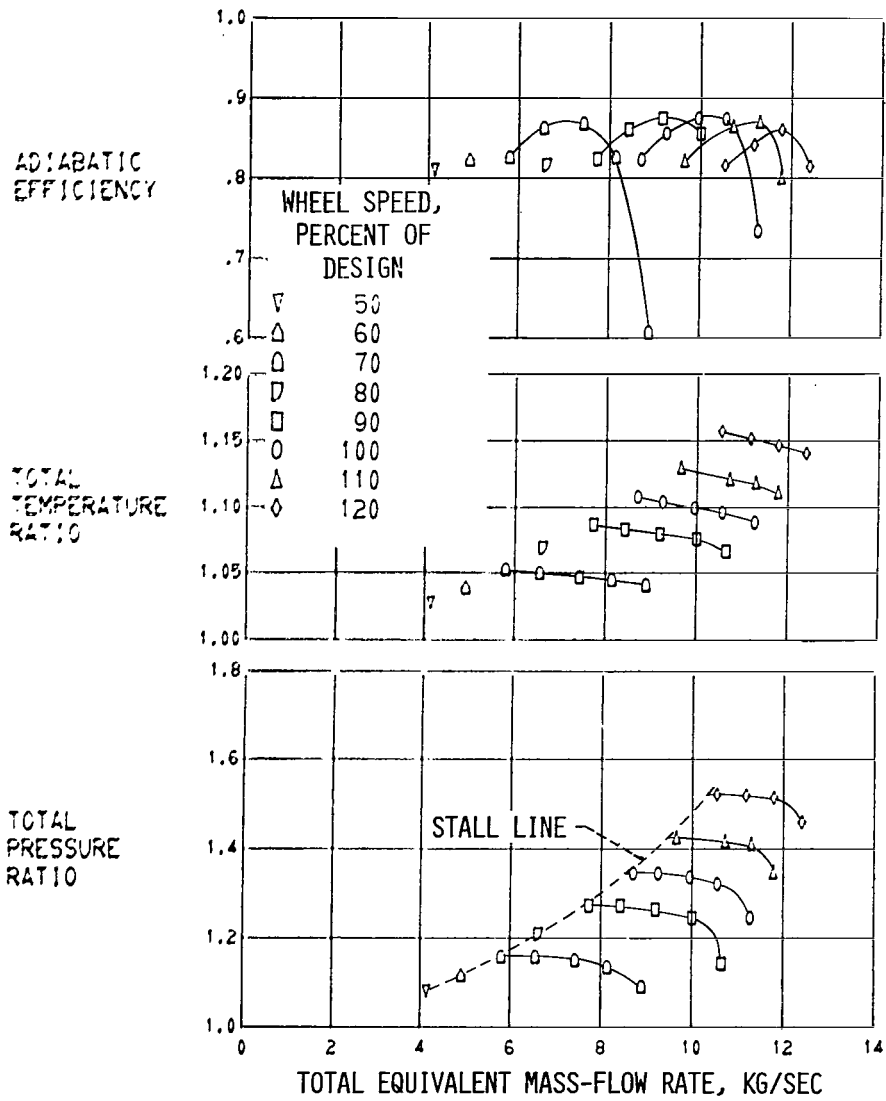

Figure 43. - Overall performance of stage 28B-22.

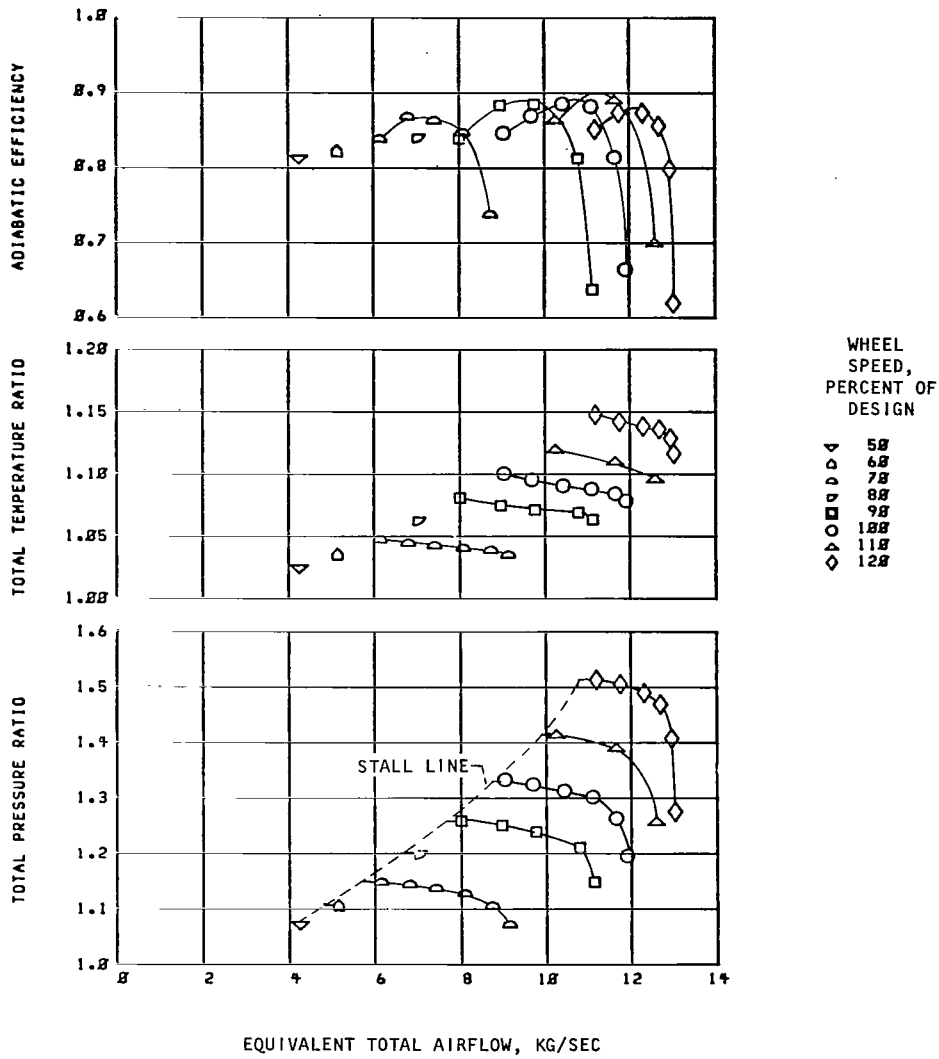

Figure 44. - Overall performance of stage 28D-22.

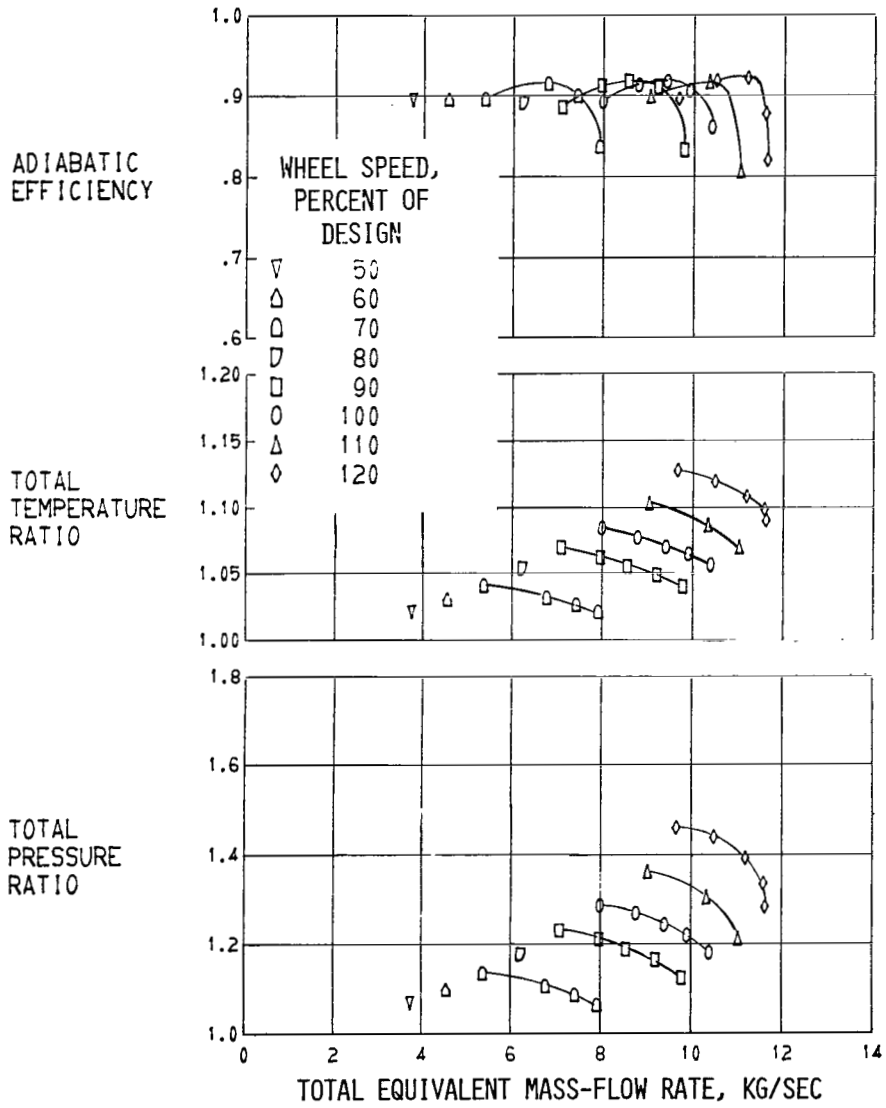

Figure 45. - Overall performance of rotor 23B.

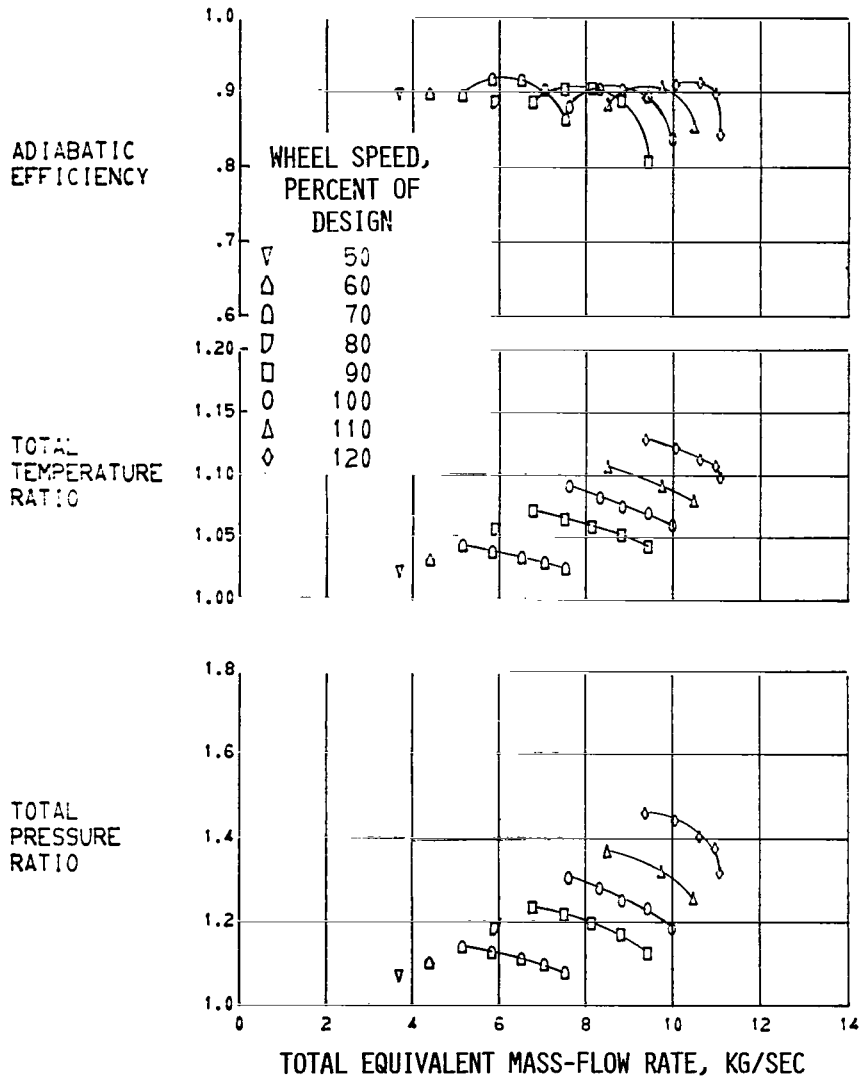

Figure 46. - Overall performance of rotor 23D.

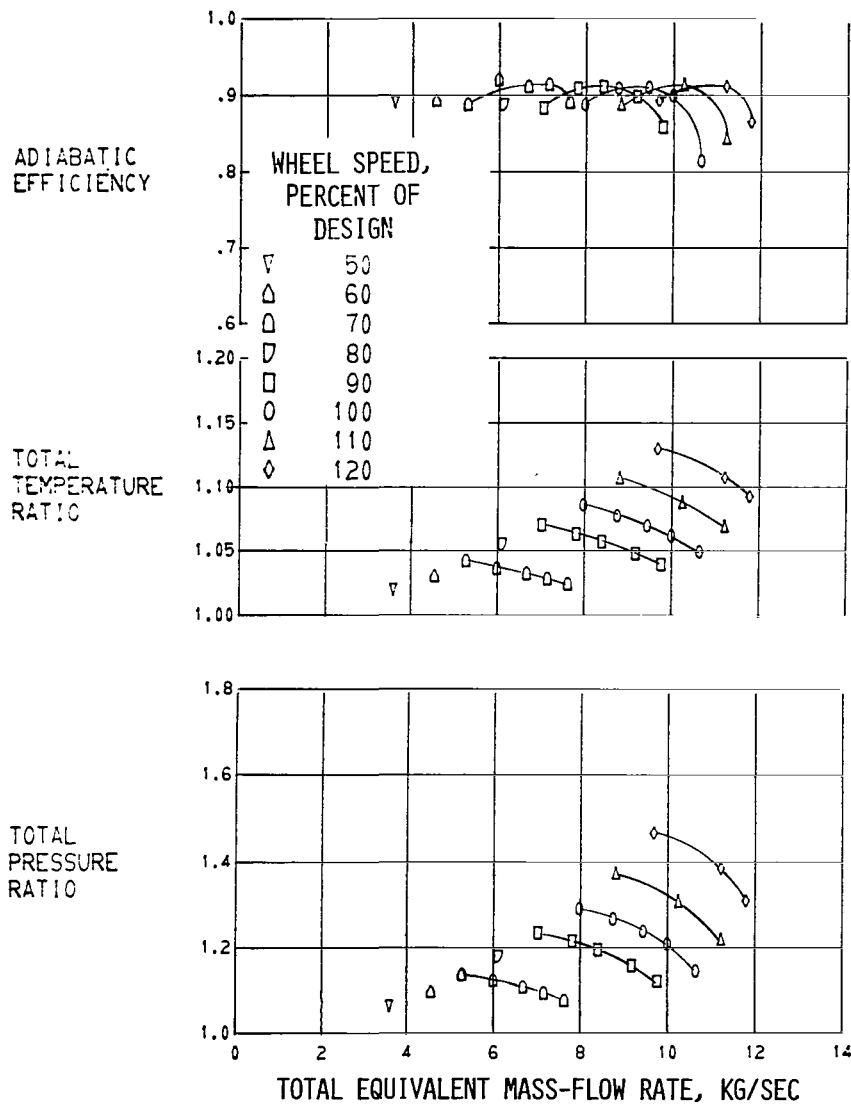

Figure 47. - Overall performance of rotor 24A.

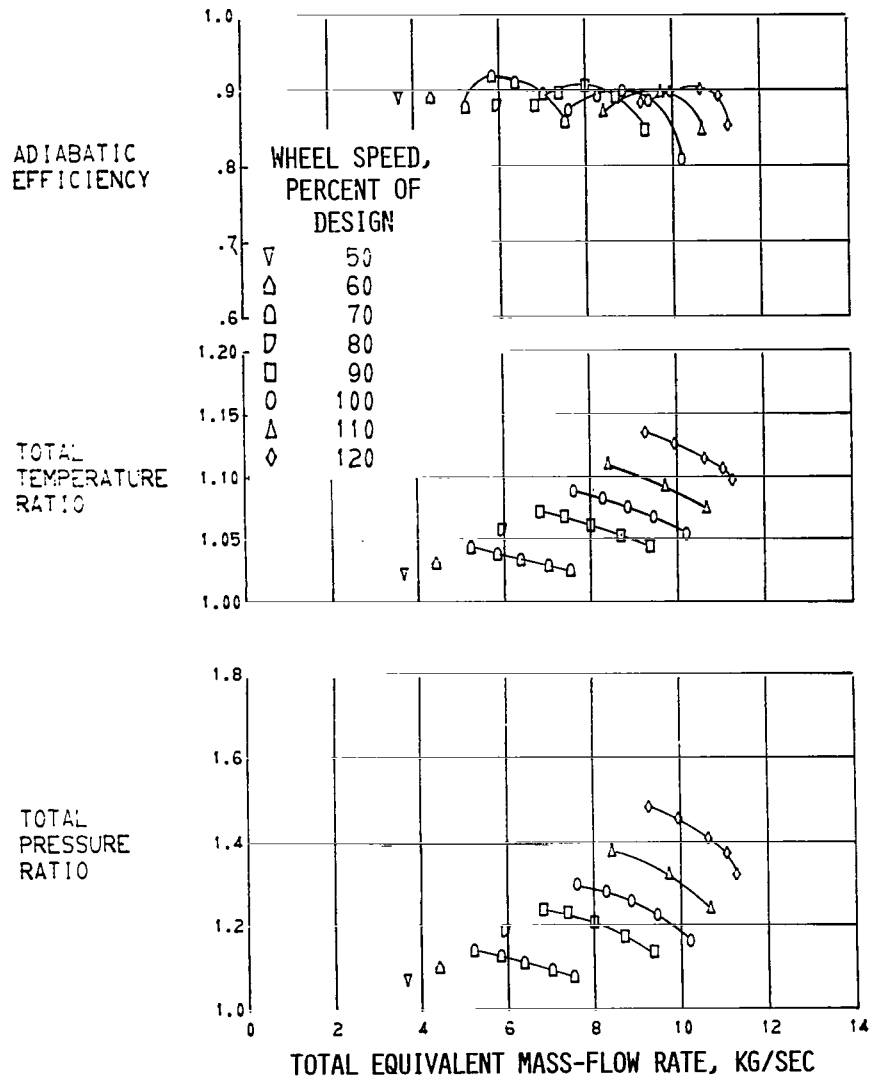

Figure 48. - Overall performance of rotor 24B.

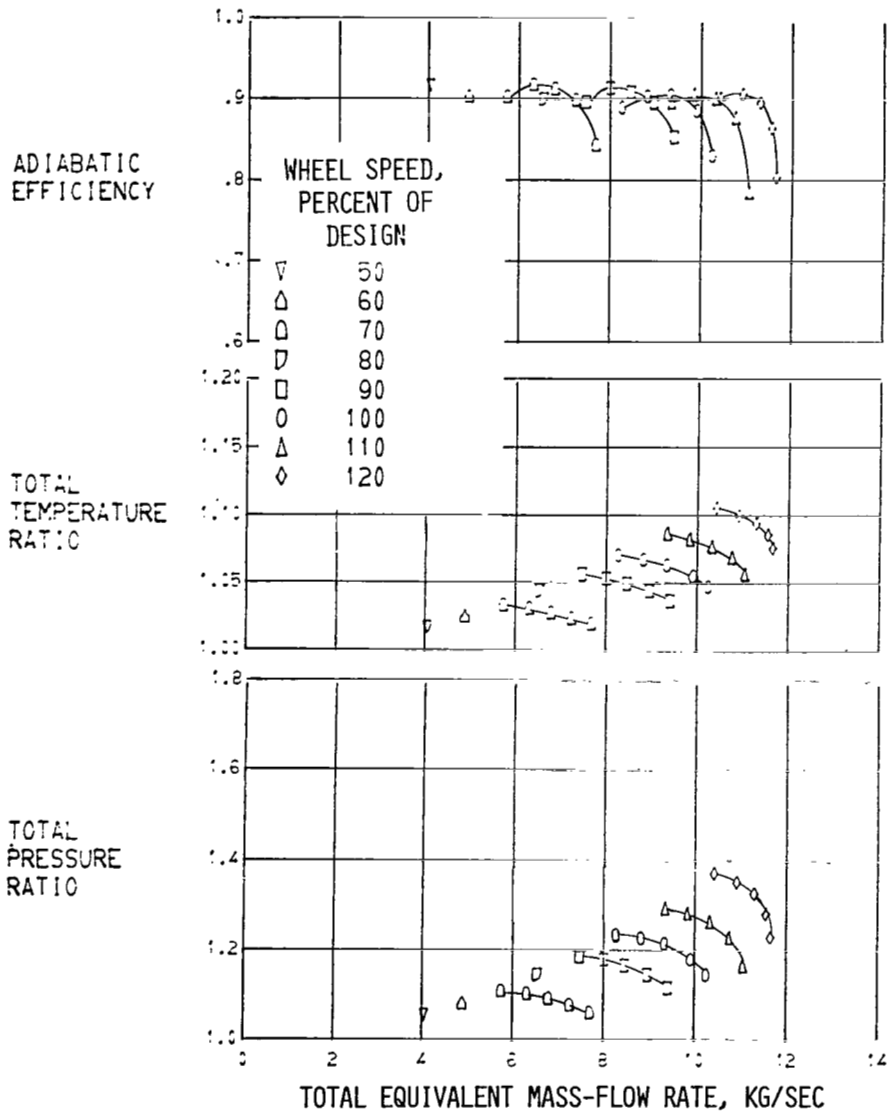

Figure 49. - Overall performance of rotor 25A.

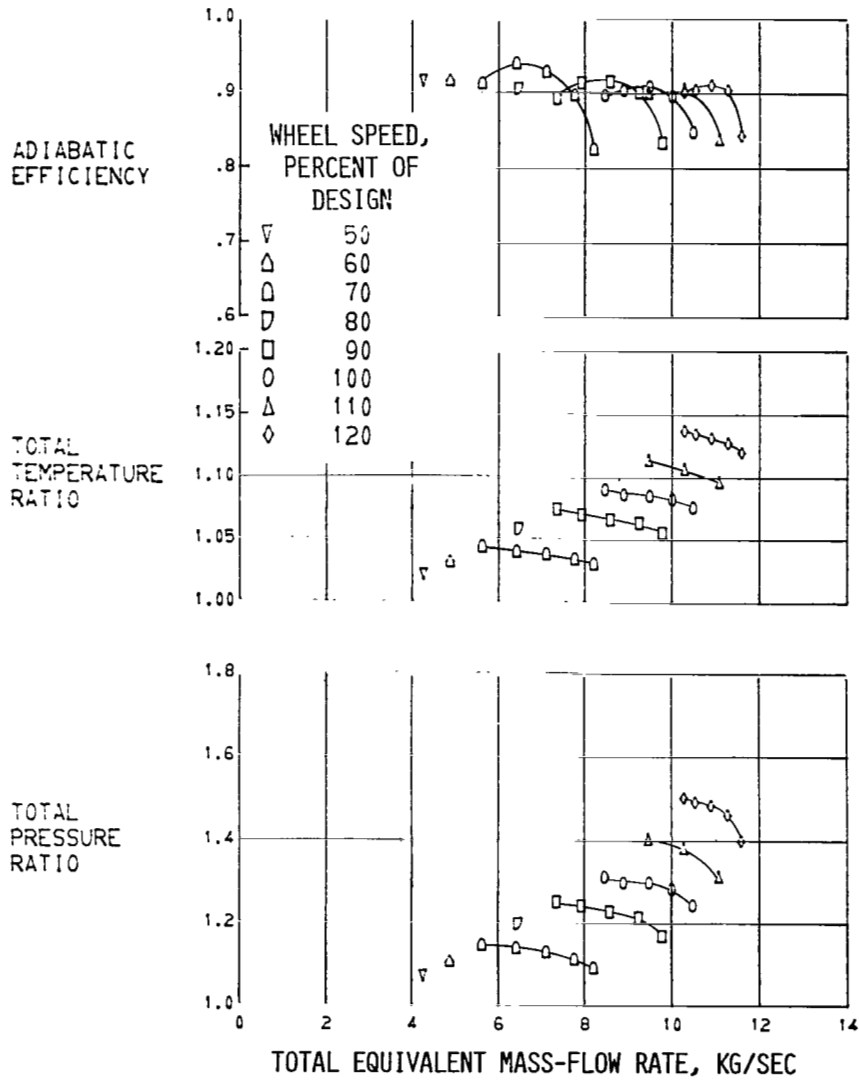

Figure 50. - Overall performance of rotor 26B.

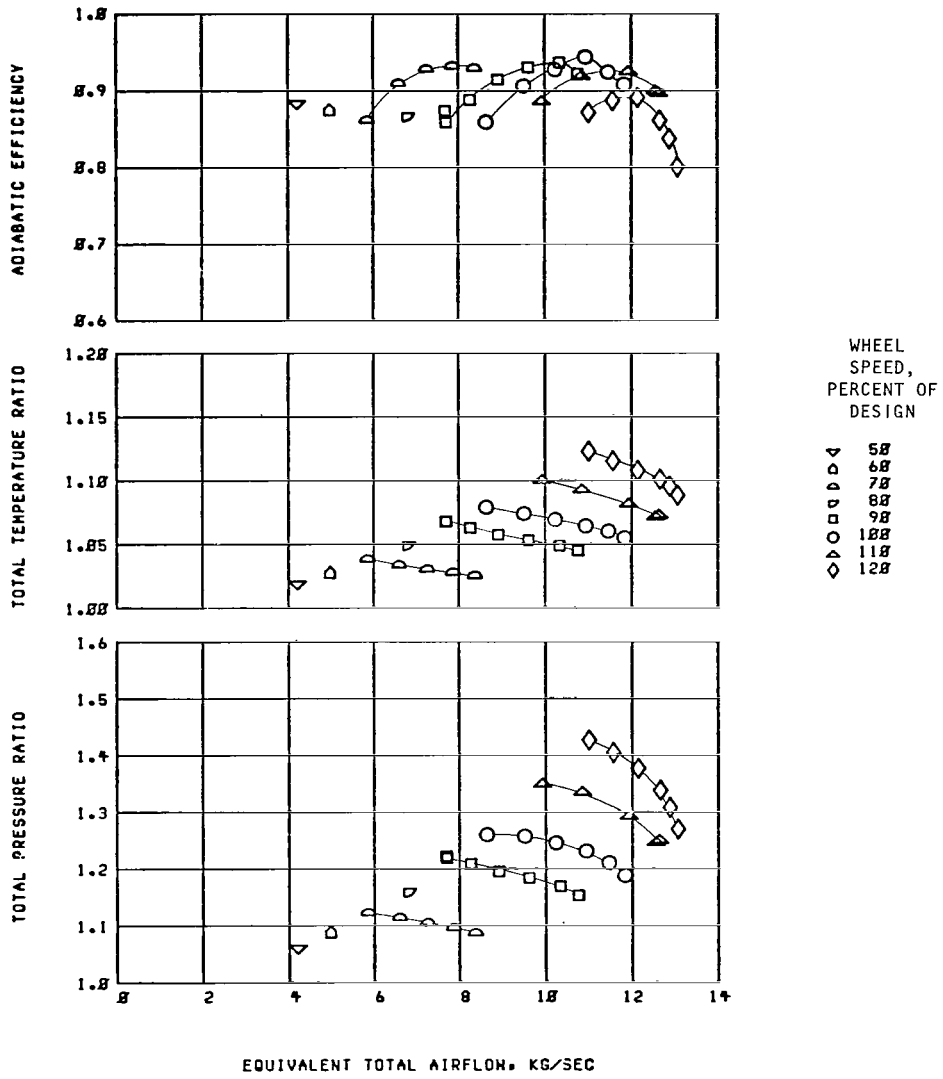

Figure 51. - Overall performance of rotor 26D in stage 26D-21.

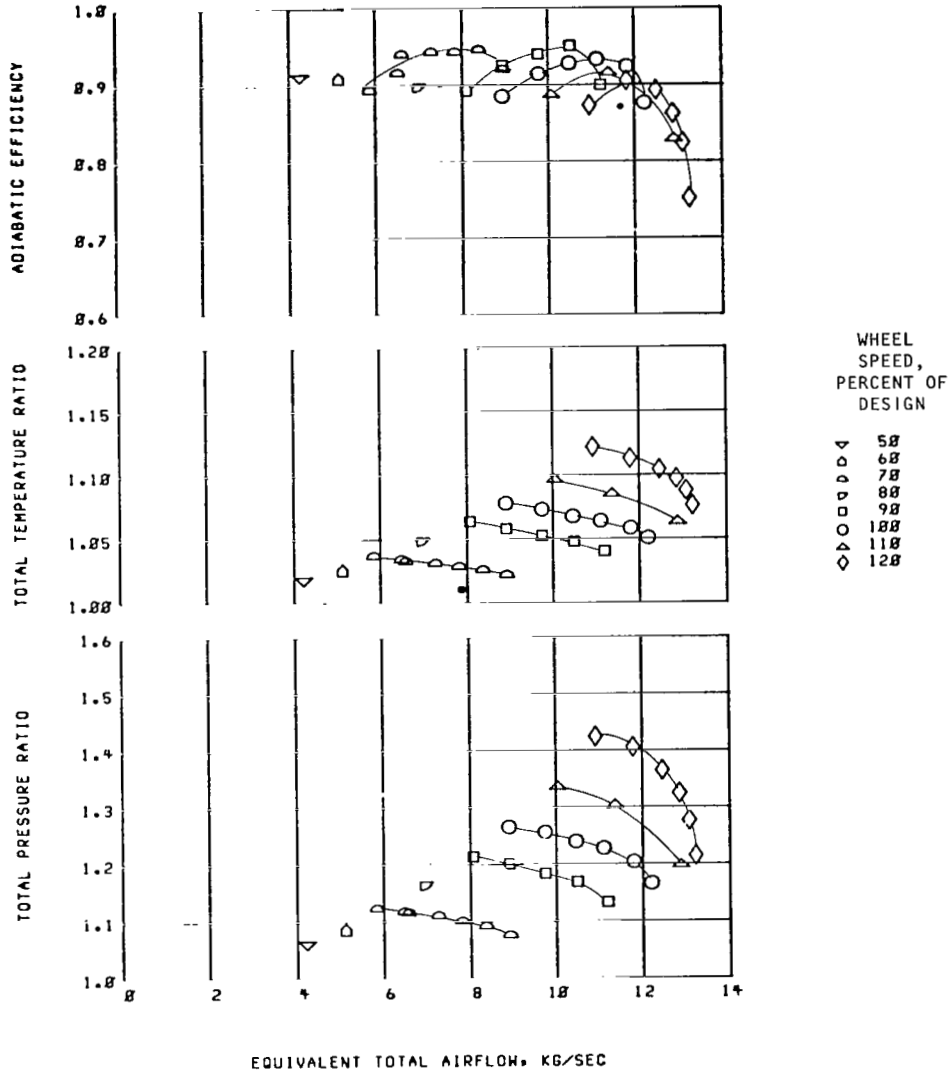

Figure 52. - Overall performance of rotor 26D in stage 26D-21D.

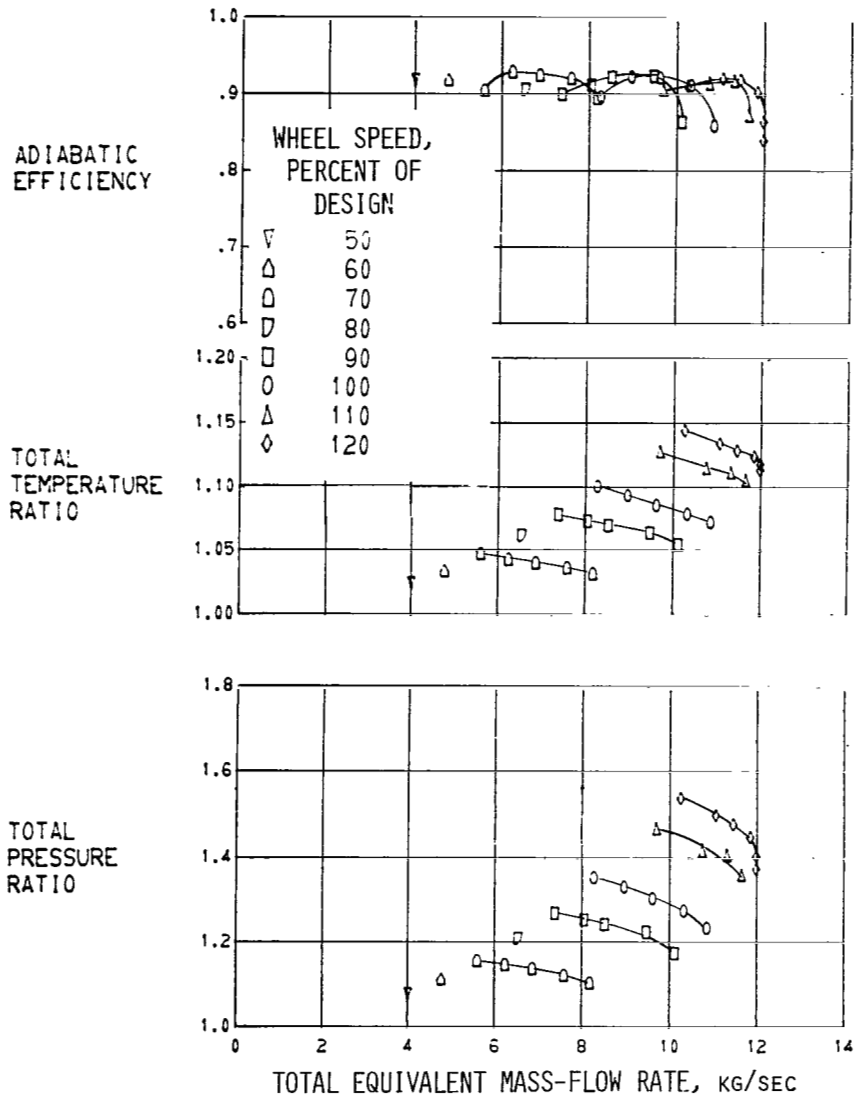

Figure 53. - Overall performance of rotor 27A.

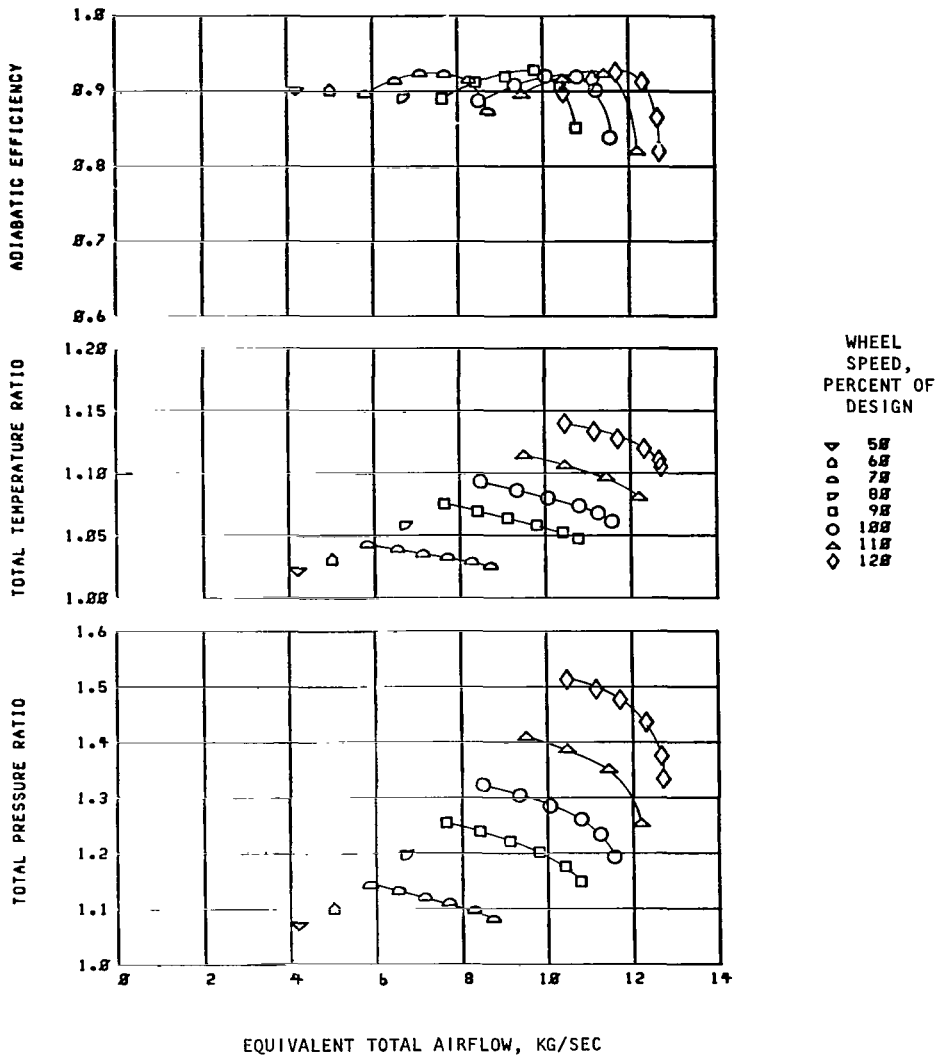

Figure 54. - Overall performance of rotor 27C.

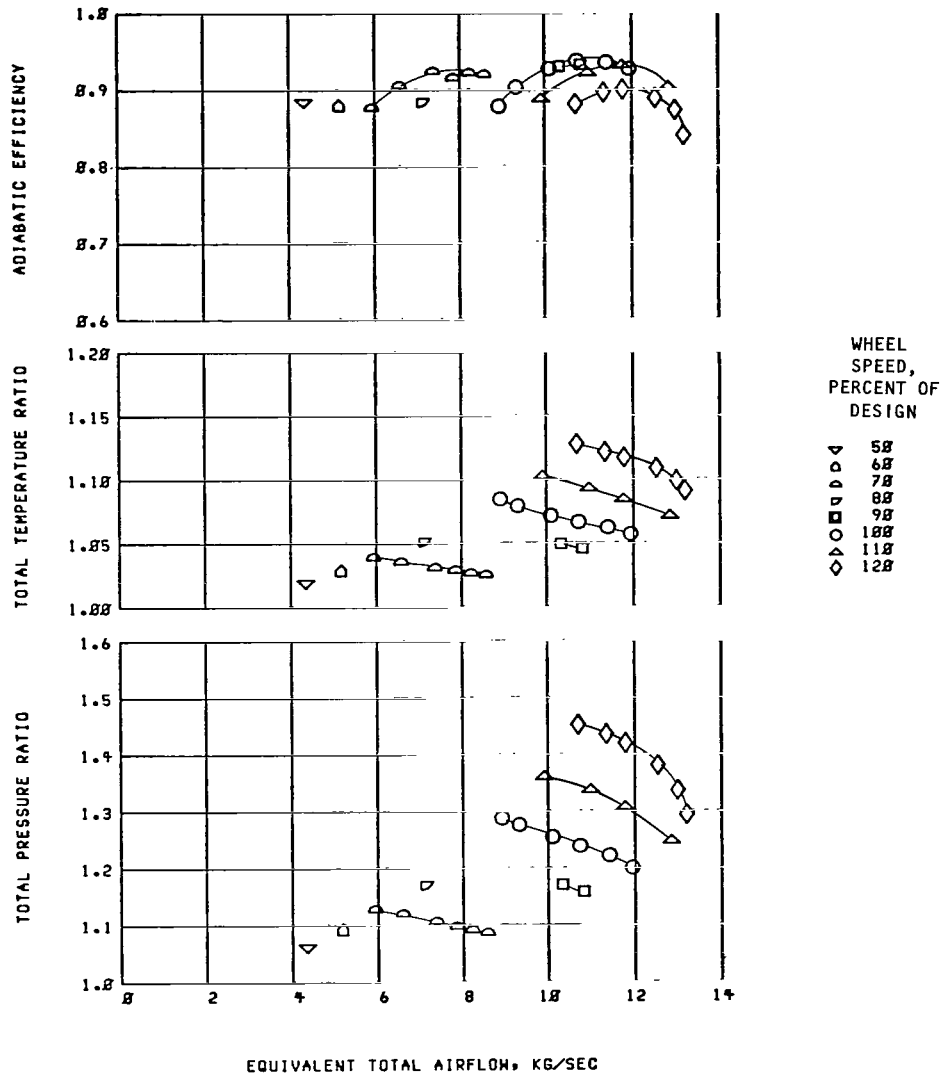

Figure 55. - Overall performance of rotor 27D in stage 27D-21.

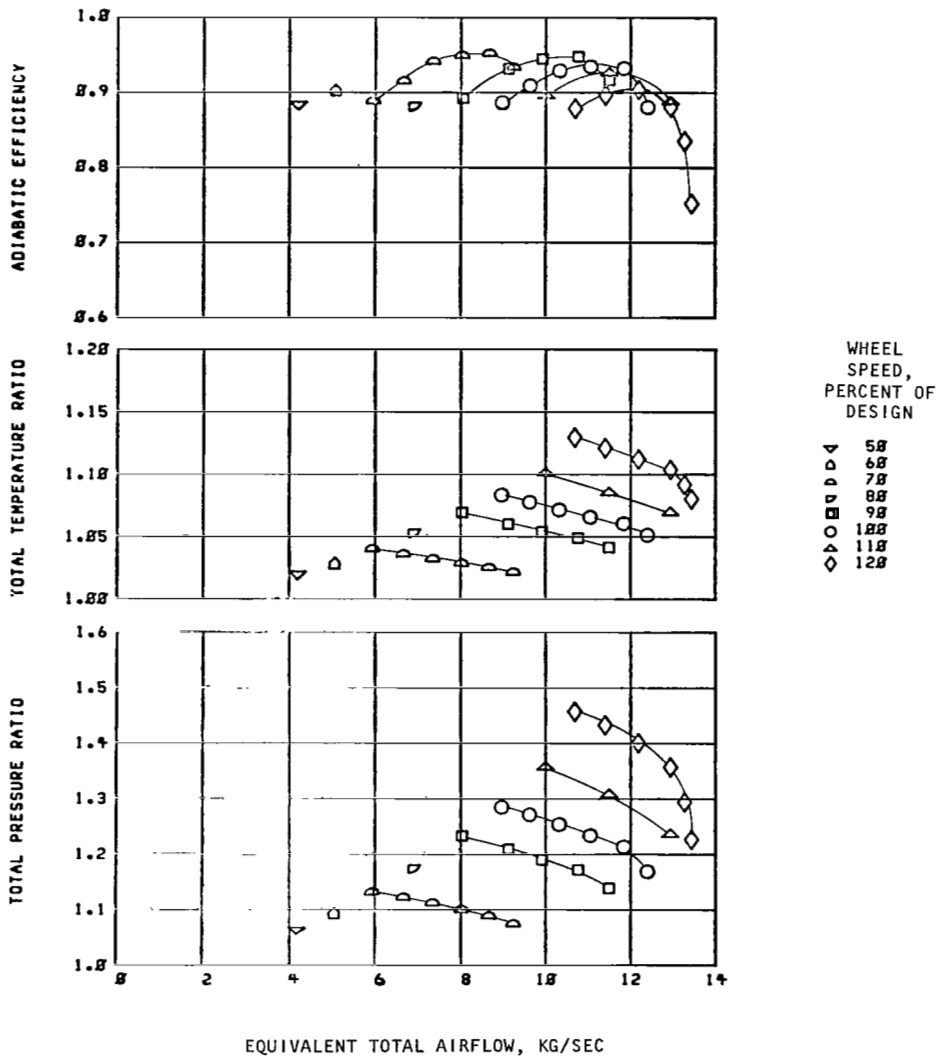

Figure 56. - Overall performance of rotor 27D in stage 27D-21D.

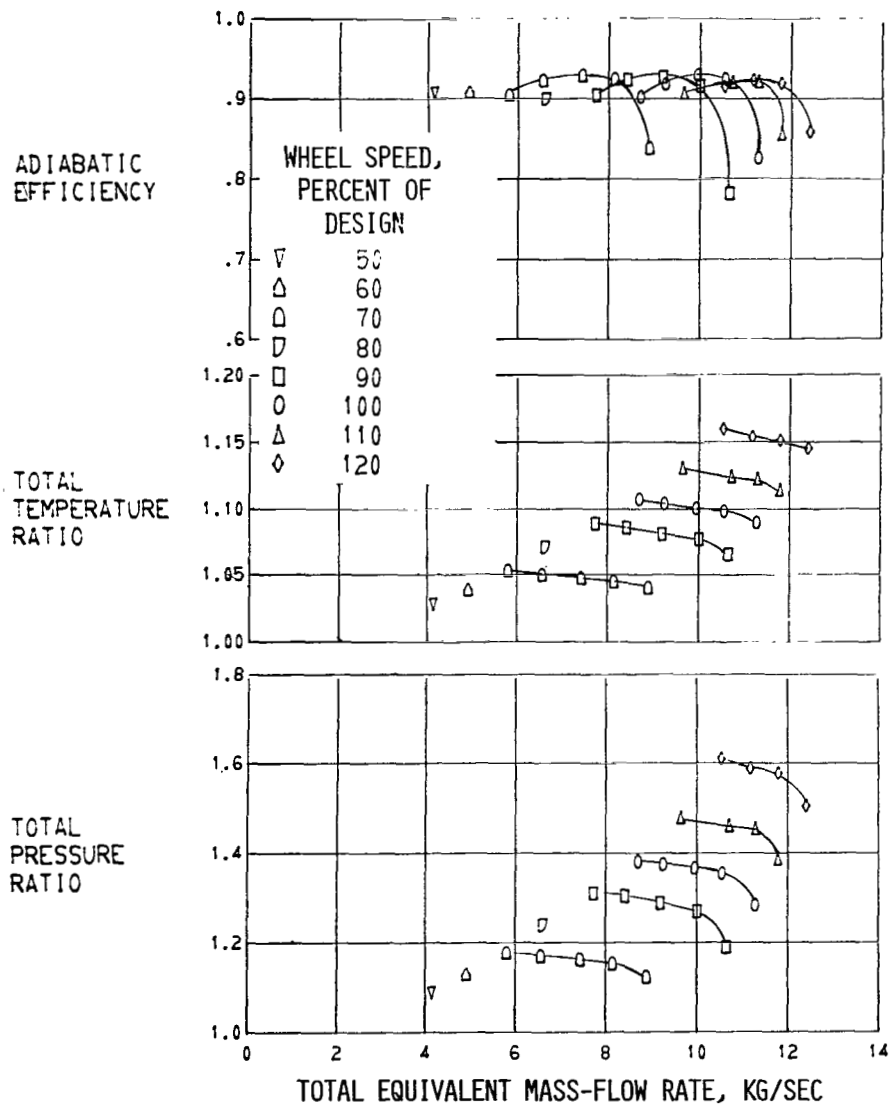

Figure 57. - Overall performance of rotor 28B.

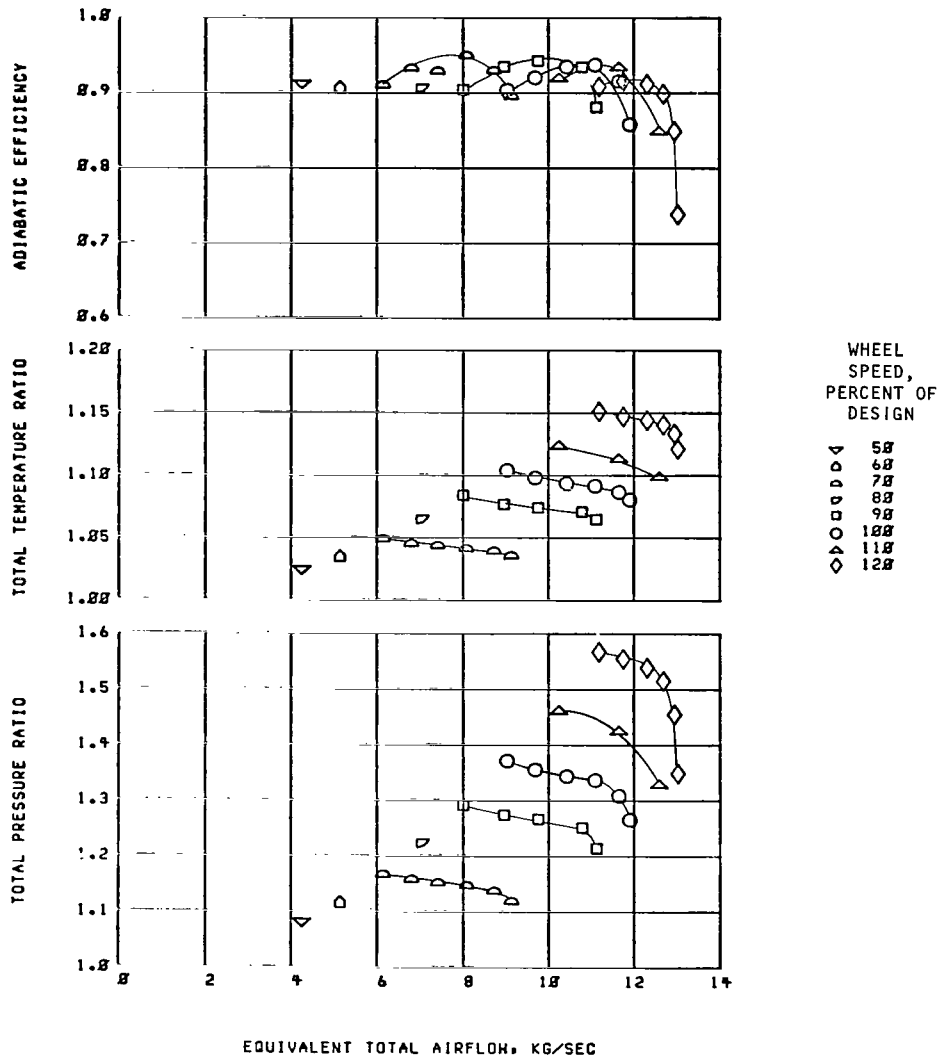

Figure 58. - Overall performance of rotor 28D.

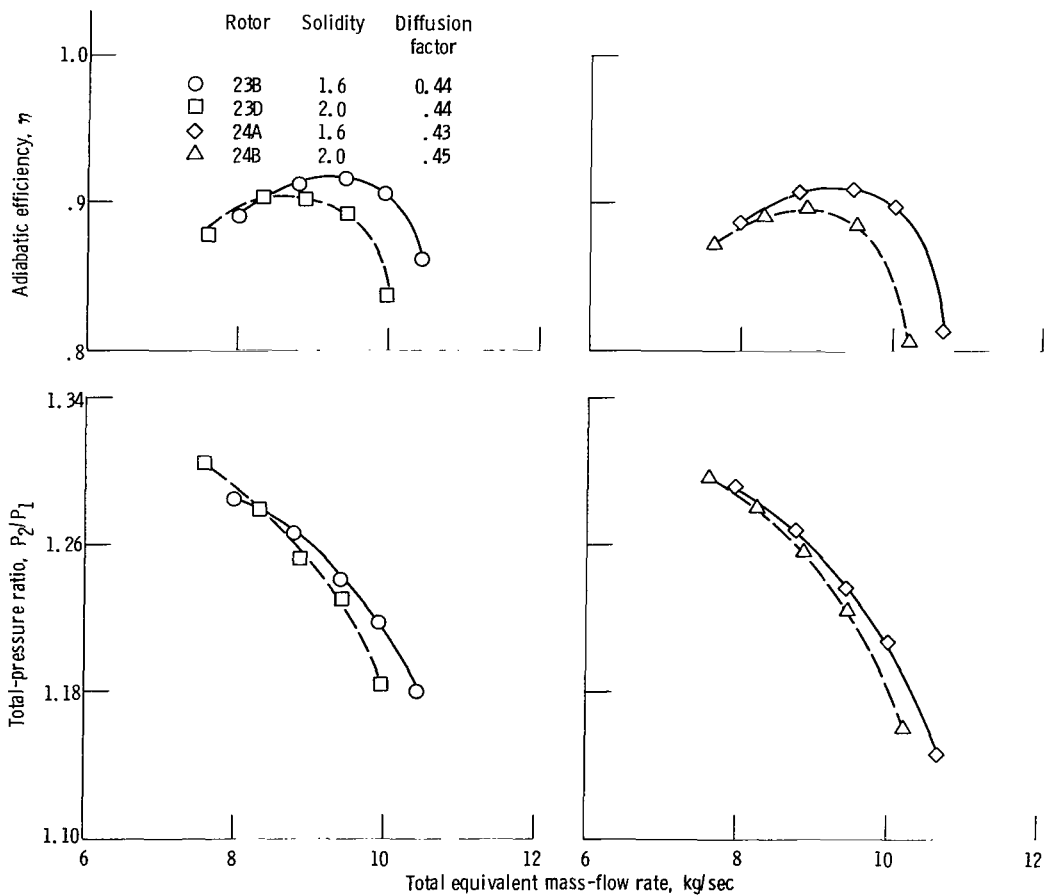
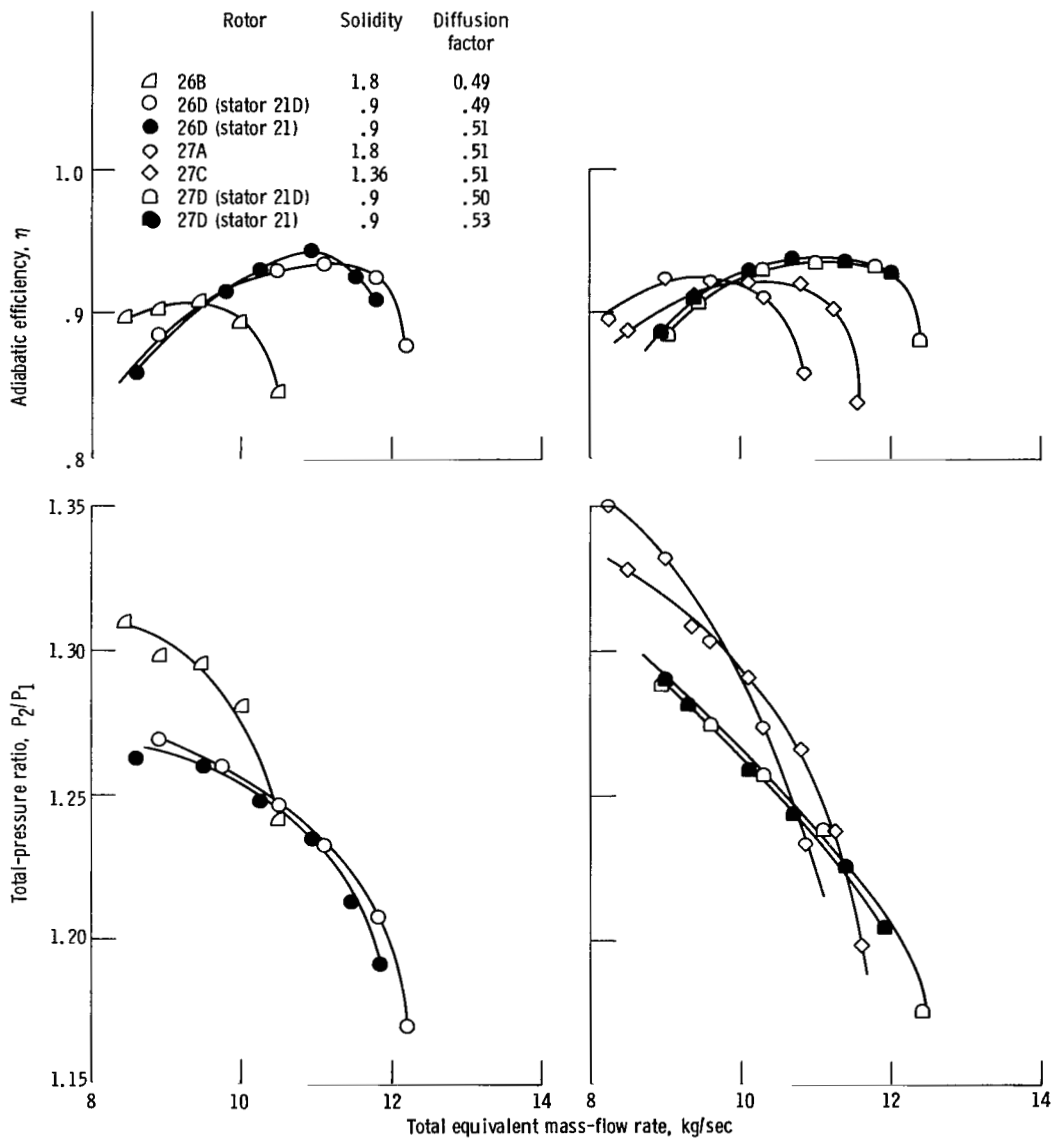

Figure 59. - Effect of solidity on rotor performance at constant aspect ratio for rotors 23B, 23D, 24A, and 24B. Wheel speed, 100 percent of design.



(a) Rotor aspect ratio, 1.2.

(b) Rotor aspect ratio, 0.7.

Figure 60. - Effect of solidity on rotor performance at constant aspect ratio for rotors 26B, 26D, and 27D. Wheel speed, 100 percent of design.

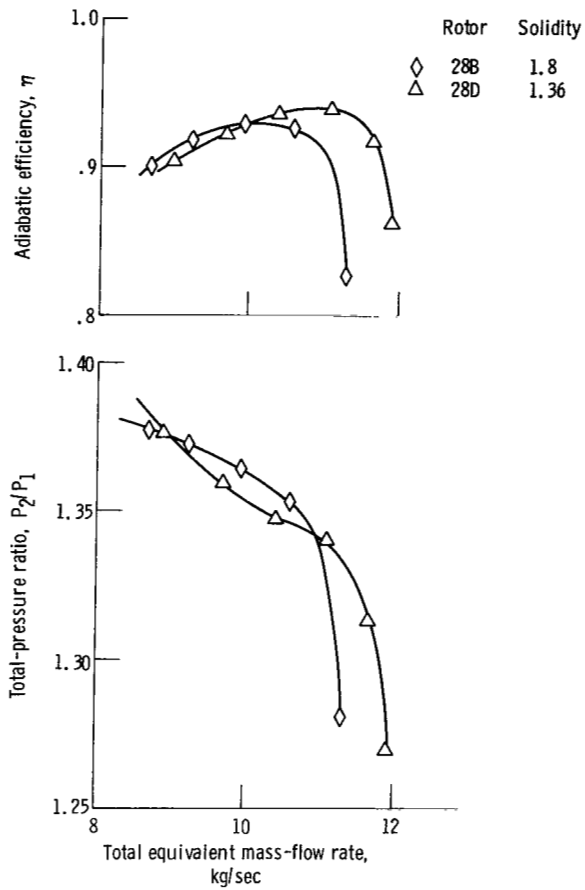

Figure 61. - Effect of solidity on rotor performance at constant aspect ratios for rotors 28B and 28D. Wheel speed, 100 percent of design; rotor aspect ratio, 0.8; diffusion factor, 0.56.

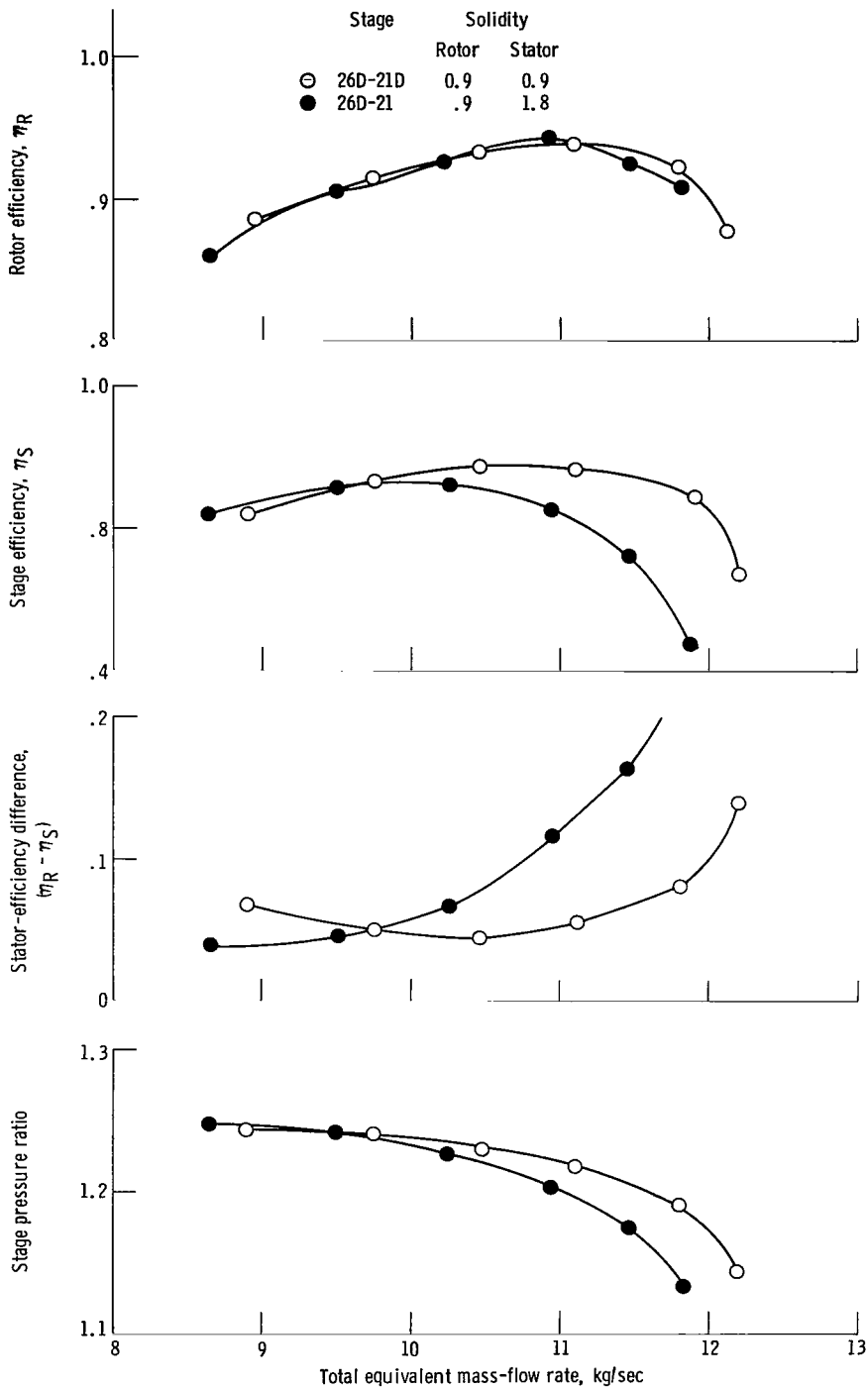

Figure 62. - Effect of stator solidity on design-speed performance for stages 26D-21 and 26D-21D. Rotor aspect ratio, 1.2.

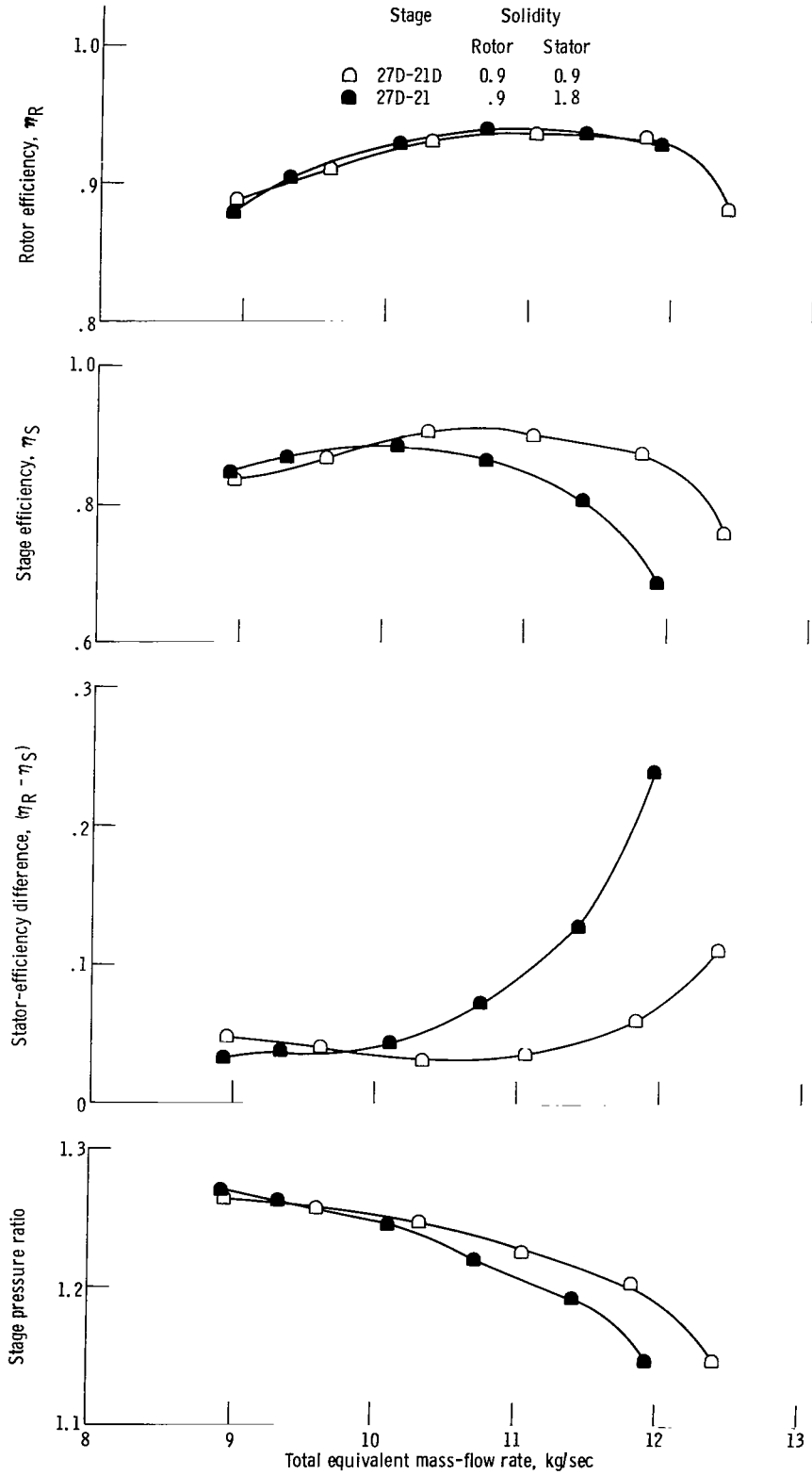
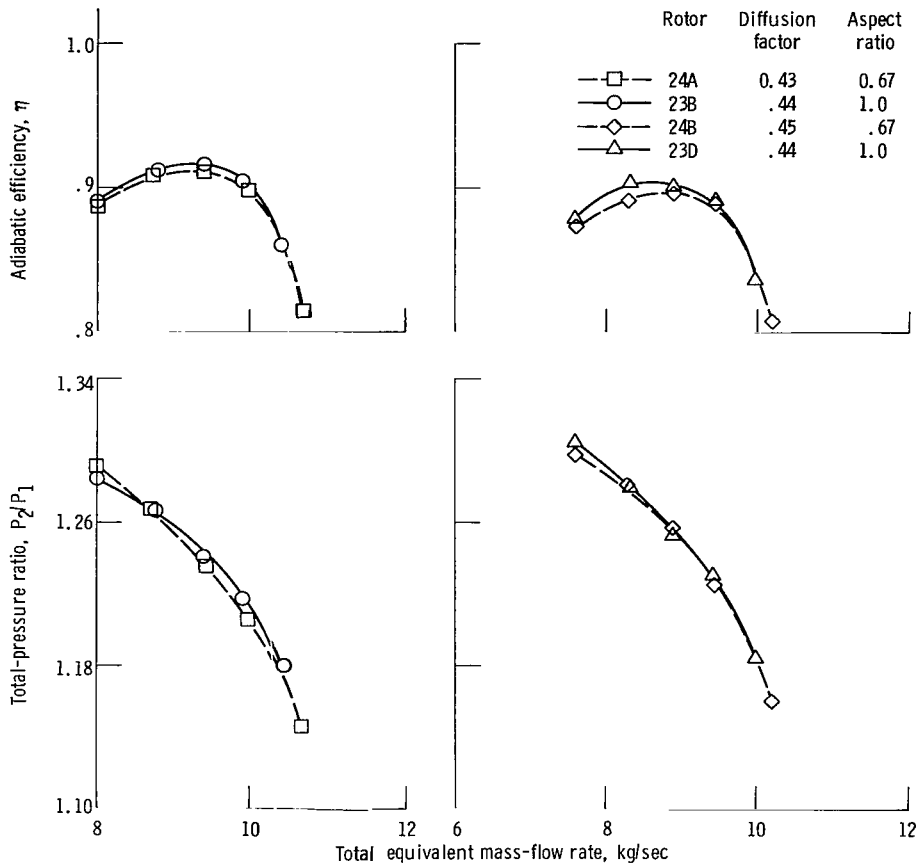

Figure 63. - Effect of stator solidity on design-speed performance for stages 27D-21 and 27D-21D. Rotor aspect ratio, 0.7.



(a) Rotor solidity, 1.6.

(b) Rotor solidity, 2.0.

Figure 64. - Effect of aspect ratio on rotor performance at constant solidity for stators 24A, 23B, 24B, and 23D. Wheel speed, 100 percent of design.

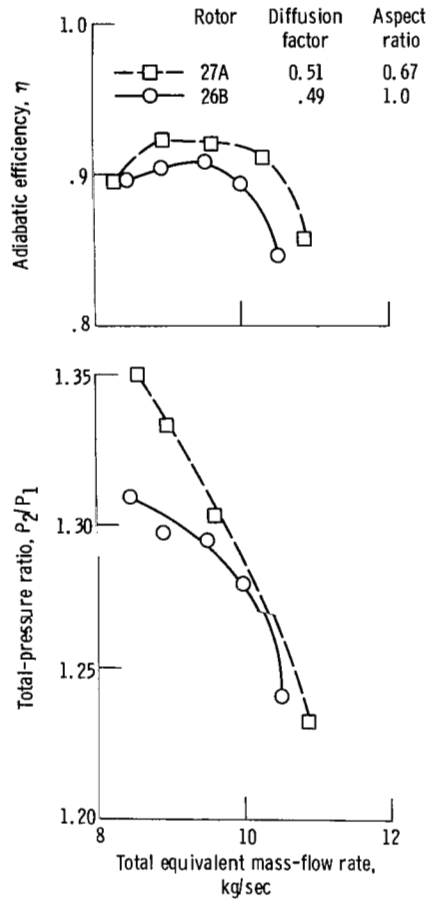

Figure 65. - Effect of aspect ratio on rotor performance at constant solidity for rotors 27A and 26B. Wheel speed, 100 percent of design; rotor solidity, 1.8.

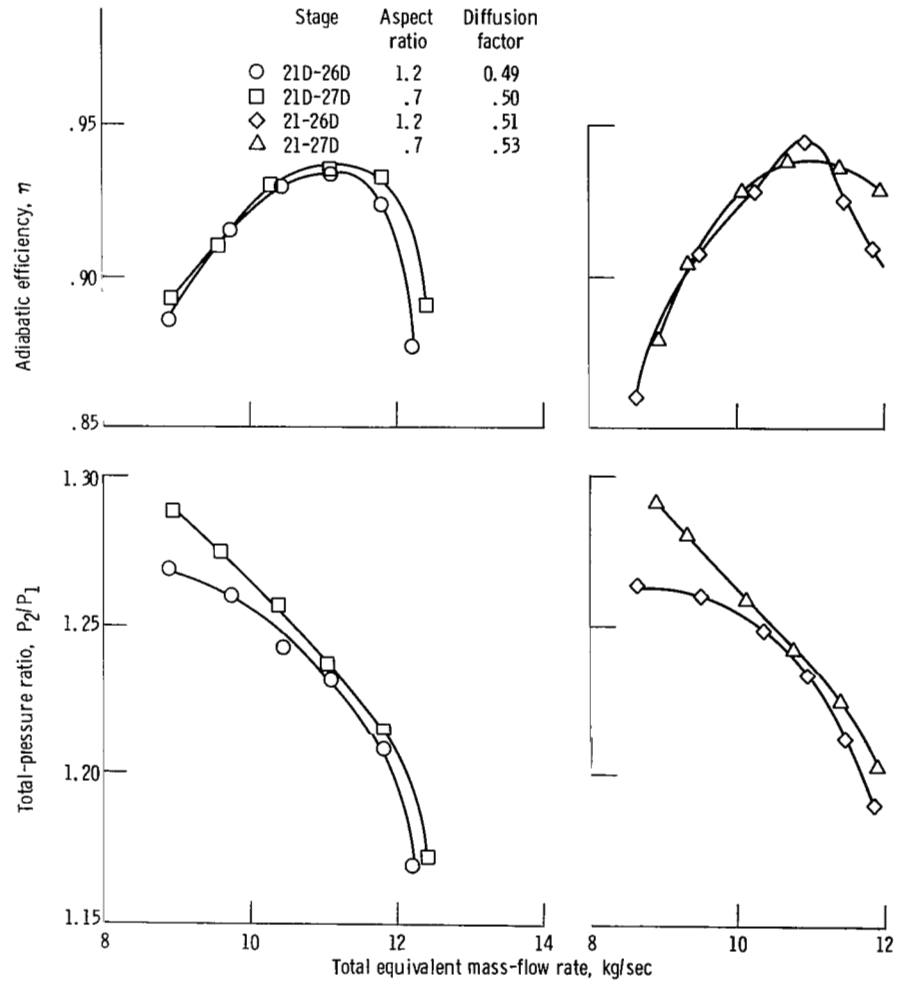
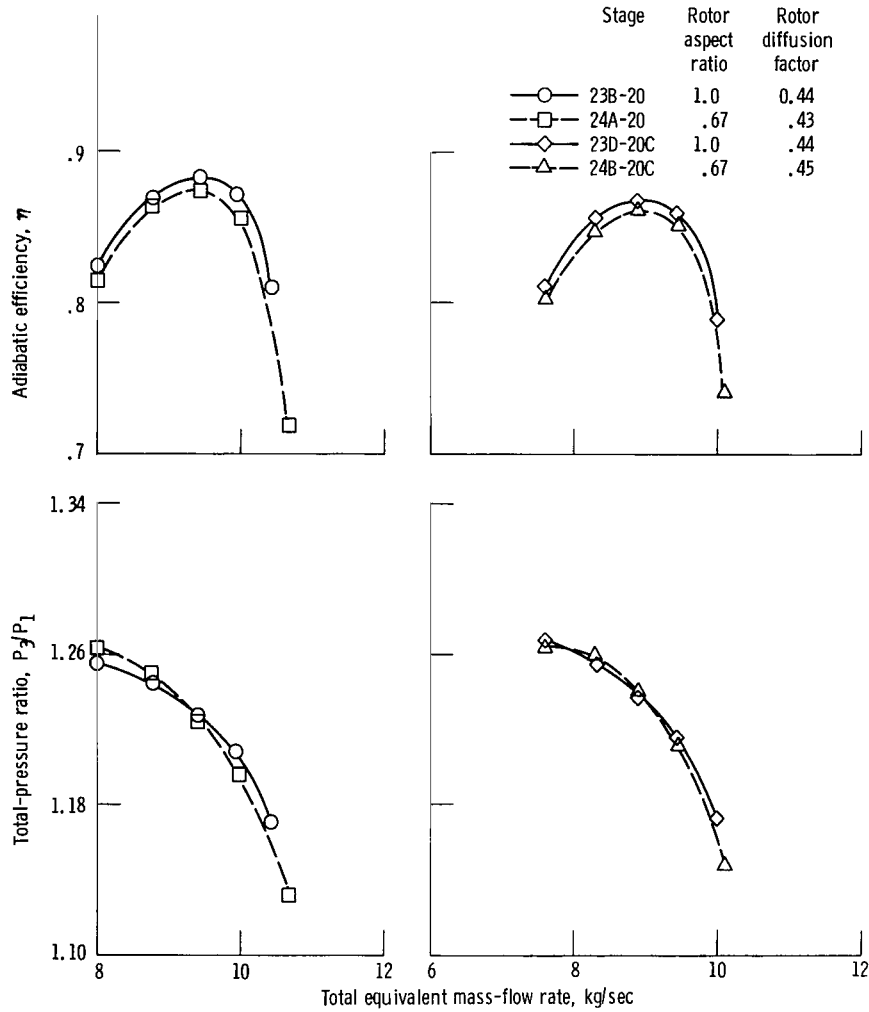

Figure 66. - Effect of aspect ratio on rotor performance at constant solidity for stages 21D-26D, 21D-27D, 21-26D, and 21-27D. Wheel speed, 100 percent of design; rotor solidity, 0.9.



(a) Rotor solidity, 1.6. (b) Rotor solidity, 2.0.
 Figure 67. - Effect of rotor aspect ratio on stage performance at constant solidity for stages 23B-20, 24A-20, 23D-20C, and 24B-20C. Wheel speed, 100 percent of design.

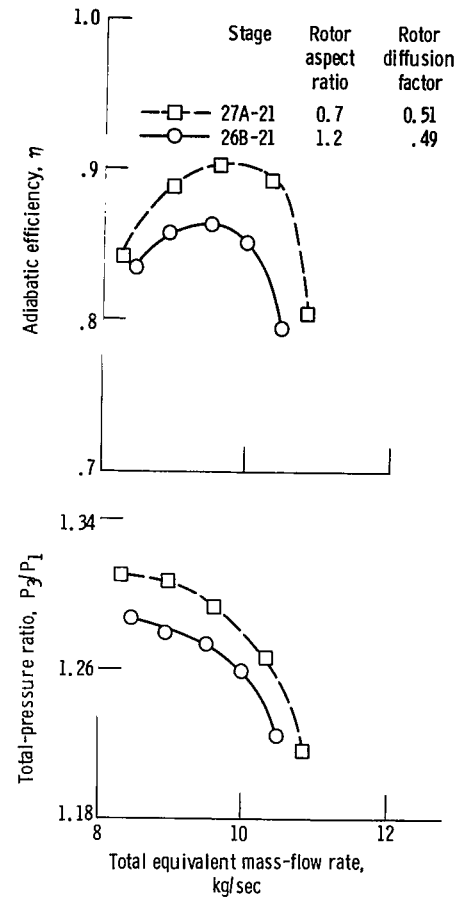
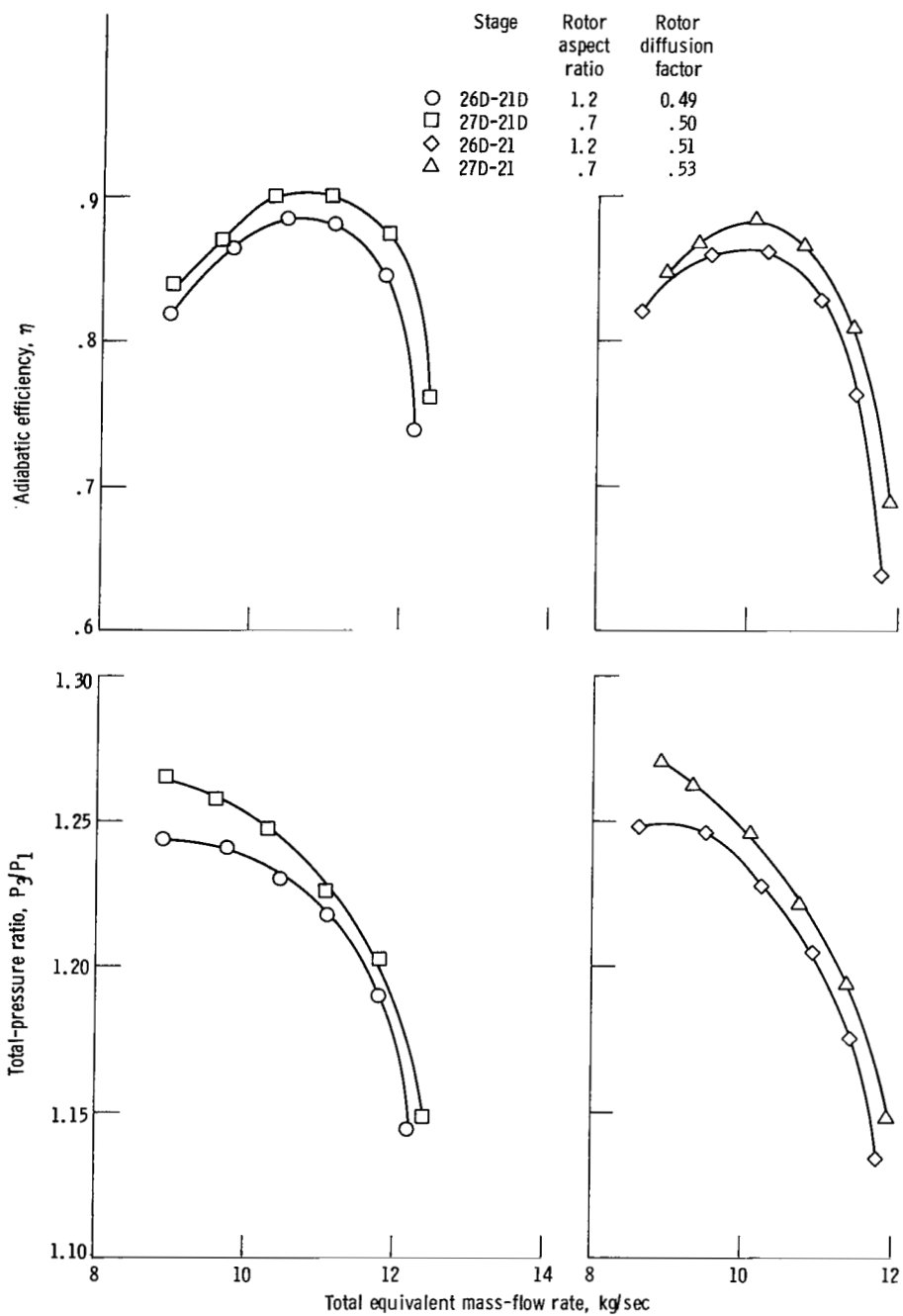

Figure 68. - Effect of rotor aspect ratio on stage performance at constant solidity for stages 27A-21 and 26B-21. Wheel speed, 100 percent of design; rotor solidity, 1.8; stator solidity, 1.8.



(a) Rotor solidity, 0.9; stator solidity, 0.9.

(b) Rotor solidity, 0.9; stator solidity, 1.8.

Figure 69. - Effect of rotor aspect ratio on stage performance at constant solidity for stages 26D-21D, 27D-21D, 26D-21, and 27D-21. Wheel speed, 100 percent of design.

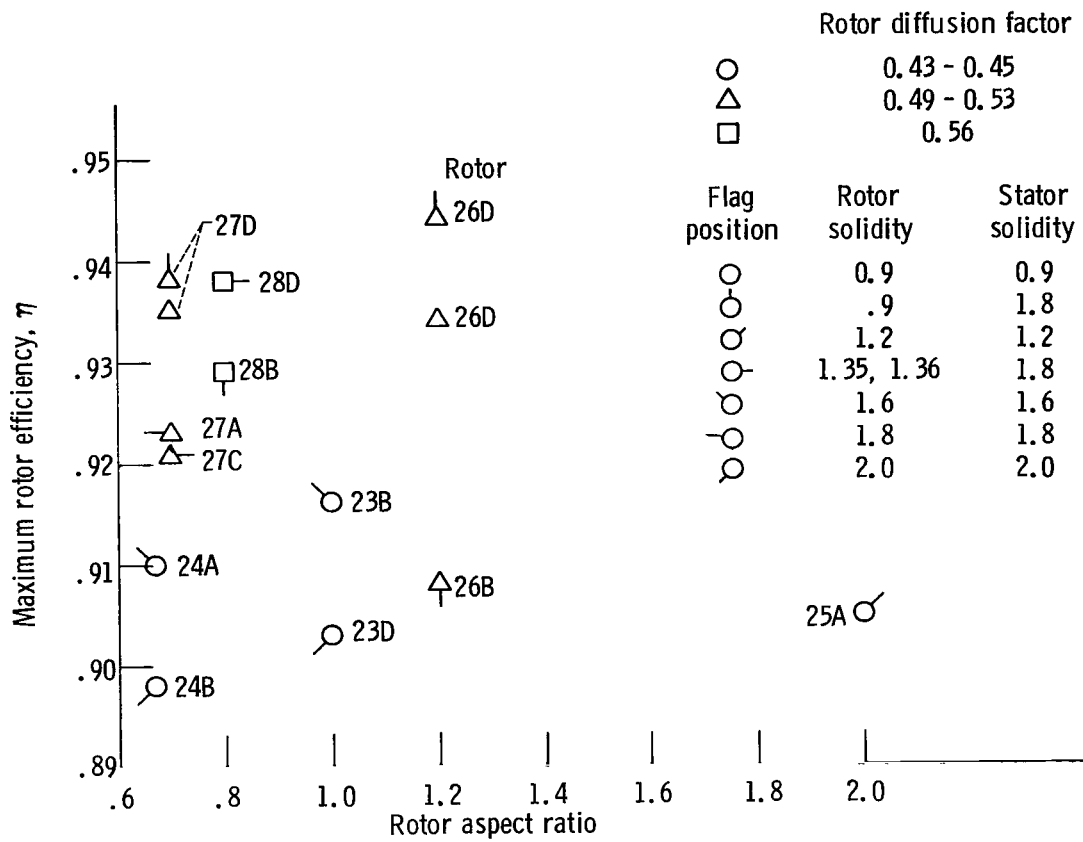

Figure 70. - Effect of aspect ratio, diffusion factor, and solidity on rotor performance.

1. Report No. NASA TP-1523		2. Government Accession No.		3. Recipient's Catalog No.	
4. Title and Subtitle EFFECTS OF DIFFUSION FACTOR, ASPECT RATIO, AND SOLIDITY ON OVERALL PERFORMANCE OF 14 COMPRESSOR MIDDLE STAGES				5. Report Date September 1979	
7. Author(s) Werner R. Britsch, Walter M. Osborn, and Mark R. Laessig				6. Performing Organization Code	
				8. Performing Organization Report No. E-9943	
9. Performing Organization Name and Address National Aeronautics and Space Administration Lewis Research Center Cleveland, Ohio 44135				10. Work Unit No. 505-04	
				11. Contract or Grant No.	
12. Sponsoring Agency Name and Address National Aeronautics and Space Administration Washington, D. C. 20546				13. Type of Report and Period Covered Technical Paper	
				14. Sponsoring Agency Code	
15. Supplementary Notes					
16. Abstract <p>The effects of diffusion factor, aspect ratio, and solidity on rotor and stage performance have been evaluated for 14 subsonic compressor middle stages with a hub-tip ratio of 0.8 and a design tip speed of 243.8 meters per second. Peak rotor efficiencies ranged from 0.898 to 0.944. Peak stage efficiencies ranged from 0.850 to 0.902, and stage stall margins were generally above 15 percent.</p>					
17. Key Words (Suggested by Author(s)) Turbomachinery Compressors Axial flow compressors Compressor middle stages			18. Distribution Statement Unclassified - unlimited STAR Category 07		
19. Security Classif. (of this report) Unclassified		20. Security Classif. (of this page) Unclassified		21. No. of Pages 147	22. Price* A07

National Aeronautics and
Space Administration

THIRD-CLASS BULK RATE

Postage and Fees Paid
National Aeronautics and
Space Administration
NASA-451



Washington, D.C.
20546

Official Business
Penalty for Private Use

8 1 10, A, 091179 S00903DS
DEPT OF THE AIR FORCE
AF WEAPONS LABORATORY
ATTN: TECHNICAL LIBRARY (SUL)
KIRTLAND AFB NM 87117

S

NASA

POSTMASTER: If Undeliverable (Section 158
Postal Manual) Do Not Return
