

NASA Contractor Report 3144

(NASA-CR-3144) A COMPILATION AND ANALYSIS
OF HELICOPTER HANDLING QUALITIES DATA.
VOLUME 1: DATA COMPILATION Report, Sep.
1976 - Feb. 1978 (Systems Technology, Inc.,
Mountain View, Calif.) 387 p HC A17/MF A01

N80-11097

Unclas
40015

H1/08

A Compilation and Analysis of Helicopter Handling Qualities Data

Volume One: Data Compilation

Robert K. Heffley, Wayne F. Jewell,
John M. Lehman, and Richard A. Van Winkle
Systems Technology, Inc.
Mountain View, California

Prepared for
Ames Research Center
under Contract NAS2-9344

NASA

National Aeronautics
and Space Administration

Scientific and Technical
Information Branch

1979

REPRODUCED BY
NATIONAL TECHNICAL
INFORMATION SERVICE
U.S. DEPARTMENT OF COMMERCE
SPRINGFIELD, VA. 22161

1. Report No. NASA CR-3144	2. Government Accession No.	3. Recipient's Catalog No. 180-11097
4. Title and Subtitle A COMPILATION AND ANALYSIS OF HELICOPTER HANDLING QUALITIES DATA. Volume One: Data Compilation	5. Report Date August 1979	6. Performing Organization Code
	7. Author(s) Robert K. Heffley, Wayne F. Jewell, John M. Lehman, Richard A. Van Winkle	8. Performing Organization Report No. TR 1087-1
9. Performing Organization Name and Address Systems Technology, Inc. 2672 Bayshore-Frontage Road, Suite 505 Mountain View, California 94043	10. Work Unit No.	11. Contract or Grant No. NAS2-9344
	12. Sponsoring Agency Name and Address National Aeronautics and Space Administration Ames Research Center Moffett Field, CA 94035	13. Type of Report and Period Covered Contractor Report
15. Supplementary Notes		
16. Abstract A compilation and an analysis of helicopter handling qualities data are presented in two volumes. This, the first volume, contains a collection of basic descriptive data, stability derivatives, and transfer functions for a six-degrees-of-freedom, quasi-static model. The data are arranged in a common, compact format for each of the five helicopters represented. The vehicles include the OH-6A, BO-105, AH-1G, UH-1H, and CH-53D. Basic data were supplied under separate contracts by the manufacturer or licensee of each helicopter. The second volume analyzes the data using multiloop, manual control methods. A general compensatory loop structure is applied to coupled longitudinal-lateral-directional equations in such a way that key handling qualities features can be examined directly. But the overall mathematical complexity is reduced from that of the basic vehicle model. Extensive use is made of constrained state variable relationships and approximate factors in order to gain physical insight.		
17. Key Words (Suggested by Author(s)) Helicopters Handling Qualities Stability and Control Aerodynamic Derivatives	OH-6A BO-105 AH-1G UH-1H CH-53D	18. Distribution Statement UNCLASSIFIED - UNLIMITED Star Category - 08
19. Security Classif. (of this report) Unclassified	20. Security Classif. (of this page) Unclassified	21. No. of Pages 386
		22. Price* \$13.00

*For sale by the National Technical Information Service, Springfield, Virginia 22161

NASA-Langley, 1979

NOTICE

THIS DOCUMENT HAS BEEN REPRODUCED FROM THE BEST COPY FURNISHED US BY THE SPONSORING AGENCY. ALTHOUGH IT IS RECOGNIZED THAT CERTAIN PORTIONS ARE ILLEGIBLE, IT IS BEING RELEASED IN THE INTEREST OF MAKING AVAILABLE AS MUCH INFORMATION AS POSSIBLE.

1
1-a

FOREWORD

The preparation of this report was performed under NASA Contract NAS2-9344 with the joint sponsorship of the Aeromechanics Laboratory of the U. S. Army Research and Technology Laboratories (AVRADCOM) and NASA Ames Research Center. The Contract Technical Monitor was David L. Key, and the Systems Technology, Inc., Project Engineer was Robert K. Heffley. Work on this project was accomplished during the period from September 1976 to February 1978.

The author wishes to thank the following individuals for their contributions and help in preparing this volume: John M. Davis of the Aeromechanics Laboratory of the U. S. Army Research and Technology Laboratories; Linda James of Radu Data Service; and Sharon A. Duerksen of Systems Technology, Inc.

Preceding page blank

ABSTRACT

A compilation and an analysis of helicopter handling qualities data are presented in two volumes. This, the first volume, contains a collection of basic descriptive data, stability derivatives, and transfer functions for a six-degrees-of-freedom, quasi-static model. The data are arranged in a common, compact format for each of the five helicopters represented. The vehicles include the OH-6A, BO-105, AH-1G, UH-1H, and CH-53D. Basic data were supplied under separate contracts by the manufacturer or licensee of each helicopter. The second volume analyzes the data using multiloop, manual control methods. A general compensatory loop structure is applied to coupled longitudinal-lateral-directional equations in such a way that key handling qualities features can be examined directly. But the overall mathematical complexity is reduced from that of the basic vehicle model. Extensive use is made of constrained state variable relationships and approximate factors in order to gain physical insight.

TABLE OF CONTENTS

Section		Page
I	INTRODUCTION	1
	A. Background Information	2
	B. Stability and Control Derivatives	4
	C. Transfer Function Factors	11
II	HUGHES OH-6A	19
III	BOEING VERTOL BO-105C	67
IV	BELL AH-1G	115
V	BELL UH-1H	213
VI	SIKORSKY CH-53D	303
	REFERENCES	358
Appendix		
A	PROCEDURE FOR FORMULATING EQUATIONS OF MOTION	359
B	ANALYSIS OF MULTILoop SYSTEM RELATIONSHIPS	371

LIST OF TABLES

		Page
I-1	General Layout of Stability and Control Derivative Data	7
I-2	Conversion Factors	8
I-3	SI Units for Numerical Values of Stability and Control Derivatives	9
I-4	US Units for Numerical Values of Stability and Control Derivatives	10
I-5	The Extensive List of Control and Gust Numerators	13
I-6	The Abbreviated List of Control Numerators	15
II-1	OH-6A Descriptive Data	20
II-2	OH-6A Index of Flight Conditions for Derivatives and Transfer Function Factors	25
II-3	OH-6A Stability and Control Derivatives — SI Units	26
II-4	OH-6A Stability and Control Derivatives — US Units	35
II-5	OH-6A Transfer Function Factors	44
III-1	BO-105C Descriptive Data	68
III-2	BO-105C Index of Flight Conditions for Derivatives and Transfer Function Factors	73
III-3	BO-105C Stability and Control Derivatives — SI Units	74
III-4	BO-105C Stability and Control Derivatives — US Units	84
III-5	BO-105C Transfer Function Factors	94
IV-1	AH-1G Descriptive Data	116
IV-2	AH-1G Index of Flight Conditions for Derivatives and Transfer Function Factors	121
IV-3	AH-1G Stability and Control Derivatives — SI Units	122

LIST OF TABLES (Concluded)

		Page
IV-4	AH-1G Stability and Control Derivatives — US Units . .	143
IV-5	AH-1G Transfer Function Factors	164
V-1	UH-1H Descriptive Data	214
V-2	UH-1H Index of Flight Conditions for Derivatives and Transfer Function Factors	219
V-3	UH-1H Stability and Control Derivatives — SI Units . .	220
V-4	UH-1H Stability and Control Derivatives — US Units . .	241
V-5	UH-1H Transfer Function Factors	262
VI-1	CH-53D Descriptive Data	304
VI-2	CH-53D Index of Flight Conditions for Derivatives and Transfer Function Factors	309
VI-3	CH-53D Stability and Control Derivatives — SI Units . .	310
VI-4	CH-53D Stability and Control Derivatives — US Units . .	316
VI-5	CH-53D Transfer Function Factors	322
A-1	Matrix Equations of Motion	365
A-2	Matrix Elements	366
A-3	Sample of Equations of Motion and Transformation Matrices (OH-6A, Hover)	369
A-4	Sample of Equations of Motion and Transformation Matrices (OH-6A, 60 kt)	370

LIST OF FIGURES

		Page
I-1	Assumed Pilot/Vehicle Loop Structure for Low Speed Flight	14
II-1	OH-6A General Arrangement	21
II-2	OH-6A Control System Description	22
II-3	OH-6A Loading Summary	24
III-1	BO-105C General Arrangement	69
III-2	BO-105C Control System Description	70
III-3	BO-105C Loading Summary	72
IV-1	AH-1G General Arrangement	117
IV-2	AH-1G Control System Description	118
IV-3	AH-1G Loading Summary	120
V-1	UH-1H General Arrangement	215
V-2	UH-1H Control System Description	216
V-3	UH-1H Loading Summary	218
VI-1	CH-53D General Arrangement	305
VI-2	CH-53D Control System Description	306
VI-3	CH-53D Loading Summary	308

LIST OF ABBREVIATIONS

AFCS	Automatic Flight Control System (CH-53D)
AND	Aircraft nose down
ANU	Aircraft nose up
BL	Butt line
FRL	Fuselage reference line
FS	Fuselage station
HD	Heave damping
MBB	Messerschmitt-Bölkow-Blohm
NOE	Nap of the earth
P	Phugoid (longitudinal)
PD	Pitch damping
PL	Lateral phugoid
R	Roll damping
RRA	Rotor reference axis (BO-105C)
SI	International system of units (Système International)
SP	Short period
TED	Trailing edge down
TEU	Trailing edge up
US	Standard U.S. units
WL	Water line
YD	Yaw damping

LIST OF SYMBOLS

A_{1s}	Lateral cyclic swashplate deflection
B_{1s}	Longitudinal cyclic swashplate deflection
DA	Also δ_A
DB	Also δ_B
DC	Also δ_c
DP	Also δ_p
g	Gravity constant
h	Altitude
$I(\)$	Moment of inertia about () axis
L	Rolling moment
$L(\)$	Dimensional rolling moment derivative, $\frac{1}{I_x} \frac{\partial L}{\partial(\)}$
M	Pitching moment
$M(\)$	Dimensional pitching moment derivative, $\frac{1}{I_y} \frac{\partial M}{\partial(\)}$
m	Mass
N	Yawing moment
$N(\)$	Dimensional yawing moment derivative, $\frac{1}{I_z} \frac{\partial N}{\partial(\)}$
PHI	Also ϕ
PSI	Also ψ
p	Angular rate about body x-axis
q	Angular rate about body y-axis
r	Angular rate about body z-axis
THE	Also θ

LIST OF SYMBOLS (Continued)

U	Total body axis x-velocity, $U_0 + u$
UG	Also u_g
u	Perturbation x-velocity
u_g	x-axis gust component (earth fixed reference frame)
V	Total body axis y-velocity, $V_0 + v$
VG	Also v_g
v	Perturbation y-velocity
v_g	y-axis gust component (earth fixed reference frame)
W	Total body axis z-velocity, $W_0 + w$
WG	Also w_g
w	Perturbation z-velocity
w_g	z-axis gust component (earth fixed reference frame)
X	Force along x-axis
$X(\)$	Dimensional x-force derivative, $\frac{1}{m} \frac{\partial X}{\partial(\)}$
XD	Also \dot{x}
x	Horizontal body axis (FRL axis system), positive forward
\dot{x}	Velocity along x-axis (earth fixed reference frame)
Y	Force along y-axis
$Y(\)$	Dimensional y-force derivative, $\frac{1}{m} \frac{\partial Y}{\partial(\)}$, also pilot compensation transfer function for () motion
YD	Also \dot{y}
y	Lateral body axis (FRL axis system), positive toward right side of aircraft
\dot{y}	Velocity along y-axis (earth fixed reference frame)
Z	Force along z-axis
$Z(\)$	Dimensional z-force derivative, $\frac{1}{m} \frac{\partial Z}{\partial(\)}$

LIST OF SYMBOLS (Concluded)

ZD	Also \dot{z}
z	Vertical body axis (FRL axis system), positive downward
\dot{z}	Velocity along z-axis (earth fixed reference frame)
α	Angle of attack
β	Sideslip
γ	Flight path angle
δ	Control deflection
ζ	Damping ratio
Θ	Total pitch angle $\theta + \theta_0$
θ	Perturbation pitch Euler angle
Φ	Total roll angle $\phi + \phi_0$
ϕ	Perturbation Euler roll angle
Ψ	Total yaw angle $\psi + \psi_0$
ψ	Perturbation Euler yaw angle
ω	Natural frequency
\triangleq	Defined as

SUBSCRIPTS

A	Lateral cyclic cockpit control
B	Longitudinal cyclic cockpit control
c	Collective cockpit control, also commanded response
MR	Main rotor
o	Initial condition, steady state
p	Rudder pedal
TR	Tail rotor

SECTION I

INTRODUCTION

This is the first volume of a two volume series presenting a compilation and analysis of helicopter handling qualities data. In this volume basic handling qualities data are given for five single rotor helicopters representing various combinations of sizes, intended missions, control and augmentation systems, and rotor system concepts. The second volume (Ref. 1) analyzes a portion of the compiled data using multiloop, manual control methods. In fact, the main purpose of Volume Two is to serve as a guide to one way in which the data can be used.

The data compilation is a condensation of individual packages of six-degrees-of-freedom, quasi-static data procured from each respective helicopter manufacturer by the Aeromechanics Laboratory of the U. S. Army Research and Technology Laboratories (AVRADCOM) and the National Aeronautics and Space Administration (NASA). The data have been developed into a form which is useful for analysis of manual control in the low speed, low altitude flight regime, especially nap-of-the-earth (NOE) operation. An effort has been made to maintain a consistent data format among all five subject vehicles.

The five helicopters included in this volume are the:

- Hughes OH-6A (Cayuse)
- Boeing-Vertol* BO-105C
- Bell AH-1G (HueyCobra)
- Bell UH-1H (Huey)
- Sikorsky CH-53D (Sea Stallion).

The data presented for each helicopter include a verbal description of important or unusual features affecting handling qualities, a geometrical description, a flight control system schematic, stability and control system

* Sold under license from Messerschmitt-Bölkow-Blohm (MBB).

derivatives, and transfer function factors. Stability and control derivatives are given for all flight conditions included in the original manufacturers' data packages (a total of nearly 200 conditions). Transfer function factors are given for selected flight conditions and for state variables most relevant to head-up flight reference at low altitude. These data are arranged by helicopter in each of the subsequent sections.

The formats used in presenting these helicopter data have been carefully planned, first to maximize their direct usefulness, and second to maximize compactness. For the most part, notation and sign conventions are borrowed directly from Ref. 2. In the following pages of introduction the report format is explained in some detail in order to facilitate its use. The explanation of format is divided into background information, stability and control derivatives, and transfer function data.

A. BACKGROUND INFORMATION

Each helicopter section contains several pages of background information which provides descriptive material of a general nature in addition to a definition of configurations and flight conditions for the tables of derivatives and transfer function factors. The primary sources of information for each respective vehicle are Refs. 3, 4, 5, and 6. (These are the sole sources for derivative data.) Miscellaneous pieces of descriptive information are drawn, however, from the other sources as noted.

The verbal description presented at the beginning of each section gives a brief sketch of the vehicle's intended mission, size, propulsion system, and any unusual aspects. Important features of the control system as they relate to vehicle handling are also described.

The first table in each section lists important descriptive data concerning the rotor system and airfoils. These data have been taken from the primary sources except where noted.

A general arrangement drawing is included to show important airframe design features and to define the commonly used fuselage reference line (FRL) axis system. FRL axes are scaled in terms of fuselage station (FS), butt line (BL), and waterline (WL). FS, BL, and WL scales are parallel to

the x, y, and z axes respectively. (The axis system for derivatives has its origin at the vehicle center of gravity.)

The second figure in each section describes the flight control and augmentation systems. The figure includes a block diagram and a tabulation of cockpit controller characteristics. The values given in block diagrams correspond to those used in computation of control derivatives and transfer function factors and are taken directly from the primary data sources (except where algebraic manipulation was required to establish a common format). In the block diagrams the units of cockpit control deflections are expressed as percentage of maximum control travel and all angular quantities are expressed in degrees. (Note that for tabulated transfer function factors units are inches for control deflection and radians for angles.) The control system description given for each helicopter assumes a cockpit-control-fixed condition. Thus, force feedback from either the rotor system (as in the case of the OH-6A) or from an automatic trim system (CH-53D) is not modeled. Where a fixed control force gradient is used (BO-105, AH-1G, and UH-1H) the values are given.

A loading summary is presented in the third figure in each section which describes the specific loading configurations included in the tabulated derivative data in relation to the allowable weight and cg envelope.

This is followed by a second table, a master index of flight conditions for the tabulated stability and control derivative data and transfer function data. A single set of flight condition case numbers (1 to 199) is used to encompass all five helicopters. This avoids confusion of a common case number between two different vehicles. The case numbers are assigned as follows:

VEHICLE	CASE NUMBERS
OH-6A	1 through 26
BO-105C	27 through 55
AH-1G	56 through 118
UH-1H	119 through 181
CH-53D	182 through 199

The third and fourth tables in each section contain stability and control derivatives in SI units and US units, respectively. The fifth table lists all transfer function data. The specific format of these three tables is defined and discussed below.

B. STABILITY AND CONTROL DERIVATIVES

Stability and control derivatives can be presented in a variety of forms involving various reference frames, state variables, and dimensionalization schemes.

In studying aircraft dynamics one particularly useful way of dimensionalizing derivatives is to reduce force and moment derivatives to the dimensions of specific force and specific moment, i.e., normalizing force and moment by mass and moment of inertia, respectively. This more directly relates the derivatives to motion quantities, and, by properly choosing state variables, many of the derivatives themselves have useful dimensions of inverse time or frequency.

In selecting a reference frame for the stability derivatives there are two popular choices, the stability axis system or the fuselage reference line (FRL) axis system. The stability axis system is attractive, at least for conventional aircraft. Vertical velocity Coriolis terms do not appear in the resulting equations of motion (e.g., $W_0 q$) which simplifies the approximate factors relationships, such as those given in Ref. 2. In addition, some stability axis derivatives are, themselves, easily estimated from certain basic parameters (such as C_L or C_{L_α} in the case of airplanes). Unfortunately, the stability axis system has difficulties at low forward velocities where the trim angle of attack can take on large values. This is, of course, one important regime of interest for helicopters. Therefore, we considered an alternative.

Fuselage reference line axis (often referred to as body axis) derivatives, while less desirable for conventional aircraft, may be better suited to helicopters. The derivatives themselves are better behaved at low speeds. That is, derivative values do not radically change due to small changes in flight condition. Also, most of the FRL derivatives are approximately

equal to stability axis derivatives so long as α_0 is small. Perhaps the most compelling argument in their favor, though, is that FRL axis derivatives appear to be the most widely used for rotary wing aircraft.

Another aspect in choosing the form of stability and control derivatives is use of primed versus unprimed derivatives. Primed derivatives incorporate the product of inertia effects and eliminate their explicit appearance in the equations of motion. They are defined as:

$$L'(\cdot) = \frac{L(\cdot) + \frac{I_{xz}}{I_x} N(\cdot)}{1 - \frac{I_{xz}^2}{I_x I_z}}$$

$$N'(\cdot) = \frac{N(\cdot) + \frac{I_{xz}}{I_z} L(\cdot)}{1 - \frac{I_{xz}^2}{I_x I_z}}$$

If the aircraft is symmetric about the x-z plane, then only an I_{xz} cross product of inertia term is present and only the roll and yaw equations are affected. Primed lateral-directional stability and control derivatives, especially in the stability axis system, thus have the advantage of conveying more information about the overall airplane dynamics than do their unprimed counterparts. It should be added that primed derivatives are, in fact, widely used.

In choosing the independent variables of the derivatives it is the convention to simply use the translational and angular velocities corresponding to the axis system used. For the FRL axis system these variables are u, v, w, p, q, r. Note, however, that a different set of state variables was chosen for transfer function factors.

Control variables can be expressed as either cockpit controller deflections, control surface deflections, or rotor blade pitch. Each appears equally popular, but the first is most relevant to handling qualities matters.

A final issue is the system of units. While US units are customary, it is desirable to include SI units also. Thus, two sets of stability derivative tables are presented, one for each unit system.

To summarize:

- The standard form of dimensional body-fixed stability and control derivatives is utilized
- These derivatives are taken with respect to an FRL axis system
- Lateral-directional moment derivatives are primed
- Control variables correspond to cockpit controller deflections
- Both US and SI units are presented.

Tabulations of stability and control derivatives are given in Tables -3 and -4 in each of the helicopter sections (II through VI) for SI units and US units, respectively. The general layout of data for each flight condition is shown in Table I-1. This consists of:

- A line identifying the flight condition
- An array of trim conditions — angles and velocities
- An array of stability and control derivatives which is partitioned into longitudinal and lateral-directional parts.

Conversion factors used throughout the data compilation are shown in Table I-2.

The units for each quantity displayed in stability and control derivative tables are shown in Table I-3 for SI units and Table I-4 for US units.

TABLE I-1

GENERAL LAYOUT OF STABILITY AND CONTROL DERIVATIVE DATA

Identi- fication	CASE 4	O KT	LEVEL FLIGHT AT SEA LEVEL	2550 LB	MID CG										
Trim Angles	PHI	THETA	PSI	ALPHA	BETA	GAMMA	θ _{MR}	B _{1S}	A _{1S}	θ _{TR}					
	φ _o	θ _o	ψ _o	α _o	β _o	γ _o	θ _{MR}	B _{1S}	A _{1S}	θ _{TR}					
Trim Velocities	Euler Angles			Relative Wind		Flight Path		Control Displacement							
	XDOT			ZDOT	UO	VO	WO	VTO							
	ẋ _o			ż _o	U _o	V _o	W _o	V _{T_o}							
Longitudinal Derivatives	Earth Axis			Body Axis			Total								
		U	W	Q	V	P	R	DC	DB	DA	DP				
	X	X_u	X_w	X_q	X_v	X_p	X_r	X_{δ_c}	X_{δ_B}	X_{δ_A}	X_{δ_P}				
	Z	Z_u	Z_w	Z_q	Z_v	Z_p	Z_r	Z_{δ_c}	Z_{δ_B}	Z_{δ_A}	Z_{δ_P}				
	M	M_u	M_w	M_q	M_v	M_p	M_r	M_{δ_c}	M_{δ_B}	M_{δ_A}	M_{δ_P}				
	Lateral- Directional Derivatives	Y	Y_u	Y_w	Y_q	Y_v	Y_p	Y_r	Y_{δ_c}	Y_{δ_B}	Y_{δ_A}	Y_{δ_P}			
L'		L'_u	L'_w	L'_q	L'_v	L'_p	L'_r	L'_{δ_c}	L'_{δ_B}	L'_{δ_A}	L'_{δ_P}				
N'		N'_u	N'_w	N'_q	N'_v	N'_p	N'_r	N'_{δ_c}	N'_{δ_B}	N'_{δ_A}	N'_{δ_P}				
Stability Derivatives						Control Derivatives									

Solid boxes enclose on-diagonal stability derivatives and direct control derivatives

Dashed boxes enclose usual three degrees of freedom derivatives

TABLE I-2
CONVERSION FACTORS

LENGTH $\frac{m}{ft} = .3048$

MASS/
WEIGHT $\frac{kg}{lb} = .45359237$

MOMENT OF
INERTIA $\frac{kg-m^2}{slug-ft^2} = .45359237 \times 9.80665 \times .3048 \doteq 1.3558$

GRAVITY $g = 9.80665 \text{ m/sec}^2 = \frac{9.80665}{.3048} \text{ ft/sec}^2 \doteq 32.174 \text{ ft/sec}^2$

VELOCITY $\frac{kt}{m/sec} = \frac{1852}{3600} \doteq .514$

$\frac{kt}{ft/sec} = \frac{1852}{3600 \times .3048} \doteq 1.688$

FORCE $\frac{N}{lb} = .45359237 \times 9.80665 \doteq 4.448$

TABLE I-3

SI UNITS FOR NUMERICAL VALUES OF STABILITY AND CONTROL DERIVATIVES

CASE 4 0 KT LEVEL FLIGHT AT SEA LEVEL 1157 MG MID CG

PHI THETA PSI ALPHA BETA GAMMA EMR BIS A1S eTR
 ϕ_0 (deg) θ_0 (deg) ψ_0 (deg) α_0 (deg) β_0 (deg) γ_0 (deg) θ_{MR} (deg) B_{1S} (deg) A_{1S} (deg) θ_{TR} (deg)

XDOT ZDOT UO VO W0 VTO
 \dot{x}_0 (m/sec) \dot{z}_0 (m/sec) U_0 (m/sec) V_0 (m/sec) W_0 (m/sec) V_{T0} (m/sec)

U

	U	W	Q	V	P	R	DC	DB	DA	DP
X	$X_u(1/sec)$	$X_w(1/sec)$	$X_q(\frac{m}{sec-rad})$	$X_v(1/sec)$	$X_p(\frac{m}{sec-rad})$	$X_r(\frac{m}{sec-rad})$	$X_{\delta_c}(\frac{m}{sec^2-cm})$	$X_{\delta_B}(\frac{m}{sec^2-cm})$	$X_{\delta_A}(\frac{m}{sec^2-cm})$	$X_{\delta_P}(\frac{m}{sec^2-cm})$
Z	$Z_u(1/sec)$	$Z_w(1/sec)$	$Z_q(\frac{m}{sec-rad})$	$Z_v(1/sec)$	$Z_p(\frac{m}{sec-rad})$	$Z_r(\frac{m}{sec-rad})$	$Z_{\delta_c}(\frac{m}{sec^2-cm})$	$Z_{\delta_B}(\frac{m}{sec^2-cm})$	$Z_{\delta_A}(\frac{m}{sec^2-cm})$	$Z_{\delta_P}(\frac{m}{sec^2-cm})$
M	$M_u(\frac{rad}{m-sec})$	$M_w(\frac{rad}{m-sec})$	$M_q(1/sec)$	$M_v(\frac{rad}{m-sec})$	$M_p(1/sec)$	$M_r(1/sec)$	$M_{\delta_c}(\frac{rad}{sec^2-cm})$	$M_{\delta_B}(\frac{rad}{sec^2-cm})$	$M_{\delta_A}(\frac{rad}{sec^2-cm})$	$M_{\delta_P}(\frac{rad}{sec^2-cm})$
Y	$Y_u(1/sec)$	$Y_w(1/sec)$	$Y_q(\frac{m}{sec-rad})$	$Y_v(1/sec)$	$Y_p(\frac{m}{sec-rad})$	$Y_r(\frac{m}{sec-rad})$	$Y_{\delta_c}(\frac{m}{sec^2-cm})$	$Y_{\delta_B}(\frac{m}{sec^2-cm})$	$Y_{\delta_A}(\frac{m}{sec^2-cm})$	$Y_{\delta_P}(\frac{m}{sec^2-cm})$
L'	$L'_u(\frac{rad}{m-sec})$	$L'_w(1/sec)$	$L'_q(1/sec)$	$L'_v(\frac{rad}{m-sec})$	$L'_p(1/sec)$	$L'_r(1/sec)$	$L'_{\delta_c}(\frac{rad}{sec^2-cm})$	$L'_{\delta_B}(\frac{rad}{sec^2-cm})$	$L'_{\delta_A}(\frac{rad}{sec^2-cm})$	$L'_{\delta_P}(\frac{rad}{sec^2-cm})$
N'	$N'_u(\frac{rad}{m-sec})$	$N'_w(1/sec)$	$N'_q(1/sec)$	$N'_v(\frac{rad}{m-sec})$	$N'_p(1/sec)$	$N'_r(1/sec)$	$N'_{\delta_c}(\frac{rad}{sec^2-cm})$	$N'_{\delta_B}(\frac{rad}{sec^2-cm})$	$N'_{\delta_A}(\frac{rad}{sec^2-cm})$	$N'_{\delta_P}(\frac{rad}{sec^2-cm})$

TABLE I-4

US UNITS FOR NUMERICAL VALUES OF STABILITY AND CONTROL DERIVATIVES

CASE	4	0 KT	LEVEL FLIGHT AT SEA LEVEL	2550 LB	MID CG						
		PHI	THETA	PSI	ALPHA	BETA	GAMMA	EMR	BIS	AIS	EMR
		ϕ_0 (deg)	θ_0 (deg)	ψ_0 (deg)	α_0 (deg)	β_0 (deg)	γ_0 (deg)	ϵ_{MR} (deg)	B_1 (deg)	A_1 (deg)	ϵ_{MR} (deg)
		XDOT	ZDOT	UDOT	VO	WO	VTO				
		\dot{x}_0 (ft/sec)	\dot{z}_0 (ft/sec)	\dot{u}_0 (ft/sec)	V_0 (ft/sec)	W_0 (ft/sec)	V_{T0} (ft/sec)				
X	X_u (1/sec)	X_w (1/sec)	X_q (ft/sec-rad)	X_v (1/sec)	X_p (ft/sec-rad)	X_r (ft/sec-rad)	$X_{\dot{c}}$ (ft/sec ² -in)	$X_{\dot{b}}$ (ft/sec ² -in)	$X_{\dot{a}}$ (ft/sec ² -in)	$X_{\dot{p}}$ (ft/sec ² -in)	$X_{\dot{q}}$ (ft/sec ² -in)
Z	Z_u (1/sec)	Z_w (1/sec)	Z_q (ft/sec-rad)	Z_v (1/sec)	Z_p (ft/sec-rad)	Z_r (ft/sec-rad)	$Z_{\dot{c}}$ (ft/sec ² -in)	$Z_{\dot{b}}$ (ft/sec ² -in)	$Z_{\dot{a}}$ (ft/sec ² -in)	$Z_{\dot{p}}$ (ft/sec ² -in)	$Z_{\dot{q}}$ (ft/sec ² -in)
M	M_u (rad/ft-sec)	M_w (rad/ft-sec)	M_q (1/sec)	M_v (rad/ft-sec)	M_p (1/sec)	M_r (1/sec)	$M_{\dot{c}}$ (rad/sec ² -in)	$M_{\dot{b}}$ (rad/sec ² -in)	$M_{\dot{a}}$ (rad/sec ² -in)	$M_{\dot{p}}$ (rad/sec ² -in)	$M_{\dot{q}}$ (rad/sec ² -in)
Y	Y_u (1/sec)	Y_w (1/sec)	Y_q (ft/sec-rad)	Y_v (1/sec)	Y_p (ft/sec-rad)	Y_r (ft/sec-rad)	$Y_{\dot{c}}$ (ft/sec ² -in)	$Y_{\dot{b}}$ (ft/sec ² -in)	$Y_{\dot{a}}$ (ft/sec ² -in)	$Y_{\dot{p}}$ (ft/sec ² -in)	$Y_{\dot{q}}$ (ft/sec ² -in)
L'	L'_u (rad/ft-sec)	L'_w (1/sec)	L'_q (1/sec)	L'_v (rad/ft-sec)	L'_p (1/sec)	L'_r (1/sec)	$L'_{\dot{c}}$ (rad/sec ² -in)	$L'_{\dot{b}}$ (rad/sec ² -in)	$L'_{\dot{a}}$ (rad/sec ² -in)	$L'_{\dot{p}}$ (rad/sec ² -in)	$L'_{\dot{q}}$ (rad/sec ² -in)
N'	N'_u (rad/ft-sec)	N'_w (1/sec)	N'_q (1/sec)	N'_v (rad/ft-sec)	N'_p (1/sec)	N'_r (1/sec)	$N'_{\dot{c}}$ (rad/sec ² -in)	$N'_{\dot{b}}$ (rad/sec ² -in)	$N'_{\dot{a}}$ (rad/sec ² -in)	$N'_{\dot{p}}$ (rad/sec ² -in)	$N'_{\dot{q}}$ (rad/sec ² -in)

C. TRANSFER FUNCTION FACTORS

Transfer function factors are provided to enable a reasonably direct analysis of a wide range of handling qualities features. This required a careful choice of transfer function states and of transfer function numerator combinations.

The states to be associated with stability and control derivatives do not necessarily correspond to those used by the pilot in closing his control loops. For example, the inertial x-velocity in the FRL axis, u , is an appropriate state variable for the aerodynamic derivatives but is not directly perceived by the pilot by outside visual reference nor from cockpit instruments. Thus, a body-fixed FRL axis u transfer function is of little use in analyzing the pilot's control of the forward velocity or position.

In choosing the states to be used in analyses, the determining factor is taken to be the pilot's direct visual reference. In the case of a helicopter operating at low speed flight with outside visual reference, the most appropriate set of states is believed to be \dot{x} , \dot{y} , \dot{z} ($\dot{z} = -\dot{h}$), ϕ , θ , and ψ . Thus, velocities are defined with respect to an earth-fixed, earth-aligned reference frame, and angles are defined in terms of the conventional aircraft Euler angle set.

The control variables considered most pertinent are cockpit control deflections which include longitudinal cyclic, δ_P ; lateral cyclic, δ_A ; collective, δ_C ; and pedal, δ_D . As with the state variables chosen, these control variables are directly meaningful to the pilot.

Finally, disturbance variables are defined as airmass velocities in an earth-fixed axis system. These variables are labeled u_g , w_g , v_g , p_g , q_g , and r_g , but differ from the usual body-fixed convention as described in Section 4-6 of Ref. 2. This permits a direct correspondence to a spatially dependent gust description.

Transfer function data are arranged by flight condition according to the master index in the second table in each section. Transfer functions are expressed as factored polynomials of the system denominator and a large number of important control and gust numerators.

At three flight conditions, hover, 20 kt, and 60 kt level flight, an extensive list of control and gust numerators is presented for each helicopter. The extensive list, given in Table I-5, contains 61 control numerators of type zero through type three and 127 gust numerators of type zero through type four. Based on the analysis reported in Volume Two, these numerators were determined to be of potential value in constructing a large number of closed loop pilot/vehicle transfer function relationships for the general loop structure shown in Fig. I-1.

An abbreviated list of transfer function factors for 36 control numerators, as shown in Table I-6, is presented for each helicopter at a number of flight conditions over a range of airspeeds and vertical velocities. Some cases of altitude, weight, and cg variations are included.

The specific format used to describe transfer function numerators and denominators is shown below. Four elements are involved: the descriptor, the high frequency gain, factored roots (first order then second order), and the low frequency gain. The factored roots are expressed in a short hand form. For a quantity enclosed in parentheses:

$$(a) \triangleq (s + a)$$

For the two quantities enclosed in brackets:

$$[\zeta; \omega] \triangleq [s^2 + 2\zeta\omega s + \omega^2]$$

For example, a transfer function denominator which is denoted by:

DENOMINATOR: (0) (.0636) (5.72) [.0426; .287] [.985; 1.66] [.223; 2.63] <.569>

Translates into:

$$\Delta = s(s+.0636)(s+5.72)[s^2+2x.0426x.287s+.287^2] \\ [s^2+2x.985x1.66s+1.66^2][s^2+2x.223x2.63s+2.63^2]$$

TABLE I-5

THE EXTENSIVE LIST OF CONTROL AND GUST NUMERATORS

Control Numerators:

Type 0	$N_{\delta_A}^{\phi}, N_{\delta_B}^{\psi}, N_{\delta_P}^{\psi}, N_{\delta_B}^{\phi}, N_{\delta_P}^{\phi}, N_{\delta_C}^{\phi}, N_{\delta_A}^{\phi}, N_{\delta_P}^{\phi}, N_{\delta_C}^{\phi}, N_{\delta_A}^{\psi}, N_{\delta_B}^{\psi}, N_{\delta_C}^{\psi}$ $N_{\delta_B}^{\psi}, N_{\delta_A}^{\psi}, N_{\delta_C}^{\psi}, N_{\delta_C}^{\psi}, N_{\delta_P}^{\psi}, N_{\delta_B}^{\psi}$
Type I	$N_{\delta_A\delta_B}^{\phi}, N_{\delta_A\delta_P}^{\psi}, N_{\delta_B\delta_P}^{\psi}, N_{\delta_B\delta_P}^{\phi}, N_{\delta_P\delta_B}^{\phi}, N_{\delta_C\delta_B}^{\phi}, N_{\delta_A\delta_P}^{\psi}, N_{\delta_P\delta_A}^{\phi}, N_{\delta_C\delta_A}^{\phi}, N_{\delta_A\delta_B}^{\psi}, N_{\delta_B\delta_A}^{\psi}$ $N_{\delta_C\delta_P}^{\psi}, N_{\delta_C\delta_A}^{\phi}$ $N_{\delta_B\delta_A}^{\psi}, N_{\delta_B\delta_P}^{\psi}, N_{\delta_A\delta_B}^{\phi}, N_{\delta_A\delta_P}^{\psi}, N_{\delta_C\delta_A}^{\psi}, N_{\delta_C\delta_B}^{\phi}, N_{\delta_C\delta_P}^{\psi}, N_{\delta_C\delta_A}^{\phi}, N_{\delta_C\delta_B}^{\phi}, N_{\delta_C\delta_P}^{\psi}, N_{\delta_P\delta_A}^{\psi}, N_{\delta_P\delta_B}^{\phi}$ $N_{\delta_B\delta_A}^{\phi}, N_{\delta_B\delta_P}^{\psi}$
Type II	$N_{\delta_A\delta_B\delta_P}^{\phi}, N_{\delta_C\delta_B\delta_P}^{\psi}, N_{\delta_C\delta_A\delta_P}^{\psi}, N_{\delta_C\delta_A\delta_B}^{\phi}$ $N_{\delta_B\delta_A\delta_P}^{\psi}, N_{\delta_A\delta_B\delta_P}^{\psi}, N_{\delta_C\delta_A\delta_B}^{\psi}, N_{\delta_C\delta_A\delta_P}^{\psi}, N_{\delta_C\delta_B\delta_P}^{\psi}, N_{\delta_C\delta_A\delta_B}^{\phi}, N_{\delta_C\delta_A\delta_P}^{\psi}, N_{\delta_C\delta_B\delta_P}^{\psi}, N_{\delta_P\delta_A\delta_B}^{\phi}, N_{\delta_B\delta_A\delta_P}^{\psi}$
Type III	$N_{\delta_C\delta_A\delta_B\delta_P}^{\phi}, N_{\delta_C\delta_A\delta_B\delta_P}^{\psi}$

Gust Numerators:

Type 0	$N_{u_g}^{\phi}, N_{u_g}^{\psi}, N_{v_g}^{\psi}, N_{v_g}^{\phi}, N_{w_g}^{\phi}, N_{w_g}^{\psi}, N_{w_g}^{\phi}, N_{w_g}^{\psi}, N_{p_g}^{\phi}, N_{p_g}^{\psi}, N_{p_g}^{\phi}, N_{q_g}^{\phi}, N_{q_g}^{\psi}, N_{r_g}^{\phi}$ $N_{r_g}^{\psi}, N_{r_g}^{\phi}, N_{r_g}^{\psi}$ $N_{u_g}^{\psi}, N_{u_g}^{\phi}, N_{v_g}^{\psi}, N_{v_g}^{\phi}, N_{w_g}^{\psi}$
Type I	$N_{u_g\delta_B}^{\phi}, N_{u_g\delta_P}^{\psi}, N_{u_g\delta_A}^{\phi}, N_{u_g\delta_P}^{\psi}, N_{u_g\delta_A}^{\psi}, N_{v_g\delta_B}^{\phi}, N_{v_g\delta_B}^{\psi}, N_{v_g\delta_P}^{\phi}, N_{v_g\delta_A}^{\phi}, N_{v_g\delta_P}^{\psi}, N_{v_g\delta_A}^{\phi}, N_{v_g\delta_B}^{\psi}$ $N_{w_g\delta_B}^{\phi}, N_{w_g\delta_P}^{\psi}, N_{w_g\delta_A}^{\phi}, N_{w_g\delta_P}^{\psi}, N_{w_g\delta_A}^{\psi}, N_{p_g\delta_B}^{\phi}, N_{p_g\delta_B}^{\psi}, N_{p_g\delta_P}^{\phi}, N_{p_g\delta_A}^{\phi}, N_{p_g\delta_P}^{\psi}, N_{p_g\delta_A}^{\phi}, N_{p_g\delta_B}^{\psi}$ $N_{q_g\delta_B}^{\phi}, N_{q_g\delta_P}^{\psi}, N_{q_g\delta_A}^{\phi}, N_{q_g\delta_P}^{\psi}, N_{q_g\delta_A}^{\psi}, N_{r_g\delta_B}^{\phi}, N_{r_g\delta_B}^{\psi}, N_{r_g\delta_P}^{\phi}, N_{r_g\delta_A}^{\phi}, N_{r_g\delta_P}^{\psi}, N_{r_g\delta_A}^{\phi}, N_{r_g\delta_B}^{\psi}$ $N_{u_g\delta_A}^{\psi}, N_{u_g\delta_B}^{\psi}, N_{u_g\delta_P}^{\psi}, N_{u_g\delta_A}^{\phi}, N_{u_g\delta_B}^{\phi}, N_{u_g\delta_P}^{\phi}, N_{v_g\delta_A}^{\psi}, N_{v_g\delta_B}^{\psi}, N_{v_g\delta_P}^{\psi}, N_{w_g\delta_A}^{\psi}, N_{w_g\delta_B}^{\psi}, N_{w_g\delta_P}^{\psi}$ $N_{w_g\delta_A}^{\phi}, N_{w_g\delta_P}^{\phi}, N_{w_g\delta_P}^{\psi}, N_{u_g\delta_C}^{\psi}, N_{u_g\delta_C}^{\phi}$
Type II	$N_{u_g\delta_B\delta_P}^{\psi}, N_{u_g\delta_A\delta_P}^{\psi}, N_{u_g\delta_A\delta_B}^{\phi}, N_{v_g\delta_B\delta_P}^{\psi}, N_{v_g\delta_A\delta_P}^{\psi}, N_{v_g\delta_A\delta_B}^{\phi}, N_{w_g\delta_B\delta_P}^{\psi}, N_{w_g\delta_A\delta_P}^{\psi}, N_{w_g\delta_A\delta_B}^{\phi}$ $N_{p_g\delta_B\delta_P}^{\psi}, N_{p_g\delta_A\delta_P}^{\psi}, N_{p_g\delta_A\delta_B}^{\phi}, N_{q_g\delta_B\delta_P}^{\psi}, N_{q_g\delta_A\delta_P}^{\psi}, N_{q_g\delta_A\delta_B}^{\phi}, N_{r_g\delta_B\delta_P}^{\psi}, N_{r_g\delta_A\delta_P}^{\psi}, N_{r_g\delta_A\delta_B}^{\phi}$ $N_{u_g\delta_A\delta_B}^{\psi}, N_{u_g\delta_A\delta_P}^{\psi}, N_{u_g\delta_B\delta_P}^{\psi}, N_{u_g\delta_A\delta_B}^{\phi}, N_{u_g\delta_A\delta_P}^{\phi}, N_{u_g\delta_B\delta_P}^{\phi}, N_{v_g\delta_A\delta_B}^{\psi}, N_{v_g\delta_A\delta_P}^{\psi}, N_{v_g\delta_B\delta_P}^{\psi}$ $N_{w_g\delta_A\delta_B}^{\psi}, N_{w_g\delta_A\delta_P}^{\psi}, N_{w_g\delta_B\delta_P}^{\psi}, N_{w_g\delta_A\delta_B}^{\phi}, N_{w_g\delta_A\delta_P}^{\phi}, N_{w_g\delta_B\delta_P}^{\phi}, N_{u_g\delta_C\delta_A}^{\psi}, N_{u_g\delta_C\delta_B}^{\psi}, N_{u_g\delta_C\delta_A}^{\phi}$ $N_{v_g\delta_C\delta_A}^{\psi}, N_{v_g\delta_C\delta_B}^{\psi}, N_{v_g\delta_C\delta_P}^{\psi}$
Type III	$N_{u_g\delta_A\delta_B\delta_P}^{\psi}, N_{u_g\delta_A\delta_B\delta_P}^{\phi}, N_{v_g\delta_A\delta_B\delta_P}^{\psi}, N_{w_g\delta_A\delta_B\delta_P}^{\psi}, N_{w_g\delta_A\delta_B\delta_P}^{\phi}, N_{u_g\delta_C\delta_A\delta_B}^{\psi}, N_{v_g\delta_C\delta_A\delta_B}^{\psi}$ $N_{v_g\delta_C\delta_A\delta_B}^{\phi}, N_{v_g\delta_C\delta_A\delta_P}^{\psi}, N_{w_g\delta_C\delta_A\delta_B}^{\phi}$
Type IV	$N_{u_g\delta_C\delta_A\delta_B\delta_P}^{\psi}, N_{v_g\delta_C\delta_A\delta_B\delta_P}^{\psi}, N_{w_g\delta_C\delta_A\delta_B\delta_P}^{\psi}$

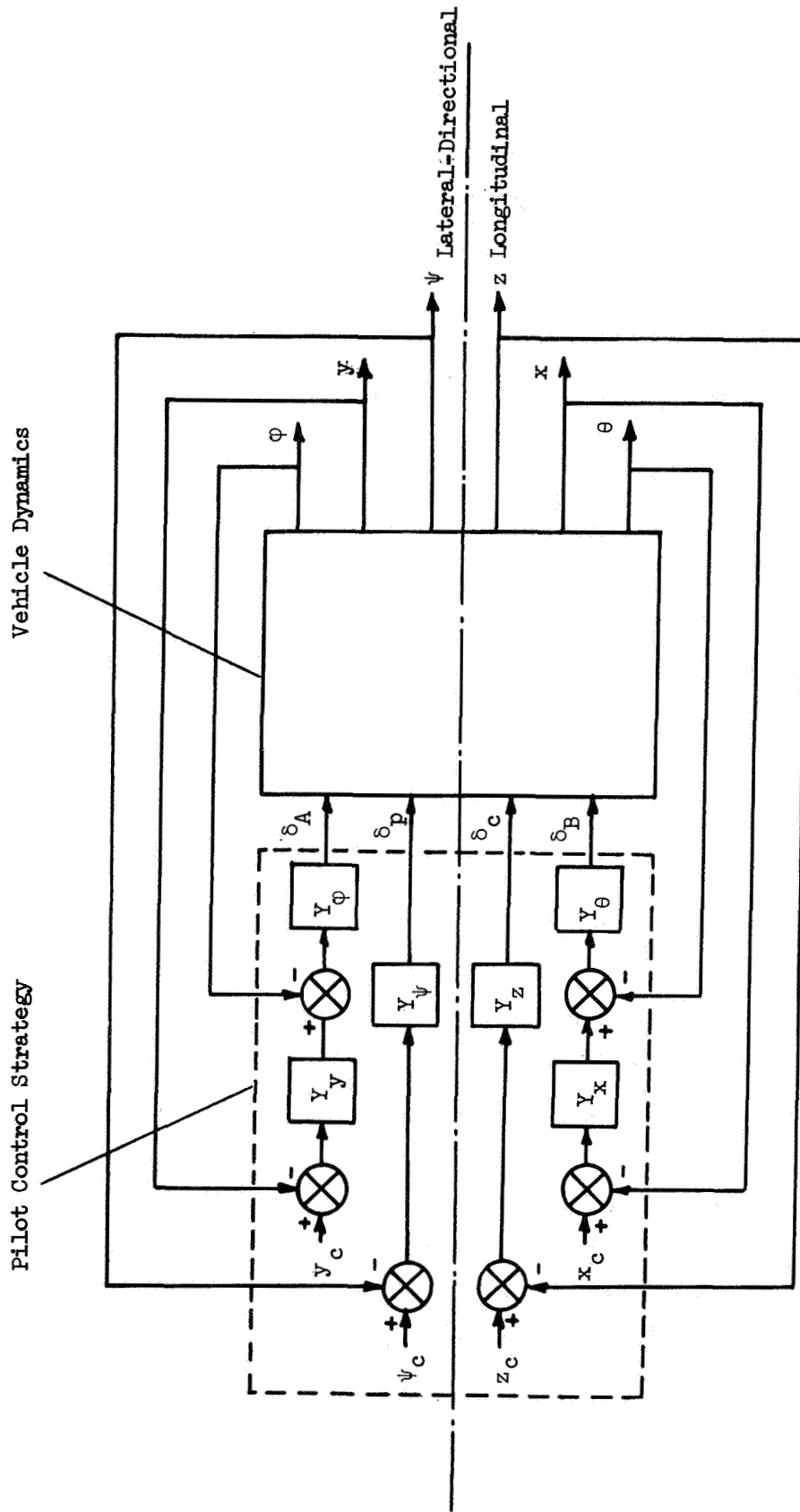

Figure I-1. Assumed Pilot-Vehicle Loop Structure for Low Speed Flight

TABLE I-6

THE ABBREVIATED LIST OF CONTROL NUMERATORS

Type 0	$N_{\delta_A}^{\psi}, N_{\delta_B}^{\psi}, N_{\delta_p}^{\psi}, N_{\delta_B}^{\psi}, N_{\delta_A}^{\psi}$
Type I	$N_{\delta_A \delta_B}^{\psi}, N_{\delta_A \delta_p}^{\psi}, N_{\delta_B \delta_p}^{\psi}, N_{\delta_B \delta_p}^{\psi}, N_{\delta_p \delta_B}^{\psi}, N_{\delta_c \delta_B}^{\psi}, N_{\delta_A \delta_p}^{\psi}, N_{\delta_p \delta_A}^{\psi}, N_{\delta_c \delta_A}^{\psi}, N_{\delta_A \delta_B}^{\psi}, N_{\delta_B \delta_A}^{\psi}$ $N_{\delta_B \delta_A}^{\psi}, N_{\delta_A \delta_B}^{\psi}, N_{\delta_c \delta_A}^{\psi}, N_{\delta_c \delta_A}^{\psi}, N_{\delta_p \delta_B}^{\psi}, N_{\delta_B \delta_A}^{\psi}$
Type II	$N_{\delta_A \delta_B \delta_p}^{\psi}, N_{\delta_c \delta_B \delta_p}^{\psi}, N_{\delta_c \delta_A \delta_p}^{\psi}, N_{\delta_c \delta_A \delta_B}^{\psi}$ $N_{\delta_B \delta_A \delta_p}^{\psi}, N_{\delta_A \delta_B \delta_p}^{\psi}, N_{\delta_c \delta_A \delta_B}^{\psi}, N_{\delta_c \delta_A \delta_p}^{\psi}, N_{\delta_c \delta_A \delta_B}^{\psi}, N_{\delta_c \delta_A \delta_p}^{\psi}, N_{\delta_p \delta_A \delta_B}^{\psi}, N_{\delta_B \delta_A \delta_p}^{\psi}$
Type III	$N_{\delta_c \delta_A \delta_B \delta_p}^{\psi}, N_{\delta_c \delta_A \delta_B \delta_p}^{\psi}$

The high frequency gain in the denominator is always unity, hence is not indicated. The low frequency gain is enclosed in angle brackets at the end of the line. In the above denominator the low frequency gain is .569 (i.e., $.0636 \times 5.72 \times .287^2 \times 1.66^2 \times 2.63^2$).

A numerator is described as above except that it also has a descriptor and non-unity high frequency gain. For example, consider the ϕ/δ_A control numerator:

CONTROL NUMERATORS:

PHI/DA 1.26 (0) (1.39) (1.86) [.0518;.303][.268;2.59]<2.00>

The descriptor, "PHI/DA" in this case, corresponds to the numerator superscript and subscript combination, i.e.,

$$N_{\delta_A}^{\phi}$$

The high frequency gain immediately follows, thus:

$$N_{\delta_A}^{\phi} = 1.26s(s+1.39)(s+1.86)[s^2+2 \times .0518 \times .303s+.303^2] \\ [s^2+2 \times .268 \times 2.59s+2.59^2]$$

The low frequency gain in the above case is 2.00, i.e., $1.26 \times 1.39 \times 1.86 \times .303^2 \times 2.59^2$.

Coupling numerators of higher type are denoted in the same manner except the descriptor contains more elements. The Type I numerator, $N_{\delta_A \delta_B}^{\phi \theta}$ is:

PHI/DA ;THE/DB -.941 (0) (.0218) (.743)[.269;2.66]<-.108>

The Type II numerator, $N_{\delta_c \delta_A \delta_B}^{\psi \phi \theta}$ is:

PSI/DC ;PHI/DA ;THE/DB -.459 (.0209) (.0615) (1.04)<-.000611>

and the Type III numerator, $N_{\delta_c \delta_A \delta_B \delta_p}^{\dot{x} \phi \theta \psi}$ is:

X D/DC ; PHI/DA ; THE/DB ; PSI/DP .414 (-.0246) (.778) <-.00792>

A brief explanation of higher type numerators is given in Appendix B. For a more complete treatment of the subject the reader is referred to Section 3-5 of Ref. 2.

The units of transfer function quantities are:

Radians for ϕ , θ , and ψ

Feet/second for \dot{x} , \dot{y} , and \dot{z}

Inches for δ_c , δ_B , δ_A , and δ_p .

The units of all factored roots are radians/second.

SECTION II
HUGHES OH-6A

The Hughes OH-6A is a single-turbine, light observation helicopter which has a gross weight of 1225 kg (2700 lb) and seats two pilots plus two passengers. The rotor system consists of a four-bladed, fully articulated main rotor and is powered by a 317 shp Lycoming T63-A-5A turboshaft engine derated to 252.5 shp for takeoff*.

The control system is purely mechanical employing no hydraulic actuation devices. Hence, the control system is reversible with rotor hinge moments fed back to the pilot's controls, however, this aspect is not modeled here. All derivative and transfer function data are for constrained cockpit control deflections (i.e., controls-fixed). Significant control system flexibility effects are also a factor and are included in the data presented as constant control-attenuation coefficients.

Reference 3 is the main source of OH-6A data and contains basic geometric, aerodynamic, and control system descriptions. Rotor system drive characteristics are also given but are not incorporated in the basic data. The stability and control derivatives presented in Ref. 3 were estimated using the manufacturer's helicopter simulation derivative program, SIM8DF. Derivatives for all the flight conditions presented in Ref. 3 have been transcribed to this compilation. Miscellaneous additional information from Refs. 7 and 8 have been added to complete the descriptive data on this page and in Table II-1.

* Ref. 7.

Preceding page blank

PRECEDING PAGE BLANK NOT FILMED

TABLE II-1
OH-6A DESCRIPTIVE DATA

MAIN ROTOR

Blades 4
 Radius 4.013 m (13.167 ft)
 Chord 0.171 m (0.5625 ft)
 Section NACA 0015
 Hub type Articulated
 Twist -8 deg
 Pitch flap coupling (δ_3) Zero
 Shaft tilt 3 deg forward
 Design rpm 465 to 483 (power on), 400 to 514 (power off)*
 Hub location FS 100, WL 83†
 Blade flapping inertia 63.49 kg-m² (46.83 slug-ft²)

TAIL ROTOR

Blades 2
 Radius 0.648 m (2.125 ft)
 Chord 0.12 m (0.40 ft)
 Twist -8.0 deg
 Gear ratio 6.447
 Hub location FS 282, WL 54.3, BL -11.6

HORIZONTAL STABILIZER

Area 0.678 m² (7.30 ft²)
 Aspect ratio 3.84
 Center of pressure location FS 280.3, WL 65., BL 28.82
 Dihedral 25 deg
 Incidence 0.8 deg

UPPER VERTICAL STABILIZER

Area 0.328 m² (3.53 ft²)
 Aspect ratio 4.35
 Center of pressure location FS 288, WL 75

LOWER VERTICAL STABILIZER

Area 0.139 m² (1.5 ft²)
 Aspect ratio 2.67
 Center of pressure location FS 283, WL 42

* From Ref. 8
 † Manufacturer's fuselage reference system as shown in Fig. II-1.

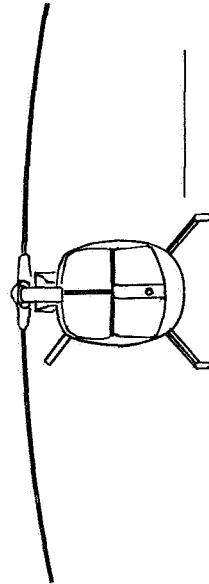
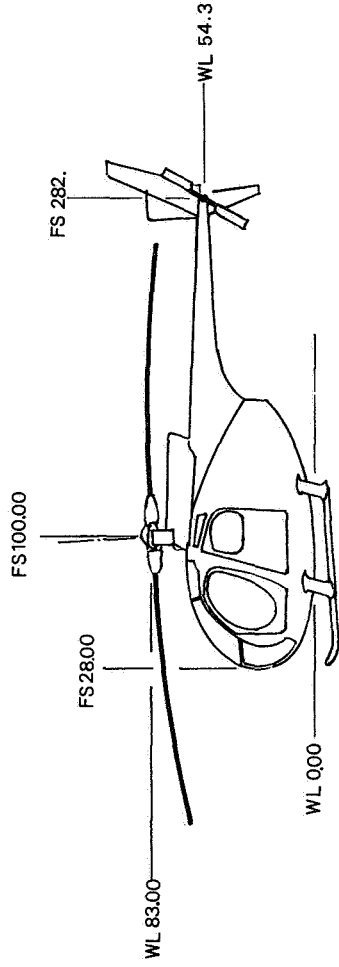
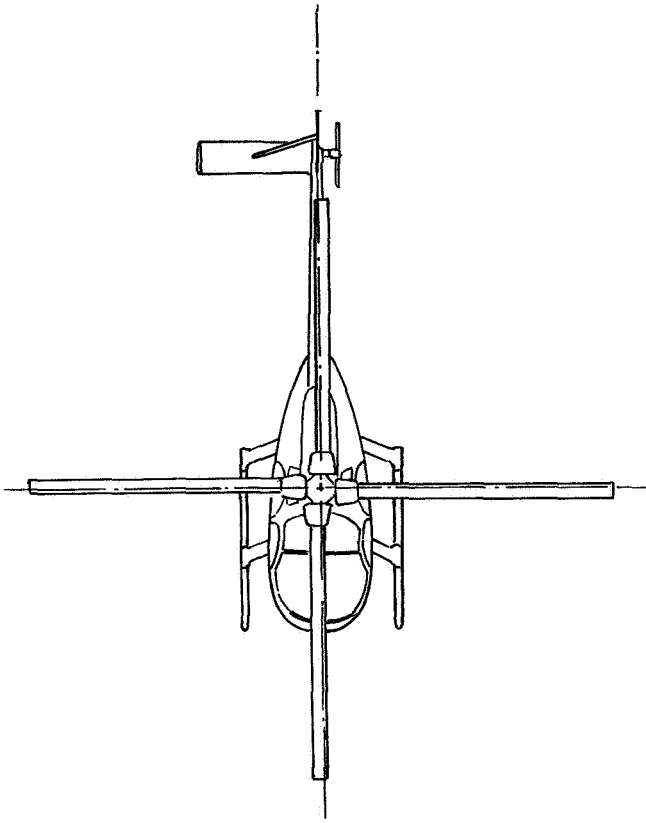
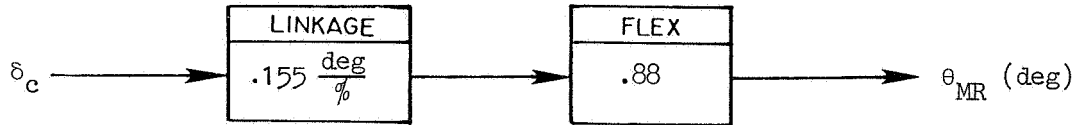

Figure II-1. General Arrangement

a. Block Diagram

COLLECTIVE



- All cockpit control deflections shown in this diagram have units of $\frac{1}{4}$ full travel.

PITCH

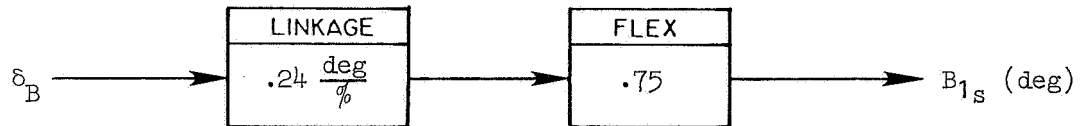

- Full scale wind tunnel tests have shown that flexibility in the control system reduces commanded blade angles. This reduction is approximated by the flexibility constants shown in the respective control-to-blade angle block diagrams.

ROLL

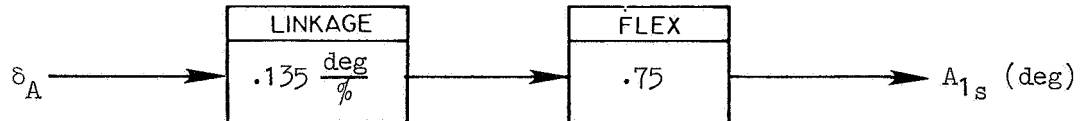

YAW

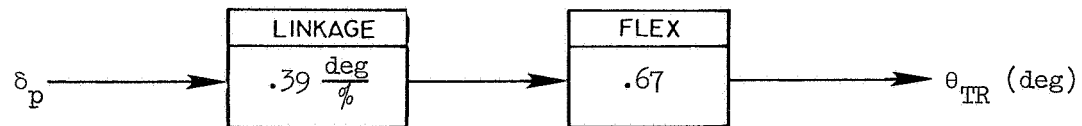

Figure II-2. OH-6A Control System Description

b. Cockpit Controller Characteristics

CONTROLLER	100% FULL TRAVEL cm (in)
Collective, δ_c	22.9 (9)
Longitudinal Cyclic, δ_B	31.8 (12.5)
Lateral Cyclic, δ_A	29.2 (11.5)
Pedal, δ_P	9.3 (3.65)

Figure II-2 (Concluded)

a. Loading Envelope

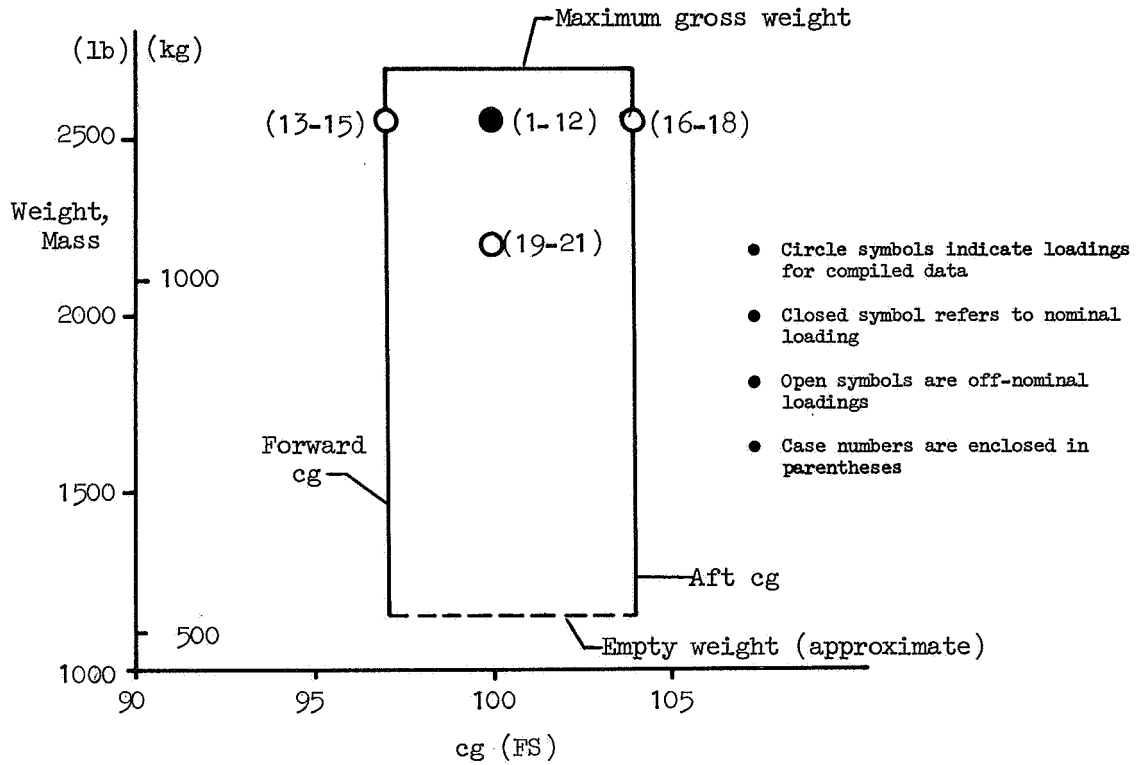

b. Moments of Inertia for Compiled Data

CONDITION	MASS (WEIGHT) kg (lb)	CG		I_x	I_y	I_z	I_{xz}
		FS	WL				
Nominal Weight	1157(2550)	97 to 104	49.6	446(329)	1219(899)	979(722)	128(94.5)
Light Weight	998(2200)	97 to 104	49.6	415(306)	1186(875)	934(689)	127(94.0)

Figure II-3. OH-6A Loading Summary

TABLE II-2

OH-6A INDEX OF FLIGHT CONDITIONS
FOR DERIVATIVES AND TRANSFER FUNCTION FACTORS

CASE	CONDITION	AIRSPEED kt	VERTICAL VELOCITY m/sec (ft/sec)	ALTITUDE m (ft)	MASS (WEIGHT) kg (lb)	cg FS	REPORT PAGE NUMBER	
							DERIVATIVES SI (US)	TRANSFER FUNCTIONS
1	Airspeed Variation	-40	Zero	Sea Level	1157 (2550)	100	26 (35)	44
2		-30						
3		-20						
4		Hover					27 (36)	45
5		20						
6		30						
7		40						
8		60					28 (37)	5-55*
9		80						
10		100						
11		120					29 (38)	50
12		130						
13		130						
13	Forward cg	Hover				97	30 (39)	
14		100						
15		130						
16	Aft cg	Hover				104	31 (40)	
17		100						
18		130						
19	Light Weight	Hover			998 (2200)	100	32 (41)	63
20		100						
21		130						
22	Operation at Altitude	Hover		1524 (5000)	1157 (2550)		33 (42)	
23		100						
24		130						
25	Maximum Power Climb	60		Sea Level			34 (43)	64
26		60		Sea Level				

* Extended list of transfer function factors.

TABLE 11-3
OH-6A STABILITY AND CONTROL DERIVATIVES -- SI UNITS
(BODY-FIXED FRL AXIS SYSTEM)

CASE	1	-40 KT		LEVEL FLIGHT AT SEA LEVEL			1157 KG	MID CG		
	PHI	THETA	PSI	ALPHA	BETA	GAMMA	ΘMR	B1S	A1S	ΘTR
	-2.03	3.76	0.00	-176.24	0.13	180.00	12.92	-2.58	-0.01	12.43
	XDOT	ZDOT	UO	VO	WO	VT0				
	-20.58	0.00	-20.53	0.05	-1.35	20.58				
	U	W	Q	V	P	R	DC	DB	DA	DP
X	-0.0439	0.0251	0.5530	0.0001	-0.2325	-0.0044	0.0665	0.1115	-0.0040	1.0064
Z	0.1559	-0.6323	-0.0692	-0.0177	0.1166	0.4127	-0.9085	-0.1265	-0.0025	-0.0045
H	0.0459	-0.1590	-2.2755	-0.0378	0.2764	0.2079	-0.1207	-0.3036	0.0143	-0.0123
Y	-0.0069	0.0080	-0.1890	-0.0678	-0.5240	0.1553	-0.0020	0.0091	0.0630	0.1881
L'	0.0036	-0.0617	-1.2755	-0.1425	-5.3893	-0.2253	0.0097	0.0597	0.4956	-0.0302
H'	0.0620	-0.1573	-0.8046	0.2339	-1.1928	-1.1483	0.2306	-0.0207	0.0655	-1.0293
CASE	2	-30 KT		LEVEL FLIGHT AT SEA LEVEL			1157 KG	MID CG		
	PHI	THETA	PSI	ALPHA	BETA	GAMMA	ΘMR	B1S	A1S	ΘTR
	-2.24	2.96	0.00	-177.04	0.12	180.00	13.24	-2.34	-0.03	13.72
	XDOT	ZDOT	UO	VO	WO	VT0				
	-15.43	0.00	-15.41	0.03	-0.80	15.43				
	U	W	Q	V	P	R	DC	DB	DA	DP
X	-0.0397	0.0173	0.5150	0.0002	-0.2377	-0.0078	0.0526	0.1078	-0.0043	0.0052
Z	0.1980	-0.5453	0.0449	-0.0232	0.1602	0.4815	-0.8591	-0.0891	0.0084	-0.0037
H	0.0514	-0.1172	-2.1514	-0.0276	0.2999	0.1740	-0.0903	-0.2972	0.0144	-0.0069
Y	-0.0060	0.0049	-0.2038	-0.0566	-0.4961	0.1351	-0.0016	0.0094	0.0628	0.1796
L'	0.0089	-0.0455	-1.2462	-0.1430	-5.2968	-0.2487	0.0251	0.0703	0.4954	-0.0281
H'	0.0582	-0.1096	-0.6168	0.1692	-1.1801	-1.0321	0.2620	-0.0109	0.0664	-0.9832
CASE	3	-20 KT		LEVEL FLIGHT AT SEA LEVEL			1157 KG	MID CG		
	PHI	THETA	PSI	ALPHA	BETA	GAMMA	ΘMR	B1S	A1S	ΘTR
	-2.58	2.39	0.00	-177.62	0.11	180.00	13.85	-2.04	-0.10	15.43
	XDOT	ZDOT	UO	VO	WO	VT0				
	-10.29	0.00	-10.28	0.02	-0.43	10.29				
	U	W	Q	V	P	R	DC	DB	DA	DP
X	-0.0346	0.0109	0.4647	0.0019	-0.2435	-0.0036	0.0431	0.1058	-0.0039	0.0043
Z	0.1984	-0.4344	-0.0392	-0.0492	0.0332	0.3121	-0.8618	-0.0746	-0.0056	-0.0029
H	0.0502	-0.0787	-2.0047	-0.0184	0.3334	0.1543	-0.0678	-0.2927	0.0152	-0.0003
Y	-0.0045	0.0055	-0.2108	-0.0467	-0.4466	0.1450	-0.0011	0.0101	0.0641	0.1987
L'	0.0095	-0.0300	-1.1905	-0.1414	-5.1219	-0.2111	0.0178	0.0768	0.5018	-0.0306
H'	0.0438	-0.0780	-0.5092	0.1095	-1.2004	-1.0663	0.2952	-0.0099	0.0630	-1.0879

TABLE II-3 CONTINUED
OH-6A STABILITY AND CONTROL DERIVATIVES -- SI UNITS
(BODY-FIXED FRL AXIS SYSTEM)

CASE	0 KT		LEVEL FLIGHT AT SEA LEVEL			1157 KG	MID CG			
	PHI	THETA	PSI	ALPHA	BETA	GAMMA	ΘMR	B1S	A1S	ΘTR
	-3.05	1.66	0.00	1.65	-0.09	0.00	14.70	-1.21	-0.22	17.33
	XDOT		ZDOT	U0	V0	W0	VT0			
	0.00		0.00	0.00	0.00	0.00	0.00			
	U	W	Q	Y	P	R	DC	DB	DA	DP
X	-0.0257	0.0113	0.3972	0.0004	-0.2494	-0.0185	0.0260	0.1032	-0.0034	-0.0039
Z	-0.0422	-0.3404	0.0050	-0.0440	0.0177	0.4495	-0.9812	-0.0019	0.0013	-0.0046
H	0.0414	-0.0196	-1.7645	-0.0086	0.3763	0.0719	-0.0309	-0.2916	0.0138	-0.0038
Y	0.0158	-0.0194	-0.2573	-0.0435	-0.4104	0.1045	-0.0069	0.0046	0.0617	0.1841
L'	0.0010	-0.0064	-1.1360	-0.1516	-4.9198	-0.2873	0.0475	0.0738	0.5037	-0.0308
M'	-0.0861	0.1018	-0.1724	-0.0054	-1.0748	-0.8645	0.3743	0.0194	0.0780	-1.0109
CASE	20 KT		LEVEL FLIGHT AT SEA LEVEL			1157 KG	MID CG			
	PHI	THETA	PSI	ALPHA	BETA	GAMMA	ΘMR	B1S	A1S	ΘTR
	-2.45	1.52	0.00	1.52	-0.06	0.00	13.84	-0.03	-0.36	14.63
	XDOT		ZDOT	U0	V0	W0	VT0			
	10.29		0.00	10.29	-0.01	0.27	10.29			
	U	W	Q	Y	P	R	DC	DB	DA	DP
X	-0.0167	0.0216	0.4624	0.0024	-0.2375	-0.0301	0.0108	0.0996	-0.0001	-0.0060
Z	-0.1896	-0.4337	0.0483	-0.0370	-0.0006	0.4654	-0.8384	0.0841	0.0125	-0.0002
H	0.0511	-0.0099	-1.8793	-0.0061	0.3497	0.0954	0.0226	-0.2900	0.0140	0.0108
Y	0.0080	-0.0061	-0.2430	-0.0490	-0.4814	0.1474	-0.0011	0.0073	0.0625	0.1865
L'	0.0018	-0.0224	-1.1404	-0.1461	-5.1712	-0.2623	0.0520	0.0711	0.4992	-0.0276
M'	-0.0702	-0.0249	-0.1569	0.0825	-1.1071	-1.1038	0.2934	0.0138	0.0699	-1.0245
CASE	30 KT		LEVEL FLIGHT AT SEA LEVEL			1157 KG	MID CG			
	PHI	THETA	PSI	ALPHA	BETA	GAMMA	ΘMR	B1S	A1S	ΘTR
	-2.00	1.68	0.00	1.68	-0.06	0.00	13.18	0.53	-0.41	12.54
	XDOT		ZDOT	U0	V0	W0	VT0			
	15.43		0.00	15.43	-0.02	0.45	15.43			
	U	W	Q	Y	P	R	DC	DB	DA	DP
X	-0.0204	0.0180	0.5056	0.0038	-0.2125	-0.0516	0.0028	0.0983	-0.0043	-0.0055
Z	-0.1420	-0.5473	-0.0650	-0.0313	-0.0783	0.3827	-0.9753	0.1034	0.0025	0.0013
H	0.0537	-0.0019	-2.0215	-0.0147	0.3529	0.0924	0.0243	-0.2860	0.0154	0.0146
Y	0.0054	-0.0103	-0.2555	-0.0581	-0.5404	0.1439	-0.0058	0.0055	0.0605	0.1650
L'	0.0002	-0.0162	-1.1554	-0.1462	-5.3030	-0.2649	0.0420	0.0770	0.4993	-0.0235
M'	-0.0576	-0.0440	-0.0275	0.1251	-1.0852	-1.0691	0.2794	0.0329	0.0782	-0.9061

TABLE II-3 CONTINUED
OH-6A STABILITY AND CONTROL DERIVATIVES -- SI UNITS
(BODY-FIXED FRL AXIS SYSTEM)

CASE	40 KT		LEVEL FLIGHT AT SEA LEVEL			1157 KG	MID CG			
	PHI	THETA	PSI	ALPHA	BETA	GAMMA	ΘNR	B1S	A1S	ΘTR
7	-1.74	1.48	0.00	1.48	-0.04	0.00	12.79	0.96	-0.43	11.25
	XDOT	ZDOT	U0	V0	W0	VT0				
	20.58	0.00	20.57	-0.02	0.53	20.58				
	U	W	Q	V	P	R	DC	DB	DA	DP
X	-0.0270	0.0125	0.5189	0.0008	-0.2285	-0.0169	0.0058	0.0957	-0.0046	-0.0058
Z	-0.0941	-0.6299	-0.1564	-0.0234	-0.1242	0.4415	-0.9069	0.1348	0.0058	0.0022
M	0.0426	-0.0113	-2.2421	-0.0356	0.2852	0.1843	0.0621	-0.2878	0.0152	0.0168
Y	0.0041	-0.0120	-0.2720	-0.0679	-0.5880	0.1457	-0.0037	0.0055	0.0602	0.1613
L'	-0.0063	-0.0571	-1.2325	-0.1571	-5.4483	-0.2164	0.0497	0.0771	0.4976	-0.0224
N'	-0.0468	-0.0712	0.1582	0.1654	-1.0122	-1.1024	0.2285	0.0436	0.0785	-0.8862
CASE	60 KT		LEVEL FLIGHT AT SEA LEVEL			1157 KG	MID CG			
	PHI	THETA	PSI	ALPHA	BETA	GAMMA	ΘNR	B1S	A1S	ΘTR
8	-1.54	0.58	0.00	0.58	-0.02	0.00	12.59	1.79	-0.48	10.08
	XDOT	ZDOT	U0	V0	W0	VT0				
	30.87	0.00	30.87	-0.01	0.31	30.87				
	U	W	Q	V	P	R	DC	DB	DA	DP
X	-0.0314	0.0107	0.5506	0.0015	-0.2234	-0.0156	-0.0057	0.0930	-0.0044	-0.0072
Z	-0.0371	-0.7150	-0.2152	-0.0210	-0.2914	0.4056	-0.9955	0.2211	0.0032	0.0052
M	0.0345	-0.0130	-2.4843	-0.0611	0.2077	0.2636	0.1083	-0.2938	0.0144	0.0314
Y	0.0009	-0.0186	-0.3047	-0.0836	-0.5919	0.2062	-0.0039	0.0062	0.0602	0.1912
L'	-0.0083	-0.0844	-1.3056	-0.1642	-5.4853	-0.1582	0.0477	0.0729	0.4941	-0.0323
N'	-0.0240	-0.0800	0.5060	0.2120	-1.1022	-1.4412	0.1822	0.0566	0.0741	-1.0514
CASE	80 KT		LEVEL FLIGHT AT SEA LEVEL			1157 KG	MID CG			
	PHI	THETA	PSI	ALPHA	BETA	GAMMA	ΘNR	B1S	A1S	ΘTR
9	-1.60	-0.77	0.00	-0.77	0.02	0.00	13.02	2.57	-0.60	9.85
	XDOT	ZDOT	U0	V0	W0	VT0				
	41.16	0.00	41.15	0.02	-0.55	41.16				
	U	W	Q	V	P	R	DC	DB	DA	DP
X	-0.0379	0.0064	0.5333	0.0011	-0.2203	-0.0195	-0.0210	0.0899	-0.0049	-0.0113
Z	-0.0126	-0.7655	-0.2194	-0.0249	-0.3605	0.4658	-1.0715	0.3185	0.0033	0.0054
M	0.0348	-0.0086	-2.6776	-0.0746	0.2004	0.3948	0.1571	-0.2969	0.0163	0.0285
Y	0.0018	-0.0218	-0.2811	-0.0994	-0.5972	0.2841	-0.0035	0.0098	0.0621	0.2149
L'	-0.0036	-0.1039	-1.3420	-0.1774	-5.4942	-0.0739	0.0560	0.0790	0.4982	-0.0276
N'	-0.0239	-0.0907	0.5444	0.2508	-0.9747	-1.4327	0.1657	0.0553	0.0646	-1.1815

TABLE 11-3 CONTINUED
OH-6A STABILITY AND CONTROL DERIVATIVES -- SI UNITS
(BODY-FIXED FRL AXIS SYSTEM)

CASE	100 KT		LEVEL FLIGHT AT SEA LEVEL			1157 KG	MID CG			
	PHI	THETA	PSI	ALPHA	BETA	GAMMA	ΘMR	B1S	A1S	ΘTR
	-1.88	-2.14	0.00	-2.14	0.07	0.00	14.03	3.89	-0.86	10.18
		IDOT	ZDOT	U0	V0	W0	VT0			
		51.44	0.00	51.41	0.06	-1.92	51.44			
	U	W	Q	V	P	R	DC	DB	DA	DP
X	-0.0437	0.0081	0.4829	0.0015	-0.2237	-0.0157	-0.0263	0.0880	-0.0041	-0.0148
Z	0.0023	-0.7977	-0.2723	-0.0374	-0.4821	0.4861	-1.1383	0.4017	0.0005	0.0110
H	0.0344	-0.0093	-2.3275	-0.0979	0.1469	0.4617	0.1964	-0.3057	0.0155	0.0584
Y	0.0021	-0.0325	-0.3635	-0.1174	-0.5489	0.3137	-0.0121	0.0080	0.0611	0.2196
L*	-0.0029	-0.1238	-1.4309	-0.2024	-5.2565	-0.0058	0.0560	0.0765	0.5005	-0.0416
M*	-0.0243	-0.0125	1.0475	0.2926	-0.9802	-2.0187	0.2357	0.0676	0.0730	-1.2102
CASE	120 KT		LEVEL FLIGHT AT SEA LEVEL			1157 KG	MID CG			
	PHI	THETA	PSI	ALPHA	BETA	GAMMA	ΘMR	B1S	A1S	ΘTR
	-2.34	-3.94	0.00	-3.94	0.16	0.00	15.64	5.41	-1.32	10.81
		IDOT	ZDOT	U0	V0	W0	VT0			
		61.73	0.00	61.59	0.17	-4.24	61.73			
	U	W	Q	V	P	R	DC	DB	DA	DP
X	-0.0536	0.0075	0.3698	0.0003	-0.2433	-0.0227	-0.0346	0.0850	-0.0041	-0.0260
Z	0.0127	-0.8050	-0.2307	-0.0444	-0.5336	0.5800	-1.1526	0.4907	0.0039	0.0104
H	0.0430	-0.0045	-2.9488	-0.1078	0.1673	0.5662	0.2473	-0.3147	0.0168	0.0511
Y	0.0026	-0.0421	-0.3244	-0.1344	-0.4936	0.3848	-0.0245	0.0123	0.0628	0.2360
L*	0.0010	-0.1494	-1.5519	-0.2348	-5.0022	0.0595	0.0479	0.0747	0.5054	-0.0281
M*	-0.0247	0.0700	0.7900	0.3239	-0.8117	-2.4360	0.3615	0.0332	0.0711	-1.3019
CASE	130 KT		LEVEL FLIGHT AT SEA LEVEL			1157 KG	MID CG			
	PHI	THETA	PSI	ALPHA	BETA	GAMMA	ΘMR	B1S	A1S	ΘTR
	-2.66	-4.80	0.00	-4.80	0.22	0.00	16.70	6.48	-1.61	11.46
		IDOT	ZDOT	U0	V0	W0	VT0			
		66.88	0.00	66.64	0.26	-5.59	66.88			
	U	W	Q	V	P	R	DC	DB	DA	DP
X	-0.0570	0.0138	0.2905	0.0001	-0.2578	-0.0240	-0.0353	0.0827	-0.0041	-0.0317
Z	0.0178	-0.8096	-0.3092	-0.0485	-0.5825	0.6244	-1.1667	0.5212	0.0043	0.0141
H	0.0498	-0.0065	-2.9912	-0.1163	0.1693	0.6034	0.2652	-0.3239	0.0172	0.0662
Y	0.0036	-0.0488	-0.3196	-0.1438	-0.4203	0.4176	-0.0340	0.0163	0.0640	0.2320
L*	0.0047	-0.1655	-1.6260	-0.2542	-4.8062	0.0913	0.0359	0.0698	0.5089	-0.0257
M*	-0.0301	0.1340	0.6085	0.3403	-0.8152	-2.6430	0.4704	-0.0113	0.0706	-1.2815

TABLE 11-3 CONTINUED
OH-6A STABILITY AND CONTROL DERIVATIVES-- SI UNITS
(BODY-FIXED FRL AXIS SYSTEM)

CASE	0 KT		LEVEL FLIGHT AT SEA LEVEL				1157 KG	FWD CG		
	PHI	THETA	PSI	ALPHA	BETA	GAMMA	θMR	B1S	A1S	θTR
13	-3.05	0.20	0.00	0.20	-0.01	0.00	14.70	-2.58	-0.10	17.16
	IDOT	ZDOT	U0	V0	W0	VTO				
	0.00	0.00	0.00	0.00	0.00	0.00				
	U	W	Q	V	P	R	DC	DB	DA	DP
X	-0.0267	0.0036	0.3974	-0.0008	-0.2507	-0.0060	0.0030	0.1028	-0.0035	-0.0035
Z	-0.0555	-0.3449	0.0005	-0.0457	0.0672	0.4865	-0.8749	0.0039	0.0056	-0.0045
M	0.0387	-0.0358	-1.7601	-0.0103	0.3867	0.0866	-0.0655	-0.2901	0.0145	-0.0041
Y	0.0156	-0.0197	-0.2599	-0.0437	-0.4110	0.1063	-0.0072	0.0042	0.0616	0.1822
L*	-0.0004	-0.0079	-1.0767	-0.1518	-4.8978	-0.2795	0.0476	0.0721	0.5024	-0.0353
N*	-0.0887	0.1026	0.2259	-0.0027	-1.0287	-0.8760	0.3758	0.0200	0.0735	-1.0176

CASE	100 KT		LEVEL FLIGHT AT SEA LEVEL				1157 KG	FWD CG		
	PHI	THETA	PSI	ALPHA	BETA	GAMMA	θMR	B1S	A1S	θTR
14	-1.78	-3.54	0.00	-3.54	0.11	0.00	14.05	2.54	-0.84	9.80
	IDOT	ZDOT	U0	V0	W0	VTO				
	51.44	0.00	51.35	0.10	-3.18	51.44				
	U	W	Q	V	P	R	DC	DB	DA	DP
X	-0.0439	-0.0095	0.4713	0.0004	-0.2325	0.0004	-0.0532	0.0986	-0.0036	-0.0161
Z	-0.0160	-0.7995	-0.3371	-0.0369	-0.4688	0.4898	-1.1408	0.3967	-0.0010	0.0061
M	0.0349	-0.0478	-2.8644	-0.0958	0.1390	0.4761	0.1434	-0.2918	0.0132	0.0307
Y	0.0015	-0.0328	-0.3100	-0.1173	-0.5733	0.3351	-0.0137	0.0097	0.0616	0.2283
L*	-0.0051	-0.1357	-1.4157	-0.2060	-5.2860	-0.0495	0.0405	0.0700	0.4942	-0.0363
N*	-0.0266	-0.0204	1.1367	0.2999	-0.8335	-2.1766	0.2317	0.0599	0.0641	-1.2777

CASE	130 KT		LEVEL FLIGHT AT SEA LEVEL				1157 KG	FWD CG		
	PHI	THETA	PSI	ALPHA	BETA	GAMMA	θMR	B1S	A1S	θTR
15	-2.60	-6.22	0.00	-6.22	0.28	0.00	16.96	5.56	-1.69	11.15
	IDOT	ZDOT	U0	V0	W0	VTO				
	66.88	0.00	66.48	0.33	-7.24	66.88				
	U	W	Q	V	P	R	DC	DB	DA	DP
X	-0.0585	0.0136	0.2750	-0.0012	-0.2710	-0.0078	-0.0542	0.0943	-0.0034	-0.0303
Z	0.0054	-0.8085	-0.3885	-0.0497	-0.5660	0.6421	-1.1625	0.5154	0.0041	0.0104
M	0.0555	-0.0503	-3.0149	-0.1177	0.1444	0.6368	0.2034	-0.3016	0.0164	0.0495
Y	0.0042	-0.0514	-0.3185	-0.1450	-0.4086	0.4199	-0.0369	0.0181	0.0648	0.2406
L*	0.0085	-0.1700	-1.5831	-0.2536	-4.7637	0.1953	0.0317	0.0754	0.5102	-0.0364
N*	-0.0363	0.1589	0.8704	0.3572	-0.7804	-2.7451	0.5083	-0.0176	0.0655	-1.3512

TABLE II-3 CONTINUED
OH-6A STABILITY AND CONTROL DERIVATIVES -- SI UNITS
(BODY-FIXED FRL AXIS SYSTEM)

CASE	16	0 KT	LEVEL FLIGHT AT SEA LEVEL				1157 KG	AFT CG			
	PHI	THETA	PSI	ALPHA	BETA	GAMMA	ΘHR	B1S	A1S	ΘTR	
	-3.08	3.60	0.00	3.59	-0.19	0.00	14.73	0.59	-0.38	17.46	
	XDOT	ZDOT	U0	V0	W0	VTO					
	0.00	0.00	0.00	0.00	0.00	0.00					
	U	W	Q	V	P	R	DC	DB	DA	DP	
X	-0.0258	0.0218	0.3940	0.0026	-0.2500	-0.0372	0.0560	0.1037	-0.0035	-0.0039	
Z	-0.0245	-0.3372	0.0380	-0.0587	-0.0204	0.4296	-0.8836	-0.0042	-0.0009	-0.0043	
H	0.0443	0.0003	-1.7584	-0.0051	0.3822	0.0681	0.0187	-0.2909	0.0145	-0.0018	
Y	0.0159	-0.0187	-0.2577	-0.0428	-0.4122	0.1009	-0.0066	0.0048	0.0620	0.1847	
L'	0.0020	-0.0048	-1.2357	-0.1531	-4.9471	-0.2927	0.0490	0.0740	0.5068	-0.0240	
N'	-0.0834	0.0998	-0.6967	-0.0158	-1.1246	-0.8418	0.3743	0.0198	0.0851	-0.9910	

CASE	17	100 KT	LEVEL FLIGHT AT SEA LEVEL				1157 KG	AFT CG			
	PHI	THETA	PSI	ALPHA	BETA	GAMMA	ΘHR	B1S	A1S	ΘTR	
	-1.97	-0.59	0.00	-0.59	0.02	0.00	13.96	5.33	-0.90	10.63	
	XDOT	ZDOT	U0	V0	W0	VTO					
	51.44	0.00	51.44	0.02	-0.53	51.44					
	U	W	Q	V	P	R	DC	DB	DA	DP	
X	-0.0447	0.0250	0.4700	0.0021	-0.2127	-0.0396	0.0026	0.0755	-0.0047	-0.0179	
Z	0.0215	-0.7961	-0.1874	-0.0351	-0.4834	0.4846	-1.1368	0.4066	0.0019	0.0081	
H	0.0296	0.0463	-2.7721	-0.0885	0.2130	0.4646	0.2733	-0.3280	0.0173	0.0398	
Y	0.0015	-0.0281	-0.3061	-0.1159	-0.5668	0.3143	-0.0097	0.0076	0.0611	0.2273	
L'	-0.0043	-0.1161	-1.5136	-0.2048	-5.2544	-0.0079	0.0657	0.0735	0.5020	-0.0204	
N'	-0.0173	-0.0296	0.2889	0.2720	-0.9133	-1.9918	0.2288	0.0628	0.0773	-1.2234	

CASE	18	130 KT	LEVEL FLIGHT AT SEA LEVEL				1157 KG	AFT CG			
	PHI	THETA	PSI	ALPHA	BETA	GAMMA	ΘHR	B1S	A1S	ΘTR	
	-2.85	-3.37	0.00	-3.37	0.17	0.00	16.69	7.94	-1.56	12.23	
	XDOT	ZDOT	U0	V0	W0	VTO					
	66.89	0.00	66.76	0.20	-3.93	66.89					
	U	W	Q	V	P	R	DC	DB	DA	DP	
X	-0.0606	0.0297	0.2914	0.0026	-0.2326	-0.0419	-0.0019	0.0674	-0.0038	-0.0291	
Z	0.0346	-0.8101	-0.2398	-0.0487	-0.6206	0.6003	-1.1709	0.5236	0.0034	0.0166	
H	0.0406	0.0470	-2.9547	-0.1139	0.1900	0.5635	0.3390	-0.3587	0.0157	0.0813	
Y	0.0040	-0.0453	-0.3109	-0.1423	-0.4090	0.4124	-0.0301	0.0146	0.0638	0.2319	
L'	0.0020	-0.1541	-1.7083	-0.2571	-4.7813	0.0845	0.0506	0.0621	0.5104	-0.0154	
N'	-0.0301	0.1257	0.1085	0.3174	-0.8628	-2.5713	0.4623	-0.0151	0.0765	-1.2512	

TABLE II-3 CONTINUED
OH-6A STABILITY AND CONTROL DERIVATIVES -- SI UNITS
(BODY-FIXED FRL AXIS SYSTEM)

CASE	0 KT		LEVEL FLIGHT AT SEA LEVEL				998 KG	MID CG		
	PHI	THETA	PSI	ALPHA	BETA	GAMMA	ΘHR	B1S	A1S	ΘTR
19	-3.01	1.77	0.00	1.76	-0.09	0.00	13.78	-1.13	-0.19	15.95
	XDOT	ZDOT	UO	VO	WO	VT0				
	0.00	0.00	0.00	0.00	0.00	0.00				
	U	W	Q	V	P	R	DC	DB	DA	DP
X	-0.0240	0.0137	0.3728	0.0012	-0.2506	-0.0199	0.0313	0.1032	-0.0031	-0.0046
Z	-0.0595	-0.3877	-0.0203	-0.0655	0.0004	0.4218	-1.0094	0.0022	-0.0018	-0.0038
M	0.0340	-0.0201	-1.7089	-0.0107	0.3481	0.0605	-0.0332	-0.2832	0.0131	-0.0011
Y	0.0165	-0.0210	-0.2611	-0.0432	-0.3902	0.1173	-0.0073	0.0034	0.0614	0.2143
L*	-0.0014	-0.0056	-1.1067	-0.1330	-5.0207	-0.2977	0.0537	0.0733	0.5128	-0.0460
M*	-0.0820	0.1046	-0.1862	-0.0014	-1.1131	-0.8438	0.3563	0.0223	0.0839	-1.0661
20	100 KT		LEVEL FLIGHT AT SEA LEVEL				998 KG	MID CG		
	PHI	THETA	PSI	ALPHA	BETA	GAMMA	ΘHR	B1S	A1S	ΘTR
	-2.06	-2.86	0.00	-2.86	0.10	0.00	13.46	3.48	-0.85	9.69
	XDOT	ZDOT	UO	VO	WO	VT0				
	51.44	0.00	51.38	0.09	-2.57	51.44				
	U	W	Q	V	P	R	DC	DB	DA	DP
X	-0.0483	0.0122	0.4187	0.0004	-0.2309	-0.0190	-0.0251	0.0834	-0.0045	-0.0181
Z	0.0093	-0.9375	-0.2807	-0.0375	-0.5157	0.5583	-1.3274	0.4720	0.0041	0.0066
M	0.0314	-0.0149	-2.7468	-0.0939	0.1533	0.4914	0.1927	-0.2931	0.0164	0.0303
Y	0.0023	-0.0340	-0.3251	-0.1313	-0.5492	0.3892	-0.0109	0.0081	0.0621	0.2648
L*	-0.0010	-0.1270	-1.4729	-0.1956	-5.3111	-0.0091	0.0641	0.0734	0.5116	-0.0499
M*	-0.0201	-0.0122	0.6236	0.3024	-0.9092	-2.1983	0.2065	0.0493	0.0749	-1.3199
21	130 KT		LEVEL FLIGHT AT SEA LEVEL				998 KG	MID CG		
	PHI	THETA	PSI	ALPHA	BETA	GAMMA	ΘHR	B1S	A1S	ΘTR
	-2.98	-6.01	0.00	-6.01	0.31	0.00	16.62	6.50	-1.74	10.72
	XDOT	ZDOT	UO	VO	WO	VT0				
	66.88	0.00	66.51	0.36	-7.00	66.88				
	U	W	Q	V	P	R	DC	DB	DA	DP
X	-0.0636	0.0176	0.1891	-0.0007	-0.2595	-0.0171	-0.0203	0.0759	-0.0029	-0.0317
Z	0.0261	-0.9657	-0.2664	-0.0596	-0.6830	0.6921	-1.4007	0.6150	0.0029	0.0118
M	0.0472	-0.0215	-2.8787	-0.1187	0.1118	0.6142	0.2425	-0.3084	0.0153	0.0485
Y	0.0049	-0.0551	-0.3779	-0.1646	-0.3841	0.4987	-0.0356	0.0131	0.0653	0.2781
L*	0.0089	-0.1604	-1.7526	-0.2542	-4.7659	0.1038	0.0611	0.0615	0.5249	-0.0499
M*	-0.0273	0.1624	0.5284	0.3627	-0.7973	-2.7341	0.4607	-0.0176	0.0789	-1.3902

TABLE 11-3 CONTINUED
OH-6A STABILITY AND CONTROL DERIVATIVES -- SI UNITS
(BODY-FIXED FRL AXIS SYSTEM)

CASE	22	0 KT	LEVEL FLIGHT	1524 M	1157 KG	MID CG				
	PHI	THETA	PSI	ALPHA	BETA	GAMMA	ΘHR	B1S	A1S	ΘTR
	-3.18	1.66	0.00	1.65	-0.09	0.00	15.75	-1.21	-0.22	18.99
	XDOT	ZDOT	U0	V0	W0	VT0				
	0.00	0.00	0.00	0.00	0.00	0.00				
	U	W	Q	V	P	R	DC	DB	DA	DP
X	-0.0272	0.0101	0.4634	0.0010	-0.2384	-0.0193	0.0227	0.1029	-0.0039	-0.0047
Z	-0.0334	-0.3001	0.0393	-0.0425	0.0942	0.4704	-0.7686	0.0055	0.0039	-0.0032
M	0.0455	-0.0176	-2.0493	-0.0094	0.3207	0.0798	-0.0270	-0.2910	0.0153	0.0048
Y	0.0140	-0.0182	-0.2391	-0.0432	-0.4701	0.0872	-0.0055	0.0063	0.0618	0.1631
L'	-0.0057	-0.0067	-0.9629	-0.1712	-5.7392	-0.3433	0.0420	0.0805	0.4981	-0.0267
M'	-0.0814	0.0912	-0.1537	-0.0200	-1.2085	-0.8117	0.3602	0.0158	0.0745	-0.8962

CASE	23	100 KT	LEVEL FLIGHT	1524 M	1157 KG	MID CG				
	PHI	THETA	PSI	ALPHA	BETA	GAMMA	ΘHR	B1S	A1S	ΘTR
	-1.84	-1.69	0.00	-1.69	0.05	0.00	14.77	4.18	-0.80	10.90
	XDOT	ZDOT	U0	V0	W0	VT0				
	51.44	0.00	51.42	0.05	-1.52	51.44				
	U	W	Q	V	P	R	DC	DB	DA	DP
X	-0.0417	0.0043	0.5501	0.0011	-0.2185	-0.0251	-0.0277	0.0908	-0.0054	-0.0165
Z	0.0027	-0.6574	-0.2025	-0.0261	-0.3337	0.4899	-0.9256	0.3428	0.0039	0.0068
M	0.0406	0.0100	-2.9885	-0.0783	0.1738	0.4456	0.2063	-0.3054	0.0203	0.0345
Y	0.0010	-0.0291	-0.2665	-0.1038	-0.6239	0.2758	-0.0157	0.0101	0.0607	0.1971
L'	-0.0043	-0.1156	-1.1353	-0.1988	-5.9801	-0.0817	0.0404	0.0925	0.4962	-0.0251
M'	-0.0217	0.0118	0.7692	0.2458	-0.9537	-1.8553	0.3204	0.0610	0.0707	-1.0857

CASE	24	130 KT	LEVEL FLIGHT	1524 M	1157 KG	MID CG				
	PHI	THETA	PSI	ALPHA	BETA	GAMMA	ΘHR	B1S	A1S	ΘTR
	-2.74	-4.06	0.00	-4.06	0.19	0.00	17.32	6.90	-1.42	12.95
	XDOT	ZDOT	U0	V0	W0	VT0				
	66.88	0.00	66.71	0.23	-4.73	66.88				
	U	W	Q	V	P	R	DC	DB	DA	DP
X	-0.0551	0.0167	0.3889	0.0909	-0.2416	-0.0299	-0.0226	0.0910	-0.0040	-0.0247
Z	0.0165	-0.6755	-0.4624	-0.0391	-0.4367	0.5510	-0.9595	0.4342	0.0049	0.0179
M	0.0500	-0.0054	-3.2237	-0.0995	0.1210	0.5472	0.2512	-0.3345	0.0186	0.0931
Y	0.0022	-0.0433	-0.2698	-0.1250	-3.4648	0.3621	-0.0798	0.0157	0.0631	0.1963
L'	-0.0029	-0.1496	-1.2957	-0.2390	-5.4981	-0.0118	0.0303	0.0869	0.4984	-0.0171
M'	-0.0234	0.1860	0.5306	0.2845	-0.6669	-2.3853	0.5795	-0.0056	0.0641	-1.0829

TABLE II-3 CONCLUDED
OH-6A STABILITY AND CONTROL DERIVATIVES -- SI UNITS
(BODY-FIXED FRL AXIS SYSTEM)

CASE	60 KT			6 M/S		SEA LEVEL	1157 KG	MID CG		
	PHI	THETA	PSI	ALPHA	BETA	GAMMA	ΘMR	θ1S	θ1S	θTR
25	-2.63	0.62	0.00	-9.96	0.45	10.58	15.19	2.64	-0.97	12.71
	XDOT	ZDOT	U0	V0	W0	VTO				
	30.34	-5.67	30.40	0.24	-5.34	30.87				
	U	W	Q	V	P	R	DC	DB	DA	DP
X	-0.0308	0.0385	0.3630	0.0001	-0.2544	-0.0120	0.0024	0.0954	-0.0037	-0.0128
Z	-0.0245	-0.7023	-0.1539	-0.0227	-0.2821	0.4923	-0.9997	0.2170	0.0041	0.0033
H	0.0457	-0.0278	-2.1748	-0.0439	0.2977	0.2684	0.0974	-0.2951	0.0148	0.0235
Y	0.0069	-0.0218	-0.3034	-0.0906	-0.4612	0.2288	-0.0105	0.0056	0.0630	0.1878
L*	0.0092	-0.0711	-1.3601	-0.1859	-4.9720	-0.1344	0.0574	0.0722	0.5089	-0.0258
H*	-0.0482	0.0213	0.1343	0.2235	-0.9692	-1.5595	0.3476	0.0295	0.0772	-1.0334

CASE	60 KT			-8 M/S		SEA LEVEL	1157 KG	MID CG		
	PHI	THETA	PSI	ALPHA	BETA	GAMMA	ΘMR	θ1S	θ1S	θTR
26	-0.08	-0.20	0.00	15.09	-0.02	-15.29	8.91	0.23	0.25	6.50
	XDOT	ZDOT	U0	V0	W0	VTO				
	29.77	8.14	29.80	-0.01	8.03	30.87				
	U	W	Q	V	P	R	DC	DB	DA	DP
X	-0.0254	-0.0004	0.7968	0.0041	-0.1724	-0.0262	-0.0213	0.0912	-0.0062	-0.0022
Z	-0.0536	-0.7181	-0.2066	-0.0113	-0.2078	0.3014	-0.9738	0.2109	0.0041	0.0009
H	0.0146	-0.0261	-2.6651	-0.0570	0.1787	0.2752	0.1317	-0.2904	0.0170	0.0062
Y	-0.0037	-0.0082	-0.2534	-0.0754	-0.7968	0.2027	0.0065	0.0070	0.0575	0.1866
L*	-0.0215	-0.0746	-1.0646	-0.1203	-6.1313	-0.1793	0.0528	0.0848	0.4860	-0.0280
H*	-0.0041	-0.2073	0.7524	0.1989	-1.0032	-1.4288	-0.0062	0.0923	0.0734	-1.0234

TABLE II-4
OH-6A STABILITY AND CONTROL DERIVATIVES -- US UNITS
(BODY-FIXED FRL AXIS SYSTEM)

CASE	1	-40 KT		LEVEL FLIGHT AT SEA LEVEL			2550 LB	MID CG		
	PHI	THETA	PSI	ALPHA	BETA	GAMMA	ØMR	B1S	A1S	ØTR
	-2.03	3.76	0.00	-176.24	0.13	180.00	12.92	-2.58	-0.01	12.43
	IDOT	ZDOT	U0	V0	W0	VT0				
	-67.51	0.00	-67.37	0.16	-0.42	67.51				
	U	W	Q	V	P	R	DC	DB	DA	DP
X	-0.0439	0.0251	1.8145	0.0001	-0.7627	-0.0145	0.5544	0.9293	-0.0337	0.0535
Z	0.1559	-0.6323	-0.2270	-0.0177	0.3824	1.3540	-7.5711	-1.0542	-0.0209	-0.0377
H	0.0140	-0.0485	-2.2755	-0.0115	0.2764	0.2079	-0.3065	-0.7713	0.0364	-0.0311
Y	-0.0069	0.0080	-0.6201	-0.0678	-1.7191	0.5094	-0.0171	0.0755	0.5253	1.5678
L*	0.0011	-0.0188	-1.2755	-0.0434	-5.3893	-0.2253	0.0245	0.1518	1.2588	-0.0768
M*	0.0189	-0.0479	-0.8046	0.0713	-1.1928	-1.1483	0.5857	-0.0526	0.1664	-2.6145

CASE	2	-30 KT		LEVEL FLIGHT AT SEA LEVEL			2550 LB	MID CG		
	PHI	THETA	PSI	ALPHA	BETA	GAMMA	ØMR	B1S	A1S	ØTR
	-2.24	2.96	0.00	-177.04	0.12	180.00	13.24	-2.34	-0.03	13.72
	IDOT	ZDOT	U0	V0	W0	VT0				
	-50.63	0.00	-50.57	0.10	-2.61	50.63				
	U	W	Q	V	P	R	DC	DB	DA	DP
X	-0.0397	0.0173	1.6896	0.0002	-0.7799	-0.0257	0.4385	0.8982	-0.0355	0.0435
Z	0.1980	-0.5453	0.1472	-0.0232	0.5255	1.5799	-7.1588	-0.7427	0.0702	-0.0312
H	0.0157	-0.0357	-2.1514	-0.0084	0.2999	0.1740	-0.2294	-0.7549	0.0366	-0.0175
Y	-0.0060	0.0049	-0.6686	-0.0566	-1.6277	0.4433	-0.0137	0.0783	0.5236	1.4971
L*	0.0027	-0.0139	-1.2462	-0.0436	-5.2968	-0.2487	0.0637	0.1786	1.2584	-0.0713
M*	0.0177	-0.0334	-0.6168	0.0516	-1.1801	-1.0321	0.6656	-0.0276	0.1686	-2.4974

CASE	3	-20 KT		LEVEL FLIGHT AT SEA LEVEL			2550 LB	MID CG		
	PHI	THETA	PSI	ALPHA	BETA	GAMMA	ØMR	B1S	A1S	ØTR
	-2.58	2.39	0.00	-177.62	0.11	180.00	13.85	-2.04	-0.10	15.43
	IDOT	ZDOT	U0	V0	W0	VT0				
	-33.76	0.00	-33.73	0.06	-1.40	33.76				
	U	W	Q	V	P	R	DC	DB	DA	DP
X	-0.0346	0.0109	1.5245	0.0019	-0.7990	-0.0118	0.3590	0.8820	-0.0322	0.0358
Z	0.1984	-0.4344	-0.1287	-0.0492	0.1091	1.0238	-7.1815	-0.6213	-0.0471	-0.0238
H	0.0153	-0.0240	-2.0047	-0.0056	0.3334	0.1543	-0.1722	-0.7435	0.0387	-0.0007
Y	-0.0045	0.0055	-0.6915	-0.0467	-1.4651	0.4757	-0.0088	0.0843	0.5339	1.6559
L*	0.0029	-0.0091	-1.1905	-0.0431	-5.1219	-0.2131	0.0960	0.1951	1.2746	-0.0778
M*	0.0133	-0.0238	-0.5092	0.0334	-1.2004	-1.0663	0.7499	-0.0252	0.1599	-2.7632

TABLE II-4 CONTINUED
OH-6A STABILITY AND CONTROL DERIVATIVES -- US UNITS
(BODY-FIXED FRL AXIS SYSTEM)

CASE	0 KT		LEVEL FLIGHT AT SEA LEVEL				2550 LB	MID CG		
	PHI	THETA	PSI	ALPHA	BETA	GAMMA	ΘMR	B1S	A1S	ΘTR
4	-3.05	1.66	0.00	1.65	-0.09	0.00	14.70	-1.21	-0.22	17.33
	XDOT		ZDOT	U0	V0	W0	VT0			
	0.00		0.00	0.00	0.00	0.00	0.00			
	U	W	Q	V	P	R	DC	DB	DA	DP
X	-0.0257	0.0113	1.3031	0.0004	-0.8182	-0.0608	0.2167	0.8601	-0.0281	-0.0325
Z	-0.0422	-0.3404	0.0164	-0.0440	0.0582	1.4747	-7.3434	-0.0161	0.0110	-0.0380
M	0.0126	-0.0060	-1.7645	-0.0026	0.3763	0.0719	-0.0785	-0.7408	0.0350	-0.0096
Y	0.0158	-0.0194	-0.8441	-0.0435	-1.3463	0.3428	-0.0577	0.0387	0.5141	1.5340
L*	0.0003	-0.0019	-1.1360	-0.0462	-4.9198	-0.2873	0.1206	0.1874	1.2793	-0.0781
M*	-0.0262	0.0310	-0.1724	-0.0017	-1.0748	-0.8645	0.9507	0.0493	0.1982	-2.5676
CASE	20 KT		LEVEL FLIGHT AT SEA LEVEL				2550 LB	MID CG		
	PHI	THETA	PSI	ALPHA	BETA	GAMMA	ΘMR	B1S	A1S	ΘTR
5	-2.45	1.52	0.00	1.52	-0.06	0.00	13.84	-0.03	-0.36	14.63
	XDOT		ZDOT	U0	V0	W0	VT0			
	33.76		0.00	33.74	-0.04	0.89	33.76			
	U	W	Q	V	P	R	DC	DB	DA	DP
X	-0.0167	0.0216	1.5171	0.0024	-0.7792	-0.0989	0.0901	0.8302	-0.0005	-0.0504
Z	-0.1896	-0.4337	0.1585	-0.0370	-0.0019	1.5269	-6.9870	0.7010	0.1043	-0.0014
M	0.0156	-0.0030	-1.8793	-0.0019	0.3497	0.0954	0.0573	-0.7366	0.0355	0.0274
Y	0.0080	-0.0061	-0.7971	-0.0490	-1.5795	0.4836	-0.0095	0.0605	0.5211	1.5541
L*	0.0005	-0.0068	-1.1404	-0.0445	-5.1712	-0.2623	0.1320	0.1807	1.2678	-0.0701
M*	-0.0214	-0.0076	-0.1569	0.0251	-1.1071	-1.1038	0.7451	0.0350	0.1775	-2.6022
CASE	30 KT		LEVEL FLIGHT AT SEA LEVEL				2550 LB	MID CG		
	PHI	THETA	PSI	ALPHA	BETA	GAMMA	ΘMR	B1S	A1S	ΘTR
6	-2.00	1.68	0.00	1.68	-0.06	0.00	13.18	0.53	-0.41	12.54
	XDOT		ZDOT	U0	V0	W0	VT0			
	50.63		0.00	50.61	-0.05	1.48	50.63			
	U	W	Q	V	P	R	DC	DB	DA	DP
X	-0.0204	0.0180	1.6589	0.0038	-0.6973	-0.1691	0.0234	0.8191	-0.0362	-0.0457
Z	-0.1420	-0.5473	-0.2132	-0.0313	-0.2569	1.2557	-7.2944	0.8619	0.0208	0.0110
M	0.0164	-0.0006	-2.0215	-0.0045	0.3529	0.0824	0.0617	-0.7265	0.0391	0.0371
Y	0.0054	-0.0103	-0.8381	-0.0581	-1.7729	0.4722	-0.0487	0.0459	0.5042	1.3747
L*	0.0001	-0.0110	-1.1554	-0.0446	-5.3030	-0.2649	0.1066	0.1955	1.2681	-0.0598
M*	-0.0176	-0.0134	-0.0275	0.0382	-1.0852	-1.0691	0.7096	0.0836	0.1986	-2.3014

TABLE II-4 CONTINUED
OH-6A STABILITY AND CONTROL DERIVATIVES -- US UNITS
(BODY-FIXED FRL AXIS SYSTEM)

CASE	40 KT		LEVEL FLIGHT AT SEA LEVEL				2550 LB	MID CG		
	PHI	THETA	PSI	ALPHA	BETA	GAMMA	ΘHR	B1S	A1S	ΘTR
	-1.74	1.48	0.00	1.48	-0.04	0.00	12.79	0.96	-0.43	11.25
	IDOT	ZDOT	UO	VO	WO	VT0				
	67.51	0.00	67.49	-0.05	1.74	67.51				
	U	W	Q	V	P	R	DC	DB	DA	DP
X	-0.0270	0.0125	1.7025	0.0008	-0.7496	-0.0553	0.0480	0.7974	-0.0386	-0.0480
Z	-0.0941	-0.6299	-0.5131	-0.0234	-0.4076	1.4486	-7.5579	1.1230	0.0481	0.0183
H	0.0130	-0.0034	-2.2421	-0.0108	0.2852	0.1843	0.1576	-0.7310	0.0386	0.0428
Y	0.0041	-0.0120	-0.8925	-0.0679	-1.9293	0.4781	-0.0312	0.0457	0.5021	1.3445
L'	-0.0019	-0.0174	-1.2325	-0.0479	-5.4483	-0.2164	0.1262	0.1959	1.2638	-0.0570
M'	-0.0143	-0.0217	0.1582	0.0504	-1.0122	-1.1024	0.5804	0.1108	0.1993	-2.2509

CASE	60 KT		LEVEL FLIGHT AT SEA LEVEL				2550 LB	MID CG		
	PHI	THETA	PSI	ALPHA	BETA	GAMMA	ΘHR	B1S	A1S	ΘTR
	-1.54	0.58	0.00	0.58	-0.02	0.00	12.59	1.79	-0.48	10.08
	IDOT	ZDOT	UO	VO	WO	VT0				
	101.27	0.00	101.26	-0.03	1.02	101.27				
	U	W	Q	V	P	R	DC	DB	DA	DP
X	-0.0314	0.0107	1.8063	0.0015	-0.7330	-0.0511	-0.0471	0.7747	-0.0370	-0.0600
Z	-0.0371	-0.7150	-0.7060	-0.0210	-0.9559	1.3307	-8.2958	1.8424	0.0266	0.0431
H	0.0105	-0.0040	-2.4843	-0.0186	0.2077	0.2636	0.2750	-0.7463	0.0367	0.0797
Y	0.0009	-0.0186	-0.9996	-0.0836	-1.9421	0.6765	-0.0323	0.0519	0.5016	1.5936
L'	-0.0025	-0.0257	-1.3056	-0.0501	-5.4853	-0.1582	0.1211	0.1852	1.2550	-0.0820
M'	-0.0073	-0.0244	0.5060	0.0646	-1.1022	-1.4412	0.4629	0.1437	0.1883	-2.6705

CASE	80 KT		LEVEL FLIGHT AT SEA LEVEL				2550 LB	MID CG		
	PHI	THETA	PSI	ALPHA	BETA	GAMMA	ΘHR	B1S	A1S	ΘTR
	-1.60	-0.77	0.00	-0.77	0.02	0.00	13.02	2.57	-0.60	9.85
	IDOT	ZDOT	UO	VO	WO	VT0				
	135.02	0.00	135.01	0.05	-1.82	135.02				
	U	W	Q	V	P	R	DC	DB	DA	DP
X	-0.0379	0.0064	1.7497	0.0011	-0.7229	-0.0641	-0.1749	0.7494	-0.0411	-0.0940
Z	-0.0126	-0.7655	-0.7199	-0.0249	-1.1828	1.5283	-8.9288	2.6539	0.0274	0.0453
H	0.0106	-0.0026	-2.6776	-0.0227	0.2004	0.3948	0.3990	-0.7540	0.0415	0.0724
Y	0.0018	-0.0218	-0.9221	-0.0994	-1.9594	0.9452	-0.0296	0.0818	0.5176	1.7909
L'	-0.0011	-0.0317	-1.3420	-0.0541	-5.4042	-0.0739	0.1423	0.2007	1.2654	-0.0700
M'	-0.0073	-0.0246	0.5444	0.0765	-0.9747	-1.8727	0.4208	0.1406	0.1642	-1.0011

TABLE II-4 CONTINUED
OH-6A STABILITY AND CONTROL DERIVATIVES -- US UNITS
(BODY-FIXED FRL AXIS SYSTEM)

CASE 10	100 KT			LEVEL FLIGHT AT SEA LEVEL			2550 LB	MID CG		
	PHI	THETA	PSI	ALPHA	BETA	GAMMA	ΘMR	B1S	A1S	ΘTR
	-1.88	-2.14	0.00	-2.14	0.07	0.00	14.03	3.89	-0.86	10.18
	IDOT	ZDOT	UO	VO	WO	VTO				
	168.78	0.00	168.66	0.21	-6.30	168.78				
	U	W	Q	V	P	R	DC	DB	DA	DP
X	-0.0437	0.0081	1.5842	0.0015	-0.7338	-0.0515	-0.2188	0.7329	-0.0341	-0.1237
Z	0.0023	-0.7977	-0.8934	-0.0374	-1.5818	1.5950	-9.4861	3.3472	0.0043	0.0914
H	0.0105	-0.0028	-2.8275	-0.0298	0.1469	0.4617	0.4989	-0.7764	0.0393	0.1484
Y	0.0021	-0.0325	-1.1926	-0.1174	-1.8009	1.0293	-0.1012	0.0665	0.5092	1.8299
L'	-0.0009	-0.0377	-1.4309	-0.0617	-5.2565	-0.0058	0.1422	0.1943	1.2713	-0.1057
M'	-0.0074	-0.0038	1.0475	0.0892	-0.9802	-2.0187	0.5988	0.1716	0.1855	-3.0738

CASE 11	120 KT			LEVEL FLIGHT AT SEA LEVEL			2550 LB	MID CG		
	PHI	THETA	PSI	ALPHA	BETA	GAMMA	ΘMR	B1S	A1S	ΘTR
	-2.34	-3.94	0.00	-3.94	0.16	0.00	15.64	5.41	-1.32	10.81
	IDOT	ZDOT	UO	VO	WO	VTO				
	202.54	0.00	202.06	0.57	-13.91	202.54				
	U	W	Q	V	P	R	DC	DB	DA	DP
X	-0.0536	0.0075	1.2132	0.0003	-0.7981	-0.0744	-0.2886	0.7085	-0.0340	-0.2170
Z	0.0127	-0.8050	-0.7570	-0.0444	-1.7506	1.9030	-9.6053	4.0888	0.0325	0.0871
H	0.0131	-0.0014	-2.9488	-0.0329	0.1673	0.5662	0.6281	-0.7993	0.0428	0.1297
Y	0.0026	-0.0421	-1.0644	-0.1344	-1.6194	1.2626	-0.2043	0.1027	0.5237	1.9667
L'	0.0003	-0.0455	-1.5519	-0.0716	-5.0022	0.0595	0.1217	0.1897	1.2836	-0.0714
M'	-0.0075	0.0213	0.7900	0.0987	-0.8117	-2.4360	0.9181	0.0844	0.1805	-3.3069

CASE 12	130 KT			LEVEL FLIGHT AT SEA LEVEL			2550 LB	MID CG		
	PHI	THETA	PSI	ALPHA	BETA	GAMMA	ΘMR	B1S	A1S	ΘTR
	-2.66	-4.80	0.00	-4.80	0.22	0.00	16.70	6.48	-1.61	11.46
	IDOT	ZDOT	UO	VO	WO	VTO				
	219.42	0.00	218.64	0.85	-18.35	219.42				
	U	W	Q	V	P	R	DC	DB	DA	DP
X	-0.0570	0.0138	0.9531	0.0001	-0.8457	-0.0789	-0.2938	0.6888	-0.0338	-0.2645
Z	0.0178	-0.8096	-1.0144	-0.0485	-1.9111	2.0487	-9.7222	4.3435	0.0357	0.1178
H	0.0152	-0.0020	-2.9912	-0.0354	0.1693	0.6034	0.6736	-0.8228	0.0438	0.1680
Y	0.0036	-0.0488	-1.0486	-0.1438	-1.3789	1.3700	-0.2829	0.1361	0.5331	1.9331
L'	0.0014	-0.0505	-1.6260	-0.0775	-4.8062	0.0913	0.0912	0.1773	1.2925	-0.0652
M'	-0.0092	0.0409	0.6085	0.1037	-0.8152	-2.6430	1.1948	-0.0286	0.1794	-3.2550

TABLE II-4 CONTINUED
OH-6A STABILITY AND CONTROL DERIVATIVES -- US UNITS
(BODY-FIXED FRL AXIS SYSTEM)

CASE 13		0 KT		LEVEL FLIGHT AT SEA LEVEL			2550 LB	FWD CG		
	PHI	THETA	PSI	ALPHA	BETA	GAMMA	ΘMR	B1S	A1S	ΘTR
	-3.05	0.20	0.00	0.20	-0.01	0.00	14.70	-2.58	-0.10	17.16
	XDOT	ZDOT	UO	VO	WO	VT0				
	0.00	0.00	0.00	0.00	0.00	0.00				
	U	W	Q	V	P	R	DC	DB	DA	DP
X	-0.0267	0.0036	1.3039	-0.0008	-0.8226	-0.0195	0.0248	0.8569	-0.0288	-0.0293
Z	-0.0555	-0.3449	0.0016	-0.0457	0.2204	1.5963	-7.2910	0.0323	0.0463	-0.0371
H	0.0118	-0.0109	-1.7601	-0.0031	0.3867	0.0866	-0.1665	-0.7368	0.0368	-0.0103
Y	0.0156	-0.0197	-0.8527	-0.0437	-1.3486	0.3488	-0.0601	0.0353	0.5131	1.5186
L*	-0.0001	-0.0024	-1.0767	-0.0463	-4.8978	-0.2795	0.1209	0.1832	1.2761	-0.0896
M*	-0.0270	0.0313	0.2259	-0.0008	-1.0287	-0.8760	0.9546	0.0509	0.1867	-2.5848

CASE 14		100 KT		LEVEL FLIGHT AT SEA LEVEL			2550 LB	FWD CG		
	PHI	THETA	PSI	ALPHA	BETA	GAMMA	ΘMR	B1S	A1S	ΘTR
	-1.78	-3.54	0.00	-3.54	0.11	0.00	14.05	2.54	-0.84	9.80
	XDOT	ZDOT	UO	VO	WO	VT0				
	168.78	0.00	168.46	0.32	-10.42	168.78				
	U	W	Q	V	P	R	DC	DB	DA	DP
X	-0.0439	-0.0095	1.5463	0.0004	-0.7628	0.0013	-0.4437	0.8215	-0.0300	-0.1344
Z	-0.0160	-0.7995	-1.1060	-0.0369	-1.5381	1.6069	-9.5068	3.3057	-0.0084	0.0510
H	0.0106	-0.0146	-2.8644	-0.0292	0.1390	0.4761	0.3643	-0.7413	0.0336	0.0780
Y	0.0015	-0.0328	-1.0170	-0.1173	-1.8808	1.0993	-0.1146	0.0810	0.5135	1.9022
L*	-0.0015	-0.0414	-1.4157	-0.0628	-5.2860	-0.0495	0.1030	0.1779	1.2552	-0.0922
M*	-0.0081	-0.0062	1.1367	0.0914	-0.8335	-2.1766	0.5884	0.1521	0.1627	-3.2454

CASE 15		130 KT		LEVEL FLIGHT AT SEA LEVEL			2550 LB	FWD CG		
	PHI	THETA	PSI	ALPHA	BETA	GAMMA	ΘMR	B1S	A1S	ΘTR
	-2.60	-6.22	0.00	-6.22	0.28	0.00	16.96	5.56	-1.69	11.15
	XDOT	ZDOT	UO	VO	WO	VT0				
	219.42	0.00	218.12	1.08	-23.76	219.42				
	U	W	Q	V	P	R	DC	DB	DA	DP
X	-0.0585	0.0136	0.9021	-0.0012	-0.8890	-0.0256	-0.4518	0.7858	-0.0287	-0.2523
Z	0.0054	-0.8085	-1.2746	-0.0497	-1.8568	2.1065	-9.6876	4.2947	0.0339	0.0864
H	0.0169	-0.0153	-3.0149	-0.0359	0.1444	0.6368	0.5166	-0.7660	0.0416	0.1257
Y	0.0042	-0.0514	-1.0450	-0.1450	-1.3404	1.4402	-0.3072	0.1512	0.5398	2.0051
L*	0.0026	-0.0518	-1.5831	-0.0773	-4.7637	0.1053	0.0806	0.1916	1.2958	-0.0925
M*	-0.0111	0.0484	0.8704	0.1089	-0.7804	-2.7851	1.2912	-0.0448	0.1663	-3.4321

TABLE II-4 CONTINUED
OH-6A STABILITY AND CONTROL DERIVATIVES -- US UNITS
(BODY-FIXED FRL AXIS SYSTEM)

CASE 16	0 KT LEVEL FLIGHT AT SEA LEVEL 2550 LB APT CG									
	PHI	THETA	PSI	ALPHA	BETA	GAMMA	ΘMR	B1S	A1S	ΘTR
	-3.08	3.60	0.00	3.59	-0.19	0.00	14.73	0.59	-0.38	17.46
	XDOT	ZDOT	UO	VO	WO	VTO				
	0.00	0.00	0.00	0.00	0.00	0.00				
	U	W	Q	V	P	R	DC	DB	DA	DP
X	-0.0258	0.0218	1.2925	0.0026	-0.8203	-0.1221	0.4668	0.8638	-0.0292	-0.0325
Z	-0.0245	-0.3372	0.1247	-0.0587	-0.0669	1.4095	-7.3634	-0.0352	-0.0074	-0.0359
M	0.0135	0.0001	-1.7584	-0.0015	0.3822	0.0681	0.0475	-0.7390	0.0369	-0.0046
Y	0.0159	-0.0187	-0.8456	-0.0428	-1.3522	0.3311	-0.0554	0.0397	0.5166	1.5389
L*	0.0006	-0.0015	-1.2357	-0.0467	-4.9471	-0.2927	0.1244	0.1881	1.2872	-0.0610
M*	-0.0254	0.0304	-0.6567	-0.0048	-1.1246	-0.8418	0.9507	0.0503	0.2162	-2.5172

CASE 17	100 KT LEVEL FLIGHT AT SEA LEVEL 2550 LB APT CG									
	PHI	THETA	PSI	ALPHA	BETA	GAMMA	ΘMR	B1S	A1S	ΘTR
	-1.97	-0.59	0.00	-0.59	0.02	0.00	13.96	5.33	-0.90	10.63
	XDOT	ZDOT	UO	VO	WO	VTO				
	168.78	0.00	168.77	0.06	-1.74	168.78				
	U	W	Q	V	P	R	DC	DB	DA	DP
X	-0.0447	0.0250	1.5419	0.0021	-0.6978	-0.1300	0.0214	0.6288	-0.0394	-0.1496
Z	0.0215	-0.7961	-0.6147	-0.0351	-1.5860	1.5898	-9.4732	3.3887	0.0162	0.0676
M	0.0090	0.0141	-2.7721	-0.0270	0.2130	0.4646	0.6941	-0.8331	0.0438	0.1010
Y	0.0015	-0.0281	-1.0041	-0.1159	-1.8596	1.0313	-0.0806	0.0633	0.5089	1.8945
L*	-0.0013	-0.0354	-1.5136	-0.0624	-5.2544	-0.0079	0.1668	0.1867	1.2752	-0.0518
M*	-0.0053	-0.0090	0.2889	0.0829	-0.9133	-1.9918	0.5812	0.1595	0.1965	-3.1075

CASE 18	130 KT LEVEL FLIGHT AT SEA LEVEL 2550 LB APT CG									
	PHI	THETA	PSI	ALPHA	BETA	GAMMA	ΘMR	B1S	A1S	ΘTR
	-2.85	-3.37	0.00	-3.37	0.17	0.00	16.69	7.94	-1.56	12.23
	XDOT	ZDOT	UO	VO	WO	VTO				
	219.42	0.00	219.04	0.64	-12.90	219.42				
	U	W	Q	V	P	R	DC	DB	DA	DP
X	-0.0606	0.0297	0.9560	0.0026	-0.7631	-0.1374	-0.0156	0.5617	-0.0318	-0.2427
Z	0.0346	-0.8101	-0.7869	-0.0487	-2.0360	1.9696	-9.7572	4.3630	0.0284	0.1387
M	0.0124	0.0143	-2.9547	-0.0347	0.1900	0.5635	0.8612	-0.9110	0.0399	0.2065
Y	0.0040	-0.0453	-1.0202	-0.1423	-1.3420	1.3531	-0.2529	0.1214	0.5317	1.9328
L*	0.0006	-0.0470	-1.7643	-0.0784	-4.7813	0.0845	0.1286	0.1577	1.2964	-0.0390
M*	-0.0092	0.0383	0.1635	0.0967	-0.8628	-2.5713	1.1743	-0.0384	0.1943	-3.1780

TABLE 11-4 CONTINUED
OH-6A STABILITY AND CONTROL DERIVATIVES -- US UNITS
(BODY-FIXED FRL AXIS SYSTEM)

CASE	19	0 KT	LEVEL FLIGHT AT SEA LEVEL				2200 LB	MID CG			
	PHI	THETA	PSI	ALPHA	BETA	GAMMA	ΘHR	B1S	A1S	ΘTR	
	-3.01	1.77	0.00	1.76	-0.09	0.00	13.78	-1.13	-0.19	15.95	
		XDOT	ZDOT	UO	VO	WO	VTO				
		0.00	0.00	0.00	0.00	0.00	0.00				
		U	W	Q	V	P	R	DC	DB	DA	DP
X	-0.0240	0.0137	1.2230	0.0012	-0.8221	-0.0654	0.2609	0.8601	-0.0260	-0.0387	
Z	-0.0595	-0.3877	-0.0667	-0.0655	0.0013	1.3837	-8.4119	0.0187	-0.0146	-0.0315	
H	0.0104	-0.0061	-1.7089	-0.0033	0.3481	0.0605	-0.0844	-0.7194	0.0334	-0.0028	
Y	0.0165	-0.0210	-0.8565	-0.0432	-1.2802	0.3849	-0.0610	0.0286	0.5113	1.7860	
L'	-0.0004	-0.0017	-1.1067	-0.0405	-5.0207	-0.2977	0.1365	0.1861	1.3026	-0.1170	
M'	-0.0250	0.0319	-0.1862	-0.0004	-1.1131	-0.8438	0.9050	0.0566	0.2131	-2.7080	

CASE	20	100 KT	LEVEL FLIGHT AT SEA LEVEL				2200 LB	MID CG			
	PHI	THETA	PSI	ALPHA	BETA	GAMMA	ΘHR	B1S	A1S	ΘTR	
	-2.06	-2.86	0.00	-2.86	0.10	0.00	13.46	3.48	-0.85	9.69	
		XDOT	ZDOT	UO	VO	WO	VTO				
		168.78	0.00	168.57	0.30	-8.42	168.78				
		U	W	Q	V	P	R	DC	DB	DA	DP
X	-0.0483	0.0122	1.3737	0.0004	-0.7576	-0.0623	-0.2092	0.6947	-0.0377	-0.1506	
Z	0.0093	-0.9375	-0.9210	-0.0375	-1.6918	1.8317	-11.0616	3.9330	0.0342	0.0554	
H	0.0096	-0.0045	-2.7468	-0.0286	0.1533	0.4914	0.4895	-0.7444	0.0416	0.0770	
Y	0.0023	-0.0340	-1.0665	-0.1313	-1.8017	1.2770	-0.0905	0.0677	0.5175	2.2063	
L'	-0.0003	-0.0387	-1.4729	-0.0596	-5.3111	-0.0091	0.1628	0.1864	1.2995	-0.1267	
M'	-0.0061	-0.0037	0.6236	0.0922	-0.9092	-2.1983	0.5245	0.1251	0.1902	-3.3526	

CASE	21	130 KT	LEVEL FLIGHT AT SEA LEVEL				2200 LB	MID CG			
	PHI	THETA	PSI	ALPHA	BETA	GAMMA	ΘHR	B1S	A1S	ΘTR	
	-2.98	-6.01	0.00	-6.01	0.31	0.00	16.62	6.50	-1.74	10.72	
		XDOT	ZDOT	UO	VO	WO	VTO				
		219.42	0.00	218.21	1.19	-22.96	219.42				
		U	W	Q	V	P	R	DC	DB	DA	DP
X	-0.0636	0.0376	0.6203	-0.0007	-0.8514	-0.0562	-0.1692	0.6324	-0.0243	-0.2644	
Z	0.0261	-0.9657	-0.8739	-0.0596	-2.2409	2.2705	-11.6727	5.1251	0.0245	0.0983	
H	0.0144	-0.0065	-2.8787	-0.0362	0.1318	0.6142	0.6160	-0.7834	0.0389	0.1233	
Y	0.0049	-0.0551	-1.2399	-0.1646	-1.2603	1.6361	-0.2968	0.1088	0.5441	2.3176	
L'	0.0027	-0.0489	-1.7526	-0.0775	-4.7659	0.1038	0.1556	0.1562	1.3332	-0.1267	
M'	-0.0083	0.0495	0.5284	0.1106	-0.7973	-2.7841	1.1701	-0.0448	0.2005	-3.5312	

TABLE II-4 CONTINUED
OH-6A STABILITY AND CONTROL DERIVATIVES -- US UNITS
(BODY-FIXED FRL AXIS SYSTEM)

CASE	22	0 KT	LEVEL FLIGHT	5000 FT	2550 LB	MID CG				
	PHI	THETA	PSI	ALPHA	BETA	GAMMA	ΘMR	BIS	AIS	ΘTR
	-3.18	1.66	0.00	1.65	-0.09	0.00	15.75	-1.21	-0.22	18.99
	IDOT	ZDOT	UO	VO	WO	VTO				
	0.00	0.00	0.00	0.00	0.00	0.00				
	U	W	Q	V	P	R	DC	DB	DA	DP
X	-0.0272	0.0101	1.5204	0.0010	-0.7823	-0.0632	0.1891	0.8573	-0.0328	-0.0396
Z	-0.0334	-0.3001	0.1288	-0.0425	0.3089	1.5434	-6.4051	0.0457	0.0327	-0.0268
M	0.0139	-0.0054	-2.0493	-0.0029	0.3207	0.0788	-0.0686	-0.7391	0.0388	0.0122
Y	0.0140	-0.0182	-0.7845	-0.0432	-1.5422	0.2862	-0.0456	0.0525	0.5152	1.3594
L'	-0.0017	-0.0020	-0.9629	-0.0522	-5.7392	-0.3433	0.1066	0.2045	1.2651	-0.0679
M'	-0.0248	0.0278	-0.1537	-0.0061	-1.2085	-0.8117	0.9150	0.0401	0.1894	-2.2763

CASE	23	100 KT	LEVEL FLIGHT	5000 FT	2550 LB	MID CG				
	PHI	THETA	PSI	ALPHA	BETA	GAMMA	ΘMR	BIS	AIS	ΘTR
	-1.84	-1.69	0.00	-1.69	0.05	0.00	14.77	4.18	-0.80	10.90
	IDOT	ZDOT	UO	VO	WO	VTO				
	168.78	0.00	168.71	0.16	-4.98	168.78				
	U	W	Q	V	P	R	DC	DB	DA	DP
X	-0.0417	0.0043	1.8047	0.0011	-0.7167	-0.0824	-0.2304	0.7563	-0.0448	-0.1371
Z	0.0027	-0.6574	-0.6645	-0.0261	-1.0949	1.6074	-7.7135	2.8567	0.0329	0.0563
M	0.0124	0.0030	-2.9885	-0.0239	0.1738	0.4456	0.5240	-0.7756	0.0517	0.0877
Y	0.0010	-0.0291	-0.8743	-0.1038	-2.0469	0.9049	-0.1308	0.0839	0.5059	1.6426
L'	-0.0013	-0.0352	-1.1353	-0.0606	-5.9801	-0.0817	0.1027	0.2350	1.2605	-0.0636
M'	-0.0066	0.0036	0.7692	0.0749	-0.9537	-1.8553	0.8138	0.1551	0.1797	-2.7576

CASE	24	130 KT	LEVEL FLIGHT	5000 FT	2550 LB	MID CG				
	PHI	THETA	PSI	ALPHA	BETA	GAMMA	ΘMR	BIS	AIS	ΘTR
	-2.74	-4.06	0.00	-4.06	0.19	0.00	17.32	6.90	-1.42	12.95
	IDOT	ZDOT	UO	VO	WO	VTO				
	219.42	0.00	218.86	0.74	-15.53	219.42				
	U	W	Q	V	P	R	DC	DB	DA	DP
X	-0.0551	0.0167	1.2758	0.0009	-0.7925	-0.0976	-0.1887	0.7586	-0.0334	-0.2059
Z	-0.0165	-0.6755	-1.5170	-0.0391	-1.4327	1.8076	-7.9962	3.6181	0.0412	0.1489
M	0.0152	-0.0017	-3.2237	-0.0303	0.1210	0.5472	0.6379	-0.8496	0.0472	0.2365
Y	0.0022	-0.0433	-0.8851	-0.1250	-1.5250	1.1880	-0.2486	0.1312	0.5258	1.6356
L'	-0.0009	-0.0456	-1.2957	-0.0728	-5.4983	-0.0138	0.0769	0.2209	1.2660	-0.0435
M'	-0.0071	0.0567	0.5306	0.0867	-0.6669	-2.3853	1.4718	-0.0141	0.1735	-2.7506

TABLE II-4 CONCLUDED
OH-6A STABILITY AND CONTROL DERIVATIVES -- US UNITS
(BODY-FIXED FRL AXIS SYSTEM)

CASE	25	60 KT	1116 FT/HIN	SEA LEVEL	2550 LB	MID CG				
	PHI	THETA	PSI	ALPHA	BETA	GAMMA	ΘMR	B1S	A1S	ΘTR
	-2.63	0.62	0.00	-9.96	0.45	10.58	15.19	2.64	-0.97	12.71
	XDOT		ZDOT	UO	VO	WO	VTO			
	99.55		-18.60	99.74	0.80	-17.51	101.27			
	U	W	Q	V	P	R	DC	DB	DA	DP
X	-0.0308	0.0385	1.1910	0.0001	-0.8346	-0.0395	0.0199	0.7946	-0.0310	-0.1065
Z	-0.0245	-0.7023	-0.5048	-0.0227	-0.9254	1.6151	-8.3309	1.8087	0.0339	0.0279
H	0.0139	-0.0085	-2.1748	-0.0134	0.2977	0.2684	0.2474	-0.7496	0.0375	0.0597
Y	0.0069	-0.0218	-0.9955	-0.0906	-1.5130	0.7507	-0.0876	0.0464	0.5247	1.5646
L'	0.0028	-0.0217	-1.3601	-0.0567	-4.9720	-0.1344	0.1457	0.1833	1.2925	-0.0656
M'	-0.0147	0.0065	0.1343	0.0681	-0.9692	-1.5595	0.8829	0.0749	0.1962	-2.6249

CASE	26	60 KT	-1602 FT/HIN	SEA LEVEL	2550 LB	MID CG				
	PHI	THETA	PSI	ALPHA	BETA	GAMMA	ΘMR	B1S	A1S	ΘTR
	-0.08	-0.20	0.00	15.09	-0.02	-15.29	8.91	0.23	0.25	6.50
	XDOT		ZDOT	UO	VO	WO	VTO			
	97.69		26.70	97.78	-0.04	26.36	101.27			
	U	W	Q	V	P	R	DC	DB	DA	DP
X	-0.0254	-0.0004	2.6141	0.0041	-0.5657	-0.0861	-0.1776	0.7600	-0.0516	-0.0181
Z	-0.0536	-0.7181	-0.6779	-0.0113	-0.6817	0.9888	-8.1153	1.7578	0.0343	0.0079
H	0.0045	-0.0080	-2.6651	-0.0174	0.1787	0.2752	0.3346	-0.7376	0.0432	0.0158
Y	-0.0037	-0.0082	-0.8314	-0.0754	-2.6141	0.6649	0.0539	0.0581	0.4795	1.5546
L'	-0.0066	-0.0227	-1.0646	-0.0367	-6.1313	-0.1793	0.1340	0.2155	1.2344	-0.0712
M'	-0.0012	-0.0632	0.7524	0.0606	-1.0032	-1.4288	-0.0158	0.2345	0.1865	-2.5995

TABLE II-5 OH-6A TRANSFER FUNCTION FACTORS

CASE I -40 KT

DENOMINATOR: (0) (-.0433) (.0982) (-1.72) (5.15) [-.916;.402][.987;3.45]<.0723>

CONTROL NUMERATORS:

PHI/DA 1.27 (0) (.101) (-1.75) [-.902;.400][.987;3.25]<-.378>
 THE/DB -0.773 (0) (.0345) (-.0432) (.576) (-1.74) (3.01) (5.30) <-.0184>
 PSI/DP -2.62 (.109) (3.61) (5.29) [-.861;.382][-.0378;.512]<-.208>

PHI/DB 1.52 (0) (.0539) (-.211) (3.50) [-.984;1.21]<-.0577>
 THE/DA .586 (0) (.0349) (-.0492) (.533) (-1.80) (2.52) <.00244>

PHI/DA ;THE/DB -0.987 (0) (.0345) (.573) (-1.76) (2.88) <.0990>
 PHI/DA ;PSI/DP -3.28 (0) (.0880) (3.43) [-.843;.364]<-.132>
 THE/DB ;PSI/DP 2.02 (.0346) (.552) (5.41) [-.0777;.536] <.0601>

PHI/DB ;PSI/DP -0.399 (.0169) (-.379) (9.77) [.0485;.291] <.00212>
 PHI/DP ;THE/DB .210 (0) (.0346) (.543) (-4.40) (7.23) <-.126>
 PHI/DC ;THE/DB -0.282 (0) (.0349) (1.54) (-5.22) <.0793>

THE/DA ;PSI/DP -1.41 (.0374) (.456) (-.862) (1.17) <.0243>
 THE/DP ;PHI/DA -0.147 (0) (.0374) (.470) (-2.26) (8.75) <.0509>
 THE/DC ;PHI/DA -0.365 (0) (.0386) (2.58) [-.971;1.35] <-.0662>

PSI/DA ;THE/DB -0.127 (.0345) (.571) (2.04) [-.943;3.05] <-.0472>
 PSI/DB ;PHI/DA -0.0568 (.0137) (.180) (-.285) [-.654;6.60] <.00175>
 XD/DB ;PHI/DA 1.09 (0) (.703) (-1.76) (2.80) [.0692;4.99] <-94.9>

YD/DA ;THE/DB -0.407 (.0345) (.573) (-1.77) (2.92) [.0813;8.75] <3.19>
 ZD/DB ;PHI/DA -1.41 (0) (-.0523) (-1.76) (3.01) [.189;5.17] <-10.4>
 XD/DC ;PHI/DA 12.0 (0) (2.55) [-.984;1.34] <54.8>

YD/DP ;THE/DB -1.20 (.0346) (.545) [-.643;2.79] [.959;4.79] <-4.05>
 ZD/DC ;PHI/DA -9.63 (0) (-.0985) (-.690) (-1.71) [.970;2.98] <9.93>

PHI/DA ;THE/DB ;PSI/DP 2.55 (.00232) (.0352) (.559) <.000116>
 PHI/DC ;THE/DB ;PSI/DP -0.111 (.0335) (-.0946) (-2.55) <-.000899>
 THE/DC ;PHI/DA ;PSI/DP 1.03 (-.0163) (.0383) (-.503) <.000323>

PSI/DC ;PHI/DA ;THE/DB -0.598 (.0264) (.0470) (1.05) <-.000779>
 XD/DB ;PHI/DA ;PSI/DP -2.83 (.00190) (.666) [.0644;4.99] <-.0891>
 YD/DA ;THE/DB ;PSI/DP 1.26 (.0355) (.558) [.0261;8.06] <1.62>

ZD/DC ;PHI/DA ;THE/DB 7.08 (0) (.0219) (-1.77) (2.81) <-.770>
 ZD/DC ;PHI/DA ;PSI/DP 25.0 (-.00865) (-.140) (-.370) (2.77) <-.0310>
 XD/DC ;PHI/DA ;THE/DB .257 (0) (2.50) [-.927;1.88] <2.28>

XD/DC ;PHI/DA ;PSI/DP -33.1 (-.0168) (-.497) <-.276>
 YD/DP ;PHI/DA ;THE/DB -1.65 (.0405) (.369) [-.242;.564] <-.00784>
 ZD/DB ;PHI/DA ;PSI/DP 3.64 (.00122) (-.0488) [.194;5.20] <-.00584>

ZD/DC ;PHI/DA ;THE/DB ;PSI/DP -18.2 (.0107) (.0192) <-.00376>
 XD/DC ;PHI/DA ;THE/DB ;PSI/DP -0.714 (-.00872) (-1.16) <-.00724>

TABLE II-5 CONTINUED
OH-6A TRANSFER FUNCTION FACTORS

CASE 3 -20KT

DENOMINATOR: (0) (.116) (-.302) (-.470) (2.06) (2.47) (5.01) [-.188; .460] <.0885>

CONTROL NUMERATORS:

PHI/DA 1.28 (0) (.125) (-.734) (2.04) (2.22) [-.199; .452] <-.110>
THE/DB -.744 (0) (.0245) (-.299) (.430) (-.459) (1.81) (5.07) <-.00988>
PSI/DP -2.76 (.125) (2.61) (5.03) [-.257; .438] [.0349; .518] <-.234>

PHI/DB .195 (0) (.0563) (-.753) (2.07) (6.94) [-.106; .541] <-.0349>
THE/DA .638 (0) (.0278) (-.318) (.512) (-.621) (1.57) <.00281>

PHI/DA ; THE/DB -.962 (0) (.0247) (.441) (-.734) (1.74) <.0133>
PHI/DA ; PSI/DP -3.51 (.00428) (.126) (2.47) [-.181; .442] <-.000911>
THE/DB ; PSI/DP 2.06 (.0248) (-.392) (5.09) [-.0463; .535] <.0292>

PHI/DB ; PSI/DP -.538 (.888) [-.174; .0115] [.231; .357] <-.626E-4>
PHI/DP ; THE/DB .168 (0) (.0248) (.384) (-3.43) (5.57) <-.0305>
PHI/DC ; THE/DB -.0679 (0) (.0253) (.703) (-2.57) (5.14) <.0159>

THE/DA ; PSI/DP -1.71 (.0296) (.110) (-.474) (.818) <.00216>
THE/DP ; PHI/DA -.152 (0) (.0294) (.153) (-.530) (6.16) <.00223>
THE/DC ; PHI/DA -.183 (0) (.0316) (-.538) (1.34) (-1.57) <-.00654>

PSI/DA ; THE/DB -.118 (.0247) (.447) (1.29) (-1.86) (-4.09) <-.0128>
PSI/DB ; PHI/DA .238 (.00315) (-.0914) [-.999; 1.22] <.000102>
XD/DB ; PHI/DA 1.10 (0) (.477) (-.734) (1.72) [.0667; 5.21] <-18.0>

YD/DA ; THE/DB -.398 (.0247) (.440) (-.744) (1.75) [.101; 8.75] <.431>
ZD/DB ; PHI/DA -.833 (0) (-.365) (-.730) (1.89) [.223; 4.07] <-6.94>
XD/DC ; PHI/DA .0813 (0) (-.524) (1.33) (-1.45) [.0788; 8.94] <6.55>

YD/DP ; THE/DB -1.22 (.0248) (.396) (3.40) (4.78) [-.639; 2.28] <-.985>
ZD/DC ; PHI/DA -9.19 (0) (-.655) [-.460; .399] [.987; 2.00] <3.83>

PHI/DA ; THE/DB ; PSI/DP 2.63 (.00425) (.0248) (.407) <.000113>
PHI/DC ; THE/DB ; PSI/DP .0606 (.0245) (-.0795) (3.42) <-.000404>
THE/DC ; PHI/DA ; PSI/DP .613 (.00149) (.0317) (-.558) <-.161E-4>

PSI/DC ; PHI/DA ; THE/DB -.717 (.0190) (.0283) (.611) <-.000235>
XD/DB ; PHI/DA ; PSI/DP -3.02 (.00426) (.437) [-.0653; 5.20] <-.152>
YD/DA ; THE/DB ; PSI/DP 1.29 (.0248) (.403) [-.0378; 8.09] <.846>

ZD/DC ; PHI/DA ; THE/DB 6.78 (0) (.00751) (-.648) (1.60) <-.0528>
ZD/DC ; PHI/DA ; PSI/DP 25.3 (.00464) (2.23) [-.334; .369] <.0357>
XD/DC ; PHI/DA ; THE/DB .0964 (0) (-.717) (1.28) (-3.14) <.279>

XD/DC ; PHI/DA ; PSI/DP -.248 (.00118) (-.528) [-.00398; 9.08] <.0128>
YD/DP ; PHI/DA ; THE/DB -1.67 (.0245) (.226) [.185; .643] <-.00382>
ZD/DB ; PHI/DA ; PSI/DP 2.28 (.00429) (-.349) [.231; 4.11] <-.0575>

ZD/DC ; PHI/DA ; THE/DB ; PSI/DP -18.6 [.807; .0135] <-.00341>
XD/DC ; PHI/DA ; THE/DB ; PSI/DP -.342 (.00228) (-1.43) <.00111>

TABLE II-5 CONTINUED
OH-6A TRANSFER FUNCTION FACTORS

CASE 4 HOVER

DENOMINATOR: (0) (.229) (.821) (2.01) (4.93) [.00106; .408] [-.0283; .512] <.0814>
 HD YD PD R P PL

CONTROL NUMERATORS:

```

PHI/DA      1.28 (0) (.0216) (.232) (.812) (1.87) [ -.00771; .395 ] <.00153>
THE/DB     - .737 (0) (.0164) (.249) (.892) (4.96) [ -.0338; .554 ] <-.00409>
PSI/DP     -2.56 (.357) (2.00) (4.83) [ -.190; .476 ] [ .0541; .527 ] <-.555>

PHI/DB     .190 (0) (.0203) (.316) (.915) (6.25) [ -.144; .294 ] <.000603>
PHI/DP     - .152 (0) (.0103) (.372) (-1.88) (2.16) [ -.202; .305 ] <.000223>
PHI/DC     .148 (0) (-.207) (2.50) [ .897; .274 ] [ -.225; .418 ] <-.00100>

THE/DA     .662 (0) (.115) (-.177) (.888) [ .914; .136 ] <-.000223>
THE/DP     - .146 (0) (.0224) (.269) (2.47) (5.79) [ -.0478; .551 ] <-.00382>
THE/DC     - .0278 (0) (.0198) (.206) (4.21) (-4.90) [ -.0780; .533 ] <.000664>

PSI/DA     .196 (.0178) (1.22) (1.49) [ .365; .260 ] [ -.917; 1.63 ] <.00114>
PSI/DB     .0887 (.418) (-1.94) (5.50) [ -.0236; .578 ] [ .485; 1.65 ] <-.359>
PSI/DC     .954 (.161) (1.95) (4.77) [ -.185; .435 ] [ -.00342; .535 ] <.0775>

XD/DB      .859 (0) (.250) (.893) (4.98) [ -.0336; .554 ] [ .0522; 5.25 ] <8.06>
YD/DA      .514 (0) (.231) (.807) (1.89) [ -.00771; .395 ] [ .0987; 8.91 ] <2.25>
ZD/DC      -7.33 (0) (.437) (2.01) (4.92) [ .121; .396 ] [ -.0327; .509 ] <-1.29>

XD/DC      - .194 (0) (.206) (3.97) [ -.0779; .534 ] [ -.484; 4.89 ] <-1.08>
YD/DP      1.53 (0) (.326) (2.07) (5.76) [ -.148; .320 ] [ -.328; 1.20 ] <.873>
ZD/DB      - .0430 (0) (1.55) (2.50) (5.51) [ -.0592; .522 ] [ -.392; 3.46 ] <-2.99>

PHI/DA ; THE/DB    - .956 (0) (.0161) (.0216) (.253) (.892) <-.750E-4>
PHI/DA ; PSI/DP   -3.27 (.0216) (.358) (1.85) [ -.125; .471 ] <-.0104>
THE/DB ; PSI/DP   1.90 (.0115) (.336) (4.87) [ -.0306; .556 ] <.0110>

PHI/DB ; PSI/DP   - .474 (.0305) (.362) (6.41) [ -.0661; .306 ] <-.00313>
PHI/DP ; THE/DB   .140 (0) (.0178) (.540) [ -.216; .113 ] <.171E-4>
PHI/DC ; THE/DB   - .104 (0) (.0163) (-.117) [ .955; .478 ] <.454E-4>

THE/DA ; PSI/DP   -1.67 (-.269) (.506) [ .790; .0831 ] <.00157>
THE/DP ; PHI/DA   - .181 (0) (.274) (2.97) [ .996; .0220 ] <-.709E-4>
THE/DC ; PHI/DA   - .0424 (0) (.0114) (.0291) (.208) (-3.31) <.971E-5>

PSI/DA ; THE/DB   - .149 (.880) [ .680; .0677 ] [ -.950; 1.32 ] <-.00104>
PSI/DB ; PHI/DA   .0767 (.0216) (.406) (-2.00) [ .592; 2.24 ] <-.00674>
PSI/DC ; THE/DB   - .701 (.0100) (.0906) (4.80) [ -.0341; .561 ] <-.000962>

PSI/DC ; PHI/DA   1.20 (.0216) (.165) (1.83) [ -.174; .435 ] <.00147>
XD/DB ; PHI/DA   1.11 (0) (.0216) (.253) (.893) [ .0601; 5.26 ] <.151>
XD/DB ; PSI/DP   -2.20 (.335) (4.89) [ -.0307; .556 ] [ .0517; 5.27 ] <-30.9>

YD/DA ; THE/DB   - .381 (0) (.0160) (.252) (.892) [ .0976; 8.95 ] <-.110>
YD/DA ; PSI/DP   -1.62 (.355) (1.86) [ -.123; .471 ] [ .0521; 8.04 ] <-15.3>
ZD/DC ; PHI/DA   -9.42 (0) (.0269) (.437) (1.87) [ .0943; .375 ] <-.0292>

ZD/DC ; THE/DB   5.40 (0) (.0172) (.617) (4.95) [ -.0312; .559 ] <.0891>
ZD/DC ; PSI/DP   18.9 (2.01) (4.83) [ -.183; .480 ] [ .0598; .535 ] <12.0>
XD/DC ; PHI/DA   .0104 (0) (.0204) (.208) (-4.41) [ -.396; 9.92 ] <-0.192>

XD/DC ; THE/DB   .0203 (0) (.200) (-1.35) (6.46) [ -.0280; .571 ] <-.0115>
XD/DC ; PSI/DP   .759 (-.207) (4.47) (-8.98) [ -.100; .585 ] <2.16>
YD/DP ; PHI/DA   2.04 (0) (.0906) (.141) (1.84) [ -.0120; .460 ] <.0102>

YD/DP ; THE/DB   -1.12 (0) (-.00611) (.365) (5.76) [ -.818; .480 ] <.00333>
ZD/DB ; PHI/DA   -.0523 (0) (.0217) (1.50) (3.68) [ -.360; 2.91 ] <-.0530>
ZD/DB ; PSI/DP   .121 (4.47) (5.53) [ -.0281; .496 ] [ -.249; 2.68 ] <5.26>

PHI/DA ; THE/DB ; PSI/DP   2.44 (.0109) (.0218) (.340) <.000198>
PHI/DC ; THE/DB ; PSI/DP   .135 (.0114) (-.127) (.645) <-.000127>
THE/DC ; PHI/DA ; PSI/DP   .276 (0) (.0329) (-.192) <-.00174>

```

TABLE II-5 CONTINUED
OH-6A TRANSFER FUNCTION FACTORS

CASE 4 HOVER

CONTROL NUMERATORS CONCLUDED:

PSI/DC ; PHI/DA ; THE/DB -0.888 (.0952) [.828; .0186] <-.292E-4>

XD/DB ; PHI/DA ; PSI/DP -2.82 (.0216) (.339) [.0592; 5.28] <-.575>
 YD/DA ; THE/DB ; PSI/DP 1.21 (.0112) (.337) [.0535; 8.06] <.296>
 ZD/DC ; PHI/DA ; THE/DB 7.01 (0) (.0148) (.0276) (.618) <.00177>

ZD/DC ; THE/DB ; PSI/DP -14.0 (.0116) (4.87) [-.0316; .560] <-.248>
 ZD/DC ; PHI/DA ; PSI/DP 24.1 (.0256) (1.86) [-.112; .476] <.260>
 XD/DC ; PHI/DA ; THE/DB .0289 (0) (.00111) (.220) (-1.83) <-.130E-4>

XD/DC ; PHI/DA ; PSI/DP -8.78 (.0180) (-.208) <.0328>
 XD/DC ; THE/DB ; PSI/DP -1.197 (-.0214) (5.09) [-.0264; .561] <.00675>
 YD/DP ; PHI/DA ; THE/DB -1.53 (0) (.0152) (.0960) (.179) <-.000399>

ZD/DB ; PHI/DA ; PSI/DP .142 (.0205) (5.10) [-.189; 2.36] <.0825>

ZD/DC ; PHI/DA ; THE/DB ; PSI/DP -18.0 (.0105) (.0261) <-.30493>
 XD/DC ; PHI/DA ; THE/DB ; PSI/DP -1.254 [-.168; .0538] <-.000735>

GUST NUMERATORS:

PHI/UG .0116 (0) (0) (0) (-.0155) (.101) (.610) <-.111E-4>
 THE/UG -0.0111 (0) (0) (.223) (.690) (5.02) [-.0240; .544] <-.00253>
 PSI/UG .0260 (0) (0) (-.393) (1.76) (5.07) [-.0200; .538] <.0264>

PHI/VG .0462 (0) (0) (.227) (.847) (1.82) [-.00596; .395] <.00253>
 THE/VG .0298 (0) (0) (0) (.0146) (.262) (.642) <.734E-4>
 PSI/VG -0.0499 (0) (0) (-.388) (1.76) [.678; .403] <.00553>

PHI/WG -0.00143 (0) (0) (5.07) [.355; .346] [-.428; .371] <-.000120>
 THE/WG .00449 (0) (0) (4.93) [.815; .0173] [-.0233; .545] <.196E-5>
 PSI/WG -0.0321 (0) (1.90) (4.93) [-.0787; .372] [-.0144; .522] <-.0114>

PHI/PG 4.96 (0) (.0254) (.237) (.813) (1.98) [-.0118; .386] <.00717>
 THE/PG -0.322 (0) (.0147) (.263) (.652) (1.40) [-.503; 1.44] <-.00236>
 PSI/PG 1.12 (-.351) (1.19) (1.87) [-.661; .400] [-.425; 1.12] <-.176>

PHI/QG 1.15 (0) (-.0150) (.0935) (.506) (1.09) [-.381; .632] <-.000356>
 THE/QG 1.77 (0) (.0191) (.248) (.898) (5.27) [-.0354; .529] <.0111>
 PSI/QG .124 (.397) [-.0342; .537] [.669; 1.90] [-.915; 4.07] <.849>

PHI/RG .108 (0) (0) (-.106) (.388) (3.12) [-.0862; .353] <.00172>
 THE/RG -0.111 (0) (0) (-.0209) (.275) (4.74) [-.0569; .578] <-.00100>
 PSI/RG .830 (.278) (1.91) (4.83) [-.0797; .367] [-.0133; .534] <.0814>

XD/UG .0269 (0) (.222) (.681) (5.02) [-.0252; .544] [.194; 3.67] <.0814>
 ZD/UG .0519 (0) (0) (0) (1.50) (1.97) (4.89) [-.0419; .518] <.201>
 YD/VG .0477 (0) (.228) (.868) (1.81) [-.00673; .396] [.327; 5.52] <.0814>

XD/WG -0.00236 (0) (0) (.00675) (4.93) [-.0226; .545] [-.0740; 7.82] <-.00143>
 ZD/WG .335 (0) (.546) (2.01) (4.93) [.0300; .415] [-.0293; .510] <.0814>

PHI/UG ; THE/DB .00178 (0) (0) (.0203) (.384) (1.35) <.187E-4>
 PHI/UG ; PSI/DP -0.0314 (0) (0) (0) (-.354) <-.0111>
 THE/UG ; PHI/DA -0.0143 (0) (0) (.0216) (.225) (.683) <-.475E-4>

THE/UG ; PSI/DP .0322 (0) (.363) (5.00) [-.0281; .543] <.0173>
 PSI/UG ; PHI/DA .0333 (0) (0) (.0216) (.404) (1.70) <.000495>
 PSI/UG ; THE/DB -0.0182 (0) (.406) (5.05) [-.0319; .547] <-.0112>

PHI/VG ; THE/DB -0.0346 (0) (0) (.0164) (.249) (.901) <-.000127>
 PHI/VG ; PSI/DP -0.119 (0) (.357) (1.81) [-.125; .474] <-.0173>
 THE/VG ; PHI/DA .00167 (0) (0) (.0792) [-.583; .229] <.694E-5>

THE/VG ; PSI/DP -0.0817 (0) (0) (.0105) (.282) <-.000241>
 PSI/VG ; PHI/DA -0.00927 (0) (.0180) (1.79) [-.0168; .344] <-.353E-4>
 PSI/VG ; THE/DB .0345 (0) (0) (.00868) (.155) <.464E-4>

TABLE II-5 CONTINUED
OH-6A TRANSFER FUNCTION FACTORS

CASE 4 HOVER

GUST NUMERATORS CONTINUED:

PHI/WG ; THE/DB	.000204	(0)	(0)	(.0164)	[-.826; 1.34]	<.600E-5>	
PHI/WG ; PSI/DP	.0185	(0)	(.429)	[-.343; .327]	<.000848>		
THE/WG ; PHI/DA	.00584	(0)	(0)	(-.0244)	[.816; .0452]	<-.292E-6>	
THE/WG ; PSI/DP	-.0162	(0)	(.0227)	(5.00)	[-.0433; .544]	<-.000546>	
PHI/WG ; PHI/DA	-.0410	(0)	(.0217)	(1.80)	[-.0764; .364]	<-.000211>	
PSI/WG ; THE/DB	.0233	(0)	(.0165)	(4.95)	[-.0347; .553]	<.000579>	
PHI/PG ; THE/DB	-3.59	(0)	(.0164)	(.0259)	(.252)	(.889)	<-.000342>
PHI/PG ; PSI/DP	-12.5	(.0259)	(.358)	(1.97)	[-.117; .460]	<-.0484>	
THE/PG ; PHI/DA	-.639	(0)	(.00827)	(.0229)	(.250)	(.817)	<-.246E-4>
THE/PG ; PSI/DP	.989	(.0106)	(.279)	(1.45)	[-.473; 1.36]	<.00787>	
PSI/PG ; PHI/DA	.465	(.0216)	(.489)	(-.636)	[.999; 1.04]	<-.00339>	
PSI/PG ; THE/DB	-.796	(.00894)	(.151)	(1.26)	[-.432; 1.08]	<-.00160>	
PHI/QG ; THE/DB	-1.19	(0)	(.252)	(.889)	[.983; .0156]	<-.646E-4>	
PHI/QG ; PSI/DP	-2.94	(0)	(.352)	(.709)	[-.490; .701]	<-.360>	
THE/QG ; PHI/DA	2.22	(0)	(.0183)	(.0225)	(.253)	(.899)	<.000208>
THE/QG ; PSI/DP	-4.51	(.0164)	(.342)	(5.21)	[-.0291; .524]	<-.0361>	
PSI/QG ; PHI/DA	-.0664	(.0216)	(.403)	(-3.26)	[.445; 2.91]	<.0159>	
PSI/QG ; THE/DB	-.248	(-.0988)	(.187)	(1.23)	[-.545; 1.07]	<.00650>	
PHI/RG ; THE/DB	-.0587	(0)	(0)	(.0163)	(.161)	(.513)	<-.789E-4>
PHI/RG ; PSI/DP	-.151	(.00686)	(.371)	(4.94)	[-.0784; .342]	<-.000223>	
THE/RG ; PHI/DA	-.147	(0)	(0)	(.0119)	(.0288)	(.280)	<-.141E-4>
THE/RG ; PSI/DP	.405	(.0225)	(.275)	(4.83)	[-.0338; .562]	<.00382>	
PSI/RG ; PHI/DA	1.05	(.0216)	(.282)	(1.80)	[-.0770; .365]	<.00153>	
PSI/RG ; THE/DB	-.602	(.0163)	(.276)	(4.85)	[-.0311; .557]	<-.00409>	
XD/UG ; PHI/DA	.0346	(0)	(.0216)	(.225)	(.675)	[-.190; 3.67]	<.00153>
XD/UG ; THE/DB	-.0103	(0)	(.257)	(1.00)	(5.03)	[-.0310; .554]	<-.00409>
XD/UG ; PSI/DP	-.0681	(.364)	(5.00)	[-.0292; .543]	[.144; 3.90]	<-.555>	
ZD/UG ; PHI/DA	.0667	(0)	(0)	(.0210)	(1.52)	(1.75)	<.00371>
ZD/UG ; THE/DB	-.0387	(0)	(0)	(1.51)	(4.94)	[-.0331; .567]	<-.0929>
ZD/UG ; PSI/DP	-.130	(0)	(0)	(1.82)	(4.82)	[.0225; .478]	<-.260>
YD/VG ; PHI/DA	.0375	(0)	(.226)	(.630)	(1.83)	[-.0119; .396]	<.00153>
YD/VG ; THE/DB	-.0353	(0)	(.0164)	(.249)	(.925)	[-.316; 5.55]	<-.00409>
YD/VG ; PSI/DP	-.122	(.359)	(1.80)	[-.125; .474]	[.264; 5.60]	<-.555>	
XD/WG ; PHI/DA	-.00308	(0)	(0)	(-.0125)	(.0412)	[-.0478; 7.81]	<.965E-4>
XD/WG ; THE/DB	-.00212	(0)	(0)	(.0376)	(5.03)	[-.0410; .554]	<-.000123>
XD/WG ; PSI/DP	.510	(0)	(5.12)	[-.0425; .544]	<.773>		
ZD/WG ; PHI/DA	.430	(0)	(.0218)	(.542)	(1.87)	[.0191; .400]	<.00153>
ZD/WG ; THE/DB	-.247	(0)	(.0164)	(.665)	(4.96)	[-.0348; .554]	<-.00409>
ZD/WG ; PSI/DP	-.863	(2.01)	(4.83)	[-.179; .482]	[.0505; .534]	<-.555>	
XD/UG ; ZD/DC	-.198	(0)	(.309)	(4.99)	[-.0217; .554]	[.196; 3.72]	<-1.29>
YD/VG ; ZD/DC	-.323	(0)	(.427)	(1.86)	[-.0923; .381]	[.306; 5.88]	<-1.29>
PHI/UG ; THE/DB ; PSI/DP	-.00805	(0)	(.0306)	(.395)	<-.972E-4>		
THE/UG ; PHI/DA ; PSI/DP	.0409	(0)	(.0216)	(.366)	<.000323>		
PSI/UG ; PHI/DA ; THE/DB	-.0239	(0)	(.0216)	(.405)	<-.000209>		
PHI/VG ; THE/DB ; PSI/DP	.0894	(0)	(.0115)	(.334)	<.000347>		
THE/VG ; PHI/DA ; PSI/DP	-.00556	(0)	[.812; .0938]	<-.489E-4>			
PSI/VG ; PHI/DA ; THE/DB	.00680	(0)	[.680; .0690]	<.323E-4>			
PHI/WG ; THE/DB ; PSI/DP	-.00389	(0)	(.0107)	(-.329)	<-.138E-4>		
THE/WG ; PHI/DA ; PSI/DP	-.0206	(0)	(.0124)	(.0307)	<-.784E-5>		
PSI/WG ; PHI/DA ; THE/DB	.0301	(0)	(.0118)	(.0256)	<.910E-5>		

TABLE II-5 CONTINUED
OH-6A TRANSFER FUNCTION FACTORS

CASE 4 HOVER

GUST NUMERATORS CONCLUDED:

PHI/PG ; THE/DB ; PSI/DP	9.12	(.0115)	(.0256)	(.340)	<.000917>
THE/PG ; PHI/DA ; PSI/DP	1.69	(0)	(.0230)	(.338)	<.0131>
PSI/PG ; PHI/DA ; THE/DB	-.308	(.0238)	(-.0242)	(.327)	<.578E-4>
PHI/QG ; THE/DB ; PSI/DP	3.01	(.340)	[.904 ; .0140]	<.000201>	
THE/QG ; PHI/DA ; PSI/DP	-5.65	(.0153)	(.0230)	(.340)	<-.000677>
PSI/QG ; PHI/DA ; THE/DB	-.0831	(.0206)	(-.234)	(.338)	<.000136>
PHI/RG ; THE/DB ; PSI/DP	.0373	(.0164)	(-.0452)	(.617)	<-.171E-4>
THE/RG ; PHI/DA ; PSI/DP	.521	(.281)	[.993 ; .0220]	<.709E-4>	
PSI/RG ; PHI/DA ; THE/DB	-.769	(.0163)	(.0213)	(.281)	<-.750E-4>
XD/UG ; PHI/DA ; THE/DB	-.0134	(0)	(.0217)	(.259)	(.998) <-.750E-4>
XD/UG ; PHI/DA ; PSI/DP	-.0866	(.0216)	(.366)	[.142 ; 3.90]	<-.0104>
XD/UG ; THE/DB ; PSI/DP	.0229	(.311)	(5.00)	[-.0278 ; .557]	<.0110>
ZD/UG ; PHI/DA ; THE/DB	-.0502	(0)	(0)	(.0217)	(1.51) <-.00165>
ZD/UG ; PHI/DA ; PSI/DP	-.165	(0)	(0)	(.0172)	(1.71) <-.00486>
ZD/UG ; THE/DB ; PSI/DP	.0980	(0)	(4.87)	[-.0391 ; .585]	<.163>
YD/VG ; PHI/DA ; THE/DB	-.0278	(0)	(.0161)	(.243)	(.689) <-.750E-4>
YD/VG ; PHI/DA ; PSI/DP	-.0805	(.311)	(1.84)	[-.122 ; .476]	<-.0104>
YD/VG ; THE/DB ; PSI/DP	.0912	(.0115)	(.335)	[.255 ; 5.61]	<.0110>
XD/WG ; PHI/DA ; THE/DB	-.00275	(0)	(0)	(-.0644)	(.135) <.240E-4>
XD/WG ; PHI/DA ; PSI/DP	.663	(0)	(.0203)	<.0135>	
XD/WG ; THE/DB ; PSI/DP	.0103	(0)	(4.73)	[-.0348 ; .556]	<.0150>
ZD/WG ; PHI/DA ; THE/DB	-.320	(0)	(.0160)	(.0220)	(.667) <-.750E-4>
ZD/WG ; PHI/DA ; PSI/DP	-1.10	(.0218)	(1.87)	[-.113 ; .482]	<-.0104>
ZD/WG ; THE/DB ; PSI/DP	.640	(.0115)	(4.88)	[-.0339 ; .555]	<.0110>
XD/UG ; ZD/DC ; PHI/DA	-.254	(0)	(.0269)	(.309)	[.192 ; 3.72] <-.0292>
XD/UG ; ZD/DC ; THE/DB	.0745	(0)	(.765)	(4.99)	[-.0301 ; .559] <.0891>
XD/UG ; ZD/DC ; PSI/DP	.501	(4.98)	[-.0284 ; .550]	[.139 ; 3.99]	<12.0>
YD/VG ; ZD/DC ; PHI/DA	-.236	(0)	(.483)	(1.85)	[.0584 ; .373] <-.0292>
YD/VG ; ZD/DC ; THE/DB	.239	(0)	(.0172)	(.621)	[.296 ; 5.90] <.0891>
YD/VG ; ZD/DC ; PSI/DP	.919	(1.83)	[-.113 ; .473]	[.266 ; 5.59]	<12.0>
XD/UG ; PHI/DA ; THE/DB ; PSI/DP	.0294	(.0214)	(.315)	<.000198>	
ZD/UG ; PHI/DA ; THE/DB ; PSI/DP	.125	(0)	(.0205)	<.00257>	
YD/VG ; PHI/DA ; THE/DB ; PSI/DP	.0602	(.0111)	(.298)	<.000198>	
XD/WG ; PHI/DA ; THE/DB ; PSI/DP	.0131	(0)	(.0134)	<.000176>	
ZD/WG ; PHI/DA ; THE/DB ; PSI/DP	.820	(.0109)	(.0221)	<.000198>	
XD/UG ; ZD/DC ; PHI/DA ; THE/DB	.0968	(0)	(.0240)	(.764)	<.00177>
YD/VG ; ZD/DC ; PHI/DA ; THE/DB	.175	(0)	(.0161)	(.630)	<.00177>
YD/VG ; ZD/DC ; PHI/DA ; PSI/DP	.609	(1.85)	[-.114 ; .480]	<.260>	
XD/WG ; ZD/DC ; PHI/DA ; THE/DB	.0105	(0)	(.00117)	(1.06)	<.130E-4>
XD/UG ; ZD/DC ; PHI/DA ; THE/DB ; PSI/DP	-.204	(.0242)	<-.00493>		
YD/VG ; ZD/DC ; PHI/DA ; THE/DB ; PSI/DP	-.455	(.0108)	<-.00493>		
XD/WG ; ZD/DC ; PHI/DA ; THE/DB ; PSI/DP	-.0115	(-.0637)	<.000735>		

TABLE II-5 CONTINUED
OH-6A TRANSFER FUNCTION FACTORS

CASE 5 20KT

DENOMINATOR: (0) (.256) (.499) (2.02) (5.25) [-.0913; .450] [.325; 1.10] <.330>

CONTROL NUMERATORS:

PHI/DA	1.27	(0)	(.489)	(1.93)	(-1.141; .480)	[.511; 1.07]	<.318>
THE/DB	-.734	(0)	(.00822)	(.256)	(.423)	(5.27)	[-.328; 1.09] <-.00412>
PSI/DP	-2.60	(.490)	(2.03)	(5.09)	(-.169; .495)	[.0561; .517]	<-.864>
PHI/DB	.182	(0)	(.270)	(-.414)	(1.20)	(6.31)	[.285; 1.15] <-.204>
PHI/DP	-.139	(0)	(.489)	(2.01)	(-.0929; .500)	[-.108; 5.16]	<-.908>
PHI/DC	.152	(0)	(.573)	(1.93)	(-.121; .540)	[.0385; 2.78]	<.378>
THE/DA	.638	(0)	(.0233)	(.286)	(.471)	[.316; .925]	<.00172>
THE/DP	-.0838	(0)	(.0234)	(.313)	(.424)	(7.48)	[.884; 1.58] <-.00486>
THE/DC	.0891	(0)	(.00596)	(.272)	(.726)	(6.22)	[.554; 1.21] <.000958>
PSI/DA	.176	(.487)	(-.0897; .464)	(.968; 1.68)	(-.862; 2.40)	<.300>	
PSI/DB	.0665	(.271)	(-1.32)	(5.72)	(-.0224; .709)	[.267; 1.69]	<-.196>
PSI/DC	.742	(.568)	(2.07)	(4.90)	(-.182; .522)	[.0466; .558]	<.364>
XD/DB	.848	(0)	(.257)	(.433)	(5.28)	[.328; 1.09]	[.0446; 5.25] <16.4>
YD/DA	.525	(.490)	(1.93)	(-.138; .483)	(.493; 1.07)	[.0902; 8.77]	<10.1>
ZD/DC	-6.98	(0)	(.150)	(1.94)	(5.25)	[.340; .372]	[.220; 1.06] <-1.67>
XD/DC	-.0948	(0)	(.293)	(.726)	(6.74)	[.568; 1.18]	[.0887; 5.35] <-5.43>
YD/DP	1.55	(.490)	(2.01)	(-2.35)	(6.35)	(-.0894; .500)	[.294; 2.26] <-29.2>
ZD/DB	.676	(0)	(.257)	(-.446)	(5.25)	(-.339; 1.09)	[.258; 4.07] <-8.07>
PHI/DA ; THE/DB	-.942	(0)	(.00664)	(.436)	(-.521; 1.03)	<-.00291>	
PHI/DA ; PSI/DP	-3.29	(.0110)	(.489)	(1.91)	(-.106; .498)	<-.00835>	
THE/DB ; PSI/DP	1.92	(.00666)	(.423)	(5.13)	(-.0258; .534)	<.00790>	
PHI/DB ; PSI/DP	-.465	(.0239)	(.631)	(6.48)	(-.148; .345)	<-.00540>	
PHI/DP ; THE/DB	.117	(0)	(.00667)	(.423)	(-.0322; .501)	<.00833>	
PHI/DC ; THE/DB	-.128	(0)	(.00869)	(.509)	(.189; 2.70)	<-.00413>	
THE/DA ; PSI/DP	-1.61	(.0224)	(.482)	(-.515; .0674)	<-.790E-4>		
THE/DP ; PHI/DA	-.101	(0)	(-.00634)	(.0226)	(.490)	(5.08) <.360E-4>	
THE/DC ; PHI/DA	.107	(0)	(-.0142)	(1.91)	[.824; .600]	<-.00104>	
PSI/DA ; THE/DB	-.132	(.00662)	(.438)	(1.32)	(-.839; 2.32)	<-.00272>	
PSI/DB ; PHI/DA	.0525	(.0151)	(.355)	(-1.63)	[.414; 2.87]	<-.00377>	
PSI/DC ; THE/DB	-.551	(.00869)	(.500)	(4.96)	(-.0368; .579)	<-.00398>	
PSI/DC ; PHI/DA	.918	(.0281)	(.556)	(1.93)	(-.127; .532)	<.00786>	
XD/DB ; PHI/DA	1.08	(0)	(.443)	[.521; 1.03]	[.0491; 5.28]	<14.2>	
XD/DB ; PSI/DP	-2.20	(.430)	(5.14)	(-.0254; .534)	[.0445; 5.26]	<-38.5>	
YD/DA ; THE/DB	-.390	(.00661)	(.435)	[.502; 1.03]	[.0927; 8.79]	<-.0919>	
YD/DA ; PSI/DP	-1.64	(.490)	(1.90)	(-.102; .499)	[.0387; 8.01]	<-24.3>	
ZD/DC ; PHI/DA	-8.89	(0)	(1.93)	[.00503; .399]	[.410; 1.04]	<-2.97>	
ZD/DC ; THE/DB	5.07	(0)	(.00682)	(.231)	(5.25)	[.277; 1.03] <.0442>	
ZD/DC ; PSI/DP	18.2	(1.95)	(5.10)	(-.135; .480)	[.141; .529]	<11.7>	
XD/DC ; PHI/DA	-.121	(0)	(1.91)	[.835; .581]	[.0664; 5.39]	<-2.25>	
XD/DC ; THE/DB	-.00597	(0)	(.0573)	(.726)	(-8.61)	[.525; 3.07] <.0202>	
XD/DC ; PSI/DP	.285	(.791)	(5.92)	(-.0364; .486)	[.156; 4.35]	<5.98>	
YD/DP ; PHI/DA	2.05	(.485)	(.693)	(-.801)	(1.95)	(-.0306; .512)	<-.282>
YD/DP ; THE/DB	-1.13	(.00665)	(.423)	(-2.55)	(6.35)	[.323; 2.27] <.267>	
ZD/DP ; PHI/DA	.845	(0)	(-.446)	[.553; 1.05]	[.213; 4.10]	<-7.04>	
ZD/DB ; PSI/DP	-1.75	(-.415)	(5.11)	(-.0426; .527)	[.239; 4.08]	<17.2>	
PHI/DA ; THE/DB ; PSI/DP	2.44	(.00672)	(.0109)	(.429)	<.768E-4>		
PHI/DC ; THE/DB ; PSI/DP	.245	(.00766)	(-.0882)	(.798)	<-.000132>		
THE/DC ; PHI/DA ; PSI/DP	-.203	(.0108)	(-.0149)	(.810)	<.265E-4>		

TABLE II-5 CONTINUED
OH-6A TRANSFER FUNCTION FACTORS

CASE 5 20KT

CONTROL NUMERATORS CONCLUDED:

PSI/DC ; PHI/DA ; THE/DB -0.684 (.00782) (.0327) (.482) <-.843E-4>

XD/DB ; PHI/DA ; PSI/DP -2.78 (.0110) (.435) [.0487; 5.29] <-.372>
YD/DA ; THE/DB ; PSI/DP 1.22 (.00667) (.426) [.0426; 8.01] <.223>
ZD/DC ; PHI/DA ; THE/DB 6.52 (0) (0) [.487; .941] <5.77>

ZD/DC ; THE/DB ; PSI/DP -13.3 (.00249) (5.12) [-.0291; .543] <-.0500>
XD/DC ; PHI/DA ; PSI/DP 23.0 (.0157) (1.85) [.00914; .482] <.155>
XD/DC ; PHI/DA ; THE/DB .0205 (0) (.982) (3.34) <.0671>

XD/DC ; PHI/DA ; PSI/DP .360 (.0111) (.790) [.153; 4.29] <.0583>
XD/DC ; THE/DB ; PSI/DP -0.0665 (1.54) (6.75) [-.0456; .513] <-.182>
YD/DP ; PHI/DA ; THE/DB -1.52 (.00669) (.353) (-.825) (.876) <.00259>

ZD/DB ; PHI/DA ; PSI/DP -2.18 (.0103) (-.394) [.205; 4.09] <.148>

ZD/DC ; PHI/DA ; THE/DB ; PSI/DP -16.9 (.00442) (.0128) <-.000959>
XD/DC ; PHI/DA ; THE/DB ; PSI/DP -0.0947 (.0107) (1.69) <-.00172>

GUST NUMERATORS:

PHI/UG .0133 (0) (0) (.575) [.685; 2.27] <.0397>
THE/UG -0.0145 (0) (0) (.255) (.479) (5.30) [.278; 1.04] <-.0103>
PSI/UG -0.223 (0) (0) (.575) (1.67) (5.36) [-.0459; .578] <.0385>

PHI/VG .0441 (0) (0) (-.607) (1.02) (1.86) [-.0622; .450] <.0103>
THE/VG .0160 (0) (0) (.141) (-.258) (.363) <-.000212>
PSI/VG -0.0249 (0) (0) (.541) (1.94) (7.14) [-.0952; .447] <-.0372>

PHI/WG .00515 (0) (0) (1.77) [-.155; .649] [.0820; 1.68] <.0108>
THE/WG .00368 (0) (0) (-.0103) (.265) (5.87) [.376; 1.13] <-.754E-4>
PSI/WG .00793 (0) (2.38) (4.14) [-.147; .541] [.0797; .689] <.0108>

PHI/PG 5.21 (0) (.529) (2.00) [-.0929; .441] [.472; 1.09] <1.28>
THE/PG -0.305 (0) (.137) (-.218) (.359) (1.34) [-.191; 1.25] <.00682>
PSI/PG 1.15 (.539) [-.0968; .447] [-.460; 1.69] [.993; 1.84] <1.21>

PHI/QG 1.15 (0) (.332) (1.47) [-.680; .955] [.387; .733] <.912>
THE/QG 1.88 (0) (.0140) (.259) (.422) (5.55) [.330; 1.08] <.0186>
PSI/QG .124 (.333) (-3.10) (-4.81) [-.0695; .581] [.654; 2.16] <.872>

PHI/RG -0.105 (0) (-.543) (2.28) [-.0937; .444] [.182; 3.72] <.347>
THE/RG -0.121 (0) (0) (.0989) (.362) (4.93) [-.0110; .621] <-.00822>
PSI/RG 1.07 (.540) (1.95) (5.10) [-.0919; .442] [-.0307; .541] <.330>

XD/UG .0214 (0) (.253) (.482) (5.32) [.272; 1.05] [.104; 4.66] <.330>
ZD/UG .201 (0) (0) (.233) (5.25) [.497; 1.08] [.819; 1.10] <.346>
YD/VG .0516 (0) (.592) (1.20) (1.77) [-.0616; .450] [.340; 5.02] <.330>

XD/WG -0.0106 (0) (0) (.279) (5.80) [.385; 1.13] [.176; 3.34] <-.246>
ZD/WG .426 (0) (.248) (2.12) (5.24) [-.102; .483] [.338; 1.10] <.330>

PHI/UG ; THE/DB .00252 (0) (0) (.326) (-1.95) (3.94) <-.00633>
PHI/UG ; PSI/DP -0.0365 (0) (0) (-.0933) (.571) <.00195>
THE/UG ; PHI/DA -0.0185 (0) (0) (.476) [-.425; 1.06] <-.00989>

THE/UG ; PSI/DP .0397 (0) (.472) (5.22) [-.0197; .524] <.0269>
PSI/UG ; PHI/DA .0283 (0) (0) (.0402) (.577) (1.60) <.00105>
PSI/UG ; THE/DB -0.0154 (0) (-.330) (5.34) [.0421; .474] <-.00609>

PHI/VG ; THE/DB -0.0326 (0) (0) (.00815) (.450) (1.07) <-.000128>
PHI/VG ; PSI/DP -0.118 (0) (.481) (1.90) [-.105; .499] <-.0269>
THE/VG ; PHI/DA -0.000734 (0) (0) (.0214) (.420) (8.09) <-.534E-4>

THE/VG ; PSI/DP -0.0627 (0) (0) (0) (.380) <-.0238>
PSI/VG ; PHI/DA -0.0394 (0) (.506) (1.90) [-.109; .496] <-.00932>
PSI/VG ; THE/DB .0182 (0) (0) (.00600) (.438) (7.09) <.000339>

TABLE II-5 CONTINUED
OH-6A TRANSFER FUNCTION FACTORS

CASE 5 20KT

GUST NUMERATORS CONTINUED:

PHI/WG ; THE/DB	- .00446	(0)	(0)	(.0152)	[.254; 1.63]	<-.000181>	
PHI/WG ; PSI/DP	- .0123	(0)	(-.283)	(1.40)	[-.245; .563]	<.00154>	
THE/WG ; PHI/DA	.00447	(0)	(0)	(-.0268)	[.653; 1.04]	<-.000129>	
THE/WG ; PSI/DP	- .00892	(0)	(-.0290)	(5.68)	[-.0484; .493]	<.000357>	
PSI/WG ; PHI/DA	.00918	(0)	(.0859)	(2.08)	[-.105; .624]	<.000639>	
PSI/WG ; THE/DB	- .00607	(0)	(.0148)	(4.39)	[.0441; .676]	<-.000180>	
PHI/PG ; THE/DB	-3.77	(0)	(.00605)	(.437)	[.494; 1.09]	<-.0118>	
PHI/PG ; PSI/DP	-13.4	(.0140)	(.500)	(2.00)	[-.102; .488]	<-.0447>	
THE/PG ; PHI/DA	- .613	(0)	(0)	(.434)	[.465; 1.04]	<-.289>	
THE/PG ; PSI/DP	.891	(0)	(.376)	(1.36)	[-.466; 1.30]	<.771>	
PSI/PG ; PHI/DA	.548	(-.330)	[.883; .120]	[.959; 1.21]	<-.00384>		
PSI/PG ; THE/DB	- .825	(.00602)	(.438)	(1.76)	[-.459; 1.70]	<-.0110>	
PHI/QG ; THE/DB	-1.19	(0)	(0)	(.417)	[.509; 1.07]	<-.565>	
PHI/QG ; PSI/DP	-2.99	(-.0256)	(.261)	(.969)	[-.508; .742]	<.0107>	
THE/QG ; PHI/DA	2.34	(0)	(.0122)	(.433)	[.524; 1.03]	<.0132>	
THE/QG ; PSI/DP	-4.88	(.0123)	(.422)	(5.41)	[-.0248; .512]	<-.0359>	
PSI/QG ; PHI/DA	- .0456	(.0193)	(.352)	(-2.47)	[.166; 3.98]	<.0121>	
PSI/QG ; THE/DB	- .216	(0)	(.417)	(1.56)	[-.618; 1.94]	<-.529>	
PHI/RG ; THE/DB	- .0549	(0)	(.00814)	(.439)	[.0582; 4.69]	<-.00432>	
PHI/RG ; PSI/DP	- .123	(-.0144)	(.678)	(5.68)	[-.125; .372]	<.000948>	
THE/RG ; PHI/DA	- .158	(0)	(.0215)	(.430)	[-.0101; 1.11]	<-.00180>	
THE/RG ; PSI/DP	.404	(.0215)	(.379)	(5.11)	[-.0287; .538]	<.00486>	
PSI/RG ; PHI/DA	1.35	(.0132)	(.531)	(1.85)	[-.0946; .450]	<.00352>	
PSI/RG ; THE/DB	- .780	(.00814)	(.437)	(5.12)	[-.0289; .538]	<-.00412>	
XD/UG ; PHI/DA	.0272	(0)	(.478)	[.420; 1.06]	[.102; 4.67]	<.318>	
XD/UG ; THE/DB	- .00339	(0)	(.282)	(1.33)	(5.42)	[.242; .772]	<-.00412>
XD/UG ; PSI/DP	- .0545	(.473)	(5.25)	[-.0196; .524]	[.0840; 4.82]	<-.864>	
ZD/UG ; PHI/DA	.255	(0)	(0)	[.648; .856]	[.737; 1.34]	<.334>	
ZD/UG ; THE/DB	- .137	(0)	(0)	(.261)	(5.26)	[.382; 1.16]	<-.255>
ZD/UG ; PSI/DP	- .520	(0)	(5.10)	[-.0450; .510]	[.863; 1.15]	<-.906>	
YD/VG ; PHI/DA	.0424	(0)	(1.94)	[.0645; .432]	[.735; .478]	<.00352>	
YD/VG ; THE/DB	- .0380	(0)	(.00815)	(.448)	(1.18)	[.332; 5.02]	<-.00412>
YD/VG ; PSI/DP	- .0956	(.487)	(1.88)	[-.102; .499]	[.186; 6.30]	<-.864>	
XD/WG ; PHI/DA	- .0135	(0)	(0)	[.674; 1.03]	[.171; 3.25]	<-.152>	
XD/WG ; THE/DB	.00468	(0)	(0)	(.191)	(5.69)	[.308; 1.16]	<.00681>
XD/WG ; PSI/DP	.0281	(0)	(5.58)	[-.0497; .493]	[.211; 3.23]	<.398>	
ZD/WG ; PHI/DA	.542	(0)	(2.01)	[-.145; .507]	[.528; 1.07]	<.318>	
ZD/WG ; THE/DB	- .316	(0)	(.00816)	(.252)	(5.28)	[.338; 1.10]	<-.00412>
ZD/WG ; PSI/DP	-1.11	(2.13)	(5.09)	[-.167; .507]	[.0300; .529]	<-.864>	
XD/UG ; ZD/DC	- .130	(0)	(.176)	(5.12)	[.118; .823]	[.120; 4.57]	<-1.67>
YD/VG ; ZD/DC	- .343	(0)	(.304)	(1.95)	[-.547; .542]	[.328; 5.29]	<-1.67>
PHI/UG ; THE/DB ; PSI/DP	- .00905	(0)	(.0240)	(.771)	<-.000168>		
THE/UG ; PHI/DA ; PSI/DP	.0501	(0)	(.0110)	(.473)	<.000260>		
PSI/UG ; PHI/DA ; THE/DB	- .0202	(0)	(.0151)	(.383)	<-.000117>		
PHI/VG ; THE/DB ; PSI/DP	.0879	(0)	(.00666)	(.419)	<.000245>		
THE/VG ; PHI/DA ; PSI/DP	- .00122	(0)	(.0232)	(-.0866)	<.246E-5>		
PSI/VG ; PHI/DA ; THE/DB	.0292	(0)	(.00662)	(.438)	<.846E-4>		
PHI/WG ; THE/DB ; PSI/DP	.0107	(0)	(.00755)	(-.202)	<-.163E-4>		
THE/WG ; PHI/DA ; PSI/DP	- .0108	(0)	(.0108)	(-.0285)	<.331E-5>		
PSI/WG ; PHI/DA ; THE/DB	- .00698	(0)	(.00783)	(.135)	<-.737E-5>		

TABLE II-5 CONTINUED
OH-6A TRANSFER FUNCTION FACTORS

CASE 5 20KT

GUST NUMERATORS CONCLUDED:

PHI/PG ; THE/DB ; PSI/DP	9.70	(.00755)	(.0130)	(.430)	<.000409>	
THE/PG ; PHI/DA ; PSI/DP	1.63	(0)	(.0109)	(.423)	<.00749>	
PSI/PG ; PHI/DA ; THE/DB	-.381	(.00912)	(-.0222)	(.439)	<.338E-4>	
PHI/QG ; THE/DB ; PSI/DP	3.07	(.420)	[.642; .00991]	<.000127>		
THE/QG ; PHI/DA ; PSI/DP	-6.06	(.0113)	(.0119)	(.426)	<-.000348>	
PSI/QG ; PHI/DA ; THE/DB	-.0629	(.0342)	(-.0676)	(.312)	<.454E-4>	
PHI/RG ; THE/DB ; PSI/DP	.0187	(.0105)	(-.129)	(1.54)	<-.390E-4>	
THE/RG ; PHI/DA ; PSI/DP	.515	(.0109)	(.0215)	(.389)	<.469E-4>	
PSI/RG ; PHI/DA ; THE/DB	-.991	(.00996)	(.0124)	(.437)	<-.536E-4>	
XD/UG ; PHI/DA ; THE/DB	-.00448	(0)	(1.08)	[.561; .775]	<-.00291>	
XD/UG ; PHI/DA ; PSI/DP	-.0689	(.0110)	(.474)	[.0826; .483]	<-.00835>	
XD/UG ; THE/DB ; PSI/DP	.00655	(.802)	(5.63)	[-.0264; .517]	<.00790>	
ZD/UG ; PHI/DA ; THE/DB	-.177	(0)	(0)	[.566; 1.12]	<-.222>	
ZD/UG ; PHI/DA ; PSI/DP	-.658	(0)	(.0111)	[.830; 1.10]	<-.00876>	
ZD/UG ; THE/DB ; PSI/DP	.357	(0)	(5.12)	[-.0340; .545]	<.542>	
YD/VG ; PHI/DA ; THE/DB	-.0314	(0)	(.00913)	[.953; .432]	<-.536E-4>	
YD/VG ; PHI/DA ; PSI/DP	-.0462	(.372)	(1.92)	[-.101; .503]	<-.00835>	
YD/VG ; THE/DB ; PSI/DP	.0710	(.00666)	(.421)	[.183; 6.30]	<.00790>	
XD/WG ; PHI/DA ; THE/DB	.00623	(0)	(0)	[.483; 1.07]	<.00713>	
XD/WG ; PHI/DA ; PSI/DP	.0354	(0)	(.0112)	[.220; 3.13]	<.00391>	
XD/WG ; THE/DB ; PSI/DP	-.0131	(0)	(5.43)	[-.0339; .524]	<-.0195>	
ZD/WG ; PHI/DA ; THE/DB	-.405	(0)	(.00659)	[.532; 1.05]	<-.00291>	
ZD/WG ; PHI/DA ; PSI/DP	-1.40	(.0111)	(2.00)	[-.120; .520]	<-.00835>	
ZD/WG ; THE/DB ; PSI/DP	.823	(.00661)	(5.13)	[-.0315; .532]	<.00790>	
XD/UG ; ZD/DC ; PHI/DA	-.166	(0)	[.222; .923]	[.119; 4.58]	<-2.97>	
XD/UG ; ZD/DC ; THE/DB	.0245	(0)	(1.66)	(4.82)	[-.231; .475]	<.0442>
XD/UG ; ZD/DC ; PSI/DP	.325	(5.16)	[-.0222; .540]	[.0699; 4.89]	<11.7>	
YD/VG ; ZD/DC ; PHI/DA	-.273	(0)	(.00954)	(1.90)	[.286; .625]	<-.00193>
YD/VG ; ZD/DC ; THE/DB	.250	(0)	(.00659)	(.955)	[.319; 5.30]	<.0442>
YD/VG ; ZD/DC ; PSI/DP	.688	(1.81)	[.00869; .487]	[.192; 6.28]	<11.7>	
XD/UG ; PHI/DA ; THE/DB ; PSI/DP	.00870	(.0110)	(.802)	<.768E-4>		
ZD/UG ; PHI/DA ; THE/DB ; PSI/DP	.455	(0)	(.0103)	<.00468>		
YD/VG ; PHI/DA ; THE/DB ; PSI/DP	.0343	(.00669)	(.335)	<.768E-4>		
XD/WG ; PHI/DA ; THE/DB ; PSI/DP	-.0171	(0)	(.0107)	<-.000184>		
ZD/WG ; PHI/DA ; THE/DB ; PSI/DP	1.05	(.00668)	(.0110)	<.768E-4>		
XD/UG ; ZD/DC ; PHI/DA ; THE/DB	.0312	(0)	(.116)	(1.13)	<.00408>	
YD/VG ; ZD/DC ; PHI/DA ; THE/DB	.200	(0)	(.0117)	(.385)	<.000900>	
YD/VG ; ZD/DC ; PHI/DA ; PSI/DP	.337	(1.87)	[-.0263; .496]	<.155>		
XD/WG ; ZD/DC ; PHI/DA ; THE/DB	-.0426	(0)	[.239; 1.25]	<-.0671>		
XD/UG ; ZD/DC ; PHI/DA ; THE/DB ; PSI/DP	-.0428	(.0224)	<-.000959>			
YD/VG ; ZD/DC ; PHI/DA ; THE/DB ; PSI/DP	-.249	(.00385)	<-.000959>			
XD/WG ; ZD/DC ; PHI/DA ; THE/DB ; PSI/DP	.160	(.0108)	<.00172>			

TABLE II-5 CONTINUED
OH-6A TRANSFER FUNCTION FACTORS

CASE 7 40 KT

DENOMINATOR: (0) (.0811) (.949) (2.07) (5.57) [.00412; .347] [.212; 1.98] < .419 >

CONTROL NUMERATORS:

PHI/DA 1.27 (0) (.852) (2.11) [-.00998; .371] [.262; 1.95] < 1.19 >
THE/DB -.727 (0) (.0159) (.0807) (.640) (5.57) [.217; 2.00] < -.0133 >
PSI/DP -2.25 (.741) (2.18) (5.41) [-.241; .437] [.231; .497] < -.932 >

PHI/DB .199 (0) (.147) (-.200) (2.62) (5.15) [.170; 1.94] < -.298 >
THE/DA .603 (0) (.0176) (.0618) (.663) [.321; 1.70] < .00126 >

PHI/DA ; THE/DB -.932 (0) (.0159) (.647) [.276; 1.96] < -.0368 >
PHI/DA ; PSI/DP -2.83 (.0137) (.751) (2.14) [-.0481; .410] < -.0104 >
THE/DE ; PSI/DP 1.64 (.0147) (.626) (5.42) [-.0156; .552] < .0250 >

PHI/DB ; PSI/DP -.434 (.0279) (1.43) (6.10) [-.172; .196] < -.00404 >
PHI/DP ; THE/DB .0888 (0) (.0147) (.620) [.0943; 8.05] < .0526 >
PHI/DC ; THE/DB -.137 (0) (.0146) (1.00) [.196; 3.74] < -.0280 >

THE/DA ; PSI/DP -1.26 (.0327) (.581) (-.774) (.816) < .0151 >
THE/DP ; PHI/DA -.577 (0) (.0327) (.612) (2.76) < -.0319 >
THE/DC ; PHI/DA .216 (0) (.0260) (.815) [.378; 2.38] < .0259 >

PSI/DA ; THE/DB -.150 (.0159) (.650) (2.00) [-.524; 2.37] < -.0174 >
PSI/DB ; PHI/DA .129 (.0201) (.315) (-.531) [-.00375; 3.05] < -.00404 >
XD/DB ; PHI/DA 1.06 (0) (.631) [.277; 1.97] [.0699; 5.37] < 74.4 >

YD/DA ; THE/DB -.370 (.0159) (.646) [.256; 1.95] [.0479; 9.04] < -1.18 >
ZD/DB ; PHI/DA 1.39 (0) (-.0593) [.284; 1.99] [.246; 5.34] < -9.29 >
XD/DC ; PHI/DA -.181 (0) (.813) [.390; 2.45] [-.0615; 6.02] < -32.2 >

YD/DP ; THE/DB -.976 (.0147) (.622) (-3.26) (6.93) [.331; 2.89] < 1.69 >
ZD/DC ; PHI/DA -9.59 (0) (.162) [.964; 1.30] [.156; 1.86] < -9.08 >

PHI/DA ; THE/DB ; PSI/DP 2.08 (.00939) (.0172) (.634) < .000214 >
PHI/DC ; THE/DB ; PSI/DP .256 (.0147) (-.0515) (1.45) < -.000280 >
THE/DC ; PHI/DA ; PSI/DP -.467 (-.0115) (.0277) (.794) < .000118 >

PSI/DC ; PHI/DA ; THE/DB -.538 (.0153) (.0434) (.868) < -.000310 >
XD/DB ; PHI/DA ; PSI/DP -2.35 (.0129) (.624) [.0683; 5.38] < -.545 >
YD/DA ; THE/DB ; PSI/DP 1.04 (.0139) (.632) [.0205; 8.04] < .587 >

ZD/DC ; PHI/DA ; THE/DB 6.80 (0) (.0200) [.253; 1.88] < .483 >
ZD/DC ; PHI/DA ; PSI/DP 21.4 (.0217) (1.62) [.671; .447] < .151 >
XD/DC ; PHI/DA ; THE/DB -.0467 (0) (1.26) [.586; 3.26] < -.626 >

XD/DC ; PHI/DA ; PSI/DP .441 (-.00486) (.797) [.0132; 5.84] < -.0584 >
YD/DP ; PHI/DA ; THE/DB -1.30 (.0127) (.527) (-1.22) (1.37) < .0144 >
ZD/DB ; PHI/DA ; PSI/DP -3.10 (.0123) (-.0538) [.233; 5.36] < .0589 >

ZD/DC ; PHI/DA ; THE/DB ; PSI/DP -15.2 (.00639) (.0250) < -.00243 >
XD/DC ; PHI/DA ; THE/DB ; PSI/DP .0633 (-.0342) (2.30) < -.00498 >

TABLE II-5 CONTINUED
OH-6A TRANSFER FUNCTION FACTORS

CASE 8 60KT

DENOMINATOR: (0) (.0636) (5.72) [.0426; .287] [.985; 1.66] [.223; 2.63] <-.569>
S R P SP D

CONTROL NUMERATORS:

PHI/D _A	1.26	(0)	(1.39)	(1.86)	[.0518; .303]	[.268; 2.59]	<2.00>
THE/DB	-.742	(0)	(.0216)	(.0625)	(.734)	(5.70)	[.215; 2.68] <-.0300>
PSI/DP	-2.67	(.870)	(2.22)	(5.49)	[-.347; .395]	[.402; .500]	<-1.10>
PHI/DB	.187	(0)	(-.117)	(-.119)	[.169; 2.49]	[.882; 4.94]	<-.395>
PHI/DP	-13.1	(0)	(.609)	(2.28)	[-.122; .437]	<-3.48>	
PHI/DC	.126	(0)	(.526)	(3.03)	[-.415; .631]	[.0168; 4.77]	<1.81>
THE/DA	.479	(0)	(.0306)	(-.0594)	(.781)	[.468; 2.12]	<-.00305>
THE/DP	-.849	(0)	(.702)	[.997; .0390]	[.952; 5.63]	<-.0286>	
THE/DC	.287	(0)	(.0281)	(.0524)	(.912)	(5.83)	[.256; 3.18] <.0227>
PSI/DA	.187	(1.08)	[.0537; .301]	[.911; 2.20]	[-.647; 2.68]	<.632>	
PSI/DB	.164	(.120)	(-.122)	(5.50)	[.238; 1.08]	[-.208; 2.87]	<-.126>
PSI/DC	.455	(.618)	(3.63)	(4.96)	[-.544; .480]	[.409; .703]	<.577>
XD/DB	.793	(0)	(.0626)	(.734)	(5.68)	[.213; 2.69]	[.0661; 5.47] <44.8>
YD/DA	.502	(1.47)	(1.76)	[.0544; .303]	[.237; 2.57]	[.0526; 9.02]	<64.0>
ZD/DC	-8.29	(0)	(5.75)	[.981; .0647]	[.690; 2.26]	[.0991; 2.50]	<-6.37>
XD/DC	-.131	(0)	(.0548)	(.921)	(6.02)	[.267; 3.21]	[-.0753; 8.12] <-27.2>
YD/DP	1.59	(.646)	(2.16)	(-3.44)	(7.38)	[-.111; .445]	[.374; 3.16] <-112.>
ZD/DB	1.83	(0)	(.0102)	(.0633)	(5.69)	[.206; 2.70]	[.268; 5.45] <1.47>
PHI/DA ; THE/DB	-.941	(0)	(.0218)	(.743)	[.269; 2.66]	<-.108>	
PHI/DA ; PSI/DP	-3.34	(.0207)	(.946)	(2.24)	[-.0330; .339]	<-.0168>	
THE/DB ; PSI/DP	1.98	(.0208)	(.710)	(5.49)	[-.0134; .569]	<.0519>	
PHI/DB ; PSI/DP	-.481	(.0594)	(2.81)	(5.62)	[-.439; .0917]	<-.00379>	
PHI/DP ; THE/DB	11.3	(0)	(.0208)	(.696)	<.164>		
PHI/DC ; THE/DB	-.147	(0)	(.0207)	(1.28)	[.214; 4.53]	<-.0798>	
THE/DA ; PSI/DP	-1.16	(.0333)	(.692)	(-1.13)	(1.24)	<.0378>	
THE/DP ; PHI/DA	-1.06	(0)	(.0333)	(.705)	(4.83)	<-.119>	
THE/DC ; PHI/DA	.356	(0)	(.0288)	(.894)	[.302; 3.13]	<.0897>	
PSI/DA ; THE/DB	-.146	(.0218)	(.748)	(2.01)	[-.610; 2.66]	<-.0341>	
PSI/DB ; PHI/DA	.171	(.0358)	(-.222)	(.273)	[-.180; 3.32]	<-.00409>	
PSI/DC ; THE/DB	-.385	(.0207)	(1.10)	(5.22)	[-.0653; .744]	<-.0254>	
PSI/DC ; PHI/DA	.549	(.0555)	(.752)	(3.45)	[-.207; .432]	<.0148>	
XD/DB ; PHI/DA	1.00	(0)	(.730)	[.266; 2.68]	[.0754; 5.50]	<159.>	
XD/DB ; PSI/DP	-2.11	(.719)	(5.49)	[-.0216; .567]	[.0600; 5.48]	<-80.3>	
YD/DA ; THE/DB	-.377	(.0218)	(.742)	[.239; 2.63]	[.0561; 9.05]	<-3.45>	
YD/DA ; PSI/DP	-1.64	(.926)	(2.20)	[.00786; .346]	[.00795; 8.07]	<-26.0>	
ZD/DC ; PHI/DA	-10.4	(0)	(.0807)	[.706; 2.24]	[.137; 2.42]	<-24.7>	
ZD/DC ; THE/DB	5.63	(0)	(.0227)	(.0568)	(5.71)	[.198; 2.59]	<.277>
ZD/DC ; PSI/DP	22.2	(.216)	(5.51)	[-.0610; .426]	[.701; 1.68]	<13.5>	
XD/DC ; PHI/DA	-.160	(0)	(.895)	[.297; 3.20]	[-.0969; 8.26]	<-100.>	
XD/DC ; THE/DB	-.131	(0)	(.0680)	(.734)	(4.92)	[.305; 3.34]	<-.359>
XD/DC ; PSI/DP	.377	(.795)	(5.68)	[.0564; .450]	[-.0440; 8.00]	<22.0>	
YD/DP ; PHI/DA	2.06	(.293)	(-1.25)	[-.553; .586]	[.958; 2.57]	<-1.70>	
YD/DP ; THE/DB	-1.18	(.0208)	(.699)	(-3.86)	(7.35)	[.329; 3.28]	<5.26>
ZD/DB ; PHI/DA	2.30	(0)	(.0113)	[.263; 2.70]	[.263; 5.45]	<5.67>	
ZD/DB ; PSI/DP	-4.90	(.0122)	(5.49)	[-.0340; .564]	[.247; 5.44]	<-3.09>	
PHI/DA ; THE/DB ; PSI/DP	2.50	(.0149)	(.0245)	(.726)	<.000661>		
PHI/DC ; THE/DB ; PSI/DP	.351	(.0207)	(-.0329)	(1.83)	<-.000439>		
THE/DC ; PHI/DA ; PSI/DP	-.952	(-.00517)	(.0309)	(.840)	<.000128>		

TABLE II-5 CONTINUED
OH-6A TRANSFER FUNCTION FACTORS

CASE 8 60KT

CONTROL NUMERATORS CONCLUDED:

PSI/DC ; PHI/DA ; THE/DB - .459 (.0209) (.0615) (1.04) <-.000611>
 XD/DB ; PHI/DA ; PSI/DP -2.66 (.0189) (.723) [.0708; 5.50] <-1.10>
 YD/DA ; THE/DB ; PSI/DP 1.24 (.0206) (.722) [.0125; 8.05] <1.19>
 ZD/DC ; PHI/DA ; THE/DB 7.15 (0) (.0230) [.257; 2.56] <1.08>
 ZD/DC ; THE/DB ; PSI/DP -15.0 (.0209) (5.50) [-.0235; .586] <-.591>
 ZD/DC ; PHI/DA ; PSI/DP 27.7 (.0259) (.107) [.726; 1.62] <.203>
 XD/DC ; PHI/DA ; THE/DB - .165 (0) (.889) [.289; 3.43] <-1.72>
 XD/DC ; PHI/DA ; PSI/DP .459 (0) (.841) [-.0665; 8.15] <25.7>
 XD/DC ; THE/DB ; PSI/DP .329 (.271) (5.05) [-.404; .372] <.0623>
 YD/DP ; PHI/DA ; THE/DB -1.54 (.0194) (.604) (-1.83) (2.03) <.0669>
 ZD/DB ; PHI/DA ; PSI/DP -6.11 [.983; .0159] [.245; 5.46] <-.0463>
 ZD/DC ; PHI/DA ; THE/DB ; PSI/DP -19.0 (.0152) (.0289) <-.00833>
 XD/DC ; PHI/DA ; THE/DB ; PSI/DP .414 (-.0246) (.778) <-.00792>

GUST NUMERATORS:

PHI/UG .00285 (0) (0) (0) [.436; 2.51] [.692; 4.78] <.409>
 THE/UG - .0103 (0) (0) (.0639) (.760) (5.68) [.199; 2.50] <-.0177>
 PSI/UG .00785 (0) (0) (5.48) [-.0333; .924] [.555; 1.89] <.131>
 PHI/VG .0501 (0) (0) (2.74) [.109; .317] [.660; 1.13] <.0177>
 THE/VG .0170 (0) (0) (0) (.0199) (.431) (.561) (6.10) <.000497>
 PSI/VG - .0644 (0) (0) (6.37) [.0599; .284] [.943; 1.61] <-.0855>
 PHI/WG .0246 (0) (0) (2.29) [-.0598; .393] [.210; 3.35] <.0974>
 THE/WG .00428 (0) (0) (.0260) (.0427) (6.82) [.371; 3.78] <.000463>
 PSI/WG .0259 (0) (2.86) (4.28) [-.0801; .396] [.0757; .791] <.0312>
 PHI/PG 5.50 (0) [.0632; .284] [.975; 1.69] [.269; 2.62] <8.72>
 THE/PG - .181 (0) (.0199) (.416) (.552) (3.01) [-.644; 2.53] <-.0160>
 PSI/PG 1.12 (2.53) [-.0606; .284] [.931; 1.54] [-.458; 2.25] <2.76>
 PHI/QG 1.30 (0) (.197) (-.278) (-2.09) (3.19) [.237; 2.63] <3.31>
 THE/QG 2.46 (0) (.0242) (.0599) (.709) (5.82) [.226; 2.62] <.101>
 PSI/QG - .533 (.197) (-.257) (7.45) [-.0531; .847] [.300; 2.69] <1.05>
 PHI/RG .0823 (0) [.0386; .311] [.947; 1.55] [.299; 9.66] <1.79>
 THE/RG 11831. (.00144) (.0187) <.319>
 PSI/RG 1.45 (5.53) [.0381; .319] [.00147; .528] [.964; 1.58] <.569>
 XD/UG .0317 (0) (.0641) (.707) (5.67) [.228; 2.36] [-.286; 3.54] <.569>
 ZD/UG .0440 (0) (0) (.0637) (5.67) [.213; 2.38] [.345; 4.45] <1.79>
 YD/VG .0852 (0) (2.80) [.113; .317] [-.609; 1.22] [.482; 4.00] <.569>
 XD/WG - .00377 (0) (0) (.0462) (9.20) [.530; 3.95] [-.0615; 4.97] <-.618>
 ZD/WG .713 (0) (.0637) (2.46) (5.65) [-.0474; .353] [.259; 2.69] <.569>
 PHI/UG ; THE/DB - .0234 (0) (0) (.524) <-.0123>
 PHI/UG ; PSI/DP - .00677 (0) (0) (-.0424) (2.86) (5.25) <.00431>
 THE/UG ; PHI/DA - .0130 (0) (0) (.764) [-.252; 2.50] <-.0622>
 THE/UG ; PSI/DP .0274 (0) (.714) (5.49) [-.00534; .565] <.0343>
 PSI/UG ; PHI/DA .00933 (0) (0) (.118) [.477; 2.01] <.00446>
 PSI/UG ; THE/DB - .00414 (0) (.583) (5.46) [.0619; .545] <-.00391>
 PHI/VG ; THE/DB - .0403 (0) (0) (.0215) (.935) (1.15) <-.000933>
 PHI/VG ; PSI/DP - .141 (0) (.573) (2.31) [-.139; .429] <-.0343>
 THE/VG ; PHI/DA .0193 (0) (0) (.664) [.829; .0861] <.949E-4>
 THE/VG ; PSI/DP - .0449 (0) (0) (.0279) (.700) (6.01) <-.00527>
 PSI/VG ; PHI/DA - .0903 (0) [.0503; .303] [.972; 1.54] <-.0197>
 PSI/VG ; THE/DB .0450 (0) (0) (.0215) (.743) (6.43) <.00462>

TABLE II-5 CONTINUED
OH-6A TRANSFER FUNCTION FACTORS

CASE 8 60KT

GUST NUMERATORS CONTINUED:

PHI/WG ; THE/DB	- .0191 (0) (0) (.0214) [.202; 3.44] <-.00482>
PHI/WG ; PSI/DP	- .0629 (0) (-.0672) (2.28) [-.0462; .390] <-.00147>
THE/WG ; PHI/DA	.00435 (0) (0) (.0285) [.392; 4.16] <.00215>
THE/WG ; PSI/DP	- .0116 (0) (.0478) (.375) (-.506) (6.35) <.000671>
PSI/WG ; PHI/DA	.0280 (0) (.127) (2.61) [-.0327; .376] <.00132>
PSI/WG ; THE/DB	- .0199 (0) (.0214) (4.59) [.00227; .887] <-.00154>
PHI/PG ; THE/DB	-4.05 (0) (.0215) (.742) [.265; 2.70] <-.471>
PHI/PG ; PSI/DP	-14.6 (.0221) (1.05) (2.21) [-.0269; .322] <-.0775>
THE/PG ; PHI/DA	- .457 (0) (.00460) (.748) [.249; 2.46] <-.00951>
THE/PG ; PSI/DP	.475 (.0279) (.700) (2.70) [-.444; 2.61] <.170>
PSI/PG ; PHI/DA	.381 (-.0700) [.540; .155] [.545; 1.95] <-.00242>
PSI/PG ; THE/DB	- .803 (.0215) (.746) (2.28) [-.456; 2.25] <-.149>
PHI/QG ; THE/DB	-1.43 (0) (.0202) (.577) [.298; 2.51] <-.105>
PHI/QG ; PSI/DP	-3.54 (.00985) (.194) (-.393) (-1.51) (2.45) <-.00983>
THE/QG ; PHI/DA	3.04 (0) (.0247) (.722) [.268; 2.62] <.373>
THE/QG ; PSI/DP	-6.58 (.0223) (.704) (5.61) [-.0113; .497] <-.143>
PSI/QG ; PHI/DA	- .915 (.0466) (-.150) (.206) [.118; 2.80] <.0103>
PSI/QG ; THE/DB	1.56 (.0202) (.518) (-1.23) (1.64) <-.0330>
PHI/RG ; THE/DB	-5.68 (0) (.0215) (.773) <-.0945>
PHI/RG ; PSI/DP	-1.12 (-.0986) (2.60) [.267; .118] <.00400>
THE/RG ; PHI/DA	- .367 (0) (.0658) (-.694) [.910; .757] <.00961>
THE/RG ; PSI/DP	.761 (.0305) (.693) (5.52) [-.0257; .568] <.0286>
PSI/RG ; PHI/DA	1.81 (.0273) [.0430; .305] [.976; 1.54] <.0110>
PSI/RG ; THE/DB	-1.03 (.0215) (.758) (5.53) [-.0230; .568] <-.0300>
XD/UG ; PHI/DA	.0400 (0) (.708) [.272; 2.39] [.290; 3.52] <2.00>
XD/UG ; THE/DB	- .0154 (0) (.0628) (.734) (5.66) [.228; 2.73] <-.0300>
XD/UG ; PSI/DP	- .0842 (.713) (5.49) [-.0354; .558] [.286; 3.28] <-1.10>
ZD/UG ; PHI/DA	.0553 (0) (0) [.261; 2.41] [.344; 4.43] <6.30>
ZD/UG ; THE/DB	- .0138 (0) (0) (.0673) (5.67) [.296; 3.04] <-.0489>
ZD/UG ; PSI/DP	- .118 (0) (5.49) [-.0344; .558] [.314; 4.16] <-3.47>
YD/VG ; PHI/DA	.0819 (0) (2.64) [.126; .342] [.666; .658] <.0110>
YD/VG ; THE/DB	- .0649 (0) (.0215) (.869) (1.49) [.419; 4.07] <-.0300>
YD/VG ; PSI/DP	- .125 (.609) (2.13) [-.129; .437] [.232; 5.98] <-1.10>
XD/WG ; PHI/DA	- .00383 (0) (0) [.506; 4.50] [-.182; 5.60] <-2.43>
XD/WG ; THE/DB	- .000597 (0) (0) (.112) (.722) [-.255; 8.98] <-.00388>
XD/WG ; PSI/DP	.0116 (0) (.407) (-.466) (7.88) [.217; 5.15] <-.460>
ZD/WG ; PHI/DA	.896 (0) (2.42) [-.0435; .359] [.301; 2.68] <2.00>
ZD/WG ; THE/DB	- .537 (0) (.0216) (.0623) (5.68) [.229; 2.71] <-.0300>
ZD/WG ; PSI/DP	-1.91 (2.56) (5.42) [-.209; .423] [.155; .483] <-1.10>
XD/UG ; ZD/DC	- .257 (0) (.0580) (5.66) [.217; 2.42] [.287; 3.59] <-6.37>
YD/VG ; ZD/DC	- .696 (0) (.0735) (2.88) [.210; 1.53] [.453; 4.29] <-6.37>
PHI/UG ; THE/DB ; PSI/DP	- .00112 (0) (.105) <-.000118>
THE/UG ; PHI/DA ; PSI/DP	.0345 (0) (.0206) (.734) <.000522>
PSI/UG ; PHI/DA ; THE/DB	- .00521 (0) (.0370) (.660) <-.000127>
PHI/VG ; THE/DB ; PSI/DP	.113 (0) (.0208) (.689) <.00161>
THE/VG ; PHI/DA ; PSI/DP	- .0501 (0) (.0333) (.704) <-.00117>
PSI/VG ; PHI/DA ; THE/DB	.0650 (0) (.0218) (.746) <.00106>
PHI/WG ; THE/DB ; PSI/DP	.0488 (0) (.0210) (-.0695) <-.713E-4>
THE/WG ; PHI/DA ; PSI/DP	- .0119 (0) (.0325) (-.157) <-.604E-4>
PSI/WG ; PHI/DA ; THE/DB	- .0215 (0) (.0217) (.142) <-.664E-4>

TABLE II-5 CONTINUED
OH-6A TRANSFER FUNCTION FACTORS

CASE 8 60KT

GUST NUMERATORS CONCLUDED:

PHI/PG ; THE/DB ; PSI/DP	10.7	(.0162)	(.0242)	(.726)	<.00306>	
THE/PG ; PHI/DA ; PSI/DP	1.21	(-.00312)	(.0237)	(.725)	<-.648E-4>	
PSI/PG ; PHI/DA ; THE/DB	-.223	(.0256)	(-.0267)	(.730)	<.000111>	
PHI/QG ; THE/DB ; PSI/DP	3.81	(.631)	[.988; .0199]	<.000953>		
THE/QG ; PHI/DA ; PSI/DP	-8.07	(.0165)	(.0264)	(.714)	<-.00251>	
PSI/QG ; PHI/DA ; THE/DB	.271	(1.16)	[.909; .0255]	<.000205>		
PHI/RG ; THE/DB ; PSI/DP	-.0914	(.0227)	[-.377; .372]	<-.000286>		
THE/RG ; PHI/DA ; PSI/DP	.954	(.694)	[.988; .0294]	<.000573>		
PSI/RG ; PHI/DA ; THE/DB	-1.30	(.0209)	(.0278)	(.754)	<-.000570>	
XD/UG ; PHI/DA ; THE/DB	-.0195	(0)	(.737)	[.273; 2.74]	<-.108>	
XD/UG ; PHI/DA ; PSI/DP	-.106	(.0208)	(.711)	[.282; 3.28]	<-.0168>	
XD/UG ; THE/DB ; PSI/DP	.0408	(.714)	(5.48)	[-.0160; .570]	<.0519>	
ZD/UG ; PHI/DA ; THE/DB	-.0175	(0)	(0)	[.339; 3.05]	<-.163>	
ZD/UG ; PHI/DA ; PSI/DP	-.147	(0)	(.0208)	[.308; 4.16]	<-.0529>	
ZD/UG ; THE/DB ; PSI/DP	.0371	(0)	(5.48)	[-.0307; .576]	<.0675>	
YD/VG ; PHI/DA ; THE/DB	-.0618	(0)	(.0213)	[.939; .657]	<-.000570>	
YD/VG ; PHI/DA ; PSI/DP	-.0695	(.284)	(3.36)	[-.573; .503]	<-.0168>	
YD/VG ; THE/DB ; PSI/DP	.102	(.0208)	(.693)	[.210; 5.95]	<.0519>	
XD/WG ; PHI/DA ; THE/DB	-.000609	(0)	(0)	[.551; 8.11]	<-.0401>	
XD/WG ; PHI/DA ; PSI/DP	.0119	(0)	(-.143)	[.0761; 5.70]	<-.0556>	
XD/WG ; THE/DB ; PSI/DP	-.0248	(0)	[.142; 1.05]	<-.0272>		
ZD/WG ; PHI/DA ; THE/DB	-.678	(0)	(.0218)	[.280; 2.70]	<-.108>	
ZD/WG ; PHI/DA ; PSI/DP	-2.38	(.0208)	(2.48)	[-.0455; .370]	<-.0168>	
ZD/WG ; THE/DB ; PSI/DP	1.43	(.0208)	(5.47)	[-.0253; .564]	<.0519>	
XD/UG ; ZD/DC ; PHI/DA	-.324	(0)	[.261; 2.45]	[.289; 3.57]	<-24.7>	
XD/UG ; ZD/DC ; THE/DB	.119	(0)	(.0580)	(5.66)	[.215; 2.67]	<.277>
XD/UG ; ZD/DC ; PSI/DP	.682	(5.49)	[-.0343; .557]	[.289; 3.41]	<13.5>	
YD/VG ; ZD/DC ; PHI/DA	-.665	(0)	(.0704)	(1.29)	[.554; 1.40]	<-.118>
YD/VG ; ZD/DC ; THE/DB	.479	(0)	(.0226)	(1.38)	[.415; 4.31]	<.277>
YD/VG ; ZD/DC ; PSI/DP	1.04	(.242)	[.683; 1.21]	[.234; 6.04]	<13.5>	
XD/UG ; PHI/DA ; THE/DB ; PSI/DP	.0514	(.0177)	(.725)	<.000661>		
ZD/UG ; PHI/DA ; THE/DB ; PSI/DP	.0467	(0)	(.0138)	<.000642>		
YD/VG ; PHI/DA ; THE/DB ; PSI/DP	.0575	(.0194)	(.593)	<.000661>		
XD/WG ; PHI/DA ; THE/DB ; PSI/DP	.000522	(0)	(-3.37)	<-.00176>		
ZD/WG ; PHI/DA ; THE/DB ; PSI/DP	1.80	(.0149)	(.0247)	<.000661>		
XD/UG ; ZD/DC ; PHI/DA ; THE/DB	.151	(0)	[.263; 2.67]	<1.08>		
YD/VG ; ZD/DC ; PHI/DA ; THE/DB	.449	(0)	(.0223)	(.514)	<.00515>	
YD/VG ; ZD/DC ; PHI/DA ; PSI/DP	.572	(2.51)	[-.0781; .376]	<.203>		
XD/WG ; ZD/DC ; PHI/DA ; THE/DB	.123	(0)	[.326; 3.73]	<1.72>		
XD/UG ; ZD/DC ; PHI/DA ; THE/DB ; PSI/DP	-.398	(.0209)	<-.00833>			
YD/VG ; ZD/DC ; PHI/DA ; THE/DB ; PSI/DP	-.438	(.0190)	<-.00833>			
XD/WG ; ZD/DC ; PHI/DA ; THE/DB ; PSI/DP	-.302	(-.0262)	<.00792>			

TABLE II-5 CONTINUED
OH-6A TRANSFER FUNCTION FACTORS

CASE 9 80KT

DENOMINATOR: (0) (.0611) (5.70) [.0591;.268][.981;1.79][.241;3.23]<.831>

CONTROL NUMERATORS:

PHI/DA 1.26 (0) (1.43) (2.05) [.0627;.287][.288;3.22]<3.19>
 THE/DB -0.750 (0) (.0286) (.0600) (.789) (5.67) [.233;3.28]<-.0620>
 PSI/DP -3.00 (.703) (2.47) (5.47) [-.463;.378][.508;.583]<-1.39>

PHI/DB .199 (0) (-.0960) (.122) [.183;3.07][.778;5.72]<-.719>
 THE/DA .485 (0) (-.0352) (.0369) (.824) [.520;2.74]<-.00388>

PHI/DA ;THE/DB -0.956 (0) (.0289) (.798) [.284;3.31]<-.241>
 PHI/DA ;PSI/DP -3.79 (.0291) (.925) (2.53) [-.0701;.332]<-.0283>
 THE/DB ;PSI/DP 2.25 (.0275) (.749) (5.46) [-.0302;.592]<.0889>

PHI/DB ;PSI/DP -0.591 (.0712) [-.374;.0895][.900;4.56]<-.00699>
 PHI/DP ;THE/DB 18.7 (0) (.0275) (.724) <.374>
 PHI/DC ;THE/DB -0.184 (0) (.0277) (1.35) [.231;5.16]<-.183>

THE/DA ;PSI/DP -0.136 (.0398) (.753) (-1.18) (1.47) (9.77) <.0698>
 THE/DP ;PHI/DA -1.59 (0) (.0398) (.760) (6.13) <-.294>
 THE/DC ;PHI/DA .512 (0) (.0345) (.890) [.310;3.72]<.218>

PSI/DA ;THE/DB -0.130 (.0289) (.802) (2.39) [-.662;2.82]<-.0571>
 PSI/DB ;PHI/DA .172 (.0478) (-.192) (.304) [-.159;3.92]<-.00733>
 XD/DB ;PHI/DA .910 (0) (.826) [.278;3.34][.0787;5.66]<268.>

YD/DA ;THE/DB -0.396 (.0289) (.797) [.246;3.24][.0646;8.98]<-7.71>
 ZD/DB ;PHI/DA 3.36 (0) (.0369) [.271;3.38][.277;5.41]<41.5>
 XD/DC ;PHI/DA -15.5 (0) (.929) [.295;3.75]<-203.>

YD/DP ;THE/DB -1.34 (.0275) (.728) (-4.52) (7.61) [.328;3.60]<12.0>
 ZD/DC ;PHI/DA -11.3 (0) (.0759) [.628;2.88][.148;2.99]<-63.6>

PHI/DA ;THE/DB ;PSI/DP 2.87 (.0200) (.0329) (.775) <.00146>
 PHI/DC ;THE/DB ;PSI/DP .541 (-.0167) (.0277) (1.77) <-.000442>
 THE/DC ;PHI/DA ;PSI/DP -1.53 (.00222) (.0375) (.824) <-.000105>

PSI/DC ;PHI/DA ;THE/DB -0.444 (.0274) (.0753) (1.09) <-.00100>
 XD/DB ;PHI/DA ;PSI/DP -2.71 (.0258) (.818) [.0727;5.66]<-1.83>
 YD/DA ;THE/DB ;PSI/DP 1.42 (.0272) (.769) [.0149;8.07]<1.93>

ZD/DC ;PHI/DA ;THE/DB 7.18 (0) (.0275) [.272;3.16]<1.97>
 ZD/DC ;PHI/DA ;PSI/DP 33.8 (.0281) (.0823) [.595;2.17]<.370>
 XD/DC ;PHI/DA ;THE/DB -0.321 (0) (.663) [.275;3.78]<-3.03>

XD/DC ;PHI/DA ;PSI/DP 47.1 (.00788) (.856) <.318>
 YD/DP ;PHI/DA ;THE/DB -1.72 (.0256) (.638) (-2.56) (2.75) <.198>
 ZD/DB ;PHI/DA ;PSI/DP -10.1 (.0279) (.0357) [.256;5.44]<-.296>

ZD/DC ;PHI/DA ;THE/DB ;PSI/DP -21.5 (.0265) (.0315) <-.0180>
 XD/DC ;PHI/DA ;THE/DB ;PSI/DP .916 (-.0218) (.481) <-.00963>

TABLE II-5 CONTINUED
OH-6A TRANSFER FUNCTION FACTORS

CASE 10 100KT

DENOMINATOR: (0) (.0551) (1.00) (2.41) (5.65) [-.0146; .297] [-.248; 3.93] <1.03>

CONTROL NUMERATORS:

PHI/DA	1.26	(0)	(.905)	(2.47)	[-.0199; .317]	[.298; 4.01]	<4.58>
THE/DB	-.770	(0)	(.0348)	(.0535)	(.791)	(5.65)	[-.207; 3.89] <-.0972>
PSI/DP	-3.08	(.489)	(2.66)	(5.42)	[-.580; .369]	[.502; .751]	<-1.66>
PHI/DB	.187	(0)	(-.101)	(.140)	[-.292; 3.09]	[.663; 7.00]	<-1.25>
THE/DA	.0453	(0)	(.0379)	(-.0518)	(.813)	(6.27)	[-.778; 3.92] <-.00697>
PHI/DA ; THE/DB	-.983	(0)	(.0351)	(.802)	[-.260; 4.00]	<-.442>	
PHI/DA ; PSI/DP	-3.90	(.0367)	(.943)	(2.67)	[-.116; .320]	<-.0368>	
THE/DB ; PSI/DP	2.36	(.0334)	(.760)	(5.41)	[-.0705; .638]	<.132>	
PHI/DB ; PSI/DP	-.577	(.0894)	[-.529; .0663]	[.810; 5.50]	<-.00688>		
PHI/DP ; THE/DB	28.5	(0)	(.0334)	(.728)	<.693>		
PHI/DC ; THE/DB	-.190	(0)	(.0336)	(1.09)	[-.218; 7.08]	<-.347>	
THE/DA ; PSI/DP	-.148	(.0455)	(.788)	(-1.29)	(2.34)	(6.52)	<-.104>
THE/DP ; PHI/DA	-2.25	(0)	(.0455)	(.793)	(6.77)	<-.549>	
THE/DC ; PHI/DA	.650	(0)	(.0400)	(.814)	[-.297; 4.63]	<.454>	
PSI/DA ; THE/DB	-.151	(.0351)	(.801)	(2.92)	[-.694; 2.60]	<-.0837>	
PSI/DB ; PHI/DA	.215	(.0607)	(-.485)	(-.543)	(1.09)	(-2.36)	<-.00886>
XD/DB ; PHI/DA	.774	(0)	(.965)	[-.232; 3.97]	[.0890; 5.85]	<404.>	
YD/DA ; THE/DB	-.400	(.0351)	(.801)	[-.213; 3.81]	[.0798; 9.30]	<-14.1>	
ZD/DB ; PHI/DA	4.26	(0)	(.0509)	[-.206; 3.88]	[.310; 5.75]	<108.>	
XD/DC ; PHI/DA	2.30	(0)	(.955)	(-8.13)	[-.268; 4.51]	<-363.>	
YD/DP ; THE/DB	-1.42	(.0334)	(.732)	(-5.27)	(8.09)	[-.318; 3.88]	<22.3>
ZD/DC ; PHI/DA	-12.0	(0)	(.0749)	[-.125; 3.46]	[.547; 3.63]	<-141.>	
PHI/DA ; THE/DB ; PSI/DP	3.02	(.0254)	(.0402)	(.807)	<.00249>		
PHI/DC ; THE/DB ; PSI/DP	.593	(-.0111)	(.0336)	(1.88)	<-.000416>		
THE/DC ; PHI/DA ; PSI/DP	-2.04	(.00919)	(.0435)	(.836)	<-.000680>		
PSI/DC ; PHI/DA ; THE/DB	-.665	(.0331)	(.0892)	(.768)	<-.00151>		
XD/DB ; PHI/DA ; PSI/DP	-2.36	(.0322)	(.966)	[-.0675; 5.83]	<-2.49>		
YD/DA ; THE/DB ; PSI/DP	1.51	(.0335)	(.797)	[-.0234; 8.06]	<2.61>		
ZD/DC ; PHI/DA ; THE/DB	7.12	(0)	(.0308)	[-.237; 3.65]	<2.93>		
ZD/DC ; PHI/DA ; PSI/DP	36.9	(.0308)	(.0742)	[-.501; 2.72]	<.621>		
XD/DC ; PHI/DA ; THE/DB	-.534	(0)	(.486)	[-.247; 4.43]	<-5.09>		
XD/DC ; PHI/DA ; PSI/DP	-6.72	(.0150)	(.959)	(-8.36)	<.811>		
YD/DP ; PHI/DA ; THE/DB	-1.80	(.0318)	(.647)	(-3.26)	(3.47)	<.420>	
ZD/DB ; PHI/DA ; PSI/DP	-13.1	(.0335)	(.0504)	[-.259; 5.55]	<-.682>		
ZD/DC ; PHI/DA ; THE/DB ; PSI/DP	-21.7	[-.983; .0368]	<-.0294>				
XD/DC ; PHI/DA ; THE/DB ; PSI/DP	1.58	(-.0148)	(.372)	<-.00871>			

TABLE II-5 CONTINUED
OH-6A TRANSFER FUNCTION FACTORS

CASE 11 120KT

DENOMINATOR: (0) (.0616) (.489) (3.20) (5.47) [-.327;.405][.262;4.62]<1.84>

CONTROL NUMERATORS:

PHI/DA 1.27 (0) (.456) (3.23) [-.373;.428][.308;4.82]<7.99>
 THE/DB -0.795 (0) (.0424) (.0604) (.742) (5.48) [-.229;4.47]<-1.165>
 PSI/DP -3.32 (.360) (3.11) (5.32) [-.737;.376][.300;.948]<-2.51>

PHI/DB .182 (0) (-.0955) (.153) [-.524;3.11][.585;7.70]<-1.53>
 THE/DA .0501 (0) (-.0216) (.0440) (.716) (4.96) [.707;5.65]<-0.00540>

PHI/DA ;THE/DB -1.02 (0) (.0425) (.747) [.279;4.71]<-0.719>
 PHI/DA ;PSI/DP -4.25 (.0439) (.750) (3.11) [-.235;.373]<-0.0605>
 THE/DB ;PSI/DP 2.64 (.0406) (.728) (5.32) [-.149;.684]<.194>

PHI/DB ;PSI/DP -0.621 (.0977) [-.502;.0476][.726;6.44]<-0.00569>
 PHI/DP ;THE/DB 43.5 (0) (.0406) (.694) <1.23>
 PHI/DC ;THE/DB -17.3 (0) (.0410) (.852) <-0.605>

THE/DA ;PSI/DP -0.165 (.0575) (.808) (-1.11) (3.16) (6.11) <.164>
 THE/DP ;PHI/DA -2.50 (0) (.0575) (.806) (9.02) <-1.04>
 THE/DC ;PHI/DA .842 (0) (.0486) (.707) [-.323;5.46]<.862>

PSI/DA ;THE/DB -0.148 (.0425) (.744) (4.00) [-.830;2.46]<-0.113>
 PSI/DB ;PHI/DA .117 (.0721) (4.84) (-8.88) [-.332;.155]<-0.00872>
 XD/DB ;PHI/DA .548 (0) (1.17) [.256;4.58][.0794;6.33]<538.>

YD/DA ;THE/DB -0.431 (.0425) (.746) [.225;4.35][.109;9.43]<-23.0>
 ZD/DB ;PHI/DA 5.24 (0) (.0675) [.217;4.25][.315;5.97]<228.>
 XD/DC ;PHI/DA .474 (0) (.982) (-5.62) (8.04) [.273;5.16]<-560.>

YD/DP ;THE/DB -1.56 (.0406) (.696) (-6.13) (8.49) [.306;4.13]<39.3>
 ZD/DC ;PHI/DA -12.2 (0) (.0881) [.124;4.04][.515;4.19]<-308.>

PHI/DA ;THE/DB ;PSI/DP 3.41 (.0327) (.0484) (.799) <.00431>
 PHI/DC ;THE/DB ;PSI/DP .682 (-.00523) (.0411) (1.85) <-0.00272>
 THE/DC ;PHI/DA ;PSI/DP -2.80 (.0156) (.0534) (.790) <-0.00185>

PSI/DC ;PHI/DA ;THE/DB -0.980 (.0405) (.0966) (.597) <-0.00229>
 XD/DB ;PHI/DA ;PSI/DP -1.81 (.0401) (1.19) [.0655;6.31]<-3.43>
 YD/DA ;THE/DB ;PSI/DP 1.72 (.0411) (.786) [.0463;8.06]<3.60>

ZD/DC ;PHI/DA ;THE/DB 6.31 (0) (.0315) [.230;3.98]<3.15>
 ZD/DC ;PHI/DA ;PSI/DP 40.7 (.0346) (.0885) [.442;3.22]<1.29>
 XD/DC ;PHI/DA ;THE/DB -0.744 (0) (.406) [.249;5.01]<-7.57>

XD/DC ;PHI/DA ;PSI/DP -1.34 (.0235) (1.06) (-5.50) (8.77) <1.63>
 YD/DP ;PHI/DA ;THE/DB -1.94 (.0395) (.649) (-4.13) (4.24) <.873>
 ZD/DB ;PHI/DA ;PSI/DP -17.5 (.0407) (.0673) [.265;5.54]<-1.47>

ZD/DC ;PHI/DA ;THE/DB ;PSI/DP -21.1 [.956;.0471]<-0.0470>
 XD/DC ;PHI/DA ;THE/DB ;PSI/DP 2.27 (-.0159) (.306) <-0.0110>

TABLE II-5 CONTINUED
OH-6A TRANSFER FUNCTION FACTORS

CASE 12 130KT

DENOMINATOR: (0) (.0652) (.383) (3.55) (5.34) [-.595;.453][-.264;5.01]<2.44>

CONTROL NUMERATORS:

PHI/DA	1.28	(0)	(.373)	(3.55)	[-.628;.471][.310;5.28]<10.4>
THE/DB	-.823	(0)	(.0442)	(.0634)	(.708) (5.36) [.238;4.83]<-.204>
PSI/DP	-3.27	(.347)	(3.31)	(5.23)	[-.800;.381][.189;1.03]<-3.00>
PHI/DB	.176	(0)	(-.123)	(.189)	[-.763;2.97][.549;7.77]<-2.19>
THE/DA	.0520	(0)	(-.0389)	(.0432)	(.650) (3.81) [.668;6.80]<-.0100>
PHI/DA ; THE/DB	-1.06	(0)	(.0441)	(.712)	[-.289;5.14]<-.882>
PHI/DA ; PSI/DP	-4.22	(.0479)	(.698)	(3.27)	[-.308;.404]<-.0753>
THE/DB ; PSI/DP	2.69	(.0418)	(.712)	(5.24)	[-.206;.715]<.215>
PHI/DB ; PSI/DP	-.579	(.102)	[-.414;.0449]	[.697;7.24]	<-.00625>
PHI/DP ; THE/DB	51.5	(0)	(.0418)	(.681)	<1.47>
PHI/DC ; THE/DB	-23.3	(0)	(.0425)	(.759)	<-.751>
THE/DA ; PSI/DP	-.173	(.0625)	(.816)	(-1.03)	[-.957;4.49]<.183>
THE/DP ; PHI/DA	-2.77	(0)	(.0624)	(.813)	(8.94) <-1.26>
THE/DC ; PHI/DA	.931	(0)	(.0503)	(.662)	[.335;5.99]<1.11>
PSI/DA ; THE/DB	-.147	(.0441)	(.707)	(4.41)	[-.995;2.52]<-.128>
PSI/DB ; PHI/DA	-9.76	(.0745)	[-.136;.124]	<-.0112>	
XD/DB ; PHI/DA	.419	(0)	(1.43)	[-.279;4.94]	[.0690;6.56]<629.>
YD/DA ; THE/DB	-.457	(.0441)	(.712)	[-.222;4.65]	[.142;9.52]<-28.1>
ZD/DB ; PHI/DA	5.59	(0)	(.0725)	[-.229;4.46]	[.309;6.20]<311.>
XD/DC ; PHI/DA	.663	(0)	(1.07)	(-4.86)	(6.57) [-.267;5.51]<-691.>
YD/DP ; THE/DB	-1.60	(.0418)	(.682)	(-6.57)	(8.69) [-.299;4.25]<47.1>
ZD/DC ; PHI/DA	-12.4	(0)	(.0916)	[-.115;4.35]	[.509;4.47]<-429.>
PHI/DA ; THE/DB ; PSI/DP	3.50	(.0347)	(.0518)	(.796)	<.00502>
PHI/DC ; THE/DB ; PSI/DP	.608	(-.00769)	(.0426)	(2.02)	<-.000403>
THE/DC ; PHI/DA ; PSI/DP	-3.08	(.0169)	(.0570)	(.780)	<-.00232>
PSI/DC ; PHI/DA ; THE/DB	-1.22	(.0421)	(.102)	(.533)	<-.00281>
XD/DB ; PHI/DA ; PSI/DP	-1.39	(.0442)	(1.46)	[-.0655;6.54]	<-3.85>
YD/DA ; THE/DB ; PSI/DP	1.78	(.0424)	(.782)	[-.0629;8.06]	<3.83>
ZD/DC ; PHI/DA ; THE/DB	6.21	(0)	(.0299)	[-.228;4.12]	<3.15>
ZD/DC ; PHI/DA ; PSI/DP	40.8	(.0377)	(.0919)	[-.417;3.47]	<1.71>
XD/DC ; PHI/DA ; THE/DB	-.857	(0)	(.355)	[-.247;5.32]	<-8.59>
XD/DC ; PHI/DA ; PSI/DP	-1.80	(.0277)	(1.23)	(-4.72)	(7.11) <2.06>
YD/DP ; PHI/DA ; THE/DB	-1.96	(.0408)	(.661)	(-4.52)	(4.60) <1.10>
ZD/DB ; PHI/DA ; PSI/DP	-18.4	(.0447)	(.0725)	[-.265;5.66]	<-1.91>
ZD/DC ; PHI/DA ; THE/DB ; PSI/DP	-20.4	[.948;.0518]	<-.0547>		
XD/DC ; PHI/DA ; THE/DB ; PSI/DP	2.51	(-.0291)	(.256)	<-.0188>	

TABLE II-5 CONTINUED
OH-6A TRANSFER FUNCTION FACTORS

CASE 19 HOVER LIGHT WEIGHT

DENOMINATOR: (0) (.257) (.821) (1.92) (5.04) [.0236;.376][-.0256;.470]<.0635>

CONTROL NUMERATORS:

PHI/DA	1.31	(0)	(.0234)	(.263)	(.810)	(1.80)	[.00623;.359]	<.00151>
THE/DB	-.715	(0)	(.0171)	(.285)	(.877)	(5.06)	[-.0249;.516]	<-.00412>
PSI/DP	-2.71	(.413)	(1.91)	(4.92)			[-.197;.444]	[.0690;.487]<-.490>
PHI/DB	.189	(0)	(.0260)	(.364)	(.899)	(5.97)	[-.181;.262]	<.000657>
THE/DA	.629	(0)	(.0359)	(-.296)	(.905)		[.914;.258]	<-.000402>
PHI/DA ;THE/DB	-.945	(0)	(.0166)	(.0235)	(.290)	(.876)		<-.939E-4>
PHI/DA ;PSI/DP	-3.50		(.0235)	(.413)	(1.79)		[-.126;.437]	<-.0116>
THE/DB ;PSI/DP	1.95		(.0126)	(.381)	(4.95)		[-.0206;.517]	<.0124>
PHI/DB ;PSI/DP	-.493		(.0328)	(.416)	(6.15)		[-.0799;.281]	<-.00325>
PHI/DP ;THE/DB	.171	(0)	(.0209)	(.566)			[.0415;.0869]	<.153E-4>
PHI/DC ;THE/DB	-.111	(0)	(.0171)	(-.0892)			[.924;.509]	<.437E-4>
THE/DA ;PSI/DP	-1.67		(.0547)	(.120)	(-.351)	(.599)		<.00231>
THE/DP ;PHI/DA	-.181	(0)	(.314)	(2.85)			[.000;.0226]	<-.826E-4>
THE/DC ;PHI/DA	-.0554	(0)	(.00867)	(.0282)	(.233)	(-2.09)		<.659E-5>
PSI/DA ;THE/DB	-.155		(.966)	[.394;.0725]			[-.886;1.27]	<-.00128>
PSI/DB ;PHI/DA	.0836		(.0234)	(.485)	(-1.84)		[.614;2.15]	<-.00809>
XD/DB ;PHI/DA	1.13	(0)	(.0234)	(.291)	(.877)		[.0657;5.18]	<.181>
YD/DA ;THE/DB	-.366	(0)	(.0167)	(.290)	(.874)		[.108;9.08]	<-.128>
ZD/DB ;PHI/DA	-.00457	(0)	(.0232)	(1.27)	(4.72)		[-.825;9.93]	<-.0629>
XD/DC ;PHI/DA	1.41	(0)	(.0178)	(.233)	(-2.64)			<-.0155>
YD/DP ;THE/DB	-1.27	(0)	(-.00353)	(.413)	(5.90)		[-.991;.407]	<.00181>
ZD/DC ;PHI/DA	-11.0	(0)	(.0314)	(.463)	(1.81)		[.108;.336]	<-.0325>
PHI/DA ;THE/DB ;PSI/DP	2.54		(.0119)	(.0237)	(.387)			<.000277>
PHI/DC ;THE/DB ;PSI/DP	.147		(.0126)	(-.0953)	(.751)			<-.000134>
THE/DC ;PHI/DA ;PSI/DP	.308		(-.00497)	(.0316)	(-.192)			<.928E-5>
PSI/DC ;PHI/DA ;THE/DB	-.830		(.0855)	[.711;.0214]				<-.326E-4>
XD/DB ;PHI/DA ;PSI/DP	-3.02		(.0234)	(.386)	[.0647;5.20]			<-.736>
YD/DA ;THE/DB ;PSI/DP	1.27		(.0122)	(.383)	[.0588;8.01]			<.383>
ZD/DC ;PHI/DA ;THE/DB	7.93	(0)	(.0151)	(.0303)	(.633)			<.00229>
ZD/DC ;PHI/DA ;PSI/DP	29.5		(.0286)	(1.80)	[-.106;.443]			<.297>
XD/DC ;PHI/DA ;THE/DB	.0427	(0)	(-.0232)	(.245)	(-.710)			<.000172>
XD/DC ;PHI/DA ;PSI/DP	-9.75		(.0149)	(-.210)				<.0305>
YD/DP ;PHI/DA ;THE/DB	-1.77	(0)	(.0179)	(.0490)	(.279)			<-.000432>
ZD/DB ;PHI/DA ;PSI/DP	.0231		(.0222)	(9.79)	[-.160;5.03]			<.127>
ZD/DC ;PHI/DA ;THE/DB ;PSI/DP	-21.4		(.0113)	(.0289)				<-.00700>
XD/DC ;PHI/DA ;THE/DB ;PSI/DP	-.291		[.0960;.0674]					<-.00132>

TABLE II-5 CONTINUED
OH-6A TRANSFER FUNCTION FACTORS

CASE 25 60KT MAX CLIMB

DENOMINATOR: 0) (.0750) (5.34) [-.0769;.341] [.997;1.46] [.231;2.70] <.728>

CONTROL NUMERATORS:

PHI/DA	1.29	(0)	(1.27)	(1.61)	[-.0974;.361]	[.301;2.76]	<2.63>
THE/DB	-.745	(0)	(.0194)	(.0746)	(.707)	(5.34)	[-.212;2.68] <-.0292>
PSI/DP	-2.63	(5.19)	[-.298;.429]	[.0588;.523]	[.998;1.45]	<-1.44>	
PHI/DB	.184	(0)	(-.183)	(.213)	(2.46)	(5.19)	[.403;2.65] <-.647>
THE/DA	.587	(0)	(.744)	[.952;.0544]	[.428;2.38]	<.00729>	
PHI/DA ; THE/DB	-.974	(0)	(.0187)	(.712)	[-.290;2.76]	<-.0990>	
PHI/DA ; PSI/DP	-3.38	(.0230)	(1.38)	(1.56)	[-.122;.380]	<-.0241>	
THE/DB ; PSI/DP	1.96	(.0173)	(.704)	(5.20)	[-.200;.615]	<.0469>	
PHI/DB ; PSI/DP	-.474	(.0503)	(2.25)	(6.16)	[-.189;.216]	<-.0154>	
PHI/DP ; THE/DB	12.1	(0)	(.0173)	(.697)	<.146>		
PHI/DC ; THE/DB	-.169	(0)	(.0182)	(.825)	[.224;5.55]	<-.0778>	
THE/DA ; PSI/DP	-1.41	(.0396)	(.621)	(-.676)	(1.24)	<.0291>	
THE/DP ; PHI/DA	-.825	(0)	(.0396)	(.657)	(4.22)	<-.0906>	
THE/DC ; PHI/DA	.365	(0)	(.0217)	(.852)	[.408;3.18]	<.0683>	
PSI/DA ; THE/DB	-.150	(.0187)	(.710)	(3.23)	[-.936;2.23]	<-.0318>	
PSI/DB ; PHI/DA	.106	(.0385)	(1.94)	(-2.23)	[-.102;.847]	<-.0126>	
XD/DB ; PHI/DA	1.06	(0)	(.766)	[.287;2.76]	[.104;5.27]	<172.>	
YD/DA ; THE/DB	-.398	(.0187)	(.711)	[.259;2.67]	[.0936;9.16]	<-3.17>	
ZD/DB ; PHI/DA	2.32	(0)	(.0123)	[.278;2.75]	[.223;5.48]	<6.50>	
XD/DC ; PHI/DA	-10.6	(0)	(.900)	[.394;3.26]	<-102.>		
YD/DP ; THE/DB	-1.16	(.0173)	(.699)	(-4.19)	(7.11)	[.309;3.35] <4.67>	
ZD/DC ; PHI/DA	-10.8	(0)	(.106)	[-.669;2.00]	[-.162;2.56]	<-30.1>	
PHI/DA ; THE/DB ; PSI/DP	2.55	(.00992)	(.0261)	(.721)	<.000476>		
PHI/DC ; THE/DB ; PSI/DP	.370	(.0188)	(-.0456)	(1.64)	<-.000523>		
THE/DC ; PHI/DA ; PSI/DP	-.891	(-.00884)	(.0306)	(.957)	<.000230>		
PSI/DC ; PHI/DA ; THE/DB	-.855	(.0177)	(.0647)	(.621)	<-.000610>		
XD/DB ; PHI/DA ; PSI/DP	-2.75	(.0205)	(.771)	[.100;5.29]	<-1.22>		
YD/DA ; THE/DB ; PSI/DP	1.28	(.0155)	(.715)	[.0474;8.05]	<.921>		
ZD/DC ; PHI/DA ; THE/DB	7.44	(0)	(.0189)	[.254;2.62]	<.964>		
ZD/DC ; PHI/DA ; PSI/DP	28.2	(.0276)	(.158)	[.641;1.56]	<.296>		
XD/DC ; PHI/DA ; THE/DB	-.235	(0)	(.241)	[.339;3.36]	<-.640>		
XD/DC ; PHI/DA ; PSI/DP	.343	(.00795)	(.991)	[.0780;8.97]	<.217>		
YD/DP ; PHI/DA ; THE/DB	-1.56	(.0126)	(.611)	(-1.92)	(2.05)	<.0474>	
ZD/DB ; PHI/DA ; PSI/DP	-6.06	[.923;.0196]	[.208;5.47]	<-.0696>			
ZD/DC ; PHI/DA ; THE/DB ; PSI/DP	-19.6	(.0113)	(.0292)	<-.00649>			
XD/DC ; PHI/DA ; THE/DB ; PSI/DP	.468	(.106)	(-.319)	<-.0159>			

TABLE II-5 CONCLUDED
OH-6A TRANSFER FUNCTION FACTORS

CASE 26 60 KT AUTOROTATION

DENOMINATOR: (0) (.0545) (6.16) [.127;.187][.872;2.21][.193;2.39]<.331>

CONTROL NUMERATORS:

PHI/DA 1.23 (0) [.162;.195][.903;2.11][.203;2.36]<1.17>
 THE/DB -.737 (0) (.0192) (.0544) (.775) (6.10) [.256;2.54]<-.0236>
 PSI/DP -2.60 (1.52) (1.88) (5.95) [.577;.330][-.267;.333]<-.534>

PHI/DB .215 (0) (.0579) (-.0630) [.0347;2.52][.817;4.88]<-.118>
 THE/DA .550 (0) (.0246) (-.0978) (.773) [.257;2.06]<-.00436>

PHI/DA ;THE/DB -.919 (0) (.0194) (.775) [.272;2.48]<-.0848>
 PHI/DA ;PSI/DP -3.20 (.0160) (1.31) (2.02) [.0994;.215]<-.00626>
 THE/DB ;PSI/DP 1.91 (.0191) (.735) (5.93) [.187;.476]<.0360>

PHI/DB ;PSI/DP -.543 (.0390) (.114) (-.210) (3.20) (3.89)<.00633>
 PHI/DP ;THE/DB 8.00 (0) (.0191) (.717)<.109>
 PHI/DC ;THE/DB -.171 (0) (.0189) (2.35) [.0960;2.78]<-.0587>

THE/DA ;PSI/DP -1.33 (.0249) (.669) (.801) (-1.61)<.0285>
 THE/DP ;PHI/DA -1.00 (0) (.0249) (.716) (4.88)<-.0871>
 THE/DC ;PHI/DA .407 (0) (.0237) (1.20) [.218;2.60]<.0780>

PSI/DA ;THE/DB -.148 (.0194) (.773) (1.15) [-.127;3.30]<-.0277>
 PSI/DB ;PHI/DA .251 (.0428) [.237;.137][-.0622;4.50]<.00409>
 XD/DB ;PHI/DA .941 (0) (.734) [.275;2.52][-.0133;5.61]<138.>

YD/DA ;THE/DB -.356 (.0194) (.775) [.254;2.51][-.0178;8.99]<-2.71>
 ZD/DB ;PHI/DA 2.16 (0) (.00307) [.285;2.57][.277;5.44]<1.30>
 XD/DC ;PHI/DA -.177 (0) (1.19) [.215;2.61][-.198;8.52]<-104.>

YD/DP ;THE/DB -1.15 (.0191) (.720) (-3.28) (7.47) [.365;3.02]<3.51>
 ZD/DC ;PHI/DA -10.0 (0) (.0411) [.142;2.34][-.709;2.43]<-13.2>

PHI/DA ;THE/DB ;PSI/DP 2.38 (.739) [.977;.0208]<.000759>
 PHI/DC ;THE/DB ;PSI/DP .439 (-.0158) (.0195) (1.52)<-.000205>
 THE/DC ;PHI/DA ;PSI/DP -1.05 (.00496) (.0243) (.920)<-.000117>

PSI/DC ;PHI/DA ;THE/DB -.0491 (.0208) (.0601) (9.22)<-.000567>
 XD/DB ;PHI/DA ;PSI/DP -2.43 (.0204) (.724) [.0102;5.61]<-1.13>
 YD/DA ;THE/DB ;PSI/DP 1.15 (.0203) (.738) [-.0297;8.06]<1.12>

ZD/DC ;PHI/DA ;THE/DB 6.75 (0) (.0215) [.280;2.46]<.875>
 ZD/DC ;PHI/DA ;PSI/DP 25.9 [.958;.0275][.693;1.91]<.0713>
 XD/DC ;PHI/DA ;THE/DB -.178 (0) (1.39) [.195;2.64]<-1.72>

XD/DC ;PHI/DA ;PSI/DP .458 (.00569) (.917) [-.198;8.53]<.174>
 YD/DP ;PHI/DA ;THE/DB -1.45 (.0213) (.667) (-1.80) (2.00)<.0742>
 ZD/DB ;PHI/DA ;PSI/DP -5.61 (.00188) (.0210) [.264;5.48]<-.00666>

ZD/DC ;PHI/DA ;THE/DB ;PSI/DP -17.4 (.0190) (.0256)<-.00852>
 XD/DC ;PHI/DA ;THE/DB ;PSI/DP .461 (0) (.993)<.458>

SECTION III

BOEING VERTOL BO-105C

The BO-105C is a twin turbine light weight utility helicopter designed by Messerschmitt-Bölkow-Blohm and marketed in the US by Boeing-Vertol. It has a maximum gross weight of 2300 kg (5070 lb) and seats a pilot and five passengers. The BO-105C is powered by two Allison 250-C18 or -C20 turbo-shaft engines. The main rotor system is a four-bladed, soft-in-plane, hingeless design.

The control system is hydraulically actuated. Cyclic controls involve a breakout and linear force gradient, the pedals have zero breakout and force gradient, and the collective stick has zero breakout and an adjustable force gradient.

The derivative data presented here are transcribed directly from Ref. 4. They were generated by the Boeing-Vertol Y-92 trim and stability analysis computer program. The flexible blade attachment to the hub was modeled as an equivalent flapping hinge. Model parameters were matched on the basis of the natural frequencies of a flexibly attached blade.

The stability derivative data, as taken directly from Ref. 4, do not contain the effects of a cross product of inertia, and thereby differ from the other vehicles included in this report. A non-zero I_{xz} is indicated in Ref. 9 and could be used to modify the lateral-directional derivative data presented here. The potential impact of such a modification is discussed in Volume Two (Ref. 1).

Several vehicle reference frames appear in the background documents (Refs. 4 and 9) with each differing in its datum location. The convention adopted here is based on a fuselage nose datum — that used in Ref. 9. Other reference frames include the MBB rotor reference axis which is taken with respect to the intersection of main rotor and tail rotor shafts (FS 100.4) and the Boeing-Vertol frame referenced to the main hub (FS 98.1).

Preceding page blank

PRECEDING PAGE BLANK

TABLE III-1

BO-105C DESCRIPTIVE DATA

MAIN ROTOR

Blades 4
 Radius 4.91 m (16.11 ft)
 Chord 0.27 m (0.886 ft)
 Section NACA 23012 mod
 Hub type Hingeless
 Twist -8 deg linear
 Shaft tilt 3 deg forward
 Design rpm 403 to 433 (power on), 361 to 467 (power off)*
 Hub location FS 98.44, WL 61.2[†]
 Blade flapping inertia 219.50 kg-m² (161.9 slug-ft²)[†]

TAIL ROTOR

Blades 2
 Radius 0.95 m (3.12 ft)
 Chord 0.18 m (0.59 ft)
 Twist Zero
 Gear ratio 5.24
 Hub location FS 335, WL 68.7, BL -12.5[†]

HORIZONTAL STABILIZER

Area 0.809 m² (8.71 ft²)[†]
 Aspect ratio 8.09[†]
 Quarter chord location FS 277.5, WL 25.84[†]
 Dihedral Zero[†]
 Incidence Zero[†]

* 424 rpm for tabulated data

† From Ref. 9.

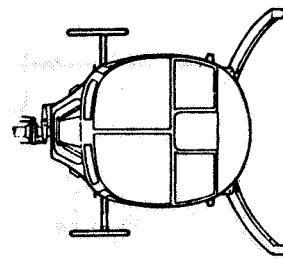
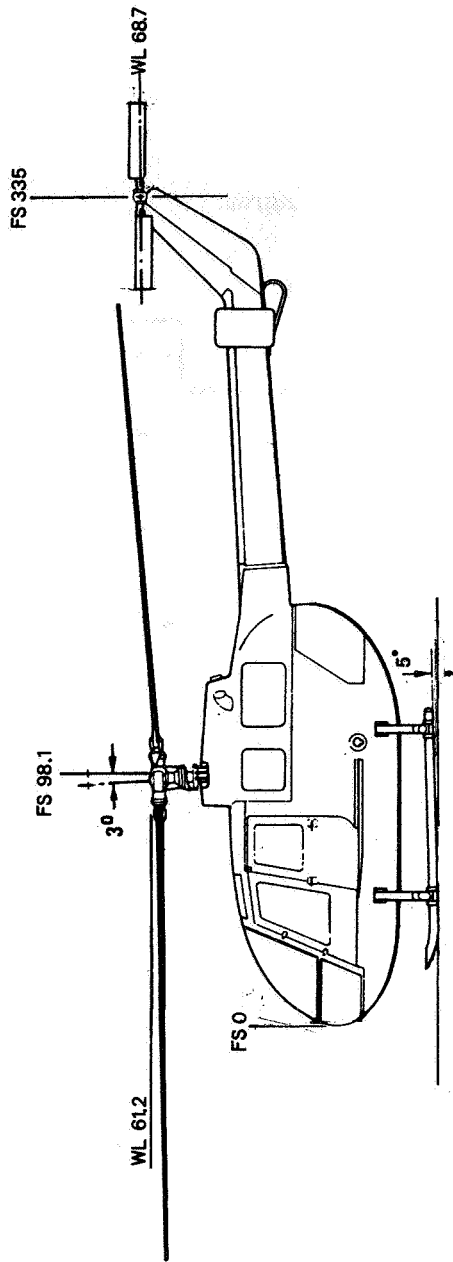
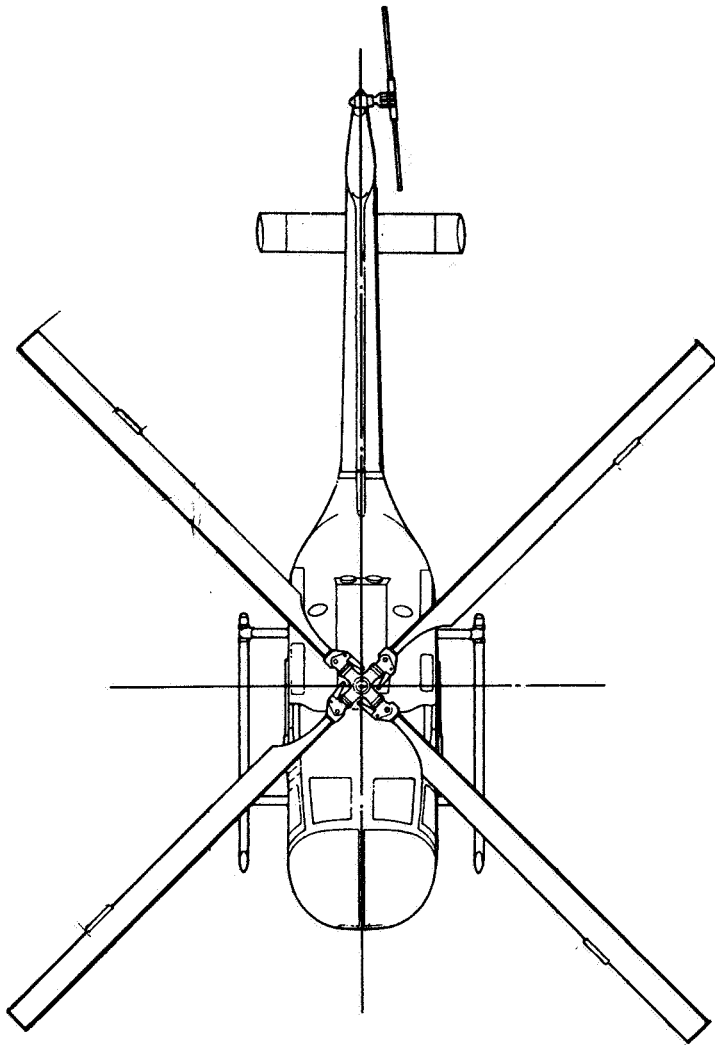
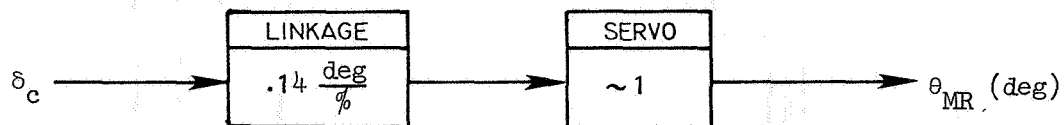

Figure III-1. BO-105C General Arrangement

a. Block Diagram

COLLECTIVE



- All cockpit control deflections shown in this diagram have units of % full travel.

PITCH

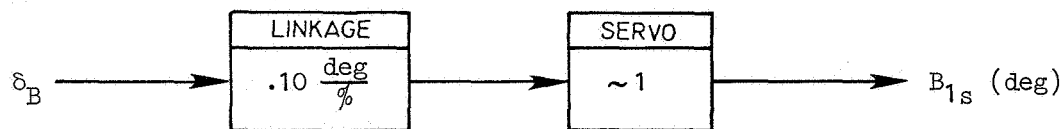

ROLL

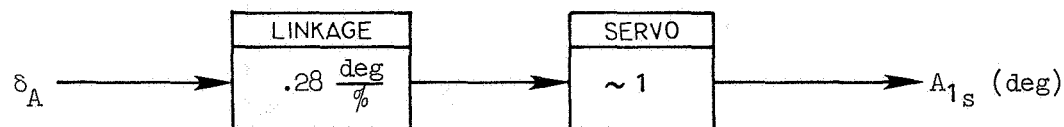

YAW

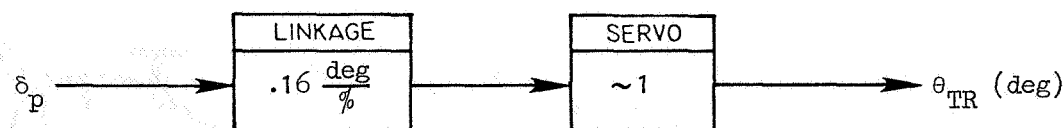

Figure III-2. B0-105C Control System Description

b. Cockpit Controller Characteristics

CONTROLLER	100% FULL TRAVEL cm (in)	FORCE GRADIENT N/cm (lb/in)	BREAKOUT N (lb)
Collective, δ_c	22.86 (9)	Adjustable	—
Longitudinal Cyclic, δ_B	30.78 (12.12)	1.75 (1)	2.63 (1.5)
Lateral Cyclic, δ_A	21.97 (8.65)	1.75 (1)	1.31 (.75)
Rotary Rudder Pedal, δ_P	11.02 (4.34)	zero	zero

Figure III-2 (Concluded)

a. Loading Envelope

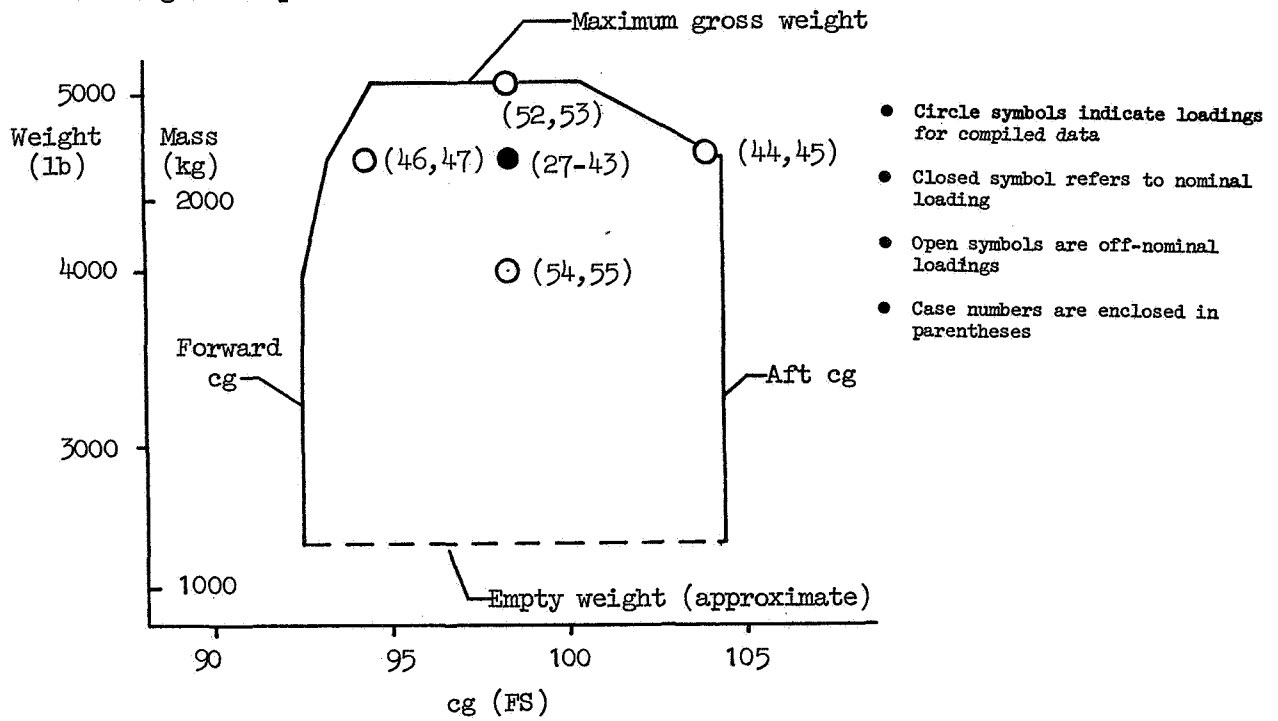

- The fuselage nose is the FS datum used here. Other datums in use are the MBB rotor reference axis (RRA) at FS 100.4 and the Boeing Vertol rotor hub reference at FS 98.1.

b. Moments of Inertia for Compiled Data

CONDITION	MASS (WEIGHT) kg (lb)	cg FS	I_x	I_y kg-m ² (slug-ft ²)	I_z	I_{xz}
Nominal Weight	2096 (4620)	94.4 to 103.9	1803(1330)	4892(3608)	4428(3266)	Zero
Heavy Weight	2300 (5070)	98.4	1924(1419)	5063(3734)	4515(3330)	Zero
Light Weight	1814 (4000)	98.4	1638(1208)	4655(3433)	4298(2170)	Zero

Figure III-3. BO-105C Loading Summary

TABLE III-2

BO-105C INDEX OF FLIGHT CONDITIONS
FOR DERIVATIVES AND TRANSFER FUNCTION FACTORS

CASE	CONDITION	AIRSPEED kt	VERTICAL VELOCITY m/sec (ft/sec)	ALTITUDE m (ft)	MASS (WEIGHT) kg (lb)	cg FS	REPORT PAGE NUMBER	
							DERIVATIVES SI (US)	TRANSFER FUNCTIONS
27	Airspeed Variation ↓	-20	Zero	Sea Level	2096(4620)	98.4	74 (84)	94
28		-10						
29		Hover						
30		10						
31		20						
32		40						
33		60						
34		80						
35		100						
36		120						
37	145	5.1 (16.7) ↓	Zero	Sea Level	2096(4620)	98.4	77 (87)	110
38	Climb							
39	Descent							
40	Climb							
41	Descent							
42	Climb							
43	Descent							
44	Aft cg							
45	Aft cg							
46	Forward cg							
47	Forward cg	103.9 ↓	Zero	Sea Level	2096(4620)	98.4	80 (90)	111
48	Operation at altitude							
49	100							
50	Hover							
51	100							
52	Heavy Weight							
53	100							
54	Light Weight							
55	100							
48	Operation at altitude ↓							
49		100	3048 (10000)					
51	Heavy Weight ↓	Hover	Zero	Sea Level	2300 (5070)	98.4	82 (92)	
52		100						
54	Light Weight ↓	Hover	Zero	Sea Level	1814 (4000)	98.4	83 (93)	
55		100						

* Extended list of transfer function factors.

TABLE III-3
 B0-105C STABILITY AND CONTROL DERIVATIVES -- SI UNITS
 (BODY-FIXED FRL AXIS SYSTEM)

CASE	27	-20 KT		LEVEL FLIGHT AT SEA LEVEL			2096 KG	MID CG		
	PHI	THETA	PSI	ALPHA	BETA	GAMMA	ΘMR	B1S	A1S	ΘTR
	-2.45	2.31	-0.09	-177.69	0.00	180.00	13.56	-1.36	-0.34	8.00
	IDOT		ZDOT	U0	V0	W0	VTO			
	-10.29		0.00	-10.28	0.00	-0.41	10.29			
	U	W	Q	V	P	R	DC	DB	DA	DP
X	-0.0270	0.0217	0.5671	0.0024	-0.1790	-0.0136	0.0585	0.0986	-0.0044	-0.0143
Z	0.2359	-0.4538	-0.1077	-0.0082	-0.0321	0.4318	-1.1180	-0.0563	-0.0119	-0.0047
N	0.0781	-0.0369	-3.4330	-0.0181	-0.9080	0.0206	-0.1067	-0.3868	0.0636	0.0131
Y	-0.0123	-0.0027	-0.2135	0.0047	-0.6048	0.1764	-0.0081	0.0031	0.0930	-0.1796
L'	-0.0725	-0.0025	2.2700	-0.2018	-9.3138	0.0622	-0.0134	0.1812	1.0107	-0.3643
N'	0.0338	-0.0005	0.1027	0.0361	-0.1038	-0.6328	0.1964	0.0060	0.0241	0.5006

CASE	28	-10 KT		LEVEL FLIGHT AT SEA LEVEL			2096 KG	MID CG		
	PHI	THETA	PSI	ALPHA	BETA	GAMMA	ΘMR	B1S	A1S	ΘTR
	-2.80	2.37	-0.11	-177.63	0.01	180.00	14.16	-0.96	-0.34	9.54
	IDOT		ZDOT	U0	V0	W0	VTO			
	-5.14		0.00	-5.14	0.00	-0.21	5.14			
	U	W	Q	V	P	R	DC	DB	DA	DP
X	-0.0228	0.0160	0.5297	0.0020	-0.2067	-0.0302	0.0536	0.0991	-0.0029	-0.0146
Z	0.1508	-0.3610	-0.0273	-0.0067	0.0184	0.4539	-1.1528	-0.0265	-0.0052	-0.0018
N	0.0834	-0.0151	-3.4094	-0.0144	-0.8250	0.0469	-0.0685	-0.3862	0.0669	0.0171
Y	-0.0085	-0.0002	-0.1768	0.0677	-0.6290	0.0710	-0.0078	0.0003	0.0948	-0.1910
L'	-0.0733	0.0005	2.2850	-0.1967	-9.4074	-0.1780	-0.0382	0.1765	1.0366	-0.3873
N'	0.0268	-0.0033	-0.0363	0.0232	0.1066	-0.3465	0.2165	0.0091	0.0263	0.5327

CASE	29	0 KT		LEVEL FLIGHT AT SEA LEVEL			2096 KG	MID CG		
	PHI	THETA	PSI	ALPHA	BETA	GAMMA	ΘMR	B1S	A1S	ΘTR
	-2.97	2.64	0.00	2.63	-0.14	0.00	14.32	-0.42	-0.33	10.17
	IDOT		ZDOT	U0	V0	W0	VTO			
	0.00		0.00	0.00	0.00	0.00	0.00			
	U	W	Q	V	P	R	DC	DB	DA	DP
X	-0.0166	0.0124	0.4909	0.0004	-0.2213	-0.0363	0.0536	0.0947	-0.0005	-0.0144
Z	0.0100	-0.3317	0.1006	-0.0010	0.0449	0.5581	-1.1857	0.0051	-0.0019	-0.0016
N	0.0663	-0.0087	-3.3972	-0.0130	-0.8400	0.0439	-0.0317	-0.3830	0.0629	0.0227
Y	-0.0012	-0.0054	-0.1473	-0.0320	-0.5320	0.0625	-0.0059	0.0046	0.0962	-0.1966
L'	-0.0365	-0.0396	2.3006	-0.2075	-9.2439	-0.2240	-0.0502	0.1807	1.0412	-0.3987
N'	-0.0025	0.0061	-0.1215	0.0325	-0.0759	-0.3270	0.2225	-0.0018	0.0134	0.5485

TABLE III-3 CONTINUED
 BO-105C STABILITY AND CONTROL DERIVATIVES -- SI UNITS
 (BODY-FIXED FRL AXIS SYSTEM)

CASE 30 10 KT LEVEL FLIGHT AT SEA LEVEL 2096 KG MID CG

	PHI	THETA	PSI	ALPHA	BETA	GAMMA	ΘMR	B1S	A1S	ΘTR
	-2.76	2.27	-0.11	2.28	-0.00	0.00	14.12	-0.10	-0.28	9.70
	XDOT		ZDOT	U0	V0	W0	VT0			
	5.14		0.00	5.14	-0.00	0.20	5.14			
	U	W	Q	V	P	R	DC	DB	DA	DP
X	-0.0196	0.0148	0.5201	-0.0000	-0.2097	-0.0245	0.0388	0.0957	-0.0031	-0.0144
Z	-0.1320	-0.3768	0.0464	0.0025	-0.3505	0.4668	-1.1544	0.0364	0.0039	0.0024
H	0.0593	-0.0012	-3.4105	-0.0158	-0.8600	0.0494	0.0004	-0.3844	0.0674	0.0248
Y	0.0037	-0.0045	-0.1595	-0.1259	-0.6369	0.1249	-0.0116	0.0011	0.0986	-0.1919
L*	-0.0202	-0.0111	2.3180	-0.2290	-9.4386	0.0537	-0.0698	0.1739	1.0450	-0.3902
M*	-0.0233	0.0079	-0.0601	0.0474	0.1119	-0.4741	0.2203	0.0080	0.0153	0.5353

CASE 31 20 KT LEVEL FLIGHT AT SEA LEVEL 2096 KG MID CG

	PHI	THETA	PSI	ALPHA	BETA	GAMMA	ΘMR	B1S	A1S	ΘTR
	-2.41	2.07	-0.09	2.07	-0.00	0.00	13.56	0.33	-0.21	8.34
	XDOT		ZDOT	U0	V0	W0	VT0			
	10.29		0.00	10.28	-0.00	0.37	10.29			
	U	W	Q	V	P	R	DC	DB	DA	DP
X	-0.0154	0.0193	-0.5601	-0.0004	-0.1695	-0.0301	0.0289	0.0938	-0.0052	-0.0131
Z	-0.1978	-0.4699	0.0196	0.0021	-0.1383	0.4159	-1.1252	0.0626	0.0111	0.0001
H	0.0671	0.0056	-3.4423	-0.0113	-0.8750	0.0500	0.0324	-0.3824	0.0645	0.0267
Y	0.0093	-0.0026	-0.1733	-0.0725	-0.5497	0.0276	-0.0084	0.0080	0.0962	-0.1808
L*	-0.0171	-0.0090	2.3300	-0.2236	-9.1973	-0.2979	-0.0659	0.1908	1.0183	-0.3684
M*	-0.0391	-0.0047	0.1101	0.0544	-0.2249	-0.2290	0.1861	-0.0022	0.0108	0.5046

CASE 32 40 KT LEVEL FLIGHT AT SEA LEVEL 2096 KG MID CG

	PHI	THETA	PSI	ALPHA	BETA	GAMMA	ΘMR	B1S	A1S	ΘTR
	-1.97	1.63	-0.06	1.63	-0.00	0.00	12.49	1.08	-0.10	5.75
	XDOT		ZDOT	U0	V0	W0	VT0			
	20.58		0.00	20.57	-0.00	0.58	20.58			
	U	W	Q	V	P	R	DC	DB	DA	DP
X	-0.0245	0.0253	0.6431	0.0013	-0.1330	-0.0260	0.0198	0.0884	-0.0091	-0.0122
Z	-0.1277	-0.6648	-0.0234	0.0023	-0.1362	0.3343	-1.2198	0.1334	0.0181	0.0032
H	0.0731	0.0327	-3.4724	-0.0077	-0.9120	0.0647	0.1010	-0.3826	0.0701	0.0236
Y	0.0044	-0.0001	-0.0563	-0.0779	-0.7429	0.0728	-0.0119	0.0118	0.0919	-0.1891
L*	-0.0358	-0.0175	2.3650	-0.2212	-9.4976	-0.2071	-0.0434	0.1900	1.0299	-0.3859
M*	-0.0190	-0.0264	-0.0142	0.0765	0.0934	-0.3490	0.1159	0.0035	0.0161	0.5278

TABLE III-3 CONTINUED
 BO-105C STABILITY AND CONTROL DERIVATIVES -- SI UNITS
 (BODY-FIXED FRL AXIS SYSTEM)

CASE	33	60 KT	LEVEL FLIGHT AT SEA LEVEL				2096 KG	MID CG			
	PHI	THETA	PSI	ALPHA	BETA	GAMMA	ΘHR	B1S	A1S	ΘTR	
	-2.08	0.59	-0.02	0.59	-0.00	0.00	12.28	1.97	-0.06	4.77	
	XDOT		ZDOT	U0	V0	W0	VT0				
	30.87		0.00	30.86	-0.00	0.32	30.87				
	U	W	Q	V	P	R	DC	DB	DA	DP	
X	-0.0338	0.0311	0.6384	0.0014	-0.1137	-0.0195	0.0190	0.0844	-0.0105	-0.0124	
Z	-0.0564	-0.7886	0.0565	0.0039	-0.2896	0.4867	-1.3723	0.2157	0.0333	0.0061	
M	0.0586	0.0423	-3.6151	-0.0061	-0.9460	0.0252	0.2033	-0.3922	0.0683	0.0254	
Y	0.0059	-0.0051	-0.1146	-0.0910	-0.7155	0.1808	-0.0179	0.0116	0.0926	-0.2082	
L'	-0.0327	-0.0338	2.3950	-0.2259	-9.3541	-0.0251	-0.1205	0.1915	1.0296	-0.4258	
M'	-0.0181	-0.0304	0.2080	0.0825	-0.0220	-0.6627	0.1203	0.0148	0.0116	0.5810	

CASE	34	80 KT	LEVEL FLIGHT AT SEA LEVEL				2096 KG	MID CG			
	PHI	THETA	PSI	ALPHA	BETA	GAMMA	ΘHR	B1S	A1S	ΘTR	
	-2.49	-0.86	0.03	-0.86	0.00	0.00	12.64	2.69	-0.01	4.54	
	XDOT		ZDOT	U0	V0	W0	VT0				
	41.16		0.00	41.15	0.00	-0.62	41.16				
	U	W	Q	V	P	R	DC	DB	DA	DP	
X	-0.0423	0.0292	0.6129	0.0012	-0.1215	-0.0244	0.0062	0.0835	-0.0096	-0.0124	
Z	-0.0158	-0.8734	0.0051	0.0091	-0.5216	0.4669	-1.5257	0.3076	0.0498	0.0062	
M	0.0503	0.0559	-3.6267	-0.0060	-0.9620	0.0246	0.3010	-0.4088	0.0639	0.0273	
Y	0.0060	-0.0078	-0.1784	-0.1083	-0.6730	0.1320	-0.0227	0.0114	0.0929	-0.2258	
L'	-0.0334	-0.0471	2.4250	-0.2409	-9.1807	-0.1203	-0.1571	0.1901	1.0308	-0.4621	
M'	-0.0108	-0.0235	0.4221	0.0911	-0.0607	-0.5253	0.1162	0.0205	0.0117	0.6303	

CASE	35	100 KT	LEVEL FLIGHT AT SEA LEVEL				2096 KG	MID CG			
	PHI	THETA	PSI	ALPHA	BETA	GAMMA	ΘHR	B1S	A1S	ΘTR	
	-3.26	-2.80	0.15	-2.81	0.01	0.00	13.76	3.69	-0.02	5.09	
	XDOT		ZDOT	U0	V0	W0	VT0				
	51.44		0.00	51.38	0.01	-2.52	51.44				
	U	W	Q	V	P	R	DC	DB	DA	DP	
X	-0.0524	0.0269	0.5652	0.0013	-0.1618	-0.0305	-0.0130	0.0883	-0.0066	-0.0111	
Z	0.0026	-0.9441	-0.0451	0.0097	-0.6807	0.5150	-1.6683	0.4034	0.0685	0.0092	
M	0.0601	0.0821	-3.6032	-0.0055	-1.0170	0.0396	0.3979	-0.4312	0.0574	0.0341	
Y	0.0101	-0.0083	-0.1336	-0.1265	-0.6283	0.1797	-0.0275	0.0107	0.0994	-0.2355	
L'	-0.0269	-0.0601	2.4600	-0.2640	-9.0127	-0.0095	-0.1938	0.1879	1.0451	-0.4828	
M'	-0.0177	-0.0107	0.2566	0.0932	-0.0359	-0.6641	0.1442	0.0180	0.0052	0.6579	

TABLE III-3 CONTINUED
 BO-105C STABILITY AND CONTROL DERIVATIVES -- SI UNITS
 (BODY-FIXED FRL AXIS SYSTEM)

CASE 36	120 KT		LEVEL FLIGHT AT SEA LEVEL			2096 KG	MID CG			
	PHI	THETA	PSI	ALPHA	BETA	GAMMA	ΘMR	B1S	A1S	ΘTR
	-8.34	-5.25	0.39	-5.26	0.01	0.00	15.56	5.07	-0.09	6.30
	XDOT		ZDOT	U0	V0	W0	VT0			
	61.73		0.00	61.47	0.01	-5.66	61.73			
	U	W	Q	V	P	R	DC	DB	DA	DP
X	-0.0650	0.0209	0.5069	0.0014	-0.2098	-0.0409	-0.0315	0.0970	-0.0029	-0.0095
Z	0.0210	-0.9986	-0.1570	0.0061	-0.8304	0.6014	-1.7992	0.4969	0.0887	0.0141
M	0.0704	0.1259	-3.6633	-0.0050	-1.1000	0.0566	0.4979	-0.4630	0.0520	0.0493
Y	0.0126	-0.0052	-0.1919	-0.1462	-0.5315	0.2451	-0.0344	0.0095	0.1061	-0.2416
L*	-0.0317	-0.0727	2.4900	-0.2978	-8.7458	0.1204	-0.2402	0.1880	1.0605	-0.4974
M*	-0.0229	0.0065	0.3165	0.0947	-0.0070	-0.8654	0.2216	0.0025	0.0011	0.6752

CASE 37	145 KT		LEVEL FLIGHT AT SEA LEVEL			2096 KG	MID CG			
	PHI	THETA	PSI	ALPHA	BETA	GAMMA	ΘMR	B1S	A1S	ΘTR
	-6.30	-8.75	0.96	-8.80	0.00	0.00	19.14	7.75	-0.30	10.17
	XDOT		ZDOT	U0	V0	W0	VT0			
	74.59		0.00	73.72	0.01	-11.41	74.59			
	U	W	Q	V	P	R	DC	DB	DA	DP
X	-0.0816	0.0269	0.1715	0.0003	-0.3670	-0.0854	-0.0151	0.1040	-0.0103	-0.0073
Z	0.0363	-1.0427	-0.4021	-0.0028	-1.1458	0.8171	-1.9490	0.6129	0.1226	0.0314
M	0.0871	0.1623	-3.5179	0.0001	-1.1450	0.0512	0.6085	-0.5084	0.0339	0.0986
Y	0.0158	-0.0205	-0.2763	-0.1734	-0.3146	0.2351	-0.0717	0.0095	0.1190	-0.2434
L*	-0.0296	-0.1367	2.5280	-0.3646	-8.3443	0.1336	-0.3890	0.2054	1.0921	-0.5056
M*	-0.0234	0.1376	-0.1268	0.0922	-0.0713	-0.9315	0.5558	-0.0631	0.0113	0.6804

CASE 38	0 KT		LEVEL FLIGHT			1524 M	2096 KG	MID CG			
	PHI	THETA	PSI	ALPHA	BETA	GAMMA	ΘMR	B1S	A1S	ΘTR	
	-3.11	2.64	0.00	2.64	-0.14	0.00	15.21	-0.46	-0.30	11.42	
	XDOT		ZDOT	U0	V0	W0	VT0				
	0.00		0.00	0.00	0.00	0.00	0.00				
	U	W	Q	V	P	R	DC	DB	DA	DP	
X	-0.0189	0.0135	0.4649	0.0013	-0.1460	-0.0222	0.0444	0.0939	-0.0032	-0.0135	
Z	0.0094	-0.2937	-0.0008	-0.0018	0.0360	0.5342	-1.0509	0.0037	-0.0024	0.0017	
M	0.0738	-0.0028	-3.7094	-0.0192	-0.8400	0.0303	-0.0274	-0.3750	0.0805	0.0229	
Y	-0.0039	-0.0016	-0.2092	-0.0351	-0.5191	0.0608	-0.0089	0.0011	0.0942	-0.1799	
L*	-0.0560	-0.0031	2.3000	-0.2315	-10.0928	-0.2295	-0.0605	0.2068	1.0116	-0.3641	
M*	0.0030	0.0106	0.0954	0.0356	-0.0717	-0.3352	0.2471	0.0039	0.0186	0.5013	

TABLE III-3 CONTINUED
 B0-105C STABILITY AND CONTROL DERIVATIVES-- SI UNITS
 (BODY-FIXED FRL AXIS SYSTEM)

CASE	39	100 KT	LEVEL FLIGHT	1524 M	2096 KG	MID CG				
	PHI	THETA	PSI	ALPHA	BETA	GAMMA	ΘHR	BIS	AIS	ΘTR
	-3.01	-2.06	0.11	-2.06	0.00	0.00	14.29	4.06	0.02	5.62
	XDOT	ZDOT	UO	VO	WO	VTO				
	51.44	0.00	51.41	0.00	-1.85	51.44				
	U	W	Q	V	P	R	DC	DB	DA	DP
X	-0.0487	0.0171	0.6700	0.0026	-0.0959	-0.0291	-0.0245	0.0891	-0.0103	-0.0096
Z	-0.0014	-0.8113	-0.1179	0.0075	-0.6438	0.5344	-1.4399	0.3462	0.0615	0.0090
H	0.0624	0.0866	-4.0035	-0.0109	-1.0170	0.0429	0.3965	-0.4236	0.0738	0.0348
Y	0.0072	-0.0085	-0.0751	-0.1125	-0.6745	0.2005	-0.0317	0.0144	0.0958	-0.2097
L'	-0.0432	-0.0775	2.4600	-0.2639	-9.9772	-0.0392	-0.2706	0.2386	1.0162	-0.4304
N'	-0.0152	-0.0196	0.3631	0.0814	-0.0511	-0.7441	0.1386	0.0186	0.0035	0.5858

CASE	40	0 KT	LEVEL FLIGHT	3048 M	2096 KG	MID CG				
	PHI	THETA	PSI	ALPHA	BETA	GAMMA	ΘHR	BIS	AIS	ΘTR
	-3.36	2.58	0.00	2.58	-0.15	0.00	16.25	-0.49	-0.34	13.40
	XDOT	ZDOT	UO	VO	WO	VTO				
	0.00	0.00	0.00	0.00	0.00	0.00				
	U	W	Q	V	P	R	DC	DB	DA	DP
X	-0.0225	0.0099	0.5665	0.0023	-0.1365	-0.0426	0.0402	0.0941	-0.0048	-0.0123
Z	0.0089	-0.2617	0.0035	-0.0036	-0.1133	0.5083	-0.9265	0.0044	-0.0023	-0.0018
H	0.0806	-0.0016	-4.1245	-0.0223	-0.8400	0.0405	-0.0254	-0.3615	0.0972	0.0269
Y	-0.0033	-0.0023	-0.0803	-0.0366	-0.4082	0.0735	-0.0075	0.0053	0.0946	-0.1667
L'	-0.0742	-0.0071	2.3000	-0.2526	-8.1107	-0.2647	-0.0658	0.2636	0.9801	-0.3361
N'	-0.0002	0.0089	-0.0051	0.0285	-0.1633	-0.4153	0.2556	0.0037	0.0161	0.4652

CASE	41	100 KT	LEVEL FLIGHT	3048 M	2096 KG	MID CG				
	PHI	THETA	PSI	ALPHA	BETA	GAMMA	ΘHR	BIS	AIS	ΘTR
	-2.83	-1.32	0.06	-1.32	0.00	0.00	14.91	4.63	0.12	6.16
	XDOT	ZDOT	UO	VO	WO	VTO				
	51.44	0.00	51.43	0.00	-1.18	51.44				
	U	W	Q	V	P	R	DC	DB	DA	DP
X	-0.0424	0.0127	0.7483	0.0039	-0.0141	-0.0274	-0.0192	0.0859	-0.0110	-0.0083
Z	-0.0055	-0.6917	-0.1738	0.0061	-0.5262	0.4866	-1.2316	0.2992	0.0543	0.0099
H	0.0581	0.0858	-4.4079	-0.0183	-1.0170	0.0081	0.3775	-0.4069	0.0910	0.0354
Y	0.0047	-0.0100	-0.0894	-0.1020	-0.7570	0.1086	-0.0347	0.0147	0.0893	-0.1841
L'	-0.0474	-0.1025	2.4600	-0.2600	-11.0415	-0.2773	-0.3549	0.2893	0.9711	-0.3782
N'	-0.0117	-0.0161	0.6095	0.0767	0.1168	-0.5041	0.1650	0.0204	0.0030	0.5142

TABLE III-3 CONTINUED
 BO-105C STABILITY AND CONTROL DERIVATIVES -- SI UNITS
 (BODY-FIXED FRL AXIS SYSTEM)

CASE 42	10 KT			5 M/S			SEA LEVEL	2096 KG	MID CG	
PRI	THETA	PSI	ALPHA	BETA	GAMMA	ΘMR	B1S	A1S	ΘTR	
-3.56	2.59	0.00	2.59	-0.16	0.00	15.44	-0.49	-0.38	11.57	
IDOT		ZDOT	UO	VO	WO	VTO				
0.00		-5.08	0.23	0.32	-5.06	5.08				
U	W	Q	V	P	R	DC	DB	DA	DP	
X	-0.0254	0.0166	0.3893	-0.0001	-0.2709	-0.0357	0.0510	0.1005	0.0022	-0.0163
Z	0.0176	-0.4178	0.0158	-0.0075	-0.0178	0.5533	-1.1963	0.0040	0.0035	0.0006
H	0.0720	-0.0076	-3.2693	-0.0151	-0.8400	0.0484	-0.0308	-0.3882	0.0642	0.0278
Y	-0.1314	0.0083	-0.3162	-0.7210	-0.4676	0.0810	-0.0732	-0.0049	0.0986	-0.1993
L*	-0.0538	-0.0151	2.3000	-0.2675	-9.1836	-0.1779	-0.0790	0.1694	1.0499	-0.4036
M*	0.0086	0.0309	0.2104	0.0655	-0.0109	-0.3057	0.2837	0.0094	0.0228	0.5557

CASE 43	10 KT			-5 M/S			SEA LEVEL	2096 KG	MID CG	
PRI	THETA	PSI	ALPHA	BETA	GAMMA	ΘMR	B1S	A1S	ΘTR	
-2.51	2.58	0.00	2.57	-0.11	0.00	13.44	-0.42	-0.27	8.74	
IDOT		ZDOT	UO	VO	WO	VTO				
0.00		5.08	-0.23	-0.22	5.07	5.08				
U	W	Q	V	P	R	DC	DB	DA	DP	
X	-0.0176	0.0113	0.5642	0.0005	-0.1858	-0.0213	0.0527	0.0954	-0.0051	-0.0127
Z	0.0013	-0.2624	0.0804	0.0048	0.0531	0.4487	-1.1908	0.0068	0.0002	0.0010
H	0.0671	-0.0057	-3.4235	-0.0146	-0.8400	0.0282	-0.0313	-0.3828	0.0683	0.0157
Y	0.0515	0.0016	-0.2696	0.4420	-0.7040	0.1970	-0.0473	0.0080	0.0980	-0.1877
L*	-0.0526	0.0015	2.3000	-0.1922	-9.5464	0.0441	-0.0400	0.1903	1.0414	-0.3816
M*	0.0139	-0.0118	0.2864	0.0327	0.1299	-0.6473	0.1841	-0.0047	0.0104	0.5230

CASE 44	60 KT			5 M/S			SEA LEVEL	2096 KG	MID CG	
PRI	THETA	PSI	ALPHA	BETA	GAMMA	ΘMR	B1S	A1S	ΘTR	
-2.82	0.46	0.45	-9.03	-0.01	0.00	14.36	2.14	-0.16	7.23	
IDOT		ZDOT	UO	VO	WO	VTO				
30.45		-5.08	30.48	-0.00	-4.84	30.87				
U	W	Q	V	P	R	DC	DB	DA	DP	
X	-0.0424	0.0265	0.5248	0.0008	-0.1935	-0.0297	0.0101	0.0931	-0.0038	-0.0127
Z	-0.0420	-0.7741	0.1169	0.0063	-0.2977	0.5308	-1.4006	0.2144	0.0339	0.0098
H	0.0845	0.0605	-3.4486	-0.0070	-0.9460	0.0402	0.1797	-0.3953	0.0653	0.0377
Y	0.0053	-0.0031	-0.2002	-0.0985	-0.5734	0.1713	-0.0186	0.0057	0.1002	-0.2091
L*	-0.0435	-0.0165	2.3950	-0.2635	-9.1673	-0.0112	-0.1322	0.1846	1.0473	-0.4286
M*	-0.0178	0.0087	0.2174	0.0840	-0.0758	-0.6354	0.2071	0.0036	0.0097	0.5835

TABLE III-3 CONTINUED
 BO-105C STABILITY AND CONTROL DERIVATIVES -- SI UNITS
 (BODY-FIXED FRL AXIS SYSTEM)

CASE 45	60 KT			-5 M/S			SEA LEVEL	2096 KG	MID CG	
	PHI	THETA	PSI	ALPHA	BETA	GAMMA	ΘHR	B1S	A1S	ΘTR
	-1.16	0.70	-0.21	10.17	-0.00	0.00	10.11	1.48	0.09	2.73
	XDOT		ZDOT	UO		VO	WO	VTO		
	30.45		5.08	30.38		-0.00	5.45	30.87		
	U	W	Q	V	P	R	DC	DB	DA	DP
X	-0.0296	0.0277	0.7998	0.0016	-0.0340	-0.0128	0.0206	0.0780	-0.0172	-0.0136
Z	-0.0671	-0.7936	-0.0305	0.0075	-0.3593	0.3421	-1.3541	0.2105	0.0330	0.0006
H	0.0424	0.0384	-3.6705	-0.0055	-0.9460	0.0108	0.2157	-0.3888	0.0718	0.0179
Y	0.0019	-0.0098	-0.0096	-0.0867	-0.8352	0.0730	-0.0136	0.0173	0.0862	-0.2060
L'	-0.0371	-0.0213	2.3950	-0.1909	-9.5188	-0.2480	-0.1105	0.2006	1.0161	-0.4207
M'	-0.0103	-0.0727	0.1501	0.0854	-0.0354	-0.3637	0.0347	0.0238	0.0116	0.5748

CASE 46	100 KT			5 M/S			SEA LEVEL	2096 KG	MID CG	
	PHI	THETA	PSI	ALPHA	BETA	GAMMA	ΘHR	B1S	A1S	ΘTR
	-3.98	-2.72	0.57	-8.40	0.01	0.00	15.99	4.42	-0.21	7.50
	XDOT		ZDOT	UO		VO	WO	VTO		
	51.19		-5.08	50.89		0.01	-7.52	51.44		
	U	W	Q	V	P	R	DC	DB	DA	DP
X	-0.0584	0.0199	0.4803	0.0019	-0.1937	-0.0079	-0.0133	0.0983	-0.0019	-0.0111
Z	0.0068	-0.9333	-0.0872	0.0046	-0.7695	0.6082	-1.6644	0.3950	0.0696	0.0147
H	0.0793	0.1029	-3.6322	-0.0061	-1.0170	0.0253	0.3832	-0.4363	0.0576	0.0549
Y	0.0119	-0.0025	-0.2137	-0.1327	-0.4785	0.2475	-0.0299	0.0066	0.1092	-0.2338
L'	-0.0267	-0.0638	2.4600	-0.3028	-8.8091	0.1580	-0.2139	0.1875	1.0663	-0.4812
M'	-0.0215	0.0281	0.2076	0.0929	-0.0790	-0.8435	0.2569	-0.0056	0.0012	0.6531

CASE 47	100 KT			-5 M/S			SEA LEVEL	2096 KG	MID CG	
	PHI	THETA	PSI	ALPHA	BETA	GAMMA	ΘHR	B1S	A1S	ΘTR
	-2.44	-2.92	-0.12	2.75	0.00	0.00	11.42	2.74	0.17	3.19
	XDOT		ZDOT	UO		VO	WO	VTO		
	51.19		5.08	51.39		0.00	2.47	51.44		
	U	W	Q	V	P	R	DC	DB	DA	DP
X	-0.0473	0.0231	0.7082	0.0009	-0.0878	-0.0130	-0.0150	0.0805	-0.0133	-0.0138
Z	-0.0039	-0.9441	0.0063	0.0142	-0.6617	0.3297	-1.6703	0.4056	0.0680	0.0038
H	0.0402	0.0886	-3.6571	-0.0035	-1.0170	0.0345	0.4011	-0.4264	0.0607	0.0234
Y	0.0070	-0.0177	-0.1018	-0.1224	-0.7600	0.1531	-0.0248	0.0156	0.0887	-0.2368
L'	-0.0269	-0.0555	2.4600	-0.2233	-9.1746	0.0543	-0.1789	0.1932	1.0227	-0.4842
M'	-0.0061	-0.0520	0.4534	0.0982	0.0951	-0.5513	0.0316	0.0395	0.0117	0.6609

TABLE III-3 CONTINUED
 BO-105C STABILITY AND CONTROL DERIVATIVES -- SI UNITS
 (BODY-FIXED FRL AXIS SYSTEM)

CASE 48	0 KT		LEVEL FLIGHT AT SEA LEVEL			2096 KG	AFT CG			
	PHI	THETA	PSI	ALPHA	BETA	GAMMA	QMR	B1S	A1S	QTR
	-2.94	3.47	0.00	3.47	-0.18	0.00	14.33	0.24	-0.46	10.34
	XDOT		ZDOT	UO	VO	WO	VTO			
	0.00		0.00	0.00	0.00	0.00	0.00			
	U	W	Q	V	P	R	DC	DB	DA	DP
X	-0.0174	0.0189	0.4802	0.0011	-0.1833	-0.0421	0.0691	0.0949	-0.0029	-0.0145
Z	0.0187	-0.3301	0.0326	-0.0072	-0.0646	0.4862	-1.1852	0.0048	-0.0011	-0.0003
M	0.0658	0.0113	-3.3788	-0.0129	-0.8400	0.0439	0.0284	-0.3839	0.0642	0.0229
Y	-0.0001	-0.0019	-0.1638	-0.0319	-0.4574	0.0530	-0.0088	0.0031	0.0964	-0.1970
L'	-0.0347	-0.0025	2.3000	-0.2073	-9.0283	-0.3233	-0.0564	0.1788	1.0384	-0.3996
M'	-0.0035	0.0001	-0.2183	0.0304	-0.3382	-0.3098	0.2217	-0.0007	0.0190	0.5357

CASE 49	100 KT		LEVEL FLIGHT AT SEA LEVEL			2096 KG	AFT CG			
	PHI	THETA	PSI	ALPHA	BETA	GAMMA	QMR	B1S	A1S	QTR
	-3.27	-1.99	0.11	-1.99	0.01	0.00	13.69	4.29	-0.13	5.26
	XDOT		ZDOT	UO	VO	WO	VTO			
	51.44		0.00	51.41	0.00	-1.79	51.44			
	U	W	Q	V	P	R	DC	DB	DA	DP
X	-0.0526	0.0365	0.5661	0.0016	-0.1481	-0.0389	0.0095	0.0827	-0.0078	-0.0107
Z	0.0127	-0.9421	0.0713	0.0061	-0.6964	0.5030	-1.6687	0.4048	0.0681	0.0093
M	0.0541	0.1258	-3.6141	-0.0056	-1.0170	0.0356	0.4891	-0.4537	0.0537	0.0342
Y	0.0102	-0.0076	-0.1401	-0.1262	-0.6315	0.1703	-0.0297	0.0100	0.0975	-0.2354
L'	-0.0269	-0.0560	2.4600	-0.2625	-9.0075	-0.1213	-0.1974	0.1867	1.0412	-0.4827
M'	-0.0147	-0.0081	0.1533	0.0844	-0.0931	-0.6449	0.1405	0.0208	0.0156	0.6411

CASE 50	0 KT		LEVEL FLIGHT AT SEA LEVEL			2096 KG	FWD CG			
	PHI	THETA	PSI	ALPHA	BETA	GAMMA	QMR	B1S	A1S	QTR
	-3.01	2.02	0.00	2.02	-0.11	0.00	14.32	-0.90	-0.23	10.07
	XDOT		ZDOT	UO	VO	WO	VTO			
	0.00		0.00	0.00	0.00	0.00	0.00			
	U	W	Q	V	P	R	DC	DB	DA	DP
X	-0.0164	0.0107	0.4920	0.0002	-0.2210	-0.0323	0.0413	0.0971	-0.0018	-0.0144
Z	0.0016	-0.3352	-0.0146	-0.0011	-0.0383	0.4251	-1.1838	0.0053	0.0028	0.0002
M	0.0654	-0.0191	-3.3795	-0.0135	-0.8400	0.0823	-0.0758	-0.3845	0.0617	0.0221
Y	-0.0019	-0.0043	-0.2058	-0.0329	-0.5030	0.0878	-0.0045	0.0021	0.0942	-0.1963
L'	-0.0384	-0.0156	2.3000	-0.2074	-8.9592	-0.0568	-0.0486	0.1756	1.0160	-0.3982
M'	-0.0020	0.0075	0.1402	0.0336	-0.0298	-0.3375	0.2232	0.0037	0.0145	0.5563

TABLE III-3 CONTINUED
 B0-105C STABILITY AND CONTROL DERIVATIVES -- SI UNITS
 (BODY-FIXED FRL AXIS SYSTEM)

CASE 51 100 KT LEVEL FLIGHT AT SEA LEVEL 2096 KG FWD CG

	PHI	THETA	PSI	ALPHA	BETA	GAMMA	ΘMR	B1S	A1S	ΘTR
	-3.27	-3.43	0.19	-3.43	0.01	0.00	13.81	3.23	0.06	5.01
		XDOT	ZDOT	U0	V0	W0		VT0		
		51.44	0.00	51.35	0.01	-3.08		51.44		
	U	W	Q	V	P	R	DC	DB	DA	DP
X	-0.0525	0.0193	0.5623	0.0012	-0.1795	-0.0236	-0.0298	0.0926	-0.0057	-0.0114
Z	-0.0039	-0.9443	-0.1227	0.0117	-0.6242	0.5288	-1.6690	0.4028	0.0691	0.0092
H	0.0621	0.0527	-3.6019	-0.0054	-1.0170	0.0390	0.3311	-0.4155	0.0599	0.0348
Y	0.0101	-0.0070	-0.1308	-0.1266	-0.6171	0.1859	-0.0270	0.0127	0.0998	-0.2356
L*	-0.0268	-0.0598	2.4600	-0.2624	-8.9286	0.0667	-0.1936	0.1914	1.0461	-0.4831
H*	-0.0189	-0.0179	0.3356	0.0987	-0.0034	-0.6769	0.1495	0.0123	-0.0003	0.6685

CASE 52 0 KT LEVEL FLIGHT AT SEA LEVEL 2300 KG MID CG

	PHI	THETA	PSI	ALPHA	BETA	GAMMA	ΘMR	B1S	A1S	ΘTR
	-2.97	2.59	0.00	2.59	-0.13	0.00	14.86	-0.46	-0.36	11.06
		XDOT	ZDOT	U0	V0	W0		VT0		
		0.00	0.00	0.00	0.00	0.00		0.00		
	U	W	Q	V	P	R	DC	DB	DA	DP
X	-0.0177	0.0140	0.4719	0.0000	-0.2257	-0.0320	0.0468	0.0948	-0.0009	-0.0134
Z	0.0074	-0.3069	0.0060	-0.0035	-0.0781	0.4157	-1.0986	0.0019	-0.0027	-0.0012
H	0.0694	-0.0043	-3.2978	-0.0118	-0.8400	0.0644	-0.0300	-0.3755	0.0629	0.0237
Y	-0.0027	-0.0016	-0.1946	-0.0338	-0.5151	0.0772	-0.0092	0.0027	0.0948	-0.1826
L*	-0.0395	-0.0023	2.3000	-0.2152	-8.7289	-0.1240	-0.0603	0.1678	0.9900	-0.3805
H*	0.0020	0.0069	0.0498	0.0383	-0.0403	-0.3804	0.2496	0.0021	0.0171	0.5482

CASE 53 100 KT LEVEL FLIGHT AT SEA LEVEL 2300 KG MID CG

	PHI	THETA	PSI	ALPHA	BETA	GAMMA	ΘMR	B1S	A1S	ΘTR
	-3.02	-2.31	0.12	-2.31	0.00	0.00	14.08	3.93	-0.03	5.37
		XDOT	ZDOT	U0	V0	W0		VT0		
		51.44	0.00	51.40	0.00	-2.07		51.44		
	U	W	Q	V	P	R	DC	DB	DA	DP
X	-0.0501	0.0205	0.5940	0.0017	-0.1557	-0.0251	-0.0214	0.0897	-0.0076	-0.0097
Z	0.0006	-0.8570	-0.0226	0.0089	-0.6205	0.4815	-1.5148	0.3675	0.0635	0.0075
H	0.0615	0.0818	-3.5477	-0.0058	-1.0170	0.0358	0.3957	-0.4247	0.0564	0.0346
Y	0.0086	-0.0091	-0.1316	-0.1174	-0.6425	0.1691	-0.0295	0.0112	0.0969	-0.2145
L*	-0.0304	-0.0587	2.4600	-0.2603	-8.5861	0.1137	-0.1945	0.1760	0.9901	-0.4525
H*	-0.0178	-0.0184	0.3062	0.0914	-0.0309	-0.6549	0.1472	0.0227	0.0079	0.6449

TABLE III-3 CONCLUDED
 BO-105C STABILITY AND CONTROL DERIVATIVES -- SI UNITS
 (BODY-FIXED FRL AXIS SYSTEM)

CASE	0 KT		LEVEL FLIGHT AT SEA LEVEL				1814 KG	MID CG		
	PHI	THETA	PSI	ALPHA	BETA	GAMMA	ΘHR	B1S	A1S	ΘTR
	-2.95	2.67	0.00	2.67	-0.14	0.00	13.51	-0.37	-0.28	9.15
	XDOT		ZDOT	U0	V0	W0	VT0			
	0.00		0.00	0.00	0.00	0.00	0.00			
	U	W	Q	V	P	R	DC	DB	DA	DP
X	-0.0170	0.0148	0.4775	0.0002	-0.2296	-0.0319	0.0629	0.0962	-0.0018	-0.0162
Z	0.0113	-0.3769	0.0326	-0.0045	-0.0538	0.3833	-1.3290	0.0070	0.0010	0.0003
M	0.0620	-0.0059	-3.4952	-0.0130	-1.0170	0.0613	-0.0329	-0.3951	0.0690	0.0205
Y	-0.0031	-0.0047	-0.2204	-0.0356	-0.5363	0.0911	-0.0070	0.0006	0.0968	-0.2208
L'	-0.0394	-0.0121	2.4600	-0.2075	-9.9053	-0.1824	-0.0503	0.1933	1.1206	-0.4274
M'	0.0042	0.0080	0.0403	0.0365	-0.0569	-0.3445	0.2032	0.0033	0.0189	0.5493

CASE	100 KT		LEVEL FLIGHT AT SEA LEVEL				1814 KG	MID CG		
	PHI	THETA	PSI	ALPHA	BETA	GAMMA	ΘHR	B1S	A1S	ΘTR
	-3.69	-3.77	0.24	-3.78	0.00	0.00	13.44	3.41	-0.01	4.94
	XDOT		ZDOT	U0	V0	W0	VT0			
	51.44		0.00	51.33	0.00	-3.39	51.44			
	U	W	Q	V	P	R	DC	DB	DA	DP
X	-0.0581	0.0358	0.5208	0.0007	-0.1862	-0.0263	0.0007	0.0870	-0.0053	-0.0132
Z	0.0107	-1.0924	-0.0948	0.0111	-0.7524	0.5546	-1.9340	0.4646	0.0780	0.0090
M	0.0573	0.0900	-3.7048	-0.0048	-1.0170	0.0433	0.4024	-0.4439	0.0592	0.0355
Y	0.0099	-0.0075	-0.1315	-0.1438	-0.6737	0.2938	-0.0292	0.0101	0.1017	-0.2729
L'	-0.0362	-0.0672	-2.4600	-0.2718	-9.7571	0.1412	-0.2060	0.2038	1.1295	-0.5334
M'	-0.0118	-0.0010	0.1656	0.0985	0.1494	-0.8804	0.1586	0.0090	0.0074	0.6800

TABLE III-4
BO-105C STABILITY AND CONTROL DERIVATIVES -- US UNITS
(BODY-FIXED FRL AXIS SYSTEM)

CASE	-20 KT		LEVEL FLIGHT AT SEA LEVEL				4620 LB	MID CG		
	PHI	THETA	PSI	ALPHA	BETA	GAMMA	ΘMR	B1S	A1S	ΘTR
CASE 27	-2.45	2.31	-0.09	-177.69	0.00	180.00	13.56	-1.36	-0.34	8.00
	XDOT	ZDOT	UO	VO	WO	VTO				
	-33.76	0.00	-33.73	0.00	-1.36	33.76				
	U	W	Q	V	P	R	DC	DR	DA	DP
X	-0.0270	0.0217	1.8605	0.0024	-0.5971	-0.0447	0.4872	0.8218	-0.0367	-0.1233
Z	0.2359	-0.4538	-0.3535	-0.0062	-0.1152	1.4166	-9.3170	-0.4693	-0.0989	-0.0395
M	0.0238	-0.0112	-3.4330	-0.0055	-0.8080	0.0206	-0.2710	-0.9826	0.1614	0.0332
Y	-0.0123	-0.0027	-0.7004	0.0047	-1.9843	0.5788	-0.0678	0.0262	0.7750	-1.4965
L*	-0.0221	-0.0008	2.2700	-0.0615	-9.3138	0.0622	-0.0341	0.4601	2.5671	-0.9253
N*	0.0103	-0.0001	0.1027	0.0110	-0.1038	-0.6328	0.4989	0.0151	0.0613	1.2716

CASE	-10 KT		LEVEL FLIGHT AT SEA LEVEL				4620 LB	MID CG		
	PHI	THETA	PSI	ALPHA	BETA	GAMMA	ΘMR	B1S	A1S	ΘTR
CASE 28	-2.80	2.37	-0.11	-177.63	0.01	180.00	14.16	-0.96	-0.34	9.54
	XDOT	ZDOT	UO	VO	WO	VTO				
	-16.88	0.00	-16.86	0.00	-0.70	16.88				
	U	W	Q	V	P	R	DC	DR	DA	DP
X	-0.0228	0.0160	1.7378	0.0020	-0.6781	-0.0992	0.4465	0.8257	-0.0245	-0.1214
Z	0.1508	-0.3510	-3.0895	-0.0067	0.0605	1.4892	-9.6070	-0.2205	-0.0433	-0.0146
M	0.0254	-0.0046	-3.4094	-0.0044	-0.8250	0.0469	-0.1739	-0.9810	0.1699	0.0434
Y	-0.0085	-0.0002	-0.5801	0.0677	-2.3636	0.2329	-0.0653	0.0025	0.7903	-1.5919
L*	-0.0223	0.0001	2.2850	-0.0599	-9.4074	-0.1780	-0.0970	0.4482	2.6329	-0.9837
N*	0.0082	-0.0010	-0.0363	0.0071	0.1066	-0.3465	0.5498	0.0232	0.0668	1.3531

CASE	0 KT		LEVEL FLIGHT AT SEA LEVEL				4620 LB	MID CG		
	PHI	THETA	PSI	ALPHA	BETA	GAMMA	ΘMR	B1S	A1S	ΘTR
CASE 29	-2.97	2.64	0.00	2.63	-0.14	0.00	14.32	-0.42	-0.33	10.17
	XDOT	ZDOT	UO	VO	WO	VTO				
	0.00	0.00	0.00	0.00	0.00	0.00				
	U	W	Q	V	P	R	DC	DR	DA	DP
X	-0.0166	0.0124	1.6105	0.0004	-0.7260	-0.1192	0.4467	0.7894	-0.0045	-0.1202
Z	0.0100	-0.3317	0.3300	-0.0010	0.1473	1.8309	-9.8810	0.0429	-0.0160	-0.0131
M	0.0202	-0.0027	-3.3972	-0.0040	-0.8400	0.0439	-0.0805	-0.9727	0.1598	0.0577
Y	-0.0012	-0.0054	-0.4814	-0.0120	-1.7454	0.2350	-0.0489	0.0341	0.8014	-1.6381
L*	-0.0111	-0.0121	2.1000	-0.0632	-9.2439	-0.2240	-0.1275	0.4590	2.6446	-1.0126
N*	-0.0008	0.0018	-0.1215	0.0099	-0.3759	-0.3270	0.5651	-0.0045	0.0341	1.3931

TABLE III-4 CONTINUED
 B0-105C STABILITY AND CONTROL DERIVATIVES -- US UNITS
 (BODY-FIXED FRL AXIS SYSTEM)

CASE	30	10 KT	LEVEL FLIGHT AT SEA LEVEL				4620 LB	MID CG			
	PHI	THETA	PSI	ALPHA	BETA	GAMMA	ΘMR	B1S	A1S	ΘTR	
	-2.76	2.27	-0.11	2.28	-0.00	0.00	14.12	-0.10	-0.28	9.70	
		XDOT	ZDOT	U0	V0	W0	VT0				
		16.89	0.00	16.86	-0.00	0.67	16.88				
	U	W	Q	V	P	R	DC	DB	DA	DP	
X	-0.0196	0.0148	1.7064	-0.0000	-0.5387	-0.0973	0.3234	0.7976	-0.0262	-0.1203	
Z	-0.1320	-0.3768	0.1521	0.0025	-0.1658	1.5316	-9.6200	0.3033	0.0325	0.0196	
M	0.0181	-0.0004	-3.4105	-0.0048	-0.3600	0.0494	0.0011	-0.9764	0.1713	0.0631	
Y	0.0037	-0.0045	-0.5234	-0.1259	-2.0897	0.4097	-0.0967	0.0092	0.8214	-1.5995	
L*	-0.0062	-0.0034	2.3180	-0.0698	-9.4386	0.0537	-0.1774	0.4416	2.6544	-0.9912	
N*	-0.0071	0.0024	-0.0601	0.0144	0.1119	-0.4741	0.5597	0.0204	0.0389	1.3596	

CASE	31	20 KT	LEVEL FLIGHT AT SEA LEVEL				4620 LB	MID CG			
	PHI	THETA	PSI	ALPHA	BETA	GAMMA	ΘMR	B1S	A1S	ΘTR	
	-2.41	2.07	-0.09	2.07	-0.00	0.00	13.56	0.33	-0.21	8.34	
		XDOT	ZDOT	U0	V0	W0	VT0				
		33.76	0.00	33.73	-0.00	1.22	33.76				
	U	W	Q	V	P	R	DC	DB	DA	DP	
X	-0.0154	0.0193	1.8376	-0.0004	-0.5561	-0.0988	0.2412	0.7813	-0.0437	-0.1088	
Z	-0.1978	-0.4699	0.0642	0.0021	-0.4538	1.3646	-9.3763	0.5217	0.0926	0.0012	
M	0.0204	0.0017	-3.4423	-0.0034	-0.9750	0.0590	0.0823	-0.9712	0.1638	0.0677	
Y	0.0093	-0.0026	-0.5687	-0.0725	-1.8036	0.0904	-0.0699	0.0663	0.8019	-1.5070	
L*	-0.0052	-0.0027	2.3300	-0.0681	-9.1973	-0.2979	-0.1675	0.4846	2.5864	-0.9357	
N*	-0.0119	-0.0014	0.1101	0.0166	-0.2249	-0.2290	0.4727	-0.0056	0.0274	1.2817	

CASE	32	40 KT	LEVEL FLIGHT AT SEA LEVEL				4620 LB	MID CG			
	PHI	THETA	PSI	ALPHA	BETA	GAMMA	ΘMR	B1S	A1S	ΘTR	
	-1.97	1.63	-0.06	1.53	-0.00	0.00	12.49	1.08	-0.10	5.75	
		XDOT	ZDOT	U0	V0	W0	VT0				
		67.51	0.00	67.49	-0.00	1.92	67.51				
	U	W	Q	V	P	R	DC	DB	DA	DP	
X	-0.0245	0.0253	2.1098	-0.0013	-0.4364	-0.0953	0.1651	0.7363	-0.0759	-0.1016	
Z	-0.1277	-0.6648	-0.0766	0.0023	-0.4479	1.0969	-10.1648	1.1113	0.1505	0.0269	
M	0.0223	0.0100	-3.4724	-0.0024	-0.9120	0.0647	0.2566	-0.9717	0.1781	0.0599	
Y	0.0044	-0.0091	-0.1847	-0.0779	-2.4374	0.2369	-0.0995	0.0980	0.7661	-1.5761	
L*	-0.0109	-0.0053	2.3659	-0.0680	-9.4976	-0.2971	-0.2119	0.4826	2.6113	-0.9801	
N*	-0.0058	-0.0031	-0.0142	0.0233	0.0114	-0.3490	0.3452	0.0088	0.0409	1.3407	

TABLE III-4 CONTINUED
BO-105C STABILITY AND CONTROL DERIVATIVES -- US UNITS
(BODY-FIXED FRL AXIS SYSTEM)

CASE	60 KT		LEVEL FLIGHT AT SEA LEVEL				4620 LB	MID CG		
	PHI	THETA	PSI	ALPHA	BETA	GAMMA	QMR	BIS	AIS	QTR
	-2.08	0.59	-0.02	0.59	-0.00	0.00	12.28	1.97	-0.06	4.77
	XDOT		ZDOT	UO	VO	WO	VTO			
	101.27		0.00	101.26	-0.01	1.05	101.27			
	U	W	Q	V	P	R	DC	DB	DA	DP
X	-0.0338	0.0311	2.0944	0.0014	-0.3731	-0.0640	0.1583	0.7017	-0.0875	-0.1034
Z	-0.0564	-0.7886	0.1852	0.0039	-0.9501	1.5967	-11.4355	1.7973	0.2775	0.0508
M	0.0179	0.0129	-3.6151	-0.0019	-0.9460	0.0252	0.5163	-0.9962	0.1735	0.0644
Y	0.0059	-0.0051	-0.3759	-0.0910	-2.3476	0.5933	-0.1493	0.0963	0.7716	-1.7346
L'	-0.0100	-0.0103	2.3950	-0.0689	-9.3541	-0.0251	-0.3060	0.4863	2.6151	-1.0815
N'	-0.0055	-0.0093	0.2080	0.0252	-0.0220	-0.6627	0.3055	0.0377	0.0293	1.4758

CASE	80 KT		LEVEL FLIGHT AT SEA LEVEL				4620 LB	MID CG		
	PHI	THETA	PSI	ALPHA	BETA	GAMMA	QMR	BIS	AIS	QTR
	-2.49	-0.86	0.03	-0.86	0.00	0.00	12.64	2.69	-0.01	4.54
	XDOT		ZDOT	UO	VO	WO	VTO			
	135.02		0.00	135.01	0.01	-2.02	135.02			
	U	W	Q	V	P	R	DC	DB	DA	DP
X	-0.0423	0.0292	2.0108	0.0012	-0.3987	-0.0302	0.0515	0.6957	-0.0802	-0.1035
Z	-0.0158	-0.8734	0.0168	0.0091	-1.7114	1.5317	-12.7138	2.5634	0.4154	0.0513
M	0.0153	0.0170	-3.6267	-0.0018	-0.9620	0.0246	0.7645	-1.0384	0.1623	0.0695
Y	0.0060	-0.0078	-0.5854	-0.1083	-2.2082	0.4332	-0.1889	0.0947	0.7739	-1.8813
L'	-0.0102	-0.0144	2.4250	-0.0734	-9.1897	-0.1203	-0.3989	0.4828	2.6183	-1.1738
N'	-0.0033	-0.0072	0.4221	0.0278	-0.0607	-0.5253	0.2952	0.0521	0.0298	1.6010

CASE	100 KT		LEVEL FLIGHT AT SEA LEVEL				4620 LB	MID CG		
	PHI	THETA	PSI	ALPHA	BETA	GAMMA	QMR	BIS	AIS	QTR
	-3.26	-2.80	0.15	-2.81	0.01	0.00	13.76	3.69	-0.02	5.09
	XDOT		ZDOT	UO	VO	WO	VTO			
	168.78		0.00	168.58	0.02	-8.27	168.78			
	U	W	Q	V	P	R	DC	DB	DA	DP
X	-0.0524	0.0269	1.8542	0.0013	-0.5307	-0.0999	-0.1082	0.7351	-0.0551	-0.0923
Z	0.0026	-0.9441	-0.1480	0.0097	-2.2311	1.6897	-13.9928	1.3620	0.5710	0.0764
M	0.0183	0.0250	-3.6012	-0.0017	-1.0170	0.0396	1.0107	-1.0953	0.1459	0.0866
Y	0.0101	-0.0083	-0.4384	-0.1265	-2.0613	0.5876	-0.2288	0.0892	0.8280	-1.9629
L'	-0.0082	-0.0193	2.4600	-0.0805	-9.0127	-0.0995	-0.4923	0.4772	2.6546	-1.2261
N'	-0.0054	-0.0033	0.2566	0.0288	-0.0359	-0.6641	0.3662	0.0456	0.0111	1.6710

TABLE III-4 CONTINUED
 B0-105C STABILITY AND CONTROL DERIVATIVES -- US UNITS
 (BODY-FIXED FRL AXIS SYSTEM)

CASE	16	120 KT	LEVEL FLIGHT AT SEA LEVEL			4620 LB	MID CG			
	PHI	THETA	PSI	ALPHA	BETA	GAMMA	ΘMP	BIS	AIS	ΘTR
	-4.14	-5.25	0.39	-5.26	0.01	0.00	15.56	5.07	-0.09	6.30
	XDOT	ZDOT	U0	V0	W0	VT0				
	202.54	0.00	201.68	0.04	-18.57	202.54				
	U	W	Q	V	P	R	DC	DB	DA	DP
X	-0.0650	0.0209	1.6631	0.0014	-0.6882	-0.1341	-0.2621	0.8080	-0.0244	-0.0791
Z	0.0210	-0.9986	-0.5151	0.0061	-2.7244	1.9730	-14.9931	4.1412	0.7392	0.1176
M	0.0215	0.0384	-3.6633	-0.0015	-1.1300	0.0566	1.2647	-1.1759	0.1320	0.1251
Y	0.0126	-0.0052	-0.6295	-0.1462	-1.7438	0.8042	-0.2867	0.0793	0.9846	-2.0135
L*	-0.0097	-0.0222	2.4900	-0.0908	-8.7458	0.1204	-0.6101	0.4774	2.6937	-1.2635
N*	-0.0070	0.0020	0.3165	0.0289	-0.0070	-0.8654	0.5629	0.0065	0.0027	1.7151

CASE	37	145 KT	LEVEL FLIGHT AT SEA LEVEL			4620 LB	MID CG			
	PHI	THETA	PSI	ALPHA	BETA	GAMMA	ΘMP	BIS	AIS	ΘTR
	-6.30	-8.75	0.96	-8.80	0.00	0.00	19.14	7.75	-0.30	10.17
	XDOT	ZDOT	U0	V0	W0	VT0				
	244.73	0.00	241.85	0.02	-37.44	244.73				
	U	W	Q	V	P	R	DC	DB	DA	DP
X	-0.0816	0.0269	0.5627	0.0003	-1.2041	-0.2802	-0.1260	0.8669	0.0862	-0.0609
Z	0.0363	-1.0427	-1.3191	-0.0028	-3.7592	2.6809	-16.2418	5.1074	1.0219	0.2614
M	0.0265	0.0495	-3.5179	0.0000	-1.1450	0.0512	1.5456	-1.2913	0.0861	0.2505
Y	0.0158	-0.0205	-0.9064	-0.1734	-1.0320	0.7712	-0.5978	0.0792	0.9919	-2.0282
L*	-0.0090	-0.0417	2.5280	-0.1111	-8.3443	0.1336	-0.9980	0.5217	2.7738	-1.2841
N*	-0.0071	0.0419	-0.1268	0.0281	-0.0713	-0.9315	1.4117	-0.1603	0.0286	1.7283

CASE	38	0 KT	LEVEL FLIGHT	5000 FT	4620 LB	MID CG				
	PHI	THETA	PSI	ALPHA	BETA	GAMMA	ΘMP	BIS	AIS	ΘTR
	-3.11	2.64	0.00	2.64	-0.14	0.00	15.21	-0.46	-0.30	11.42
	XDOT	ZDOT	U0	V0	W0	VT0				
	0.00	0.00	0.00	0.00	0.00	0.00				
	U	W	Q	V	P	R	DC	DB	DA	DP
X	-0.0189	0.0135	1.5254	0.0013	-0.4791	-0.0727	0.3701	0.7828	-0.0266	-0.1128
Z	0.0094	-0.2937	-0.0027	-0.0018	0.1183	1.7528	-8.7571	0.0310	-0.0198	0.0145
M	0.0225	-0.0009	-3.7094	-0.0059	-0.8400	0.0303	-0.0697	-0.9525	0.2045	0.0581
Y	-0.0039	-0.0016	-0.6853	-0.0351	-1.7030	0.1996	-0.0738	0.0094	0.7853	-1.4989
L*	-0.0171	-0.0010	2.3090	-0.0706	-10.0928	-0.2295	-0.1536	0.5253	2.5695	-0.9249
N*	0.0009	0.0012	0.0954	0.0169	-0.0717	-0.3352	0.6276	0.0094	0.0472	1.2732

TABLE III-4 CONTINUED
BO-105C STABILITY AND CONTROL DERIVATIVES -- US UNITS
(BODY-FIXED FRL AXIS SYSTEM)

CASE	39	100 KT	LEVEL FLIGHT	5000 FT	4620 LB	MID CG				
	PHI	THETA	PSI	ALPHA	BETA	GAMMA	ΘMR	β1S	α1S	θTR
	-3.01	-2.06	0.11	-2.06	0.00	0.00	14.29	4.06	0.02	5.62
	XDOT	ZDOT	U0	V0	W0	VT0				
	168.78	0.00	168.67	0.00	-6.09	168.78				
	U	W	Q	V	P	R	DC	DB	DA	DP
X	-0.0487	0.0171	2.1983	0.0026	-0.3145	-0.0954	-0.2040	0.7422	-0.0859	-0.0797
Z	-0.0014	-0.8113	-0.3867	0.0075	-2.1122	1.7534	-11.9988	2.8851	0.5128	0.0746
M	0.0190	0.0264	-4.0035	-0.0033	-1.0170	0.0429	1.0071	-1.0759	0.1873	0.0885
Y	0.0072	-0.0085	-0.2464	-0.1125	-2.2130	0.6576	-0.2642	0.1201	0.7984	-1.7475
L'	-0.0132	-0.0236	2.4600	-0.0804	-9.9772	-0.0392	-0.6874	0.6060	2.5811	-1.0933
N'	-0.0046	-0.0060	0.3631	0.0248	-0.0511	-0.7441	0.3521	0.0471	0.0090	1.4880

CASE	40	0 KT	LEVEL FLIGHT	10000 FT	4620 LB	MID CG				
	PHI	THETA	PSI	ALPHA	BETA	GAMMA	ΘMR	β1S	α1S	θTR
	-3.36	2.58	0.00	2.58	-0.15	0.00	16.25	-0.49	-0.34	13.40
	XDOT	ZDOT	U0	V0	W0	VT0				
	0.00	0.00	0.00	0.00	0.00	0.00				
	U	W	Q	V	P	R	DC	DB	DA	DP
X	-0.0225	0.0099	1.8587	0.0023	-0.4477	-0.1396	0.3351	0.7844	-0.0397	-0.1022
Z	0.0089	-0.2617	0.0116	-0.0036	-0.3716	1.6675	-7.7207	0.0368	-0.0195	-0.0154
M	0.0246	-0.0005	-4.1245	-0.0068	-0.9400	0.0405	-0.0645	-0.9192	0.2469	0.0682
Y	-0.0033	-0.0023	-0.2635	-0.0366	-1.3393	0.2412	-0.0625	0.0445	0.7883	-1.3889
L'	-0.0226	-0.0022	2.3000	-0.0770	-8.1107	-0.2647	-0.1672	0.6696	2.4894	-0.8538
N'	-0.0001	0.0027	-0.0051	0.0087	-0.1633	-0.4153	0.6491	0.0095	0.0408	1.1816

CASE	41	100 KT	LEVEL FLIGHT	10000 FT	4620 LB	MID CG				
	PHI	THETA	PSI	ALPHA	BETA	GAMMA	ΘMR	β1S	α1S	θTR
	-2.83	-1.32	0.06	-1.12	0.00	0.00	14.91	4.63	0.12	6.16
	XDOT	ZDOT	U0	V0	W0	VT0				
	168.78	0.00	168.74	0.01	-3.88	168.78				
	U	W	Q	V	P	R	DC	DB	DA	DP
X	-0.0424	0.0127	2.4552	0.0019	-0.0452	-0.0997	-0.1602	0.7158	-0.1079	-0.0693
Z	-0.0055	-0.6917	-0.5703	0.0061	-1.7262	1.5964	-10.2630	2.4930	0.4527	0.0824
M	0.0177	0.0261	-4.4079	-0.0056	-1.0170	0.0081	0.9589	-1.0335	0.2311	0.0898
Y	0.0047	-0.0100	-0.2133	-0.1020	-2.4838	0.3562	-0.2890	0.1224	0.7441	-1.5333
L'	-0.0144	-0.0312	2.4600	-0.0817	-11.3435	-0.2773	-0.9014	0.7349	2.4716	-0.9605
N'	-0.0036	-0.0050	0.6535	0.0234	0.1164	-0.5141	0.4190	0.0518	0.0076	1.3060

C-2

TABLE III-4 CONTINUED
BO-105C STABILITY AND CONTROL DERIVATIVES -- US UNITS
(BODY-FIXED FRL AXIS SYSTEM)

CASE	42	10 KT	1000 FT/MIN	SEA LEVEL	4620 LB	MID CG				
	PHI	THETA	PSI	ALPHA	BETA	GAMMA	QMR	BIS	AIS	QTR
	-1.56	2.59	0.00	2.59	-0.16	0.00	15.44	-0.49	-0.38	11.57
	XDOT	ZDOT	UO	VO	WO	VT0				
	0.00	-16.67	0.75	1.03	-16.62	16.67				
	U	W	Q	V	P	R	DC	DB	DA	DP
X	-0.0254	0.0166	1.2773	-0.0001	-0.8887	-0.1171	0.4252	0.8375	0.0184	-0.1355
Z	0.0176	-0.4173	0.0519	-0.0075	-0.0584	1.8152	-9.9689	0.0337	0.0289	0.0048
N	0.0219	-0.0023	-3.2593	-0.0046	-0.8400	3.0484	-0.0782	-0.9859	0.1631	0.0707
Y	-0.1314	0.0083	-1.0374	-0.7210	-1.5340	0.2657	-0.6102	-0.0411	0.8219	-1.6609
L'	-0.0164	-0.0046	2.3000	-0.0815	-9.1836	-0.1779	-0.2006	0.4303	2.6668	-1.0250
N'	0.0026	0.0094	0.2104	0.0200	-0.0109	-0.3057	0.7207	0.0238	0.0579	1.4114

CASE	43	10 KT	-1000 FT/MIN	SEA LEVEL	4620 LB	MID CG				
	PHI	THETA	PSI	ALPHA	BETA	GAMMA	QMR	BIS	AIS	QTR
	-2.51	2.58	0.00	2.57	-0.11	0.00	13.44	-0.42	-0.27	8.74
	XDOT	ZDOT	UO	VO	WO	VT0				
	0.00	16.67	-0.75	-0.73	16.63	16.67				
	U	W	Q	V	P	R	DC	DB	DA	DP
X	-0.0176	0.0113	1.8511	0.0005	-0.6095	-0.0700	0.4390	0.7951	-0.0425	-0.1059
Z	0.0013	-0.2624	0.2639	0.0048	0.1742	1.4722	-9.9233	0.0570	0.0021	0.0085
N	0.0205	-0.0017	-3.4235	-0.0044	-0.8400	0.0282	-0.0795	-0.9723	0.1734	0.0398
Y	0.0515	0.0016	-0.8845	0.4420	-2.3097	0.6463	-0.3939	0.0667	0.8168	-1.5639
L'	-0.0160	0.0005	2.3000	-0.0586	-9.5464	0.0441	-0.1015	0.4834	2.6453	-0.9693
N'	0.0042	-0.0036	0.2964	0.0100	0.1299	-0.6473	0.4675	-0.0120	0.0263	1.3283

CASE	44	60 KT	1000 FT/MIN	SEA LEVEL	4620 LB	MID CG				
	PHI	THETA	PSI	ALPHA	BETA	GAMMA	QMR	BIS	AIS	QTR
	-2.82	0.46	0.45	-9.03	-0.01	0.00	14.36	2.14	-0.16	7.23
	XDOT	ZDOT	UO	VO	WO	VT0				
	99.89	-16.67	100.01	-0.01	-15.89	101.27				
	U	W	Q	V	P	R	DC	DB	DA	DP
X	-0.0424	0.0265	1.7217	0.0008	-0.6343	-0.0975	0.0843	0.7759	-0.0315	-0.1058
Z	-0.0420	-0.7741	0.3836	0.0063	-0.9769	1.7414	-11.6717	1.7871	0.2821	0.0820
N	0.0258	0.0184	-3.4486	-0.0021	-0.9460	0.0402	0.4565	-1.0042	0.1658	0.0958
Y	0.0053	-0.0031	-0.6589	-0.0985	-1.8812	0.5618	-0.1547	0.0473	0.9346	-1.7426
L'	-0.0133	-0.0111	2.3000	-0.0803	-9.1173	-0.0112	-0.3357	0.4690	2.6600	-1.0886
N'	-0.0054	0.0026	0.2174	0.0256	-0.0758	-0.6154	0.5260	0.0090	0.0247	1.4822

TABLE III-4 CONTINUED
 BO-105C STABILITY AND CONTROL DERIVATIVES -- US UNITS
 (BODY-FIXED FRL AXIS SYSTEM)

CASE	45	60 KT	-1000 FT/MIN	SEA LEVEL	4620 LB	MID CG						
	PHI	THETA	PSI	ALPHA	BETA	GAMMA	ΘMR	B1S	A1S	ΘTR		
	-1.16	0.70	-0.21	10.17	-0.00	0.00	10.11	1.48	0.09	2.73		
	XDOT	ZDOT	U0	V0	W0	VT0						
	99.87	16.67	99.68	-0.00	17.88	101.27						
	U	W	Q	V	P	R	DC	DB	DA	DP		
X	-0.0296	0.0277	2.6242	0.0016	-0.1114	-0.0420	0.1713	0.6502	-0.1436	-0.1132		
Z	-0.0671	-0.7936	-0.1901	0.0075	-1.1790	1.1225	-11.2840	1.7540	0.2754	0.0049		
M	0.0129	0.0117	-3.6705	-0.0017	-0.9460	0.0109	0.5480	-0.9875	0.1823	0.0455		
Y	0.0019	-0.0098	-0.0315	-0.0867	-2.7401	0.2396	-0.1133	0.1442	0.7185	-1.7169		
L*	-0.0113	-0.0065	2.3950	-0.0582	-0.5183	-0.2480	-0.2807	0.5095	2.5810	-1.0685		
N*	-0.0031	-0.0222	0.1501	0.0260	-0.3354	-0.3637	0.0881	0.0604	0.0294	1.4599		

CASE	46	100 KT	1000 FT/MIN	SEA LEVEL	4620 LB	MID CG						
	PHI	THETA	PSI	ALPHA	BETA	GAMMA	ΘMR	B1S	A1S	ΘTR		
	-3.98	-2.72	0.57	-8.40	0.01	0.00	15.99	4.42	-0.21	7.50		
	XDOT	ZDOT	U0	V0	W0	VT0						
	167.96	-16.67	166.97	0.03	-24.66	168.78						
	U	W	Q	V	P	R	DC	DB	DA	DP		
X	-0.0584	0.0199	1.5759	0.0019	-0.6354	-0.0260	-0.1110	0.8189	-0.0160	-0.0927		
Z	0.0068	-0.9333	-0.2862	0.0045	-2.5245	1.9953	-13.8700	3.2921	0.5798	0.1227		
M	0.0242	0.0314	-3.6322	-0.0018	-1.0170	0.0253	0.9734	-1.1082	0.1463	0.1394		
Y	0.0119	-0.0025	-0.7013	-0.1327	-1.5699	0.8122	-0.2492	0.0552	0.9096	-1.9482		
L*	-0.0081	-0.0195	2.4600	-0.0923	-8.8091	0.1580	-0.5432	0.4763	2.7083	-1.2221		
N*	-0.0066	0.0086	0.2076	0.0283	-0.0790	-0.8435	0.6526	-0.0143	0.0031	1.6589		

CASE	47	100 KT	-1000 FT/MIN	SEA LEVEL	4620 LB	MID CG						
	PHI	THETA	PSI	ALPHA	BETA	GAMMA	ΘMR	B1S	A1S	ΘTR		
	-2.44	-2.92	-0.12	2.75	0.00	0.00	11.42	2.74	0.17	3.19		
	XDOT	ZDOT	U0	V0	W0	VT0						
	167.96	16.67	168.59	0.01	8.10	168.78						
	U	W	Q	V	P	R	DC	DB	DA	DP		
X	-0.0473	0.0231	2.3235	0.0009	-0.2882	-0.0426	-0.1246	0.6712	-0.1104	-0.1153		
Z	-0.0039	-0.9441	0.0207	0.0142	-2.1708	1.9317	-13.9194	3.3801	0.5665	0.0317		
M	0.0122	0.0270	-3.6571	-0.0011	-1.0170	0.0345	1.0187	-1.0832	0.1541	0.0595		
Y	0.0070	-0.0177	-0.3319	-0.1224	-2.4910	0.5924	-0.2064	0.1302	0.7192	-1.9730		
L*	-0.0082	-0.0169	2.4600	-0.0660	-1.1746	0.0543	-0.4544	0.4906	2.5978	-1.2298		
N*	-0.0019	-0.0158	0.4514	0.0299	0.0051	-0.5511	0.0802	0.1003	0.0297	1.6787		

TABLE III-4 CONTINUED
 BO-105C STABILITY AND CONTROL DERIVATIVES -- US UNITS
 (BODY-FIXED FRL AXIS SYSTEM)

CASE 48		0 KT		LEVEL FLIGHT AT SEA LEVEL			4620 LB		AFT CG	
	PHI	THETA	PSI	ALPHA	BETA	GAMMA	ΘMR	B1S	A1S	ΘTR
	-2.04	3.47	0.00	3.47	-0.18	0.00	14.33	0.24	-0.46	10.34
		XDOT	ZDOT	U0	V0	W0		VT0		
		0.00	0.00	0.00	0.00	0.00		0.00		
	U	W	Q	V	P	R	DC	DB	DA	DP
X	-0.0174	0.0189	1.5755	0.0011	-0.6013	-0.1382	0.5760	0.7910	-0.0244	-0.1205
Z	0.0187	-0.3301	0.1071	-0.0072	-0.2121	1.5952	-9.9770	0.0400	-0.3091	-0.0021
H	0.0201	0.0034	-3.3788	-0.0039	-0.8400	0.0439	0.0721	-0.9751	0.1630	0.0581
Y	-0.0001	-0.0019	-0.5375	-0.0319	-1.5007	0.1740	-0.0731	0.0256	0.8033	-1.6414
L*	-0.0106	-0.0008	2.3000	-0.0632	-9.0283	-0.3233	-0.1433	0.4542	2.6376	-1.0151
N*	-0.0011	0.0000	-0.2183	0.0093	-0.3382	-0.3098	0.5631	-0.0018	0.0482	1.3606

CASE 49		100 KT		LEVEL FLIGHT AT SEA LEVEL			4620 LB		AFT CG	
	PHI	THETA	PSI	ALPHA	BETA	GAMMA	ΘMR	B1S	A1S	ΘTR
	-3.27	-1.99	0.11	-1.99	0.01	0.00	13.69	4.29	-0.13	5.26
		XDOT	ZDOT	U0	V0	W0		VT0		
		168.78	0.00	168.68	0.02	-5.87		168.78		
	U	W	Q	V	P	R	DC	DB	DA	DP
X	-0.0526	0.0365	1.8573	0.0016	-0.4960	-0.1276	0.0795	0.6890	-0.0650	-0.0895
Z	0.0127	-0.9421	0.2341	0.0061	-2.2848	1.6502	-13.9060	3.3737	0.5673	0.0776
H	0.0165	0.0384	-3.6141	-0.0017	-1.0170	0.0356	1.2423	-1.1524	0.1363	0.0869
Y	0.0102	-0.0076	-0.4596	-0.1262	-2.0719	0.5586	-0.2472	0.0837	0.8128	-1.9619
L*	-0.0082	-0.0171	2.4600	-0.0800	-9.0975	-0.1213	-0.5015	0.4743	2.6446	-1.2261
N*	-0.0045	-0.0025	0.1533	0.0257	-0.0931	-0.6449	0.3568	0.0527	0.0397	1.6284

CASE 50		0 KT		LEVEL FLIGHT AT SEA LEVEL			4620 LB		FWD CG	
	PHI	THETA	PSI	ALPHA	BETA	GAMMA	ΘMR	B1S	A1S	ΘTR
	-3.01	2.02	0.00	2.02	-0.11	0.00	14.32	-0.90	-0.23	10.07
		XDOT	ZDOT	U0	V0	W0		VT0		
		0.00	0.00	0.00	0.00	0.00		0.00		
	U	W	Q	V	P	R	DC	DB	DA	DP
X	-0.0164	0.0107	1.6142	0.0002	-0.7252	-0.1960	0.3440	0.8094	-0.0151	-0.1201
Z	0.0016	-0.3352	-0.0478	-0.0011	-0.1256	1.3947	-9.8652	0.0444	0.0213	0.0020
H	0.0199	-0.0058	-1.3795	-0.0041	-0.8400	0.0823	-0.1925	-0.9766	0.1566	0.0562
Y	-0.0019	-0.0041	-0.6752	-0.0329	-1.6504	0.2882	-0.0376	0.0176	0.7850	-1.6357
L*	-0.0117	-0.0048	2.3070	-0.0634	-9.0992	-0.0568	-0.1235	0.4459	2.5805	-1.0113
N*	-0.0006	0.0021	0.1402	0.0102	-0.0298	-0.3175	0.5670	0.0091	0.0369	1.4130

TABLE III-4 CONTINUED
 BO-105C STABILITY AND CONTROL DERIVATIVES -- US UNITS
 (BODY-FIXED FRL AXIS SYSTEM)

CASE	100 KT		LEVEL FLIGHT AT SEA LEVEL				4620 LB	FWD CG		
	PHI	THETA	PSI	ALPHA	BETA	GAMMA	ΘMR	B1S	A1S	ΘTR
	-3.27	-3.43	0.19	-3.43	0.01	0.00	13.81	3.23	0.06	5.01
	XDOT		ZDOT	U0	V0	W0	VTO			
	168.73		0.00	168.48	0.02	-10.11	168.78			
	U	W	Q	V	P	R	DC	DB	DA	DP
X	-0.0525	0.3193	1.8448	0.0012	-0.5890	-0.0773	-0.2482	0.7714	-0.0476	-0.0949
Z	-0.0039	-0.9443	-0.4025	0.0117	-2.0480	1.7349	-13.9082	3.3566	0.5756	0.0770
M	0.0189	0.0160	-3.6019	-0.0017	-1.0170	0.0390	0.8410	-1.0554	0.1522	0.0884
Y	0.0101	-0.0070	-0.4290	-0.1266	-2.0247	0.6098	-0.2250	0.1056	0.8318	-1.9631
L*	-0.0082	-0.0182	2.4600	-0.0800	-8.9286	0.0667	-0.4917	0.4862	2.6572	-1.2270
N*	-0.0057	-0.0055	0.3356	0.0301	-0.0034	-0.6769	0.3798	0.0313	-0.0008	1.6980

CASE	0 KT		LEVEL FLIGHT AT SEA LEVEL				5070 LB	MID CG		
	PHI	THETA	PSI	ALPHA	BETA	GAMMA	ΘMR	B1S	A1S	ΘTR
	-2.97	2.59	0.00	2.59	-0.13	0.00	14.86	-0.46	-0.36	11.06
	XDOT		ZDOT	U0	V0	W0	VTO			
	0.00		0.00	0.00	0.00	0.00	0.00			
	U	W	Q	V	P	R	DC	DB	DA	DP
X	-0.0177	0.3140	1.5483	0.0000	-0.7404	-0.1050	0.3898	0.7901	-0.0073	-0.1118
Z	0.0074	-0.3069	0.0197	-0.0035	-0.2561	1.3638	-9.1554	0.0162	-0.0225	-0.0101
M	0.0211	-0.0013	-3.2978	-0.0036	-0.8400	0.0644	-0.0761	-0.9537	0.1598	0.0601
Y	-0.0027	-0.0016	-0.6385	-0.0338	-1.6899	0.2532	-0.0768	0.0224	0.7896	-1.5213
L*	-0.0121	-0.0007	2.3000	-0.0656	-8.7289	-0.1240	-0.1532	0.4261	2.5145	-0.9665
N*	0.0006	0.0021	0.0498	0.0117	-0.0403	-0.3804	0.6341	0.0054	0.0434	1.3924

CASE	100 KT		LEVEL FLIGHT AT SEA LEVEL				5070 LB	MID CG		
	PHI	THETA	PSI	ALPHA	BETA	GAMMA	ΘMR	B1S	A1S	ΘTR
	-3.02	-2.31	0.12	-2.31	0.00	0.00	14.08	3.93	-0.03	5.37
	XDOT		ZDOT	U0	V0	W0	VTO			
	168.78		0.00	168.64	0.01	-6.80	168.78			
	U	W	Q	V	P	R	DC	DB	DA	DP
X	-0.0501	0.3205	1.9489	0.0017	-0.5108	-0.0822	-0.1785	0.7474	-0.0634	-0.0811
Z	0.0006	-0.8570	-0.0743	0.0089	-2.0359	1.5798	-12.6234	3.0624	0.5294	0.0622
M	0.0188	0.0249	-3.5477	-0.0018	-1.0170	0.0358	1.0051	-1.0798	0.1411	0.0878
Y	0.0086	-0.0091	-0.4318	-0.1174	-2.1079	0.5546	-0.2455	0.0930	0.8077	-1.7872
L*	-0.0093	-0.0170	2.4600	-0.0793	-8.5851	0.1137	-0.4941	0.4471	2.5149	-1.1493
N*	-0.0054	-0.0054	0.3062	0.0278	-0.0309	-0.6549	0.3740	0.0577	0.0201	1.6181

TABLE III-4 CONCLUDED
 BO-105C STABILITY AND CONTROL DERIVATIVES -- US UNITS
 (BODY-FIXED FRL AXIS SYSTEM)

CASE	0 KT		LEVEL FLIGHT AT SEA LEVEL				4000 LB	MID CG		
	PHI	THETA	PSI	ALPHA	BETA	GAMMA	ΘMR	B1S	A1S	ΘTR
	-2.95	2.67	0.00	2.67	-0.14	0.00	13.51	-0.37	-0.28	9.15
	XDOT		ZDOT	U0	V0	W0	VTO			
	0.00		0.00	0.00	0.00	0.00	0.00			
	U	W	Q	V	P	R	DC	DB	DA	DP
X	-0.0170	0.0148	1.5665	0.0002	-0.7534	-0.1048	0.5241	0.9020	-0.0148	-0.1353
Z	0.0113	-0.3769	0.1070	-0.0045	-0.1766	1.2575	-11.0749	0.0580	0.0086	0.0028
H	0.0189	-0.0018	-3.4952	-0.0040	-1.0170	0.0613	-0.0836	-1.0036	0.1752	0.0520
Y	-0.0031	-0.0047	-0.7233	-0.0356	-1.7597	0.2989	-0.0585	0.0048	0.8067	-1.8397
L*	-0.0120	-0.0037	2.4600	-0.0632	-9.9053	-0.1824	-0.1278	0.4910	2.8463	-1.0857
M*	0.0013	0.0024	0.0403	0.0111	-0.9569	-0.3445	0.5162	0.0084	0.0479	1.3951

CASE	100 KT		LEVEL FLIGHT AT SEA LEVEL				4000 LB	MID CG		
	PHI	THETA	PSI	ALPHA	BETA	GAMMA	ΘMR	B1S	A1S	ΘTR
	-3.69	-3.77	0.24	-3.78	0.00	0.00	13.44	3.41	-0.01	4.94
	XDOT		ZDOT	U0	V0	W0	VTO			
	168.78		0.00	168.41	0.01	-11.13	168.78			
	U	W	Q	V	P	R	DC	DB	DA	DP
X	-0.0581	0.0358	1.7086	0.0007	-0.6108	-0.0862	0.0056	0.7251	-0.0439	-0.1102
Z	0.0107	-1.0924	-0.3111	0.0111	-2.4683	1.8197	-16.1164	3.8714	0.6498	0.0750
H	0.0175	0.0274	-3.7048	-0.0015	-1.0170	0.0433	1.0220	-1.1274	0.1503	0.0902
Y	0.0099	-0.0075	-0.4313	-0.1438	-2.2103	0.9638	-0.2435	0.0846	0.8471	-2.2741
L*	-0.0110	-0.0205	-2.4600	-0.0828	-9.7571	0.1412	-0.5232	0.5176	2.8690	-1.3548
M*	-0.0036	-0.0003	0.1656	0.0300	0.1494	-0.8804	0.4028	0.0228	0.0187	1.7271

TABLE III-5
BO-105C TRANSFER FUNCTION FACTORS

CASE 27 -20KT

DENOMINATOR: (0) (.347) (.957) (3.96) (9.03) [-.510; .367] [-.0616; .470] <.353>

CONTROL NUMERATORS:

PHI/DA 2.57 (0) (.347) (-.423) (1.05) (3.77) [-.0829; .478] <-.343>
THE/DB -.981 (0) (0) (.458) (.946) (9.74) [-.515; .350] <-.507>
PSI/DP 1.27 (.348) (3.98) (9.05) [-.0590; .428] [-.0712; .459] <.615>

PHI/DB .462 (0) (.368) (-1.89) [-.478; .801] [.905; 1.10] <-.247>
THE/DA .164 (0) (.00545) (.288) (-.488) (-3.41) [.901; .750] <.000242>

PHI/DA ; THE/DB -2.60 (0) (0) (-.425) (.457) (1.04) <.524>
PHI/DA ; PSI/DP 3.31 (-.0354) (.347) (3.78) [-.0665; .456] <-.0320>
THE/DB ; PSI/DP -1.25 (0) (.454) (9.81) [-.0644; .429] <-1.03>

PHI/DB ; PSI/DP .637 (-.0241) (.683) (-1.59) [.0295; .410] <.00281>
PHI/DP ; THE/DB .817 (0) (0) (.450) [-.0262; 1.71] <1.08>
PHI/DC ; THE/DB .129 (0) (0) (.484) [-.238; 2.81] <.492>

THE/DA ; PSI/DP .203 (-.00386) (.369) (-3.93) [.187; .607] <.000420>
THE/DP ; PHI/DA .368 (0) (-.00355) (.352) (-.383) (2.50) <.000441>
THE/DC ; PHI/DA -.639 (0) (.0105) (-.0687) (-.473) (.853) <-.000186>

PSI/DA ; THE/DB -.0627 (0) (.456) (5.68) [-.191; 1.71] <-.475>
PSI/DB ; PHI/DA .122 (-.0338) (.439) (2.04) [-.516; 1.93] <-.0138>
XD/DB ; PHI/DA 2.08 (0) (-.425) (.462) (1.04) [.0971; 6.32] <-17.0>

YD/DA ; THE/DB -83.6 (0) (-.403) (.457) (1.04) <16.0>
ZD/DB ; PHI/DA -1.23 (0) (1.07) [-.983; .441] [.261; 5.80] <-8.57>
XD/DC ; PHI/DA .286 (0) (-.0707) (-.461) (.853) [-.0224; 8.53] <.578>

YD/DP ; THE/DB 1.47 (0) (.453) [-.372; 1.43] [.956; 5.05] <34.7>
ZD/DC ; PHI/DA -23.9 (0) (-.403) (.997) (3.61) [-.0987; .424] <6.25>

PHI/DA ; THE/DB ; PSI/DP -3.36 (0) (-.0353) (.455) <.0540>
PHI/DC ; THE/DB ; PSI/DP -.241 (0) (-.126) (.709) <.0216>
THE/DC ; PHI/DA ; PSI/DP -1.01 (.0954) [-.918; .0173] <-.288E-4>

PSI/DC ; PHI/DA ; THE/DB -1.30 (0) (-.0238) (.463) <.0143>
XD/DB ; PHI/DA ; PSI/DP 2.70 (-.0353) (.460) [.0967; 6.32] <-1.75>
YD/DA ; THE/DB ; PSI/DP -108. (0) (.454) <-49.0>

ZD/DC ; PHI/DA ; THE/DB 23.9 (0) (0) (-.406) (.949) <-9.20>
ZD/DC ; PHI/DA ; PSI/DP -30.8 (-.0351) (3.60) [-.0112; .389] <.590>
XD/DC ; PHI/DA ; THE/DB .228 (0) (-.0586) (-.794) (.851) <.00902>

XD/DC ; PHI/DA ; PSI/DP .550 (-.0198) (.0795) [.0159; 7.71] <-.0515>
YD/DP ; PHI/DA ; THE/DB 3.25 (0) (.495) (1.04) [-1.09] <-1.82>
ZD/DB ; PHI/DA ; PSI/DP -1.58 (-.0355) (-.419) [.274; 5.80] <-.791>

ZD/DC ; PHI/DA ; THE/DB ; PSI/DP 30.8 (0) (-.0339) <-1.04>
XD/DC ; PHI/DA ; THE/DB ; PSI/DP .265 (-.0274) (-.215) <.00156>

TABLE III-5 CONTINUED
BO-105C TRANSFER FUNCTION FACTORS

CASE 29 HOVER

DENOMINATOR: (0) (.280) (.349) (3.80) (8.93) [-.0541; .417] [.0344; .464] <.124>
YD HD PD R P PL

CONTROL NUMERATORS:

PHI/DA 2.65 (0) (.00378) (.268) (.391) (3.59) [-.0391; .427] <.000688>
 THE/DB - .972 (0) (.284) (.352) (9.68) [.0147; .454] <-.194>
 PSI/DP 1.39 (.330) (3.80) (8.95) [-.0507; .429] [-.00939; .443] <.565>

PHI/DB .461 (0) (-.0121) (.257) (.397) (-1.51) [.208; .330] <.940E-4>
 PHI/DP - .949 (0) (-.0693) (.0720) (.217) (3.42) [-.0725; .404] <.000573>
 PHI/DC - .101 (0) (-.0520) (.261) (-1.41) (4.93) [-.00189; .420] <-.00169>

THE/DA .161 (0) (.00824) (.310) (-.620) (-4.52) [.684; .715] <.000591>
 THE/DP 2.17 (0) (.00647) (.310) (1.74) [-.0128; .437] <.00144>
 THE/DC - .0511 (0) (.0103) (.302) (-3.27) (7.90) [-.0255; .475] <.000931>

PSI/DA .0258 (.329) (3.39) (7.16) [-.0558; .433] [-.124; 2.29] <.203>
 PSI/DB .0460 (.333) (-.496) (-.820) (2.56) (8.59) [.0927; .418] <-.0238>
 PSI/DC .569 (.322) (3.79) (8.94) [-.0703; .430] [-.00791; .463] <.246>

XD/DB .790 (0) (.284) (.353) (8.97) [.0145; .454] [.0990; 6.53] <6.24>
 YD/DA 86.6 (0) (.272) (.377) (3.53) [-.0402; .427] <5.72>
 ZD/DC -9.88 (0) (.186) (3.80) (8.94) [-.0475; .419] [.0350; .466] <-2.38>

XD/DC -.159 (0) (.300) (8.77) [-.0262; .475] [-.981; 5.54] <-2.89>
 YD/DP -1.64 (0) (.0907) (.225) (2.33) [-.0716; .406] [.890; 5.29] <-.359>
 ZD/DB -2.71 (0) (.514) [.102; .450] [-.458; .841] <-.199>

PHI/DA ; THE/DB -2.65 (0) (0) (.00341) (.270) (.392) <-.000954>
 PHI/DA ; PSI/DP 3.70 (.00264) (.333) (3.60) [-.0530; .433] <.00219>
 THE/DB ; PSI/DP -1.36 (0) (.330) (9.72) [-.00950; .439] <-.840>

PHI/DB ; PSI/DP .684 (-.0150) (.318) (-1.35) [.285; .349] <.000538>
 PHI/DP ; THE/DB .862 (0) (.00126) (-.0446) [.997; .161] <-.125E-5>
 PHI/DC ; THE/DB .122 (0) (-.0581) (.262) (-1.40) <.00261>

THE/DA ; PSI/DP .221 (-.00817) (.305) (-4.90) [.196; .350] <.000331>
 THE/DP ; PHI/DA .497 (0) (.00233) (.00691) (.311) (2.13) <.527E-5>
 THE/DC ; PHI/DA -.119 (0) (.00698) (.0172) (.285) (-3.24) <.132E-4>

PSI/DA ; THE/DB -.0325 (0) (.329) (4.97) [-.194; 2.39] <-.303>
 PSI/DB ; PHI/DA .110 (.0127) (.363) (-.390) (.482) (3.00) <-.000286>
 PSI/DC ; THE/DB -.551 (0) (.320) (9.70) [-.0262; .464] <-.368>

PSI/DC ; PHI/DA 1.51 (.0138) (.297) (3.59) [-.0547; .430] <.00411>
 XD/DB ; PHI/DA 2.09 (0) (.00403) (.270) (.392) [-.116; 6.38] <.0363>
 XD/DB ; PSI/DP 1.10 (.330) (8.99) [-.00959; .439] [.0968; 6.54] <27.0>

YD/DA ; THE/DB -85.1 (0) (0) (.274) (.378) <-8.80>
 YD/DA ; PSI/DP 121. (.332) (3.54) [-.0532; .433] <26.6>
 ZD/DC ; PHI/DA -26.1 (0) (0) (.221) (3.60) [-.0349; .428] <-3.81>

ZD/DC ; THE/DB 9.59 (0) (0) (.198) (9.68) [.0173; .458] <3.85>
 ZD/DC ; PSI/DP -13.8 (3.81) (8.94) [-.0528; .429] [-.00874; .446] <-17.2>
 XD/DC ; PHI/DA -.539 (0) (.0133) (.284) [-.897; 4.80] <-.0471>

XD/DC ; THE/DB .0480 (0) (.270) (-2.03) (6.30) [-.0166; .527] <-.0460>
 XD/DC ; PSI/DP 6.00 (.102) (9.08) [.0165; .438] <1.07>
 YD/DP ; PHI/DA -3.57 (0) (.0565) (.207) (3.66) [.0593; .431] <-.0284>

YD/DP ; THE/DB 1.58 (0) (.00296) (2.99) (5.62) [.954; .191] <.00287>
 ZD/DB ; PHI/DA -.770 (0) (.00723) (.410) [-.402; .868] <-.00172>
 ZD/DB ; PSI/DP -5.06 [-.180; .413] [.256; .580] <-.290>

PHI/DA ; THE/DB ; PSI/DP -3.72 (0) (.00250) (.332) <-.00309>
 PHI/DB ; THE/DB ; PSI/DP -3.18 (0) (-.0547) (.758) <.0132>
 THE/DC ; PHI/DA ; PSI/DP -.449 (.00720) (-.0274) (.118) <.105E-4>

TABLE III-5 CONTINUED
B0-105C TRANSFER FUNCTION FACTORS

CASE 29 HOVER

CONTROL NUMERATORS CONCLUDED:

PSI/DC ; PHI/DA ; THE/DB -1.50 (0) (.0138) (.296) <-.00615>
 XD/DB ; PHI/DA ; PSI/DP 2.94 (.00261) (.332) [-.116; 6.38] <.104>
 YD/DA ; THE/DB ; PSI/DP -120. (0) (.331) <-39.6>
 ZD/DC ; PHI/DA ; THE/DB 26.1 (0) (.229) [-.301; .00242] <.349E-4>
 ZD/DC ; THE/DB ; PSI/DP 13.4 (0) (9.72) [-.0112; .442] <25.5>
 ZD/DC ; PHI/DA ; PSI/DP -36.6 (.00363) (3.60) [-.0527; .433] <-.0898>
 XD/DC ; PHI/DA ; THE/DB .116 (0) (.0111) (.266) (-1.91) <-.000653>
 XD/DC ; PHI/DA ; PSI/DP .150 (.0271) (.0595) [-.0313; 9.95] <.0239>
 XD/DC ; THE/DB ; PSI/DP 1.00 (-.328) [-.244; .446] <-.0654>
 YD/DP ; PHI/DA ; THE/DB 3.62 (0) (.00131) (.0684) (.214) <.695E-4>
 ZD/DB ; PHI/DA ; PSI/DP -1.42 (0) [-.0608; .605] <-.519>
 ZD/DC ; PHI/DA ; THE/DB ; PSI/DP 36.8 (0) (.00352) <.130>
 XD/DC ; PHI/DA ; THE/DB ; PSI/DP .207 (.00536) (-.446) <-.000494>

GUST NUMERATORS:

PHI/UG -.0116 (0) (0) (0) (.206) (-.610) [-.918; .294] <-.000126>
 THE/UG -.0200 (0) (0) (.278) (.347) (9.77) [-.0189; .452] <-.00386>
 PSI/UG .00174 (0) (0) (.331) (3.19) (8.71) [-.157; .424] <.00287>
 PHI/VG .0633 (0) (0) (.292) (.317) (3.61) [-.0431; .427] <.00386>
 THE/VG .00358 (0) (0) (0) (.0186) (.309) (1.21) (-7.24) <-.000179>
 PSI/VG -.0102 (0) (0) (.329) (3.82) (9.07) [-.0535; .434] <-.0219>
 PHI/WG .00819 (0) (0) (-.103) (.286) (4.36) [-.0264; .426] <-.000190>
 THE/WG .00330 (0) (0) (-.0299) (.262) (7.20) [-.0727; .528] <.521E-4>
 PSI/WG -.00154 (0) (.151) (-.252) (3.74) (9.03) [-.0322; .435] <.000374>
 PHI/PG 9.25 (0) (.0104) (.268) (.392) (3.66) [-.0376; .427] <.00675>
 THE/PG .833 (0) (.0186) (.309) [-.834; .980] [-.602; 1.12] <.00577>
 PSI/PG .0475 (-.329) (3.33) (6.24) [-.0535; .433] [-.313; 3.41] <.710>
 PHI/QG -2.29 (0) (.234) (.570) [-.763; .258] [-.541; .447] <-.00405>
 THE/QG 3.39 (0) (.00675) (.285) (.355) (9.85) [-.0221; .451] <.00465>
 PSI/QG -.0377 (.331) (-1.48) (7.84) [-.142; .406] [-.173; 1.97] <.0924>
 PHI/RG -.758 (0) (0) (-.0972) (.242) [-.0268; .423] <.00319>
 THE/RG -.242 (0) (0) (.00721) (.311) (9.03) [-.00143; .470] <-.00108>
 PSI/RG .330 (.327) (3.76) (8.93) [-.0892; .408] [-.0267; .453] <.124>
 XD/UG .0163 (0) (.278) (.346) (8.98) [-.0187; .452] [-.0916; 6.56] <.124>
 ZD/UG .0446 (0) (0) (0) [-.113; .475] [-.867; 1.45] <.0210>
 YD/VG .0332 (0) (.286) (.330) (3.52) [-.0440; .426] [-.363; 7.88] <.124>
 XD/WG .00208 (0) (0) (.265) (-4.81) (7.73) (9.73) [-.0733; .530] <-.0559>
 ZD/WG .331 (0) (.292) (3.80) (8.94) [-.0556; .418] [-.0323; .465] <.124>
 PHI/UG ; THE/DB -.00203 (0) (0) (-.0123) (.252) (.466) <.292E-5>
 PHI/UG ; PSI/DP .0177 (0) (0) (.198) (.353) (-.473) <-.000585>
 THE/UG ; PHI/DA -.0548 (0) (0) (.00378) (.266) (.388) <-.214E-4>
 THE/UG ; PSI/DP -.0280 (0) (.330) (9.83) [-.00891; .439] <-.0175>
 PSI/UG ; PHI/DA .00429 (0) (0) (.0466) (.336) (3.29) <.000221>
 PSI/UG ; THE/DB -.000767 (0) (.332) (9.50) [-.00214; .553] <-.000741>
 PHI/VG ; THE/DB -.0632 (0) (0) (0) (.298) (.321) <-.00603>
 PHI/VG ; PSI/DP .0783 (0) (.329) (3.64) [-.0519; .433] <.0176>
 THE/VG ; PHI/DA -.000752 (0) (0) (.00824) (.309) (9.59) <-.184E-4>
 THE/VG ; PSI/DP .00630 (0) (0) (.146) (.428) (-1.42) <-.000561>
 PSI/VG ; PHI/DA -.0286 (0) (.329) (3.59) [-.0528; .431] <-.00630>
 PSI/VG ; THE/DB .0987 (0) (0) (-.00141) (.329) <-.458E-4>

TABLE III-5 CONTINUED
BO-105C TRANSFER FUNCTION FACTORS

CASE 29 HOVER

GUST NUMERATORS CONTINUED:

PHI/WG ; THE/DB	- .00948 (0) (0) (0) (-.108) (.292) <.000299>
PHI/WG ; PSI/DP	.00992 (0) (-.103) (4.53) [-.0331; .433] <-.000867>
THE/WG ; PHI/DA	.00742 (0) (0) (.00676) [-.759; .154] <.119E-5>
THE/WG ; PSI/DP	.00479 (0) (-.0320) (7.54) [-.0207; .448] <.000233>
PSI/WG ; PHI/DA	-.00428 (0) (-.124) (3.56) [-.0194; .407] <.000313>
PSI/WG ; THE/DB	.0136 (0) (-.0344) (-.111) (-.191) <.990E-5>
PHI/PG ; THE/DB	-9.37 (0) (0) (.0100) (.270) (.392) <-.00996>
PHI/PG ; PSI/DP	12.9 (.00930) (.333) (3.66) [-.0512; .433] <.0274>
THE/PG ; PHI/DA	.710 (0) (0) (.0418) (.273) (.397) <.00322>
THE/PG ; PSI/DP	1.15 (.168) [.914; .470] [-.615; .649] <.0180>
PSI/PG ; PHI/DA	-.113 (.309) (.458) (3.44) [-.137; .359] <-.00707>
PSI/PG ; THE/DB	-.0845 (0) (.329) (4.10) [-.370; 3.04] <-1.05>
PHI/QG ; THE/DB	.658 (0) (0) (-.101) [.996; .303] <.00612>
PHI/QG ; PSI/DP	-3.21 (.293) [-.879; .334] [-.604; .424] <-.0188>
THE/QG ; PHI/DA	9.35 (0) (-.272) (-.397) [-.962; .00668] <.450E-4>
THE/QG ; PSI/DP	4.72 (.00677) (.330) (9.87) [-.00846; .439] <.0201>
PSI/QG ; PHI/DA	-.0408 (.0459) (.337) (-2.60) [-.398; 2.08] <.00712>
PSI/QG ; THE/DB	-1.20 (-.0575) (.327) [-.322; .196] <.000868>
PHI/RG ; THE/DB	.177 (0) (0) (0) (-.117) (.237) <-.00492>
PHI/RG ; PSI/DP	.219 (-.0432) [-.766; .440] [.497; .560] <-.000573>
THE/RG ; PHI/DA	-.629 (0) (0) (.313) [-.997; .0104] <-.212E-4>
THE/RG ; PSI/DP	-.379 (.00646) (.313) (9.78) [-.00823; .439] <-.00144>
PSI/RG ; PHI/DA	.874 (.00390) (.321) (3.58) [-.0483; .419] <.000688>
PSI/RG ; THE/DB	-.309 (0) (.327) (9.72) [-.0169; .445] <-.194>
XD/UG ; PHI/DA	.0431 (0) (.00378) (.266) (.387) [-.115; 6.39] <.000688>
XD/UG ; THE/DB	.00275 (0) (.242) (-.266) [-.600; .437] <-.337E-4>
XD/UG ; PSI/DP	.0228 (.330) (8.99) [-.00899; .439] [.0873; 6.57] <.565>
ZD/UG ; PHI/DA	.0123 (0) (.0302) [-.0195; .00127] [.815; 1.59] <.152E-8>
ZD/UG ; THE/DB	-.00420 (0) (0) (.689) (9.81) [-.0560; .466] <-.00618>
ZD/UG ; PSI/DP	.0608 (0) (0) (1.77) [-.183; .448] <.0216>
YD/VG ; PHI/DA	.0372 (0) (.147) (-.192) (3.56) [.0234; .429] <.000688>
YD/VG ; THE/DB	-.0324 (0) (0) (.290) (.334) [-.387; 7.85] <-.194>
YD/VG ; PSI/DP	.0294 (.329) (3.59) [-.0520; .433] [.232; 9.32] <.565>
XD/WG ; PHI/DA	.0561 (0) (0) (-4.20) [.840; .127] <-.00382>
XD/WG ; THE/DB	-.00463 (0) (0) (.290) (6.79) [-.0113; .535] <-.00260>
XD/WG ; PSI/DP	.00271 (0) (-5.22) (8.20) (9.99) [-.0211; .449] <-.233>
ZD/WG ; PHI/DA	.876 (0) (.00375) (.318) (3.60) [-.0391; .428] <.000688>
ZD/WG ; THE/DB	-.322 (0) (0) (-.299) (9.69) [-.0113; .456] <-.194>
ZD/WG ; PSI/DP	.460 (3.81) (8.96) [-.0518; .429] [-.0108; .443] <.565>
XD/UG ; ZD/DC	-.161 (0) (.184) (8.98) [-.0218; .456] [.0917; 6.57] <-2.38>
YD/VG ; ZD/DC	-.318 (0) (.182) (3.51) [-.0389; .426] [.353; 8.01] <-2.38>
PHI/UG ; THE/DB ; PSI/DP	-.00352 (0) (-.0152) (.313) <.167E-4>
THE/UG ; PHI/DA ; PSI/DP	-.0775 (0) (-.00264) (.333) <-.682E-4>
PSI/UG ; PHI/DA ; THE/DB	-.00202 (0) (.0128) (.344) <-.888E-5>
PHI/VG ; THE/DB ; PSI/DP	-.0795 (0) (0) (.329) <-.0261>
THE/VG ; PHI/DA ; PSI/DP	.00433 (0) (-.00823) (.289) <-.103E-4>
PSI/VG ; PHI/DA ; THE/DB	.0287 (0) (0) (.329) <.00943>
PHI/WG ; THE/DB ; PSI/DP	-.0120 (0) (0) (-.108) <.00130>
THE/WG ; PHI/DA ; PSI/DP	.0112 (0) (-.00597) (.0211) <.141E-5>
PSI/WG ; PHI/DA ; THE/DB	.00397 (0) (0) (-.114) <-.000454>

TABLE III-5 CONTINUED
BO-105C TRANSFER FUNCTION FACTORS

CASE 29 HOVER

GUST NUMERATORS CONCLUDED:

PHI/PG ; THE/DB ; PSI/DP	-13.2 (0) (.00864) (.332) <-.0378>
THE/PG ; PHI/DA ; PSI/DP	1.01 (.00205) (.0773) (.335) <.537E-4>
PSI/PG ; PHI/DA ; THE/DB	.0836 (0) (.298) (.455) <.0113>
PHI/QG ; THE/DB ; PSI/DP	.812 (0) (.102) (.323) <.0267>
THE/QG ; PHI/DA ; PSI/DP	13.1 (.00397) (.00515) (.332) <.890E-4>
PSI/QG ; PHI/DA ; THE/DB	-.347 (-.00143) (.0749) (.326) <.121E-4>
PHI/RG ; THE/DB ; PSI/DP	-.0270 (.00122) (-.0287) (1.32) <.125E-5>
THE/RG ; PHI/DA ; PSI/DP	-1.04 (.00231) (.00698) (.314) <-.527E-5>
PSI/RG ; PHI/DA ; THE/DB	-.848 (0) (.00355) (.321) <-.000965>
XD/UG ; PHI/DA ; THE/DB	.000242 (0) (.0425) (.238) (-.258) <-.635E-6>
XD/UG ; PHI/DA ; PSI/DP	.0609 (.00264) (.333) [.114; 6.40] <.00219>
XD/UG ; THE/DB ; PSI/DP	.00483 (.395) [-.0687; .255] <.000124>
ZD/UG ; PHI/DA ; THE/DB	-.0116 (0) (0) (.00723) (.640) <-.535E-4>
ZD/UG ; PHI/DA ; PSI/DP	.0170 (0) (0) (-.0514) (1.67) <-.00146>
ZD/UG ; THE/DB ; PSI/DP	-.00581 (0) (9.88) [-.0139; .396] <-.00901>
YD/VG ; PHI/DA ; THE/DB	-.0372 (0) (0) (.148) (.204) <-.00112>
YD/VG ; PHI/DA ; PSI/DP	.0133 (.244) (3.25) [-.0650; .455] <.00219>
YD/VG ; THE/DB ; PSI/DP	-.0293 (0) (.329) [.249; 9.33] <-.840>
XD/WG ; PHI/DA ; THE/DB	-.0114 (0) (0) (.0185) (.282) <-.596E-4>
XD/WG ; PHI/DA ; PSI/DP	.0776 (0) (-.00291) (-4.63) <.00105>
XD/WG ; THE/DB ; PSI/DP	-.00645 (0) (7.08) [-.00628; .495] <-.0112>
ZD/WG ; PHI/DA ; THE/DB	-.876 (0) (0) (.00338) (.321) <-.000950>
ZD/WG ; PHI/DA ; PSI/DP	1.23 (.00265) (3.60) [-.0528; .433] <.00219>
ZD/WG ; THE/DB ; PSI/DP	-.449 (0) (9.73) [-.0122; .438] <-.840>
XD/UG ; ZD/DC ; PHI/DA	-.426 (0) (0) (.219) [.115; 6.40] <-3.81>
XD/UG ; ZD/DC ; THE/DB	-.0281 (0) (-.386) [.407; .444] <.00214>
XD/UG ; ZD/DC ; PSI/DP	-.226 (8.99) [-.0108; .441] [.0870; 6.58] <-17.2>
YD/VG ; ZD/DC ; PHI/DA	-.342 (0) (.00896) (3.57) [-.0157; .433] <-.00205>
YD/VG ; ZD/DC ; THE/DB	.311 (0) (0) (.195) [.377; 7.98] <3.85>
YD/VG ; ZD/DC ; PSI/DP	-.294 (3.58) [-.0520; .433] [.233; 9.33] <-17.2>
XD/UG ; PHI/DA ; THE/DB ; PSI/DP	.000400 (0) (.508) <.000203>
ZD/UG ; PHI/DA ; THE/DB ; PSI/DP	-.0161 (0) (0) <-.0161>
YD/VG ; PHI/DA ; THE/DB ; PSI/DP	-.0132 (0) (.245) <-.00322>
XD/WG ; PHI/DA ; THE/DB ; PSI/DP	-.0162 (0) (.00412) <-.667E-4>
ZD/WG ; PHI/DA ; THE/DB ; PSI/DP	-1.23 (0) (.00250) <-.00309>
XD/UG ; ZD/DC ; PHI/DA ; THE/DB	-.00290 (0) (.0186) (-.646) <.349E-4>
YD/VG ; ZD/DC ; PHI/DA ; THE/DB	.343 (0) (.00872) (.0117) <.349E-4>
YD/VG ; ZD/DC ; PHI/DA ; PSI/DP	-.133 (3.32) [-.0593; .450] <-.0898>
XD/WG ; ZD/DC ; PHI/DA ; THE/DB	.0746 (0) (.0110) (.796) <.000653>
XD/UG ; ZD/DC ; PHI/DA ; THE/DB ; PSI/DP	-.00486 (.00169) <-.821E-5>
YD/VG ; ZD/DC ; PHI/DA ; THE/DB ; PSI/DP	.132 (0) <.132>
XD/WG ; ZD/DC ; PHI/DA ; THE/DB ; PSI/DP	.0918 (.00538) <.000494>

TABLE III-5 CONTINUED
BO-105C TRANSFER FUNCTION FACTORS

CASE 3I 20KT

DENOMINATOR: (0) (.0268) (.447) (3.89) (8.86) [-.0560; .439] [.135; .919] <.0671>

CONTROL NUMERATORS:

PHI/DA	2.59	(0)	(.450)	(3.67)	[-.103; .423]	[.203; .787]	<.472>
THE/DB	-.971	(0)	(.0181)	(.0481)	(.458)	(9.68)	[-.115; .914] <-.00313>
PSI/DP	1.28	(.449)	(3.92)	(8.97)	[-.0406; .436]	[.0288; .441]	<.743>
PHI/DB	.486	(0)	(.416)	(-1.52)	[-.353; 1.02]	[.659; 1.04]	<-.349>
PHI/DP	-.890	(0)	(.451)	(-1.68)	(1.81)	(3.35)	[-.0468; .437] <.780>
PHI/DC	-.151	(0)	(.475)	(-2.99)	[-.0464; .445]	[.910; 2.88]	<.351>
THE/DA	.165	(0)	(.0210)	(.467)	(-5.47)	(-4.69)	[.505; .872] <.00315>
THE/DP	2.02	(0)	(.0200)	(.465)	(1.74)	[-.0867; .395]	<.00534>
THE/DC	1.08	(0)	(.0205)	[.111; .398]	[.963; .796]	<.00221>	
PSI/DA	-.247	(.451)	(1.58)	(-2.67)	(4.82)	[-.0598; .444]	<.447>
PSI/DB	.0354	(.427)	(-4.35)	(7.49)	[.0741; .432]	[-.00621; 1.90]	<-.333>
PSI/DC	.469	(.464)	(3.94)	(8.92)	[-.0370; .440]	[.0394; .476]	<.335>
XD/DB	.800	(0)	(.0614)	(.463)	(9.01)	[.114; .913]	[.0836; 6.46] <7.12>
YD/DA	84.6	(.447)	(3.61)	[-.112; .426]	[.173; .781]	<15.1>	
ZD/DC	-9.37	(0)	(-.0279)	(3.84)	(8.86)	[-.0477; .429]	[.131; .947] <1.47>
XD/DC	-.0978	(0)	(9.13)	[.0907; .402]	[.971; .846]	[.0457; 6.29]	<-4.08>
YD/DP	-1.51	(.447)	(-1.45)	[-.0470; .437]	[.883; 2.23]	[.887; 5.19]	<25.1>
ZD/DB	.490	(0)	(.0772)	(-.435)	(8.82)	[.127; .908]	[.298; 5.87] <-4.14>
PHI/DA ; THE/DB	-2.59	(0)	(.00802)	(.460)	[.181; .770]	<-.00567>	
PHI/DA ; PSI/DP	3.33	(.0351)	(.450)	(3.69)	[-.0472; .440]	<.0374>	
THE/DB ; PSI/DP	-1.25	(.00770)	(.460)	(9.81)	[.0326; .437]	<-.00825>	
PHI/DB ; PSI/DP	.653	(.0102)	(.251)	(-1.48)	[.513; .406]	<-.000409>	
PHI/DP ; THE/DB	.804	(0)	(.00770)	(.461)	(-1.68)	(1.80)	<-.00865>
PHI/DC ; THE/DB	.0965	(0)	(.00992)	(.494)	(3.14)	(-3.30)	<-.00490>
THE/DA ; PSI/DP	.208	(.0172)	(.469)	(-4.58)	[.198; .292]	<-.000656>	
THE/DP ; PHI/DA	.461	(0)	(.0177)	(.148)	(.463)	(1.71)	<.000957>
THE/DC ; PHI/DA	.289	(0)	(-.0198)	(.238)	[.830; .828]	<-.000933>	
PSI/DA ; THE/DB	.287	(.00794)	(.461)	(1.85)	(-2.70)	<-.00525>	
PSI/DB ; PHI/DA	.0816	(.0362)	(.439)	(-4.25)	[.0844; 1.73]	<-.0165>	
PSI/DC ; THE/DB	-.459	(.00995)	(.482)	(9.72)	[.0411; .469]	<-.00470>	
PSI/DC ; PHI/DA	1.22	(.0516)	(.458)	(3.72)	[-.0401; .448]	<.0215>	
XD/DB ; PHI/DA	2.09	(0)	(.464)	[.181; .769]	[.0999; 6.30]	<22.8>	
YD/DB ; PSI/DP	1.03	(.464)	(9.11)	[.0325; .437]	[.0836; 6.47]	<34.6>	
YD/DA ; THE/DB	-83.1	(.00792)	(.459)	[.144; .766]	<-.177>		
YD/DA ; PSI/DP	108.	(.448)	(3.64)	[-.0479; .439]	<34.2>		
ZD/DC ; PHI/DA	-24.2	(0)	(3.63)	[-.117; .379]	[.169; .821]	<-8.50>	
ZD/DC ; THE/DB	9.04	(0)	(9.67)	[.661; .0306]	[.0861; .906]	<.0672>	
ZD/DC ; PSI/DP	-12.0	(3.90)	(8.97)	[.0192; .432]	[-.0217; .475]	<-14.8>	
XD/DC ; PHI/DA	-.259	(0)	(.182)	[.818; .863]	[.121; 5.96]	<-1.25>	
XD/DC ; THE/DB	.0133	(0)	(-.0591)	(.783)	(4.06)	[-.439; 4.19]	<-.0437>
XD/DC ; PSI/DP	-.0741	(.164)	(8.47)	[-.0159; .453]	[.475; 5.39]	<-.614>	
YD/DP ; PHI/DA	-3.18	(.466)	(-1.08)	(1.08)	(3.75)	[-.0168; .441]	<1.26>
YD/DP ; THE/DB	1.45	(.00770)	(.459)	(-1.47)	(5.86)	[.837; 2.51]	<-.278>
ZD/DB ; PHI/DA	1.24	(0)	(-.429)	[.202; .764]	[.319; 5.77]	<-10.3>	
ZD/DB ; PSI/DP	.624	(-.397)	(8.90)	[.0317; .437]	[.294; 5.94]	<-14.9>	
PHI/DA ; THE/DB ; PSI/DP	-3.35	(.00770)	(.0351)	(.460)	<-.000416>		
PHI/DC ; THE/DB ; PSI/DP	-.256	(.00767)	(-.0738)	(.576)	<.835E-4>		
THE/DC ; PHI/DA ; PSI/DP	.155	(.0330)	(-.0805)	(.286)	<-.000117>		

TABLE III-5 CONTINUED
BO-105C TRANSFER FUNCTION FACTORS

CASE 31 20KT

CONTROL NUMERATORS CONCLUDED:

PSI/DC ; PHI/DA ; THE/DB -1.23 (.00933) (.0532) (.476) <- .000290>

XD/DB ; PHI/DA ; PSI/DP 2.69 (.0350) (.464) [.0999; 6.31] <1.74>

YD/DA ; THE/DB ; PSI/DP -107. (.00772) (.459) <- .381>

ZD/DC ; PHI/DA ; THE/DB 24.1 (0) (.00596) [.135; .753] <.0816>

ZD/DC ; THE/DB ; PSI/DP 11.7 (.00549) (9.83) [.0323; .438] <.121>

ZD/DC ; PHI/DA ; PSI/DP -31.3 (.0363) (3.66) [-.0353; .429] <- .764>

XD/DC ; PHI/DA ; THE/DB .0262 (0) (1.88) [-.358; 1.10] <.0600>

XD/DC ; PHI/DA ; PSI/DP - .184 (.0157) (.208) [.258; 5.44] <- .0178>

XD/DC ; THE/DB ; PSI/DP .498 (1.41) [-.0456; .394] <.109>

YD/DP ; PHI/DA ; THE/DB 3.21 (.00770) (.464) (1.09) (-1.12) <- .0140>

ZD/DB ; PHI/DA ; PSI/DP 1.58 (.0350) (-.399) [.314; 5.82] <- .749>

ZD/DC ; PHI/DA ; THE/DB ; PSI/DP 31.4 (.00545) (.0359) <.00613>

XD/DC ; PHI/DA ; THE/DB ; PSI/DP .0598 (.0369) (2.57) <.00567>

GUST NUMERATORS:

PHI/UG .00578 (0) (0) (0) (.455) (1.16) [-.836; 3.35] <.0343>

THE/UG -.0200 (0) (0) (.0268) (.448) (9.51) [-.0504; .957] <- .00209>

PSI/UG .0128 (0) (0) (.451) (3.44) (8.70) [-.0900; .435] <.0328>

PHI/VG -.0676 (0) (0) (.114) (.437) (3.65) [.0719; .413] <.00209>

THE/VG -.0410 (0) (0) (-.00638) (.0225) (.471) (1.12) <.310E-5>

PSI/VG -.0166 (0) (0) (.449) (3.98) (9.46) [-.0528; .445] <- .0558>

PHI/WG -.00466 (0) (0) (-1.27) (1.82) [-.0358; .349] <.00131>

THE/WG -.00104 (0) (0) (9.20) [.880; .0343] [-.0978; .976] <- .107E-4>

PSI/WG .00174 (0) (3.71) (8.83) [.395; .369] [-.0184; .415] <.00134>

PHI/PG 9.21 (0) (.449) (3.74) [-.115; .435] [.213; .806] <1.90>

THE/PG .882 (0) (.0215) (.471) [-.785; 1.01] [-.491; 1.28] <.0149>

PSI/PG .196 (.450) (2.44) (5.10) [-.0530; .445] [-.411; 2.87] <1.80>

PHI/QG -2.34 (0) (.405) (-.755) [-.774; 1.06] [-.206; 1.15] <1.06>

THE/QG 3.43 (0) (.0194) (.0479) (.459) (9.84) [.114; .916] <.0121>

PSI/QG -.246 (.421) (-1.64) (7.64) [-.0901; .431] [-.327; 2.05] <1.01>

PHI/RG .0719 (0) (.488) (1.49) [-.0274; .297] [-.610; 3.91] <.0705>

THE/RG -.217 (0) (-.00502) (.0222) (.467) (9.55) [-.00862; .994] <.000104>

PSI/RG .235 (.470) (3.62) (8.76) [-.0907; .310] [-.113; .447] <.0671>

XD/UG .0224 (0) (.0267) (.449) (8.97) [.0400; .954] [.187; 5.53] <.0671>

ZD/UG .214 (0) (0) (.0241) (.586) (3.32) (8.86) [.120; .890] <.0704>

YD/VG .0732 (0) (.114) (.446) (3.34) [-.0706; .410] [.673; 5.67] <.0671>

XD/WG -.00316 (0) (0) (-.0270) (-1.49) (6.41) (8.79) [-.0603; 1.03] <- .00755>

ZD/WG .462 (0) (.0267) (3.88) (8.86) [-.0515; .434] [-.135; .917] <.0671>

PHI/UG ; THE/DB .00409 (0) (0) (.432) (-2.40) (2.55) <- .0108>

PHI/UG ; PSI/DP .0188 (0) (-.0173) (-.548) [.986; .439] <.343E-4>

THE/UG ; PHI/DA - .0526 (0) (0) (.451) [-.0941; .787] <- .0147>

THE/UG ; PSI/DP - .0271 (0) (.450) (9.96) [.0330; .436] <- .0231>

PSI/UG ; PHI/DA - .0331 (0) (-.00654) (.0664) (.451) (3.19) <- .206E-4>

PSI/UG ; THE/DB - .0117 (0) (.440) (9.75) [.0409; .453] <- .0103>

PHI/VG ; THE/DB - .0669 (0) (0) (.0121) (.223) (.451) <- .813E-4>

PHI/VG ; PSI/DP .0716 (0) (.449) (3.72) [-.0460; .440] <.0231>

THE/VG ; PHI/DA - .00419 (0) (0) (.0151) (.470) (2.56) <- .761E-4>

THE/VG ; PSI/DP .00546 (0) (-.0396) (.168) (.448) (-2.11) <.343E-4>

PSI/VG ; PHI/DA - .0445 (0) (.451) (3.67) [-.0454; .434] <- .0139>

PSI/VG ; THE/DB .170 (0) (.460) [-.144; .0140] <.154E-4>

TABLE III-5 CONTINUED
BO-105C TRANSFER FUNCTION FACTORS

CASE 31 20KT

GUST NUMERATORS CONTINUED:

PHI/WG ; THE/DB	.000754	(0)	(0)	(.0372)	(-1.30)	(3.22)	<-.000117>		
PHI/WG ; PSI/DP	.00122	(0)	(1.83)	(-2.62)	[-.0396;	.423]	<-.00105>		
THE/WG ; PHI/DA	-.00265	(0)	(0)	(.0860)	[-.0780;	.775]	<-.000137>		
THE/WG ; PSI/DP	-.0156	(0)	(.0769)	(.0155;	.433]	<-.000226>			
PSI/WG ; PHI/DA	.00451	(0)	(.333)	(3.47)	[-.0971;	.366]	<.000698>		
PSI/WG ; THE/DB	-.00165	(0)	(.0368)	(9.76)	[-.281;	.442]	<-.000116>		
PHI/PG ; THE/DB	-9.37	(0)	(.00417)	(.460)	[-.184;	.792]	<-.0113>		
PHI/PG ; PSI/DP	11.9	(.0406)	(.449)	(3.76)	[-.0446;	.440]	<.159>		
THE/PG ; PHI/DA	.763	(0)	(.0816)	(.463)	[-.247;	.736]	<.0156>		
THE/PG ; PSI/DP	1.10	(.140)	(.430)	(.667)	[-.521;	.705]	<.0220>		
PSI/PG ; PHI/DA	.319	(-.0211)	(.446)	(4.25)	[-.196;	.616]	<-.00485>		
PSI/PG ; THE/DB	-.222	(.00401)	(.461)	(2.96)	[-.431;	2.89]	<-.0101>		
PHI/QG ; THE/DB	.603	(0)	(.0461)	(.473)	[-.169;	1.01]	<.0135>		
PHI/QG ; PSI/DP	-3.21	(.138)	[-.656;	.425]	[-.818;	.595]	<-.0284>		
THE/QG ; PHI/DA	9.26	(0)	(.0140)	(.461)	[-.176;	.771]	<.0354>		
THE/QG ; PSI/DP	4.41	(.0139)	(.460)	(9.99)	[-.0338;	.436]	<.0535>		
PSI/QG ; PHI/DA	-.587	(.0442)	(.436)	(-1.70)	[-.414;	1.88]	<.0679>		
PSI/QG ; THE/DB	.117	(.0461)	(.473)	(8.59)	[-.0357;	.763]	<.0128>		
PHI/RG ; THE/DB	.0355	(0)	(.0119)	(.472)	(3.53)	(-3.91)	<-.00274>		
PHI/RG ; PSI/DP	.301	(.0129)	(.668)	(1.02)	[-.300;	.426]	<.000479>		
THE/RG ; PHI/DA	-.572	(0)	(.0151)	(.467)	[-.0335;	.799]	<-.00257>		
THE/RG ; PSI/DP	-3.12	(.0151)	(.467)	[-.0346;	.435]	<-.00418>			
PSI/RG ; PHI/DA	.606	(.0421)	(.462)	(3.38)	[-.00387;	.279]	<.00309>		
PSI/RG ; THE/DB	-.220	(.0119)	(.468)	(9.71)	[-.0310;	.470]	<-.00261>		
XD/UG ; PHI/DA	.0583	(0)	(.451)	[-.0930;	.783]	[-.185;	5.41]	<.472>	
XD/UG ; THE/DB	-.0613	(0)	(.160)	(.753)	[-.0920;	.650]	<-.00313>		
XD/UG ; PSI/DP	.0301	(.450)	(9.11)	[-.0328;	.436]	[-.151;	5.63]	<.743>	
ZD/UG ; PHI/DA	.554	(0)	(0)	(.542)	(3.10)	[-.205;	.729]	<.495>	
ZD/UG ; THE/DB	-.198	(0)	(0)	(.0811)	(9.70)	[-.150;	.920]	<-.132>	
ZD/UG ; PSI/DP	.273	(0)	(.505)	(3.32)	(8.96)	[-.0328;	.436]	<.780>	
YD/VG ; PHI/DA	.135	(0)	(.104)	(.347)	(3.68)	[-.142;	.416]	<.00309>	
YD/VG ; THE/DB	-.0713	(0)	(.0121)	(.225)	(.456)	[-.717;	5.44]	<-.00261>	
YD/VG ; PSI/DP	.0686	(.449)	(3.54)	[-.0466;	.439]	[-.603;	5.94]	<.743>	
XD/WG ; PHI/DA	-.00819	(0)	(0)	(-1.49)	(6.09)	[-.0419;	.818]	<.0496>	
XD/WG ; THE/DB	.00390	(0)	(0)	(.0436)	(9.49)	[-.0759;	.961]	<.00149>	
XD/WG ; PSI/DP	-.00386	(0)	(-2.10)	(7.25)	(8.60)	[-.0152;	.433]	<.0949>	
ZD/WG ; PHI/DA	1.20	(0)	(3.65)	[-.0985;	.420]	[-.205;	.784]	<.472>	
ZD/WG ; THE/DB	-.448	(0)	(.0180)	(.0481)	(9.68)	[-.117;	.914]	<-.00313>	
ZD/WG ; PSI/DP	.591	(3.90)	(8.97)	[-.0403;	.431]	[-.0313;	.440]	<.743>	
XD/UG ; ZD/DC	-.189	(0)	(-.0307)	(8.95)	[-.0750;	.970]	[-.208;	5.48]	<1.47>
YD/VG ; ZD/DC	-.679	(0)	(-.0841)	(3.31)	[-.211;	.490]	[-.671;	5.70]	<1.47>
PHI/UG ; THE/DB ; PSI/DP	-.00447	(0)	(.0100)	(.291)	<-.131E-4>				
THE/UG ; PHI/DA ; PSI/DP	-.0735	(0)	(.0351)	(.451)	<-.00116>				
PSI/UG ; PHI/DA ; THE/DB	-.0314	(0)	(.0364)	(.448)	<-.000513>				
PHI/VG ; THE/DB ; PSI/DP	-.0725	(0)	(.00770)	(.460)	<-.000256>				
THE/VG ; PHI/DA ; PSI/DP	.00254	(0)	(.0181)	(.480)	<.221E-4>				
PSI/VG ; PHI/DA ; THE/DB	.0447	(0)	(.00797)	(.461)	<.000164>				
PHI/WG ; THE/DB ; PSI/DP	-.000402	(0)	(.00768)	(-3.72)	<.115E-4>				
THE/WG ; PHI/DA ; PSI/DP	-.00422	(0)	(.0312)	(.0933)	<-.123E-4>				
PSI/WG ; PHI/DA ; THE/DB	-.00443	(0)	(.0109)	(.272)	<-.132E-4>				

TABLE III-5 CONTINUED
BO-105C TRANSFER FUNCTION FACTORS

CASE 31 20KT

GUST NUMERATORS CONCLUDED:

PHI/PQ ; THE/DB ; PSI/DP	-12.2	(.00768)	(.0405)	(.460)	<-.00175>
THE/PQ ; PHI/DA ; PSI/DP	.924	(.0342)	(.0853)	(.463)	<.00125>
PSI/PQ ; PHI/DA ; THE/DB	-.344	(.0204)	(-.188)	(.458)	<.000603>
PHI/QG ; THE/DB ; PSI/DP	.871	(.00777)	(.108)	(.472)	<.000345>
THE/QG ; PHI/DA ; PSI/DP	12.0	(.0138)	(.0349)	(.461)	<.00267>
PSI/QG ; PHI/DA ; THE/DB	.296	(.474)	[.178 ; .0549]	<.000423>	
PHI/RG ; THE/DB ; PSI/DP	-.137	(.00841)	(.0132)	(.503)	<-.761E-5>
THE/RG ; PHI/DA ; PSI/DP	-.844	(.0151)	(.0352)	(.467)	<-.000210>
PSI/RG ; PHI/DA ; THE/DB	-.588	(.0119)	(.0389)	(.466)	<-.000127>
XD/UG ; PHI/DA ; THE/DB	-.0159	(0)	(.607)	[.266 ; .767]	<-.00567>
XD/UG ; PHI/DA ; PSI/DP	.0789	(.0351)	(.451)	[.172 ; 5.47]	<.0374>
XD/UG ; THE/DB ; PSI/DP	-.00753	(.614)	(9.01)	[.0418 ; .445]	<-.00825>
ZD/UG ; PHI/DA ; THE/DB	-.529	(0)	(0)	[.234 ; .786]	<-.327>
ZD/UG ; PHI/DA ; PSI/DP	.709	(0)	(.0353)	(.507)	(3.10) <.0393>
ZD/UG ; THE/DB ; PSI/DP	-.253	(0)	(9.80)	[.0326 ; .436]	<-.471>
YD/VG ; PHI/DA ; THE/DB	-.136	(0)	(.0122)	(.186)	(.411) <-.000127>
YD/VG ; PHI/DA ; PSI/DP	.119	(.437)	(3.67)	[-.0478 ; .443]	<.0374>
YD/VG ; THE/DB ; PSI/DP	-.0675	(.00770)	(.460)	[.635 ; 5.88]	<-.00825>
XD/WG ; PHI/DA ; THE/DB	.0103	(0)	(0)	[.163 ; .763]	<.00603>
XD/WG ; PHI/DA ; PSI/DP	-.00998	(0)	(.0483)	(-2.10)	(6.49) <.00657>
XD/WG ; THE/DB ; PSI/DP	.00499	(0)	(9.96)	[.000840 ; .436]	<.00945>
ZD/WG ; PHI/DA ; THE/DB	-1.20	(0)	(.00799)	[.185 ; .770]	<-.00567>
ZD/WG ; PHI/DA ; PSI/DP	1.54	(.0352)	(3.67)	[-.0438 ; .434]	<.0374>
ZD/WG ; THE/DB ; PSI/DP	-.575	(.00767)	(9.81)	[.0322 ; .437]	<-.00825>
XD/UG ; ZD/DC ; PHI/DA	-.490	(0)	[-.0606 ; .776]	[.196 ; 5.37]	<-8.50>
XD/UG ; ZD/DC ; THE/DB	.569	(0)	(.723)	[-.257 ; .404]	<.0672>
XD/UG ; ZD/DC ; PSI/DP	-.267	(9.14)	[.0341 ; .437]	[.135 ; 5.65]	<-14.8>
YD/VG ; ZD/DC ; PHI/DA	-1.25	(0)	(-.103)	(3.63)	[.207 ; .498] <.116>
YD/VG ; ZD/DC ; THE/DB	.657	(0)	(.0171)	(.138)	[.716 ; 5.48] <.0464>
YD/VG ; ZD/DC ; PSI/DP	-.646	(3.52)	[-.0359 ; .429]	[.602 ; 5.95]	<-14.8>
XD/UG ; PHI/DA ; THE/DB ; PSI/DP	-.0198	(.0350)	(.599)	<-.000416>	
ZD/UG ; PHI/DA ; THE/DB ; PSI/DP	-.678	(0)	(.0350)	<-.0237>	
YD/VG ; PHI/DA ; THE/DB ; PSI/DP	-.120	(.00770)	(.451)	<-.000416>	
XD/WG ; PHI/DA ; THE/DB ; PSI/DP	.0135	(0)	(.0371)	<.000499>	
ZD/WG ; PHI/DA ; THE/DB ; PSI/DP	-1.54	(.00767)	(.0351)	<-.000416>	
XD/UG ; ZD/DC ; PHI/DA ; THE/DB	.142	(0)	[.310 ; .757]	<.0816>	
YD/VG ; ZD/DC ; PHI/DA ; THE/DB	1.25	(0)	(.0253)	(.0753)	<.00238>
YD/VG ; ZD/DC ; PHI/DA ; PSI/DP	-1.12	(3.64)	[-.0408 ; .433]	<-.764>	
XD/WG ; ZD/DC ; PHI/DA ; THE/DB	-.108	(0)	[-.125 ; .744]	<-.0600>	
XD/UG ; ZD/DC ; PHI/DA ; THE/DB ; PSI/DP	.174	(.0353)	<.00613>		
YD/VG ; ZD/DC ; PHI/DA ; THE/DB ; PSI/DP	1.12	(.00546)	<.00613>		
XD/WG ; ZD/DC ; PHI/DA ; THE/DB ; PSI/DP	-.154	(.0369)	<-.00567>		

TABLE III-5 CONTINUED
BO-105C TRANSFER FUNCTION FACTORS

CASE 32 40KT

DENOMINATOR: (0) (.0363) (.506) (4.13) (9.13) [-.125; .478] [.152; 1.34] <.281>

CONTROL NUMERATORS:

PHI/DA	2.61	(0)	(.516)	(3.90)	[-.128; .472]	[.168; 1.30]	<1.98>
THE/DB	-.971	(0)	(.0167)	(.0383)	(.645)	(9.97)	[.139; 1.32] <-.00694>
PSI/DP	1.34	(.518)	(4.17)	(9.01)	[.0319; .413]	[-.108; .477]	<1.01>
PHI/DB	.484	(0)	(.296)	(-.793)	[-.602; 1.28]	[.624; 1.48]	<-.409>
THE/DA	.179	(0)	(.0301)	(-.460)	(.683)	(-3.45)	[.244; 1.26] <.00933>
PHI/DA ; THE/DB	-2.62	(0)	(.0126)	(.648)	[.159; 1.28]	<-.0353>	
PHI/DA ; PSI/DP	3.53	(.0348)	(.519)	(3.92)	[-.115; .476]	<.0566>	
THE/DB ; PSI/DP	-1.30	(.0130)	(.646)	(9.91)	[.0374; .414]	<-.0186>	
PHI/DB ; PSI/DP	.687	(.123)	(.171)	(-1.18)	[.366; .598]	<-.00608>	
PHI/DP ; THE/DB	.863	(0)	(.0130)	(.646)	(-2.22)	(2.42)	<-.0390>
PHI/DC ; THE/DB	.0667	(0)	(.0143)	(.899)	(4.46)	(-4.81)	<-.0183>
THE/DA ; PSI/DP	.236	(-.169)	(.702)	(-4.35)	[.723; .162]	<.00323>	
THE/DP ; PHI/DA	.446	(0)	(-.0914)	(.124)	(.618)	(2.00)	<-.00626>
THE/DC ; PHI/DA	.738	(0)	(-.0264)	(.241)	[.310; 1.26]	<-.00745>	
PSI/DA ; THE/DB	-.648	(.0126)	(.653)	[.0300; 1.77]	<-.0167>		
PSI/DB ; PHI/DA	.0936	(.0212)	(.315)	(-.476)	[.282; 4.20]	<-.00525>	
XD/DB ; PHI/DA	2.04	(0)	(.671)	[.159; 1.28]	[.0664; 6.34]	<90.8>	
YD/DA ; THE/DB	-84.5	(.0126)	(.647)	[.149; 1.28]	<-1.13>		
ZD/DB ; PHI/DA	2.78	(0)	(-.0770)	[.167; 1.28]	[.298; 6.46]	<-14.7>	
XD/DC ; PHI/DA	-.338	(0)	(.190)	[.309; 1.27]	[-.00839; 8.47]	<-7.38>	
YD/DP ; THE/DB	1.51	(.0130)	(.646)	(-1.93)	(5.88)	[.773; 2.95]	<-1.26>
ZD/DC ; PHI/DA	-26.5	(0)	(3.57)	[.0566; .401]	[.157; 1.34]	<-27.4>	
PHI/DA ; THE/DB ; PSI/DP	-3.56	(.0127)	(.0350)	(.647)	<-.00103>		
PHI/DC ; THE/DB ; PSI/DP	-.211	(.0113)	(-.0434)	(.995)	<.000103>		
THE/DC ; PHI/DA ; PSI/DP	.845	(-.0168)	(.0314)	(.256)	<-.000114>		
PSI/DC ; PHI/DA ; THE/DB	-.916	(.0129)	(.0562)	(.865)	<-.000575>		
XD/DB ; PHI/DA ; PSI/DP	2.77	(.0348)	(.669)	[.0663; 6.34]	<2.59>		
YD/DA ; THE/DB ; PSI/DP	-114.	(.0129)	(.646)	<-.954>			
ZD/DC ; PHI/DA ; THE/DB	25.8	(0)	(.0104)	[.143; 1.27]	<.433>		
ZD/DC ; PHI/DA ; PSI/DP	-35.9	(.0356)	(3.61)	[.0706; .425]	<-.835>		
XD/DC ; PHI/DA ; THE/DB	-.237	(0)	(-1.14)	[.293; 1.33]	<.472>		
XD/DC ; PHI/DA ; PSI/DP	-.344	(.0353)	(.211)	[-.0330; 9.00]	<-.207>		
YD/DP ; PHI/DA ; THE/DB	3.41	(.0128)	(.642)	(1.57)	(-1.58)	<-.0692>	
ZD/DB ; PHI/DA ; PSI/DP	3.74	(.0351)	(-.0747)	[.296; 6.48]	<-.412>		
ZD/DC ; PHI/DA ; THE/DB ; PSI/DP	35.4	(.0115)	(.0352)	<.0143>			
XD/DC ; PHI/DA ; THE/DB ; PSI/DP	-.316	(.0297)	(-.959)	<.00898>			

TABLE III-5 CONTINUED

BO-105C TRANSFER FUNCTION FACTORS

CASE 33 60KT

DENOMINATOR: (0) (.0478) (.511) (4.54) (8.93) [-.195; .456] [.208; 1.69] <.588>
S SP R P D

CONTROL NUMERATORS:

PHI/DA	2.62	(0)	(.525)	(4.22)	[-.192; .449]	[.230; 1.65]	<3.17>
THE/DB	- .994	(0)	(.0255)	(.0505)	(.758)	(9.86)	[-.202; 1.67] <-.0265>
PSI/DP	1.47	(.525)	(4.62)	(8.84)	[-.0330; .407]	[-.170; .456]	<1.09>
PHI/DB	.487	(0)	(.313)	(-.556)	[-.559; 1.57]	[.547; 2.04]	<-.868>
PHI/DP	-1.07	(0)	(.530)	(-2.46)	[-.179; .451]	[.997; 3.48]	<3.42>
PHI/DC	- .303	(0)	(.547)	(-3.71)	[-.232; .530]	[.652; 3.09]	<1.65>
THE/DA	.174	(0)	(.0384)	(-.241)	(.811)	(-4.71)	[-.281; 1.57] <.0153>
THE/DP	2.19	(0)	(.0376)	(.774)	(2.46)	[-.994; .295]	<.0136>
THE/DC	.527	(.0324)	(.0803)	(.394)	(9.90)	[.280; 1.58]	<.0134>
PSI/DA	.375	(.537)	(2.46)	[-.205; .454]	[-.110; 3.12]	<.995>	
PSI/DB	.0738	(.323)	(-.428)	(9.56)	[.108; .460]	[-.0147; 3.64]	<-.274>
PSI/DC	.287	(.544)	(5.93)	(8.59)	[-.0598; .458]	[-.276; .561]	<.524>
XD/DB	.722	(0)	(.0551)	(.850)	(9.26)	[.201; 1.66]	[.0452; 6.52] <36.6>
YD/DA	85.4	(.519)	(4.21)	[-.195; .448]	[.213; 1.64]	<101. >	
ZD/DC	-11.4	(0)	(.0369)	(3.45)	(8.96)	[.539; .422]	[.219; 1.78] <-7.38>
XD/DC	-17.4	(0)	(.117)	(.359)	(9.58)	[.287; 1.58]	<-17.4>
YD/DP	-1.73	(.524)	(-2.31)	[-.179; .449]	[.813; 3.24]	[.913; 4.99]	<110. >
ZD/DB	1.79	(0)	(.00387)	(.0585)	(9.14)	[-.208; 1.66]	[.260; 6.81] <.474>
PHI/DA ; THE/DB	-2.69	(0)	(.0221)	(.762)	[.227; 1.63]	<-.120>	
PHI/DA ; PSI/DP	3.88	(.0463)	(.528)	(4.26)	[-.182; .452]	<.0822>	
THE/DB ; PSI/DP	-1.47	(.0227)	(.759)	(9.89)	[-.0450; .412]	<-.0426>	
PHI/DB ; PSI/DP	.796	(.134)	(.166)	(-.983)	[.136; .905]	<-.0143>	
PHI/DP ; THE/DB	1.00	(0)	(.0227)	(.760)	(-2.51)	(3.08)	<-.134>
PHI/DC ; THE/DB	.0446	(0)	(.0230)	(1.12)	(6.37)	(-7.44)	<-.0544>
THE/DA ; PSI/DP	.254	(.117)	(.179)	(-.233)	(.826)	(-5.11)	<.00523>
THE/DP ; PHI/DA	.494	(0)	(.0923)	(-.226)	(.722)	(2.07)	<-.0154>
THE/DC ; PHI/DA	1.43	(0)	(.0175)	(.469)	[.280; 1.58]	<.0292>	
PSI/DA ; THE/DB	-.0358	(.0221)	(.770)	(6.73)	[-.127; 3.03]	<-.0376>	
PSI/DB ; PHI/DA	.182	(.0251)	(-.351)	(.355)	[-.00489; 3.68]	<-.00766>	
PSI/DC ; THE/DB	-.324	(.0230)	(1.05)	(9.86)	[.0460; .476]	<-.0174>	
PSI/DC ; PHI/DA	.756	(.0625)	(.543)	(5.27)	[-.272; .535]	<.0387>	
XD/DB ; PHI/DA	1.93	(0)	(.847)	[.226; 1.63]	[.0578; 6.36]	<175. >	
XD/DB ; PSI/DP	1.07	(.844)	(9.23)	[.0461; .412]	[.0442; 6.54]	<60.5>	
YD/DA ; THE/DB	-86.6	(.0221)	(.760)	[-.211; 1.62]	<-3.81>		
YD/DA ; PSI/DP	125.	(.524)	(4.28)	[-.183; .450]	<57.0>		
ZD/DC ; PHI/DA	-29.8	(0)	(3.15)	[.709; .397]	[.231; 1.71]	<-43.4>	
ZD/DC ; THE/DB	10.4	(0)	(.0278)	(.0410)	(9.85)	[.184; 1.66]	<.322>
ZD/DC ; PSI/DP	-16.9	(3.54)	(8.88)	[.733; .411]	[-.0391; .421]	<-15.8>	
XD/DC ; PHI/DA	-45.3	(0)	(.457)	[.276; 1.58]	<-51.7>		
XD/DC ; THE/DB	-.420	(0)	(-.0183)	(-.269)	(9.92)	[.322; 1.56]	<-.0501>
XD/DC ; PSI/DP	2.45	(.465)	(9.38)	(-9.80)	[.0368; .419]	<-18.4>	
YD/DP ; PHI/DA	-3.70	(.542)	(-2.15)	(2.21)	(4.23)	[-.167; .454]	<8.32>
YD/DP ; THE/DB	1.70	(.0227)	(.759)	(-2.38)	(6.02)	[.742; 3.20]	<-4.32>
ZD/DB ; PHI/DA	4.55	(0)	(.00813)	[.233; 1.63]	[.282; 6.75]	<4.47>	
ZD/DB ; PSI/DP	2.62	(.0106)	(9.10)	[-.0442; .412]	[.256; 6.86]	<2.02>	
PHI/DA ; THE/DB ; PSI/DP	-4.01	(.0222)	(.0465)	(.761)	<-.00315>		
PHI/DC ; THE/DB ; PSI/DP	-.261	(-.0160)	(.0221)	(1.36)	<.000125>		
THE/DC ; PHI/DA ; PSI/DP	1.98	(.0220)	(.0450)	(.483)	<.000946>		

TABLE III-5 CONTINUED
BO-105C TRANSFER FUNCTION FACTORS

CASE 33 60KT

CONTROL NUMERATORS CONCLUDED:

PSI/DC ; PHI/DA ; THE/DB -.876 (.0222) (.0696) (1.03) <-.00139>

XD/DB ; PHI/DA ; PSI/DP 2.89 (.0462) (.843) [.0579; 6.36] <4.55>
 YD/DA ; THE/DB ; PSI/DP -129. (.0225) (.759) <-2.21>
 ZD/DC ; PHI/DA ; THE/DB 28.1 (0) (.0219) [.211; 1.61] <1.60>

ZD/DC ; THE/DB ; PSI/DP 15.5 (.0227) (9.93) [.0445; .414] <.597>
 ZD/DC ; PHI/DA ; PSI/DP -44.3 (.0470) (3.21) [.746; .423] <-1.19>
 XD/DC ; PHI/DA ; THE/DB -1.14 (0) (-.120) [.255; 1.59] <.345>

XD/DC ; PHI/DA ; PSI/DP 6.42 (.0468) (.473) (-9.75) <-1.39>
 XD/DC ; THE/DB ; PSI/DP -6.28 (-.0195) (9.51) [-.0510; .425] <.0210>
 YD/DP ; PHI/DA ; THE/DB 3.79 (.0223) (.757) (2.20) (-2.26) <-.319>

ZD/DB ; PHI/DA ; PSI/DP 6.70 (.00888) (.0472) [.281; 6.80] <.130>

ZD/DC ; PHI/DA ; THE/DB ; PSI/DP 42.5 (.0222) (.0471) <.0443>
 XD/DC ; PHI/DA ; THE/DB ; PSI/DP -1.70 (-.0214) (.0242) <.000881>

GUST NUMERATORS:

PHI/UG .0101 (0) (0) (0) [.803; 1.36] [-.228; 2.79] <.145>
 THE/UG -0.178 (0) (0) (.0478) (.736) (9.95) [.182; 1.71] <-.0183>
 PSI/UG .00628 (0) (0) (9.20) [.149; .470] [.912; 1.92] <.0471>

PHI/VG .0689 (0) (0) (4.10) [-.130; .432] [.962; .588] <.0183>
 THE/VG -0.0640 (0) (0) (-.00230) (.0400) [.973; .994] <.581E-5>
 PSI/VG -0.0248 (0) (0) (.519) (4.82) (8.59) [-.199; .460] <-.113>

PHI/WG .00780 (0) (0) (2.08) [-.00786; .327] [-.229; 3.80] <.0250>
 THE/WG -0.124 (0) (0) [.985; .0519] [.144; 1.79] <-.00108>
 PSI/WG .0106 (0) (3.56) (9.07) [.0147; .343] [.186; .453] <.00824>

PHI/PG 9.35 (0) (.517) (4.31) [-.205; .455] [.237; 1.64] <11.6>
 THE/PG .946 (0) (.0396) (.875) [.550; 1.09] [-.175; 1.44] <.0806>
 PSI/PG .387 (.521) (2.71) [-.197; .459] [-.242; 5.61] <3.63>

PHI/QG -2.40 (0) (.260) (-.330) [-.280; 1.62] [.642; 2.00] <2.14>
 THE/QG 36.1 (0) (.0281) (.0497) (.784) [.201; 1.67] <.110>
 PSI/QG -0.315 (.273) (-.330) (9.62) [.149; .454] [.0847; 3.48] <.682>

PHI/RG 5.72 (0) (.586) (3.12) [-.140; .421] <1.85>
 THE/RG -0.142 (0) (-.00225) (.0399) (.856) (9.82) [-.0378; 2.36] <.000597>
 PSI/RG .675 (.574) (4.34) (8.95) [-.138; .402] [.0465; .491] <.588>

XD/UG .0341 (0) (.0476) (.875) (9.15) [.162; 1.71] [.343; 3.94] <.588>
 ZD/UG .0644 (0) (0) (.0476) (9.09) [.177; 1.69] [.408; 4.83] <1.85>
 YD/VG .0920 (0) (3.43) [-.130; .426] [-.982; .616] [.765; 5.19] <.588>

XD/WG -0.0232 (0) (0) (.0368) (-2.40) [.163; 1.79] [.991; 8.48] <.471>
 ZD/WG .787 (0) (.0477) (4.11) (8.94) [-.0179; .393] [.205; 1.66] <.588>

PHI/UG ; THE/DB -.00141 (0) (0) (.705) [-.120; 5.20] <-.0270>
 PHI/UG ; PSI/DP .0216 (0) (-.00228) (-.201) [.638; 1.04] <.108E-4>
 THE/UG ; PHI/DA -0.0483 (0) (0) (.740) [-.211; 1.66] <-.0985>

THE/UG ; PSI/DP -0.273 (0) (.738) [.0468; .410] <-.0338>
 PSI/UG ; PHI/DA .0162 (0) (-.00123) (.141) [.928; 1.87] <-.984E-5>
 PSI/UG ; THE/DB -0.00493 (0) (-.709) (9.84) [.0151; .498] <-.00852>

PHI/VG ; THE/DB -0.0688 (0) (0) (.0231) [.985; .716] <-.000815>
 PHI/VG ; PSI/DP .0750 (0) (-.527) (4.21) [-.182; .451] <.0338>
 THE/VG ; PHI/DA -0.0107 (0) (0) (.0309) [.997; 1.16] <-.000444>

THE/VG ; PSI/DP .00368 (0) (-.00502) (.0849) (.697) (-9.85) <.108E-4>
 PSI/VG ; PHI/DA -0.0665 (0) (.528) (4.28) [-.185; .453] <-.0309>
 PSI/VG ; THE/DB .0247 (0) (0) (.0201) (.764) (9.99) <.00377>

TABLE III-5 CONTINUED
BO-105C TRANSFER FUNCTION FACTORS

CASE 33 60KT

GUST NUMERATORS CONTINUED:

PHI/WG ; THE/DB	-0.0172	(0)	(0)	(.0388)	[-.00835; 6.38]	<-.00271>	
PHI/WG ; PSI/DP	.0228	(0)	(-.320)	(1.68)	[.00489; .359]	<-.00157>	
THE/WG ; PHI/DA	-.0338	(0)	(0)	(.0653)	[.182; 1.71]	<-.00644>	
THE/WG ; PSI/DP	-.204	(0)	(.0646)	(.0400; .406)	<-.00218>		
PSI/WG ; PHI/DA	.0275	(0)	(.204)	(3.42)	[-.0535; .328]	<.00206>	
PSI/WG ; THE/DB	-.00960	(0)	(.0387)	(9.84)	[.132; .488]	<-.000872>	
PHI/PG ; THE/DB	-9.76	(0)	(.0208)	(.761)	[.230; 1.61]	<-.403>	
PHI/PG ; PSI/DP	13.8	(.0493)	(.524)	(4.35)	[-.182; .454]	<.319>	
THE/PG ; PHI/DA	.842	(0)	(.0738)	(.786)	[.212; 1.65]	<.133>	
THE/PG ; PSI/DP	1.39	(.0808)	(.626)	(1.07)	[-.479; .929]	<.0648>	
PSI/PG ; PHI/DA	-.230	(.333)	[-.281; .208]	[.778; 2.27]	<-.0170>		
PSI/PG ; THE/DB	-.0643	(.0208)	(.766)	(5.26)	[-.374; 4.84]	<-.126>	
PHI/QG ; THE/DB	.630	(0)	(.0334)	(.983)	[.183; 1.78]	<.0654>	
PHI/QG ; PSI/DP	-3.87	(-.327)	[.807; .0618]	[.508; 1.08]	<.00568>		
THE/QG ; PHI/DA	9.84	(0)	(.0261)	(.786)	[.226; 1.63]	<.535>	
THE/QG ; PSI/DP	53.7	(.0264)	(.783)	[.0469; .410]	<.187>		
PSI/QG ; PHI/DA	-.768	(.0443)	(-.331)	(.332)	[.101; 3.52]	<.0463>	
PSI/QG ; THE/DB	.0472	(.0334)	(1.46)	(9.16)	[.0578; .985]	<.0204>	
PHI/RG ; THE/DB	-.486	(0)	(.0231)	(.793)	(9.26)	<-.0825>	
PHI/RG ; PSI/DP	.752	(.0336)	(.640)	(3.02)	[-.193; .409]	<.00817>	
THE/RG ; PHI/DA	-.374	(0)	(.0310)	(.865)	[.0338; 2.12]	<-.0450>	
THE/RG ; PSI/DP	-3.42	(.0265)	(.881)	[.0524; .397]	<-.0125>		
PSI/RG ; PHI/DA	1.77	(.0502)	(.569)	(4.07)	[-.123; .424]	<.0370>	
PSI/RG ; THE/DB	-.661	(.0231)	(.787)	(9.86)	[.0360; .470]	<-.0262>	
XD/UG ; PHI/DA	.0901	(0)	(.872)	[.202; 1.66]	[.340; 3.84]	<3.17>	
XD/UG ; THE/DB	-.0211	(0)	(.0617)	(.813)	(9.77)	[.209; 1.60]	<-.0265>
XD/UG ; PSI/DP	.0509	(.871)	(9.14)	[.0481; .409]	[.316; 4.00]	<1.09>	
ZD/UG ; PHI/DA	.166	(0)	(0)	[.210; 1.64]	[.420; 4.74]	<9.97>	
ZD/UG ; THE/DB	-.0322	(0)	(0)	(.0784)	(9.71)	[.285; 1.67]	<-.0686>
ZD/UG ; PSI/DP	.0941	(0)	(9.06)	[.0463; .410]	[.376; 4.89]	<3.42>	
YD/VG ; PHI/DA	.187	(0)	(4.22)	[-.0200; .429]	[.852; .505]	<.0370>	
YD/VG ; THE/DB	-.0915	(0)	(.0231)	[.987; .749]	[.816; 4.70]	<-.0262>	
YD/VG ; PSI/DP	.0925	(.524)	(3.84)	[-.183; .449]	[.711; 5.38]	<1.09>	
XD/WG ; PHI/DA	-.0600	(0)	(0)	(-2.42)	(7.52)	[.202; 1.70]	<3.17>
XD/WG ; THE/DB	.0320	(0)	(0)	(.0474)	(9.94)	[.186; 1.74]	<.0457>
XD/WG ; PSI/DP	-.0330	(0)	(-2.63)	[.0400; .406]	[.983; 8.71]	<1.09>	
ZD/WG ; PHI/DA	2.06	(0)	(3.83)	[-.0224; .390]	[.231; 1.63]	<3.17>	
ZD/WG ; THE/DB	-.761	(0)	(.0254)	(.0504)	(9.85)	[.208; 1.66]	<-.0265>
ZD/WG ; PSI/DP	1.16	(4.15)	(8.87)	[-.0135; .385]	[.0444; .415]	<1.09>	
XD/VG ; ZD/DC	-.392	(0)	(.0446)	(9.14)	[.155; 1.65]	[.356; 4.11]	<-7.38>
YD/VG ; ZD/DC	-1.04	(0)	(.133)	(2.57)	[.650; .871]	[.749; 5.23]	<-7.38>
PHI/UG ; THE/DB ; PSI/DP	-.00706	(0)	(.0913)	(.688)	<-.00044>		
THE/UG ; PHI/DA ; PSI/DP	-.0746	(0)	(.0463)	(.740)	<-.00255>		
PSI/UG ; PHI/DA ; THE/DB	-.0133	(0)	(.0252)	(.713)	<-.000238>		
PHI/VG ; THE/DB ; PSI/DP	-.0770	(0)	(.0227)	(.757)	<-.00132>		
THE/VG ; PHI/DA ; PSI/DP	-.00327	(0)	(.109)	(.454)	<-.000162>		
PSI/VG ; PHI/DA ; THE/DB	.0691	(0)	(.0221)	(.766)	<.00117>		
PHI/WG ; THE/DB ; PSI/DP	-.0122	(0)	(.0166)	(-.163)	<.331E-4>		
THE/WG ; PHI/DA ; PSI/DP	-.0552	(0)	(.0423)	(.0673)	<-.000157>		
PSI/WG ; PHI/DA ; THE/DB	-.0259	(0)	(.0225)	(.161)	<-.936E-4>		

TABLE III-5 CONTINUED
B0-105C TRANSFER FUNCTION FACTORS

CASE 33 60KT

GUST NUMERATORS CONCLUDED:

PHI/PG ; THE/DB ; PSI/DP	-14.5	(.0212)	(.0498)	(.760)	<-.0116>	
THE/PG ; PHI/DA ; PSI/DP	1.29	(.0445)	(.0746)	(.784)	<.00336>	
PSI/PG ; PHI/DA ; THE/DB	.177	(.0228)	(.278)	(.859)	<.000965>	
PHI/QG ; THE/DB ; PSI/DP	.981	(.0268)	(.0972)	(.874)	<.00223>	
THE/QG ; PHI/DA ; PSI/DP	14.7	(.0264)	(.0463)	(.784)	<.0141>	
PSI/QG ; PHI/DA ; THE/DB	.105	(.0212)	(-.112)	(1.85)	<-.000460>	
PHI/RG ; THE/DB ; PSI/DP	-.597	(.0248)	(.0402)	(.815)	<-.000484>	
THE/RG ; PHI/DA ; PSI/DP	-.889	(.0269)	(.0468)	(.883)	<-.000987>	
PSI/RG ; PHI/DA ; THE/DB	-1.79	(.0222)	(.0484)	(.786)	<-.00151>	
XD/UG ; PHI/DA ; THE/DB	-.0569	(0)	(.813)	[.227; 1.61]	<-.120>	
XD/UG ; PHI/DA ; PSI/DP	.136	(.0463)	(.870)	[.328; 3.88]	<.0822>	
XD/UG ; THE/DB ; PSI/DP	-.0313	(.808)	(9.64)	[.0446; .418]	<-.0426>	
ZD/UG ; PHI/DA ; THE/DB	-.0863	(0)	(0)	[.306; 1.66]	<-.239>	
ZD/UG ; PHI/DA ; PSI/DP	.242	(0)	(.0463)	[.397; 4.80]	<.259>	
ZD/UG ; THE/DB ; PSI/DP	-.0462	(0)	(9.49)	[.0482; .404]	<-.0714>	
YD/VG ; PHI/DA ; THE/DB	-.192	(0)	(.0226)	[.994; .590]	<-.00151>	
YD/VG ; PHI/DA ; PSI/DP	.183	(.525)	(4.25)	[-.176; .449]	<.0822>	
YD/VG ; THE/DB ; PSI/DP	-.0934	(.0227)	(.759)	[.748; 5.14]	<-.0426>	
XD/WG ; PHI/DA ; THE/DB	.0865	(0)	(0)	[.224; 1.65]	<.236>	
XD/WG ; PHI/DA ; PSI/DP	-.0851	(0)	(.0449)	(-2.65)	(7.88)	<.0797>
XD/WG ; THE/DB ; PSI/DP	.480	(0)	[.0364; .405]	<.0786>		
ZD/WG ; PHI/DA ; THE/DB	-2.05	(0)	(.0221)	[.233; 1.63]	<-.120>	
ZD/WG ; PHI/DA ; PSI/DP	3.04	(.0463)	(3.85)	[-.0171; .389]	<.0822>	
ZD/WG ; THE/DB ; PSI/DP	-1.12	(.0227)	(9.85)	[.0443; .412]	<-.0426>	
XD/UG ; ZD/DC ; PHI/DA	-1.03	(0)	[.189; 1.62]	[.358; 4.00]	<-43.4>	
XD/UG ; ZD/DC ; THE/DB	.235	(0)	(.0563)	(9.76)	[.201; 1.58]	<.322>
XD/UG ; ZD/DC ; PSI/DP	-.588	(9.14)	[.0470; .414]	[.332; 4.14]	<-15.8>	
YD/VG ; ZD/DC ; PHI/DA	-2.11	(0)	(.111)	(3.16)	[.630; .784]	<-.456>
YD/VG ; ZD/DC ; THE/DB	.948	(0)	(.0232)	(.641)	[.818; 4.75]	<.319>
YD/VG ; ZD/DC ; PSI/DP	-1.05	(2.89)	[.745; .424]	[.701; 5.39]	<-15.8>	
XD/UG ; PHI/DA ; THE/DB ; PSI/DP	-.0851	(.0458)	(.808)	<-.00315>		
ZD/UG ; PHI/DA ; THE/DB ; PSI/DP	-.122	(0)	(.0483)	<-.00588>		
YD/VG ; PHI/DA ; THE/DB ; PSI/DP	-.189	(.0223)	(.746)	<-.00315>		
XD/WG ; PHI/DA ; THE/DB ; PSI/DP	.129	(0)	(.0436)	<.00563>		
ZD/WG ; PHI/DA ; THE/DB ; PSI/DP	-3.06	(.0221)	(.0466)	<-.00315>		
XD/UG ; ZD/DC ; PHI/DA ; THE/DB	.632	(0)	[.218; 1.59]	<1.60>		
YD/VG ; ZD/DC ; PHI/DA ; THE/DB	2.00	(0)	(.0228)	(.387)	<.0176>	
YD/VG ; ZD/DC ; PHI/DA ; PSI/DP	-2.08	(3.21)	[.745; .424]	<-1.19>		
XD/WG ; ZD/DC ; PHI/DA ; THE/DB	-.0360	(0)	[-.126; 3.10]	<-.345>		
XD/UG ; ZD/DC ; PHI/DA ; THE/DB ; PSI/DP	.952	(.0465)	<.0443>			
YD/VG ; ZD/DC ; PHI/DA ; THE/DB ; PSI/DP	1.99	(.0223)	<.0443>			
XD/WG ; ZD/DC ; PHI/DA ; THE/DB ; PSI/DP	-.0735	(.0120)	<-.000881>			

TABLE III-5 CONTINUED
BO-105C TRANSFER FUNCTION FACTORS

CASE 34 80KT

DENOMINATOR: (0) (.0356) (.465) (4.91) (8.70) [-.318; .459] [.131; 2.03] <.616>

CONTROL NUMERATORS:

PHI/DA 2.62 (0) (.474) (4.49) [-.313; .454] [.156; 1.99] <4.53>
 THE/DB -1.04 (0) (.825) (9.70) [.996; .0354] [.134; 2.01] <-.0419>
 PSI/DP 1.60 (.472) (5.02) (8.60) [.0245; .421] [-.295; .459] <1.22>

PHI/DB .481 (0) (.321) (-.536) [-.620; 1.46] [.375; 2.47] <-1.09>
 THE/DA .163 (0) (-.0382) (-.144) (.902) (-6.17) [.197; 1.91] <.0182>

PHI/DA ; THE/DB -2.79 (0) (.0307) (.829) [.158; 1.97] <-.276>
 PHI/DA ; PSI/DP 4.21 (.0598) (.474) (4.54) [-.308; .456] <.113>
 THE/DB ; PSI/DP -1.67 (.0311) (.826) (9.76) [.0378; .426] <-.0757>

PHI/DB ; PSI/DP .885 (-1.22) [.918; .171] [.0490; .932] <-.0273>
 PHI/DP ; THE/DB 1.17 (0) (.0311) (.827) (-2.80) (3.74) <-.316>
 PHI/DC ; THE/DB .0432 (0) (.0308) (1.13) (-8.29) (9.10) <-.114>

THE/DA ; PSI/DP .258 (.102) (.203) (-.221) (.921) (-6.49) <.00706>
 THE/DP ; PHI/DA .560 (0) (.0919) (-.320) (.754) (2.25) <-.0280>
 THE/DC ; PHI/DA 2.10 (0) (.0300) (.568) [.190; 1.92] <.131>

PSI/DA ; THE/DB -0.0394 (.0307) (.837) (5.21) [-.396; 3.52] <-.0652>
 PSI/DB ; PHI/DA .243 (-.00140) (-.180) (.406) [-.299; 3.10] <.000240>
 XD/DB ; PHI/DA 1.76 (0) (1.04) [.157; 1.97] [.0330; 6.36] <289. >

YD/DA ; THE/DB -90.8 (.0307) (.827) [.138; 1.96] <-8.80>
 ZD/DB ; PHI/DA 6.54 (0) (.0406) [.161; 1.98] [.283; 6.89] <49.1>
 XD/DC ; PHI/DA 9.24 (0) (.599) (-6.70) [.182; 1.92] <-137. >

YD/DP ; THE/DB 1.91 (.0311) (.826) (-2.91) (6.04) [.741; 3.44] <-10.2>
 ZD/DC ; PHI/DA -33.1 (0) (.161) [.930; 1.89] [.177; 2.08] <-81.9>

PHI/DA ; THE/DB ; PSI/DP -4.53 (.0304) (.0601) (.828) <-.00686>
 PHI/DC ; THE/DB ; PSI/DP -3.23 (0) (.0325) (1.43) <-.0150>
 THE/DC ; PHI/DA ; PSI/DP 3.22 (.0319) (.0595) (.574) <.00352>

PSI/DC ; PHI/DA ; THE/DB -0.935 (.0306) (.0846) (1.02) <-.00247>
 XD/DB ; PHI/DA ; PSI/DP 2.87 (.0596) (1.04) [.0338; 6.36] <7.18>
 YD/DA ; THE/DB ; PSI/DP -147. (.0309) (.826) <-3.74>

ZD/DC ; PHI/DA ; THE/DB 30.0 (0) (.0307) [.142; 1.97] <3.56>
 ZD/DC ; PHI/DA ; PSI/DP -53.4 (.0603) (.162) [.923; 2.02] <-2.12>
 XD/DC ; PHI/DA ; THE/DB -2.05 (0) (.00731) [.163; 1.93] <-.0556>

XD/DC ; PHI/DA ; PSI/DP 15.5 (.0600) (.606) (-6.13) <-3.47>
 YD/DP ; PHI/DA ; THE/DB 4.19 (.0307) (.823) (2.91) (-3.01) <-.927>
 ZD/DB ; PHI/DA ; PSI/DP 10.4 (.0392) (.0617) [-.285; 6.96] <1.22>

ZD/DC ; PHI/DA ; THE/DB ; PSI/DP 49.5 (.0303) (.0607) <.0910>
 XD/DC ; PHI/DA ; THE/DB ; PSI/DP -3.34 [.876; .0622] <-.0129>

TABLE III-5 CONTINUED
BO-105C TRANSFER FUNCTION FACTORS

CASE 35 100KT

DENOMINATOR: (0) (.0402) (.423) (5.47) (8.45) [-.569; .535] [.138; 2.26] <1.15>

CONTROL NUMERATORS:

PHI/DA 2.65 (0) (.422) (4.90) [-.566; .529] [.173; 2.23] <7.62>
THE/DB -1.09 (0) (.0335) (.0482) (.864) (9.59) [.140; 2.25] <-.0736>
PSI/DP 1.67 (.419) (5.58) (8.30) [-.00479; .452] [-.552; .532] <1.87>

PHI/DB .472 (0) (.448) (-.785) [-.532; 1.43] [.269; 2.49] <-2.10>
THE/DA .146 (0) (.0287) (-.0829) (.964) (-9.38) [.218; 2.17] <.0149>

PHI/DA ; THE/DB -2.96 (0) (.0365) (.867) [.174; 2.22] <-.462>
PHI/DA ; PSI/DP 4.43 (.0747) (.421) (4.94) [-.563; .531] <.194>
THE/DB ; PSI/DP -1.84 (.0372) (.864) (9.61) [.00454; .453] <-.116>

PHI/DB ; PSI/DP .927 (-1.60) [-.690; .183] [.232; .871] <-.0375>
PHI/DP ; THE/DB 1.34 (0) (.0372) (.865) (-3.14) (4.49) <-.607>
PHI/DC ; THE/DB .716 (0) (.0371) (.995) (-8.14) <-.215>

THE/DA ; PSI/DP .243 (.120) (.196) (-.214) (1.01) (-9.53) <.0117>
THE/DP ; PHI/DA .673 (0) (.106) (-.458) (.691) (2.67) <-.0603>
THE/DC ; PHI/DA 2.81 (0) (.0348) (.587) [.204; 2.14] <.263>

PSI/DA ; THE/DB -0.0211 (.0365) (.870) (6.79) [-.818; 4.38] <-.0871>
PSI/DB ; PHI/DA .284 (.0329) (-.300) (.659) [-.0297; 2.60] <-.0125>
XD/DB ; PHI/DA 1.55 (0) (1.45) [.174; 2.22] [-.00977; 6.03] <403.3>

YD/DA ; THE/DB -98.4 (.0365) (.864) [.151; 2.18] <-14.7>
ZD/DB ; PHI/DA 8.74 (0) (.0585) [.175; 2.22] [.280; 7.00] <123.0>
XD/DC ; PHI/DA 15.3 (0) (.691) (-4.71) [-.192; 2.15] <-231.0>

YD/DP ; THE/DB 2.08 (.0372) (.864) (-3.56) (6.14) [.740; 3.66] <-19.6>
ZD/DC ; PHI/DA -36.5 (0) (.145) [.223; 2.36] [.708; 2.37] <-165.0>

PHI/DA ; THE/DB ; PSI/DP -5.02 (.0364) (.0750) (.867) <-.0119>
PHI/DC ; THE/DB ; PSI/DP -4.37 (.0146) (.0379) (1.27) <-.000305>
THE/DC ; PHI/DA ; PSI/DP 4.47 (.0370) (.0746) (.590) <.00729>

PSI/DC ; PHI/DA ; THE/DB -1.22 (.0364) (.0980) (.913) <-.00397>
XD/DB ; PHI/DA ; PSI/DP 2.63 (.0744) (1.44) [-.00690; 6.04] <10.3>
YD/DA ; THE/DB ; PSI/DP -1.69 (.0370) (.863) [.0968; 9.88] <-5.25>

ZD/DC ; PHI/DA ; THE/DB 31.5 (0) (.0369) [.155; 2.21] <5.71>
ZD/DC ; PHI/DA ; PSI/DP -61.3 (.0751) (.148) [.729; 2.55] <-4.42>
XD/DC ; PHI/DA ; THE/DB -3.30 (0) (-.00495) [.173; 2.15] <.0755>

XD/DC ; PHI/DA ; PSI/DP 26.3 (.0748) (.695) (-4.42) <-6.03>
YD/DP ; PHI/DA ; THE/DB 4.46 (.0367) (.856) (3.69) (-3.88) <-2.00>
ZD/DB ; PHI/DA ; PSI/DP 14.4 (.0565) (.0780) [.280; 7.07] <3.19>

ZD/DC ; PHI/DA ; THE/DB ; PSI/DP 54.8 (.0362) (.0759) <.151>
XD/DC ; PHI/DA ; THE/DB ; PSI/DP -5.58 [.959; .0559] <-.0174>

TABLE III-5 CONTINUED
BO-105C TRANSFER FUNCTION FACTORS

CASE 36 120KT

DENOMINATOR: (0) (.0487) (.393) (6.63) (7.84) [-.920;.603][.142;2.42]<2.12>

CONTROL NUMERATORS:

PHI/DA 2.69 (0) (.376) (5.59) [-.937;.598][.198;2.44]<12.0>
THE/DB -1.17 (0) (.0310) (.0696) (.866) (9.42) [.156;2.43]<-.122>
PSI/DP 1.71 (.373)[- .0825;.495][-.922;.594][.999;7.19]<2.85>

PHI/DB .469 (0) (.949) (-2.80) [-.120;.586][.193;3.17]<-4.30>
THE/DA -1.79 (0) (.981)[- .403;.0400][.264;2.44]<-.0168>

PHI/DA ;THE/DB -3.22 (0) (.0435) (.866) [.205;2.45]<-.726>
PHI/DA ;PSI/DP 4.59 (.0896) (.374) (5.64) [-.937;.598]<.310>
THE/DB ;PSI/DP -2.03 (.0446) (.867) (9.39) [-.0723;.492]<-.178>

PHI/DB ;PSI/DP .936 (-2.83) [-.624;.206][.652;.759]<-.0652>
PHI/DP ;THE/DB 1.54 (0) (.0447) (.866) (-3.50) (5.35) <-1.12>
PHI/DC ;THE/DB 1.64 (0) (.0449) (.854) (-7.14) <-.450>

THE/DA ;PSI/DP -3.08 (-.208) (1.09) [-.961;.163]<.0185>
THE/DP ;PHI/DA .873 (0) (.133) (.529) (-.630) (3.14) <-.121>
THE/DC ;PHI/DA 3.60 (0) (.0395) (.534) [.244;2.32]<.408>

PSI/DA ;THE/DB 1.56 (.0435) (.863) (-1.94) <-.114>
PSI/DB ;PHI/DA .262 (.0527) (-1.02) (1.35) [-.856;1.27] <-.0308>
XD/DB ;PHI/DA 1.19 (0) (2.54) [.209;2.43] [-.159;5.42] <521.0>

YD/DA ;THE/DB -1.15 (.0436) (.862) [-.186;2.35] [.136;9.82] <-23.0>
ZD/DB ;PHI/DA 11.0 (0) (.0760) [.204;2.45] [.287;7.05] <249.0>
XD/DC ;PHI/DA 2.94 (0) (.705) (-3.35) (7.90) [.216;2.34] <-300.0>

YD/DP ;THE/DB 2.24 (.0446) (.868) (-4.30) (6.43) [-.721;3.88] <-36.1>
ZD/DC ;PHI/DA -39.7 (0) (.161) [-.644;2.42] [.282;2.76] <-286.0>

PHI/DA ;THE/DB ;PSI/DP -5.57 (.0437) (.0900) (.868) <-.0190>
PHI/DC ;THE/DB ;PSI/DP -.620 (.0234) (.0429) (1.02) <-.000633>
THE/DC ;PHI/DA ;PSI/DP 5.73 (.0434) (.0894) (.534) <.0119>

PSI/DC ;PHI/DA ;THE/DB -1.85 (.0437) (.109) (.818) <-.00723>
XD/DB ;PHI/DA ;PSI/DP 2.06 (.0893) (2.52) [-.151;5.39] <13.5>
YD/DA ;THE/DB ;PSI/DP -2.00 (.0443) (.862) [-.136;9.71] <-7.20>

ZD/DC ;PHI/DA ;THE/DB 32.8 (0) (.0452) [.177;2.43] <8.77>
ZD/DC ;PHI/DA ;PSI/DP -68.4 (.0901) (.168) [.687;2.78] <-8.03>
XD/DC ;PHI/DA ;THE/DB -5.10 (0) (-.0145) [-.199;2.32] <.401>

XD/DC ;PHI/DA ;PSI/DP 5.18 (.0897) (.700) (-3.13) (7.85) <-7.99>
YD/DP ;PHI/DA ;THE/DB 4.65 (.0440) (.849) (4.52) (-4.90) <-3.85>
ZD/DB ;PHI/DA ;PSI/DP 18.5 (.0727) (.0956) [.290;7.15] <6.57>

ZD/DC ;PHI/DA ;THE/DB ;PSI/DP 59.9 (.0438) (-.0916) <.240>
XD/DC ;PHI/DA ;THE/DB ;PSI/DP -8.86 (.0391) (-.0786) <-.0272>

TABLE III-5 CONTINUED
 B0-105C TRANSFER FUNCTION FACTORS

CASE 37 I45KT

DENOMINATOR: (0) (.0537) (-.437) (.532) (-1.07) [.0614; 2.21] [.995; 7.41] <3.58>

CONTROL NUMERATORS:

PHI/DA	2.77	(0)	(-.319)	(.393)	(-1.40)	(6.14)	[.179; 2.62]	<20.6>
THE/DB	-1.30	(0)	(.0264)	(.0862)	(.855)	(9.26)	[.116; 2.62]	<-.160>
PSI/DP	1.71	(-.323)	(.400)	(-1.24)	(-.275; .575)	(.997; 7.31)	<4.85>	
PHI/DB	.524	(0)	(4.00)	(-4.47)	(.323; .143)	(-.0522; 5.13)	<-5.03>	
THE/DA	-2.40	(0)	(.890)	(-.0514; .111)	(.284; 2.95)	<-.228>		
PHI/DA ; THE/DB	-3.65	(0)	(.0518)	(.830)	(.191; 2.81)	<-1.24>		
PHI/DA ; PSI/DP	4.77	(.106)	(-.314)	(.401)	(-1.33)	(5.98)	<.504>	
THE/DB ; PSI/DP	-2.22	(.0527)	(.889)	(9.18)	(-.255; .561)	<-.299>		
PHI/DB ; PSI/DP	.869	(.479)	(2.04)	(-4.72)	(.252; .157)	<-.0990>		
PHI/DP ; THE/DB	1.78	(0)	(.0528)	(.890)	(-4.15)	(6.60)	<-2.29>	
PHI/DC ; THE/DB	.646	(0)	(.0526)	(.573)	(-6.21)	(9.96)	<-1.20>	
THE/DA ; PSI/DP	-4.27	(-.150)	(1.16)	(.649; .191)	<.0270>			
THE/DP ; PHI/DA	1.35	(0)	(-.624)	(3.09)	(.765; .312)	<-1.253>		
THE/DC ; PHI/DA	4.79	(0)	(.0456)	(.535)	(.255; 2.41)	<.678>		
PSI/DA ; THE/DB	-.712	(.0517)	(.814)	(-1.08)	(-4.97)	<-.160>		
PSI/DB ; PHI/DA	-26.0	(.0236)	(.388; .147)	<-.0133>				
XD/DB ; PHI/DA	3.40	(0)	(.234; 2.47)	(-.902; 5.89)	<722.>			
YD/DA ; THE/DB	-1.48	(.0518)	(.832)	(.203; 2.57)	(.192; 9.61)	<-39.2>		
ZD/DB ; PHI/DA	13.8	(0)	(.0964)	(.165; 2.81)	(.293; 7.10)	<529.>		
XD/DC ; PHI/DA	6.46	(0)	(.902)	(-2.25)	(5.01)	(.186; 2.46)	<-395.>	
YD/DP ; THE/DB	2.31	(.0526)	(.896)	(-5.47)	(7.14)	(.677; 4.15)	<-73.3>	
ZD/DC ; PHI/DA	-43.0	(0)	(.184)	(.546; 2.34)	(.284; 3.49)	<-526.>		
PHI/DA ; THE/DB ; PSI/DP	-6.26	(.0513)	(.107)	(.886)	<-.0305>			
PHI/DC ; THE/DB ; PSI/DP	-1.08	(.00576)	(.0554)	(.754)	<-.000260>			
THE/DC ; PHI/DA ; PSI/DP	6.55	(.0540)	(.105)	(.534)	<.0199>			
PSI/DC ; PHI/DA ; THE/DB	-4.48	(.0514)	(.126)	(.548)	<-.0159>			
XD/DB ; PHI/DA ; PSI/DP	5.82	(.106)	(-4.50)	(-6.36)	<17.7>			
YD/DA ; THE/DB ; PSI/DP	-2.57	(.0525)	(.877)	(.213; 9.35)	<-10.3>			
ZD/DC ; PHI/DA ; THE/DB	32.9	(0)	(.0554)	(.113; 2.80)	<14.3>			
ZD/DC ; PHI/DA ; PSI/DP	-77.4	(.107)	(.211)	(.625; 2.91)	<-14.8>			
XD/DC ; PHI/DA ; THE/DB	-8.93	(0)	(-.00114)	(.156; 2.44)	<.0607>			
XD/DC ; PHI/DA ; PSI/DP	11.6	(.106)	(.845)	(-1.89)	(4.95)	<-9.73>		
YD/DP ; PHI/DA ; THE/DB	4.45	(.0520)	(.854)	(5.67)	(-6.67)	<-7.47>		
ZD/DB ; PHI/DA ; PSI/DP	23.8	(.0873)	(.119)	(.281; 7.27)	<13.0>			
ZD/DC ; PHI/DA ; THE/DB ; PSI/DP	69.0	(.0500)	(.111)	<.381>				
XD/DC ; PHI/DA ; THE/DB ; PSI/DP	-15.8	(.999; .0830)	<-.109>					

TABLE III-5 CONTINUED
BO-105C TRANSFER FUNCTION FACTORS

CASE 40 60KT 1000 FT/MIN CLIMB

DENOMINATOR: (0) (.235) (.426) (4.73) (7.61) [-.0140; .428] [-.0196; .552] <.201>

CONTROL NUMERATORS:

PHI/DA 2.49 (0) (.00538) (.236) (.443) (4.41) [-.0384; .442] <.00121>
THE/DB -.916 (0) (.00103) (.235) (.423) (8.78) [.000948; .538] <-.000239>
PSI/DP 1.18 (.262) (4.77) (7.66) [-.0325; .444] [-.0235; .524] <.608>

PHI/DB .672 (0) (-.00319) (.235) (-.382) (.389) [.966; .755] <.428E-4>
THE/DA .249 (0) (.0128) (.250) [.830; 1.00] [-.710; 1.09] <.000942>

PHI/DA ;THE/DB -2.45 (0) (.00126) (.00508) (.236) (.440) <-.163E-5>
PHI/DA ;PSI/DP 2.95 (.00284) (.262) (4.43) [-.0379; .443] <.00191>
THE/DB ;PSI/DP -1.09 (0) (.262) (8.89) [-.0173; .524] <-.695>

PHI/DB ;PSI/DP .842 (-.00422) (.262) (-.375) [.989; .698] <.000170>
PHI/DP ;THE/DB .641 (0) (.00126) (-.113) (.118) (.259) <-.278E-5>
PHI/DC ;THE/DB .144 (0) (0) (-.234) [-.573; .304] <.00310>

THE/DA ;PSI/DP .289 (-.0938) (.210) (-.754) [.612; .485] <.00101>
THE/DP ;PHI/DA .541 (0) (.00116) (.00972) (.253) (2.07) <.321E-5>
THE/DC ;PHI/DA .500 (0) (.231) [.923; .0128] <.189E-4>

PSI/DA ;THE/DB -.0398 (0) (.257) (2.19) [-.640; 3.02] <-.204>
PSI/DB ;PHI/DA .140 (-.00871) (.250) (1.15) [-.0994; .424] <-.631E-4>
XD/DB ;PHI/DA 1.98 (0) (.00554) (.236) (.440) [.160; 6.30] <.0454>

YD/DA ;THE/DB -78.7 (0) (0) (.239) (.429) <-8.08>
ZD/DB ;PHI/DA .0396 (0) (-.531) [.750; .0529] [.943; 2.70] <-.000431>
XD/DC ;PHI/DA -.589 (0) (.0140) (.231) [-.306; 5.23] <-.0523>

YD/DP ;THE/DB 1.26 (0) (.0115) (.0558) (.347) (3.41) (4.51) <.00431>
ZD/DC ;PHI/DA -19.2 (0) (.00337) (.277) (4.41) [-.0371; .442] <-.0155>

PHI/DA ;THE/DB ;PSI/DP -2.93 (.00129) (.00243) (.262) <-.241E-5>
PHI/DC ;THE/DB ;PSI/DP -.246 (0) (-.193) (.266) <.0126>
THE/DC ;PHI/DA ;PSI/DP -.391 (-.0142) (.0202) (.166) <.186E-4>

PSI/DC ;PHI/DA ;THE/DB -1.60 (0) (.0130) (.229) <-.00477>
XD/DB ;PHI/DA ;PSI/DP 2.37 (.00284) (.262) [.159; 6.31] <.0701>
YD/DA ;THE/DB ;PSI/DP -94.3 (0) (.261) <-24.6>

ZD/DC ;PHI/DA ;THE/DB 18.9 (0) (.275) [.953; .00231] <.276E-4>
ZD/DC ;PHI/DA ;PSI/DP -22.9 (.00431) (4.43) [-.0378; .443] <-.0855>
XD/DC ;PHI/DA ;THE/DB .0614 (0) (.0173) (.239) (-2.51) <-.000636>

XD/DC ;PHI/DA ;PSI/DP .140 (.00535) (.152) [-.0386; 9.54] <.0103>
YD/DP ;PHI/DA ;THE/DB 2.87 (0) (.00125) [.820; .171] <.000105>
ZD/DB ;PHI/DA ;PSI/DP .0400 (-.00137) (-2.97) [.295; 1.22] <.000241>

ZD/DC ;PHI/DA ;THE/DB ;PSI/DP 22.7 (.00115) (.00404) <.000106>
XD/DC ;PHI/DA ;THE/DB ;PSI/DP .175 (.0535) (-.0744) <-.000695>

TABLE III-5 CONCLUDED
BO-105C TRANSFER FUNCTION FACTORS

CASE 41 60 KT 1000 FT/MIN DESCENT

DENOMINATOR: (0) (-.0357) (.305) (6.00) [-.606; .491] [.125; 2.01] <.669>

CONTROL NUMERATORS:

PHI/DA 2.47 (0) (.306) (5.66) [-.611; .492] [.142; 2.01] <4.20>
THE/DB -12.2 (0) (.0281) (.0392) (.624) [-.133; 2.00] <-.0335>
PSI/DP 13.4 (.306) (6.19) [.0263; .438] [-.615; .493] <1.18>

PHI/DB .733 (0) (.246) (-.288) [-.200; 1.52] [.459; 3.01] <-1.08>
THE/DA .231 (0) (.0288) (.724) [.102; .881] [.192; 1.87] <.0130>

PHI/DA ; THE/DB -2.71 (0) (.0277) (.625) [.149; 2.01] <-.189>
PHI/DA ; PSI/DP 3.21 (.0549) (.307) (5.77) [-.614; .494] <.0760>
THE/DB ; PSI/DP -16.0 (.0282) (.623) [-.0251; .438] <-.0537>

PHI/DB ; PSI/DP 1.05 (-.315) [.807; .124] [.390; 1.72] <-.0152>
PHI/DP ; THE/DB .907 (0) (.0282) (.622) (-3.62) (4.88) <-.281>
PHI/DC ; THE/DB .220 (0) (.0275) (.760) (-4.74) (5.83) <-.127>

THE/DA ; PSI/DP .301 (-.139) (-.297) (.885) [.334; .482] <.00255>
THE/DP ; PHI/DA .610 (0) (-.0540) (1.91) [.835; .441] <-.0123>
THE/DC ; PHI/DA 2.63 (0) (.0287) (.390) [-.190; 1.93] <.110>

PSI/DA ; THE/DB -.441 (.0277) (.625) [-.133; 2.16] <-.0357>
PSI/DB ; PHI/DA .257 (.0198) (-.247) (-.386) [-.699; 2.48] <-.00297>
XD/DB ; PHI/DA 1.71 (0) (.799) [.151; 2.00] [-.0370; 6.31] <218.>

YD/DA ; THE/DB -88.5 (.0277) (.624) [.146; 1.98] <-6.03>
ZD/DB ; PHI/DA 5.88 (0) (.0436) [-.151; 2.01] [.366; 6.92] <49.8>
XD/DC ; PHI/DA -77.9 (0) (.413) [-.181; 1.92] <-119.>

YD/DP ; THE/DB 1.54 (.0282) (.623) (-3.39) (8.91) [.712; 3.34] <-9.06>
ZD/DC ; PHI/DA -24.9 (0) (.143) [-.180; 2.17] [-.993; 2.20] <-80.9>

PHI/DA ; THE/DB ; PSI/DP -3.59 (.0276) (.0554) (.624) <-.00343>
PHI/DC ; THE/DB ; PSI/DP -.136 (.0298) (-.0536) (1.70) <.000369>
THE/DC ; PHI/DA ; PSI/DP 3.19 (.0321) (.0534) (.387) <.00211>

PSI/DC ; PHI/DA ; THE/DB -1.28 (.0277) (.0748) (.680) <-.00180>
XD/DB ; PHI/DA ; PSI/DP 2.26 (.0550) (.795) [.0404; 6.32] <3.94>
YD/DA ; THE/DB ; PSI/DP -116. (.0280) (.623) <-2.03>

ZD/DC ; PHI/DA ; THE/DB 21.1 (0) (.0275) [.116; 2.00] <2.34>
ZD/DC ; PHI/DA ; PSI/DP -32.7 (.0558) (.151) (2.12) (2.61) <-1.53>
XD/DC ; PHI/DA ; THE/DB -1.91 (0) (.0540) [-.154; 1.90] <-.372>

XD/DC ; PHI/DA ; PSI/DP 10.6 (.0546) (.408) (-8.88) <-2.09>
YD/DP ; PHI/DA ; THE/DB 3.30 (.0278) (.619) (3.14) (-3.24) <-.578>
ZD/DB ; PHI/DA ; PSI/DP 7.55 (.0420) (.0575) [.372; 7.04] <.905>

ZD/DC ; PHI/DA ; THE/DB ; PSI/DP 29.0 (.0269) (.0563) <.0440>
XD/DC ; PHI/DA ; THE/DB ; PSI/DP -2.48 [.970; .0787] <-.0153>

SECTION IV

BELL AH-1G

The AH-1G is a single turbine attack aircraft intended specifically for armed helicopter missions. It combines the basic transmission, rotor system, and power plant of the UH-1C but differs in the fuselage. The aircraft carries a crew of two seated in tandem with the pilot aft and the copilot/gunner forward. Both have a full set of flight controls, however. (Only the pilot's controls are described in Fig. IV-1.)

The rotor system consists of a two-bladed, all metal, semi-rigid main rotor with an underslung feathering axis hub, and is powered by a Lycoming T53-L-13 turbo-shaft engine derated to 1100 shaft horsepower.

Figure IV-2 describes the flight control system which is composed of a conventional mechanically actuated hydraulic boost system plus an electronically actuated three-axis stability and control augmentation system (SCAS). An all movable elevator is mechanically linked to the longitudinal swash-plate with a non-linear gearing. The aircraft is normally operated with the SCAS engaged. Both hydraulic boost lags and SCAS actuator lags are neglected here. According to Ref. 5 the latter are 0.08 seconds in the cyclic controls and 0.05 seconds in the yaw control.

The derivative data presented here were produced by the AGAJ7407 version of the manufacturer's C81 Rotorcraft Flight Simulation Computer Program.

As shown in Fig. IV-1, the AH-1G airframe is configured with stub wings to carry armament and to help unload the rotor in cruising flight. The wings produce a slight downwash effect on the elevator which creates a non-zero M_w stability derivative. The role of the M_w derivative in the vehicle dynamics was estimated to be so small, however, that it was not tabulated nor was it included in the calculation of transfer functions.

Ref. 5, the basic data source, contains a detailed description of the AH-1G flight control system including block diagram, mechanical linkage schematics, and a verbal description. In addition, several detailed loading breakdowns are included.

Preceding page blank

TABLE IV-1

AH-1G DESCRIPTIVE DATA

MAIN ROTOR

Blades 2
 Radius 6.706 m (22 ft)
 Chord 0.686 m (2.25 ft)
 Section 9.33% thickness, special symmetrical section
 Hub type Teetering
 Undersling 11.4 cm (4.5 in)
 Twist -10 deg
 Pitch flap coupling (δ_3) Zero
 Shaft tilt Zero
 Design rpm 314 to 324 (power on), 294 to 339 (power off)*
 Hub location FS 200, WL 152.76†
 Blade flapping inertia 1873.44 kg-m² (1381.8 slug-ft²)

TAIL ROTOR

Blades 2
 Radius 1.295 m (4.25 ft)
 Chord 0.214 m (0.701 ft)
 Twist Zero
 Gear ratio 5.123
 Hub location FS 520.7, WL 118.27, BL -14.85

WING

Area 2.583 m² (27.8 ft²)
 Aspect ratio 3.91
 Center of pressure location FS 192.0, BL 39.0, WL 62.0
 Incidence 14 deg
 Dihedral 3.5 deg

ELEVATOR (EACH SIDE, EXCLUDING FUSELAGE CARRY-THROUGH)

Area 0.683 m² (7.35 ft²)
 Aspect ratio 1.49
 Center of pressure location FS 398.5, BL + 22.07, WL 56.0
 Incidence Variable

VERTICAL STABILIZER

Area 1.728 m² (18.60 ft²)
 Aspect ratio 1.56
 Center of pressure location FS 501.0, WL 84.0

* From Ref. 10.

† Manufacturer's fuselage reference system.

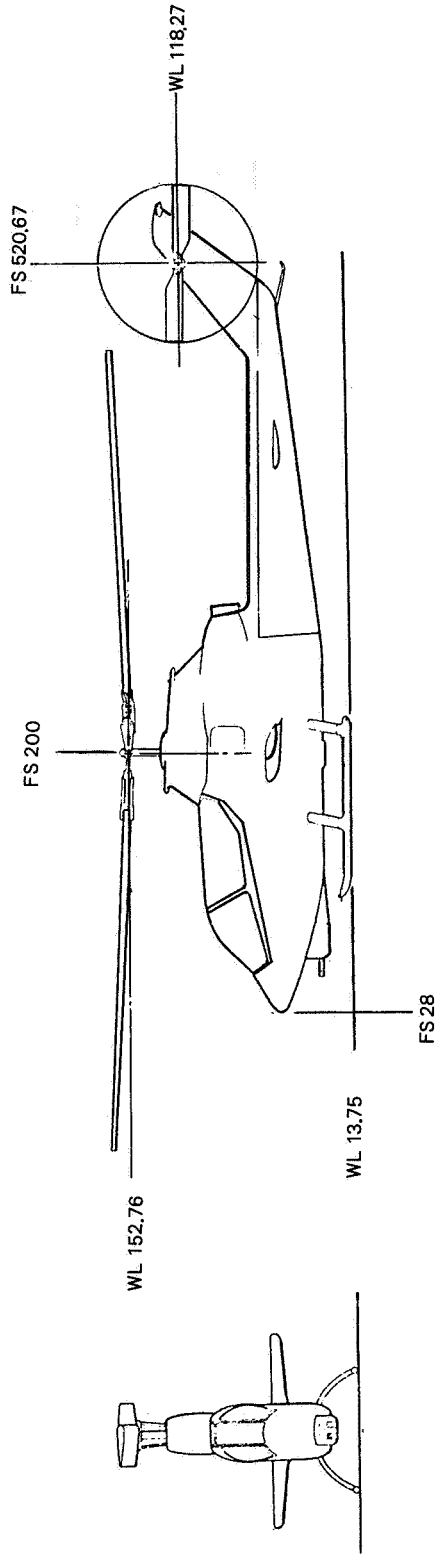
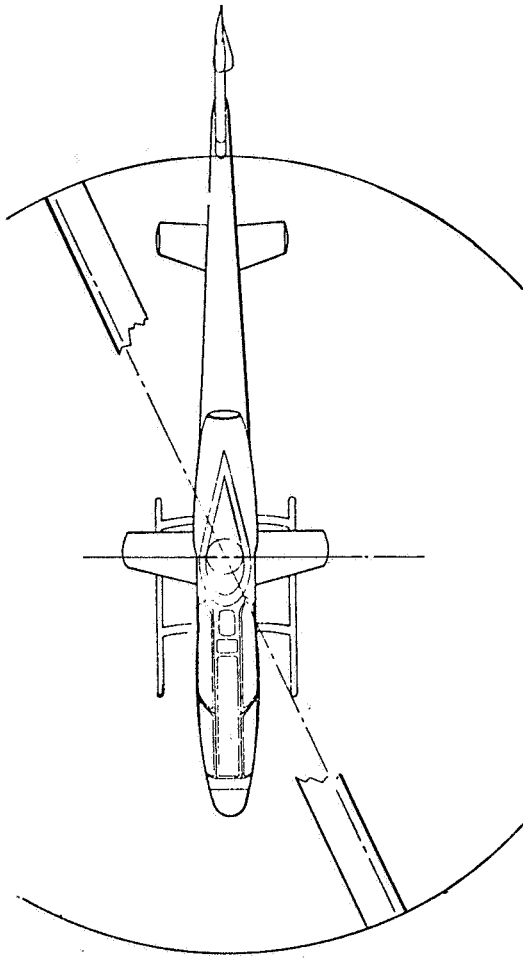
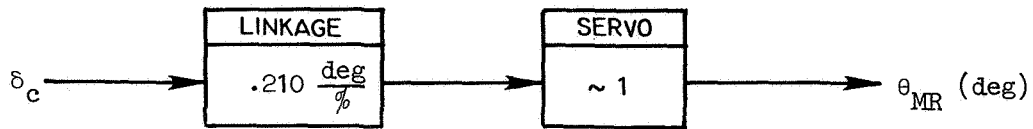

Figure IV-1. AH-13 General Arrangement

a. Block Diagram

COLLECTIVE



- All cockpit control deflections shown in this diagram have units of % full travel.

PITCH

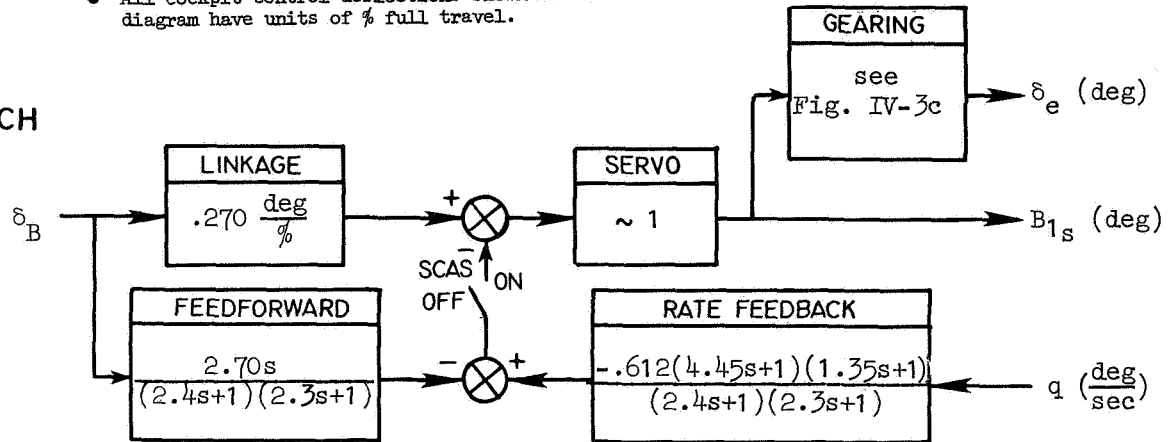

- SCAS authority equal to approximately + 12.5% full cockpit control travel — limiting is applied to sum of feedforward and feedback signals.

ROLL

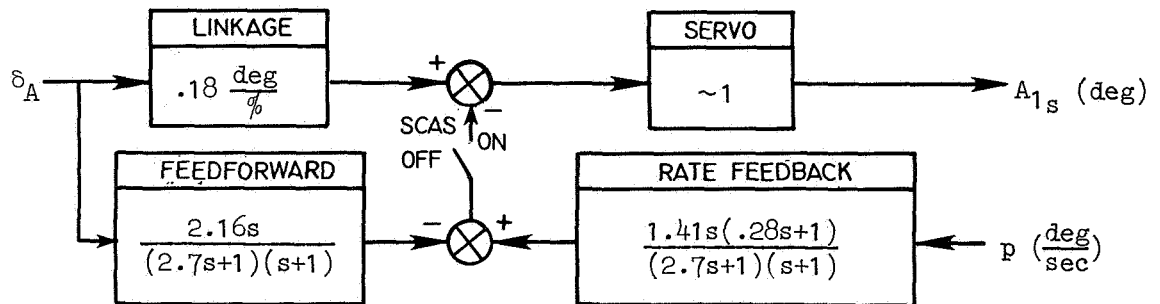

YAW

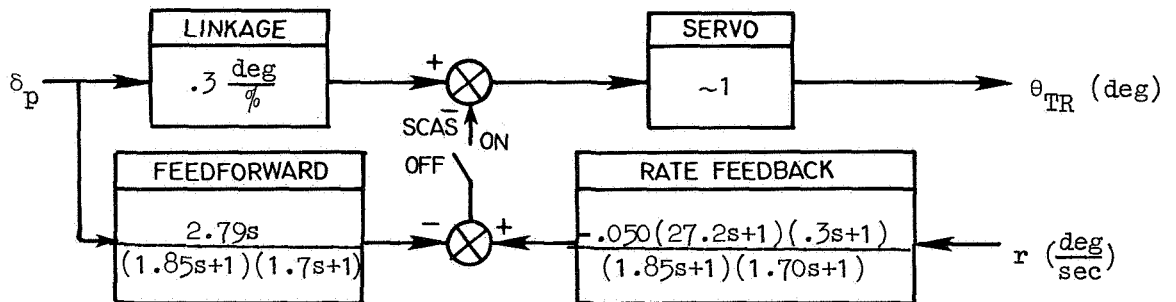

Figure IV-2. AH-1G Control System Description

b. Cockpit Controller Characteristics

CONTROLLER	100% FULL TRAVEL cm (in)	FORCE GRADIENT N/cm (lb/in)
Collective, δ_c	25.4 (10.)	—
Longitudinal Cyclic, δ_B	30.48 (12.)	2.12 (1.21)
Lateral Cyclic, δ_A	30.48 (12.)	1.73 (.99)
Pedal, δ_p	16.51 (6.5)	19.6 (11.2)

c. Swashplate-to-Elevator Gearing

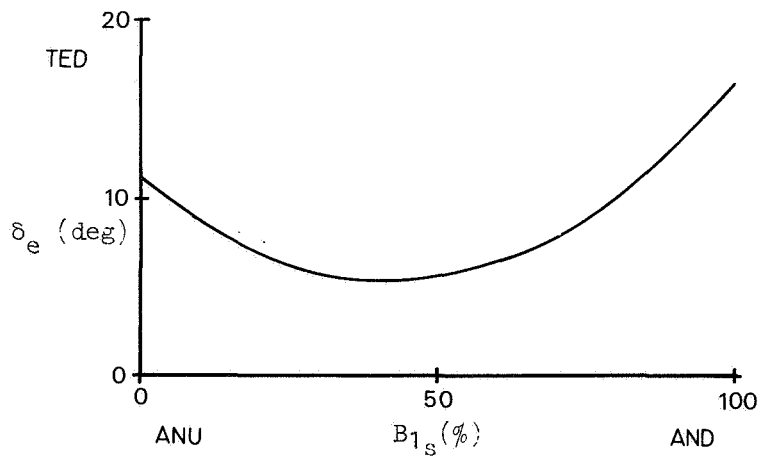
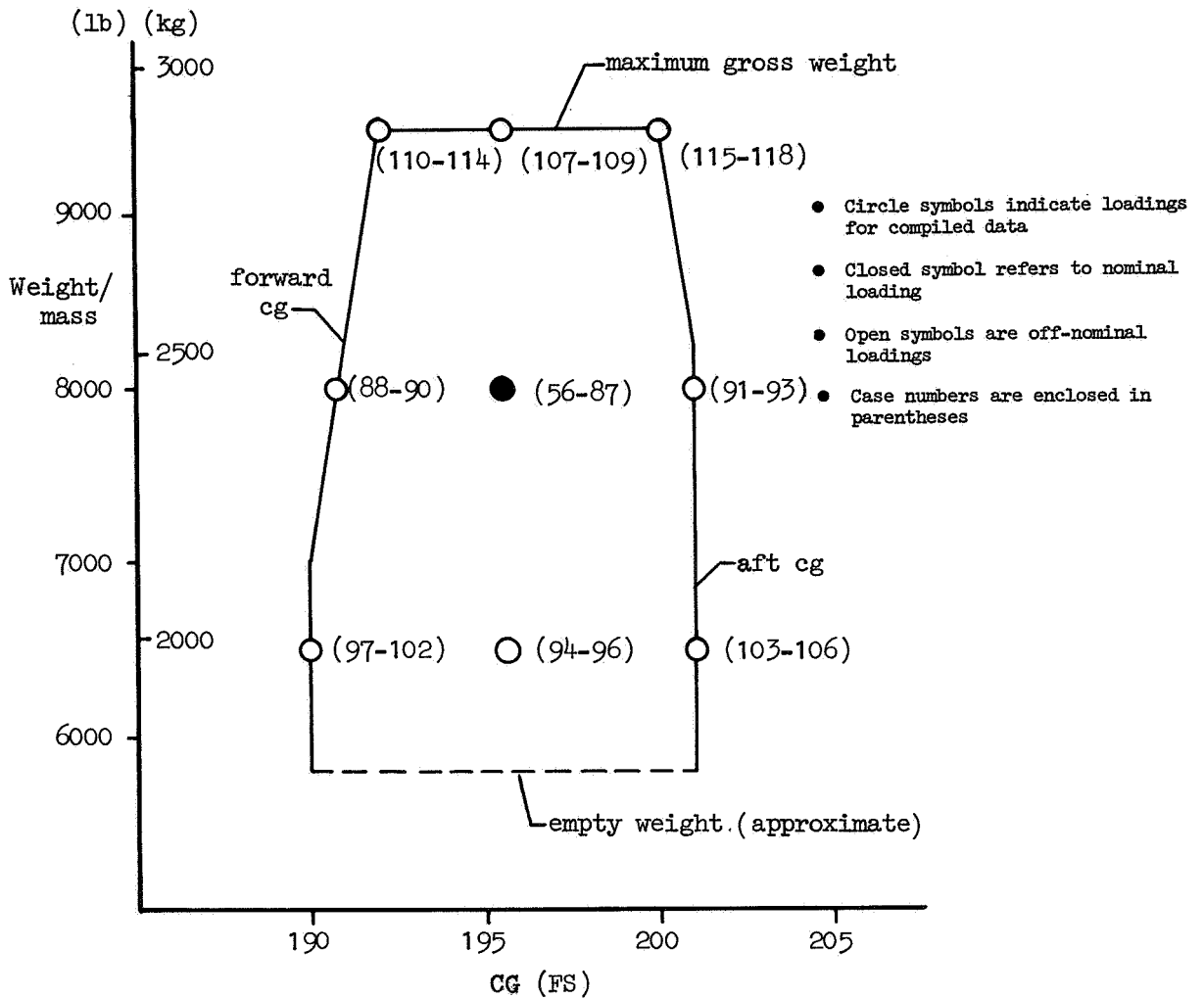

Figure IV-2 (Concluded)

a. Loading Envelope



b. Moments of Inertia for Compiled Data

CONDITION	MASS (WEIGHT) kg (lb)	CG		I_x	I_y kg-m ² (slug-ft ²)	I_z	I_{xz}
		FS	WL				
Nominal Weight	3629(8000)	190.8 to 201.0	73.0	3661(2700)	17354(12800)	14643(10800)	1288(950)
Light Weight	2948(6500)	190.0 to 201.0	78.0	2983(2200)	15863(11700)	13151(9700)	1288(950)
Heavy Weight	4309(9500)	192.0 to 200.0	68.0	4271(3150)	18032(13300)	16066(11850)	1288(950)

Figure IV-3. AH-1G Loading Summary

TABLE IV-2

AH-1G INDEX OF FLIGHT CONDITIONS
FOR DERIVATIVES AND TRANSFER FUNCTION FACTORS

CASE	CONDITION	AIRSPEED kt	VERTICAL VELOCITY m/sec(ft/sec)	ALTITUDE m(ft)	MASS (WEIGHT) kg(lb)	cg FS	REPORT PAGE NUMBER		
							DERIVA- TIVES SI(US)	TRANSFER FUNCTIONS	
								SCAS OFF	SCAS ON
56	Airspeed Variation	-40	Zero	Sea Level	3629(8000)	195.5	122(143)	164	
57	↓	-20	↓	↓	↓	↓	↓	165	
58	↓	-10	↓	↓	↓	↓	↓	166	
59	↓	Hover	↓	↓	↓	↓	123(144)	167*	171*
60	↓	10	↓	↓	↓	↓	↓	↓	↓
61	↓	20	↓	↓	↓	↓	↓	175*	179*
62	↓	40	↓	↓	↓	↓	124(145)	183	184
63	↓	60	↓	↓	↓	↓	↓	185*	189*
64	↓	80	↓	↓	↓	↓	↓	193	194
65	↓	100	↓	↓	↓	↓	125(146)	195	196
66	↓	120	↓	↓	↓	↓	↓	197	198
67	↓	140	↓	↓	↓	↓	↓	199	
68	Maximum Power Climb	Zero†	8.5(28.0)	↓	↓	↓	126(147)		
69	↓	60	11.9(39.0)	↓	↓	↓	↓	200	201
70	↓	100	10.6(34.9)	↓	↓	↓	↓	↓	↓
71	Autorotation	60	-9.5(-31.1)	↓	↓	↓	127(148)	202	203
72	↓	100	-11.4(-37.5)	↓	↓	↓	↓	↓	↓
73	Descent	Zero†	-3.0(-10)	↓	↓	↓	↓	↓	↓
74	↓	↓	-6.1(-20)	↓	↓	↓	128(149)		
75	Climb	↓	3.0(10)	↓	↓	↓	↓	↓	↓
76	↓	↓	6.1(20)	↓	↓	↓	↓	↓	↓
77	↓	60	6.1(20)	↓	↓	↓	129(150)	204	
78	↓	↓	3.0(10)	↓	↓	↓	↓	↓	↓
79	Descent	↓	-3.0(-10)	↓	↓	↓	↓	↓	↓
80	↓	↓	-6.1(-20)	↓	↓	↓	130(151)		
81	Operation at Altitude	Hover	Zero	3048(10000)	↓	↓	↓	205	
82	↓	60	↓	↓	↓	↓	↓	↓	↓
83	↓	100	↓	↓	↓	↓	131(152)		
84	Maximum Climb at Altitude	Zero†	6.1(20)	↓	↓	↓	↓	↓	↓
85	↓	60	8.5(28.0)	↓	↓	↓	↓	↓	↓
86	Autorotation at Altitude	↓	-8.5(-27.8)	↓	↓	↓	132(153)		
87	↓	100	-9.1(-30.0)	↓	↓	↓	↓	↓	↓
88	Fwd cg, Nominal Weight	Hover	Zero	Sea Level	↓	190.8	↓	↓	↓
89	↓	60	↓	↓	↓	↓	133(154)		
90	↓	100	↓	↓	↓	↓	↓	↓	↓
91	Aft cg, Nominal Weight	Hover	↓	↓	↓	201.0	↓	206	
92	↓	60	↓	↓	↓	↓	134(155)		
93	↓	100	↓	↓	↓	↓	↓	↓	↓
94	Light Weight	Hover	↓	↓	2948(6500)	195.5	↓	↓	↓
95	↓	60	↓	↓	↓	↓	135(156)	207	208
96	↓	100	↓	↓	↓	↓	↓	↓	↓
97	Fwd cg, Light Weight	Hover	↓	↓	↓	190.0	↓	↓	↓
98	↓	60	↓	↓	↓	↓	136(157)		
99	...and Maximum Climb	Zero†	14.4(47.4)	↓	↓	↓	↓	↓	↓
100	↓	60	14.6(48.0)	↓	↓	↓	↓	209	
101	...and Autorotation	Zero†	-15.2(-50.0)	↓	↓	↓	137(158)		
102	↓	60	-8.5(-28.0)	↓	↓	↓	↓	↓	↓
103	Aft cg, Light Weight	Hover	Zero	↓	↓	201.0	↓	↓	↓
104	↓	60	Zero	↓	↓	↓	138(159)		
105	...and Maximum Climb	↓	15.5(50.9)	↓	↓	↓	↓	↓	↓
106	...and Autorotation	↓	-8.8(-29.0)	↓	↓	↓	↓	↓	↓
107	Heavy Weight	Hover	Zero	↓	4309(9500)	195.5	139(160)	210	
108	↓	60	↓	↓	↓	↓	↓	211	
109	↓	100	↓	↓	↓	↓	↓	↓	↓
110	Fwd cg, Heavy Weight	Hover	↓	↓	↓	192.0	140(161)		
111	↓	60	↓	↓	↓	↓	↓	↓	↓
112	...and Maximum Climb	Zero†	3.7(12.0)	↓	↓	↓	↓	↓	↓
113	↓	60	9.6(31.4)	↓	↓	↓	141(162)		
114	...and Autorotation	60	-8.1(-26.5)	↓	↓	↓	↓	↓	↓
115	Aft cg, Heavy Weight	Hover	Zero	↓	↓	200.0	↓	↓	↓
116	↓	60	Zero	↓	↓	↓	142(163)		
117	...and Maximum Climb	↓	9.8(32.2)	↓	↓	↓	↓	↓	↓
118	...and Autorotation	↓	-8.8(-28.8)	↓	↓	↓	↓	↓	↓

* Extended list of transfer function factors.

† Zero forward velocity, i.e., airspeed is equal to vertical velocity.

TABLE IV-3
AH-IG STABILITY AND CONTROL DERIVATIVES -- SI UNITS
(BODY-FIXED FRL AXIS SYSTEM)

CASE	-40 KT		LEVEL FLIGHT AT SEA LEVEL			3629 KG	MID CG			
	PHI	THETA	PSI	ALPHA	BETA	GAMMA	ΘMR	B1S	A1S	ΘTR
	-0.75	-2.43	0.00	177.57	-0.03	180.00	12.72	-4.46	-0.13	3.41
	XDOT		ZDOT	U0	V0	W0	VTO			
	-20.58		0.00	-20.56	-0.01	0.87	20.58			
	U	W	Q	V	P	R	DC	DB	DA	DP
X	-0.0136	-0.0434	0.4997	-0.0021	-0.4583	0.0371	-0.0576	0.1401	0.0052	0.0224
Z	0.1286	-0.6508	0.0722	-0.0093	0.3117	0.5465	-1.6164	-0.2235	-0.0120	-0.0105
H	0.0059	0.0087	-0.1329	0.0021	0.1793	-0.0082	-0.0116	-0.0607	-0.0025	-0.0106
Y	-0.0019	-0.0249	-0.4672	-0.0429	-0.5620	0.1722	-0.0585	-0.0123	0.0989	0.1891
L'	0.0062	-0.0567	-0.7887	-0.0187	-1.0348	0.0873	-0.0582	-0.0285	0.1884	0.1216
M'	0.0151	-0.0261	0.3078	0.0214	-0.0414	-0.4312	0.1381	-0.0120	0.0131	-0.3219

CASE	-20 KT		LEVEL FLIGHT AT SEA LEVEL			3629 KG	MID CG			
	PHI	THETA	PSI	ALPHA	BETA	GAMMA	ΘMR	B1S	A1S	ΘTR
	-0.97	-2.95	0.00	177.05	-0.05	180.00	13.79	-3.99	-0.53	5.75
	XDOT		ZDOT	U0	V0	W0	VTO			
	-10.29		0.00	-10.28	-0.01	0.53	10.29			
	U	W	Q	V	P	R	DC	DB	DA	DP
X	0.0028	-0.0369	0.3434	-0.0032	-0.4651	0.0352	-0.0514	0.1619	0.0151	0.0470
Z	0.2097	-0.4833	-0.3042	-0.0246	0.1667	0.5448	-1.4700	-0.1050	-0.0091	-0.0117
H	0.0112	-0.0013	-0.1475	0.0031	0.1847	-0.0166	-0.0141	-0.0687	-0.0072	-0.0170
Y	0.0009	-0.0151	-0.4697	-0.0407	-0.4032	0.1762	-0.0437	0.0023	0.1074	0.1897
L'	0.0221	-0.0405	-0.8199	-0.0247	-0.7911	0.0787	-0.0156	-0.0022	0.2014	0.1257
M'	0.0251	-0.0179	0.3394	0.0273	-0.1375	-0.3874	0.1873	-0.0045	0.0139	-0.3029

CASE	-10 KT		LEVEL FLIGHT AT SEA LEVEL			3629 KG	MID CG			
	PHI	THETA	PSI	ALPHA	BETA	GAMMA	ΘMR	B1S	A1S	ΘTR
	-1.07	-1.92	0.00	178.08	-0.04	180.00	14.41	-2.79	-1.08	7.34
	XDOT		ZDOT	U0	V0	W0	VTO			
	-5.14		0.00	-5.14	-0.00	0.17	5.14			
	U	W	Q	V	P	R	DC	DB	DA	DP
X	-0.0208	-0.0211	0.2306	-0.0101	-0.5531	-0.0432	-0.0635	0.1377	-0.0033	-0.0108
Z	0.1777	-0.4042	-0.3425	-0.0405	0.1011	0.6155	-1.4819	-0.0299	0.0016	0.0125
H	0.0251	-0.0121	-0.2056	0.0052	0.2236	0.0162	0.0035	-0.0550	0.0016	0.0110
Y	0.0058	-0.0143	-0.5418	-0.0477	-0.3502	0.2117	-0.0563	-0.0086	0.1013	0.1693
L'	0.0313	-0.0237	-0.9046	-0.0241	-0.7256	0.0249	-0.0211	-0.0142	0.1954	0.1105
M'	0.0224	-0.0076	0.2937	0.0402	-0.2486	-0.4796	0.2129	-0.0058	0.0136	-0.3063

TABLE IV-3 CONTINUED
 AH-IG STABILITY AND CONTROL DERIVATIVES -- SI UNITS
 (BODY-FIXED FRL AXIS SYSTEM)

CASE 59 1 KT LEVEL FLIGHT AT SEA LEVEL 3629 KG MID CG

	PHI	THETA	PSI	ALPHA	BETA	GAMMA	ΘMR	B1S	A1S	ΘTR
	-1.15	-0.73	0.00	-0.73	0.01	0.00	14.83	-0.76	-1.80	8.40
	IDOT	ZDOT	UO	VO	WO	VTO				
	0.51	0.00	0.51	0.00	-0.01	0.51				
	U	W	Q	V	P	R	DC	DB	DA	DP
X	-0.0165	-0.0155	0.1114	-0.0285	-0.5639	-0.0373	-0.0307	0.1491	-0.0016	-0.0174
Z	-0.1208	-0.3726	-0.0034	-0.0932	-0.0410	0.6326	-1.5313	0.0216	-0.0004	-0.0037
M	0.0016	-0.0109	-0.2345	0.0022	0.2305	0.0175	0.0030	-0.0575	0.0014	0.0127
Y	0.0173	-0.0051	-0.4859	-0.0552	-0.3361	0.2189	-0.0662	-0.0142	0.0971	0.1540
L [*]	0.0280	-0.0198	-1.0559	-0.0285	-0.7662	-0.0403	-0.0364	-0.0270	0.1854	0.0715
M [*]	-0.0038	-0.0154	-0.1161	0.0518	-0.3945	-0.5366	0.2282	-0.0037	0.0126	-0.3197

CASE 60 10 KT LEVEL FLIGHT AT SEA LEVEL 3629 KG MID CG

	PHI	THETA	PSI	ALPHA	BETA	GAMMA	ΘMR	B1S	A1S	ΘTR
	-1.05	-1.10	0.00	-1.10	0.02	0.00	14.42	-0.69	-2.02	7.52
	IDOT	ZDOT	UO	VO	WO	VTO				
	5.14	0.00	5.14	0.00	-0.10	5.14				
	U	W	Q	V	P	R	DC	DB	DA	DP
X	-0.0163	-0.0106	0.2958	-0.0154	-0.5325	-0.0181	-0.0347	0.1578	0.0048	-0.0095
Z	-0.2090	-0.4060	0.2502	-0.0530	-0.0956	0.5975	-1.4829	0.0512	0.0020	-0.0025
M	0.0006	-0.0086	-0.2289	0.0055	0.2141	0.0049	0.0033	-0.0633	-0.0022	0.0014
Y	0.0180	0.0002	-0.4762	-0.0562	-0.3538	0.2458	-0.0389	0.0017	0.1064	0.1787
L [*]	0.0224	-0.0109	-0.9165	-0.0206	-0.8109	0.0164	0.0078	0.0029	0.2025	0.1235
M [*]	-0.0133	-0.0145	0.0522	0.0437	-0.4245	-0.5325	0.2140	-0.0003	0.0138	-0.3045

CASE 61 20 KT LEVEL FLIGHT AT SEA LEVEL 3629 KG MID CG

	PHI	THETA	PSI	ALPHA	BETA	GAMMA	ΘMR	B1S	A1S	ΘTR
	-0.91	-1.59	0.00	-1.59	0.03	0.00	13.81	-0.73	-2.12	6.11
	IDOT	ZDOT	UO	VO	WO	VTO				
	10.29	0.00	10.28	0.00	-0.28	10.29				
	U	W	Q	V	P	R	DC	DB	DA	DP
X	-0.0283	-0.0194	0.3800	-0.0130	-0.5282	-0.0190	-0.0526	0.1566	0.0032	-0.0062
Z	-0.2485	-0.5022	0.2704	-0.0429	-0.1489	0.5495	-1.4599	0.1017	0.0042	-0.0028
M	0.0015	-0.0059	-0.2289	0.0046	0.2102	0.0058	0.0102	-0.0622	-0.0013	0.0042
Y	0.0142	0.0000	-0.4800	-0.0599	-0.4485	0.2473	-0.0292	0.0004	0.1036	0.1635
L [*]	0.0117	-0.0069	-0.8171	-0.0209	-0.9880	0.0243	0.0167	0.0024	0.1975	0.1065
M [*]	-0.0210	-0.0122	0.1957	0.0190	-0.4410	-0.5473	0.1882	0.0028	0.0134	-0.2883

TABLE IV-3 CONTINUED
 AH-IG STABILITY AND CONTROL DERIVATIVES -- SI UNITS
 (BODY-FIXED FRL AXIS SYSTEM)

CASE	40 KT		LEVEL FLIGHT AT SEA LEVEL				3629 KG	MID CG		
	PHI	THETA	PSI	ALPHA	BETA	GAMMA	ΘMR	B1S	A1S	ΘTR
62	-0.71	-1.81	0.00	-1.31	0.02	0.00	12.77	-0.10	-1.93	3.49
	XDOT		ZDOT	U0	V0	W0	VT0			
	20.58		0.00	20.57	0.01	-0.65	20.58			
	U	W	Q	V	P	R	DC	DB	DA	DP
X	-0.0273	-0.0263	0.4762	-0.0084	-0.5034	-0.0299	-0.0651	0.1582	0.0019	-0.0090
Z	-0.1688	-0.7094	-0.0803	-0.0315	-0.2877	0.5040	-1.5941	0.2178	0.0063	-0.0084
M	0.0055	-0.0075	-0.2805	0.0022	0.1951	0.0149	0.0120	-0.0626	-0.0009	0.0060
Y	0.0081	0.0017	-0.4593	-0.0793	-0.5876	0.3129	-0.0085	0.0045	0.1020	0.1749
L*	0.0016	-0.0045	-0.7411	-0.0197	-1.2312	0.0250	0.0389	0.0129	0.1944	0.1157
N*	-0.0201	-0.0207	0.2837	0.0419	-0.4142	-0.7310	0.1441	0.0108	0.0116	-0.3087
CASE	60 KT		LEVEL FLIGHT AT SEA LEVEL				3629 KG	MID CG		
	PHI	THETA	PSI	ALPHA	BETA	GAMMA	ΘMR	B1S	A1S	ΘTR
63	-0.69	-2.25	0.00	-2.25	0.03	0.00	12.42	0.70	-1.54	2.39
	XDOT		ZDOT	U0	V0	W0	VT0			
	30.87		0.00	30.84	0.01	-1.21	30.87			
	U	W	Q	V	P	R	DC	DB	DA	DP
X	-0.0268	-0.0286	0.5233	-0.0046	-0.4897	-0.0204	-0.0811	0.1571	0.0020	-0.0061
Z	-0.1060	-0.8377	-0.4333	-0.0246	-0.4353	0.5395	-1.8011	0.3542	0.0088	-0.0102
M	0.0064	-0.0097	-0.3244	0.0000	0.1854	0.0199	0.0113	-0.0620	-0.0011	0.0060
Y	0.0006	-0.0003	-0.4302	-0.1019	-0.6232	0.3976	-0.0072	0.0023	0.1010	0.2087
L*	-0.0102	-0.0101	-0.6703	-0.0151	-1.2781	0.0375	0.0305	0.0090	0.1919	0.1342
N*	-0.0159	-0.0286	0.3029	0.0473	-0.3518	-0.8970	0.1156	0.0135	0.0106	-0.3713
CASE	80 KT		LEVEL FLIGHT AT SEA LEVEL				3629 KG	MID CG		
	PHI	THETA	PSI	ALPHA	BETA	GAMMA	ΘMR	B1S	A1S	ΘTR
64	-0.78	-2.71	0.00	-2.71	0.04	0.00	12.55	1.77	-1.31	2.02
	XDOT		ZDOT	U0	V0	W0	VT0			
	41.16		0.00	41.11	0.03	-1.94	41.16			
	U	W	Q	V	P	R	DC	DB	DA	DP
X	-0.0296	-0.0261	0.5384	-0.0027	-0.4727	-0.0304	-0.0822	0.1568	0.0019	-0.0128
Z	-0.0731	-0.9243	-0.7182	-0.0213	-0.6018	0.5313	-1.9722	0.5057	0.0115	-0.0124
M	0.0071	-0.0139	-0.3656	-0.0014	0.1734	0.0251	0.0077	-0.0637	-0.0017	0.0094
Y	0.0022	-0.0051	-0.4331	-0.1236	-0.5974	0.4672	-0.0113	0.0075	0.1022	0.2183
L*	-0.0070	-0.0185	-0.6943	-0.0107	-1.2282	0.0151	0.0168	0.0194	0.1934	0.1326
N*	-0.0138	-0.0306	0.2347	0.0492	-0.3160	-1.0518	0.1002	0.0181	0.0091	-0.4007

TABLE IV-3 CONTINUED
 AH-IG STABILITY AND CONTROL DERIVATIVES -- SI UNITS
 (BODY-FIXED FRL AXIS SYSTEM)

CASE	100 KT		LEVEL FLIGHT AT SEA LEVEL				3629 KG	MID CG			
	PHI	THETA	PSI	ALPHA	BETA	GAMMA	ΘHR	B1S	A1S	ΘTR	
	-0.99	-3.34	0.00	-3.34	0.06	0.00	13.06	3.06	-1.29	2.03	
		XDOT	ZDOT	U0	V0	W0		VT0			
		51.44	0.00	51.36	0.05	-3.00		51.44			
	U	W	Q	V	P	R	DC	DB	DA	DP	
X	-0.0353	-0.0206	0.5002	-0.0022	-0.4748	-0.0230	-0.0732	0.1509	0.0006	-0.0117	
Z	-0.0520	-0.9907	-0.9529	-0.0216	-0.7840	0.5695	-2.1192	0.6647	0.0146	-0.0191	
M	0.0084	-0.0191	-0.3849	-0.0022	0.1739	0.0329	0.0025	-0.0647	-0.0008	0.0117	
Y	0.0031	-0.0112	-0.4414	-0.1451	-0.5333	0.5279	-0.0234	0.0101	0.1007	0.2309	
L'	-0.0049	-0.0265	-0.7296	-0.0083	-1.1043	0.0254	-0.0027	0.0253	0.1912	0.1393	
N'	-0.0104	-0.0248	0.1597	0.0498	-0.3083	-1.1848	0.1078	0.0213	0.0103	-0.4220	

CASE	120 KT		LEVEL FLIGHT AT SEA LEVEL				3629 KG	MID CG			
	PHI	THETA	PSI	ALPHA	BETA	GAMMA	ΘHR	B1S	A1S	ΘTR	
	-1.32	-4.24	0.00	-4.24	0.10	0.00	14.03	4.67	-1.52	2.49	
		XDOT	ZDOT	U0	V0	W0		VT0			
		61.73	0.00	61.56	0.11	-4.56		61.73			
	U	W	Q	V	P	R	DC	DB	DA	DP	
X	-0.0416	-0.0105	0.4684	-0.0011	-0.4478	-0.0313	-0.0496	0.1420	0.0001	-0.0161	
Z	-0.0337	-1.0451	-1.0807	-0.0266	-0.9703	0.6303	-2.2473	0.8278	0.0184	-0.0192	
M	0.0096	-0.0263	-0.4074	-0.0036	0.1566	0.0391	-0.0081	-0.0694	-0.0008	0.0177	
Y	0.0044	-0.0204	-0.4495	-0.1659	-0.4162	0.6020	-0.0425	0.0189	0.1021	0.2396	
L'	-0.0025	-0.0358	-0.8015	-0.0087	-0.9010	0.0414	-0.0239	0.0382	0.1942	0.1422	
N'	-0.0077	-0.0091	-0.0174	0.0476	-0.3474	-1.3367	0.1443	0.0126	0.0113	-0.4407	

CASE	140 KT		LEVEL FLIGHT AT SEA LEVEL				3629 KG	MID CG			
	PHI	THETA	PSI	ALPHA	BETA	GAMMA	ΘHR	B1S	A1S	ΘTR	
	-1.79	-5.54	0.00	-5.54	0.17	0.00	15.57	6.59	-2.02	3.49	
		XDOT	ZDOT	U0	V0	W0		VT0			
		72.02	0.00	71.68	0.22	-6.95		72.02			
	U	W	Q	V	P	R	DC	DB	DA	DP	
X	-0.0514	0.0025	0.4110	0.0001	-0.4207	-0.0456	-0.0139	0.1300	-0.0003	-0.0216	
Z	-0.0204	-1.0982	-1.0444	-0.0374	-1.1782	0.7171	-2.3752	1.0107	0.0224	-0.0211	
M	0.0110	-0.0355	-0.4162	-0.0055	0.1370	0.0509	-0.0244	-0.0779	-0.0013	0.0273	
Y	0.0057	-0.0311	-0.4808	-0.1871	-0.2510	0.6740	-0.0728	0.0332	0.1053	0.2436	
L'	0.0001	-0.0419	-0.9581	-0.0134	-0.6099	0.0347	-0.0503	0.0503	0.1989	0.1388	
N'	-0.0041	0.0227	-0.2909	0.0448	-0.3934	-1.5129	0.2256	-0.0294	0.0105	-0.4516	

TABLE IV-3 CONTINUED
 AH-IG STABILITY AND CONTROL DERIVATIVES -- SI UNITS
 (BODY-FIXED FRL AXIS SYSTEM)

CASE 68	17 KT		9 M/S		SEA LEVEL	3629 KG	MID CG			
PHI	THETA	PSI	ALPHA	BETA	GAMMA	ΘMR	B1S	A1S	ΘTR	
-1.77	2.83	0.00	-87.17	1.76	90.00	16.91	2.19	-2.51	11.02	
	XDOT	ZDOT	U0	V0	W0	VTO				
	0.00	-8.53	0.42	0.26	-8.52	8.53				
	U	W	Q	Y	P	R	DC	DB	DA	DP
X	-0.0253	0.0123	0.0677	-0.0176	-0.5267	-0.0662	0.0741	0.1734	0.0047	0.0018
Z	-0.0497	-0.5069	-0.1913	-0.0966	-0.2048	0.7601	-1.5848	0.0157	-0.0003	-0.0050
H	-0.0004	-0.0443	-0.3009	-0.0016	0.2015	-0.0042	-0.0343	-0.0662	-0.0013	0.0226
Y	0.0102	-0.0293	-0.6573	-0.0809	-0.1428	0.3067	-0.0912	-0.0135	0.1058	0.1733
L*	0.0234	-0.0335	-1.3200	-0.0336	-0.4366	0.0156	-0.0552	-0.0325	0.1975	0.0802
M*	0.0056	0.0389	-0.3402	0.0694	-0.4774	-0.6729	0.3150	-0.0036	0.0130	-0.3445

CASE 69	60 KT		12 M/S		SEA LEVEL	3629 KG	MID CG			
PHI	THETA	PSI	ALPHA	BETA	GAMMA	ΘMR	B1S	A1S	ΘTR	
-1.80	1.13	0.00	-21.51	0.66	22.65	16.95	4.01	-3.09	8.05	
	XDOT	ZDOT	U0	V0	W0	VTO				
	28.48	-11.89	28.71	0.36	-11.32	30.87				
	U	W	Q	Y	P	R	DC	DB	DA	DP
X	-0.0245	0.0153	0.1094	-0.0035	-0.4721	-0.0873	0.0235	0.1670	0.0036	-0.0093
Z	-0.0444	-0.8153	-0.4804	-0.0526	-0.4973	0.8583	-1.8051	0.3436	0.0206	0.0113
H	0.0025	-0.0472	-0.2218	-0.0008	0.1638	0.0344	-0.0205	-0.0721	-0.0030	0.0181
Y	0.0052	-0.0244	-0.4927	-0.1062	-0.1300	0.5218	-0.0502	0.0227	0.1255	0.2317
L*	-0.0076	-0.0216	-0.9553	-0.0490	-0.4110	0.1426	0.0331	0.0349	0.2359	0.1922
M*	-0.0228	0.0414	-0.1438	0.0428	-0.5298	-1.0505	0.3342	-0.0150	0.0121	-0.3549

CASE 70	100 KT		11 M/S		SEA LEVEL	3629 KG	MID CG			
PHI	THETA	PSI	ALPHA	BETA	GAMMA	ΘMR	B1S	A1S	ΘTR	
-1.92	-1.04	0.00	-12.97	0.43	11.93	17.22	5.82	-2.66	6.21	
	XDOT	ZDOT	U0	V0	W0	VTO				
	50.33	-10.64	50.13	0.39	-11.54	51.44				
	U	W	Q	Y	P	R	DC	DB	DA	DP
X	-0.0401	0.0049	0.0852	0.0002	-0.4543	-0.0360	0.0074	0.1526	0.0019	-0.0262
Z	-0.0146	-0.9681	-0.8235	-0.0504	-0.8488	0.8860	-2.0987	0.6538	0.0226	0.0017
H	0.0112	-0.0344	-0.2293	-0.0053	0.1492	0.0753	-0.0226	-0.0722	-0.0011	0.0433
Y	0.0047	-0.0332	-0.5443	-0.1490	-0.1372	0.6081	-0.0807	0.0208	0.1167	0.2215
L*	-0.0051	-0.0293	-1.0096	-0.0444	-0.3952	0.9705	-0.0179	0.0222	0.2186	0.1334
M*	-0.0184	0.0542	-0.0673	0.0402	-0.4377	-1.3259	0.3521	-0.0362	0.0106	-0.4040

TABLE IV-3 CONTINUED
 AH-IG STABILITY AND CONTROL DERIVATIVES -- SI UNITS
 (BODY-FIXED FRL AXIS SYSTEM)

CASE	71	60 KT	-9 M/S	SEA LEVEL	3629 KG	MID CG				
	PHI	THETA	PSI	ALPHA	BETA	GAMMA	ΘMR	B1S	A1S	ΘTR
	-0.03	-3.88	0.00	14.01	-0.01	-17.89	8.69	-1.59	-0.39	-0.70
	XDOT	ZDOT	UO	VO	WO	VT0				
	29.37	9.48	29.95	-0.00	7.47	30.87				
	U	W	Q	V	P	R	DC	DB	DA	DP
X	-0.0213	-0.0798	0.8366	-0.0027	-0.4773	-0.0104	-0.1140	0.1512	0.0021	-0.0019
Z	-0.1501	-0.7429	-0.5698	-0.0104	-0.2885	0.3009	-1.7526	0.3224	0.0094	-0.0077
M	0.0047	-0.0187	-0.4218	-0.0012	0.1925	0.0166	0.0289	-0.0584	-0.0011	0.0013
Y	-0.0010	0.0152	-0.3903	-0.1254	-0.9360	0.3464	0.0347	-0.0030	0.0906	0.2102
L*	-0.0099	0.0052	-0.5360	0.0523	-1.8174	0.0115	0.0555	0.0070	0.1753	0.1235
M*	-0.0123	-0.0693	0.4954	0.0498	-0.1969	-0.8372	-0.0251	0.0351	0.0123	-0.3851
CASE	72	100 KT	-11 M/S	SEA LEVEL	3629 KG	MID CG				
	PHI	THETA	PSI	ALPHA	BETA	GAMMA	ΘMR	B1S	A1S	ΘTR
	-0.31	-5.09	0.00	7.75	-0.04	-12.84	8.04	-0.57	0.22	-0.89
	XDOT	ZDOT	UO	VO	WO	VT0				
	50.16	11.43	50.97	-0.04	6.94	51.44				
	U	W	Q	V	P	R	DC	DB	DA	DP
X	-0.0309	-0.0382	0.8812	-0.0012	-0.4641	-0.0064	-0.1434	0.1487	-0.0002	0.0015
Z	-0.0968	-0.9793	-1.1576	0.0052	-0.6000	0.1984	-2.0708	0.6436	0.0168	-0.0186
M	0.0039	-0.0099	-0.5269	-0.0025	0.1817	0.0106	0.0264	-0.0539	-0.0002	-0.0040
Y	0.0022	0.0187	-0.3727	-0.1615	-0.9219	0.4592	0.0404	-0.0090	0.0810	0.2319
L*	-0.0028	-0.0018	-0.5511	0.0465	-1.7892	-0.0033	0.0350	0.0114	0.1584	0.1287
M*	-0.0041	-0.0324	0.3339	0.0477	-0.1395	-1.0996	-0.1129	0.0765	0.0125	-0.4380
CASE	73	6 KT	-3 M/S	SEA LEVEL	3629 KG	MID CG				
	PHI	THETA	PSI	ALPHA	BETA	GAMMA	ΘMR	B1S	A1S	ΘTR
	-0.95	-1.26	0.00	88.74	-0.95	-90.00	14.23	-1.19	-1.43	7.20
	XDOT	ZDOT	UO	VO	WO	VT0				
	0.00	3.05	0.07	-0.05	3.05	3.05				
	U	W	Q	V	P	R	DC	DB	DA	DP
X	-0.0215	-0.0076	0.3198	-0.0258	-0.5359	-0.0528	-0.0300	0.1594	0.0071	0.0090
Z	-0.0979	-0.3400	-0.0978	-0.0945	-0.0136	0.5952	-1.5353	0.0116	-0.0036	-0.0137
M	0.0058	-0.0106	-0.2886	0.0036	0.2190	-0.0012	-0.0012	-0.0642	-0.0037	-0.0086
Y	0.0251	0.0003	-0.4568	-0.0473	-0.3372	0.2473	-0.0360	0.0075	0.1101	0.1891
L*	0.0335	-0.0079	-0.8815	-0.0231	-0.7299	0.0440	0.0128	0.0141	0.2103	0.1489
M*	-0.0097	-0.0196	-0.0031	0.0490	-0.2962	-0.4414	0.2134	0.0005	0.0154	-0.2953

TABLE IV-3 CONTINUED
 AH-IG STABILITY AND CONTROL DERIVATIVES -- SI UNITS
 (BODY-FIXED FRL AXIS SYSTEM)

CASE 74	12 KT		-6 M/S		SEA LEVEL	3629 KG	MID CG			
	PHI	THETA	PSI	ALPHA	BETA	GAMMA	ΘMR	B1S	A1S	ΘTR
	-0.79	-1.72	0.00	88.28	-0.79	-90.00	13.66	-1.65	-1.26	6.02
	XDOT	ZDOT	UO	VO	WO	VT0				
	0.00	6.10	0.18	-0.08	6.09	6.10				
	U	W	Q	V	P	R	DC	DB	DA	DP
X	-0.0247	-0.0090	0.3300	-0.0313	-0.5606	-0.0581	-0.0474	0.1528	0.0048	0.0023
Z	-0.1162	-0.3045	-0.0645	-0.0930	0.0194	0.5778	-1.5225	0.0199	-0.0008	-0.0053
M	0.0110	-0.0110	-0.3153	0.0039	0.2247	0.0058	0.0055	-0.0605	-0.0019	-0.0067
Y	0.0249	0.0038	-0.4594	-0.0507	-0.3747	0.2296	-0.0374	-0.0007	0.1027	0.1641
L'	0.0360	-0.0049	-0.8746	-0.0233	-0.7830	0.0058	0.0033	-0.0015	0.1965	0.1123
M'	-0.0064	-0.0234	0.0524	0.0485	-0.2591	-0.4901	0.1955	-0.0010	0.0142	-0.2831

CASE 75	6 KT		3 M/S		SEA LEVEL	3629 KG	MID CG			
	PHI	THETA	PSI	ALPHA	BETA	GAMMA	ΘMR	B1S	A1S	ΘTR
	-1.35	0.11	0.00	-89.89	1.35	90.00	15.51	-0.04	-1.98	9.28
	XDOT	ZDOT	UO	VO	WO	VT0				
	0.00	-3.05	0.01	0.07	-3.05	3.05				
	U	W	Q	V	P	R	DC	DB	DA	DP
X	-0.0170	-0.0038	0.1865	-0.0216	-0.5419	-0.0164	0.0007	0.1593	0.0031	-0.0027
Z	-0.0670	-0.4134	-0.1327	-0.0912	-0.0675	0.6774	-1.5373	0.0188	0.0017	0.0042
M	0.0024	-0.0202	-0.2564	0.0024	0.2147	0.0002	-0.0080	-0.0615	-0.0006	0.0128
Y	0.0136	-0.0207	-0.6276	-0.0623	-0.2601	0.2447	-0.0726	-0.0129	0.1002	0.1623
L'	0.0266	-0.0263	-1.1304	-0.0295	-0.6413	-0.0183	-0.0397	-0.0272	0.1894	0.0768
M'	0.0025	0.0166	0.0139	0.0581	-0.4224	-0.5632	0.2572	-0.0031	0.0134	-0.3258

CASE 76	12 KT		6 M/S		SEA LEVEL	3629 KG	MID CG			
	PHI	THETA	PSI	ALPHA	BETA	GAMMA	ΘMR	B1S	A1S	ΘTR
	-1.56	1.40	0.00	-88.60	1.56	90.00	16.26	1.04	-2.23	10.17
	XDOT	ZDOT	UO	VO	WO	VT0				
	0.00	-6.10	0.15	0.17	-6.09	6.10				
	U	W	Q	V	P	R	DC	DB	DA	DP
X	-0.0211	0.0035	0.1207	-0.0231	-0.5307	-0.0408	0.0364	0.1669	0.0045	0.0008
Z	-0.0555	-0.4638	-0.1668	-0.0939	-0.1505	0.7208	-1.5588	0.0172	0.0008	0.0005
M	0.0013	-0.0322	-0.2790	-0.0002	0.1963	-0.0084	-0.0219	-0.0655	-0.0021	0.0142
Y	0.0124	-0.0249	-0.6200	-0.0710	-0.1637	0.3000	-0.0713	-0.0025	0.1100	0.1908
L'	0.0262	-0.0286	-1.1700	-0.0296	-0.4663	0.0514	-0.0234	-0.0063	0.2088	0.1277
M'	0.0047	0.0294	-0.1422	0.0641	-0.4474	-0.6107	0.2919	-0.0003	0.0153	-0.3296

TABLE IV-3 CONTINUED
 AH-IG STABILITY AND CONTROL DERIVATIVES -- SI UNITS
 (BODY-FIXED FRL AXIS SYSTEM)

CASE 77	60 KT			6 M/S			SEA LEVEL	3629 KG	MID CG	
	PHI	THETA	PSI	ALPHA	BETA	GAMMA	ØMR	B1S	A1S	ØTR
	-1.21	-1.04	0.00	-12.42	0.26	11.39	14.78	2.04	-2.36	5.04
	XDOT		ZDOT	U0	V0	W0	VT0			
	30.26		-6.10	30.14	0.14	-6.64	30.87			
	U	W	Q	V	P	R	DC	DB	DA	DP
X	-0.0288	-0.0168	0.2743	-0.0039	-0.4842	-0.0443	-0.0395	0.1617	0.0030	-0.0084
Z	-0.0801	-0.8255	-0.4093	-0.0383	-0.4662	0.6979	-1.8102	0.3566	0.0139	-0.0009
H	0.0078	-0.0174	-0.2421	-0.0005	0.1762	0.0271	0.0005	-0.0658	-0.0015	0.0129
Y	0.0019	-0.0144	-0.4824	-0.1028	-0.3847	0.4421	-0.0346	0.0084	0.1095	0.2053
L'	-0.0097	-0.0172	-0.8093	-0.0365	-0.8628	0.0614	0.0215	0.0144	0.2066	0.1366
M'	-0.0184	0.0072	0.1767	0.0418	-0.4515	-0.9663	0.2267	-0.0012	0.0113	-0.3614

CASE 78	60 KT			3 M/S			SEA LEVEL	3629 KG	MID CG	
	PHI	THETA	PSI	ALPHA	BETA	GAMMA	ØMR	B1S	A1S	ØTR
	-0.94	-1.73	0.00	-7.40	0.12	5.67	13.62	1.33	-1.96	3.66
	XDOT		ZDOT	U0	V0	W0	VT0			
	30.72		-3.05	30.61	0.06	-3.98	30.87			
	U	W	Q	V	P	R	DC	DB	DA	DP
X	-0.0280	-0.0237	0.4042	-0.0044	-0.4834	-0.0326	-0.0614	0.1604	0.0027	-0.0068
Z	-0.0940	-0.8305	-0.4206	-0.0315	-0.4538	0.6115	-1.8041	0.3590	0.0114	-0.0052
H	0.0073	-0.0124	-0.2838	-0.0001	0.1793	0.0234	0.0060	-0.0641	-0.0014	0.0088
Y	0.0009	-0.0083	-0.4573	-0.1011	-0.5056	0.4172	-0.0207	0.0065	0.1053	0.2067
L'	-0.0104	-0.0159	-0.7398	-0.0267	-1.0780	0.0441	0.0257	0.0142	0.1994	0.1355
M'	-0.0169	-0.0118	0.2435	0.0453	-0.4142	-0.9314	0.1692	0.0070	0.0108	-0.3653

CASE 79	60 KT			-3 M/S			SEA LEVEL	3629 KG	MID CG	
	PHI	THETA	PSI	ALPHA	BETA	GAMMA	ØMR	B1S	A1S	ØTR
	-0.46	-2.68	0.00	2.98	-0.02	-5.67	11.21	0.07	-1.14	1.24
	XDOT		ZDOT	U0	V0	W0	VT0			
	30.72		3.05	30.83	-0.01	1.61	30.87			
	U	W	Q	V	P	R	DC	DB	DA	DP
X	-0.0260	-0.0300	0.6492	-0.0044	-0.4782	-0.0154	-0.0902	0.1569	0.0027	-0.0067
Z	-0.1176	-0.8387	-0.4436	-0.0182	-0.4032	0.4426	-1.7805	0.3553	0.0098	-0.0050
H	0.0055	-0.0096	-0.3688	-0.0003	0.1836	0.0167	0.0133	-0.0608	-0.0014	0.0046
Y	-0.0003	0.0055	-0.4239	-0.1056	-0.7327	0.3734	0.0098	0.0005	0.0968	0.2036
L'	-0.0104	-0.0050	-0.6538	-0.0015	-1.4710	0.0172	0.0414	0.0093	0.1854	0.1183
M'	-0.0141	-0.0422	0.3274	0.0470	-0.3081	-0.8757	0.0674	0.0211	0.0114	-0.3802

TABLE IV-3 CONTINUED
 AH-IG STABILITY AND CONTROL DERIVATIVES -- SI UNITS
 (BODY-FIXED FRL AXIS SYSTEM)

CASE 80	60 KT			-6 M/S			SEA LEVEL			3629 KG	MID CG	
	PHI	THETA	PSI	ALPHA	BETA	GAMMA	ΘMR	B1S	A1S	ΘTR		
	-0.25	-3.13	0.00	8.27	-0.04	-11.39	9.96	-0.70	-0.75	0.24		
	XDOT		ZDOT	U0	V0	W0	VT0					
	30.26		6.10	30.55	-0.02	4.44	30.87					
	U	W	Q	V	P	R	DC	DB	DA	DP		
X	-0.0253	-0.0331	0.7384	-0.0041	-0.4851	-0.0124	-0.1078	0.1533	0.0019	-0.0033		
Z	-0.1298	-0.8280	-0.5030	-0.0127	-0.3445	0.3536	-1.7612	0.3412	0.0087	-0.0088		
H	0.0043	-0.0082	-0.3987	-0.0007	0.1904	0.0161	0.0187	-0.0584	-0.0009	0.0024		
Y	-0.0009	0.0115	-0.4009	-0.1127	-0.8263	0.3538	0.0232	-0.0015	0.0931	0.2115		
L'	-0.0102	-0.0005	-0.5895	0.0157	-1.6257	0.0040	0.0511	0.0076	0.1790	0.1256		
M'	-0.0128	-0.0569	0.3971	0.0468	-0.2420	-0.8574	0.0205	0.0290	0.0115	-0.3866		

CASE 81	1 KT			LEVEL FLIGHT			3048 M	3629 KG	MID CG	
	PHI	THETA	PSI	ALPHA	BETA	GAMMA	ΘMR	B1S	A1S	ΘTR
	-1.35	-0.60	0.00	-0.60	0.01	0.00	16.64	-0.63	-2.06	11.76
	XDOT		ZDOT	U0	V0	W0	VT0			
	0.51		0.00	0.51	0.00	-0.01	0.51			
	U	W	Q	V	P	R	DC	DB	DA	DP
X	-0.0197	-0.0145	0.2069	-0.0295	-0.5744	-0.0318	-0.0219	0.1526	-0.0015	-0.0167
Z	-0.0843	-0.2894	0.0096	-0.0681	-0.0251	0.6354	-1.2086	0.0179	-0.0020	-0.0083
H	0.0040	-0.0118	-0.2759	0.0045	0.2324	0.0041	0.0016	-0.0591	0.0012	0.0125
Y	0.0199	-0.0038	-0.4806	-0.0521	-0.4206	0.1926	-0.0576	-0.0098	0.1017	0.1328
L'	0.0354	-0.0148	-1.0302	-0.0341	-0.9499	-0.0361	-0.0169	-0.0179	0.1942	0.0745
M'	-0.0004	-0.0101	-0.1093	0.0435	-0.4646	-0.4977	0.2372	-0.0034	0.0130	-0.2611

CASE 82	60 KT			LEVEL FLIGHT			3048 M	3629 KG	MID CG	
	PHI	THETA	PSI	ALPHA	BETA	GAMMA	ΘMR	B1S	A1S	ΘTR
	-0.76	-2.06	0.00	-2.06	0.03	0.00	14.02	1.15	-1.98	4.00
	XDOT		ZDOT	U0	V0	W0	VT0			
	30.87		0.00	30.85	0.01	-1.11	30.87			
	U	W	Q	V	P	R	DC	DB	DA	DP
X	-0.0272	-0.0242	0.6272	-0.0054	-0.4571	-0.0247	-0.0744	0.1587	0.0017	-0.0093
Z	-0.0971	-0.6037	-0.5072	-0.0233	-0.3143	0.5297	-1.3198	0.2594	0.0074	-0.0108
H	0.0072	-0.0065	-0.3424	0.0008	0.1722	0.0135	0.0158	-0.0634	-0.0009	0.0078
Y	-0.0010	0.0027	-0.4259	-0.0815	-0.7077	0.3137	-0.0052	0.0009	0.1019	0.1563
L'	-0.0119	0.0003	-0.6311	-0.0228	-1.4781	-0.0261	0.0489	0.0058	0.1941	0.1062
M'	-0.0146	-0.0140	0.4013	0.0335	-0.4491	-0.7188	0.1563	0.0077	0.0114	-0.2715

TABLE IV-3 CONTINUED
 AH-IG STABILITY AND CONTROL DERIVATIVES -- SI UNITS
 (BODY-FIXED FRL AXIS SYSTEM)

CASE	83		100 KT	LEVEL FLIGHT	3048 M	3629 KG	MID CG			
	PHI	THETA	PSI	ALPHA	BETA	GAMMA	ΘMR	B1S	A1S	ΘTR
	-0.98	-2.95	0.00	-2.95	0.05	0.00	14.36	3.43	-1.59	3.34
	XDOT	ZDOT	UO	VO	WO	VT0				
	51.44	0.00	51.38	0.05	-2.65	51.44				
	U	W	Q	V	P	R	DC	DB	DA	DP
X	-0.0319	-0.0206	0.5944	-0.0016	-0.4574	-0.0286	-0.0795	0.1587	0.0013	-0.0147
Z	-0.0480	-0.7030	-1.0552	-0.0186	-0.5019	0.5696	-1.5098	0.4825	0.0158	-0.0078
H	0.0083	-0.0119	-0.3795	-0.0019	0.1658	0.0309	0.0136	-0.0673	-0.0007	0.0147
Y	0.0024	-0.0044	-0.4430	-0.1129	-0.5856	0.3891	-0.0138	0.0064	0.1018	0.1739
L'	-0.0041	-0.0068	-0.7019	-0.0161	-1.2254	-0.0109	0.0366	0.0175	0.1948	0.1101
M'	-0.0082	-0.0025	0.2559	0.0356	-0.3518	-0.9469	0.1660	0.0139	0.0129	-0.3112

CASE	84		12 KT	6 M/S	3048 M	3629 KG	MID CG			
	PHI	THETA	PSI	ALPHA	BETA	GAMMA	ΘMR	B1S	A1S	ΘTR
	-1.79	1.61	0.00	-88.39	1.79	90.00	18.06	1.23	-2.46	14.25
	XDOT	ZDOT	UO	VO	WO	VT0				
	0.00	-6.10	0.17	0.19	-6.09	6.10				
	U	W	Q	V	P	R	DC	DB	DA	DP
X	-0.0244	-0.0033	0.2284	-0.0246	-0.5473	-0.0305	-0.0338	0.1690	0.0043	-0.0145
Z	-0.0381	-0.3540	-0.0896	-0.0720	-0.0865	0.6973	-1.2147	0.0169	0.0005	0.0077
H	0.0049	-0.0304	-0.3198	0.0012	0.2091	-0.0367	-0.0208	-0.0680	-0.0031	0.0172
Y	0.0159	-0.0175	-0.5582	-0.0628	-0.2196	0.2483	-0.0485	0.0128	0.1214	0.1503
L'	0.0338	-0.0185	-1.0833	-0.0340	-0.6154	0.0764	0.0206	0.0230	0.2303	0.1513
M'	0.0066	0.0220	-0.2223	0.0511	-0.5543	-0.4923	0.2968	-0.0017	0.0149	-0.1866

CASE	85		60 KT	9 M/S	3048 M	3629 KG	MID CG			
	PHI	THETA	PSI	ALPHA	BETA	GAMMA	ΘMR	B1S	A1S	ΘTR
	-1.68	1.20	0.00	-14.84	0.43	16.05	17.31	4.46	-3.14	15.61
	XDOT	ZDOT	UO	VO	WO	VT0				
	29.66	-8.53	29.84	0.23	-7.91	30.87				
	U	W	Q	V	P	R	DC	DB	DA	DP
X	-0.0251	0.0048	0.3165	-0.0066	-0.5095	-0.1072	0.0093	0.1610	0.0020	-0.0129
Z	-0.0507	-0.5805	-0.5959	-0.0381	-0.3356	0.7015	-1.2994	0.2545	0.0115	-0.0020
H	0.0075	-0.0238	-0.2683	0.0003	0.2257	0.0584	-0.0124	-0.0675	-0.0011	0.0255
Y	-0.0041	-0.0091	-0.4987	-0.0720	-0.2942	0.2892	-0.0327	0.0084	0.1111	0.1049
L'	-0.0123	-0.0039	-0.9597	-0.0383	-0.8144	0.0907	0.0469	0.0100	0.2125	0.0886
M'	-0.0048	0.0238	-0.1614	0.0013	-0.6544	-0.7096	0.2917	-0.0111	0.0106	-0.1563

TABLE IV-3 CONTINUED
 AH-IG STABILITY AND CONTROL DERIVATIVES -- SI UNITS
 (BODY-FIXED FRL AXIS SYSTEM)

CASE	86	60 KT	-8 M/S	3048 M	3629 KG	MID CG				
	PHI	THETA	PSI	ALPHA	BETA	GAMMA	ΘMR	B1S	A1S	ΘTR
	-0.12	-3.05	0.00	12.88	-0.03	-15.93	10.67	-0.63	-0.92	-0.17
	XDOT	ZDOT	U0	V0	W0	VT0				
	29.68	8.47	30.09	-0.01	6.98	30.87				
	U	W	Q	V	P	R	DC	DB	DA	DP
X	-0.0243	-0.0527	0.8905	-0.0059	-0.4583	-0.0041	-0.0991	0.1540	0.0030	-0.0015
Z	-0.1226	-0.5194	-0.5896	-0.0102	-0.1634	0.3934	-1.2591	0.2298	0.0082	-0.0050
H	0.0048	-0.0079	-0.4325	-0.0000	0.1845	0.0141	0.0214	-0.0597	-0.0013	0.0012
Y	-0.0028	0.0115	-0.3871	-0.0951	-0.9727	0.2487	0.0215	-0.0018	0.0947	0.1639
L'	-0.0123	0.0057	-0.5245	0.0158	-1.9330	-0.0269	0.0590	0.0051	0.1829	0.1047
H'	-0.0117	-0.0426	0.5228	0.0338	-0.3072	-0.6504	0.0516	0.0228	0.0126	-0.2887
CASE	87	100 KT	-9 M/S	3048 M	3629 KG	MID CG				
	PHI	THETA	PSI	ALPHA	BETA	GAMMA	ΘMR	B1S	A1S	ΘTR
	-0.30	-4.19	0.00	6.05	-0.03	-10.24	10.42	0.88	-0.35	-0.43
	XDOT	ZDOT	U0	V0	W0	VT0				
	50.63	9.14	51.16	-0.03	5.42	51.44				
	U	W	Q	V	P	R	DC	DB	DA	DP
X	-0.0292	-0.0308	0.9377	-0.0021	-0.4558	0.0129	-0.1211	0.1541	0.0009	-0.0015
Z	-0.0729	-0.7008	-1.1358	-0.0029	-0.4121	0.3629	-1.5115	0.4630	0.0124	-0.0182
H	0.0056	-0.0076	-0.5121	-0.0014	0.1794	0.0070	0.0272	-0.0608	-0.0006	-0.0014
Y	0.0008	0.0096	-0.3993	-0.1208	-0.9338	0.3426	0.0181	-0.0050	0.0894	0.1800
L'	-0.0043	-0.0034	-0.9066	0.0177	-1.8538	-0.0352	0.0329	0.0089	0.1735	0.1102
H'	-0.0040	-0.0533	-0.5208	0.0340	-0.2471	-0.8685	-0.0034	0.0491	0.0128	-0.3262
CASE	88	1 KT	LEVEL FLIGHT AT SEA LEVEL	3629 KG	PWD CG					
	PHI	THETA	PSI	ALPHA	BETA	GAMMA	ΘMR	B1S	A1S	ΘTR
	-1.10	-4.24	0.00	-4.24	0.08	0.00	14.81	-3.95	-1.75	8.35
	XDOT	ZDOT	U0	V0	W0	VT0				
	0.51	0.00	0.51	0.00	-0.04	0.51				
	U	W	Q	V	P	R	DC	DB	DA	DP
X	-0.0260	-0.0363	0.1198	-0.0332	-0.5495	0.0407	-0.1194	0.1544	0.0044	0.0003
Z	-0.1587	-0.3712	0.0164	-0.0900	0.0229	0.6286	-1.5300	0.0223	-0.0009	-0.0042
H	0.0010	-0.0121	-0.2371	0.0017	0.2227	-0.0004	-0.0023	-0.0608	-0.0020	0.0026
Y	0.0170	-0.0042	-0.4622	-0.0539	-0.3058	0.2559	-0.0535	-0.0002	0.1061	0.1817
L'	0.0276	-0.0178	-0.7764	-0.0259	-0.7091	0.0209	-0.0096	0.0094	0.2008	0.1209
H'	-0.0042	-0.0148	0.4799	0.0532	-0.3826	-0.5378	0.2335	-0.0022	0.0110	-0.3200

TABLE IV-3 CONTINUED
 AH-IG STABILITY AND CONTROL DERIVATIVES -- SI UNITS
 (BODY-FIXED FRL AXIS SYSTEM)

CASE	60 KT		LEVEL FLIGHT AT SEA LEVEL				3629 KG	FWD CG		
	PHI	THETA	PSI	ALPHA	BETA	GAMMA	ΘMR	B1S	A1S	ΘTR
	-0.65	-5.41	0.00	-5.41	0.06	0.00	12.47	-2.29	-1.50	2.31
	XDOT	ZDOT	U0	V0	W0	VT0				
	30.87	0.00	30.73	0.03	-2.91	30.87				
	U	W	Q	V	P	R	DC	DB	DA	DP
X	-0.0361	-0.0733	0.4329	-0.0058	-0.5109	0.0162	-0.1828	0.1761	0.0045	-0.0060
Z	-0.1438	-0.8313	-0.6008	-0.0228	-0.3655	0.5532	-1.7932	0.3469	0.0128	-0.0037
H	0.0064	-0.0134	-0.3108	-0.0000	0.1854	0.0197	0.0077	-0.0582	-0.0017	0.0067
Y	0.0001	-0.0027	-0.4333	-0.1002	-0.6262	0.4114	-0.0047	0.0035	0.1021	0.2052
L'	-0.0115	-0.0087	-0.4516	-0.0191	-1.2817	0.0264	0.0383	0.0141	0.1936	0.1288
M'	-0.0178	-0.0287	0.8603	0.0501	-0.3357	-0.9392	0.1203	0.0170	0.0090	-0.3737

CASE	100 KT		LEVEL FLIGHT AT SEA LEVEL				3629 KG	FWD CG		
	PHI	THETA	PSI	ALPHA	BETA	GAMMA	ΘMR	B1S	A1S	ΘTR
	-0.94	-5.94	0.00	-5.94	0.10	0.00	13.15	0.54	-1.22	1.94
	XDOT	ZDOT	U0	V0	W0	VT0				
	51.44	0.00	51.17	0.09	-5.32	51.44				
	U	W	Q	V	P	R	DC	DB	DA	DP
X	-0.0399	-0.0657	0.3874	-0.0034	-0.5206	-0.0070	-0.1811	0.1816	0.0015	-0.0174
Z	-0.0873	-0.9866	-1.2603	-0.0203	-0.7307	0.5894	-2.1078	0.6423	0.0191	-0.0278
H	0.0091	-0.0269	-0.3815	-0.0023	0.1741	0.0414	-0.0063	-0.0551	-0.0006	0.0128
Y	0.0028	-0.0102	-0.4328	-0.1426	-0.5301	0.5674	-0.0148	0.0156	0.1077	0.2428
L'	-0.0057	-0.0227	-0.5079	-0.0130	-1.0940	0.0482	0.0190	0.0408	0.2045	0.1628
M'	-0.0122	-0.0257	0.6521	0.0533	-0.2990	-1.2517	0.1145	0.0248	0.0085	-0.4289

CASE	1 KT		LEVEL FLIGHT AT SEA LEVEL				3629 KG	AFT CG		
	PHI	THETA	PSI	ALPHA	BETA	GAMMA	ΘMR	B1S	A1S	ΘTR
	-1.19	3.43	0.00	3.43	-0.07	0.00	14.82	3.07	-1.75	8.44
	XDOT	ZDOT	U0	V0	W0	VT0				
	0.51	0.00	0.51	-0.00	0.03	0.51				
	U	W	Q	V	P	R	DC	DB	DA	DP
X	-0.0100	0.0107	0.1447	-0.0158	-0.5302	-0.0756	0.0937	0.1625	0.0036	-0.0009
Z	-0.0756	-0.3717	-0.0249	-0.0948	-0.1174	0.6274	-1.5304	0.0215	0.0001	-0.0074
H	0.0013	-0.0102	-0.2542	0.0029	0.2168	0.0093	-0.0016	-0.0645	-0.0016	0.0034
Y	0.0199	-0.0033	-0.4540	-0.0542	-0.3095	0.2412	-0.0503	-0.0009	0.1059	0.1814
L'	0.0328	-0.0166	-1.2631	-0.0267	-0.7122	0.0152	-0.0105	-0.0044	0.2031	0.1245
M'	-0.0029	-0.0153	-0.8258	0.0502	-0.3787	-0.5093	0.2288	-0.0009	0.0178	-0.3088

TABLE IV-3 CONTINUED
 AH-IG STABILITY AND CONTROL DERIVATIVES -- SI UNITS
 (BODY-FIXED FRL AXIS SYSTEM)

CASE	60 KT		LEVEL FLIGHT AT SEA LEVEL				3629 KG	AFT CG		
	PHI	THETA	PSI	ALPHA	BETA	GAMMA	ΘMR	B1S	A1S	ΘTR
	-0.74	1.35	0.00	1.35	-0.02	0.00	12.37	4.20	-1.58	2.47
		XDOT	ZDOT	U0	V0	W0	VTO			
		30.87	0.00	30.86	-0.01	0.72	30.87			
	U	W	Q	V	P	R	DC	DB	DA	DP
X	-0.0223	0.0239	0.6046	-0.0029	-0.4534	-0.0659	0.0435	0.1373	0.0018	-0.0066
Z	-0.0612	-0.8430	-0.2223	-0.0264	-0.5024	0.4910	-1.7909	0.3754	0.0111	-0.0065
N	0.0058	-0.0057	-0.3416	-0.0000	0.1846	0.0208	0.0141	-0.0674	-0.0011	0.0062
Y	0.0007	-0.0010	-0.4248	-0.1049	-0.6155	0.3783	-0.0040	0.0049	0.1013	0.2078
L'	-0.0089	-0.0113	-0.9038	-0.0093	-1.2649	0.0400	0.0363	0.0132	0.1949	0.1338
M'	-0.0127	-0.0274	-0.3376	0.0432	-0.3647	-0.8571	0.1188	0.0160	0.0161	-0.3650

CASE	100 KT		LEVEL FLIGHT AT SEA LEVEL				3629 KG	AFT CG		
	PHI	THETA	PSI	ALPHA	BETA	GAMMA	ΘMR	B1S	A1S	ΘTR
	-1.07	-0.49	0.00	-0.49	0.01	0.00	13.00	5.99	-1.38	2.16
		XDOT	ZDOT	U0	V0	W0	VTO			
		51.44	0.00	51.44	0.01	-0.44	51.44			
	U	W	Q	V	P	R	DC	DB	DA	DP
X	-0.0350	0.0314	0.5830	-0.0004	-0.4126	-0.0612	0.0565	0.1147	0.0018	-0.0122
Z	-0.0103	-0.9939	-0.5691	-0.0232	-0.8249	0.5293	-2.1038	0.7097	0.0197	0.0061
N	0.0067	-0.0102	-0.3890	-0.0023	0.1727	0.0291	0.0133	-0.0763	-0.0011	0.0125
Y	0.0043	-0.0138	-0.4355	-0.1483	-0.5110	0.5113	-0.0242	0.0133	0.0985	0.2305
L'	-0.0023	-0.0299	-0.9355	-0.0012	-1.0694	0.0450	-0.0044	0.0308	0.1903	0.1387
M'	-0.0083	-0.0209	-0.4001	0.0437	-0.3316	-1.1324	0.1095	0.0239	0.0163	-0.4168

CASE	1 KT		LEVEL FLIGHT AT SEA LEVEL				2948 KG	MID CG		
	PHI	THETA	PSI	ALPHA	BETA	GAMMA	ΘMR	B1S	A1S	ΘTR
	-1.15	-0.82	0.00	-0.92	0.02	0.00	13.79	-0.83	-1.56	6.85
		XDOT	ZDOT	U0	V0	W0	VTO			
		0.51	0.00	0.51	0.00	-0.01	0.51			
	U	W	Q	V	P	R	DC	DB	DA	DP
X	-0.0147	-0.0158	0.0664	-0.0277	-0.6082	-0.0104	-0.0284	0.1563	0.0035	0.0010
Z	-0.1529	-0.4397	0.0021	-0.1140	-0.0605	0.6235	-1.8039	0.0212	-0.0001	-0.0030
N	-0.0004	-0.0104	-0.1985	-0.0005	0.2075	0.0049	-0.0016	-0.0519	-0.0013	0.0027
Y	0.0174	-0.0038	-0.5219	-0.0574	-0.2389	0.2808	-0.0540	-0.0005	0.1048	0.2012
L'	0.0243	-0.0197	-1.0956	-0.0136	-0.5865	-0.0279	0.0031	-0.0014	0.1907	0.0816
M'	-0.0045	-0.0161	-0.1075	0.0543	-0.1731	-0.5206	0.2164	-0.0009	0.0156	-0.3305

TABLE IV-3 CONTINUED
 AH-IG STABILITY AND CONTROL DERIVATIVES -- SI UNITS
 (BODY-FIXED FRL AXIS SYSTEM)

CASE	60 KT		LEVEL FLIGHT AT SEA LEVEL				2948 KG	MID CG		
	PHI	THETA	PSI	ALPHA	BETA	GAMMA	ΘMR	B1S	A1S	ΘTR
	-0.77	-2.52	0.00	-2.52	0.03	0.00	11.59	0.46	-1.32	1.86
	XDOT		ZDOT	U0	V0	W0	VT0			
	30.87		0.00	30.84	0.02	-1.36	30.87			
	U	W	Q	V	P	R	DC	DB	DA	DP
X	-0.0284	-0.0302	0.5240	-0.0043	-0.5618	-0.0180	-0.0789	0.1580	0.0027	-0.0056
Z	-0.1126	-1.0366	-0.5619	-0.0261	-0.5089	0.5379	-2.2134	0.4465	0.0126	-0.0064
N	0.0051	-0.0127	-0.2994	-0.0006	0.1779	0.0182	0.0028	-0.0511	-0.0010	0.0057
Y	0.0014	-0.0026	-0.5163	-0.1213	-0.6071	0.5025	-0.0066	0.0043	0.1013	0.2464
L*	-0.0101	-0.0158	-0.7834	0.0066	-1.2169	-0.0371	0.0354	0.0138	0.1841	0.0931
M*	-0.0140	-0.0275	0.2231	0.0553	-0.3595	-1.0001	0.1025	0.0150	0.0137	-0.4171

CASE	100 KT		LEVEL FLIGHT AT SEA LEVEL				2948 KG	MID CG		
	PHI	THETA	PSI	ALPHA	BETA	GAMMA	ΘMR	B1S	A1S	ΘTR
	-1.21	-3.85	0.00	-3.85	0.08	0.00	12.50	3.02	-1.24	1.74
	XDOT		ZDOT	U0	V0	W0	VT0			
	51.44		0.00	51.33	0.07	-3.46	51.44			
	U	W	Q	V	P	R	DC	DB	DA	DP
X	-0.0396	-0.0112	0.4763	-0.0023	-0.5239	-0.0314	-0.0435	0.1448	0.0002	-0.0159
Z	-0.0496	-1.2222	-1.0935	-0.0256	-0.9322	0.5971	-2.5974	0.8481	0.0179	-0.0016
N	0.0074	-0.0260	-0.3583	-0.0025	0.1610	0.0348	-0.0134	-0.0509	0.0002	0.0143
Y	0.0044	-0.0172	-0.5319	-0.1745	-0.4697	0.6679	-0.0334	0.0122	0.0989	0.2673
L*	-0.0046	-0.0332	-0.9128	0.0200	-0.9891	-0.0824	-0.0038	0.0279	0.1801	0.0801
M*	-0.0088	-0.0166	-0.0462	0.0584	-0.3602	-1.3244	0.1190	0.0172	0.0139	-0.4778

CASE	1 KT		LEVEL FLIGHT AT SEA LEVEL				2948 KG	FWD CG		
	PHI	THETA	PSI	ALPHA	BETA	GAMMA	ΘMR	B1S	A1S	ΘTR
	-1.10	-5.18	0.00	-5.18	0.10	0.00	13.76	-4.90	-1.55	6.79
	XDOT		ZDOT	U0	V0	W0	VT0			
	0.51		0.00	0.51	0.00	-0.05	0.51			
	U	W	Q	V	P	R	DC	DB	DA	DP
X	-0.0318	-0.0478	0.0603	-0.0358	-0.6148	0.0524	-0.1719	0.1529	0.0039	0.0016
Z	-0.2094	-0.4373	0.0394	-0.1106	0.0296	0.6213	-1.8007	0.0242	0.0000	-0.0016
N	-0.0006	-0.0112	-0.1919	-0.0007	0.2114	0.0905	-0.0014	-0.0505	-0.0014	0.0025
Y	0.0157	-0.0042	-0.5273	-0.0572	-0.2425	0.2659	-0.0557	-0.0002	0.1045	0.2006
L*	0.0213	-0.0199	-0.6922	-0.0128	-0.5956	-0.0299	0.0044	0.0007	0.1886	0.0801
M*	-0.0051	-0.0157	0.7407	0.0556	-0.1759	-0.5360	0.2203	-0.0018	0.0124	-0.3162

TABLE IV-3 CONTINUED
 AH-IG STABILITY AND CONTROL DERIVATIVES -- SI UNITS
 (BODY-FIXED FRL AXIS SYSTEM)

CASE	98	60 KT	LEVEL FLIGHT AT SEA LEVEL			2948 KG	FWD CG			
	PHI	THETA	PSI	ALPHA	BETA	GAMMA	ΘMR	B1S	A1S	ΘTR
	-0.72	-6.38	0.00	-6.38	0.08	0.00	11.64	-3.26	-1.27	1.78
	XDOT	ZDOT	U0	V0	W0	VT0				
	30.87	0.00	30.68	0.04	-3.43	30.87				
	U	W	Q	V	P	R	DC	DB	DA	DP
X	-0.0418	-0.0984	0.3980	-0.0058	-0.5929	0.0290	-0.2374	0.1856	0.0039	-0.0077
Z	-0.1714	-1.0271	-0.8161	-0.0237	-0.4115	0.5619	-2.2096	0.4294	0.0132	-0.0013
H	0.0050	-0.0175	-0.2891	-0.0006	0.1788	0.0181	-0.0011	-0.0462	-0.0012	0.0066
Y	0.0005	-0.0029	-0.5224	-0.1190	-0.6168	0.5214	-0.0073	0.0028	0.1008	0.2396
L'	-0.0125	-0.0137	-0.4275	0.0001	-1.2321	-0.0611	0.0358	0.0127	0.1809	0.0783
N'	-0.0166	-0.0272	0.9923	0.0583	-0.3435	-1.0569	0.1039	0.0151	0.0091	-0.4270

CASE	99	28 KT	14 M/S	SEA LEVEL		2948 KG	FWD CG			
	PHI	THETA	PSI	ALPHA	BETA	GAMMA	ΘMR	B1S	A1S	ΘTR
	-2.30	4.79	0.00	-85.21	2.29	90.00	17.69	3.40	-2.88	10.88
	XDOT	ZDOT	U0	V0	W0	VT0				
	0.00	-14.46	1.21	0.58	-14.40	14.46				
	U	W	Q	V	P	R	DC	DB	DA	DP
X	-0.0413	0.0283	-0.2726	-0.0019	-0.5927	-0.0916	0.1385	0.1899	0.0036	-0.0006
Z	-0.0441	-0.7525	-0.3760	-0.1037	-0.2983	0.9863	-1.9898	0.0326	0.0097	0.0140
H	-0.0155	-0.0927	-0.3153	-0.0022	0.1687	0.0058	-0.1026	-0.0599	-0.0013	0.0335
Y	0.0056	-0.0448	-0.7715	-0.1177	0.2163	0.4979	-0.1158	-0.0028	0.1229	0.2362
L'	0.0222	-0.0367	-1.5663	-0.0147	0.1288	0.0435	-0.0201	-0.0099	0.2184	0.0996
N'	0.0104	0.0776	-0.5611	0.0996	-0.5722	-0.8814	0.4043	0.0001	0.0132	-0.3847

CASE	100	60 KT	15 M/S	SEA LEVEL		2948 KG	FWD CG			
	PHI	THETA	PSI	ALPHA	BETA	GAMMA	ΘMR	B1S	A1S	ΘTR
	-2.22	-1.32	0.00	-29.59	1.10	28.29	17.33	2.59	-3.28	8.03
	XDOT	ZDOT	U0	V0	W0	VT0				
	27.18	-14.63	26.84	0.59	-15.24	30.87				
	U	W	Q	V	P	R	DC	DB	DA	DP
X	-0.0114	0.0274	-0.1798	-0.0049	-0.5708	-0.0758	-0.0170	0.1811	0.0034	-0.0129
Z	-0.0454	-1.0120	-0.6682	-0.0649	-0.5506	1.0621	-2.2419	0.3954	0.0260	0.0153
H	0.0091	-0.0844	-0.0932	-0.0012	0.1516	0.0575	-0.0677	-0.0487	0.0000	0.0317
Y	0.0057	-0.0399	-0.6656	-0.1255	0.1211	0.6637	-0.1039	0.0047	0.1189	0.2276
L'	-0.0129	-0.0311	-1.1296	-0.0473	-0.0481	-0.0465	0.0059	-0.0059	0.2093	0.0772
N'	-0.0227	0.0742	0.0433	0.0918	-0.6191	-1.2807	0.4086	-0.0267	0.0095	-0.4061

TABLE IV-3 CONTINUED
 AH-IG STABILITY AND CONTROL DERIVATIVES -- SI UNITS
 (BODY-FIXED FRL AXIS SYSTEM)

CASE 101		30 KT	-15 M/S	SEA LEVEL	2948 KG	FWD CG					
PHI	THETA	PSI	ALPHA	BETA	GAMMA	ΘMR	B1S	A1S	ΘTR		
-0.05	-6.52	0.00	83.48	-0.05	-90.00	9.39	-6.42	-0.29	0.28		
XDOT		ZDOT	U0	V0	W0	VT0					
0.00		15.24	1.73	-0.01	15.14	15.24					
U	W	Q	V	P	R	DC	DB	DA	DP		
X	-0.0340	-0.0794	0.4964	-0.0024	-0.5633	0.0492	-0.1902	0.1379	0.0035	0.0067	
Z	-0.0152	-0.7049	-0.4806	0.0477	0.1248	-0.2666	-1.4979	0.0074	0.0010	-0.0041	
H	0.0003	0.0006	-0.2341	-0.0170	0.1966	-0.0270	0.0029	-0.0465	-0.0012	-0.0065	
Y	0.0216	0.0017	-0.5648	-0.0914	-0.6676	0.5733	-0.0011	0.0028	0.0935	0.1396	
L*	0.0330	-0.0103	-0.4762	0.0021	-1.2141	-0.1852	0.0265	0.0058	0.1711	0.0960	
H*	-0.0045	-0.0290	1.1709	0.0933	-0.1035	-1.1199	0.0611	0.0016	0.0118	-0.2311	

CASE 102		60 KT	-9 M/S	SEA LEVEL	2948 KG	FWD CG					
PHI	THETA	PSI	ALPHA	BETA	GAMMA	ΘMR	B1S	A1S	ΘTR		
-0.10	-8.02	0.00	8.03	-0.01	-16.05	8.10	-6.06	-0.20	-0.50		
XDOT		ZDOT	U0	V0	W0	VT0					
29.66		8.53	30.56	-0.01	4.31	30.87					
U	W	Q	V	P	R	DC	DB	DA	DP		
X	-0.0469	-0.1221	0.7404	-0.0035	-0.5764	0.0312	-0.3248	0.1799	0.0025	-0.0040	
Z	-0.2211	-1.0036	-0.9710	-0.0054	-0.2606	0.2697	-2.1579	0.3887	0.0093	-0.0122	
H	0.0023	-0.0079	-0.3930	-0.0015	0.1871	0.0099	0.0240	-0.0425	-0.0007	0.0018	
Y	0.0009	0.0187	-0.4699	-0.1335	-0.9925	0.4637	0.0379	-0.0053	0.0879	0.2487	
L*	-0.0103	-0.0031	-0.2019	0.0491	-1.8272	-0.0631	0.0416	0.0075	0.1606	0.0786	
H*	-0.0178	-0.0755	1.3448	0.0592	-0.1761	-0.9848	-0.0551	0.0376	0.0100	-0.4395	

CASE 103		1 KT	LEVEL FLIGHT AT SEA LEVEL	2948 KG	AFT CG						
PHI	THETA	PSI	ALPHA	BETA	GAMMA	ΘMR	B1S	A1S	ΘTR		
-1.19	3.59	0.00	3.59	-0.07	0.00	13.79	3.27	-1.56	6.88		
XDOT		ZDOT	U0	V0	W0	VT0					
0.51		0.00	0.51	-0.00	0.03	0.51					
U	W	Q	V	P	R	DC	DB	DA	DP		
X	-0.0069	0.0162	0.0836	-0.0142	-0.5935	-0.0798	0.1152	0.1598	0.0020	-0.0030	
Z	-0.0957	-0.4385	-0.0279	-0.1161	-0.1488	0.6188	-1.8025	0.0204	0.0005	-0.0019	
H	-0.0003	-0.0094	-0.2068	0.0005	0.2055	0.0100	-0.0015	-0.0534	-0.0009	0.0038	
Y	0.0192	-0.0032	-0.5127	-0.0572	-0.2357	0.2789	-0.0497	0.0018	0.1063	0.2065	
L*	0.0276	-0.0186	-1.4450	-0.0135	-0.5757	-0.0143	0.0087	0.0021	0.1958	0.0985	
H*	-0.0038	-0.0162	-0.9536	0.0526	-0.3685	-0.5026	0.2154	0.0002	0.0134	-0.3233	

TABLE IV-3 CONTINUED
 AH-IG STABILITY AND CONTROL DERIVATIVES -- SI UNITS
 (BODY-FIXED FRL AXIS SYSTEM)

CASE 104	60 KT			LEVEL FLIGHT AT SEA LEVEL			2948 KG	AFT CG		
	PHI	THETA	PSI	ALPHA	BETA	GAMMA	ΘMR	B1S	A1S	ΘTR
	-0.84	1.18	0.00	1.18	-0.02	0.00	11.55	4.15	-1.38	1.96
	XDOT	ZDOT		U0	V0	W0	VTO			
	30.87	0.00		30.86	-0.01	0.64	30.87			
	U	W	Q	V	P	R	DC	DB	DA	DP
X	-0.0241	0.0380	0.6129	-0.0023	-0.5162	-0.0608	0.0793	0.1299	0.0016	-0.0072
Z	-0.0532	-1.0420	-0.2907	-0.0281	-0.5883	0.4851	-2.2069	0.4699	0.0116	-0.0004
M	0.0043	-0.0081	-0.3121	-0.0006	0.1770	0.0172	0.0069	-0.0567	-0.0008	0.0063
Y	0.0024	-0.0036	-0.5076	-0.1250	-0.5940	0.4836	-0.0057	0.0066	0.1003	0.2467
L*	-0.0076	-0.0170	-1.1152	0.0143	-1.1960	-0.0179	0.0361	0.0167	0.1845	0.0945
N*	-0.0113	-0.0255	-0.5378	0.0509	-0.3734	-0.9503	0.1031	0.0157	0.0175	-0.4113

CASE 105	60 KT			16 M/S	SEA LEVEL	2948 KG	AFT CG			
	PHI	THETA	PSI	ALPHA	BETA	GAMMA	ΘMR	B1S	A1S	ΘTR
	-2.41	6.33	0.00	-23.83	0.98	30.17	17.28	8.31	-3.32	7.98
	XDOT	ZDOT		U0	V0	W0	VTO			
	26.68	-15.51		28.23	0.53	-12.47	30.87			
	U	W	Q	V	P	R	DC	DB	DA	DP
X	-0.0306	0.1052	-0.0983	0.0022	-0.4856	-0.1999	0.2403	0.1417	-0.0019	-0.0171
Z	0.0374	-1.0037	-0.3630	-0.0704	-0.7241	0.9708	-2.2366	0.4154	0.0165	-0.0032
M	-0.0010	-0.0580	-0.1403	-0.0010	0.1543	0.0410	-0.0329	-0.0673	-0.0006	0.0263
Y	0.0103	-0.0383	-0.6107	-0.1256	0.1460	0.6272	-0.0905	0.0187	0.1237	0.2516
L*	-0.0067	-0.0274	-1.6197	-0.0429	0.0268	0.0427	0.0192	0.0111	0.2235	0.1248
N*	-0.0302	0.0710	-1.1914	0.0528	-0.5787	-1.1493	0.4012	-0.0296	0.0174	-0.3936

CASE 106	60 KT			-9 M/S	SEA LEVEL	2948 KG	AFT CG			
	PHI	THETA	PSI	ALPHA	BETA	GAMMA	ΘMR	B1S	A1S	ΘTR
	-0.21	-1.15	0.00	15.49	-0.06	-16.64	8.20	1.72	-0.36	-0.19
	XDOT	ZDOT		U0	V0	W0	VTO			
	29.57	8.84		29.75	-0.03	8.24	30.87			
	U	W	Q	V	P	R	DC	DB	DA	DP
X	-0.0170	-0.0192	1.0002	-0.0006	-0.5132	-0.0262	0.0207	0.1286	0.0021	-0.0021
Z	-0.1031	-0.9997	-0.4602	-0.0123	-0.4295	0.2231	-2.1848	0.4348	0.0105	-0.0026
M	0.0052	-0.0164	-0.4188	-0.0019	0.1830	0.0113	0.0357	-0.0550	-0.0010	0.0017
Y	-0.0003	0.0158	-0.4733	-0.1587	-0.9699	0.4344	0.0372	-0.0010	0.0921	0.2565
L*	-0.0088	0.0018	-0.9117	-0.0978	-1.8128	-0.0453	0.0461	0.0134	0.1705	0.0892
N*	-0.0066	-0.0709	-0.2162	0.0561	-0.2487	-0.9144	-0.0442	0.0366	0.0165	-0.4334

TABLE IV-3 CONTINUED
 AH-IG STABILITY AND CONTROL DERIVATIVES -- SI UNITS
 (BODY-FIXED FRL AXIS SYSTEM)

CASE 107	1 KT LEVEL FLIGHT AT SEA LEVEL 4309 KG MID CG									
	PHI	THETA	PSI	ALPHA	BETA	GAMMA	ΘMR	B1S	A1S	ΘTR
	-1.13	-0.61	0.00	-0.61	0.01	0.00	15.83	-0.60	-1.92	10.06
	XDOT		ZDOT	U0	V0	W0	VT0			
	0.51		0.00	0.51	0.00	-0.01	0.51			
	U	W	Q	V	P	R	DC	DB	DA	DP
X	-0.0172	-0.0139	0.1639	-0.0282	-0.5081	-0.0158	-0.0166	0.1579	0.0042	-0.0025
Z	-0.0978	-0.3236	-0.0065	-0.0781	-0.0427	0.6394	-1.3340	0.0211	-0.0005	-0.0039
H	0.0033	-0.0128	-0.2970	0.0044	0.2455	0.0057	-0.0021	-0.0751	-0.0021	0.0045
Y	0.0194	-0.0036	-0.4226	-0.0524	-0.3589	0.2199	-0.0525	-0.0034	0.1055	0.1631
L*	0.0360	-0.0156	-0.9894	-0.0386	-0.8294	0.0393	-0.0254	-0.0077	0.2137	0.1459
M*	-0.0026	-0.0139	-0.1273	0.0502	-0.3701	-0.5345	0.2427	-0.0018	0.0132	-0.3016

CASE 108	60 KT LEVEL FLIGHT AT SEA LEVEL 4309 KG MID CG									
	PHI	THETA	PSI	ALPHA	BETA	GAMMA	ΘMR	B1S	A1S	ΘTR
	-0.65	-2.03	0.00	-2.03	0.02	0.00	13.28	1.02	-1.78	3.07
	XDOT		ZDOT	U0	V0	W0	VT0			
	30.87		0.00	30.85	0.01	-1.09	30.87			
	U	W	Q	V	P	R	DC	DB	DA	DP
X	-0.0267	-0.0255	0.5196	-0.0049	-0.4357	-0.0279	-0.0725	0.1582	0.0033	-0.0070
Z	-0.1007	-0.6992	-0.3395	-0.0237	-0.3777	0.5289	-1.5067	0.2992	0.0110	-0.0073
H	0.0084	-0.0084	-0.3635	0.0006	0.1991	0.0237	0.0160	-0.0759	-0.0019	0.0075
Y	-0.0006	0.0012	-0.3789	-0.0893	-0.6260	0.3202	-0.0034	0.0030	0.1018	0.1806
L*	-0.0113	-0.0050	-0.6337	-0.0318	-1.3481	0.0652	0.0384	0.0110	0.2069	0.1608
M*	-0.0169	-0.0265	0.3310	0.0413	-0.3433	-0.8298	0.1366	0.0157	0.0108	-0.3338

CASE 109	100 KT LEVEL FLIGHT AT SEA LEVEL 4309 KG MID CG									
	PHI	THETA	PSI	ALPHA	BETA	GAMMA	ΘMR	B1S	A1S	ΘTR
	-0.86	-2.97	0.00	-2.97	0.04	0.00	13.72	3.27	-1.42	2.43
	XDOT		ZDOT	U0	V0	W0	VT0			
	51.44		0.00	51.38	0.04	-2.66	51.44			
	U	W	Q	V	P	R	DC	DB	DA	DP
X	-0.0326	-0.0222	0.5120	-0.0018	-0.4106	-0.0349	-0.0795	0.1562	0.0022	-0.0108
Z	-0.0509	-0.8265	-0.8144	-0.0193	-0.6460	0.5640	-1.7606	0.5585	0.0194	-0.0120
H	0.0101	-0.0156	-0.4252	-0.0022	0.1821	0.0407	0.0138	-0.0801	-0.0016	0.0128
Y	0.0025	-0.0071	-0.3907	-0.1253	-0.5506	0.4394	-0.0158	0.0097	0.1021	0.2034
L*	-0.0046	-0.0186	-0.6749	-0.0296	-1.1904	0.0980	0.0103	0.0267	0.2077	0.1758
M*	-0.0116	-0.0235	0.2342	0.0430	-0.3009	-1.0906	0.1258	0.0245	0.0107	-0.3815

TABLE IV-3 CONTINUED
 AH-IG STABILITY AND CONTROL DERIVATIVES -- SI UNITS
 (BODY-FIXED FRL AXIS SYSTEM)

CASE 110	1 KT		LEVEL FLIGHT AT SEA LEVEL			4309 KG	FWD CG			
	PHI	THETA	PSI	ALPHA	BETA	GAMMA	ΘMR	B1S	A1S	ΘTR
	-1.10	-3.10	0.00	-3.10	0.06	0.00	15.82	-2.84	-1.94	10.02
	XDOT		ZDOT	U0	V0	W0	VT0			
	0.51		0.00	0.51	0.00	-0.03	0.51			
	U	W	Q	V	P	R	DC	DB	DA	DP
X	-0.0225	-0.0269	0.1603	-0.0314	-0.5093	0.0248	-0.0754	0.1562	0.0049	-0.0007
Z	-0.1211	-0.3229	0.0067	-0.0761	0.0007	0.6378	-1.3328	0.0218	-0.0006	-0.0031
M	0.0030	-0.0136	-0.2923	0.0043	0.2461	0.0004	-0.0032	-0.0742	-0.0026	0.0031
Y	0.0186	-0.0038	-0.4211	-0.0521	-0.3539	0.2295	-0.0518	-0.0014	0.1066	0.1668
L'	0.0345	-0.0158	-0.8521	-0.0378	-0.8208	0.0525	-0.0210	-0.0023	0.2153	0.1522
N'	-0.0029	-0.0137	0.2552	0.0513	-0.3714	-0.5421	0.2458	-0.0020	0.0108	-0.3048

CASE 111	60 KT		LEVEL FLIGHT AT SEA LEVEL			4309 KG	FWD CG			
	PHI	THETA	PSI	ALPHA	BETA	GAMMA	ΘMR	B1S	A1S	ΘTR
	-0.62	-4.28	0.00	-4.28	0.05	0.00	13.32	-1.08	-1.75	3.03
	XDOT		ZDOT	U0	V0	W0	VT0			
	30.87		0.00	30.78	0.02	-2.30	30.87			
	U	W	Q	V	P	R	DC	DB	DA	DP
X	-0.0324	-0.0520	0.4535	-0.0061	-0.4575	-0.0049	-0.1372	0.1656	0.0032	-0.0118
Z	-0.1228	-0.6954	-0.4539	-0.0229	-0.3465	0.5372	-1.5103	0.2873	0.0096	-0.0141
M	0.0086	-0.0109	-0.3468	0.0007	0.2029	0.0255	0.0151	-0.0717	-0.0016	0.0099
Y	-0.0007	0.0012	-0.3811	-0.0882	-0.6295	0.3303	-0.0039	0.0027	0.1024	0.1801
L'	-0.0118	-0.0043	-0.5116	-0.0343	-1.3536	0.0653	0.0391	0.0119	0.2075	0.1602
N'	-0.0182	-0.0264	0.6846	0.0435	-0.3339	-0.8549	0.1377	0.0158	0.0083	-0.3376

CASE 112	7 KT		4 M/S	SEA LEVEL		4309 KG	FWD CG			
	PHI	THETA	PSI	ALPHA	BETA	GAMMA	ΘMR	B1S	A1S	ΘTR
	-1.33	-2.27	0.00	-92.28	1.33	90.00	16.65	-2.18	-2.21	11.27
	XDOT		ZDOT	U0	V0	W0	VT0			
	0.00		-3.66	-0.15	0.08	-3.65	3.66			
	U	W	Q	V	P	R	DC	DB	DA	DP
X	-0.0222	-0.0180	0.1952	-0.0194	-0.5220	-0.0066	-0.0636	0.1517	-0.0002	-0.0157
Z	-0.0663	-0.3644	-0.1318	-0.0761	-0.0286	0.6831	-1.3407	0.0172	0.0004	0.0026
M	0.0127	-0.0213	-0.3061	0.0060	0.2502	0.0021	-0.0063	-0.0701	0.0010	0.0245
Y	0.0141	-0.0202	-0.5809	-0.0604	-0.3097	0.2294	-0.0738	-0.0130	0.1017	0.1494
L'	0.0302	-0.0278	-0.9899	-0.0430	-0.7487	0.0322	-0.0519	-0.0239	0.2063	0.1154
N'	0.0031	0.0181	0.1912	0.0544	-0.4377	-0.5872	0.2778	-0.0032	0.0106	-0.3140

TABLE IV-3 CONTINUED
 AH-IG STABILITY AND CONTROL DERIVATIVES -- SI UNITS
 (BODY-FIXED FRL AXIS SYSTEM)

CASE 113	61 KT			10 M/S			SEA LEVEL	4309 KG	FWD CG	
	PHI	THETA	PSI	ALPHA	BETA	GAMMA	ΘMR	B1S	A1S	ΘTR
	-1.46	-1.99	0.00	-19.79	0.49	17.81	17.03	1.51	-3.09	8.42
	XDOT	ZDOT	U0	V0	W0	VT0				
	29.79	-9.57	29.44	0.27	-10.59	31.29				
	U	W	Q	V	P	R	DC	DB	DA	DP
X	-0.0257	-0.0210	0.2641	-0.0055	-0.4413	-0.0182	-0.0850	0.1864	0.0097	-0.0011
Z	-0.0748	-0.6817	-0.3949	-0.0428	-0.3917	0.8029	-1.5340	0.3057	0.0245	0.0229
H	0.0103	-0.0357	-0.1496	-0.0007	0.1724	0.0475	-0.0425	-0.0690	-0.0037	0.0184
Y	0.0017	-0.0180	-0.4464	-0.0949	-0.3061	0.4185	-0.0451	0.0107	0.1165	0.1876
L'	-0.0103	-0.0187	-0.7384	-0.0619	-0.7443	0.1455	0.0123	0.0186	0.2318	0.1781
H'	-0.0207	0.0268	0.3551	0.0373	-0.4980	-0.9850	0.3075	-0.0061	0.0095	-0.3281

CASE 114	60 KT			-8 M/S			SEA LEVEL	4309 KG	FWD CG	
	PHI	THETA	PSI	ALPHA	BETA	GAMMA	ΘMR	B1S	A1S	ΘTR
	-0.08	-5.32	0.00	9.85	-0.01	-15.17	10.07	-2.93	-0.70	-0.37
	XDOT	ZDOT	U0	V0	W0	VT0				
	29.79	8.08	30.41	-0.01	5.28	30.87				
	U	W	Q	V	P	R	DC	DB	DA	DP
X	-0.0309	-0.0571	0.6610	-0.0051	-0.4400	0.0081	-0.1685	0.1601	0.0035	-0.0043
Z	-0.1478	-0.6651	-0.5544	-0.0099	-0.2110	0.3590	-1.4475	0.2597	0.0098	-0.0111
H	0.0055	-0.0071	-0.4316	-0.0002	0.2083	0.0177	0.0267	-0.0677	-0.0016	0.0025
Y	-0.0015	0.0123	-0.3407	-0.0994	-0.8377	0.2852	0.0271	-0.0014	0.0941	0.1866
L'	-0.0111	0.0054	-0.4174	0.0002	-1.7378	0.0327	0.0611	0.0065	0.1928	0.1575
H'	-0.0164	-0.0578	0.7914	0.0425	-0.1924	-0.7900	0.0217	0.0291	0.0087	-0.3556

CASE 115	1 KT			LEVEL FLIGHT AT SEA LEVEL			4309 KG	AFT CG		
	PHI	THETA	PSI	ALPHA	BETA	GAMMA	ΘMR	B1S	A1S	ΘTR
	-1.18	2.60	0.00	2.60	-0.05	0.00	15.83	2.27	-1.90	10.11
	XDOT	ZDOT	U0	V0	W0	VT0				
	0.51	0.00	0.51	-0.00	0.02	0.51				
	U	W	Q	V	P	R	DC	DB	DA	DP
X	-0.0133	0.0029	0.1784	-0.0201	-0.4954	-0.0623	0.0615	0.1634	0.0048	0.0000
Z	-0.0685	-0.3233	-0.0184	-0.0799	-0.0981	0.6361	-1.3335	0.0215	-0.0002	-0.0039
H	0.0033	-0.0119	-0.3121	0.0050	0.2379	0.0050	-0.0034	-0.0797	-0.0035	0.0000
Y	0.0215	-0.0020	-0.3849	-0.0515	-0.3304	0.2453	-0.0377	0.0108	0.1149	0.1926
L'	0.0404	-0.0124	-1.0693	-0.0766	-0.7636	0.1064	0.0040	0.0221	0.2359	0.2132
H'	-0.0018	-0.0139	-0.6087	0.0489	-0.3610	-0.5155	0.2434	0.0014	0.0184	-0.2906

TABLE IV-3 CONCLUDED
 AH-1G STABILITY AND CONTROL DERIVATIVES -- SI UNITS
 (BODY-FIXED FRL AXIS SYSTEM)

CASE 116		60 KT	LEVEL FLIGHT AT SEA LEVEL			4309 KG	AFT CG			
	PHI	THETA	PSI	ALPHA	BETA	GAMMA	ΘHR	B1S	A1S	ΘTR
	-0.69	0.82	0.00	0.92	-0.01	0.00	13.24	3.71	-1.81	3.13
	XDOT	ZDOT	UO	VO	WO	VT0				
	30.87	0.00	30.86	-0.01	0.44	30.87				
	U	W	Q	V	P	R	DC	DB	DA	DP
X	-0.0223	0.0085	0.5852	-0.0037	-0.4105	-0.0613	0.0075	0.1452	0.0017	-0.0065
Z	-0.0721	-0.7035	-0.2000	-0.0251	-0.4266	0.5055	-1.5046	0.3102	0.0091	-0.0085
M	0.0079	-0.0052	-0.3831	0.0006	0.1979	0.0244	0.0185	-0.0803	-0.0014	0.0070
Y	-0.0003	0.0010	-0.3753	-0.0912	-0.6237	0.3075	-0.0029	0.0033	0.1007	0.1815
L'	-0.0102	-0.0059	-0.7796	-0.0282	-1.3447	0.0661	0.0377	0.0102	0.2059	0.1625
M'	-0.0150	-0.0265	-0.1207	0.0381	-0.3563	-0.7989	0.1355	0.0153	0.0139	-0.3300

CASE 117		60 KT	10 M/S	SEA LEVEL		4309 KG	AFT CG			
	PHI	THETA	PSI	ALPHA	BETA	GAMMA	ΘHR	B1S	A1S	ΘTR
	-1.53	2.74	0.00	-15.79	0.42	18.54	16.98	5.58	-3.16	8.50
	XDOT	ZDOT	UO	VO	WO	VT0				
	29.26	-9.81	29.70	0.22	-8.40	30.87				
	U	W	Q	V	P	R	DC	DB	DA	DP
X	-0.0287	0.0198	0.2525	-0.0015	-0.4051	-0.1119	0.0565	0.1515	0.0017	-0.0138
Z	-0.0355	-0.6825	-0.3022	-0.0453	-0.4902	0.7270	-1.5174	0.2968	0.0129	-0.0062
M	0.0107	-0.0173	-0.2737	-0.0003	0.1923	0.0391	0.0036	-0.0870	-0.0019	0.0220
Y	0.0032	-0.0172	-0.4372	-0.0934	-0.3109	0.3823	-0.0442	0.0118	0.1146	0.1882
L'	-0.0075	-0.0184	-0.9856	-0.0598	-0.7520	0.1410	0.0073	0.0171	0.2311	0.1831
M'	-0.0220	0.0260	-0.3513	0.0304	-0.5055	-0.9097	0.2971	-0.0102	0.0130	-0.3241

CASE 118		60 KT	-9 M/S	SEA LEVEL		4309 KG	AFT CG			
	PHI	THETA	PSI	ALPHA	BETA	GAMMA	ΘHR	B1S	A1S	ΘTR
	-0.09	-0.60	0.00	15.92	-0.02	-16.52	9.90	1.96	-0.75	-0.36
	XDOT	ZDOT	UO	VO	WO	VT0				
	29.59	8.78	29.68	-0.01	8.47	30.87				
	U	W	Q	V	P	R	DC	DB	DA	DP
X	-0.0161	-0.0306	0.8181	-0.0031	-0.4035	-0.0366	-0.0144	0.1401	0.0020	-0.0005
Z	-0.1026	-0.6324	-0.3363	-0.0136	-0.2861	0.3355	-1.4551	0.2786	0.0096	-0.0061
M	0.0068	-0.0163	-0.4657	-0.0005	0.2041	0.0189	0.0343	-0.0764	-0.0016	0.0008
Y	-0.0025	0.0111	-0.3492	-0.1135	-0.8401	0.2635	0.0268	-0.0032	0.0922	0.1846
L'	-0.0118	0.0089	-0.6899	0.0268	-1.7502	0.0245	0.0604	0.0031	0.1912	0.1554
M'	-0.0105	-0.0571	-0.0103	0.0400	-0.2278	-0.7448	0.0220	0.0305	0.0150	-0.3458

TABLE IV-4
AH-1G STABILITY AND CONTROL DERIVATIVES -- US UNITS
(BODY-FIXED FRL AXIS SYSTEM)

CASE 56		-40 KT		LEVEL FLIGHT AT SEA LEVEL			8000 LB	MID CG		
	PHI	THETA	PSI	ALPHA	BETA	GAMMA	ΘMR	B1S	A1S	ΘTR
	-0.75	-2.43	0.00	177.57	-0.03	180.00	12.72	-4.46	-0.13	3.41
	XDOT		ZDOT	U0	V0	W0	VT0			
	-67.51		0.00	-67.45	-0.04	2.87	67.51			
	U	W	Q	V	P	R	DC	DB	DA	DP
X	-0.0136	-0.0434	1.6395	-0.0021	-1.5035	0.1217	-0.4800	1.1679	0.0433	0.1869
Z	0.1286	-0.6508	0.2369	-0.0093	1.0227	1.7931	-13.4701	-1.8621	-0.1004	-0.0877
M	0.0018	0.0027	-0.1329	0.0006	0.1793	-0.0082	-0.0295	-0.1541	-0.0065	-0.0269
Y	-0.0019	-0.0249	-1.5326	-0.0429	-1.8438	0.5650	-0.4874	-0.1026	0.8243	1.5756
L'	0.0019	-0.0173	-0.7887	-0.0057	-1.0348	0.0873	-0.1477	-0.0723	0.4784	0.3088
N'	0.0046	-0.0079	0.3078	0.0065	-0.0414	-0.4312	0.3508	-0.0304	0.0332	-0.8177

CASE 57		-20 KT		LEVEL FLIGHT AT SEA LEVEL			8000 LB	MID CG		
	PHI	THETA	PSI	ALPHA	BETA	GAMMA	ΘMR	B1S	A1S	ΘTR
	-0.97	-2.95	0.00	177.05	-0.05	180.00	13.79	-3.99	-0.53	5.75
	XDOT		ZDOT	U0	V0	W0	VT0			
	-33.76		0.00	-33.71	-0.03	1.74	33.76			
	U	W	Q	V	P	R	DC	DB	DA	DP
X	0.0028	-0.0369	1.1267	-0.0032	-1.5259	0.1156	-0.4286	1.3493	0.1261	0.3919
Z	0.2097	-0.4833	-0.9979	-0.0246	0.5470	1.7875	-12.2503	-0.8752	-0.0759	-0.0979
M	0.0034	-0.0004	-0.1475	0.0009	0.1847	-0.0166	-0.0359	-0.1745	-0.0182	-0.0432
Y	0.0009	-0.0151	-1.5411	-0.0407	-1.3228	0.5782	-0.3639	0.0190	0.8954	1.5810
L'	0.0067	-0.0123	-0.8199	-0.0075	-0.7311	0.0787	-0.0397	-0.0055	0.5115	0.3193
N'	0.0076	-0.0054	0.3394	0.0083	-0.1375	-0.3874	0.4758	-0.0114	0.0354	-0.7695

CASE 58		-10 KT		LEVEL FLIGHT AT SEA LEVEL			8000 LB	MID CG		
	PHI	THETA	PSI	ALPHA	BETA	GAMMA	ΘMR	B1S	A1S	ΘTR
	-1.07	-1.92	0.00	178.08	-0.04	180.00	14.41	-2.79	-1.08	7.34
	XDOT		ZDOT	U0	V0	W0	VT0			
	-16.88		0.00	-16.87	-0.01	0.56	16.88			
	U	W	Q	V	P	R	DC	DB	DA	DP
X	-0.0208	-0.0211	0.7565	-0.0101	-1.8146	-0.1419	-0.5291	1.1474	-0.0274	-0.0904
Z	0.1777	-0.4042	-1.1236	-0.0405	0.3318	2.0194	-12.3492	-0.2476	0.0132	0.1051
M	0.0077	-0.0037	-0.2056	0.0016	0.2236	0.0162	0.0090	-0.1397	0.0041	0.0280
Y	0.0058	-0.0141	-1.7777	-0.0477	-1.1490	0.6346	-0.4689	-0.0716	0.8442	1.4108
L'	0.0095	-0.0087	-0.9046	-0.0073	-0.7256	0.0249	-0.0536	-0.0360	0.4964	0.2807
N'	0.0068	-0.0023	0.2837	0.0122	-0.2406	-0.4796	0.5408	-0.0148	0.0346	-0.7780

TABLE IV-4 CONTINUED
 AH-IG STABILITY AND CONTROL DERIVATIVES -- US UNITS
 (BODY-FIXED FRL AXIS SYSTEM)

CASE	1 KT		LEVEL FLIGHT AT SEA LEVEL				8000 LB	MID CG		
	PHI	THETA	PSI	ALPHA	BETA	GAMMA	ΘMR	B1S	A1S	ΘTR
	-1.15	-0.71	0.00	-0.73	0.01	0.00	14.83	-0.76	-1.80	8.40
		XDOT	ZDOT	U0	V0	W0		VTO		
		1.69	0.00	1.69	0.00	-0.02		1.69		
	U	W	Q	V	P	R	DC	DR	DA	DP
X	-0.0165	-0.0155	0.3655	-0.0285	-1.8499	-0.1273	-0.2560	1.2425	-0.0130	-0.1453
Z	-0.1208	-0.3726	-0.0110	-0.0932	-0.1345	2.0756	-12.7606	0.1799	-0.0035	-0.0305
M	0.0005	-0.0033	-0.2345	0.0007	0.2305	0.0175	0.0076	-0.1462	0.0035	0.0322
Y	0.0173	-0.0051	-1.5941	-0.0552	-1.1026	0.7182	-0.5515	-0.1182	0.8095	1.2837
L*	0.0085	-0.0060	-1.0559	-0.0087	-0.7662	-0.0403	-0.0925	-0.0686	0.4709	0.1816
N*	-0.0012	-0.0047	-0.1161	0.0158	-0.3945	-0.5366	0.5795	-0.0095	0.0319	-0.8120

CASE	10 KT		LEVEL FLIGHT AT SEA LEVEL				8000 LB	MID CG		
	PHI	THETA	PSI	ALPHA	BETA	GAMMA	ΘMR	B1S	A1S	ΘTR
	-1.05	-1.10	0.00	-1.10	0.02	0.00	14.42	-0.69	-2.02	7.52
		XDOT	ZDOT	U0	V0	W0		VTO		
		16.88	0.00	16.87	0.01	-0.32		16.88		
	U	W	Q	V	P	R	DC	DR	DA	DP
X	-0.0163	-0.0106	0.9706	-0.0154	-1.7470	-0.0595	-0.2890	1.3148	0.0403	-0.0044
Z	-0.2090	-0.4060	0.8210	-0.0530	-0.3136	1.9603	-12.3576	0.4270	0.0170	-0.0210
M	0.0002	-0.0026	-0.2299	0.0017	0.2141	0.0049	0.0085	-0.1607	-0.0056	0.0036
Y	0.0180	0.0002	-1.5623	-0.0562	-1.1609	0.8066	-0.3238	0.0141	0.9870	1.4888
L*	0.0068	-0.0033	-0.9165	-0.0063	-0.8109	0.0164	0.0198	0.0073	0.5144	0.3136
N*	-0.0040	-0.0044	0.0522	0.0133	-0.4245	-0.5325	0.5436	-0.0008	0.0351	-0.7733

CASE	20 KT		LEVEL FLIGHT AT SEA LEVEL				8000 LB	MID CG		
	PHI	THETA	PSI	ALPHA	BETA	GAMMA	ΘMR	B1S	A1S	ΘTR
	-0.91	-1.59	0.00	-1.59	0.03	0.00	13.81	-0.73	-2.12	6.11
		XDOT	ZDOT	U0	V0	W0		VTO		
		33.76	0.00	33.74	0.01	-0.93		33.76		
	U	W	Q	V	P	R	DC	DR	DA	DP
X	-0.0283	-0.0194	1.2469	-0.0130	-1.7329	-0.0625	-0.4383	1.3050	0.0265	-0.0516
Z	-0.2485	-0.5022	0.8879	-0.0429	-0.4886	1.8929	-12.1662	0.8473	0.0346	-0.0232
M	0.0004	-0.0018	-0.2289	0.0014	0.2102	0.0058	0.0258	-0.1590	-0.0033	0.0106
Y	0.0142	0.0000	-1.5743	-0.0599	-1.4716	0.8115	-0.2437	0.0037	0.8630	1.3622
L*	0.0016	-0.0021	-0.8371	-0.0064	-0.9889	0.0243	0.0425	0.0041	0.5018	0.2706
N*	-0.0064	-0.0037	0.1957	0.0119	-0.4410	-0.5433	0.4781	0.0072	0.0341	-0.7323

TABLE IV-4 CONTINUED
 AH-IG STABILITY AND CONTROL DERIVATIVES -- US UNITS
 (BODY-FIXED FRL AXIS SYSTEM)

CASE	40 KT		LEVEL FLIGHT AT SEA LEVEL				8000 LB	MID CG		
	PHI	THETA	PSI	ALPHA	BETA	GAMMA	QMR	B1S	A1S	QTR
CASE 62	-0.71	-1.81	0.00	-1.91	0.02	0.00	12.77	-0.10	-1.93	3.49
	XDOT	ZDOT	U0	V0	W0	VT0				
	67.51	0.00	67.48	0.03	-2.13	67.51				
	U	W	Q	V	P	R	DC	DB	DA	DP
X	-0.0273	-0.0263	1.5624	-0.0084	-1.6517	-0.0980	-0.5425	1.3186	0.0156	-0.0750
Z	-0.1688	-0.7094	-0.2633	-0.0315	-0.9439	1.6536	-13.2839	1.8147	0.0528	-0.0696
M	0.0017	-0.0023	-0.2805	0.0007	0.1951	0.0149	0.0304	-0.1590	-0.0023	0.0151
Y	0.0081	0.0017	-1.5067	-0.0793	-1.9277	1.0265	-0.0712	0.0378	0.8501	1.4574
L*	0.0005	-0.0014	-0.7411	-0.0060	-1.2312	0.0250	0.0989	0.0327	0.4938	0.2938
N*	-0.0061	-0.0063	0.2837	0.0128	-0.4142	-0.7310	0.3660	0.0273	0.0295	-0.7841
CASE 63	60 KT		LEVEL FLIGHT AT SEA LEVEL				8000 LB	MID CG		
	PHI	THETA	PSI	ALPHA	BETA	GAMMA	QMR	B1S	A1S	QTR
	-0.69	-2.25	0.00	-2.25	0.03	0.00	12.42	0.70	-1.54	2.39
	XDOT	ZDOT	U0	V0	W0	VT0				
	101.27	0.00	101.19	0.05	-3.98	101.27				
	U	W	Q	V	P	R	DC	DB	DA	DP
X	-0.0268	-0.0286	1.7170	-0.0046	-1.6068	-0.0668	-0.6761	1.3088	0.0163	-0.0506
Z	-0.1060	-0.8377	-1.4214	-0.0246	-1.4280	1.7699	-15.0092	2.9518	0.0733	-0.0848
M	0.0019	-0.0030	-0.3244	0.0000	0.1854	0.0199	0.0287	-0.1574	-0.0029	0.0152
Y	0.0006	-0.0003	-1.4114	-0.1019	-2.0445	1.3044	-0.0597	0.0196	0.8415	1.7390
L*	-0.0031	-0.0031	-0.6703	-0.0046	-1.2781	0.0375	0.0774	0.0227	0.4875	0.3409
N*	-0.0048	-0.0087	0.3029	0.0144	-0.3518	-0.8970	0.2937	0.0342	0.0268	-0.9430
CASE 64	80 KT		LEVEL FLIGHT AT SEA LEVEL				8000 LB	MID CG		
	PHI	THETA	PSI	ALPHA	BETA	GAMMA	QMR	B1S	A1S	QTR
	-0.78	-2.71	0.00	-2.71	0.04	0.00	12.55	1.77	-1.31	2.02
	XDOT	ZDOT	U0	V0	W0	VT0				
	135.02	0.00	134.87	0.09	-6.38	135.02				
	U	W	Q	V	P	R	DC	DB	DA	DP
X	-0.0296	-0.0261	1.7664	-0.0027	-1.5508	-0.0997	-0.6853	1.3064	0.0158	-0.1066
Z	-0.0731	-0.9243	-2.3562	-0.0213	-1.9744	1.7432	-16.4353	4.2224	0.0954	-0.1037
M	0.0022	-0.0042	-0.3656	-0.0004	0.1734	0.0251	0.0195	-0.1618	-0.0042	0.0238
Y	0.0022	-0.0051	-1.4299	-0.1236	-1.9600	1.5329	-0.0941	0.0627	0.8514	1.8191
L*	-0.0021	-0.0056	-0.6993	-0.0033	-1.2282	0.0351	0.0426	0.0494	0.4912	0.3369
N*	-0.0042	-0.0093	0.2397	0.0150	-0.3360	-1.0518	0.2546	0.0459	0.0232	-1.0179

TABLE IV-4 CONTINUED
 AH-IG STABILITY AND CONTROL DERIVATIVES -- US UNITS
 (BODY-FIXED FRL AXIS SYSTEM)

CASE 65	100 KT			LEVEL FLIGHT AT SEA LEVEL			8000 LB	MID CG		
	PHI	THETA	PSI	ALPHA	BETA	GAMMA	ΘHR	BIS	AIS	ΘTR
	-0.99	-3.34	0.00	-3.34	0.06	0.00	13.06	3.06	-1.29	2.03
	XDOT	ZDOT	U0	V0	W0	VT0				
	168.78	0.00	168.49	0.17	-9.83	168.78				
	U	W	Q	V	P	R	DC	DB	DA	DP
X	-0.0353	-0.0206	1.6410	-0.0022	-1.5577	-0.0754	-0.6101	1.2576	0.0048	-0.0974
Z	-0.0520	-0.9907	-3.1263	-0.0216	-2.5720	1.8685	-17.6603	5.5388	0.1214	-0.1588
M	0.0026	-0.0058	-0.3849	-0.0007	0.1739	0.0329	0.0062	-0.1644	-0.0021	0.0298
Y	0.0031	-0.0112	-1.4483	-0.1451	-1.7498	1.7320	-0.1954	0.0842	0.8395	1.9284
L*	-0.0015	-0.0081	-0.7296	-0.0025	-1.1043	0.0254	-0.0069	0.0641	0.4858	0.3537
N*	-0.0032	-0.0076	0.1597	0.0152	-0.3083	-1.1848	0.2738	0.0542	0.0263	-1.0719

CASE 66	120 KT			LEVEL FLIGHT AT SEA LEVEL			8000 LB	MID CG		
	PHI	THETA	PSI	ALPHA	BETA	GAMMA	ΘHR	BIS	AIS	ΘTR
	-1.32	-4.24	0.00	-4.24	0.10	0.00	14.03	4.67	-1.52	2.49
	XDOT	ZDOT	U0	V0	W0	VT0				
	202.54	0.00	201.98	0.35	-14.97	202.54				
	U	W	Q	V	P	R	DC	DB	DA	DP
X	-0.0416	-0.0105	1.5357	-0.0011	-1.4691	-0.1026	-0.4136	1.1830	0.0009	-0.1345
Z	-0.0337	-1.0451	-3.5457	-0.0266	-3.1835	2.0681	-18.7277	6.8985	0.1534	-0.1602
M	0.0029	-0.0080	-0.4074	-0.0011	0.1566	0.0391	-0.0206	-0.1762	-0.0020	0.0450
Y	0.0044	-0.0204	-1.4747	-0.1659	-1.3656	1.9750	-0.3545	0.1576	0.8505	1.9970
L*	-0.0008	-0.0109	-0.8015	-0.0026	-0.9010	0.0414	-0.0608	0.0971	0.4933	0.3611
N*	-0.0023	-0.0028	-0.0174	0.0145	-0.3474	-1.3367	0.3666	0.0320	0.0288	-1.1193

CASE 67	140 KT			LEVEL FLIGHT AT SEA LEVEL			8000 LB	MID CG		
	PHI	THETA	PSI	ALPHA	BETA	GAMMA	ΘHR	BIS	AIS	ΘTR
	-1.79	-5.54	0.00	-5.54	0.17	0.00	15.57	6.59	-2.02	3.49
	XDOT	ZDOT	U0	V0	W0	VT0				
	236.29	0.00	235.19	0.71	-22.82	236.29				
	U	W	Q	V	P	R	DC	DB	DA	DP
X	-0.0514	0.0025	1.3483	0.0001	-1.3803	-0.1495	-0.1154	1.0837	-0.0026	-3.1796
Z	-0.0204	-1.0882	-3.4267	-0.0374	-3.8656	2.3527	-19.7911	8.4228	0.1864	-0.1762
M	0.0034	-0.0108	-0.4162	-0.0017	0.1370	0.0509	-0.0621	-0.1978	-0.0033	0.0693
Y	0.0057	-0.0313	-1.5773	-0.1871	-0.8233	2.2114	-0.6064	0.2766	0.8775	2.0303
L*	0.0000	-0.0128	-0.9581	-0.0041	-0.6093	0.0347	-0.1278	0.1278	0.5051	0.3525
N*	-0.0013	0.0069	-0.2939	0.0136	-0.3334	-1.5129	0.5729	-0.0518	0.0268	-1.1473

TABLE IV-4 CONTINUED
 AH-IG STABILITY AND CONTROL DERIVATIVES -- US UNITS
 (BODY-FIXED FRL AXIS SYSTEM)

CASE	68	17 KT	1600 FT/MIN	SEA LEVEL	8000 LB	MID CG				
	PHI	THETA	PSI	ALPHA	BETA	GAMMA	ΘMR	BIS	AIS	ΘTR
	-1.77	2.83	0.00	-87.17	1.76	90.00	16.91	2.19	-2.51	11.02
	XDOT	ZDOT	U0	V0	W0	VT0				
	0.00	-29.00	1.38	0.86	-27.95	28.00				
	U	W	Q	V	P	R	DC	DB	DA	DP
X	-0.0253	0.0123	0.2220	-0.0176	-1.7281	-0.2172	0.6178	1.4451	0.0391	0.0152
Z	-0.0497	-0.5069	-0.6278	-0.0966	-0.6719	2.4938	-13.2066	0.1308	-0.0026	-0.0413
M	-0.0001	-0.0135	-0.3009	-0.0005	0.2015	-0.0042	-0.0871	-0.1681	-0.0032	0.0575
Y	0.0102	-0.0293	-2.1566	-0.0809	-0.4684	1.0063	-0.7602	-0.1126	0.8818	1.4438
L'	0.0071	-0.0102	-1.3200	-0.0103	-0.4366	0.0156	-0.1402	-0.0825	0.5017	0.2037
N'	0.0017	0.0118	-0.3402	0.0211	-0.4774	-0.6729	0.8001	-0.0092	0.0331	-0.8749

CASE	69	60 KT	2340 FT/MIN	SEA LEVEL	9000 LB	MID CG				
	PHI	THETA	PSI	ALPHA	BETA	GAMMA	ΘMR	BIS	AIS	ΘTR
	-1.80	1.13	0.00	-21.51	0.66	22.65	16.95	4.01	-3.09	8.05
	XDOT	ZDOT	U0	V0	W0	VT0				
	93.45	-39.00	94.21	1.17	-37.12	101.26				
	U	W	Q	V	P	R	DC	DB	DA	DP
X	-0.0245	0.0153	0.3588	-0.0035	-1.5488	-0.2863	0.1958	1.3915	0.0303	-0.0772
Z	-0.0444	-0.8153	-1.5760	-0.0526	-1.6316	2.8159	-15.0426	2.8635	0.1716	0.0943
M	0.0008	-0.0144	-0.2218	-0.0003	0.1638	0.0344	-0.0520	-0.1830	-0.0075	0.0460
Y	0.0052	-0.0244	-1.6164	-0.1062	-0.4266	1.7120	-0.4183	0.1890	1.0458	1.9305
L'	-0.0023	-0.0066	-0.9553	-0.0149	-0.4110	0.1426	0.0840	0.0886	0.5993	0.4882
N'	-0.0069	0.0126	-0.1438	0.0130	-0.5299	-1.0565	0.8490	-0.0380	0.0307	-0.9015

CASE	70	100 KT	2094 FT/MIN	SEA LEVEL	8000 LB	MID CG				
	PHI	THETA	PSI	ALPHA	BETA	GAMMA	ΘMR	BIS	AIS	ΘTR
	-1.92	-1.04	0.00	-12.97	0.43	11.93	17.22	5.82	-2.66	6.21
	XDOT	ZDOT	U0	V0	W0	VT0				
	165.13	-34.90	164.47	1.27	-37.88	168.78				
	U	W	Q	V	P	R	DC	DB	DA	DP
X	-0.0401	0.0049	0.2794	0.0002	-1.4905	-0.2821	0.0619	1.2721	0.0161	-0.2181
Z	-0.0146	-0.9681	-2.7013	-0.0504	-2.7847	2.9070	-17.4890	5.4483	0.1880	0.0145
M	0.0034	-0.0105	-0.2293	-0.0016	0.1492	0.0753	-0.0574	-0.1834	-0.0029	0.1101
Y	0.0047	-0.0332	-1.7859	-0.1490	-0.4503	1.9949	-0.6725	0.1716	0.9729	1.8457
L'	-0.0016	-0.0089	-1.0096	-0.0135	-0.3952	0.0705	-0.0455	0.0563	0.5552	0.3389
N'	-0.0056	0.0165	-0.0673	0.0123	-0.4177	-1.1259	0.8982	-0.0920	0.0270	-1.0262

TABLE IV-4 CONTINUED
 AH-IG STABILITY AND CONTROL DERIVATIVES -- US UNITS
 (BODY-FIXED FRL AXIS SYSTEM)

CASE 71	60 KT		-1866 FT/MIN		SEA LEVEL	8000 LB	MID CG			
	PHI	THETA	PSI	ALPHA	BETA	GAMMA	ΘMR	B1S	A1S	ΘTR
	-0.03	-3.89	0.00	14.01	-0.01	-17.89	8.69	-1.59	-0.39	-0.70
	XDOT		ZDOT	U0	V0	W0	VT0			
	96.37		31.10	98.26	-0.01	24.51	101.27			
	U	W	Q	V	P	R	DC	DB	DA	DP
X	-0.0213	-0.0798	2.7446	-0.0027	-1.5659	-0.0142	-0.9503	1.2597	0.0178	-0.0162
Z	-0.1501	-0.7429	-1.8695	-0.0104	-0.9464	0.9972	-14.6050	2.6869	0.0780	-0.0638
M	0.0014	-0.0057	-0.4218	-0.0004	0.1925	0.0166	0.0735	-0.1484	-0.0028	0.0033
Y	-0.0010	0.0152	-1.2805	-0.1254	-3.0707	1.1363	0.2888	-0.0250	0.7550	1.7517
L*	-0.0030	0.0016	-0.5360	0.0159	-1.8174	0.0115	0.1410	0.0178	0.4452	0.3138
N*	-0.0038	-0.0211	0.4954	0.0152	-0.1969	-0.8372	-0.0638	0.0891	0.0313	-0.9781

CASE 72	100 KT		-2250 FT/MIN		SEA LEVEL	8000 LB	MID CG			
	PHI	THETA	PSI	ALPHA	BETA	GAMMA	ΘMR	B1S	A1S	ΘTR
	-0.31	-5.09	0.00	7.75	-0.04	-12.84	8.04	-0.57	0.22	-0.89
	XDOT		ZDOT	U0	V0	W0	VT0			
	164.56		37.50	167.24	-0.12	22.75	168.78			
	U	W	Q	V	P	R	DC	DB	DA	DP
X	-0.0309	-0.0382	2.8912	-0.0012	-1.5228	-0.0211	-1.1951	1.2392	-0.0015	0.0121
Z	-0.0968	-0.9793	-3.7981	0.0052	-1.9684	0.6510	-17.2565	5.3634	0.1400	-0.1552
M	0.0012	-0.0030	-0.5269	-0.0008	0.1817	0.0106	0.0670	-0.1369	-0.0004	-0.0101
Y	0.0022	0.0187	-1.2229	-0.1615	-3.0246	1.5066	0.3363	-0.0747	0.6749	1.9328
L*	-0.0009	-0.0005	-0.5511	0.0142	-1.7892	-0.0033	0.0890	0.0289	0.4023	0.3269
N*	-0.0012	-0.0282	0.3339	0.0145	-0.1395	-1.0996	-0.2866	0.1943	0.0317	-1.1125

CASE 73	6 KT		-600 FT/MIN		SEA LEVEL	8000 LB	MID CG			
	PHI	THETA	PSI	ALPHA	BETA	GAMMA	ΘMR	B1S	A1S	ΘTR
	-0.95	-1.26	0.00	88.74	-0.95	-90.00	14.23	-1.19	-1.43	7.29
	XDOT		ZDOT	U0	V0	W0	VT0			
	0.00		10.00	0.22	-0.17	10.00	10.00			
	U	W	Q	V	P	R	DC	DB	DA	DP
X	-0.0215	-0.0076	1.0473	-0.0258	-1.7582	-0.1733	-0.2499	1.3292	0.0593	0.0747
Z	-0.0979	-0.3400	-0.3208	-0.0945	-0.0446	1.9528	-12.7944	0.1131	-0.0304	-0.1138
M	0.0018	-0.0032	-0.2386	0.0011	0.2190	-0.0012	-0.0029	-0.1630	-0.0093	-0.0219
Y	0.0251	0.0009	-1.4398	-0.0478	-1.1061	0.9114	-0.3002	0.0621	0.9173	1.5762
L*	0.0192	-0.0024	-0.8115	-0.0071	-0.7279	0.0440	0.0124	0.0359	0.5342	0.3793
N*	-0.0029	-0.0063	-1.0011	0.0149	-0.2062	-0.4814	0.0421	0.0012	0.0342	-0.7501

TABLE IV-4 CONTINUED
AH-IG STABILITY AND CONTROL DERIVATIVES -- US UNITS
(BODY-FIXED FRL AXIS SYSTEM)

CASE	12 KT		-1200 FT/MIN		SEA LEVEL		8000 LB		MID CG	
	PHI	THETA	PSI	ALPHA	BETA	GAMMA	ΘMR	B1S	A1S	ΘTR
	-0.79	-1.72	0.00	88.28	-0.79	-90.00	13.66	-1.65	-1.26	6.02
	XDOT		ZDOT	U0	V0	W0	VT0			
	0.00		20.00	0.60	-0.27	19.99	20.00			
	U	W	Q	V	P	R	DC	DB	DA	DP
X	-0.0247	-0.0090	1.0828	-0.0313	-1.8391	-0.1905	-0.3950	1.2733	0.0400	0.0193
Z	-0.1162	-0.3045	-0.2118	-0.0930	0.0638	1.8056	-12.6874	0.1661	-0.3064	-0.0402
M	0.0034	-0.0033	-0.3153	0.0012	0.2247	0.0058	0.0140	-0.1538	-0.3049	-0.0170
Y	0.0249	0.0038	-1.5073	-0.0507	-1.2292	0.7533	-0.3114	-0.0056	0.8562	1.3675
L'	0.0110	-0.0015	-0.8746	-0.0071	-0.7830	0.0058	0.0084	-0.0038	0.4991	0.2854
N'	-0.0020	-0.0071	0.0524	0.0148	-0.2591	-0.4901	0.4966	-0.0025	0.0360	-0.7192

CASE	6 KT		600 FT/MIN		SEA LEVEL		8000 LB		MID CG	
	PHI	THETA	PSI	ALPHA	BETA	GAMMA	ΘMR	B1S	A1S	ΘTR
	-1.35	0.11	0.00	-89.99	1.35	90.00	15.51	-0.04	-1.98	9.28
	XDOT		ZDOT	U0	V0	W0	VT0			
	0.00		-10.00	0.02	0.24	-10.00	10.00			
	U	W	Q	V	P	R	DC	DB	DA	DP
X	-0.0170	-0.0038	0.6120	-0.0216	-1.7779	-0.0537	0.0056	1.3279	0.0262	-0.0222
Z	-0.0670	-0.4134	-0.4355	-0.0912	-0.2215	2.2223	-12.8109	0.1569	0.0144	0.0348
M	0.0007	-0.0061	-0.2564	0.0007	0.2147	0.0002	-0.0203	-0.1561	-0.0014	0.0325
Y	0.0136	-0.0207	-2.0590	-0.0623	-0.8533	0.8027	-0.6048	-0.1079	0.8346	1.3532
L'	0.0081	-0.0080	-1.1304	-0.0090	-0.6413	-0.0183	-0.1009	-0.0691	0.4811	0.1950
N'	0.0008	0.0051	0.0139	0.0177	-0.4224	-0.5632	0.6532	-0.0078	0.0340	-0.8276

CASE	12 KT		1200 FT/MIN		SEA LEVEL		8000 LB		MID CG	
	PHI	THETA	PSI	ALPHA	BETA	GAMMA	ΘMR	B1S	A1S	ΘTR
	-1.56	1.40	0.00	-88.60	1.56	90.00	16.26	1.04	-2.23	10.17
	XDOT		ZDOT	U0	V0	W0	VT0			
	0.00		-20.00	0.49	0.55	-19.99	20.00			
	U	W	Q	V	P	R	DC	DB	DA	DP
X	-0.0211	-0.0035	0.3962	-0.0231	-1.7412	-0.1340	0.3031	1.3908	0.0375	0.0069
Z	-0.0555	-0.4638	-0.5473	-0.0939	-0.4939	2.3650	-12.9903	0.1432	0.0071	0.0044
M	0.0004	-0.0038	-0.2790	-0.0001	0.1963	-0.0084	-0.0556	-0.1662	-0.0052	0.0350
Y	0.0124	-0.0248	-2.0341	-0.0710	-0.5372	0.9843	-0.5941	-0.0211	0.9165	1.5990
L'	0.0080	-0.0047	-1.1700	-0.0090	-0.4563	0.0514	-0.0594	-0.0150	0.5304	0.3243
N'	0.0014	0.0020	-0.1422	0.0195	-0.4474	-0.6107	0.7414	-0.0007	0.0389	-0.8172

TABLE IV-4 CONTINUED
AH-IG STABILITY AND CONTROL DERIVATIVES -- US UNITS
(BODY-FIXED FRL AXIS SYSTEM)

CASE 77	60 KT			1200 FT/MIN	SEA LEVEL	8000 LB	MID CG			
	PHI	THETA	PSI	ALPHA	BETA	GAMMA	QMR	BIS	AIS	OTR
	-1.21	-1.04	0.00	-12.42	0.26	11.39	14.78	2.04	-2.36	5.04
	XDOT	ZDOT	UO	VO	WO	VT0				
	99.28	-20.00	98.90	0.46	-21.79	101.27				
	U	W	Q	V	P	R	DC	DB	DA	DP
X	-0.0288	-0.0168	0.9001	-0.0039	-1.5885	-0.1453	-0.3293	1.3478	0.0249	-0.0702
Z	-0.0801	-0.8255	-1.3429	-0.0383	-1.5295	2.2896	-15.0852	2.9720	0.1162	-0.0073
M	0.0024	-0.0053	-0.2421	-0.0002	0.1762	0.0271	0.0013	-0.1671	-0.0039	0.0328
Y	0.0019	-0.0144	-1.5828	-0.1028	-1.2620	1.4504	-0.2879	0.0697	0.9123	1.7111
L*	-0.0030	-0.0053	-0.8093	-0.0111	-0.8628	0.0614	0.0547	0.0366	0.5249	0.3470
N*	-0.0056	0.0022	0.1767	0.0127	-0.4515	-0.9663	0.5757	-0.0029	0.0286	-0.9180

CASE 78	60 KT			600 FT/MIN	SEA LEVEL	8000 LB	MID CG			
	PHI	THETA	PSI	ALPHA	BETA	GAMMA	QMR	BIS	AIS	OTR
	-0.94	-1.73	0.00	-7.40	0.12	5.67	13.62	1.33	-1.96	3.66
	XDOT	ZDOT	UO	VO	WO	VT0				
	100.78	-10.00	100.43	0.21	-13.04	101.27				
	U	W	Q	V	P	R	DC	DB	DA	DP
X	-0.0280	-0.0237	1.3262	-0.0044	-1.5859	-0.1068	-0.5114	1.3368	0.0224	-0.0569
Z	-0.0940	-0.8305	-1.3800	-0.0315	-1.4887	2.0062	-15.0341	2.9918	0.0952	-0.0435
M	0.0022	-0.0038	-0.2838	-0.0000	0.1793	0.0234	0.0153	-0.1627	-0.0036	0.0224
Y	0.0009	-0.0083	-1.5005	-0.1011	-1.6587	1.3689	-0.1724	0.0543	0.8774	1.7224
L*	-0.0032	-0.0048	-0.7398	-0.0081	-1.0780	0.0441	0.0652	0.0361	0.5065	0.3442
N*	-0.0051	-0.0036	0.2435	0.0138	-0.4142	-0.9314	0.4299	0.0177	0.0275	-0.9279

CASE 79	60 KT			-600 FT/MIN	SEA LEVEL	8000 LB	MID CG			
	PHI	THETA	PSI	ALPHA	BETA	GAMMA	QMR	BIS	AIS	OTR
	-0.46	-2.68	0.00	2.98	-0.02	-5.67	11.21	0.07	-1.14	1.24
	XDOT	ZDOT	UO	VO	WO	VT0				
	100.78	10.00	101.14	-0.04	5.27	101.27				
	U	W	Q	V	P	R	DC	DB	DA	DP
X	-0.0260	-0.0300	2.1299	-0.0044	-1.5690	-0.0504	-0.7518	1.3071	0.0223	-0.0556
Z	-0.1176	-0.8387	-1.4554	-0.0187	-1.3228	1.4522	-14.8779	2.9607	0.0820	-0.0413
M	0.0017	-0.0029	-0.3688	-0.0001	0.1836	0.0167	0.0337	-0.1545	-0.0034	0.0117
Y	-0.0003	0.0055	-1.3990	-0.1056	-2.4039	1.2250	0.0816	0.0043	0.8070	1.6969
L*	-0.0032	-0.0015	-0.6538	-0.0004	-1.4719	0.0172	0.1103	0.0237	0.4708	0.3004
N*	-0.0043	-0.0129	0.3274	0.0144	-0.1081	-0.8757	0.1712	0.0598	0.0289	-0.9656

TABLE IV-4 CONTINUED
 AH-IG STABILITY AND CONTROL DERIVATIVES -- US UNITS
 (BODY-FIXED FRL AXIS SYSTEM)

CASE	80	60 KT	-1200 FT/MTN	SPA LEVEL	8000 LB	MID CG				
	PHI	THETA	PSI	ALPHA	BETA	GAMMA	ΘMR	B1S	A1S	ΘTR
	-0.25	-3.13	0.00	8.27	-0.04	-11.39	9.96	-0.70	-0.75	0.28
	XDOT	ZDOT	U0	V0	W0	VT0				
	99.28	20.00	100.22	-0.06	14.56	101.27				
	U	W	Q	V	P	R	DC	DB	DA	DP
X	-0.0253	-0.0331	2.4224	-0.0041	-1.5915	-0.0407	-0.8982	1.2775	0.0157	-0.0271
Z	-0.1298	-0.8280	-1.6502	-0.0127	-1.1302	1.1500	-14.6770	2.8437	0.0726	-0.0732
M	0.0013	-0.0025	-0.3987	-0.0002	0.1904	0.0161	0.0475	-0.1483	-0.0023	0.0061
Y	-0.0009	0.0115	-1.3154	-0.1127	-2.7111	1.1606	0.1937	-0.0122	0.7756	1.7621
L*	-0.0031	-0.0002	-0.5895	0.0048	-1.6257	0.0040	0.1297	0.0194	0.4546	0.3191
N*	-0.0039	-0.0173	0.3971	0.0143	-0.2420	-0.8574	0.0520	0.0736	0.0293	-0.9819

CASE	81	1 KT	LEVEL FLIGHT	10000 FT	8000 LB	MID CG				
	PHI	THETA	PSI	ALPHA	BETA	GAMMA	ΘMR	B1S	A1S	ΘTR
	-1.35	-0.60	0.00	-0.60	0.01	0.00	16.64	-0.63	-2.06	11.76
	XDOT	ZDOT	U0	V0	W0	VT0				
	1.69	0.00	1.69	0.00	-0.02	1.69				
	U	W	Q	V	P	R	DC	DB	DA	DP
X	-0.0197	-0.0145	0.6787	-0.0295	-1.8846	-0.1043	-0.1826	1.2713	-0.0127	-0.1393
Z	-0.0843	-0.2894	0.0314	-0.0681	-0.0823	2.0847	-10.0713	0.1492	-0.0170	-0.0689
M	0.0012	-0.0036	-0.2759	0.0014	0.2124	0.0041	0.0042	-0.1502	0.0029	0.0318
Y	0.0199	-0.0038	-1.5766	-0.0521	-1.3800	0.6319	-0.4797	-0.0817	0.8471	1.1071
L*	0.0108	-0.0045	-1.0303	-0.0104	-0.9499	-0.0361	-0.0429	-0.0455	0.4931	0.1891
N*	-0.0001	-0.0031	-0.1093	0.0132	-0.4646	-0.4977	0.6025	-0.0087	0.0329	-0.6632

CASE	82	60 KT	LEVEL FLIGHT	10000 FT	8000 LB	MID CG				
	PHI	THETA	PSI	ALPHA	BETA	GAMMA	ΘMR	B1S	A1S	ΘTR
	-0.76	-2.06	0.00	-2.06	0.03	0.00	14.02	1.15	-1.98	4.00
	XDOT	ZDOT	U0	V0	W0	VT0				
	101.27	0.00	101.20	0.05	-3.64	101.27				
	U	W	Q	V	P	R	DC	DB	DA	DP
X	-0.0272	-0.0242	2.0576	-0.0054	-1.5324	-0.0812	-0.6203	1.3225	0.0145	-0.0779
Z	-0.0971	-0.6037	-1.6640	-0.0233	-1.0312	1.7378	-10.9987	2.1615	0.0620	-0.0899
M	0.0022	-0.0020	-0.3424	0.0002	0.1722	0.0135	0.0401	-0.1611	-0.0023	0.0198
Y	-0.0010	0.0027	-1.3973	-0.0815	-2.3220	1.0792	-0.0436	0.0077	0.8488	1.3026
L*	-0.0036	0.0001	-0.6311	-0.0069	-1.4781	-0.0261	0.1241	0.0148	0.4930	0.2697
N*	-0.0044	-0.0043	0.4013	0.0102	-0.4493	-0.7188	0.3971	0.0247	0.0289	-0.6897

TABLE IV-4 CONTINUED
AH-IG STABILITY AND CONTROL DERIVATIVES -- US UNITS
(BODY-FIXED FRL AXIS SYSTEM)

CASE	100 KT		LEVEL FLIGHT	10000 FT	8000 LB	MID CG				
	PHI	THETA	PSI	ALPHA	BETA	GAMMA	ΘMR	B1S	A1S	ΘTR
	-0.98	-2.95	0.00	-2.95	0.05	0.00	14.36	3.47	-1.59	3.34
	XDOT		ZDOT	U0	V0	W0	VT0			
	168.78		0.00	168.56	0.15	-8.70	168.78			
	U	W	Q	V	P	R	DC	DB	DA	DP
X	-0.0319	-0.0206	1.9500	-0.0016	-1.5006	-0.0939	-0.6625	1.3228	0.0106	-0.1229
Z	-0.0480	-0.7030	-3.4618	-0.0196	-1.6467	1.9689	-12.5821	4.0208	0.1313	-0.0657
M	0.0025	-0.0036	-0.3795	-0.0006	0.1659	0.0309	0.0345	-0.1710	-0.0018	0.0373
Y	0.0024	-0.0044	-1.4535	-0.1129	-1.9211	1.2764	-0.1154	0.0535	0.8487	1.4494
L*	-0.0013	-0.0021	-0.7019	-0.0049	-1.2254	-0.0109	0.0929	0.0444	0.4949	0.2798
N*	-0.0025	-0.0008	0.2559	0.0108	-0.3518	-0.9469	0.4216	0.0353	0.0328	-0.7904

CASE	12 KT		1200 FT/MIN	10000 FT	8000 LB	MID CG				
	PHI	THETA	PSI	ALPHA	BETA	GAMMA	ΘMR	B1S	A1S	ΘTR
	-1.79	1.61	0.00	-88.39	1.79	90.00	18.06	1.23	-2.46	14.25
	XDOT		ZDOT	U0	V0	W0	VT0			
	0.00		-20.00	0.56	0.62	-19.98	20.00			
	U	W	Q	V	P	R	DC	DB	DA	DP
X	-0.0244	0.0933	0.7494	-0.0246	-1.7957	-0.1002	0.2814	1.4084	0.0362	0.1211
Z	-0.0381	-0.3540	-0.2941	-0.0720	-0.2837	2.2877	-10.1228	0.1407	0.0040	0.0638
M	0.0015	-0.0093	-0.3198	0.0004	0.2091	-0.0367	-0.0529	-0.1727	-0.0080	0.0436
Y	0.0159	-0.0175	-1.8313	-0.0628	-0.7204	0.8145	-0.4045	0.1066	1.0116	1.2522
L*	0.0103	-0.0056	-1.0833	-0.0104	-0.6154	0.0764	0.0523	0.0584	0.5850	0.3843
N*	0.0020	0.0067	-0.2223	0.0156	-0.5543	-0.4923	0.7540	-0.0043	0.0379	-0.4739

CASE	60 KT		1680 FT/MIN	10000 FT	8000 LB	MID CG				
	PHI	THETA	PSI	ALPHA	BETA	GAMMA	ΘMR	B1S	A1S	ΘTR
	-1.68	1.20	0.00	-14.84	0.43	16.05	17.31	4.46	-3.14	15.61
	XDOT		ZDOT	U0	V0	W0	VT0			
	97.32		-28.00	97.89	0.76	-25.94	101.27			
	U	W	Q	V	P	R	DC	DB	DA	DP
X	-0.0251	0.0048	1.0383	-0.0066	-1.6714	-0.3516	0.0777	1.3421	0.0170	-0.1079
Z	-0.0507	-0.5905	-1.9549	-0.0381	-1.1010	2.3081	-10.8286	2.1205	0.0961	-0.0167
M	0.0023	-0.0073	-0.2693	0.0001	0.2257	0.0584	-0.0315	-0.1713	-0.0028	0.0647
Y	-0.0041	-0.0091	-1.6362	-0.0720	-0.9651	0.9447	-0.2724	0.0704	0.9426	0.8745
L*	-0.0038	-0.0012	-0.9597	-0.0117	-0.8144	0.0007	0.1191	0.0254	0.5396	0.2251
N*	-0.0015	0.0072	-0.1614	0.0004	-0.6544	-0.7096	0.7460	-0.0283	0.0260	-0.3970

TABLE IV-4 CONTINUED
AH-IG STABILITY AND CONTROL DERIVATIVES -- US UNITS
(BODY-FIXED FRL AXIS SYSTEM)

CASE	86	60 KT	-1668 FT/MIN	10000 FT	8000 LB	MID CG				
	PHI	THETA	PSI	ALPHA	BETA	GAMMA	ΘMR	B1S	A1S	ΘTR
	-0.12	-3.05	0.00	12.88	-0.03	-15.93	10.67	-0.63	-0.92	-0.17
	XDOT	ZDOT	U0	V0	W0	VT0				
	97.38	27.80	98.72	-0.05	22.58	101.27				
	U	W	Q	V	P	R	DC	DB	DA	DP
X	-0.0243	-0.0527	2.9216	-0.0059	-1.5036	-0.0133	-0.8254	1.2832	0.0247	-0.0127
Z	-0.1226	-0.5194	-1.9342	-0.0102	-0.5360	1.2907	-10.4924	1.9148	0.0686	-0.0413
M	0.0015	-0.0024	-0.4325	-0.0000	0.1845	0.0141	0.0542	-0.1517	-0.0033	0.0030
Y	-0.0028	0.0115	-1.2701	-0.0951	-3.1912	0.8159	0.1793	-0.0147	0.7893	1.3655
L'	-0.0037	0.0017	-0.5245	0.0048	-1.9330	-0.0269	0.1499	0.0129	0.4645	0.2659
N'	-0.0036	-0.0130	0.5228	0.0103	-0.3072	-0.6504	0.1310	0.0579	0.0321	-0.7332

CASE	87	100 KT	-1800 FT/MIN	10000 FT	8000 LB	MID CG				
	PHI	THETA	PSI	ALPHA	BETA	GAMMA	ΘMR	B1S	A1S	ΘTR
	-0.30	-4.19	0.00	6.05	-0.03	-10.24	10.42	0.88	-0.35	-0.43
	XDOT	ZDOT	U0	V0	W0	VT0				
	166.09	30.00	167.84	-0.09	17.79	168.78				
	U	W	Q	V	P	R	DC	DB	DA	DP
X	-0.0292	-0.0308	3.0763	-0.0021	-1.4955	0.0423	-1.0091	1.2839	0.0074	-0.0127
Z	-0.0729	-0.7008	-3.7264	-0.0029	-1.3520	1.1905	-12.5961	3.8585	0.1032	-0.1515
M	0.0017	-0.0023	-0.5121	-0.0004	0.1794	0.0070	0.0692	-0.1545	-0.0016	-0.0035
Y	0.0008	0.0096	-1.3100	-0.1208	-3.0636	1.1239	0.1509	-0.0413	0.7447	1.5003
L'	-0.0013	-0.0010	-0.9066	0.0054	-1.8538	-0.0352	0.0836	0.0226	0.4407	0.2798
N'	-0.0012	-0.0162	-0.5208	0.0104	-0.2471	-0.8685	-0.0086	0.1248	0.0326	-0.8285

CASE	88	1 KT	LEVEL FLIGHT AT SEA LEVEL	8000 LB	FWD CG					
	PHI	THETA	PSI	ALPHA	BETA	GAMMA	ΘMR	B1S	A1S	ΘTR
	-1.10	-4.24	0.00	-4.24	0.08	0.00	14.81	-3.95	-1.75	8.35
	XDOT	ZDOT	U0	V0	W0	VT0				
	1.69	0.00	1.68	0.00	-0.12	1.69				
	U	W	Q	V	P	R	DC	DB	DA	DP
X	-0.0260	-0.0363	0.3930	-0.0332	-1.8028	0.1334	-0.9953	1.2865	0.0366	0.0027
Z	-0.1587	-0.3712	0.0537	-0.0900	0.0751	2.0624	-12.7502	0.1856	-0.0073	-0.0348
M	0.0003	-0.0037	-0.2371	0.0005	0.2227	-0.0004	-0.0057	-0.1545	-0.0051	0.0065
Y	0.0170	-0.0042	-1.5164	-0.0539	-1.7033	0.8395	-0.4460	-0.0070	0.8840	1.5144
L'	0.0084	-0.0054	-0.7764	-0.0079	-0.7091	0.0209	-0.0244	0.0010	0.5100	0.3071
N'	-0.0013	-0.0045	0.4799	0.0162	-0.3826	-0.5378	0.5931	-0.0055	0.0279	-0.8129

TABLE IV-4 CONTINUED
 AH-IG STABILITY AND CONTROL DERIVATIVES -- US UNITS
 (BODY-FIXED FRL AXIS SYSTEM)

CASE	60 KT		LEVEL FLIGHT AT SEA LEVEL				8000 LB	FWD CG		
	PHI	THETA	PSI	ALPHA	BETA	GAMMA	QMR	B1S	A1S	QTR
	-0.65	-5.41	0.00	-5.41	0.06	0.00	12.47	-2.29	-1.50	2.31
		XDOT	ZDOT	U0	V0	W0	VT0			
		101.27	0.00	100.82	0.11	-9.55	101.27			
	U	W	Q	V	P	R	DC	DB	DA	DP
X	-0.0361	-0.0733	1.4202	-0.0058	-1.6761	0.0533	-1.5230	1.4677	0.0378	-0.0501
Z	-0.1438	-0.8313	-1.9710	-0.0228	-1.1990	1.8148	-14.9432	2.8907	0.1070	-0.0312
H	0.0020	-0.0041	-0.3108	-0.0000	0.1854	0.0197	0.0197	-0.1478	-0.0043	0.0170
Y	0.0001	-0.0027	-1.4215	-0.1002	-2.0544	1.3498	-0.0388	0.0293	0.8511	1.7098
L'	-0.0035	-0.0027	-0.4516	-0.0058	-1.2817	0.0264	0.0972	0.0359	0.4917	0.3270
N'	-0.0054	-0.0089	0.8603	0.0153	-0.3357	-0.9392	0.3055	0.0433	0.0229	-0.9493

CASE	100 KT		LEVEL FLIGHT AT SEA LEVEL				8000 LB	FWD CG		
	PHI	THETA	PSI	ALPHA	BETA	GAMMA	QMR	B1S	A1S	QTR
	-0.94	-5.94	0.00	-5.94	0.10	0.00	13.15	0.54	-1.22	1.94
		XDOT	ZDOT	U0	V0	W0	VT0			
		168.78	0.00	167.87	0.29	-17.47	168.78			
	U	W	Q	V	P	R	DC	DB	DA	DP
X	-0.0399	-0.0657	1.2710	-0.0034	-1.7079	-0.0229	-1.5095	1.5131	0.0127	-0.1453
Z	-0.0873	-0.9866	-4.1348	-0.0203	-2.3973	1.9336	-17.5650	5.3521	0.1593	-0.2313
H	0.0028	-0.0082	-0.3815	-0.0007	0.1741	0.0414	-0.0160	-0.1400	-0.0015	0.0325
Y	0.0028	-0.0102	-1.4200	-0.1426	-1.7390	1.8614	-0.1232	0.1299	0.8972	2.0237
L'	-0.0017	-0.0069	-0.5079	-0.0040	-1.0940	0.0482	0.0481	0.1037	0.5195	0.4134
N'	-0.0037	-0.0078	0.6521	0.0162	-0.2990	-1.2517	0.2909	0.0630	0.0215	-1.0895

CASE	1 KT		LEVEL FLIGHT AT SEA LEVEL				8000 LB	AFT CG		
	PHI	THETA	PSI	ALPHA	BETA	GAMMA	QMR	B1S	A1S	QTR
	-1.19	3.43	0.00	3.43	-0.07	0.00	14.82	3.07	-1.75	8.44
		XDOT	ZDOT	U0	V0	W0	VT0			
		1.69	0.00	1.68	-0.00	0.10	1.69			
	U	W	Q	V	P	P	DC	DB	DA	DP
X	-0.0100	0.0107	0.4748	-0.0158	-1.7394	-0.2481	0.7807	1.3538	0.0298	-0.0073
Z	-0.0756	-0.3717	-0.0817	-0.0948	-0.3852	2.0583	-12.7530	0.1789	0.0005	-0.0283
H	0.0004	-0.0031	-0.2542	0.0009	0.2168	0.0093	-0.0041	-0.1639	-0.0040	0.0086
Y	0.0199	-0.0033	-1.4895	-0.0542	-1.3154	0.7915	-0.4189	-0.0078	0.8823	1.5113
L'	0.0100	-0.0050	-1.2631	-0.0082	-0.7122	0.0152	-0.0266	-0.0112	0.5157	0.3163
N'	-0.0009	-0.0047	-0.8258	0.0153	-0.1787	-0.5093	0.5911	-0.0024	0.0453	-0.7844

TABLE IV-4 CONTINUED
 AH-IG STABILITY AND CONTROL DERIVATIVES -- US UNITS
 (BODY-FIXED FRL AXIS SYSTEM)

CASE	60 KT		LEVEL FLIGHT AT SEA LEVEL				8000 LB	AFT CG		
	PHI	THETA	PSI	ALPHA	BETA	GAMMA	ΘMR	B1S	A1S	ΘTR
CASE 92	-0.74	1.35	0.00	1.35	-0.02	0.00	12.37	4.20	-1.58	2.47
	XDOT	ZDOT	U0	V0	W0	VT0				
	101.27	0.00	101.24	-0.03	2.38	101.27				
	U	W	Q	V	P	R	DC	DR	DA	DP
X	-0.0223	0.0239	1.9836	-0.0029	-1.4976	-0.2163	0.3626	1.1445	0.0153	-0.0547
Z	-0.0612	-0.8430	-0.7293	-0.0264	-1.5483	1.6109	-14.9243	3.1282	0.0926	-0.0544
M	0.0018	-0.0017	-0.3416	-0.0000	0.1846	0.0208	0.0358	-0.1713	-0.0028	0.0159
Y	0.0007	-0.0010	-1.3937	-0.1049	-2.0193	1.2412	-0.0333	0.0406	0.8438	1.7320
L'	-0.0027	-0.0034	-0.9038	-0.0028	-1.2649	0.0400	0.0922	0.0336	0.4952	0.3399
N'	-0.0039	-0.0083	-0.3376	0.0132	-0.3647	-0.8571	0.3017	0.0405	0.0410	-0.9272
CASE 93	100 KT		LEVEL FLIGHT AT SEA LEVEL				8000 LB	AFT CG		
	PHI	THETA	PSI	ALPHA	BETA	GAMMA	ΘMR	B1S	A1S	ΘTR
	-1.07	-0.49	0.00	-0.49	0.01	0.00	13.00	5.99	-1.38	2.16
	XDOT	ZDOT	U0	V0	W0	VT0				
	168.78	0.00	168.77	0.03	-1.43	168.78				
	U	W	Q	V	P	R	DC	DR	DA	DP
X	-0.0350	0.0314	1.9127	-0.0004	-1.3536	-0.2008	0.4707	0.9552	0.0152	-0.1015
Z	-0.0103	-0.9939	-1.8670	-0.0232	-2.7065	1.7366	-17.5316	5.9144	0.1638	0.0508
M	0.0020	-0.0031	-0.3890	-0.0007	0.1727	0.0291	0.0337	-0.1937	-0.0028	0.0317
Y	0.0043	-0.0138	-1.4288	-0.1483	-1.6764	1.6775	-0.2020	0.1106	0.8206	1.9210
L'	-0.0007	-0.0091	-0.9355	-0.0004	-1.0694	0.0450	-0.0111	0.0782	0.4833	0.3522
N'	-0.0025	-0.0064	-0.4001	0.0133	-0.3316	-1.1324	0.2782	0.0697	0.0413	-1.0586
CASE 94	1 KT		LEVEL FLIGHT AT SEA LEVEL				6500 LB	MID CG		
	PHI	THETA	PSI	ALPHA	BETA	GAMMA	ΘMR	B1S	A1S	ΘTR
	-1.15	-0.82	0.00	-0.82	0.02	0.00	13.79	-0.83	-1.56	6.85
	XDOT	ZDOT	U0	V0	W0	VT0				
	1.69	0.00	1.69	0.00	-0.02	1.69				
	U	W	Q	V	P	R	DC	DR	DA	DP
X	-0.0147	-0.0158	0.2180	-0.0277	-1.9954	-0.0341	-0.2365	1.3021	0.0290	0.0081
Z	-0.1529	-0.4397	0.0070	-0.1140	-0.1984	2.0457	-15.0322	0.1771	-0.0006	-0.0253
M	-0.0001	-0.0032	-0.1985	-0.0002	0.2075	0.0049	-0.0041	-0.1318	-0.0033	0.0063
Y	0.0174	-0.0038	-1.7124	-0.0574	-0.7837	0.9213	-0.4504	-0.0044	0.8735	1.6766
L'	0.0074	-0.0069	-1.0856	-0.0041	-0.5865	-0.0279	0.3079	-0.0036	0.4843	0.2123
N'	-0.0014	-0.0049	-0.3075	0.0166	-0.3731	-0.5206	0.5496	-0.0024	0.0397	-0.8395

TABLE IV-4 CONTINUED
 AH-IG STABILITY AND CONTROL DERIVATIVES -- US UNITS
 (BODY-FIXED FRL AXIS SYSTEM)

CASE	60 KT		LEVEL FLIGHT AT SEA LEVEL				6500 LB	MID CG		
	PHI	THETA	PSI	ALPHA	BETA	GAMMA	ΘMR	B1S	A1S	ΘTR
	-0.77	-2.52	0.00	-2.52	0.03	0.00	11.59	0.46	-1.32	1.86
	XDOT		ZDOT	U0	V0	W0	VT0			
	101.27		0.00	101.17	0.06	-4.46	101.27			
	U	W	Q	V	P	R	DC	DB	DA	DP
X	-0.0284	-0.0302	1.7191	-0.0043	-1.9431	-0.0599	-0.6573	1.3166	0.0224	-0.0469
Z	-0.1126	-1.0366	-1.8434	-0.0261	-1.6698	1.7649	-18.4451	3.7210	0.1053	-0.0535
H	0.0016	-0.0039	-0.2994	-0.0002	0.1779	0.0182	0.0070	-0.1298	-0.0024	0.0145
Y	0.0014	-0.0026	-1.6937	-0.1213	-1.9917	1.6496	-0.0553	0.0358	0.8440	2.0533
L*	-0.0031	-0.0048	-0.7834	0.0020	-1.2169	-0.0371	0.0900	0.0350	0.4677	0.2365
N*	-0.0043	-0.0084	0.2231	0.0169	-0.3595	-1.0001	0.2603	0.0380	0.0348	-1.0593

CASE	100 KT		LEVEL FLIGHT AT SEA LEVEL				6500 LB	MID CG		
	PHI	THETA	PSI	ALPHA	BETA	GAMMA	ΘMR	B1S	A1S	ΘTR
	-1.21	-3.85	0.00	-3.85	0.08	0.00	12.50	3.02	-1.24	1.74
	XDOT		ZDOT	U0	V0	W0	VT0			
	168.78		0.00	168.40	0.24	-11.34	168.78			
	U	W	Q	V	P	R	DC	DB	DA	DP
X	-0.0396	-0.0112	1.5626	-0.0023	-1.7187	-0.1029	-0.3623	1.2067	0.0019	-0.1325
Z	-0.0496	-1.2222	-3.5875	-0.0255	-3.0585	1.9591	-21.6452	7.0679	0.1491	-0.0134
H	0.0022	-0.0079	-0.3583	-0.0008	0.1610	0.0348	-0.0340	-0.1294	0.0004	0.0364
Y	0.0044	-0.0172	-1.7450	-0.1745	-1.5411	2.1913	-0.2782	0.1016	0.8244	2.2276
L*	-0.0014	-0.0101	-0.9128	0.0061	-0.9891	-0.0824	-0.0095	0.0708	0.4576	0.2035
N*	-0.0027	-0.0051	-0.0462	0.0178	-0.3602	-1.3244	0.3024	0.0437	0.0353	-1.2136

CASE	1 KT		LEVEL FLIGHT AT SEA LEVEL				6500 LB	FWD CG		
	PHI	THETA	PSI	ALPHA	BETA	GAMMA	ΘMR	B1S	A1S	ΘTR
	-1.10	-5.19	0.00	-5.18	0.10	0.00	13.76	-4.90	-1.55	6.79
	XDOT		ZDOT	U0	V0	W0	VT0			
	1.69		0.00	1.68	0.00	-0.15	1.69			
	U	W	Q	V	P	R	DC	DB	DA	DP
X	-0.0318	-0.0478	0.1978	-0.0359	-2.0171	0.1718	-1.4323	1.2739	0.0327	0.0133
Z	-0.2094	-0.4373	0.1292	-0.1106	0.0971	2.0383	-15.0055	0.2014	0.0603	-0.0134
H	-0.0002	-0.0034	-0.1919	-0.0002	0.2114	0.0005	-0.0036	-0.1282	-0.0037	0.0064
Y	0.0157	-0.0042	-1.7299	-0.0572	-0.7957	0.9414	-0.4643	-0.0070	0.8708	1.6717
L*	0.0065	-0.0061	-0.6922	-0.0039	-0.5956	-0.0299	0.0111	0.0019	0.4791	0.2035
N*	-0.0015	-0.0048	0.7407	0.0169	-0.3759	-0.5160	0.5596	-0.0046	0.0314	-0.8540

TABLE IV-4 CONTINUED
 AH-IG STABILITY AND CONTROL DERIVATIVES -- US UNITS
 (BODY-FIXED FRL AXIS SYSTEM)

CASE	60 KT		LEVEL FLIGHT AT SEA LEVEL			6500 LB	FWD CG			
	PHI	THETA	PSI	ALPHA	BETA	GAMMA	ΘMR	B1S	A1S	ΘTR
	-0.72	-6.38	0.00	-6.38	0.08	0.00	11.64	-3.26	-1.27	1.78
	XDOT	ZDOT	UO	VO	WO	VTO				
	101.27	0.00	100.64	0.14	-11.25	101.27				
	U	W	Q	V	P	R	DC	DB	DA	DP
X	-0.0418	-0.0984	1.3057	-0.0058	-1.9453	0.0952	-1.9786	1.5466	0.0321	-0.0644
Z	-0.1714	-1.0271	-2.6776	-0.0237	-1.3500	1.8434	-18.4134	3.5782	0.1099	-0.0107
M	0.0015	-0.0053	-0.2891	-0.0002	0.1788	0.0191	-0.0029	-0.1173	-0.0031	0.0169
Y	0.0005	-0.0029	-1.7138	-0.1190	-2.0236	1.7106	-0.0608	0.0233	0.8400	1.9968
L*	-0.0038	-0.0042	-0.4275	0.0000	-1.2321	-0.0611	0.0910	0.0322	0.4595	0.1990
M*	-0.0051	-0.0083	0.9923	0.0178	-0.3435	-1.0569	0.2640	0.0385	0.0232	-1.0846

CASE	28 KT		2846 FT/MIN	SEA LEVEL	6500 LB	FWD CG				
	PHI	THETA	PSI	ALPHA	BETA	GAMMA	ΘMR	B1S	A1S	ΘTR
	-2.30	4.79	0.00	-85.21	2.29	90.00	17.69	3.40	-2.88	10.88
	XDOT	ZDOT	UO	VO	WO	VTO				
	0.00	-47.44	3.96	1.90	-47.24	47.44				
	U	W	Q	V	P	R	DC	DB	DA	DP
X	-0.0413	0.0283	-0.8945	-0.0019	-1.9446	-0.3005	1.1538	1.5821	0.0304	-0.0051
Z	-0.0441	-0.7525	-1.2336	-0.1037	-0.9787	3.2360	-16.5815	0.2719	0.0806	0.1169
M	-0.0047	-0.0282	-0.3153	-0.0007	0.1687	0.0058	-0.2606	-0.1521	-0.0034	0.0852
Y	0.0056	-0.0448	-2.5310	-0.1177	0.7098	1.6335	-0.9651	-0.0230	1.0240	1.9683
L*	0.0068	-0.0112	-1.5663	-0.0045	0.1288	0.0435	-0.0511	-0.0252	0.5546	0.2529
M*	0.0032	0.0237	-0.5611	0.0304	-0.5722	-0.8814	1.0269	0.0002	0.0335	-0.9771

CASE	60 KT		2880 FT/MIN	SEA LEVEL	6500 LB	FWD CG				
	PHI	THETA	PSI	ALPHA	BETA	GAMMA	ΘMR	B1S	A1S	ΘTR
	-2.22	-1.32	0.00	-29.59	1.10	28.29	17.33	2.59	-3.28	8.03
	XDOT	ZDOT	UO	VO	WO	VTO				
	89.17	-48.00	88.04	1.94	-50.00	101.27				
	U	W	Q	V	P	R	DC	DB	DA	DP
X	-0.0114	0.0274	-0.5900	-0.0049	-1.9726	-0.2487	-0.1420	1.5091	0.0286	-0.1073
Z	-0.0454	-1.0120	-2.1922	-0.0649	-1.8963	3.4846	-18.6822	3.2946	0.2167	0.1276
M	0.0028	-0.0257	-0.0932	-0.0004	0.1516	0.0575	-0.1721	-0.1238	0.0000	0.0806
Y	0.0057	-0.0399	-2.1838	-0.1255	0.3972	2.1776	-0.8661	0.0394	0.9908	1.8965
L*	-0.0039	-0.0095	-1.1296	-0.0144	-0.0481	-0.0465	0.0151	-0.0149	0.5317	0.1961
M*	-0.0069	0.0226	0.0433	0.0280	-0.6192	-1.2807	1.0178	-0.0678	0.0240	-1.0315

TABLE IV-4 CONTINUED
AH-IG STABILITY AND CONTROL DERIVATIVES -- US UNITS
(BODY-FIXED FRL AXIS SYSTEM)

CASE 101		30 KT	-3000 FT/MIN	SEA LEVEL	6500 LB	FWD CG					
PHI	THETA	PSI	ALPHA	BETA	GAMMA	ΘMR	B1S	A1S	ΘTR		
-0.05	-6.52	0.00	83.48	-0.05	-90.00	9.39	-6.42	-0.29	0.28		
XDOT		ZDOT	U0	V0	W0	VT0					
0.00		50.00	5.68	-0.04	49.68	50.00					
U	W	Q	V	P	R	DC	DR	DA	DP		
X	-0.0340	-0.0794	1.6285	-0.0024	-1.3480	0.1615	-1.5851	1.1488	0.0294	0.0562	
Z	-0.0152	-0.7049	-1.5766	0.0477	0.4095	-0.8747	-12.4825	0.0613	0.0087	-0.0339	
M	0.0001	0.0002	-0.2341	-0.0052	0.1966	-0.0270	0.0073	-0.1180	-0.0030	-0.0165	
Y	0.0216	0.0017	-1.8531	-0.0914	-2.1902	1.8810	-0.0089	0.0231	0.7790	1.1635	
L*	0.0100	-0.0031	-0.4762	0.0006	-1.2141	-0.1852	0.0672	0.0147	0.4346	0.2439	
N*	-0.0014	-0.0088	1.1709	0.0284	-0.1035	-1.1199	0.1552	0.0041	0.0300	-0.5863	

CASE 102		60 KT	-1680 FT/MIN	SEA LEVEL	6500 LB	FWD CG					
PHI	THETA	PSI	ALPHA	BETA	GAMMA	ΘMR	B1S	A1S	ΘTR		
-0.10	-8.02	0.00	8.03	-0.01	-16.05	8.10	-6.06	-0.20	-0.50		
XDOT		ZDOT	U0	V0	W0	VT0					
97.32		28.00	100.27	-0.02	14.15	101.27					
U	W	Q	V	P	R	DC	DR	DA	DP		
X	-0.0469	-0.1221	2.4292	-0.0035	-1.8712	0.1023	-2.7063	1.4992	0.0205	-0.0337	
Z	-0.2211	-1.0036	-3.1857	-0.0054	-0.8550	0.8848	-17.9823	3.2389	0.0774	-0.1017	
M	0.0007	-0.0024	-0.3930	-0.0004	0.1871	0.0099	0.0610	-0.1078	-0.0018	0.0045	
Y	0.0009	0.0187	-1.5416	-0.1335	-3.2561	1.5214	0.3156	-0.0440	0.7323	2.0724	
L*	-0.0031	-0.0009	-0.2019	0.0150	-1.8272	-0.0631	0.1056	0.0190	0.4079	0.1996	
N*	-0.0054	-0.0230	1.3448	0.0180	-0.1761	-0.9848	-0.1399	0.0955	0.0255	-1.1163	

CASE 103		1 KT	LEVEL FLIGHT AT SEA LEVEL	6500 LB	AFT CG						
PHI	THETA	PSI	ALPHA	BETA	GAMMA	ΘMR	B1S	A1S	ΘTR		
-1.19	3.59	0.00	3.59	-0.07	0.00	13.79	3.27	-1.56	6.88		
XDOT		ZDOT	U0	V0	W0	VT0					
1.69		0.00	1.68	-0.00	0.11	1.69					
U	W	Q	V	P	R	DC	DR	DA	DP		
X	-0.0069	0.0162	0.2743	-0.0142	-1.9473	-0.2618	0.9600	1.3316	0.0165	-0.0253	
Z	-0.0957	-0.4305	-0.0917	-0.1161	-0.4980	2.0392	-15.0208	0.1701	0.0041	-0.0161	
M	-0.0001	-0.0029	-0.2068	0.0001	0.2955	0.0100	-0.0039	-0.1357	-0.3022	0.0096	
Y	0.0192	-0.0032	-1.6820	-0.0572	-0.7733	0.9150	-0.4144	0.0147	0.8861	1.7208	
L*	0.0084	-0.0057	-1.4450	-0.0041	-0.5757	-0.0143	0.0221	0.0053	0.4973	0.2501	
N*	-0.0012	-0.0049	-0.9516	0.0160	-0.1635	-0.5926	0.5471	0.0004	0.0494	-0.3205	

TABLE IV-4 CONTINUED
 AH-IG STABILITY AND CONTROL DERIVATIVES -- US UNITS
 (BODY-FIXED FRL AXIS SYSTEM)

CASE 104	60 KT			LEVEL FLIGHT AT SEA LEVEL			6500 LB	AFT CG		
	PHI	THETA	PSI	ALPHA	BETA	GAMMA	QMR	B1S	A1S	QTR
	-0.84	1.18	0.00	1.18	-0.02	0.00	11.55	4.15	-1.38	1.96
	XDOT	ZDOT	U0	V0	W0	VT0				
	101.27	0.00	101.25	-0.03	2.08	101.27				
	U	W	Q	V	P	R	DC	DB	DA	DP
X	-0.0241	0.0380	2.0110	-0.0023	-1.6935	-0.1995	0.6608	1.0821	0.0134	-0.0599
Z	-0.0532	-1.0420	-0.9536	-0.0281	-1.9300	1.5917	-18.3907	3.9154	0.0966	-0.0036
M	0.0013	-0.0025	-0.3121	-0.0002	0.1770	0.0172	0.0174	-0.1440	-0.0020	0.0159
Y	0.0024	-0.0036	-1.6652	-0.1250	-1.9487	1.5866	-0.0476	0.0549	0.8360	2.0556
L*	-0.0023	-0.0052	-1.1152	0.0044	-1.1960	-0.0179	0.0916	0.0424	0.4686	0.2401
N*	-0.0035	-0.0078	-0.5378	0.0155	-0.3734	-0.9503	0.2619	0.0399	0.0444	-1.0447

CASE 105	60 KT			3054 FT/MIN			SEA LEVEL	6500 LB	AFT CG		
	PHI	THETA	PSI	ALPHA	BETA	GAMMA	QMR	B1S	A1S	QTR	
	-2.41	6.33	0.00	-23.83	0.98	30.17	17.28	8.31	-3.32	7.98	
	XDOT	ZDOT	U0	V0	W0	VT0					
	87.55	-50.90	92.62	1.72	-40.91	101.27					
	U	W	Q	V	P	R	DC	DB	DA	DP	
X	-0.0306	0.1052	-0.3226	0.0022	-1.5932	-0.6559	2.0027	1.1811	-0.0156	-0.1425	
Z	0.0374	-1.0037	-1.1911	-0.0704	-2.3755	3.1849	-18.6387	3.4621	0.1372	-0.0268	
M	-0.0003	-0.0177	-0.1403	-0.0003	0.1543	0.0410	-0.0836	-0.1710	-0.0016	0.0669	
Y	0.0103	-0.0383	-2.0036	-0.1256	0.4791	2.0579	-0.7544	0.1557	1.0306	2.0968	
L*	-0.0020	-0.0084	-1.6197	-0.0131	0.0268	0.0427	0.0489	0.0283	0.5676	0.3171	
N*	-0.0092	0.0216	-1.1914	0.0161	-0.5787	-1.1493	1.0191	-0.0752	0.0443	-0.9999	

CASE 106	60 KT			-1740 FT/MIN			SEA LEVEL	6500 LB	AFT CG		
	PHI	THETA	PSI	ALPHA	BETA	GAMMA	QMR	B1S	A1S	QTR	
	-0.21	-1.15	0.00	15.49	-0.06	-16.64	8.20	1.72	-0.36	-0.19	
	XDOT	ZDOT	U0	V0	W0	VT0					
	97.03	29.00	97.59	-0.10	27.04	101.27					
	U	W	Q	V	P	R	DC	DB	DA	DP	
X	-0.0170	-0.0192	3.2816	-0.0006	-1.6938	-0.0959	0.1721	1.0717	0.0173	-0.0171	
Z	-0.1031	-0.9997	-1.5097	-0.0123	-1.4092	0.7320	-18.2065	3.6235	0.0873	-0.0214	
M	0.0016	-0.0050	-0.4188	-0.0006	0.1830	0.0113	0.0907	-0.1396	-0.0025	0.0082	
Y	-0.0003	0.0158	-1.5529	-0.1587	-3.1822	1.4251	0.3100	-0.0087	0.7678	2.1377	
L*	-0.0027	0.0005	-0.9117	0.0298	-1.9128	-0.0453	0.1171	0.0341	0.4330	0.2265	
N*	-0.0020	-0.0216	-0.2162	0.0171	-0.2487	-0.9144	-0.1123	0.0929	0.0419	-1.1003	

TABLE IV-4 CONTINUED
AH-IG STABILITY AND CONTROL DERIVATIVES -- US UNITS
(BODY-FIXED FRL AXIS SYSTEM)

CASE 107	1 KT			LEVEL FLIGHT AT SEA LEVEL			9500 LB	MID CG		
	PHI	THETA	PSI	ALPHA	BETA	GAMMA	QMR	B1S	A1S	QTR
	-1.13	-0.61	0.00	-0.61	0.01	0.00	15.81	-0.60	-1.92	10.06
	XDOT		ZDOT	U0	V0	W0	VTO			
	1.69		0.00	1.69	0.00	-0.02	1.69			
	U	W	Q	V	P	R	DC	DB	DA	DP
X	-0.0172	-0.0139	0.5376	-0.0282	-1.6669	-0.0519	-0.1385	1.3160	0.0346	-0.0215
Z	-0.0978	-0.3236	-0.0214	-0.0781	-0.1402	2.0979	-11.1163	0.1762	-0.0042	-0.0324
M	0.0010	-0.0039	-0.2970	0.0013	0.2455	0.0057	-0.0053	-0.1907	-0.0052	0.0115
Y	0.0194	-0.0036	-1.1864	-0.0524	-1.1775	0.7215	-0.4376	-0.0279	0.8788	1.3595
L*	0.0110	-0.0047	-0.9894	-0.0118	-0.8294	0.0393	-0.0645	-0.0195	0.5428	0.3706
N*	-0.0008	-0.0042	-0.1273	0.0153	-0.3701	-0.5345	0.6166	-0.0046	0.0334	-0.7660

CASE 108	60 KT			LEVEL FLIGHT AT SEA LEVEL			9500 LB	MID CG		
	PHI	THETA	PSI	ALPHA	BETA	GAMMA	QMR	B1S	A1S	QTR
	-0.65	-2.03	0.00	-2.03	0.02	0.00	13.28	1.02	-1.78	3.07
	XDOT		ZDOT	U0	V0	W0	VTO			
	101.27		0.00	101.20	0.04	-3.59	101.27			
	U	W	Q	V	P	R	DC	DB	DA	DP
X	-0.0267	-0.0255	1.7046	-0.0049	-1.4296	-0.0915	-0.6044	1.3184	0.0277	-0.0582
Z	-0.1007	-0.6992	-1.1139	-0.0237	-1.2391	1.7352	-12.5557	2.4935	0.0913	-0.0611
M	0.0026	-0.0026	-0.3635	0.0002	0.1991	0.0237	0.0407	-0.1929	-0.0048	0.0191
Y	-0.0006	0.0012	-1.2431	-0.0893	-2.0538	1.0505	-0.0285	0.0247	0.8480	1.5053
L*	-0.0034	-0.0015	-0.6337	-0.0097	-1.3481	0.0652	0.0975	0.0290	0.5255	0.4084
N*	-0.0051	-0.0081	0.3310	0.0126	-0.3433	-0.8298	0.3471	0.0398	0.0274	-0.8478

CASE 109	100 KT			LEVEL FLIGHT AT SEA LEVEL			9500 LB	MID CG		
	PHI	THETA	PSI	ALPHA	BETA	GAMMA	QMR	B1S	A1S	QTR
	-0.86	-2.97	0.00	-2.97	0.04	0.00	13.72	3.27	-1.42	2.43
	XDOT		ZDOT	U0	V0	W0	VTO			
	168.78		0.00	168.55	0.13	-8.74	168.78			
	U	W	Q	V	P	R	DC	DB	DA	DP
X	-0.0326	-0.0222	1.6797	-0.0018	-1.3470	-0.1147	-0.6621	1.3013	0.0185	-0.0902
Z	-0.0599	-0.8265	-2.6718	-0.0193	-2.1194	1.8505	-14.6720	4.6541	0.1615	-0.1001
M	0.0031	-0.0048	-0.4252	-0.0007	0.1821	0.0407	0.0351	-0.2035	-0.0041	0.0326
Y	0.0025	-0.0071	-1.2419	-0.1253	-1.8065	1.4416	-0.1319	0.0810	0.8510	1.6946
L*	-0.0014	-0.0057	-0.6749	-0.0090	-1.1904	0.0310	0.0262	0.0678	0.5275	0.4465
N*	-0.0035	-0.0072	0.2342	0.0131	-0.3599	-1.0906	0.1195	0.0624	0.0271	-0.9684

TABLE IV-4 CONTINUED
AH-IG STABILITY AND CONTROL DERIVATIVES-- US UNITS
(BODY-FIXED FRL AXIS SYSTEM)

CASE 110		1 KT		LEVEL FLIGHT AT SEA		LFVFL	9500 LB	FWD CG		
PHI	THETA	PSI	ALPHA	BETA	GAMMA	ΘMR	B1S	A1S	ΘTR	
-1.10	-3.10	0.00	-3.10	0.06	0.00	15.82	-2.84	-1.94	10.02	
	XDOT	ZDOT	U0	V0	W0	VT0				
	1.69	0.00	1.69	0.00	-0.09	1.69				
	U	W	Q	V	P	R	DC	DB	DA	DP
X	-0.0225	-0.0269	0.5260	-0.0314	-1.6709	0.0815	-0.6286	1.3016	0.0411	-0.0054
Z	-0.1211	-0.3229	0.0220	-0.0761	0.0024	2.0924	-11.1065	0.1813	-0.0048	-0.0256
H	0.0009	-0.0041	-0.2923	0.0013	0.2461	0.0004	-0.0082	-0.1886	-0.0066	0.0079
Y	0.0186	-0.0039	-1.3916	-0.0521	-1.1611	0.7531	-0.4318	-0.0113	0.8884	1.3901
L*	0.0105	-0.0048	-0.8521	-0.0115	-0.8208	0.0525	-0.0533	-0.0058	0.5467	0.3865
N*	-0.0009	-0.0042	0.2552	0.0156	-0.3714	-0.5421	0.6243	-0.0051	0.0275	-0.7743

CASE 111		60 KT		LEVEL FLIGHT AT SEA		LEVEL	9500 LB	FWD CG		
PHI	THETA	PSI	ALPHA	BETA	GAMMA	ΘMR	B1S	A1S	ΘTR	
-0.62	-4.28	0.00	-4.28	0.05	0.00	13.32	-1.08	-1.75	3.03	
	XDOT	ZDOT	U0	V0	W0	VT0				
	101.27	0.00	100.99	0.08	-7.56	101.27				
	U	W	Q	V	P	R	DC	DB	DA	DP
X	-0.0324	-0.0520	1.4880	-0.0061	-1.5011	-0.0160	-1.1431	1.3797	0.0266	-0.0981
Z	-0.1228	-0.6954	-1.4891	-0.0229	-1.1369	1.7624	-12.5861	2.3938	0.0802	-0.1178
H	0.0026	-0.0033	-0.3468	0.0002	0.2029	0.0255	0.0384	-0.1821	-0.0041	0.0253
Y	-0.0907	0.0012	-1.2504	-0.0882	-2.0652	1.0936	-0.0328	0.0221	0.8534	1.5006
L*	-0.0036	-0.0013	-0.5116	-0.0105	-1.3536	0.0653	0.0994	0.0302	0.5272	0.4069
N*	-0.0055	-0.0080	0.6846	0.0133	-0.3339	-0.8549	0.3497	0.0402	0.0211	-0.8574

CASE 112		7 FT		720 FT/MIN		SEA LEVEL	9500 LB	FWD CG		
PHI	THETA	PSI	ALPHA	BETA	GAMMA	ΘMR	B1S	A1S	ΘTR	
-1.33	-2.27	0.00	-92.28	1.33	90.00	16.65	-2.18	-2.21	11.27	
	XDOT	ZDOT	U0	V0	W0	VT0				
	0.00	-12.00	-0.48	0.28	-11.99	12.00				
	U	W	Q	V	P	R	DC	DB	DA	DP
X	-0.0222	-0.0180	0.6403	-0.0194	-1.7127	-0.0216	-0.5298	1.2638	-0.0020	-0.1310
Z	-0.0663	-0.3644	-0.4324	-0.0761	-0.0939	2.2411	-11.1729	0.1435	0.0032	0.0214
H	0.0039	-0.0065	-0.3061	0.0018	0.2502	0.0021	-0.0160	-0.1782	0.0024	0.0622
Y	0.0181	-0.0207	-1.9058	-0.0604	-1.0161	0.7526	-0.6147	-0.1084	0.8476	1.2447
L*	0.0092	-0.0045	-0.9999	-0.0131	-0.7447	0.0322	-0.1317	-0.0698	0.5239	0.2932
N*	0.0059	0.0055	0.1912	0.0166	-0.4377	-0.5872	0.7057	-0.0080	0.0270	-0.7975

TABLE IV-4 CONTINUED
AH-IG STABILITY AND CONTROL DERIVATIVES -- US UNITS
(BODY-FIXED FRL AXIS SYSTEM)

CASE 113	61 KT		1884 FT/MIN		SEA LEVEL		9500 LB		FWD CG	
	PHI	THETA	PSI	ALPHA	BETA	GAMMA	ΘMR	B1S	A1S	ΘTR
	-1.46	-1.99	0.00	-19.79	0.49	17.81	17.03	1.51	-3.09	8.42
	XDOT		ZDOT	U0	V0	W0	VT0			
	97.74		-31.40	96.59	0.88	-34.76	102.66			
	U	W	Q	V	P	R	DC	DB	DA	DP
X	-0.0257	-0.0210	0.8665	-0.0055	-1.4479	-0.0596	-0.7085	1.5530	0.0807	-0.0095
Z	-0.0748	-0.6817	-1.2957	-0.0428	-1.2851	2.6342	-12.7832	2.5471	0.2040	0.1905
M	0.0031	-0.0109	-0.1496	-0.0002	0.1724	0.0475	-0.1080	-0.1752	-0.0095	0.0467
Y	0.0017	-0.0180	-1.4645	-0.0949	-1.0042	1.3729	-0.3756	0.0894	0.9706	1.5631
L*	-0.0031	-0.0057	-0.7384	-0.0189	-0.7443	0.1455	0.0312	0.0472	0.5887	0.4524
M*	-0.0063	0.0082	0.3551	0.0114	-0.4980	-0.9850	0.7810	-0.0155	0.0242	-0.8333

CASE 114	60 KT		-1590 FT/MIN		SEA LEVEL		9500 LB		FWD CG	
	PHI	THETA	PSI	ALPHA	BETA	GAMMA	ΘMR	B1S	A1S	ΘTR
	-0.08	-5.32	0.00	9.85	-0.01	-15.17	10.07	-2.93	-0.70	-0.37
	XDOT		ZDOT	U0	V0	W0	VT0			
	97.74		26.50	99.77	-0.03	17.33	101.27			
	U	W	Q	V	P	R	DC	DB	DA	DP
X	-0.0309	-0.0571	2.1688	-0.0051	-1.4435	0.0265	-1.4038	1.3340	0.0290	-0.0360
Z	-0.1478	-0.6651	-1.8188	-0.0099	-0.6924	1.1779	-12.0629	2.1643	0.0814	-0.0922
M	0.0017	-0.0022	-0.4316	-0.0001	0.2083	0.0177	0.0678	-0.1720	-0.0042	0.0065
Y	-0.0015	0.0123	-1.1178	-0.0994	-2.7483	0.9357	0.2261	-0.0116	0.7840	1.5546
L*	-0.0034	0.0017	-0.4174	0.0001	-1.7378	0.0327	0.1553	0.0165	0.4897	0.4003
M*	-0.0050	-0.0176	0.7914	0.0130	-0.1924	-0.7900	0.0550	0.0739	0.0220	-0.9032

CASE 115	1 KT		LEVEL FLIGHT AT SEA LEVEL		9500 LB		AFT CG			
	PHI	THETA	PSI	ALPHA	BETA	GAMMA	ΘMR	B1S	A1S	ΘTR
	-1.18	2.60	0.00	2.60	-0.05	0.00	15.83	2.27	-1.90	10.11
	XDOT		ZDOT	U0	V0	W0	VT0			
	1.69		0.00	1.69	-0.00	0.08	1.69			
	U	W	Q	V	P	R	DC	DB	DA	DP
X	-0.0133	0.0029	0.5855	-0.0201	-1.6254	-0.2044	0.5129	1.3613	0.0401	0.0000
Z	-0.0685	-0.3233	-0.0603	-0.0799	-0.3217	2.0868	-11.1129	0.1792	-0.0016	-0.0324
M	0.0010	-0.0036	-0.3121	0.0015	0.2379	0.0050	-0.0087	-0.2023	-0.0088	0.0001
Y	0.0215	-0.0020	-1.2628	-0.0515	-1.0841	0.8049	-0.3144	0.0899	0.9576	1.6047
L*	0.0123	-0.0030	-1.0693	-0.0112	-0.7636	0.1064	0.0100	0.0563	0.5992	0.5415
M*	-0.0006	-0.0042	-0.6097	0.0149	-0.3619	-0.5155	0.6183	0.0036	0.0468	-0.7380

TABLE IV-4 CONCLUDED
AH-IG STABILITY AND CONTROL DERIVATIVES -- US UNITS
(BODY-FIXED FRL AXIS SYSTEM)

CASE	116	60 KT	LEVEL FLIGHT AT SEA LEVEL	9500 LB	AFT CG					
	PHI	THETA	PSI	ALPHA	BETA	GAMMA	ΘNR	BIS	AIS	ΘTR
	-0.69	0.82	0.00	0.92	-0.01	0.00	13.24	3.71	-1.81	3.13
	XDOT	ZDOT	UO	VO	WO	VT0				
	101.27	0.00	101.26	-0.02	1.44	101.27				
	U	W	Q	V	P	R	DC	DB	DA	DP
X	-0.0223	0.0385	1.9199	-0.0037	-1.3469	-0.2010	0.0622	1.2101	0.0145	-0.0545
Z	-0.0721	-0.7035	-0.6562	-0.0251	-1.3997	1.6585	-12.5387	2.5846	0.0760	-0.0708
M	0.0024	-0.0016	-0.3831	0.0002	0.1979	0.0244	0.0470	-0.2040	-0.0036	0.0177
Y	-0.0003	0.0010	-1.2315	-0.0912	-2.0461	1.0089	-0.0240	0.0275	0.8390	1.5121
L'	-0.0031	-0.0018	-0.7796	-0.0086	-1.3447	0.0661	0.0958	0.0259	0.5230	0.4127
N'	-0.0046	-0.0081	-0.1207	0.0116	-0.3563	-0.7989	0.3442	0.0389	0.0352	-0.8382

CASE	117	60 KT	1932 FT/HIN	SEA LEVEL	9500 LB	AFT CG					
	PHI	THETA	PSI	ALPHA	BETA	GAMMA	ΘNR	BIS	AIS	ΘTR	
	-1.53	2.74	0.00	-15.79	0.42	18.54	16.98	5.58	-3.16	8.50	
	XDOT	ZDOT	UO	VO	WO	VT0					
	96.01	-32.20	97.44	0.74	-27.56	101.27					
	U	W	Q	V	P	R	DC	DB	DA	DP	
X	-0.0287	0.0198	0.8285	-0.0015	-1.3289	-0.3572	0.4708	1.2623	0.0139	-0.1152	
Z	-0.0355	-0.6825	-0.9914	-0.0453	-1.6084	2.3850	-12.6454	2.4730	0.1072	-0.0513	
M	0.0033	-0.0053	-0.2737	-0.0001	0.1923	0.0391	0.0091	-0.2211	-0.0049	0.0558	
Y	0.0032	-0.0172	-1.4343	-0.0934	-1.0199	1.2542	-0.3681	0.0979	0.9550	1.5679	
L'	-0.0023	-0.0056	-0.9856	-0.0182	-0.7520	0.1410	0.0185	0.0434	0.5871	0.4652	
N'	-0.0067	0.0079	-0.3513	0.0093	-0.5055	-0.9097	0.7545	-0.0260	0.0329	-0.8231	

CASE	118	60 KT	-1728 FT/HIN	SEA LEVEL	9500 LB	AFT CG					
	PHI	THETA	PSI	ALPHA	BETA	GAMMA	ΘNR	BIS	AIS	ΘTR	
	-0.09	-0.60	0.00	15.92	-0.02	-16.52	9.90	1.96	-0.75	-0.36	
	XDOT	ZDOT	UO	VO	WO	VT0					
	97.02	28.80	97.38	-0.04	27.78	101.27					
	U	W	Q	V	P	R	DC	DB	DA	DP	
X	-0.0161	-0.0106	2.6842	-0.0031	-1.3238	-0.1200	-0.1197	1.1672	0.0166	-0.0038	
Z	-0.1026	-0.6324	-1.1033	-0.0136	-0.9388	1.1007	-12.1262	2.3215	0.0802	-0.0507	
M	0.0021	-0.0050	-0.4657	-0.0002	0.2041	0.0189	0.0871	-0.1941	-0.0040	0.0020	
Y	-0.0025	0.0111	-1.1458	-0.1135	-2.7563	0.8646	0.2233	-0.0263	0.7687	1.5381	
L'	-0.0036	0.0027	-0.6909	0.0002	-1.7502	0.0245	0.1534	0.0079	0.4856	0.3947	
N'	-0.0032	-0.0174	-0.0103	0.0122	-0.2278	-0.7448	0.0559	0.0775	0.0381	-0.8782	

TABLE IV-5
AH-IG TRANSFER FUNCTION FACTORS

CASE 56 -40KT SCAS OFF

DENOMINATOR: (0) (.343) (1.11) [-.812;.281] [-.380;.358] [-.816;.971] <.00363>

CONTROL NUMERATORS:

PHI/DA .477 (0) (-.484) (.958) [-.304;.334] [.812;.622] <-.00956>
THE/DB -.154 (0) (.00490) (1.30) [-.818;.282] [.981;.727] <-.415E-4>
PSI/DP -.818 (.386) [-.0141;.283] [-.371;.362] [.863;1.03] <-.00352>

PHI/DB -.0711 (0) (.0488) (-.271) (-.866) (1.03) [-.394;1.09] <-.00100>
THE/DA .0795 (0) (.0134) [-.822;.254] [.992;.799] <.442E-4>

PHI/DA ;THE/DB -.0741 (0) (.00521) (-.475) [.999;.814] <.000121>
PHI/DA ;PSI/DP -.402 (.0243) [-.285;.352] [.835;.612] <-.000455>
THE/DB ;PSI/DP .125 (.00461) (.600) (1.28) [-.0345;.292] <.378E-4>

PHI/DB ;PSI/DP .0679 (.0234) [-.438;.129] [-.311;1.33] <.465E-4>
PHI/DP ;THE/DB -.0558 (0) (.00459) (.498) [.279;.795] <-.806E-4>
PHI/DC ;THE/DB .0234 (0) (.00475) (.890) [-.622;1.21] <.000144>

THE/DA ;PSI/DP -.0663 (.0248) (.643) [.0743;.254] <-.680E-4>
THE/DP ;PHI/DA -.0159 (0) (.0248) (.450) [-.305;.897] <-.000143>
THE/DC ;PHI/DA -.0128 (0) (.0135) (-.697) (.892) (2.19) <.000237>

PSI/DA ;THE/DB -.00532 (.00518) (.734) (1.40) [-.417;1.44] <-.590E-4>
PSI/DB ;PHI/DA -.0112 (.0237) (.239) (-.368) [.564;2.27] <.000120>
XD/DB ;PHI/DA .598 (0) (-.476) (.751) (.868) [-.0174;2.01] <-.747>

YD/DA ;THE/DB -.128 (.00518) (-.496) [-.999;.810] [-.00188;4.30] <.00398>
ZD/DB ;PHI/DA -.871 (0) (-.0973) (-.477) (.961) [-.0443;1.99] <-.154>
XD/DC ;PHI/DA .0519 (0) (-.687) (.899) (2.31) [.000225;2.76] <-.563>

YD/DP ;THE/DB -.248 (.00461) (.486) [.338;.777] [.0896;2.76] <-.00255>
ZD/DC ;PHI/DA -6.44 (0) (.0484) (-.527) (.957) [.0893;.579] <.0529>

PHI/DA ;THE/DB ;PSI/DP .0620 (.00387) (.0243) (.682) <.399E-5>
PHI/DC ;THE/DB ;PSI/DP .0359 (.00428) (.0224) <.345E-5>
THE/DC ;PHI/DA ;PSI/DP .0166 (.00893) (.0244) (1.53) <.551E-5>

PSI/DC ;PHI/DA ;THE/DB -.0272 (.00274) (.0279) (.929) <-.193E-5>
XD/DB ;PHI/DA ;PSI/DP -.502 (.0244) (.673) [-.0166;2.01] <-.0331>
YD/DA ;THE/DB ;PSI/DP .112 (.00384) (.682) [-.00314;4.21] <.00521>

ZD/DC ;PHI/DA ;THE/DB .978 (0) (.0116) (-.456) (.871) <-.00448>
ZD/DC ;PHI/DA ;PSI/DP 5.43 (.0264) (.122) [.0410;.556] <.00542>
XD/DC ;PHI/DA ;THE/DB .00803 (0) (-.818) (.914) (1.89) <-.0114>

XD/DC ;PHI/DA ;PSI/DP -.0708 (.0234) (1.62) [.000932;2.67] <-.0190>
YD/DP ;PHI/DA ;THE/DB -.0728 (.00387) (.664) [.0451;1.20] <-.000269>
ZD/DB ;PHI/DA ;PSI/DP .733 (.0244) (-.0917) [.0429;1.98] <-.00642>

ZD/DC ;PHI/DA ;THE/DB ;PSI/DP -.808 (.00609) (.0254) <-.000125>
XD/DC ;PHI/DA ;THE/DB ;PSI/DP -.00976 (.0210) (1.14) <-.000234>

TABLE IV-5 CONTINUED
AH-IG TRANSFER FUNCTION FACTORS

CASE 57 -20KT SCAS OFF

DENOMINATOR: (0) (.295) (.892) [-.508; .338] [-.434; .495] [.887; .807] <.00479>

CONTROL NUMERATORS:

PHI/DA .510 (0) (-.352) (.441) (.566) (.808) [-.432; .436] <-.00688>
THE/DB -.175 (0) (-.0125) (1.10) [-.525; .375] [.956; .518] <.904E-4>
PSI/DP -.770 (.279) [-.0720; .329] [-.413; .471] [.904; .926] <-.00442>

PHI/DB .161 (0) (.171) (-.447) (.840) [-.113; .662] <-.00454>
THE/DA -.0176 (0) (.00267) (.498) (.712) (-4.57) [-.497; .276] <.580E-5>

PHI/DA ;THE/DB -.0891 (0) (-.00998) (-.368) (.502) (.757) <-.000124>
PHI/DA ;PSI/DP -.405 (.0160) (.402) (.629) [-.408; .437] <-.000312>
THE/DB ;PSI/DP .134 (-.0228) (.381) (1.03) [-.0770; .351] <-.000148>

PHI/DB ;PSI/DP -.105 (.0172) (.156) [-.234; .697] <-.000137>
PHI/DP ;THE/DB -.0630 (0) (-.0221) (.304) [.339; .608] <.000157>
PHI/DC ;THE/DB .0111 (0) (-.0111) (.628) [-.807; 1.58] <-.000193>

THE/DA ;PSI/DP .0156 (.0487) (.476) (-4.19) [-.0756; .263] <-.000105>
THE/DP ;PHI/DA -.0223 (0) (.0542) (.521) [-.165; .413] <-.000107>
THE/DC ;PHI/DA -.0153 (0) (-.00456) (.485) (-.698) (.958) <-.227E-4>

PSI/DA ;THE/DB -.00639 (-.0100) (.487) (1.24) [-.657; 1.77] <.000122>
PSI/DB ;PHI/DA -.00413 (.0139) (.276) (-.641) (1.56) (6.27) <.992E-4>
XD/DB ;PHI/DA .710 (0) (-.366) (.514) (.760) [.000196; 1.99] <-.405>

YD/DA ;THE/DB -.156 (-.0100) (-.382) (.504) (.748) [.00647; 4.27] <-.00411>
ZD/DB ;PHI/DA -.411 (0) (-.411) (-.428) (.807) [.00905; 1.90] <-.210>
XD/DC ;PHI/DA .112 (0) (.496) (-.652) (.956) [.0945; 2.13] <-.157>

YD/DP ;THE/DB -.276 (-.0224) (.299) [-.355; .608] [.0653; 2.71] <.00499>
ZD/DC ;PHI/DA -6.25 (0) (.285) (-.308) (.809) [-.341; .371] <.0611>

PHI/DA ;THE/DB ;PSI/DP .0707 (-.0138) (.0158) (.466) <-.718E-5>
PHI/DC ;THE/DB ;PSI/DP .0216 (-.0101) (.0129) (1.50) <-.424E-5>
THE/DC ;PHI/DA ;PSI/DP .0229 (.0173) (-.0394) (.387) <-.604E-5>

PSI/DC ;PHI/DA ;THE/DB -.0430 (-.0109) (.0206) (.567) <.548E-5>
XD/DB ;PHI/DA ;PSI/DP -.563 (.0161) (.480) [.000128; 1.99] <-.0173>
YD/DA ;THE/DB ;PSI/DP .130 (-.0141) (.465) [-.00247; 4.18] <-.0148>

ZD/DC ;PHI/DA ;THE/DB 1.08 (0) (-.00687) (-.350) (.692) <.00180>
ZD/DC ;PHI/DA ;PSI/DP 4.98 (.0179) (.439) [-.313; .405] <.00643>
XD/DC ;PHI/DA ;THE/DB .00180 (0) (.158) (.993) (-5.30) <-.00150>

XD/DC ;PHI/DA ;PSI/DP -.164 (.0137) (.382) [.0981; 2.09] <-.00372>
YD/DP ;PHI/DA ;THE/DB -.0843 (-.0136) (.445) [.0404; .689] <.000242>
ZD/DB ;PHI/DA ;PSI/DP .326 (.0163) (-.456) [.00633; 1.86] <-.00836>

ZD/DC ;PHI/DA ;THE/DB ;PSI/DP -.850 (.0177) (-.0207) <.000310>
XD/DC ;PHI/DA ;THE/DB ;PSI/DP -.00330 (.0222) (-3.41) <.000249>

TABLE IV-5 CONTINUED
AH-IG TRANSFER FUNCTION FACTORS

CASE 57 -20KT SCAS ON

DENOMINATOR: (0) (.0620) (.174) (.253) (.465) (.760) (2.93) [-.0690; .182] [-.519; .186] [-.644; 2.22] [-.727; 3.42] <.000186>

CONTROL NUMERATORS:

PHI/DA	.510	(0)	(.0644)	(-.122)	(.147)	(.253)	(.466)	(.761)	(3.04)	(5.75)	[-.125; .179]	[.641; 2.20]	<-.000142>
THE/DB	-.175	(0)	(-.0169)	(.0551)	(.0699)	(.174)	(.464)	(2.59)	[-.435; .171]	[.646; 2.22]	[.711; 3.36]	<.190E-5>	
PSI/DP	-.770	(.0794)	(-.135)	(.253)	(.465)	(.760)	(2.93)	(4.01)	[-.319; .166]	[-.0485; .179]	[.741; 3.52]	<-.942E-4>	
PHI/DB	-.155	(0)	(.0699)	(-.185)	(.368)	(1.00)	(2.59)	[.972; .164]	[-.193; .636]	[.643; 2.14]	<-.950E-4>		
THE/DA	-.0176	(0)	(.06464)	(.0644)	(.137)	(.476)	(-4.52)	(5.75)	[-.164; .312]	[.999; .428]	[.630; 2.24]	<.834E-6>	
PHI/DA ; THE/DB	-.0891	(0)	(-.00977)	(.0644)	(.0699)	(-.132)	(.147)	(.465)	(2.59)	(5.75)	[.642; 2.20]	<-.256E-5>	
PHI/DA ; PSI/DP	-.405	(.0160)	(.0644)	(.0794)	(.253)	(.466)	(.761)	(3.04)	(4.01)	(5.75)	[-.108; .179]	<-.665E-5>	
THE/DB ; PSI/DP	.134	(-.0228)	(.0699)	(.0794)	(.134)	(.465)	(2.59)	(4.01)	[-.241; .156]	[.747; 3.45]	<-.316E-5>		
PHI/DB ; PSI/DP	-.105	(.0172)	(.0699)	(.0794)	(.156)	(.370)	(1.00)	(2.59)	(4.01)	[-.234; .697]	<-.293E-5>		
PHI/DB ; THE/DB	-.0630	(0)	(-.0220)	(.0699)	(.0794)	(.485)	(2.59)	(4.01)	[-.599; .223]	[.630; 1.32]	<.334E-5>		
PHI/DC ; THE/DB	.0111	(0)	(-.0111)	(.0699)	(.163)	(-.225)	(.366)	(.939)	(2.59)	(-5.46)	[.845; 1.63]	<-.406E-5>	
THE/DA ; PSI/DP	.0156	(.0487)	(.0644)	(.0794)	(.417)	(.435)	(.476)	(4.01)	(-4.19)	(5.75)	[-.0756; .263]	<-.224E-5>	
THE/DP ; PHI/DA	-.0223	(0)	(.0644)	(.0743)	(.0794)	(.466)	(4.01)	(5.75)	[.757; .174]	[.922; .905]	<-.225E-5>		
THE/DC ; PHI/DA	-.0153	(0)	(-.00387)	(.0644)	(.152)	(-.259)	(.353)	(5.75)	[.999; .438]	[.591; 2.72]	<-.435E-6>		
PSI/DA ; THE/DB	-.00639	(-.0100)	(.0644)	(.0699)	(.487)	(.541)	(.588)	(1.24)	(2.59)	(5.75)	[-.657; 1.77]	<.260E-5>	
PSI/DB ; PHI/DA	-.00413	(.0139)	(.0644)	(.0699)	(.263)	(.500)	(-.671)	(.852)	(1.20)	(2.59)	(5.75)	(5.97)	<.212E-5>
XD/DB ; PHI/DA	.710	(0)	(.0644)	(.0699)	(-.129)	(.148)	(.480)	(2.59)	(5.75)	[.000731; 1.99]	[.642; 2.20]	<-.00841>	
YD/DA ; THE/DB	-.156	(-.00993)	(.0644)	(.0699)	(.142)	(-.144)	(.465)	(2.59)	(5.75)	[.635; 2.21]	[.0150; 4.26]	<-.876E-4>	
ZD/DB ; PHI/DA	-.411	(0)	(.0644)	(.0699)	(-.138)	(.150)	(-.454)	(2.59)	(5.75)	[.0203; 1.87]	[.635; 2.19]	<-.00436>	
XD/DC ; PHI/DA	.112	(0)	(.0644)	(.171)	(-.209)	(.620)	(5.75)	[.942; .291]	[.0172; 2.52]	[.607; 2.62]	<-.00340>		
YD/DP ; THE/DB	-.276	(-.0223)	(.0699)	(.0794)	(.469)	(2.59)	(4.01)	[.540; .197]	[.328; 1.21]	[.423; 3.34]	<.000107>		
ZD/DC ; PHI/DA	-6.25	(0)	(.0644)	(-.0764)	(.123)	(.246)	(.783)	(2.96)	(5.75)	[-.179; .140]	[.629; 2.18]	<.00116>	
PHI/DA ; THE/DB ; PSI/DP	.0707	(-.0138)	(.0158)	(.0644)	(.0699)	(.0794)	(.466)	(2.59)	(4.01)	(5.75)	<-.153E-6>		
PHI/DC ; THE/DB ; PSI/DP	.0216	(-.0101)	(.0129)	(.0699)	(.0794)	(.370)	(1.00)	(1.50)	(2.59)	(4.01)	<-.905E-7>		
THE/DC ; PHI/DA ; PSI/DP	.0229	(.0173)	(-.0394)	(.0644)	(.0794)	(.387)	(.417)	(.435)	(4.01)	(5.75)	<-.129E-6>		
PSI/DC ; PHI/DA ; THE/DB	-.0430	(-.0109)	(.0206)	(.0644)	(.0699)	(.541)	(.567)	(.588)	(2.59)	(5.75)	<.117E-6>		
XD/DB ; PHI/DA ; PSI/DP	-.563	(.0161)	(.0644)	(.0699)	(.0794)	(.480)	(2.59)	(4.01)	(5.75)	[.000127; 1.99]	<-.000369>		
YD/DA ; THE/DB ; PSI/DP	.130	(-.0141)	(.0644)	(.0699)	(.0794)	(.465)	(2.59)	(4.01)	(5.75)	[-.00247; 4.18]	<-.000316>		
ZD/DC ; PHI/DA ; THE/DB	1.08	(0)	(-.00606)	(.0644)	(.0699)	(-.123)	(.133)	(2.59)	(5.75)	[.627; 2.18]	<.342E-4>		
ZD/DC ; PHI/DA ; PSI/DP	4.98	(.0179)	(.0644)	(.0794)	(.244)	(.783)	(2.93)	(4.01)	(5.75)	[-.0799; .153]	<.000137>		
XD/DC ; PHI/DA ; THE/DB	.00180	(0)	(.0644)	(.0699)	(2.59)	(-4.51)	(5.75)	[.682; .0841]	[.715; 3.03]	<-.354E-4>			
XD/DC ; PHI/DA ; PSI/DP	-.164	(.0136)	(.0644)	(.0794)	(.620)	(4.01)	(5.75)	[.945; .295]	[.0262; 2.37]	<-.794E-4>			
YD/DP ; PHI/DA ; THE/DB	-.0843	(-.0136)	(.0644)	(.0699)	(.0794)	(.445)	(2.59)	(4.01)	(5.75)	[.0404; .689]	<.517E-5>		
ZD/DB ; PHI/DA ; PSI/DP	.326	(.0163)	(.0644)	(.0699)	(.0794)	(-4.56)	(2.59)	(4.01)	(5.75)	[.00633; 1.86]	<-.000178>		
ZD/DC ; PHI/DA ; THE/DB ; PSI/DP	-.850	(.0177)	(-.0207)	(.0644)	(.0699)	(.0794)	(2.59)	(4.01)	(5.75)	<.662E-5>			
YD/DC ; PHI/DA ; THE/DB ; PSI/DP	-.00330	(.0222)	(.0644)	(.0699)	(.0794)	(2.59)	(-3.41)	(4.01)	(5.75)	<.532E-5>			

TABLE IV-5 CONTINUED
AH-IG TRANSFER FUNCTION FACTORS

CASE 59 HOVER SCAS OFF

DENOMINATOR: (0) (.440) (.821) [-.291; .359] [-.243; .542] [.837; .712] <.00694>
HD P PL

CONTROL NUMERATORS:

PHI/DA	.471	(0)	(.0735)	(.516)	[-.430; .283]	[.881; .482]	<.000331>
THE/DB	-.146	(0)	(.0155)	(1.13)	[.980; .471]	[-.212; .525]	<-.000157>
PSI/DP	-.813	(.720)			[-.0458; .402]	[-.460; .424]	[-.848; .720] <-.00883>
PHI/DB	-.0685	(0)	(.0721)	(-2.29)	[.988; .468]	[.103; .513]	<.000651>
PHI/DP	.192	(0)	(-.187)	(-3.19)	[-.194; .267]	[.817; .693]	<-.000392>
PHI/DC	-.0999	(0)	(.0260)	(.459)	[-.360; .614]	[.505; .710]	<-.000227>
THE/DA	.109	(0)	(-.0153)	(.358)	(.647)	[-.0525; .485]	<-.908E-4>
THE/DP	.0160	(0)	(.0126)	(2.78)	[-.0811; .475]	[.806; .658]	<.548E-4>
THE/DC	.0192	(0)	(.0443)	(.477)	[-.218; .549]	[.852; 1.74]	<.000370>
PSI/DA	.0319	(1.13)	(-1.55)	(-4.32)	[-.412; .287]	[.930; .492]	<.00481>
PSI/DB	-.00654	(.488)	(1.14)	(-1.37)	[.111; .498]	[-.942; 2.77]	<.00945>
PSI/DC	.579	(.245)			[-.500; .110]	[-.285; .558]	[.938; .830] <.000367>
XD/DB	1.24	(0)	(1.15)		[.977; .464]	[-.209; .520]	[.0469; 1.96] <.320>
YD/DA	.809	(.0588)	(.504)		[-.429; .283]	[.876; .477]	[.0172; 4.31] <.00813>
ZD/DC	-12.7	(0)	(.489)		[-.147; .268]	[-.250; .551]	[.918; .747] <-.0757>
XD/DC	-.0934	(0)	(.477)		[-.213; .547]	[.803; 1.37]	[-.473; 3.26] <-.267>
YD/DP	1.28	(-.196)	(.341)		[-.213; .274]	[.815; .697]	[.0185; 2.18] <-.0149>
ZD/DB	.198	(0)	(.416)	(1.47)	(-1.57)	[-.101; .522]	[.211; 1.57] <-.127>
PHI/DA ; THE/DB	-.0686	(0)	(-.00100)	(.0726)	[.987; .454]	<.103E-5>	
PHI/DA ; PSI/DP	-.388	(.0217)			[-.427; .281]	[-.904; .474]	<-.000149>
THE/DB ; PSI/DP	.119	(.0180)	(.331)	(1.13)	[-.132; .395]	<.000125>	
PHI/DB ; PSI/DP	.0569	(.0209)	(.429)	(-2.29)	[.0912; .503]	<-.000295>	
PHI/DP ; THE/DB	-.0270	(0)	(.0183)	(-.0260)	[.979; .539]	<.374E-5>	
PHI/DC ; THE/DB	.0159	(0)	(.0368)	(-.274)	[.957; .429]	<-.296E-4>	
THE/DA ; PSI/DP	-.0877	(-.00744)	(.507)		[-.101; .485]	<.776E-4>	
THE/DP ; PHI/DA	.00673	(0)	(-.00421)	(.191)	[.0124; .682]	<-.252E-5>	
THE/DC ; PHI/DA	.00945	(0)	(.431)	(3.01)	[.821; .0346]	<.147E-4>	
PSI/DA ; THE/DB	-.00464	(0)	(.422)	(1.14)	(-1.55)	(-4.36) <-.0150>	
PSI/DB ; PHI/DA	-.000893	(.00215)	(-1.01)	(1.38)	[-.895; 1.78]	<-.846E-6>	
PSI/DC ; THE/DB	-.0846	(.0436)	(.563)	(1.13)	[-.288; .467]	<-.000513>	
PSI/DC ; PHI/DA	.276	(.0273)			[-.421; .295]	[.926; .517] <.000175>	
XD/DB ; PHI/DA	.583	(0)	(.0728)		[.988; .447]	[.0469; 1.95] <.0321>	
XD/DB ; PSI/DP	-1.01	(.306)	(1.16)		[-.117; .391]	[.0471; 1.96] <-.210>	
YD/DA ; THE/DB	-.118	(0)	(.0586)		[.984; .444]	[.0173; 4.30] <-.0252>	
YD/DA ; PSI/DP	-.698				[-.426; .281]	[.902; .473]	[-.0128; 4.23] <-.222>
ZD/DC ; PHI/DA	-6.00	(0)	(.499)		[-.380; .116]	[.660; .236] <-.00224>	
ZD/DC ; THE/DB	1.86	(0)	(.0327)	(.472)	(1.11)	[-.235; .516] <.00851>	
ZD/DC ; PSI/DP	10.4				[-.0881; .282]	[-.251; .443]	[.912; .774] <.0971>
XD/DC ; PHI/DA	-.0452	(0)	(.0479)	(.427)	(2.01)	[-.293; 3.17] <-.0186>	
XD/DC ; THE/DB	-.0102	(0)	(.475)	(1.01)	(7.37)	[-.110; .552] <-.0110>	
XD/DC ; PSI/DP	.160				[-.134; .409]	[.919; 1.37]	[-.233; 2.64] <.348>
YD/DP ; PHI/DA	.448	(.125)	(-.263)		[-.437; .283]	[.903; .462]	<-.000252>
YD/DP ; THE/DB	-.186	(.0168)	(-.0490)		[1.00; .556]	[.00876; 2.12] <.000212>	
ZD/DB ; PHI/DA	.0918	(0)	(.0730)	(.528)	(-1.51)	[.348; 1.37] <-.0100>	
ZD/DB ; PSI/DP	-.161	(-1.57)	(1.58)		[-.0522; .465]	[.171; 1.46] <.183>	
PHI/DA ; THE/DB ; PSI/DP	.0566	(-.00102)	(.0209)	(.391)	<-.470E-6>		
PHI/DC ; THE/DB ; PSI/DP	.00265	(.0213)	(.0612)	(3.30)	<.114E-4>		
THE/DC ; PHI/DA ; PSI/DP	-.0117	(.00838)	(.0294)	(1.83)	<-.530E-5>		

TABLE IV-5 CONTINUED AH-IG TRANSFER FUNCTION FACTORS

CASE 59 HOVER SCAS OFF

CONTROL NUMERATORS CONCLUDED:

```

PSI/DC ; PHI/DA ; THE/DB  -.0402 (-.00111) (.0270) (.484) <.580E-6>
XD/DB ; PHI/DA ; PSI/DP  -.481 (-.0211) (.378) [-.0469; 1.95] <-.0145>
YD/DA ; THE/DB ; PSI/DP  .102 (-.00114) (.389) [-.0128; 4.23] <-.000808>
ZD/DC ; PHI/DA ; THE/DB   .873 (0) (.0221) (.0548) (.414) <.000438>
ZD/DC ; THE/DB ; PSI/DP  -1.52 (.0379) (1.12) [-.190; .417] <-.0112>
ZD/DC ; PHI/DA ; PSI/DP   4.97 (.00679) (.268) [-.0428; .129] <.000151>
XD/DC ; PHI/DA ; THE/DB  -.00512 (0) (.105) (.404) (6.85) <-.00148>
XD/DC ; PHI/DA ; PSI/DP   .0757 (.0252) (1.35) [-.275; 2.61] <.0174>
XD/DC ; THE/DB ; PSI/DP   .00749 (1.08) (8.33) [-.141; .306] <.00631>
YD/DP ; PHI/DA ; THE/DB  -.0653 (0) (.121) (-.269) (.368) <.000784>
ZD/DB ; PHI/DA ; PSI/DP  -.0759 (.0215) (-1.50) [.365; 1.36] <.00452>
ZD/DC ; PHI/DA ; THE/DB ; PSI/DP  -.722 (-.00845) (.0262) <-.000160>
XD/DC ; PHI/DA ; THE/DB ; PSI/DP   .00351 (.0194) (8.41) <.000571>

```

GUST NUMERATORS:

```

PHI/UG  -.00861 (0) (0) (.0376) (.106) [.979; .543] <-.101E-4>
THE/UG  -.000511 (0) (0) (.500) (.656) (5.22) [-.114; .497] <-.000216>
PSI/UG   .00110 (0) (0) (.0610) (.617) (-.911) (1.68) (2.42) <-.000154>
PHI/VG   .00901 (0) (0) (.419) [-.344; .365] [.841; .656] <.000216>
THE/VG  -.000904 (0) (0) (.0708) (-.833) [.813; .518] <.143E-4>
PSI/VG  -.0157 (0) (0) (.598) [-.367; .385] [.838; .790] <-.000866>
PHI/WG   .00569 (0) (0) (.0628) (.527) (-.702) [.323; .472] <-.295E-4>
THE/WG   .00342 (0) (0) (.0401) (.567) (1.35) [-.182; .523] <.288E-4>
PSI/WG   .00494 (0) (-.360) (.997) [.477; .437] [-.251; .983] <-.000326>
PHI/PG   .761 (0) (.0809) (.730) [-.301; .394] [.942; .505] <.00178>
THE/PG  -1.222 (0) (.0840) (.790) [.740; .352] [-.441; .502] <-.000461>
PSI/PG   .392 (.905) [-.303; .389] [.958; .654] [-.523; 1.10] <.0278>
PHI/QG   1.05 (0) (.0510) (.239) (-.318) (.493) [.675; .370] <-.000276>
THE/QG   .237 (0) (.0145) (.391) (.582) (1.90) [-.138; .515] <.000394>
PSI/QG   .122 (-.276) (.328) (1.11) [.720; .292] [-.884; 2.05] <-.00439>
PHI/RG   .0220 (0) (.328) (1.95) [-.412; .329] [.286; .488] <.000364>
THE/RG  -.0143 (0) (0) (.0585) (-.555) (1.03) [-.124; .498] <.000119>
PSI/RG   .540 (.741) [-.289; .349] [-.272; .565] [.893; .668] <.00694>
XD/UG   .0148 (0) (.517) (.627) (2.41) [-.104; .482] [-.154; 1.61] <.00694>
ZD/UG   .117 (0) (0) (.0472) (1.05) [.887; .374] [-.0948; .670] <.000364>
YD/VG   .0573 (0) (.421) [-.342; .365] [.836; .654] [.0636; 2.25] <.00694>
XD/WG   .0104 (0) (0) (.569) (-3.62) [-.180; .517] [.950; 2.01] <-.0232>
ZD/WG   .372 (0) (.519) [-.161; .391] [-.316; .553] [.904; .877] <.00694>
PHI/UG ; THE/DB   .00123 (0) (0) (.0720) [.989; .479] <.202E-4>
PHI/UG ; PSI/DP   .00679 (0) (0) (.0136) (.0796) (.574) <.422E-5>
THE/UG ; PHI/DA  -.000205 (0) (0) (.0736) (.617) (1.11) <-.103E-4>
THE/UG ; PSI/DP   .000398 (0) (.629) (5.27) [-.112; .457] <.000274>
PSI/UG ; PHI/DA   .000792 (-.00766) [.0890; .00136] [.785; .220] <-.544E-12>
PSI/UG ; THE/DB  -.000164 (0) (.572) (-.945) (1.15) (2.88) <.000294>
PHI/VG ; THE/DB  -.00138 (0) (0) (.0155) [.976; .479] <-.488E-5>
PHI/VG ; PSI/DP  -.00431 (0) [-.317; .412] [.860; .612] <-.000274>
THE/VG ; PHI/DA  -.000462 (0) (0) (-.0154) (.338) (1.17) <.282E-5>
THE/VG ; PSI/DP  -.000985 (0) (0) (-.0364) [.549; .564] <-.114E-4>
PSI/VG ; PHI/DA  -.00766 (0) [-.417; .290] [.917; .482] <-.000150>
PSI/VG ; THE/DB   .00229 (0) (0) (.399) (1.13) <.00103>

```

TABLE IV-5 CONTINUED
AH-IG TRANSFER FUNCTION FACTORS

CASE 59 HOVER SCAS OFF

GUST NUMERATORS CONTINUED:

PHI/WG ; THE/DB	-0.000598	(0)	(0)	(.0538)	(.145)	(.437)	<- .204E-5>	
PHI/WG ; PSI/DP	-0.00557	(0)	(.0281)	(-.622)	[.362; .443]	<.191E-4>		
THE/WG ; PHI/DA	.00159	(0)	(0)	(.0178)	(.0659)	(.532)	<.989E-6>	
THE/WG ; PSI/DP	-0.00286	(0)	(.0483)	(1.40)	[-.146; .420]	<- .341E-4>		
PSI/WG ; PHI/DA	.00214	(0)	(.0423)	(.455)	[-.363; .344]	<.490E-5>		
PSI/WG ; THE/DB	-0.000701	(0)	(.0620)	(1.14)	[-.370; .803]	<- .319E-4>		
PHI/PG ; THE/DB	-.127	(0)	(-.00147)	(.0808)	[.990; .444]	<.297E-5>		
PHI/PG ; PSI/DP	-.694	(.0197)	[-.309; .382]	[-.975; .591]	<- .000695>			
THE/PG ; PHI/DA	-.108	(0)	(0)	(.0810)	[.958; .452]	<- .00178>		
THE/PG ; PSI/DP	.174	(-.0391)	(-.377)	(.649)	[.188; .469]	<.000367>		
PSI/PG ; PHI/DA	.160	(.0368)	[-.547; .235]	[.839; .530]	<.911E-4>			
PSI/PG ; THE/DB	-0.0588	(0)	(.408)	(1.14)	[-.482; 1.10]	<- .0332>		
PHI/QG ; THE/DB	-.138	(0)	(.0143)	(.0763)	[.987; .451]	<- .307E-4>		
PHI/QG ; PSI/DP	-.881	(.0127)	(.251)	(-.314)	[.669; .342]	<.000104>		
THE/QG ; PHI/DA	.107	(0)	(.0103)	(.0685)	[.994; .448]	<.152E-4>		
THE/QG ; PSI/DP	-.194	(.0146)	(.436)	(1.93)	[-.140; .442]	<- .000467>		
PSI/QG ; PHI/DA	.0238	(-.0165)	(.170)	(.762)	[-.464; .591]	<- .177E-4>		
PSI/QG ; THE/DB	-0.0163	(.0143)	(.414)	(1.14)	[-.890; 2.00]	<- .000438>		
PHI/RG ; THE/DB	-0.00420	(0)	(.0153)	(.565)	[.450; .476]	<- .825E-5>		
PHI/RG ; PSI/DP	-.121	(.0580)	(.269)	(.635)	[-.370; .243]	<- .712E-4>		
THE/RG ; PHI/DA	-0.00681	(0)	(-.0157)	(.254)	[-.285; .419]	<.477E-5>		
THE/RG ; PSI/DP	-0.0302	(.0123)	(.671)	[-.0860; .469]	<- .548E-4>			
PSI/RG ; PHI/DA	.253	(.0167)	[-.428; .282]	[.906; .483]	<.785E-4>			
PSI/RG ; THE/DB	-0.0790	(.0153)	(.394)	(1.13)	[-.241; .539]	<- .000157>		
XD/UG ; PHI/DA	.00685	(0)	(.0736)	[.999; .696]	[-.172; 1.16]	<.000331>		
XD/UG ; THE/DB	-0.00153	(0)	(.307)	(.401)	(1.31)	[-.390; .798]	<- .000157>	
XD/UG ; PSI/DP	-0.0119	(.619)	(2.41)	[-.109; .445]	[-.152; 1.58]	<- .00883>		
ZD/UG ; PHI/DA	.0547	(0)	(0)	(.195)	(.532)	[.994; .0553]	<.174E-4>	
ZD/UG ; THE/DB	-0.0170	(0)	(0)	(.461)	(1.24)	[-.167; .640]	<- .00397>	
ZD/UG ; PSI/DP	-0.0947	(0)	(.0467)	(.292)	(.986)	[-.149; .603]	<- .000463>	
YD/VG ; PHI/DA	.0197	(0)	(.253)	[-.436; .280]	[.911; .448]	<.785E-4>		
YD/VG ; THE/DB	-0.00848	(0)	(.0155)	[.978; .485]	[.0894; 2.25]	<- .000157>		
YD/VG ; PSI/DP	-0.0264	[-.321; .414]	[.856; .607]	[.0963; 2.30]	<- .00883>			
XD/WG ; PHI/DA	.00496	(0)	(0)	(.0691)	(.533)	(-3.09)	(3.32)	<- .00187>
XD/WG ; THE/DB	-0.00576	(0)	(0)	(.553)	(1.08)	[-.187; .482]	<- .000803>	
XD/WG ; PSI/DP	-0.00772	(0)	(-3.92)	[-.132; .411]	[.938; 2.11]	<.0227>		
ZD/WG ; PHI/DA	.175	(0)	(.0741)	(.461)	(.532)	[-.346; .323]	<.000331>	
ZD/WG ; THE/DB	-0.0551	(0)	(.0160)	(.609)	(1.10)	[-.230; .515]	<- .000157>	
ZD/WG ; PSI/DP	-0.302	[.0352; .399]	[-.481; .479]	[.875; .894]	<- .00883>			
XD/UG ; ZD/DC	-.178	(0)	(.473)	(2.62)	[-.00342; .392]	[-.129; 1.50]	<- .0757>	
YD/VG ; ZD/DC	-.649	(0)	[-.211; .289]	[.954; .517]	[.0675; 2.29]	<- .0757>		
PHI/UG ; THE/DB ; PSI/DP	-0.000966	(0)	(.0209)	(.454)	<- .916E-5>			
THE/UG ; PHI/DA ; PSI/DP	.000158	(0)	(.0217)	(1.35)	<.464E-5>			
PSI/UG ; PHI/DA ; THE/DB	-0.000116	(0)	(.00215)	(.106)	<- .263E-7>			
PHI/VG ; THE/DB ; PSI/DP	.000700	(0)	(.0180)	(.309)	<.390E-5>			
THE/VG ; PHI/DA ; PSI/DP	.000491	(0)	(-.00744)	(.660)	<- .241E-5>			
PSI/VG ; PHI/DA ; THE/DB	.00112	(0)	(0)	(.418)	<.000467>			
PHI/WG ; THE/DB ; PSI/DP	.000616	(0)	(.0213)	(.0662)	<.867E-6>			
THE/WG ; PHI/DA ; PSI/DP	-.00134	(0)	(.00983)	(.0310)	<- .409E-6>			
PSI/WG ; PHI/DA ; THE/DB	-0.000309	(0)	(-.00128)	(.0448)	<.177E-7>			

TABLE IV-5 CONTINUED
AH-IG TRANSFER FUNCTION FACTORS

CASE 59 HOVER SCAS OFF

GUST NUMERATORS CONCLUDED:

PHI/PG ; THE/DB ; PSI/DP	.114 (-.00259) (.0208) (.391) <-.240E-5>
THE/PG ; PHI/DA ; PSI/DP	.0867 (0) (.0182) (.389) <.000614>
PSI/PG ; PHI/DA ; THE/DB	-.0236 (0) (.0311) (.392) <-.000288>
PHI/QG ; THE/DB ; PSI/DP	.115 (.0148) (.0214) (.387) <.141E-4>
THE/QG ; PHI/DA ; PSI/DP	-.0887 (.380) [.973; .0144] <-.699E-5>
PSI/QG ; PHI/DA ; THE/DB	-.00327 (0) (-.0720) (.340) <.800E-4>
PHI/RG ; THE/DB ; PSI/DP	.0180 (.0151) (.0230) (.454) <.284E-5>
THE/RG ; PHI/DA ; PSI/DP	.00200 (-.972) [.439; .0282] <-.155E-5>
PSI/RG ; PHI/DA ; THE/DB	-.0369 (-.00107) (.0160) (.407) <.256E-6>
XD/UG ; PHI/DA ; THE/DB	-.000744 (0) (-.0399) (.0690) (.502) <.103E-5>
XD/UG ; PHI/DA ; PSI/DP	-.00554 (.0217) (.918) [-.176; 1.16] <-.000149>
XD/UG ; THE/DB ; PSI/DP	.00124 (.142) (1.31) [-.362; .736] <.000125>
ZD/UG ; PHI/DA ; THE/DB	-.00793 (0) (0) (.0730) (.537) <-.000311>
ZD/UG ; PHI/DA ; PSI/DP	-.0451 (0) (.0231) (.0404) (.186) <-.784E-5>
ZD/UG ; THE/DB ; PSI/DP	.0138 (0) (1.24) [-.220; .577] <.00570>
YD/VG ; PHI/DA ; THE/DB	-.00286 (0) (-.00105) (.221) (.385) <.256E-6>
YD/VG ; PHI/DA ; PSI/DP	-.00893 [-.449; .280] [.891; .462] <-.000149>
YD/VG ; THE/DB ; PSI/DP	.00399 (.0181) (.308) [.135; 2.38] <.000125>
XD/WG ; PHI/DA ; THE/DB	-.00269 (0) (0) (.0764) (.496) <-.000102>
XD/WG ; PHI/DA ; PSI/DP	-.00379 (0) (.0254) (-3.21) (3.54) <.00110>
XD/WG ; THE/DB ; PSI/DP	.00468 (0) (1.06) [-.120; .313] <.000487>
ZD/WG ; PHI/DA ; THE/DB	-.0258 (0) (-.00103) (.0724) (.532) <.103E-5>
ZD/WG ; PHI/DA ; PSI/DP	-.145 (.0216) (.461) [-.344; .322] <-.000149>
ZD/WG ; THE/DB ; PSI/DP	.0448 (.0193) (1.09) [-.168; .365] <.000125>
XD/UG ; ZD/DC ; PHI/DA	-.0820 (0) [-.0257; .197] [.372; .838] <-.00224>
XD/UG ; ZD/DC ; THE/DB	.0206 (0) (.471) (1.35) [-.294; .806] <.00851>
XD/UG ; ZD/DC ; PSI/DP	.133 (2.62) [.0410; .372] [-.137; 1.42] <.0971>
YD/VG ; ZD/DC ; PHI/DA	-.221 (0) (-.105) (.437) [.251; .249] <.000629>
YD/VG ; ZD/DC ; THE/DB	.0960 (0) (.0327) (.520) [.0939; 2.28] <.00851>
YD/VG ; ZD/DC ; PSI/DP	.347 (.574) [-.182; .298] [.0880; 2.34] <.0971>
XD/UG ; PHI/DA ; THE/DB ; PSI/DP	.000612 (.0190) (-.0403) <-.470E-6>
ZD/UG ; PHI/DA ; THE/DB ; PSI/DP	.00655 (0) (.0215) <.000140>
YD/VG ; PHI/DA ; THE/DB ; PSI/DP	.00130 (-.00101) (.358) <-.470E-6>
XD/WG ; PHI/DA ; THE/DB ; PSI/DP	.00221 (0) (.0196) <.433E-4>
ZD/WG ; PHI/DA ; THE/DB ; PSI/DP	.0213 (-.00105) (.0211) <-.470E-6>
XD/UG ; ZD/DC ; PHI/DA ; THE/DB	.0101 (0) (.131) (.331) <.000438>
YD/VG ; ZD/DC ; PHI/DA ; THE/DB	.0321 (0) (.00432) (.227) <.315E-4>
YD/VG ; ZD/DC ; PHI/DA ; PSI/DP	.116 (.212) [.117; .0785] <.000151>
XD/WG ; ZD/DC ; PHI/DA ; THE/DB	.0361 (0) (.119) (.345) <.00148>
XD/UG ; ZD/DC ; PHI/DA ; THE/DB ; PSI/DP	-.00821 (.0195) <-.000160>
YD/VG ; ZD/DC ; PHI/DA ; THE/DB ; PSI/DP	-.0168 (.00951) <-.000160>
XD/WG ; ZD/DC ; PHI/DA ; THE/DB ; PSI/DP	-.0295 (.0193) <-.000571>

TABLE IV-5 CONTINUED
AH-IG TRANSFER FUNCTION FACTORS

CASE 59 HOVER SCAS ON

DENOMINATOR: (0) (.0781) (.207) (.247) (.389) (.802) (2.39) [-.126; .195] [-.508; .218] [.647; 2.32] [.717; 3.35] <.000329>
HD P PL

CONTROL NUMERATORS:

PHI/DA .471 (0) (.0644) (.262) (.390) (.803) (2.52) (5.75) [.838; .0555] [-.168; .124] [.642; 2.30] <.905E-5>
 THE/DB -.146 (0) (-.0162) (.0699) (.0925) (.136) (.390) (2.59) [-.272; .204] [.647; 2.33] [.733; 3.23] <-.502E-5>
 PSI/DP -.813 (.0794) (.207) (.247) (.389) (.802) (2.40) (4.01) [-.146; .192] [-.535; .210] [.734; 3.42] <-.000188>

PHI/DB -.0685 (0) (.0699) (.369) (.430) (.998) (-2.28) (2.59) [.842; .0541] [.0964; .505] [.641; 2.31] <.178E-4>
 PHI/DP .192 (0) (-.0457) (.0794) (.207) (.235) (.391) (.790) (1.97) (4.01) [-.101; .183] [.814; 1.38] <-.640E-5>
 PHI/DC -.0999 (0) (.0268) (.0799) (.368) (-.512) (-.711) (2.22) [.893; .285] [-.994; .974] [.814; 1.52] <-.112E-4>

THE/DA .112 (0) (-.00835) (.0644) (.0747) (.417) (.436) (.507) (5.75) [-.103; .513] [.636; 2.21] <-.307E-5>
 THE/DP .0160 (0) (.00778) (.0794) (.207) (-.304) (.393) (-.646) (-1.66) (4.01) [-.537; .152] [.861; 3.71] <.333E-6>
 THE/DC .0192 (0) (.0442) (.0775) (.167) (.419) (.433) (3.01) [-.296; .224] [.843; 1.75] [.682; 4.37] <.176E-4>

PSI/DA .0319 (.0644) (.258) (.422) (.536) (.623) (.718) (1.21) (-1.53) (2.54) (-4.36) (5.75) [-.148; .127] <.000103>
 PSI/DB -.00654 (.0699) (.291) (1.66) (2.59) (-4.69) (.399) (.401) [.969; .438] [-.754; 1.04] [.320; 1.50] <.000202>
 PSI/DC .579 (.132) (.261) (.479) (.823) (2.39) [-.655; .0417] [-.317; .257] [.996; .559] [.732; 3.41] <.784E-5>

XD/DA 1.24 (0) (.0699) (.0958) (.136) (.377) (2.59) [-.245; .200] [.0466; 1.95] [.647; 2.33] [.734; 3.24] <.00961>
 XD/DB .809 (.0644) (.262) (.388) (.803) (2.52) (5.75) [.829; .0428] [-.167; .125] [.631; 2.34] [.0239; 4.25] <.000173>
 XD/DC -12.7 (0) (.0769) (.795) (2.39) [-.163; .129] [.997; .209] [-.394; .209] [.633; 2.30] [.717; 3.36] <-.00355>

XD/DC -.0934 (0) (.0777) (.176) (.320) (.605) (2.82) [-.240; .218] [.795; 1.97] [-.638; 2.41] [.601; 4.17] <-.0129>
 YD/DP 1.28 (-.0677) (.0794) (.207) (.282) (.379) (.796) (2.25) (4.01) [-.0963; .186] [.248; .883] [-.555; 3.27] <-.000318>
 ZD/DB -.198 (0) (.0631) (.0699) (.201) (-1.53) (2.59) [-.191; .258] [.369; 1.44] [.686; 2.30] [-.694; 3.19] <-.00516>

PHI/DA ; THE/DB -.0686 (0) (-.00100) (.0644) (.0699) (.390) (2.59) (5.75) [.840; .0544] [.643; 2.30] <.282E-7>
 PHI/DA ; PSI/DP -.368 (.0217) (.0644) (.0794) (.262) (.390) (.803) (2.52) (4.01) (5.75) [-.164; .125] <-.319E-5>
 THE/DB ; PSI/DP .119 (.0180) (.0699) (.0794) (.146) (.390) (2.59) (4.01) [-.276; .187] [.748; 3.31] <.268E-5>

PHI/DB ; PSI/DP .0569 (.0209) (.0699) (.0794) (.370) (.429) (1.00) (-2.29) (2.59) (4.01) [-.0912; .503] <-.629E-5>
 PHI/DP ; THE/DB -.0270 (0) (-.0183) (-.0249) (.0699) (.0794) (.197) (.393) (2.59) (4.01) [.823; 1.20] <.798E-7>
 PHI/DC ; THE/DB .0159 (0) (.0371) (.0699) (.368) (.959) (-1.12) (2.59) [-.679; .0852] [.823; 1.60] <-.784E-6>

THE/DA ; PSI/DP -.0877 (-.00744) (.0644) (.0794) (.417) (.435) (.507) (4.01) (5.75) [-.101; .485] <.166E-5>
 THE/DP ; PHI/DA .00673 (0) (-.00561) (.0644) (-.0709) (.0794) (.214) (.393) (.642) (-2.98) (4.01) (5.75) <-.506E-7>
 THE/DC ; PHI/DA .00945 (0) (.0644) (.0688) (.419) (.433) (4.99) (5.75) [-.844; .0238] [-.850; 1.75] <.380E-6>

PSI/DA ; THE/DB -.00560 (0) (.0644) (.0699) (.422) (.541) (.588) (1.14) (-1.55) (2.59) (-4.36) (5.75) <-.000387>
 PSI/DB ; PHI/DA -.000893 (.00215) (.0644) (.0699) (.102) (-.738) (2.02) (2.59) (-4.85) (5.75) [.965; .436] <-.180E-7>
 PSI/DC ; THE/DB -.0846 (.0437) (.0699) (.177) (.486) (.541) (.588) (2.59) [-.345; .234] [.749; 3.30] <-.109E-4>

PSI/DC ; PHI/DA .276 (.0273) (.0644) (.256) (.478) (.824) (2.52) (5.75) [-.146; .130] [.996; .559] <.373E-5>
 XD/DB ; PHI/DA .583 (0) (.0644) (.0699) (.378) (2.59) (5.75) [.840; .0545] [.0469; 1.95] [.643; 2.30] <.000890>
 XD/DB ; PSI/DP -1.01 (.0699) (.0794) (.148) (.378) (2.59) (4.01) [-.241; .182] [.0486; 1.95] [.749; 3.31] <-.00447>

YD/DA ; THE/DB -.118 (0) (.0644) (.0699) (.389) (2.59) (5.75) [.832; .0421] [.632; 2.34] [.0234; 4.25] <-.000535>
 YD/DA ; PSI/DP -.698 (.0644) (.0794) (.262) (.388) (.803) (2.52) (4.01) (5.75) [-.163; .125] [-.0125; 4.23] <-.00473>
 ZD/DC ; PHI/DA -6.00 (0) (.0644) (.227) (.796) (2.53) (5.75) [-.656; .0195] [.718; .0857] [.629; 2.28] <-.146E-4>

ZD/DC ; THE/DB 1.86 (0) (.0333) (.0699) (.0730) (.158) (2.59) [-.292; .213] [.632; 2.31] [.734; 3.24] <.000331>
 ZD/DC ; PSI/DP 10.4 (.0794) (.795) (2.39) (4.01) [-.196; .124] [-.401; .203] [.996; .210] [.734; 3.42] <.00207>
 XD/DC ; PHI/DA -.0452 (0) (.0644) (.321) (.606) (4.54) (5.75) [.990; .0485] [.805; 2.01] [-.619; 2.30] <-.000742>

XD/DC ; THE/DB -.0102 (0) (.0699) (.0890) (.136) (2.59) (7.46) [-.258; .183] [.614; 2.38] [.745; 3.17] <-.000319>
 XD/DC ; PSI/DP .160 (.0794) (.177) (.319) (.605) (1.97) (4.01) [-.219; .209] [-.688; 2.07] [.753; 3.40] <.00742>
 YD/DP ; PHI/DA .448 (.0644) (.0794) (.128) (.269) (-.271) (.356) (.800) (2.53) (4.01) (5.75) [-.176; .123] <-.538E-5>

YD/DP ; THE/DB -.186 (.0169) (-.0468) (.0699) (.0794) (.193) (.383) (2.59) (4.01) [-.271; .861] [.557; 3.12] <.452E-5>
 ZD/DB ; PHI/DA .0918 (0) (.0644) (.0699) (-1.50) (2.59) (5.75) [.841; .0549] [.375; 1.38] [.634; 2.28] <-.000274>
 ZD/DB ; PSI/DP -.161 (.0699) (.0794) (.200) (-1.53) (2.59) (4.01) [-.206; .254] [.369; 1.44] [.753; 3.21] <.00391>

PHI/DA ; THE/DB ; PSI/DP .0566 (-.00102) (-.0209) (.0644) (.0699) (.0794) (.391) (2.59) (4.01) (5.75) <-.100E-7>
 PHI/DC ; THE/DB ; PSI/DP .00265 (.0213) (.0612) (.0699) (.0794) (.370) (1.00) (2.59) (3.30) (4.01) <.244E-6>
 THE/DC ; PHI/DA ; PSI/DP -.0117 (.00838) (.0294) (.0644) (.0794) (.417) (.435) (1.81) (4.01) (5.75) <-.113E-6>

TABLE IV-5 CONTINUED
AH-IG TRANSFER FUNCTION FACTORS

CASE 59 HOVER SCAS ON

CONTROL NUMERATORS CONCLUDED:

PSI/DC ; PHI/DA ; THE/DB	-0.0402	(-.00111)	(.0270)	(.0644)	(.0699)	(.484)	(.541)	(.588)	(2.59)	(5.75)	<-.124E-7>	
XD/DB ; PHI/DA ; PSI/DP	-.481	(.0211)	(.0644)	(.0699)	(.0794)	(.378)	(2.59)	(4.01)	(5.75)	[.0469; 1.95]	<-.000310>	
YD/DA ; THE/DB ; PSI/DP	.102	(-.00114)	(.0644)	(.0699)	(.0794)	(.384)	(2.59)	(4.01)	(5.75)	[-.0128; 4.23]	<-.172E-4>	
ZD/DC ; PHI/DA ; THE/DB	.873	(0)	(.0209)	(.0644)	(.0699)	(2.59)	(5.75)	[.900; .0425]	[.629; 2.28]	<.115E-4>		
ZD/DC ; THE/DB ; PSI/DP	-1.52	(.0379)	(.0699)	(.0794)	(.160)	(2.59)	(4.01)	[-.303; .203]	[.748; 3.31]	<-.000239>		
ZD/DC ; PHI/DA ; PSI/DP	4.97	(.00667)	(.0644)	(.0794)	(.227)	(.796)	(2.52)	(4.01)	(5.75)	[.332; .0426]	<.322E-5>	
XD/DC ; PHI/DA ; THE/DB	-0.0512	(0)	(.0644)	(.0699)	(2.59)	(5.75)	(6.66)	[.767; .0561]	[.610; 2.34]	<-.393E-4>		
XD/DC ; PHI/DA ; PSI/DP	.0758	(.0251)	(.0644)	(.0794)	(.320)	(.606)	(2.01)	(4.01)	(5.75)	[-.718; 2.06]	<.000372>	
XD/DC ; THE/DB ; PSI/DP	.00749	(.0699)	(.0794)	(.143)	(2.59)	(4.01)	(3.30)	[-.288; .155]	[.747; 3.31]	<.000135>		
YD/DP ; PHI/DA ; THE/DB	-.0537	(0)	(.0644)	(.0699)	(.0794)	(.121)	(-.269)	(.368)	(2.59)	(4.01)	(5.75)	<.137E-4>
ZD/DB ; PHI/DA ; PSI/DP	-.0759	(.0215)	(.0644)	(.0699)	(.0794)	(-1.50)	(2.59)	(4.01)	(5.75)	[.365; 1.36]	<.964E-4>	
ZD/DC ; PHI/DA ; THE/DB ; PSI/DP	-.722	(.00845)	(.0262)	(.0644)	(.0699)	(.0794)	(2.59)	(4.01)	(5.75)	<-.341E-5>		
XD/DC ; PHI/DA ; THE/DB ; PSI/DP	.00351	(.0194)	(.0644)	(.0699)	(.0794)	(2.59)	(4.01)	(5.75)	(8.41)	<.122E-4>		

GUST NUMERATORS:

PHI/UG	-.00861	(0)	(0)	(.217)	(.369)	(.455)	(.784)	(.997)	(2.44)	[.845; .0538]	[.639; 2.27]	<-.890E-5>	
THE/UG	-.000511	(0)	(0)	(.0775)	(.212)	(.421)	(.431)	(6.25)	[-.153; .303]	[.984; 1.59]	[.599; 2.15]	<-.102E-4>	
PSI/UG	.00110	(0)	(0)	(.217)	(.286)	(.525)	(.639)	(-.655)	(.769)	(2.36)	[.666; .411]	[.972; 4.68]	<-.000101>
PHI/VG	-.00901	(0)	(0)	(.0779)	(.366)	(.789)	(.984)	(2.67)	[-.151; .209]	[.987; .329]	[.629; 2.02]	<.102E-4>	
THE/VG	-.000904	(0)	(0)	(-.0256)	(.0268)	(.0774)	(.417)	(.436)	(.667)	[.825; 2.22]	[.456; 3.99]	<.457E-6>	
PSI/VG	-.0157	(0)	(0)	(.0696)	(.257)	(.418)	(.546)	(.582)	(.798)	(2.38)	[-.230; .146]	[.745; 3.50]	<-.185E-4>
PHI/WG	.00569	(0)	(0)	(-.243)	(.369)	(.986)	[.907; .0563]	[.891; .273]	[.937; 1.16]	[.623; 2.44]	<-.948E-6>		
THE/WG	.00342	(0)	(0)	(.0444)	(.0851)	(.167)	(.421)	(.432)	[-.276; .233]	[.660; 2.38]	[.763; 3.26]	<.128E-5>	
PSI/WG	.00494	(0)	(-.146)	(.270)	(.519)	(2.27)	[.875; .200]	[-.180; .391]	[.992; .687]	[.651; 3.26]	<-.696E-5>		
PHI/PG	.761	(0)	(.281)	(.370)	(.390)	(.757)	(1.00)	(3.27)	[-.800; .0556]	[-.132; .187]	[.649; 2.35]	<.460E-4>	
THE/PG	-.222	(0)	(.0671)	(-.0704)	(-.116)	(.387)	(.414)	(.437)	[-.585; .184]	[.632; 2.29]	[.636; 3.11]	<-.147E-4>	
PSI/PG	.392	(.391)	(.882)	(2.58)	[-.109; .196]	[.997; .277]	[-.194; .491]	[.998; .547]	[.655; 2.82]	<.000593>			
PHI/QG	1.05	(0)	(-.100)	(.110)	(.219)	(.371)	(.386)	(.879)	(1.00)	(1.96)	[.968; .0457]	[.643; 2.31]	<-.704E-5>
THE/QG	.237	(0)	(.0145)	(.0784)	(.212)	(.360)	(.418)	(.434)	[-.245; .271]	[.639; 2.32]	[.836; 3.36]	<.175E-4>	
PSI/QG	.122	(-.0897)	(.102)	(.220)	(.503)	(2.14)	[.998; .347]	[.953; .628]	[.719; 1.48]	[-.615; 1.85]	<-.936E-4>		
PHI/RG	.0220	(0)	(.228)	(.367)	(.453)	(.765)	(1.03)	(9.82)	[-.512; .0921]	[.660; .136]	[.871; 2.76]	<.768E-5>	
THE/RG	-.0143	(0)	(.0136)	(.0654)	(.220)	(.415)	(.438)	(-2.72)	[-.134; .305]	[.681; 1.11]	[.751; 3.36]	<.178E-5>	
PSI/RG	.540	(.213)	(.251)	(.407)	(.550)	(.574)	(.808)	(2.40)	[-.00397; .175]	[-.370; .244]	[.723; 3.36]	<.000148>	
XD/UG	.0148	(0)	(.0773)	(.212)	(.325)	(.667)	(3.29)	[-.0960; .302]	[.172; .776]	[.596; 2.39]	[.871; 2.47]	<.000329>	
ZD/UG	.117	(0)	(0)	(.00608)	(.0635)	(.203)	(.220)	(.797)	(2.40)	[-.218; .273]	[.657; 2.33]	[.715; 3.33]	<.172E-4>
YD/VG	.0573	(0)	(.0779)	(.309)	(.347)	(.806)	(2.52)	[-.174; .213]	[.811; .449]	[.524; 1.89]	[.526; 3.22]	<.000329>	
XD/WG	.0104	(0)	(0)	(.0820)	(.176)	(.319)	(.594)	(-1.06)	(8.62)	[-.210; .226]	[.647; 2.36]	[.759; 3.51]	<-.000906>
ZD/WG	.372	(0)	(.0789)	(.212)	(.225)	(.782)	(2.44)	[-.206; .196]	[-.510; .229]	[.651; 2.33]	[.718; 3.36]	<.000329>	
PHI/UG ; THE/DB	.00123	(0)	(0)	(.0699)	(.369)	(.454)	(.997)	(2.59)	[.843; .0541]	[.641; 2.26]	<.554E-6>		
PHI/UG ; PSI/DP	.00679	(0)	(0)	(.0206)	(.0794)	(.217)	(.370)	(.454)	(.784)	(1.00)	[2.46; 4.01]	<.313E-5>	
THE/UG ; PHI/DA	-.000205	(0)	(0)	(.0644)	(.421)	(.431)	(1.30)	(5.75)	[.836; .0555]	[.574; 2.26]	<-.281E-6>		
THE/UG ; PSI/DP	.000398	(0)	(.0794)	(.212)	(.417)	(.435)	(4.01)	(6.30)	[-.163; .285]	[.963; 1.54]	<.586E-5>		
PSI/UG ; PHI/DA	.000792	(0)	(0)	(.0644)	(.114)	(.228)	(.525)	(.639)	(.768)	(2.53)	(5.75)	<.498E-5>	
PSI/UG ; THE/DB	-.000164	(0)	(.0699)	(.282)	(.541)	(.588)	(-.667)	(2.59)	[.656; .421]	[.986; 4.46]	<.627E-5>		
PHI/VG ; THE/DB	-.00138	(0)	(0)	(.0162)	(.0699)	(.0874)	(.322)	(.365)	(.981)	(2.59)	[.654; 1.95]	<-.156E-6>	
PHI/VG ; PSI/DP	-.00431	(0)	(.0794)	(.370)	(.789)	(1.00)	(3.04)	(4.01)	[-.160; .214]	[.985; .324]	<-.586E-5>		
THE/VG ; PHI/DA	-.000462	(0)	(0)	(-.00836)	(.0644)	(.0751)	(.417)	(.436)	(.660)	(5.75)	[-.816; 2.72]	<.954E-7>	
THE/VG ; PSI/DP	.000985	(0)	(0)	(-.0213)	(.0288)	(.0794)	(.417)	(.435)	(.667)	(4.01)	[-.628; 3.24]	<-.243E-6>	
PSI/VG ; PHI/DA	-.00766	(0)	(.0644)	(.259)	(.418)	(.546)	(.583)	(.794)	(2.52)	(5.75)	[-.148; .127]	<-.319E-5>	
PSI/VG ; THE/DB	.00229	(0)	(0)	(.0341)	(.0699)	(.418)	(.541)	(.588)	(2.59)	[.765; 3.38]	<.215E-4>		

TABLE IV-5 CONTINUED
AH-IG TRANSFER FUNCTION FACTORS

CASE 59 HOVER SCAS ON

GUST NUMERATORS CONTINUED:

PHI/WG ; THE/DB	-0.00599	(0)	(0)	(.0585)	(.0699)	(.369)	(1.01)	(2.59)	[.794; .0611]	[.647; 2.50]	<-.550E-7>			
PHI/WG ; PSI/DP	-0.00557	(0)	(.0280)	(.0794)	(-.229)	(.370)	(1.00)	(4.01)	[.895; .270]	[.942; 1.15]	<.408E-6>			
THE/WG ; PHI/DA	.00159	(0)	(0)	(.0156)	(.0644)	(.420)	(.432)	(5.75)	[.895; .0540]	[.656; 2.34]	<.264E-7>			
THE/WG ; PSI/DP	-0.00286	(0)	(.0485)	(.0794)	(.169)	(.417)	(.435)	(4.01)	[-.283; .219]	[.781; 3.35]	<-.727E-6>			
PSI/WG ; PHI/DA	.00214	(0)	(.0425)	(.0644)	(.249)	(.519)	(2.50)	(5.75)	[-.0606; .142]	[.992; .687]	<.104E-6>			
PSI/WG ; THE/DB	-0.000701	(0)	(.0621)	(.0699)	(.215)	(.541)	(.588)	(2.59)	[-.253; .362]	[.701; 1.10]	<-.680E-6>			
PHI/PG ; THE/DB	-.127	(0)	(-.00174)	(.0699)	(.370)	(.391)	(1.00)	(2.59)	[.816; .0541]	[.643; 2.37]	<.954E-7>			
PHI/PG ; PSI/DP	-.694	(0)	(.0197)	(.0794)	(.281)	(.370)	(.390)	(.756)	(1.00)	(3.17)	(4.01)	[-.131; .187]	<-.148E-4>	
THE/PG ; PHI/DA	-.108	(0)	(0)	(.0644)	(.389)	(.414)	(.437)	(5.75)	[.767; .0560]	[.628; 2.25]	<-.446E-4>			
THE/PG ; PSI/DP	.174	(-.0398)	(.0794)	(-.151)	(.388)	(.417)	(.435)	(4.01)	[.592; .180]	[.647; 3.21]	<.784E-5>			
PSI/PG ; PHI/DA	.160	(.0365)	(.0644)	(.271)	(.390)	(.684)	(2.55)	(5.75)	[-.279; .112]	[.997; .546]	<.194E-5>			
PSI/PG ; THE/DB	-0.0588	(0)	(.0699)	(.264)	(.393)	(.541)	(.533)	(2.59)	[-.159; .503]	[.637; 2.82]	<-.000708>			
PHI/QG ; THE/DB	-.138	(0)	(.0144)	(.0699)	(.371)	(.387)	(1.00)	(2.59)	[.933; .0554]	[.643; 2.31]	<-.844E-6>			
PHI/QG ; PSI/DP	-.881	(0)	(.0128)	(.0734)	(-.0991)	(.115)	(.219)	(.370)	(.387)	(.882)	(1.00)	(1.96)	(4.01)	<.221E-5>
THE/QG ; PHI/DA	-.107	(0)	(.0109)	(.0644)	(.380)	(.418)	(.434)	(5.75)	[.850; .0515]	[.645; 2.30]	<.417E-6>			
THE/QG ; PSI/DP	-.194	(.0146)	(.0794)	(.212)	(.381)	(.417)	(.435)	(4.01)	[-.251; .255]	[.837; 3.40]	<-.997E-5>			
PSI/QG ; PHI/DA	.0238	(-.0167)	(.0644)	(.196)	(.353)	(.500)	(2.39)	(5.75)	[-.0564; .284]	[.934; .620]	<-.379E-6>			
PSI/QG ; THE/DB	-0.163	(.0143)	(.0699)	(.541)	(.588)	(2.59)	[.995; .354]	[.739; 1.30]	[.589; .354]	[.739; 1.30]	<-.934E-5>			
PHI/RG ; THE/DB	-0.00420	(0)	(.0153)	(.0699)	(.367)	(.453)	(1.04)	(2.59)	[.575; .0699]	[.843; 4.67]	<-.214E-6>			
PHI/RG ; PSI/DP	-.121	(.0525)	(.0794)	(.230)	(.370)	(.454)	(.763)	(1.00)	(2.67)	(4.01)	[-.121; .0975]	<-.152E-5>		
THE/RG ; PHI/DA	-0.00681	(0)	(.0644)	(.120)	(.415)	(.438)	(-1.88)	(5.75)	[-.496; .0282]	[.639; 1.21]	<.121E-6>			
THE/RG ; PSI/DP	.00299	(.0123)	(.0794)	(.221)	(.417)	(.435)	(4.01)	(-6.40)	[-.0178; .324]	[.467; 1.93]	<-.117E-5>			
PSI/RG ; PHI/DA	.253	(.0167)	(.0644)	(.260)	(.407)	(.550)	(.574)	(.809)	(2.53)	(5.75)	[-.163; .125]	<.167E-5>		
PSI/RG ; THE/DB	-0.0790	(.0153)	(.0699)	(.180)	(.407)	(.541)	(.588)	(2.59)	[-.278; .249]	[.736; 3.26]	<-.335E-5>			
XD/UG ; PHI/DA	-0.00685	(0)	(.0644)	(.326)	(.664)	(1.96)	(5.75)	[.837; .0555]	[.117; .708]	[.630; 2.34]	<.905E-5>			
XD/UG ; THE/DB	-0.00153	(0)	(.0699)	(.138)	(2.59)	[.946; .127]	[-.368; .375]	[.646; 2.32]	[.738; 3.27]	<-.502E-5>				
XD/UG ; PSI/DP	-0.0119	(.0794)	(.212)	(.325)	(.667)	(3.35)	(4.01)	[-.108; .283]	[.188; .786]	[.833; 2.57]	<-.000188>			
ZD/UG ; PHI/DA	.0547	(0)	(0)	(.00328)	(.0644)	(.224)	(.797)	(2.51)	(5.75)	[.843; .0548]	[.647; 2.31]	<.475E-6>		
ZD/UG ; THE/DB	-0.0170	(0)	(0)	(.0631)	(.0699)	(.199)	(2.59)	[-.216; .271]	[.658; 2.34]	[.728; 3.22]	<-.000161>			
ZD/UG ; PSI/DP	-0.0947	(0)	(.00464)	(.0794)	(.202)	(.220)	(.797)	(2.40)	(4.01)	[-.237; .269]	[.737; 3.39]	<-.988E-5>		
YD/VG ; PHI/DA	-0.0197	(0)	(.0567)	(.0644)	(.270)	(.353)	(.804)	(2.52)	(5.75)	[-.183; .125]	[.597; 1.72]	<.366E-5>		
YD/VG ; THE/DB	-0.00848	(0)	(.0162)	(.0699)	(.0865)	(.357)	(2.59)	[.788; .424]	[.559; 1.91]	[.518; 3.16]	<-.502E-5>			
YD/VG ; PSI/DP	-0.0264	(.0794)	(.312)	(.343)	(.807)	(2.73)	(4.01)	[-.192; .218]	[.805; .433]	[.472; 3.27]	<-.000188>			
XD/WG ; PHI/DA	-0.0497	(0)	(0)	(.0644)	(.319)	(.595)	(-.992)	(5.75)	[.874; .0553]	[.644; 2.33]	<-.577E-4>			
XD/WG ; THE/DB	-0.00576	(0)	(0)	(.0699)	(.0910)	(.136)	(2.59)	[-.272; .179]	[.647; 2.33]	[.733; 3.23]	<-.236E-4>			
XD/WG ; PSI/DP	-0.00772	(0)	(.0794)	(.178)	(.318)	(.594)	(-1.06)	(4.01)	(.64)	[-.208; .211]	[.777; 3.59]	<.000494>		
ZD/WG ; PHI/DA	-.175	(0)	(.0644)	(.245)	(.784)	(2.59)	(5.75)	[.836; .0552]	[-.0725; .132]	[.646; 2.30]	<.905E-5>			
ZD/WG ; THE/DB	-.0551	(0)	(.0169)	(.0699)	(.0904)	(.144)	(2.59)	[-.297; .200]	[.651; 2.34]	[.734; 3.23]	<-.502E-5>			
ZD/WG ; PSI/DP	-.302	(.0794)	(.213)	(.225)	(.782)	(2.44)	(4.01)	[.229; .193]	[-.538; .221]	[.734; 3.43]	<-.000188>			
XD/UG ; ZD/DC	-.178	(0)	(.0789)	(.262)	(.927)	(3.52)	[.772; .259]	[-.239; .377]	[.907; 2.29]	[.504; 2.44]	<-.00355>			
YD/VG ; ZD/DC	-.649	(0)	(.0766)	(.242)	(.805)	(2.55)	[.0469; .133]	[.782; .449]	[.531; 1.97]	[.515; 3.22]	<-.00355>			
PHI/UG ; THE/DB ; PSI/DP	-0.000966	(0)	(.0209)	(.0699)	(.0794)	(.370)	(.454)	(1.00)	(2.59)	(4.01)	<-.195E-6>			
THE/UG ; PHI/DA ; PSI/DP	-0.000158	(0)	(.0217)	(.0644)	(.0794)	(.417)	(.435)	(1.35)	(4.01)	(5.75)	<.990E-7>			
PSI/UG ; PHI/DA ; THE/DB	-0.000116	(0)	(.00215)	(.0644)	(.0699)	(.106)	(.541)	(.588)	(2.59)	(5.75)	<-.561E-9>			
PHI/VG ; THE/DB ; PSI/DP	.000700	(0)	(.0180)	(.0699)	(.0794)	(.309)	(.370)	(1.00)	(2.59)	(4.01)	<.832E-7>			
THE/VG ; PHI/DA ; PSI/DP	.000491	(0)	(-.00744)	(.0644)	(.0794)	(.417)	(.435)	(.660)	(4.01)	(5.75)	<-.515E-7>			
PSI/VG ; PHI/DA ; THE/DB	.00112	(0)	(0)	(.0644)	(.0699)	(.418)	(.541)	(.588)	(2.59)	(5.75)	<.996E-5>			
PHI/WG ; THE/DB ; PSI/DP	.000616	(0)	(.0213)	(.0662)	(.0699)	(.0794)	(.370)	(1.00)	(2.59)	(4.01)	<.185E-7>			
THE/WG ; PHI/DA ; PSI/DP	-.00134	(0)	(.00993)	(.0310)	(.0644)	(.0794)	(.417)	(.435)	(4.01)	(5.75)	<-.872E-8>			
PSI/WG ; PHI/DA ; THE/DB	-.000309	(0)	(-.00128)	(.0448)	(.0644)	(.0699)	(.541)	(.588)	(2.59)	(5.75)	<.378E-9>			

TABLE IV-5 CONTINUED
AH-1G TRANSFER FUNCTION FACTORS

CASE 59 HOVER SCAS ON

GUST NUMERATORS CONCLUDED:

PHI/PG ; THE/DB ; PSI/DP	-.114	(-.00259)	(.0208)	(.0699)	(.0794)	(.370)	(.391)	(1.00)	(2.59)	(4.01)	<-.512E-7>	
THE/PG ; PHI/DA ; PSI/DP	-.0807	(0)	(.0132)	(.0644)	(.0794)	(.370)	(.417)	(.435)	(4.01)	(5.75)	<.131E-4>	
PSI/PG ; PHI/DA ; THE/DB	-.0236	(0)	(.0311)	(.0644)	(.0699)	(.392)	(.541)	(.588)	(2.59)	(5.75)	<-.614E-5>	
PHI/OG ; THE/DB ; PSI/DP	-.115	(.0148)	(.0214)	(.0699)	(.0794)	(.370)	(.387)	(1.00)	(2.59)	(4.01)	<.301E-6>	
THE/OG ; PHI/DA ; PSI/DP	-.0837	(.0644)	(.0794)	(.390)	(.417)	(.435)	(4.01)	(5.75)	[.973;.0144]	<-.149E-6>		
PSI/OG ; PHI/DA ; THE/DB	-.00327	(0)	(.0644)	(.0699)	(.0720)	(.340)	(.541)	(.588)	(2.59)	(5.75)	<.171E-5>	
PHI/RG ; THE/DB ; PSI/DP	-.0180	(.0151)	(.0230)	(.0699)	(.0794)	(.370)	(.454)	(1.00)	(2.59)	(4.01)	<.606E-7>	
THE/RG ; PHI/DA ; PSI/DP	-.00220	(0)	(.0644)	(.0794)	(.417)	(.435)	(4.01)	(5.75)	[.419;.0282]	<.374E-7>		
PSI/RG ; PHI/DA ; THE/DB	-.0369	(-.00107)	(.0150)	(.0644)	(.0699)	(.407)	(.541)	(.588)	(2.59)	(5.75)	<.545E-8>	
ID/UG ; PHI/DA ; THE/DB	-.000744	(0)	(-.0401)	(.0644)	(.0699)	(2.59)	(5.75)	[.847;.0517]	[.642;2.29]	<.282E-7>		
THE/UG ; PHI/DA ; PSI/DP	-.00554	(.0217)	(.0644)	(.0794)	(.325)	(.664)	(2.06)	(4.01)	(5.75)	[.129;.711]	<-.319E-5>	
ID/UG ; THE/DB ; PSI/DP	-.00124	(.0699)	(.0794)	(2.59)	(4.01)	[.959;.158]	[-.373;.366]	[.752;3.34]	<.268E-5>			
ZD/UG ; PHI/DA ; THE/DB	-.00793	(0)	(0)	(.0644)	(.0699)	(2.59)	(5.75)	[.841;.0549]	[.648;2.30]	<-.851E-5>		
ZD/UG ; PHI/DA ; PSI/DP	-.0451	(0)	(.00328)	(.0213)	(.0644)	(.0794)	(.224)	(.798)	(2.51)	(4.01)	(5.75)	<-.167E-6>
ZD/UG ; THE/DB ; PSI/DP	-.0138	(0)	(.0699)	(.0794)	(.197)	(2.59)	(4.01)	[-.238;.267]	[.749;3.30]	<.000122>		
YD/VG ; PHI/DA ; THE/DB	-.00286	(0)	(-.00103)	(.0560)	(.0644)	(.0699)	(.358)	(2.59)	(5.75)	[.598;1.72]	<.117E-7>	
YD/VG ; PHI/DA ; PSI/DP	-.00893	(.0644)	(.0794)	(.270)	(.353)	(.404)	(2.51)	(4.01)	(5.75)	[-.180;.125]	<-.319E-5>	
YD/VG ; THE/DB ; PSI/DP	-.00399	(.0180)	(.0699)	(.0794)	(.354)	(2.59)	(4.01)	[.785;.404]	[.472;3.34]	<.268E-5>		
ID/WG ; PHI/DA ; THE/DB	-.00269	(0)	(0)	(.0644)	(.0699)	(2.59)	(5.75)	[.826;.0538]	[.642;2.29]	<-.275E-5>		
THE/WG ; PHI/DA ; PSI/DP	-.0422	(0)	(.0253)	(.0644)	(.0794)	(.319)	(.595)	(-.979)	(4.01)	(5.75)	<.234E-4>	
ID/WG ; THE/DB ; PSI/DP	-.00468	(0)	(.0699)	(.0794)	(.143)	(2.59)	(4.01)	[-.278;.157]	[.748;3.31]	<.104E-4>		
ZD/WG ; PHI/DA ; THE/DB	-.0298	(0)	(0)	(.0644)	(.0699)	(2.59)	(5.75)	[.842;.0544]	[.647;2.30]	<-.314E-4>		
ZD/WG ; PHI/DA ; PSI/DP	-.145	(.0216)	(.0644)	(.0794)	(.245)	(.784)	(2.58)	(4.01)	(5.75)	[-.0718;.132]	<-.319E-5>	
ZD/WG ; THE/DB ; PSI/DP	-.0448	(.0193)	(.0699)	(.0794)	(.150)	(2.59)	(4.01)	[-.309;.181]	[.748;3.31]	<.268E-5>		
XD/UG ; ZD/DC ; PHI/DA	-.0820	(0)	(.0644)	(.914)	(1.62)	(5.75)	[-.954;.0333]	[.929;.221]	[.572;2.45]	<-.146E-4>		
XD/UG ; ZD/DC ; THE/DB	-.0206	(0)	(.0659)	(.0699)	(.216)	(2.59)	[-.201;.332]	[.627;2.30]	[.742;3.27]	<.000331>		
XD/UG ; ZD/DC ; PSI/DP	-.133	(.0794)	(.260)	(.913)	(4.01)	(4.02)	[.753;.264]	[-.161;.352]	[.767;2.44]	<.00207>		
YD/VG ; ZD/DC ; PHI/DA	-.221	(0)	(-.0542)	(.0644)	(.225)	(.798)	(2.53)	(5.75)	[.707;.0837]	[.589;1.82]	<.466E-4>	
YD/VG ; ZD/DC ; THE/DB	-.0960	(0)	(.0333)	(.0699)	(.0717)	(2.59)	[.759;.449]	[.559;1.98]	[.510;3.17]	<.000331>		
YD/VG ; ZD/DC ; PSI/DP	-.347	(.0794)	(.242)	(.806)	(2.70)	(4.01)	[.0812;.132]	[.772;.437]	[.466;3.28]	<.00207>		
ID/UG ; PHI/DA ; THE/DB ; PSI/DP	-.000612	(.0190)	(-.0403)	(.0644)	(.0699)	(.0794)	(2.59)	(4.01)	(5.75)	<-.100E-7>		
ZD/UG ; PHI/DA ; THE/DB ; PSI/DP	-.00655	(0)	(.0215)	(.0644)	(.0699)	(.0794)	(2.59)	(4.01)	(5.75)	<.300E-5>		
ID/VG ; PHI/DA ; THE/DB ; PSI/DP	-.00130	(-.00101)	(.0644)	(.0699)	(.0794)	(.358)	(2.59)	(4.01)	(5.75)	<-.100E-7>		
ID/WG ; PHI/DA ; THE/DB ; PSI/DP	-.00221	(0)	(.0196)	(.0644)	(.0699)	(.0794)	(2.59)	(4.01)	(5.75)	<.923E-6>		
ZD/WG ; PHI/DA ; THE/DB ; PSI/DP	-.0213	(-.00105)	(.0211)	(.0644)	(.0699)	(.0794)	(2.59)	(4.01)	(5.75)	<-.100E-7>		
XD/WG ; ZD/DC ; PHI/DA ; THE/DB	-.0101	(0)	(.0644)	(.0699)	(2.59)	(5.75)	[.739;.0576]	[.625;2.26]	<.115E-4>			
YD/VG ; ZD/DC ; PHI/DA ; THE/DB	-.0321	(0)	(.00718)	(.0546)	(.0644)	(.0699)	(2.59)	(5.75)	[.590;1.82]	<.280E-5>		
YD/VG ; ZD/DC ; PHI/DA ; PSI/DP	-.116	(.0644)	(.0794)	(.224)	(.798)	(2.51)	(4.01)	(5.75)	[.261;.0229]	<.322E-5>		
XD/WG ; ZD/DC ; PHI/DA ; THE/DB	-.0361	(0)	(.0644)	(.0699)	(2.59)	(5.75)	[.752;.0562]	[.625;2.27]	<.393E-4>			
ID/UG ; ZD/DC ; PHI/DA ; THE/DB ; PSI/DP	-.00821	(.0195)	(.0644)	(.0699)	(.0794)	(2.59)	(4.01)	(5.75)	<-.341E-5>			
YD/VG ; ZD/DC ; PHI/DA ; THE/DB ; PSI/DP	-.0168	(.00951)	(.0644)	(.0699)	(.0794)	(2.59)	(4.01)	(5.75)	<-.341E-5>			
ID/WG ; ZD/DC ; PHI/DA ; THE/DB ; PSI/DP	-.0295	(.0193)	(.0644)	(.0699)	(.0794)	(2.59)	(4.01)	(5.75)	<-.122E-4>			

TABLE IV-5 CONTINUED
AH-IG TRANSFER FUNCTION FACTORS

CASE 61 20KT SCAS OFF

DENOMINATOR: (0) (.204) (1.04) [-.258; .326] [.828; .655] [.137; .698] <.00470>

CONTROL NUMERATORS:

PHI/DA .501 (0) [-.383; .313] [.929; .540] [.436; .696] <.00695>
 THE/DB -.158 (0) (.00828) (.199) (.516) (1.17) [.165; .701] <-.771E-4>
 PSI/DP -.733 (1.09) [.024; .265] [-.390; .330] [.822; .670] <-.00275>

PHI/DB .137 (0) (.748) [.104; .244] [.325; .669] <.00274>
 PHI/DP .291 (0) (-.384) (.740) [-.181; .275] [.771; .665] <-.00277>
 PHI/DC .0293 (0) [-.396; .331] [.986; .703] [.157; 1.74] <.00481>

THE/DA .100 (0) (.00527) (.214) (.550) [.205; .839] <.440E-4>
 THE/DP .0562 (0) (.0125) (.189) (.537) [.576; .866] <.535E-4>
 THE/DC .0334 (0) (.0183) (.215) (.907) (1.99) [-.0493; .691] <.000113>

PSI/DA .0341 (-.603) (-1.30) (-4.88) [-.281; .307] [.890; .725] <.00644>
 PSI/DB .00975 (-.462) (1.32) (-4.89) [-.0132; .328] [.732; .875] <.00240>
 PSI/DC .478 (1.02) [-.254; .297] [-.157; .497] [.872; .667] <.00470>

XD/DB 1.28 (0) (.202) (.491) (1.17) [.166; .701] [.0172; 2.01] <.296>
 YD/DA .863 [-.381; .317] [.924; .537] [.406; .684] [.0192; 4.31] <.217>
 ZD/DC -12.2 (0) (.0113) (.296) (1.07) [.214; .436] [.155; .666] <-.00366>

XD/DC -.101 (0) (.209) (.895) (2.05) [-.0415; .696] [-.0916; 3.20] <-.193>
 YD/DP 1.36 (-.437) (.728) [-.183; .279] [.764; .666] [.0651; 2.49] <-.0929>
 ZD/DB .883 (0) (.193) (-.455) (1.18) [.147; .686] [.0622; 1.80] <-.140>

PHI/DA ; THE/DB -.0791 (0) (.00750) (.534) [.455; .664] <-.000140>
 PHI/DA ; PSI/DP -.377 (.0348) [-.330; .268] [.870; .538] <-.000274>
 THE/DB ; PSI/DP .116 (.00544) (.509) (1.19) [.0167; .216] <.178E-4>

PHI/DB ; PSI/DP -.0879 (.0340) (.753) [-.0571; .292] <-.000192>
 PHI/DP ; THE/DB -.0459 (0) (.00486) (-.175) (.496) (.733) <.142E-4>
 PHI/DC ; THE/DB -.00482 (0) (.0110) (.714) [.433; 1.95] <-.000145>

THE/DA ; PSI/DP -.0754 (.00920) (.550) [.00418; .510] <-.990E-4>
 THE/DP ; PHI/DA .000274 (0) (.00928) (.546) [-.336; 8.70] <.000105>
 THE/DC ; PHI/DA .0168 (0) (.248) (1.61) [.120; .134] <.000122>

PSI/DA ; THE/DB -.00536 (.00752) (.545) (1.01) (-1.18) (-4.88) <-.000128>
 PSI/DB ; PHI/DA .00469 (.0330) (.335) (-4.89) [-.0647; .911] <-.000210>
 PSI/DC ; THE/DB -.0758 (.0109) (.651) (1.16) [-.202; .466] <-.000135>

PSI/DC ; PHI/DA .238 (.0400) [-.343; .320] [.901; .609] <.000362>
 XD/DB ; PHI/DA .641 (0) (.513) [.454; .664] [.0177; 2.01] <.589>
 XD/DB ; PSI/DP -.938 (.486) (1.19) [.0153; .216] [.0183; 2.01] <-.103>

YD/DA ; THE/DB -.136 (.00753) (.533) [.413; .653] [.0197; 4.31] <-.00432>
 YD/DA ; PSI/DP -.679 [-.330; .269] [.867; .539] [-.0149; 4.23] <-.255>
 ZD/DC ; PHI/DA -6.09 (0) (.534) [-.411; .281] [.340; .711] <-.130>

ZD/DC ; THE/DB 1.89 (0) (.0185) (.181) (1.17) [.120; .679] <.00341>
 ZD/DC ; PSI/DP 8.94 (-.114) (1.17) [-.158; .379] [.521; .484] <-.0401>
 XD/DC ; PHI/DA -.0515 (0) (1.56) [.790; .159] [-.122; 3.20] <-.0209>

XD/DC ; THE/DB -.0268 (0) (.139) (1.19) (1.76) [.0938; .711] <-.00394>
 XD/DC ; PSI/DP .0993 (.793) (3.25) [-.0208; .365] [-.0194; 2.73] <.252>
 YD/DP ; PHI/DA .431 (.990) (-1.07) [-.339; .265] [.837; .538] <-.00924>

YD/DP ; THE/DB -.215 (.00553) (-.234) (.494) (.718) [.0656; 2.47] <.000602>
 ZD/DB ; PHI/DA .442 (0) (-.443) [.470; .677] [.0464; 1.76] <-.277>
 ZD/DB ; PSI/DP -.646 (-.456) (1.20) [.00995; .228] [.0465; 1.81] <.0602>

PHI/DA ; THE/DB ; PSI/DP .0595 (.00806) (.0342) (.529) <.863E-5>
 PHI/DC ; THE/DB ; PSI/DP .0256 (.0146) (.0322) (.717) <.863E-5>
 THE/DC ; PHI/DA ; PSI/DP -.0128 (.0162) (.0418) (1.19) <-.103E-4>

TABLE IV-5 CONTINUED
AH-IG TRANSFER FUNCTION FACTORS

CASE 61 20KT SCAS OFF

CONTROL NUMERATORS CONCLUDED:

PSI/DC ; PHI/DA ; THE/DB - .0378 (.00385) (.0392) (.630) <-.359E-5>

 XD/DB ; PHI/DA ; PSI/DP - .482 (.0342) (.508) [.0184; 2.01] <-.0340>
 YD/DA ; THE/DB ; PSI/DP .107 (.00807) (.528) [-.0136; 4.23] <.00816>
 ZD/DC ; PHI/DA ; THE/DB .947 (0) (.0210) [-.438; .612] <.00747>

 ZD/DC ; THE/DB ; PSI/DP -1.39 (.0194) (1.20) [-.0551; .270] <-.00235>
 XD/DC ; PHI/DA ; PSI/DP 4.60 (.0554) (-.0578) [.395; .358] <-.00189>
 XD/DC ; PHI/DA ; THE/DB - .0134 (0) (1.79) [-.363; .642] <-.00990>

 XD/DC ; PHI/DA ; PSI/DP .0544 (.0398) (1.06) [-.184; 2.91] <.0195>
 XD/DC ; THE/DB ; PSI/DP .0152 (1.23) (2.34) [-.0631; .254] <.00282>
 YD/DP ; PHI/DA ; THE/DB - .0680 (.00806) (.523) (.955) (-1.07) <.000293>

 ZD/DB ; PHI/DA ; PSI/DP - .332 (.0343) (-.415) [-.0413; 1.78] <.0150>

 ZD/DC ; PHI/DA ; THE/DB ; PSI/DP - .715 (.0199) (.0354) <-.000502>
 XD/DC ; PHI/DA ; THE/DB ; PSI/DP .00779 (.0349) (2.43) <.000659>

GUST NUMERATORS:

PHI/UG - .00380 (0) (0) (0) (-.222) (.888) [.582; .559] <.000234>
 THE/UG - .000394 (0) (0) (.203) (.890) (3.60) [.287; .754] <-.000146>
 PSI/UG - .00630 (0) (0) (1.08) [-.473; .269] [.756; .682] <.000229>

 PHI/VG .00672 (0) (0) (.529) [-.248; .315] [.842; .645] <.000146>
 THE/VG - .00156 (0) (0) (-.00306) (.275) [.864; .592] <.460E-6>
 PSI/VG - .0118 (0) (0) (1.13) [-.261; .321] [.826; .651] <-.000580>

 PHI/WG .00180 (0) (0) (.396) [-.861; .336] [-.130; .825] <.549E-4>
 THE/WG .00188 (0) (0) (.0276) (.207) (1.44) [.112; .703] <.767E-5>
 PSI/WG .00407 (0) [-.276; .258] [-.0589; .652] [.985; .713] <.583E-4>

 PHI/PG .977 (0) [-.276; .315] [.897; .630] [.415; .724] <.0201>
 THE/PG - .203 (0) (-.00323) (.241) (-.263) (.590) [-.356; .786] <-.152E-4>
 PSI/PG .429 (.836) [-.248; .320] [.854; .680] [-.545; 1.04] <.0185>

 PHI/QG .842 (0) (.311) (.549) [-.625; .286] [.449; .695] <.00568>
 THE/QG .226 (0) (.0104) (.206) (.532) (1.89) [.165; .765] <.000285>
 PSI/QG - .191 (.304) (-.725) (2.57) [-.331; .275] [.867; .811] <.00539>

 PHI/RG - .0257 (0) (1.66) (-2.47) [-.250; .313] [.875; .691] <.00493>
 THE/RG - .00638 (-.0111) (-.275) (-.759) [-1.00; .00112] [.250; 2.07] <.786E-4>
 PSI/RG .559 (1.02) [-.213; .331] [-.219; .417] [.840; .659] <.00470>

 XD/UG .0212 (0) (.204) (.846) (1.56) [-.305; .735] [-.225; 1.23] <.00470>
 ZD/UG .235 (0) (0) (.193) (1.08) [-.494; .438] [.117; .723] <.00493>
 YD/VG .0607 (0) (.537) [-.249; .315] [.842; .642] [-.144; 1.87] <.00470>

 XD/WG .00585 (0) (0) (.206) (-3.15) [-.115; .703] [.997; 2.17] <-.00885>
 ZD/WG .508 (0) (.202) [-.270; .362] [.140; .699] [.977; .846] <.00470>

 PHI/UG ; THE/DB .000603 (0) (0) (.886) [-.381; .400] <.853E-4>
 PHI/UG ; PSI/DP .000953 (0) (0) (.0282) (-.0728) (1.20) <-.235E-5>
 THE/UG ; PHI/DA - .000208 (0) (0) (.910) [-.559; 1.07] <-.000216>

 THE/UG ; PSI/DP .000295 (0) (1.16) (2.31) [-.0397; .328] <.855E-4>
 PSI/UG ; PHI/DA .00329 (0) (0) (.0396) [-.802; .364] <.172E-4>
 PSI/UG ; THE/DB - .000992 (0) (-.263) (1.19) [-.719; .490] <.747E-4>

 PHI/VG ; THE/DB - .00105 (0) (0) (.00826) [-.979; .525] <-.240E-5>
 PHI/VG ; PSI/DP - .00149 (0) [-.167; .295] [.835; .813] <-.856E-4>
 THE/VG ; PHI/DA - .000763 (0) (0) (.00531) (.454) (.743) <-.137E-5>

 THE/VG ; PSI/DP .00113 (0) (0) (.0102) [-.988; .739] <.633E-5>
 PSI/VG ; PHI/DA - .00614 (0) [-.319; .324] [.915; .557] <-.000200>
 PSI/VG ; THE/DB .00188 (0) (0) (.00755) (.538) (1.22) <.928E-5>

TABLE IV-5 CONTINUED
AH-IG TRANSFER FUNCTION FACTORS

CASE 61 20KT SCAS OFF

GUST NUMERATORS CONTINUED:

PHI/WG ; THE/DB	-.000296	(0)	(0)	(.0196)	[.360; .963]	<-.538E-5>
PHI/WG ; PSI/DP	-.00250	(0)	(.0829)	(-.317)	[.251; .183]	<.219E-5>
THE/WG ; PHI/DA	.000949	(0)	(0)	(.0356)	[.542; .566]	<.108E-4>
THE/WG ; PSI/DP	-.00138	(0)	(.0241)	(1.60)	[-.0456; .312]	<-.516E-5>
PSI/WG ; PHI/DA	.00198	(0)	(.0482)	(.644)	[-.321; .422]	<.109E-4>
PSI/WG ; THE/DB	-.000661	(0)	(.0192)	(1.12)	[-.259; .585]	<-.488E-5>
PHI/PG ; THE/DB	-.153	(0)	(.00752)	(.535)	[.427; .721]	<-.000320>
PHI/PG ; PSI/DP	-.840	(.0338)	(-.275;	.280)	[.858; .610]	<-.000825>
THE/PG ; PHI/DA	-.0990	(0)	(.00740)	(.534)	[.402; .732]	<-.000210>
THE/PG ; PSI/DP	.149	(.0102)	(.576)	(-.604)	[.465; .618]	<-.000202>
PSI/PG ; PHI/DA	.182	(.0199)	(.201)	(-.331)	[.618; .600]	<-.865E-4>
PSI/PG ; THE/DB	-.0658	(.00755)	(.541)	(1.06)	[-.493; 1.02]	<-.000296>
PHI/QG ; THE/DB	-.134	(0)	(.00951)	(.533)	[.484; .618]	<-.000260>
PHI/QG ; PSI/DP	-.561	(.0404)	(-.505;	.212)	[.965; .384]	<-.000150>
THE/QG ; PHI/DA	.115	(0)	(.0121)	(.533)	[.422; .703]	<.000368>
THE/QG ; PSI/DP	-.166	(.0109)	(.531)	(1.92)	[-.0591; .352]	<-.000228>
PSI/QG ; PHI/DA	-.124	(.0270)	(.262)	(-.464)	[.519; .675]	<.000186>
PSI/QG ; THE/DB	.0279	(.00949)	(.550)	(-.643)	(.915)	(2.73) <-.000234>
PHI/RG ; THE/DB	.00410	(0)	(.00823)	(.550)	(1.93)	(-2.25) <-.809E-4>
PHI/RG ; PSI/DP	-.144	(.0377)	(-.324;	.268)	[.892; .554]	<-.000119>
THE/RG ; PHI/DA	-.00327	(0)	(.00536)	(.520)	[-.0634; 2.25]	<-.461E-4>
THE/RG ; PSI/DP	.00526	(.0123)	(.620)	(-5.06)	[.0591; .514]	<-.535E-4>
PSI/RG ; PHI/DA	.281	(.0313)	(-.336;	.267)	[.867; .547]	<.000188>
PSI/RG ; THE/DB	-.0882	(.00823)	(.540)	(1.16)	[-.155; .412]	<-.771E-4>
XD/UG ; PHI/DA	.0107	(0)	(.722)	(.600;	.882)	[-.267; 1.07] <.00695>
XD/UG ; THE/DB	-.00285	(0)	(1.17)	(.927;	.227)	[.159; .683] <-.771E-4>
XD/UG ; PSI/DP	-.0152	(-.0346;	.331)	(-.160;	1.10)	[.992; 1.17] <-.00275>
ZD/UG ; PHI/DA	.118	(0)	(0)	[.252;	.367]	[.519; .677] <.00729>
ZD/UG ; THE/DB	-.0368	(0)	(.193)	(1.17)	[.180; .728]	<-.00442>
ZD/UG ; PSI/DP	-.172	(0)	(1.08)	(-.192;	.344)	[.650; .363] <-.00289>
YD/VG ; PHI/DA	.0246	(0)	(.445)	(-.311;	.266)	[.860; .493] <.000188>
YD/VG ; THE/DB	-.00956	(0)	(.00826)	(.978;	.532)	[.185; 1.86] <-.771E-4>
YD/VG ; PSI/DP	-.0284	(-.171;	.299)	(.864;	.837)	[.190; 1.24] <-.00275>
XD/WG ; PHI/DA	.00288	(0)	(0)	(-2.96)	(3.45)	[.541; .585] <-.0101>
XD/WG ; THE/DB	-.00334	(0)	(0)	(.177)	(1.16)	[.155; .702] <-.000338>
XD/WG ; PSI/DP	-.00408	(0)	(-3.47)	(-.0469;	.310)	[.944; 2.25] <.00690>
ZD/WG ; PHI/DA	.255	(0)	(.521)	(-.376;	.337)	[.449; .679] <.00695>
ZD/WG ; THE/DB	-.0819	(0)	(.00843)	(.197)	(1.17)	[.173; .698] <-.771E-4>
ZD/WG ; PSI/DP	-.372	(.0571;	.276)	(-.414;	.358)	[.978; .869] <-.00275>
XD/VG ; ZD/DC	-.235	(0)	(.0275)	(1.32)	[.865; .697]	[-.345; .939] <-.00366>
YD/VG ; ZD/DC	-.717	(0)	(.0151)	(.559)	[.374; .405]	[.151; 1.92] <-.00366>
PHI/UG ; THE/DB ; PSI/DP	-.000153	(0)	(.0340)	(1.14)	<-.597E-5>	
THE/UG ; PHI/DA ; PSI/DP	.000155	(0)	(.0348)	(1.58)	<.851E-5>	
PSI/UG ; PHI/DA ; THE/DB	-.000517	(0)	(.0330)	(.383)	<-.654E-5>	
PHI/VG ; THE/DB ; PSI/DP	.000224	(0)	(.00545)	(.454)	<.555E-6>	
THE/VG ; PHI/DA ; PSI/DP	.000578	(0)	(.00919)	(.579)	<.308E-5>	
PSI/VG ; PHI/DA ; THE/DB	.000976	(0)	(.00752)	(.543)	<.398E-5>	
PHI/WG ; THE/DB ; PSI/DP	.000409	(0)	[.959;	.0291]	<.345E-6>	
THE/WG ; PHI/DA ; PSI/DP	-.000715	(0)	(.0182)	(.0455)	<-.592E-6>	
PSI/WG ; PHI/DA ; THE/DB	-.000321	(0)	(-.00663)	(.0509)	<.108E-6>	

TABLE IV-5 CONTINUED
AH-IG TRANSFER FUNCTION FACTORS

CASE 61 20KT SCAS OFF

GUST NUMERATORS CONCLUDED:

PHI/PG ; THE/DB ; PSI/DP	.131	(.00824)	(.0339)	(.531)	<.194E-4>
THE/PG ; PHI/DA ; PSI/DP	.0744	(.00757)	(.0325)	(.524)	<.956E-5>
PSI/PG ; PHI/DA ; THE/DB	-.0277	(.00737)	(.0421)	(.536)	<-.461E-5>
PHI/QG ; THE/DB ; PSI/DP	.0902	(.0102)	(.0347)	(.526)	<.169E-4>
THE/QG ; PHI/DA ; PSI/DP	-.0868	(.0116)	(.0328)	(.524)	<-.173E-4>
PSI/QG ; PHI/DA ; THE/DB	.0185	(.0155)	(.0477)	(.539)	<.741E-5>
PHI/RG ; THE/DB ; PSI/DP	.0226	(.0101)	(.0353)	(.561)	<.450E-5>
THE/RG ; PHI/DA ; PSI/DP	.00230	(-.0745)	[.689 ; .0770]	<-.102E-5>	
PSI/RG ; PHI/DA ; THE/DB	-.0443	(.00676)	(.0319)	(.542)	<-.517E-5>
XD/UG ; PHI/DA ; THE/DB	-.00143	(0)	(-.236)	[.446 ; .643]	<-.000140>
XD/UG ; PHI/DA ; PSI/DP	.000787	(0)	(.0348)	(.951)	[-.146 ; 1.03] <.274E-4>
XD/UG ; THE/DB ; PSI/DP	.00203	(.168)	(1.19)	[.150 ; .209]	<.178E-4>
ZD/UG ; PHI/DA ; THE/DB	-.0184	(0)	(0)	[.479 ; .689]	<-.00876>
ZD/UG ; PHI/DA ; PSI/DP	-.0886	(0)	(.0346)	[.373 ; .306]	<-.000287>
ZD/UG ; THE/DB ; PSI/DP	.0269	(0)	(1.19)	[-.0387 ; .243]	<.00189>
YD/VG ; PHI/DA ; THE/DB	-.00388	(0)	(.00675)	(.415)	(.476) <-.517E-5>
YD/VG ; PHI/DA ; PSI/DP	-.0132	[-.340 ; .264]	[.843 ; .544]	<-.000274>	
YD/VG ; THE/DB ; PSI/DP	.00445	(.00543)	(.440)	[.425 ; 1.29]	<.178E-4>
XD/WG ; PHI/DA ; THE/DB	-.00167	(0)	(0)	[.447 ; .654]	<-.000715>
XD/WG ; PHI/DA ; PSI/DP	-.00204	(0)	(.0416)	(-3.05)	(3.69) <.000958>
XD/WG ; THE/DB ; PSI/DP	.00241	(0)	(1.18)	[-.0267 ; .227]	<.000147>
ZD/WG ; PHI/DA ; THE/DB	-.0410	(0)	(.00764)	[.467 ; .668]	<-.000140>
ZD/WG ; PHI/DA ; PSI/DP	-.191	(.0345)	(.451)	[-.328 ; .303]	<-.000274>
ZD/WG ; THE/DB ; PSI/DP	.0600	(.00559)	(1.19)	[-.00844 ; .212]	<.178E-4>
XD/UG ; ZD/DC ; PHI/DA	-.119	(0)	[-.603 ; .860]	[.686 ; 1.22]	<-.130>
XD/UG ; ZD/DC ; THE/DB	.0404	(0)	(.154)	(1.17)	[.0879 ; .684] <.00341>
XD/UG ; ZD/DC ; PSI/DP	.163	(-.857)	[-.00581 ; .405]	[.766 ; 1.32]	<-.0401>
YD/VG ; ZD/DC ; PHI/DA	-.287	(0)	(-.118)	(.549)	[.196 ; .410] <.00314>
YD/VG ; ZD/DC ; THE/DB	.112	(0)	(.0187)	(.451)	[.185 ; 1.90] <.00341>
YD/VG ; ZD/DC ; PSI/DP	.363	(-.116)	[.578 ; .676]	[.210 ; 1.44]	<-.0401>
XD/UG ; PHI/DA ; THE/DB ; PSI/DP	.00104	(.0341)	(.244)	<.868E-5>	
ZD/UG ; PHI/DA ; THE/DB ; PSI/DP	.0138	(0)	(.0343)	<.000475>	
YD/VG ; PHI/DA ; THE/DB ; PSI/DP	.00208	(.00806)	(.518)	<.868E-5>	
XD/WG ; PHI/DA ; THE/DB ; PSI/DP	.00124	(0)	(.0349)	<.431E-4>	
ZD/WG ; PHI/DA ; THE/DB ; PSI/DP	.0309	(.00821)	(.0343)	<.868E-5>	
XD/UG ; ZD/DC ; PHI/DA ; THE/DB	.0203	(0)	[.379 ; .607]	<.00747>	
YD/VG ; ZD/DC ; PHI/DA ; THE/DB	.0449	(0)	(.0173)	(.333)	<.000258>
YD/VG ; ZD/DC ; PHI/DA ; PSI/DP	.163	(-.0758)	[.399 ; .392]	<-.00189>	
XD/WG ; ZD/DC ; PHI/DA ; THE/DB	.0270	(0)	[.369 ; .606]	<.00990>	
XD/UG ; ZD/DC ; PHI/DA ; THE/DB ; PSI/DP	-.0144	(.0350)	<-.000502>		
YD/VG ; ZD/DC ; PHI/DA ; THE/DB ; PSI/DP	-.0251	(.0200)	<-.000502>		
XD/WG ; ZD/DC ; PHI/DA ; THE/DB ; PSI/DP	-.0189	(.0349)	<-.000659>		

TABLE IV-5 CONTINUED
AH-1G TRANSFER FUNCTION FACTORS

CASE 61 20KT SCAS ON

CONTROL NUMERATORS CONCLUDED:

PSI/DC ; PHI/DA ; THE/DB	- .0378 (.00385) (.0392) (.0644) (.0699) (.541) (.588) (.630) (2.59) (5.75) <- .767E-7>
XD/DB ; PHI/DA ; PSI/DP	- .482 (.0342) (.0644) (.0699) (.0794) (.508) (2.59) (4.01) (5.75) [.0184; 2.01] <- .00072E-6>
YD/DA ; THE/DB ; PSI/DP	.107 (.00807) (.0644) (.0699) (.0794) (.528) (2.59) (4.01) (5.75) [-.0116; 4.23] <- .00017E-6>
ZD/DC ; PHI/DA ; THE/DB	.947 (0) (.0210) (.0644) (.0699) (2.59) (5.75) [.519; .158] [-.610; 2.23] <- .00016E-6>
ZD/DC ; THE/DB ; PSI/DP	- 1.39 (.0134) (.0699) (.0794) (.140) (2.59) (4.01) [-.239; .139] [-.771; 3.46] <- .502E-4>
ZD/DC ; PHI/DA ; PSI/DP	4.60 (-.0332) (.0644) (.0794) (.200) (.811) (2.65) (4.01) (5.75) [.975; .0723] <- .403E-4>
XD/DC ; PHI/DA ; THE/DB	- .0134 (0) (.0644) (.0699) (2.04) (2.59) (5.75) [.514; .162] [-.498; 2.13] <- .00022E-6>
XD/DC ; PHI/DA ; PSI/DP	.0544 (.0397) (.0644) (.0794) (.323) (.606) (1.30) (4.01) (5.75) [-.754; 2.53] <- .00041E-5>
XD/DC ; THE/DB ; PSI/DP	.0152 (.0699) (.0794) (.136) (2.40) (2.59) (4.01) [-.247; .132] [-.764; 3.47] <- .602E-4>
YD/DP ; PHI/DA ; THE/DB	- .0680 (.00806) (.0644) (.0699) (.0794) (.523) (.955) (-1.07) (2.59) (4.01) (5.75) <- .625E-5>
ZD/DB ; PHI/DA ; PSI/DP	- .332 (.0343) (.0644) (.0699) (.0794) (-.415) (2.59) (4.01) (5.75) [.0413; 1.78] <- .00032E-6>
ZD/DC ; PHI/DA ; THE/DB ; PSI/DP	- .715 (.0199) (.0354) (.0644) (.0699) (.0794) (2.59) (4.01) (5.75) <- .107E-4>
XD/DC ; PHI/DA ; THE/DB ; PSI/DP	.00779 (.0349) (.0644) (.0699) (.0794) (2.43) (2.59) (4.01) (5.75) <- .141E-4>

GUST NUMERATORS:

PHI/UG	- .00380 (0) (0) (0) (.213) (.371) (.837) (2.62) [-.543; .134] [.971; .945] [.615; 1.53] <- .246E-4>
THE/UG	- .000394 (0) (0) (.418) (.433) (1.40) [-.922; .114] [.191; .218] [.413; 2.22] [.965; 3.93] <- .465E-5>
PSI/UG	.00630 (0) (0) (-.143) (.224) (.382) (.529) (.613) (.799) (2.65) [.664; .174] [.779; 3.53] <- .199E-4>
PHI/VG	.00672 (0) (0) (.0883) (.283) (.822) (.922) (2.87) [-.103; .162] [.999; .431] [.666; 1.62] <- .465E-5>
THE/VG	- .00156 (0) (0) (.03654) (.0236) (.0938) (.580) [-.000; .428] [.771; 2.23] [.573; 3.40] <- .124E-6>
PSI/VG	- .0118 (0) (0) (.0444) (.256) (.526) (.554) (.590) (.803) (2.73) [-.0897; .140] [.779; 3.53] <- .124E-4>
PHI/WG	- .000180 (0) (0) (.216) (.365) (.837) (1.07) (2.13) [-.368; .101] [.664; .214] [.576; 2.98] <- .111E-6>
THE/WG	.00188 (0) (0) (.0256) (.101) (.123) (.425) (.427) [-.0137; .196] [.654; 2.36] [.765; 3.33] <- .258E-6>
PSI/WG	.00407 (0) (.169) (.265) (.528) (.657) (.686) (2.85) [-.0187; .102] [-.185; .789] [.727; 3.41] <- .124E-5>
PHI/PG	.977 (0) (.263) (.369) (.527) (.828) (1.00) (2.88) [-.158; .143] [.565; .811] [.620; 2.35] <- .00043E-6>
THE/PG	- .203 (0) (.00666) (.0614) (-.173) (.413) (.438) (.522) [.630; .239] [.600; 2.28] [.637; 3.14] <- .395E-5>
PSI/PG	.429 (.522) (1.00) (2.33) [-.0438; .154] [-.992; .263] [-.220; .423] [.999; .556] [.648; 2.89] <- .00039E-5>
PHI/QG	.842 (0) (.233) (.372) (.523) (.834) (1.01) (2.49) [-.242; .106] [.643; .171] [.615; 2.17] <- .00012E-6>
THE/QG	.226 (0) (.0104) (.415) (.436) (.525) [-.995; .117] [.0445; .232] [.601; 2.27] [.838; 3.52] <- .104E-4>
PSI/QG	- .191 (.226) (-.442) (.521) (1.20) (1.91) [-.0507; .106] [.878; .288] [.998; .550] [.928; 4.23] <- .00011E-5>
PHI/RG	- .0257 (0) (.256) (.358) (.551) (.829) (1.07) (-.978) [-.191; .148] [.587; .235] [.982; 2.78] <- .00010E-6>
THE/RG	- .00638 (0) (.00981) (.0552) (-.261) (.300) [.999; .436] [.734; .762] [-.887; 1.54] [.813; 3.99] <- .112E-5>
PSI/RG	.559 (.187) (.249) (.525) (.563) (.572) (.839) (2.64) [-.0465; .155] [-.381; .190] [.755; 3.44] <- .00010E-6>
XD/UG	.0212 (0) (.351) (.640) (2.32) [-.925; .114] [-.183; .226] [.257; .588] [.596; 2.42] [.824; 3.17] <- .00015E-6>
ZD/UG	.235 (0) (0) (.0651) (.209) (.805) (2.64) [.799; .110] [.0807; .177] [.629; 2.32] [.748; 3.36] <- .00015E-6>
YD/VG	.0607 (0) (.0875) (.263) (.516) (.840) (2.74) [-.156; .167] [-.562; .286] [.664; 1.87] [.577; 3.36] <- .00015E-6>
XD/WG	.00585 (0) (0) (.317) (.596) (-.966) (9.96) [-.987; .112] [.0199; .196] [.626; 2.34] [.764; 3.43] <- .00032E-4>
ZD/WG	.508 (0) (.242) (.779) (2.76) [-.904; .197] [-.310; .161] [-.346; .177] [.623; 2.30] [.747; 3.39] <- .00015E-6>
PHI/UG ; THE/DB	.000603 (0) (0) (.0699) (.371) (2.59) [-.512; .145] [.977; .972] [.591; 1.54] <- .190E-5>
PHI/UG ; PSI/DP	.000953 (0) (0) (.0343) (.0794) (.215) (.370) (.866) (1.00) (1.05) (2.57) (4.01) <- .193E-5>
THE/UG ; PHI/DA	- .000208 (0) (0) (.0644) (.418) (.433) (1.37) (5.75) [.567; .202] [.442; 2.45] <- .468E-5>
THE/UG ; PSI/DP	.000295 (0) (.0794) (.166) (.417) (.435) (1.61) (4.01) [-.213; .179] [.853; 3.54] <- .183E-5>
PSI/UG ; PHI/DA	.00329 (0) (0) (.0339) (.0644) (.232) (.383) (.529) (.613) (.800) (2.68) (5.75) <- .254E-5>
PSI/UG ; THE/DB	- .000992 (0) (.0699) (-.165) (.382) (.541) (.588) (2.59) [-.636; .190] [-.779; 3.50] <- .159E-5>
PHI/VG ; THE/DB	- .00105 (0) (0) (.00784) (.0699) (.0928) (.918) (2.59) [.999; .431] [.682; 1.57] <- .585E-7>
PHI/VG ; PSI/DP	- .00149 (0) (.0794) (.299) (.170) (.452) (.818) (1.00) (1.14) (4.01) [-.119; .171] <- .183E-5>
THE/VG ; PHI/DA	- .000763 (0) (0) (.00703) (.0644) (.0821) (.579) (5.75) [.000; .428] [.704; 2.30] <- .912E-7>
THE/VG ; PSI/DP	- .00113 (0) (0) (.0107) (.0285) (.0794) (.417) (.435) (.580) (4.01) [-.743; 3.41] <- .135E-6>
PSI/VG ; PHI/DA	- .00614 (0) (.0644) (.256) (.526) (.553) (.591) (.802) (2.78) (5.75) [-.0715; .138] <- .427E-5>
PSI/VG ; THE/DB	.00138 (0) (0) (.00756) (.0366) (.0699) (.541) (.543) (.588) (2.59) [-.780; 3.49] <- .198E-6>

TABLE IV-5 CONTINUED
AH-IG TRANSFER FUNCTION FACTORS

CASE 61 20KT SCAS ON

GUST NUMERATORS CONTINUED:

PRI/WG ; THE/DR	- .00796 (0) (.0197) (.0699) (.165) (1.03) (2.59) (.517; .191) [.639; 2.88] [-.119E-6>
PRI/WG ; PSI/DP	- .00750 (0) (-.0673) (.0794) (.207) (.170) (.851) (1.00) (2.76) (4.01) [.842; .0754] [-.468E-7>
THE/WG ; PHI/DA	- .000949 (0) (0) (-.0354) (.0644) (.425) (.428) (5.75) [.537; .143] [-.640; 2.26] [-.218E-6>
THE/WG ; PSI/DP	- .00138 (0) (.0240) (.0794) (.163) (.417) (.435) (4.01) [-.218; .168] [.813; 3.54] [-.110E-6>
PSI/WG ; PHI/DA	- .00198 (0) (.0483) (.0644) (.267) (.528) (.656) (.687) (2.99) (5.75) [-.0793; .188] [-.233E-6>
PSI/WG ; THE/DR	- .000661 (0) (.0192) (.0699) (-.195) (-.541) (-.588) (2.59) [-.250; .259] [.733; 3.30] [-.104E-6>
PRI/PG ; THE/DB	- .151 (0) (.00754) (.0699) (.369) (.531) (1.01) (2.59) [-.520; .175] [.618; 2.37] [-.709E-5>
PHI/PG ; PSI/DP	- .840 (.0138) (.0794) (.262) (.370) (.527) (.625) (1.00) (2.81) (4.01) [-.0895; .129] [-.176E-4>
THE/PG ; PHI/DA	- .0990 (0) (.00740) (.0644) (.413) (.438) (.524) (5.75) [.509; .188] [.597; 2.74] [-.457E-5>
THE/PG ; PSI/DP	.149 (.0102) (.0794) (-.243) (.417) (.435) (.522) (4.01) [.686; .193] [.645; 3.22] [-.431E-5>
PSI/PG ; PHI/DA	- .182 (.0196) (.0644) (-.173) (.132) (.231) (.522) (1.00) (2.32) (5.75) [.999; .555] [-.185E-5>
PSI/PG ; THE/DB	- .0658 (.00755) (.0699) (-.250) (-.541) (-.588) (2.59) [-.175; .443] [-.636; 2.90] [-.632E-5>
PRI/QG ; THE/DB	- .134 (0) (.00953) (.0699) (-.372) (-.526) (.994) (2.59) [.532; .165] [.618; 2.16] [-.576E-5>
PHI/QG ; PSI/DP	- .561 (.0394) (.0794) (.232) (.370) (.523) (.841) (1.00) (2.52) (4.01) [-.0581; .0690] [-.319E-5>
THE/QG ; PHI/DA	.115 (0) (.0121) (.0644) (.474) (.477) (.524) (5.75) [.512; .180] [-.606; 2.25] [-.804E-5>
THE/QG ; PSI/DP	- .166 (.0109) (.0794) (-.178) (.417) (.435) (.525) (4.01) [-.217; .197] [.846; 3.60] [-.487E-5>
PSI/QG ; PHI/DA	- .124 (.0269) (.0644) (-.186) (.522) (1.21) (1.96) (5.75) [.979; .214] [.998; .551] [-.396E-5>
PSI/QG ; THE/DB	.0279 (.00949) (.0699) (-.402) (-.538) (-.541) (-.588) (2.59) [.819; .293] [-.955; 4.20] [-.499E-5>
PRI/RG ; THE/DB	.00410 (0) (.00826) (.0699) (.357) (.561) (1.08) (2.59) (2.83) [-.9.62] [.527; .222] [-.179E-5>
PHI/RG ; PSI/DP	- .144 (.0376) (.0794) (.251) (.370) (.551) (.828) (1.00) (2.72) (4.01) [-.0778; .113] [-.255E-5>
THE/RG ; PHI/DA	- .00327 (0) (.00527) (.0644) (.288) (5.75) [.998; .436] [.667; .732] [-.543; 2.24] [-.944E-6>
THE/RG ; PSI/DP	.00526 (.0123) (.0794) (.274) (.417) (.435) (-2.29) (4.01) [.349; .396] [.336; 1.76] [-.114E-5>
PSI/RG ; PHI/DA	- .281 (.0313) (.0644) (-.253) (-.525) (-.563) (.572) (.839) (2.69) (5.75) [-.0896; .113] [-.401E-5>
PSI/RG ; THE/DB	- .0882 (.00823) (.0699) (.167) (.541) (.542) (.588) (2.59) [-.253; .194] [-.756; 3.40] [-.165E-5>
ID/UG ; PHI/DA	.0107 (0) (.0644) (.351) (.641) (2.16) (5.75) [.575; .206] [-.248; .597] [.618; 2.31] [-.000151>
ID/UG ; THE/DB	- .00285 (0) (.0699) (.247) (2.59) [.720; .101] [.211; .159] [.615; 2.26] [.751; 3.35] [-.188E-5>
ID/UG ; PSI/DP	- .0152 (.0794) (.167) (.351) (.640) (2.42) (4.01) [-.248; .181] [-.341; .589] [.787; 3.44] [-.587E-4>
ZD/UG ; PHI/DA	.118 (0) (0) (.0544) (.0644) (.209) (.806) (2.67) (5.75) [.501; .170] [-.622; 2.27] [-.000158>
ZD/UG ; THE/DB	- .0358 (0) (0) (.0699) (2.59) [.837; .100] [.178; .173] [.630; 2.32] [.745; 3.33] [-.000119>
ZD/UG ; PSI/DP	- .172 (0) (.0794) (.212) (.806) (2.64) (4.01) [-.988; .101] [-.312; .142] [.772; 3.49] [-.616E-4>
YD/VG ; PHI/DA	.0246 (0) (.0588) (.0644) (-.256) (-.512) (.840) (2.71) (5.75) [-.0725; .109] [.614; 1.86] [-.654E-5>
YD/VG ; THE/DB	- .00956 (0) (.00784) (.0699) (.0907) (.522) (2.59) [.491; .271] [.671; 1.88] [.577; 3.36] [-.188E-5>
YD/VG ; PSI/DP	- .0284 (.0794) (.264) (.516) (.841) (2.75) (4.01) [-.237; .175] [-.572; .242] [.698; 3.39] [-.587E-4>
ID/VG ; PHI/DA	.0313 (0) (0) (.0644) (.318) (.597) (-.916) (5.75) [.552; .149] [.621; 2.26] [-.000231>
ID/VG ; THE/DB	- .00334 (0) (0) (.0699) (2.59) [.939; .0972] [.167; .166] [.619; 2.28] [.747; 3.33] [-.918E-5>
ID/VG ; PSI/DP	- .00408 (0) (.0794) (.162) (.317) (.596) (-.980) (4.01) (9.79) [-.184; .167] [-.797; 3.72] [-.165E-4>
ZD/VG ; PHI/DA	.255 (0) (.0644) (.244) (.779) (2.83) (5.75) [-.151; .135] [.589; .179] [.618; 2.25] [-.000151>
ZD/VG ; THE/DB	- .0819 (0) (.00800) (.0699) (2.59) [.807; .100] [.181; .163] [.625; 2.31] [.748; 3.33] [-.188E-5>
ZD/VG ; PSI/DP	- .372 (.0794) (.155) (.240) (.779) (2.76) (4.01) [-.512; .150] [-.225; .150] [.771; 3.51] [-.587E-4>
ID/UG ; ZD/DC	- .235 (0) (.0592) (-.108) (.748) (2.63) [-.976; .259] [-.249; .311] [-.565; 2.54] [-.856; 3.10] [-.00119>
YD/VG ; ZD/DC	- .717 (0) (-.0579) (.0976) (.816) (2.73) [.964; .180] [.492; .319] [-.652; 1.87] [.573; 3.37] [-.00119>
PRI/UG ; THE/DB ; PSI/DP	- .000153 (0) (.0340) (.0699) (.0794) (-.370) (1.00) (1.14) (2.59) (4.01) [-.127E-6>
THE/UG ; PHI/DA ; PSI/DP	- .000155 (0) (.0348) (.0644) (.0794) (.417) (.435) (1.58) (4.01) (5.75) [-.181E-6>
PSI/UG ; PHI/DA ; THE/DB	- .000517 (0) (.0310) (.0644) (.0699) (.383) (.541) (.588) (2.59) (5.75) [-.140E-6>
PHI/VG ; THE/DR ; PSI/DP	.000224 (0) (.00545) (.0699) (.0794) (-.370) (-.454) (1.00) (2.59) (4.01) [-.118E-7>
THE/VG ; PHI/DA ; PSI/DP	.000578 (0) (.00919) (.0644) (.0794) (.417) (.435) (.579) (4.01) (5.75) [-.657E-7>
PSI/VG ; PHI/DA ; THE/DB	.000976 (0) (.00752) (.0644) (.0699) (.541) (.543) (.588) (2.59) (5.75) [-.850E-7>
PHI/WG ; THE/DR ; PSI/DP	.000409 (0) (.0699) (.0794) (-.370) (1.00) (2.59) (4.01) [.959; .0291] [-.737E-8>
THE/WG ; PHI/DA ; PSI/DP	- .000715 (0) (.0182) (.0455) (.0644) (.0794) (.417) (.435) (4.01) (5.75) [-.126E-7>
PSI/WG ; PHI/DA ; THE/DR	- .000321 (0) (-.00663) (.0509) (.0644) (.0699) (-.541) (-.588) (2.59) (5.75) [-.231E-8>

TABLE IV-5 CONTINUED
AH-IG TRANSFER FUNCTION FACTORS

CASE 61 20KT SCAS ON

GUST NUMERATORS CONCLUDED:

PHI/PG ; THE/DB ; PSI/DP	.131 (.00824) (.0339) (.0699) (.0794) (.370) (.531) (1.00) (2.59) (4.01) <.415E-6>
THE/PG ; PHI/DA ; PSI/DP	.0744 (.00757) (.0325) (.0644) (.0794) (.417) (.435) (.524) (4.01) (5.75) <.204E-6>
PSI/PG ; PHI/DA ; THE/DB	-.0277 (.00737) (.0421) (.0644) (.0699) (.536) (.541) (.588) (2.59) (5.75) <-.983E-7>
PHI/OG ; THE/DB ; PSI/DP	-.0902 (.0102) (.0347) (.0699) (.0794) (.370) (.526) (1.00) (2.59) (4.01) <.360E-6>
THE/OG ; PHI/DA ; PSI/DP	-.0869 (.0116) (.0328) (.0644) (.0794) (.417) (.435) (.524) (4.01) (5.75) <-.369E-6>
PSI/OG ; PHI/DA ; THE/DB	.0195 (.0155) (.0477) (.0644) (.0699) (.539) (.541) (.588) (2.59) (5.75) <.158E-6>
PHI/RG ; THE/DB ; PSI/DP	.0226 (.0131) (.0353) (.0699) (.0794) (.370) (.561) (1.00) (2.59) (4.01) <.961E-7>
THE/RG ; PHI/DA ; PSI/DP	.00230 (.0544) (-.0745) (.0794) (.417) (.435) (4.01) (5.75) [.689; .0770] <-.217E-7>
PSI/RG ; PHI/DA ; THE/DB	-.0443 (.00676) (.0319) (.0644) (.0699) (.541) (.542) (.588) (2.59) (5.75) <-.110E-6>
XD/UG ; PHI/DA ; THE/DB	-.00143 (0) (.0644) (.0699) (.242) (2.59) (5.75) [-.530; .165] [.611; 2.21] <-.309E-5>
XD/UG ; PHI/DA ; PSI/DP	-.00787 (.0348) (.0644) (.0794) (.371) (.641) (2.37) (4.01) (5.75) [.332; .582] <-.584E-5>
XD/UG ; THE/DB ; PSI/DP	.00203 (.0699) (.0794) (.0980) (.249) (2.59) (4.01) [-.145; .106] [.773; 3.46] <.381E-6>
ZD/UG ; PHI/DA ; THE/DB	-.0184 (0) (0) (.0644) (.0699) (2.59) (5.75) [.531; .175] [.623; 2.26] <-.000193>
ZD/UG ; PHI/DA ; PSI/DP	-.0836 (0) (.0644) (.0794) (.211) (.805) (2.68) (4.01) (5.75) [.996; .0360] <-.613E-5>
ZD/UG ; THE/DB ; PSI/DP	-.0269 (0) (.0699) (.0794) (.133) (2.59) (4.01) [-.239; .128] [.772; 3.46] <.403E-4>
YD/VG ; PHI/DA ; THE/DB	-.00388 (0) (.00730) (.0644) (.0652) (.0699) (.518) (2.59) (5.75) [.614; 1.88] <-.226E-6>
YD/VG ; PHI/DA ; PSI/DP	-.0132 (.0644) (.0794) (.256) (.512) (.840) (2.67) (4.01) (5.75) [-.0965; .113] <-.584E-5>
YD/VG ; THE/DB ; PSI/DP	.00445 (.00544) (.0699) (.0794) (.522) (2.59) (4.01) [.459; .211] [.701; 3.43] <.381E-6>
XD/WG ; PHI/DA ; THE/DB	-.00167 (0) (0) (.0644) (.0699) (2.59) (5.75) [-.524; .168] [.613; 2.23] <-.158E-4>
XD/WG ; PHI/DA ; PSI/DP	-.0240 (0) (.0414) (.0644) (.0794) (.318) (.597) (-.919) (4.01) (5.75) <.204E-4>
XD/WG ; THE/DB ; PSI/DP	-.00241 (0) (.0699) (.0794) (.129) (2.59) (4.01) [-.235; .121] [.772; 3.46] <.314E-5>
ZD/WG ; PHI/DA ; THE/DB	-.0410 (0) (.00765) (.0644) (.0699) (2.59) (5.75) [.528; .170] [.619; 2.26] <-.309E-5>
ZD/WG ; PHI/DA ; PSI/DP	-.191 (.0345) (.0644) (.0794) (.243) (.779) (2.82) (4.01) (5.75) [-.0307; .119] <-.584E-5>
ZD/WG ; THE/DB ; PSI/DP	.060 (.00559) (.0699) (.0794) (.125) (2.59) (4.01) [-.224; .114] [.773; 3.46] <.380E-6>
XD/UG ; ZD/DC ; PHI/DA	-.119 (0) (.0644) (.751) (2.44) (5.75) [-.974; .251] [-.371; .304] [.618; 2.37] <-.265E-2>
XD/UG ; ZD/DC ; THE/DB	.0403 (0) (.0699) (2.59) [-.919; .0929] [.106; .174] [.599; 2.20] [.751; 3.35] <.104E-3>
XD/UG ; ZD/DC ; PSI/DP	.163 (.0794) (-.267) (.745) (2.71) (4.01) [-.0390; .209] [-.964; .229] [.743; 3.69] <-.256E-3>
YD/VG ; ZD/DC ; PHI/DA	-.288 (0) (.0644) (-.0718) (.193) (.817) (2.71) (5.75) [-.843; .128] [.608; 1.89] <.190E-3>
YD/VG ; ZD/DC ; THE/DB	.112 (0) (.0197) (.0699) (.0753) (2.59) [-.534; .299] [.656; 1.90] [-.572; 3.37] <.104E-3>
YD/VG ; ZD/DC ; PSI/DP	.365 (-.0766) (.0794) (.817) (2.64) (4.01) [-.956; .209] [-.414; .300] [.671; 3.40] <-.256E-3>
XD/UG ; PHI/DA ; THE/DB ; PSI/DP	.0010 (.0341) (.0644) (.0699) (.0794) (.244) (2.59) (4.01) (5.75) <.185E-6>
ZD/UG ; PHI/DA ; THE/DB ; PSI/DP	.0133 (0) (.0343) (.0644) (.0699) (.0794) (2.59) (4.01) (5.75) <.101E-4>
YD/VG ; PHI/DA ; THE/DB ; PSI/DP	.0021 (.00806) (.0644) (.0699) (.0794) (.518) (2.59) (4.01) (5.75) <.185E-6>
XD/WG ; PHI/DA ; THE/DB ; PSI/DP	.0012 (0) (.0349) (.0644) (.0699) (.0794) (2.59) (4.01) (5.75) <.920E-6>
ZD/WG ; PHI/DA ; THE/DB ; PSI/DP	.0309 (.00821) (.0343) (.0644) (.0699) (.0794) (2.59) (4.01) (5.75) <.185E-6>
XD/UG ; ZD/DC ; PHI/DA ; THE/DB	.0202 (0) (.0644) (.0699) (2.59) (5.75) [-.511; .162] [.595; 2.16] <.166E-3>
YD/VG ; ZD/DC ; PHI/DA ; THE/DB	.0448 (0) (.0183) (.0614) (.0644) (.0699) (2.59) (5.75) [-.607; 1.90] <.122E-2>
YD/VG ; ZD/DC ; PHI/DA ; PSI/DP	.163 (-.0400) (.0644) (.0794) (.144) (.171) (.817) (2.62) (4.01) (5.75) <-.03E-4>
XD/WG ; ZD/DC ; PHI/DA ; THE/DB	.0269 (0) (.0644) (.0699) (2.59) (5.75) [-.509; .162] [.593; 2.16] <.220E-3>
XD/UG ; ZD/DC ; PHI/DA ; THE/DB ; PSI/DP	-.0144 (.0350) (.0644) (.0699) (.0794) (2.59) (4.01) (5.75) <-.107E-4>
YD/VG ; ZD/DC ; PHI/DA ; THE/DB ; PSI/DP	-.0252 (.0200) (.0644) (.0699) (.0794) (2.59) (4.01) (5.75) <-.107E-4>
XD/WG ; ZD/DC ; PHI/DA ; THE/DB ; PSI/DP	-.0189 (.0349) (.0644) (.0699) (.0794) (2.59) (4.01) (5.75) <-.141E-4>

TABLE IV-5 CONTINUED
AH-IG TRANSFER FUNCTION FACTORS

CASE 62 40 KT SCAS OFF

DENOMINATOR: (0) (.115) (1.34) [-.166;.322] [.814;.717] [-.279;.967] <.00774>

CONTROL NUMERATORS:

PHI/DA .493 (0) [-.268;.349] [.915;.676] [.399;.981] <.0264>
THE/DB -.159 (0) (.00417) (.116) (.750) (1.34) [-.283;.965] <-.715E-4>
PSI/DP -.785 (1.39) [.123;.103] [-.191;.354] [.798;.732] <-.000772>

PHI/DB .0317 (0) (-.130) (.136) (1.38) (3.60) [.308;.920] <-.00236>
THE/DA .0922 (0) (-.00197) (.131) (.755) [-.298;1.03] <-.193E-4>

PHI/DA ; THE/DB -.0782 (0) (.00450) (.752) [.416;.970] <-.000249>
PHI/DA ; PSI/DP -.396 (.0536) [-.232;.330] [-.872;.668] <-.00103>
THE/DB ; PSI/DP .124 (.00398) (.740) (1.35) [.149;.143] <-.101E-4>

PHI/DB ; PSI/DP -.0342 (.0557) (.0982) (-.132) [.897;1.75] <.757E-4>
PHI/DP ; THE/DB -.0507 (0) (.00394) (-.121) (.686) (.922) <.152E-4>
PHI/DC ; THE/DB -.0150 (0) (.00342) (.978) [.282;1.61] <-.000129>

THE/DA ; PSI/DP -.0728 (.00302) (.753) [.0262;.412] <-.281E-4>
THE/DP ; PHI/DA .00329 (0) (.00321) (.772) [-.170;2.77] <.627E-4>
THE/DC ; PHI/DA .0174 (0) (.0338) (1.85) [.500;.698] <.000529>

PSI/DA ; THE/DB -.00463 (.00454) (.756) (1.17) (-1.32) (-4.69) <-.000115>
PSI/DB ; PHI/DA .0135 (.0504) (.362) (-1.42) [-.221;1.10] <-.000428>
XD/DB ; PHI/DA .621 (0) (.713) [.416;.971] [.0192;2.06] <1.77>

YD/DA ; THE/DB -.135 (.00454) (.752) [.365;.950] [.0207;4.32] <-.00775>
ZD/DB ; PHI/DA .913 (0) (-.0837) [.424;.981] [.0738;2.06] <-.312>
XD/DC ; PHI/DA -.0622 (0) (1.65) [-.501;.735] [-.146;3.05] <-.517>

YD/DP ; THE/DB -.231 (.00399) (-.271) (.641) (.864) [.109;2.22] <.000683>
ZD/DC ; PHI/DA -6.56 (0) (-.390) [.0747;.395] [.329;.950] <-.359>

PHI/DA ; THE/DB ; PSI/DP .0627 (0) (.0531) (.746) <.00248>
PHI/DC ; THE/DB ; PSI/DP .0306 (0) (.0525) (.978) <.00157>
THE/DC ; PHI/DA ; PSI/DP -.0152 (.0172) (.0572) (1.54) <-.230E-4>

PSI/DC ; PHI/DA ; THE/DB -.0287 (0) (.0593) (.989) <-.00168>
XD/DB ; PHI/DA ; PSI/DP -.498 (.0532) (.709) [.0195;2.06] <-.0796>
YD/DA ; THE/DB ; PSI/DP .112 (.00433) (.746) [-.0121;4.24] <.00653>

ZD/DC ; PHI/DA ; THE/DB 1.01 (0) (.0110) [.409;.932] <.00966>
ZD/DC ; PHI/DA ; PSI/DP 5.29 (.0512) (.163) [.129;.530] <.0124>
XD/DC ; PHI/DA ; THE/DB -.0120 (0) (2.48) [.384;1.01] <-.0307>

XD/DC ; PHI/DA ; PSI/DP .0644 (.0562) (1.34) [-.175;2.95] <.0424>
YD/DP ; PHI/DA ; THE/DB -.0709 (.00434) (.742) (1.73) (-1.84) <.000728>
ZD/DB ; PHI/DA ; PSI/DP -.732 (.0533) (-.0773) [.0697;2.08] <.0130>

ZD/DC ; PHI/DA ; THE/DB ; PSI/DP -.810 (.00960) (.0538) <-.000418>
XD/DC ; PHI/DA ; THE/DB ; PSI/DP .00884 (.0529) (2.83) <.00133>

TABLE IV-5 CONTINUED
AH-IG TRANSFER FUNCTION FACTORS

CASE 62 40KT SCAS ON

DENOMINATOR: (0) (.256) (.655) (.959) (2.73) [-.523; .0714] [-.0381; .156] [.557; .216] [.620; 2.44] [.773; 3.37] <.000171>

CONTROL NUMERATORS:

PHI/DA .493 (0) (.0644) (.257) (.656) (.954) (2.76) (5.75) [-.0922; .152] [.604; .233] [.617; 2.39] <.000575>
 THE/DB - .159 (0) (.00415) (.0649) (.746) (2.59) [-.575; .0754] [-.526; .220] [.621; 2.46] [.772; 3.34] <-.166E-5>
 PSI/DP - .785 (.0794) (.117) (.256) (.655) (.956) (2.72) (4.01) [-.0673; .0675] [-.0819; .154] [.796; 3.47] <-.165E-4>

PHI/DB .0317 (0) (.0699) (-.125) (.126) (.371) (1.11) (1.54) (2.59) (3.76) [.505; .257] [.700; 1.90] <-.513E-4>
 THE/DA .101 (0) (0) (.0644) (.0765) (.753) (5.75) [-.000; .427] [.206; .468] [.600; 2.35] <.000477>

PHI/DA ; THE/DB - .0782 (0) (.00450) (.0644) (.0699) (.746) (2.59) (5.75) [-.582; .232] [.619; 2.40] <-.546E-5>
 PHI/DA ; PSI/DP - .396 (.0536) (.0644) (.0794) (.256) (.656) (.956) (2.70) (4.01) (5.75) [-.0562; .143] <-.220E-4>
 THE/DB ; PSI/DP .124 (.00398) (.0699) (.0794) (.115) (.746) (2.59) (4.01) [-.111; .0856] [.790; 3.47] <.216E-6>

PHI/DB ; PSI/DP - .0342 (.0557) (.0699) (.0794) (.0992) (-.132) (.370) (1.00) (2.59) (4.01) [.897; 1.75] <.162E-5>
 PHI/DP ; THE/DB - .0507 (0) (.00394) (.0644) (.0794) (-.0966) (.216) (.743) (2.59) (4.01) [.820; 1.35] <.325E-6>
 PHI/DC ; THE/DB - .0150 (0) (.00342) (.0699) (.363) (.985) (1.03) (2.59) [-.581; .257] [.661; 3.54] <-.283E-5>

THE/DA ; PSI/DP - .0728 (.00302) (.0644) (.0794) (.417) (.435) (.753) (4.01) (5.75) [.0262; .412] <-.599E-6>
 THE/DP ; PHI/DA - .00329 (0) (.00319) (.0644) (.0794) (.345) (.540) (.771) (4.01) (5.75) [-.922; 2.70] <.129E-5>
 THE/DC ; PHI/DA - .0174 (0) (.0335) (.0644) (1.68) (5.75) [-.565; .176] [.000; .427] [.744; 2.39] <.116E-4>

PSI/DA ; THE/DB - .00463 (.00454) (.0644) (.0699) (.541) (.588) (.756) (1.17) (-1.32) (2.59) (-4.69) (5.75) <-.245E-5>
 PSI/DB ; PHI/DA - .0135 (.0504) (.0644) (.0699) (.643) (-1.27) (2.59) (5.75) [.990; .413] [-.215; 1.20] <-.914E-5>
 XD/DB ; PHI/DA .621 (0) (.0644) (.0699) (.709) (2.59) (5.75) [-.583; .232] [.0196; 2.06] [.618; 2.40] <.0389>

YD/DA ; THE/DB - .135 (.00454) (.0644) (.0699) (.746) (2.59) (5.75) [-.490; .225] [.600; 2.43] [.0262; 4.26] <-.000165>
 ZD/DB ; PHI/DA .313 (0) (.0644) (.0699) (-.0828) (2.59) (5.75) [-.590; .233] [-.6672; 2.07] [.623; 2.41] <-.00683>
 XD/DC ; PHI/DA - .0622 (0) (.0644) (.329) (.580) (1.79) (5.75) [-.570; .186] [.696; 2.47] [-.697; 2.67] <-.0118>

YD/DP ; THE/DB - .231 (.00399) (.0699) (.0794) (-.706) (.741) (1.34) (2.59) (4.01) [.172; .186] [.512; 3.37] <.146E-4>
 ZD/DC ; PHI/DA - 6.56 (0) (.0644) (.226) (.826) (2.68) (5.75) [-.102; .137] [.644; .248] [-.614; 2.36] <-.00776>

PHI/DA ; THE/DB ; PSI/DP .0627 (.00434) (.0531) (.0644) (.0699) (.0794) (.746) (2.59) (4.01) (5.75) <.230E-6>
 PHI/DC ; THE/DB ; PSI/DP .0306 (.00354) (.0525) (.0699) (.0794) (.370) (.978) (1.00) (2.59) (4.01) <.119E-6>
 THE/DC ; PHI/DA ; PSI/DP - .0152 (.0172) (.0572) (.0644) (.0794) (.417) (.435) (1.54) (4.01) (5.75) <-.490E-6>

PSI/DC ; PHI/DA ; THE/DB - .0287 (0) (.0593) (.0644) (.0699) (.541) (.588) (.789) (2.59) (5.75) <-.358E-4>
 XD/DB ; PHI/DA ; PSI/DP - .498 (.0532) (.0644) (.0699) (.0794) (.709) (2.59) (4.01) (5.75) [.0195; 2.06] <-.00170>
 YD/DA ; THE/DB ; PSI/DP .112 (.00433) (.0644) (.0699) (.0794) (.746) (2.59) (4.01) (5.75) [-.0121; 4.24] <.000139>

ZD/DC ; PHI/DA ; THE/DB 1.01 (0) (.0110) (.0644) (.0699) (2.59) (5.75) [-.576; .223] [.615; 2.39] <.000212>
 ZD/DC ; PHI/DA ; PSI/DP 5.29 (.0515) (.0644) (.0794) (.213) (.827) (2.60) (4.01) (5.75) [.382; .134] <.000265>
 XD/DC ; PHI/DA ; THE/DB - .0120 (0) (.0644) (.0699) (2.55) (2.59) (5.75) [-.584; .236] [.567; 2.42] <-.000672>

XD/DC ; PHI/DA ; PSI/DP .0644 (.0561) (.0644) (.0794) (.330) (.580) (1.64) (4.01) (5.75) [-.715; 2.60] <.000904>
 YD/DP ; PHI/DA ; THE/DB - .0709 (.00434) (.0644) (.0699) (.0794) (.742) (1.73) (-1.84) (2.59) (4.01) (5.75) <.155E-4>
 ZD/DB ; PHI/DA ; PSI/DP - .732 (.0533) (.0644) (.0699) (-.0773) (.0794) (2.59) (4.01) (5.75) [.0697; 2.08] <.000277>

ZD/DC ; PHI/DA ; THE/DB ; PSI/DP - .810 (.00960) (.0538) (.0644) (.0699) (.0794) (2.59) (4.01) (5.75) <-.892E-5>
 XD/DC ; PHI/DA ; THE/DB ; PSI/DP .00884 (.0529) (.0644) (.0699) (.0794) (2.59) (2.83) (4.01) (5.75) <.283E-4>

TABLE IV-5 CONTINUED
 AH-IG TRANSFER FUNCTION FACTORS

CASE 63 60KT SCAS OFF

DENOMINATOR: (0) (.0725) (1.44) [-.0600; .264] [.705; .820] [.337; 1.23] <.00739>
 S R P SP D

CONTROL NUMERATORS:

PHI/DA .486 (0) [-.152; .319] [.838; .789] [.389; 1.25] <.0480>
 THE/DB -.157 (0) (.00426) (.0697) (.922) (1.34) [.334; 1.23] <-.869E-4>
 PSI/DP -.944 (-.135) (.221) (1.48) [-.0724; .299] [.690; .828] <.00256>

PHI/DB .0213 (0) (.269) (-.315) [.286; 1.21] [.975; 3.11] <-.0256>
 PHI/DP .378 (0) (.360) (.951) [-.355; .330] [.619; .821] <.00951>
 PHI/DC .0659 (0) (.692) (1.30) [-.334; .441] [.265; 1.83] <.0387>

THE/DA .0853 (0) (-.00905) (.0608) (.895) [.359; 1.24] <-.649E-4>
 THE/DP .0545 (0) (-.00824) (.0676) (.985) [.487; .967] <-.279E-4>
 THE/DC .0322 (0) (.00935) (.0655) (1.40) (2.83) [.309; 1.27] <.000126>

PSI/DA .0269 (.807) (-1.46) (-4.34) [-.118; .311] [.769; 1.05] <.0146>
 PSI/DB -.0361 (.272) (-.368) (1.36) [.129; .952] [-.502; 1.33] <-.00787>
 PSI/DC -.294 (1.41) [-.488; .354] [.185; .535] [.942; .898] <.0120>

XD/DB 1.19 (0) (.0673) (.872) (1.34) [.334; 1.23] [.0204; 2.11] <.633>
 YD/DA .842 [-.145; .322] [.817; .780] [.341; 1.22] [.0237; 4.33] <1.48>
 ZD/DC -15.0 (0) (1.45) [.934; .0697] [.100; .813] [.354; 1.21] <-.102>

XD/DC -.0864 (0) (.0608) (1.39) (3.14) [.320; 1.27] [-.0174; 3.29] <-.402>
 YD/DP 1.74 [-.587; .499] [.305; .687] [.878; .693] [.363; 1.63] <.259>
 ZD/DB 3.00 (0) (-.0111) (.0692) (1.36) [.337; 1.24] [.0975; 2.18] <-.0229>

PHI/DA ;THE/DB -.0763 (0) (.00727) (.909) [.398; 1.25] <-.000790>
 PHI/DA ;PSI/DP -.469 (.0765) [-.137; .314] [.813; .782] <-.00216>
 THE/DB ;PSI/DP .148 (.0163) (-.104) (.197) (.907) (1.33) <-.599E-4>

PHI/DB ;PSI/DP -.0338 (.0760) (.270) (-.327) [.638; 2.36] <.00126>
 PHI/DP ;THE/DB -.0594 (0) (.0146) (.981) [.823; .495] <-.000209>
 PHI/DC ;THE/DB -.0110 (0) (0) (1.47) [.328; 1.92] <-.0598>

THE/DA ;PSI/DP -.0811 (-.00778) (.893) [.119; .241] <.327E-4>
 THE/DP ;PHI/DA .00286 (0) (-.00764) (.994) [-.557; 2.12] <-.980E-4>
 THE/DC ;PHI/DA .0158 (0) (.0224) (2.35) [.453; 1.18] <.00116>

PSI/DA ;THE/DB -.00412 (.00730) (.891) (1.46) (-1.59) (-3.85) <-.000241>
 PSI/DB ;PHI/DA .0170 (.0707) (.312) (-.540) [-.289; 1.67] <-.000564>
 PSI/DC ;THE/DB -.0472 (0) [-.124; .459] [.999; 1.37] <-.0187>

PSI/DC ;PHI/DA .141 (.0817) [-.235; .364] [.961; .963] <.00142>
 XD/DB ;PHI/DA .580 (0) (.854) [.397; 1.25] [.0216; 2.12] <3.49>
 XD/DB ;PSI/DP -1.12 (-.0991) (-.199) (.867) (1.32) [.0200; 2.11] <.113>

YD/DA ;THE/DB -.132 (.00731) (.910) [.335; 1.21] [.0241; 4.34] <-.0244>
 YD/DA ;PSI/DP -.842 [-.137; .314] [.808; .781] [-.0118; 4.26] <-.918>
 ZD/DC ;PHI/DA -7.31 (0) (.156) [.193; .684] [.380; 1.19] <-.758>

ZD/DC ;THE/DB 2.26 (0) (.00522) (.0704) (1.34) [.329; 1.19] <.00159>
 ZD/DC ;PSI/DP 14.2 (-.0631) (1.50) [.651; .154] [-.124; .818] <-.0214>
 XD/DC ;PHI/DA -.0429 (0) (2.26) [.459; 1.22] [-.0834; 3.39] <-1.67>

XD/DC ;THE/DB -.0248 (0) (.0433) (1.33) (2.42) [.351; 1.33] <-.00608>
 XD/DC ;PSI/DP .0951 (1.37) (3.77) [.553; .0695] [.0362; 3.04] <.0220>
 YD/DP ;PHI/DA .527 (2.56) (-2.71) [-.135; .313] [.806; .781] <-.219>

YD/DP ;THE/DB -.273 (.0169) (.959) [-.197; .727] [.387; 1.61] <-.00606>
 ZD/DB ;PHI/DA 1.46 (0) (-.00789) [.405; 1.27] [.0905; 2.17] <-.0868>
 ZD/DB ;PSI/DP -2.83 (.205) (1.36) [-.921; .0672] [.0932; 2.19] <-.0171>

PHI/DA ;THE/DB ;PSI/DP .0735 (.00683) (.0762) (.899) <.344E-4>
 PHI/DC ;THE/DB ;PSI/DP .0283 (0) (.0768) (1.44) <.00312>
 THE/DC ;PHI/DA ;PSI/DP -.0161 (.0181) (.0775) (2.19) <-.493E-4>

TABLE IV-5 CONTINUED
AH-IG TRANSFER FUNCTION FACTORS

CASE 63 60KT SCAS OFF

CONTROL NUMERATORS CONCLUDED:

PSI/DC ; PHI/DA ; THE/DB -0.0227 (.00376) (.0839) (1.36) <- .970E-5>

 XD/DB ; PHI/DA ; PSI/DP -0.558 (.0763) (.850) [.0211; 2.12] <- .162>
 YD/DA ; THE/DB ; PSI/DP .132 (.00680) (.900) [-.00857; 4.25] <.0146>
 ZD/DC ; PHI/DA ; THE/DB 1.10 (0) (.00895) [.395; 1.22] <.0146>

 ZD/DC ; THE/DB ; PSI/DP -2.13 (-.0615) (1.34) [-.943; .0791] <.00110>
 ZD/DC ; PHI/DA ; PSI/DP 7.08 (.0762) (.141) [-.149; .692] <.0365>
 XD/DC ; PHI/DA ; THE/DB -0.0121 (0) (2.50) [.382; 1.37] <- .0568>

 XD/DC ; PHI/DA ; PSI/DP .0495 (.0772) (1.99) [-.122; 3.39] <.0875>
 XD/DC ; THE/DB ; PSI/DP .0226 (-.195) (.309) (1.31) (2.51) <- .00446>
 YD/DP ; PHI/DA ; THE/DB -0.0827 (.00682) (.896) (2.55) (-2.71) <.00348>

 ZD/DB ; PHI/DA ; PSI/DP -1.40 (-.00582) (.0764) [.0889; 2.18] <.00298>

 ZD/DC ; PHI/DA ; THE/DB ; PSI/DP -1.06 (.00796) (.0768) <- .000648>
 XD/DC ; PHI/DA ; THE/DB ; PSI/DP .0114 (.0752) (2.69) <.00231>

GUST NUMERATORS:

PHI/UG .00281 (0) (0) (0) [.593; 1.03] [.458; 1.55] <.00717>
 THE/UG -0.00201 (0) (0) (.0729) [-.976; 1.03] [.350; 1.22] <- .000230>
 PSI/UG .00452 (0) (0) (1.30) [-.268; .667] [.592; .919] <.00220>

 PHI/VG .00520 (0) (0) (-.889) [-.0837; .280] [.734; .796] <.000230>
 THE/VG -0.000139 (0) (0) (.0342) (-2.40) [.898; .761] <.660E-5>
 PSI/VG -0.0143 (0) (0) (1.48) [-.0456; .265] [.707; .813] <- .000983>

 PHI/WG .00280 (0) (0) (.551) [-.455; .537] [.198; 1.65] <.00121>
 THE/WG .00300 (0) (0) (-.0118) (.0664) (1.67) [.316; 1.25] <.610E-5>
 PSI/WG .00904 (0) (-.648) (1.25) [-.558; .379] [.203; .600] <.000376>

 PHI/PG 1.27 (0) [-.0847; .260] [.775; .865] [.392; 1.27] <.103>
 THE/PG -.180 (0) (.0358) (.909) [-.0762; .157] [.361; 1.21] <- .000212>
 PSI/PG .319 (1.06) [-.0830; .261] [.710; .930] [-.528; 1.26] <.0313>

 PHI/QG .681 (0) (.463) (.930) [-.503; .492] [.391; 1.23] <.108>
 THE/QG .321 (0) (.00413) (.0674) (.845) (1.73) [.343; 1.23] <.000198>
 PSI/QG -.296 (.399) (-.504) (1.72) [-.209; .443] [.611; 1.27] <.0328>

 PHI/RG -.0312 (0) (3.38) (-4.10) [-.111; .277] [.770; .837] <.0233>
 THE/RG -.0201 (0) (0) (-.0367) (-.383) (.974) [.510; 1.58] <.000691>
 PSI/RG .915 (1.40) [-.183; .266] [.0714; .348] [.734; .820] <.00739>

 XD/UG .0228 (0) (.0733) [.988; .983] [.346; 1.21] [.0600; 1.77] <.00739>
 ZD/UG .0740 (0) (0) (.0731) (1.11) [-.313; 1.19] [.228; 1.65] <.0233>
 YD/VG .102 (0) (.928) [-.0913; .278] [.742; .784] [.407; 1.28] <.00739>

 XD/WG -.00344 (0) (0) (.0627) (1.86) [.321; 1.25] [.0182; 5.00] <- .0156>
 ZD/WG .841 (0) (-.0728) (.597) (1.27) [-.242; .322] [.342; 1.24] <.00739>

 PHI/UG ; THE/DB -.000398 (0) (0) (.842) [.350; 1.54] <- .000795>
 PHI/UG ; PSI/DP -.00436 (0) (0) (-.0772) [-.636; 1.02] <- .000352>
 THE/UG ; PHI/DA -.000969 (0) (0) (.960) [.378; 1.27] <- .00149>

 THE/UG ; PSI/DP .00188 (0) (-.152) (.297) [.967; .968] <- .796E-4>
 PSI/UG ; PHI/DA .00212 (0) (0) (.0888) [.484; .879] <.000146>
 PSI/UG ; THE/DB -.000637 (0) (-.828) (1.38) [-.211; .581] <- .000245>

 PHI/VG ; THE/DB -.000813 (0) (0) (.00440) [-.977; .869] <- .270E-5>
 PHI/VG ; PSI/DP .000501 (0) (.558) (1.25) [-.389; .478] <.797E-4>
 THE/VG ; PHI/DA -.543E-4 (0) (0) (-.0115) (.706) (4.57) <.202E-5>

 THE/VG ; PSI/DP .000187 (0) (0) (-.00301) (1.30) (1.95) <- .143E-5>
 PSI/VG ; PHI/DA -.00710 (0) [-.148; .320] [.827; .790] <- .000455>
 PSI/VG ; THE/DB .00225 (0) (0) (.00658) (.942) (1.33) <.186E-4>

TABLE IV-5 CONTINUED
AH-IG TRANSFER FUNCTION FACTORS

CASE 63 60KT SCAS OFF

GUST NUMERATOR CONTINUED:

PHI/WG ;THE/DB	- .000503 (0) (0) (-.00438) [.311;1.76]<.681E-5>
PHI/WG ;PSI/DP	- .00606 (0) (.0780) (.543) [-.467;.497]<-.634E-4>
THE/WG ;PHI/DA	.00147 (0) (0) (.0226) [.434;1.23]<.503E-4>
THE/WG ;PSI/DP	- .00287 (0) (-.0673) (1.79) [.790;.101]<.353E-5>
PSI/WG ;PHI/DA	.00432 (0) (.0912) (.695) [-.279;.401]<.440E-4>
PSI/WG ;THE/DB	- .00153 (0) (-.00423) (1.37) [-.114;.483]<.206E-5>
PHI/PG ;THE/DB	- .195 (0) (.00658) (.917) [.388;1.29]<-.00195>
PHI/PG ;PSI/DP	- 1.32 (-.0768) [-.0788;.252] [.755;.849]<-.00464>
THE/PG ;PHI/DA	- .0846 (0) (.00403) (.882) [-.383;1.26]<-.000476>
THE/PG ;PSI/DP	.169 (-.00295) (-.414) (.914) [.468;.487]<.448E-4>
PSI/PG ;PHI/DA	.121 (0) (-.0861) (.161) [.445;1.00]<-.00168>
PSI/PG ;THE/DB	- .0435 (.00660) (-.912) (1.43) [-.531;1.26]<-.000595>
PHI/QG ;THE/DB	- .114 (0) (.00441) (.835) [.435;1.18]<-.000580>
PHI/QG ;PSI/DP	- .531 (.0760) (.474) (.923) [-.507;.526]<-.00489>
THE/QG ;PHI/DA	.158 (0) (.0106) (.849) [.387;1.25]<.00223>
THE/QG ;PSI/DP	- .301 (-.0662) (-.824) (1.73) [.938;.0824]<.000193>
PSI/QG ;PHI/DA	- .162 (-.0428) (-.156) (.176) [.403;1.11]<.000234>
PSI/QG ;THE/DB	.0349 (.00442) (-.570) (.696) [.999;1.69]<-.000174>
PHI/RG ;THE/DB	.00532 (0) (.00441) (.939) (3.37) (-3.69)<-.000274>
PHI/RG ;PSI/DP	- .316 (-.0759) [-.135;.300] [.810;.817]<-.00144>
THE/RG ;PHI/DA	- .00988 (0) (-.0115) (.830) [-.0439;1.47]<.000204>
THE/RG ;PSI/DP	.0154 (-.00890) (.979) (-2.76) [.156;.275]<.279E-4>
PSI/RG ;PHI/DA	.446 (-.0742) [-.136;.311] [.807;.793]<.00201>
PSI/RG ;THE/DB	- .143 (.00441) (.931) (1.35) [-.0374;.331]<-.869E-4>
XD/UG ;PHI/DA	.0111 (0) (.873) [.375;1.27] [.0470;1.76]<.0480>
XD/UG ;THE/DB	- .00119 (0) (.0441) (.795) (1.28) [.333;1.28]<-.869E-4>
XD/UG ;PSI/DP	- .0213 (-.153) (.297) [.978;.931] [.0631;1.75]<.00256>
ZD/UG ;PHI/DA	.0358 (0) (0) [.338;1.28] [.188;1.60]<.151>
ZD/UG ;THE/DB	- .00560 (0) (0) (-.0671) (1.48) [.408;1.33]<-.000985>
ZD/UG ;PSI/DP	- .0694 (0) (-.158) (.282) (1.03) [.184;1.59]<.00806>
YD/VG ;PHI/DA	.0454 (0) (.794) [-.127;.311] [.791;.758]<.00201>
YD/VG ;THE/DB	- .0161 (0) (.00440) [.974;.886] [.417;1.25]<-.869E-4>
YD/VG ;PSI/DP	- .0717 (-.249) (1.53) [.0770;.397] [.814;.772]<.00256>
XD/WG ;PHI/DA	- .00171 (0) (0) [.428;1.26] [-.0700;5.14]<-.0717>
XD/WG ;THE/DB	- .00304 (0) (0) (.0532) (1.30) [.330;1.27]<-.000339>
XD/WG ;PSI/DP	.00367 (0) (-.0203) (.0996) (2.08) [.0890;4.65]<-.000335>
ZD/WG ;PHI/DA	- .0409 (0) (0) (.574) [-.310;.361] [.407;1.25]<-.00480>
ZD/WG ;THE/DB	- .141 (0) (.00426) (-.0697) (1.36) [-.345;1.23]<-.869E-4>
ZD/WG ;PSI/DP	- .793 (-.144) (.251) (.587) (1.28) [-.242;.345]<.00256>
XD/UG ; ZD/DC	- .336 (0) (.0701) (1.02) [.346;1.16] [.0745;1.78]<-.102>
YD/VG ; ZD/DC	- 1.53 (0) (.0793) (-.916) [.140;.737] [.394;1.30]<-.102>
PHI/UG ;THE/DB ;PSI/DP	.000616 (0) (.0760) (.838) <.393E-4>
THE/UG ;PHI/DA ;PSI/DP	.000922 (0) (.0764) (.954) <.672E-4>
PSI/UG ;PHI/DA ;THE/DB	- .000299 (0) (.0719) (.815) <-.175E-4>
PHI/VG ;THE/DB ;PSI/DP	- .853E-4 (0) (.0168) (1.30) <-.186E-5>
THE/VG ;PHI/DA ;PSI/DP	.941E-4 (0) (-.00791) (1.37) <-.102E-5>
PSI/VG ;PHI/DA ;THE/DB	.00112 (0) (.00730) (.920) <.750E-5>
PHI/WG ;THE/DB ;PSI/DP	.00105 (0) (-.00321) (.0776) <-.262E-6>
THE/WG ;PHI/DA ;PSI/DP	- .00144 (0) (.0192) (-.0785) <-.217E-5>
PSI/WG ;PHI/DA ;THE/DB	- .000729 (0) (.00185) (.0983) <-.133E-6>

TABLE IV-5 CONTINUED
AH-IG TRANSFER FUNCTION FACTORS

CASE 63 60KT SCAS OFF

GUST NUMERATORS CONCLUDED:

PHI/PG ; THE/DB ; PSI/DP	.200	(.00620)	(.0763)	(.910)	<.863E-4>
THE/PG ; PHI/DA ; PSI/DP	.0809	(.00403)	(.0759)	(.865)	<.214E-4>
PSI/PG ; PHI/DA ; THE/DB	-.0160	(-.00406)	(-.0867)	(.987)	<-.557E-5>
PHI/QG ; THE/DB ; PSI/DP	.0941	(.00332)	(.0760)	(.816)	<.193E-4>
THE/QG ; PHI/DA ; PSI/DP	-.151	(-.0105)	(-.0760)	(.829)	<-.000100>
PSI/QG ; PHI/DA ; THE/DB	.0200	(.0114)	(.0841)	(1.17)	<.224E-4>
PHI/RG ; THE/DB ; PSI/DP	.0490	(.00568)	(.0759)	(.946)	<.200E-4>
THE/RG ; PHI/DA ; PSI/DP	.00691	(-.0192)	(-.0819)	(.471)	<-.511E-5>
PSI/RG ; PHI/DA ; THE/DB	-.0696	(.00645)	(.0740)	(.921)	<-.306E-4>
XD/UG ; PHI/DA ; THE/DB	-.000581	(0)	(.808)	[.375; 1.30]	<-.000790>
XD/UG ; PHI/DA ; PSI/DP	-.0106	(.0764)	(.871)	[.0427; 1.76]	<-.00216>
XD/UG ; THE/DB ; PSI/DP	.00111	(-.179)	(.310)	(.791)	(1.23) <-.599E-4>
ZD/UG ; PHI/DA ; THE/DB	-.00272	(0)	(0)	[.449; 1.38]	<-.00518>
ZD/UG ; PHI/DA ; PSI/DP	-.0342	(0)	(.0765)	[.111; 1.61]	<-.00681>
ZD/UG ; THE/DB ; PSI/DP	.00526	(0)	(-.234)	(.386)	(1.52) <-.000721>
YD/VG ; PHI/DA ; THE/DB	-.00712	(0)	(.00644)	[.993; .816]	<-.306E-4>
YD/VG ; PHI/DA ; PSI/DP	-.0361	(-.136;	.313]	[.808; .781]	<-.00216>
YD/VG ; THE/DB ; PSI/DP	.0112	(.0162)	(-.216)	(1.12)	(1.36) <-.598E-4>
XD/WG ; PHI/DA ; THE/DB	-.00148	(0)	(0)	[.376; 1.29]	<-.00248>
XD/WG ; PHI/DA ; PSI/DP	.00190	(0)	(.0779)	(-.102; 4.94]	<.00361>
XD/WG ; THE/DB ; PSI/DP	.00284	(0)	(-.154)	(.270)	(1.26) <-.000149>
ZD/WG ; PHI/DA ; THE/DB	-.0686	(0)	(.00728)	[.408; 1.26]	<-.000790>
ZD/WG ; PHI/DA ; PSI/DP	-.394	(.0765)	(.562)	(-.310; .358]	<-.00216>
ZD/WG ; THE/DB ; PSI/DP	.133	(.0164)	(-.106)	(.190)	(1.36) <-.599E-4>
XD/UG ; ZD/DC ; PHI/DA	-.163	(0)	[.361; 1.22]	[.0603; 1.76]	<-.758>
XD/UG ; ZD/DC ; THE/DB	.0180	(0)	(.0440)	(1.25)	[.326; 1.27] <.00159>
XD/UG ; ZD/DC ; PSI/DP	.314	(-.112)	(.219)	(.913)	[.0786; 1.75] <-.0214>
YD/VG ; ZD/DC ; PHI/DA	-.677	(0)	(.109)	(.797)	[.106; .713] <-.0300>
YD/VG ; ZD/DC ; THE/DB	.230	(0)	(.00544)	(.770)	[.411; 1.28] <.00159>
YD/VG ; ZD/DC ; PSI/DP	1.09	(-.0866)	(.227)	(1.51)	[.0727; .813] <-.0214>
XD/UG ; PHI/DA ; THE/DB ; PSI/DP	.000556	(.0766)	(.808)	<.344E-4>	
ZD/UG ; PHI/DA ; THE/DB ; PSI/DP	.00260	(0)	(.0772)	<.000201>	
YD/VG ; PHI/DA ; THE/DB ; PSI/DP	.00565	(.00682)	(.893)	<.344E-4>	
XD/WG ; PHI/DA ; THE/DB ; PSI/DP	.00142	(0)	(.0746)	<.000106>	
ZD/WG ; PHI/DA ; THE/DB ; PSI/DP	.0660	(.00683)	(.0763)	<.344E-4>	
XD/UG ; ZD/DC ; PHI/DA ; THE/DB	.00880	(0)	[.365; 1.29]	<.0146>	
YD/VG ; ZD/DC ; PHI/DA ; THE/DB	.102	(0)	(.00775)	(.694)	<.000547>
YD/VG ; ZD/DC ; PHI/DA ; PSI/DP	.544	(.139)	[.149; .694]	<.0365>	
XD/WG ; ZD/DC ; PHI/DA ; THE/DB	.0322	(0)	[.348; 1.33]	<.0568>	
XD/UG ; ZD/DC ; PHI/DA ; THE/DB ; PSI/DP	-.00842	(.0770)	<-.000648>		
YD/VG ; ZD/DC ; PHI/DA ; THE/DB ; PSI/DP	-.0814	(.00796)	<-.000648>		
XD/WG ; ZD/DC ; PHI/DA ; THE/DB ; PSI/DP	-.0306	(.0752)	<-.00231>		

TABLE IV-5 CONTINUED
AH-1G TRANSFER FUNCTION FACTORS

CASE 63 60KT SCAS ON

DENOMINATOR: (0) (-.259) (.675) (1.20) (2.62) [-.463; .0369] [.0316; .146] [.638; .264] [-.626; 2.72] [-.776; 1.35] <-.923E-4>

CONTROL NUMERATORS:

PHI/DA .486 (0) (.0644) (.259) (.675) (1.20) (2.61) (5.75) [-.0384; .144] [.640; .268] [.625; 2.66] <.00105>
 THE/DB -.157 (0) (-.00272) (-.0699) (-.900) (2.59) [-.564; .0508] [.631; .266] [-.624; 2.75] [.779; 3.32] <-.106E-5>
 PSI/DP -.944 (.0794) (-.0825) (-.259) (.675) (1.20) (2.61) (4.07) [-.818; .124] [-.0262; .149] [.795; 3.44] <.546E-4>

PHI/DB .0213 (0) (.0699) (.266) (-.318) (.370) (1.04) (2.59) [-.630; .272] [-.522; 2.00] [.995; 3.90] <-.000563>
 PHI/DP .378 (0) (-.0794) (-.259) (.675) (1.20) (2.63) (4.01) [-.179; .162] [.779; .232] [.760; 1.40] <.000198>
 PHI/DC .0659 (0) (.259) (-.364) (.746) (1.04) (1.64) (2.62) [-.0672; .183] [-.623; .275] [.700; 4.03] <.000853>

THE/DA .0862 (0) (-.00271) (-.0644) (.0715) (-.893) (5.75) [-.365; .351] [.000; .428] [.614; 2.63] <-.861E-6>
 THE/DP .0469 (0) (-.00443) (-.0794) (-.329) (-.564) (-.974) (3.03) (4.01) [-.627; .0648] [-.838; 1.53] <-.357E-6>
 THE/DC .0722 (0) (-.00408) (2.71) [-.732; .0718] [-.602; .244] [1.00; .426] [.847; 2.66] [-.700; 3.30] <.153E-5>

PSI/DA .0269 (.0644) (-.259) (-.536) (-.608) (.698) (.854) (-1.53) (-4.17) (5.75) [-.0261; .144] [.888; 2.19] <.000312>
 PSI/DB .0361 (.0699) (-.200) (-.355) (-.414) (-.431) (-.661) (2.59) [-.160; .307] [-.314; 1.68] [.788; 3.39] <-.000168>
 PSI/DC .294 (.202) (-.262) (-.533) (-.618) (-.695) (1.65) (2.61) [-.287; .194] [-.0500; .196] [-.773; 3.39] <.000256>

YD/DB 1.19 (0) (.0699) (.850) (2.59) [-.528; .0498] [-.632; .265] [-.0206; 2.12] [-.622; 2.75] [-.780; 3.32] <.0120>
 YD/DA .842 (.0644) (-.259) (-.674) (1.22) (2.58) (5.75) [-.0357; .145] [.530; .259] [-.607; 2.69] [.0268; 4.26] <.0316>
 ZD/DC -15.0 (0) (-.209) (-.860) (2.63) [-.817; .0315] [-.405; .181] [-.648; .268] [-.629; 2.68] [-.773; 3.34] <-.00132>

XD/DC -.0864 (0) (.339) (-.552) (2.72) [-.630; .0581] [-.610; .250] [.959; 2.89] [-.653; 3.14] [-.662; 3.27] <-.0113>
 YD/DP 1.74 (-.0794) (-.117) (-.181) (-.259) (-.674) (1.23) (-1.46) (1.74) (2.64) (4.01) [-.0109; .164] [.553; 3.49] <.00553>
 ZD/DB 3.00 (0) (-.00650) (-.0699) (2.59) [-.492; .0513] [-.637; .264] [.0891; 2.18] [-.630; 2.77] [-.778; 3.32] <-.000260>

PHI/DA ; THE/DB -.0763 (0) (-.00726) (-.0644) (-.0699) (-.900) (2.59) (5.75) [-.635; .268] [-.626; 2.68] <-.173E-4>
 PHI/DA ; PSI/DP -.469 (-.0644) (-.0764) (-.0794) (-.259) (-.675) (1.21) (2.56) (4.01) (5.75) [-.0299; .142] <-.461E-4>
 THE/DB ; PSI/DP .148 (-.0165) (-.0691) (-.0699) (-.0794) (-.900) (2.59) (4.01) [-.805; .111] [-.791; 3.45] <-.128E-5>

PHI/DB ; PSI/DP -.0338 (.0699) (-.0760) (-.0794) (-.270) (-.327) (-.370) (1.00) (2.59) (4.01) [-.638; 2.36] <.270E-4>
 PHI/DP ; THE/DB -.0594 (0) (-.0147) (-.0699) (-.0794) (-.897) (2.59) (4.01) [-.714; .217] [-.772; 1.45] <-.445E-5>
 PHI/DC ; THE/DB -.00733 (0) (-.0699) (-.364) (-.618) (-.695) (1.46) (2.59) [-.629; .274] [-.717; 4.00] <-.000876>

THE/DA ; PSI/DP -.0811 (-.00778) (-.0644) (-.0794) (-.417) (-.435) (-.893) (4.01) (5.75) [-.119; .241] <.698E-6>
 THE/DP ; PHI/DA .00286 (0) (-.06896) (-.0644) (-.0794) (-.331) (-.561) (-.581) (-.970) (4.01) (5.75) [-.7.02] <-.223E-5>
 THE/DC ; PHI/DA .0158 (0) (-.0223) (-.0644) (2.38) (5.75) [-.634; .252] [1.00; .426] [-.711; 2.66] <.254E-4>

PSI/DA ; THE/DB -.00412 (-.00730) (-.0644) (-.0699) (-.541) (-.588) (-.891) (1.46) (-1.59) (2.59) (-3.85) (5.75) <-.514E-5>
 PSI/DB ; PHI/DA .0170 (.0644) (-.0699) (-.0707) (-.352) (-.409) (-.512) (-.661) (2.59) (5.75) [-.255; 1.75] <-.120E-4>
 PSI/DC ; THE/DB -.0378 (0) (-.0699) (-.203) (-.541) (-.588) (1.30) (2.59) [-.162; .217] [-.774; 3.36] <-.000319>

PSI/DC ; PHI/DA .141 (.0644) (-.0820) (-.261) (-.533) (-.618) (-.695) (1.65) (2.65) (5.75) [-.0530; .165] <.303E-4>
 XD/DB ; PHI/DA .580 (0) (-.0644) (-.0699) (-.850) (2.59) (5.75) [-.636; .268] [-.0212; 2.12] [-.625; 2.68] <.0767>
 XD/DB ; PSI/DP -1.12 (-.0646) (-.0699) (-.0794) (-.850) (2.59) (4.01) [-.812; .113] [-.0205; 2.12] [-.791; 3.45] <.000242>

YD/DA ; THE/DB -.132 (.00731) (-.0644) (-.0699) (-.900) (2.59) (5.75) [-.524; .260] [-.603; 2.70] [-.0296; 4.26] <-.000521>
 YD/DA ; PSI/DP -.842 (.0644) (-.0794) (-.259) (-.674) (1.22) (2.53) (4.01) (5.75) [-.0299; .142] [-.0106; 4.26] <-.0196>
 ZD/DC ; PHI/DA -7.31 (0) (-.0644) (-.203) (-.859) (2.59) (5.75) [-.454; .163] [-.644; .271] [-.624; 2.64] <-.0166>

ZD/DC ; THE/DB 2.26 (0) (-.00305) (-.0699) (2.59) [-.611; .0535] [-.615; .256] [-.621; 2.73] [-.779; 3.33] <.194E-4>
 ZD/DC ; PSI/DP 14.2 (-.0473) (-.0794) (-.209) (-.861) (2.60) (4.01) [-.631; .119] [-.543; .167] [-.749; 3.40] <-.000457>
 XD/DC ; PHI/DA -.0429 (0) (-.0644) (-.339) (-.553) (2.39) (5.75) [-.634; .257] [-.691; 2.80] [-.756; 3.17] <-.0371>

XD/DC ; THE/DB -.0248 (0) (-.0699) (2.52) (2.59) [-.574; .0297] [-.656; .281] [-.580; 2.80] [-.781; 3.37] <-.704E-4>
 XD/DC ; PSI/DP .0952 (-.0794) (-.104) (-.339) (-.552) (2.53) (4.01) [-.352; .0518] [-.634; 3.01] [-.942; 3.61] <.000470>
 YD/DP ; PHI/DA .527 (.0644) (-.0794) (-.259) (-.673) (1.23) (2.25) (-2.70) (2.85) (4.01) (5.75) [-.0297; .142] <-.00467>

YD/DP ; THE/DB -.273 (.0171) (-.0699) (-.0794) (-.0990) (-.167) (-.896) (-1.46) (1.84) (2.59) (4.01) [-.556; 3.49] <-.000129>
 ZD/DB ; PHI/DA 1.46 (0) (-.00782) (-.0644) (-.0699) (2.59) (5.75) [-.639; .268] [-.0865; 2.18] [-.630; 2.69] <-.00189>
 ZD/DB ; PSI/DP -2.83 (-.0699) (-.0794) (2.59) (4.01) [-.842; .0521] [-.828; .120] [-.0916; 2.18] [-.792; 3.46] <-.000165>

PHI/DA ; THE/DB ; PSI/DP .0715 (.00683) (-.0644) (-.0699) (-.0762) (-.0794) (-.899) (2.59) (4.01) (5.75) <.734E-6>
 PHI/DC ; THE/DB ; PSI/DP .0281 (0) (-.0699) (-.0768) (-.0794) (-.370) (1.00) (1.44) (2.59) (4.01) <.656E-4>
 THE/DC ; PHI/DA ; PSI/DP -.0161 (-.0181) (-.0644) (-.0775) (-.0794) (-.417) (-.435) (2.19) (4.01) (5.75) <-.105E-5>

TABLE IV-5 CONTINUED
AH-IG TRANSFER FUNCTION FACTORS

CASE 63 60KT SCAS ON

CONTROL NUMERATORS CONCLUDED:

PSI/DC ; PHI/DA ; THE/DB	-0.0227	(.00376)	(.0644)	(.0699)	(.0839)	(.541)	(.588)	(1.36)	(2.59)	(5.75)	<-.207E-6>	
XD/DB ; PHI/DA ; PSI/DP	-0.558	(.0544)	(.0699)	(.0763)	(.0794)	(.850)	(2.59)	(4.01)	(5.75)	[-.0211; 2.12]	<-.00346>	
YD/DA ; THE/DB ; PSI/DP	.132	(.00680)	(.0644)	(.0699)	(.0794)	(.900)	(2.59)	(4.01)	(5.75)	[-.00857; 4.25]	<.000311>	
ZD/DC ; PHI/DA ; THE/DB	1.10	(0)	(.00893)	(.0644)	(.0699)	(2.59)	(5.75)	[.630; .261]	[.623; 2.67]	<.000319>		
ZD/DC ; THE/DB ; PSI/DP	-2.13	(-.0461)	(.0699)	(.0794)	(.0840)	(2.59)	(4.01)	[.687; .0643]	[.789; 3.45]	<.234E-4>		
ZD/DC ; PHI/DA ; PSI/DP	7.08	(.0644)	(.0764)	(.0794)	(.193)	(.860)	(2.51)	(4.01)	(5.75)	[.499; .169]	<.000778>	
XD/DC ; PHI/DA ; THE/DB	-0.121	(0)	(.0644)	(.0699)	(2.55)	(2.59)	(5.75)	[.645; .281]	[.597; 2.75]	<-.00124>		
XD/DC ; PHI/DA ; PSI/DP	.0495	(.0644)	(.0771)	(.0794)	(.339)	(.553)	(2.20)	(4.01)	(5.75)	[-.787; 3.17]	<.00187>	
XD/DC ; THE/DB ; PSI/DP	.0226	(.0699)	(.0794)	(-.113)	(2.59)	(2.62)	(4.01)	[.783; .142]	[.769; 3.50]	<-.951E-4>		
YD/DP ; PHI/DA ; THE/DB	-0.0827	(.00682)	(.0644)	(.0699)	(.0794)	(.896)	(2.55)	(2.59)	(-2.71)	(4.01)	(5.75)	<.743E-4>
ZD/DB ; PHI/DA ; PSI/DP	-1.40	(-.00582)	(.0644)	(.0699)	(.0764)	(.0794)	(2.59)	(4.01)	(5.75)	[.0889; 2.18]	<.635E-4>	
ZD/DC ; PHI/DA ; THE/DB ; PSI/DP	-1.06	(.00796)	(.0644)	(.0699)	(.0768)	(.0794)	(2.59)	(4.01)	(5.75)	<-.138E-4>		
XD/DC ; PHI/DA ; THE/DB ; PSI/DP	.0114	(.0644)	(.0699)	(.0752)	(.0794)	(2.59)	(2.69)	(4.01)	(5.75)	<.492E-4>		

GUST NUMERATORS:

PHI/UG	.00281	(0)	(0)	(.258)	(.366)	(.623)	(1.03)	(1.43)	(2.46)	[.632; .272]	[.679; 3.11]	<.000430>	
THE/UG	-.00201	(0)	(0)	(.415)	(.436)	(.954)	[.490; .0374]	[.639; .273]	[.594; 2.67]	[.761; 3.33]	<-.287E-5>		
PSI/UG	.00452	(0)	(0)	(.665)	[.999; .238]	[-.176; .281]	[.998; .544]	[.933; 1.72]	[.765; 3.31]	<.000128>			
PHI/VG	.00520	(0)	(0)	(.232)	(.256)	(.739)	(1.17)	(2.62)	[-.110; .0972]	[.832; .459]	[.843; 1.43]	<.287E-5>	
THE/VG	-.000139	(0)	(0)	(-.00574)	(.0247)	(.126)	(2.51)	[.998; .433]	[.946; 1.44]	[.322; 5.96]	<.858E-7>		
PSI/VG	-.0143	(0)	(0)	(.0349)	(-2.59)	(-5.39)	(-5.93)	(.676)	(1.21)	(2.62)	[.00131; .141]	[.794; 3.44]	<-.210E-4>
PHI/WG	.00280	(0)	(0)	(.259)	(.365)	(.773)	(1.04)	(2.71)	[-.0832; .208]	[.623; .274]	[.638; 3.79]	<.268E-4>	
THE/WG	.00300	(0)	(0)	(.00575)	(.422)	(.430)	[.698; .0647]	[.618; .252]	[.657; 2.92]	[.799; 3.23]	<.748E-7>		
PSI/WG	.00904	(0)	(0)	(.264)	(.531)	(.626)	(.710)	(3.11)	[-.335; .202]	[.110; .216]	[.770; 3.40]	<.803E-5>	
PHI/PG	1.27	(0)	(.259)	(.370)	(.664)	(1.01)	(1.27)	(2.58)	[-.0301; .126]	[.637; .269]	[.631; 2.71]	<.00225>	
THE/PG	-.180	(0)	(-.00659)	(.0449)	(-.0592)	(.415)	(.436)	(.866)	[.658; .284]	[.637; 2.80]	[.615; 2.97]	<-.276E-5>	
PSI/PG	.319	(.269)	(.284)	(.667)	[-.0170; .128]	[.999; .549]	[-.0687; .597]	[.762; 1.90]	[.720; 2.55]	<.000669>			
PHI/QG	.681	(0)	(.260)	(.373)	(1.07)	(2.68)	[-.0952; .210]	[.650; .268]	[.993; .768]	[.611; 2.57]	<.00236>		
THE/QG	.321	(0)	(.00205)	(.415)	(.436)	(.830)	[.637; .0625]	[.618; .266]	[.614; 2.70]	[.825; 3.45]	<.237E-5>		
PSI/QG	-.296	(.253)	(-.351)	(.667)	[-.0759; .182]	[.883; .271]	[.998; .548]	[.769; 1.94]	[.831; 3.81]	<.000700>			
PHI/RG	.507	(0)	(.259)	(.357)	(.679)	(1.06)	(1.31)	(2.51)	(3.32)	[-.0192; .132]	[.614; .283]	<.000519>	
THE/RG	-.0247	(0)	(.0464)	(-.184)	(.351)	[.997; .479]	[.571; .758]	[-.119; 1.04]	[.819; 3.87]	<.000159>			
PSI/RG	.915	(.173)	(.259)	(.540)	(.589)	(.675)	(1.25)	(2.51)	[-.0822; .127]	[-.118; .175]	[.782; 3.41]	<.000158>	
XD/UG	.0228	(0)	(.878)	[.488; .0374]	[.639; .273]	[.980; .420]	[.318; 1.75]	[.590; 2.71]	[.761; 3.35]	<.923E-4>			
ZD/UG	.0740	(0)	(0)	[.494; .0375]	[.638; .266]	[.958; .409]	[.550; 1.59]	[.604; 2.84]	[.764; 3.38]	<.000290>			
YD/VG	.102	(0)	(.130)	(.259)	(.673)	(1.19)	(2.62)	[-.0703; .0811]	[.124; .181]	[.734; 2.26]	[.664; 3.40]	<.922E-4>	
XD/WG	.0397	(0)	(0)	(.336)	(.556)	(-2.25)	[.590; .0619]	[.623; .256]	[.622; 2.90]	[.805; 3.32]	<-.000391>		
ZD/WG	.841	(0)	(.252)	(.763)	(3.01)	[.469; .0370]	[.00719; .152]	[.638; .264]	[.628; 2.75]	[.779; 3.35]	<.923E-4>		
PHI/UG ; THE/DB	-.000398	(0)	(0)	(.0699)	(.366)	(.837)	(1.03)	(2.59)	[.632; .272]	[.649; 3.23]	<-.175E-4>		
THE/UG ; PSI/DP	-.00436	(0)	(0)	(.0765)	(.0794)	(.370)	(.623)	(1.00)	(1.52)	(2.15)	<-.206E-4>		
THE/UG ; PHI/DA	-.000969	(0)	(0)	(.0644)	(.415)	(.436)	(.954)	(5.75)	[.635; .273]	[.607; 2.66]	<-.327E-4>		
THE/UG ; PSI/DP	.00188	(0)	(.0794)	(-.0887)	(.417)	(.435)	(.954)	(4.01)	[.782; .127]	[.749; 3.38]	<-.170E-5>		
PSI/UG ; PHI/DA	.00212	(0)	(0)	(.0644)	(.0775)	(.249)	(.665)	(5.75)	[.998; .543]	[.936; 1.73]	<.895E-5>		
PSI/UG ; THE/DB	-.000637	(0)	(.0699)	(.218)	(.541)	(.588)	(.816)	(2.59)	[-.184; .271]	[.762; 3.29]	<-.522E-5>		
PHI/VG ; THE/DB	-.000813	(0)	(0)	(.00290)	(.0699)	(.214)	(.952)	(2.59)	[.822; .423]	[.848; 1.45]	<-.329E-7>		
PHI/VG ; PSI/DP	-.000501	(0)	(.0794)	(.260)	(.370)	(.768)	(1.00)	(1.14)	(2.81)	(4.01)	[-.0219; .196]	<.170E-5>	
THE/VG ; PHI/DA	-.000575	(0)	(0)	(-.00286)	(.0644)	(.120)	(5.75)	[.998; .433]	[.947; 1.40]	<.268E-7>			
THE/VG ; PSI/DP	.000187	(0)	(0)	(-.00323)	(.0506)	(.0794)	(.417)	(.435)	(1.37)	(4.01)	[.846; 3.55]	<-.304E-7>	
PSI/UG ; PHI/DA	-.00710	(0)	(.0644)	(.254)	(.539)	(.592)	(.677)	(1.21)	(2.58)	(5.75)	[-.0299; .145]	<-.970E-5>	
PSI/VG ; THE/DB	.00225	(0)	(0)	(.00647)	(.0432)	(.0699)	(.541)	(.588)	(.920)	(2.59)	[.790; 3.45]	<.397E-6>	

TABLE IV-5 CONTINUED
 AH-IG TRANSFER FUNCTION FACTORS

CASE 63 60KT SCAS ON

GUST NUMERATORS CONTINUED:

PHI/WG ; THE/DB	- .000503 (0) (-.00434) (.0699) (.365) (1.03) (2.59) [.629; .274] [.674; 3.66] <.149E-6>
PHI/WG ; PSI/DP	- .000066 (0) (.0779) (.0794) (.260) (.370) (.776) (1.00) (2.88) (4.01) [-.0913; .205] <-.135E-5>
THE/WG ; PHI/DA	- .00147 (0) (0) (-.0225) (.0644) (.422) (.431) (5.75) [.638; .259] [.653; 2.72] <.110E-5>
THE/WG ; PSI/DP	- .00287 (0) (-.0523) (.0794) (.110) (.417) (.435) (4.01) [-.579; .0798] [.835; 3.54] <.754E-7>
PSI/WG ; PHI/DA	- .00432 (0) (.0644) (-.0922) (.263) (.531) (.627) (.710) (3.19) (5.75) [-.0491; .179] <-.939E-6>
PSI/WG ; THE/DB	- .00153 (0) (-.00423) (.0699) (.211) (.541) (.588) (2.59) [-.133; .224] [.770; 3.34] <.440E-7>
PHI/PG ; THE/DB	- .195 (0) (.00657) (.0699) (.370) (.912) (1.00) (2.59) [.634; .269] [.626; 2.74] <-.427E-4>
PHI/PG ; PSI/DP	- 1.32 (.0767) (.0794) (.258) (.370) (.664) (1.00) (1.31) (2.45) (4.01) [-.0256; .123] <-.989E-4>
THE/PG ; PHI/DA	- .0846 (0) (.00403) (.0644) (.415) (.436) (.866) (5.75) [.633; .272] [.615; 2.66] <-.104E-4>
THE/PG ; PSI/DP	- .169 (-.00295) (.0794) (-.152) (.417) (.435) (.865) (4.01) [-.734; .160] [.642; 3.15] <.956E-6>
PSI/PG ; PHI/DA	- .115 (0) (-.0354) (.0644) (.128) (.247) (.667) (5.75) [.998; .547] [.836; 1.86] <-.328E-4>
PSI/PG ; THE/DB	- .0435 (.00660) (.0699) (.291) (.541) (.588) (.987) (2.59) [-.0910; .630] [.632; 2.59] <-.127E-4>
PHI/QG ; THE/DB	- .114 (0) (.00439) (.0699) (.373) (.808) (1.01) (2.59) [.638; .266] [.630; 2.54] <-.126E-4>
PHI/QG ; PSI/DP	- .531 (.0760) (.0794) (.260) (.370) (1.00) (2.93) (4.01) [-.0755; .216] [.994; 7.84] <-.000104>
THE/QG ; PHI/DA	- .158 (0) (-.0106) (.0644) (.415) (.436) (.830) (5.75) [-.633; .272] [.619; 2.67] <.889E-4>
THE/QG ; PSI/DP	- .301 (-.0509) (.0794) (.0864) (.417) (.435) (.829) (4.01) [.705; .0722] [.829; 3.53] <.411E-5>
PSI/QG ; PHI/DA	- .162 (.0396) (.0644) (-.0804) (.137) (.244) (.668) (5.75) [.998; .548] [.745; 1.97] <.499E-5>
PSI/QG ; THE/DB	- .0349 (.00442) (.0699) (-.339) (.541) (.588) (1.17) (2.59) [-.827; .268] [.883; 3.85] <-.372E-5>
PHI/RG ; THE/DB	- .0797 (0) (.00445) (.0699) (.357) (.935) (1.09) (2.59) (3.30) [.624; .281] <-.611E-5>
PHI/RG ; PSI/DP	- .316 (.0759) (.0794) (.259) (.370) (.679) (1.00) (1.23) (2.51) (4.01) [-.0357; .139] <-.308E-4>
THE/RG ; PHI/DA	- .00988 (0) (-.0127) (.0644) (.351) (5.75) [.998; .488] [.572; .599] [.105; 1.81] <.455E-5>
THE/RG ; PSI/DP	- .0154 (-.00889) (.0794) (.417) (.435) (.442) (-.571) (4.01) [.541; .232] [.437; 2.35] <.595E-6>
PSI/RG ; PHI/DA	- .446 (.0644) (.0741) (.259) (.540) (.589) (.676) (1.25) (2.51) (5.75) [-.0316; .141] <.428E-4>
PSI/RG ; THE/DB	- .143 (.00441) (.0699) (.174) (.541) (.588) (.921) (2.59) [-.163; .166] [.781; 3.40] <-.185E-5>
XD/UG ; PHI/DA	- .0111 (0) (.0644) (.877) (5.75) [.636; .273] [.980; .420] [.307; 1.77] [.605; 2.67] <.00105>
XD/UG ; THE/DB	- .00119 (0) (.0699) (.808) (2.59) [.571; .0308] [.650; .277] [.611; 2.74] [.775; 3.33] <-.106E-5>
XD/UG ; PSI/DP	- .0213 (.0794) (-.0894) (.877) (4.01) [-.784; .127] [.980; .420] [.310; 1.75] [.752; 3.43] <.546E-4>
ZD/UG ; PHI/DA	- .0358 (0) (0) (.0644) (5.75) [.639; .269] [.957; .409] [.531; 1.64] [.612; 2.76] <.00331>
ZD/UG ; THE/DB	- .00560 (0) (0) (.0699) (2.59) [.355; .0387] [.687; .289] [.643; 2.86] [.795; 3.32] <-.114E-4>
ZD/UG ; PSI/DP	- .0694 (0) (.0794) (-.0941) (4.01) [-.802; .123] [.958; .409] [.532; 1.63] [.765; 3.53] <.000172>
YD/VG ; PHI/DA	- .0454 (0) (.0644) (.0735) (.259) (.673) (1.19) (2.62) (5.75) [-.0227; .141] [.667; 2.28] <.694E-4>
YD/VG ; THE/DB	- .0161 (0) (.00289) (.0699) (.129) (.893) (2.59) [.151; .135] [.741; 2.28] [.661; 3.38] <-.106E-5>
YD/VG ; PSI/DP	- .0717 (.0794) (-.120) (-.125) (-.259) (.673) (1.20) (2.59) (4.01) [.0416; .157] [.803; 3.45] <.546E-4>
XD/WG ; PHI/DA	- .0215 (0) (0) (.0644) (.336) (.557) (-2.04) (5.75) [.637; .262] [.634; 2.75] <-.00159>
XD/WG ; THE/DB	- .00304 (0) (0) (.0699) (2.59) [-.535; .0389] [.643; .275] [.611; 2.74] [.778; 3.33] <-.525E-5>
XD/WG ; PSI/DP	- .00367 (0) (-.0157) (.0794) (.336) (.556) (-2.35) (4.01) [-9.77] [.905; .0824] [.829; 3.66] <-.714E-5>
ZD/WG ; PHI/DA	- .409 (0) (.0644) (.252) (.764) (3.04) (5.75) [-.0527; .151] [.640; .269] [.628; 2.68] <.00105>
ZD/WG ; THE/DB	- .141 (0) (.00273) (.0699) (2.59) [.564; .0508] [.632; .265] [.627; 2.76] [.780; 3.32] <-.106E-5>
ZD/WG ; PSI/DP	- .793 (.0794) (-.0842) (.252) (.764) (3.04) (4.01) [.815; .123] [-.0391; .155] [.794; 3.48] <.546E-4>
XD/UG ; ZD/DC	- .336 (0) [.554; .0359] [.624; .264] [.976; .417] [.346; 1.76] [.578; 2.68] [.761; 3.35] <-.00132>
YD/VG ; ZD/DC	- 1.53 (0) (-.0394) (.201) (.861) (2.63) [-.729; .144] [.273; .201] [.731; 2.22] [.664; 3.40] <-.00132>
PHI/UG ; THE/DB ; PSI/DP	- .000616 (0) (.0699) (.0760) (.0794) (.370) (.838) (1.00) (2.59) (4.01) <.838E-6>
THE/UG ; PHI/DA ; PSI/DP	- .000922 (0) (.0644) (.0764) (.0794) (.417) (.435) (.954) (4.01) (5.75) <.143E-5>
PSI/UG ; PHI/DA ; THE/DB	- .000299 (0) (.0644) (.0699) (.0719) (.541) (.588) (.815) (2.59) (5.75) <-.374E-6>
PHI/VG ; THE/DB ; PSI/DP	- .853E-4 (0) (.0168) (.0699) (.0794) (.370) (1.00) (1.30) (2.59) (4.01) <-.397E-7>
THE/VG ; PHI/DA ; PSI/DP	- .941E-4 (0) (-.00791) (.0644) (.0794) (.417) (.435) (1.37) (4.01) (5.75) <-.217E-7>
PSI/VG ; PHI/DA ; THE/DB	- .00112 (0) (-.00730) (.0644) (.0699) (.541) (.588) (.920) (2.59) (5.75) <.160E-6>
PHI/WG ; THE/DB ; PSI/DP	- .00105 (0) [-.00321] (.0699) (.0776) (.0794) (.370) (1.00) (2.59) (4.01) <-.558E-8>
THE/WG ; PHI/DA ; PSI/DP	- .00144 (0) (.0192) (.0644) (.0785) (.0794) (.417) (.435) (4.01) (5.75) <-.464E-7>
PSI/WG ; PHI/DA ; THE/DB	- .000729 (0) (-.00185) (.0644) (.0699) (.0983) (.541) (.588) (2.59) (5.75) <-.284E-8>

TABLE IV-5 CONTINUED
AH-IG TRANSFER FUNCTION FACTORS

CASE 63 60KT SCAS ON

GUST NUMERATORS CONCLUDED:

PHI/PG ; THE/DB ; PSI/DP	.200	(.00620)	(.0699)	(.0763)	(.0794)	(.370)	(.910)	(1.00)	(2.59)	(4.01)	<.184E-5>
THE/PG ; PHI/DA ; PSI/DP	.3839	(.00403)	(.0644)	(.0753)	(.0794)	(.417)	(.435)	(.865)	(4.01)	(5.75)	<.457E-6>
PSI/PG ; PHI/DA ; THE/DB	-.0160	(.00406)	(.0644)	(.0699)	(.0867)	(.541)	(.588)	(.987)	(2.59)	(5.75)	<-.119E-6>
PHI/QG ; THE/DB ; PSI/DP	.0941	(.00332)	(.0699)	(.0763)	(.0794)	(.370)	(.816)	(1.00)	(2.59)	(4.01)	<.413E-6>
THE/QG ; PHI/DA ; PSI/DP	-.151	(.0105)	(.0644)	(.0763)	(.0794)	(.417)	(.435)	(.829)	(4.01)	(5.75)	<-.214E-5>
PSI/QG ; PHI/DA ; THE/DB	.0200	(.0114)	(.0644)	(.0699)	(.0841)	(.541)	(.588)	(1.17)	(2.59)	(5.75)	<.478E-6>
PHI/RG ; THE/DB ; PSI/DP	.0490	(.00566)	(.0699)	(.0759)	(.0794)	(.370)	(.946)	(1.00)	(2.59)	(4.01)	<.427E-6>
THE/RG ; PHI/DA ; PSI/DP	.00691	(-.0193)	(.0644)	(.0794)	(.0819)	(.417)	(.435)	(.471)	(4.01)	(5.75)	<-.109E-6>
PSI/RG ; PHI/DA ; THE/DB	-.0696	(.00645)	(.0644)	(.0699)	(.0740)	(.541)	(.588)	(.921)	(2.59)	(5.75)	<-.652E-6>
XD/UG ; PHI/DA ; THE/DB	-.000581	(0)	(.0644)	(.0699)	(.808)	(2.59)	(5.75)	[-.640; .276]	[.615; 2.68]	<-.173E-4>	
XD/UG ; PHI/DA ; PSI/DP	-.0106	(.0644)	(.0764)	(.0794)	(.877)	(4.01)	(5.75)	[.980; .420]	[.300; 1.77]	<-.461E-4>	
XD/UG ; THE/DB ; PSI/DP	-.00111	(.0699)	(.0794)	(-.106)	(.808)	(2.59)	(4.01)	[.783; .140]	[.782; 3.45]	<-.128E-5>	
ZD/UG ; PHI/DA ; THE/DB	-.00272	(0)	(0)	(.0644)	(.0699)	(2.59)	(5.75)	[.658; .287]	[.644; 2.75]	<-.000113>	
ZD/UG ; PHI/DA ; PSI/DP	-.0342	(0)	(.0644)	(.0764)	(.0794)	(4.01)	(5.75)	[.957; .409]	[.510; 1.68]	<-.000145>	
ZD/UG ; THE/DB ; PSI/DP	.00526	(0)	(.0699)	(.0794)	(-.144)	(2.59)	(4.01)	[.781; .170]	[.813; 3.49]	<-.154E-4>	
YD/VG ; PHI/DA ; THE/DB	-.00712	(0)	(.00658)	(.0644)	(.0699)	(.0753)	(.892)	(2.59)	(5.75)	[.669; 2.29]	<-.111E-5>
YD/VG ; PHI/DA ; PSI/DP	-.0361	(.0644)	(.0794)	(.259)	(.673)	(1.20)	(2.55)	(4.01)	(5.75)	[.0297; .142]	<-.461E-4>
YD/VG ; THE/DB ; PSI/DP	.0112	(.0164)	(.0699)	(.0794)	(-.105)	(.107)	(.894)	(2.59)	(4.01)	[.800; 3.47]	<-.128E-5>
XD/WG ; PHI/DA ; THE/DB	-.00148	(0)	(0)	(.0644)	(.0699)	(2.59)	(5.75)	[.637; .276]	[.615; 2.68]	<-.543E-4>	
XD/WG ; PHI/DA ; PSI/DP	-.0221	(0)	(.0644)	(.0778)	(.0794)	(.337)	(.557)	(-2.03)	(4.01)	(5.75)	<.770E-4>
XD/WG ; THE/DB ; PSI/DP	.00284	(0)	(.0699)	(.0794)	(-.0938)	(2.59)	(4.01)	[.787; .132]	[.785; 3.45]	<-.317E-5>	
ZD/WG ; PHI/DA ; THE/DB	-.0686	(0)	(.00727)	(.0644)	(.0699)	(2.59)	(5.75)	[.637; .268]	[.628; 2.69]	<-.173E-4>	
ZD/WG ; PHI/DA ; PSI/DP	-.394	(.0644)	(.0764)	(.0794)	(.252)	(.764)	(3.03)	(4.01)	(5.75)	[-.0466; .149]	<-.461E-4>
ZD/WG ; THE/DB ; PSI/DP	.133	(.0166)	(-.0696)	(.0699)	(.0794)	(2.59)	(4.01)	[.811; .110]	[.793; 3.46]	<-.128E-5>	
XD/UG ; ZD/DC ; PHI/DA	-.163	(0)	(.0644)	(5.75)	[.630; .266]	[.976; .417]	[.329; 1.78]	[.598; 2.65]	<-.0166>		
XD/UG ; ZD/DC ; THE/DB	.0180	(0)	(.0699)	(2.59)	[.573; .0307]	[.649; .276]	[.606; 2.73]	[.775; 3.34]	<.194E-4>		
XD/UG ; ZD/DC ; PSI/DP	.314	(-.0661)	(.0794)	(4.01)	[.818; .105]	[.976; .417]	[.332; 1.76]	[.746; 3.42]	<-.000457>		
YD/VG ; ZD/DC ; PHI/DA	-.677	(0)	(.0585)	(.0644)	(.201)	(.860)	(2.59)	(5.75)	[.518; .179]	[.665; 2.26]	<-.00108>
YD/VG ; ZD/DC ; THE/DB	.230	(0)	(.00328)	(.0699)	(-.112)	(2.59)	[.241; .146]	[.734; 2.27]	[.659; 3.38]	<.194E-4>	
YD/VG ; ZD/DC ; PSI/DP	1.09	(-.0602)	(.0794)	(.130)	(.188)	(.862)	(2.59)	(4.01)	[.416; .186]	[.801; 3.41]	<-.000457>
XD/UG ; PHI/DA ; THE/DB ; PSI/DP	.000556	(.0644)	(.0699)	(.0766)	(.0794)	(.808)	(2.59)	(4.01)	(5.75)	<.734E-6>	
ZD/UG ; PHI/DA ; THE/DB ; PSI/DP	.00260	(0)	(.0644)	(.0699)	(.0772)	(.0794)	(2.59)	(4.01)	(5.75)	<.429E-5>	
YD/VG ; PHI/DA ; THE/DB ; PSI/DP	.00565	(.00682)	(.0644)	(.0699)	(.0794)	(.893)	(2.59)	(4.01)	(5.75)	<.734E-6>	
XD/WG ; PHI/DA ; THE/DB ; PSI/DP	.00142	(0)	(.0644)	(.0699)	(.0746)	(.0794)	(2.59)	(4.01)	(5.75)	<.225E-5>	
ZD/WG ; PHI/DA ; THE/DB ; PSI/DP	.0660	(.00683)	(.0644)	(.0699)	(.0763)	(.0794)	(2.59)	(4.01)	(5.75)	<.734E-6>	
XD/UG ; ZD/DC ; PHI/DA ; THE/DB	.00880	(0)	(.0644)	(.0699)	(2.59)	(5.75)	[.639; .275]	[.611; 2.67]	<.000319>		
YD/VG ; ZD/DC ; PHI/DA ; THE/DB	.102	(0)	(.00783)	(.0644)	(.0699)	(.0724)	(2.59)	(5.75)	[.665; 2.29]	<.203E-4>	
YD/VG ; ZD/DC ; PHI/DA ; PSI/DP	.544	(.0644)	(.0794)	(.197)	(.861)	(2.51)	(4.01)	(5.75)	[.502; .169]	<.000778>	
XD/WG ; ZD/DC ; PHI/DA ; THE/DB	.0322	(0)	(.0644)	(.0699)	(2.59)	(5.75)	[.641; .283]	[.603; 2.68]	<.00124>		
XD/UG ; ZD/DC ; PHI/DA ; THE/DB ; PSI/DP	-.00842	(.0644)	(.0699)	(.0770)	(.0794)	(2.59)	(4.01)	(5.75)	<-.138E-4>		
YD/VG ; ZD/DC ; PHI/DA ; THE/DB ; PSI/DP	-.0814	(.00796)	(.0644)	(.0699)	(.0794)	(2.59)	(4.01)	(5.75)	<-.138E-4>		
XD/WG ; ZD/DC ; PHI/DA ; THE/DB ; PSI/DP	-.0306	(.0644)	(.0699)	(.0752)	(.0794)	(2.59)	(4.01)	(5.75)	<-.492E-4>		

TABLE IV-5 CONTINUED
AH-IG TRANSFER FUNCTION FACTORS

CASE 64 80KT SCAS OFF

DENOMINATOR: (0) (.0506) (1.43) [.00550;.238] [.594;1.00] [.365;1.43] <-.00851>

CONTROL NUMERATORS:

PHI/DA .490 (0) [-.0366;.281] [.714;.968] [.395;1.45] <-.0762>
THE/DB -.161 (0) (.00864) (.0485) [.999;1.15] [.361;1.44] <-.000187>
PSI/DP -1.02 (-.161) (-.295) (1.46) [.0104;.255] [.578;.995] <-.00452>

PHI/DB .0471 (0) (-.186) (-.186) [.303;1.45] [.678;2.62] <-.0237>
THE/DA .0780 (0) (-.0285) (-.0403) (1.02) [.394;1.42] <-.000183>

PHI/DA ;THE/DB -.0788 (0) (.0122) (1.06) [.398;1.47] <-.00218>
PHI/DA ;PSI/DP -.508 (.0998) [-.0348;.281] [.704;.949] <-.00359>
THE/DB ;PSI/DP .164 (.0159) (-.159) (.322) [.999;1.12] <-.000168>

PHI/DB ;PSI/DP -.0665 (.0977) (-.198) (-.201) [.483;2.29] <-.00135>
PHI/DP ;THE/DB -.0625 (0) (.0154) (1.14) [.563;.838] <-.000774>
PHI/DC ;THE/DB -.00602 (0) (.00772) (3.31) [.479;2.09] <-.000670>

THE/DA ;PSI/DP -.0788 (-.0814) (1.02) [.554;.135] <.000119>
THE/DP ;PHI/DA .00635 (0) (-1.07) (1.44) [-.274;.223] <-.000489>
THE/DC ;PHI/DA .0114 (0) (.0242) (4.09) [.449;1.49] <.00251>

PSI/DA ;THE/DB -.00357 (.0122) (1.02) (-1.45) (1.65) (-4.68) <-.000496>
PSI/DB ;PHI/DA .0225 (.0899) (-.295) (-.344) [-.116;2.01] <-.000825>
XD/DB ;PHI/DA .541 (0) (.995) [.397;1.47] [.0217;2.22] <.5.76>

YD/DA ;THE/DB -.137 (.0122) (1.06) [.320;1.41] [.0313;4.36] <-.0670>
ZD/DB ;PHI/DA 2.09 (0) (.0172) [.405;1.48] [.0990;2.29] <.414>
XD/DC ;PHI/DA .0446 (0) (-4.71) [.464;1.57] [.488;2.54] <-3.33>

YD/DP ;THE/DB -.294 (.0159) (1.15) [-.839;1.11] [.746;1.84] <-.0226>
ZD/DC ;PHI/DA -8.06 (0) (-.110) [.142;.923] [.424;1.40] <-1.49>

PHI/DA ;THE/DB ;PSI/DP .0815 (.0115) (-.0997) (1.04) <.975E-4>
PHI/DC ;THE/DB ;PSI/DP .0225 (.00803) (.101) (2.27) <.413E-4>
THE/DC ;PHI/DA ;PSI/DP -.0134 (.0212) (-.100) (3.69) <-.000105>

PSI/DC ;PHI/DA ;THE/DB -.0205 (.00861) (.108) (1.68) <-.319E-4>
XD/DB ;PHI/DA ;PSI/DP -.559 (.0997) (-.992) [.0210;2.22] <-.272>
YD/DA ;THE/DB ;PSI/DP .146 (.0115) (1.04) [-.00678;4.28] <.0319>

ZD/DC ;PHI/DA ;THE/DB 1.25 (0) (.0114) [.401;1.43] <.0290>
ZD/DC ;PHI/DA ;PSI/DP 8.39 (-.101) (.113) [.160;.876] <.0735>
XD/DC ;PHI/DA ;THE/DB -.0197 (0) (1.83) [.341;1.62] <-.0943>

XD/DC ;PHI/DA ;PSI/DP -.0327 (.0998) (-5.70) [.561;2.92] <.159>
YD/DP ;PHI/DA ;THE/DB -.0907 (.0115) (1.04) (3.38) (-3.59) <.0132>
ZD/DB ;PHI/DA ;PSI/DP -2.17 (.0182) (-.0999) [.0970;2.30] <-.0208>

ZD/DC ;PHI/DA ;THE/DB ;PSI/DP -1.29 (.0107) (-.100) <-.00138>
XD/DC ;PHI/DA ;THE/DB ;PSI/DP .0200 (.0978) (1.87) <.00365>

TABLE IV-5 CONTINUED
AH-1G TRANSFER FUNCTION FACTORS

CASE 64 80KT SCAS ON

DENOMINATOR: (0) (-.262) (-.668) (1.68) (2.41) [.549; .0301] [.0291; .137] [-.690; .297] [-.631; 2.88] [.771; 3.31] <-.968E-4>

CONTROL NUMERATORS:

PHI/DA .490 (0) (.0644) (-.262) (.668) (1.72) (2.30) (5.75) [-.00117; .138] [.684; .297] [-.630; 2.82] <.00167>
THE/DB -.161 (0) (.00535) (.0699) (1.04) (2.59) [.632; .0360] [.689; .298] [-.626; 2.92] [.771; 3.32] <-.175E-4>
PSI/DP -1.02 (.0794) (-.0962) (.262) (.668) (1.70) (2.36) (4.01) [.0191; .137] [-.816; .143] [-.788; 3.40] <.965E-4>

PHI/DB .0471 (0) (-.0699) (.186) (-.189) (.370) (1.03) (2.59) [-.680; .293] [-.452; 2.10] [-.772; 3.48] <-.000523>
THE/DA .0788 (0) (-.0133) (-.0629) (-.0644) (1.02) (5.75) [-.529; .304] [-.999; .430] [-.623; 2.76] <-.325E-5>

PHI/DA ; THE/DB -.0788 (0) (.0122) (-.0644) (-.0699) (1.04) (2.59) (5.75) [-.682; .297] [-.630; 2.84] <-.478E-4>
PHI/DA ; PSI/DP -.508 (.0644) (-.0794) (-.0997) (-.262) (.668) (1.77) (2.19) (4.01) (5.75) [-.00166; .138] <-.767E-4>
THE/DB ; PSI/DP .164 (-.0159) (-.0699) (-.0794) (-.0958) (1.04) (2.59) (4.01) [-.814; .142] [-.781; 3.44] <-.358E-5>

PHI/DB ; PSI/DP -.0665 (-.0699) (-.0794) (-.0977) (.198) (-.201) (.370) (1.00) (2.59) (4.01) [-.483; 2.29] <.288E-4>
PHI/DP ; THE/DB -.0625 (0) (-.0154) (-.0699) (-.0794) (1.04) (2.59) (4.01) [-.757; .338] [-.712; 1.58] <-.165E-4>
PHI/DC ; THE/DB -.00602 (0) (-.00773) (-.0699) (-.364) (1.03) (2.59) (3.56) [-.672; .292] [-.964; 3.95] <-.148E-4>

THE/DA ; PSI/DP -.0788 (.0644) (-.0794) (-.0814) (.417) (.435) (1.02) (4.01) (5.75) [-.554; .135] <.255E-5>
THE/DP ; PHI/DA .00635 (0) (.0644) (-.0794) (.301) (.599) (1.26) (4.01) (-4.04) (5.75) [-.0374; .126] <-.109E-4>
THE/DC ; PHI/DA .0114 (0) (-.0241) (-.0644) (-.426) (-.426) (4.55) (5.75) [-.686; .292] [-.710; 2.77] <.550E-4>

PSI/DA ; THE/DB -.00357 (-.0122) (-.0644) (-.0699) (-.541) (.598) (1.02) (-1.45) (1.65) (2.59) (-4.68) (5.75) <-.106E-4>
PSI/DB ; PHI/DA .0225 (.0644) (-.0699) (-.0899) (-.325) (-.335) (.411) (-.676) (2.59) (5.75) [-.0925; 2.07] <-.176E-4>
XD/DB ; PHI/DA .541 (0) (-.0644) (-.0699) (-.992) (2.59) (5.75) [-.684; .297] [-.0211; 2.22] [-.628; 2.84] <.127>

YD/DA ; THE/DB -.137 (-.0122) (-.0644) (-.0699) (1.04) (2.59) (5.75) [-.556; .287] [-.601; 2.85] [-.0351; 4.27] <-.00143>
ZD/DB ; PHI/DA 2.09 (0) (-.0172) (-.0544) (-.0699) (2.59) (5.75) [-.685; .297] [-.0957; 2.29] [-.633; 2.86] <.00912>
XD/DC ; PHI/DA .0446 (0) (-.0644) (-.348) (-.530) (-1.75) (5.75) [-.686; .297] [-.774; 3.06] [-.600; 4.10] <-.0736>

YD/DP ; THE/DB -.294 (-.0160) (-.0699) (-.0794) (-.128) (-.199) (1.03) (2.28) (-2.29) (2.59) (4.01) [-.595; 3.61] <-.000483>
ZD/DC ; PHI/DA -8.06 (0) (-.0644) (-.151) (-.914) (2.59) (5.75) [-.707; .217] [-.654; .290] [-.635; 2.79] <-.0327>

PHI/DA ; THE/DB ; PSI/DP .0815 (.0115) (-.0644) (-.0699) (-.0794) (-.0997) (1.04) (2.59) (4.01) (5.75) <.208E-5>
PHI/DC ; THE/DB ; PSI/DP .0225 (.00803) (-.0699) (-.0794) (-.101) (-.370) (1.00) (2.27) (2.59) (4.01) <.881E-6>
THE/DC ; PHI/DA ; PSI/DP -.0134 (-.0212) (-.0644) (-.0794) (-1.00) (-.417) (-.435) (3.69) (4.01) (5.75) <-.224E-5>

PSI/DC ; PHI/DA ; THE/DB -.0205 (-.00861) (-.0644) (-.0699) (-.108) (-.541) (-.588) (1.68) (2.59) (5.75) <-.681E-6>
XD/DB ; PHI/DA ; PSI/DP -.559 (-.0644) (-.0699) (-.0794) (-.0997) (-.992) (2.59) (4.01) (5.75) [-.0210; 2.22] <-.00581>
YD/DA ; THE/DB ; PSI/DP .146 (.0115) (-.0644) (-.0699) (-.0794) (1.04) (2.59) (4.01) (5.75) [-.00678; 4.28] <.000680>

ZD/DC ; PHI/DA ; THE/DB 1.25 (0) (-.0114) (-.0644) (-.0699) (2.59) (5.75) [-.679; .289] [-.629; 2.82] <.000636>
ZD/DC ; PHI/DA ; PSI/DP 8.39 (.0644) (-.0794) (-.101) (-.157) (-.915) (2.50) (4.01) (5.75) [-.662; .210] <.00157>
XD/DC ; PHI/DA ; THE/DB -.0197 (0) (-.0644) (-.0699) (1.85) (2.59) (5.75) [-.696; .319] [-.593; 2.88] <-.00206>

XD/DC ; PHI/DA ; PSI/DP -.0327 (-.0644) (-.0794) (-.0998) (-.348) (-.530) (-1.76) (4.01) (5.75) [-.928; 5.21] <.00338>
YD/DP ; PHI/DA ; THE/DB -.0907 (-.0115) (-.0644) (-.0699) (-.0794) (1.04) (2.59) (3.38) (-3.59) (4.01) (5.75) <.000281>
ZD/DB ; PHI/DA ; PSI/DP -2.17 (-.0182) (-.0644) (-.0699) (-.0794) (-.0999) (2.59) (4.01) (5.75) [-.0970; 2.30] <-.000445>

ZD/DC ; PHI/DA ; THE/DB ; PSI/DP -1.29 (-.0107) (-.0644) (-.0699) (-.0794) (-1.00) (2.59) (4.01) (5.75) <-.295E-4>
XD/DC ; PHI/DA ; THE/DB ; PSI/DP .0200 (-.0644) (-.0699) (-.0794) (-.0978) (1.87) (2.59) (4.01) (5.75) <.779E-4>

TABLE IV-5 CONTINUED
AH-IG TRANSFER FUNCTION FACTORS

CASE 65 100KT SCAS OFF

DENOMINATOR: (0) (.0417) (1.35) [-.0567; .220] [-.505; 1.21] [.378; 1.60] <-.0101>

CONTROL NUMERATORS:

PHI/DA .484 (0) [.0320; .259] [.611; 1.18] [.401; 1.63] <.118>
THE/DB -.163 (0) (.0152) (.0410) [.993; 1.16] [-.375; 1.61] <-.000357>
PSI/DP -1.07 (-.190) (.384) (1.36) [-.0630; .233] [.484; 1.18] <.00812>

PHI/DB .0608 (0) (-.115) (.138) [-.337; 1.66] [-.528; 2.76] <-.0202>
THE/DA .0797 (0) (-.0348) (.0382) (1.14) [-.412; 1.58] <-.000300>

PHI/DA ; THE/DB -.0790 (0) (.0184) (1.21) [-.399; 1.65] <-.00478>
PHI/DA ; PSI/DP -.531 (.122) [.0305; .261] [.607; 1.14] <-.00576>
THE/DB ; PSI/DP .175 (.0201) (-.191) (.463) [.996; 1.08] <-.000365>

PHI/DB ; PSI/DP -.0891 (.111) (-.131) (.165) [-.399; 2.48] <.00132>
PHI/DP ; THE/DB -.0687 (0) (.0199) (1.34) [-.480; 1.07] <-.00211>
PHI/DC ; THE/DB .00307 (0) (.0153) (-9.69) [.589; 1.94] <-.00171>

THE/DA ; PSI/DP -.0852 (-.147) (1.15) [-.963; .122] <.000214>
THE/DP ; PHI/DA .00613 (0) (2.09) (-2.54) [.996; .184] <-.00111>
THE/DC ; PHI/DA .0584 (0) (.0304) [-.464; 1.68] <.00499>

PSI/DA ; THE/DB -.00421 (.0184) (1.16) (-1.53) (1.85) (-3.39) <-.000863>
PSI/DB ; PHI/DA .0260 (.101) (-.255) (.300) [.00773; 2.05] <-.000838>
XD/DB ; PHI/DA .452 (0) (1.21) [-.398; 1.66] [-.0151; 2.36] <8.35>

YD/DA ; THE/DB -.137 (.0184) (1.22) [-.312; 1.55] [.0394; 4.44] <-.146>
ZD/DB ; PHI/DA 2.71 (0) (.0333) [.405; 1.67] [.0998; 2.41] <1.46>
XD/DC ; PHI/DA .203 (0) (-2.09) [-.533; 1.71] [.332; 2.06] <-5.25>

YD/DP ; THE/DB -.316 (.0201) (-1.02) (1.47) (-1.74) [.879; 1.93] <-.0617>
ZD/DC ; PHI/DA -8.55 (0) (.105) [.103; 1.12] [-.443; 1.59] <-2.84>

PHI/DA ; THE/DB ; PSI/DP .0863 (.0179) (.122) (1.19) <.000225>
PHI/DC ; THE/DB ; PSI/DP .0158 (.0155) (.124) (3.80) <.000116>
THE/DC ; PHI/DA ; PSI/DP -.00747 (.0279) (.122) (8.52) <-.000216>

PSI/DC ; PHI/DA ; THE/DB -.0220 (.0157) (.131) (1.76) <-.796E-4>
XD/DB ; PHI/DA ; PSI/DP -.493 (.122) (1.20) [.0143; 2.36] <-.404>
YD/DA ; THE/DB ; PSI/DP .155 (.0178) (1.19) [-.00371; 4.30] <.0610>

ZD/DC ; PHI/DA ; THE/DB 1.37 (0) (.0152) [-.406; 1.59] <.0528>
ZD/DC ; PHI/DA ; PSI/DP 9.41 (.115) (.119) [-.147; 1.05] <.141>
XD/DC ; PHI/DA ; THE/DB -.0380 (0) (1.23) [-.333; 1.73] <-.141>

XD/DC ; PHI/DA ; PSI/DP -.211 (.122) (-2.12) [-.462; 2.13] <.247>
YD/DP ; PHI/DA ; THE/DB -.0951 (.0179) (1.18) (4.21) (-4.48) <.0379>
ZD/DB ; PHI/DA ; PSI/DP -2.96 (.0340) (.122) [-.0963; 2.42] <-.0720>

ZD/DC ; PHI/DA ; THE/DB ; PSI/DP -1.49 (.0154) (.123) <-.00280>
XD/DC ; PHI/DA ; THE/DB ; PSI/DP .0413 (.120) (1.12) <.00554>

TABLE IV-5 CONTINUED
AH-IG TRANSFER FUNCTION FACTORS

CASE 65 IOOKT SCAS ON

DENOMINATOR: (0) (.267) (.658) [.612; .0228] [.0526; .137] [-.731; .320] [.949; 2.26] [.630; 3.01] [.758; 3.23] <-.866E-4>

CONTROL NUMERATORS:

PHI/DA	.484	(0)	(.0644)	(.267)	(.659)	(5.75)	[.0353; .138]	[.721; .319]	[.939; 2.21]	[.635; 2.95]	<.00260>		
THE/DB	-.163	(0)	(.0103)	(.0679)	(1.19)	(2.59)	[.714; .0270]	[.730; .320]	[.621; 3.07]	[.764; 3.27]	<-.275E-5>		
PSI/DP	-1.07	(.0794)	(-.109)	(.267)	(.658)	(4.01)	[.3517; .136]	[.331; .160]	[.946; 2.24]	[.771; 3.33]	<.000173>		
PHI/DB	.0608	(0)	(.0699)	(-.117)	(.138)	(.371)	(1.02)	(2.59)	[.721; .312]	[.404; 2.33]	[.706; 3.55]	<-.000449>	
THE/DA	.0812	(0)	(-.0161)	(.0595)	(.0644)	(1.15)	(5.75)	[.635; .290]	[.999; .433]	[.631; 2.88]	<-.430E-5>		
PHI/DA ; THE/DB	-.0790	(0)	(.0184)	(.0644)	(.0699)	(1.19)	(2.59)	(5.75)	[.721; .319]	[.633; 2.98]	<-.000105>		
PHI/DA ; PSI/DP	-.531	(.0644)	(.0794)	(.122)	(.267)	(.659)	(4.01)	(5.75)	[.0336; .139]	[.935; 2.18]	<-.000123>		
THE/DB ; PSI/DP	.175	(.0201)	(.0679)	(.0794)	(-.109)	(1.19)	(2.59)	(4.01)	[.833; .160]	[.764; 3.41]	<-.780E-5>		
PHI/DB ; PSI/DP	-.0891	(.0699)	(.0794)	(.111)	(-.131)	(.165)	(.370)	(1.00)	(2.59)	(4.01)	[.379; 2.48]	<.282E-4>	
PHI/DP ; THE/DB	-.0687	(0)	(.0199)	(.0679)	(.0794)	(1.21)	(2.59)	(4.01)	[.825; .402]	[.665; 1.71]	<-.451E-4>		
PHI/DC ; THE/DB	-.0528	(0)	(.0153)	(.0699)	(.363)	(1.02)	(2.59)	[.705; .305]	[.817; 2.74]	<-.380E-4>			
THE/DA ; PSI/DP	-.0852	(.0644)	(.0794)	(-.147)	(.417)	(.435)	(1.15)	(4.01)	(5.75)	[.963; .122]	<.456E-5>		
THE/DP ; PHI/DA	.00613	(0)	(.0644)	(.0794)	(.236)	(.620)	(1.65)	(4.01)	(5.75)	[-.6.12; .929; .153]	<-.249E-4>		
THE/DC ; PHI/DA	.0836	(0)	(.0303)	(.0644)	(.426)	(.428)	(5.75)	[.727; .316]	[.691; 2.81]	<.000135>			
PSI/DA ; THE/DB	-.00421	(.0184)	(.0644)	(.0699)	(.541)	(.588)	(1.16)	(-1.53)	(1.85)	(2.59)	(-3.39)	(5.75)	<-.184E-4>
PSI/DB ; PHI/DA	.0260	(.0644)	(.0699)	(.101)	(-.249)	(.709)	(2.59)	(5.75)	[.993; .358]	[.0301; 2.12]	<-.179E-4>		
XD/DB ; PHI/DA	.452	(0)	(.0644)	(.0699)	(1.20)	(2.59)	(5.75)	[.722; .318]	[.0147; 2.36]	[.630; 2.98]	<.184>		
YD/DA ; THE/DB	-.137	(.0184)	(.0644)	(.0699)	(1.20)	(2.59)	(5.75)	[.580; .305]	[.594; 2.96]	[.0481; 4.32]	<-.00311>		
ZD/DB ; PHI/DA	2.71	(0)	(.0333)	(.0644)	(.0699)	(2.59)	(5.75)	[.723; .318]	[.0963; 2.41]	[.635; 3.00]	<.0321>		
XD/DC ; PHI/DA	.203	(0)	(.0644)	(.356)	(.509)	(-1.09)	(5.75)	[.727; .321]	[.768; 2.71]	[.523; 3.21]	<-.116>		
YD/DP ; THE/DB	-.316	(.0201)	(.0699)	(.0794)	(.135)	(-.209)	(1.18)	(2.59)	(2.68)	(-2.99)	(4.01)	[.616; 3.67]	<-.00132>
ZD/DC ; PHI/DA	-8.55	(0)	(.0644)	(.126)	(.996)	(2.55)	(5.75)	[.799; .268]	[.648; .318]	[.642; 2.91]	<-.0625>		
PHI/DA ; THE/DB ; PSI/DP	.0863	(.0179)	(.0644)	(.0699)	(.0794)	(.122)	(1.19)	(2.59)	(4.01)	(5.75)	<.479E-5>		
PHI/DC ; THE/DB ; PSI/DP	.0158	(.0155)	(.0699)	(.0794)	(.124)	(.370)	(1.00)	(2.59)	(3.80)	(4.01)	<.247E-5>		
THE/DC ; PHI/DA ; PSI/DP	-.00747	(.0279)	(.0644)	(.0794)	(.122)	(.417)	(.435)	(4.01)	(5.75)	(8.52)	<-.462E-5>		
PSI/DC ; PHI/DA ; THE/DB	-.0220	(.0157)	(.0644)	(.0699)	(.131)	(.541)	(.588)	(1.76)	(2.59)	(5.75)	<-.170E-5>		
XD/DB ; PHI/DA ; PSI/DP	-.493	(.0644)	(.0699)	(.0794)	(.122)	(1.20)	(2.59)	(4.01)	(5.75)	[.0143; 2.36]	<-.00862>		
YD/DA ; THE/DB ; PSI/DP	.155	(.0178)	(.0644)	(.0699)	(.0794)	(1.19)	(2.59)	(4.01)	(5.75)	[-.0037; 4.30]	<.00130>		
ZD/DC ; PHI/DA ; THE/DB	1.37	(0)	(.0152)	(.0644)	(.0699)	(2.59)	(5.75)	[.717; .309]	[.634; 2.95]	<.00116>			
ZD/DC ; PHI/DA ; PSI/DP	9.41	(.0644)	(.0794)	(.127)	(.133)	(.995)	(2.45)	(4.01)	(5.75)	[.722; .257]	<.00302>		
XD/DC ; PHI/DA ; THE/DB	-.0380	(0)	(.0644)	(.0699)	(1.14)	(2.59)	(5.75)	[.729; .345]	[.609; 2.98]	<-.00307>			
XD/DC ; PHI/DA ; PSI/DP	-.211	(.0644)	(.0794)	(.122)	(.357)	(.509)	(-1.07)	(4.01)	(5.75)	[.705; 2.99]	<.00527>		
YD/DP ; PHI/DA ; THE/DB	-.0951	(.0179)	(.0644)	(.0699)	(.0794)	(1.18)	(2.59)	(4.01)	(4.21)	(-4.48)	(5.75)	<.000808>	
ZD/DB ; PHI/DA ; PSI/DP	-2.96	(.0340)	(.0644)	(.0699)	(.0794)	(.122)	(2.59)	(4.01)	(5.75)	[.0963; 2.42]	<-.00154>		
ZD/DC ; PHI/DA ; THE/DB ; PSI/DP	-1.49	(.0154)	(.0644)	(.0699)	(.0794)	(.123)	(2.59)	(4.01)	(5.75)	<-.598E-4>			
XD/DC ; PHI/DA ; THE/DB ; PSI/DP	.0413	(.0644)	(.0699)	(.0794)	(.120)	(1.12)	(2.59)	(4.01)	(5.75)	<.000118>			

TABLE IV-5 CONTINUED
AH-IG TRANSFER FUNCTION FACTORS

CASE 66 I20KT SCAS OFF

DENOMINATOR: (0) (.0461) (1.17) [.0699; .196] [.472; 1.45] [.378; 1.69] <.0125>

CONTROL NUMERATORS:

PHI/DA .491 (0) [.0792; .228] [.518; 1.43] [.429; 1.76] <.160>
THE/DB -.175 (0) (.0249) (.0454) (.917) (1.36) [.394; 1.72] <-.000735>
PSI/DP -1.12 (-.181) (.455) (1.13) [.0994; .201] [.429; 1.40] <.00831>

PHI/DB .0944 (0) (-.0440) (.0859) [.407; 1.80] [.400; 2.79] <-.00902>
THE/DA .0710 (0) (.0400) (-.0669) (1.34) [.473; 1.62] <-.000672>

PHI/DA ; THE/DB -.0860 (0) (.0266) (1.37) [.425; 1.77] <-.00989>
PHI/DA ; PSI/DP -.564 (.143) [.0765; .231] [.522; 1.40] <-.00838>
THE/DB ; PSI/DP .196 (.0274) (-.178) (1.36) [.966; .643] <-.000537>

PHI/DB ; PSI/DP -.122 (-.0636) (.0949) (.156) [.371; 2.69] <.000830>
PHI/DP ; THE/DB -.0797 (0) (.0273) (1.65) [.445; 1.04] <-.00385>
PHI/DC ; THE/DB .0166 (0) (.0256) (-2.94) [.639; 1.82] <-.00415>

THE/DA ; PSI/DP -.0778 (.0639) (-.225) (.254) (1.37) <.000389>
THE/DP ; PHI/DA .00997 (0) (.0685) (.468) (-2.49) (2.99) <-.00238>
THE/DC ; PHI/DA .0752 (0) (.0374) [-.530; 1.79] <.00904>

PSI/DA ; THE/DB -.00502 (.0267) (-1.04) (1.36) (1.64) (-4.74) <-.00147>
PSI/DB ; PHI/DA .0150 (.111) (-.285) (.442) [.188; 2.13] <-.000952>
XD/DB ; PHI/DA .330 (0) (1.68) [.424; 1.78] [-.00639; 2.61] <11.9>

YD/DA ; THE/DB -.149 (.0267) (1.37) [.301; 1.63] [.0598; 4.53] <-.299>
ZD/DB ; PHI/DA 3.41 (0) (.0462) [.427; 1.78] [.0957; 2.63] <3.46>
XD/DC ; PHI/DA .476 (0) (-1.33) [.552; 1.70] [.253; 2.04] <-7.63>

YD/DP ; THE/DB -.356 (.0274) (-.633) (-2.80) (2.86) [.909; 1.49] <-.109>
ZD/DC ; PHI/DA -9.17 (0) (.100) [.0461; 1.32] [.496; 1.73] <-4.77>

PHI/DA ; THE/DB ; PSI/DP .0986 (.0262) (.143) (1.36) <.000503>
PHI/DC ; THE/DB ; PSI/DP .0106 (.0252) (.145) (7.29) <.000283>
THE/DC ; PHI/DA ; PSI/DP -.0822 (.0353) (.143) <-.000416>

PSI/DC ; PHI/DA ; THE/DB -.0319 (.0246) (.152) (1.53) <-.000184>
XD/DB ; PHI/DA ; PSI/DP -.378 (.144) (1.68) [-.00571; 2.60] <-.616>
YD/DA ; THE/DB ; PSI/DP .177 (.0261) (1.36) [-.00621; 4.36] <.119>

ZD/DC ; PHI/DA ; THE/DB 1.65 (0) (.0213) [.437; 1.67] <.0987>
ZD/DC ; PHI/DA ; PSI/DP 10.6 (.110) (.143) [.139; 1.23] <.251>
XD/DC ; PHI/DA ; THE/DB -.0793 (0) (.815) [.357; 1.77] <-.202>

XD/DC ; PHI/DA ; PSI/DP -.527 (.143) (-1.30) [.376; 1.94] <.371>
YD/DP ; PHI/DA ; THE/DB -.107 (.0262) (1.34) (5.07) (-5.37) <.102>
ZD/DB ; PHI/DA ; PSI/DP -3.91 (.0468) (.144) [.0931; 2.62] <-.182>

ZD/DC ; PHI/DA ; THE/DB ; PSI/DP -1.87 (.0223) (.144) <-.00604>
XD/DC ; PHI/DA ; THE/DB ; PSI/DP .0898 (.141) (.659) <.00833>

TABLE IV-5 CONTINUED
AH-IG TRANSFER FUNCTION FACTORS

CASE 66 I20KT SCAS ON

ENOMINATOR: (0) (-.270) (.650) [-.537; .0258] [.0854; .110] [.755; .331] [.893; 2.59] [.757; 3.10] [.621; 3.23] <-.000146>

ONTROL NUMERATORS:

PHI/DA .491 (0) (.0644) (.270) (.651) (5.75) [.0756; .131] [.750; .330] [.880; 2.50] [.649; 3.08] <-.00352>
THE/DB -.175 (0) (.0251) (.0699) (1.36) (2.59) [.584; .0259] [.755; .331] [.754; 3.19] [.620; 3.25] <-.853E-5>
PSI/DP -1.12 (.0794) (-.0972) (.270) (.650) (4.01) [-.0950; .128] [.862; .157] [.892; 2.57] [.749; 3.30] <-.000177>

PHI/DB .0944 (0) (-.0452) (.0699) (.0859) (.373) (1.00) (2.59) [.752; .128] [.383; 2.65] [.652; 3.29] <-.000203>
THE/DA .0736 (0) (-.0352) (-.0598) (.0644) (1.36) (5.75) [-.737; .255] [.998; .438] [.649; 2.90] <-.822E-5>

PHI/DA ;THE/DB -.0860 (0) (.0266) (-.0644) (.0699) (1.36) (2.59) (5.75) [.750; .329] [.646; 3.10] <-.000218>
PHI/DA ;PSI/DP -.564 (.0644) (.0794) (.143) (.270) (.651) (4.01) (5.75) [.0727; .132] [.880; 2.48] <-.000179>
THE/DB ;PSI/DP .196 (-.0274) (-.0699) (.0794) (-.0963) (1.36) (2.59) (4.01) [-.867; .156] [.745; 3.40] <-.115E-4>

PHI/DB ;PSI/DP -.122 (-.0636) (.0699) (.0794) (-.0949) (.156) (.370) (1.00) (2.59) (4.01) [.371; 2.69] <-.177E-4>
THE/DP ;THE/DB -.0797 (0) (.0273) (.0699) (.0794) (1.45) (2.59) (4.01) [.811; .382] [.678; 1.76] <-.822E-4>
PHI/DC ;THE/DB .0166 (0) (-.0256) (-.0699) (.363) (1.02) (2.59) (-4.38) [-.741; .321] [-.777; 2.68] <-.924E-4>

THE/DA ;PSI/DP -.0778 (.0639) (.0644) (.0794) (-.225) (.254) (.417) (.435) (1.37) (4.01) (5.75) <-.829E-5>
THE/DP ;PHI/DA .00997 (0) (.0643) (-.0644) (.0794) (.643) (2.21) (4.01) (-5.46) (5.75) [.936; .305] <-.546E-4>
THE/DC ;PHI/DA .0911 (0) (-.0373) (-.0644) (5.75) [-.759; .329] [1.00; .426] [-.696; 2.84] <-.000200>

PSI/DA ;THE/DB -.00502 (.0267) (.0644) (.0699) (.541) (.588) (-1.04) (1.36) (1.64) (2.59) (-4.74) (5.75) <-.314E-4>
PSI/DB ;PHI/DA .0150 (.0644) (.0699) (.111) (-.269) (-.848) (2.59) (5.75) [.924; .383] [-.224; 2.34] <-.203E-4>
XD/DB ;PHI/DA .330 (0) (.0644) (.0699) (1.68) (2.59) (5.75) [-.751; .329] [-.00579; 2.61] [.644; 3.10] <-.262>

YD/DA ;THE/DB -.149 (.0267) (.0644) (.0699) (1.36) (2.59) (5.75) [-.590; .313] [-.587; 3.08] [.0685; 4.34] <-.00637>
ZD/DB ;PHI/DA 3.41 (0) (.0462) (.0644) (.0699) (2.59) (5.75) [-.752; .329] [-.0944; 2.62] [-.646; 3.11] <-.0763>
XD/DC ;PHI/DA .476 (0) (.0644) (.369) (.480) (-.757) (5.75) [-.758; .335] [-.770; 2.59] [-.567; 3.09] <-.170>

YD/DP ;THE/DB -.356 (-.0274) (.0699) (.0794) (-.119) (-.163) (1.33) (2.59) (3.17) (-3.70) (4.01) [-.627; 3.69] <-.00232>
ZD/DC ;PHI/DA -9.17 (0) (.0644) (-.112) (1.06) (2.82) (5.75) [-.854; .294] [-.650; .348] [-.664; 2.98] <-.105>

PHI/DA ;THE/DB ;PSI/DP .0986 (.0262) (.0644) (.0699) (.0794) (.143) (1.36) (2.59) (4.01) (5.75) <-.107E-4>
PHI/DC ;THE/DB ;PSI/DP .0106 (.0252) (.0699) (.0794) (-.145) (-.370) (1.00) (2.59) (4.01) (7.29) <-.603E-5>
THE/DC ;PHI/DA ;PSI/DP -.0822 (-.0353) (.0644) (.0794) (-.143) (-.417) (-.435) (4.01) (5.75) <-.887E-5>

PSI/DC ;PHI/DA ;THE/DB -.0319 (.0246) (.0644) (.0699) (-.152) (-.541) (.588) (1.53) (2.59) (5.75) <-.392E-5>
XD/DB ;PHI/DA ;PSI/DP -.378 (.0644) (-.0699) (.0794) (.144) (1.68) (2.59) (4.01) (5.75) [-.00571; 2.60] <-.0131>
YD/DA ;THE/DB ;PSI/DP .177 (.0261) (.0644) (.0699) (.0794) (1.36) (2.59) (4.01) (5.75) [-.00621; 4.36] <-.00255>

ZD/DC ;PHI/DA ;THE/DB 1.65 (0) (-.0214) (.0644) (.0699) (2.59) (5.75) [-.745; .316] [-.650; 3.05] <-.00219>
ZD/DC ;PHI/DA ;PSI/DP 10.6 (.0644) (.0794) (.133) (.133) (1.05) (2.68) (4.01) (5.75) [-.764; .289] <-.00535>
XD/DC ;PHI/DA ;THE/DB -.0793 (0) (.0644) (.0699) (.662) (2.59) (5.75) [-.739; .366] [-.627; 3.06] <-.00441>

XD/DC ;PHI/DA ;PSI/DP -.527 (.0644) (.0794) (.143) (.370) (.480) (-.730) (4.01) (5.75) [-.721; 2.62] <-.00791>
YD/DP ;PHI/DA ;THE/DB -.107 (.0262) (.0644) (.0699) (.0794) (1.34) (2.59) (4.01) (5.07) (-5.37) (5.75) <-.00217>
ZD/DB ;PHI/DA ;PSI/DP -3.91 (.0468) (.0644) (.0699) (.0794) (.144) (2.59) (4.01) (5.75) [-.0931; 2.62] <-.00387>

ZD/DC ;PHI/DA ;THE/DB ;PSI/DP -1.87 (.0223) (.0644) (.0699) (.0794) (.144) (2.59) (4.01) (5.75) <-.000129>
XD/DC ;PHI/DA ;THE/DB ;PSI/DP .0898 (.0644) (.0699) (.0794) (.141) (.659) (2.59) (4.01) (5.75) <-.000178>

TABLE IV-5 CONTINUED
AH-IG TRANSFER FUNCTION FACTORS

CASE 67 140KT SCAS OFF

DENOMINATOR: (0) (.0924) (-.848) [-.0381; .183] [.515; 1.54] [.346; 1.91] <.0229>

CONTROL NUMERATORS:

PHI/DA .503 (0) [.106; .210] [.505; 1.53] [.421; 2.02] <.212>
THE/DB -.199 (0) (.0385) (.102) (.590) (1.50) [.431; 1.81] <-.00227>
PSI/DP -1.15 (-.0854) (.385) (.806) [-.112; -.155] [.405; 1.64] <.00198>

PHI/DB .132 (0) [.541; .0518] [.544; 1.75] [.295; 3.06] <.0102>
THE/DA .0603 (0) (.0473) (-.129) (1.81) [.577; 1.50] <-.00151>

PHI/DA ; THE/DB -.0998 (0) (.0381) (1.44) [.473; 1.93] <-.0204>
PHI/DA ; PSI/DP -.592 (.163) [.107; .210] [.459; 1.67] <-.0118>
THE/DB ; PSI/DP .232 (.0364) (-.0616) (1.57) [.956; .441] <-.000159>

PHI/DB ; PSI/DP -.131 (.165) [.577; .0467] [.420; 3.09] <-.000453>
PHI/DP ; THE/DB -.0969 (0) (.0367) (2.10) [.621; .548] <-.00224>
PHI/DC ; THE/DB .0424 (0) (.0386) (-1.97) [.772; 1.72] <-.00958>

THE/DA ; PSI/DP -.0635 (.0637) (-.305) (.321) (1.80) <.000712>
THE/DP ; PHI/DA .0179 (0) (.0665) (.507) (-2.27) (3.63) <-.00500>
THE/DC ; PHI/DA -.0226 (0) (.0483) (-4.61) [.655; 1.81] <.0165>

PSI/DA ; THE/DB -.00549 (.0381) (-.728) (1.28) (1.78) (-7.43) <-.00257>
PSI/DB ; PHI/DA -.0266 (.119) [-.136; .204] [-.135; 2.68] <-.000941>
XD/DB ; PHI/DA .136 (0) (3.73) [-.490; 1.88] [-.0426; 3.08] <17.0>

YD/DA ; THE/DB -.175 (.0381) (1.45) [.294; 1.71] [.0897; 4.63] <-.607>
ZD/DB ; PHI/DA 4.24 (0) (.0609) [.465; 1.86] [.0827; 2.91] <7.61>
XD/DC ; PHI/DA .898 (0) (-.935) [.580; 1.70] [.208; 2.08] <-10.6>

YD/DP ; THE/DB -.421 (.0363) (-.161) (-3.60) (3.92) [.940; 1.04] <-.0375>
ZD/DC ; PHI/DA -9.86 (0) (.104) [-.0193; 1.50] [.562; 1.87] <-8.09>

PHI/DA ; THE/DB ; PSI/DP .119 (.0378) (.163) (1.52) <.00111>
PHI/DC ; THE/DB ; PSI/DP .0915 (.0381) (.164) <.000570>
THE/DC ; PHI/DA ; PSI/DP .0162 (.0465) (.163) (-6.48) <-.000792>

PSI/DC ; PHI/DA ; THE/DB -.0598 (.0368) (.172) (1.14) <-.000432>
XD/DB ; PHI/DA ; PSI/DP -.164 (.163) (3.65) [-.0417; 3.09] <-.936>
YD/DA ; THE/DB ; PSI/DP .215 (.0377) (1.51) [-.0113; 4.45] <.242>

ZD/DC ; PHI/DA ; THE/DB 2.15 (0) (.0302) [-.488; 1.69] <.185>
ZD/DC ; PHI/DA ; PSI/DP 11.7 (.116) (.162) [.131; 1.41] <.443>
XD/DC ; PHI/DA ; THE/DB -.172 (0) (.561) [.402; 1.79] <-.307>

XD/DC ; PHI/DA ; PSI/DP -1.02 (.162) (-.871) [.314; 1.91] <.526>
YD/DP ; PHI/DA ; THE/DB -.126 (.0378) (1.49) (5.91) (-6.25) <.262>
ZD/DB ; PHI/DA ; PSI/DP -5.01 (.0614) (.164) [.0869; 2.90] <-.422>

ZD/DC ; PHI/DA ; THE/DB ; PSI/DP -2.49 (.0326) (.164) <-.0134>
XD/DC ; PHI/DA ; THE/DB ; PSI/DP .199 (.159) (.422) <.0134>

TABLE IV-5 CONTINUED
AH-IG TRANSFER FUNCTION FACTORS

CASE 69 60KT MAX CLIMB SCAS OFF

DENOMINATOR: (0) (.637) (1.01) [-.313; .139] [.0516; .964] [.413; 1.17] <-.0159>

CONTROL NUMERATORS:

PHI/DA .600 (0) [-.0879; .168] [.435; 1.10] [.491; 1.29] <.0344>
THE/DB -.184 (0) (.0126) (.487) [-.0183; .883] [.997; 1.04] <-.000955>
PSI/DP -.903 (1.19) [.138; .0584] [-.417; .458] [.409; 1.25] <-.00120>

PHI/DB .0880 (0) (-.357) (1.20) [-.608; .664] [.527; 2.11] <-.0738>
THE/DA .0848 (0) (-.00990) (.0571) (1.32) [.397; 1.04] <-.684E-4>

PHI/DA ; THE/DB -.110 (0) (.0163) (.977) [-.508; 1.17] <-.00239>
PHI/DA ; PSI/DP -.556 (.0655) [-.0395; .138] [.447; 1.21] <-.00102>
THE/DB ; PSI/DP .167 (.0192) (.945) (1.21) [-.435; .465] <-.000794>

PHI/DB ; PSI/DP -.0643 (.0661) (-.296) (.372) [.855; 2.10] <.00207>
PHI/DP ; THE/DB -.0832 (0) (.0194) (-.817) (.992) (1.62) <.00226>
PHI/DC ; THE/DB -.0163 (0) (.00285) (.942) [.675; 3.81] <-.000639>

THE/DA ; PSI/DP -.0714 (.0196) (1.35) [-.347; .412] <-.000321>
THE/DP ; PHI/DA .0136 (0) (.0198) (1.72) [-.0194; 1.45] <.000980>
THE/DC ; PHI/DA -.0145 (0) (.0276) (-8.15) [.526; 1.03] <.00344>

PSI/DA ; THE/DB .0616 (.0164) (-.546) (.891) (1.60) <-.000789>
PSI/DB ; PHI/DA -.0221 (.0619) [.00347; .480] [-.0649; 2.32] <-.00170>
XD/DB ; PHI/DA .866 (0) (.741) [.504; 1.16] [.0463; 2.34] <4.75>

YD/DA ; THE/DB -.192 (.0165) (.980) [.437; 1.09] [.0441; 4.46] <-.0737>
YD/DB ; PHI/DA 1.68 (0) (-.0162) [.485; 1.14] [.0600; 2.54] <-.229>
XD/DC ; PHI/DA -.0644 (0) (.611) [-.515; 1.02] [-.500; 3.19] <-4.16>

YD/DP ; THE/DB -.361 (.0191) (.993) (-.999) (1.67) [-.0363; 2.55] <.0742>
ZD/DC ; PHI/DA -9.03 (0) (.0281) [.511; 1.05] [-.0557; 1.08] <-.330>

PHI/DA ; THE/DB ; PSI/DP .102 (.0176) (.0643) (1.03) <.000119>
PHI/DC ; THE/DB ; PSI/DP .0901 (0) (.0614) (1.17) <.00649>
THE/DC ; PHI/DA ; PSI/DP -.114 (.0236) (.0659) <-.000177>

PSI/DC ; PHI/DA ; THE/DB -.0934 (.00267) (.0699) (.755) <-.1313-4>
XD/DB ; PHI/DA ; PSI/DP -.805 (.0642) (.782) [-.0466; 2.34] <-.221>
YD/DA ; THE/DB ; PSI/DP .185 (.0176) (1.03) [-.0186; 4.37] <.0640>

ZD/DC ; PHI/DA ; THE/DB 1.69 (0) (.0275) [.483; .992] <.0458>
ZD/DC ; PHI/DA ; PSI/DP 8.40 (.0259) (.0659) [.106; 1.12] <.0181>
XD/DC ; PHI/DA ; THE/DB .0327 (0) (-4.44) [.578; 1.13] <-.187>

XD/DC ; PHI/DA ; PSI/DP .112 (.0659) (3.53) [-.416; 3.09] <.248>
YD/DP ; PHI/DA ; THE/DB -.124 (.0176) (1.00) (2.14) (-2.39) <.3111>
ZD/DB ; PHI/DA ; PSI/DP -1.56 (-.00217) (.0648) [.0622; 2.53] <.00140>

ZD/DC ; PHI/DA ; THE/DB ; PSI/DP -1.55 (.0230) (.0660) <-.00236>
XD/DC ; PHI/DA ; THE/DB ; PSI/DP -.0234 (.0648) (-6.23) <.00944>

TABLE IV-5 CONTINUED
AH-IG TRANSFER FUNCTION FACTORS

CASE 69 60KT MAX CLIMB SCAS ON

DENOMINATOR: (0) (-.268) (.631) [-.0190; .0307] [.657; .188] [.196; .193] [.921; 2.19] [.638; 3.07] [.753; 3.14] <-.925E-4>

CONTROL NUMERATORS:

PHI/DA .600 (0) (.0644) (.267) (.632) (5.75) [-.0749; .0748] [.641; .251] [.923; 2.19] [.657; 2.69] <.000730>
THE/DB -.184 (0) (.0139) (.0699) (1.03) (2.59) [-.675; .131] [-.355; .205] [.689; 2.97] [.688; 3.20] <-.309E-4>
PSI/DP -.903 (.0794) (.173) (.265) (.632) (4.01) [-.231; .0340] [-.295; .201] [.933; 2.23] [.758; 3.64] <-.256E-4>

PHI/DB .0880 (0) (.0699) (-.338) (1.05) (2.59) [-.535; .295] [-.996; .388] [.910; 1.65] [.460; 2.91] <-.00160>
THE/DA .0856 (0) (.0132) (.0644) (.0303) (1.35) (5.75) [-.999; .429] [-.124; .482] [.619; 2.39] <.111E-4>

PHI/DA ; THE/DB -.110 (0) (.0163) (.0644) (.0699) (1.03) (2.59) (5.75) [-.623; .246] [.654; 2.65] <-.525E-4>
PHI/DA ; PSI/DP -.556 (.0644) (.0653) (.0794) (.265) (.632) (4.01) (5.75) [-.0168; .0783] [.932; 2.22] <-.217E-4>
THE/DB ; PSI/DP .167 (.0192) (.0699) (.0794) (.182) (1.03) (2.59) (4.01) [-.305; .192] [.751; 3.63] <.169E-4>

PHI/DB ; PSI/DP -.0643 (.0661) (.0699) (.0794) (-.296) (.370) (.372) (1.00) (2.59) (4.01) [.855; 2.10] <.442E-4>
PHI/DP ; THE/DB -.0892 (0) (.0195) (.0699) (.0794) (.483) (.594) (-.900) (1.03) (1.64) (2.59) (4.01) <.481E-4>
PHI/DC ; THE/DB -.180 (0) (.00285) (.0699) (.372) (2.59) (4.27) [.652; .291] [.999; 1.05] <-.139E-4>

THE/DA ; PSI/DP -.0714 (.0196) (.0644) (.0794) (.417) (.435) (1.35) (4.01) (5.75) [-.347; .412] <-.684E-5>
THE/DP ; PHI/DA .0136 (0) (.0199) (.0644) (.0794) (.326) (.566) (-.839) (1.37) (-2.91) (4.01) (5.75) <.197E-4>
THE/DC ; PHI/DA .180 (0) (.0273) (.0644) (5.75) [-.609; .220] [1.00; .427] [.679; 2.18] <.759E-4>

PSI/DA ; THE/DB -.0616 (.0164) (.0644) (.0699) (.541) (-.546) (-.588) (.891) (1.60) (2.59) (5.75) <-.168E-4>
PSI/DB ; PHI/DA -.0221 (.0619) (.0644) (.0699) (2.59) (5.75) [-.0597; .512] [.974; .573] [-.136; 2.14] <-.362E-4>
XD/DB ; PHI/DA .866 (0) (.0644) (.0699) (.781) (2.59) (5.75) [-.623; .245] [.0464; 2.34] [.655; 2.64] <.104>

XD/DA ; THE/DB -.192 (.0165) (.0644) (.0699) (1.02) (2.59) (5.75) [-.515; .232] [.624; 2.69] [.0467; 4.33] <-.00157>
XD/DB ; PHI/DA 1.68 (0) (-.0155) (.0644) (.0699) (2.59) (5.75) [-.633; .251] [.0624; 2.54] [.650; 2.62] <-.00491>
XD/DC ; PHI/DA -1.40 (0) (.0644) (.327) (.581) (5.75) [-.606; .225] [-.710; 1.89] [.691; 2.29] <-.0937>

XD/DP ; THE/DB -.361 (.0191) (.0699) (.0794) (1.01) (-1.61) (1.98) (2.59) (4.01) [.489; .311] [.423; 3.58] <.00158>
XD/DC ; PHI/DA -9.03 (0) (.0269) (.0644) (1.03) (2.93) (5.75) [-.634; .222] [.818; .288] [.644; 2.50] <-.00692>

PHI/DA ; THE/DB ; PSI/DP .102 (.0176) (.0643) (.0644) (.0699) (.0794) (1.03) (2.59) (4.01) (5.75) <.254E-5>
PHI/DC ; THE/DB ; PSI/DP .0902 (.00298) (.0614) (.0699) (.0794) (.370) (1.00) (1.17) (2.59) (4.01) <.413E-6>
THE/DC ; PHI/DA ; PSI/DP -.114 (.0236) (.0644) (.0659) (.0794) (.417) (.435) (4.01) (5.75) <-.378E-5>

PSI/DC ; PHI/DA ; THE/DB -.0934 (.00267) (.0644) (.0698) (.0699) (.541) (-.588) (-.755) (2.59) (5.75) <-.280E-6>
XD/DB ; PHI/DA ; PSI/DP -.805 (.0642) (.0644) (.0699) (.0794) (.782) (2.59) (4.01) (5.75) [-.0466; 2.34] <-.00471>
XD/DA ; THE/DB ; PSI/DP .185 (.0176) (.0644) (.0699) (.0794) (1.03) (2.59) (4.01) (5.75) [-.0186; 4.37] <.00136>

ZD/DC ; PHI/DA ; THE/DB 1.69 (0) (.0274) (.0644) (.0699) (2.59) (5.75) [-.599; .222] [.646; 2.56] <.00101>
ZD/DC ; PHI/DA ; PSI/DP 8.40 (.0261) (.0644) (.0659) (.0794) (1.03) (2.71) (4.01) (5.75) [.831; .284] <.000386>
XD/DC ; PHI/DA ; THE/DB .0327 (0) (.0644) (.0699) (2.59) (-4.80) (5.75) [-.619; .238] [.699; 2.62] <-.00411>

XD/DC ; PHI/DA ; PSI/DP .112 (.0644) (.0658) (.0794) (.327) (.580) (4.01) (5.75) (7.75) [-.811; 2.04] <.00529>
XD/DP ; PHI/DA ; THE/DB -.124 (.0176) (.0644) (.0699) (.0794) (1.00) (2.14) (-2.39) (2.59) (4.01) (5.75) <.000237>
ZD/DB ; PHI/DA ; PSI/DP -1.56 (-.00217) (.0644) (.0648) (.0699) (.0794) (2.59) (4.01) (5.75) [-.0622; 2.53] <.299E-4>

ZD/DC ; PHI/DA ; THE/DB ; PSI/DP -1.55 (.0230) (.0644) (.0660) (.0699) (.0794) (2.59) (4.01) (5.75) <-.503E-4>
XD/DC ; PHI/DA ; THE/DB ; PSI/DP -.0234 (.0644) (.0648) (.0699) (.0794) (2.59) (4.01) (5.75) (-6.23) <.000201>

TABLE IV-5 CONTINUED
AH-IG TRANSFER FUNCTION FACTORS

CASE 71 60 KT AUTOROTATION SCAS OFF

DENOMINATOR: (0) (-.185) (.855) [.0506;.265] [.368;1.20] [.961;1.24] <-.0247>

CONTROL NUMERATORS:

PHI/DA .443 (0) [.0756;.276] [.672;.923] [.378;1.20] <.0414>
THE/DB -.148 (0) (-.00809) (-.162) (.812) (1.81) [.479;1.20] <-.000413>
PSI/DP -.980 (-.564) (.581) (1.94) [.0833;.272] [.621;.933] <.0401>

PHI/DB .0117 (0) (-1.17) (9.32) [-.304;.237] [.282;1.81] <-.0236>
THE/DA .0804 (0) (-.0351) (.0393) (.810) [.380;1.20] <-.000130>

PHI/DA ; THE/DB -.0657 (0) (-.00946) (.878) [.396;1.22] <.000816>
PHI/DA ; PSI/DP -.446 (.135) [.0763;.279] [.643;.888] <-.00368>
THE/DB ; PSI/DP .145 (-.00899) (-.572) (.614) (.892) (1.85) <.000756>

PHI/DB ; PSI/DP -.0455 (.102) (.244) (-.335) [.579;1.83] <.00127>
PHI/DP ; THE/DB -.0564 (0) (-.00902) (.867) [.251;2.30] <.00233>
PHI/DC ; THE/DB -.0224 (0) (.0194) (-.572) [.586;1.86] <.000863>

THE/DA ; PSI/DP -.0800 (.0494) (-.126) (.157) (.801) <.625E-4>
THE/DP ; PHI/DA .00232 (0) (.0557) (.227) (1.10) (-5.14) <-.000166>
THE/DC ; PHI/DA .0330 (0) (.0139) (1.81) [-.401;1.26] <.00131>

PSI/DA ; THE/DB -.00440 (-.00950) (.752) (1.61) [-.0984;2.23] <.000252>
PSI/DB ; PHI/DA .0392 (.151) [-.0701;.122] [-.112;1.78] <.000278>
XD/DB ; PHI/DA .476 (0) (.723) [-.396;1.23] [-.00216;2.31] <2.78>

YD/DA ; THE/DB -.112 (-.00949) (.893) [-.328;1.22] [.00128;4.14] <.0242>
ZD/DB ; PHI/DA 1.22 (0) (-.0357) [-.410;1.24] [.127;2.07] <-.288>
XD/DC ; PHI/DA .353 (0) (1.43) (-3.76) [.390;1.26] <-3.02>

YD/DP ; THE/DB -.260 (-.00899) (.870) [-.704;2.03] [.727;2.95] <.0729>
ZD/DC ; PHI/DA -6.50 (0) (.0548) [-.164;1.01] [-.446;1.19] <-.511>

PHI/DA ; THE/DB ; PSI/DP .0660 (-.00930) (.135) (.864) <-.715E-4>
PHI/DC ; THE/DB ; PSI/DP .0208 (-.0233) (.151) (1.52) <-.000112>
THE/DC ; PHI/DA ; PSI/DP -.0330 (.0135) (.135) (1.87) <-.000113>

PSI/DC ; PHI/DA ; THE/DB -.0200 (-.00439) (.143) <.126E-4>
XD/DB ; PHI/DA ; PSI/DP -.479 (.135) (.720) [-.00354;2.31] <-.248>
YD/DA ; THE/DB ; PSI/DP .117 (-.00935) (.865) [-.000826;4.02] <-.0153>

ZD/DC ; PHI/DA ; THE/DB .872 (0) (0) [-.407;1.21] <1.28>
ZD/DC ; PHI/DA ; PSI/DP 6.54 (.0572) (.135) [.198;.966] <.0470>
XD/DC ; PHI/DA ; THE/DB -.0378 (0) (2.53) [.378;1.24] <-.148>

XD/DC ; PHI/DA ; PSI/DP -.346 (.135) (1.52) (-3.76) <.266>
YD/DP ; PHI/DA ; THE/DB -.0724 (-.00929) (.863) (3.40) (-3.49) <-.00689>
ZD/DB ; PHI/DA ; PSI/DP -1.23 (-.0361) (.135) [-.124;2.09] <.0260>

ZD/DC ; PHI/DA ; THE/DB ; PSI/DP -.875 (0) (.135) <-.118>
XD/DC ; PHI/DA ; THE/DB ; PSI/DP .0379 (.135) (2.50) <.0127>

TABLE IV-5 CONTINUED
AH-IG TRANSFER FUNCTION FACTORS

CASE 71 60KT AUTOROTATION SCAS ON

DENOMINATOR: (0) (.0644) (-.193) (.263) (.640) (1.48) (2.13) [-.00162; .143] [.814; .305] [.626; 2.67] [.826; 3.44] [-.00106]

CONTROL NUMERATORS:

PHI/DA .443 (0) (.0644) (.263) (.640) (1.47) (2.22) (5.75) [-.00738; .143] [.706; .265] [.624; 2.68] <.000932>
THE/DB -.148 (0) (-.00859) (.0650) (.0699) (-.190) (.865) (2.59) [-.813; .305] [.627; 2.72] [.829; 3.34] <-.184E-4>
PSI/DP -.980 (.0794) (.263) (-.324) (.640) (1.48) (2.25) (4.01) [-.00454; .143] [.860; .258] [.848; 3.36] <.000855>

PHI/DB .146 (0) (.0699) (-.692) (2.59) [.393; .189] [.994; .359] [.966; 1.10] [.449; 2.26] <-.000521>
THE/DA .0807 (0) (.0406) (-.0486) (.0644) (.413) (.434) (.801) (5.75) [.692; .243] [.622; 2.68] <-.364E-5>

PHI/DA ; THE/DB -.0657 (0) (-.00945) (.0644) (.0699) (.865) (2.59) (5.75) [-.706; .264] [.622; 2.70] <.184E-4>
PHI/DA ; PSI/DP -.446 (.0644) (.0794) (.135) (.263) (.640) (1.48) (2.16) (4.01) (5.75) [-.00752; .143] <-.786E-4>
THE/DB ; PSI/DP .145 (-.00899) (-.0699) (.0794) (-.324) (.865) (2.59) (4.01) [.860; .257] [.839; 3.40] <.161E-4>

PHI/DB ; PSI/DP -.0455 (.0699) (.0794) (.102) (.244) (-.335) (.370) (1.00) (2.59) (4.01) [.579; 1.83] <.271E-4>
PHI/DP ; THE/DB -.0564 (0) (-.00902) (.0699) (.3794) (.434) (.699) (.862) (2.59) (4.01) [-.361; 2.55] <.498E-4>
PHI/DC ; THE/DB -.0224 (0) (.0207) (.0699) (-.257) (.303) (.344) (2.59) [.979; 1.03] [.562; 2.87] <.199E-4>

THE/DA ; PSI/DP -.0800 (.0494) (.0644) (.0794) (-.126) (.157) (.417) (.435) (.801) (4.01) (5.75) <.133E-5>
THE/DP ; PHI/DA .00232 (0) (.0547) (.0644) (.0794) (.227) (.369) (.479) (1.10) (4.01) (-5.37) (5.75) <-.352E-5>
THE/DC ; PHI/DA .0330 (0) (.0138) (.0644) (.417) (.435) (1.85) (5.75) [.708; .265] [.613; 2.73] <.295E-4>

PSI/DA ; THE/DB -.00440 (-.00950) (.0644) (.0699) (.541) (.588) (.752) (1.61) (2.59) (5.75) [-.0984; 2.23] <.537E-5>
PSI/DB ; PHI/DA .0392 (.0644) (.0699) (.151) (.537) (.591) (2.59) (5.75) [-.0703; .122] [-.112; 1.78] <.594E-5>
XD/DB ; PHI/DA .476 (0) (.0644) (.0699) (.720) (2.59) (5.75) [-.706; .264] [-.00287; 2.31] [.621; 2.71] <.0626>

YD/DA ; THE/DB -.112 (-.00949) (.0644) (.0699) (-.867) (2.59) (5.75) [.522; .261] [.606; 2.69] [.0156; 4.11] <.000517>
ZD/DB ; PHI/DA 1.22 (0) (-.0357) (.0644) (-.0699) (2.59) (5.75) [-.708; .264] [.121; 2.08] [.630; 2.71] <-.00649>
XD/DC ; PHI/DA .946 (0) (.0644) (.321) (.597) (-1.06) (1.86) (5.75) [-.707; .266] [.611; 2.70] <-.0680>

YD/DP ; THE/DB -.260 (-.00899) (.0699) (.0794) (.254) (.863) (1.78) (2.59) (4.01) [-.949; 1.40] [-.663; 3.89] <.00155>
ZD/DC ; PHI/DA -6.50 (0) (.0625) (.0644) (1.04) (2.07) (5.75) [-.822; .261] [.669; .270] [-.628; 2.68] <-.0115>

PHI/DA ; THE/DB ; PSI/DP .0660 (-.00930) (.0644) (.0699) (.0794) (.135) (.864) (2.59) (4.01) (5.75) <-.153E-5>
PHI/DC ; THE/DB ; PSI/DP .0208 (-.0233) (.0699) (.0794) (.151) (-.370) (1.00) (1.52) (2.59) (4.01) <-.238E-5>
THE/DC ; PHI/DA ; PSI/DP -.0330 (-.0135) (.0644) (.0794) (.135) (.417) (.435) (1.87) (4.01) (5.75) <-.240E-5>

PSI/DC ; PHI/DA ; THE/DB -.0200 (-.00439) (.0644) (.0699) (.143) (.541) (.588) (2.59) (5.75) <.268E-6>
XD/DB ; PHI/DA ; PSI/DP -.479 (.0644) (.0699) (.0794) (.135) (.720) (2.59) (4.01) (5.75) [-.00354; 2.31] <-.00530>
YD/DA ; THE/DB ; PSI/DP .117 (-.00935) (.0644) (.0699) (.0794) (.865) (2.59) (4.01) (5.75) [-.000827; 4.02] <-.000327>

ZD/DC ; PHI/DA ; THE/DB .871 (0) (0) (.0644) (.0699) (2.59) (5.75) [.707; .260] [.624; 2.70] <.0287>
ZD/DC ; PHI/DA ; PSI/DP 6.54 (.0644) (.0665) (.0794) (.135) (1.04) (2.04) (4.01) (5.75) [.793; .262] <.00100>
XD/DC ; PHI/DA ; THE/DB -.0378 (0) (.0644) (.0699) (2.52) (2.59) (5.75) [-.706; .268] [.617; 2.69] <-.00332>

XD/DC ; PHI/DA ; PSI/DP -.936 (.0644) (.0794) (.135) (.321) (.597) (-1.06) (1.89) (4.01) (5.75) <.00567>
YD/DP ; PHI/DA ; THE/DB -.0724 (-.00929) (.0644) (.0699) (.0794) (.863) (2.59) (3.40) (-3.49) (4.01) (5.75) <-.000147>
ZD/DB ; PHI/DA ; PSI/DP -1.23 (-.0361) (.0644) (.0699) (.0794) (.135) (2.59) (4.01) (5.75) [-.124; 2.09] <.000555>

ZD/DC ; PHI/DA ; THE/DB ; PSI/DP -.875 (0) (.0644) (.0699) (.0794) (.135) (2.59) (4.01) (5.75) <-.00253>
XD/DC ; PHI/DA ; THE/DB ; PSI/DP .0379 (.0644) (.0699) (.0794) (.135) (2.50) (2.59) (4.01) (5.75) <.000272>

TABLE IV-5 CONTINUED
AH-IG TRANSFER FUNCTION FACTORS

CASE 77 60KT 20 FT/SEC CLIMB SCAS OFF

DENOMINATOR: (0) (-.286) (1.33) [-.199;.257] [.634;.886] [.181;1.08] <-.0229>

CONTROL NUMERATORS:

PHI/DA .524 (0) [-.172;.322] [.702;.858] [.456;1.17] <.0550>
THE/DB -.167 (0) (.00556) (.238) (.899) (1.26) [.204;1.05] <-.000276>
PSI/DP -.919 (1.34) [-.236;.304] [-.0369;.367] [.611;.848] <-.0110>

PHI/DB .0366 (0) (-.360) (.445) [.436;1.05] [.821;2.63] <-.0450>
THE/DA .0844 (0) (-.0204) (.0604) (.949) [.406;1.14] <-.000127>

PHI/DA ; THE/DB -.0875 (0) (.00821) (.915) [.455;1.18] <-.000913>
PHI/DA ; PSI/DP -.492 (.0678) [-.160;.315] [.707;.844] <-.00235>
THE/DB ; PSI/DP .154 (.00780) (.897) (1.27) [-.217;.396] <.000214>

PHI/DB ; PSI/DP -.0339 (.0690) (.307) (-.312) [.799;2.46] <.00136>
PHI/DP ; THE/DB -.0613 (0) (.00791) (-.873) (.992) (1.72) <.000647>
PHI/DC ; THE/DB -.00790 (0) (0) (1.05) [.531;3.84] <-.123>

THE/DA ; PSI/DP -.0757 (.00583) (.974) [-.0904;.294] <-.371E-4>
THE/DP ; PHI/DA .00821 (0) (.00673) (1.20) [-.0608;1.44] <.000137>
THE/DC ; PHI/DA .00723 (0) (.0303) (7.21) [.487;1.07] <.00179>

PSI/DA ; THE/DB -.00479 (.00827) (-.749) (.910) (1.39) (-7.60) <-.000285>
PSI/DB ; PHI/DA -.0174 (.0653) (1.74) [-.0471;.698] <-.000961>
XD/DB ; PHI/DA .678 (0) (.811) [.454;1.18] [.0291;2.17] <3.59>

YD/DA ; THE/DB -.152 (.00828) (.915) [.388;1.12] [.0351;4.40] <-.0283>
ZD/DB ; PHI/DA 1.57 (0) (-.00768) [.450;1.18] [.0690;2.25] <-.0856>
XD/DC ; PHI/DA -.0307 (0) (4.42) [.501;1.08] [-.261;3.52] <-1.95>

YD/DP ; THE/DB -.288 (.00778) (.891) (-1.25) (1.78) [.0514;2.19] <.0213>
ZD/DC ; PHI/DA -7.91 (0) (.160) [.0799;.772] [.457;1.06] <-.848>

PHI/DA ; THE/DB ; PSI/DP .0822 (.00810) (.0676) (.920) <.414E-4>
PHI/DC ; THE/DB ; PSI/DP .0425 (-.00172) (.0631) (1.23) <-.566E-5>
THE/DC ; PHI/DA ; PSI/DP -.0115 (.0245) (.0695) (4.20) <-.820E-4>

PSI/DC ; PHI/DA ; THE/DB -.0502 (.00120) (.0748) (.861) <-.388E-5>
XD/DB ; PHI/DA ; PSI/DP -.636 (.0676) (.816) [.0284;2.17] <-.165>
YD/DA ; THE/DB ; PSI/DP .148 (.00810) (.919) [-.0136;4.32] <.0206>

ZD/DC ; PHI/DA ; THE/DB 1.30 (0) (.0109) [.444;1.09] <.0168>
ZD/DC ; PHI/DA ; PSI/DP 7.46 (.0683) (.146) [.0798;.766] <.0436>
XD/DC ; PHI/DA ; THE/DB -.0526 (0) [.507;1.27] <-.0848>

XD/DC ; PHI/DA ; PSI/DP .0545 (.0689) (2.50) [-.286;3.40] <.109>
YD/DP ; PHI/DA ; THE/DB -.0948 (.00810) (.909) (2.33) (-2.53) <.00411>
ZD/DB ; PHI/DA ; PSI/DP -1.47 (0) (.0678) [.0666;2.26] <-.511>

ZD/DC ; PHI/DA ; THE/DB ; PSI/DP -1.21 (.00936) (.0687) <-.000779>
XD/DC ; PHI/DA ; THE/DB ; PSI/DP .00575 (.0675) (9.89) <.00384>

TABLE IV-5 CONTINUED
AH-IG TRANSFER FUNCTION FACTORS

CASE 81 HOVER AT 10000' SCAS OFF

DENOMINATOR: (0) (.349) (.658) [-.240; .407] [-.243; .545] [.953; .806] <.00733>

CONTROL NUMERATORS:

PHI/DA .493 (0) (.0661) (.479) [-.388; .325] [.919; .446] <.000328>
THE/DB -.150 (0) (.0137) (.362) (.430) (1.27) [-.189; .538] <-.000117>
PSI/DP -.664 (.463) [-.0253; .432] [-.458; .461] [.951; .886] <-.00957>

PHI/DB -.0455 (0) (.0667) (.361) (.420) (-3.52) [-.0894; .565] <.000518>
THE/DA .114 (0) (-.0207) (.272) (.556) [.0152; .540] <-.000104>

PHI/DA ;THE/DB -.0739 (0) (-.00291) (.0665) (.355) (.417) <.212E-5>
PHI/DA ;PSI/DP -.334 (.0185) [-.385; .323] [.938; .442] <-.000126>
THE/DB ;PSI/DP .0999 (.00481) (.284) (1.31) [-.135; .421] <.317E-4>

PHI/DB ;PSI/DP .0312 (.0185) (.321) (-3.50) [.0838; .557] <-.000201>
PHI/DP ;THE/DB -.0287 (0) (.376) (.493) [-.621; .0134] <-.956E-6>
PHI/DC ;THE/DB .00823 (0) (.0301) (.358) (.466) (-.523) <-.216E-4>

THE/DA ;PSI/DP -.0746 (-.00631) (.394) [-.0715; .564] <.588E-4>
THE/DP ;PHI/DA .00726 (0) (-.00214) (.140) [.479; .773] <-.130E-5>
THE/DC ;PHI/DA .00922 (0) (.346) (2.40) [-.536; .0425] <.138E-4>

PSI/DA ;THE/DB -.00492 (-.00286) (.322) (.995) (-1.20) (-5.58) <.301E-4>
PSI/DB ;PHI/DA -.00108 (.0210) (.0377) (.981) (-1.20) (-1.66) <-.167E-5>
XD/DB ;PHI/DA .625 (0) (.0664) (.338) (.422) [.0485; 1.95] <.0226>

YD/DA ;THE/DB -.127 (-.00286) (.0529) [.998; .378] [.0191; 4.31] <.509E-4>
ZD/DB ;PHI/DA .0793 (0) (.0663) (.481) (-1.39) [-.358; 1.33] <-.00617>
XD/DC ;PHI/DA -.0389 (0) (.0332) (.341) (1.83) [-.265; 3.16] <-.00805>

YD/DP ;THE/DB -.165 (.00674) (-.0449) (.348) (.578) [.0517; 2.31] <.535E-4>
ZD/DC ;PHI/DA -4.96 (0) (.127) (.248) (.476) [-.291; .270] <-.00541>

PHI/DA ;THE/DB ;PSI/DP .0501 (-.00290) (.0185) (.305) <-.820E-6>
PHI/DC ;THE/DB ;PSI/DP .0118 (.0203) (.0631) (.572) <.889E-5>
THE/DC ;PHI/DA ;PSI/DP -.0106 (.00952) (.0313) (1.47) <-.465E-5>

PSI/DC ;PHI/DA ;THE/DB -.0447 (-.00312) (.0238) (.351) <.116E-5>
XD/DB ;PHI/DA ;PSI/DP -.423 (.0185) (.293) [.0484; 1.95] <-.00876>
YD/DA ;THE/DB ;PSI/DP .0898 (-.00287) (.304) [-.0147; 4.24] <-.00141>

ZD/DC ;PHI/DA ;THE/DB .742 (0) (.0166) (.0529) (.345) <.000226>
ZD/DC ;PHI/DA ;PSI/DP 3.38 (.0164) (.425) [-.253; .262] <.00162>
XD/DC ;PHI/DA ;THE/DB -.00587 (0) (.107) (.342) (4.68) <-.00101>

XD/DC ;PHI/DA ;PSI/DP .0661 (.0230) (1.18) [-.248; 2.54] <.0116>
YD/DP ;PHI/DA ;THE/DB -.0568 (-.00290) (.123) (-.244) (.280) <-.138E-5>
ZD/DB ;PHI/DA ;PSI/DP -.0538 (.0185) (-1.39) [-.377; 1.31] <.00238>

ZD/DC ;PHI/DA ;THE/DB ;PSI/DP -.506 (.00671) (.0227) <-.771E-4>
XD/DC ;PHI/DA ;THE/DB ;PSI/DP .00358 (.0179) (6.23) <.000399>

TABLE IV-5 CONTINUED
AH-IG TRANSFER FUNCTION FACTORS

CASE 92 60KT AFT CG SCAS OFF

DENOMINATOR: (0) (.0194) (1.36) [-.0453;.247][-.766;.799][.358;1.20]<.00147>

CONTROL NUMERATORS:

PHI/DA .496 (0) [-.185;.303][.901;.745][.389;1.20]<.0366>
THE/DB -.171 (0) (.00326) (.0301) (-.895) (1.28) [.358;1.20]<-.277E-4>
PSI/DP -.928 (-.192) (-.280) (1.42) [-.0845;.287][.735;.839]<.00410>

PHI/DB .0346 (0) (.226) (-.243) (1.89) (3.55) [.356;1.24]<-.0197>
THE/DA .0867 (0) (-.00763) (.0496) (.882) [.363;1.20]<-.417E-4>

PHI/DA ;THE/DB -.0846 (0) (.0116) (.888) [.391;1.20]<-.00125>
PHI/DA ;PSI/DP -.473 (.0841) [-.167;.297][.880;.747]<-.00196>
THE/DB ;PSI/DP .158 (.0148) (-.180) (-.310) (.879) (1.29) <-.000148>

PHI/DB ;PSI/DP -.0457 (.0824) (.231) (-.249) [.889;2.41]<.00126>
PHI/DP ;THE/DB -.0545 (0) (.0145) (.923) [.424;.823]<-.000494>
PHI/DC ;THE/DB -.0183 (0) (.00593) (1.37) [.398;1.45]<-.000316>

THE/DA ;PSI/DP -.0817 (-.00407) (.874) [.181;.231]<.155E-4>
THE/DP ;PHI/DA .00264 (0) (-.00374) (.982) [-.222;2.13]<-.439E-4>
THE/DC ;PHI/DA .0199 (0) (.0255) (1.57) [.436;1.14]<.00104>

PSI/DA ;THE/DB -.00691 (.0117) (.872) (1.23) [-.854;2.09]<-.000379>
PSI/DB ;PHI/DA .0198 (.0751) (.259) (-.295) [.382;2.21]<-.000554>
XD/DB ;PHI/DA .603 (0) (.860) [-.393;1.20][.0154;2.15]<3.45>

YD/DA ;THE/DB -.144 (.0117) (.888) [.319;1.16][.0273;4.36]<-.0384>
ZD/DB ;PHI/DA 1.54 (0) (-.00910) [.405;1.20][.0867;2.22]<-.0990>
XD/DC ;PHI/DA -.0591 (0) (1.84) (8.46) [.439;1.19]<-1.31>

YD/DP ;THE/DB -.296 (.0148) (.915) [-.663;1.03][.622;1.87]<-.0150>
ZD/DC ;PHI/DA -7.41 (0) (.151) [.218;.622][.379;1.15]<-.570>

PHI/DA ;THE/DB ;PSI/DP .0806 (.0112) (.0837) (.876) <.661E-4>
PHI/DC ;THE/DB ;PSI/DP .0339 (.00700) (.0853) (1.34) <.270E-4>
THE/DC ;PHI/DA ;PSI/DP -.0198 (.0209) (.0851) (1.54) <-.541E-4>

PSI/DC ;PHI/DA ;THE/DB -.0256 (.00883) (.0912) (1.27) <-.262E-4>
XD/DB ;PHI/DA ;PSI/DP -.574 (.0838) (.854) [.0159;2.15]<-.190>
YD/DA ;THE/DB ;PSI/DP .145 (.0111) (.876) [-.00841;4.21]<.0251>

ZD/DC ;PHI/DA ;THE/DB 1.20 (0) (.0138) [.392;1.16]<.0223>
ZD/DC ;PHI/DA ;PSI/DP 7.09 (.0836) (.136) [.189;.638]<.0327>
XD/DC ;PHI/DA ;THE/DB -.0250 (0) (1.29) [.332;1.28]<-.0533>

XD/DC ;PHI/DA ;PSI/DP .589 (.0848) (1.66) <.0829>
YD/DP ;PHI/DA ;THE/DB -.101 (.0112) (.871) (2.55) (-2.68) <.00669>
ZD/DB ;PHI/DA ;PSI/DP -1.46 (-.00709) (.0840) [.0861;2.21]<.00426>

ZD/DC ;PHI/DA ;THE/DB ;PSI/DP -1.15 (.0126) (.0844) <-.00122>
XD/DC ;PHI/DA ;THE/DB ;PSI/DP .0230 (.0823) (1.30) <.00246>

TABLE IV-5 CONTINUED
AH-IG TRANSFER FUNCTION FACTORS

CASE 94 HOVER AT LIGHT WEIGHT SCAS OFF

DENOMINATOR: (0) (.393) (.779) [-.181;.287] [-.289;.440] [.731;.687] <.00231>

CONTROL NUMERATORS:

PHI/DA .484 (0) (.0792) (.487) [-.461;.248] [.884;.507] <.000294>
 THE/DB -.132 (0) (.0530) (.871) [-.221;.401] [.933;.473] <-.000219>
 PSI/DP -.840 (.715) [.0412;.247] [-.559;.336] [.677;.739] <-.00226>

PHI/DB .151 (0) (.0781) [-.0192;.481] [.983;.512] <.000714>
 THE/DA .0955 (0) (-.0375) (.338) (.694) [.0563;.326] <-.892E-4>

PHI/DA ;THE/DB -.0638 (0) (0) (.0782) [.982;.486] <-.00118>
 PHI/DA ;PSI/DP -.415 (.0252) [-.457;.246] [.900;.492] <-.000154>
 THE/DB ;PSI/DP .111 (.806) [-.901;.126] [.724;.408] <.000235>

PHI/DB ;PSI/DP -.130 (.0247) (.525) [-.0314;.471] <-.000372>
 PHI/DP ;THE/DB -.0296 (0) (-.0147) (.0679) [.921;.532] <.838E-5>
 PHI/DC ;THE/DB -.0111 (0) (.0576) (-.137) (.403) <-.353E-4>

THE/DA ;PSI/DP -.0832 (-.0197) (.636) [-.215;.303] <.957E-4>
 THE/DP ;PHI/DA -.00427 (0) (-.0108) (.149) (-.367) (1.35) <-.342E-5>
 THE/DC ;PHI/DA .00335 (0) (.0233) (.0560) (.430) (7.76) <.146E-4>

PSI/DA ;THE/DB -.00524 (0) (.502) (1.16) (-2.04) (-2.74) <-.0171>
 PSI/DB ;PHI/DA .000281 (-.00915) (.127) (-2.00) [.469;2.70] <.477E-5>
 XD/DB ;PHI/DA .629 (0) (.0786) (.981;.479) [.0477;1.81] <.0371>

YD/DA ;THE/DB -.115 (0) (.0638) [.981;.470] [.0226;4.20] <-.0287>
 ZD/DB ;PHI/DA .0946 (0) (.0790) (.519) (-1.69) [.322;1.38] <-.0125>
 XD/DC ;PHI/DA -.0104 (0) (.0700) (.428) (2.87) [-.650;5.28] <-.0250>

YD/DP ;THE/DB -.221 (-.0261) (-.0582) [.934;.530] [-.0130;2.05] <.000396>
 ZD/DC ;PHI/DA -7.27 (0) (.0572) (-.109) (.438) [.738;.222] <.000972>

PHI/DA ;THE/DB ;PSI/DP .0547 (0) (.0240) (.460) <.000603>
 PHI/DC ;THE/DB ;PSI/DP .0163 (.0166) (.0439) (1.14) <.136E-4>
 THE/DC ;PHI/DA ;PSI/DP -.0205 (.00916) (.0304) <-.571E-5>

PSI/DC ;PHI/DA ;THE/DB -.0351 (0) (.0317) (.584) <-.000649>
 XD/DB ;PHI/DA ;PSI/DP -.539 (.0245) (.445) [.0476;1.81] <-.0193>
 YD/DA ;THE/DB ;PSI/DP .105 (0) (.458) [-.0137;4.09] <.806>

ZD/DC ;PHI/DA ;THE/DB .958 (0) (.0273) (.0557) (.426) <.000620>
 ZD/DC ;PHI/DA ;PSI/DP 6.25 (.0234) (-.0657) [.864;.167] <-.000267>
 XD/DC ;PHI/DA ;THE/DB -.0394 (0) (.116) (.401) <-.00183>

XD/DC ;PHI/DA ;PSI/DP .0102 (.0271) (2.90) [-.806;4.73] <.0179>
 YD/DP ;PHI/DA ;THE/DB -.0810 (0) (.115) (-.250) (.442) <.00103>
 ZD/DB ;PHI/DA ;PSI/DP -.0812 (.0253) (-1.69) [.329;1.37] <.00653>

ZD/DC ;PHI/DA ;THE/DB ;PSI/DP -.824 (.00947) (.0311) <-.000242>
 XD/DC ;PHI/DA ;THE/DB ;PSI/DP .0333 (.0209) <.000695>

TABLE IV-5 CONTINUED
AH-IG TRANSFER FUNCTION FACTORS

CASE 95 60KT AT LIGHT WEIGHT SCAS OFF

DENOMINATOR: (0) (-.0190) (1.28) [-.0153;.252][.725;.887][.430;1.35]<-.00221>

CONTROL NUMERATORS:

PHI/DA .466 (0) [-.135;.292][.838;.877][.415;1.34]<.0550>
THE/DB -.129 (0) (-.0142) (-.0168) [.996;1.15][.433;1.35]<.750E-4>
PSI/DP -1.06 (-.294) (-.468) (1.32) [-.0856;.280][.684;.949]<.0136>

PHI/DB .0332 (0) (.217) (-.224) [-.441;1.36][.790;2.37]<-.0168>
THE/DA .0785 (0) (-.0119) (-.0505) (1.11) [.393;1.32]<-.919E-4>

PHI/DA ;THE/DB -.0602 (0) (.00921) (1.16) [.419;1.34]<-.00116>
PHI/DA ;PSI/DP -.504 (.0997) [-.129;.290][.825;.870]<-.00320>
THE/DB ;PSI/DP .137 (-.0102) (-.298) (.642) [.991;1.08]<-.000310>

PHI/DB ;PSI/DP -.0465 (.0948) (.254) (-.261) [.633;2.26]<.00149>
PHI/DP ;THE/DB -.0366 (0) (.0101) (1.18) [.406;1.53]<-.00102>
PHI/DC ;THE/DB -.0105 (0) (0) (2.42) [.420;1.21]<-.0371>

THE/DA ;PSI/DP -.0842 (-.0205) (1.11) [.251;.187]<.671E-4>
THE/DP ;PHI/DA -.00673 (0) (-.0231) (-.971) (1.36)<-.000205>
THE/DC ;PHI/DA .00504 (0) (.0246) (8.15) [.450;1.29]<.00169>

PSI/DA ;THE/DB -.00443 (.00924) (1.10) (1.64) [-.939;2.18]<-.000351>
PSI/DB ;PHI/DA .0174 (.0880) (-.364) (-.493) [-.123;1.51]<-.000622>
XD/DB ;PHI/DA .536 (0) (1.09) [.419;1.35][.0244;1.96]<.4.07>

YD/DA ;THE/DB -.109 (.00925) (1.17) [.342;1.29][.0345;4.27]<-.0355>
ZD/DB ;PHI/DA 1.76 (0) (-.00204) [-.425;1.36][.0902;1.99]<.0262>
XD/DC ;PHI/DA .0707 (0) (-2.97) [.469;1.34][.446;2.43]<-2.20>

YD/DP ;THE/DB -.265 (.0102) (1.19) [-.696;1.53][.779;2.04]<-.0314>
ZD/DC ;PHI/DA -8.61 (0) (-.144) [-.156;.670][.419;1.30]<-.942>

PHI/DA ;THE/DB ;PSI/DP .0651 (.00877) (.0995) (1.15)<.656E-4>
PHI/DC ;THE/DB ;PSI/DP .0208 (.00337) (.105) (2.14)<.157E-4>
THE/DC ;PHI/DA ;PSI/DP -.00562 (.0214) (-.100) (7.62)<-.921E-4>

PSI/DC ;PHI/DA ;THE/DB -.0155 (.00541) (.110) (1.81)<-.168E-4>
XD/DB ;PHI/DA ;PSI/DP -.579 (.0995) (1.09) [.0240;1.96]<-.241>
YD/DA ;THE/DB ;PSI/DP .125 (.00872) (1.16) [-.00804;4.12]<.0213>

ZD/DC ;PHI/DA ;THE/DB 1.09 (0) (.0102) [.420;1.31]<.0191>
ZD/DC ;PHI/DA ;PSI/DP 9.33 (.0996) (.141) [.139;.665]<.0578>
XD/DC ;PHI/DA ;THE/DB -.0149 (0) (2.59) [.392;1.42]<-.0783>

XD/DC ;PHI/DA ;PSI/DP -.0701 (.100) (-3.04) [.498;2.54]<.138>
YD/DP ;PHI/DA ;THE/DB -.0927 (.00877) (1.15) (2.59) (-2.75)<-.00664>
ZD/DB ;PHI/DA ;PSI/DP -1.90 (.00341) (.0997) [-.0883;2.00]<-.00259>

ZD/DC ;PHI/DA ;THE/DB ;PSI/DP -1.18 (.00936) (.100)<-.00111>
XD/DC ;PHI/DA ;THE/DB ;PSI/DP .0155 (.0981) (2.69)<.00410>

TABLE IV-5 CONTINUED
AH-IG TRANSFER FUNCTION FACTORS

CASE 100 MAX CLIMB AT 60KT LIGHT WEIGHT SCAS OFF

DENOMINATOR: (0) [-.354;.205][.0882;.737][.563;1.31][.406;1.36]<.0732>

CONTROL NUMERATORS:

PHI/DA .531 (0) [-.139;.244][.331;1.41][.483;1.70]<.181>
THE/DB -.126 (0) (-.0213) (1.60) [-.0131;.634][.636;1.22]<.00259>
PSI/DP -1.03 (1.07) [-.0180;.137][-.688;.563][.362;1.47]<-.0141>

PHI/DB -.0135 (0) (-.444) (-8.56) [.637;.814][.732;2.02]<-.139>
THE/DA .0631 (0) (-.0398) (.0558) (2.18) [.225;1.50]<-.000685>

PHI/DA ;THE/DB -.0671 (0) (-.0183) (1.62) [.449;1.60]<.00510>
PHI/DA ;PSI/DP -.555 (.0598) [-.122;.227][.402;1.44]<-.00353>
THE/DB ;PSI/DP .133 (-.00442) (1.01) (1.62) [-.695;.547]<-.000289>

PHI/DB ;PSI/DP .0278 (.0621) (-.353) (-.456) (1.70) (-5.21)<.00246>
PHI/DP ;THE/DB -.0272 (0) (-.00380) (-1.52) (1.62) (2.68)<-.000682>
PHI/DC ;THE/DB -.0224 (0) (-.0472) (1.24) (8.45)<.0111>

THE/DA ;PSI/DP -.0539 (.00244) (2.07) [-.629;.712]<-.000138>
THE/DP ;PHI/DA .0213 (0) (.00267) (1.59) [.103;2.18]<.000431>
THE/DC ;PHI/DA -.0699 (0) (.00590) (-2.35) [.377;1.51]<.00221>

PSI/DA ;THE/DB .0472 (-.0183) (-.516) (1.47) (2.75)<.00179>
PSI/DB ;PHI/DA -.0331 (.0468) [-.136;.386][.0478;2.36]<-.00129>
XD/DB ;PHI/DA .762 (0) (.990) [.452;1.61][.0521;2.11]<8.75>

YD/DA ;THE/DB -.126 (-.0183) (1.62) [.361;1.50][.0693;4.37]<.160>
ZD/DB ;PHI/DA 1.77 (0) (-.0114) [.421;1.59][.0326;2.34]<-.281>
XD/DC ;PHI/DA .152 (0) (-2.53) [.382;1.50]<-.0612;3.74>

YD/DP ;THE/DB -.247 (-.00438) (1.61) (-1.68) (2.27) [-.135;1.97]<-.0258>
ZD/DC ;PHI/DA -9.90 (0) (.0870) [.0235;1.16][.384;1.50]<-2.59>

PHI/DA ;THE/DB ;PSI/DP .0714 (-.0145) (.0577) (1.62)<-.967E-4>
PHI/DC ;THE/DB ;PSI/DP .0309 (.0513) (-.0707) (1.69)<-.000189>
THE/DC ;PHI/DA ;PSI/DP .0508 (.00466) (.0608) (-3.86)<-.554E-4>

PSI/DC ;PHI/DA ;THE/DB -.0744 (-.0321) (.0702) (.962)<.000161>
XD/DB ;PHI/DA ;PSI/DP -.799 (.0569) (1.03) [.0523;2.11]<-.208>
YD/DA ;THE/DB ;PSI/DP .139 (-.0140) (1.61) [-.0257;4.25]<-.0564>

ZD/DC ;PHI/DA ;THE/DB 1.48 (0) (-.0209) [.403;1.50]<-.0697>
ZD/DC ;PHI/DA ;PSI/DP 10.3 (.0568) (.0691) [.00942;1.25]<.0630>
XD/DC ;PHI/DA ;THE/DB .0810 (0) (-2.23) [.395;1.58]<-.450>

XD/DC ;PHI/DA ;PSI/DP -.0934 (.3607) (-4.12) [.0159;4.06]<.385>
YD/DP ;PHI/DA ;THE/DB -.104 (-.0147) (-2.06) [1.00;1.66]<-.00862>
ZD/DB ;PHI/DA ;PSI/DP -1.85 (-.00404) (.0586) [.0326;2.34]<.00240>

ZD/DC ;PHI/DA ;THE/DB ;PSI/DP -1.50 (-.0191) (.0589)<.00169>
XD/DC ;PHI/DA ;THE/DB ;PSI/DP -.0612 (.0603) (-3.75)<.0138>

TABLE IV-5 CONTINUED
AH-IG TRANSFER FUNCTION FACTORS

CASE 107 HOVER AT HEAVY WEIGHT SCAS OFF

DENOMINATOR: (0) (.378) (.801) [-.265; .399] [-.210; .578] [.903; .737] <.00871>

CONTROL NUMERATORS:

PHI/DA .542 (0) (.0689) (.518) [-.383; .324] [.908; .486] <.000481>
 THE/DB -.191 (0) (.0177) (1.17) [-.979; .405] [-.180; .566] <-.000208>
 PSI/DP -.766 (.544) [-.0132; .400] [-.484; .443] [.898; .863] <-.00973>

PHI/DB .197 (0) (.0686) [.989; .435] [.0374; .584] <.000874>
 THE/DA .127 (0) (-.0212) (.301) (.612) [-.0183; .523] <-.000135>

PHI/DA ;THE/DB -.104 (0) (-.00165) (.0687) [.996; .423] <.210E-5>
 PHI/DA ;PSI/DP -.428 (.0181) [-.378; .323] [.932; .479] <-.000186>
 THE/DB ;PSI/DP .146 (.0280) (.266) (1.17) [-.0907; .339] <.000146>

PHI/DB ;PSI/DP -.160 (.0179) (.373) [-.0193; .565] <-.000341>
 PHI/DP ;THE/DB -.0723 (0) (-.0154) (.0245) [.952; .400] <.437E-5>
 PHI/DC ;THE/DB .0137 (0) (.0308) (.229) (.394) (-.926) <-.353E-4>

THE/DA ;PSI/DP -.100 (-.00918) (.453) [-.0821; .498] <.000104>
 THE/DP ;PHI/DA -.000246 (0) (-.00494) (.155) (-2.40) (7.57) <-.342E-5>
 THE/DC ;PHI/DA .00341 (0) (.393) (7.88) [.607; .0430] <.196E-4>

PSI/DA ;THE/DB -.00640 (-.00159) (.363) (1.18) (-1.61) (-4.37) <.306E-4>
 PSI/DB ;PHI/DA .00600 (.00902) (.0773) (-.739) (1.13) <-.349E-5>
 XD/DB ;PHI/DA .713 (0) (.0688) [.998; .417] [-.0499; 2.16] <.0398>

YD/DA ;THE/DB -.168 (-.00160) (.0565) [-.992; .416] [-.0141; 4.44] <.516E-4>
 ZD/DB ;PHI/DA .103 (0) (.0688) (.523) (-1.44) [.370; 1.46] <-.0115>
 XD/DC ;PHI/DA -.00796 (0) (.0385) (.389) (3.40) [-.598; 5.65] <-.0129>

YD/DP ;THE/DB -.259 (.0210) (-.0314) [.959; .406] [.0300; 2.96] <.000247>
 ZD/DC ;PHI/DA -6.03 (0) (.117) (.300) (.506) [-.272; .267] <-.00763>

PHI/DA ;THE/DB ;PSI/DP .0818 (-.00168) (.0179) (.339) <-.836E-6>
 PHI/DC ;THE/DB ;PSI/DP .0341 (.0167) (.0341) (.596) <.116E-4>
 THE/DC ;PHI/DA ;PSI/DP -.00254 (.00940) (.0311) (7.91) <-.588E-5>

PSI/DC ;PHI/DA ;THE/DB -.0643 (-.00191) (.0233) (.411) <.118E-5>
 XD/DB ;PHI/DA ;PSI/DP -.563 (.0179) (.328) [-.0498; 2.16] <-.0155>
 YD/DA ;THE/DB ;PSI/DP .137 (-.00170) (.338) [-.00949; 4.38] <-.00151>

ZD/DC ;PHI/DA ;THE/DB 1.15 (0) (.0178) (.0544) (.390) <.000435>
 ZD/DC ;PHI/DA ;PSI/DP 4.77 (.0173) (.463) [-.248; .274] <.00285>
 XD/DC ;PHI/DA ;THE/DB -.0404 (0) (.108) (.385) <-.00168>

XD/DC ;PHI/DA ;PSI/DP .0215 (.0222) (2.43) [-.563; 3.52] <.0144>
 YD/DP ;PHI/DA ;THE/DB -.0772 (-.00168) (.122) (-.285) (.312) <-.141E-5>
 ZD/DB ;PHI/DA ;PSI/DP -.0814 (.0181) (-1.46) [.388; 1.44] <.00444>

ZD/DC ;PHI/DA ;THE/DB ;PSI/DP -.911 (.00625) (.0224) <-.000128>
 XD/DC ;PHI/DA ;THE/DB ;PSI/DP .0337 (.0165) <.000556>

TABLE IV-5 CONCLUDED
AH-IG TRANSFER FUNCTION FACTORS

CASE I08 60KT AT HEAVY WEIGHT SCAS OFF

DENOMINATOR: (0) (.135) (1.59) [-.0797;.289][.688;.781][.258;1.17]<.0149>

CONTROL NUMERATORS:

PHI/DA .524 (0) [-.160;.351][.846;.737][.372;1.18]<.0489>
THE/DB -.192 (0) (.00387) (.123) (.748) (1.52) [.250;1.17]<-.000143>
PSI/DP -.849 (1.62) [-.00429;.226][-.0169;.325][.698;.755]<-.00423>

PHI/DB .0265 (0) (.277) (-.376) [.161;1.13][.995;3.14]<-.0348>
THE/DA .0969 (0) (-.00838) (.0751) (.745) [.333;1.18]<-.631E-4>

PHI/DA ;THE/DB -.101 (0) (.00587) (.747) [-.385;1.18]<-.000615>
PHI/DA ;PSI/DP -.457 (-.0609) [-.134;.343][.805;.730]<-.00175>
THE/DB ;PSI/DP .163 (.00329) (.734) (1.53) [-.0225;.267]<.427E-4>

PHI/DB ;PSI/DP -.0409 (.0614) (.277) (-.373) [.633;2.08]<.00112>
PHI/DP ;THE/DB -.0846 (0) (.00323) (-.484) (.715) (1.29) <.000122>
PHI/DC ;THE/DB -.0176 (0) (0) (1.02) [.240;2.31]<-.0952>

THE/DA ;PSI/DP -.0822 (-.00271) (.744) [.0605;.298]<.148E-4>
THE/DP ;PHI/DA .00693 (0) (-.00239) (.789) [-.230;1.77]<-.408E-4>
THE/DC ;PHI/DA .0238 (0) (.0233) (1.51) [.472;1.07]<.000968>

PSI/DA ;THE/DB -.00509 (.00590) (.745) (1.36) (-1.53) (-4.05) <-.000189>
PSI/DB ;PHI/DA .0213 (.0573) (.278) (-.534) [-.297;1.68]<-.000509>
XD/DB ;PHI/DA .644 (0) (.704) [.384;1.18][.0197;2.30]<3.36>

YD/DA ;THE/DB -.163 (.00591) (.747) [.334;1.15][.0175;4.48]<-.0192>
ZD/DB ;PHI/DA 1.33 (0) (-.0155) [.393;1.19][.0947;2.36]<-.165>
XD/DC ;PHI/DA -.0853 (0) (1.39) [.470;1.11][-.0973;3.02]<-1.35>

YD/DP ;THE/DB -.290 (.00329) (.708) (-.822) (1.24) [.121;2.51]<.00432>
ZD/DC ;PHI/DA -6.60 (0) (.198) [.252;.682][.329;1.10]<-.737>

PHI/DA ;THE/DB ;PSI/DP .0876 (.00550) (.0607) (.738) <.216E-4>
PHI/DC ;THE/DB ;PSI/DP .0450 (0) (.0589) (1.01) <.00269>
THE/DC ;PHI/DA ;PSI/DP -.0231 (.0169) (.0624) (1.37) <-.335E-4>

PSI/DC ;PHI/DA ;THE/DB -.0355 (.00282) (.0663) (1.04) <-.687E-5>
XD/DB ;PHI/DA ;PSI/DP -.560 (.0607) (.699) [.0191;2.30]<-.126>
YD/DA ;THE/DB ;PSI/DP .146 (.00548) (.738) [-.00776;4.41]<.0115>

ZD/DC ;PHI/DA ;THE/DB 1.21 (0) (.00803) [.376;1.14]<.0125>
ZD/DC ;PHI/DA ;PSI/DP 5.78 (.0606) (.154) [.160;.725]<.0284>
XD/DC ;PHI/DA ;THE/DB -.0128 (0) (2.17) [.379;1.34]<-.0497>

XD/DC ;PHI/DA ;PSI/DP .0880 (.0619) (1.26) [-.115;3.04]<.0634>
YD/DP ;PHI/DA ;THE/DB -.0802 (.00550) (.735) (2.52) (-2.68) <.00218>
ZD/DB ;PHI/DA ;PSI/DP -1.16 (-.0129) (.0608) [.0909;2.38]<.00514>

ZD/DC ;PHI/DA ;THE/DB ;PSI/DP -1.05 (.00698) (.0612) <-.000448>
XD/DC ;PHI/DA ;THE/DB ;PSI/DP .0114 (.0600) (2.39) <.00163>

SECTION V

BELL UH-1H

The UH-1H is a single turbine general purpose utility helicopter. The rotor system includes a two-bladed, all-metal, semi-rigid main rotor on an underslung feathering axis hub with a stabilizer bar mounted at right angles to the main rotor blades (see Fig. V-1). The vehicle is powered by a Lycoming T53-L-13 turbo-shaft engine rated at 1400 shaft horsepower.

The control system, as shown in Fig. V-2, is all mechanical with hydraulic actuation. Mechanical stability augmentation is supplied by the stabilizer bar which provides feedback of roll rate and pitch rate about the rotor mast axis. The combination of stabilizer bar inertia and a stabilizer bar dashpot provides a three second lag in the angular rate feedbacks. (This may be interpreted also as a slowly washed out feedback of roll attitude and pitch attitude.) Detailed stabilizer bar equations of motion are presented in Volume Two.

The derivative data presented here were produced by the AGAJ7407 version of the manufacturer's C81 Rotorcraft Flight Simulation Computer Program. Transfer functions are given for the helicopter with and without the stabilizer bar.

Reference 5, the basic data source, provides additional information for the vehicle including detailed drawings, loading breakdowns, control system linkage schematics, and further details concerning the stabilizer bar.

Preceding page blank

PRECEDING PAGE BLANK NOT FILMED

TABLE V-1
UH-1H DESCRIPTIVE DATA

MAIN ROTOR

Blades 2
 Radius 7.32 m (24 ft)
 Chord 0.533 m (1.75 ft)
 Section NACA 0012
 Hub type Teetering
 Undersling 0.132 m (0.433 ft)
 Twist -10.9 deg
 Pitch flap coupling (δ_3) Zero
 Shaft tilt 5 deg forward
 Design rpm 314 to 324 (power on), 294 to 339 (power off)
 Hub location FS 133.5, WL 136.5
 Blade flapping inertia 1641.2 kg-m² (1210.5 slug-ft²)

TAIL ROTOR

Blades 2
 Radius 2.59 m (8.5 ft)
 Chord 0.297 m (0.958 ft)
 Twist Zero
 Gear ratio 5.123
 Hub location FS 479.4, WL 137.6, BL -15.16

ELEVATOR (EACH SIDE, EXCLUDING FUSELAGE CARRY-THROUGH)

Area 1.016 m² (10.936 ft²)
 Aspect ratio 2.009
 Center of pressure location FS 363.0, BL \pm 28.1, WL 64.83
 Incidence Variable

VERTICAL STABILIZER

Area 1.036 m² (11.15 ft²)
 Aspect ratio 1.426
 Center of pressure location FS 450.3, BL 0.4, WL 104.7

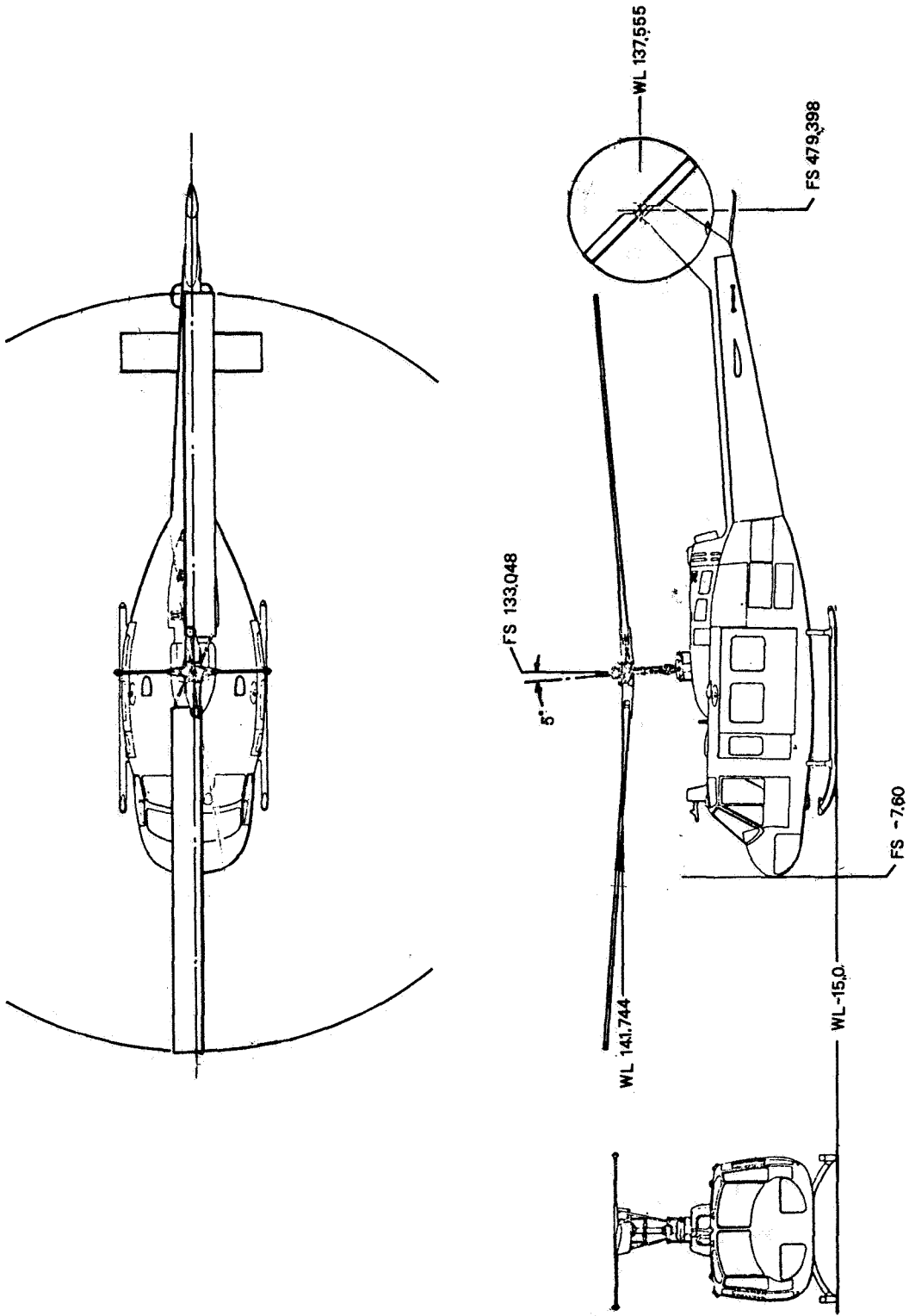

Figure V-1. UH-1H General Arrangement

a. Block Diagram

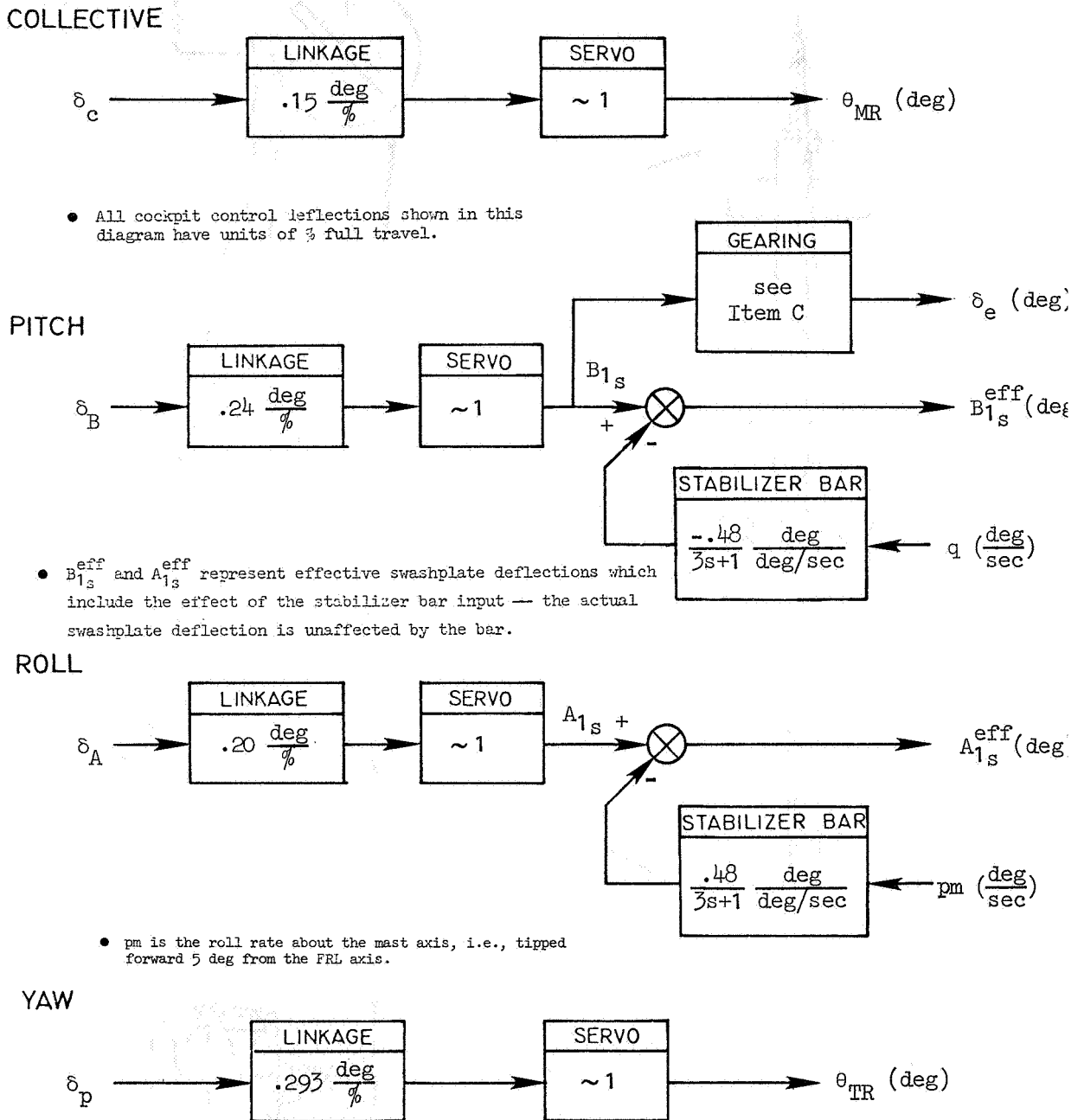

Figure V-2. UH-1H Control System Description

b. Cockpit Controller Characteristics

CONTROLLER	100% FULL TRAVEL cm (in)	FORCE GRADIENT N/cm (lb/in)
Collective, δ_c	27.2 (10.7)	—
Longitudinal Cyclic, δ_B	33.0 (13.)	2.12 (1.21)
Lateral Cyclic, δ_A	33.0 (13.)	1.38 (.79)
Pedal, δ_P	16.5 (6.5)	12.8 (7.3)

c. Swashplate-to-Elevator Gearing

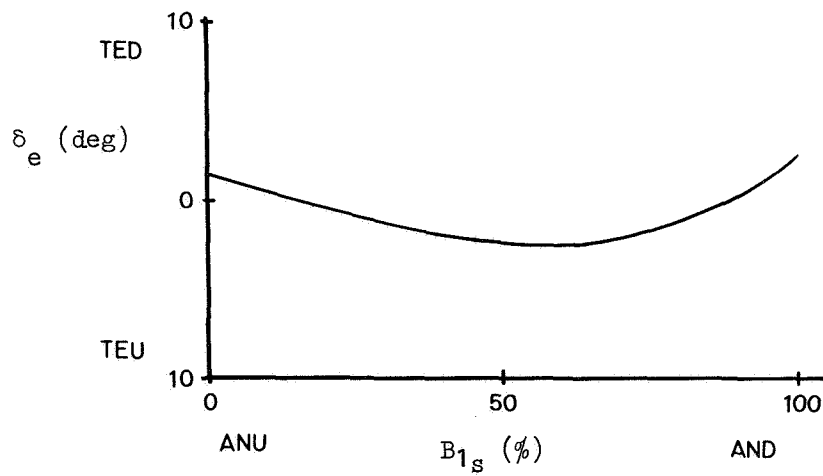
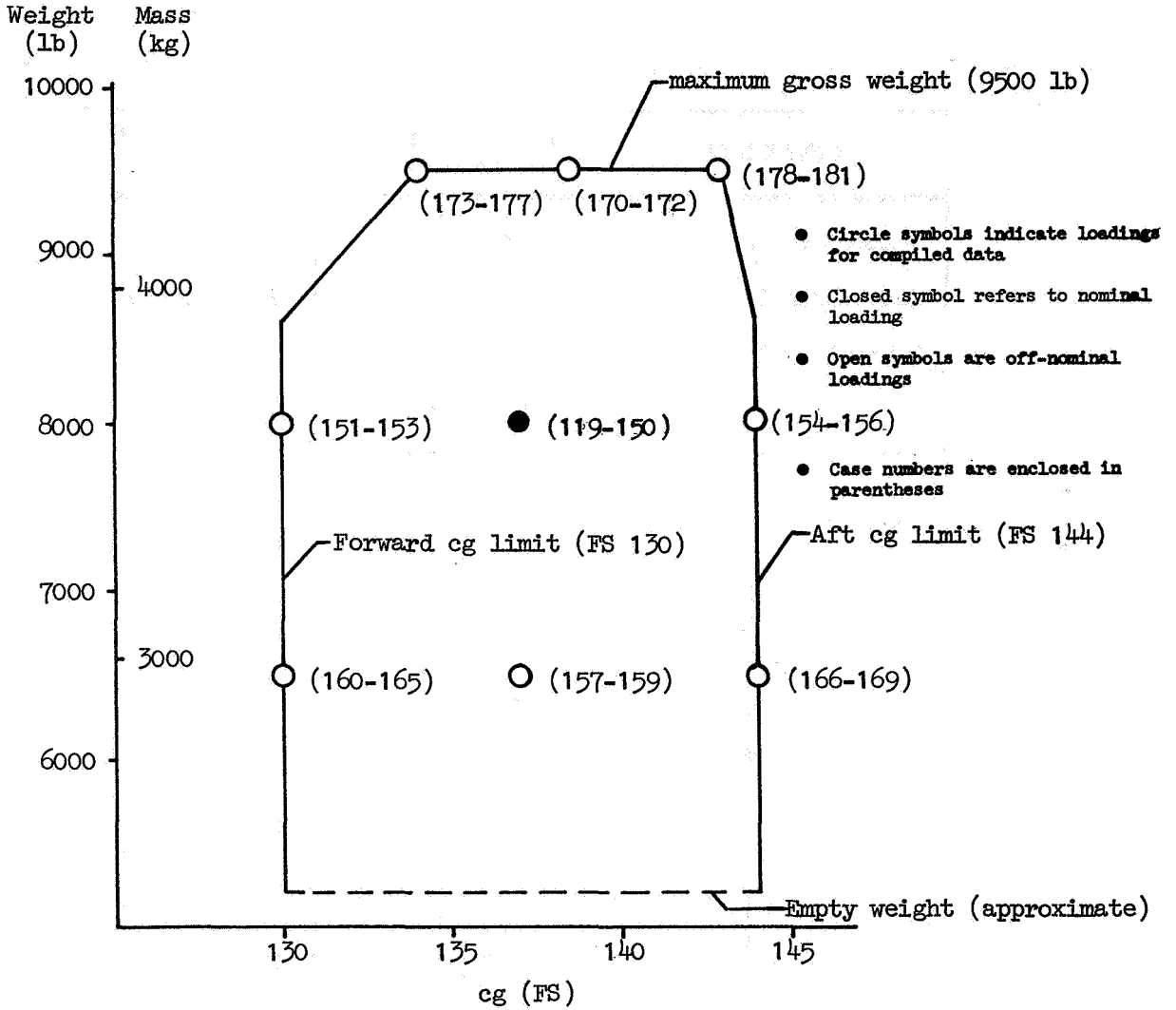

Figure V-2 (Concluded)

a. Loading Envelope



b. Moments of Inertia for Compiled Data

CONDITION	MASS (WEIGHT) kg (lb)	cg		I_x	I_y kg-m ² (slug-ft ²)	I_z	I_{xz}
		FS	WL				
Nominal Weight	3629 (8000)	130 to 144	57.5	3966(2925)	14684(10830)	12541(9250)	1695(1250)
Light Weight	2948 (6500)	130 to 144	61.0	3593(2650)	14033(10350)	11830(8725)	1695(1250)
Heavy Weight	4309 (9500)	134 to 143	54.0	4339(3200)	15321(11300)	13253(9775)	1695(1250)

Figure V-3. UH-1H Loading Summary

TABLE V-2

UH-1H INDEX OF FLIGHT CONDITIONS
FOR DERIVATIVES AND TRANSFER FUNCTION FACTORS

CASE	CONDITION	AIRSPEED kt	VERTICAL VELOCITY m/sec(ft/sec)	ALTITUDE m(ft)	MASS (WEIGHT) kg(lb)	cg FS	REPORT PAGE NUMBER		
							DERIVA- TIVES SI(US)	TRANSFER FUNCTIONS	
								BAR OFF	BAR ON
119	Airspeed Variation	-40	Zero	Sea Level	3629 (8000)	137	220(241)	262	263
120	↓	-20	↓	↓	↓	↓	↓	264	265
121	↓	-10	↓	↓	↓	↓	↓	↓	↓
122	↓	Hover	↓	↓	↓	↓	221(242)	266*	270*
123	↓	10	↓	↓	↓	↓	↓	↓	↓
124	↓	20	↓	↓	↓	↓	↓	274*	278*
125	↓	40	↓	↓	↓	↓	222(243)	282	↓
126	↓	60	↓	↓	↓	↓	↓	283*	287*
127	↓	80	↓	↓	↓	↓	↓	291	292
128	↓	100	↓	↓	↓	↓	223(244)	295	294
129	↓	120	↓	↓	↓	↓	↓	295	296
130	↓	130	↓	↓	↓	↓	↓	297	298
131	Maximum Power Climb	Zero†	11.1 (36.3)	↓	↓	↓	224(245)	↓	↓
132	↓	60	12.4 (40.6)	↓	↓	↓	↓	↓	↓
133	↓	100	9.7 (31.8)	↓	↓	↓	↓	299	300
134	Autorotation	60	-8.1 (-26.6)	↓	↓	↓	225(246)	301	302
135	↓	100	-15.0 (-49.1)	↓	↓	↓	↓	↓	↓
136	Descent	Zero†	-3.0 (-10)	↓	↓	↓	↓	↓	↓
137	↓	↓	-6.1 (-20)	↓	↓	↓	226(247)	↓	↓
138	Climb	↓	3.0 (10)	↓	↓	↓	↓	↓	↓
139	↓	↓	6.1 (20)	↓	↓	↓	↓	↓	↓
140	↓	60	6.1 (20)	↓	↓	↓	227(248)	↓	↓
141	↓	↓	3.0 (10)	↓	↓	↓	↓	↓	↓
142	Descent	↓	-3.0 (-10)	↓	↓	↓	↓	↓	↓
143	↓	↓	-6.1 (-20)	↓	↓	↓	228(249)	↓	↓
144	Operation at Altitude	Hover	Zero	3048 (10000)	↓	↓	↓	↓	↓
145	↓	60	↓	↓	↓	↓	↓	↓	↓
146	↓	100	↓	↓	↓	↓	229(250)	↓	↓
147	Max Climb at Altitude	Zero†	10.1 (33.2)	↓	↓	↓	↓	↓	↓
148	↓	60	10.9 (35.6)	↓	↓	↓	↓	↓	↓
149	Autorotation@Altitude	60	-8.1 (-26.7)	↓	↓	↓	230(251)	↓	↓
150	↓	100	-14.3 (-47.7)	↓	↓	↓	↓	↓	↓
151	Fwd cg, Nominal Weight	Hover	Zero	Sea Level	↓	130	↓	↓	↓
152	↓	60	↓	↓	↓	↓	231(252)	↓	↓
153	↓	100	↓	↓	↓	↓	↓	↓	↓
154	Aft cg, Nominal Weight	Hover	↓	↓	↓	144	↓	↓	↓
155	↓	60	↓	↓	↓	↓	232(253)	↓	↓
156	↓	100	↓	↓	↓	↓	↓	↓	↓
157	Light Weight	0	↓	↓	2948 (6500)	137	↓	↓	↓
158	↓	60	↓	↓	↓	↓	233(254)	↓	↓
159	↓	100	↓	↓	↓	↓	↓	↓	↓
160	Fwd cg, Light Weight	Hover	↓	↓	↓	130	↓	↓	↓
161	↓	60	↓	↓	↓	↓	234(255)	↓	↓
162	...and Max Climb	Zero†	18.1 (59.4)	↓	↓	↓	↓	↓	↓
163	↓	60	16.5 (54.)	↓	↓	↓	↓	↓	↓
164	...and Autorotation	Zero†	-15.8 (-52.)	↓	↓	↓	235(256)	↓	↓
165	↓	60	-9.3 (-30.5)	↓	↓	↓	↓	↓	↓
166	Aft cg, Light Weight	Hover	Zero	↓	↓	144	↓	↓	↓
167	↓	60	Zero	↓	↓	↓	236(257)	↓	↓
168	...and Max Climb	↓	16.6 (54.3)	↓	↓	↓	↓	↓	↓
169	...and Autorotation	↓	-10.0 (-32.8)	↓	↓	↓	↓	↓	↓
170	Heavy Weight	Hover	Zero	↓	4309 (9500)	138.5	237(258)	↓	↓
171	↓	60	↓	↓	↓	↓	↓	↓	↓
172	↓	100	↓	↓	↓	↓	↓	↓	↓
173	Fwd cg, Heavy Weight	Hover	↓	↓	↓	134	238(259)	↓	↓
174	↓	60	↓	↓	↓	↓	↓	↓	↓
175	...and Max Climb	Zero†	4.0 (13.0)	↓	↓	↓	↓	↓	↓
176	↓	60	8.4 (27.5)	↓	↓	↓	239(260)	↓	↓
177	...and Autorotation	60	-7.7 (-25.4)	↓	↓	↓	↓	↓	↓
178	Aft cg, Heavy Weight	Hover	Zero	↓	↓	143	↓	↓	↓
179	↓	60	Zero	↓	↓	↓	240(261)	↓	↓
180	...and Max Climb	↓	9.7 (31.7)	↓	↓	↓	↓	↓	↓
181	...and Autorotation	↓	-7.9 (-25.9)	↓	↓	↓	↓	↓	↓

* Indicates the extensive list of transfer function factors including gust numerators.

† Zero forward velocity, i.e., airspeed equal to vertical velocity.

TABLE V-3
UH-1H STABILITY AND CONTROL DERIVATIVES -- SI UNITS
(BODY-FIXED FRL AXIS SYSTEM)

CASE 119		-40 KT		LEVEL FLIGHT AT SEA LEVEL			3629 KG	MID CG		
	PHI	THETA	PSI	ALPHA	BETA	GAMMA	ØMR	B1S	A1S	ØTR
	-0.70	3.38	0.00	-176.62	0.04	180.00	12.71	-2.98	-0.36	2.54
	IDOT	ZDOT	UØ	VØ	WØ	VTO				
	-20.58	0.00	-20.54	0.01	-1.21	20.58				
	U	W	Q	V	P	R	DC	DB	DA	DP
X	-0.0234	0.0452	0.4580	-0.0031	-0.4160	-0.0601	0.0851	0.1378	-0.0002	0.0051
Z	0.1767	-0.6921	0.1360	-0.0113	0.1803	0.5949	-1.2490	-0.1892	-0.0043	-0.0030
M	0.0013	0.0275	-0.0564	0.0004	0.2072	0.0455	-0.0140	-0.0685	0.0002	0.0129
Y	-0.0021	-0.0217	-0.3736	-0.0479	-0.4910	0.3021	-0.0368	-0.0039	0.1049	0.2032
L'	0.0061	-0.0512	-0.7668	-0.0560	-0.9371	0.2419	-0.0605	-0.0097	0.2194	0.1670
N'	0.0251	-0.0403	0.0669	0.0861	-0.0318	-0.8473	0.0939	-0.0118	0.0335	-0.4887

CASE 120		-20 KT		LEVEL FLIGHT AT SEA LEVEL			3629 KG	MID CG		
	PHI	THETA	PSI	ALPHA	BETA	GAMMA	ØMR	B1S	A1S	ØTR
	-0.90	2.53	0.00	-177.47	0.04	180.00	13.58	-3.23	-0.72	4.41
	IDOT	ZDOT	UØ	VØ	WØ	VTO				
	-10.29	0.00	-10.28	0.01	-0.46	10.29				
	U	W	Q	V	P	R	DC	DB	DA	DP
X	-0.0122	0.0142	0.2947	-0.0047	-0.4173	-0.0682	0.0549	0.1280	-0.0008	0.0053
Z	0.2715	-0.4965	-0.3016	-0.0277	0.0518	0.5862	-1.1182	-0.0757	-0.0019	0.0043
M	0.0195	0.0104	-0.1062	0.0024	0.2168	0.0457	-0.0036	-0.0661	0.0005	0.0113
Y	-0.0014	-0.0171	-0.3948	-0.0389	-0.3940	0.2135	-0.0362	-0.0032	0.1033	0.1699
L'	0.0136	-0.0395	-0.8008	-0.0473	-0.7528	0.1640	-0.0526	-0.0064	0.2170	0.1415
N'	0.0342	-0.0206	0.2140	0.0627	-0.0815	-0.6211	0.1346	-0.0028	0.0343	-0.4081

CASE 121		-10 KT		LEVEL FLIGHT AT SEA LEVEL			3629 KG	MID CG		
	PHI	THETA	PSI	ALPHA	BETA	GAMMA	ØMR	B1S	A1S	ØTR
	-1.01	3.98	0.00	-176.02	0.07	180.00	14.17	-1.77	-1.11	5.65
	IDOT	ZDOT	UØ	VØ	WØ	VTO				
	-5.14	0.00	-5.13	0.01	-0.36	5.14				
	U	W	Q	V	P	R	DC	DB	DA	DP
X	-0.0345	0.0221	0.2577	-0.0059	-0.4201	-0.0932	0.0791	0.1283	-0.0006	0.0062
Z	0.2192	-0.3993	-0.4006	-0.0453	-0.0435	0.6401	-1.1329	-0.0300	-0.0011	0.0036
M	0.0184	-0.0110	-0.2796	0.0037	0.2253	0.0465	0.0009	-0.0664	0.0004	0.0104
Y	0.0030	-0.0122	-0.4159	-0.0438	-0.3232	0.2641	-0.0355	-0.0012	0.1049	0.1918
L'	0.0229	-0.0285	-0.8770	-0.0419	-0.6428	0.1469	-0.0475	-0.0021	0.2199	0.1626
N'	0.0304	-0.0150	0.0244	0.0695	-0.1760	-0.7148	0.1585	-0.0005	0.0340	-0.4614

TABLE V-3 CONTINUED
UH-1H STABILITY AND CONTROL DERIVATIVES -- SI UNITS
(BODY-FIXED FRL AXIS SYSTEM)

CASE 122		1 KT		LEVEL FLIGHT AT SEA LEVEL			1629 KG	MID CG		
PHI	THETA	PSI	ALPHA	BETA	GAMMA	ΘMR	B1S	A1S	ΘTR	
-1.07	4.04	0.00	4.04	-0.08	0.00	14.51	-0.90	-1.60	6.44	
	XDOT	ZDOT	UO	VO	WO		VT0			
	0.51	0.00	0.51	-0.00	0.04		0.51			
	U	W	Q	V	P	R	DC	DB	DA	DP
X	-0.0034	0.0250	0.1767	-0.0077	-0.4225	-0.0777	0.0817	0.1249	-0.0009	-0.0007
Z	-0.0991	-0.3850	0.0888	-0.0982	-0.1209	0.6745	-1.1729	0.0386	0.0036	0.0084
H	0.0062	-0.0124	-0.1900	0.0044	0.2342	0.0385	-0.0013	-0.0666	0.0004	0.0062
Y	0.0150	-0.0040	-0.4071	-0.0451	-0.2670	0.2678	-0.0348	0.0017	0.1061	0.1959
L*	0.0253	-0.0162	-0.8779	-0.0417	-0.5720	0.1391	-0.0443	0.0033	0.2217	0.1666
M*	-0.0054	-0.0206	-0.0597	0.0687	-0.3176	-0.7094	0.1718	-0.0004	0.0326	-0.4712

CASE 123		10 KT		LEVEL FLIGHT AT SEA LEVEL			3629 KG	MID CG		
PHI	THETA	PSI	ALPHA	BETA	GAMMA	ΘMR	B1S	A1S	ΘTR	
-0.99	3.95	0.00	3.95	-0.07	0.00	14.15	-0.68	-1.78	5.74	
	XDOT	ZDOT	UO	VO	WO		VT0			
	5.14	0.00	5.13	-0.01	0.35		5.14			
	U	W	Q	V	P	R	DC	DB	DA	DP
X	-0.0036	0.0300	0.2490	-0.0056	-0.4154	-0.0795	0.0741	0.1236	-0.0007	-0.0025
Z	-0.1841	-0.4456	0.3393	-0.0512	-0.1812	0.6229	-1.1351	0.0594	0.0010	-0.0034
H	0.0062	-0.0091	-0.2695	0.0066	0.2333	0.0250	0.0027	-0.0673	0.0003	0.0001
Y	0.0149	-0.0016	-0.4157	-0.0544	-0.3341	0.2726	-0.0270	0.0027	0.1062	0.1927
L*	0.0195	-0.0116	-0.8566	-0.0396	-0.6855	0.1429	-0.0309	0.0054	0.2216	0.1625
M*	-0.0184	-0.0204	0.0274	0.0692	-0.3037	-0.7329	0.1570	0.0011	0.0318	-0.4636

CASE 124		20 KT		LEVEL FLIGHT AT SEA LEVEL			3629 KG	MID CG		
PHI	THETA	PSI	ALPHA	BETA	GAMMA	ΘMR	B1S	A1S	ΘTR	
-0.86	3.70	0.00	3.70	-0.06	0.00	13.57	-0.47	-1.79	4.59	
	XDOT	ZDOT	UO	VO	WO		VT0			
	10.29	0.00	10.27	-0.01	0.66		10.29			
	U	W	Q	V	P	R	DC	DB	DA	DP
X	-0.0046	0.0380	0.3259	-0.0045	-0.4020	-0.0730	0.0676	0.1221	-0.0001	-0.0016
Z	-0.1978	-0.5667	0.3570	-0.0378	-0.2149	0.5683	-1.1151	0.1055	0.0039	0.0035
H	0.0039	-0.0029	-0.2947	0.0070	0.2266	0.0148	0.0062	-0.0682	-0.0000	-0.0035
Y	0.0133	-0.0014	-0.4076	-0.0654	-0.4093	0.2674	-0.0170	0.0049	0.1067	0.1692
L*	0.0127	-0.0100	-0.8152	-0.0397	-0.8210	0.1442	-0.0129	0.0106	0.2227	0.1430
M*	-0.0285	-0.0232	0.1064	0.0709	-0.2786	-0.7396	0.1390	0.0059	0.0326	-0.4070

TABLE V-3 CONTINUED
UH-1H STABILITY AND CONTROL DERIVATIVES -- SI UNITS
(BODY-FIXED FRL AXIS SYSTEM)

CASE 125		90 KT		LEVEL FLIGHT AT SEA LEVEL			3629 KG	MID CG		
	PHI	THETA	PSI	ALPHA	BETA	GAMMA	QMR	B1S	A1S	QTR
	-0.68	4.15	0.00	4.15	-0.05	0.00	12.76	0.73	-1.63	2.71
	XDOT	ZDOT	U0	V0	W0	VT0				
	20.58	0.00	20.52	-0.02	1.49	20.58				
	U	W	Q	V	P	R	DC	DB	DA	DP
X	-0.0144	0.0545	0.4243	-0.0003	-0.3800	-0.0812	0.0841	0.1113	-0.0015	-0.0033
Z	-0.0668	-0.7689	-0.0969	-0.0262	-0.3615	0.5508	-1.2403	0.2072	0.0000	-0.0064
M	0.0083	-0.0060	-0.4184	0.0047	0.2138	0.0088	0.0072	-0.0681	0.0007	-0.0079
Y	0.0070	-0.0023	-0.3944	-0.0942	-0.5223	0.3658	-0.0090	0.0037	0.1051	0.1917
L'	0.0055	-0.0122	-0.7981	-0.0474	-1.0403	0.2255	-0.0021	0.0092	0.2193	0.1626
M'	-0.0194	-0.0381	0.0279	0.0902	-0.2508	-1.0228	0.1027	0.0120	0.0307	-0.4614

CASE 126		60 KT		LEVEL FLIGHT AT SEA LEVEL			3629 KG	MID CG		
	PHI	THETA	PSI	ALPHA	BETA	GAMMA	QMR	B1S	A1S	QTR
	-0.65	3.91	0.00	3.91	-0.04	0.00	12.58	1.72	-1.50	2.10
	XDOT	ZDOT	U0	V0	W0	VT0				
	30.87	0.00	30.79	-0.02	2.10	30.87				
	U	W	Q	V	P	R	DC	DB	DA	DP
X	-0.0244	0.0665	0.4981	0.0022	-0.3545	-0.0829	0.0970	0.1003	-0.0018	-0.0067
Z	0.0123	-0.8757	-0.4929	-0.0235	-0.5291	0.5848	-1.3829	0.3382	-0.0012	-0.0046
M	0.0106	-0.0088	-0.5230	0.0030	0.2043	0.0131	0.0049	-0.0686	0.0007	-0.0054
Y	0.0010	-0.0056	-0.3787	-0.1248	-0.5765	0.4629	-0.0096	0.0060	0.1051	0.2338
L'	-0.0027	-0.0200	-0.7735	-0.0524	-1.1266	0.2915	-0.0064	0.0158	0.2194	0.1992
M'	-0.0093	-0.0490	-0.0281	0.1099	-0.1946	-1.2827	0.0826	0.0226	0.0311	-0.5625

CASE 127		80 KT		LEVEL FLIGHT AT SEA LEVEL			3629 KG	MID CG		
	PHI	THETA	PSI	ALPHA	BETA	GAMMA	QMR	B1S	A1S	QTR
	-0.73	3.56	0.00	3.56	-0.05	0.00	12.81	2.95	-1.49	2.07
	XDOT	ZDOT	U0	V0	W0	VT0				
	41.16	0.00	41.08	-0.03	2.56	41.16				
	U	W	Q	V	P	R	DC	DB	DA	DP
X	-0.0340	0.0788	0.5267	0.0041	-0.3332	-0.0917	0.1141	0.0849	-0.0025	-0.0096
Z	0.0571	-0.9464	-0.8209	-0.0242	-0.7223	0.6116	-1.4946	0.4712	-0.0051	-0.0130
M	0.0131	-0.0142	-0.6126	0.0017	0.1967	0.0192	-0.0001	-0.0683	0.0008	-0.0036
Y	0.0020	-0.0115	-0.3763	-0.1514	-0.5926	0.5423	-0.0179	0.0090	0.1054	0.2692
L'	0.0012	-0.0324	-0.7824	-0.0556	-1.1435	0.3434	-0.0248	0.0227	0.2200	0.2295
M'	-0.0026	-0.0527	-0.1171	0.1212	-0.1555	-1.4981	0.0746	0.0290	0.0305	-0.6475

TABLE V-3 CONTINUED
UH-1H STABILITY AND CONTROL DERIVATIVES -- SI UNITS
(BODY-FIXED FRL AXIS SYSTEM)

CASE 128 100 KT LEVEL FLIGHT AT SEA LEVEL 3629 KG MID CG

	PHI	THETA	PSI	ALPHA	BETA	GAMMA	ΘHR	B1S	A1S	ΘTR
	-0.94	3.02	0.00	3.02	-0.05	0.00	13.42	4.46	-1.74	2.41
	IDOT	ZDOT	U0	V0	W0	VT0				
	51.44	0.00	51.37	-0.04	2.71	51.44				
	U	W	Q	V	P	R	DC	DB	DA	DP
X	-0.0451	0.0925	0.5403	0.0063	-0.3005	-0.0963	0.1368	0.0668	-0.0022	-0.0171
Z	0.0888	-0.9963	-1.0513	-0.0285	-0.9070	0.6602	-1.5753	0.6089	-0.0034	-0.0064
H	0.0166	-0.0218	-0.7012	0.0010	0.1838	0.0173	-0.0088	-0.0680	0.0006	-0.0005
Y	0.0038	-0.0195	-0.3702	-0.1815	-0.5688	0.6159	-0.0305	0.0170	0.1082	0.2980
L'	0.0059	-0.0483	-0.7883	-0.0585	-1.0889	0.3945	-0.0495	0.0392	0.2257	0.2545
N'	0.0031	-0.0485	-0.2407	0.1325	-0.1554	-1.7052	0.0828	0.0322	0.0317	-0.7158

CASE 129 120 KT LEVEL FLIGHT AT SEA LEVEL 3629 KG MID CG

	PHI	THETA	PSI	ALPHA	BETA	GAMMA	ΘHR	B1S	A1S	ΘTR
	-1.29	2.22	0.00	2.22	-0.05	0.00	14.46	6.23	-2.22	3.03
	IDOT	ZDOT	U0	V0	W0	VT0				
	61.73	0.00	61.69	-0.05	2.39	61.73				
	U	W	Q	V	P	R	DC	DB	DA	DP
X	-0.0565	0.1053	0.5229	0.0099	-0.2550	-0.1164	0.1611	0.0452	-0.0028	-0.0322
Z	0.1155	-1.0305	-1.2224	-0.0373	-1.1044	0.7217	-1.6352	0.7405	-0.0026	-0.0037
H	0.0199	-0.0304	-0.7778	-0.0002	0.1588	0.0199	-0.0190	-0.0683	0.0007	0.0116
Y	0.0068	-0.0307	-0.3718	-0.2096	-0.5284	0.6859	-0.0520	0.0283	0.1103	0.3262
L'	0.0117	-0.0692	-0.8030	-0.0611	-1.0047	0.4489	-0.0883	0.0629	0.2312	0.2802
N'	0.0044	-0.0354	-0.3493	0.1396	-0.1782	-1.8854	0.1107	0.0301	0.0347	-0.7818

CASE 130 130 KT LEVEL FLIGHT AT SEA LEVEL 3629 KG MID CG

	PHI	THETA	PSI	ALPHA	BETA	GAMMA	ΘHR	B1S	A1S	ΘTR
	-1.51	1.69	0.00	1.69	-0.04	0.00	15.15	7.21	-2.55	3.46
	IDOT	ZDOT	U0	V0	W0	VT0				
	66.88	0.00	66.85	-0.05	1.98	66.88				
	U	W	Q	V	P	R	DC	DB	DA	DP
X	-0.0622	0.1089	0.5043	0.0114	-0.2365	-0.1291	0.1707	0.0353	-0.0028	-0.0410
Z	0.1266	-1.0373	-1.3131	-0.0422	-1.1853	0.7656	-1.6602	0.8001	-0.0014	-0.0026
H	0.0215	-0.0340	-0.8135	-0.0006	0.1498	0.0228	-0.0238	-0.0699	0.0006	0.0160
Y	0.0078	-0.0366	-0.3774	-0.2234	-0.4966	0.7182	-0.0647	0.0351	0.1126	0.3349
L'	0.0133	-0.0796	-0.8205	-0.0617	-0.9195	0.4743	-0.1108	0.0757	0.2360	0.2883
N'	0.0030	-0.0247	-0.4014	0.1421	-0.1887	-1.9741	0.1329	0.0229	0.0358	-0.8018

TABLE V-3 CONTINUED
UH-IH STABILITY AND CONTROL DERIVATIVES -- SI UNITS
(BODY-FIXED FRL AXIS SYSTEM)

CASE 131	22 KT		11 M/S		SEA LEVEL		3629 KG		MID CG	
	PHI	THETA	PSI	ALPHA	BETA	GAMMA	ΘHR	B1S	A1S	ΘTR
	-1.78	7.26	0.00	-82.73	1.76	90.00	16.97	2.28	-2.57	8.37
	IDOT	ZDOT	UO	VO	WO	VT0				
	0.00	-11.06	1.40	0.34	-10.97	11.06				
	U	W	Q	V	P	R	DC	DB	DA	DP
X	-0.0140	0.0645	-0.8170*	-0.0013	-0.3915	-0.1617	0.1593	0.1303	-0.0017	-0.0099
Z	0.0059	-0.5336	-1.3102	-0.0941	-0.2447	0.8477	-1.2124	0.0378	0.0070	0.0117
H	0.0113	-0.0465	-1.7509	0.0016	0.2086	0.2280	-0.0358	-0.0691	0.0007	0.0321
Y	0.0110	-0.0355	-0.5411	-0.0659	-0.1070	0.4046	-0.0598	0.0017	0.1122	0.2102
L'	0.0201	-0.0535	-0.3754	-0.0590	-0.2191	0.2495	-0.0811	0.0032	0.2346	0.1820
H'	-0.0014	0.0616	-0.3835	0.1041	-0.3248	-0.9932	0.2598	-0.0017	0.0339	-0.5047

CASE 132	60 KT		12 M/S		SEA LEVEL		3629 KG		MID CG	
	PHI	THETA	PSI	ALPHA	BETA	GAMMA	ΘHR	B1S	A1S	ΘTR
	-1.62	3.10	0.00	-20.52	0.57	23.64	16.94	1.81	-3.15	6.14
	IDOT	ZDOT	UO	VO	WO	VT0				
	28.28	-12.37	28.91	0.31	-10.82	30.87				
	U	W	Q	V	P	R	DC	DB	DA	DP
X	-0.0321	0.0585	-0.1614	0.0052	-0.3599	-0.1230	0.0846	0.1194	-0.0018	-0.0199
Z	0.0295	-0.8181	-0.5243	-0.0499	-0.5480	0.9431	-1.3784	0.3070	0.0090	-0.0008
H	-0.0111	-0.0452	-0.3519	0.0107	0.1993	-0.0016	0.0090	-0.0756	0.0004	0.0065
Y	0.0069	-0.0311	-0.4515	-0.1315	-0.2052	0.5763	-0.0533	0.0131	0.1176	0.2269
L'	0.0038	-0.0519	-0.8635	-0.0411	-0.3903	0.3661	-0.0662	0.0248	0.2454	0.1965
H'	-0.0281	0.0482	0.1512	0.1284	-0.3290	-1.4687	0.2660	-0.0106	0.0339	-0.5445

CASE 133	100 KT		10 M/S		SEA LEVEL		3629 KG		MID CG	
	PHI	THETA	PSI	ALPHA	BETA	GAMMA	ΘHR	B1S	A1S	ΘTR
	-1.66	4.42	0.00	-6.44	0.19	10.86	16.79	5.94	-2.98	4.87
	IDOT	ZDOT	UO	VO	WO	VT0				
	50.52	-9.69	51.12	0.17	-5.77	51.44				
	U	W	Q	V	P	R	DC	DB	DA	DP
X	-0.0516	0.0853	0.2706	0.0117	-0.2881	-0.1629	0.1507	0.0790	-0.0027	-0.0337
Z	0.1091	-0.9613	-1.2183	-0.0481	-0.9513	0.9362	-1.5265	0.5776	0.0049	-0.0011
H	0.0203	-0.0285	-0.6133	0.0005	0.1728	0.0419	-0.0147	-0.0759	0.0006	0.0165
Y	0.0088	-0.0375	-0.4262	-0.1897	-0.3329	0.6745	-0.0653	0.0285	0.1223	0.2842
L'	0.0115	-0.0744	-0.8958	-0.0476	-0.6265	0.4635	-0.0962	0.0556	0.2548	0.2462
H'	-0.0143	0.0238	-0.2884	0.1359	-0.2376	-1.8083	0.2375	-0.0127	0.0350	-0.6807

*This derivative was transcribed accurately from the original source but exceeds the usual range of values and should be used with due caution.

TABLE V-3 CONTINUED
UH-IH STABILITY AND CONTROL DERIVATIVES-- SI UNITS
(BODY-FIXED FRL AXIS SYSTEM)

CASE 134		60 KT	-8 M/S	SEA LEVEL	3629 KG	MID CG				
	PHI	THETA	PSI	ALPHA	BETA	GAMMA	ΘMR	B1S	A1S	ΘTR
	-0.01	3.14	0.00	18.37	-0.00	-15.23	9.64	0.09	-0.51	0.07
	XDOT	ZDOT	U0	V0	W0	VTO				
	29.78	8.11	29.29	-0.00	9.73	30.87				
	U	W	Q	V	P	R	DC	DB	DA	DP
X	-0.0179	0.0569	0.7629	0.0001	-0.3628	-0.0501	0.0658	0.1015	-0.0007	-0.0015
Z	-0.0201	-0.8066	-0.5012	-0.0076	-0.3814	0.3641	-1.3354	0.3098	0.0013	0.0063
M	0.0149	-0.0488	-0.6268	-0.0011	0.2055	0.0197	0.0175	-0.0668	0.0003	-0.0009
Y	-0.0033	0.0107	-0.3517	-0.1165	-0.7869	0.4420	0.0180	0.0016	0.0991	0.2458
L'	-0.0063	0.0071	-0.6970	-0.0594	-1.5345	0.2651	0.0327	0.0101	0.2073	0.2083
M'	0.0015	-0.0933	0.1372	0.1100	-0.0801	-1.2678	-0.0261	0.0427	0.0305	-0.5916
CASE 135		100 KT	-15 M/S	SEA LEVEL	3629 KG	MID CG				
	PHI	THETA	PSI	ALPHA	BETA	GAMMA	ΘMR	B1S	A1S	ΘTR
	0.22	1.34	0.00	18.26	0.07	-16.91	7.47	-0.08	0.10	-0.32
	XDOT	ZDOT	U0	V0	W0	VTO				
	49.22	14.97	48.85	0.06	16.12	51.44				
	U	W	Q	V	P	R	DC	DB	DA	DP
X	-0.0295	0.0613	0.9717	0.0008	-0.3483	-0.0115	0.0519	0.0811	-0.0019	0.0009
Z	0.0163	-0.8916	-1.1721	0.0019	-0.5882	0.2378	-1.4981	0.5348	-0.0012	-0.0016
M	0.0226	-0.0706	-0.8871	-0.0028	0.2041	0.0052	0.0310	-0.0675	0.0005	-0.0030
Y	-0.0029	0.0146	-0.3326	-0.1660	-0.9247	0.5702	0.0245	-0.0051	0.0900	0.3187
L'	-0.0014	0.0079	-0.6553	-0.0670	-1.7880	0.3306	0.0260	0.0039	0.1876	0.2697
M'	0.0192	-0.1387	0.1548	0.1305	0.0076	-1.6545	-0.1518	0.0943	0.0264	-0.7670
CASE 136		6 KT	-3 M/S	SEA LEVEL	3629 KG	MID CG				
	PHI	THETA	PSI	ALPHA	BETA	GAMMA	ΘMR	B1S	A1S	ΘTR
	-0.90	3.56	0.00	93.56	-0.90	-90.00	13.99	-1.45	-1.33	5.56
	XDOT	ZDOT	U0	V0	W0	VTO				
	0.00	3.05	-0.19	-0.05	3.04	3.05				
	U	W	Q	V	P	R	DC	DB	DA	DP
X	-0.0098	0.0189	0.2784	-0.0135	-0.4270	-0.0844	0.0713	0.1240	-0.0006	0.0016
Z	-0.0840	-0.3317	-0.0049	-0.1021	-0.0994	0.6357	-1.1731	0.0327	0.0014	0.0020
M	0.0117	-0.0137	-0.2929	0.0039	0.2355	0.0369	0.0023	-0.0660	0.0003	0.0000
Y	0.0176	0.0036	-0.3496	-0.0434	-0.3327	0.2591	-0.0289	0.0017	0.1053	0.1920
L'	0.0277	-0.0062	-0.8021	-0.0405	-0.6748	0.1332	-0.0352	0.0029	0.2196	0.1623
M'	-0.0051	-0.0374	-0.1137	0.0688	-0.2295	-0.7042	0.1542	-0.0015	0.0315	-0.4621

TABLE V-3 CONTINUED
UH-1H STABILITY AND CONTROL DERIVATIVES -- SI UNITS
(BODY-FIXED FRL AXIS SYSTEM)

CASE 137		12 KT		-6 M/S		SEA LEVEL		3629 KG		MID CG	
	PHI	THETA	PSI	ALPHA	BETA	GAMMA	ΘHR	B1S	A1S	ΘTR	
	-0.75	3.07	0.00	93.07	-0.74	-90.00	13.52	-1.93	-1.13	4.58	
	XDOT	ZDOT	UO	VO	WO	VT0					
	0.00	6.10	-0.33	-0.08	6.09	6.10					
	U	W	Q	V	P	R	DC	DB	DA	DP	
X	-0.0065	0.0140	0.2965	-0.0138	-0.4319	-0.0731	0.0606	0.1230	-0.0005	0.0031	
Z	-0.1137	-0.2920	0.0557	-0.1012	-0.0693	0.6082	-1.1671	0.0321	-0.0006	-0.0044	
H	0.0124	-0.0130	-0.3080	0.0058	0.2361	0.0406	0.0062	-0.0656	0.0003	-0.0051	
Y	0.0173	0.0076	-0.3226	-0.0425	-0.3710	0.2276	-0.0238	0.0021	0.1045	0.1918	
L*	0.0303	-0.0000	-0.7647	-0.0390	-0.7306	0.1103	-0.0273	0.0031	0.2176	0.1615	
N*	-0.0000	-0.0423	-0.0904	0.0711	-0.1688	-0.6275	0.1397	-0.0024	0.0304	-0.4619	

CASE 138		6 KT		3 M/S		SEA LEVEL		3629 KG		MID CG	
	PHI	THETA	PSI	ALPHA	BETA	GAMMA	ΘHR	B1S	A1S	ΘTR	
	-1.25	4.68	0.00	-85.31	1.25	90.00	15.13	-0.32	-1.82	7.04	
	XDOT	ZDOT	UO	VO	WO	VT0					
	0.00	-3.05	0.25	0.07	-3.04	3.05					
	U	W	Q	V	P	R	DC	DB	DA	DP	
X	-0.0132	0.0326	-0.1927	-0.0118	-0.4149	-0.0970	0.0970	0.1262	-0.0009	-0.0027	
Z	-0.0377	-0.4181	-0.0881	-0.1002	-0.1605	0.7095	-1.1771	0.0324	0.0026	0.0061	
H	0.0091	-0.0216	-0.2849	0.0022	0.2329	0.0360	-0.0074	-0.0671	0.0004	0.0140	
Y	0.0124	-0.0204	-0.5229	-0.0505	-0.2335	0.2933	-0.0407	0.0016	0.1075	0.1988	
L*	0.0234	-0.0325	-0.9826	-0.0467	-0.4886	0.1602	-0.0531	0.0031	0.2246	0.1698	
N*	0.0005	0.0193	0.0976	0.0780	-0.3023	-0.7611	0.1922	-0.0010	0.0329	-0.4779	

CASE 139		12 KT		6 M/S		SEA LEVEL		3629 KG		MID CG	
	PHI	THETA	PSI	ALPHA	BETA	GAMMA	ΘHR	B1S	A1S	ΘTR	
	-1.44	5.50	0.00	-84.50	1.43	90.00	15.78	0.50	-2.09	7.53	
	XDOT	ZDOT	UO	VO	WO	VT0					
	0.00	-6.10	0.58	0.15	-6.07	6.10					
	U	W	Q	V	P	R	DC	DB	DA	DP	
X	-0.0157	0.0427	0.1414	-0.0105	-0.4073	-0.1176	0.1164	0.1276	-0.0010	-0.0053	
Z	-0.0203	-0.4615	-0.1074	-0.0999	-0.1902	0.7588	-1.1896	0.0340	0.0042	0.0089	
H	0.0094	-0.0313	-0.2982	0.0013	0.2221	0.0388	-0.0157	-0.0679	0.0004	0.0207	
Y	0.0120	-0.0263	-0.5377	-0.0557	-0.1931	0.3305	-0.0474	0.0014	0.1092	0.2032	
L*	0.0215	-0.0406	-1.0160	-0.0510	-0.3952	0.1907	-0.0631	0.0026	0.2282	0.1744	
N*	-0.0006	0.0350	-0.0035	0.0866	-0.2947	-0.8380	0.2153	-0.0011	0.0336	-0.4883	

TABLE V-3 CONTINUED
 UH-IH STABILITY AND CONTROL DERIVATIVES-- SI UNITS
 (BODY-FIXED FRL AXIS SYSTEM)

CASE 140	60 KT		6 M/S		SEA LEVEL		3629 KG		MID CG	
	PHI	THETA	PSI	ALPHA	BETA	GAMMA	ØMR	B1S	A1S	ØTR
	-0.85	4.60	-1.13	-6.78	1.21	11.39	14.72	2.57	-2.30	4.12
	XDOT		ZDOT		ØØ		VØ		WØ	
	30.26		-6.10		30.64		0.65		-3.64	
	VTØ		U		W		Q		V	
	30.87									
	P		R		DC		DB		DA	
X	-0.0255	0.0754	0.3663	0.0065	-0.3489	-0.1123	0.1069	0.1060	-0.0023	-0.0112
Z	0.0291	-0.8658	-0.5662	-0.0376	-0.5742	0.7489	-1.3841	0.3295	0.0061	-0.0096
H	0.0116	-0.0186	-0.4903	0.0039	0.1990	0.0051	0.0021	-0.0720	0.0006	-0.0063
Y	0.0039	-0.0172	-0.4030	-0.1310	-0.4080	0.5034	-0.0322	0.0101	0.1117	0.2305
L'	0.0017	-0.0391	-0.8304	-0.0437	-0.7994	0.3247	-0.0381	0.0212	0.2333	0.1967
H'	-0.0194	-0.0052	-0.0836	0.1143	-0.2767	-1.3486	0.1693	0.0057	0.0328	-0.5544

CASE 141	60 KT		3 M/S		SEA LEVEL		3629 KG		MID CG	
	PHI	THETA	PSI	ALPHA	BETA	GAMMA	ØMR	B1S	A1S	ØTR
	-0.89	4.20	0.00	-1.47	0.02	5.67	13.65	2.09	-1.90	2.98
	XDOT		ZDOT		ØØ		VØ		WØ	
	30.72		-3.05		30.86		0.01		-0.79	
	VTØ		U		W		Q		V	
	30.87									
	P		R		DC		DB		DA	
X	-0.0262	0.0656	0.3898	0.0030	-0.3552	-0.0976	0.1030	0.1022	-0.0019	-0.0092
Z	0.0199	-0.8727	-0.5242	-0.0296	-0.5494	0.6695	-1.3847	0.3358	-0.0004	-0.0067
H	0.0115	-0.0109	-0.4883	0.0037	0.2046	0.0105	0.0035	-0.0700	0.0007	-0.0051
Y	0.0029	-0.0114	-0.3909	-0.1273	-0.4907	0.4796	-0.0195	0.0078	0.1083	0.2315
L'	-0.0010	-0.0283	-0.7929	-0.0477	-0.9569	0.3074	-0.0197	0.0180	0.2261	0.1976
H'	-0.0143	-0.0266	-0.0311	0.1116	-0.2212	-1.3072	0.1265	0.0138	0.0318	-0.5569

CASE 142	60 KT		-3 M/S		SEA LEVEL		3629 KG		MID CG	
	PHI	THETA	PSI	ALPHA	BETA	GAMMA	ØMR	B1S	A1S	ØTR
	-0.32	3.70	-0.40	9.37	0.35	-5.67	11.48	1.31	-1.09	1.34
	XDOT		ZDOT		ØØ		VØ		WØ	
	30.72		3.05		30.45		0.19		5.02	
	VTØ		U		W		Q		V	
	30.87									
	P		R		DC		DB		DA	
X	-0.0225	0.0679	0.5977	0.0022	-0.3611	-0.0702	0.0899	0.0985	-0.0020	-0.0033
Z	0.0046	-0.8613	-0.5040	-0.0178	-0.4704	0.4974	-1.3724	0.3306	0.0000	-0.0051
H	0.0096	-0.0090	-0.5577	0.0023	0.2066	0.0167	0.0070	-0.0669	0.0008	-0.0052
Y	-0.0015	0.0021	-0.3709	-0.1228	-0.6600	0.4491	0.0011	0.0027	0.1017	0.2372
L'	-0.0046	-0.0076	-0.7589	-0.0569	-1.2887	0.2756	0.0091	0.0102	0.2126	0.2016
H'	-0.0045	-0.0683	-0.0083	0.1089	-0.1481	-1.2674	0.0406	0.0303	0.0305	-0.5709

TABLE V-3 CONTINUED
UH-IH STABILITY AND CONTROL DERIVATIVES -- SI UNITS
(BODY-FIXED FRL AXIS SYSTEM)

CASE 143		60 KT	-6 M/S	SEA LEVEL	3629 KG	MID CG				
	PHI	THETA	PSI	ALPHA	BETA	GAMMA	ΘMR	B1S	A1S	ΘTR
	-0.17	3.53	0.00	14.92	-0.04	-11.39	10.37	0.79	-0.74	0.53
	XDOT	ZDOT	UO	VO	WO	VTO				
	30.26	6.10	29.83	-0.02	7.95	30.87				
	U	W	Q	V	P	R	DC	DB	DA	DP
X	-0.0203	0.0672	0.6987	0.0007	-0.3646	-0.0571	0.0807	0.0984	-0.0014	-0.0021
Z	-0.0057	-0.8364	-0.5231	-0.0118	-0.4230	0.4176	-1.3511	0.3179	-0.0003	0.0011
H	0.0086	-0.0200	-0.5973	0.0016	0.2078	0.0197	0.0104	-0.0659	0.0006	-0.0028
Y	-0.0026	0.0077	-0.3633	-0.1213	-0.7363	0.4428	0.0114	0.0015	0.0997	0.2413
L'	-0.0061	0.0022	-0.7367	-0.0596	-1.4369	0.2693	0.0234	0.0088	0.2084	0.2049
M'	-0.0003	-0.0841	0.0371	0.1090	-0.1088	-1.2603	-0.0001	0.0375	0.0302	-0.5807

CASE 144		0 KT	LEVEL FLIGHT	3048 M	3629 KG	MID CG				
	PHI	THETA	PSI	ALPHA	BETA	GAMMA	ΘMR	B1S	A1S	ΘTR
	-1.22	4.12	0.00	4.12	-0.09	0.00	16.10	-0.89	-1.74	8.54
	XDOT	ZDOT	UO	VO	WO	VTO				
	0.00	0.00	0.00	0.00	0.00	0.00				
	U	W	Q	V	P	R	DC	DB	DA	DP
X	-0.0154	0.0178	0.3717	-0.0016	-0.3976	-0.0797	0.0643	0.1282	-0.0006	-0.0002
Z	-0.0395	-0.2859	0.0390	-0.0711	-0.0662	0.6850	-0.9008	0.0299	0.0010	0.0023
H	0.0091	-0.0164	-0.3361	-0.0031	0.2125	0.0365	-0.0019	-0.0681	0.0003	0.0069
Y	0.0159	-0.0046	-0.3665	-0.0280	-0.3830	0.2098	-0.0300	0.0012	0.1085	0.1567
L'	0.0311	-0.0145	-0.7510	-0.0135	-0.8090	0.0838	-0.0343	0.0025	0.2269	0.1334
M'	0.0020	-0.0144	0.0016	0.0621	-0.3646	-0.6399	0.1724	-0.0001	0.0340	-0.3770

CASE 145		60 KT	LEVEL FLIGHT	3048 M	3629 KG	MID CG				
	PHI	THETA	PSI	ALPHA	BETA	GAMMA	ΘMR	B1S	A1S	ΘTR
	-0.71	3.98	0.00	3.98	-0.05	0.00	13.95	2.00	-1.78	3.09
	XDOT	ZDOT	UO	VO	WO	VTO				
	30.87	0.00	30.79	-0.03	2.14	30.87				
	U	W	Q	V	P	R	DC	DB	DA	DP
X	-0.0230	0.0382	0.6453	-0.0002	-0.3724	-0.0747	0.0534	0.1124	-0.0016	-0.0070
Z	-0.0085	-0.6122	-0.5647	-0.0195	-0.3433	0.5919	-0.9840	0.2436	0.0012	-0.0041
H	0.0110	-0.0028	-0.5282	0.0042	0.2036	0.0055	0.0125	-0.0708	0.0006	-0.0055
Y	0.0001	-0.0024	-0.3545	-0.0978	-0.6912	0.3249	-0.0055	0.0056	0.1066	0.1728
L'	-0.0051	-0.0120	-0.7009	-0.0502	-1.4081	0.1639	0.0049	0.0143	0.2226	0.1469
M'	-0.0104	-0.0394	0.1157	0.0793	-0.3543	-1.0220	0.1023	0.0197	0.0319	-0.4156

TABLE V-3 CONTINUED
UH-1H STABILITY AND CONTROL DERIVATIVES -- SI UNITS
(BODY-FIXED FRL AXIS SYSTEM)

CASE 146		100 KT		LEVEL FLIGHT		3048 M		3629 KG		MID CG	
	PHI	THETA	PSI	ALPHA	BETA	GAMMA	ΘMR	B1S	A1S	ΘTR	
	-0.97	3.28	0.00	3.28	-0.06	0.00	14.61	4.72	-1.87	3.33	
	XDOT	ZDOT	U0	V0	W0	VT0					
	51.44	0.00	51.36	-0.05	2.94	51.44					
	U	W	Q	V	P	R	DC	DB	DA	DP	
X	-0.0373	0.0463	0.7430	0.0041	-0.3365	-0.0913	0.0598	0.0963	-0.0022	-0.0209	
Z	0.0548	-0.6733	-1.2155	-0.0201	-0.5456	0.6349	-1.0679	0.4209	-0.0003	-0.0022	
H	0.0148	-0.0075	-0.6820	0.0018	0.1843	0.0177	0.0114	-0.0743	0.0007	0.0091	
Y	0.0030	-0.0129	-0.3472	-0.1398	-0.6745	0.4422	-0.0222	0.0136	0.1088	0.2227	
L'	0.0034	-0.0334	-0.7113	-0.0558	-1.3528	0.2452	-0.0307	0.0319	0.2267	0.1914	
N'	0.0001	-0.0393	-0.0502	0.0951	-0.2899	-1.3524	0.0953	0.0297	0.0317	-0.5338	

CASE 147		20 KT		10 M/S		3048 M		3629 KG		MID CG	
	PHI	THETA	PSI	ALPHA	BETA	GAMMA	ΘMR	B1S	A1S	ΘTR	
	-1.86	6.62	0.00	-83.38	1.84	90.00	18.29	1.66	-2.65	11.04	
	XDOT	ZDOT	U0	V0	W0	VT0					
	0.00	-10.12	1.17	0.33	-10.05	10.12					
	U	W	Q	V	P	R	DC	DB	DA	DP	
X	-0.0206	0.0427	0.1664	-0.0101	-0.4038	-0.1408	0.1070	0.1297	-0.0026	-0.0110	
Z	-0.0014	-0.3783	-0.0237	-0.0731	-0.2041	0.8179	-0.8880	0.0418	0.0122	0.0318	
H	0.0116	-0.0378	-0.3335	0.0021	0.2106	0.0517	-0.0211	-0.0693	0.0014	0.0303	
Y	0.0130	-0.0249	-0.5176	-0.0563	-0.2196	0.3070	-0.0459	0.0029	0.1132	0.1641	
L'	0.0237	-0.0388	-1.0257	-0.0577	-0.4795	0.1701	-0.0563	0.0059	0.2366	0.1434	
N'	0.0000	0.0392	-0.2456	0.0762	-0.4186	-0.8528	0.2384	-0.0009	0.0339	-0.3930	

CASE 148		60 KT		11 M/S		3048 M		3629 KG		MID CG	
	PHI	THETA	PSI	ALPHA	BETA	GAMMA	ΘMR	B1S	A1S	ΘTR	
	-1.65	2.72	0.00	-17.92	0.51	20.64	17.83	1.63	-3.29	8.15	
	XDOT	ZDOT	U0	V0	W0	VT0					
	28.88	-10.88	29.37	0.27	-9.50	30.87					
	U	W	Q	V	P	R	DC	DB	DA	DP	
X	-0.0301	0.0324	0.3200	0.0027	-0.3640	-0.0964	0.0406	0.1259	-0.0020	-0.0184	
Z	0.0020	-0.5788	-0.7281	-0.0362	-0.3906	0.7919	-0.9569	0.2227	0.0065	-0.0057	
H	0.0017	-0.0115	-0.3679	0.0081	0.1874	-0.0148	0.0155	-0.0756	0.0006	0.0027	
Y	0.0049	-0.0195	-0.4282	-0.1068	-0.2981	0.4085	-0.0358	0.0099	0.1156	0.1608	
L'	-0.0001	-0.0336	-0.8189	-0.0406	-0.6304	0.2275	-0.0335	0.0191	0.2414	0.1381	
N'	-0.0231	0.0346	0.1870	0.0863	-0.4730	-1.1710	0.2466	-0.0067	0.0332	-0.3856	

TABLE V-3 CONTINUED
UH-1H STABILITY AND CONTROL DERIVATIVES -- SI UNITS
(BODY-FIXED FRL AXIS SYSTEM)

CASE 149		60 KT	-8 M/S	3048 M	3629 KG	MID CG				
	PHI	THETA	PSI	ALPHA	BETA	GAMMA	ΘHR	B1S	A1S	ΘTR
	-0.03	3.38	0.00	18.66	-0.01	-15.29	11.08	0.63	-0.80	0.16
	XDOT		ZDOT	U0	V0	W0	VT0			
	29.77		8.14	29.24	-0.01	9.88	30.87			
	U	W	Q	V	P	R	DC	DB	DA	DP
X	-0.0168	0.0340	0.8737	-0.0020	-0.3620	-0.0489	0.0373	0.1120	-0.0008	-0.0012
Z	-0.0350	-0.5680	-0.5680	-0.0088	-0.2671	0.4509	-0.9608	0.2200	0.0035	0.0066
M	0.0142	-0.0349	-0.6159	0.0005	0.2021	0.0167	0.0183	-0.0687	0.0003	-0.0006
Y	-0.0040	0.0088	-0.3374	-0.0901	-0.8745	0.3102	0.0164	0.0024	0.1032	0.1822
L*	-0.0084	0.0068	-0.6555	-0.0528	-1.7581	0.1512	0.0365	0.0102	0.2159	0.1545
M*	-0.0014	-0.0701	0.2162	0.0811	-0.2322	-0.9959	0.0193	0.0336	0.0322	-0.4385

CASE 150		100 KT	-14 M/S	3048 M	3629 KG	MID CG				
	PHI	THETA	PSI	ALPHA	BETA	GAMMA	ΘHR	B1S	A1S	ΘTR
	0.23	2.05	0.00	18.22	0.07	-16.17	9.04	1.12	-0.09	-0.54
	XDOT		ZDOT	U0	V0	W0	VT0			
	49.41		14.33	48.87	0.06	16.08	51.44			
	U	W	Q	V	P	R	DC	DB	DA	DP
X	-0.0263	0.0378	1.0714	-0.0002	-0.3533	-0.0281	0.0238	0.0950	-0.0028	0.0026
Z	0.0097	-0.6167	-1.1209	-0.0008	-0.3963	0.3691	-1.0773	0.3801	-0.0008	-0.0077
M	0.0187	-0.0493	-0.8305	-0.0015	0.2014	0.0104	0.0292	-0.0690	0.0009	-0.0031
Y	-0.0028	0.0100	-0.3349	-0.1273	-0.9997	0.3989	0.0156	-0.0040	0.0945	0.2363
L*	-0.0021	0.0046	-0.6488	-0.0588	-1.9824	0.1856	0.0193	0.0023	0.1969	0.2004
M*	0.0153	-0.1002	0.2285	0.0954	-0.1069	-1.2729	-0.0778	0.0700	0.0271	-0.5690

CASE 151		1 KT	LEVEL FLIGHT AT SEA LEVEL			3629 KG	FWD CG			
	PHI	THETA	PSI	ALPHA	BETA	GAMMA	ΘHR	B1S	A1S	ΘTR
	-1.06	-0.72	0.00	-0.72	0.01	0.00	14.49	-5.55	-1.55	6.40
	XDOT		ZDOT	U0	V0	W0	VT0			
	0.51		0.00	0.51	0.00	-0.01	0.51			
	U	W	Q	V	P	R	DC	DB	DA	DP
X	-0.0131	-0.0061	0.1934	-0.0155	-0.4309	-0.0360	-0.0207	0.1284	-0.0005	-0.0001
Z	-0.1556	-0.3906	0.1144	-0.0951	-0.0478	0.6703	-1.1822	0.0363	0.0008	0.0002
M	0.0064	-0.0130	-0.2647	0.0045	0.2337	0.0248	0.0011	-0.0669	0.0003	0.0060
Y	0.0137	-0.0040	-0.4050	-0.0449	-0.2695	0.2747	-0.0351	0.0020	0.1058	0.1956
L*	0.0220	-0.0160	-0.7328	-0.0403	-0.5732	0.1382	-0.0437	0.0037	0.2186	0.1615
M*	-0.0072	-0.0202	0.8065	0.0701	-0.3131	-0.7169	0.1761	-0.0011	0.0268	-0.4813

TABLE V-3 CONTINUED
UH-IH STABILITY AND CONTROL DERIVATIVES -- SI UNITS
(BODY-FIXED FRL AXIS SYSTEM)

CASE 152		60 KT		LEVEL FLIGHT AT SEA LEVEL				3629 KG		FWD CG	
	PHI	THETA	PSI	ALPHA	BETA	GAMMA	ΘMR	B1S	A1S	ΘTR	
	-0.61	-0.47	0.00	-0.47	0.01	0.00	12.63	-2.57	-1.42	2.05	
	XDOT		ZDOT	U0	V0	W0	VTO				
	30.87		0.00	30.87	0.00	-0.25	30.87				
	U	W	Q	V	P	R	DC	DB	DA	DP	
X	-0.0242	-0.0001	0.4619	0.0004	-0.3976	-0.0276	-0.0136	0.1284	-0.0017	-0.0068	
Z	-0.0445	-0.8792	-0.5537	-0.0217	-0.4453	0.6350	-1.3916	0.3359	-0.0006	-0.0048	
H	0.0118	-0.0139	-0.5528	0.0028	0.2045	0.0099	0.0038	-0.0673	0.0006	-0.0041	
Y	0.0003	-0.0053	-0.3821	-0.1260	-0.5795	0.4827	-0.0092	0.0057	0.1065	0.2333	
L*	-0.0045	-0.0190	-0.6470	-0.0433	-1.1195	0.2891	-0.0053	0.0151	0.2200	0.1940	
H*	-0.0126	-0.0490	0.7753	0.1195	-0.1646	-1.3472	0.0836	0.0228	0.0254	-0.5742	

CASE 153		100 KT		LEVEL FLIGHT AT SEA LEVEL				3629 KG		FWD CG	
	PHI	THETA	PSI	ALPHA	BETA	GAMMA	ΘMR	B1S	A1S	ΘTR	
	-0.89	-0.77	0.00	-0.77	0.01	0.00	13.57	0.78	-1.64	2.40	
	XDOT		ZDOT	U0	V0	W0	VTO				
	51.44		0.00	51.44	0.01	-0.69	51.44				
	U	W	Q	V	P	R	DC	DB	DA	DP	
X	-0.0383	0.0267	0.4897	0.0043	-0.3698	-0.0455	0.0264	0.1132	-0.0023	-0.0171	
Z	0.0375	-1.0009	-1.1327	-0.0267	-0.8208	0.7424	-1.5768	0.6061	-0.0020	-0.0054	
H	0.0189	-0.0332	-0.7558	0.0007	0.1808	0.0212	-0.0185	-0.0625	0.0005	0.0015	
Y	0.0022	-0.0187	-0.3753	-0.1833	-0.5788	0.6420	-0.0288	0.0160	0.1123	0.2973	
L*	0.0023	-0.0465	-0.6833	-0.0457	-1.0959	0.3915	-0.0448	0.0372	0.2316	0.2479	
H*	0.0002	-0.0496	0.4489	0.1463	-0.1252	-1.7941	0.0867	0.0327	0.0265	-0.7304	

CASE 154		1 KT		LEVEL FLIGHT AT SEA LEVEL				3629 KG		AFT CG	
	PHI	THETA	PSI	ALPHA	BETA	GAMMA	ΘMR	B1S	A1S	ΘTR	
	-1.08	8.79	0.00	8.78	-0.17	0.00	14.51	3.74	-1.66	6.49	
	XDOT		ZDOT	U0	V0	W0	VTO				
	0.51		0.00	0.51	-0.00	0.08	0.51				
	U	W	Q	V	P	R	DC	DB	DA	DP	
X	-0.0032	0.0551	0.1806	-0.0491	-0.4007	-0.1543	0.1836	0.1238	-0.0010	-0.0007	
Z	-0.0431	-0.3761	0.0482	0.0224	-0.2092	0.6487	-1.1649	0.0356	0.0017	0.0027	
H	0.0037	-0.0144	-0.2574	0.1762	0.2346	0.0430	-0.0039	-0.0674	0.0004	0.0061	
Y	0.0165	-0.0038	-0.4102	-0.0638	-0.2713	0.2598	-0.0345	0.0015	0.1062	0.1965	
L*	0.0289	-0.0159	-1.0233	0.0575*	-0.5858	0.1340	-0.0445	0.0028	0.2242	0.1714	
H*	-0.0035	-0.0208	-0.9258	0.1205	-0.1269	-0.6840	0.1700	-0.0009	0.0342	-0.4620	

*This derivative was transcribed accurately from the original source but exceeds the usual range of values and should be used with due caution.

TABLE V-3 CONTINUED
UH-1H STABILITY AND CONTROL DERIVATIVES -- SI UNITS
(BODY-FIXED FRL AXIS SYSTEM)

CASE 155		60 KT		LEVEL FLIGHT AT SEA LEVEL			3629 KG	AFT CG		
	PHI	THETA	PSI	ALPHA	BETA	GAMMA	QMR	B1S	A1S	QTR
	-0.69	8.20	0.00	8.20	-0.10	0.00	12.52	6.00	-1.59	2.17
	XDOT		ZDOT	U0	V0	W0	VTO			
	30.87		0.00	30.55	-0.05	4.40	30.87			
	U	W	Q	V	P	R	DC	DB	DA	DP
X	-0.0343	0.1321	0.5292	0.0043	-0.3009	-0.1297	0.2068	0.0728	-0.0018	-0.0067
Z	0.0692	-0.8647	-0.4443	-0.0253	-0.6078	0.5281	-1.3700	0.3406	-0.0018	-0.0048
R	0.0090	-0.0050	-0.5006	0.0031	0.2054	0.0164	0.0057	-0.0704	0.0008	-0.0066
Y	0.0021	-0.0061	-0.3744	-0.1238	-0.5766	0.4446	-0.0104	0.0066	0.1032	0.2343
L'	-0.0002	-0.0214	-0.8978	-0.0610	-1.1412	0.2920	-0.0084	0.0170	0.2180	0.2043
M'	-0.0057	-0.0489	-0.8290	0.1004	-0.2299	-1.2229	0.0816	0.0226	0.0368	-0.5507

CASE 156		100 KT		LEVEL FLIGHT AT SEA LEVEL			3629 KG	AFT CG		
	PHI	THETA	PSI	ALPHA	BETA	GAMMA	QMR	B1S	A1S	QTR
	-1.02	6.69	0.00	6.69	-0.12	0.00	13.33	8.17	-1.88	2.48
	XDOT		ZDOT	U0	V0	W0	VTO			
	51.44		0.00	51.09	-0.11	5.99	51.44			
	U	W	Q	V	P	R	DC	DB	DA	DP
X	-0.0601	0.1580	0.5794	0.0089	-0.2168	-0.1356	0.2489	0.0195	-0.0018	-0.0179
Z	0.1402	-0.9843	-0.9728	-0.0308	-0.9696	0.5760	-1.5655	0.6116	-0.0045	-0.0058
R	0.0134	-0.0126	-0.6556	0.0012	0.1858	0.0146	-0.0003	-0.0735	0.0007	-0.0021
Y	0.0061	-0.0210	-0.3667	-0.1800	-0.5546	0.5914	-0.0334	0.0188	0.1042	0.2987
L'	0.0105	-0.0513	-0.8974	-0.0703	-1.0747	0.3934	-0.0565	0.0429	0.2195	0.2613
M'	0.0053	-0.0464	-0.9365	0.1187	-0.1938	-1.6241	0.0799	0.0316	0.0364	-0.7011

CASE 157		1 KT		LEVEL FLIGHT AT SEA LEVEL			2948 KG	MID CG		
	PHI	THETA	PSI	ALPHA	BETA	GAMMA	QMR	B1S	A1S	QTR
	-1.07	4.24	0.00	4.24	-0.08	0.00	13.62	-0.72	-1.50	5.45
	XDOT		ZDOT	U0	V0	W0	VTO			
	0.51		0.00	0.51	-0.00	0.04	0.51			
	U	W	Q	V	P	R	DC	DB	DA	DP
X	0.0001	0.0319	0.1390	-0.0151	-0.4766	-0.4060	0.1016	0.1234	-0.0007	-0.0002
Z	-0.1238	-0.4594	0.0822	-0.1376	-0.1466	0.2015	-1.3886	0.0359	0.0010	0.0008
R	0.0029	-0.0137	-0.2089	-0.0154	0.2182	-0.5023*	-0.0012	-0.0537	0.0003	0.0051
Y	0.0146	-0.0039	-0.4550	-0.0452	-0.1861	0.3125	-0.0380	0.0020	0.1051	0.2352
L'	0.0192	-0.0164	-0.8656	-0.0411	-0.4131	-0.1297*	-0.0384	0.0030	0.1905	0.1476
M'	-0.0067	-0.0216	-0.1061	0.0639	-0.3839	-0.6865	0.1509	-0.0012	0.0287	-0.4896

*This derivative was transcribed accurately from the original source but exceeds the usual range of values and should be used with due caution.

TABLE V-3 CONTINUED
UH-IH STABILITY AND CONTROL DERIVATIVES-- SI UNITS
(BODY-FIXED FRL AXIS SYSTEM)

CASE 158		60 KT		LEVEL FLIGHT AT SEA LEVEL			2948 KG		MID CG	
	PHI	THETA	PSI	ALPHA	BETA	GAMMA	ΘHR	B1S	A1S	ΘTR
	-0.72	3.97	0.00	3.97	-0.05	0.00	11.86	1.88	-1.42	1.82
	IDOT	ZDOT	U0	V0	W0	VT0				
	30.87	0.00	30.79	-0.03	2.14	30.87				
	U	W	Q	V	P	R	DC	DB	DA	DP
X	-0.0290	0.0945	0.5024	0.0041	-0.3983	-0.0873	0.1426	0.0886	-0.0007	-0.0078
Z	0.0382	-1.0862	-0.6576	-0.0271	-0.6393	0.5758	-1.7075	0.4166	0.0032	-0.0015
M	0.0093	-0.0125	-0.4831	0.0022	0.1892	0.0134	-0.0029	-0.0543	0.0002	-0.0049
Y	0.0021	-0.0092	-0.4397	-0.1503	-0.5813	0.5791	-0.0145	0.0077	0.1057	0.2889
L'	-0.0006	-0.0253	-0.8033	-0.0372	-0.9716	0.2618	-0.0121	0.0174	0.1920	0.1824
M'	-0.0062	-0.0433	-0.1668	0.1193	-0.1677	-1.3532	0.0695	0.0205	0.0299	-0.6011

CASE 159		100 KT		LEVEL FLIGHT AT SEA LEVEL			2948 KG		MID CG	
	PHI	THETA	PSI	ALPHA	BETA	GAMMA	ΘHR	B1S	A1S	ΘTR
	-1.14	2.81	0.00	2.81	-0.06	0.00	12.96	4.83	-1.86	2.26
	IDOT	ZDOT	U0	V0	W0	VT0				
	51.44	0.00	51.38	-0.05	2.53	51.44				
	U	W	Q	V	P	R	DC	DB	DA	DP
X	-0.0564	0.1363	0.5271	0.0090	-0.3135	-0.1051	0.2119	0.0374	-0.0023	-0.0198
Z	0.1276	-1.2349	-1.3186	-0.0374	-1.1189	0.6840	-1.9483	0.7504	-0.0051	-0.0072
M	0.0159	-0.0300	-0.6601	0.0005	0.1613	0.0158	-0.0248	-0.0507	0.0005	-0.0010
Y	0.0060	-0.0283	-0.4413	-0.2205	-0.5517	0.7705	-0.0456	0.0232	0.1084	0.3674
L'	0.0088	-0.0573	-0.8635	-0.0377	-0.9015	0.3514	-0.0640	0.0447	0.1964	0.2328
M'	0.0041	-0.0342	-0.4768	0.1442	-0.1560	-1.8071	0.0865	0.0224	0.0294	-0.7637

CASE 160		1 KT		LEVEL FLIGHT AT SEA LEVEL			2948 KG		FWD CG	
	PHI	THETA	PSI	ALPHA	BETA	GAMMA	ΘHR	B1S	A1S	ΘTR
	-1.06	-0.72	0.00	-0.72	0.01	0.00	13.59	-5.63	-1.45	5.41
	IDOT	ZDOT	U0	V0	W0	VT0				
	0.51	0.00	0.51	0.00	-0.01	0.51				
	U	W	Q	V	P	R	DC	DB	DA	DP
X	-0.0126	-0.0074	0.1490	-0.0255	-0.4875	-0.0131	-0.0261	0.1268	-0.0005	-0.0000
Z	-0.1936	-0.4665	0.1297	-0.1345	-0.0515	0.6651	-1.3973	0.0382	0.0013	0.0017
M	0.0032	-0.0140	-0.2174	-0.0158	0.2181	-0.0264	0.0018	-0.0538	0.0002	0.0052
Y	0.0130	-0.0039	-0.4531	-0.0447	-0.1881	0.3334	-0.0381	0.0026	0.1048	0.2354
L'	0.0158	-0.0164	-0.6708	-0.0398	-0.4127	0.1149	-0.0373	0.0035	0.1875	0.1424
M'	-0.0084	-0.0211	0.8651	0.0651	-0.3846	-0.7536	0.1548	-0.0025	0.0236	-0.5011

TABLE V-3 CONTINUED
UH-1H STABILITY AND CONTROL DERIVATIVES -- SI UNITS
(BODY-FIXED FRL AXIS SYSTEM)

CASE 161		60 KT		LEVEL FLIGHT AT SEA LEVEL		2948 KG		FWD CG		
	PHI	THETA	PSI	ALPHA	BETA	GAMMA	ΘMR	B1S	A1S	ΘTR
	-0.68	-0.52	0.00	-0.52	0.01	0.00	11.92	-2.56	-1.34	1.76
	IDOT	ZDOT	UO	VO	WO	VTO				
	30.87	0.00	30.87	0.00	-0.28	30.87				
	U	W	Q	V	P	R	DC	DB	DA	DP
X	-0.0261	0.0088	0.4527	0.0019	-0.4540	-0.0124	0.0009	0.1240	-0.0019	-0.0073
Z	-0.0353	-1.0930	-0.7281	-0.0250	-0.5424	0.6358	-1.7199	0.4142	-0.0019	-0.0048
H	0.0104	-0.0179	-0.5133	0.0020	0.1899	0.0115	-0.0045	-0.0527	0.0005	-0.0041
Y	0.0010	-0.0084	-0.4442	-0.1518	-0.5842	0.6020	-0.0134	0.0069	0.1060	0.2883
L*	-0.0029	-0.0236	-0.6347	-0.0266	-0.9626	0.2527	-0.0096	0.0158	0.1899	0.1763
N*	-0.0091	-0.0436	0.7137	0.1296	-0.1341	-1.4242	0.0708	0.0204	0.0234	-0.6138

CASE 162		35 KT		18 M/S		SEA LEVEL		2948 KG		FWD CG	
	PHI	THETA	PSI	ALPHA	BETA	GAMMA	ΘMR	B1S	A1S	ΘTR	
	-2.37	7.88	0.00	-82.11	2.35	90.00	18.06	2.93	-3.12	8.05	
	IDOT	ZDOT	UO	VO	WO	VTO					
	0.00	-18.11	2.48	0.74	-17.92	18.11					
	U	W	Q	V	P	R	DC	DB	DA	DP	
X	-0.0117	0.1094	-1.8998*	0.0027	-0.4413	-0.0634	0.2190	0.1395	-0.0035	-0.0230	
Z	0.0498	-0.7809	-2.7161	-0.1008	-0.3687	1.1391	-1.5357	0.0484	0.0168	0.0191	
H	0.0047	-0.0937	-2.8568	0.0008	0.1686	0.0756	-0.0974	-0.0571	0.0016	0.0494	
Y	0.0094	-0.0592	-0.6029	-0.0934	0.1739	0.6489	-0.0946	0.0036	0.1192	0.2572	
L*	0.0174	-0.0700	-2.4840	-0.0558	0.2902	0.2946	-0.1009	0.0065	0.2133	0.1613	
N*	-0.0033	0.1164	-0.3116	0.1396	-0.3554	-1.3170	0.3338	0.0016	0.0249	-0.5455	

CASE 163		60 KT		16 M/S		SEA LEVEL		2948 KG		FWD CG	
	PHI	THETA	PSI	ALPHA	BETA	GAMMA	ΘMR	B1S	A1S	ΘTR	
	-2.09	3.85	0.00	-28.36	0.99	32.22	17.50	2.51	-3.49	6.26	
	IDOT	ZDOT	UO	VO	WO	VTO					
	26.11	-16.46	27.16	0.54	-14.66	30.87					
	U	W	Q	V	P	R	DC	DB	DA	DP	
X	-0.0393	0.0901	-0.0720	0.0080	-0.3936	-0.1772	0.1456	0.1139	-0.0029	-0.0251	
Z	0.0788	-0.9749	-0.8708	-0.0690	-0.6809	1.1577	-1.7103	0.3487	0.0165	0.0042	
H	-0.0202	-0.1507	-0.3208	0.0087	0.1534	0.0497	-0.0674	-0.0486	0.0012	0.0145	
Y	0.0118	-0.0534	-0.5720	-0.1257	0.0217	0.7859	-0.0856	0.0169	0.1214	0.2793	
L*	0.0121	-0.0636	-0.9519	-0.0424	0.0553	0.3458	-0.0862	0.0248	0.2170	0.1757	
N*	-0.0311	0.0908	0.0180	0.1665	-0.3342	-1.6471	0.3240	-0.0232	0.0249	-0.5925	

* This derivative was transcribed accurately from the original source but exceeds the usual range of values and should be used with due caution.

TABLE V-3 CONTINUED
UH-1H STABILITY AND CONTROL DERIVATIVES -- SI UNITS
(BODY-FIXED FRL AXIS SYSTEM)

CASE 164*		31 KT		-16 M/S		SEA LEVEL		2948 KG		FWD CG	
PHI	THETA	PSI	ALPHA	BETA	GAMMA	ΘMR	B1S	A1S	ΘTR		
0.00	-2.44	0.00	87.56	0.00	-90.00	9.48	-7.68	-0.14	-0.03		
	XDOT	ZDOT	U0	V0	W0	VT0					
	0.00	15.85	0.67	0.00	15.84	15.85					
	U	W	Q	V	P	R	DC	DB	DA	DP	
X							-0.0432	0.0036	-0.0540	-0.0013	
Z							-0.7202	0.0356	0.0221	0.0000	
H							0.0140	-0.0010	0.0236	0.0006	
Y							0.0024	0.0672	0.0017	0.5511	
L*							0.0121	0.0602	0.0021	0.3264	
H*							0.0438	-0.2990	-0.0046	-1.1720	

CASE 165		60 KT		-9 M/S		SEA LEVEL		2948 KG		FWD CG	
PHI	THETA	PSI	ALPHA	BETA	GAMMA	ΘMR	B1S	A1S	ΘTR		
0.05	-1.43	0.00	16.09	0.01	-17.53	8.47	-4.80	-0.25	-0.08		
	XDOT	ZDOT	U0	V0	W0	VT0					
	29.43	9.30	29.66	0.01	8.56	30.87					
	U	W	Q	V	P	R	DC	DB	DA	DP	
X	-0.0218	-0.0056	0.8201	0.0011	-0.4590	-0.0101	-0.0517	0.1249	-0.0012	0.0004	
Z	-0.0790	-1.0168	-0.7363	-0.0051	-0.3781	0.3120	-1.6666	0.3748	-0.0009	0.0029	
H	0.0086	-0.0309	-0.6238	-0.0005	0.1951	0.0154	0.0151	-0.0517	0.0003	-0.0004	
Y	-0.0026	0.0139	-0.4135	-0.1439	-0.8959	0.5710	0.0217	0.0004	0.0958	0.3045	
L*	-0.0043	0.0045	-0.5345	-0.0411	-1.4796	0.2276	0.0250	0.0096	0.1721	0.1848	
H*	-0.0026	-0.1028	0.9852	0.1243	-0.0071	-1.4083	-0.0683	0.0460	0.0224	-0.6484	

CASE 166		1 KT		LEVEL FLIGHT AT SEA LEVEL		2948 KG		AFT CG		
PHI	THETA	PSI	ALPHA	BETA	GAMMA	ΘMR	B1S	A1S	ΘTR	
-1.08	9.14	0.00	9.14	-0.17	0.00	13.61	4.14	-1.55	5.48	
	XDOT	ZDOT	U0	V0	W0	VT0				
	0.51	0.00	0.51	-0.00	0.08	0.51				
	U	W	Q	V	P	R	DC	DB	DA	DP
X	0.0001	0.0690	0.1343	0.0040	-0.4525	-0.1827	0.2268	0.1215	-0.0013	-0.0016
Z	-0.0538	-0.4474	0.0417	-0.1253	-0.2290	0.6354	-1.3719	0.0376	0.0036	0.0082
H	0.0027	-0.0134	-0.2060	0.0014	0.2193	0.0376	-0.0041	-0.0541	0.0004	0.0053
Y	0.0162	-0.0037	-0.4582	-0.0474	-0.1921	0.3154	-0.0378	0.0019	0.1049	0.2357
L*	0.0227	-0.0162	-1.0583	-0.0327	-0.4229	0.1190	-0.0388	0.0027	0.1924	0.1533
H*	-0.0049	-0.0218	-1.0650	-0.0648	-0.1905	-0.6212	0.1492	-0.0011	0.0335	-0.4792

* Stability derivatives for Case Number 164 were omitted in the basic data source (C. P. 5), however, the remaining data were transcribed and presented here.

TABLE V-3 CONTINUED
UH-1H STABILITY AND CONTROL DERIVATIVES -- SI UNITS
(BODY-FIXED FRL AXIS SYSTEM)

CASE 167		60 KT		LEVEL FLIGHT AT SEA LEVEL			2948 KG	AFT CG		
	PHI	THETA	PSI	ALPHA	BETA	GAMMA	ØMR	B1S	A1S	ØTR
	-0.78	8.34	0.00	8.34	-0.11	0.00	11.82	6.31	-1.53	1.91
	XDOT	ZDOT		UØ	VØ	WØ	VTO			
	30.87	0.00		30.54	-0.06	4.48	30.87			
	U	W	Q	V	P	R	DC	DB	DA	DP
X	-0.0449	0.1784	0.5448	0.0066	-0.3322	-0.1332	0.2826	0.0530	-0.0011	-0.0076
Z	0.1110	-1.0694	-0.6089	-0.0293	-0.7346	0.5042	-1.6914	0.4172	0.0015	-0.0049
H	0.0078	-0.0084	-0.4602	0.0023	0.1908	0.0158	-0.0014	-0.0561	0.0003	-0.0062
Y	0.0037	-0.0104	-0.4364	-0.1492	-0.5829	0.5563	-0.0169	0.0081	0.1030	0.2893
L'	0.0025	-0.0278	-0.9743	-0.0473	-0.9903	0.2649	-0.0168	0.0182	0.1894	0.1884
M'	-0.0031	-0.0431	-1.0492	0.1092	-0.2093	-1.2896	0.0679	0.0200	0.0338	-0.5883

CASE 168		60 KT		17 M/S		SEA LEVEL		2948 KG	AFT CG		
	PHI	THETA	PSI	ALPHA	BETA	GAMMA	ØMR	B1S	A1S	ØTR	
	-2.08	9.29	0.00	-23.12	0.82	32.43	17.45	7.35	-3.66	6.31	
	XDOT	ZDOT		UØ	VØ	WØ	VTO				
	26.05	-16.55		28.39	0.44	-12.12	30.87				
	U	W	Q	V	P	R	DC	DB	DA	DP	
X	-0.0563	0.1707	-0.0165	0.0163	-0.3142	-0.2764	0.2984	0.0851	-0.0046	-0.0248	
Z	0.1538	-0.9765	-0.6849	-0.0727	-0.8188	1.0608	-1.6943	0.3522	0.0133	-0.0038	
H	-0.0227	-0.0807	-0.2457	0.0117	0.1797	0.0138	-0.0085	-0.0633	0.0009	0.0093	
Y	0.0156	-0.0526	-0.5439	-0.1488	-0.0009	0.7209	-0.0872	0.0183	0.1210	0.2792	
L'	0.0161	-0.0689	-1.1160	-0.0358	0.0152	0.3574	-0.0937	0.0282	0.2217	0.1865	
M'	-0.0378	0.0818	-0.9909	0.1387	-0.3386	-1.5197	0.3120	-0.0205	0.0354	-0.5664	

CASE 169		60 KT		-10 M/S		SEA LEVEL		2948 KG	AFT CG		
	PHI	THETA	PSI	ALPHA	BETA	GAMMA	ØMR	B1S	A1S	ØTR	
	0.02	5.14	0.00	24.04	0.01	-18.90	8.21	1.78	-0.30	-0.03	
	XDOT	ZDOT		UØ	VØ	WØ	VTO				
	29.20	10.00		28.19	0.01	12.57	30.87				
	U	W	Q	V	P	R	DC	DB	DA	DP	
X	-0.0208	0.1066	0.9060	0.0002	-0.4014	-0.0518	0.1496	0.0779	-0.0013	-0.0004	
Z	0.0117	-0.9662	-0.5315	-0.0050	-0.4888	0.2278	-1.6343	0.3668	-0.0013	0.0030	
H	0.0267	-0.0763	-0.6033	-0.0035	0.2062	0.0148	0.0511	-0.0614	0.0005	-0.0006	
Y	-0.0040	0.0137	-0.4145	-0.1152	-0.9050	0.5409	0.0225	-0.0009	0.0941	0.3060	
L'	-0.0049	0.0046	-0.7970	-0.0421	-1.5376	0.2370	0.0262	0.0069	0.1732	0.1985	
M'	0.0086	-0.1022	-0.3210	0.1226	-0.0949	-1.2943	-0.0721	0.0436	0.0313	-0.6225	

TABLE V-3 CONTINUED
UH-1H STABILITY AND CONTROL DERIVATIVES -- SI UNITS
(BODY-FIXED FRL AXIS SYSTEM)

CASE 170		1 KT		LEVEL FLIGHT AT SEA LEVEL			4309 KG	MID CG		
	PHI	THETA	PSI	ALPHA	BETA	GAMMA	QHR	B1S	A1S	QTR
	-1.09	4.88	0.00	4.88	-0.09	0.00	15.40	-0.08	-1.74	7.54
	XDOT	ZDOT	UO	VO	WO	VT0				
	0.51	0.00	0.51	-0.00	0.04	0.51				
	U	W	Q	V	P	R	DC	DB	DA	DP
X	-0.0056	0.0257	0.2206	-0.0088	-0.3844	-0.1050	0.0861	0.1264	-0.0008	-0.0003
Z	-0.0716	-0.3286	0.0916	-0.0819	-0.1184	0.6666	-1.0106	0.0344	0.0011	0.0015
M	0.0077	-0.0132	-0.3135	0.0066	0.2504	0.0371	-0.0021	-0.0801	0.0005	0.0069
Y	0.0159	-0.0039	-0.3725	-0.0439	-0.3208	0.2326	-0.0326	0.0014	0.1072	0.1709
L'	0.0322	-0.0161	-0.9162	-0.0526	-0.7415	0.1608	-0.0514	0.0033	0.2518	0.1844
M'	-0.0038	-0.0204	-0.1973	0.0689	-0.3041	-0.7102	0.1860	-0.0001	0.0367	-0.4585

CASE 171		60 KT		LEVEL FLIGHT AT SEA LEVEL			4309 KG	MID CG		
	PHI	THETA	PSI	ALPHA	BETA	GAMMA	QHR	B1S	A1S	QTR
	-0.62	4.72	0.00	4.72	-0.05	0.00	13.31	2.54	-1.64	2.49
	XDOT	ZDOT	UO	VO	WO	VT0				
	30.87	0.00	30.76	-0.03	2.54	30.87				
	U	W	Q	V	P	R	DC	DB	DA	DP
X	-0.0229	0.0590	0.4992	0.0011	-0.3190	-0.0885	0.0864	0.1038	-0.0017	-0.0067
Z	0.0059	-0.7220	-0.3868	-0.0217	-0.4567	0.5806	-1.1488	0.2841	0.0006	-0.0024
M	0.0120	-0.0048	-0.5572	0.0040	0.2217	0.0127	0.0116	-0.0832	0.0008	-0.0055
Y	0.0005	-0.0035	-0.3300	-0.1076	-0.5725	0.3813	-0.0061	0.0059	0.1059	0.1962
L'	-0.0041	-0.0157	-0.7637	-0.0675	-1.2689	0.3143	-0.0014	0.0166	0.2485	0.2119
M'	-0.0119	-0.0523	-0.0608	0.0998	-0.2160	-1.2097	0.0975	0.0247	0.0351	-0.5261

CASE 172		100 KT		LEVEL FLIGHT AT SEA LEVEL			4309 KG	MID CG		
	PHI	THETA	PSI	ALPHA	BETA	GAMMA	QHR	B1S	A1S	QTR
	-0.83	3.91	0.00	3.91	-0.06	0.00	13.97	5.08	-1.72	2.63
	XDOT	ZDOT	UO	VO	WO	VT0				
	51.44	0.00	51.32	-0.05	3.50	51.44				
	U	W	Q	V	P	R	DC	DB	DA	DP
X	-0.0402	0.0737	0.5559	0.0052	-0.2742	-0.0984	0.1055	0.0782	-0.0016	-0.0161
Z	0.0736	-0.8133	-0.9184	-0.0234	-0.7401	0.6366	-1.2900	0.5047	0.0032	-0.0026
M	0.0171	-0.0124	-0.7303	0.0014	0.2028	0.0183	0.0071	-0.0859	0.0008	0.0002
Y	0.0030	-0.0149	-0.3230	-0.1551	-0.5768	0.5086	-0.0227	0.0145	0.1088	0.2507
L'	0.0046	-0.0425	-0.7630	-0.0788	-1.2568	0.4291	-0.0414	0.0378	0.2548	0.2716
M'	0.0015	-0.0567	-0.1844	0.1195	-0.1644	-1.6042	0.0876	0.0384	0.0358	-0.6710

TABLE V-3 CONTINUED
UH-IH STABILITY AND CONTROL DERIVATIVES -- SI UNITS
(BODY-FIXED FRL AXIS SYSTEM)

CASE 173		1 KT		LEVEL FLIGHT AT SEA LEVEL			4309 KG		FWD CG	
	PHI	THETA	PSI	ALPHA	BETA	GAMMA	ΘMR	B1S	A1S	ΘTR
	-1.09	1.95	0.00	1.95	-0.04	0.00	15.38	-2.92	-1.70	7.50
	IDOT		ZDOT	U0	V0	W0	VTO			
	0.51		0.00	0.51	-0.00	0.02	0.51			
	U	W	Q	V	P	R	DC	DB	DA	DP
X	-0.0090	0.0092	0.2171	-0.0134	-0.3914	-0.0799	0.0322	0.1277	-0.0007	-0.0004
Z	-0.1014	-0.3320	0.1134	-0.0796	-0.0634	0.6789	-1.0134	0.0372	0.0035	0.0087
M	0.0078	-0.0136	-0.3168	0.0066	0.2500	0.0276	-0.0007	-0.0798	0.0005	0.0072
Y	0.0150	-0.0040	-0.3723	-0.0437	-0.3198	0.2374	-0.0327	0.0018	0.1072	0.1709
L*	0.0299	-0.0162	-0.8501	-0.0517	-0.7351	0.1636	-0.0511	0.0041	0.2500	0.1821
N*	-0.0052	-0.0202	0.3018	0.0704	-0.2963	-0.7273	0.1882	0.0003	0.0326	-0.4647

CASE 174		60 KT		LEVEL FLIGHT AT SEA LEVEL			4309 KG		FWD CG	
	PHI	THETA	PSI	ALPHA	BETA	GAMMA	ΘMR	B1S	A1S	ΘTR
	-0.60	1.99	0.00	1.99	-0.02	0.00	13.34	-0.12	-1.59	2.45
	IDOT		ZDOT	U0	V0	W0	VTO			
	30.87		0.00	30.85	-0.01	1.07	30.87			
	U	W	Q	V	P	R	DC	DB	DA	DP
X	-0.0218	0.0250	0.4828	0.0001	-0.3418	-0.0530	0.0298	0.1189	-0.0010	-0.0066
Z	-0.0231	-0.7238	-0.4178	-0.0205	-0.4036	0.6123	-1.1527	0.2842	0.0023	0.0017
M	0.0129	-0.0077	-0.5744	0.0039	0.2199	0.0083	0.0110	-0.0826	0.0005	-0.0052
Y	0.0001	-0.0033	-0.3303	-0.1082	-0.5706	0.3952	-0.0053	0.0066	0.1076	0.1960
L*	-0.0051	-0.0151	-0.6990	-0.0623	-1.2556	0.3233	0.0007	0.0185	0.2510	0.2090
N*	-0.0142	-0.0520	0.4127	0.1057	-0.1923	-1.2436	0.0994	0.0262	0.0321	-0.5333

CASE 175		8 KT		4 M/S		SEA LEVEL		4309 KG		FWD CG	
	PHI	THETA	PSI	ALPHA	BETA	GAMMA	ΘMR	B1S	A1S	ΘTR	
	-1.31	2.75	0.00	-87.25	1.31	90.00	16.18	-2.19	-1.98	8.32	
	IDOT		ZDOT	U0	V0	W0	VTO				
	0.00		-3.96	0.19	0.09	-3.96	3.96				
	U	W	Q	V	P	R	DC	DB	DA	DP	
X	-0.0199	0.0167	0.2367	-0.0158	-0.3835	-0.0653	0.0480	0.1285	-0.0009	-0.0035	
Z	-0.0378	-0.3689	-0.0728	-0.0821	-0.1174	0.7374	-1.0133	0.0363	0.0067	0.0183	
M	0.0115	-0.0254	-0.3554	0.0038	0.2425	0.0159	-0.0084	-0.0801	0.0007	0.0177	
Y	0.0131	-0.0197	-0.4768	-0.0487	-0.2751	0.2699	-0.0393	0.0017	0.1089	0.1761	
L*	0.0273	-0.0362	-0.9696	-0.0574	-0.6255	0.1974	-0.0627	0.0038	0.2540	0.1889	
N*	-0.0002	0.0226	0.4382	0.0783	-0.3038	-0.8048	0.2141	-0.0011	0.0330	-0.4780	

TABLE V-3 CONTINUED
UH-1H STABILITY AND CONTROL DERIVATIVES -- SI UNITS
(BODY-FIXED FRL AXIS SYSTEM)

CASE 176	60 KT		8 M/S		SEA LEVEL		4309 KG	FWD CG		
	PHI	THETA	PSI	ALPHA	BETA	GAMMA	ΘHR	BTS	A1S	ΘTR
	-1.26	0.29	0.00	-15.46	0.34	15.76	16.37	-0.87	-2.74	5.68
	IDOT	ZDOT	U0	V0	W0	VT0				
	29.71	-8.38	29.75	0.18	-8.23	30.87				
	U	W	Q	V	P	R	DC	DB	DA	DP
X	-0.0243	0.0236	0.3239	0.0014	-0.3499	-0.0538	0.0029	0.1324	-0.0012	-0.0153
Z	-0.0164	-0.6854	-0.4300	-0.0343	-0.4123	0.8180	-1.1437	0.2684	0.0057	-0.0019
H	0.0191	0.0299	-0.4027	0.0070	0.2175	-0.0120	0.0230	-0.0889	0.0005	0.0023
Y	0.0040	-0.0184	-0.3813	-0.1192	-0.3567	0.4625	-0.0323	0.0103	0.1142	0.1919
L'	-0.0065	-0.0463	-0.7795	-0.0519	-0.7762	0.3708	-0.0446	0.0235	0.2661	0.2066
M'	-0.0256	0.0151	0.6527	0.1152	-0.2965	-1.3815	0.2245	0.0009	0.0326	-0.5211

CASE 177	60 KT		-8 M/S		SEA LEVEL		4309 KG	FWD CG		
	PHI	THETA	PSI	ALPHA	BETA	GAMMA	ΘHR	BTS	A1S	ΘTR
	-0.01	1.53	0.00	16.06	-0.00	-14.53	10.56	-1.35	-0.63	0.06
	IDOT	ZDOT	U0	V0	W0	VT0				
	29.88	7.74	29.66	-0.00	8.54	30.87				
	U	W	Q	V	P	R	DC	DB	DA	DP
X	-0.0177	0.0239	0.6895	-0.0014	-0.3482	-0.0379	0.0122	0.1150	-0.0014	-0.0005
Z	-0.0434	-0.6765	-0.4604	-0.0083	-0.3030	0.4336	-1.1148	0.2537	0.0008	0.0003
H	0.0114	-0.0256	-0.6584	0.0012	0.2239	0.0213	0.0183	-0.0786	0.0006	-0.0011
Y	-0.0037	0.0098	-0.3111	-0.1035	-0.7336	0.3713	0.0150	0.0005	0.1002	0.2068
L'	-0.0088	0.0107	-0.6528	-0.0700	-1.6110	0.2875	0.0343	0.0063	0.2336	0.2201
M'	-0.0046	-0.0911	0.4785	0.1043	-0.0837	-1.2268	-0.0012	0.0409	0.0297	-0.5631

CASE 178	1 KT		LEVEL FLIGHT AT SEA LEVEL		4309 KG		AFT CG			
	PHI	THETA	PSI	ALPHA	BETA	GAMMA	ΘHR	BTS	A1S	ΘTR
	-1.10	7.82	0.00	7.82	-0.15	0.00	15.39	2.77	-1.78	7.55
	IDOT	ZDOT	U0	V0	W0	VT0				
	0.51	0.00	0.51	-0.00	0.07	0.51				
	U	W	Q	V	P	R	DC	DB	DA	DP
X	-0.0056	0.0416	0.2177	-0.0157	-0.3736	-0.1288	0.1398	0.1251	-0.0012	-0.0014
Z	-0.0418	-0.3237	0.0823	-0.0987	-0.1611	0.6665	-1.0037	0.0371	0.0034	0.0080
H	0.0050	-0.0154	-0.3143	-0.0163	0.2508	-0.0329	-0.0034	-0.0805	0.0006	0.0072
Y	0.0168	-0.0038	-0.3759	-0.0422	-0.3220	0.2282	-0.0323	0.0015	0.1073	0.1712
L'	0.0345	-0.0158	-0.9905	-0.0643	-0.7484	0.1600	-0.0512	0.0033	0.2536	0.1876
M'	-0.0024	-0.0205	-0.7027	0.0659	-0.3114	-0.6936	0.1847	-0.0005	0.0412	-0.4521

TABLE V-3 CONCLUDED
UH-1H STABILITY AND CONTROL DERIVATIVES -- SI UNITS
(BODY-FIXED FRL AXIS SYSTEM)

CASE 179		60 KT	LEVEL FLIGHT AT SEA LEVEL			4309 KG	AFT CG			
	PRI	THETA	PSI	ALPHA	BETA	GAMMA	ØMR	B1S	A1S	ØTR
	-0.64	7.41	0.00	7.41	-0.08	0.00	13.27	5.19	-1.69	2.53
		XDOT	ZDOT	U0	V0	W0	VTO			
		30.87	0.00	30.61	-0.04	3.98	30.87			
	U	W	Q	V	P	R	DC	DB	DA	DP
X	-0.0270	0.0927	0.5146	0.0023	-0.2907	-0.1191	0.1430	0.0895	-0.0019	-0.0067
Z	0.0349	-0.7176	-0.3544	-0.0227	-0.5005	0.5493	-1.1424	0.2857	0.0002	-0.0029
H	0.0109	-0.0025	-0.5432	0.0041	0.2222	0.0159	0.0119	-0.0843	0.0010	-0.0064
Y	0.0009	-0.0037	-0.3276	-0.1071	-0.5730	0.3705	-0.0064	0.0060	0.1047	0.1965
L'	-0.0028	-0.0163	-0.8229	-0.0723	-1.2789	0.3107	-0.0022	0.0170	0.2472	0.2148
M'	-0.0095	-0.0525	-0.5292	0.0941	-0.2385	-1.1749	0.0965	0.0247	0.0390	-0.5191

CASE 180		60 KT	10 M/S	SEA LEVEL			4309 KG	AFT CG			
	PRI	THETA	PSI	ALPHA	BETA	GAMMA	ØMR	B1S	A1S	ØTR	
	-1.42	8.25	0.00	-9.99	0.25	18.24	16.64	6.14	-3.01	6.14	
		XDOT	ZDOT	U0	V0	W0	VTO				
		29.32	-9.66	30.40	0.13	-5.35	30.87				
	U	W	Q	V	P	R	DC	DB	DA	DP	
X	-0.0317	0.0950	0.3408	0.0067	-0.2746	-0.1716	0.1482	0.1019	-0.0023	-0.0158	
Z	0.0572	-0.6957	-0.4547	-0.0382	-0.5398	0.7599	-1.1360	0.2743	0.0044	-0.0062	
H	0.0160	-0.0119	-0.4012	0.0066	0.2417	0.0075	-0.0101	-0.0823	0.0011	-0.0015	
Y	0.0075	-0.0193	-0.3766	-0.1164	-0.3469	0.4249	-0.0349	0.0110	0.1141	0.1919	
L'	0.0074	-0.0419	-0.8798	-0.0618	-0.7614	0.3657	-0.0594	0.0291	0.2694	0.2112	
M'	-0.0285	0.0168	-0.5802	0.1005	-0.3342	-1.2843	0.2315	-0.0002	0.0415	-0.5062	

CASE 181		60 KT	-8 M/S	SEA LEVEL			4309 KG	AFT CG			
	PRI	THETA	PSI	ALPHA	BETA	GAMMA	ØMR	B1S	A1S	ØTR	
	-0.03	6.32	0.00	21.14	-0.01	-14.82	10.48	3.39	-0.70	0.14	
		XDOT	ZDOT	U0	V0	W0	VTO				
		29.84	7.89	28.79	-0.01	11.13	30.87				
	U	W	Q	V	P	R	DC	DB	DA	DP	
X	-0.0186	0.0778	0.7246	-0.0010	-0.3120	-0.0791	0.1104	0.0933	-0.0009	-0.0019	
Z	-0.0008	-0.6523	-0.3714	-0.0086	-0.3671	0.3935	-1.0999	0.2564	0.0019	0.0048	
H	0.0225	-0.0645	-0.6444	-0.0011	0.2261	0.0216	0.0274	-0.0830	0.0003	-0.0015	
Y	-0.0039	0.0097	-0.3070	-0.0933	-0.7291	0.3591	0.0167	0.0020	0.1004	0.2064	
L'	-0.0086	0.0108	-0.7566	-0.0700	-1.6240	0.2929	0.0387	0.0098	0.2372	0.2251	
M'	0.0029	-0.0895	-0.3562	0.1010	-0.1387	-1.1577	0.0003	0.0400	0.0379	-0.5458	

TABLE V-4
UH-1H STABILITY AND CONTROL DERIVATIVES -- US UNITS
(BODY-FIXED FRL AXIS SYSTEM)

CASE 119 -40 KT LEVEL FLIGHT AT SEA LEVEL 8000 LB MID CG

	PHI	THETA	PSI	ALPHA	BETA	GAMMA	ΘMR	B1S	A1S	ΘTR
	-0.70	3.38	0.00	-176.62	0.04	180.00	12.71	-2.98	-0.36	2.54
	XDOT		ZDOT	U0	V0	W0	VT0			
	-67.51		0.00	-67.39	0.05	-3.98	67.51			
	U	W	Q	V	P	R	DC	DB	DA	DP
X	-0.0234	0.0452	1.5028	-0.0031	-1.3647	-0.1972	0.7091	1.1480	-0.0015	0.0424
Z	0.1767	-0.6921	0.4462	-0.0113	0.5916	1.9518	-10.4083	-1.5763	-0.0358	-0.0248
H	0.0004	0.0084	-0.0564	0.0001	0.2072	0.0455	-0.0356	-0.1739	0.0005	0.0328
Y	-0.0021	-0.0217	-1.2258	-0.0479	-1.6110	0.9911	-0.3067	-0.0321	0.8738	1.6932
L'	0.0019	-0.0156	-0.7668	-0.0171	-0.9371	0.2419	-0.1536	-0.0247	0.5573	0.4241
N'	0.0076	-0.0123	0.0669	0.0262	-0.0318	-0.8473	0.2385	-0.0299	0.0851	-1.2413

CASE 120 -20 KT LEVEL FLIGHT AT SEA LEVEL 8000 LB MID CG

	PHI	THETA	PSI	ALPHA	BETA	GAMMA	ΘMR	B1S	A1S	ΘTR
	-0.90	2.53	0.00	-177.47	0.04	180.00	13.58	-3.23	-0.72	4.41
	XDOT		ZDOT	U0	V0	W0	VT0			
	-33.76		0.00	-33.72	0.02	-1.49	33.76			
	U	W	Q	V	P	R	DC	DB	DA	DP
X	-0.0122	0.0142	0.9670	-0.0047	-1.3692	-0.2238	0.4575	1.0665	-0.0068	0.0480
Z	0.2715	-0.4965	-0.9894	-0.0277	0.1700	1.9232	-9.3180	-0.6308	-0.0162	0.0355
H	0.0059	0.0032	-0.1062	0.0007	0.2168	0.0457	-0.0092	-0.1679	0.0012	0.0287
Y	-0.0014	-0.0171	-1.2951	-0.0389	-1.2926	0.7004	-0.3020	-0.0267	0.8612	1.4157
L'	0.0042	-0.0120	-0.8008	-0.0144	-0.7529	0.1640	-0.1336	-0.0161	0.5511	0.3593
N'	0.0104	-0.0063	0.2140	0.0191	-0.0815	-0.6211	0.3418	-0.0072	0.0870	-1.0365

CASE 121 -10 KT LEVEL FLIGHT AT SEA LEVEL 8000 LB MID CG

	PHI	THETA	PSI	ALPHA	BETA	GAMMA	ΘMR	B1S	A1S	ΘTR
	-1.01	3.98	0.00	-176.02	0.07	180.00	14.17	-1.77	-1.11	5.65
	XDOT		ZDOT	U0	V0	W0	VT0			
	-16.88		0.00	-16.84	0.02	-1.17	16.88			
	U	W	Q	V	P	R	DC	DB	DA	DP
X	-0.0345	0.0221	0.8455	-0.0059	-1.3783	-0.3057	0.6588	1.0693	-0.0053	0.0514
Z	0.2192	-0.3993	-1.3143	-0.0453	-0.1426	2.1001	-9.4407	-0.2497	-0.0092	0.0298
H	0.0056	-0.0034	-0.2736	0.0011	0.2253	0.0465	0.0023	-0.1687	0.0010	0.0265
Y	0.0030	-0.0122	-1.1646	-0.0438	-1.0602	0.8664	-0.2961	-0.0102	0.8741	1.5981
L'	0.0070	-0.0097	-0.8720	-0.0178	-0.6428	0.1469	-0.1205	-0.0054	0.5587	0.4131
N'	0.0093	-0.0046	0.0244	0.0212	-0.1760	-0.7148	0.4025	-0.0013	0.0865	-1.1718

TABLE V-4 CONTINUED
UH-1H STABILITY AND CONTROL DERIVATIVES -- US UNITS
(BODY-FIXED FRL AXIS SYSTEM)

CASE 122 1 KT LEVEL FLIGHT AT SEA LEVEL 8000 LB MID CG

	PHI	THETA	PSI	ALPHA	BETA	GAMMA	ØMR	BIS	AIS	ØTR
	-1.07	4.04	0.00	4.04	-0.08	0.00	14.51	-0.90	-1.60	6.44
	XDOT	ZDOT	U0	V0	W0	VT0				
	1.69	0.00	1.68	-0.00	0.12	1.69				
	U	W	Q	V	P	R	DC	DB	DA	DP
X	-0.0034	0.0250	0.5797	-0.0077	-1.3861	-0.2549	0.6806	1.0406	-0.0071	-0.0062
Z	-0.0991	-0.3850	0.2913	-0.0982	-0.3965	2.2129	-9.7745	0.3214	0.0300	0.0702
M	0.0019	-0.0038	-0.1900	0.0014	0.2342	0.0385	-0.0033	-0.1691	0.0011	0.0158
Y	0.0150	-0.0040	-1.3355	-0.0451	-0.8760	0.8785	-0.2902	0.0141	0.8842	1.6328
L'	0.0077	-0.0049	-0.8779	-0.0127	-0.5720	0.1391	-0.1125	0.0084	0.5632	0.4231
N'	-0.0017	-0.0063	-0.0597	0.0209	-0.3176	-0.7094	0.4364	-0.0010	0.0827	-1.1963

CASE 123 10 KT LEVEL FLIGHT AT SEA LEVEL 8000 LB MID CG

	PHI	THETA	PSI	ALPHA	BETA	GAMMA	ØMR	BIS	AIS	ØTR
	-0.99	3.95	0.00	3.95	-0.07	0.00	14.15	-0.68	-1.78	5.74
	XDOT	ZDOT	U0	V0	W0	VT0				
	16.88	0.00	16.84	-0.02	1.16	16.88				
	U	W	Q	V	P	R	DC	DB	DA	DP
X	-0.0036	0.0300	0.8169	-0.0056	-1.3627	-0.2607	0.6176	1.0300	-0.0059	-0.0210
Z	-0.1841	-0.4456	1.1132	-0.0512	-0.5945	2.0436	-9.4592	0.4954	0.0085	-0.0284
M	0.0019	-0.0028	-0.2695	0.0020	0.2333	0.0250	0.0068	-0.1709	0.0008	0.0003
Y	0.0149	-0.0016	-1.3639	-0.0544	-1.0962	0.8944	-0.2252	0.0227	0.8849	1.6058
L'	0.0060	-0.0035	-0.8566	-0.0121	-0.6855	0.1429	-0.0784	0.0138	0.5629	0.4128
N'	-0.0056	-0.0062	0.0274	0.0211	-0.3037	-0.7329	0.3987	0.0028	0.0808	-1.1776

CASE 124 20 KT LEVEL FLIGHT AT SEA LEVEL 8000 LB MID CG

	PHI	THETA	PSI	ALPHA	BETA	GAMMA	ØMR	BIS	AIS	ØTR
	-0.86	3.70	0.00	3.70	-0.06	0.00	13.57	-0.47	-1.79	4.59
	XDOT	ZDOT	U0	V0	W0	VT0				
	33.76	0.00	33.69	-0.03	2.18	33.76				
	U	W	Q	V	P	R	DC	DB	DA	DP
X	-0.0046	0.0380	1.0693	-0.0045	-1.3189	-0.2394	0.5631	1.0171	-0.0006	-0.0137
Z	-0.1978	-0.5667	1.1713	-0.0178	-0.7951	1.8644	-9.2923	0.8788	0.0326	0.0291
M	0.0012	-0.0009	-0.2947	0.0021	0.2266	0.0148	0.0156	-0.1733	-0.0001	-0.0088
Y	0.0133	-0.0014	-1.3373	-0.0654	-1.3429	0.8773	-0.1414	0.0411	0.8891	1.4100
L'	0.0039	-0.0011	-0.8152	-0.0121	-0.8210	0.1442	-0.0327	0.0269	0.5657	0.3633
N'	-0.0087	-0.0071	0.1064	0.0216	-0.2786	-0.7396	0.1512	0.0150	0.0829	-1.0138

TABLE V-4 CONTINUED
 UH-1H STABILITY AND CONTROL DERIVATIVES -- US UNITS
 (BODY-FIXED FRL AXIS SYSTEM)

CASE 125		40 KT		LEVEL FLIGHT AT SEA LEVEL			8000 LB	MID CG		
	PHI	THETA	PSI	ALPHA	BETA	GAMMA	ΘMR	B1S	A1S	ΘTR
	-0.68	4.15	0.00	4.15	-0.05	0.00	12.76	0.73	-1.63	2.71
	XDOT	ZDOT	U0	V0	W0	VT0				
	67.51	0.00	67.34	-0.06	4.88	67.51				
	U	W	Q	V	P	R	DC	DB	DA	DP
X	-0.0144	0.0545	1.3920	-0.0003	-1.2467	-0.2662	0.7010	0.9278	-0.0127	-0.0277
Z	-0.0668	-0.7680	-0.3180	-0.0262	-1.1861	1.8070	-10.3359	1.7268	0.0002	-0.0532
M	0.0025	-0.0018	-0.4184	0.0014	0.2138	0.0088	0.0183	-0.1730	0.0017	-0.0200
Y	0.0070	-0.0023	-1.2940	-0.0942	-1.7136	1.2003	-0.0752	0.0307	0.8757	1.5972
L'	0.0017	-0.0037	-0.7981	-0.0144	-1.0403	0.2255	-0.0054	0.0233	0.5570	0.4131
N'	-0.0059	-0.0116	0.0279	0.0275	-0.2508	-1.0228	0.2608	0.0304	0.0781	-1.1721

CASE 126		60 KT		LEVEL FLIGHT AT SEA LEVEL			8000 LB	MID CG		
	PHI	THETA	PSI	ALPHA	BETA	GAMMA	ΘMR	B1S	A1S	ΘTR
	-0.65	3.91	0.00	3.91	-0.04	0.00	12.58	1.72	-1.50	2.10
	XDOT	ZDOT	U0	V0	W0	VT0				
	101.27	0.00	101.03	-0.08	6.90	101.27				
	U	W	Q	V	P	R	DC	DB	DA	DP
X	-0.0244	0.0665	1.6342	0.0022	-1.1632	-0.2721	0.8087	0.8362	-0.0148	-0.0557
Z	0.0123	-0.8757	-1.6172	-0.0235	-1.7359	1.9185	-11.5243	2.8179	-0.0099	-0.0383
M	0.0032	-0.0027	-0.5230	0.0009	0.2043	0.0131	0.0125	-0.1742	0.0018	-0.0136
Y	0.0010	-0.0056	-1.2425	-0.1248	-1.8915	1.5187	-0.0798	0.0504	0.8756	1.9485
L'	-0.0008	-0.0061	-0.7735	-0.0160	-1.1266	0.2915	-0.0162	0.0401	0.5574	0.5058
N'	-0.0028	-0.0149	-0.0281	0.0335	-0.1946	-1.2827	0.2098	0.0575	0.0790	-1.4287

CASE 127		80 KT		LEVEL FLIGHT AT SEA LEVEL			8000 LB	MID CG		
	PHI	THETA	PSI	ALPHA	BETA	GAMMA	ΘMR	B1S	A1S	ΘTR
	-0.73	3.56	0.00	3.56	-0.05	0.00	12.81	2.95	-1.49	2.07
	XDOT	ZDOT	U0	V0	W0	VT0				
	135.02	0.00	134.76	-0.11	8.39	135.02				
	U	W	Q	V	P	R	DC	DB	DA	DP
X	-0.0340	0.0788	1.7281	0.0041	-1.0932	-0.3010	0.9506	0.7074	-0.0207	-0.0800
Z	0.0571	-0.9464	-2.6911	-0.0242	-2.3697	2.0065	-12.4550	3.9264	-0.0423	-0.1085
M	0.0040	-0.0041	-0.6126	0.0005	0.1967	0.0192	-0.0002	-0.1714	0.0021	-0.0092
Y	0.0020	-0.0115	-1.2347	-0.1534	-1.9441	1.7792	-0.1491	0.0749	0.8787	2.2432
L'	0.0004	-0.0099	-0.7824	-0.0169	-1.1435	0.1434	-0.0630	0.0577	0.5589	0.5829
N'	-0.0008	-0.0161	-0.1171	0.0376	-0.1555	-1.4281	0.1895	0.0736	0.0775	-1.6446

TABLE V-4 CONTINUED
UH-1H STABILITY AND CONTROL DERIVATIVES -- US UNITS
(BODY-FIXED FRL AXIS SYSTEM)

CASE 128		100 KT		LEVEL FLIGHT AT SEA LEVEL			8000 LB	MID CG		
	PHI	THETA	PSI	ALPHA	BETA	GAMMA	ΘHR	βIS	αIS	θTR
	-0.94	3.02	0.00	3.02	-0.05	0.00	13.42	4.46	-1.74	2.41
	XDOT		ZDOT	U0	V0	W0	VT0			
	168.78		0.00	168.54	-0.15	8.91	168.78			
	U	W	Q	V	P	R	DC	DB	DA	DP
X	-0.0451	0.0925	1.7727	0.0063	-0.9858	-0.3160	1.1402	0.5568	-0.0185	-0.1423
Z	0.0888	-0.9963	-3.4493	-0.0285	-2.9758	2.1661	-13.1274	5.0738	-0.0283	-0.0532
M	0.0050	-0.0066	-0.7012	0.0003	0.1838	0.0173	-0.0223	-0.1728	0.0016	-0.0013
Y	0.0038	-0.0195	-1.2146	-0.1815	-1.8661	2.0207	-0.2541	0.1414	0.9021	2.4831
L'	0.0018	-0.0147	-0.7883	-0.0178	-1.0889	0.3945	-0.1256	0.0996	0.5734	0.6465
N'	0.0010	-0.0148	-0.2407	0.0404	-0.1554	-1.7052	0.2104	0.0818	0.0806	-1.8181

CASE 129		120 KT		LEVEL FLIGHT AT SEA LEVEL			9000 LB	MID CG		
	PHI	THETA	PSI	ALPHA	BETA	GAMMA	ΘHR	βIS	αIS	θTR
	-1.29	2.22	0.00	2.22	-0.05	0.00	14.46	6.23	-2.22	3.03
	XDOT		ZDOT	U0	V0	W0	VT0			
	202.54		0.00	202.38	-0.18	7.85	202.54			
	U	W	Q	V	P	R	DC	DB	DA	DP
X	-0.0565	0.1053	1.7155	0.0099	-0.8365	-0.3818	1.3425	0.3770	-0.0230	-0.2684
Z	0.1155	-1.0305	-4.0105	-0.0373	-3.6234	2.3678	-13.6269	6.1710	-0.0213	-0.0305
M	0.0061	-0.0093	-0.7778	-0.0001	0.1588	0.0199	-0.0483	-0.1735	0.0019	0.0296
Y	0.0068	-0.0307	-1.2199	-0.2096	-1.7337	2.2503	-0.4331	0.2356	0.9193	2.7183
L'	0.0036	-0.0211	-0.8030	-0.0186	-1.0047	0.4489	-0.2242	0.1598	0.5872	0.7116
N'	0.0014	-0.0108	-0.3493	0.0425	-0.1782	-1.8854	0.2813	0.0765	0.0882	-1.9859

CASE 130		130 KT		LEVEL FLIGHT AT SEA LEVEL			8000 LB	MID CG		
	PHI	THETA	PSI	ALPHA	BETA	GAMMA	ΘHR	βIS	αIS	θTR
	-1.51	1.69	0.00	1.69	-0.04	0.00	15.15	7.21	-2.55	3.46
	XDOT		ZDOT	U0	V0	W0	VT0			
	219.41		0.00	219.32	-0.17	6.48	219.41			
	U	W	Q	V	P	R	DC	DB	DA	DP
X	-0.0622	0.1099	1.6544	0.0114	-0.7758	-0.4217	1.4228	0.2944	-0.0230	-0.3418
Z	0.1266	-1.0373	-4.3091	-0.0422	-3.8888	2.5117	-13.8352	6.6677	-0.0118	-0.0213
M	0.0066	-0.0104	-0.8115	-0.0002	0.1498	0.0228	-0.0603	-0.1774	0.0016	0.0406
Y	0.0078	-0.0366	-1.2382	-0.2234	-1.6293	2.3563	-0.5193	0.2924	0.9384	2.7911
L'	0.0040	-0.0243	-0.8205	-0.0188	-0.9195	0.4743	-0.2015	0.1922	0.5995	0.7122
N'	0.0009	-0.0075	-0.4014	0.0433	-0.1487	-1.9741	0.3177	0.0501	0.0910	-2.0366

TABLE V-4 CONTINUED
UH-IH STABILITY AND CONTROL DERIVATIVES -- US UNITS
(BODY-FIXED FRL AXIS SYSTEM)

CASE 131		22 KT	2178 FT/MIN	SEA LEVEL	9000 LB	MID CG				
	PHI	THETA	PSI	ALPHA	BETA	GAMMA	ΘRR	B1S	A1S	ΘTR
	-1.78	7.26	0.00	-82.73	1.76	90.00	16.97	2.28	-2.57	8.37
	XDOT	ZDOT	U0	V0	W0	VT0				
	0.00	-36.30	4.59	1.12	-35.99	36.30				
	U	W	Q	V	P	R	DC	DB	DA	DP
X	-0.0140	0.0645	-2.6805*	-0.0013	-1.2844	-0.5307	1.3277	1.0855	-0.0144	-0.0825
Z	0.0059	-0.5336	-4.2985	-0.0941	-0.8328	2.7813	-10.1030	0.3147	0.0580	0.0973
M	0.0034	-0.0142	-1.7509	0.0005	0.2086	0.2280	-0.0909	-0.1755	0.0018	0.0816
Y	0.0110	-0.0355	-1.7753	-0.0659	-0.3511	1.3273	-0.4981	0.0141	0.9354	1.7518
L*	0.0061	-0.0163	-0.3754	-0.0180	-0.2191	0.2495	-0.2060	0.0081	0.5958	0.4622
N*	-0.0004	0.0188	-0.3835	0.0317	-0.3248	-0.9932	0.6598	-0.0042	0.0861	-1.2819

CASE 132		60 KT	2436 FT/MIN	SEA LEVEL	8000 LB	MID CG				
	PHI	THETA	PSI	ALPHA	BETA	GAMMA	ΘRR	B1S	A1S	ΘTR
	-1.62	3.10	0.00	-20.52	0.57	23.64	16.94	1.81	-3.15	6.14
	XDOT	ZDOT	U0	V0	W0	VT0				
	92.77	-40.60	94.84	1.01	-35.50	101.27				
	U	W	Q	V	P	R	DC	DB	DA	DP
X	-0.0321	0.0585	0.5294	0.0052	-1.1806	-0.4037	0.7048	0.9949	-0.0146	-0.1657
Z	0.0295	-0.8181	-1.7202	-0.0499	-1.7978	3.0943	-11.4865	2.5586	0.0747	-0.0064
M	-0.0034	-0.0138	-0.3519	0.0032	0.1993	-0.0016	0.0229	-0.1921	0.0011	0.0165
Y	0.0069	-0.0311	-1.4813	-0.1315	-0.6733	1.8906	-0.4442	0.1091	0.9796	1.8908
L*	0.0011	-0.0158	-0.8635	-0.0125	-0.3903	0.3661	-0.1681	0.0631	0.6232	0.4992
N*	-0.0086	0.0147	0.1512	0.0391	-0.3290	-1.4697	0.6756	-0.0269	0.0861	-1.3829

CASE 133		100 KT	1908 FT/MIN	SEA LEVEL	8000 LB	MID CG				
	PHI	THETA	PSI	ALPHA	BETA	GAMMA	ΘRR	B1S	A1S	ΘTR
	-1.66	4.42	0.00	-6.44	0.19	10.86	16.79	5.94	-2.98	4.87
	XDOT	ZDOT	U0	V0	W0	VT0				
	165.76	-31.80	167.71	0.55	-18.93	168.78				
	U	W	Q	V	P	R	DC	DB	DA	DP
X	-0.0516	0.0853	0.8876	0.0117	-0.9451	-0.5345	1.2556	0.6586	-0.0229	-0.2810
Z	0.1091	-0.9613	-3.9969	-0.0481	-3.1210	3.0716	-12.7212	4.8112	0.0408	-0.0092
M	0.0062	-0.0087	-0.6133	0.0002	0.1728	0.0419	-0.0373	-0.1929	0.0015	0.0418
Y	0.0088	-0.0375	-1.1983	-0.1897	-1.0721	2.2128	-0.5443	0.2378	1.0194	2.3683
L*	0.0035	-0.0227	-0.8958	-0.0145	-0.6265	0.4635	-0.2444	0.1411	0.6473	0.6255
N*	-0.0043	0.0073	-0.2884	0.0414	-0.2376	-1.8043	0.6034	-0.0373	0.0889	-1.7290

*This derivative was transcribed accurately from the original source but exceeds the usual range of values and should be used with due caution.

TABLE V-4 CONTINUED
UH-IH STABILITY AND CONTROL DERIVATIVES -- US UNITS
(BODY-FIXED FRL AXIS SYSTEM)

CASE 134		60 KT		-1596 FT/MIN		SEA LEVEL		8000 LB		MID CG	
	PHI	THETA	PSI	ALPHA	BETA	GAMMA	QHR	B1S	A1S	QTR	
	-0.01	3.14	0.00	18.37	-0.00	-15.23	9.64	0.09	-0.51	0.07	
	XDOT		ZDOT	UO	VO	WO	VTO				
	97.71		26.60	96.11	-0.01	31.92	101.27				
	U	W	Q	V	P	R	DC	DB	DA	DP	
X	-0.0179	0.0569	2.5029	0.0001	-1.1904	-0.1643	0.5487	0.8458	-0.0061	-0.0121	
Z	-0.0201	-0.8066	-1.6442	-0.0076	-1.2514	1.1946	-11.1286	2.5818	0.0106	0.0525	
M	0.0045	-0.0149	-0.6268	-0.0003	0.2055	0.0197	0.0445	-0.1698	0.0006	-0.0024	
Y	-0.0033	0.0107	-1.1538	-0.1165	-2.5818	1.4502	0.1500	0.0136	0.9262	2.0480	
L*	-0.0019	0.0022	-0.6970	-0.0181	-1.5345	0.2651	0.0830	0.0255	0.5265	0.5291	
N*	0.0004	-0.0285	0.1372	0.0335	-0.0801	-1.2678	-0.0662	0.1085	0.0775	-1.5026	

CASE 135		100 KT		-2946 FT/MIN		SEA LEVEL		8000 LB		MID CG	
	PHI	THETA	PSI	ALPHA	BETA	GAMMA	QHR	B1S	A1S	QTR	
	0.22	1.34	0.00	18.26	0.07	-16.91	7.47	-0.08	0.10	-0.32	
	XDOT		ZDOT	UO	VO	WO	VTO				
	161.48		49.10	160.28	0.20	52.87	168.78				
	U	W	Q	V	P	R	DC	DB	DA	DP	
X	-0.0295	0.0613	3.1881	0.0008	-1.1428	-0.0379	0.4328	0.6761	-0.0155	0.0075	
Z	0.0163	-0.8916	-3.8455	0.0019	-1.9298	0.7801	-12.4839	4.4569	-0.0104	-0.0135	
M	0.0069	-0.0215	-0.8871	-0.0008	0.2041	0.0052	0.0788	-0.1714	0.0014	-0.0077	
Y	-0.0029	0.0146	-1.0911	-0.1660	-3.0338	1.8706	0.2046	-0.0428	0.7497	2.6560	
L*	-0.0004	0.0024	-0.6553	-0.0204	-1.7880	0.3306	0.0661	0.0099	0.4764	0.6849	
N*	0.0059	-0.0423	0.1548	0.0398	0.0076	-1.6545	-0.3856	0.2395	0.0671	-1.9481	

CASE 136		6 KT		-600 FT/MIN		SEA LEVEL		8000 LB		MID CG	
	PHI	THETA	PSI	ALPHA	BETA	GAMMA	QHR	B1S	A1S	QTR	
	-0.90	3.56	0.00	93.56	-0.90	-90.00	13.99	-1.45	-1.33	5.56	
	XDOT		ZDOT	UO	VO	WO	VTO				
	0.00		10.00	-0.62	-0.16	9.98	10.00				
	U	W	Q	V	P	R	DC	DB	DA	DP	
X	-0.0098	0.0189	0.9135	-0.0135	-1.4009	-0.2768	0.5942	1.0329	-0.0051	0.0133	
Z	-0.0840	-0.3317	-0.0160	-0.1021	-0.1261	2.0856	-9.7761	0.2726	0.0116	0.0170	
M	0.0036	-0.0042	-0.2929	0.0012	0.2355	0.0369	0.0059	-0.1677	0.0008	0.0001	
Y	0.0176	0.0036	-1.1469	-0.0434	-1.0917	0.8500	-0.2408	0.0145	0.8772	1.5998	
L*	0.0088	-0.0019	-0.8021	-0.0124	-0.6748	0.1132	-0.0895	0.0073	0.5577	0.4123	
N*	-0.0016	-0.0114	-0.1117	0.0210	-0.2295	-0.7042	0.1917	-0.0039	0.0801	-1.1717	

TABLE V-4 CONTINUED
UH-IH STABILITY AND CONTROL DERIVATIVES -- US UNITS
(BODY-FIXED FRL AXIS SYSTEM)

CASE 137										
12 KT -1200 FT/MIN SEA LEVEL 8000 LB MID CG										
	PHI	THETA	PSI	ALPHA	BETA	GAMMA	ΘHR	B1S	A1S	ΘTR
	-0.75	3.07	0.00	93.07	-0.74	-90.00	13.52	-1.93	-1.13	4.58
	XDOT	ZDOT	U0	V0	W0	VT0				
	0.00	20.00	-1.07	-0.26	19.97	20.00				
	U	W	Q	V	P	R	DC	DB	DA	DP
X	-0.0065	0.0140	0.9729	-0.0138	-1.4171	-0.2398	0.5048	1.0253	-0.0038	0.0261
Z	-0.1137	-0.2920	0.1829	-0.1012	-0.2275	1.9955	-9.7262	0.2674	-0.0048	-0.0369
M	0.0038	-0.0040	-0.3080	0.0018	0.2361	0.0406	0.0158	-0.1667	0.0007	-0.0129
Y	0.0173	0.0076	-1.0582	-0.0425	-1.2173	0.7467	-0.1981	0.0174	0.8710	1.5982
L'	0.0092	-0.0000	-0.7647	-0.0119	-0.7306	0.1103	-0.0694	0.0079	0.5527	0.4102
N'	-0.0000	-0.0129	-0.0904	0.0217	-0.1688	-0.6275	0.3548	-0.0061	0.0772	-1.1733

CASE 138										
6 KT 600 FT/MIN SEA LEVEL 8000 LB MID CG										
	PHI	THETA	PSI	ALPHA	BETA	GAMMA	ΘHR	B1S	A1S	ΘTR
	-1.25	4.68	0.00	-85.31	1.25	90.00	15.13	-0.32	-1.82	7.04
	XDOT	ZDOT	U0	V0	W0	VT0				
	0.00	-10.00	0.82	0.22	-9.96	10.00				
	U	W	Q	V	P	R	DC	DB	DA	DP
X	-0.0132	0.0326	0.6321	-0.0118	-1.3612	-0.3182	0.8081	1.0513	-0.0077	-0.0228
Z	-0.0377	-0.4181	-0.2891	-0.1002	-0.5266	2.3279	-9.8095	0.2697	0.0215	0.0511
M	0.0028	-0.0066	-0.2849	0.0007	0.2329	0.0360	-0.0189	-0.1705	0.0011	0.0355
Y	0.0124	-0.0204	-1.7154	-0.0505	-0.7661	0.9622	-0.3394	0.0136	0.8957	1.6566
L'	0.0071	-0.0099	-0.9826	-0.0142	-0.4886	0.1602	-0.1349	0.0078	0.5705	0.4312
N'	0.0002	0.0059	0.0976	0.0238	-0.3023	-0.7611	0.4881	-0.0026	0.0835	-1.2140

CASE 139										
12 KT 1200 FT/MIN SEA LEVEL 8000 LB MID CG										
	PHI	THETA	PSI	ALPHA	BETA	GAMMA	ΘHR	B1S	A1S	ΘTR
	-1.44	5.50	0.00	-84.50	1.43	90.00	15.78	0.50	-2.09	7.53
	XDOT	ZDOT	U0	V0	W0	VT0				
	0.00	-20.00	1.92	0.50	-19.90	20.00				
	U	W	Q	V	P	R	DC	DB	DA	DP
X	-0.0157	0.0427	0.4617	-0.0105	-1.3362	-0.3859	0.9701	1.0632	-0.0084	-0.0440
Z	-0.0203	-0.4615	-0.3522	-0.0989	-0.6240	2.4894	-9.9136	0.2831	0.0348	0.0745
M	0.0029	-0.0095	-0.2992	0.0004	0.2221	0.0388	-0.0398	-0.1723	0.0011	0.0526
Y	0.0120	-0.0263	-1.7642	-0.0557	-0.6335	1.0844	-0.3953	0.0114	0.9097	1.6935
L'	0.0066	-0.0124	-1.0169	-0.0156	-0.3952	0.1907	-0.1602	0.0065	0.5796	0.4430
N'	-0.0002	0.0107	-0.0015	0.0264	-0.2947	-0.8100	0.5469	-0.0032	0.0853	-1.2404

TABLE V-4 CONTINUED
UH-IH STABILITY AND CONTROL DERIVATIVES -- US UNITS
(BODY-FIXED FRL AXIS SYSTEM)

CASE 140	60 KT		1200 FT/MIN		SEA LEVEL		8000 LB		MID CG	
	PHI	THETA	PSI	ALPHA	BETA	GAMMA	ΘMR	B1S	A1S	ΘTR
	-0.85	4.60	-1.13	-6.78	1.21	11.39	14.72	2.57	-2.30	4.12
	XDOT		ZDOT	U0	V0	W0	VT0			
	99.27		-20.00	100.54	2.14	-11.95	101.27			
	U	W	Q	V	P	R	DC	DB	DA	DP
X	-0.0255	0.0754	1.2017	0.0065	-1.1446	-0.3686	0.8912	0.8834	-0.0194	-0.0935
Z	0.0291	-0.8658	-1.8576	-0.0376	-1.9840	2.4571	-11.5340	2.7460	0.0510	-0.0801
M	0.0035	-0.0057	-0.4903	0.0012	0.1990	0.0051	0.0053	-0.1828	0.0016	-0.0159
Y	0.0039	-0.0172	-1.3222	-0.1310	-1.3386	1.6515	-0.2692	0.0842	0.9309	1.9203
L'	0.0005	-0.0119	-0.8304	-0.0133	-0.7994	0.3247	-0.0967	0.0539	0.5926	0.4997
M'	-0.0059	-0.0016	-0.0836	0.0348	-0.2767	-1.3486	0.4301	0.0145	0.0832	-1.4081

CASE 141	60 KT		600 FT/MIN		SEA LEVEL		8000 LB		MID CG	
	PHI	THETA	PSI	ALPHA	BETA	GAMMA	ΘMR	B1S	A1S	ΘTR
	-0.89	4.20	0.00	-1.47	0.02	5.67	13.65	2.09	-1.90	2.98
	XDOT		ZDOT	U0	V0	W0	VT0			
	100.77		-10.00	101.23	0.04	-2.59	101.27			
	U	W	Q	V	P	R	DC	DB	DA	DP
X	-0.0262	0.0656	1.2788	0.0030	-1.1655	-0.3201	0.8580	0.8515	-0.0155	-0.0768
Z	0.0199	-0.8727	-1.7199	-0.0296	-1.8025	2.1966	-11.5388	2.7992	-0.0034	-0.0560
M	0.0035	-0.0033	-0.4883	0.0011	0.2046	0.0105	0.0088	-0.1779	0.0017	-0.0129
Y	0.0029	-0.0114	-1.2825	-0.1273	-1.6099	1.5733	-0.1627	0.0652	0.9022	1.9295
L'	-0.0003	-0.0086	-0.7929	-0.0145	-0.9569	0.3074	-0.0500	0.0458	0.5743	0.5019
M'	-0.0043	-0.0081	-0.0311	0.0340	-0.2212	-1.3072	0.3214	0.0351	0.0809	-1.4146

CASE 142	60 KT		-600 FT/MIN		SEA LEVEL		8000 LB		MID CG	
	PHI	THETA	PSI	ALPHA	BETA	GAMMA	ΘMR	B1S	A1S	ΘTR
	-0.32	3.70	-0.40	9.37	0.35	-5.67	11.48	1.31	-1.09	1.34
	XDOT		ZDOT	U0	V0	W0	VT0			
	100.77		10.00	99.92	0.61	16.48	101.27			
	U	W	Q	V	P	R	DC	DB	DA	DP
X	-0.0225	0.0679	1.9609	0.0022	-1.1848	-0.2303	0.7492	0.8211	-0.0167	-0.0273
Z	0.0046	-0.8613	-1.6536	-0.0178	-1.5433	1.6319	-11.4367	2.7547	0.0000	-0.0425
M	0.0029	-0.0027	-0.5577	0.0007	0.2066	0.0167	0.0179	-0.1790	0.0020	-0.0133
Y	-0.0015	0.0021	-1.2169	-0.1228	-2.1655	1.4736	0.0105	0.0224	0.8478	1.9767
L'	-0.0014	-0.0023	-0.7569	-0.0173	-1.2897	0.2756	0.0232	0.0259	0.5400	0.5122
M'	-0.0014	-0.0028	-0.0033	0.0332	-0.1481	-1.2674	0.1030	0.0765	0.0775	-1.4500

TABLE V-4 CONTINUED
UH-1H STABILITY AND CONTROL DERIVATIVES -- US UNITS
(BODY-FIXED FRL AXIS SYSTEM)

CASE 143		60 KT		-1200 FT/MIN		SEA LEVEL		8000 LB		MID CG	
	PHI	THETA	PSI	ALPHA	BETA	GAMMA	ΘHR	BIS	AIS	ΘTR	
	-0.17	3.53	0.00	14.92	-0.04	-11.39	10.37	0.79	-0.74	0.53	
	IDOT	ZDOT	UO	VO	WO	VT0					
	99.27	20.00	97.85	-0.08	26.08	101.27					
	U	W	Q	V	P	R	DC	DB	DA	DP	
X	-0.0203	0.0672	2.2923	0.0007	-1.1963	-0.1974	0.6727	0.8204	-0.0114	-0.0176	
Z	-0.0057	-0.8364	-1.7162	-0.0118	-1.3878	1.3699	-11.2593	2.6491	-0.0027	0.0092	
M	0.0026	-0.0061	-0.5973	0.0005	0.2078	0.0197	0.0263	-0.1674	0.0014	-0.0072	
Y	-0.0026	0.0077	-1.1918	-0.1213	-2.4156	1.4529	0.0953	0.0121	0.8309	2.0109	
L*	-0.0018	0.0007	-0.7367	-0.0182	-1.4369	0.2693	0.0594	0.0225	0.5293	0.5203	
N*	-0.0001	-0.0256	0.0371	0.0332	-0.1088	-1.2603	-0.0002	0.0952	0.0768	-1.4751	

CASE 144		0 KT		LEVEL FLIGHT		10000 FT		8000 LB		MID CG	
	PHI	THETA	PSI	ALPHA	BETA	GAMMA	ΘHR	BIS	AIS	ΘTR	
	-1.22	4.12	0.00	4.12	-0.09	0.00	16.10	-0.89	-1.74	8.54	
	IDOT	ZDOT	UO	VO	WO	VT0					
	0.00	0.00	0.00	0.00	0.00	0.00					
	U	W	Q	V	P	R	DC	DB	DA	DP	
X	-0.0154	0.0178	1.2194	-0.0016	-1.3045	-0.2615	0.5361	1.0683	-0.0054	-0.0015	
Z	-0.0395	-0.2859	0.1279	-0.0711	-0.2171	2.2475	-7.5066	0.2488	0.0080	0.0191	
M	0.0028	-0.0050	-0.3361	-0.0009	0.2125	0.0365	-0.0049	-0.1731	0.0009	0.0176	
Y	0.0159	-0.0046	-1.2025	-0.0280	-1.2566	0.6884	-0.2500	0.0102	0.9039	1.3056	
L*	0.0095	-0.0044	-0.7510	-0.0041	-0.8090	0.0838	-0.0871	0.0063	0.5763	0.3387	
N*	0.0006	-0.0044	0.0016	0.0189	-0.3646	-0.6399	0.4378	-0.0002	0.0864	-0.9575	

CASE 145		60 KT		LEVEL FLIGHT		10000 FT		8000 LB		MID CG	
	PHI	THETA	PSI	ALPHA	BETA	GAMMA	ΘHR	BIS	AIS	ΘTR	
	-0.71	3.98	0.00	3.98	-0.05	0.00	13.95	2.00	-1.78	3.09	
	IDOT	ZDOT	UO	VO	WO	VT0					
	101.27	0.00	101.02	-0.09	7.02	101.27					
	U	W	Q	V	P	R	DC	DB	DA	DP	
X	-0.0230	0.0382	2.1173	-0.0002	-1.2219	-0.2449	0.4447	0.9371	-0.0135	-0.0582	
Z	-0.0085	-0.6122	-1.8525	-0.0195	-1.1264	1.9421	-8.2004	2.0299	0.0097	-0.0340	
M	0.0034	-0.0009	-0.5282	0.0013	0.2036	0.0055	0.0317	-0.1799	0.0016	-0.0139	
Y	0.0001	-0.0024	-1.1611	-0.0978	-2.2679	1.0660	-0.0462	0.0463	0.8880	1.4199	
L*	-0.0016	-0.0036	-0.7009	-0.0151	-1.4081	0.1639	0.0126	0.0364	0.5655	0.3732	
N*	-0.0032	-0.0120	0.1157	0.0242	-0.1543	-1.0220	0.2598	0.0500	0.0809	-1.0555	

TABLE V-4 CONTINUED
UH-1H STABILITY AND CONTROL DERIVATIVES -- US UNITS
(BODY-FIXED FRL AXIS SYSTEM)

CASE 146		100 KT		LEVEL FLIGHT		10000 FT		8000 LB		MID CG	
	PHI	THETA	PSI	ALPHA	BETA	GAMMA	ΘHR	B1S	A1S	ΘTR	
	-0.97	3.28	0.00	3.28	-0.06	0.00	14.61	4.72	-1.87	3.33	
	XDOT	ZDOT	U0	V0	W0	VT0					
	168.78	0.00	168.50	-0.16	9.65	168.78					
	U	W	Q	V	P	R	DC	DB	DA	DP	
X	-0.0373	0.0463	2.4377	0.0041	-1.1041	-0.2995	0.4979	0.8021	-0.0187	-0.1741	
Z	0.0548	-0.6733	-3.9878	-0.0201	-1.7900	2.0931	-8.8993	3.5076	-0.0024	-0.0184	
M	0.0045	-0.0023	-0.6820	0.0006	0.1843	0.0177	0.0289	-0.1886	0.0018	0.0230	
Y	0.0030	-0.0129	-1.1392	-0.1398	-2.2130	1.4509	-0.1853	0.1132	0.9064	1.8556	
L*	0.0010	-0.0102	-0.7113	-0.0170	-1.3529	0.2452	-0.0780	0.0810	0.5759	0.4861	
N*	0.0000	-0.0120	-0.0502	0.0290	-0.2899	-1.3524	0.2421	0.0755	0.0806	-1.3558	

CASE 147		20 KT		1992 FT/MIN		10000 FT		8000 LB		MID CG	
	PHI	THETA	PSI	ALPHA	BETA	GAMMA	ΘHR	B1S	A1S	ΘTR	
	-1.86	6.62	0.00	-83.38	1.84	90.00	18.29	1.66	-2.65	11.04	
	XDOT	ZDOT	U0	V0	W0	VT0					
	0.00	-33.20	3.83	1.07	-32.96	33.20					
	U	W	Q	V	P	R	DC	DB	DA	DP	
X	-0.0206	0.0427	0.5459	-0.0101	-1.3248	-0.4619	0.8920	1.0811	-0.0214	-0.0917	
Z	-0.0014	-0.3783	-0.0776	-0.0731	-0.6695	2.6833	-7.4000	0.3483	0.1018	0.2652	
M	0.0035	-0.0115	-0.3335	0.0006	0.2106	0.0517	-0.0536	-0.1761	0.0034	0.0782	
Y	0.0130	-0.0249	-1.6990	-0.0563	-0.7204	1.0071	-0.3828	0.0244	0.9435	1.3678	
L*	0.0072	-0.0118	-1.0257	-0.0176	-0.4795	0.1701	-0.1430	0.0150	0.6009	0.3641	
N*	0.0000	0.0119	-0.2456	0.0232	-0.4186	-0.8528	0.6054	-0.0022	0.0861	-0.9981	

CASE 148		60 KT		2142 FT/MIN		10000 FT		8000 LB		MID CG	
	PHI	THETA	PSI	ALPHA	BETA	GAMMA	ΘHR	B1S	A1S	ΘTR	
	-1.65	2.72	0.00	-17.92	0.51	20.64	17.83	1.63	-3.29	8.15	
	XDOT	ZDOT	U0	V0	W0	VT0					
	94.77	-35.70	96.35	0.90	-31.15	101.27					
	U	W	Q	V	P	R	DC	DB	DA	DP	
X	-0.0301	0.0324	1.0499	0.0027	-1.1942	-0.3161	0.3387	1.0496	-0.0163	-0.1533	
Z	0.0020	-0.5788	-2.3888	-0.0362	-1.2816	2.5981	-7.9739	1.8556	0.0539	-0.0475	
M	0.0005	-0.0035	-0.3680	0.0025	0.1874	-0.0148	0.0393	-0.1921	0.0017	0.0068	
Y	0.0049	-0.0195	-1.4048	-0.1068	-0.9780	1.3404	-0.2980	0.0827	0.9635	1.3402	
L*	-0.0000	-0.0102	-0.8189	-0.0124	-0.6304	0.2275	-0.0850	0.0486	0.6132	0.3508	
N*	-0.0070	0.0105	0.1870	0.0263	-0.4730	-1.1710	0.6263	-0.0171	0.0843	-0.9795	

TABLE V-4 CONTINUED
UH-1H STABILITY AND CONTROL DERIVATIVES -- US UNITS
(BODY-FIXED FRL AXIS SYSTEM)

CASE 149		60 KT	-1602 FT/MIN	10000 FT	9000 LB	MID CG				
	PHI	THETA	PSI	ALPHA	BETA	GAMMA	ΘHR	B1S	A1S	ΘTR
	-0.03	3.38	0.00	18.66	-0.01	-15.29	11.08	0.63	-0.80	0.16
	XDOT	ZDOT	U0	V0	W0	VT0				
	97.68	26.70	95.94	-0.02	32.41	101.27				
	U	W	Q	V	P	R	DC	DB	DA	DP
X	-0.0168	0.0340	2.8666	-0.0020	-1.1877	-0.1604	0.3107	0.9336	-0.0067	-0.0098
Z	-0.0350	-0.5680	-1.8635	-0.0088	-0.8763	1.4792	-8.0069	1.8336	0.0295	0.0553
H	0.0043	-0.0106	-0.6159	0.0001	0.2021	0.0167	0.0465	-0.1746	0.0007	-0.0016
Y	-0.0040	0.0088	-1.1071	-0.0901	-2.8691	1.0177	0.1365	0.0201	0.8601	1.5180
L*	-0.0025	0.0021	-0.6555	-0.0161	-1.7581	0.1512	0.0927	0.0260	0.5484	0.3924
M*	-0.0004	-0.0214	0.2162	0.0247	-0.2322	-0.9859	0.0490	0.0853	0.0818	-1.1139

CASE 150		100 KT	-2820 FT/MIN	10000 FT	8000 LB	MID CG				
	PHI	THETA	PSI	ALPHA	BETA	GAMMA	ΘHR	B1S	A1S	ΘTR
	0.23	2.05	0.00	18.22	0.07	-16.17	9.04	1.12	-0.09	-0.54
	XDOT	ZDOT	U0	V0	W0	VT0				
	162.10	47.00	160.32	0.21	52.76	168.78				
	U	W	Q	V	P	R	DC	DB	DA	DP
X	-0.0263	0.0378	3.5152	-0.0002	-1.1592	-0.0923	0.1986	0.7920	-0.0229	0.0217
Z	0.0097	-0.6167	-3.6774	-0.0008	-1.3002	1.2109	-8.9778	3.1677	-0.0070	-0.0645
H	0.0057	-0.0150	-0.8305	-0.0005	0.2014	0.0104	0.0742	-0.1752	0.0024	-0.0078
Y	-0.0028	0.0100	-1.0986	-0.1273	-3.2797	1.3088	0.1302	-0.0336	0.7875	1.9696
L*	-0.0006	0.0014	-0.6489	-0.0179	-1.9824	0.1856	0.0491	0.0058	0.5000	0.5090
M*	0.0047	-0.0306	0.2285	0.0291	-0.1069	-1.2729	-0.1976	0.1778	0.0687	-1.4452

CASE 151		1 KT	LEVEL FLIGHT AT SEA LEVEL			8000 LB	FWD CG			
	PHI	THETA	PSI	ALPHA	BETA	GAMMA	ΘHR	B1S	A1S	ΘTR
	-1.06	-0.72	0.00	-0.72	0.01	0.00	14.49	-5.55	-1.55	6.40
	XDOT	ZDOT	U0	V0	W0	VT0				
	1.69	0.00	1.69	0.00	-0.02	1.69				
	U	W	Q	V	P	R	DC	DB	DA	DP
X	-0.0131	-0.0061	0.6346	-0.0155	-1.4136	-0.1180	-0.1727	1.0696	-0.0041	-0.0005
Z	-0.1556	-0.3906	0.3755	-0.0951	-0.1568	2.1991	-9.8513	0.3022	0.0065	0.0014
H	0.0020	-0.0040	-0.2647	0.0014	0.2137	0.0248	0.0027	-0.1698	0.0007	0.0151
Y	0.0137	-0.0040	-1.3289	-0.0449	-0.8841	0.9012	-0.2924	0.0166	0.8816	1.6299
L*	0.0067	-0.0049	-0.7328	-0.0123	-0.5732	0.1182	-0.1110	0.0095	0.5552	0.4101
M*	-0.0022	-0.0062	0.8065	0.0214	-0.1131	-0.7369	0.4471	-0.0027	0.0680	-1.2225

TABLE V-4 CONTINUED
 UH-1H STABILITY AND CONTROL DERIVATIVES -- US UNITS
 (BODY-FIXED FRL AXIS SYSTEM)

CASE 152	60 KT			LEVEL FLIGHT AT SEA LEVEL			8000 LB	FWD CG		
	PHI	THETA	PSI	ALPHA	BETA	GAMMA	ΘMP	B1S	A1S	ΘTR
	-0.61	-0.47	0.00	-0.47	0.01	0.00	12.63	-2.57	-1.42	2.05
	XDOT		ZDOT	U0	V0	W0	VTO			
	101.27		0.00	101.26	0.01	-0.83	101.27			
	U	W	Q	V	P	R	DC	DB	DA	DP
X	-0.0242	-0.0001	1.5153	0.0004	-1.3044	-0.0904	-0.1134	1.0701	-0.0142	-0.0567
Z	-0.0445	-0.8792	-1.8167	-0.0217	-1.4619	2.0835	-11.5967	2.7991	-0.0053	-0.0397
M	0.0036	-0.0042	-0.5528	0.0009	0.2045	0.0099	0.0097	-0.1710	0.0015	-0.0105
Y	0.0003	-0.0053	-1.2536	-0.1260	-1.9014	1.5836	-0.0764	0.0477	0.8879	1.9446
L*	-0.0014	-0.0058	-0.6470	-0.0132	-1.1195	0.2891	-0.0133	0.0383	0.5588	0.4927
N*	-0.0038	-0.0149	0.7753	0.0364	-0.1646	-1.3472	0.2124	0.0579	0.0645	-1.4584

CASE 153	100 KT			LEVEL FLIGHT AT SEA LEVEL			8000 LB	FWD CG		
	PHI	THETA	PSI	ALPHA	BETA	GAMMA	ΘMR	B1S	A1S	ΘTR
	-0.89	-0.77	0.00	-0.77	0.01	0.00	13.57	0.78	-1.64	2.40
	XDOT		ZDOT	U0	V0	W0	VTO			
	168.78		0.00	168.76	0.04	-2.27	168.78			
	U	W	Q	V	P	R	DC	DB	DA	DP
X	-0.0383	0.0267	1.6065	0.0043	-1.2134	-0.1494	0.2196	0.9431	-0.0191	-0.1428
Z	0.0375	-1.0009	-3.7163	-0.0267	-2.6930	2.4357	-13.1403	5.0505	-0.0169	-0.0447
M	0.0058	-0.0101	-0.7558	0.0002	0.1808	0.0212	-0.0470	-0.1589	0.0013	0.0037
Y	0.0022	-0.0187	-1.2313	-0.1833	-1.8990	2.1063	-0.2398	0.1334	0.9359	2.4774
L*	0.0007	-0.0142	-0.6833	-0.0139	-1.0959	0.3915	-0.1138	0.0946	0.5884	0.6297
N*	0.0001	-0.0151	0.4489	0.0446	-0.1252	-1.7941	0.2201	0.0831	0.0674	-1.8552

CASE 154	1 KT			LEVEL FLIGHT AT SEA LEVEL			8000 LB	AFT CG		
	PHI	THETA	PSI	ALPHA	BETA	GAMMA	ΘMR	B1S	A1S	ΘTR
	-1.08	8.79	0.00	8.78	-0.17	0.00	14.51	3.74	-1.66	6.49
	XDOT		ZDOT	U0	V0	W0	VTO			
	1.69		0.00	1.67	-0.00	0.26	1.69			
	U	W	Q	V	P	R	DC	DB	DA	DP
X	-0.0032	0.0551	0.5925	-0.0491	-1.3146	-0.5062	1.5303	1.0314	-0.0082	-0.0059
Z	-0.0431	-0.3761	0.1580	0.0224	-0.6865	2.1284	-9.7073	0.2967	0.0138	0.0227
M	0.0011	-0.0044	-0.2574	0.0537	0.2346	0.0430	-0.0099	-0.1711	0.0011	0.0154
Y	0.0165	-0.0038	-1.3458	-0.0638	-0.8901	0.8525	-0.2876	0.0126	0.8846	1.6373
L*	0.0088	-0.0048	-1.0233	0.0175*	-0.5858	0.1140	-0.1111	0.0070	0.5694	0.4354
N*	-0.0011	-0.0053	-0.9258	0.0367	-0.1269	-0.6940	0.4318	-0.0023	0.0970	-1.1735

*This derivative was transcribed accurately from the original source but exceeds the usual range of values and should be used with due caution.

TABLE V-4 CONTINUED
UH-1H STABILITY AND CONTROL DERIVATIVES -- US UNITS
(BODY-FIXED FRL AXIS SYSTEM)

CASE 155		60 KT		LEVEL FLIGHT AT SEA LEVEL			8000 LB	AFT CG		
	PHI	THETA	PSI	ALPHA	BETA	GAMMA	ΘMR	B1S	A1S	ΘTR
	-0.69	8.20	0.00	8.20	-0.10	0.00	12.52	6.00	-1.59	2.17
	XDOT	ZDOT	U0	V0	W0	VTD				
	101.27	0.00	100.23	-0.17	14.44	101.27				
	U	W	Q	V	P	R	DC	DB	DA	DP
X	-0.0343	0.1321	1.7362	0.0043	-0.9871	-0.4255	1.7233	0.6064	-0.0146	-0.0555
Z	0.0692	-0.8647	-1.4576	-0.0253	-1.9942	1.7325	-11.4166	2.8382	-0.0150	-0.0397
H	0.0027	-0.0015	-0.5006	0.0009	0.2054	0.0164	0.0145	-0.1787	0.0021	-0.0168
Y	0.0021	-0.0061	-1.2283	-0.1238	-1.8918	1.4585	-0.0865	0.0550	0.9599	1.9521
L*	-0.0001	-0.0065	-0.8978	-0.0186	-1.1412	0.2920	-0.0213	0.0433	0.5538	0.5189
N*	-0.0017	-0.0149	-0.8290	0.0306	-0.2299	-1.2229	0.2072	0.0573	0.0935	-1.3987

CASE 156		100 KT		LEVEL FLIGHT AT SEA LEVEL			8000 LB	AFT CG		
	PHI	THETA	PSI	ALPHA	BETA	GAMMA	ΘMR	B1S	A1S	ΘTR
	-1.02	6.69	0.00	6.69	-0.12	0.00	13.33	8.17	-1.88	2.48
	XDOT	ZDOT	U0	V0	W0	VTD				
	168.78	0.00	167.63	-0.35	19.66	168.78				
	U	W	Q	V	P	R	DC	DB	DA	DP
X	-0.0601	0.1580	1.9010	0.0089	-0.7112	-0.4449	2.0743	0.1626	-0.0149	-0.1490
Z	0.1402	-0.9843	-3.1916	-0.0308	-3.1810	1.8899	-13.0462	5.0968	-0.0372	-0.0482
H	0.0041	-0.0038	-0.6556	0.0004	0.1858	0.0146	-0.0008	-0.1866	0.0017	-0.0053
Y	0.0061	-0.0210	-1.2031	-0.1800	-1.8195	1.9404	-0.2781	0.1565	0.8681	2.4891
L*	0.0032	-0.0156	-0.8974	-0.0214	-1.0747	0.3934	-0.1434	0.1091	0.5575	0.6636
N*	0.0016	-0.0141	-0.9365	0.0362	-0.1938	-1.6241	0.2029	0.0804	0.0924	-1.7807

CASE 157		1 KT		LEVEL FLIGHT AT SEA LEVEL			6500 LB	MID CG		
	PHI	THETA	PSI	ALPHA	BETA	GAMMA	ΘMR	B1S	A1S	ΘTR
	-1.07	4.24	0.00	4.24	-0.08	0.00	13.62	-0.72	-1.50	5.45
	XDOT	ZDOT	U0	V0	W0	VTD				
	1.69	0.00	1.68	-0.00	0.12	1.69				
	U	W	Q	V	P	R	DC	DB	DA	DP
X	0.0001	0.0319	0.4560	-0.0151	-1.5635	-1.3320	0.8463	1.0295	-0.0055	-0.0017
Z	-0.1238	-0.4594	0.2695	-0.1376	-0.4811	0.6613	-11.5713	0.2995	0.0086	0.0070
H	0.0009	-0.0042	-0.2089	-0.0047	0.2182	-0.5021*	-0.0030	-0.1363	0.0007	0.0131
Y	0.0146	-0.0039	-1.4929	-0.0452	-0.6171	1.0254	-0.3168	0.0171	0.9758	1.9600
L*	0.0058	-0.0050	-0.8656	-0.0125	-0.4131	-0.1297*	-0.0976	0.0076	0.4838	0.3749
N*	-0.0020	-0.0066	-0.1063	0.0195	-0.3839	-0.6965	0.3934	-0.0031	0.0729	-1.2435

*This derivative was transcribed accurately from the original source but exceeds the usual range of values and should be used with due caution.

TABLE V-4 CONTINUED
UH-1H STABILITY AND CONTROL DERIVATIVES -- US UNITS
(BODY-FIXED FRL AXIS SYSTEM)

CASE 158		60 KT		LEVEL FLIGHT AT SEA LEVEL			6500 LB	MID CG		
	PHI	THETA	PSI	ALPHA	BETA	GAMMA	ΘMR	B1S	A1S	ΘTR
	-0.72	3.97	0.00	3.97	-0.05	0.00	11.86	1.88	-1.42	1.82
	XDOT	ZDOT	U0	V0	W0	VTO				
	101.27	0.00	101.03	-0.09	7.01	101.27				
	U	W	Q	V	P	R	DC	DB	DA	DP
X	-0.0290	0.0945	1.6483	0.0041	-1.3068	-0.2866	1.1884	0.7380	-0.0057	-0.0651
Z	0.0382	-1.0862	-2.1574	-0.0271	-2.0975	1.8891	-14.2288	3.4718	0.0268	-0.0122
N	0.0028	-0.0038	-0.4831	0.0007	0.1892	0.0134	-0.0073	-0.1380	0.0006	-0.0123
Y	0.0021	-0.0092	-1.4426	-0.1503	-1.9073	1.9070	-0.1210	0.0642	0.8805	2.4072
L*	-0.0002	-0.0077	-0.8033	-0.0113	-0.9716	0.2618	-0.0307	0.0443	0.4877	0.4633
N*	-0.0019	-0.0132	-0.1668	0.0364	-0.1677	-1.3532	0.1764	0.0521	0.0759	-1.5267

CASE 159		100 KT		LEVEL FLIGHT AT SEA LEVEL			6500 LB	MID CG		
	PHI	THETA	PSI	ALPHA	BETA	GAMMA	ΘMR	B1S	A1S	ΘTR
	-1.14	2.81	0.00	2.81	-0.06	0.00	12.96	4.83	-1.86	2.26
	XDOT	ZDOT	U0	V0	W0	VTO				
	168.78	0.00	168.58	-0.16	8.29	168.78				
	U	W	Q	V	P	R	DC	DB	DA	DP
X	-0.0564	0.1363	1.7292	0.0090	-1.0284	-0.3449	1.7660	0.3117	-0.0192	-0.1654
Z	0.1276	-1.2349	-4.3261	-0.0374	-3.6710	2.2441	-16.2355	6.2531	-0.0422	-0.0602
N	0.0049	-0.0091	-0.6601	0.0002	0.1613	0.0158	-0.0629	-0.1288	0.0012	-0.0026
Y	0.0060	-0.0283	-1.4477	-0.2205	-1.8100	2.5279	-0.3802	0.1930	0.9033	3.0621
L*	0.0027	-0.0175	-0.8635	-0.0115	-0.9015	0.3514	-0.1626	0.1135	0.4989	0.5913
N*	0.0013	-0.0104	-0.4768	0.0440	-0.1560	-1.8071	0.2196	0.0569	0.0747	-1.9397

CASE 160		1 KT		LEVEL FLIGHT AT SEA LEVEL			6500 LB	FWD CG		
	PHI	THETA	PSI	ALPHA	BETA	GAMMA	ΘMR	B1S	A1S	ΘTR
	-1.06	-0.72	0.00	-0.72	0.01	0.00	13.59	-5.63	-1.45	5.41
	XDOT	ZDOT	U0	V0	W0	VTO				
	1.69	0.00	1.69	0.00	-0.02	1.69				
	U	W	Q	V	P	R	DC	DB	DA	DP
X	-0.0126	-0.0074	0.4889	-0.0255	-1.5994	-0.0410	-0.2177	1.0568	-0.0018	-0.0002
Z	-0.1936	-0.4665	0.4254	-0.1345	-0.1670	2.1822	-11.6440	0.3181	0.0107	0.0140
N	0.0010	-0.0043	-0.2174	-0.0048	0.2181	-0.0264	0.0046	-0.1366	0.0006	0.0132
Y	0.0130	-0.0039	-1.4865	-0.0447	-0.6172	1.0918	-0.1172	0.0214	0.8733	1.9615
L*	0.0048	-0.0050	-0.6708	-0.0121	-0.4127	0.1149	-0.0948	0.0089	0.4762	0.3618
N*	-0.0026	-0.0065	0.4653	0.0199	-0.3846	-0.7536	0.1931	-0.0065	0.0600	-1.2728

TABLE V-4 CONTINUED
UH-1H STABILITY AND CONTROL DERIVATIVES -- US UNITS
(BODY-FIXED FRL AXIS SYSTEM)

CASE 161		60 KT		LEVEL FLIGHT AT SEA LEVEL		6500 LB		FWD CG		
	PHI	THETA	PSI	ALPHA	BETA	GAMMA	QMR	B1S	A1S	QTR
	-0.68	-0.52	0.00	-0.52	0.01	0.00	11.92	-2.56	-1.34	1.76
	XDOT	ZDOT	U0	V0	W0	VT0				
	101.27	0.00	101.26	0.01	-0.92	101.27				
	U	W	Q	V	P	R	DC	DB	DA	DP
X	-0.0261	0.0098	1.4851	0.0019	-1.4895	-0.1064	0.0077	1.0312	-0.0160	-0.0608
Z	-0.0353	-1.0930	-2.3887	-0.0250	-1.7796	2.0859	-14.3328	3.4518	-0.0155	-0.0401
M	0.0032	-0.0055	-0.5133	0.0006	0.1899	0.0115	-0.0114	-0.1339	0.0013	-0.0103
Y	0.0010	-0.0084	-1.4573	-0.1518	-1.9168	1.9751	-0.1113	0.0572	0.9831	2.4029
L*	-0.0309	-0.0072	-0.6347	-0.0081	-0.9626	0.2527	-0.0243	0.0402	0.4823	0.4478
N*	-0.0028	-0.0133	0.7137	0.0395	-0.1341	-1.4242	0.1798	0.0518	0.0595	-1.5591

CASE 162		35 KT		3564 FT/MIN		SEA LEVEL		6500 LB		FWD CG	
	PHI	THETA	PSI	ALPHA	BETA	GAMMA	QMR	B1S	A1S	QTR	
	-2.37	7.88	0.00	-82.11	2.35	90.00	18.06	2.93	-3.12	8.05	
	XDOT	ZDOT	U0	V0	W0	VT0					
	0.00	-59.40	8.14	2.44	-58.79	59.40					
	U	W	Q	V	P	R	DC	DB	DA	DP	
X	-0.0117	0.1094	-6.2329*	0.0027	-1.4479	-0.2081	1.8254	1.1622	-0.0292	-0.1916	
Z	0.0498	-0.7809	-8.9112	-0.1008	-1.2096	3.7371	-12.7978	0.4030	0.1404	0.1588	
M	0.0014	-0.0285	-2.8568	0.0002	0.1686	0.0756	-0.2475	-0.1451	0.0041	0.1254	
Y	0.0094	-0.0592	-1.9781	-0.0934	0.5706	2.1289	-0.7886	0.0298	0.9930	2.1433	
L*	0.0053	-0.0213	-2.4840	-0.0170	0.2902	0.2946	-0.2564	0.0166	0.5417	0.4097	
N*	-0.0010	0.0355	-0.3116	0.0425	-0.3554	-1.3170	0.8477	0.0041	0.0632	-1.3855	

CASE 163		60 KT		3240 FT/MIN		SEA LEVEL		6500 LB		FWD CG	
	PHI	THETA	PSI	ALPHA	BETA	GAMMA	QMR	B1S	A1S	QTR	
	-2.09	3.85	0.00	-28.36	0.99	32.22	17.50	2.51	-3.49	6.26	
	XDOT	ZDOT	U0	V0	W0	VT0					
	95.67	-54.00	89.10	1.76	-48.09	101.27					
	U	W	Q	V	P	R	DC	DB	DA	DP	
X	-0.0333	0.0901	-0.2362	0.0080	-1.2912	-0.5815	1.2131	0.9491	-0.0242	-0.2091	
Z	0.0788	-0.9749	-2.9570	-0.0690	-2.2340	3.7982	-14.2521	2.9060	0.1374	0.0349	
M	-0.0062	-0.0459	-0.3208	0.0027	0.1534	0.0497	-0.1712	-0.1234	0.0031	0.0369	
Y	0.0118	-0.0534	-1.8767	-0.1257	0.0713	2.5783	-0.7110	0.1410	1.0113	2.3273	
L*	0.0037	-0.0194	-0.9519	-0.0129	0.9553	0.3459	-0.2188	0.0630	0.5513	0.4463	
N*	-0.0095	0.0277	0.0180	0.0508	-0.1342	-1.6371	0.8229	-0.0588	0.0612	-1.5050	

*This derivative was transcribed accurately from the original source but exceeds the usual range of values and should be used with due caution.

TABLE V-4 CONTINUED
UH-1H STABILITY AND CONTROL DERIVATIVES -- US UNITS
(BODY-FIXED FRL AXIS SYSTEM)

CASE 164*		31 KT	-3120 FT/MIN	SEA LEVEL	6500 LB	FWD CG					
PHI	THETA	PSI	ALPHA	BETA	GAMMA	ΘHR	B1S	A1S	ΘTR		
0.00	-2.44	0.00	87.56	0.00	-90.00	9.48	-7.68	-0.14	-0.03		
	XDOT	ZDOT	U0	V0	W0	VT0					
	0.00	52.00	2.21	0.00	51.95	52.00					
U	W	Q	V	P	R	DC	DB	DA	DP		
X						-0.3600	0.0298	-0.4503	-0.0105		
Z						-6.0017	0.2970	0.1838	0.0000		
M						0.0354	-0.0024	0.0601	0.0014		
Y						0.0204	0.5596	0.0140	4.5921		
L'						0.0306	0.1530	0.0052	0.8292		
N'						0.1113	-0.7594	-0.0117	-2.9768		

CASE 165		60 KT	-1830 FT/MIN	SEA LEVEL	6500 LB	FWD CG					
PHI	THETA	PSI	ALPHA	BETA	GAMMA	ΘHR	B1S	A1S	ΘTR		
0.05	-1.43	0.00	16.09	0.01	-17.53	8.47	-4.80	-0.25	-0.08		
	XDOT	ZDOT	U0	V0	W0	VT0					
	96.57	30.50	97.30	0.02	28.07	101.27					
U	W	Q	V	P	R	DC	DB	DA	DP		
X	-0.0218	-0.0056	2.6907	0.0011	-1.5058	-0.0331	-0.4310	1.0406	-0.0101	0.0031	
Z	-0.0790	-1.0168	-2.4158	-0.0051	-1.2406	1.0236	-13.8883	3.1238	-0.0074	0.0244	
M	0.0026	-0.0094	-0.6238	-0.0001	0.1951	0.0154	0.0383	-0.1312	0.0009	-0.0010	
Y	-0.0026	0.0139	-1.3567	-0.1439	-2.9394	1.8732	0.1811	0.0031	0.7987	2.5372	
L'	-0.0013	0.0014	-0.5345	-0.0125	-1.4796	0.2276	0.0635	0.0244	0.4371	0.4693	
N'	-0.0008	-0.0313	0.9852	0.0379	-0.0071	-1.4083	-0.1734	0.1170	0.0568	-1.6469	

CASE 166		1 KT	LEVEL FLIGHT AT SEA LEVEL	6500 LB	AFT CG						
PHI	THETA	PSI	ALPHA	BETA	GAMMA	ΘHR	B1S	A1S	ΘTR		
-1.08	9.14	0.00	9.14	-0.17	0.00	13.61	4.14	-1.55	5.48		
	XDOT	ZDOT	U0	V0	W0	VT0					
	1.69	0.00	1.67	-0.01	0.27	1.69					
U	W	Q	V	P	R	DC	DB	DA	DP		
X	0.0001	0.0690	0.4405	0.0040	-1.4847	-0.5994	1.8897	1.0128	-0.0105	-0.0136	
Z	-0.0538	-0.4474	0.1369	-0.1253	-0.7514	2.0847	-11.4495	0.3131	0.0300	0.0681	
M	0.0008	-0.0041	-0.2060	0.0004	0.2193	0.0376	-0.0105	-0.1375	0.0010	0.0136	
Y	0.0162	-0.0037	-1.5032	-0.0474	-0.5302	1.0348	-0.3147	0.0159	0.8742	1.9640	
L'	0.0069	-0.0050	-1.0581	-0.0100	-0.4229	0.1190	-0.0986	0.0070	0.4887	0.3895	
N'	-0.0015	-0.0066	-1.0650	0.0198	-0.1905	-0.6912	0.3790	-0.0028	0.0852	-1.2171	

*Stability derivatives for Case Number 164 were omitted in the basic data source (Ref. 5), however, the remaining data were transcribed and presented here.

TABLE V-4 CONTINUED
 UH-1H STABILITY AND CONTROL DERIVATIVES -- US UNITS
 (BODY-FIXED FRL AXIS SYSTEM)

CASE 167		60 KT	LEVEL FLIGHT AT SEA LEVEL			6500 LB	AFT CG			
	PHI	THETA	PSI	ALPHA	BETA	GAMMA	ΘMR	B1S	A1S	ΘTR
	-0.78	8.34	0.00	8.34	-0.11	0.00	11.82	6.31	-1.53	1.91
	XDOT		ZDOT	U0	V0	W0	VT0			
	101.27		0.00	100.20	-0.20	14.69	101.27			
	U	W	Q	V	P	R	DC	DB	DA	DP
X	-0.0449	0.1784	1.7874	0.0066	-1.0900	-0.4371	2.3549	0.4417	-0.0090	-0.0630
Z	0.1110	-1.0694	-1.9977	-0.0293	-2.4100	1.6543	-14.0952	3.4768	0.0125	-0.0410
M	0.0024	-0.0026	-0.4692	0.0007	0.1908	0.0158	-0.0036	-0.1426	0.0009	-0.0158
Y	0.0037	-0.0104	-1.4317	-0.1492	-1.9123	1.8252	-0.1408	0.0679	0.8583	2.4108
L'	0.0008	-0.0085	-0.9743	-0.0144	-0.9903	0.2649	-0.0427	0.0463	0.4811	0.4784
N'	-0.0010	-0.0131	-1.0492	0.0333	-0.2093	-1.2896	0.1725	0.0509	0.0858	-1.4943

CASE 168		60 KT	3258 FT/MIN	SEA LEVEL	6500 LB	AFT CG				
	PHI	THETA	PSI	ALPHA	BETA	GAMMA	ΘMR	B1S	A1S	ΘTR
	-2.68	9.29	0.00	-23.12	0.82	32.43	17.45	7.35	-3.66	6.31
	XDOT		ZDOT	U0	V0	W0	VT0			
	85.48		-54.30	93.13	1.45	-39.75	101.27			
	U	W	Q	V	P	R	DC	DB	DA	DP
X	-0.0563	0.1707	-0.0540	0.0163	-1.0310	-0.9068	2.4868	0.7095	-0.0387	-0.2067
Z	0.1538	-0.9765	-2.2471	-0.0727	-2.6964	3.4804	-14.1195	2.9349	0.1107	-0.0314
M	-0.0069	-0.0246	-0.2457	0.0036	0.1797	0.0138	-0.0216	-0.1609	0.0022	0.0236
Y	0.0156	-0.0526	-1.7845	-0.1488	-0.0028	2.3652	-0.7263	0.1521	1.0086	2.3270
L'	0.0049	-0.0210	-1.1160	-0.0109	0.0152	0.3574	-0.2380	0.0715	0.5632	0.4737
N'	-0.0115	0.0249	-0.9909	0.0423	-0.3386	-1.5197	0.7924	-0.0520	0.0899	-1.4386

CASE 169		60 KT	-1968 FT/MIN	SEA LEVEL	6500 LB	AFT CG				
	PHI	THETA	PSI	ALPHA	BETA	GAMMA	ΘMR	B1S	A1S	ΘTR
	0.02	5.14	0.00	24.04	0.01	-18.90	8.21	1.78	-0.30	-0.03
	XDOT		ZDOT	U0	V0	W0	VT0			
	95.81		32.80	92.49	0.02	41.25	101.27			
	U	W	Q	V	P	R	DC	DB	DA	DP
X	-0.0208	0.1066	2.9723	0.0002	-1.3168	-0.1700	1.2469	0.6492	-0.0110	-0.0034
Z	0.0117	-0.9662	-1.7437	-0.0050	-1.6037	0.7475	-13.6190	3.0566	-0.0107	0.0253
M	0.0081	-0.0232	-0.6033	-0.0011	0.2062	0.0148	0.1297	-0.1559	0.0012	-0.0015
Y	-0.0040	0.0137	-1.3598	-0.1152	-2.9692	1.7747	0.1474	-0.0072	0.7838	2.5504
L'	-0.0015	0.0014	-0.7970	-0.0128	-1.5376	0.2370	0.0665	0.0176	0.4398	0.5041
N'	0.0026	-0.0312	-0.3210	0.0374	-0.0949	-1.2243	-0.1831	0.1107	0.0794	-1.5812

TABLE V-4 CONTINUED
 UH-IH STABILITY AND CONTROL DERIVATIVES -- US UNITS
 (BODY-FIXED FRL AXIS SYSTEM)

CASE 170		1 KT		LEVEL FLIGHT AT SEA LEVEL			9500 LB	MID CG		
	PHI	THETA	PSI	ALPHA	BETA	GAMMA	ΘHR	B1S	A1S	ΘTR
	-1.09	4.88	0.00	4.88	-0.09	0.00	15.40	-0.08	-1.74	7.54
	XDOT	ZDOT	U0	V0	W0	VT0				
	1.69	0.00	1.68	-0.00	0.14	1.69				
	U	W	Q	V	P	R	DC	DB	DA	DP
X	-0.0056	0.0257	0.7239	-0.0088	-1.2613	-0.3445	0.7171	1.0530	-0.0067	-0.0025
Z	-0.0716	-0.3286	0.3006	-0.0819	-0.3884	2.1871	-8.4218	0.2867	0.0094	0.0125
M	0.0024	-0.0040	-0.3135	0.0020	0.2504	0.0371	-0.0054	-0.2034	0.0012	0.0176
Y	0.0159	-0.0039	-1.2220	-0.0439	-1.0526	0.7632	-0.2717	0.0120	0.8937	1.4243
L'	0.0098	-0.0049	-0.9162	-0.0160	-0.7415	0.1608	-0.1305	0.0083	0.6396	0.4685
M'	-0.0012	-0.0062	-0.1973	0.0210	-0.3041	-0.7102	0.4725	-0.0004	0.0933	-1.1645

CASE 171		60 KT		LEVEL FLIGHT AT SEA LEVEL			9500 LB	MID CG		
	PHI	THETA	PSI	ALPHA	BETA	GAMMA	ΘHR	B1S	A1S	ΘTR
	-0.62	4.72	0.00	4.72	-0.05	0.00	13.31	2.54	-1.64	2.49
	XDOT	ZDOT	U0	V0	W0	VT0				
	101.27	0.00	100.93	-0.09	8.33	101.27				
	U	W	Q	V	P	R	DC	DB	DA	DP
X	-0.0229	0.0590	1.6379	0.0011	-1.0467	-0.2903	0.7201	0.8650	-0.0139	-0.0562
Z	0.0059	-0.7220	-1.2690	-0.0217	-1.4984	1.9048	-9.5736	2.3676	0.0051	-0.0203
M	0.0037	-0.0015	-0.5572	0.0012	0.2217	0.0127	0.0295	-0.2113	0.0020	-0.0140
Y	0.0005	-0.0035	-1.0827	-0.1076	-1.8784	1.2511	-0.0509	0.0490	0.8827	1.6350
L'	-0.0012	-0.0048	-0.7637	-0.0206	-1.2689	0.3143	-0.0035	0.0422	0.6313	0.5383
M'	-0.0036	-0.0160	-0.0608	0.0304	-0.2160	-1.2097	0.2476	0.0628	0.0890	-1.3363

CASE 172		100 KT		LEVEL FLIGHT AT SEA LEVEL			9500 LB	MID CG		
	PHI	THETA	PSI	ALPHA	BETA	GAMMA	ΘHR	B1S	A1S	ΘTR
	-0.83	3.91	0.00	3.91	-0.06	0.00	13.97	5.08	-1.72	2.63
	XDOT	ZDOT	U0	V0	W0	VT0				
	168.78	0.00	168.39	-0.17	11.50	168.78				
	U	W	Q	V	P	R	DC	DB	DA	DP
X	-0.0402	0.0737	1.8240	0.0052	-0.8996	-0.3230	0.8795	0.6515	-0.0136	-0.1342
Z	0.0736	-0.8133	-3.0131	-0.0234	-2.4281	2.0887	-10.7498	4.2057	0.0263	-0.0215
M	0.0052	-0.0038	-0.7303	0.0004	0.2028	0.0183	0.0179	-0.2183	0.0020	0.0004
Y	0.0030	-0.0149	-1.0598	-0.1551	-1.8925	1.6687	-0.1891	0.1210	0.9065	2.0891
L'	0.0014	-0.0130	-0.7610	-0.0240	-1.2568	0.4291	-0.1051	0.0959	0.6472	0.6898
M'	0.0004	-0.0171	-0.1844	0.0364	-0.1644	-1.6042	0.2225	0.0975	0.0909	-1.7044

TABLE V-4 CONTINUED
UH-1H STABILITY AND CONTROL DERIVATIVES -- US UNITS
(BODY-FIXED FRL AXIS SYSTEM)

CASE 173		1 KT		LEVEL FLIGHT AT SEA LEVEL			9500 LB	FWD CG		
	PHI	THETA	PSI	ALPHA	BETA	GAMMA	ΘMR	B1S	A1S	ΘTR
	-1.09	1.95	0.00	1.95	-0.04	0.00	15.38	-2.92	-1.70	7.50
	XDOT	ZDOT	U0	V0	W0	VTO				
	1.69	0.00	1.69	-0.00	0.06	1.69				
	U	W	Q	V	P	R	DC	DB	DA	DP
X	-0.0090	0.0092	0.7123	-0.0134	-1.2843	-0.2620	0.2682	1.0643	-0.0055	-0.0033
Z	-0.1014	-0.3320	0.3720	-0.0796	-0.2080	2.2273	-8.4448	0.3099	0.0291	0.0723
H	0.0024	-0.0041	-0.3168	0.0020	0.2500	0.0276	-0.0017	-0.2027	0.0012	0.0183
Y	0.0150	-0.0040	-1.2216	-0.0437	-1.0492	0.7790	-0.2728	0.0151	0.8931	1.4242
L'	0.0091	-0.0049	-0.8501	-0.0157	-0.7351	0.1636	-0.1298	0.0105	0.6350	0.4624
N'	-0.0016	-0.0062	0.3018	0.0215	-0.2963	-0.7273	0.4779	0.0007	0.0827	-1.1804

CASE 174		60 KT		LEVEL FLIGHT AT SEA LEVEL			9500 LB	FWD CG		
	PHI	THETA	PSI	ALPHA	BETA	GAMMA	ΘMR	B1S	A1S	ΘTR
	-0.60	1.99	0.00	1.99	-0.02	0.00	13.34	-0.12	-1.59	2.45
	XDOT	ZDOT	U0	V0	W0	VTO				
	101.27	0.00	101.21	-0.04	3.53	101.27				
	U	W	Q	V	P	R	DC	DB	DA	DP
X	-0.0218	0.0250	1.5839	0.0001	-1.1213	-0.1740	0.2486	0.9905	-0.0083	-0.0552
Z	-0.0231	-0.7238	-1.3708	-0.0205	-1.3243	2.0088	-9.6062	2.3681	0.0193	0.0143
H	0.0039	-0.0023	-0.5744	0.0012	0.2199	0.0083	0.0279	-0.2099	0.0012	-0.0131
Y	0.0001	-0.0033	-1.0837	-0.1082	-1.8721	1.2966	-0.0445	0.0552	0.8969	1.6333
L'	-0.0016	-0.0046	-0.6990	-0.0190	-1.2556	0.3233	0.0018	0.0469	0.6376	0.5309
N'	-0.0043	-0.0159	0.4127	0.0322	-0.1923	-1.2436	0.2524	0.0664	0.0815	-1.3546

CASE 175		8 KT		780 FT/MIN	SEA LEVEL	9500 LB	FWD CG			
	PHI	THETA	PSI	ALPHA	BETA	GAMMA	ΘMR	B1S	A1S	ΘTR
	-1.31	2.75	0.00	-87.25	1.31	90.00	16.18	-2.19	-1.98	8.32
	XDOT	ZDOT	U0	V0	W0	VTO				
	0.00	-13.00	0.62	0.30	-12.98	13.00				
	U	W	Q	V	P	R	DC	DB	DA	DP
X	-0.0199	0.0167	0.7766	-0.0150	-1.2582	-0.2141	0.3999	1.0708	-0.0078	-0.0292
Z	-0.0378	-0.3689	-0.2349	-0.0921	-0.3852	2.4191	-8.4445	0.3024	0.0556	0.1523
H	0.0035	-0.0077	-0.3554	0.0012	0.2425	0.0359	-0.0214	-0.2034	0.0018	0.0443
Y	0.0131	-0.0197	-1.5644	-0.0487	-0.9927	0.8354	-0.3273	0.0141	0.9073	1.4672
L'	0.0083	-0.0110	-0.9696	-0.0175	-0.6255	0.1974	-0.1592	0.0096	0.6452	0.4798
N'	-0.0001	0.0069	0.4342	0.0219	-0.3938	-0.8948	0.5437	-0.0027	0.0838	-1.2141

TABLE V-4 CONTINUED
UH-1H STABILITY AND CONTROL DERIVATIVES -- US UNITS
(BODY-FIXED FRL AXIS SYSTEM)

CASE 176		60 KT		1650 FT/MIN		SEA LEVEL		9500 LB		FWD CG	
	PHI	THETA	PSI	ALPHA	BETA	GAMMA	ΘMR	BIS	AIS	ΘTR	
	-1.26	0.29	0.00	-15.46	0.34	15.76	16.37	-0.87	-2.74	5.68	
	XDOT	ZDOT	UO	VO	WO	VT0					
	97.46	-27.50	97.60	0.60	-27.00	101.27					
	U	W	Q	V	P	R	DC	DB	DA	DP	
X	-0.0243	0.0236	1.0625	0.0014	-1.1480	-0.1766	0.0243	1.1030	-0.0100	-0.1274	
Z	-0.0164	-0.6854	-1.4108	-0.0343	-1.3526	2.6837	-9.5310	2.2367	0.0474	-0.0155	
M	0.0058	0.0091	-0.4027	0.0021	0.2175	-0.9120	0.0583	-0.2257	0.0013	0.0053	
Y	0.0040	-0.0184	-1.2511	-0.1192	-1.1703	1.5175	-0.2690	0.0856	0.9517	1.5988	
L*	-0.0020	-0.0141	-0.7795	-0.0158	-0.7762	0.3708	-0.1133	0.0597	0.6760	0.5248	
N*	-0.0078	0.0046	0.6527	0.0351	-0.2965	-1.3815	0.5702	0.0022	0.0829	-1.3236	

CASE 177		60 KT		-1524 FT/MIN		SEA LEVEL		9500 LB		FWD CG	
	PHI	THETA	PSI	ALPHA	BETA	GAMMA	ΘMR	BIS	AIS	ΘTR	
	-0.01	1.53	0.00	16.06	-0.00	-14.53	10.56	-1.35	-0.63	0.06	
	XDOT	ZDOT	UO	VO	WO	VT0					
	98.03	25.40	97.32	-0.00	28.02	101.27					
	U	W	Q	V	P	R	DC	DB	DA	DP	
X	-0.0177	0.0239	2.2622	-0.0014	-1.1425	-0.1243	0.1017	0.9586	-0.0114	-0.0044	
Z	-0.0434	-0.6765	-1.5106	-0.0083	-0.9941	1.4224	-9.2902	2.1143	0.0069	0.0024	
M	0.0035	-0.0078	-0.6584	0.0004	0.2239	0.0213	0.0465	-0.1998	0.0016	-0.0028	
Y	-0.0037	0.0098	-1.0208	-0.1035	-2.4067	1.2182	0.1249	0.0038	0.8346	1.7236	
L*	-0.0027	0.0032	-0.6528	-0.0213	-1.6110	0.2875	0.0870	0.0161	0.5934	0.5590	
N*	-0.0014	-0.0278	0.4785	0.0318	-0.0837	-1.2268	-0.0030	0.1038	0.0754	-1.4303	

CASE 178		1 KT		LEVEL FLIGHT AT SEA LEVEL		9500 LB		AFT CG		
	PHI	THETA	PSI	ALPHA	BETA	GAMMA	ΘMR	BIS	AIS	ΘTR
	-1.10	7.82	0.00	7.82	-0.15	0.00	15.39	2.77	-1.78	7.55
	XDOT	ZDOT	UO	VO	WO	VT0				
	1.69	0.00	1.67	-0.00	0.23	1.69				
	U	W	Q	V	P	R	DC	DB	DA	DP
X	-0.0056	0.0416	0.7141	-0.0157	-1.2257	-0.4226	1.1654	1.0424	-0.0100	-0.0113
Z	-0.0418	-0.3237	0.2701	-0.0987	-0.5286	2.1866	-8.3642	0.3030	0.0281	0.0669
M	0.0015	-0.0047	-0.3143	-0.0050	0.2508	-0.0329	-0.0087	-0.2044	0.0015	0.0183
Y	0.0168	-0.0038	-1.2332	-0.0422	-1.0564	0.7488	-0.2692	0.0122	0.8940	1.4264
L*	0.0105	-0.0048	-0.9905	-0.0196	-0.7484	0.1690	-0.1300	0.0094	0.6441	0.4764
N*	-0.0007	-0.0062	-0.7027	0.0201	-0.3114	-0.6916	0.4690	-0.0012	0.1047	-1.1484

TABLE V-4 CONCLUDED
UH-1H STABILITY AND CONTROL DERIVATIVES -- US UNITS
(BODY-FIXED FRL AXIS SYSTEM)

CASE 179		60 KT	LEVEL FLIGHT AT SEA LEVEL			9500 LB	AFT CG			
	PHI	THETA	PSI	ALPHA	BETA	GAMMA	QMR	BIS	AIS	QTR
	-0.64	7.41	0.00	7.41	-0.04	0.00	13.27	5.19	-1.69	2.53
	XDOT	ZDOT	UO	VO	WO	VTO				
	101.27	0.00	100.42	-0.15	13.05	101.27				
	U	W	Q	Y	P	R	DC	DB	DA	DP
X	-0.0270	0.0927	1.6883	0.0023	-0.9537	-0.3978	1.1919	0.7455	-0.0157	-0.0558
Z	0.0349	-0.7176	-1.1629	-0.0227	-1.6420	1.8021	-9.5198	2.3808	0.0016	-0.0245
M	0.0033	-0.0008	-0.5432	0.0012	0.2222	0.0159	0.0303	-0.2140	0.0024	-0.0163
Y	0.0009	-0.0037	-1.0749	-0.1071	-1.9798	1.2156	-0.0531	0.0501	0.8723	1.6372
L*	-0.0009	-0.0050	-0.8229	-0.0221	-1.2789	0.3107	-0.0056	0.0432	0.6280	0.5456
N*	-0.0029	-0.0160	-0.5292	0.0287	-0.2385	-1.1749	0.2451	0.0627	0.0989	-1.3186

CASE 180		60 KT	1902 FT/MIN	SEA LEVEL	9500 LB	AFT CG				
	PHI	THETA	PSI	ALPHA	BETA	GAMMA	QMR	BIS	AIS	QTR
	-1.42	8.25	0.00	-9.99	0.25	18.24	16.64	6.14	-3.01	6.14
	XDOT	ZDOT	UO	VO	WO	VTO				
	96.18	-31.70	99.73	0.44	-17.57	101.27				
	U	W	Q	Y	P	R	DC	DB	DA	DP
X	-0.0317	0.0950	1.1180	0.0067	-0.9009	-0.5630	1.2354	0.8491	-0.0190	-0.1313
Z	0.0572	-0.6957	-1.4918	-0.0382	-1.7709	2.4932	-9.4663	2.2860	0.0368	-0.0520
M	0.0049	-0.0036	-0.4012	0.0020	0.2417	0.0075	-0.0256	-0.2090	0.0028	-0.0038
Y	0.0075	-0.0193	-1.2355	-0.1164	-1.1382	1.3941	-0.2908	0.0915	0.9504	1.5991
L*	0.0022	-0.0128	-0.8798	-0.0188	-0.7514	0.3657	-0.1508	0.0739	0.6843	0.5365
N*	-0.0087	0.0051	-0.5802	0.0306	-0.3342	-1.2843	0.5879	-0.0004	0.1055	-1.2857

CASE 181		60 KT	-1554 FT/MIN	SEA LEVEL	9500 LB	AFT CG				
	PHI	THETA	PSI	ALPHA	BETA	GAMMA	QMR	BIS	AIS	QTR
	-0.03	6.32	0.00	21.14	-0.01	-14.82	10.48	3.39	-0.70	0.14
	XDOT	ZDOT	UO	VO	WO	VTO				
	97.90	25.90	94.45	-0.02	36.52	101.27				
	U	W	Q	Y	P	R	DC	DB	DA	DP
X	-0.0186	0.0778	2.3773	-0.0010	-1.0237	-0.2595	0.9196	0.7776	-0.0073	-0.0158
Z	-0.0008	-0.6523	-1.2184	-0.0086	-1.2044	1.2909	-9.1659	2.1368	0.0155	0.0400
M	0.0069	-0.0197	-0.6444	-0.0023	0.2261	0.0216	0.0696	-0.2109	0.0008	-0.0039
Y	-0.0039	0.0097	-1.0071	-0.0933	-2.3319	1.1783	0.1193	0.0171	0.8367	1.7204
L*	-0.0026	0.0033	-0.7566	-0.0213	-1.6240	0.2729	0.0983	0.0249	0.6025	0.5718
N*	0.0009	-0.0273	-0.3562	0.0108	-0.1187	-1.1577	0.0007	0.1017	0.0064	-1.3863

TABLE V-5
UH-IH TRANSFER FUNCTION FACTORS

CASE 119 -40 KT BAR OFF

DENOMINATOR: (0) (-.173) (.409) (-.809) (2.00) [-.282; .347] [.657; 1.04] <.0150>

CONTROL NUMERATORS:

PHI/DA .562 (0) (-1.01) (1.90) [-.156; .310] [.572; .773] <-.0619>
THE/DB -.174 (0) (-.00286) (-.175) (.752) (-.814) (.922) (1.97) <.974E-4>
PSI/DP -1.24 (.797) [-.124; .331] [-.288; .451] [.706; .903] <-.0180>

PHI/DB -.0263 (0) (.0773) (-.286) (2.13) (-4.48) [-.749; 1.10] <-.00672>
THE/DA .120 (0) (.00491) (-.140) (.798) (-.878) (1.89) <.000109>

PHI/DA ;THE/DB -.0979 (0) (-.00234) (.809) (-1.00) (1.90) <-.000353>
PHI/DA ;PSI/DP -.729 (-.00176) [-.146; .325] [.575; .750] <.760E-4>
THE/DB ;PSI/DP .217 (-.00244) (.706) (1.28) [-.215; .465] <-.000103>

PHI/DB ;PSI/DP .0425 (-.0121) (-1.74) (-2.23) [-.524; .113] <-.256E-4>
PHI/DP ;THE/DB -.0606 (0) (-.00244) (.692) [.00866; 1.46] <.000217>
PHI/DC ;THE/DB .0234 (0) (-.00435) (1.66) [-.616; 1.46] <-.000361>

THE/DA ;PSI/DP -.154 (0) (.688) [.0337; .336] <-.0120>
THE/DP ;PHI/DA .00932 (0) (0) (.409) (2.32) (-2.86) <-.0252>
THE/DC ;PHI/DA -.0182 (0) (.00990) (-1.09) (1.85) (3.33) <.00121>

PSI/DA ;THE/DB -.0148 (-.00234) (.811) (2.28) [-.446; 1.62] <.000168>
PSI/DB ;PHI/DA -.0134 (-.00478) (.273) (-.448) [-.228; 2.66] <-.555E-4>
XD/DB ;PHI/DA .592 (0) (.719) (-1.00) (1.90) [-.0423; 2.43] <-.4.79>

YD/DA ;THE/DB -.152 (-.00234) (.809) (-1.01) (1.89) [-.00414; 4.54] <-.0113>
ZD/DB ;PHI/DA -.924 (0) (-.0822) (-1.00) (1.94) [.0207; 2.37] <-.831>
XD/DC ;PHI/DA .0522 (0) (-1.11) (1.79) (2.44) [-.328; 3.95] <-.3.95>

YD/DP ;THE/DB -.294 (-.00244) (.692) [-.174; 1.59] [.278; 2.36] <.00697>
ZD/DC ;PHI/DA -5.87 (0) (.0231) (-1.03) (1.87) [.0352; .850] <.189>

PHI/DA ;THE/DB ;PSI/DP .127 (.789) [-.970; .00211] <.449E-6>
PHI/DC ;THE/DB ;PSI/DP -.0144 (0) (-.00982) (-2.51) <-.000354>
THE/DC ;PHI/DA ;PSI/DP .0211 (-.00195) (.0103) (3.62) <-.153E-5>

PSI/DC ;PHI/DA ;THE/DB -.0259 (0) (0) (1.24) <-.0321>
XD/DB ;PHI/DA ;PSI/DP -.767 (-.00162) (.704) [-.0430; 2.43] <.00517>
YD/DA ;THE/DB ;PSI/DP .215 (-.00248) (.788) [-.00578; 4.37] <-.00799>

ZD/DC ;PHI/DA ;THE/DB .992 (0) (.00818) (-1.00) (1.87) <-.0152>
ZD/DC ;PHI/DA ;PSI/DP 7.62 (.00139) (.0386) [.0132; .822] <.000276>
XD/DC ;PHI/DA ;THE/DB .0100 (0) (-1.03) (1.90) (5.94) <-.116>

XD/DC ;PHI/DA ;PSI/DP -.0739 (-.00266) (2.35) [-.333; 3.76] <.00654>
YD/DP ;PHI/DA ;THE/DB -.112 (-.00276) (-.289) [.988; .582] <-.303E-4>
ZD/DB ;PHI/DA ;PSI/DP 1.20 (-.00151) (-.0798) [.0191; 2.37] <.000807>

ZD/DC ;PHI/DA ;THE/DB ;PSI/DP -1.29 (-.00176) (.00784) <.178E-4>
XD/DC ;PHI/DA ;THE/DB ;PSI/DP -.00931 (-.00187) (8.19) <.000142>

TABLE V-5 CONTINUED
UH-IH TRANSFER FUNCTION FACTORS

CASE 119 -40KT BAR ON

DENOMINATOR: (0) (-.0270) (.604) (-.930) (1.94) [-.120; .150][-.183; 1.13][-.309; 1.99]<-.00338>

CONTROL NUMERATORS:

PHI/DA .562 (0) (.333) (.610) (-1.01) (1.90) [.103; .151][.203; 1.18]<-.00688>
 THE/DB -.174 (0) (-.00262) (-.0253) (.333) (.810) (-.928) (1.92) [.317; 1.91]<-.202E-4>
 PSI/DP -1.24 (.602)[.229; .143][-.0903; .160][.179; 1.13][.325; 2.00]<-.00200>

PHI/DB -.0263 (0) (.0733) (-.297) (.329) (.333) (2.15) (-4.51) [-.727; 1.11]<-.000744>
 THE/DA .120 (0) (.00224) (-.197) (.333) (.384) (.797) (-.857) (1.89)<.870E-5>

PHI/DA ; THE/DB -.0979 (0) (-.00234) (.333) (.333) (.809) (-1.00) (1.90)<-.392E-4>
 PHI/DA ; PSI/DP -.729 (-.00176) (.333) (.605) [-.121; .154][.196; 1.17]<.845E-5>
 THE/DB ; PSI/DP .217 (-.00244) (.333) (.798) [.195; .150][.331; 1.91]<-.115E-4>

PHI/DB ; PSI/DP .0425 (-.0121) (.332) (.333) (-1.70) (-2.28) [-.528; .114]<-.284E-5>
 PHI/DP ; THE/DB -.0606 (0) (-.00244) (-.278) (.333) (.712) [.0194; 1.57]<.241E-4>
 PHI/DC ; THE/DB .0234 (0) (-.00434) (-.319) (.333) (1.65) [-.591; 1.50]<-.400E-4>

THE/DA ; PSI/DP -.154 (0) (.333) (.333) (.688) [.0337; .336]<-.00133>
 THE/DP ; PHI/DA .00932 (0) (0) (.235) (.333) (.515) (2.47) (-3.01)<-.00279>
 THE/DC ; PHI/DA -.0182 (0) (-.00990) (-.329) (.333) (-1.11) (1.84) (3.36)<.000135>

PSI/DA ; THE/DB -.0148 (-.00234) (.333) (.333) (.811) (2.28) [-.446; 1.62]<.186E-4>
 PSI/DB ; PHI/DA -.0134 (-.00478) (-.273) (.333) (.333) (-.448) [-.228; 2.66]<-.617E-5>
 XD/DB ; PHI/DA .592 (0) (.333) (.333) (-.719) (-1.00) (1.90) [-.0423; 2.43]<-.532>

YD/DA ; THE/DB -.152 (-.00234) (.333) (.333) (.809) (-1.01) (1.89) [-.00414; 4.54]<-.00126>
 ZD/DB ; PHI/DA -.924 (0) (-.0822) (.333) (.333) (-1.00) (1.94) [.0207; 2.37]<-.0924>
 XD/DC ; PHI/DA .0522 (0) (.333) (.390) (-1.13) (1.71) (2.38) [-.332; 3.74]<-.439>

YD/DP ; THE/DB -.294 (-.00244) (.283) (.333) (-.707) [-.0845; 1.43][.182; 2.83]<.000775>
 ZD/DC ; PHI/DA -5.87 (0) (-.0248) (.146) (.333) (-1.03) (1.88) [-.0962; 1.24]<.0210>

PHI/DA ; THE/DB ; PSI/DP .117 (0) (.333) (.333) [-.970; .00211]<.582E-7>
 PHI/DC ; THE/DB ; PSI/DP -.0144 (0) (-.00982) (.333) (.333) (-2.51)<-.393E-4>
 THE/DC ; PHI/DA ; PSI/DP .0211 (-.00195) (-.0103) (.333) (.333) (3.62)<-.170E-6>

PSI/DC ; PHI/DA ; THE/DB -.0259 (.333) (.333) (1.24) [.354; .00325]<-.375E-7>
 XD/DB ; PHI/DA ; PSI/DP -.767 (-.00162) (.333) (.333) (-.704) [-.0430; 2.43]<.000575>
 YD/DA ; THE/DB ; PSI/DP .215 (-.00248) (.333) (.333) (.788) [-.00578; 4.37]<-.000888>

ZD/DC ; PHI/DA ; THE/DB .992 (0) (.00818) (.333) (.333) (-1.00) (1.87)<-.00169>
 ZD/DC ; PHI/DA ; PSI/DP 7.62 (.00139) (.0473) (.123) (.333) [.0915; 1.22]<.307E-4>
 XD/DC ; PHI/DA ; THE/DB -.0100 (0) (.333) (.333) (-1.03) (1.90) (5.94)<-.0129>

XD/DC ; PHI/DA ; PSI/DP -.0739 (-.00266) (.333) (.398) (2.17) [-.333; 3.58]<.000727>
 YD/DP ; PHI/DA ; THE/DB -.112 (-.00276) (-.289) (.333) (.333) [-.988; .582]<-.337E-5>
 ZD/DB ; PHI/DA ; PSI/DP 1.20 (-.00151) (-.0798) (.333) (.333) [.0191; 2.37]<.897E-4>

ZD/DC ; PHI/DA ; THE/DB ; PSI/DP -1.29 (-.00176) (-.00784) (.333) (.333)<.198E-5>
 XD/DC ; PHI/DA ; THE/DB ; PSI/DP -.00931 (-.00187) (.333) (.333) (8.19)<.158E-4>

TABLE V-5 CONTINUED
UH-IH TRANSFER FUNCTION FACTORS

CASE I20 -20KT BAR OFF

DENOMINATOR: (0) (.346) (1.39) [-.683;.437][-.420;.593][-.811;.856]<.0236>

CONTROL NUMERATORS:

PHI/LA .555 (0) (-.567) (1.23) [-.449;.571][.910;.617]<-.0481>
THE/DB -.168 (0) (-.0430) (1.43) [-.673;.445][.974;.580]<.000689>
PSI/DP -1.04 (.412) [-.220;.479][-.406;.592][.910;.925]<-.0294>

PHI/DB -.0163 (0) (.102) (-.658) (1.28) (-8.16) [-.123;.632]<-.00459>
THE/DA .125 (0) (-.0284) (.559) (1.21) [-.727;.403]<-.000389>

PHI/DA ;THE/DB -.0932 (0) (-.0417) (.539) (-.575) (1.23) <-.00148>
PHI/DA ;PSI/DP -.603 (0) [-.435;.587][.921;.605]<-.0760>
THE/DA ;PSI/DP .174 (-.0428) (.458) (1.10) [-.221;.483]<-.000876>

PHI/DB ;PSI/DP .0184 (-7.08) [.0351;.0268][-.166;.538]<-.269E-4>
PHI/DP ;THE/DB -.0524 (0) (-.0428) (.425) [.0530;.981]<.000918>
PHI/DC ;THE/DB .0198 (0) (-.0429) (.926) [-.568;1.15]<-.00104>

THE/DA ;PSI/DP -.134 (-.0268) (.480) [.00377;.424]<.000308>
THE/DP ;PHI/DA .00610 (0) (-.0268) (.369) (1.61) (-3.33) <.000323>
THE/DC ;PHI/DA -.00181 (0) (-.0275) (1.12) (-1.18) (6.42) <-.000423>

PSI/DA ;THE/DB -.0146 (-.0418) (.535) (1.82) [-.457;1.54] <.00141>
PSI/DB ;PHI/DA -.0227 (-.00432) (.319) (-.827) (1.90) <-.492E-4>
XD/DB ;PHI/DA .576 (0) (.529) (-.575) (1.23) [-.0107;2.29] <-1.13>

YD/DA ;THE/DB -.144 (-.0417) (.539) (-.582) (1.22) [-.00379;4.55] <-.0477>
ZD/DB ;PHI/DA -.376 (0) (-.479) (-.566) (1.25) [-.0156;2.11] <-.568>
XD/DC ;PHI/DA .0241 (0) (1.11) (-1.18) (3.16) [-.203;2.24] <-.500>

YD/DP ;THE/DB -.237 (-.0428) (.425) [.0196;1.03][.113;2.53] <.0296>
ZD/DC ;PHI/DA -5.18 (0) (.510) (-.566) (1.17) [-.382;.556] <.542>

PHI/DA ;THE/DB ;PSI/DP .101 (0) (-.0425) (.524) <-.00226>
PHI/DC ;THE/DB ;PSI/DP -.00264 (-.00670) (-.0428) (-8.54) <.647E-5>
THE/DC ;PHI/DA ;PSI/DP .0153 (-.00539) (-.0281) <.232E-5>

PSI/DC ;PHI/DA ;THE/DB -.0336 (.00956) (-.0435) (.653) <.913E-5>
XD/DB ;PHI/DA ;PSI/DP -.626 (0) (.515) [-.0120;2.29] <-1.70>
YD/DA ;THE/DB ;PSI/DP .171 (-.0426) (-.523) [-.00701;4.37] <-.0725>

ZD/DC ;PHI/DA ;THE/DB .868 (0) (-.0376) (-.569) (1.17) <.0217>
ZD/DC ;PHI/DA ;PSI/DP 5.62 (.00148) (.565) [-.397;.595] <.00167>
XD/DC ;PHI/DA ;THE/DB -.00217 (0) (1.25) [-.975;1.42] <-.00543>

XD/DC ;PHI/DA ;PSI/DP -.0361 (-.00554) (3.27) [-.340;2.06] <.00277>
YD/DP ;PHI/DA ;THE/DB -.0866 (-.0556) (-.0734) [.977;.332] <-.389E-4>
ZD/DB ;PHI/DA ;PSI/DP .409 (0) (-.457) [-.0197;2.08] <-.808>

ZD/DC ;PHI/DA ;THE/DB ;PSI/DP -.944 (0) (-.0407) <.0384>
XD/DC ;PHI/DA ;THE/DB ;PSI/DP .00630 (-.00577) (-.848) <.308E-4>

TABLE V-5 CONTINUED
UH-IH TRANSFER FUNCTION FACTORS

CASE I20 -20KT BAR ON

DENOMINATOR: (0) (-.0835) (-.441) (.492) (1.27) [.250;-.316][.158;-.877][.262;1.94]<.00666>

CONTROL NUMERATORS:

PHI/DA .555 (0) (.333) (.494) (-.569) (1.23) [.236;.323][.168;.894]<-.00535>
THE/DB -.168 (0) (-.0431) (-.0747) (.333) (-.454) (.537) (1.27) [.270;1.88]<.000197>
PSI/DP -1.04 (.489)[.235;.143][.279;.326][.140;.879][.278;1.96]<-.00327>

PHI/DB -.0163 (0) (.0862) (.330) (.333) (-.669) (1.29) (-8.18) [-.0909;.679]<-.000506>
THE/DA .125 (0) (-.0333) (.333) (.410) (.571) (1.19) [-.707;.455]<-.798E-4>

PHI/DA ; THE/DB -.0932 (0) (-.0417) (.333) (.333) (.539) (-.575) (1.23) <-.000164>
PHI/DA ; PSI/DP -.603 (0) (.333) (.488) [-.287;.328][.146;.895]<-.00844>
THE/DB ; PSI/DP .174 (-.0428) (.333) (.529) [.213;.143][.285;1.90]<-.973E-4>

PHI/DB ; PSI/DP .0184 (.332) (.333) (-7.09) [-.0347;.0268][-.159;.538]<-.299E-5>
PHI/DP ; THE/DB -.0524 (0) (-.0428) (.194) (.333) (.483) [.0771;1.21]<.000102>
PHI/DC ; THE/DB .0198 (0) (-.0429) (.294) (.333) (.878) [-.483;1.26]<-.000116>

THE/DA ; PSI/DP -.134 (-.0268) (.333) (.333) (.480) [-.00377;.424]<.343E-4>
THE/DP ; PHI/DA .00610 (0) (-.0272) (.214) (.333) (.452) (1.88) (-3.57) <.359E-4>
THE/DC ; PHI/DA -.00181 (0) (-.0276) (.312) (.333) (1.05) (-1.30) (6.63) <-.472E-4>

PSI/DA ; THE/DB -.0146 (-.0418) (.333) (.333) (.535) (1.82) [-.457;1.54]<.000157>
PSI/DB ; PHI/DA -.0227 (-.00432) (.319) (.333) (.333) (-.827) (1.90) <-.547E-5>
XD/DB ; PHI/DA .576 (0) (.333) (.333) (.529) (-.575) (1.23) [-.0107;2.29]<-.126>

YD/DA ; THE/DB -.144 (-.0417) (.333) (.333) (.539) (-.582) (1.22) [-.00379;4.55]<-.00529>
ZD/DB ; PHI/DA -.376 (0) (.333) (.333) (-.479) (-.566) (1.25) [-.0156;2.11]<-.0631>
XD/DC ; PHI/DA .0241 (0) (.333) (.337) (1.01) (-1.30) (3.22) [-.170;2.21]<-.0557>

YD/DP ; THE/DB -.237 (-.0428) (.195) (.333) (.477) [.0240;1.10][.110;2.94]<.00328>
ZD/DC ; PHI/DA -5.18 (0) (.333) (-.567) (1.17) [.304;.248][.144;.923]<.0602>

PHI/DA ; THE/DB ; PSI/DP .101 (0) (-.0425) (.333) (.333) (.524) <-.000251>
PHI/DC ; THE/DB ; PSI/DP -.00264 (-.00670) (-.0428) (.333) (.333) (-8.54) <.719E-6>
THE/DC ; PHI/DA ; PSI/DP .0153 (-.00539) (-.0281) (.333) (.333) <.258E-6>

PSI/DC ; PHI/DA ; THE/DB -.0336 (.00956) (-.0435) (.333) (.333) (.653) <.101E-5>
XD/DB ; PHI/DA ; PSI/DP -.626 (0) (.333) (.333) (-.515) [-.0120;2.29]<-.188>
YD/DA ; THE/DB ; PSI/DP .171 (-.0426) (.333) (.333) (.523) [-.00701;4.37]<-.00806>

ZD/DC ; PHI/DA ; THE/DB .868 (0) (-.0376) (.333) (.333) (-.569) (1.17) <.00241>
ZD/DC ; PHI/DA ; PSI/DP 5.62 (.00148) (.333) [.378;.284][.116;.909]<.000185>
XD/DC ; PHI/DA ; THE/DB -.00217 (0) (.333) (.333) (1.25) [-.975;1.42]<-.000604>

XD/DC ; PHI/DA ; PSI/DP -.0361 (-.00554) (.333) (.360) (3.06) [-.296;2.05]<.000308>
YD/DP ; PHI/DA ; THE/DB -.0866 (-.0556) (-.0734) (.333) (.333) [.977;.332]<-.432E-5>
ZD/DB ; PHI/DA ; PSI/DP .409 (0) (.333) (.333) (-.457) [-.0197;2.08]<-.0898>

ZD/DC ; PHI/DA ; THE/DB ; PSI/DP -.944 (0) (-.0407) (.333) (.333) <.00427>
XD/DC ; PHI/DA ; THE/DB ; PSI/DP .00630 (-.00577) (.333) (.333) (-.848) <.343E-5>

TABLE V-5
UH-IH TRANSFER FUNCTION FACTORS

CASE I22 HOVER BAR OFF

DENOMINATOR: (0) (.467) (.944) [-.371; .462] [-.152; .551] [.796; .631] <.0114>
HD P PL

CONTROL NUMERATORS:

PHI/DA .569 (0) (.0645) (.677) [-.446; .380] [.897; .506] <.000920>
THE/DB -.169 (0) (-.00817) (1.06) [.959; .415] [-.138; .552] <.771E-4>
PSI/DP -1.20 (.704) [-.104; .431] [-.464; .478] [.834; .666] <-.0159>

PHI/DB .157 (0) (.0594) [-.0503; .511] [.977; .567] <.000779>
PHI/DP .339 (0) (-.152) (.276) [-.364; .400] [.794; .578] <-.000760>
PHI/DC -.0817 (0) (-.0405) (.519) [.604; .409] [-.754; .758] <.000165>

THE/DA .134 (0) (-.00762) (.375) (.766) [-.0339; .575] <-.969E-4>
THE/DP -.00660 (0) (.00129) (-8.73) [.675; .465] [.0303; .539] <.466E-5>
THE/DC .00491 (0) (.0167) (.498) [-.124; .579] [.998; 3.31] <.000150>

PSI/DA .0829 (1.29) [-.426; .386] [-.941; .521] [-.701; 1.94] <.0162>
PSI/DB .00222 (.535) (1.57) (5.86) [-.0553; .506] [-.943; 2.23] <.0138>
PSI/DC .437 (.404) [-.276; .324] [-.333; .629] [.919; .868] <.00556>

XD/DB 1.06 (0) (1.07) [.955; .409] [-.138; .552] [.0202; 2.27] <.297>
YD/DA .885 (.0617) (.665) [-.446; .380] [.892; .504] [.0104; 4.53] <.0273>
ZD/DC -9.79 (0) (.661) [-.251; .394] [-.205; .579] [.952; .628] <-.133>

XD/DC -.00871 (0) (.499) (-6.19) (-9.98) [-.126; .576] [.748; 1.79] <-.287>
YD/DP 1.63 (-.157) (.291) [-.364; .402] [.787; .580] [.0364; 2.57] <-.0269>
ZD/DB .247 (0) (.371) (1.30) (-1.67) [-.106; .539] [-.294; 1.52] <-.133>

PHI/DA ; THE/DB -.0962 (0) (-.00787) (.0616) (.444) (.621) <.129E-4>
PHI/DA ; PSI/DP -.711 (.00838) [-.440; .380] [.923; .492] <-.000209>
THE/DB ; PSI/DP .203 (-.0127) (.276) (.934) [-.149; .414] <-.000114>

PHI/DB ; PSI/DP -.191 (.00719) (.473) [-.0705; .506] <-.000166>
PHI/DP ; THE/DB -.0572 (0) (-.0212) (-.0371) [.850; .349] <-.548E-5>
PHI/DC ; THE/DB .0138 (0) (.0105) (.105) (.544) (-1.11) <-.917E-5>

THE/DA ; PSI/DP -.167 (-.00563) (.507) [-.106; .521] <.000129>
THE/DP ; PHI/DA -.00465 (0) (-.00516) (.193) (-.439) (3.00) <-.610E-5>
THE/DC ; PHI/DA .00301 (0) (.561) (8.89) [.766; .0301] <.136E-4>

PSI/DA ; THE/DB -.0140 (-.00787) (.418) (1.34) [-.708; 1.92] <.000228>
PSI/DB ; PHI/DA -.00813 (-.00696) (.189) [.0634; 1.10] <.130E-4>
PSI/DC ; THE/DB -.0740 (.00948) [-.371; .563] [.992; .809] <-.000145>

PSI/DC ; PHI/DA .256 (.0168) [-.442; .395] [.921; .566] <.000215>
XD/DB ; PHI/DA .604 (0) (.0616) (.430) (.626) [.0192; 2.27] <.0515>
XD/DB ; PSI/DP -1.27 (.254) (.940) [-.147; .413] [.0200; 2.27] <-.266>

YD/DA ; THE/DB -.150 (-.00787) (.0596) (.452) (.591) [.0110; 4.53] <.000384>
YD/DA ; PSI/DP -1.20 [-.440; .380] [.922; .492] [-.0114; 4.37] <-.800>
ZD/DC ; PHI/DA -5.57 (0) (.101) (.335) (.623) [-.359; .321] <-.0122>

ZD/DC ; THE/DB 1.65 (0) (.00403) (.410) (1.00) [-.183; .558] <.000853>
ZD/DC ; PSI/DP 11.7 [-.191; .377] [-.310; .491] [.910; .745] <.224>
XD/DC ; PHI/DA -.00546 (0) (.0362) (.560) (4.33) [-.433; 6.03] <-.0174>

XD/DC ; THE/DB -.0508 (0) (.423) (.954) [-.144; .535] <-.00587>
XD/DC ; PSI/DP .0119 (1.23) (6.55) [-.159; .459] [-.156; 4.78] <.463>
YD/DP ; PHI/DA .630 (.0822) (-.211) [-.448; .380] [.923; .473] <-.000352>

YD/DP ; THE/DB -.276 (-.0159) (-.0525) [.860; .357] [.0369; 2.55] <-.000192>
ZD/DB ; PHI/DA .140 (0) (.0623) (.738) (-1.54) [.343; 1.33] <-.0175>
ZD/DB ; PSI/DP -.296 (1.21) (-1.68) [-.139; .465] [.249; 1.46] <.280>

PHI/DA ; THE/DB ; PSI/DP .120 (.00765) (-.00787) (.392) <-.284E-5>
PHI/DC ; THE/DB ; PSI/DP .00851 (2.16) [.844; .0132] <.322E-5>
THE/DC ; PHI/DA ; PSI/DP -.0284 (.00270) (.0215) <-.165E-5>

TABLE V-5 CONTINUED
UH-IH TRANSFER FUNCTION FACTORS

CASE 122 HOVER BAR OFF

CONTROL NUMERATORS CONCLUDED:

PSI/DC ; PHI/DA ; THE/DB - .0432 (-.00794) (.0161) (-.510) <.282E-5>

XD/DB ; PHI/DA ; PSI/DP - .754 (.00752) (.383) [-.0193; 2.27] <-.0112>
 YD/DA ; THE/DB ; PSI/DP .202 (-.00776) (.390) [-.0107; 4.37] <-.0117>
 ZD/DC ; PHI/DA ; THE/DB .941 (0) (.00283) (.0575) (.572) <.875E-4>

ZD/DC ; THE/DB ; PSI/DP -1.98 (.00582) (.909) [-.245; .452] <-.00214>
 ZD/DC ; PHI/DA ; PSI/DP 6.95 (.00783) (.438) [-.355; .336] <.00269>
 XD/DC ; PHI/DA ; THE/DB - .0290 (0) (-.0612) (.565) <-.00100>

XD/DC ; PHI/DA ; PSI/DP .00676 (.0137) (4.57) [-.486; 5.45] <.0125>
 XD/DC ; THE/DB ; PSI/DP .0528 (.885) [-.244; .383] <.00685>
 YD/DP ; PHI/DA ; THE/DB - .107 (-.00799) (.0743) (-.211) (.359) <-.479E-5>

ZD/DB ; PHI/DA ; PSI/DP - .175 (.00828) (-1.51) [.347; 1.34] <.00396>

ZD/DC ; PHI/DA ; THE/DB ; PSI/DP -1.17 (0) (.0111) <-.0131>
 XD/DC ; PHI/DA ; THE/DB ; PSI/DP .0311 (.00833) <.000259>

GUST NUMERATORS:

PHI/UG -.00722 (0) (0) (0) (.0690) (-.0882) [.952; .611] <.164E-4>
 THE/UG -.00157 (0) (0) (2.02) [-.0911; .571] [.990; .585] <-.000353>
 PSI/UG .00215 (0) (0) (-.104) (.622) (-.866) [.737; 1.49] <.000267>

PHI/VG .0113 (0) (0) (-.431) [-.374; .448] [.817; .602] <.000354>
 THE/VG -.00167 (0) (0) (-.0200) (.122) [.545; .379] <.585E-6>
 PSI/VG -.0208 (0) (0) (.583) [-.392; .447] [.795; .719] <-.00126>

PHI/WG .00568 (0) (0) (.0390) (-.614) (.717) [.400; .388] <-.147E-4>
 THE/WG .00406 (0) (0) (.0170) (.610) (1.19) [-.116; .568] <.162E-4>
 PSI/WG .00649 (0) (-.238) (1.07) [-.483; .264] [-.270; .995] <-.000115>

PHI/PG .586 (0) (.0668) (.963) [-.328; .446] [.923; .548] <.00225>
 THE/PG -.230 (0) (.300) (-.949) [-.913; .0351] [-.0894; .484] <-.188E-4>
 PSI/PG .372 (.924) [-.329; .449] [.961; .682] [-.509; 1.13] <.0413>

PHI/QG .880 (0) (.0722) (.620) [-.597; .280] [.892; .423] <.000552>
 THE/QG .191 (0) (0) (.402) (.643) (1.84) [-.0862; .575] <.0300>
 PSI/QG .0696 (1.38) [-.526; .294] [.957; .406] [-.879; 2.54] <.00879>

PHI/RG -.147 (0) (.270) (-.372) [-.401; .395] [.790; .508] <.000598>
 THE/RG -.0127 (0) (0) (-.0218) (.225) (2.92) [-.0237; .587] <.625E-4>
 PSI/RG .686 (.660) [-.201; .444] [-.409; .513] [.875; .696] <.0114>

XD/UG .0104 (0) (1.91) [-.0933; .569] [.987; .581] [-.0363; 2.29] <.0114>
 ZD/UG .126 (0) (0) (.0798) (1.12) [.694; .340] [-.0687; .677] <.000596>
 YD/VG .0472 (0) (.433) [-.373; .448] [.814; .601] [.0274; 2.77] <.0114>

XD/WG -.0150 (0) (0) (.618) (1.29) (7.94) [-.119; .567] <-.0306>
 ZD/WG .376 (0) (.781) [-.131; .499] [-.361; .553] [.922; .712] <.0114>

PHI/UG ; THE/DB .00123 (0) (0) (.0593) [.950; .575] <.242E-4>
 PHI/UG ; PSI/DP .00793 (0) (0) (.0130) (-.0856) (.577) <-.509E-5>
 THE/UG ; PHI/DA -.000877 (0) (0) (.0645) [.952; .711] <-.286E-4>

THE/UG ; PSI/DP .00190 (0) (.609) (1.91) [-.157; .473] <.000495>
 PSI/UG ; PHI/DA .00182 (0) (0) (-.0273) [.985; .183] <-.167E-5>
 PSI/UG ; THE/DB -.000360 (0) (.646) (-1.00) [.723; 1.36] <.000430>

PHI/VG ; THE/DB -.00190 (0) (0) (-.00817) [.955; .394] <.240E-5>
 PHI/VG ; PSI/DP -.00653 (0) [-.345; .466] [.872; .591] <-.000496>
 THE/VG ; PHI/DA -.000980 (0) (0) (-.00762) (.358) (1.13) <.302E-5>

THE/VG ; PSI/DP .00186 (0) (0) (-.00127) [.536; .484] <-.553E-6>
 PSI/VG ; PHI/DA -.0128 (0) [-.432; .391] [.931; .507] <-.000504>
 PSI/VG ; THE/DB .00353 (0) (0) (-.00857) (.386) (.792) <-.925E-5>

TABLE V-5 CONTINUED
UH-IH TRANSFER FUNCTION FACTORS
CASE I22 HOVER BAR OFF

GUST NUMERATORS CONTINUED:

PHI/WG ; THE/DB	- .000995 (0) (.0208) (.0715) (.816) <-.121E-5>
PHI/WG ; PSI/DP	- .00901 (0) (.0228) (-.527) [.330; .346] <.130E-4>
THE/WG ; PHI/DA	.00230 (0) (0) (.0133) (.0555) (.697) <.118E-5>
THE/WG ; PSI/DP	- .00483 (0) (.0175) (1.29) [-.170; .456] <-.226E-4>
PSI/WG ; PHI/DA	.00322 (0) (.0294) (.593) [-.379; .455] <.116E-4>
PSI/WG ; THE/DB	- .00111 (0) (.0192) (1.12) [-.414; .927] <-.205E-4>
PHI/PG ; THE/DB	- .0970 (0) (-.00859) (.0662) (.413) (.726) <.166E-4>
PHI/PG ; PSI/DP	- .829 (.00651) [-.337; .443] [.976; .610] <-.000393>
THE/PG ; PHI/DA	- .132 (0) (-.00721) (.0670) [-.991; .526] <.177E-4>
THE/PG ; PSI/DP	.278 (0) (-.382) (.650) [.133; .458] <-.0145>
PSI/PG ; PHI/DA	.163 (.0387) [-.638; .281] [.794; .534] <.000143>
PSI/PG ; THE/DB	- .0624 (-.00857) (.405) (1.17) [-.461; 1.09] <.000303>
PHI/QG ; THE/DB	- .150 (0) (-.00220) (.0616) (.450) (.606) <.557E-5>
PHI/QG ; PSI/DP	-1.08 (.0145) [-.576; .280] [.903; .389] <-.000186>
THE/QG ; PHI/DA	.106 (0) (.00142) (.0616) (.458) (.601) <.254E-5>
THE/QG ; PSI/DP	- .228 (0) (.445) (1.90) [-.159; .482] <-.0449>
PSI/QG ; PHI/DA	- .0334 (-.0565) (.140) (-.553) [.593; .709] <-.732E-4>
PSI/QG ; THE/DB	- .0122 (-.00210) (.419) (1.40) [-.883; 2.48] <.921E-4>
PHI/RG ; THE/DB	.0250 (0) (-.00812) (-.263) [-.977; .276] <.406E-5>
PHI/RG ; PSI/DP	- .0558 (.0267) (.291) (1.23) [-.346; .382] <-.777E-4>
THE/RG ; PHI/DA	- .00684 (0) (-.00766) (.257) [-.379; .615] <.510E-5>
THE/RG ; PSI/DP	.0198 (.00126) (.884) (-.924) [-.0523; .480] <-.467E-5>
PSI/RG ; PHI/DA	.403 (.00475) [-.444; .380] [.918; .504] <.703E-4>
PSI/RG ; THE/DB	- .116 (-.00813) (.379) (.940) [-.250; .479] <.771E-4>
XD/UG ; PHI/DA	.00590 (0) (.0645) [.956; .702] [-.0473; 2.22] <.000920>
XD/UG ; THE/DB	- .960E-4 (0) (.391) (1.24) (-5.31) [-.298; .559] <.771E-4>
XD/UG ; PSI/DP	- .0125 (.605) (1.80) [-.159; .471] [-.0393; 2.29] <-.0159>
ZD/UG ; PHI/DA	.0716 (0) (0) (.0678) (.735) [-.749; .116] <.483E-4>
ZD/UG ; THE/DB	- .0209 (0) (0) (.390) (1.17) [-.149; .659] <-.00412>
ZD/UG ; PSI/DP	- .151 (0) (.891) [-.820; .132] [-.161; .600] <-.000835>
YD/VG ; PHI/DA	.0168 (0) (.132) [-.450; .378] [.940; .472] <.703E-4>
YD/VG ; THE/DB	- .00794 (0) (-.00817) [.955; .395] [.0414; 2.76] <.771E-4>
YD/VG ; PSI/DP	- .0225 [-.346; .467] [.871; .589] [.0311; 3.05] <-.0159>
XD/WG ; PHI/DA	.00779 (0) (0) (.0583) (.697) (-9.48) <-.00300>
XD/WG ; THE/DB	- .00449 (0) (0) (.458) (1.04) [-.153; .541] <-.000629>
XD/WG ; PSI/DP	.0197 (0) (1.52) (6.76) [-.170; .453] <.0416>
ZD/WG ; PHI/DA	.214 (0) (.0650) (.534) (.705) [-.397; .420] <.000920>
ZD/WG ; THE/DB	- .0645 (0) (-.00841) (.492) (1.03) [-.162; .529] <.771E-4>
ZD/WG ; PSI/DP	- .451 [-.0460; .421] [-.486; .533] [.867; .838] <-.0159>
XD/UG ; ZD/DC	- .101 (0) (.449) (2.04) [-.0789; .546] [.0160; 2.20] <-.133>
YD/VG ; ZD/DC	- .413 (0) [-.284; .399] [.952; .503] [.0259; 2.83] <-.133>
PHI/UG ; THE/DB ; PSI/DP	- .00136 (0) (.00719) (.528) <-.516E-5>
THE/UG ; PHI/DA ; PSI/DP	.00111 (0) (.00838) (.698) <.649E-5>
PSI/UG ; PHI/DA ; THE/DB	- .000307 (0) (-.00696) (.189) <.405E-6>
PHI/VG ; THE/DB ; PSI/DP	.00109 (0) (-.0127) (.256) <-.354E-5>
THE/VG ; PHI/DA ; PSI/DP	.00112 (0) (-.00563) (.638) <-.402E-5>
PSI/VG ; PHI/DA ; THE/DB	.00216 (0) (-.00787) (.416) <-.709E-5>
PHI/WG ; THE/DB ; PSI/DP	.00157 (0) [.955; .0145] <.328E-6>
THE/WG ; PHI/DA ; PSI/DP	- .00284 (0) (.00337) (.0200) <-.191E-6>
PSI/WG ; PHI/DA ; THE/DB	- .000547 (0) (-.00804) (.0333) <.146E-6>

TABLE V-5 CONTINUED
UH-IH TRANSFER FUNCTION FACTORS

CASE 122 HOVER BAR OFF

GUST NUMERATORS CONCLUDED:

PHI/PG ; THE/DB ; PSI/DP	.138 (.00664) (-.00807) (.394) <-.290E-5>
THE/PG ; PHI/DA ; PSI/DP	.166 (.00617) (-.00766) (.389) <-.306E-5>
PSI/PG ; PHI/DA ; THE/DB	-.0275 (-.00786) (.0204) (.396) <.175E-5>
PHI/QG ; THE/DB ; PSI/DP	.185 (-.00268) (.00865) (.391) <-.168E-5>
THE/QG ; PHI/DA ; PSI/DP	-.133 (.390) [.787; .00453] <-.106E-5>
PSI/QG ; PHI/DA ; THE/DB	.00554 (-.00767) (.0622) (.402) <-.106E-5>
PHI/RG ; THE/DB ; PSI/DP	.00925 (-.00499) (.0144) (.762) <-.506E-6>
THE/RG ; PHI/DA ; PSI/DP	.0118 (-.0980) [-.417; .0244] <-.691E-6>
PSI/RG ; PHI/DA ; THE/DB	-.0681 (.00416) (-.00787) (.409) <.911E-6>
XD/UG ; PHI/DA ; THE/DB	-.674E-4 (0) (.0617) (.761) (-4.07) <.129E-4>
XD/UG ; PHI/DA ; PSI/DP	-.00737 (.00838) (.675) [-.0484; 2.24] <-.000209>
XD/UG ; THE/DB ; PSI/DP	.991E-4 (1.09) (-6.60) [-.552; .400] <-.000114>
ZD/UG ; PHI/DA ; THE/DB	-.0119 (0) (0) (.0623) (.733) <-.000543>
ZD/UG ; PHI/DA ; PSI/DP	-.0895 (0) (.00841) [.756; .121] <-.110E-4>
ZD/UG ; THE/DB ; PSI/DP	.0250 (0) (1.02) [-.280; .583] <.00870>
YD/VG ; PHI/DA ; THE/DB	-.00284 (0) (-.00789) (.103) (.394) <.911E-5>
YD/VG ; PHI/DA ; PSI/DP	-.00684 [-.474; .377] [-.899; .463] <-.000209>
YD/VG ; THE/DB ; PSI/DP	.00377 (-.0127) (.256) [.0543; 3.05] <-.000114>
XD/WG ; PHI/DA ; THE/DB	-.00255 (0) (0) (.0616) (.689) <-.000108>
XD/WG ; PHI/DA ; PSI/DP	-.00969 (0) (.0125) (-9.44) <.00114>
XD/WG ; THE/DB ; PSI/DP	.00534 (0) (.862) [-.214; .383] <.000674>
ZD/WG ; PHI/DA ; THE/DB	-.0367 (0) (-.00805) (.0616) (.708) <.129E-4>
ZD/WG ; PHI/DA ; PSI/DP	-.267 (.00838) (.531) [-.395; .419] <-.000209>
ZD/WG ; THE/DB ; PSI/DP	.0775 (-.0138) (.835) [-.199; .357] <-.000114>
XD/UG ; ZD/DC ; PHI/DA	-.0571 (0) (.101) (.459) [.0398; 2.15] <-.0122>
XD/UG ; ZD/DC ; THE/DB	.00140 (0) (.387) (1.63) [-.136; .983] <.000853>
XD/UG ; ZD/DC ; PSI/DP	.121 (1.72) [-.124; .466] [.0100; 2.22] <.224>
YD/VG ; ZD/DC ; PHI/DA	-.144 (0) (-.0312) (.520) [-.235; .347] <.000281>
YD/VG ; ZD/DC ; THE/DB	.0696 (0) (.00403) (.386) [.0394; 2.81] <.000853>
YD/VG ; ZD/DC ; PSI/DP	.236 (.653) [-.271; .391] [.0275; 3.08] <.224>
XD/UG ; PHI/DA ; THE/DB ; PSI/DP	.685E-4 (.00778) (-5.32) <-.284E-5>
ZD/UG ; PHI/DA ; THE/DB ; PSI/DP	.0149 (0) (.00828) <.000123>
YD/VG ; PHI/DA ; THE/DB ; PSI/DP	.00115 (-.00797) (.310) <-.284E-5>
XD/WG ; PHI/DA ; THE/DB ; PSI/DP	.00316 (0) (.00817) <.258E-4>
ZD/WG ; PHI/DA ; THE/DB ; PSI/DP	.0459 (.00768) (-.00805) <-.284E-5>
XD/UG ; ZD/DC ; PHI/DA ; THE/DB	.000940 (0) (-.0771) (1.21) <.875E-4>
YD/VG ; ZD/DC ; PHI/DA ; THE/DB	.0244 (0) (0) (.126) <.00308>
YD/VG ; ZD/DC ; PHI/DA ; PSI/DP	.0707 (.395) [-.352; .310] <.00269>
XD/WG ; ZD/DC ; PHI/DA ; THE/DB	.0258 (0) (.0616) (.631) <.00100>
XD/UG ; ZD/DC ; PHI/DA ; THE/DB ; PSI/DP	-.000748 (-.00688) <.514E-5>
YD/VG ; ZD/DC ; PHI/DA ; THE/DB ; PSI/DP	-.0119 (0) <-.0119>
XD/WG ; ZD/DC ; PHI/DA ; THE/DB ; PSI/DP	-.0311 (.00832) <-.000259>

TABLE V-5 CONTINUED
UH-IH TRANSFER FUNCTION FACTORS

CASE I22 HOVER BAR ON

DENOMINATOR: (0) (-.428) (-.676) [-.569; .217] [-.201; .229] [.259; .903] [-.216; 1.95] <.00223>

CONTROL NUMERATORS:

PHI/DA .569 (0) (.0664) (.333) (.442) (.620) [.0778; .186] [.262; .928] <.000103>
THE/DB -.169 (0) (-.00803) (.333) (.433) (.679) [.272; .185] [.219; 1.89] <.162E-4>
PSI/DP -1.20 (-.388) [-.567; .173] [-.234; .199] [.264; .903] [.247; 1.99] <-.00177>

PHI/DB .157 (0) (-.0566) (.301) (.333) [-.0580; .513] [.953; .606] <.861E-4>
PHI/DP .339 (0) (-.0413) (.374) [-.177; .236] [.489; .519] [.257; .960] <-.723E-4>
PHI/DC -.0817 (0) (-.00495) (.505) [.790; .315] [-.656; .526] [.0941; 1.00] <-.562E-5>

THE/DA .134 (0) (-.00772) (.333) (.457) [-.144; .579] [.995; .581] <-.178E-4>
THE/DP -.00660 (0) (0) (.138) (-.484) (-.523) (-.927) (-7.75) [.806; .733] <.000892>
THE/DC .00491 (0) (-.0175) (-.412) (-.718) (4.59) [-.219; .194] [.350; 2.60] <.299E-4>

PSI/DA .0829 (.333) (.409) (1.31) [-.116; .194] [.267; .930] [-.700; 1.93] <.00180>
PSI/DB .00222 (.333) (-1.22) (-2.92) (2.95) (4.82) [.935; .326] [-.155; .622] <.00154>
PSI/DC .437 (-.473) [-.286; .117] [-.135; .266] [.279; .906] [.244; 1.95] <.000617>

XD/DB 1.06 (0) (.333) (-.421) (-.683) [-.271; .185] [.217; 1.89] [.0216; 2.27] <.0633>
YD/DA .885 (-.0631) (.333) (.451) (.590) [.0785; .186] [.262; .927] [.0103; 4.53] <.00303>
ZD/DC -9.79 (0) (-.592) [-.197; .191] [-.665; .196] [.256; .910] [.217; 1.95] <-.0256>

XD/DC -.00871 (0) (.451) (.903) (1.39) (-7.30) (-8.81) [.248; .196] [.189; 2.11] <-.0543>
YD/DP 1.63 (-.0526) (.368) [-.187; .245] [.402; .447] [.249; .943] [.0627; 2.98] <-.00299>
ZD/DB .247 (0) (.333) (-.828) (-1.62) [-.330; .198] [-.375; 1.16] [.217; 2.07] <-.0250>

PHI/DA ;THE/DB -.0962 (0) (-.00787) (-.0616) (.333) (.333) (.444) (.621) <.143E-5>
PHI/DA ;PSI/DP -.711 (-.00838) (.333) (.385) [-.0966; .188] [.262; .927] <-.232E-4>
THE/DB ;PSI/DP .00203 (-.0126) (.333) (.395) [-.267; .101] [.253; 1.92] <-.126E-4>

PHI/DB ;PSI/DP -.190 (-.00719) (.333) (.334) (.475) [-.0668; .505] <-.184E-4>
PHI/DP ;THE/DB -.0572 (0) (.333) (.381) [-.643; .0153] [.462; .548] <-.514E-6>
PHI/DC ;THE/DB .0138 (0) (.0113) (.333) (.525) (-.889) [.542; .214] <-.111E-5>

THE/DA ;PSI/DP -.167 (-.00563) (.333) (.333) (-.507) [-.106; .521] <.143E-4>
THE/DP ;PHI/DA -.00465 (0) (-.00474) (-.109) (.333) (.469) (.825) (1.90) <-.590E-6>
THE/DC ;PHI/DA .00301 (0) (.333) (.435) (.630) (8.73) [.718; .0243] <.142E-5>

PSI/DA ;THE/DB -.0140 (-.00787) (.333) (.333) (.418) (1.34) [-.708; 1.92] <.253E-4>
PSI/DB ;PHI/DA -.00813 (-.00696) (.189) (.333) (.333) [-.0634; 1.10] <.145E-5>
PSI/DC ;THE/DB -.0740 (-.00951) (.333) (.494) [-.180; .198] [.253; 1.89] <-.161E-4>

PSI/DC ;PHI/DA .256 (.0168) (.333) (-.488) [.118; .200] [.265; .926] <.239E-4>
XD/DB ;PHI/DA .604 (0) (.0616) (.333) (.333) (.430) (.626) [.0192; 2.27] <.00572>
XD/DB ;PSI/DP -1.27 (.333) (.386) [-.253; .0976] [-.251; 1.92] [.0214; 2.27] <-.0295>

YD/DA ;THE/DB -.150 (-.00787) (-.0596) (.333) (.333) (.452) (.591) [.0110; 4.53] <.427E-4>
YD/DA ;PSI/DP -1.20 (.333) (.383) [-.0981; .188] [.262; .927] [-.0114; 4.37] <-.0889>
ZD/DC ;PHI/DA -5.57 (0) (.130) (.333) (-.554) [-.00129; .103] [-.256; .934] <-.00123>

ZD/DC ;THE/DB 1.65 (0) (-.00361) (.333) (-.610) [-.267; .187] [.221; 1.88] <.000150>
ZD/DC ;PSI/DP 11.7 [.564; .150] [-.154; .170] [-.262; .910] [.247; 1.98] <.0248>
XD/DC ;PHI/DA -.00546 (0) (.0309) (.333) (.468) (.701) (3.66) [-.411; 5.86] <-.00232>

XD/DC ;THE/DB -.0508 (0) (.333) (.597) [-.270; .185] [.231; 1.89] <-.00124>
XD/DC ;PSI/DP .0119 (.405) (5.94) [-.283; .161] [.365; 1.96] [-.125; 4.23] <.0514>
YD/DP ;PHI/DA .630 (-.0896) (-.211) (.333) (.345) [-.0756; .182] [.263; .927] <-.392E-4>

YD/DP ;THE/DB -.276 (.333) (-.376) [-.845; .0176] [.371; .478] [.0620; 2.95] <-.213E-4>
ZD/DB ;PHI/DA .140 (0) (-.0623) (.333) (.333) (.738) (-1.54) [-.343; 1.33] <-.00194>
ZD/DB ;PSI/DP -.296 (.333) (-1.62) [-.253; .173] [.451; 1.26] [-.211; 2.02] <.0311>

PHI/DA ;THE/DB ;PSI/DP .120 (.00765) (-.00787) (.333) (.333) (.392) <-.315E-6>
PHI/DC ;THE/DB ;PSI/DP .00851 (.333) (.333) (2.16) [.844; .0132] <.357E-6>
THE/DC ;PHI/DA ;PSI/DP -.0284 (0) (-.0215) (.333) (.333) <-.680E-4>

TABLE V-5 CONTINUED
UH-IH TRANSFER FUNCTION FACTORS

CASE 122 HOVER BAR ON

CONTROL NUMERATORS CONCLUDED:

PSI/DC ; PHI/DA ; THE/DB - .0432 (-.00794) (.0161) (.333) (.333) (.510) <-.313E-6>

XD/DB ; PHI/DA ; PSI/DP - .754 (.00752) (.333) (.333) (.383) [-.0193; 2.27] <-.00124>
 YD/DA ; THE/DB ; PSI/DP .202 (-.00776) (.333) (.333) (.390) [-.0107; 4.37] <-.00130>
 ZD/DC ; PHI/DA ; THE/DB .941 (0) (.00283) (.0575) (.333) (.333) (.572) <-.972E-5>

ZD/DC ; THE/DB ; PSI/DP -1.98 (.00583) (.333) [.197; .130] [.253; 1.92] <-.000238>
 ZD/DC ; PHI/DA ; PSI/DP 6.95 (.00784) (.333) [.190; .137] [.258; .933] <.000299>
 XD/DC ; PHI/DA ; THE/DB -.0290 (0) (.0612) (.333) (.333) (.565) <-.000111>

XD/DC ; PHI/DA ; PSI/DP .00676 (.0137) (.333) (.403) (4.25) [-.490; 5.15] <.00139>
 XD/DC ; THE/DB ; PSI/DP .0528 (.333) [-.177; .109] [.258; 1.91] <.000761>
 YD/DP ; PHI/DA ; THE/DB -.107 (-.00799) (.0743) (-.211) (.333) (.333) (.359) <-.532E-6>

ZD/DB ; PHI/DA ; PSI/DP -.175 (.00828) (.333) (.333) (-1.51) [.347; 1.34] <.000440>

ZD/DC ; PHI/DA ; THE/DB ; PSI/DP -1.17 (0) (.0111) (.333) (.333) <-.00145>
 XD/DC ; PHI/DA ; THE/DB ; PSI/DP .0311 (.00833) (.333) (.333) <.287E-4>

GUST NUMERATORS:

PHI/UG -.00722 (0) (0) (0) (.0555) (.296) [.912; .628] [.174; .899] <-.379E-4>
 THE/UG -.00157 (0) (0) (.369) (.577) (.874) [.279; .269] [.489; 1.81] <-.693E-4>
 PSI/UG .00215 (0) (0) (-.568) [-.929; .315] [-.220; .921] [.405; 2.58] <-.000681>

PHI/VG .0113 (0) (0) (.395) [.113; .275] [.725; .458] [.316; .989] <.695E-4>
 THE/VG -.00167 (0) (0) (-.00779) (-.452) [-.951; .636] [-.115; 2.04] <.990E-5>
 PSI/VG -.0208 (0) (0) (.407) [.139; .200] [.275; .898] [.266; 2.04] <-.00114>

PHI/WG .00568 (0) (0) (.0350) (-.275) (.841) [-.919; .253] [.0295; .890] <-.234E-5>
 THE/WG .00406 (0) (0) (.0169) (.393) (.662) [-.262; .221] [.305; 1.91] <.316E-5>
 PSI/WG .00649 (0) (-.0649) (-.0743) [-.583; .445] [.243; .776] [.0847; 1.85] <-.128E-4>

PHI/PG .586 (0) (.0737) (.269) (.387) (.846) [-.143; .273] [.412; .925] <.000242>
 THE/PG -.230 (0) (.00235) (.298) (.442) (.690) [.525; .0605] [.0725; 1.85] <-.618E-6>
 PSI/PG .372 (.380) [.0287; .320] [.723; .344] [-.271; 1.09] [-.0112; 1.50] <.00459>

PHI/QG .880 (0) (.0758) (.340) (.511) (.539) [-.0859; .112] [.181; .917] <.659E-4>
 THE/QG .191 (0) (.328) (.437) (.693) [-.224; .291] [.491; 1.90] <.00580>
 PSI/QG .0696 (.307) (-.390) (1.78) (-2.21) (-2.59) [-.0522; .115] [.192; .936] <.000976>

PHI/RG -.147 (0) (-.0833) (.389) [-.0957; .279] [.392; .438] [.186; .936] <.625E-4>
 THE/RG -.0127 (0) (-.00687) (-.0555) (.454) (1.10) [-.924; .341] [.805; 1.73] <.846E-6>
 PSI/RG .686 (.401) [.543; .179] [-.198; .213] [.263; .906] [.244; 1.97] <.00126>

XD/UG .0104 (0) (.858) [.287; .272] [.968; .447] [.445; 1.80] [-.00716; 2.28] <.00223>
 ZD/UG .126 (0) (0) (.00863) (.794) [-.339; .206] [.272; .913] [.206; 1.96] <.000117>
 YD/VG .0472 (0) (.391) [.0884; .279] [.695; .409] [.296; .977] [.0493; 3.13] <.00223>

XD/WG -.0139 (0) (0) (.519) (.594) (7.12) [.289; .223] [.258; 2.00] <-.00605>
 ZD/WG .376 (0) (.737) [-.606; .218] [-.133; .235] [-.244; .901] [.219; 1.95] <.00223>

PHI/UG ; THE/DB .00123 (0) (0) (.0566) (.297) (.333) [.909; .622] <.268E-5>
 PHI/UG ; PSI/DP .00793 (0) (0) (.00695) (.333) (.534) [.165; .900] <.795E-5>
 THE/UG ; PHI/DA -.000877 (0) (0) (.0672) (.333) (.401) (.561) (.723) <-.319E-5>

THE/UG ; PSI/DP .00190 (0) (.333) (.722) [.257; .182] [.495; 1.90] <.550E-4>
 PSI/UG ; PHI/DA .00182 (0) (0) (-.00839) (.189) (.333) [.258; .941] <-.856E-6>
 PSI/UG ; THE/DB -.000360 (0) (.333) (-.625) [.932; .314] [.390; 2.54] <.478E-4>

PHI/VG ; THE/DB -.00190 (0) (0) (-.00803) (.333) (.407) [-.687; .493] <.504E-6>
 PHI/VG ; PSI/DP -.00653 (0) (.289) (.333) [.0232; .298] [.373; .991] <-.551E-4>
 THE/VG ; PHI/DA -.000980 (0) (0) (-.00772) (.333) (.455) [.982; .696] <.555E-6>

THE/VG ; PSI/DP .00187 (0) (0) (-.00546) (.333) (.615) [.0618; 1.96] <-.799E-5>
 PSI/VG ; PHI/DA -.0128 (0) (.333) (.407) [.119; .194] [.262; .925] <-.560E-4>
 PSI/VG ; THE/DB .00353 (0) (0) (-.00792) (.333) (.416) [.278; 1.97] <-.151E-4>

TABLE V-5 CONTINUED
UH-IH TRANSFER FUNCTION FACTORS

CASE I22 HOVER BAR ON

GUST NUMERATORS CONTINUED:

PHI/WG ; THE/DB	-.000995	(0)	(0)	(.0223)	(.103)	(.199)	(.333)	(.918)	<-.139E-6>
PHI/WG ; PSI/DP	-.00901	(0)	(.0229)	(.131)	(-.202)	(.333)	[.0591; .891]	<.144E-5>	
THE/WG ; PHI/DA	.00230	(0)	(0)	(.0123)	(.0519)	(.333)	(.423)	(.611)	<.127E-6>
THE/WG ; PSI/DP	-.00483	(0)	(.0175)	(.333)	[.223; .154]	[.361; 1.94]	<-.251E-5>		
PSI/WG ; PHI/DA	.00322	(0)	(.0295)	(.333)	[.265; .223]	[.255; .908]	<.129E-5>		
PSI/WG ; THE/DB	-.00111	(0)	(.0193)	(.333)	[.495; .337]	[.105; 1.68]	<-.227E-5>		
PHI/PG ; THE/DB	-.0970	(0)	(-.00863)	(.0749)	(.267)	(.333)	(.403)	(.794)	<.178E-5>
PHI/PG ; PSI/DP	-.829	(.00651)	(.333)	(.383)	[.147; .268]	[.407; .939]	<-.436E-4>		
THE/PG ; PHI/DA	-.132	(0)	(-.00719)	(.0732)	(.291)	(.333)	(.449)	(.629)	<.191E-5>
THE/PG ; PSI/DP	.278	(0)	(-.111)	(.112)	(.333)	(.396)	[.0866; 1.89]	<-.00162>	
PSI/PG ; PHI/DA	.163	(.0375)	(.333)	(.382)	[-.209; .150]	[.267; .949]	<.159E-4>		
PSI/PG ; THE/DB	-.0624	(-.00857)	(.333)	(.393)	[.671; .435]	[-.0228; 1.59]	<.337E-4>		
PHI/QG ; THE/DB	-.150	(0)	(-.00229)	(.0616)	(.333)	(.341)	(.461)	(.587)	<.654E-6>
PHI/QG ; PSI/DP	-1.08	(.0144)	(.333)	(.387)	[-.00920; .111]	[.179; .917]	<-.206E-4>		
THE/QG ; PHI/DA	.106	(0)	(.00162)	(.0616)	(.323)	(.333)	(.445)	(.623)	<.315E-6>
THE/QG ; PSI/DP	-.228	(0)	(.333)	(.386)	[.226; .210]	[.522; 1.96]	<-.00499>		
PSI/QG ; PHI/DA	-.0334	(-.0645)	(.120)	(-.253)	(.333)	(.371)	[.265; 1.00]	<-.814E-5>	
PSI/QG ; THE/DB	-.0122	(-.00210)	(.312)	(.333)	(.413)	(1.74)	(-2.00)	(-2.68)	<.102E-4>
PHI/RG ; THE/DB	.0250	(0)	(-.00818)	(-.0660)	(.333)	(.400)	[.284; .483]	<.420E-6>	
PHI/RG ; PSI/DP	-.0558	(.0263)	(.333)	(.951)	[.241; .166]	[.338; .818]	<-.863E-5>		
THE/RG ; PHI/DA	-.00684	(0)	(-.00763)	(-.112)	(.333)	(.456)	(.677)	(-.898)	<.538E-6>
THE/RG ; PSI/DP	.0198	(.00125)	(.333)	(-.419)	[.544; .221]	[.120; 1.75]	<-.518E-6>		
PSI/RG ; PHI/DA	.403	(.00475)	(.333)	(.400)	[.0940; .189]	[.263; .928]	<.781E-5>		
PSI/RG ; THE/DB	-.116	(-.00813)	(.333)	(.410)	[.216; .135]	[.248; 1.91]	<.857E-5>		
XD/UG ; PHI/DA	-.00590	(0)	(.0670)	(.333)	(.740)	[.952; .463]	[-.0357; 2.22]	<.000103>	
XD/UG ; THE/DB	-.960E-4	(0)	(.333)	(.833)	(-5.16)	[.280; .191]	[.151; 1.80]	<.162E-4>	
XD/UG ; PSI/DP	-.0125	(.415)	(.549)	[.266; .182]	[.459; 1.89]	[-.0136; 2.28]	<-.00177>		
ZD/UG ; PHI/DA	.0716	(0)	(0)	(.00556)	(.0618)	(.333)	(.733)	[.269; .946]	<.539E-5>
ZD/UG ; THE/DB	-.0209	(0)	(0)	(.333)	(.795)	[.340; .199]	[.203; 1.89]	<-.000777>	
ZD/UG ; PSI/DP	-.151	(0)	(.00586)	[.268; .179]	[.282; .918]	[.243; 1.98]	<-.928E-4>		
YD/VG ; PHI/DA	.0168	(0)	(.143)	(.333)	(.373)	[.0353; .180]	[.262; .923]	<.821E-5>	
YD/VG ; THE/DB	-.00794	(0)	(-.00803)	(.333)	(.404)	[.628; .441]	[.0577; 3.11]	<.162E-4>	
YD/VG ; PSI/DP	-.0225	(.266)	(.323)	[.00333; .291]	[.354; .983]	[.0409; 3.34]	<-.00177>		
XD/WG ; PHI/DA	.00716	(0)	(0)	(.0563)	(.333)	(-8.60)	[.991; .554]	<-.000354>	
XD/WG ; THE/DB	-.00449	(0)	(0)	(.333)	(.729)	[.270; .186]	[.223; 1.88]	<-.000134>	
XD/WG ; PSI/DP	.0184	(0)	(.405)	(6.04)	[.261; .154]	[.300; 2.08]	<.00462>		
ZD/WG ; PHI/DA	.214	(0)	(.0672)	(.333)	(.705)	[.209; .190]	[.246; .919]	<.000103>	
ZD/WG ; THE/DB	-.0645	(0)	(-.00824)	(.333)	(.745)	[.263; .186]	[.224; 1.88]	<.162E-4>	
ZD/WG ; PSI/DP	-.451	[.603; .170]	[-.178; .205]	[.244; .902]	[.249; 1.99]	<-.00177>			
XD/UG ; ZD/DC	-.101	(0)	(.209)	(.861)	[.0772; .293]	[.527; 1.81]	[.0259; 2.25]	<-.0256>	
YD/VG ; ZD/DC	-.413	(0)	[.198; .196]	[.726; .419]	[.293; .959]	[.0467; 3.17]	<-.0256>		
PHI/UG ; THE/DB ; PSI/DP	-.00136	(0)	(.00719)	(.333)	(.333)	(.528)	<-.573E-6>		
THE/UG ; PHI/DA ; PSI/DP	.00111	(0)	(.00838)	(.333)	(.333)	(.698)	<.721E-6>		
PSI/UG ; PHI/DA ; THE/DB	-.000307	(0)	(-.00696)	(.189)	(.333)	(.333)	<.450E-7>		
PHI/VG ; THE/DB ; PSI/DP	.00109	(0)	(-.0127)	(.256)	(.333)	(.333)	<-.394E-6>		
THE/VG ; PHI/DA ; PSI/DP	.00112	(0)	(-.00563)	(.333)	(.333)	(.638)	<-.447E-6>		
PSI/VG ; PHI/DA ; THE/DB	.00216	(0)	(-.00787)	(.333)	(.333)	(.416)	<-.788E-6>		
PHI/WG ; THE/DB ; PSI/DP	.00157	(0)	(.333)	(.333)	[.955; .0145]	<.364E-7>			
THE/WG ; PHI/DA ; PSI/DP	-.00284	(0)	(.00337)	(.0200)	(.333)	(.333)	<-.212E-7>		
PSI/WG ; PHI/DA ; THE/DB	-.000547	(0)	(-.00804)	(.0333)	(.333)	(.333)	<.163E-7>		

TABLE V-5 CONTINUED
UH-IH TRANSFER FUNCTION FACTORS

CASE I22 HOVER BAR ON

GUST NUMERATORS CONCLUDED:

PHI/PG ; THE/DB ; PSI/DP	.138 (.00664) (-.00807) (.333) (.333) (.394) <-.323E-6>
THE/PG ; PHI/DA ; PSI/DP	.166 (.00617) (-.00766) (.333) (.333) (.389) <-.340E-6>
PSI/PG ; PHI/DA ; THE/DB	-.0275 (-.00786) (.0204) (.333) (.333) (.396) <.194E-6>
PHI/QG ; THE/DB ; PSI/DP	.185 (-.00268) (.00865) (.333) (.333) (.391) <-.186E-6>
THE/QG ; PHI/DA ; PSI/DP	-.133 (.333) (.333) (.390) [.787; .00453] <-.118E-6>
PSI/QG ; PHI/DA ; THE/DB	.00554 (-.00767) (.0622) (.333) (.333) (.402) <-.118E-6>
PHI/RG ; THE/DB ; PSI/DP	.00925 (-.00499) (.0144) (.333) (.333) (.762) <-.562E-7>
THE/RG ; PHI/DA ; PSI/DP	.0118 (-.0980) (.333) (.333) [-.417; .0244] <-.767E-7>
PSI/RG ; PHI/DA ; THE/DB	-.0681 (.00416) (-.00787) (.333) (.333) (.409) <.101E-6>
XD/UG ; PHI/DA ; THE/DB	-.674E-4 (0) (.0617) (.333) (.333) (.761) (-4.07) <.143E-5>
XD/UG ; PHI/DA ; PSI/DP	-.00737 (.00838) (.333) (.412) (.547) [-.0375; 2.24] <-.232E-4>
XD/UG ; THE/DB ; PSI/DP	.991E-4 (.333) (-6.50) [-.0908; .135] [.238; 1.79] <-.126E-4>
ZD/UG ; PHI/DA ; THE/DB	-.0119 (0) (0) (.0623) (.333) (.333) (.733) <-.603E-4>
ZD/UG ; PHI/DA ; PSI/DP	-.0895 (0) (.00564) (.00806) (.333) [.270; .947] <-.122E-5>
ZD/UG ; THE/DB ; PSI/DP	.0250 (0) (.333) [.268; .178] [.245; 1.91] <.000967>
YD/VG ; PHI/DA ; THE/DB	-.00284 (0) (-.00789) (.103) (.333) (.333) (.394) <.101E-6>
YD/VG ; PHI/DA ; PSI/DP	-.00684 (.314) (.333) [.0414; .195] [.259; .922] <-.232E-4>
YD/VG ; THE/DB ; PSI/DP	.00377 (-.0127) (.222) (.322) (.333) [.0564; 3.33] <-.126E-4>
XD/WG ; PHI/DA ; THE/DB	-.00255 (0) (0) (.0616) (.333) (.333) (.689) <-.120E-4>
XD/WG ; PHI/DA ; PSI/DP	-.00888 (0) (.0125) (.333) (.403) (-8.54) <.000127>
XD/WG ; THE/DB ; PSI/DP	.00534 (0) (.333) [-.184; .107] [-.258; 1.92] <.749E-4>
ZD/WG ; PHI/DA ; THE/DB	-.0367 (0) (-.00805) (.0616) (.333) (.333) (.708) <.143E-5>
ZD/WG ; PHI/DA ; PSI/DP	-.267 (.00837) (.333) [.213; .192] [.245; .919] <-.232E-4>
ZD/WG ; THE/DB ; PSI/DP	.0775 (-.0136) (.333) [-.201; .0985] [.256; 1.93] <-.126E-4>
XD/UG ; ZD/DC ; PHI/DA	-.0571 (0) (.333) (.739) [.587; .136] [.0380; 2.17] <-.00123>
XD/UG ; ZD/DC ; THE/DB	.00140 (0) (.333) (1.34) [.467; .231] [.123; 2.11] <.000150>
XD/UG ; ZD/DC ; PSI/DP	.121 (.330) [-.262; .182] [.470; 1.92] [.0185; 2.25] <.0248>
YD/VG ; ZD/DC ; PHI/DA	-.144 (0) (-.0802) (.333) [-.638; .214] [-.251; .927] <.000152>
YD/VG ; ZD/DC ; THE/DB	.0696 (0) (.00360) (.333) [.699; .425] [.0551; 3.15] <.000150>
YD/VG ; ZD/DC ; PSI/DP	.236 (.282) [-.214; .193] [.348; .944] [.0381; 3.35] <.0248>
XD/UG ; PHI/DA ; THE/DB ; PSI/DP	.685E-4 (.00778) (.333) (.333) (-5.32) <-.315E-6>
ZD/UG ; PHI/DA ; THE/DB ; PSI/DP	.0149 (0) (.00828) (.333) (.333) <.137E-4>
YD/VG ; PHI/DA ; THE/DB ; PSI/DP	.00115 (-.00797) (.310) (.333) (.333) <-.315E-6>
XD/WG ; PHI/DA ; THE/DB ; PSI/DP	.00316 (0) (.00817) (.333) (.333) <.286E-5>
ZD/WG ; PHI/DA ; THE/DB ; PSI/DP	.0459 (.00768) (-.00805) (.333) (.333) <-.315E-6>
XD/UG ; ZD/DC ; PHI/DA ; THE/DB	.000940 (0) (-.0771) (.333) (.333) (1.21) <.972E-5>
YD/VG ; ZD/DC ; PHI/DA ; THE/DB	.0244 (0) (0) (.126) (.333) (.333) <.000342>
YD/VG ; ZD/DC ; PHI/DA ; PSI/DP	.0707 (.333) [.163; .121] [.253; .932] <.000299>
XD/WG ; ZD/DC ; PHI/DA ; THE/DB	.0258 (0) (.0616) (.333) (.333) (.631) <.000111>
XD/UG ; ZD/DC ; PHI/DA ; THE/DB ; PSI/DP	-.000748 (-.00688) (.333) (.333) <.571E-6>
YD/VG ; ZD/DC ; PHI/DA ; THE/DB ; PSI/DP	-.0119 (0) (.333) (.333) <.00132>
XD/WG ; ZD/DC ; PHI/DA ; THE/DB ; PSI/DP	-.0311 (.00832) (.333) (.333) <-.287E-4>

TABLE V-5 CONTINUED
UH-IH TRANSFER FUNCTION FACTORS

CASE 124 20KT BAR OFF

DENOMINATOR: (0) (.187) (.999) [-.203; .328] [.811; .661] [.204; .897] <.00708>

CONTROL NUMERATORS:

PHI/DA .571 (0) [-.352; .342] [.984; .560] [.430; .926] <.0180>
THE/DB -.173 (0) (.00520) (.170) (.526) (1.05) [-.224; .908] <-.699E-4>
PSI/DP -1.04 (1.00) [-.156; .295] [-.225; .419] [.815; .676] <-.00721>

PHI/DB .0280 (0) (.910) (5.21) [-.0948; .204] [.349; .918] <.00466>
PHI/DP .296 (0) (-.722) (.843) [-.205; .297] [.803; .686] <-.00751>
PHI/DC -.00992 (0) (.624) (-8.44) [-.320; .345] [.863; 1.14] <.00810>

THE/DA .130 (0) (.0126) (.214) (.564) [-.260; 1.05] <.000216>
THE/DP -.0244 (0) (.0121) (.0920) (.494) [-2.79] [.818; .779] <.227E-4>
THE/DC .0209 (0) (.0131) (.219) [-.132; .956] [.962; 1.28] <.892E-4>

PSI/DA .0831 (.514) [-.271; .336] [.992; .975] [-.578; 1.91] <.0168>
PSI/DB .0176 (1.00) [-.192; .245] [.547; 1.30] [-.907; 1.54] <.00423>
PSI/DC .354 (1.00) [-.278; .331] [-.203; .601] [.924; .742] <.00772>

XD/DB 1.07 (0) (.167) (.523) (1.05) [-.225; .911] [.0226; 2.28] <.427>
YD/DA .889 [-.350; .344] [.981; .559] [.407; .917] [.00563; 4.53] <.567>
ZD/DC -9.31 (0) (.0109) (-4.34) (-9.40) [-.125; .423] [.208; .891] <-.00588>

XD/DC -.0370 (0) (.222) [-.124; .922] [.957; 1.28] [.00992; 4.39] <-.222>
YD/DP 1.41 (-.772) (.837) [-.205; .298] [.802; .688] [.0744; 2.52] <-.244>
ZD/DB .811 (0) (.156) (-.399) (1.06) [-.207; .894] [.0534; 2.02] <-.174>

PHI/DA ; THE/DB -.0989 (0) (.00707) (.561) [-.442; .904] <-.000320>
PHI/DA ; PSI/DP -.616 (.0291) [-.296; .303] [.947; .553] <-.000503>
THE/DB ; PSI/DP .180 (.00459) (-.536) (1.02) [-.110; .358] <.577E-4>

PHI/DB ; PSI/DP -.0343 (.0272) (.960) (3.92) [-.107; .275] <-.000266>
PHI/DP ; THE/DB -.0506 (0) (.00456) (-.548) (-.599) (.782) <.592E-4>
PHI/DC ; THE/DB -.0171 (0) (.00701) [.911; 1.08] <-.000139>

THE/DA ; PSI/DP -.142 (.0125) (.566) [-.0333; .523] <-.000275>
THE/DP ; PHI/DA -.0142 (0) (.0125) (.561) [-1.50] (1.91) <.000287>
THE/DC ; PHI/DA .0120 (0) (.00877) (-.293) (.446) (1.54) <-.211E-4>

PSI/DA ; THE/DB -.0144 (.00704) (.568) (1.48) [-.581; 1.87] <-.000295>
PSI/DB ; PHI/DA .00774 (.0256) (.355) (-3.17) [-.0833; 1.21] <-.000325>
PSI/DC ; THE/DB -.0616 (.00696) [-.262; .578] [.999; .951] <-.000130>

PSI/DC ; PHI/DA .203 (.0403) [-.315; .335] [.969; .642] <.000377>
XD/DB ; PHI/DA .612 (0) (.559) [.440; .902] [.0227; 2.29] <1.45>
XD/DB ; PSI/DP -1.11 (.528) (1.02) [-.107; .358] [.0244; 2.29] <-.401>

YD/DA ; THE/DB -.154 (.00703) (.560) [.413; .894] [.00663; 4.53] <-.00997>
YD/DA ; PSI/DP -1.04 [-.297; .304] [.943; .554] [-.0124; 4.36] <-.559>
ZD/DC ; PHI/DA -5.31 (0) (.607) [-.404; .333] [.372; .928] <-.308>

ZD/DC ; THE/DB 1.59 (0) (.0132) (.127) (1.05) [.191; .894] <.00225>
ZD/DC ; PSI/DP 9.64 (.0509) (.972) [.621; .360] [-.208; .471] <.0137>
XD/DC ; PHI/DA -.0211 (0) (-.300) (.444) (1.62) [-.0375; 4.13] <.0776>

XD/DC ; THE/DB -.0160 (0) (.368) [-.364; .636] [.990; 1.15] <-.00318>
YD/DC ; PSI/DP .0430 (1.12) (3.42) [-.0466; .470] [.106; 2.82] <.289>
YD/DP ; PHI/DA .542 (1.04) (-1.10) [-.301; .298] [.895; .556] <-.0170>

YD/DP ; THE/DB -.243 (.00460) (.550) (-.660) (.774) [.0831; 2.49] <.00195>
ZD/DB ; PHI/DA .462 (0) (-.401) [.458; .912] [.0353; 1.99] <-.611>
ZD/DB ; PSI/DP -.840 (-.421) (1.02) [-.115; .349] [.0414; 2.04] <.182>

PHI/DA ; THE/DB ; PSI/DP .107 (.00835) (.0283) (.559) <.141E-4>
PHI/DC ; THE/DB ; PSI/DP .0168 (.0114) (.0223) (1.12) <.482E-5>
THE/DC ; PHI/DA ; PSI/DP -.00785 (.0130) (.0437) (1.22) <-.544E-5>

TABLE V-5 CONTINUED
UH-IH TRANSFER FUNCTION FACTORS

CASE 124 20KT BAR OFF

CONTROL NUMERATORS CONCLUDED:

PSI/DC ; PHI/DA ; THE/DB - .0353 (.00713) (.0393) (-.718) <-.710E-5>
 XD/DB ; PHI/DA ; PSI/DP - .660 (.0281) (.556) [.0244; 2.29] <-.0540>
 YD/DA ; THE/DB ; PSI/DP .180 (.00850) (.559) [-.0108; 4.36] <.0163>
 ZD/DC ; PHI/DA ; THE/DB .910 (0) (.00686) [.418; .873] <.00476>
 ZD/DC ; THE/DB ; PSI/DP -1.66 (.0123) (1.02) [-.145; .381] <-.00303>
 ZD/DC ; PHI/DA ; PSI/DP 5.73 (.0189) (.371) [-.0875; .286] <.00329>
 XD/DC ; PHI/DA ; THE/DB - .00916 (0) (-.103) (-.282) (1.20) <.000319>
 XD/DC ; PHI/DA ; PSI/DP .0255 (.0433) (1.22) [-.0179; 3.15] <.0134>
 XD/DC ; THE/DB ; PSI/DP .00654 (1.09) (1.53) [-.178; .616] <.00412>
 YD/DP ; PHI/DA ; THE/DB -.0936 (.00839) (.557) (.989) (-1.10) <.000477>
 ZD/DB ; PHI/DA ; PSI/DP -.499 (.0283) (-.380) [.0328; 2.01] <.0217>
 ZD/DC ; PHI/DA ; THE/DB ; PSI/DP -.988 (.0119) (.0277) <-.000327>
 XD/DC ; PHI/DA ; THE/DB ; PSI/DP .00398 (.0404) (1.30) <.000209>

GUST NUMERATORS:

PHI/UG -.00308 (0) (0) (0) (-.642) (1.06) [.561; .638] <.000849>
 THE/UG -.000982 (0) (0) (.184) [-.380; .928] [.980; 1.19] <-.000220>
 PSI/UG .00919 (0) (0) (.998) [-.364; .415] [-.660; .715] <.000806>
 PHI/VG .0108 (0) (0) (.595) [-.203; .315] [.819; .589] <.000220>
 THE/VG -.00245 (0) (0) (0) (.0265) (.425) [-.672; .494] <-.672E-5>
 PSI/VG -.0215 (0) (0) (1.00) [-.217; .329] [.780; .648] <-.000979>
 PHI/WG .00356 (0) (0) (.537) [-.384; .358] [.371; 1.18] <.000340>
 THE/WG .00108 (0) (0) (.0132) (-.209) (1.94) [-.105; .961] <.533E-5>
 PSI/WG .00683 (0) (.670) (.979) [-.298; .338] [-.207; .798] <.000325>
 PHI/PG .830 (0) [-.243; .316] [.922; .683] [.432; .942] <.0343>
 THE/PG -.222 (0) (.0254) (-.241) (.289) (.615) [-.355; .946] <.000216>
 PSI/PG .330 (.977) [-.224; .322] [.898; .762] [-.458; 1.28] <.0320>
 PHI/QG .806 (0) (.241) (.729) [-.606; .364] [.432; .920] <.0159>
 THE/QG .293 (0) (.0123) (.191) (.545) (1.66) [.216; .966] <.000578>
 PSI/QG -.0999 (.243) (1.03) (-1.24) [-.376; .353] [.895; 1.97] <.0150>
 PHI/RG -.162 (0) (.856) (-1.07) [-.220; .306] [.818; .732] <.00744>
 THE/RG .00631 (0) (0) (.0200) (.352) (-6.36) [.864; .969] <-.000265>
 PSI/RG .723 (1.00) [-.195; .308] [-.225; .466] [.833; .690] <.00708>
 XD/UG .0173 (0) (.184) [-.407; .906] [.979; 1.08] [-.120; 1.53] <.00708>
 ZD/UG .233 (0) (0) (.158) (.971) [.504; .505] [.201; .902] <.00742>
 YD/VG .0661 (0) (.597) [-.203; .315] [.818; .587] [.107; 2.29] <.00708>
 XD/WG -.00263 (0) (0) (.211) (2.19) [-.0948; .952] [.125; 3.44] <-.0131>
 ZD/WG .553 (0) (.177) [-.232; .357] [.942; .839] [.205; .898] <.00708>
 PHI/UG ; THE/DB .000560 (0) (0) (1.11) [.0134; .482] <.000145>
 PHI/UG ; PSI/DP .000463 (0) (0) (.0240) (-.455) (2.14) <-.108E-4>
 THE/UG ; PHI/DA -.000557 (0) (0) (.598) [-.419; 1.29] <-.000559>
 THE/UG ; PSI/DP .00124 (0) [-.126; .413] [.911; 1.03] <.000224>
 PSI/UG ; PHI/DA .00550 (0) (0) (.0365) [-.853; .393] <.311E-4>
 PSI/UG ; THE/DB -.00157 (0) (-.265) (1.06) [.480; .544] <.000131>
 PHI/VG ; THE/DB -.00179 (0) (0) (.00524) [.971; .481] <-.218E-5>
 PHI/VG ; PSI/DP -.00477 (0) [-.197; .299] [.866; .726] <-.000225>
 THE/VG ; PHI/DA -.00141 (0) (0) (.0124) (.532) (.728) <-.674E-5>
 THE/VG ; PSI/DP .00201 (0) (0) (.0202) [.949; .497] <.000E-5>
 PSI/VG ; PHI/DA -.0132 (0) [-.307; .350] [.979; .569] <-.000523>
 PSI/VG ; THE/DB .00377 (0) (0) (.00687) (.572) (.925) <.137E-4>

TABLE V-5 CONTINUED
UH-IH TRANSFER FUNCTION FACTORS

CASE I24 20KT BAR OFF

GUST NUMERATORS CONTINUED:

PHI/WG ; THE/DB	- .000647 (0) (0) (.00757) [.451; 1.18] <-.687E-5>
PHI/WG ; PSI/DP	- .00571 (0) (.0105) (.410) [-.364; .297] <-.217E-5>
THE/WG ; PHI/DA	.000612 (0) (0) (.0160) [.675; .567] <.314E-5>
THE/WG ; PSI/DP	- .000950 (0) (.0130) (2.42) [-.0500; .465] <-.647E-5>
PSI/WG ; PHI/DA	.00360 (0) (.0580) (.589) [-.309; .378] <.176E-4>
PSI/WG ; THE/DB	- .00120 (0) (.00751) (1.19) [-.277; .773] <-.639E-5>
PHI/PG ; THE/DB	- .138 (0) (.00688) (.565) [.441; .949] <-.000481>
PHI/PG ; PSI/DP	- .958 (.0275) [-.232; .301] [.898; .667] <-.00106>
THE/PG ; PHI/DA	- .128 (0) (.00784) (.560) [.425; .942] <-.000499>
THE/PG ; PSI/DP	.238 (.0198) (-.486) (.596) [.471; .487] <-.000323>
PSI/PG ; PHI/DA	.119 (.0183) (.320) (-.544) [.499; .809] <-.000249>
PSI/PG ; THE/DB	- .0532 (.00685) (.571) (1.35) [-.422; 1.26] <-.000445>
PHI/QG ; THE/DB	- .148 (0) (.00883) (.557) [.444; .860] <-.000537>
PHI/QG ; PSI/DP	- .806 (.0375) (.173) (.671) [-.488; .280] <-.000274>
THE/QG ; PHI/DA	.166 (0) (.0121) (.560) [.428; .934] <.000983>
THE/QG ; PSI/DP	- .306 (-.0122) (.552) (1.65) [-.0838; .433] <-.000637>
PSI/QG ; PHI/DA	- .124 (.0219) (.330) (-.611) [.457; .862] <.000406>
PSI/QG ; THE/DB	.0121 (.00878) (.565) (-1.31) (2.41) (2.60) <-.000493>
PHI/RG ; THE/DB	.0279 (0) (.00524) (-.939) [.998; .731] <-.735E-4>
PHI/RG ; PSI/DP	- .0462 (.0354) [-.256; .301] [.984; .733] <-.795E-4>
THE/RG ; PHI/DA	.00378 (0) (.0124) (.554) (-2.92) (3.00) <-.000227>
THE/RG ; PSI/DP	.0111 (.0129) (-.740) (.893) [.252; .491] <-.227E-4>
PSI/RG ; PHI/DA	.426 (.0263) [-.297; .296] [.941; .560] <.000308>
PSI/RG ; THE/DB	- .125 (.00524) (.591) (1.03) [-.168; .419] <-.699E-4>
XD/UG ; PHI/DA	.00986 (0) (.594) [.564; 1.25] [-.147; 1.41] <.0180>
XD/UG ; THE/DB	- .00194 (0) (.118) (.453) (1.06) [.222; .797] <-.699E-4>
XD/UG ; PSI/DP	- .0178 [-.124; .415] [.927; .999] [.0154; 1.54] <-.00721>
ZD/UG ; PHI/DA	.133 (0) (0) [-.298; .412] [.501; .912] <.0189>
ZD/UG ; THE/DB	- .0396 (0) (0) (.155) (1.05) [.246; .920] <-.00549>
ZD/UG ; PSI/DP	- .242 (0) (.903) [.559; .431] [-.159; .432] <-.00757>
YD/VG ; PHI/DA	.0282 (0) (.589) [-.271; .294] [.890; .463] <.000308>
YD/VG ; THE/DB	- .0113 (0) (.00524) [.971; .481] [.135; 2.26] <-.700E-4>
YD/VG ; PSI/DP	- .0381 [-.196; .299] [.872; .724] [.115; 2.01] <-.00721>
XD/WG ; PHI/DA	- .00150 (0) (0) [.673; .571] [-.00252; 3.60] <-.00636>
XD/WG ; THE/DB	- .000700 (0) (0) (.332) (1.24) [-.0610; .813] <-.000191>
XD/WG ; PSI/DP	.00281 (0) (2.98) [-.0518; .466] [.126; 2.96] <.0160>
ZD/WG ; PHI/DA	.316 (0) (.561) [-.347; .349] [.444; .913] <.0180>
ZD/WG ; THE/DB	- .0967 (0) (.00523) (.164) (1.04) [.231; .901] <-.699E-4>
ZD/WG ; PSI/DP	- .573 [-.0807; .331] [-.295; .407] [.935; .834] <-.00721>
XD/UG ; ZD/DC	- .152 (0) (.0184) (1.16) [.729; .986] [-.214; 1.36] <-.00588>
YD/VG ; ZD/DC	- .602 (0) (.0167) (.609) [.249; .424] [.108; 2.31] <-.00588>
PHI/UG ; THE/DB ; PSI/DP	- .000121 (0) (.0272) (2.50) <-.826E-5>
THE/UG ; PHI/DA ; PSI/DP	.000739 (0) (.0291) (.728) <.156E-4>
PSI/UG ; PHI/DA ; THE/DB	- .000946 (0) (.0256) (.417) <-.101E-4>
PHI/VG ; THE/DB ; PSI/DP	.000762 (0) (.00459) (.514) <.180E-5>
THE/VG ; PHI/DA ; PSI/DP	.00119 (0) (.0125) (.575) <.855E-5>
PSI/VG ; PHI/DA ; THE/DB	.00230 (0) (.00704) (.568) <.920E-5>
PHI/WG ; THE/DB ; PSI/DP	.00102 (0) (.0152) (.0165) <.256E-6>
THE/WG ; PHI/DA ; PSI/DP	- .002570 (0) (.0130) (.0497) <-.368E-6>
PSI/WG ; PHI/DA ; THE/DB	- .000632 (0) (.00643) (.0630) <-.256E-6>

TABLE V-5 CONTINUED
UH-IH TRANSFER FUNCTION FACTORS

CASE 124 20KT BAR OFF

GUST NUMERATORS CONCLUDED:

PHI/PG ; THE/DB ; PSI/DP	.158 (.00833) (.0275) (.564) <.204E-4>
THE/PG ; PHI/DA ; PSI/DP	.141 (.00840) (.0272) (.557) <.170E-4>
PSI/PG ; PHI/DA ; THE/DB	-.0189 (.00845) (.0493) (.680) <-.457E-5>
PHI/QG ; THE/DB ; PSI/DP	.150 (.0106) (.0292) (.556) <.257E-4>
THE/QG ; PHI/DA ; PSI/DP	-.183 (.0122) (.0275) (.558) <-.340E-4>
PSI/QG ; PHI/DA ; THE/DB	.0192 (.0167) (.0570) (.576) <.105E-4>
PHI/RG ; THE/DB ; PSI/DP	.00765 (.00712) (.0328) (.823) <.147E-5>
THE/RG ; PHI/DA ; PSI/DP	.00656 (.0122) (.0461) (.392) <.144E-5>
PSI/RG ; PHI/DA ; THE/DB	-.0739 (.00864) (.0261) (.575) <-.959E-5>
XD/UG ; PHI/DA ; THE/DB	-.00111 (0) (.510) [.454;.752] <-.000320>
XD/UG ; PHI/DA ; PSI/DP	-.0106 (.0291) (.705) [.0328;1.52] <-.000503>
XD/UG ; THE/DB ; PSI/DP	.00175 (.330) (1.05) [-.0360;.309] <.577E-4>
ZD/UG ; PHI/DA ; THE/DB	-.0226 (0) (0) [.473;.224] <-.0193>
ZD/UG ; PHI/DA ; PSI/DP	-.144 (0) (.0289) [.407;.356] <-.000528>
ZD/UG ; THE/DB ; PSI/DP	.0410 (0) (1.01) [-.139;.371] <.00571>
YD/VG ; PHI/DA ; THE/DB	-.00486 (0) (.00865) [.991;.478] <-.959E-5>
YD/VG ; PHI/DA ; PSI/DP	-.0179 [-.302;.298] [.907;.563] <-.000503>
YD/VG ; THE/DB ; PSI/DP	.00646 (.00459) (.512) [-.183;1.95] <.577E-4>
XD/WG ; PHI/DA ; THE/DB	-.000395 (0) (0) [.554;.597] <-.000141>
XD/WG ; PHI/DA ; PSI/DP	.00167 (0) (.0491) [-.0132;3.31] <.000900>
XD/WG ; THE/DB ; PSI/DP	.000530 (0) (1.27) [-.194;.587] <.000232>
ZD/WG ; PHI/DA ; THE/DB	-.0552 (0) (.00708) [.453;.905] <-.000320>
ZD/WG ; PHI/DA ; PSI/DP	-.341 (.0288) (.508) [-.302;.317] <-.000503>
ZD/WG ; THE/DB ; PSI/DP	.100 (.00463) (1.01) [-.124;.352] <.577E-4>
XD/UG ; ZD/DC ; PHI/DA	-.0869 (0) [-.359;1.28] [.624;1.47] <-.308>
XD/UG ; ZD/DC ; THE/DB	.0215 (0) (.211) (1.04) [.114;.689] <.00225>
XD/UG ; ZD/DC ; PSI/DP	.155 (.605) [-.109;.280] [.181;1.36] <.0137>
YD/VG ; ZD/DC ; PHI/DA	-.255 (0) (-.0174) (.620) [.0953;.367] <.000372>
YD/VG ; ZD/DC ; THE/DB	.103 (0) (.0127) (.333) [-.134;2.27] <.00225>
YD/VG ; ZD/DC ; PSI/DP	.364 (.0502) [-.659;.419] [-.110;2.06] <.0137>
XD/UG ; PHI/DA ; THE/DB ; PSI/DP	.00104 (.0277) (.490) <.141E-4>
ZD/UG ; PHI/DA ; THE/DB ; PSI/DP	.0244 (0) (.0283) <.000688>
YD/VG ; PHI/DA ; THE/DB ; PSI/DP	.00308 (.00839) (.547) <.141E-4>
XD/WG ; PHI/DA ; THE/DB ; PSI/DP	.000321 (0) (.0444) <.142E-4>
ZD/WG ; PHI/DA ; THE/DB ; PSI/DP	.0596 (.00838) (.0283) <.141E-4>
XD/UG ; ZD/DC ; PHI/DA ; THE/DB	.0123 (0) [.499;.622] <.00476>
YD/VG ; ZD/DC ; PHI/DA ; THE/DB	.0439 (0) (.0134) (.353) <.000208>
YD/VG ; ZD/DC ; PHI/DA ; PSI/DP	.168 (-.257) [-.0777;.276] <.00329>
XD/WG ; ZD/DC ; PHI/DA ; THE/DB	.00875 (0) (-.0640) (.570) <-.000319>
XD/UG ; ZD/DC ; PHI/DA ; THE/DB ; PSI/DP	-.0105 (.0310) <-.000327>
YD/VG ; ZD/DC ; PHI/DA ; THE/DB ; PSI/DP	-.0286 (.0114) <-.000327>
XD/WG ; ZD/DC ; PHI/DA ; THE/DB ; PSI/DP	-.00519 (.0402) <-.000209>

TABLE V-5 CONTINUED
UH-IH TRANSFER FUNCTION FACTORS

CASE 124 20KT BAR ON

DENOMINATOR: (0) (.0401) (.554) [.150; .161][.484; .855][.314; 1.02][.269; 1.95]<.00165>

CONTROL NUMERATORS:

PHI/DA .571 (0) (.333) (.552) [.162; .160][.436; .848][.319; 1.02]<.00199>
 THE/DB -.173 (0) (.00609) (.0343) (.333) (.562) [.477; .935][.265; 1.89]<-.211E-4>
 PSI/DP -1.04 (.550) [-.126; .140][.536; .140][.320; .955][.303; 2.00]<-.000802>

PHI/DB .0280 (0) (.330) (.333) (.833) (5.23) [-.00876; .218][.369; .915]<.000533>
 PHI/DP .296 (0) (-.539) (.579) [.144; .176][.876; .507][.378; 1.04]<-.000805>
 PHI/DC -.00992 (0) (.389) (-8.20) [.155; .161][.789; .942][.396; 1.10]<.000877>

THE/DA .130 (0) (.0105) (.333) (.565) [.812; .342][.267; 1.02]<.314E-4>
 THE/DP -.0244 (0) (.413) (.563) (1.27) (-2.16) [.925; .0167][-.103; 1.77]<.135E-4>
 THE/DC .0209 (0) (.0107) (1.28) [.0428; .206][.910; .475][.221; 2.08]<.120E-4>

PSI/DA .0831 (.333) (.573) (1.29) [.194; .157][.326; 1.01][-.574; 1.91]<.00187>
 PSI/DB .0176 (-.145) (.171) (.333) (.366) (-1.92) [-.417; .964][.491; 2.23]<.000470>
 PSI/DC .354 (.686) [.167; .167][.369; .194][.327; .943][.286; 1.95]<.000858>

XD/DB 1.07 (0) (.0334) (.333) (.560) [.476; .931][.267; 1.89][.0219; 2.28]<.108>
 YD/DA .889 (.333) (.550) [-.166; .161][.407; .841][.317; 1.02][.00558; 4.53]<.0630>
 ZD/DC -9.31 (0) (.0137) [.179; .165][.518; .789][.275; 1.07][.271; 1.95]<-.00925>

XD/DC -.0370 (0) (1.32) [.0420; .206][.924; .494][.224; 1.98][.00846; 4.25]<-.0357>
 YD/DP 1.41 (.304) (.491) (.694) (-.699) [.0829; .171][.352; 1.02][.0935; 2.95]<-.0271>
 ZD/DB .811 (0) (.0330) (.333) (-.401) [-.500; .952][.177; 1.91][.122; 1.95]<-.0449>

PHI/DA ; THE/DB -.0989 (0) (.00707) (.333) (.333) (.561) [.442; .904]<-.356E-4>
 PHI/DA ; PSI/DP -.616 (.0291) (.333) (.546) [.160; .134][.312; .979]<-.559E-4>
 THE/DB ; PSI/DP .180 (.00456) (.333) (.561) [.306; .105][.304; 1.95]<.642E-5>

PHI/DB ; PSI/DP -.0343 (.0272) (.333) (.335) (.964) (3.91) [-.104; .274]<-.295E-4>
 PHI/DP ; THE/DB -.0506 (0) (.00438) (.333) (-.454) (.566) [.852; .559]<.594E-5>
 PHI/DC ; THE/DB -.0168 (0) (.00701) (.333) (.391) [.829; .991]<-.151E-4>

THE/DA ; PSI/DP -.142 (.0125) (.333) (.333) (.566) [.0333; .523]<-.305E-4>
 THE/DP ; PHI/DA -.0142 (0) (.0125) (.333) (.407) (.563) (-1.36) (1.70) <.316E-4>
 THE/DC ; PHI/DA .0120 (0) (.00890) (-.212) (.333) (1.42) [.905; .450]<-.216E-5>

PSI/DA ; THE/DB -.0144 (.00704) (.333) (.333) (.568) (1.48) [-.581; 1.87]<-.328E-4>
 PSI/DB ; PHI/DA .00774 (.0256) (.333) (.333) (.355) (-3.17) [-.0833; 1.21]<-.361E-4>
 PSI/DC ; THE/DB -.0616 (.00696) (.333) (.702) [.344; .201][.289; 1.88]<-.144E-4>

PSI/DC ; PHI/DA .203 (.0403) (.333) (.698) [.176; .153][.316; .973]<.419E-4>
 XD/DB ; PHI/DA .612 (0) (.333) (.333) (.559) [.440; .902][.0227; 2.29]<.161>
 XD/DB ; PSI/DP -1.11 (.333) (.558) [.291; .104][.304; 1.95][.0249; 2.29]<-.0446>

YD/DA ; THE/DB -.154 (.00703) (.333) (.333) (.560) [.413; .894][.00663; 4.53]<-.00111>
 YD/DA ; PSI/DP -1.04 (.333) (.545) [.162; .134][.311; .979][-.0125; 4.36]<-.0621>
 ZD/DC ; PHI/DA -5.31 (0) (.333) [.0980; .168][.474; .769][.281; 1.07]<-.0337>

ZD/DC ; THE/DB 1.59 (0) (.0101) (.0286) (.333) [.455; .906][.266; 1.88]<.000446>
 ZD/DC ; PSI/DP 9.64 [.677; .0412][.235; .158][.311; .971][.302; 2.00]<.00152>
 XD/DC ; PHI/DA -.0211 (0) (-.218) (.333) (1.52) [.916; .467][.0327; 3.93]<.00783>

XD/DC ; THE/DB -.0160 (0) (.292) (.333) (1.18) [-.0186; .225][.280; 1.88]<-.000332>
 XD/DC ; PSI/DP .0430 (.365) (1.33) [-.368; .215][.805; 2.24][.0572; 2.57]<.0321>
 YD/DP ; PHI/DA .542 (.333) (.537) (1.00) (-1.10) [.141; .135][.309; .983]<-.00189>

YD/DP ; THE/DB -.243 (.00459) (.304) (.333) (.537) (-.644) (-.648) [.0967; 2.93]<.000217>
 ZD/DB ; PHI/DA .462 (0) (.333) (.333) (-.401) [.458; .912][.0353; 1.99]<-.0679>
 ZD/DB ; PSI/DP -.840 (.333) (-.392) [-.292; .110][.279; 1.93][.0666; 2.02]<.0202>

PHI/DA ; THE/DB ; PSI/DP .107 (.00835) (.0283) (.333) (.333) (.559) <.157E-5>
 PHI/DC ; THE/DB ; PSI/DP .0168 (.0114) (.0223) (.333) (.333) (1.12) <.535E-6>
 THE/DC ; PHI/DA ; PSI/DP -.00785 (.0130) (.0437) (.333) (.333) (1.22) <-.604E-6>

TABLE V-5 CONTINUED
UH-IH TRANSFER FUNCTION FACTORS

CASE 124 20KT BAR ON

CONTROL NUMERATORS CONCLUDED:

PSI/DC ; PHI/DA ; THE/DB -.0353 (.00713) (.0393) (.333) (.333) (.718) <-.789E-6>
 XD/DB ; PHI/DA ; PSI/DP -.660 (.0281) (.333) (.333) (.556) [.0244; 2.29] <-.00600>
 YD/DA ; THE/DB ; PSI/DP .180 (.00850) (.333) (.333) (.559) [-.0108; 4.36] <.00181>
 ZD/DC ; PHI/DA ; THE/DB .910 (0) (.00686) (.333) (.333) [.418; .873] <.000529>
 ZD/DC ; THE/DB ; PSI/DP -1.66 (.0123) (.333) [-.278; .114] [.303; 1.94] <-.000336>
 ZD/DC ; PHI/DA ; PSI/DP 5.73 (.0190) (.333) [.318; .102] [-.298; .989] <.000365>
 XD/DC ; PHI/DA ; THE/DB -.00916 (0) (-.103) (-.282) (.333) (.333) (1.20) <.355E-4>
 XD/DC ; PHI/DA ; PSI/DP .0255 (.0432) (.333) (.364) (1.21) [-.0223; 3.03] <.00148>
 XD/DC ; THE/DB ; PSI/DP .00654 (.333) (1.32) [.391; .206] [.322; 1.94] <.000458>
 YD/DP ; PHI/DA ; THE/DB -.0936 (.00839) (.333) (.333) (.557) (.989) (-1.10) <.530E-4>
 ZD/DB ; PHI/DA ; PSI/DP -.499 (.0283) (.333) (.333) (-.380) [-.0328; 2.01] <.00241>
 ZD/DC ; PHI/DA ; THE/DB ; PSI/DP -.988 (.0119) (.0277) (.333) (.333) <-.363E-4>
 XD/DC ; PHI/DA ; THE/DB ; PSI/DP .00398 (.0404) (.333) (.333) (1.30) <.232E-4>

GUST NUMERATORS:

PHI/UG -.00308 (0) (0) (0) (.304) (.937) [-.209; .413] [.360; 1.01] <-.000153>
 THE/UG -.000982 (0) (0) (.0403) (.342) (.624) [-.276; 1.29] [.568; 1.90] <-.513E-4>
 PSI/UG .00919 (0) (0) (-.0641) (-.129) (-.430) [-.294; .978] [.307; 2.02] <-.000127>
 PHI/VG .0108 (0) (0) (.529) [-.150; .169] [.658; .538] [.389; 1.04] <.514E-4>
 THE/VG -.00245 (0) (0) (0) (.0107) (-.577) [.854; .564] [.0601; 1.92] <-.179E-4>
 PSI/VG -.0215 (0) (0) (.563) [-.198; .160] [.335; .940] [.314; 2.04] <-.00114>
 PHI/WG .00356 (0) (0) (.368) [-.161; .157] [.484; .944] [.207; 1.13] <.367E-4>
 THE/WG .00108 (0) (0) (.0115) (.158) (.207) [.729; .775] [.402; 1.89] <.874E-6>
 PSI/WG .00683 (0) [.225; .146] [-.508; .293] [.317; .908] [.226; 1.87] <.361E-4>
 PHI/PG .830 (0) (.341) (.534) [-.146; .169] [.488; .936] [.373; 1.00] <.00381>
 THE/PG -.222 (0) (-.00730) (-.0158) (-.338) (-.561) [-.441; .920] [.0833; 1.86] <.142E-4>
 PSI/PG .330 (.468) [-.0999; .206] [-.751; .400] [-.416; 1.23] [-.147; 1.50] <.00355>
 PHI/QG .806 (0) (.325) (.575) [-.196; .140] [.324; .803] [.269; .956] <.00173>
 THE/QG .293 (0) (.0116) (.0518) (.337) (.560) [.461; 1.01] [.429; 1.87] <.000118>
 PSI/QG -.0999 (.272) (-.513) (-.867) [-.268; .111] [-.199; 1.05] [.559; 3.19] <.00167>
 PHI/RG -.162 (0) (.507) (-.882) [-.144; .173] [.905; .584] [.376; 1.05] <.000807>
 THE/RG .00631 (0) (.413) (.541) (1.63) (-5.83) [.851; .0146] [-.128; 1.68] <-.804E-5>
 PSI/RG .723 (.561) [-.138; .152] [-.545; .152] [-.318; .958] [.300; 1.99] <.000786>
 XD/UG .0173 (0) (-.0403) (.322) (.597) [-.519; 1.39] [.0894; 1.45] [.192; 1.75] <.00165>
 ZD/UG .233 (0) (0) [.968; .0459] [.522; .975] [.270; .988] [.263; 1.95] <.00173>
 YD/VG .0661 (0) (.515) [-.117; .169] [-.702; .458] [.358; 1.02] [.118; 2.79] <.00165>
 XD/WG -.00263 (0) (0) (.138) (.253) [-.741; .789] [.380; 2.08] [-.157; 3.10] <-.00238>
 ZD/WG .553 (0) (.0393) [-.170; .162] [-.488; .882] [-.312; .987] [.271; 1.95] <.00165>
 PHI/UG ; THE/DB .000560 (0) (0) (.306) (.333) (.951) [-.184; .552] <.166E-4>
 PHI/UG ; PSI/DP .000463 (0) (0) (.0276) (.333) (2.22) [-.0878; 1.15] <.124E-4>
 THE/UG ; PHI/DA -.000557 (0) (0) (.333) (.342) (.638) [-.420; 1.24] <-.618E-4>
 THE/UG ; PSI/DP .00124 (0) (.333) (-.689) [-.266; .147] [.332; 2.01] <.249E-4>
 PSI/UG ; PHI/DA .00550 (0) (0) (.0268) (.333) (.412) [-.302; .996] <.201E-4>
 PSI/UG ; THE/DB -.00157 (0) (-.113) (-.146) (.333) (.435) [-.301; 1.97] <.146E-4>
 PHI/VG ; THE/DB -.00179 (0) (0) (.00626) (.333) (.545) [-.636; .567] <-.658E-6>
 PHI/VG ; PSI/DP -.00477 (0) (.333) (.469) [-.103; .174] [-.460; 1.05] <-.250E-4>
 THE/VG ; PHI/DA -.00141 (0) (0) (-.0104) (.333) (-.583) [-.865; .584] <-.977E-6>
 THE/VG ; PSI/DP .00201 (0) (0) (.0128) (.333) (.573) [-.185; 1.92] <.180E-4>
 PSI/VG ; PHI/DA -.0132 (0) (.333) (.562) [-.200; .159] [-.315; .966] <-.582E-4>
 PSI/VG ; THE/DB .00377 (0) (0) (.00703) (.333) (-.568) [-.318; 1.98] <.197E-4>

TABLE V-5 CONTINUED
UH-IH TRANSFER FUNCTION FACTORS

CASE 124 20KT BAR ON

GUST NUMERATORS CONTINUED:

PHI/WG ; THE/DB	- .000647 (0) (0) (.00759) (.333) (.369) [.463; 1.12] <-.751E-6>
PHI/WG ; PSI/DP	- .00571 (0) (.0105) (.333) [.231; .115] [.248; .956] <-.242E-6>
THE/WG ; PHI/DA	.000612 (0) (0) (.0156) (.254) (.333) [.638; .663] <.356E-6>
THE/WG ; PSI/DP	- .000950 (0) (.0130) (.333) [.373; .208] [.637; 2.00] <-.719E-6>
PSI/WG ; PHI/DA	.00360 (0) (.0585) (.333) [.241; .174] [.316; .956] <.195E-5>
PSI/WG ; THE/DB	- .00120 (0) (.00751) (.333) [.504; .273] [.229; 1.78] <-.710E-6>
PHI/PG ; THE/DB	- .138 (0) (.00688) (.333) (.341) (.564) [.442; .937] <-.533E-4>
PHI/PG ; PSI/DP	- .958 (.0275) (.333) (.529) [.137; .157] [.404; 1.01] <-.000118>
THE/PG ; PHI/DA	- .128 (0) (.00784) (.333) (.338) (.559) [.426; .935] <-.553E-4>
THE/PG ; PSI/DP	.238 (.0196) (.101) (-.116) (.333) (.559) [.0951; 1.88] <-.359E-4>
PSI/PG ; PHI/DA	.119 (.0182) (.183) (.333) (-.342) (.496) [.262; 1.11] <-.277E-4>
PSI/PG ; THE/DB	- .0532 (.00685) (.333) (.606) [.912; .525] [-.119; 1.56] <-.495E-4>
PHI/QG ; THE/DB	- .148 (0) (.00886) (.325) (.333) (.558) [.442; .872] <-.602E-4>
PHI/QG ; PSI/DP	- .806 (.0362) (.333) (.574) [.202; .0792] [.160; .933] <-.304E-4>
THE/QG ; PHI/DA	.166 (0) (.0121) (.333) (.337) (.560) [.429; .928] <.000109>
THE/QG ; PSI/DP	- .306 (.0122) (.333) (.559) [.301; .161] [.455; 1.98] <-.708E-4>
PSI/QG ; PHI/DA	- .124 (.0218) (.201) (.333) (-.402) (.483) [.247; 1.13] <.452E-4>
PSI/QG ; THE/DB	.0121 (.00880) (.266) (.333) (.572) (-.784) [.633; 3.59] <-.548E-4>
PHI/RG ; THE/DB	.0279 (0) (.00515) (.333) (.496) (-.784) [.987; .644] <-.774E-5>
PHI/RG ; PSI/DP	- .0462 (.0353) (.333) (.804) [.154; .146] [.397; .972] <-.883E-5>
THE/RG ; PHI/DA	.00378 (0) (.0124) (.333) (.408) (.538) (-2.69) (2.71) <-.250E-4>
THE/RG ; PSI/DP	.0111 (.0129) (.197) (-.202) (.333) (.419) [.0896; 1.78] <-.252E-5>
PSI/RG ; PHI/DA	.426 (.0263) (.333) (.559) [.156; .130] [.312; .981] <.342E-4>
PSI/RG ; THE/DB	- .125 (.00522) (.333) (.574) [.288; .129] [.301; 1.93] <-.777E-5>
XD/UG ; PHI/DA	- .00986 (0) (.321) (.333) (.607) [.474; 1.18] [-.0442; 1.49] <.00199>
XD/UG ; THE/DB	- .00194 (0) (.0300) (.333) (.512) [.482; .768] [.272; 1.90] <-.211E-4>
XD/UG ; PSI/DP	- .0178 (.305) (.624) [.246; .146] [.0634; 1.69] [.316; 1.97] <-.000802>
ZD/UG ; PHI/DA	.133 (0) (0) (.0521) (.333) [.478; .962] [.265; .987] <.00209>
ZD/UG ; THE/DB	- .0396 (0) (0) (.0330) (.333) [.512; .954] [.260; 1.89] <-.00142>
ZD/UG ; PSI/DP	- .242 (0) (.0587) [.216; .122] [.295; .999] [.303; 2.00] <-.000841>
YD/VG ; PHI/DA	.0282 (0) (.333) [.202; .112] [.979; .481] [.307; .979] <.262E-4>
YD/VG ; THE/DB	- .0113 (0) (.00625) (.333) (.536) [.658; .468] [.131; 2.76] <-.211E-4>
YD/VG ; PSI/DP	- .0381 (.202) (.507) [.0642; .167] [.402; 1.03] [.135; 2.63] <-.000802>
XD/WG ; PHI/DA	- .00150 (0) (0) (.281) (.333) [.645; .667] [-.00851; 3.43] <-.000739>
XD/WG ; THE/DP	- .000700 (0) (0) (.0734) (.333) [.590; .676] [.253; 1.85] <-.269E-4>
XD/WG ; PSI/DP	.00281 (0) (.366) [.374; .208] [.714; 2.38] [.0786; 2.65] <.00177>
ZD/WG ; PHI/DA	.316 (0) (.333) [.178; .160] [.454; .879] [.311; .979] <.00199>
ZD/WG ; THE/DB	- .0967 (0) (.00612) (.0342) (.333) [.486; .938] [.267; 1.89] <-.211E-4>
ZD/WG ; PSI/DP	- .573 [.555; .136] [-.106; .146] [.312; .941] [.305; 2.01] <-.000802>
XD/UG ; ZD/DC	- .152 (0) (.0144) (.359) [-.188; 1.15] [.637; 1.60] [-.192; 1.86] <-.00925>
YD/VG ; ZD/DC	- .602 (0) [.239; .0941] [.687; .462] [.326; 1.02] [.118; 2.81] <-.00925>
PHI/UG ; THE/DB ; PSI/DP	- .000121 (0) (.0272) (.333) (.333) (2.50) <-.918E-6>
THE/UG ; PHI/DA ; PSI/DP	.000739 (0) (.0291) (.333) (.333) (.728) <.174E-5>
PSI/UG ; PHI/DA ; THE/DB	- .000946 (0) (.0256) (.333) (.333) (.417) <-.112E-5>
PHI/VG ; THE/DB ; PSI/DP	.000762 (0) (.00459) (.333) (.333) (.514) <.200E-6>
THE/VG ; PHI/DA ; PSI/DP	.00119 (0) (.0125) (.333) (.333) (.575) <.950E-6>
PSI/VG ; PHI/DA ; THE/DB	.00230 (0) (.00704) (.333) (.333) (.568) <.102E-5>
PHI/WG ; THE/DB ; PSI/DP	.00102 (0) (.0152) (.0165) (.333) (.333) <.284E-7>
THE/WG ; PHI/DA ; PSI/DP	- .000570 (0) (.0137) (.0497) (.333) (.333) <-.409E-7>
PSI/WG ; PHI/DA ; THE/DB	- .000632 (0) (.00643) (.0630) (.333) (.333) <-.284E-7>

TABLE V-5 CONTINUED
UH-IH TRANSFER FUNCTION FACTORS

CASE 124 20KT BAR ON

GUST NUMERATORS CONCLUDED:

PHI/PG ; THE/DB ; PSI/DP	.158 (.00833) (.0275) (.333) (.333) (.564) <-.227E-5>
THE/PG ; PHI/DA ; PSI/DP	-.141 (.00840) (.0272) (.333) (.333) (.557) <-.199E-5>
PSI/PG ; PHI/DA ; THE/DB	-.0189 (.00845) (.0493) (.333) (.333) (.580) <-.508E-6>
PHI/QG ; THE/DB ; PSI/DP	.150 (.0106) (.0292) (.333) (.333) (.556) <-.285E-5>
THE/QG ; PHI/DA ; PSI/DP	-.183 (.0122) (.0275) (.333) (.333) (.558) <-.378E-5>
PSI/QG ; PHI/DA ; THE/DB	.0192 (.0167) (.0570) (.333) (.333) (.576) <-.117E-5>
PHI/RG ; THE/DB ; PSI/DP	.00765 (.00712) (.0328) (.333) (.333) (.823) <-.164E-6>
THE/RG ; PHI/DA ; PSI/DP	.00656 (.0122) (.0461) (.333) (.333) (.392) <-.160E-6>
PSI/RG ; PHI/DA ; THE/DB	-.0739 (.00864) (.0261) (.333) (.333) (.575) <-.107E-5>
XD/UG ; PHI/DA ; THE/DB	-.00111 (0) (.333) (.333) (.510) [.454; .752] <-.356E-4>
XD/UG ; PHI/DA ; PSI/DP	-.0106 (.0291) (.304) (.333) (.646) [.0565; 1.67] <-.559E-4>
XD/UG ; THE/DB ; PSI/DP	.00175 (.333) (.496) [.354; .0765] [.304; 1.94] <-.642E-5>
ZD/UG ; PHI/DA ; THE/DB	-.0226 (0) (0) (.333) (.333) [.473; .924] <-.00215>
ZD/UG ; PHI/DA ; PSI/DP	-.144 (0) (.0307) (.0383) (.333) [.286; 1.02] <-.586E-4>
ZD/UG ; THE/DB ; PSI/DP	.0410 (0) (.333) [.281; .111] [.304; 1.94] <.000635>
YD/VG ; PHI/DA ; THE/DB	-.00486 (0) (.00865) (.333) (.333) [.991; .478] <-.107E-5>
YD/VG ; PHI/DA ; PSI/DP	-.0179 (.333) (.526) [.141; .135] [.310; .987] <-.559E-4>
YD/VG ; THE/DB ; PSI/DP	.00646 (.00455) (.182) (.333) (.536) [.163; 2.59] <.642E-5>
XD/WG ; PHI/DA ; THE/DB	-.000395 (0) (0) (.333) (.333) [.554; .597] <-.156E-4>
XD/WG ; PHI/DA ; PSI/DP	.00167 (0) (.0490) (.333) (.365) [-.0188; 3.17] <.000100>
XD/WG ; THE/DB ; PSI/DP	.000530 (0) (.333) [.385; .196] [.318; 1.95] <.258E-4>
ZD/WG ; PHI/DA ; THE/DB	-.0552 (0) (.00708) (.333) (.333) [.453; .905] <-.356E-4>
ZD/WG ; PHI/DA ; PSI/DP	.0341 (0) (.0288) (.333) [.191; .136] [.310; .963] <.559E-5>
ZD/WG ; THE/DB ; PSI/DP	.100 (.00459) (.333) [.297; .105] [.306; 1.95] <.642E-5>
XD/UG ; ZD/DC ; PHI/DA	-.0869 (0) (.333) (.355) [-.242; 1.27] [.529; 1.43] <-.0337>
XD/UG ; ZD/DC ; THE/DB	.0215 (0) (.0411) (.333) [.513; .649] [.274; 1.90] <.000446>
XD/UG ; ZD/DC ; PSI/DP	.155 (.253) [.344; .0662] [.0858; 1.43] [.280; 2.07] <.00152>
YD/VG ; ZD/DC ; PHI/DA	-.255 (0) (-.0739) (.333) [.905; .288] [.286; .976] <.000498>
YD/VG ; ZD/DC ; THE/DB	.103 (0) (.00906) (.333) [.646; .433] [.130; 2.77] <.000446>
YD/VG ; ZD/DC ; PSI/DP	.364 (.184) [.828; .0543] [.362; 1.04] [.130; 2.66] <.00152>
XD/UG ; PHI/DA ; THE/DB ; PSI/DP	.00104 (.0277) (.333) (.333) (.490) <.157E-5>
ZD/UG ; PHI/DA ; THE/DB ; PSI/DP	.0244 (0) (.0283) (.333) (.333) <.765E-4>
YD/VG ; PHI/DA ; THE/DB ; PSI/DP	.00308 (.00839) (.333) (.333) (.547) <.157E-5>
XD/WG ; PHI/DA ; THE/DB ; PSI/DP	.000321 (0) (.0444) (.333) (.333) <.158E-5>
ZD/WG ; PHI/DA ; THE/DB ; PSI/DP	.0596 (.00838) (.0283) (.333) (.333) <.157E-5>
XD/UG ; ZD/DC ; PHI/DA ; THE/DB	.0123 (0) (.333) (.333) [.499; .622] <.000529>
YD/VG ; ZD/DC ; PHI/DA ; THE/DB	.0439 (0) (.0134) (.333) (.333) (.353) <.231E-4>
YD/VG ; ZD/DC ; PHI/DA ; PSI/DP	.168 (.333) [.338; .0810] [.290; .998] <.000365>
XD/WG ; ZD/DC ; PHI/DA ; THE/DB	.00875 (0) (-.0640) (.333) (.333) (.570) <-.355E-4>
XD/UG ; ZD/DC ; PHI/DA ; THE/DB ; PSI/DP	-.0105 (.0310) (.333) (.333) <-.363E-4>
YD/VG ; ZD/DC ; PHI/DA ; THE/DB ; PSI/DP	-.0286 (.0114) (.333) (.333) <-.363E-4>
XD/WG ; ZD/DC ; PHI/DA ; THE/DB ; PSI/DP	-.00519 (.0402) (.333) (.333) <-.232E-4>

TABLE V-5 CONTINUED
UH-IH TRANSFER FUNCTION FACTORS

CASE 125 40KT BAR OFF

DENOMINATOR: (0) (.0861) (1.29) [-.103;.325][.746;.788][.309;1.41]<.0145>

CONTROL NUMERATORS:

PHI/DA .563 (0) [-.243;.365][.939;.733][.384;1.45]<.0844>
THE/DB -.173 (0) (.00216) (.0862) (.785) (1.18) [.307;1.41]<-.591E-4>
PSI/DP -1.17 (1.30) [-.0942;.289][-.0649;.394][.774;.773]<-.0118>

PHI/DB .0256 (0) (.0535) (-.0733) (1.71) (5.12) [.302;1.43]<-.00181>
THE/DA .122 (0) (.0123) (.0808) (.785) [.324;1.51]<.000218>

PHI/DA ;THE/DB -.0972 (0) (.00202) (.785) [.390;1.43]<-.000318>
PHI/DA ;PSI/DP -.687 (.0486) [-.217;.355][.918;.738]<-.00229>
THE/DB ;PSI/DP .204 (.00217) (.777) (1.18) [-.0432;.347]<.488E-4>

PHI/DB ;PSI/DP -.0408 (.0465) [-.0927;.105][.967;2.46]<-.000127>
PHI/DP ;THE/DB -.0558 (0) (.00217) (.763) (-.947) (1.16) <.000101>
PHI/DC ;THE/DB -.00288 (0) (.00192) (4.65) [.901;2.25]<-.000130>

THE/DA ;PSI/DP -.151 (.0109) (.785) [.0645;.384]<-.000191>
THE/DP ;PHI/DA -.0199 (0) (.0109) (.795) (-1.28) (1.81) <.000398>
THE/DC ;PHI/DA .0120 (0) (.0178) (2.04) [.358;.945]<.000389>

PSI/DA ;THE/DB -.0136 (.00201) (.785) (1.71) [-.453;2.00]<-.000146>
PSI/DB ;PHI/DA .0163 (.0466) (.325) (-.621) [-.0316;1.98]<-.000602>
XD/DB ;PHI/DA .591 (0) (.768) [.388;1.43][.0407;2.33]<5.04>

YD/DA ;THE/DB -.151 (.00201) (.785) [.357;1.42][.00881;4.55]<-.00986>
ZD/DB ;PHI/DA .931 (0) (-.0600) [.399;1.44][.0975;2.35]<-.636>
XD/DC ;PHI/DA -.0270 (0) (1.87) [.343;.957][-.0733;3.91]<-.707>

YD/DP ;THE/DB -.274 (.00217) (.760) (1.16) (-1.23) [.175;2.26]<.00329>
ZD/DC ;PHI/DA -5.83 (0) (.531) [-.0766;.395][.357;1.44]<-.999>

PHI/DA ;THE/DB ;PSI/DP .119 (.00253) (.0485) (.782) <.115E-4>
PHI/DC ;THE/DB ;PSI/DP .0182 (.00308) (.0439) (1.71) <.421E-5>
THE/DC ;PHI/DA ;PSI/DP -.00945 (.0145) (.0545) (2.14) <-.159E-4>

PSI/DC ;PHI/DA ;THE/DB -.0256 (0) (.0630) (1.21) <-.00195>
XD/DB ;PHI/DA ;PSI/DP -.721 (.0485) (.764) [.0420;2.33]<-.145>
YD/DA ;THE/DB ;PSI/DP .200 (.00254) (.782) [-.00878;4.35]<.00755>

ZD/DC ;PHI/DA ;THE/DB .987 (0) (.00338) [.378;1.42]<.00670>
ZD/DC ;PHI/DA ;PSI/DP 7.12 (.0478) (.420) [.0216;.435]<.0271>
XD/DC ;PHI/DA ;THE/DB -.00792 (0) (2.58) [.237;1.00]<-.0206>

XD/DC ;PHI/DA ;PSI/DP .0366 (.0539) (1.82) [-.152;3.12]<.0351>
YD/DP ;PHI/DA ;THE/DB -.105 (.00253) (.780) (1.89) (-1.96) <.000774>
ZD/DB ;PHI/DA ;PSI/DP -1.14 (.0485) (-.0565) [.0974;2.36]<.0173>

ZD/DC ;PHI/DA ;THE/DB ;PSI/DP -1.22 (.00428) (.0489) <-.000256>
XD/DC ;PHI/DA ;THE/DB ;PSI/DP .00357 (.0521) (4.49) <.000835>

TABLE V-5 CONTINUED
UH-IH TRANSFER FUNCTION FACTORS

CASE I26 60KT BAR OFF

DENOMINATOR: (0) (.0626) (1.47) [-.00588; .283] [.644; .916] [.331; 1.89] <.0222>
S R P SP D

CONTROL NUMERATORS:

PHI/DA .563 (0) [-.143; .348] [.875; .871] [.363; 1.94] <.194>
 THE/DB -.174 (0) (.00612) (.0600) (1.00) (1.11) [.329; 1.89] <-.000252>
 PSI/DP -1.43 (1.47) [-.0541; .270] [.0899; .341] [.670; .894] <-.0142>

PHI/DB .0442 (0) (.154) (-.164) [.290; 1.88] [.794; 2.94] <-.0343>
 PHI/DP .408 (0) (-1.05) (1.45) [-.0325; .283] [.749; .942] <-.0440>
 PHI/DC .134 (0) (.710) [-.275; .411] [.727; 2.38] <.0907>

THE/DA .117 (0) (.912) [.858; .0311] [.331; 1.97] <.000400>
 THE/DP -.0298 (0) (.00470) (.798) (1.44) (-2.09) [-.0408; .180] <.108E-4>
 THE/DC .0149 (0) (.0269) (.0366) (1.97) (2.96) [.171; 1.94] <.000323>

PSI/DA .0791 (.899) [-.117; .345] [.882; 1.32] [-.370; 2.02] <.0600>
 PSI/DB .0596 (.155) (-.168) (1.39) [-.0734; 1.10] [.177; 2.02] <-.0107>
 PSI/DC .210 (1.72) [-.368; .396] [.0330; .691] [.983; 1.02] <.0283>

XD/DB 1.03 (0) (.0614) (.983) (1.11) [.328; 1.88] [.0533; 2.36] <1.36>
 YD/DA .875 [-.139; .350] [.860; .867] [.331; 1.90] [.0110; 4.57] <6.07>
 ZD/DC -11.6 (0) (.0599) (.133) (1.36) [-.172; .757] [.325; 1.89] <-.257>

XD/DC .0217 (0) (.0547) (1.98) (-7.62) [.164; 1.71] [.757; 3.31] <-.574>
 YD/DP 1.95 (1.43) (-1.82) [-.0312; .282] [.791; .981] [.279; 1.92] <-1.44>
 ZD/DB 2.75 (0) (.00223) (.0631) (1.19) [.332; 1.89] [-.138; 2.44] <.00985>

PHI/DA ; THE/DB -.0978 (0) (.00468) (.924) [.367; 1.93] <-.00158>
 PHI/DA ; PSI/DP -.838 (.0721) [-.127; .343] [.858; .879] <-.00550>
 THE/DB ; PSI/DP .250 (.00606) (.954) (1.15) [.0244; .316] <.000167>

PHI/DB ; PSI/DP -.0876 (.0737) (.144) (-.158) [.650; 2.40] <.000846>
 PHI/DP ; THE/DB -.0695 (0) (.00605) (.881) (-1.02) (1.37) <.000516>
 PHI/DC ; THE/DB -.0259 (0) (.00365) [.743; 2.37] <-.000529>

THE/DA ; PSI/DP -.175 (.0183) (.911) [.0998; .313] <-.000287>
 THE/DP ; PHI/DA -.0179 (0) (.0181) (.956) (-1.35) (2.14) <.000891>
 THE/DC ; PHI/DA .00838 (0) (.0163) (3.48) [.322; 1.58] <.00119>

PSI/DA ; THE/DB -.0139 (.00468) (.911) (1.99) [-.319; 2.03] <-.000488>
 PSI/DB ; PHI/DA .0301 (.0648) (.242) (-.248) [.101; 2.18] <-.000557>
 PSI/DC ; THE/DB -.0374 (.00365) [-.178; .683] [.994; 1.61] <-.000165>

PSI/DC ; PHI/DA .118 (.0883) (1.03) (1.31) [-.211; .374] <.00197>
 XD/DB ; PHI/DA .578 (0) (.906) [.366; 1.93] [.0552; 2.37] <10.9>
 XD/DB ; PSI/DP -1.47 (.925) (1.16) [.0337; .318] [.0548; 2.37] <-.887>

YD/DA ; THE/DB -.152 (.00468) (.925) [.330; 1.89] [.0108; 4.58] <-.0494>
 YD/DA ; PSI/DP -1.41 [-.127; .344] [.853; .878] [-.0105; 4.34] <-2.41>
 ZD/DC ; PHI/DA -6.50 (0) (.412) [-.159; .499] [.351; 1.92] <-2.47>

ZD/DC ; THE/DB 1.96 (0) (.00655) (.0520) (1.18) [.324; 1.87] <.00277>
 ZD/DC ; PSI/DP 16.6 (.193) (1.36) [.0304; .306] [.174; .744] <.226>
 XD/DC ; PHI/DA .0122 (0) (-6.84) [.322; 1.54] [.693; 3.44] <-2.34>

XD/DC ; THE/DB -.0190 (0) (.161) (1.12) (2.04) [.311; 1.38] <-.0133>
 XD/DC ; PSI/DP .262 (1.94) [.0658; .318] [.431; 2.82] <.410>
 YD/DP ; PHI/DA .739 (2.84) (-2.92) [-.122; .341] [.849; .883] <-.557>

YD/DP ; THE/DB -.336 (.00606) (.863) (1.46) (-1.82) [.304; 1.91] <.0169>
 ZD/DB ; PHI/DA 1.55 (0) (.00492) [-.374; 1.94] [.130; 2.42] <.168>
 ZD/DB ; PSI/DP -3.94 (.0106) (1.21) [-.00701; .312] [.135; 2.45] <-.0295>

PHI/DA ; THE/DB ; PSI/DP -.147 (.00488) (.0720) (.920) <.474E-4>
 PHI/DC ; THE/DB ; PSI/DP .0154 (.00348) (.0687) (3.17) <.117E-4>
 THE/DC ; PHI/DA ; PSI/DP -.00872 (.0167) (.0747) (3.94) <-.428E-4>

TABLE V-5 CONTINUED
UH-IH TRANSFER FUNCTION FACTORS

CASE I26 60KT BAR OFF

CONTROL NUMERATORS CONCLUDED:

PSI/DC ; PHI/DA ; THE/DB -0.210 (.00394) (.0900) (1.70) <- .126E-4>
 XD/DB ; PHI/DA ; PSI/DP -0.860 (.0719) (.900) [.0562; 2.37] <- .312>
 YD/DA ; THE/DB ; PSI/DP .246 (.00489) (.921) [-.00683; 4.34] <.0208>
 ZD/DC ; PHI/DA ; THE/DB 1.11 (0) (.00468) [.360; 1.92] <.0191>
 ZD/DC ; THE/DB ; PSI/DP -2.85 (.00572) (1.20) [-.00520; .335] <- .00219>
 ZD/DC ; PHI/DA ; PSI/DP 9.69 (.0719) (.352) [.178; .546] <.0730>
 XD/DC ; PHI/DA ; THE/DB -0.107 (0) (2.02) [-.367; 1.48] <- .0477>
 XD/DC ; PHI/DA ; PSI/DP -0.125 (.0748) (-8.08) [.589; 3.31] <.0824>
 XD/DC ; THE/DB ; PSI/DP .0136 (1.19) (2.07) [-.0789; .442] <.00900>
 YD/DP ; PHI/DA ; THE/DB -0.128 (.00488) (.918) (2.85) (-2.93) <.00480>
 ZD/DB ; PHI/DA ; PSI/DP -2.31 (.00577) (.0720) [.130; 2.43] <- .00567>
 ZD/DC ; PHI/DA ; THE/DB ; PSI/DP -1.67 (.00484) (.0724) <- .000585>
 XD/DC ; PHI/DA ; THE/DB ; PSI/DP .0111 (.0752) (2.06) <.00172>

GUST NUMERATORS:

PHI/UG .00150 (0) (0) (0) [.514; 1.60] [.593; 2.73] <.0286>
 THE/UG -.00300 (0) (0) (.0632) [.996; .000] [.345; 1.91] <- .000689>
 PSI/UG .00390 (0) (0) (1.39) [-.202; .933] [.520; 1.37] <.00889>
 PHI/VG .0138 (0) (0) (.709) [-.0331; .293] [.746; .907] <.000690>
 THE/VG -.00125 (0) (0) (0) (-.0792) (-.344) [.939; .715] <- .174E-4>
 PSI/VG -.0334 (0) (0) (1.49) [-.00296; .285] [.648; .901] <- .00327>
 PHI/WG .00688 (0) (0) (.663) [-.309; .429] [.355; 2.54] <.00543>
 THE/WG .00308 (0) (0) (.0213) (.0418) (1.97) [.248; 1.87] <.189E-4>
 PSI/WG .0151 (0) (.727) (1.34) [-.358; .418] [-.0137; .812] <.00169>
 PHI/PG 1.12 (0) [-.0466; .277] [.776; 1.03] [.367; 1.95] <.345>
 THE/PG -.202 (0) (-.0480) (.925) [.340; .131] [.353; 1.91] <.000560>
 PSI/PG .284 (1.23) [-.0449; .278] [.704; 1.18] [-.244; 1.68] <.107>
 PHI/QG .773 (0) (.327) (1.29) [-.714; .535] [.356; 1.99] <.371>
 THE/QG .523 (0) (.0176) (.0518) (.840) (1.59) [.320; 1.90] <.00230>
 PSI/QG .0368 (.320) (-.816) (1.54) (3.23) (-5.06) [-.432; .689] <.115>
 PHI/RG -.290 (0) (1.62) (-1.71) [-.0584; .289] [.767; 1.02] <.0699>
 THE/RG .00921 (0) (0) (1.15) (2.00) (-6.70) [-.711; .113] <- .00182>
 PSI/RG 1.27 (1.46) [-.0979; .284] [.0465; .424] [.698; .907] <.0222>
 XD/UG .0230 (0) (.0629) (.913) (1.06) [.363; 1.90] [.0570; 2.09] <.0222>
 ZD/UG .0459 (0) (0) (.0625) (1.08) [.324; 1.92] [.182; 2.47] <.0697>
 YD/VG .125 (0) (.667) [-.0353; .292] [.758; .919] [.298; 1.92] <.0222>
 XD/WG -.00827 (0) (0) (.0553) (2.11) [.229; 1.76] [.0999; 3.55] <- .0376>
 ZD/WG .877 (0) (.0626) [-.175; .346] [.974; .975] [.333; 1.88] <.0222>
 PHI/UG ; THE/DB -.000128 (0) (0) (.939) [.428; 2.98] <- .00107>
 PHI/UG ; PSI/DP -.00374 (0) (0) (.0696) [.636; 1.67] <- .000728>
 THE/UG ; PHI/DA -.00169 (0) (0) (.922) [.363; 1.97] <- .00603>
 THE/UG ; PSI/DP .00441 (0) (.972) (1.03) [.0175; .316] <.000442>
 PSI/UG ; PHI/DA .00208 (0) (0) (.102) [.434; 1.31] <.000365>
 PSI/UG ; THE/DB -.000499 (0) (.943) (1.37) [-.148; .719] <- .000332>
 PHI/VG ; THE/DB -.00233 (0) (0) (.00597) [.979; .750] <- .784E-5>
 PHI/VG ; PSI/DP -.00609 (0) [-.0263; .283] [.760; .954] <- .000443>
 THE/VG ; PHI/DA -.000742 (0) (0) (.0196) (.640) (1.34) <- .125E-4>
 THE/VG ; PSI/DP .000798 (0) (0) (.731) [-.156; .148] <.128E-4>
 PSI/VG ; PHI/DA -.0199 (0) [-.140; .349] [.872; .879] <- .00187>
 PSI/VG ; THE/DB .00587 (0) (0) (.00451) [.995; 1.04] <.287E-4>

TABLE V-5 CONTINUED
UH-IH TRANSFER FUNCTION FACTORS

CASE I26 60KT BAR OFF

GUST NUMERATORS CONTINUED:

PHI/WG ; THE/DB	- .00133 (0) (0) (.00380) [.390; 2.53] <-.324E-4>
PHI/WG ; PSI/DP	- .0160 (0) (.0678) (.641) [-.333; .433] <-.000130>
THE/WG ; PHI/DA	.00172 (0) (0) (.0128) [.391; 1.75] <.674E-4>
THE/WG ; PSI/DP	- .00397 (0) (.0157) (2.08) [.0570; .316] <-.130E-4>
PSI/WG ; PHI/DA	.00795 (0) (.107) (.763) [-.246; .400] <.000104>
PSI/WG ; THE/DB	- .00280 (0) (.00380) (1.43) [-.150; .814] <-.101E-4>
PHI/PG ; THE/DB	- .186 (0) (.00454) (.944) [.365; 1.96] <-.00305>
PHI/PG ; PSI/DP	-1.72 (.0715) [-.0458; .278] [.772; 1.01] <-.00979>
THE/PG ; PHI/DA	- .117 (0) (.00333) (.903) [.364; 1.94] <-.00133>
THE/PG ; PSI/DP	.298 (-.132) (.193) (.932) [-.0336; .241] <-.000412>
PSI/PG ; PHI/DA	.0712 (.0153) (-.126) (.201) [.328; 1.71] <-.806E-4>
PSI/PG ; THE/DB	- .0373 (.00453) (.936) (1.93) [-.276; 1.75] <-.000940>
PHI/QG ; THE/DB	- .157 (0) (.00136) (.787) [.382; 1.97] <-.000651>
PHI/QG ; PSI/DP	-1.12 (.0725) (.340) (1.27) [-.676; .540] <-.0102>
THE/QG ; PHI/DA	.292 (0) (.0141) (.876) [.365; 1.93] <.0134>
THE/QG ; PSI/DP	- .748 (.0154) (.837) (1.59) [.0415; .317] <-.00153>
PSI/QG ; PHI/DA	- .0404 (.0603) (.218) (-.219) [.181; 3.27] <.00125>
PSI/QG ; THE/DB	- .0376 (.00133) (.752) (1.70) [-.395; 1.75] <-.000196>
PHI/RG ; THE/DB	.0499 (0) (.00596) (1.18) (1.38) (-1.64) <-.000793>
PHI/RG ; PSI/DP	- .103 (.0732) [-.0928; .296] [.862; 1.15] <-.000880>
THE/RG ; PHI/DA	.00597 (0) (.0197) (.803) (-3.36) (3.99) <-.00126>
THE/RG ; PSI/DP	.0246 (.0112) (-.381) (1.27) [.126; .287] <-.109E-4>
PSI/RG ; PHI/DA	.737 (.0711) [-.122; .340] [.853; .894] <.00485>
PSI/RG ; THE/DB	- .221 (.00597) [-.0491; .400] [.999; 1.09] <-.000252>
XD/UG ; PHI/DA	.0130 (0) (.895) [.381; 1.96] [.0552; 2.08] <.194>
XD/UG ; THE/DB	- .000920 (0) (.0806) (.990) (1.11) [.328; 1.76] <-.000251>
XD/UG ; PSI/DP	- .0327 (.862) (1.12) [.0274; .317] [.0818; 2.12] <-.0142>
ZD/UG ; PHI/DA	.0259 (0) (0) [.343; 2.01] [.172; 2.42] <.611>
ZD/UG ; THE/DB	.000285 (0) (0) (.445) (-3.01) [.447; 1.13] <-.000484>
ZD/UG ; PSI/DP	- .0655 (0) (1.12) [-.0149; .312] [.141; 2.51] <-.0448>
YD/VG ; PHI/DA	.0584 (0) (.899) [-.116; .337] [.824; .903] <.00485>
YD/VG ; THE/DB	- .0216 (0) (.00597) [.981; .733] [.314; 1.90] <-.000252>
YD/VG ; PSI/DP	- .114 [-.0249; .282] [.823; .955] [.357; 1.31] <-.0142>
XD/WG ; PHI/DA	- .00454 (0) (0) [.373; 1.71] [.0286; 3.57] <-.169>
XD/WG ; THE/DB	- .00173 (0) (0) (.177) (1.12) [.320; 1.46] <-.000731>
XD/WG ; PSI/DP	.0127 (0) (2.29) [.0644; .318] [.0986; 3.00] <.0266>
ZD/WG ; PHI/DA	.493 (0) (.730) [-.249; .380] [.374; 1.93] <.194>
ZD/WG ; THE/DB	- .161 (0) (.00612) (.0597) (1.20) [.336; 1.89] <-.000252>
ZD/WG ; PSI/DP	-1.25 [-.0905; .313] [-.0771; .350] [.982; .971] <-.0142>
XD/UG ; ZD/DC	- .267 (0) (.0576) (1.08) [.356; 1.87] [.0622; 2.10] <-.257>
YD/VG ; ZD/DC	-1.44 (0) (.141) (.673) [.230; .712] [.299; 1.93] <-.257>
PHI/UG ; THE/DB ; PSI/DP	.000385 (0) (.0726) (.942) <.263E-4>
THE/UG ; PHI/DA ; PSI/DP	.00258 (0) (.0720) (.918) <.000171>
PSI/UG ; PHI/DA ; THE/DB	- .000271 (0) (.0684) (.934) <-.173E-4>
PHI/VG ; THE/DB ; PSI/DP	.00102 (0) (.00605) (.846) <.519E-5>
THE/VG ; PHI/DA ; PSI/DP	.000473 (0) (.0181) (1.04) <.893E-5>
PSI/VG ; PHI/DA ; THE/DB	.00349 (0) (.00468) (.930) <.152E-4>
PHI/WG ; THE/DB ; PSI/DP	.00304 (0) (.00371) (.0670) <.756E-6>
THE/WG ; PHI/DA ; PSI/DP	- .00230 (0) (.0137) (.0756) <-.239E-5>
PSI/WG ; PHI/DA ; THE/DB	- .00147 (0) (.00396) (.112) <-.652E-6>

TABLE V-5 CONTINUED
UH-IH TRANSFER FUNCTION FACTORS

CASE I26 60KT BAR OFF

GUST NUMERATORS CONCLUDED:

PHI/PG ; THE/DB ; PSI/DP	.283	{.00474}	{.0716}	{.939}	<.902E-4>	
THE/PG ; PHI/DA ; PSI/DP	.176	{.00335}	{.0716}	{.897}	<.379E-4>	
PSI/PG ; PHI/DA ; THE/DB	-.00615	{.00317}	{.120}	{1.35}	<-.315E-5>	
PHI/QG ; THE/DB ; PSI/DP	.242	{.00207}	{.0721}	{.795}	<.287E-4>	
THE/QG ; PHI/DA ; PSI/DP	-.437	{.0141}	{.0719}	{.868}	<-.000386>	
PSI/QG ; PHI/DA ; THE/DB	-.00859	{.0374}	{.106}	{-.832}	<.283E-4>	
PHI/RG ; THE/DB ; PSI/DP	.0165	{.00587}	{.0732}	{1.36}	<.966E-5>	
THE/RG ; PHI/DA ; PSI/DP	.0145	{.0231}	{.0745}	{.541}	<.135E-4>	
PSI/RG ; PHI/DA ; THE/DB	-.128	{.00500}	{.0710}	{.946}	<-.432E-4>	
XD/UG ; PHI/DA ; THE/DB	-.000519	{0}	{.927}	[.372; 1.81]	<-.00158>	
XD/UG ; PHI/DA ; PSI/DP	-.0192	{.0720}	{.887}	[.0774; 2.12]	<-.00550>	
XD/UG ; THE/DB ; PSI/DP	.00121	{.951}	{1.16}	[-.00398; .353]	<.000167>	
ZD/UG ; PHI/DA ; THE/DB	.000164	{0}	{0}	[-.694; 1.24]	<.000251>	
ZD/UG ; PHI/DA ; PSI/DP	-.0384	{0}	{.0720}	[.127; 2.50]	<-.0173>	
ZD/UG ; THE/DB ; PSI/DP	-.000675	{0}	{.887}	[-.363; .810]	<-.000393>	
YD/VG ; PHI/DA ; THE/DB	-.0101	{0}	{.00500}	[.983; .923]	<-.432E-4>	
YD/VG ; PHI/DA ; PSI/DP	-.0609	[-.123; .341]	[.850; .881]	<-.00550>		
YD/VG ; THE/DB ; PSI/DP	.0198	{.00606}	{.826}	[.426; 1.30]	<.000167>	
XD/WG ; PHI/DA ; THE/DB	-.000975	{0}	{0}	[.392; 1.57]	<-.00240>	
XD/WG ; PHI/DA ; PSI/DP	.00714	{0}	{.0759}	[.00573; 3.22]	<.00563>	
XD/WG ; THE/DB ; PSI/DP	.00183	{0}	{1.19}	[-.0781; .477]	<.000496>	
ZD/WG ; PHI/DA ; THE/DB	-.0905	{0}	{.00468}	[.375; 1.93]	<-.00158>	
ZD/WG ; PHI/DA ; PSI/DP	-.735	{.0720}	{.726}	[-.247; .378]	<-.00550>	
ZD/WG ; THE/DB ; PSI/DP	.230	{.00606}	{1.22}	[.0102; .314]	<.000167>	
XD/UG ; ZD/DC ; PHI/DA	-.151	{0}	[.373; 1.93]	[.0600; 2.09]	<-2.47>	
XD/UG ; ZD/DC ; THE/DB	.0104	{0}	{.0746}	{1.17}	[.324; 1.75]	<.00277>
XD/UG ; ZD/DC ; PSI/DP	.379	{1.12}	[-.0166; .343]	[.0808; 2.13]	<.226>	
YD/VG ; ZD/DC ; PHI/DA	-.671	{0}	{.275}	{.901}	[.199; .600]	<-.0599>
YD/VG ; ZD/DC ; THE/DB	.244	{0}	{.00632}	{.491}	[.311; 1.91]	<.00277>
YD/VG ; ZD/DC ; PSI/DP	1.32	{.216}	[.423; .701]	[.327; 1.27]	<.226>	
XD/UG ; PHI/DA ; THE/DB ; PSI/DP	.000714	{.0718}	{.924}	<.474E-4>		
ZD/UG ; PHI/DA ; THE/DB ; PSI/DP	-.000393	{0}	{.0694}	<-.273E-4>		
YD/UG ; PHI/DA ; THE/DB ; PSI/DP	.0106	{.00488}	{.914}	<.474E-4>		
XD/WG ; PHI/DA ; THE/DB ; PSI/DP	.00111	{0}	{.0781}	<.871E-4>		
ZD/WG ; PHI/DA ; THE/DB ; PSI/DP	.135	{.00488}	{.0720}	<.474E-4>		
XD/UG ; ZD/DC ; PHI/DA ; THE/DB	.00585	{0}	[.366; 1.81]	<.0191>		
YD/VG ; ZD/DC ; PHI/DA ; THE/DB	.114	{0}	{.00504}	{.867}	<.000501>	
YD/VG ; ZD/DC ; PHI/DA ; PSI/DP	.703	{.339}	[.187; .554]	<.0730>		
XD/WG ; ZD/DC ; PHI/DA ; THE/DB	.0210	{0}	[.394; 1.51]	<.0477>		
XD/UG ; ZD/DC ; PHI/DA ; THE/DB ; PSI/DP	-.00810	{.0722}	<-.000585>			
YD/VG ; ZD/DC ; PHI/DA ; THE/DB ; PSI/DP	-.121	{.00484}	<-.000585>			
XD/WG ; ZD/DC ; PHI/DA ; THE/DB ; PSI/DP	-.0229	{.0751}	<-.00172>			

TABLE V-5 CONTINUED
UH-IH TRANSFER FUNCTION FACTORS

CASE I26 60KT BAR ON

DENOMINATOR: (0) (.0105) (.810) [-.202; .177] [.462; 1.07] [.466; 1.88] [.242; 2.04] <-.00453>

CONTROL NUMERATORS:

PHI/DA .563 (0) (.333) (.793) [-.205; .179] [.409; 1.10] [.362; 1.94] <-.0216>
THE/DB -.174 (0) (.00618) (.00991) (.333) (.921) [.496; 1.86] [.238; 2.03] <-.464E-4>
PSI/DP -1.43 (.800) [.492; .0949] [-.232; .181] [.442; 1.08] [.357; 2.01] <-.00158>

PHI/DB .0442 (0) (.155) (-.163) (.333) (.337) [.292; 1.88] [.798; 2.92] <-.00379>
PHI/DP .408 (0) (.395) (.647) (-.955) (1.30) [.184; .159] [.422; 1.20] <-.00470>
PHI/DC .134 (0) (.340) [-.240; .199] [.375; 1.01] [.714; 2.34] <.0100>

THE/DA -.117 (0) (.0140) (.103) (.268) (.333) (.912) [.334; 1.97] <.536E-4>
THE/DP -.0298 (0) (.00581) (.0161) (.379) (.952) (-1.51) (1.62) [-.172; 1.90] <.895E-5>
THE/DC .0149 (0) (.0132) (.0217) (.327) (3.15) [-.619; 1.46] [-.210; 2.37] <.528E-4>

PSI/DA .0791 (.333) (.918) (1.38) [.207; .178] [.465; 1.23] [-.374; 2.04] <.00666>
PSI/DB .0596 (.178) (-.181) (.333) [-.763; .322] [.00646; 1.90] [.393; 2.23] <-.00119>
PSI/DC .210 (1.54) [.212; .209] [.501; .246] [.478; .996] [.344; 1.93] <.00314>

XD/DB 1.03 (0) (.0114) (.333) (.903) [-.494; 1.86] [.243; 2.03] [.0502; 2.36] <.278>
YD/DA .875 (.333) (.784) [-.207; .179] [.393; 1.10] [.331; 1.90] [.0110; 4.57] <.675>
ZD/DC -11.6 (0) (.00980) [.486; .166] [-.399; 1.13] [.444; 1.84] [.248; 2.02] <-.0553>

XD/DC .0217 (0) (.0198) (.359) (-7.26) [.635; 1.49] [.178; 2.05] [.731; 3.36] <-.118>
YD/DP 1.95 (.107) (.763) (1.92) (-2.01) [-.232; .167] [.425; 1.14] [-.197; 2.69] <-.160>
ZD/DB 2.75 (0) (.00304) (.0131) (.333) [-.502; 1.85] [-.228; 2.03] [-.149; 2.45] <.00307>

PHI/DA ; THE/DB -.0978 (0) (.00468) (.333) (.333) (.924) [.367; 1.93] <-.000176>
PHI/DA ; PSI/DP -.838 (.0720) (.333) (.782) [.206; .177] [.403; 1.12] <-.000611>
THE/DB ; PSI/DP .250 (.00610) (.333) (.919) [.500; .101] [.366; 1.96] <.185E-4>

PHI/DB ; PSI/DP -.0876 (.0737) (.144) (-.158) (.333) (.335) [.650; 2.40] <.940E-4>
PHI/DP ; THE/DB -.0695 (0) (.00610) (.333) (.394) (.858) (-.933) (1.25) <.556E-4>
PHI/DC ; THE/DB -.0259 (0) (.00364) (.333) (.340) [.732; 2.33] <-.582E-4>

THE/DA ; PSI/DP -.175 (.0183) (.333) (.333) (.911) [.0998; .313] <-.318E-4>
THE/DP ; PHI/DA -.0179 (0) (.0184) (.333) (.378) (.967) (-1.24) (1.97) <.981E-4>
THE/DC ; PHI/DA .00838 (0) (.0162) (.327) (.333) (3.46) [.327; 1.61] <.000133>

PSI/DA ; THE/DB -.0139 (.00468) (.333) (.333) (.911) (1.99) [-.319; 2.03] <-.542E-4>
PSI/DB ; PHI/DA .0301 (.0648) (.242) (-.248) (.333) (.333) [.101; 2.18] <-.619E-4>
PSI/DC ; THE/DB -.0374 (.00365) (.333) (1.68) [.527; .264] [.358; 1.86] <-.183E-4>

PSI/DC ; PHI/DA .118 (.0886) (.333) (1.53) [-.218; .193] [.429; 1.05] <.000219>
XD/DB ; PHI/DA .578 (0) (.333) (.333) (.906) [.366; 1.93] [.0552; 2.37] <1.21>
XD/DB ; PSI/DP -1.47 (.333) (.899) [.506; .102] [.367; 1.96] [.0536; 2.37] <-.0985>

YD/DA ; THE/DB -.152 (.00468) (.333) (.333) (.925) [.330; 1.89] [.0108; 4.58] <-.00549>
YD/DA ; PSI/DP -1.41 (.333) (.778) [-.206; .177] [.400; 1.12] [-.0106; 4.34] <-.268>
ZD/DC ; PHI/DA -6.50 (0) (.333) [-.469; .168] [.344; 1.10] [.348; 1.92] <-.274>

ZD/DC ; THE/DB 1.96 (0) (.00722) (.00806) (.333) [.490; 1.86] [-.237; 2.01] <.000531>
ZD/DC ; PSI/DP 16.6 [-.629; .101] [-.434; .174] [.358; 1.12] [.357; 1.98] <.0251>
XD/DC ; PHI/DA .0122 (0) (.333) (.358) (-6.47) [.320; 1.58] [.650; 3.35] <-.262>

XD/DC ; THE/DB -.0190 (0) (.0187) (.333) (2.03) [-.467; 1.69] [-.258; 1.72] <-.00203>
XD/DC ; PSI/DP .254 (.367) [-.458; .133] [.696; 1.99] [.262; 2.63] <.0455>
YD/DP ; PHI/DA .739 (.333) (.775) (2.84) (-2.92) [.205; .176] [.403; 1.12] <-.0618>

YD/DP ; THE/DB -.336 (.00610) (.109) (.333) (.908) (1.94) (-2.02) [-.199; 2.66] <.00188>
ZD/DB ; PHI/DA 1.55 (0) (.00492) (.333) (.333) [.374; 1.94] [-.130; 2.42] <.0187>
ZD/DB ; PSI/DP -3.94 (.0109) (.333) [-.479; .100] [.360; 1.94] [.143; 2.45] <-.00328>

PHI/DA ; THE/DB ; PSI/DP .147 (.00488) (.0720) (.333) (.333) (.920) <.526E-5>
PHI/DC ; THE/DB ; PSI/DP .0154 (.00348) (.0687) (.333) (.333) (3.17) <.130E-5>
THE/DC ; PHI/DA ; PSI/DP -.00872 (.0167) (.0747) (.333) (.333) (3.94) <-.476E-5>

TABLE V-5 CONTINUED
UH-IH TRANSFER FUNCTION FACTORS

CASE I26 60KT BAR ON

CONTROL NUMERATORS CONCLUDED:

PSI/DC ; PHI/DA ; THE/DB - .0210 (.00394) (.0900) (.333) (.333) (1.70) <-.140E-5>
 XD/DB ; PHI/DA ; PSI/DP - .860 (.0719) (.333) (.333) (.900) [-.0562; 2.37] <-.0347>
 YD/DA ; THE/DB ; PSI/DP .246 (.00489) (.333) (.333) (.921) [-.00683; 4.34] <.00232>
 ZD/DC ; PHI/DA ; THE/DB 1.11 (0) (.00468) (.333) (.333) [.360; 1.92] <.00212>
 ZD/DC ; THE/DB ; PSI/DP -2.85 (.00575) (.333) [.487; .108] [.364; 1.96] <-.000244>
 ZD/DC ; PHI/DA ; PSI/DP 9.69 (.0720) (.333) [.505; .167] [.317; 1.12] <.00811>
 XD/DC ; PHI/DA ; THE/DB -.0107 (0) (.333) (.333) (2.02) [-.367; 1.48] <-.00530>
 XD/DC ; PHI/DA ; PSI/DP -.0125 (.0748) (.333) (.367) (-7.66) [-.532; 3.24] <.00916>
 XD/DC ; THE/DB ; PSI/DP .0186 (.333) (2.06) [.467; .143] [.341; 1.96] <.00100>
 YD/DP ; PHI/DA ; THE/DB -.128 (.00488) (.333) (.333) (.918) (2.85) (-2.93) <.000533>
 ZD/DB ; PHI/DA ; PSI/DP -2.31 (.00577) (.0720) (.333) (.333) [-.130; 2.43] <-.000630>
 ZD/DC ; PHI/DA ; THE/DB ; PSI/DP -1.67 (.00484) (.0724) (.333) (.333) <-.650E-4>
 XD/DC ; PHI/DA ; THE/DB ; PSI/DP .0111 (.0752) (.333) (.333) (2.06) <.000191>

GUST NUMERATORS:

PHI/UG .00150 (0) (0) (0) (.342) (-.458) [-.421; 1.67] [-.609; 2.74] <.00494>
 THE/UG -.00300 (0) (0) (.0105) (.334) (.920) [.476; 1.93] [.237; 1.98] <-.000141>
 PSI/UG .00390 (0) (0) (-.555) [-.648; .296] [-.212; 1.48] [-.400; 1.93] <.00154>
 PHI/VG .0138 (0) (0) (-.684) [-.185; .161] [.771; .638] [.413; 1.19] <.000141>
 THE/VG -.00125 (0) (0) (0) (.0136) (1.05) [-.830; .660] [-.140; 2.02] <-.318E-4>
 PSI/VG -.0334 (0) (0) (-.816) [-.198; .177] [.452; 1.08] [.362; 2.02] <-.00406>
 PHI/WG .00688 (0) (0) (-.338) [-.254; .203] [-.330; .994] [-.353; 2.51] <.000600>
 THE/WG .00308 (0) (0) (.329) [-.995; .0154] [-.675; 1.65] [-.240; 2.18] <.307E-5>
 PSI/WG .0151 (0) [-.247; .205] [-.604; .308] [-.420; .929] [-.305; 1.90] <.000188>
 PHI/PG 1.12 (0) (.334) (.712) [-.171; .159] [.460; 1.23] [-.368; 1.94] <.0383>
 THE/PG -.202 (0) (-.00673) (.0120) (.334) (.906) [-.385; 1.89] [-.0739; 1.90] <.642E-4>
 PSI/PG .284 (-.357) [-.156; .163] [-.809; .736] [-.584; 1.51] [-.173; 1.88] <.0118>
 PHI/QG .773 (0) (.332) (1.04) [-.446; .269] [-.0388; .734] [.349; 1.99] <.0412>
 THE/QG .523 (0) (.0132) (.0143) (.334) (.880) [-.551; 1.86] [-.268; 2.04] <.000415>
 PSI/QG .0368 (-.294) (-.596) (-.806) (3.95) (-5.45) [-.378; .216] [-.172; 1.56] <.0128>
 PHI/RG -.290 (0) (.363) (.808) (1.45) (-1.62) [-.183; .162] [.437; 1.20] <.00760>
 THE/RG .00921 (0) (.00511) (.0167) (.370) (.812) (2.49) (-6.21) [-.156; 1.69] <-.105E-4>
 PSI/RG 1.27 (.810) [-.405; .124] [-.264; .181] [.439; 1.09] [-.355; 2.00] <.00246>
 XD/UG .0230 (0) (.0105) (.321) (.896) [-.481; 1.92] [-.243; 1.97] [-.0686; 2.13] <.00453>
 ZD/UG .0459 (0) (0) (.0105) (.335) [-.481; 1.94] [-.208; 1.94] [-.188; 2.50] <.0143>
 YD/VG .125 (0) (.342) [-.205; .161] [-.950; .685] [-.419; 1.15] [-.230; 2.56] <.00454>
 XD/WG -.00827 (0) (0) (.0184) (-.354) [-.682; 1.71] [-.205; 2.08] [-.117; 3.37] <-.00774>
 ZD/WG .877 (0) (.0105) [-.221; .186] [-.407; .973] [-.496; 1.88] [-.246; 2.06] <.00453>
 PHI/UG ; THE/DB -.000128 (0) (0) (.333) (.341) (.940) [-.433; 2.93] <-.000118>
 PHI/UG ; PSI/DP -.00374 (0) (0) (-.0708) (.333) (.455) [-.569; 1.76] <-.000125>
 THE/UG ; PHI/DA -.00169 (0) (0) (.333) (.334) (.922) [-.364; 1.96] <-.000670>
 THE/UG ; PSI/DP .00441 (0) (.333) (.917) [-.515; .0977] [-.341; 1.96] <.491E-4>
 PSI/UG ; PHI/DA .00208 (0) (0) (.0827) (.333) (.533) [-.319; 1.51] <.693E-4>
 PSI/UG ; THE/DB -.000499 (0) (.333) (.933) [-.510; .263] [-.331; 1.86] <-.369E-4>
 PHI/VG ; THE/DB -.00233 (0) (0) (.00537) (.333) (.832) [-.752; .645] <-.145E-5>
 PHI/VG ; PSI/DP -.00609 (0) (.333) (.660) [-.187; .159] [-.435; 1.21] <-.492E-4>
 THE/VG ; PHI/DA -.000742 (0) (0) (.0125) (.333) (1.19) [-.839; .672] <-.167E-5>
 THE/VG ; PSI/DP .000798 (0) (0) (.0196) (.333) (.989) [-.00243; 1.93] <.191E-4>
 PSI/VG ; PHI/DA -.0199 (0) (.333) (.799) [-.207; .179] [-.405; 1.11] <-.000208>
 PSI/VG ; THE/DB .00587 (0) (0) (.00466) (.333) (.926) [-.372; 1.98] <.333E-4>

TABLE V-5 CONTINUED
UH-IH TRANSFER FUNCTION FACTORS

CASE I26 60KT BAR ON

GUST NUMERATORS CONTINUED:

PHI/WG ;THE/DB	- .00133 (0) (0) (.00379) (.333) (.338) [.393;2.51]<-.357E-5>
PHI/WG ;PSI/DP	- .0160 (0) (.0677) (.333) [.253;.204][.297;.980]<-.145E-4>
THE/WG ;PHI/DA	.00172 (0) (0) (.0128) (.329) (.333) [.389;1.76]<.751E-5>
THE/WG ;PSI/DP	- .00397 (0) (.0158) (.333) [.455;.131][.579;2.01]<-.144E-5>
PSI/WG ;PHI/DA	.00795 (0) (.108) (.333) [.250;.201][.399;.999]<.115E-4>
PSI/WG ;THE/DB	- .00280 (0) (.00380) (.333) [.635;.310][.310;1.81]<-.112E-5>
PHI/PG ;THE/DB	- .186 (0) (.00454) (.333) (.334) (.943) [.365;1.95]<-.000339>
PHI/PG ;PSI/DP	-1.72 (.0715) (.333) (.708) [.172;.159][.456;1.22]<-.00109>
THE/PG ;PHI/DA	- .117 (0) (.00333) (.333) (.334) (.903) [.364;1.94]<-.000147>
THE/PG ;PSI/DP	.298 (-.0349) (.333) (.902) [.880;.0646][.0875;1.88]<-.458E-4>
PSI/PG ;PHI/DA	.0712 (.0149) (-.0964) (.168) (.333) (.483) [-.271;1.80]<-.895E-5>
PSI/PG ;THE/DB	- .0373 (.00453) (.333) (.359) (.814) (1.80) [-.198;1.88]<-.000104>
PHI/QG ;THE/DB	- .157 (0) (.00138) (.332) (.333) (.791) [.381;1.96]<-.735E-4>
PHI/QG ;PSI/DP	-1.12 (.0724) (.333) (1.01) [-.416;.253][-.00707;.804]<-.00114>
THE/QG ;PHI/DA	.292 (0) (.0141) (.333) (.334) (.875) [.365;1.93]<.00149>
THE/QG ;PSI/DP	- .748 (.0154) (.333) (.873) [-.473;.114][.457;1.97]<-.000170>
PSI/QG ;PHI/DA	- .0404 (.0599) (.187) (-.204) (.333) (.471) [.172;3.09]<.000139>
PSI/QG ;THE/DB	- .0376 (.00134) (.299) (.333) [.843;1.24][-.290;1.69]<-.218E-4>
PHI/RG ;THE/DB	.0499 (0) (.00598) (.333) (.363) (-1.56) [-.990;1.24]<-.865E-4>
PHI/RG ;PSI/DP	- .103 (-.0732) (.333) (1.02) [-.182;.166][.506;1.17]<-.977E-4>
THE/RG ;PHI/DA	.00597 (0) (.0199) (.333) (.370) (.779) (-3.20) (3.82) <-.000140>
THE/RG ;PSI/DP	.0246 (.0124) (-.0483) (.135) (.333) (.607) [.171;1.74]<-.121E-5>
PSI/RG ;PHI/DA	.737 (.0711) (.333) (.795) [-.205;.176][.405;1.12]<.000539>
PSI/RG ;THE/DB	- .221 (.00599) (.333) (.940) [.450;.133][.364;1.95]<-.279E-4>
XD/UG ;PHI/DA	.0130 (0) (.321) (.333) (.896) [.376;1.96][.0622;2.13]<.0216>
XD/UG ;THE/DB	- .000920 (0) (.0130) (.333) (.925) [.503;1.81][.232;1.96]<-.464E-4>
XD/UG ;PSI/DP	- .0327 (.319) (.890) [-.521;.0976][.336;1.96][.0887;2.16]<-.00158>
ZD/UG ;PHI/DA	.0259 (0) (0) (.333) (.335) [.353;2.00][.164;2.42]<.0678>
ZD/UG ;THE/DB	.000285 (0) (0) (.333) (-2.63) [-.415;.219][.388;2.05]<-.505E-4>
ZD/UG ;PSI/DP	- .0655 (0) (.336) [-.501;.0980][.328;1.95][.155;2.49]<-.00498>
YD/VG ;PHI/DA	.0584 (0) (.333) [.211;.172][.980;.850][.402;1.13]<.000529>
YD/VG ;THE/DB	- .0216 (0) (.00537) (.333) (.358) [.990;.721][.233;2.54]<-.464E-4>
YD/VG ;PSI/DP	- .114 (.0992) (.750) [.228;.167][.430;1.13][.277;2.28]<-.00158>
XD/WG ;PHI/DA	- .00454 (0) (0) (.333) (.354) [.371;1.73][.0249;3.42]<-.0189>
XD/WG ;THE/DB	- .00173 (0) (0) (.0199) (.333) [.516;1.69][.220;1.83]<-.000109>
XD/WG ;PSI/DP	.0127 (0) (.360) [.461;.131][.599;2.22][.0813;2.76]<.00296>
ZD/WG ;PHI/DA	.493 (0) (.333) [.224;.188][.396;.999][.374;1.93]<.0216>
ZD/WG ;THE/DB	- .161 (0) (.00618) (.00990) (.333) [.503;1.86][.244;2.03]<-.464E-4>
ZD/WG ;PSI/DP	-1.25 [.496;.0960][.239;.189][.402;.972][.371;2.02]<-.00158>
XD/UG ; ZD/DC	- .267 (0) (.0101) (.322) [-.478;1.91][.238;1.96][.0735;2.14]<-.0553>
YD/VG ; ZD/DC	-1.44 (0) [.728;.144][.929;.461][.311;1.15][.229;2.57]<-.0554>
PHI/UG ;THE/DB ;PSI/DP	.000385 (0) (.0726) (.333) (.333) (.942) <.292E-5>
THE/UG ;PHI/DA ;PSI/DP	.00258 (0) (.0720) (.333) (.333) (.913) <.190E-4>
PSI/UG ;PHI/DA ;THE/DB	- .000271 (0) (.0684) (.333) (.333) (.934) <-.192E-5>
PHI/VG ;THE/LB ;PSI/DP	.00102 (0) (.06605) (.333) (.333) (.846) <.577E-6>
THE/VG ;PHI/DA ;PSI/DP	.000473 (0) (.0131) (.333) (.333) (1.04) <.992E-6>
PSI/VG ;PHI/DA ;THE/DB	.00349 (0) (.00468) (.333) (.333) (.930) <.169E-5>
PHI/WG ;THE/DB ;PSI/DP	.00304 (0) (.00371) (.0670) (.333) (.333) <.840E-7>
THE/WG ;PHI/DA ;PSI/DP	- .00230 (0) (.0137) (.0756) (.333) (.333) <-.265E-6>
PSI/WG ;PHI/DA ;THE/DB	- .00147 (0) (.00396) (.112) (.333) (.333) <-.725E-7>

TABLE V-5 CONTINUED
UH-IH TRANSFER FUNCTION FACTORS

CASE I26 60KT BAR ON

GUST NUMERATORS CONCLUDED:

PHI/PG ;THE/DB ;PSI/DP	.283 (.00474) (.0716) (.333) (.333) (.933) <.100E-4>
THE/PG ;PHI/DA ;PSI/DP	.176 (.00335) (.0716) (.333) (.333) (.897) <.421E-5>
PSI/PG ;PHI/DA ;THE/DB	-.00615 (.00317) (.120) (.333) (.333) (1.35) <-.350E-6>
PHI/QG ;THE/DB ;PSI/DP	.242 (.00207) (.0721) (.333) (.333) (.795) <.319E-5>
THE/QG ;PHI/DA ;PSI/DP	-.437 (.0141) (.0719) (.333) (.333) (.868) <-.428E-4>
PSI/QG ;PHI/DA ;THE/DB	-.00859 (.0374) (.106) (.333) (.333) (-.832) <.315E-5>
PHI/RG ;THE/DB ;PSI/DP	.0165 (.00587) (.0732) (.333) (.333) (1.36) <.107E-5>
THE/RG ;PHI/DA ;PSI/DP	.0145 (.0231) (.0745) (.333) (.333) (.541) <.150E-5>
PSI/RG ;PHI/DA ;THE/DB	-.128 (.00500) (.0710) (.333) (.333) (.946) <-.480E-5>
XD/UG ;PHI/DA ;THE/DB	-.000519 (0) (.333) (.333) (.927) [.372;1.81] <-.000176>
XD/UG ;PHI/DA ;PSI/DP	-.0192 (.0720) (.319) (.333) (.889) [.0786;2.16] <-.000611>
XD/UG ;THE/DB ;PSI/DP	.00121 (.333) (.923) [.483;-114] [.359;1.96] <.185E-4>
ZD/UG ;PHI/DA ;THE/DB	.000164 (0) (0) (.333) (.333) [-.694;1.24] <.279E-4>
ZD/UG ;PHI/DA ;PSI/DP	-.0384 (0) (.0720) (.333) (.336) [.127;2.49] <-.00192>
ZD/UG ;THE/DB ;PSI/DP	-.000675 (0) (.333) [.510;-234] [.104;1.88] <-.436E-4>
YD/VG ;PHI/DA ;THE/DB	-.0101 (0) (.00500) (.333) (.333) [-.983;-923] <-.480E-5>
YD/VG ;PHI/DA ;PSI/DP	-.0609 (.333) (.771) [.205;-176] [.403;1.12] <-.000611>
YD/VG ;THE/DB ;PSI/DP	.0198 (.00611) (.101) (.333) (.894) [-.282;2.25] <.185E-4>
XD/WG ;PHI/DA ;THE/DB	-.000975 (0) (0) (.333) (.333) [.392;1.57] <-.000267>
XD/WG ;PHI/DA ;PSI/DP	.00714 (0) (.0759) (.333) (.360) [.00169;3.10] <.000625>
XD/WG ;THE/DB ;PSI/DP	.00183 (0) (.333) [-.479;-152] [.330;1.98] <.552E-4>
ZD/WG ;PHI/DA ;THE/DB	-.0905 (0) (.00468) (.333) (.333) [.375;1.93] <-.000176>
ZD/WG ;PHI/DA ;PSI/DP	-.735 (.0720) (.333) [-.224;-186] [-.395;-999] <-.000611>
ZD/WG ;THE/DB ;PSI/DP	.230 (.00610) (.333) [.495;-102] [.372;1.96] <.185E-4>
XD/UG ; ZD/DC ;PHI/DA	-.151 (0) (.322) (.333) [-.369;1.93] [.0664;2.14] <-.274>
XD/UG ; ZD/DC ;THE/DB	.0104 (0) (.0124) (.333) [.498;1.81] [.231;1.94] <.000531>
XD/UG ; ZD/DC ;PSI/DP	.379 (.320) [-.496;-108] [.335;1.95] [.0880;2.17] <.0251>
YD/VG ; ZD/DC ;PHI/DA	-.671 (0) (.333) (.848) [.648;-165] [.304;1.13] <-.00656>
YD/VG ; ZD/DC ;THE/DB	.244 (0) (.00550) (.333) [.977;-429] [.232;2.54] <.000531>
YD/VG ; ZD/DC ;PSI/DP	1.32 (.0959) [-.596;-170] [-.336;1.15] [-.271;2.28] <.0251>
XD/UG ;PHI/DA ;THE/DB ;PSI/DP	.000714 (.0718) (.333) (.333) (.924) <.526E-5>
ZD/UG ;PHI/DA ;THE/DB ;PSI/DP	-.000393 (0) (.0694) (.333) (.333) <-.303E-5>
YD/VG ;PHI/DA ;THE/DB ;PSI/DP	.0106 (.00488) (.333) (.333) (.914) <.526E-5>
XD/WG ;PHI/DA ;THE/DB ;PSI/DP	.00111 (0) (.0781) (.333) (.333) <.967E-5>
ZD/WG ;PHI/DA ;THE/DB ;PSI/DP	.135 (.00488) (.0720) (.333) (.333) <.526E-5>
XD/UG ; ZD/DC ;PHI/DA ;THE/DB	.00585 (0) (.333) (.333) [.366;1.81] <.00212>
YD/VG ; ZD/DC ;PHI/DA ;THE/DB	.114 (0) (.00504) (.333) (.333) (.867) <.556E-4>
YD/VG ; ZD/DC ;PHI/DA ;PSI/DP	.703 (.333) [.511;-165] [.315;1.12] <.00811>
XD/WG ; ZD/DC ;PHI/DA ;THE/DB	.0210 (0) (.333) (.333) [.394;1.51] <.00530>
XD/UG ; ZD/DC ;PHI/DA ;THE/DB ;PSI/DP	-.00810 (.0722) (.333) (.333) <-.650E-4>
YD/VG ; ZD/DC ;PHI/DA ;THE/DB ;PSI/DP	-.121 (.00484) (.333) (.333) <-.650E-4>
XD/WG ; ZD/DC ;PHI/DA ;THE/DB ;PSI/DP	-.0229 (.0751) (.333) (.333) <-.000191>

TABLE V-5 CONTINUED
UH-IH TRANSFER FUNCTION FACTORS

CASE 127 80KT BAR OFF

DENOMINATOR: (0) (-.0523) (1.56) [.0531; .261] [.546; 1.11] [.333; 2.31] < .0363 >

CONTROL NUMERATORS:

PHI/DA .564 (0) [-.0408; .319] [.766; 1.06] [.351; 2.36] < .359 >
 THE/DB -.172 (0) (.00934) (.0514) [.987; 1.11] [.333; 2.30] < -.000545 >
 PSI/DP -1.65 (1.56) [-.0499; .265] [.233; .295] [.561; 1.09] < -.0187 >

PHI/DB .0624 (0) (-.0675) (.0871) [.288; 2.26] [.600; 3.16] < -.0187 >
 THE/DA .114 (0) (1.02) [.625; .0308] [.328; 2.37] < .000621 >

PHI/DA ; THE/DB -.0974 (0) (.00884) (1.06) [.353; 2.36] < -.00506 >
 PHI/DA ; PSI/DP -.966 (.0960) [-.0310; .316] [.754; 1.07] < -.0106 >
 THE/DB ; PSI/DP .286 (.00931) [.0964; .294] [.992; 1.11] < .000283 >

PHI/DB ; PSI/DP -.139 (-.0622) [.990; .0884] [.491; 2.59] < .000454 >
 PHI/DP ; THE/DB -.0810 (0) (.00930) (.934) (-1.03) (1.59) < .00115 >
 PHI/DC ; THE/DB .00869 (0) (.00843) (-4.70) [.620; 2.41] < -.00200 >

THE/DA ; PSI/DP -.195 (-.0287) (1.02) [.125; .258] < -.000381 >
 THE/DP ; PHI/DA -.0185 (0) (.0280) (-1.13) (1.26) (2.12) < .00157 >
 THE/DC ; PHI/DA .0349 (0) (.0203) [.278; 2.14] < .00324 >

PSI/DA ; THE/DB -.0136 (.00884) (1.03) (2.17) [-.241; 2.09] < -.00117 >
 PSI/DB ; PHI/DA .0380 (.0720) (-.136) (.214) [.156; 2.41] < -.000461 >
 XD/DB ; PHI/DA .537 (0) (1.05) [.352; 2.35] [.0671; 2.43] < 18.4 >

YD/DA ; THE/DB -.152 (.00884) (1.06) [.311; 2.28] [.0162; 4.63] < -.158 >
 ZD/DB ; PHI/DA 2.19 (0) (.0274) [.360; 2.36] [.147; 2.52] < 2.12 >
 XD/DC ; PHI/DA .0974 (0) (-2.15) [.314; 1.90] [.490; 2.59] < -5.08 >

YD/DP ; THE/DB -.383 (.00931) (.872) (2.05) (-2.58) [.479; 1.53] < .0382 >
 ZD/DC ; PHI/DA -7.04 (0) (.283) [.277; .677] [.344; 2.34] < -5.01 >

PHI/DA ; THE/DB ; PSI/DP .168 (.00892) (.0959) (1.05) < .000151 >
 PHI/DC ; THE/DB ; PSI/DP .0646 (.00846) (.0931) < .509E-4 >
 THE/DC ; PHI/DA ; PSI/DP -.0531 (.0211) (.0973) < -.000109 >

PSI/DC ; PHI/DA ; THE/DB -.0193 (.00835) (.116) (2.08) < -.389E-4 >
 XD/DB ; PHI/DA ; PSI/DP -.918 (.0958) (1.04) [.0676; 2.44] < -.545 >
 YD/DA ; THE/DB ; PSI/DP .282 (.00894) (1.05) [-.00547; 4.31] < .0494 >

ZD/DC ; PHI/DA ; THE/DB 1.21 (0) (.00773) [.348; 2.34] < .0515 >
 ZD/DC ; PHI/DA ; PSI/DP 12.1 (.0961) (.266) [.263; .708] < .154 >
 XD/DC ; PHI/DA ; THE/DB -.0182 (0) (1.20) [.406; 2.08] < -.0948 >

XD/DC ; PHI/DA ; PSI/DP -.159 (.0974) (-2.10) [.442; 2.25] < .165 >
 YD/DP ; PHI/DA ; THE/DB -.145 (.00893) (1.05) (3.83) (-3.93) < .0204 >
 ZD/DB ; PHI/DA ; PSI/DP -3.74 (.0277) (.0960) [.146; 2.52] < -.0634 >

ZD/DC ; PHI/DA ; THE/DB ; PSI/DP -2.11 (.00766) (.0964) < -.00156 >
 XD/DC ; PHI/DA ; THE/DB ; PSI/DP .0266 (.0985) (1.24) < .00325 >

TABLE V-5 CONTINUED
UH-IH TRANSFER FUNCTION FACTORS

CASE 127 80KT BAR ON

DENOMINATOR: (0) (.0101) (.788) [.209;-.177][.514;1.22][.414;2.08][.268;2.25]<.00809>

CONTROL NUMERATORS:

PHI/DA .564 (0) (.333) (.766) [.213;-.178][.436;1.25][.350;2.36]<.0399>
 THE/DB -.172 (0) (.333) (1.05) [.992;.00964][.449;2.05][.271;2.25]<-.000119>
 PSI/DP -1.65 (.781) [.651;-.0914][.225;-.178][.496;1.22][.339;2.02]<-.00207>

PHI/DB .0624 (0) (-.0670) (.0870) (.333) (.336) [.290;2.26][.602;3.14]<-.00206>
 THE/DA .114 (0) (-.0232) (-.0657) (-.282) (-.333) (1.02) [.330;2.37]<.937E-4>

PHI/DA ;THE/DB -.0974 (0) (.00884) (.333) (.333) (1.06) [.353;2.36]<-.000563>
 PHI/DA ;PSI/DP -.966 (.0959) (.333) (-.757) [.215;-.177][.430;1.27]<-.00117>
 THE/DB ;PSI/DP .286 (.00934) (.333) (1.05) [.655;-.0932][.361;1.97]<.314E-4>

PHI/DB ;PSI/DP -.139 (-.0621) (.333) (.334) [.990;.0883][.491;2.59]<.504E-4>
 PHI/DP ;THE/DB -.0810 (0) (.00933) (.333) (.401) (.876) (-.927) (1.47) <.000121>
 PHI/DC ;THE/DB .00869 (0) (.00843) (.333) (-.339) (-4.65) [.612;2.40]<-.000221>

THE/DA ;PSI/DP -.195 (.0287) (.333) (.333) (1.02) [.125;-.258]<-.423E-4>
 THE/DP ;PHI/DA -.0185 (0) (.0289) (.333) (.384) (-.996) (1.40) (1.80) <.000171>
 THE/DC ;PHI/DA .0349 (0) (.0203) (.330) (.333) [.284;2.16]<.000361>

PSI/DA ;THE/DB -.0136 (.00884) (.333) (.333) (1.03) (2.17) [-.241;2.09]<-.000130>
 PSI/DB ;PHI/DA .0380 (.0720) (-.136) (.214) (.333) (-.333) [.156;2.41]<-.512E-4>
 XD/DB ;PHI/DA .537 (0) (.333) (.333) (1.05) [.352;2.35][.0671;2.43]<2.05>

YD/DA ;THE/DB -.152 (.00884) (.333) (.333) (1.06) [.311;2.28][.0162;4.63]<-.0176>
 ZD/DB ;PHI/DA 2.19 (0) (-.0274) (.333) (.333) [-.360;2.36][.147;2.52]<.235>
 XD/DC ;PHI/DA .0974 (0) (.333) (.352) (-1.97) [-.293;1.94][.466;2.58]<-.567>

YD/DP ;THE/DB -.383 (.00934) (-.0766) (-.333) (1.02) (2.61) (-2.78) [.240;2.50]<.00425>
 ZD/DC ;PHI/DA -7.04 (0) (.333) [-.603;-.172][.326;1.21][.343;2.34]<-.556>

PHI/DA ;THE/DB ;PSI/DP .168 (.00892) (-.0959) (.333) (.333) (1.05) <.168E-4>
 PHI/DC ;THE/DB ;PSI/DP .0646 (.00846) (-.0931) (.333) (.333) <.566E-5>
 THE/DC ;PHI/DA ;PSI/DP -.0531 (.0211) (-.0973) (.333) (.333) <-.121E-4>

PSI/DC ;PHI/DA ;THE/DB -.0193 (.00835) (.116) (.333) (.333) (2.08) <-.432E-5>
 XD/DB ;PHI/DA ;PSI/DP -.918 (.0958) (-.333) (.333) (1.04) [-.0676;2.44]<-.0605>
 YD/DA ;THE/DB ;PSI/DP .282 (.00894) (.333) (.333) (1.05) [-.00547;4.31]<.00549>

ZD/DC ;PHI/DA ;THE/DB 1.21 (0) (.00773) (.333) (.333) [.348;2.34]<.00572>
 ZD/DC ;PHI/DA ;PSI/DP 12.1 (-.0962) (.333) [.618;-.173][.311;1.22]<.0172>
 XD/DC ;PHI/DA ;THE/DB -.0182 (0) (.333) (.333) (1.20) [.406;2.08]<-.0105>

XD/DC ;PHI/DA ;PSI/DP -.159 (.0974) (.333) (.357) (-1.92) [.394;2.27]<.0183>
 YD/DP ;PHI/DA ;THE/DB -.145 (.00893) (-.333) (.333) (1.05) (3.83) (-3.93) <.00227>
 ZD/DB ;PHI/DA ;PSI/DP -3.74 (.0277) (-.0960) (.333) (.333) [.146;2.52]<-.00704>

ZD/DC ;PHI/DA ;THE/DB ;PSI/DP -2.11 (.00766) (-.0964) (-.333) (.333) <-.000173>
 XD/DC ;PHI/DA ;THE/DB ;PSI/DP .0266 (.0985) (-.333) (-.333) (1.24) <.000361>

TABLE V-5 CONTINUED
UH-IH TRANSFER FUNCTION FACTORS

CASE I28 I00KT BAR OFF

DENOMINATOR: (0) (.0507) (1.56) [.0896; .239] [.477; 1.35] [.333; 2.67] <-.0583>

CONTROL NUMERATORS:

PHI/DA .578 (0) [.0359; .286] [.654; 1.32] [.347; 2.73] <.618>
THE/DB -.171 (0) (.0136) (.0532) [.980; 1.15] [.334; 2.67] <-.00116>
PSI/DP -1.82 (1.56) [.0430; .258] [.232; .271] [.489; 1.34] <-.0247>

PHI/DB .104 (0) [.256; .0789] [.298; 2.56] [.461; 3.15] <.0422>
THE/DA .108 (0) (1.13) [.466; .0323] [.325; 2.74] <.000962>

PHI/DA ; THE/DB -.0993 (0) (.0144) (1.21) [.349; 2.73] <-.0130>
PHI/DA ; PSI/DP -1.10 (.121) [.0421; .285] [.646; 1.33] <-.0189>
THE/DB ; PSI/DP .315 (.0136) [.148; .291] [.987; 1.14] <.000474>

PHI/DB ; PSI/DP -.236 (.117) [.254; .0812] [.394; 2.66] <-.00129>
PHI/DP ; THE/DB -.0911 (0) (.0136) (.966) (-1.06) (1.87) <.00237>
PHI/DC ; THE/DB .0216 (0) (.0150) (-2.53) [.541; 2.60] <-.00553>

THE/DA ; PSI/DP -.205 (.0401) (1.14) [.126; .264] <-.000656>
THE/DP ; PHI/DA -.0196 (0) (.0385) (-1.28) [.954; 1.87] <.00339>
THE/DC ; PHI/DA -.0105 (0) (.0268) (-3.66) [.278; 2.70] <.00753>

PSI/DA ; THE/DB -.0141 (.0144) (1.17) (2.17) [-.235; 2.16] <-.00240>
PSI/DB ; PHI/DA .0405 (.221) [.0803; .0157] [.212; 2.64] <.154E-4>
XD/DB ; PHI/DA .478 (0) (1.28) [.0712; 2.53] [.346; 2.72] <28.9>

YD/DA ; THE/DB -.155 (.0144) (1.22) [.289; 2.59] [.0318; 4.69] <-.405>
ZD/DB ; PHI/DA 2.91 (0) (.0421) [-.158; 2.64] [-.353; 2.73] <6.38>
XD/DC ; PHI/DA .255 (0) (-1.19) [-.308; 1.98] [.406; 2.71] <-8.82>

YD/DP ; THE/DB -.419 (.0136) (.873) (3.06) (-3.41) [.565; 1.24] <.0801>
ZD/DC ; PHI/DA -7.61 (0) (.232) [.299; .854] [.341; 2.71] <-9.46>

PHI/DA ; THE/DB ; PSI/DP .190 (.0144) (.120) (1.20) <.000396>
PHI/DC ; THE/DB ; PSI/DP -.0212 (.0152) (.118) (-3.97) <.000151>
THE/DC ; PHI/DA ; PSI/DP .0244 (.0276) (.121) (-3.11) <-.000256>

PSI/DC ; PHI/DA ; THE/DB -.0218 (.0144) (.142) (2.18) <-.975E-4>
XD/DB ; PHI/DA ; PSI/DP -.902 (.120) (1.26) [.0726; 2.54] <-.884>
YD/DA ; THE/DB ; PSI/DP .319 (.0144) (1.21) [-.00549; 4.29] <.102>

ZD/DC ; PHI/DA ; THE/DB 1.36 (0) (.0120) [.345; 2.72] <.121>
ZD/DC ; PHI/DA ; PSI/DP 14.4 (.121) (.225) [.287; .879] <.303>
XD/DC ; PHI/DA ; THE/DB -.0352 (0) (.731) [.387; 2.55] <-.167>

XD/DC ; PHI/DA ; PSI/DP -.468 (.122) (-1.19) [.365; 2.07] <.290>
YD/DP ; PHI/DA ; THE/DB -.160 (.0144) (1.20) (4.87) (-4.98) <.0669>
ZD/DB ; PHI/DA ; PSI/DP -5.52 (.0421) (.121) [.156; 2.64] <-.195>

ZD/DC ; PHI/DA ; THE/DB ; PSI/DP -2.62 (.0117) (.121) <-.00373>
XD/DC ; PHI/DA ; THE/DB ; PSI/DP .0609 (.123) (.783) <.00587>

TABLE V-5 CONTINUED
UH-IH TRANSFER FUNCTION FACTORS

CASE 128 100KT BAR ON

DENOMINATOR: (0) (.0106) (.718) [-.220; .175] [.541; 1.42] [.318; 2.15] [.324; 2.58] <-.0145>

CONTROL NUMERATORS:

PHI/DA .578 (0) (.333) (-.699) [.223; .176] [-.439; 1.49] [.347; 2.73] <.0686>
THE/DB -.171 (0) (.00983) (.0150) (.333) (1.20) [.369; 2.09] [.322; 2.57] <-.000293>
PSI/DP -1.82 (.715) [.809; .0887] [-.232; .176] [.525; 1.42] [-.302; 2.07] <-.00275>

PHI/DB .104 (0) (.333) (-.335) [-.258; .0790] [.299; 2.56] [.462; 3.13] <.00468>
THE/DA .108 (0) (.277) (.333) (1.13) [-.954; .0450] [-.327; 2.74] <.000172>

PHI/DA ; THE/DB -.0993 (0) (.0144) (.333) (-.333) (1.21) [-.349; 2.73] <-.00144>
PHI/DA ; PSI/DP -1.10 (.120) (.333) (-.693) [.224; .175] [.435; 1.50] <-.00210>
THE/DB ; PSI/DP .315 (.0134) (.333) (1.19) [.821; .0887] [-.334; 1.99] <.527E-4>

PHI/DB ; PSI/DP -.236 (.117) (.333) (.334) [.254; .0810] [-.394; 2.66] <-.000143>
PHI/DP ; THE/DB -.0911 (0) (.0135) (.333) (-.419) (-.859) (-.914) (1.75) <.000237>
PHI/DC ; THE/DB .0216 (0) (-.0150) (.333) (-.338) (-2.48) [-.533; 2.59] <-.000608>

THE/DA ; PSI/DP -.205 (.0401) (.333) (.333) (1.14) [-.126; .264] <-.728E-4>
THE/DP ; PHI/DA -.0196 (0) (-.0400) (.333) (-.381) (-1.11) [-.917; 1.82] <.000365>
THE/DC ; PHI/DA -.0105 (0) (-.0267) (-.331) (.333) (-3.69) [-.284; 2.71] <.000839>

PSI/DA ; THE/DB -.0141 (.0144) (.333) (-.333) (1.17) (2.17) [-.235; 2.16] <-.000266>
PSI/DB ; PHI/DA .0405 (.221) (.333) (.333) [.0803; .0157] [.212; 2.64] <.171E-5>
XD/DB ; PHI/DA .478 (0) (.333) (.333) (1.28) [.0712; 2.53] [.346; 2.72] <3.21>

YD/DA ; THE/DB -.155 (.0144) (.333) (-.333) (1.22) [.289; 2.59] [.0318; 4.69] <-.0450>
ZD/DB ; PHI/DA 2.91 (0) (-.0421) (.333) (.333) [-.158; 2.64] [.353; 2.73] <.709>
XD/DC ; PHI/DA .255 (0) (.333) (.346) (-1.07) [-.271; 2.05] [.400; 2.72] <-.985>

YD/DP ; THE/DB -.419 (.0134) (.0586) (.333) (1.15) (3.43) (-3.58) [-.249; 2.39] <.00890>
ZD/DC ; PHI/DA -7.61 (0) (.333) [-.694; .179] [.312; 1.33] [-.341; 2.71] <-1.05>

PHI/DA ; THE/DB ; PSI/DP .190 (.0144) (.120) (.333) (.333) (1.20) <.440E-4>
PHI/DC ; THE/DB ; PSI/DP -.0212 (.0152) (-.118) (.333) (.333) (-3.97) <.168E-4>
THE/DC ; PHI/DA ; PSI/DP .0244 (.0276) (.121) (.333) (.333) (-3.11) <-.284E-4>

PSI/DC ; PHI/DA ; THE/DB -.0218 (.0144) (-.142) (.333) (.333) (2.18) <-.108E-4>
XD/DB ; PHI/DA ; PSI/DP -.902 (.120) (.333) (.333) (1.26) [-.0726; 2.54] <-.0982>
YD/DA ; THE/DB ; PSI/DP .319 (.0144) (.333) (.333) (1.21) [-.00550; 4.29] <.0114>

ZD/DC ; PHI/DA ; THE/DB 1.36 (0) (.0120) (.333) (.333) [-.345; 2.72] <.0134>
ZD/DC ; PHI/DA ; PSI/DP 14.4 (.121) (.333) [.704; .180] [-.302; 1.34] <.0337>
XD/DC ; PHI/DA ; THE/DB -.0352 (0) (.333) (.333) (.731) [-.387; 2.55] <-.0186>

XD/DC ; PHI/DA ; PSI/DP -.468 (.122) (.333) (.350) (-1.06) [-.318; 2.14] <.0323>
YD/DP ; PHI/DA ; THE/DB -.160 (.0144) (.333) (.333) (1.20) (4.87) (-4.98) <.00743>
ZD/DB ; PHI/DA ; PSI/DP -5.52 (.0421) (.121) (.333) (.333) [-.156; 2.64] <-.0217>

ZD/DC ; PHI/DA ; THE/DB ; PSI/DP -2.62 (.0117) (.121) (.333) (.333) <-.000414>
XD/DC ; PHI/DA ; THE/DB ; PSI/DP .0609 (.121) (.333) (.333) (.783) <.000652>

TABLE V-5 CONTINUED
UH-IH TRANSFER FUNCTION FACTORS

CASE I29 I20KT BAR OFF

DENOMINATOR: (0) (-.0502) (1.48) [.116; .215] [.440; 1.60] [.329; 2.99] <.0793>

CONTROL NUMERATORS:

PHI/DA .591 (0) [.0821; .253] [.566; 1.62] [.344; 3.07] <.935>
THE/DB -.172 (0) (-.0196) (-.0568) [.997; 1.16] [.330; 2.99] <-.00231>
PSI/DP -1.99 (1.49) [.236; .187] [.0976; .331] [.450; 1.61] <-.0293>

PHI/DB .163 (0) [.263; .103] [.319; 2.80] [.362; 3.24] <.141>
THE/DA .0948 (0) (1.29) [.413; .0345] [.316; 3.09] <.00138>

PHI/DA ; THE/DB -.102 (0) (.0221) (1.39) [.345; 3.07] <-.0297>
PHI/DA ; PSI/DP -1.23 (.146) [.0882; .252] [.561; 1.62] <-.0300>
THE/DB ; PSI/DP .343 (.0185) (1.11) (1.22) [.206; .280] <.000671>

PHI/DB ; PSI/DP -.375 (.143) [.262; .103] [.334; 2.79] <-.00446>
PHI/DP ; THE/DB -.107 (0) (.0184) (.956) (-.984) (2.10) <.00388>
PHI/DC ; THE/DB .0435 (0) (.0236) (-1.57) [.488; 2.77] <-.0124>

THE/DA ; PSI/DP -.199 (.0458) (1.31) [.108; .379] <-.00171>
THE/DP ; PHI/DA -.0113 (0) (.0444) (-3.33) [.985; 2.54] <.0108>
THE/DC ; PHI/DA -.0240 (0) (.0346) (-1.93) [.299; 3.12] <.0156>

PSI/DA ; THE/DB -.0155 (.0221) (1.36) (2.07) [-.288; 2.18] <-.00457>
PSI/DB ; PHI/DA .0331 (.290) [.178; .0692] [.297; 2.86] <.000375>
XD/DB ; PHI/DA .368 (0) (1.72) [.0592; 2.69] [.344; 3.06] <.43.0>

YD/DA ; THE/DB -.159 (.0221) (1.40) [.250; 2.84] [.0615; 4.84] <-.926>
ZD/DB ; PHI/DA 3.64 (0) (.0547) [.163; 2.80] [.345; 3.08] <14.8>
XD/DC ; PHI/DA .475 (0) (-.818) [.298; 2.01] [.378; 2.97] <-13.8>

YD/DP ; THE/DB -.461 (.0185) (.867) (3.96) (-4.19) [.668; 1.05] <.136>
ZD/DC ; PHI/DA -8.07 (0) (.200) [.297; 1.04] [.338; 3.04] <-16.0>

PHI/DA ; THE/DB ; PSI/DP .213 (.0220) (.146) (1.38) <.000947>
PHI/DC ; THE/DB ; PSI/DP -.0587 (.0241) (.144) (-1.81) <.000368>
THE/DC ; PHI/DA ; PSI/DP .0535 (.0357) (.147) (-2.05) <-.000577>

PSI/DC ; PHI/DA ; THE/DB -.0307 (.0224) (-.168) (1.92) <-.000222>
XD/DB ; PHI/DA ; PSI/DP -.758 (.145) (1.70) [.0648; 2.71] <-1.37>
YD/DA ; THE/DB ; PSI/DP .359 (.0221) (1.39) [-.00829; 4.29] <.202>

ZD/DC ; PHI/DA ; THE/DB 1.54 (0) (.0183) [.341; 3.05] <.263>
ZD/DC ; PHI/DA ; PSI/DP 16.8 (.145) (.193) [.286; 1.08] <.551>
XD/DC ; PHI/DA ; THE/DB -.0672 (0) (.490) [.369; 2.90] <-.276>

XD/DC ; PHI/DA ; PSI/DP -.944 (.148) (-.854) [.338; 2.05] <.499>
YD/DP ; PHI/DA ; THE/DB -.175 (.0221) (1.38) (5.94) (-6.07) <.192>
ZD/DB ; PHI/DA ; PSI/DP -7.57 (.0545) (.146) [.160; 2.80] <-.471>

ZD/DC ; PHI/DA ; THE/DB ; PSI/DP -3.24 (.0176) (.146) <-.00834>
XD/DC ; PHI/DA ; THE/DB ; PSI/DP .131 (.150) (.546) <.0107>

TABLE V-5 CONTINUED
UH-IH TRANSFER FUNCTION FACTORS

CASE I29 I20KT BAR ON

DENOMINATOR: (0) (.0114) (.654) [-.232;-.167][-.537;1.64][-.276;2.21][-.326;2.92]<.0235>

CONTROL NUMERATORS:

PHI/DA .591 (0) (.333) (.641) [.234;.168][.422;1.76][.344;3.07]<.104>
 THE/DB -.172 (0) (.0105) (.0226) (.333) (1.38) [-.329;2.09][.328;2.92]<-.000696>
 PSI/DP -1.99 (.656)[- .989;.0842][.255;.169][.519;1.63][.268;2.15]<-.00325>

PHI/DB .163 (0) (.333) (.335) [-.264;.103][-.319;2.80][.362;3.23]<.0157>
 THE/DA .0948 (0) (.253) (.333) (1.29) [-.935;.0575][.320;3.08]<.000323>

PHI/DA ;THE/DB -.102 (0) (.0221) (.333) (.333) (1.39) [-.345;3.07]<-.00330>
 PHI/DA ;PSI/DP -1.23 (.146) (.333) (.638) [-.235;.167][.420;1.77]<-.00333>
 THE/DB ;PSI/DP .343 (.0166) (.0685) (.103) (.333) (1.37) [-.306;2.02]<.746E-4>

PHI/DB ;PSI/DP -.375 (.143) (.333) (.334) [-.263;.103][.333;2.79]<-.000496>
 PHI/DP ;THE/DB -.107 (0) (.0177) (.333) (.497) (.709) (-.775) (1.98) <.000340>
 PHI/DC ;THE/DB .0435 (0) (.0237) (.333) (.338) (-1.53) [-.479;2.77]<-.00136>

THE/DA ;PSI/DP -.199 (.0458) (.333) (.333) (1.31) [-.108;.379]<-.000190>
 THE/DP ;PHI/DA -.0113 (0) (.0455) (.333) (.362) (-3.05) [-.946;2.48]<.00116>
 THE/DC ;PHI/DA -.0240 (0) (.0345) (.331) (.333) (-1.96) [-.304;3.11]<.00174>

PSI/DA ;THE/DB -.0155 (.0221) (.333) (.333) (1.36) (2.07) [-.288;2.18]<-.000508>
 PSI/DB ;PHI/DA .0331 (.290) (.333) (.333) [-.178;.0692][.297;2.86]<.417E-4>
 XD/DB ;PHI/DA .368 (0) (.333) (.333) (1.72) [-.0592;2.69][.344;3.06]<.4.77>

YD/DA ;THE/DB -.159 (.0221) (.333) (.333) (1.40) [-.250;2.84][.0615;4.84]<-.103>
 ZD/DB ;PHI/DA 3.64 (0) (.0547) (.333) (.333) [-.163;2.80][.345;3.08]<1.64>
 XD/DC ;PHI/DA .475 (0) (.333) (.339) (-.724) [-.260;2.12][.377;2.98]<-1.55>

YD/DP ;THE/DB -.461 (.0165) (.0458) (.333) (1.31) (4.22) (-4.34) [-.245;2.32]<.0151>
 ZD/DC ;PHI/DA -8.07 (0) (.333) [-.769;.182][.295;1.47][.338;3.04]<-1.78>

PHI/DA ;THE/DB ;PSI/DP .213 (.0220) (.146) (.333) (.333) (1.38) <.000105>
 PHI/DC ;THE/DB ;PSI/DP -.0587 (.0241) (.144) (.333) (.333) (-1.81) <.409E-4>
 THE/DC ;PHI/DA ;PSI/DP .0535 (.0357) (.147) (.333) (.333) (-2.05) <-.641E-4>

PSI/DC ;PHI/DA ;THE/DB -.0307 (.0224) (.168) (.333) (.333) (1.92) <-.247E-4>
 XD/DB ;PHI/DA ;PSI/DP -.758 (.145) (.333) (.333) (1.70) [-.0648;2.71]<-.153>
 YD/DA ;THE/DB ;PSI/DP .359 (.0221) (.333) (.333) (1.39) [-.00829;4.29]<.0225>

ZD/DC ;PHI/DA ;THE/DB 1.54 (0) (.0183) (.333) (.333) [-.341;3.05]<.0292>
 ZD/DC ;PHI/DA ;PSI/DP 16.8 (.146) (.333) [-.787;.183][.286;1.50]<.0612>
 XD/DC ;PHI/DA ;THE/DB -.0672 (0) (.333) (.333) (.490) [-.369;2.90]<-.0307>

XD/DC ;PHI/DA ;PSI/DP -.944 (.148) (.333) (.344) (-.748) [-.294;2.15]<.0554>
 YD/DP ;PHI/DA ;THE/DB -.175 (.0221) (.333) (.333) (1.38) (5.94) (-6.07) <.0213>
 ZD/DB ;PHI/DA ;PSI/DP -7.57 (.0545) (.146) (.333) (.333) [-.160;2.80]<-.0524>

ZD/DC ;PHI/DA ;THE/DB ;PSI/DP -3.24 (.0176) (.146) (.333) (.333) <-.000926>
 XD/DC ;PHI/DA ;THE/DB ;PSI/DP .131 (.150) (.333) (.333) (.546) <.00119>

TABLE V-5 CONTINUED
UH-IH TRANSFER FUNCTION FACTORS

CASE 130 130KT BAR OFF

DENOMINATOR: (0) (.0527) (1.41) [.131; .203] [.428; 1.72] [.329; 3.13] <.0886>

CONTROL NUMERATORS:

PHI/DA .602 (0) [.0977; .241] [.536; 1.74] [.345; 3.23] <1.11>
 THE/DB -.176 (0) (.0240) (.0597) (.966) (1.34) [.329; 3.13] <-.00322>
 PSI/DP -2.04 (1.44) [.280; .165] [.0869; .346] [.437; 1.72] <-.0284>

PHI/DB .194 (0) [.317; .0930] [.340; 2.95] [.318; 3.25] <.155>
 THE/DA .0902 (0) (1.36) [.444; .0372] [.311; 3.24] <.00178>

PHI/DA ; THE/DB -.107 (0) (.0268) (1.46) [.344; 3.23] <-.0435>
 PHI/DA ; PSI/DP -1.29 (.159) [.103; .240] [.533; 1.75] <-.0362>
 THE/DB ; PSI/DP .359 (.0230) (.949) (1.38) [.239; .271] <.000796>

PHI/DB ; PSI/DP -.438 (.157) [.317; .0936] [.316; 2.89] <-.00500>
 PHI/DP ; THE/DB -.116 (0) (.0229) (.898) (-.921) (2.22) <.00487>
 PHI/DC ; THE/DB .0577 (0) (.0283) (-1.29) [.474; 2.83] <-.0169>

THE/DA ; PSI/DP -.195 (.0473) (1.39) [.0999; .421] <-.00226>
 THE/DP ; PHI/DA -.0106 (0) (.0461) (-4.06) [.986; 2.80] <.0155>
 THE/DC ; PHI/DA -.0299 (0) (.0390) (-1.65) [.299; 3.30] <.0210>

PSI/DA ; THE/DB -.0162 (.0268) (1.44) (2.03) [-.340; 2.20] <-.00618>
 PSI/DB ; PHI/DA .0201 (.399) [.162; .0602] [.414; 3.15] <.000288>
 XD/DB ; PHI/DA .300 (0) (2.09) [.0464; 2.81] [.347; 3.23] <51.7>

YD/DA ; THE/DB -.167 (.0268) (1.46) [.225; 2.93] [.0811; 4.92] <-1.36>
 ZD/DB ; PHI/DA 4.01 (0) (.0610) [.165; 2.90] [.344; 3.23] <21.5>
 XD/DC ; PHI/DA .604 (0) (-.702) [.295; 2.01] [.373; 3.09] <-16.4>

YD/DP ; THE/DB -.484 (.0230) (.830) (4.41) (-4.59) [.731; .966] <.175>
 ZD/DC ; PHI/DA -8.35 (0) (.196) [-.297; 1.10] [.337; 3.19] <-20.3>

PHI/DA ; THE/DB ; PSI/DP .229 (.0268) (.159) (1.45) <.00141>
 PHI/DC ; THE/DB ; PSI/DP -.0808 (.0287) (.157) (-1.41) <.000512>
 THE/DC ; PHI/DA ; PSI/DP .0679 (.0399) (.161) (-1.83) <-.000798>

PSI/DC ; PHI/DA ; THE/DB -.0396 (.0270) (.181) (1.69) <-.000328>
 XD/DB ; PHI/DA ; PSI/DP -.636 (.158) (2.08) [.0534; 2.83] <-1.68>
 YD/DA ; THE/DB ; PSI/DP .385 (.0269) (1.45) [-.0101; 4.29] <.277>

ZD/DC ; PHI/DA ; THE/DB 1.68 (0) (.0226) [.340; 3.20] <.387>
 ZD/DC ; PHI/DA ; PSI/DP 17.9 (.156) (.189) [.285; 1.17] <.716>
 XD/DC ; PHI/DA ; THE/DB -.0921 (0) (.398) [.364; 3.03] <-.337>

XD/DC ; PHI/DA ; PSI/DP -1.22 (.161) (-.746) [.332; 2.04] <.611>
 YD/DP ; PHI/DA ; THE/DB -.184 (.0268) (1.44) (6.52) (-6.66) <.309>
 ZD/DB ; PHI/DA ; PSI/DP -8.58 (.0608) (.159) [.161; 2.90] <-.696>

ZD/DC ; PHI/DA ; THE/DB ; PSI/DP -3.62 (.0217) (.159) <-.0125>
 XD/DC ; PHI/DA ; THE/DB ; PSI/DP .183 (.164) (-.443) <.0133>

TABLE V-5 CONTINUED
UH-IH TRANSFER FUNCTION FACTORS

CASE 130 130KT BAR ON

DENOMINATOR: (0) (.0119) (.633) [-.242; .163] [.524; 1.74] [.257; 2.25] [.328; 3.07] <-.0289>

CONTROL NUMERATORS:

PHI/DA .602 (0) (.333) (.622) [-.242; -.164] [.411; 1.88] [.345; 3.23] <.123>
THE/DB -1.176 (0) (.0112) (.0272) (.333) (1.44) [.308; 2.10] [.329; 3.07] <-.00106>
PSI/DP -2.04 (.0483) (.128) (.638) [-.271; -.166] [.507; 1.72] [.253; 2.20] <-.00316>

PHI/DB .194 (0) (.333) (.334) [-.318; -.0930] [.338; 2.95] [.320; 3.25] <.0172>
THE/DA .0901 (0) (.229) (.333) (1.36) [-.980; -.0689] [.315; 3.24] <.000467>

PHI/DA ;THE/DB -1.107 (0) (.0268) (.333) (.333) (1.46) [-.344; 3.23] <-.00483>
PHI/DA ;PSI/DP -1.29 (.159) (.333) (.620) [.244; .163] [.410; 1.89] <-.00402>
THE/DB ;PSI/DP .359 (.0191) (.0480) (.136) (.333) (1.44) [.288; 2.03] <.885E-4>

PHI/DB ;PSI/DP -1.438 (.157) (.333) (.334) [-.318; .0934] [.316; 2.89] <-.000556>
PHI/DP ;THE/DB -1.116 (0) (.0217) (.333) (-.656) (2.09) [.956; .575] <.000379>
PHI/DC ;THE/DB .0577 (0) (.0283) (.333) (.338) (-1.25) [.464; 2.84] <-.00184>

THE/DA ;PSI/DP -1.195 (.0473) (.333) (.333) (1.39) [-.0999; .421] <-.000252>
THE/DP ;PHI/DA -1.0106 (0) (.0471) (.333) (.358) (-3.73) [.943; 2.74] <.00166>
THE/DC ;PHI/DA -1.0299 (0) (.0389) (.332) (.333) (-1.69) [-.305; 3.29] <.00235>

PSI/DA ;THE/DB -1.0162 (.0268) (.333) (.333) (1.44) (2.03) [-.340; 2.20] <-.000686>
PSI/DB ;PHI/DA .0201 (.333) (.333) (.399) [-.162; .0602] [.414; 3.15] <.320E-4>
XD/DB ;PHI/DA .300 (0) (.333) (.333) (2.09) [-.0464; 2.81] [.347; 3.23] <.5.74>

YD/DA ;THE/DB -1.167 (.0268) (.333) (.333) (1.46) [.225; 2.93] [.0811; 4.92] <-.151>
ZD/DB ;PHI/DA 4.01 (0) (.0610) (.333) (.333) [-.165; 2.90] [.344; 3.23] <2.38>
XD/DC ;PHI/DA .604 (0) (.333) (.335) (-.617) [-.257; 2.14] [.372; 3.10] <-1.83>

YD/DP ;THE/DB -1.484 (.0187) (.0404) (.333) (1.37) (4.64) (-4.73) [-.236; 2.30] <.0194>
ZD/DC ;PHI/DA -8.35 (0) (.333) [-.789; .184] [.291; 1.54] [.337; 3.19] <-2.26>

PHI/DA ;THE/DB ;PSI/DP .229 (.0268) (.159) (.333) (.333) (1.45) <.000157>
PHI/DC ;THE/DB ;PSI/DP -1.0808 (.0287) (.157) (.333) (.333) (-1.41) <.569E-4>
THE/DC ;PHI/DA ;PSI/DP .0679 (.0399) (.161) (.333) (.333) (-1.83) <-.887E-4>

PSI/DC ;PHI/DA ;THE/DB -1.0396 (.0270) (.181) (.333) (.333) (1.69) <-.365E-4>
XD/DB ;PHI/DA ;PSI/DP -1.636 (.158) (.333) (.333) (2.08) [.0534; 2.83] <-.186>
YD/DA ;THE/DB ;PSI/DP .385 (.0269) (.333) (.333) (1.45) [-.0101; 4.29] <.0308>

ZD/DC ;PHI/DA ;THE/DB 1.68 (0) (.0226) (.333) (.333) [.340; 3.20] <.0430>
ZD/DC ;PHI/DA ;PSI/DP 17.9 (.159) (.333) [.810; .184] [.281; 1.57] <.0795>
XD/DC ;PHI/DA ;THE/DB -1.0921 (0) (.333) (.333) (.398) [-.364; 3.03] <-.0374>

XD/DC ;PHI/DA ;PSI/DP -1.22 (.161) (.333) (.340) (-.647) [.288; 2.17] <.0678>
YD/DP ;PHI/DA ;THE/DB -1.184 (.0268) (.333) (.333) (1.44) (6.52) (-6.66) <.0344>
ZD/DB ;PHI/DA ;PSI/DP -8.58 (.0608) (.159) (.333) (.333) [-.161; 2.90] <-.0773>

ZD/DC ;PHI/DA ;THE/DB ;PSI/DP -3.62 (.0217) (.159) (.333) (.333) <-.00139>
XD/DC ;PHI/DA ;THE/DB ;PSI/DP .183 (.164) (.333) (.333) (-.443) <.00147>

TABLE V-5 CONTINUED
UH-IH TRANSFER FUNCTION FACTORS
CASE 132 60KT MAX CLIMB BAR OFF

DENOMINATOR: (0) (-.0708) (-.175) (.214) (.848) [.291; 1.33] [.406; 1.80] <-.0129>

CONTROL NUMERATORS:

PHI/DA .628 (0) (-.188) (.232) [.402; 1.40] [.431; 1.90] <-.194>
THE/DB -.193 (0) (-.469) (1.04) [.881; .0546] [.378; 1.80] <-.000914>
PSI/DP -1.38 (.127) (-.141) (.869) [-.217; .222] [.370; 1.39] <.00206>

PHI/DB .0619 (0) (-.150) (.191) [.433; 1.78] [.526; 2.94] <-.0486>
THE/DA .123 (0) (-.0276) (.122) (1.08) [.102; 2.04] <.00186>

PHI/DA ; THE/DB -.121 (0) (.0448) (.997) [.412; 1.95] <-.0207>
PHI/DA ; PSI/DP -.906 (.0824) (-.216) (.287) [.431; 1.30] <.00787>
THE/DB ; PSI/DP .266 (.0289) (-.242) (1.02) [.668; .578] <-.000636>

PHI/DB ; PSI/DP -.0766 (.0822) (-.172) (.222) [.613; 2.81] <.00190>
PHI/DP ; THE/DB -.0804 (0) (.0292) (.997) [.281; .921] <-.00199>
PHI/DC ; THE/DB .0227 (0) (.0379) (-3.01) [.669; 1.47] <-.00561>

THE/DA ; PSI/DP -.184 (.0316) (1.03) [-.388; .750] <-.00338>
THE/DP ; PHI/DA -.0157 (0) (.0316) (.996) (3.80) (-5.25) <.00988>
THE/DC ; PHI/DA .0269 (0) (.0325) (4.92) [.0776; 1.57] <.0106>

PSI/DA ; THE/DB -.0165 (.0448) (-.832) (.988) (2.99) (-3.81) <-.00694>
PSI/DB ; PHI/DA -.0188 (.0863) [-.0532; .404] [.244; 3.26] <-.00282>
XD/DB ; PHI/DA .711 (0) (.822) [.423; 1.97] [.0496; 2.62] <15.6>

YD/DA ; THE/DB -.190 (.0448) (.998) [.351; 1.79] [.0374; 4.88] <-.644>
ZD/DB ; PHI/DA 1.56 (0) (.0188) [.403; 1.97] [.0853; 2.69] <.824>
XD/DC ; PHI/DA .0502 (0) (-6.25) [.0739; 1.55] [.691; 3.82] <-11.0>

YD/DP ; THE/DB -.360 (.0287) (.985) [.533; 1.54] [-.451; 1.56] <-.0590>
ZD/DC ; PHI/DA -7.21 (0) (-.0543) [.268; 1.13] [.320; 1.96] <1.90>

PHI/DA ; THE/DB ; PSI/DP .175 (.0498) (.0801) (.997) <.000694>
PHI/DC ; THE/DB ; PSI/DP .0225 (.0385) (.0838) (2.87) <.000208>
THE/DC ; PHI/DA ; PSI/DP -.0279 (.0324) (.0859) (5.85) <-.000454>

PSI/DC ; PHI/DA ; THE/DB -.0833 (.0349) (.100) (.693) <-.000202>
XD/DB ; PHI/DA ; PSI/DP -1.03 (.0809) (.843) [.0551; 2.61] <-.479>
YD/DA ; THE/DB ; PSI/DP .293 (.0490) (.996) [-.0172; 4.56] <.298>

ZD/DC ; PHI/DA ; THE/DB 1.33 (0) (.0498) [.375; 1.94] <.247>
ZD/DC ; PHI/DA ; PSI/DP 10.4 (-.0528) (.0844) [.168; 1.29] <-.0771>
XD/DC ; PHI/DA ; THE/DB -.0402 (0) (3.58) [.0320; 1.48] <-.316>

XD/DC ; PHI/DA ; PSI/DP .145 (.0858) [.547; 6.14] <.470>
YD/DP ; PHI/DA ; THE/DB -.147 (.0493) (.997) (2.84) (-3.13) <.0644>
ZD/DB ; PHI/DA ; PSI/DP -2.26 (.0256) (.0802) [.0862; 2.71] <-.0340>

ZD/DC ; PHI/DA ; THE/DB ; PSI/DP -1.94 (.0568) (.0795) <-.00877>
XD/DC ; PHI/DA ; THE/DB ; PSI/DP .0322 (.0861) (4.96) <.0138>

TABLE V-5 CONTINUED
UH-IH TRANSFER FUNCTION FACTORS
CASE 132 60KT MAX CLIMB BAR ON

DENOMINATOR: (0) (.0160) (-.123) (.136) (.620) [-.282; 1.69] [.513; 1.81] [-.0979; 2.04] [-.00647>

CONTROL NUMERATORS:

PHI/DA .628 (0) (-.122) (.137) (.333) (.614) [.243; 1.65] [-.444; 1.93] [-.0217>
THE/DB -.193 (0) (.0134) (.0442) (.333) (1.00) [.494; 1.88] [-.0969; 2.03] [-.000557>
PSI/DP -1.38 (.0162) (.0623) (-.147) (.168) (.655) [.291; 1.50] [-.195; 2.12] [-.000229>

PHI/DB .0619 (0) (-.144) (.203) (.306) (.333) [.422; 1.80] [-.529; 2.95] [-.00521>
THE/DA .123 (0) (.0383) (.333) (1.07) [-.731; .278] [-.120; 2.02] [-.000531>

PHI/DA ;THE/DB -.121 (0) (.0448) (.333) (.333) (.997) [-.412; 1.95] [-.00230>
PHI/DA ;PSI/DP -.906 (.0826) (-.140) (.155) (.333) (-.641) [-.275; 1.59] [-.000874>
THE/DB ;PSI/DP .266 (.0328) (-.0453) (.129) (.333) (.000) [-.196; 2.04] [-.707E-4>

PHI/DB ;PSI/DP -.0766 (.0822) (-.171) (-.219) (.333) (.339) [-.611; 2.82] [-.000211>
PHI/DP ;THE/DB -.0804 (0) (.0308) (.249) (.333) (.997) [-.263; 1.14] [-.000266>
PHI/DC ;THE/DB .0227 (0) (-.0379) (.333) (.345) (-2.86) [-.616; 1.47] [-.000611>

THE/DA ;PSI/DP -.184 (.0316) (.333) (.333) (1.03) [-.388; .750] [-.000376>
THE/DP ;PHI/DA -.0157 (0) (.0314) (.333) (-.354) (.996) (3.61) (-5.08) [-.00107>
THE/DC ;PHI/DA .0269 (0) (-.0325) (.330) (.333) (4.85) [-.101; 1.60] [-.00119>

PSI/DA ;THE/DB -.0165 (.0448) (.333) (.333) (-.832) (.988) (2.99) (-3.81) [-.000771>
PSI/DB ;PHI/DA -.0188 (.0863) (.333) (.333) [-.0532; .404] [-.244; 3.26] [-.000313>
XD/DB ;PHI/DA .711 (0) (.333) (.333) (.822) [-.423; 1.97] [-.0496; 2.62] [-.173>

YD/DA ;THE/DB -.190 (.0448) (.333) (.333) (.998) [-.351; 1.79] [-.0374; 4.88] [-.0715>
ZD/DB ;PHI/DA 1.56 (0) (-.0188) (.333) (.333) [-.403; 1.97] [-.0853; 2.69] [-.0916>
XD/DC ;PHI/DA .0502 (0) (.333) (.386) (-5.94) [-.107; 1.58] [-.670; 3.59] [-.123>

YD/DP ;THE/DB -.360 (.0342) (-.132) (.333) (1.00) (-1.18) (1.48) [-.0705; 2.63] [-.00656>
ZD/DC ;PHI/DA -7.21 (0) (-.0462) (-.225) (.333) [-.272; 1.51] [-.293; 1.93] [-.212>

PHI/DA ;THE/DB ;PSI/DP .175 (.0498) (.0801) (.333) (.333) (.997) [-.771E-4>
PHI/DC ;THE/DB ;PSI/DP .0225 (.0385) (.0838) (.333) (.333) (2.87) [-.231E-4>
THE/DC ;PHI/DA ;PSI/DP -.0279 (.0324) (.0859) (.333) (.333) (5.85) [-.505E-4>

PSI/DC ;PHI/DA ;THE/DB -.0833 (.0349) (.100) (.333) (.333) (.693) [-.224E-4>
XD/DB ;PHI/DA ;PSI/DP -1.03 (.0809) (.333) (.333) (.843) [-.0551; 2.61] [-.0532>
YD/DA ;THE/DB ;PSI/DP .293 (.0490) (.333) (.333) (.996) [-.0172; 4.56] [-.0331>

ZD/DC ;PHI/DA ;THE/DB 1.33 (0) (.0498) (.333) (.333) [-.375; 1.94] [-.0275>
ZD/DC ;PHI/DA ;PSI/DP 10.4 (-.0461) (-.0846) (.243) (.333) [-.160; 1.61] [-.00857>
XD/DC ;PHI/DA ;THE/DB -.0402 (0) (.333) (.333) (3.58) [-.0320; 1.48] [-.0351>

XD/DC ;PHI/DA ;PSI/DP .142 (.0858) (.333) (.388) [-.486; 5.75] [-.0522>
YD/DP ;PHI/DA ;THE/DB -.147 (.0493) (.333) (.333) (.997) (2.84) (-3.13) [-.00716>
ZD/DB ;PHI/DA ;PSI/DP -2.26 (.0256) (-.0802) (.333) (.333) [-.0862; 2.71] [-.00378>

ZD/DC ;PHI/DA ;THE/DB ;PSI/DP -1.94 (.0568) (.0795) (.333) (.333) [-.000974>
XD/DC ;PHI/DA ;THE/DB ;PSI/DP .0322 (.0861) (.333) (.333) (4.96) [-.00153>

TABLE V-5 CONTINUED
 UH-IH TRANSFER FUNCTION FACTORS
 CASE 134 60 KT AUTOROTATION BAR OFF

DENOMINATOR: (0) (.0681) (1.57) [.127;.239][.423;1.46][.371;1.94]<.0490>

CONTROL NUMERATORS:

PHI/DA .531 (0) [.158;.259][.499;1.38][.365;1.90]<.245>
 THE/DB -.170 (0) (-.00405) (.0683) (1.13) (1.37) [.346;1.94]<.000272>
 PSI/DP -1.50 (1.56) [.295;.296][.0140;.303][.468;1.43]<-.0389>

PHI/DB .0315 (0) (.0635) (-.0803) [.171;1.88][.924;3.72]<-.00787>
 THE/DA .110 (0) (.0145) (-.0528) (.900) [.364;1.90]<-.000275>

PHI/DA ;THE/DB -.0901 (0) (-.00391) (1.03) [.366;1.90]<.00131>
 PHI/DA ;PSI/DP -.833 (.0600) [.157;.260][.499;1.37]<-.00636>
 THE/DB ;PSI/DP .256 (-.00403) (1.10) (1.38) [.149;.371]<-.000215>

PHI/DB ;PSI/DP -.0960 (-.121) [.981;.0781][.608;2.35]<.000392>
 PHI/DP ;THE/DB -.0757 (0) (-.00402) (1.04) (-1.27) (1.61) <-.000645>
 PHI/DC ;THE/DB -.0149 (0) (-.00536) (2.21) [-.0665;2.22]<.000872>

THE/DA ;PSI/DP -.172 (.0319) (.170) (-.210) (.900) <.000176>
 THE/DP ;PHI/DA -.00171 (0) (.0332) (3.04) [.955;1.74]<-.000524>
 THE/DC ;PHI/DA .0236 (0) (.0147) (4.58) [.367;1.91]<.00578>

PSI/DA ;THE/DB -.0133 (-.00391) (.874) (1.51) [-.192;2.48]<.000423>
 PSI/DB ;PHI/DA .0553 (.0770) [.110;.128][.0701;2.38]<.000392>
 XD/DB ;PHI/DA .524 (0) (.850) [.366;1.91][.0387;2.59]<10.9>

YD/DA ;THE/DB -.140 (-.00391) (1.03) [.351;1.93][-.0105;4.43]<.0413>
 ZD/DB ;PHI/DA 1.34 (0) (-.00628) [.378;1.91][.144;2.59]<-.206>
 XD/DC ;PHI/DA -.0328 (0) (4.07) [.365;1.92][-.193;5.06]<-12.5>

YD/DP ;THE/DB -.411 (0) (-.00403) (1.03) (1.66) [.272;2.20]<.0136>
 ZD/DC ;PHI/DA -5.91 (0) (.0740) [-.208;1.37][.374;1.89]<-2.93>

PHI/DA ;THE/DB ;PSI/DP .142 (-.00380) (.0600) (1.03) <-.334E-4>
 PHI/DC ;THE/DB ;PSI/DP .0196 (-.00744) (.0553) (2.88) <-.232E-4>
 THE/DC ;PHI/DA ;PSI/DP -.0372 (.0145) (.0599) (4.57) <-.000147>

PSI/DC ;PHI/DA ;THE/DB .00457 (0) (.0790) (-6.80) <-.00246>
 XD/DB ;PHI/DA ;PSI/DP -.822 (.0600) (.855) [.0385;2.59]<-.283>
 YD/DA ;THE/DB ;PSI/DP .238 (-.00382) (1.03) [.000124;4.23]<-.0169>

ZD/DC ;PHI/DA ;THE/DB .945 (0) (-.00322) [.369;1.89]<-.0109>
 ZD/DC ;PHI/DA ;PSI/DP 9.29 (.0610) (.0736) [.213;1.36]<.0767>
 XD/DC ;PHI/DA ;THE/DB -.0177 (0) (5.00) [.362;1.91]<-.324>

XD/DC ;PHI/DA ;PSI/DP .0514 (.0599) (4.11) [-.192;5.06]<.323>
 YD/DP ;PHI/DA ;THE/DB -.122 (-.00380) (1.03) (2.59) (-2.63) <-.00326>
 ZD/DB ;PHI/DA ;PSI/DP -2.11 (-.00642) (.0601) [.143;2.60]<.00549>

ZD/DC ;PHI/DA ;THE/DB ;PSI/DP -1.48 (-.00307) (.0602) <.000275>
 XD/DC ;PHI/DA ;THE/DB ;PSI/DP .0279 (.0597) (4.95) <.00825>

TABLE V-5 CONCLUDED
UH-IH TRANSFER FUNCTION FACTORS

CASE 134 60 KT AUTOROTATION BAR ON

DENOMINATOR: (0) (.0181) (.586) [-.222; .167] [.523; 1.55] [.303; 1.76] [.383; 2.18] <-.0105>

CONTROL NUMERATORS:

PHI/DA .531 (0) (.333) (.583) [-.227; .168] [.351; 1.62] [.366; 1.90] <.0272>
THE/DB -.170 (0) (-.00397) (.0181) (.333) (1.02) [.496; 1.80] [.343; 2.06] <-.575E-4>
PSI/DP -1.50 (.587) [-.470; .132] [.206; .168] [.401; 1.57] [.426; 2.01] <-.00432>

PHI/DB .0315 (0) (.0638) (-.0828) (.333) (.347) [-.179; 1.88] [.938; 3.64] <-.000899>
THE/DA .104 (0) (.0148) (-.0522) (.333) (.333) (.899) [.364; 1.90] <-.289E-4>

PHI/DA ;THE/DB -.0901 (0) (-.00391) (.333) (.333) (1.03) [.366; 1.90] <.000146>
PHI/DA ;PSI/DP -.833 (.0600) (.333) (.585) [-.228; .168] [.350; 1.61] <-.000707>
THE/DB ;PSI/DP .256 (-.00402) (.333) (1.03) [-.457; .132] [.449; 1.98] <-.238E-4>

PHI/DB ;PSI/DP -.0959 (-.121) (.333) (.333) [.981; .0781] [.608; 2.35] <.435E-4>
PHI/DP ;THE/DB -.0757 (0) (-.00403) (.333) (.392) (1.04) (-1.16) (1.44) <-.696E-4>
PHI/DC ;THE/DB -.0149 (0) (-.00541) (.333) (.345) (2.14) [-.0796; 2.21] <.970E-4>

THE/DA ;PSI/DP -.172 (.0319) (.170) (-.210) (.333) (.333) (.900) <.195E-4>
THE/DP ;PHI/DA -.00171 (0) (.0331) (.330) (.333) (2.95) [.962; 1.78] <-.582E-4>
THE/DC ;PHI/DA .0236 (0) (.0147) (.333) (.333) (4.58) [.367; 1.91] <.000642>

PSI/DA ;THE/DB -.0133 (-.00391) (.333) (.333) (.874) (1.51) [.192; 2.48] <.470E-4>
PSI/DB ;PHI/DA .0553 (.0770) (.333) (.333) [.110; .128] [.0701; 2.38] <.435E-4>
XD/DB ;PHI/DA .524 (0) (.333) (.333) (.850) [.366; 1.91] [.0387; 2.59] <1.21>

YD/DA ;THE/DB -.140 (-.00391) (.333) (.333) (1.03) [.351; 1.93] [-.0105; 4.43] <.00459>
ZD/DB ;PHI/DA 1.34 (0) (-.00628) (.333) (.333) [.378; 1.91] [.144; 2.59] <-.0229>
XD/DC ;PHI/DA -.0328 (0) (.333) (.382) (4.01) [.366; 1.91] [-.204; 4.76] <-1.39>

YD/DP ;THE/DB -.348 (-.00402) (.179) (.333) (1.03) (1.87) (-1.91) [-.222; 2.75] <-.00233>
ZD/DC ;PHI/DA -5.91 (0) (.0882) (.193) (.333) [.207; 1.65] [.377; 1.89] <-.326>

PHI/DA ;THE/DB ;PSI/DP .142 (-.00380) (.0600) (.333) (.333) (1.03) <-.371E-5>
PHI/DC ;THE/DB ;PSI/DP .0196 (-.00744) (.0553) (.333) (.333) (2.88) <-.257E-5>
THE/DC ;PHI/DA ;PSI/DP -.0372 (.0145) (.0599) (.333) (.333) (4.57) <-.164E-4>

PSI/DC ;PHI/DA ;THE/DB .00457 (0) (.0790) (.333) (.333) (-6.80) <-.000273>
XD/DB ;PHI/DA ;PSI/DP -.822 (.0600) (.333) (.333) (.855) [.0385; 2.59] <-.0315>
YD/DA ;THE/DB ;PSI/DP .238 (-.00382) (.333) (.333) (1.03) [.000123; 4.23] <-.00188>

ZD/DC ;PHI/DA ;THE/DB .945 (0) (-.00322) (.333) (.333) [-.369; 1.89] <-.00121>
ZD/DC ;PHI/DA ;PSI/DP -.929 (0) (.0607) (.0888) (.191) (.333) [.215; 1.64] <-.000852>
XD/DC ;PHI/DA ;THE/DB -.0177 (0) (.333) (.333) (5.00) [-.362; 1.91] <-.0360>

XD/DC ;PHI/DA ;PSI/DP .0514 (.0599) (.333) (.381) (4.05) [-.203; 4.76] <.0359>
YD/DP ;PHI/DA ;THE/DB -.122 (-.00380) (.333) (.333) (1.03) (2.59) (-2.63) <-.000362>
ZD/DB ;PHI/DA ;PSI/DP -2.11 (-.00642) (.0601) (.333) (.333) [-.143; 2.60] <.000610>

ZD/DC ;PHI/DA ;THE/DB ;PSI/DP -1.48 (-.00307) (.0602) (.333) (.333) <.305E-4>
XD/DC ;PHI/DA ;THE/DB ;PSI/DP .0279 (.0597) (.333) (.333) (4.95) <.000917>

SECTION VI
SIKORSKY CH-53D

The CH-53D is a twin-turbine heavy assault transport helicopter. With a maximum gross weight of 19050 kg (42,000 lb), it carries a crew of three and up to 64 troops. The rotor system consists of a six-bladed, fully-articulated main rotor and is powered by two T64-GE-412 (or -413) engines rated at 3695 (or 3925) shaft horsepower.

The vehicle features a highly augmented flight control system as shown in Fig. VI-2. The mechanical control system is powered by hydraulic actuators. Collective control is cross fed to both the lateral cyclic and tail rotor controls to offset roll and yaw moments produced by collective pitch changes. An electronic automatic flight control system (AFCS) is normally utilized which includes command augmentation of the longitudinal cyclic control, rate damping about all axes, attitude and heading stabilization, and turn coordination at airspeeds above 60 kt.

The data presented here were produced by the manufacturer's GENHEL computer program. Transfer function data are limited to a controls-fixed condition; control forces are not modeled. The CH-53D, however, employs automatic control force trim functions for the lateral cyclic stick and for the rudder pedals. These automatic trim devices effectively provide additional feedback loops if control inputs are regarded on a force basis.

All the basic data in Ref. 6 were transcribed except for the elements of a linearized propulsion system model and its respective stability derivatives. Miscellaneous descriptive data shown in Table VI-1 were obtained from the NATOPS Flight Manual (Ref. 13).

TABLE VI-1
CH-53D DESCRIPTIVE DATA

MAIN ROTOR

Blades 6
 Radius 11.009 m (36.118 ft)
 Chord 0.660 m (2.167 ft)
 Section NACA 0011 Mod
 Hub type Articulated
 Twist -4.1 deg*
 Pitch flap coupling (δ_3) Zero
 Shaft tilt 5 deg forward
 Design rpm 185 rpm = 100% N_r , max rpm = 125% N_r †
 Hub location FS 336.413, WL 257‡
 Blade flapping inertia 5486 kg-m² (4046 slug-ft²)

TAIL ROTOR

Blades 4
 Radius 2.44 m (8 ft)
 Chord 0.391 m (1.284 ft)
 Twist -8 deg*
 RPM ratio 4.30
 Hub location FS 870.25, WL 269., BL -33.‡

HORIZONTAL STABILIZER

Area 3.71 m² (40.0 ft²)
 Aspect ratio 2.59
 Center of pressure location FS 846, BL 60.9, WL 290.0
 Dihedral 5 deg
 Incidence 3 deg

VERTICAL STABILIZER LOCATION

Area 3.252 m² (35.0 ft²)
 Aspect ratio 1.70
 Center of pressure location FS 812.5, WL 228.9

* From Ref. 12.

† From Ref. 13.

‡ Manufacturer's fuselage reference system.

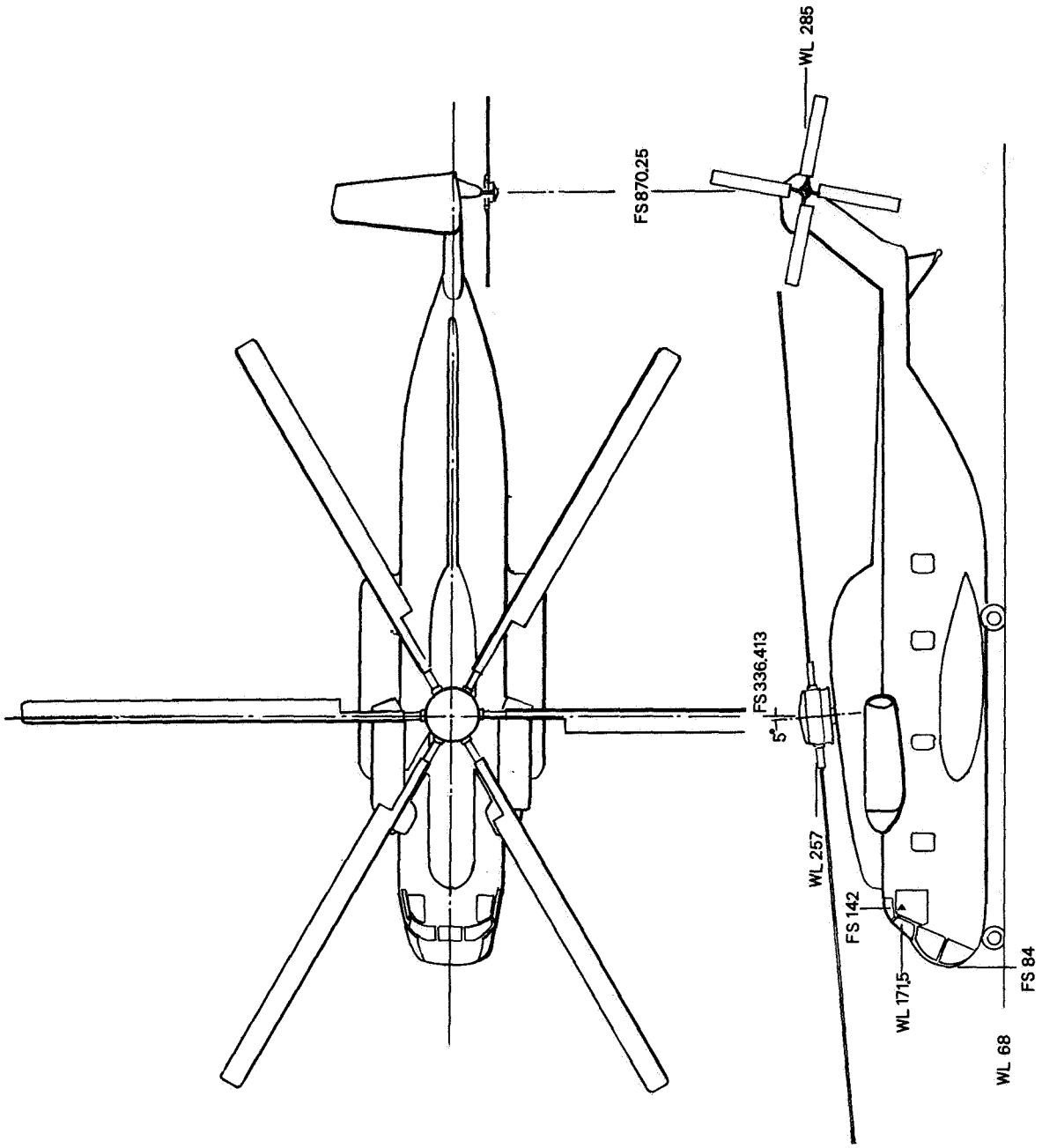

Figure VI-1. CH-53D General Arrangement

a. Block Diagram

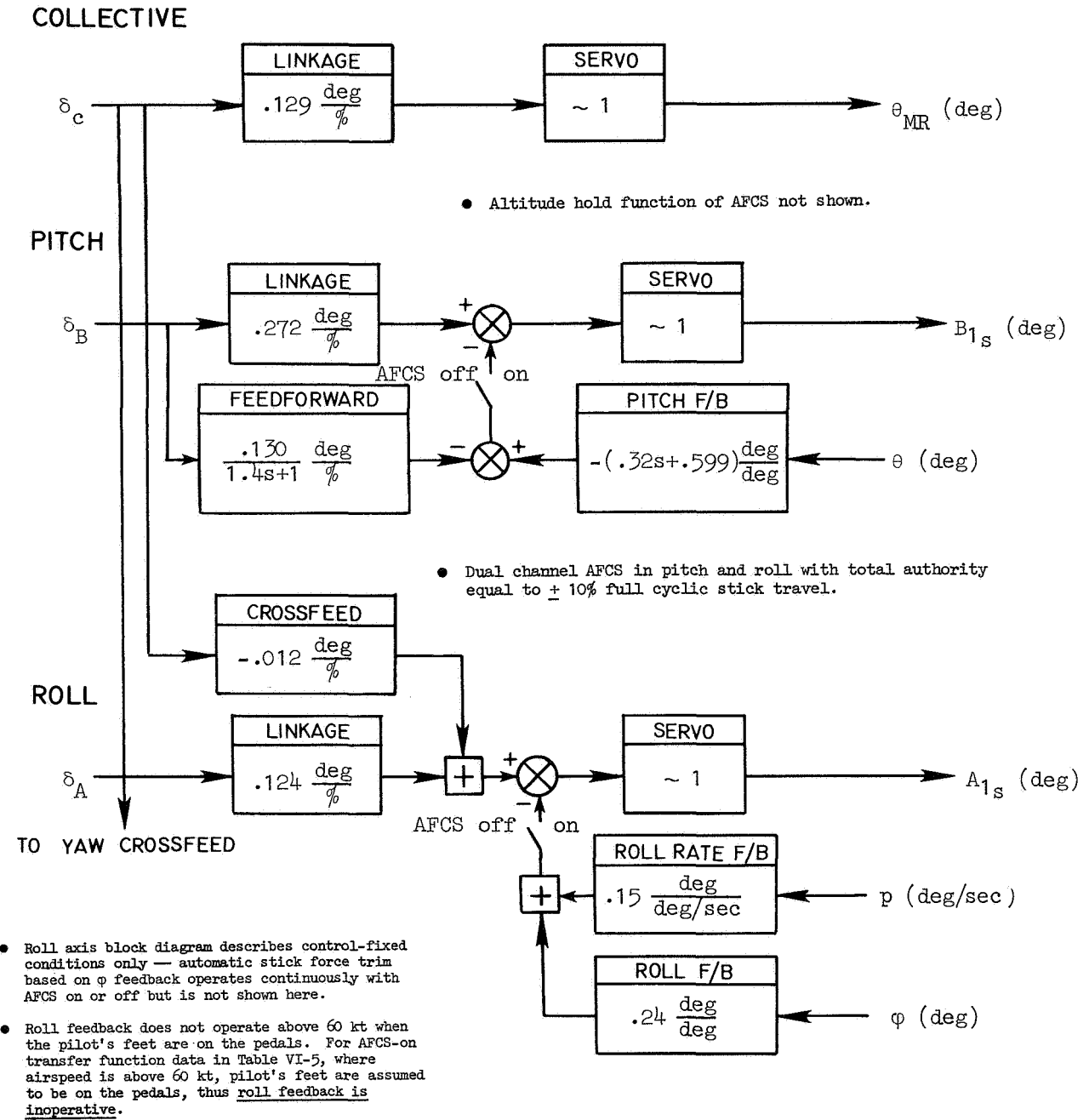
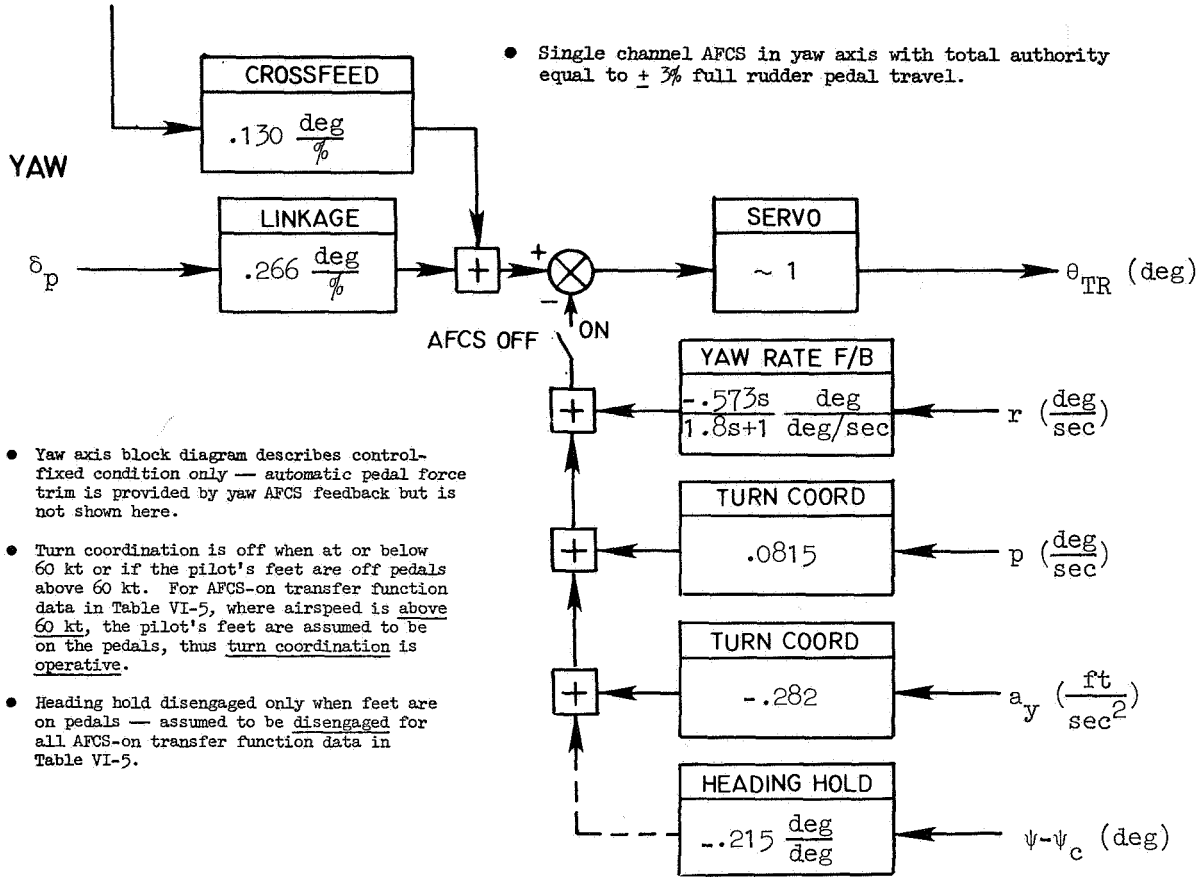

Figure VI-2. CH-53D Control System Description

FROM COLLECTIVE CONTROL



b. Cockpit Controller Characteristics

CONTROLLER	100% FULL TRAVEL cm (in)
Collective, δ_c	25.4 (10)
Longitudinal Cyclic, δ_B	31.04 (12.22)
Lateral Cyclic, δ_A	22.61 (8.9)
Pedal, δ_p	12.95 (5.10)

Figure VI-2 (Concluded)

a. Loading Envelope

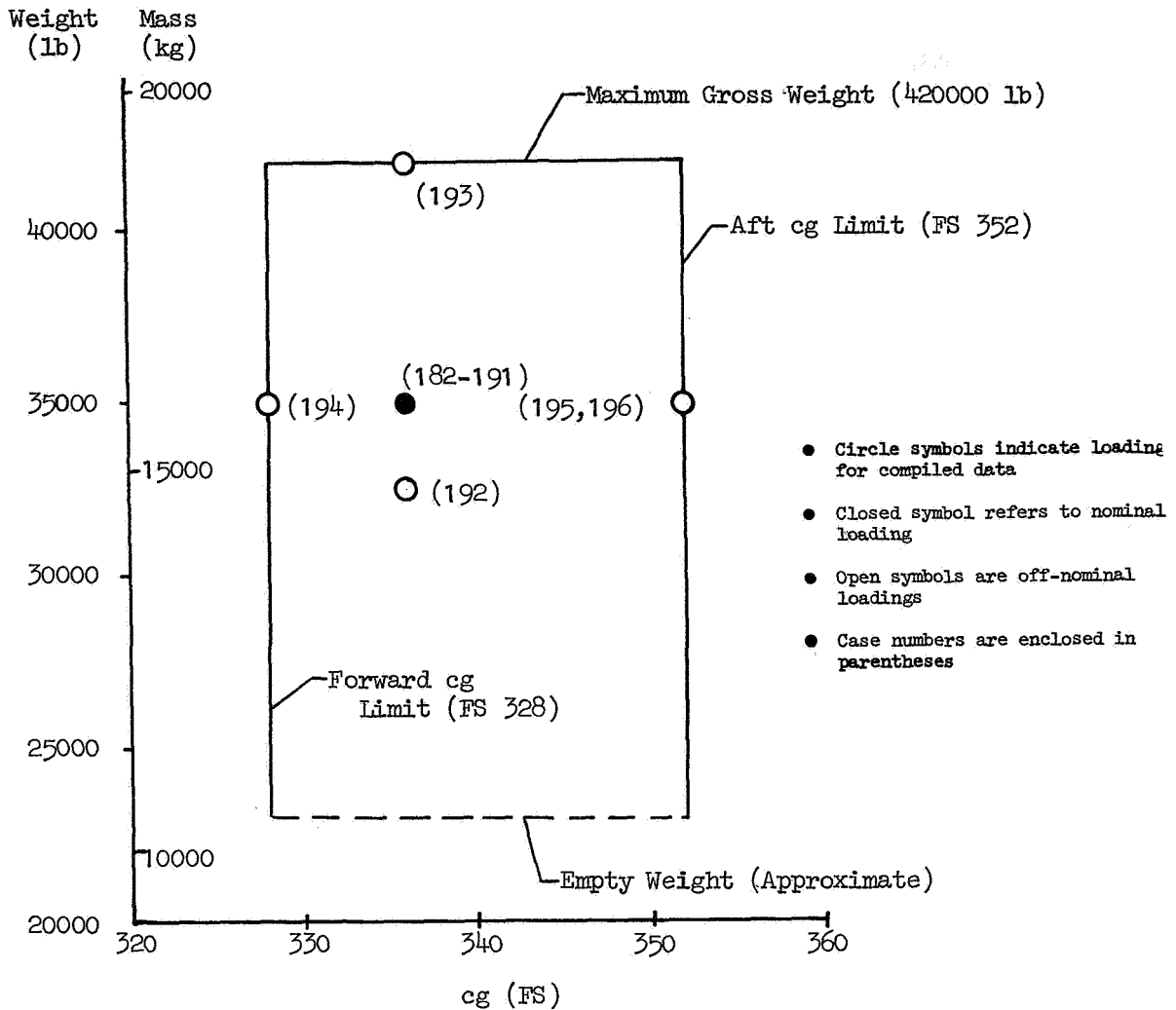

b. Moments of Inertia for Compiled Data

CONDITION	MASS (WEIGHT) kg (lb)	cg		I_x	I_y kg-m ² (slug-ft ²)	I_z	I_{xz}
		FS	WL				
Nominal Weight, mid cg	15876 (35000)	336	163.8	48967(36116)	259611(191479)	242965(179202)	20050(14788)
..., Forward cg	↓	328	↓	↓	258175(190420)	241025(177771)	23850(17591)
..., Aft cg	↓	352	↓	↓	262481(193596)	246848(182066)	12450(9183)
Light Weight	15195 (33500)	336	165.5	47658(35151)	254182(187475)	237698(175317)	20051(14789)
Heavy Weight	19051 (42000)	336	155.7	55076(40622)	284943(210163)	267549(197334)	20047(14786)

• Inertias were calculated by interpolating data given in Ref. 6 over weight and cg ranges.

Figure VI-3. CH-53D Loading Summary

TABLE VI-2

CH-53D INDEX OF FLIGHT CONDITIONS
FOR DERIVATIVES AND TRANSFER FUNCTION FACTORS

CASE	CONDITION	AIRSPEED kt	VERTICAL VELOCITY m/sec(ft/sec)	ALTITUDE m(ft)	MASS (WEIGHT) kg(lb)	cg FS	REPORT PAGE NUMBER		
							DERIVA- TIVES SI(US)	TRANSFER FUNCTIONS	
								AFCS OFF	AFCS ON
182	Airspeed Variation	Hover	Zero	610(2000)	15876(35000)	336	310(316)	322*	326*
183		20						330*	334*
184		30							
185		40					311(317)	338	339
186		60						340*	344*
187		80						348	349
188		100					312(318)	350	351
189		120						352	353
190		140						354	355
191		150					313(319)	356	357
192	Reduced Weight				15195(33500)				
193	Max Gross Weight				19051(42000)				
194	Fwd cg				15876(35000)	328	314(320)		
195	Aft cg	100				352			
196		150				352			
197	Operation at Altitude	100		1524(5000)		336	315(321)		
198	Reduced Rotor rpm								
	$N_r = 96\%$	120							
199	Increased Rotor rpm								
	$N_r = 104\%$	120							

TABLE VI-3
CH-53D STABILITY AND CONTROL DERIVATIVES -- SI UNITS
(BODY-FIXED FRL AXIS SYSTEM)

CASE 182	0 KT			LEVEL FLIGHT	610 M	15876 KG	MID CG			
	PHI	THETA	PSI	ALPHA	BETA	GAMMA	ΘMR	B1S	A1S	ΘTR
	-3.14	5.64	-0.31	5.65	0.00	0.00	14.02	0.22	-0.89	19.56
	XDOT	ZDOT	UO	VO	WO	VT0				
	0.00	0.00	0.00	0.00	0.00	0.00				
	U	W	Q	V	P	R	DC	DB	DA	DP
X	-0.0917	0.0240	0.2652	0.0029	-0.8595	-0.1152	0.0755	0.1823	0.0117	-0.0001
Z	0.0168	-0.2980	0.0881	-0.1660	-0.0924	1.0942	-0.7661	0.0163	0.0004	-0.0001
H	0.0196	-0.0058	-0.4990	0.0066	0.1970	0.0063	0.0007	-0.0705	-0.0030	0.0007
Y	0.0030	-0.0025	-0.8382	-0.1450	-0.5852	0.3505	0.0117	-0.0217	0.1159	0.1465
L'	0.0087	-0.0010	-0.9370	-0.1017	-1.9000	0.2100	-0.0149	-0.0309	0.2029	0.0904
N'	-0.0028	0.0011	0.0870	0.0089	-0.1000	-0.3400	0.0327	-0.0019	0.0128	-0.1385

CASE 183	20 KT			LEVEL FLIGHT	610 M	15876 KG	MID CG			
	PHI	THETA	PSI	ALPHA	BETA	GAMMA	ΘMR	B1S	A1S	ΘTR
	-2.65	4.55	-0.21	4.55	0.00	0.00	13.39	1.87	-0.93	16.73
	XDOT	ZDOT	UO	VO	WO	VT0				
	10.29	0.00	10.26	-0.00	0.82	10.29				
	U	W	Q	V	P	R	DC	DB	DA	DP
X	-0.0216	0.0336	0.5671	0.0012	-0.8016	-0.0972	0.0490	0.1747	0.0104	-0.0010
Z	-0.1430	-0.3750	-0.0913	-0.0167	-0.2637	1.0028	-0.7519	0.0915	0.0117	0.0002
H	0.0052	-0.0052	-0.3600	-0.0037	0.2030	0.0030	0.0114	-0.0736	-0.0033	0.0006
Y	0.0377	0.0033*	-1.0424	-0.1780	-0.6031	0.4296	0.0046	-0.0279	0.1138	0.1379
L'	0.0301	0.0045	-1.0700	-0.1161	-1.5200	0.2420	-0.0106	-0.0359	0.2011	0.0850
N'	-0.0351	-0.0070	0.0923	0.0338	-0.1340	-0.4770	0.0362	0.0063	0.0126	-0.1302

CASE 184	30 KT			LEVEL FLIGHT	610 M	15876 KG	MID CG			
	PHI	THETA	PSI	ALPHA	BETA	GAMMA	ΘMR	B1S	A1S	ΘTR
	-2.27	3.61	-0.14	3.61	0.00	0.00	12.64	1.27	-0.96	14.13
	XDOT	ZDOT	UO	VO	WO	VT0				
	15.43	0.00	15.40	-0.00	0.97	15.43				
	U	W	Q	V	P	R	DC	DB	DA	DP
X	-0.0160	0.0434	0.5671	-0.0001	-0.7620	-0.0543	0.0061	0.1643	0.0082	-0.0066
Z	-0.1740	-0.4740	0.0019	-0.0140	-0.3444	0.9418	-0.7529	0.1477	0.0176	0.0010
H	0.0213	-0.0140	-0.3250	-0.0024	0.1850	-0.0109	0.0241	-0.0693	-0.0031	0.0010
Y	0.0035	-0.0073	-0.9510	-0.1250	-0.6988	0.4309	0.0144	-0.0266	0.1069	0.1254
L'	0.0081	-0.0001	-1.0000	-0.0973	-1.5400	0.2610	0.0039	-0.0315	0.1990	0.0872
N'	-0.0042	-0.0016	0.1010	0.0277	-0.0990	-0.4970	0.0155	0.0011	0.0122	-0.1327

*This derivative was transcribed accurately from the original source but exceeds the usual range of values and should be used with due caution.

TABLE VI-3 CONTINUED
 CH-53D STABILITY AND CONTROL DERIVATIVES -- SI UNITS
 (BODY-FIXED FRL AXIS SYSTEM)

CASE 185		40 KT		LEVEL FLIGHT		610 M		15876 KG		MID CG	
PHI	THETA	PSI	ALPHA	BETA	GAMMA	ΘHR	BIS	AIS	ΘTR		
-1.88	2.69	-0.09	2.69	0.00	0.00	11.86	0.36	-1.01	12.71		
XDOT		ZDOT	U0	V0	W0	VTO					
20.58		0.00	20.56	-0.00	0.97	20.58					
U	W	Q	V	P	R	DC	DB	DA	DP		
X	-0.0152	0.0264	0.6279	0.0000	-0.7254	-0.0555	0.0128	0.1612	0.0087	-0.0012	
Z	-0.1660	-0.5720	0.0403	-0.0121	-0.3962	0.9053	-0.7822	0.1976	0.0221	0.0001	
H	0.0320	-0.0052	-0.3500	-0.0021	0.1800	0.0079	0.0091	-0.0678	-0.0029	0.0006	
Y	0.0044	-0.0076	-0.8656	-0.0953	-0.7404	0.4474	0.0220	-0.0173	0.1079	0.1416	
L'	0.0088	0.0002	-0.9660	-0.0577	-1.5600	0.2650	0.0069	-0.0312	0.1964	0.0872	
N'	-0.0066	-0.0039	0.1680	0.0254	-0.0939	-0.5020	0.0105	0.0017	0.0113	-0.1342	

CASE 186		60 KT		LEVEL FLIGHT		610 M		15876 KG		MID CG	
PHI	THETA	PSI	ALPHA	BETA	GAMMA	ΘHR	BIS	AIS	ΘTR		
-1.41	2.44	-0.06	2.44	0.00	0.00	11.21	1.59	-0.97	10.97		
XDOT		ZDOT	U0	V0	W0	VTO					
30.87		0.00	30.84	-0.00	1.31	30.87					
U	W	Q	V	P	R	DC	DB	DA	DP		
X	-0.0272	0.0295	-0.6013	-0.0006	-0.6828	-0.0954	0.0129	0.1423	0.0030	-0.0155	
Z	-0.0623	-0.6570	-0.2002	-0.0148	-0.6309	0.9876	-0.9235	0.3190	0.0385	0.0042	
H	0.0074	0.0022	-0.4510	-0.0030	0.1800	0.0155	0.0122	-0.0685	-0.0027	0.0012	
Y	0.0058	-0.0090	-0.7925	-0.1020	-0.7780	0.4958	0.0193	-0.0164	0.1035	0.1475	
L'	0.0085	0.0036	-0.9460	-0.0564	-1.5800	0.2930	0.0174	-0.0330	0.1940	0.0943	
N'	-0.0071	-0.0079	0.1150	0.0268	-0.0826	-0.5610	0.0033	0.0050	0.0118	-0.1421	

CASE 187		80 KT		LEVEL FLIGHT		610 M		15876 KG		MID CG	
PHI	THETA	PSI	ALPHA	BETA	GAMMA	ΘHR	BIS	AIS	ΘTR		
-1.31	1.47	-0.03	1.47	0.00	0.00	11.32	2.54	-0.99	10.25		
XDOT		ZDOT	U0	V0	W0	VTO					
41.16		0.00	41.14	-0.00	1.06	41.16					
U	W	Q	V	P	R	DC	DB	DA	DP		
X	-0.0344	0.0301	0.6293	0.0004	-0.6462	-0.0881	0.0084	0.1391	0.0042	-0.0069	
Z	-0.0162	-0.7370	-0.4512	-0.0188	-0.9083	1.0698	-1.0203	0.4508	0.0550	0.0030	
H	0.0073	0.0069	-0.5140	-0.0041	0.1830	0.0160	0.0194	-0.0705	-0.0029	0.0011	
Y	0.0060	-0.0076	-0.7711	-0.1200	-0.7821	0.5731	0.0268	-0.0119	0.1040	0.1699	
L'	0.0075	0.0073	-0.9490	-0.0621	-1.5700	0.3180	0.0304	-0.0376	0.1928	0.1040	
N'	-0.0056	-0.0105	0.1190	0.0262	-0.0785	-0.6450	-0.0056	0.0071	0.0113	-0.1589	

TABLE VI-3 CONTINUED
 CH-53D STABILITY AND CONTROL DERIVATIVES -- SI UNITS
 (BODY-FIXED FRL AXIS SYSTEM)

CASE 188	100 KT			LEVEL FLIGHT		610 M	15876 KG	MID CG		
	PHI	THETA	PSI	ALPHA	BETA	GAMMA	ΘMR	B1S	A1S	ΘTR
	-2.29	0.38	1.99	0.30	-2.00	0.00	12.03	3.87	-1.35	9.65
	IDOT	ZDOT	U0	V0	W0	VTO				
	51.44	0.00	51.41	-1.80	0.27	51.44				
	U	W	Q	V	P	R	DC	DB	DA	DP
X	-0.0400	0.0309	0.5126	-0.0042	-0.6370	-0.1096	-0.0031	0.1302	0.0032	-0.0122
Z	0.0143	-0.7920	-0.5717	-0.0243	-1.2285	1.1796	-1.1015	0.5967	0.0621	0.0072
H	0.0072	0.0091	-0.5580	-0.0056	0.1910	0.0183	0.0273	-0.0723	-0.0029	0.0022
Y	0.0094	-0.0076	-0.7864	-0.1410	-0.6928	0.5717	0.0323	-0.0113	0.1033	0.1842
L*	0.0076	0.0136	-0.9630	-0.0656	-1.5300	0.3400	0.0476	-0.0448	0.1922	0.1137
N*	-0.0051	-0.0077	0.1390	0.0279	-0.0701	-0.7220	-0.0091	0.0094	0.0114	-0.1711

CASE 189	120 KT			LEVEL FLIGHT		610 M	15876 KG	MID CG		
	PHI	THETA	PSI	ALPHA	BETA	GAMMA	ΘMR	B1S	A1S	ΘTR
	-3.01	-1.10	2.06	-1.21	-2.00	0.00	13.34	5.42	-1.66	9.99
	IDOT	ZDOT	U0	V0	W0	VTO				
	61.73	0.00	61.68	-2.15	-1.30	61.73				
	U	W	Q	V	P	R	DC	DB	DA	DP
X	-0.0469	0.0258	0.4686	-0.0053	-0.6401	-0.1133	-0.0158	0.1326	0.0049	-0.0087
Z	0.0353	-0.8300	-0.9049	-0.0337	-1.5571	1.3228	-1.1635	0.7272	0.0797	0.0102
H	0.0074	0.0122	-0.6060	-0.0064	0.2060	0.0193	0.0364	-0.0760	-0.0030	0.0038
Y	0.0113	-0.0067	-0.8443	-0.1630	-0.6362	0.6001	0.0367	-0.0128	0.1039	0.1969
L*	0.0083	0.0198	-1.0200	-0.0719	-1.4800	0.3490	0.0636	-0.0549	0.1926	0.1230
N*	-0.0059	-0.0045	0.1840	0.0295	-0.0676	-0.8060	-0.0091	0.0098	0.0113	-0.1837

CASE 190	140 KT			LEVEL FLIGHT		610 M	15876 KG	MID CG		
	PHI	THETA	PSI	ALPHA	BETA	GAMMA	ΘMR	B1S	A1S	ΘTR
	-3.88	-2.89	2.20	-3.03	-2.00	0.00	15.45	7.58	-2.16	10.86
	IDOT	ZDOT	U0	V0	W0	VTO				
	72.02	0.00	71.88	-2.51	-3.81	72.02				
	U	W	Q	V	P	R	DC	DB	DA	DP
X	-0.0540	0.0162	0.4019	-0.0055	-0.6614	-0.0773	-0.0289	0.1596	0.0143	0.0188
Z	0.0494	-0.8610	-1.3773	-0.0457	-1.9070	1.4630	-1.1746	0.8251	0.0955	0.0048
H	0.0075	0.0146	-0.6560	-0.0068	0.2340	0.0178	0.0480	-0.0834	-0.0036	0.0048
Y	0.0137	-0.0037	-0.9418	-0.1860	-0.4933	0.6458	0.0451	-0.0146	0.1078	0.2132
L*	0.0098	0.0287	-1.1000	-0.0784	-1.4300	0.3490	0.0840	-0.0693	0.1944	0.1320
N*	-0.0070	0.0014	0.2570	0.0319	-0.0773	-0.9060	-0.0081	0.0087	0.0109	-0.1977

TABLE VI-3 CONTINUED
 CH-53D STABILITY AND CONTROL DERIVATIVES -- SI UNITS
 (BODY-FIXED FRL AXIS SYSTEM)

CASE 191		150 KT	LEVEL FLIGHT	610 M	15876 KG	MID CG				
PHI	THETA	PSI	ALPHA	BETA	GAMMA	ΘHR	B1S	A1S	ΘTR	
-4.44	-3.85	2.30	-4.02	-2.00	0.00	16.83	8.97	-2.50	11.52	
XDOT		ZDOT	U0	V0	W0	VT0				
77.17		0.00	76.93	-2.69	-5.40	77.17				
U	W	Q	V	P	R	DC	DB	DA	DP	
X	-0.0601	0.0069	0.4381	-0.0050	-0.6828	-0.0684	-0.0421	0.1766	0.0179	0.0265
Z	0.0578	-0.8530	-1.7056	-0.0562	-2.0896	1.5301	-1.1607	0.8447	0.1003	-0.0102
H	0.0081	0.0162	-0.7020	-0.0084	0.2440	0.0123	0.0512	-0.0905	-0.0055	-0.0003
Y	0.0154	-0.0014	-0.9997	-0.1980	-0.4229	0.6693	0.0500	-0.0149	0.1119	0.2253
L'	0.0109	0.0341	-1.1700	-0.0823	-1.4200	0.3500	0.0943	-0.0783	0.1965	0.1370
M'	-0.0081	0.0002	0.2600	0.0328	-0.0997	-0.9750	-0.0081	0.0041	0.0088	-0.2120

CASE 192		100 KT	LEVEL FLIGHT	610 M	15195 KG	MID CG				
PHI	THETA	PSI	ALPHA	BETA	GAMMA	ΘHR	B1S	A1S	ΘTR	
-2.42	0.31	1.99	0.23	-2.00	0.00	11.80	3.73	-1.29	9.48	
XDOT		ZDOT	U0	V0	W0	VT0				
51.44		0.00	51.41	-1.80	0.20	51.44				
U	W	Q	V	P	R	DC	DB	DA	DP	
X	-0.0407	0.0366	0.5622	-0.0032	-0.6218	-0.1005	0.0091	0.1320	0.0061	-0.0016
Z	0.0170	-0.8360	-0.6025	-0.0251	-1.2742	1.1887	-1.1559	0.6219	0.0625	0.0014
H	0.0068	0.0082	-0.5510	-0.0057	0.1850	0.0167	0.0252	-0.0714	-0.0032	0.0009
Y	0.0095	-0.0082	-0.7833	-0.1460	-0.7359	0.6025	0.0331	-0.0111	0.1034	0.1925
L'	0.0070	0.0127	-0.9350	-0.0640	-1.4900	0.3410	0.0461	-0.0444	0.1890	0.1137
M'	-0.0048	-0.0066	0.1260	0.0278	-0.0672	-0.7220	-0.0105	0.0068	0.0104	-0.1747

CASE 193		100 KT	LEVEL FLIGHT	610 M	19051 KG	MID CG				
PHI	THETA	PSI	ALPHA	BETA	GAMMA	ΘHR	B1S	A1S	ΘTR	
-1.94	0.93	1.97	0.86	-2.00	0.00	13.08	4.55	-1.57	10.34	
XDOT		ZDOT	U0	V0	W0	VT0				
51.44		0.00	51.41	-1.80	0.77	51.44				
U	W	Q	V	P	R	DC	DB	DA	DP	
X	-0.0383	0.0165	0.6767	-0.0032	-0.6492	-0.0944	-0.0223	0.1471	0.0056	-0.0019
Z	0.0057	-0.6320	-0.6836	-0.0239	-1.0700	1.1003	-0.8663	0.4718	0.0520	0.0023
H	0.0091	0.0117	-0.6110	-0.0053	0.2150	0.0186	0.0320	-0.0798	-0.0031	0.0010
Y	0.0092	-0.0049	-0.8077	-0.1240	-0.8007	0.4752	0.0289	-0.0116	0.1032	0.1545
L'	0.0103	0.0168	-1.1200	-0.0074	-1.7400	0.3360	0.0512	-0.0474	0.2062	0.1144
M'	-0.0070	-0.0151	0.1960	0.0272	-0.1070	-0.7390	-0.0119	0.0140	0.0111	-0.1751

TABLE VI-3 CONTINUED
 CH-53D STABILITY AND CONTROL DERIVATIVES -- SI UNITS
 (BODY-FIXED FRL AXIS SYSTEM)

CASE 194	100 KT		LEVEL FLIGHT		610 M	15876 KG	FWD CG			
	PHI	THETA	PSI	ALPHA	BETA	GAMMA	ΘHR	B1S	A1S	ΘTR
	-2.23	-1.47	2.06	-1.55	-2.00	0.00	12.13	2.20	-1.54	9.57
	XDOT	ZDOT	UO	VO	WO	VT0				
	51.44	0.00	51.39	-1.80	-1.39	51.44				
	U	W	Q	V	P	R	DC	DB	DA	DP
X	-0.0396	0.0088	0.5030	-0.0041	-0.6767	-0.0548	-0.0351	0.1561	0.0079	-0.0022
Z	-0.0066	-0.8100	-0.7061	-0.0229	-1.1340	1.2192	-1.0928	0.5818	0.0605	0.0019
M	0.0072	-0.0001	-0.5650	-0.0059	0.1810	0.0211	0.0181	-0.0684	-0.0027	0.0010
Y	0.0090	-0.0093	-0.7955	-0.1430	-0.7225	0.5842	0.0295	-0.0121	0.1037	0.1807
L'	0.0086	0.0138	-0.9770	-0.0646	-1.5400	0.3430	0.0464	-0.0447	0.1925	0.1134
M'	-0.0057	-0.0083	0.2580	0.0320	-0.0626	-0.7470	-0.0114	0.0089	0.0086	-0.1776

CASE 195	100 KT		LEVEL FLIGHT		610 M	15876 KG	APT CG			
	PHI	THETA	PSI	ALPHA	BETA	GAMMA	ΘHR	B1S	A1S	ΘTR
	-2.49	4.03	1.83	3.95	-2.00	0.00	11.90	7.27	-0.95	9.90
	XDOT	ZDOT	UO	VO	WO	VT0				
	51.44	0.00	51.29	-1.80	3.54	51.44				
	U	W	Q	V	P	R	DC	DB	DA	DP
X	-0.0456	0.0749	0.5489	-0.0037	-0.5456	-0.2041	0.0672	0.0823	-0.0038	-0.0242
Z	0.0530	-0.7920	-0.3286	-0.0268	-1.4022	1.0759	-1.0975	0.6032	0.0650	0.0159
M	0.0058	0.0237	-0.5390	-0.0047	0.2180	0.0162	0.0465	-0.0798	-0.0030	0.0058
Y	0.0099	-0.0037	-0.7559	-0.1380	-0.6281	0.5724	0.0490	-0.0018	0.1079	0.2115
L'	0.0054	0.0106	-0.9440	-0.0663	-1.4800	0.3310	0.0505	-0.0466	0.1904	0.1144
M'	-0.0042	-0.0066	-0.0948*	0.0210	-0.0826	-0.6650	-0.0027	0.0116	0.0175	-0.1546

CASE 196	150 KT		LEVEL FLIGHT		610 M	15876 KG	APT CG			
	PHI	THETA	PSI	ALPHA	BETA	GAMMA	ΘHR	B1S	A1S	ΘTR
	-4.68	-0.32	2.03	-0.49	-2.00	0.00	16.42	12.03	-2.04	11.71
	XDOT	ZDOT	UO	VO	WO	VT0				
	77.17	0.00	77.12	-2.69	-0.66	77.17				
	U	W	Q	V	P	R	DC	DB	DA	DP
X	-0.0652	0.0584	0.5050	0.0005	-0.4785	-0.1507	0.0600	0.1150	0.0183	0.0532
Z	0.0967	-0.8260	-1.3436	-0.0587	-2.3182	1.3594	-1.2149	0.8829	0.0967	-0.0230
M	0.0052	0.0328	-0.6570	-0.0063	0.2820	0.0038	0.0694	-0.1020	-0.0075	0.0006
Y	0.0152	0.0031*	-0.9327	-0.1910	-0.2947	0.6425	0.0657	-0.0090	0.1102	0.2454
L'	0.0653	0.0121	-1.1100	-0.0840	-1.3000	0.3510	0.0996	-0.0806	0.1912	0.1378
M'	-0.0068	0.0041	0.0023	0.0211	-0.0917	-0.9180	-0.0058	-0.0001	0.0129	-0.2038

*This derivative was transcribed accurately from the original source but exceeds the usual range of values and should be used with due caution.

TABLE VI-3 CONCLUDED
 CH-53D STABILITY AND CONTROL DERIVATIVES -- SI UNITS
 (BODY-FIXED FRL AXIS SYSTEM)

CASE 197	100 KT			LEVEL FLIGHT			1524 M	15876 KG	MID CG	
	PHI	THETA	PSI	ALPHA	BETA	GAMMA	ΘMR	B1S	A1S	ΘTR
	-2.24	0.61	1.98	0.53	-2.00	0.00	12.50	4.17	-1.33	9.97
	XDOT	ZDOT	U0	V0	W0	VTO				
	51.44	0.00	51.41	-1.80	0.48	51.44				
	U	W	Q	V	P	R	DC	DB	DA	DP
X	-0.0389	0.0231	0.5717	-0.0042	-0.6370	-0.1096	-0.0164	0.1352	0.0019	-0.0150
Z	0.0105	-0.7150	-0.7226	-0.0225	-1.1644	1.1552	-0.9879	0.5394	0.0598	0.0095
H	0.0076	0.0103	-0.5810	-0.0050	0.1880	0.0189	0.0300	-0.0731	-0.0071	0.0028
Y	0.0092	-0.0060	-0.7925	-0.1330	-0.7238	0.5398	0.0321	-0.0104	0.1039	0.1740
L'	0.0078	0.0140	-0.9690	-0.0653	-1.6900	0.3140	0.0444	-0.0428	0.1926	0.1058
H'	-0.0055	-0.0093	0.1720	0.0260	-0.0859	-0.6740	-0.0076	0.0117	0.0116	-0.1571

CASE 198	120 KT			LEVEL FLIGHT			1524 M	15876 KG	MID CG	
	PHI	THETA	PSI	ALPHA	BETA	GAMMA	ΘMR	B1S	A1S	ΘTR
	-2.65	-0.64	2.03	-0.73	-2.00	0.00	14.62	6.56	-1.75	10.45
	XDOT	ZDOT	U0	V0	W0	VTO				
	61.73	0.00	61.69	-2.15	-0.79	61.73				
	U	W	Q	V	P	R	DC	DB	DA	DP
X	-0.0458	0.0129	-0.7181	-0.0040	-0.6523	-0.1133	-0.0369	0.1516	0.0074	-0.0038
Z	0.0299	-0.6960	-1.0964	-0.0330	-1.4717	1.2741	-0.9257	0.6056	0.0688	0.0009
H	0.0080	0.0145	-0.6500	-0.0058	0.2030	0.0204	0.0387	-0.0762	-0.0029	0.0013
Y	0.0112	-0.0017	-0.8839	-0.1510	-0.8035	0.5478	0.0394	-0.0103	0.1048	0.1791
L'	0.0090	-0.0221	-1.0400	-0.0719	-1.7100	0.2970	0.0602	-0.0517	0.1826	0.1073
H'	-0.0073	-0.0123	0.2340	0.0240	-0.1180	-0.7160	-0.0168	0.0147	0.0095	-0.1636

CASE 199	120 KT			LEVEL FLIGHT			1524 M	15876 KG	MID CG	
	PHI	THETA	PSI	ALPHA	BETA	GAMMA	ΘMR	B1S	A1S	ΘTR
	-2.98	-0.74	2.04	-0.84	-2.00	0.00	13.03	5.13	-1.50	10.05
	XDOT	ZDOT	U0	V0	W0	VTO				
	61.73	0.00	61.69	-2.15	-0.91	61.73				
	U	W	Q	V	P	R	DC	DB	DA	DP
X	-0.0441	0.0255	0.4790	-0.0039	-0.6126	-0.0889	-0.0135	0.1363	0.0062	-0.0032
Z	0.0315	-0.7810	-1.0643	-0.0301	-1.4656	1.2436	-1.1387	0.6839	0.0760	0.0013
H	0.0074	0.0120	-0.6080	-0.0061	0.2000	0.0150	0.0366	-0.0805	-0.0034	0.0018
Y	0.0107	-0.0059	-0.8138	-0.1520	-0.6405	0.6071	0.0370	-0.0115	0.1044	0.1971
L'	0.0080	0.0181	-1.0000	-0.0702	-1.5200	0.3450	0.0596	-0.0532	0.2024	0.1212
H'	-0.0051	-0.0047	0.2030	0.0292	-0.0722	-0.7920	-0.0087	0.0078	0.0107	-0.1847

TABLE VI-4
 CH-53D STABILITY AND CONTROL DERIVATIVES -- US UNITS
 (BODY-FIXED FRL AXIS SYSTEM)

CASE 182	0 KT			LEVEL FLIGHT	2000 FT	35000 LB	MID CG			
	PHI	THETA	PSI	ALPHA	BETA	GAMMA	ΘMR	BIS	AIS	ΘTR
	-3.14	5.64	-0.31	5.65	0.00	0.00	14.02	0.22	-0.89	19.56
	XDOT		ZDOT	U0	V0	W0	VT0			
	0.00		0.00	0.00	0.00	0.00	0.00			
	U	W	Q	V	P	R	DC	DB	DA	DP
X	-0.0917	0.0240	0.8700	0.0029	-2.8200	-0.3780	0.6293	1.5194	0.0974	-0.0076
Z	0.0168	-0.2980	0.2890	-0.1660	-0.3030	3.5900	-6.3839	0.1356	0.0031	-0.0009
M	0.0060	-0.0018	-0.4990	0.0020	0.1970	0.0063	0.0018	-0.1791	-0.0077	0.0017
Y	0.0030	-0.0025	-2.7500	-0.1450	-1.9200	1.1500	0.0977	-0.1810	0.9661	1.2210
L*	0.0027	-0.0003	-0.9370	-0.0310	-1.9000	0.2100	-0.0379	-0.0785	0.5154	0.2296
N*	-0.0008	0.0003	0.0870	0.0027	-0.1000	-0.3400	0.0831	-0.0047	0.0325	-0.3517

CASE 183	20 KT			LEVEL FLIGHT	2000 FT	35000 LB	MID CG			
	PHI	THETA	PSI	ALPHA	BETA	GAMMA	ΘMR	BIS	AIS	ΘTR
	-2.65	4.55	-0.21	4.55	0.00	0.00	13.39	1.87	-0.93	16.73
	XDOT		ZDOT	U0	V0	W0	VT0			
	33.76		0.00	33.65	-0.00	2.68	33.76			
	U	W	Q	V	P	R	DC	DB	DA	DP
X	-0.0216	0.0336	1.8607	0.0012	-2.6300	-0.3190	0.4081	1.4557	0.0867	-0.0084
Z	-0.1430	-0.3750	-0.2996	-0.0167	-0.8650	3.2900	-6.2659	0.7622	0.0974	0.0014
M	0.0016	-0.0016	-0.3600	-0.0011	0.2030	0.0030	0.0289	-0.1869	-0.0084	0.0016
Y	0.0377	0.0033*	-3.4200	-0.1780	-1.9787	1.4096	0.0380	-0.2327	0.9487	1.1490
L*	0.0092	0.0014	-1.0700	-0.0354	-1.5200	0.2420	-0.0269	-0.0913	0.5108	0.2159
N*	-0.0107	-0.0021	0.0923	0.0103	-0.1340	-0.4770	0.0921	0.0159	0.0320	-0.3308

CASE 184	30 KT			LEVEL FLIGHT	2000 FT	35000 LB	MID CG			
	PHI	THETA	PSI	ALPHA	BETA	GAMMA	ΘMR	BIS	AIS	ΘTR
	-2.27	3.61	-0.14	3.61	0.00	0.00	12.64	1.27	-0.96	14.13
	XDOT		ZDOT	U0	V0	W0	VT0			
	50.63		0.00	50.53	-0.00	3.19	50.63			
	U	W	Q	V	P	R	DC	DB	DA	DP
X	-0.0160	0.0434	1.8607	-0.0001	-2.5000	-0.1780	0.0512	1.3690	0.0685	-0.0554
Z	-0.1740	-0.4740	0.0063	-0.0140	-1.1300	3.0900	-6.2743	1.2307	0.1470	0.0087
M	0.0065	-0.0043	-0.3250	-0.0007	0.1850	-0.0109	0.0611	-0.1760	-0.0080	0.0025
Y	0.0935	-0.0073	-3.1200	-0.1250	-2.2927	1.4117	0.1203	-0.2218	0.8905	1.0451
L*	0.0025	-0.0000	-1.0000	-0.0266	-1.5400	0.2610	0.0099	-0.0800	0.5054	0.2214
N*	-0.0011	-0.0005	0.1010	0.0084	-0.0990	-0.4970	0.0393	0.0027	0.0310	-0.3371

*This derivative was transcribed accurately from the original source but exceeds the usual range of values and should be used with due caution.

TABLE VI-4 CONTINUED
 CH-53D STABILITY AND CONTROL DERIVATIVES -- US UNITS
 (BODY-FIXED FRL AXIS SYSTEM)

CASE 185	40 KT			LEVEL FLIGHT	2000 FT	35000 LB	MID CG			
	PHI	THETA	PSI	ALPHA	BETA	GAMMA	QMR	B1S	A1S	QTR
	-1.88	2.69	-0.09	2.69	0.00	0.00	11.86	0.36	-1.01	12.71
	XDOT	ZDOT	U0	V0	W0	VT0				
	67.51	0.00	67.44	-0.00	3.17	67.51				
	U	W	Q	V	P	R	DC	DB	DA	DP
X	-0.0152	0.0264	2.0602	0.0000	-2.3890	-0.1920	0.1071	1.3434	0.0724	-3.0097
Z	-0.1660	-0.5720	0.1321	-0.0121	-1.3030	2.9700	-6.5181	1.6464	0.1839	0.0005
M	0.0098	-0.0016	-0.3500	-0.0006	0.1800	3.0079	0.0232	-0.1721	-0.0074	0.0016
Y	0.0044	-0.0076	-2.8400	-0.0953	-2.4292	1.4679	0.1837	-0.1445	0.8988	1.1800
L'	0.0027	0.0000	-0.9660	-0.0176	-1.5600	0.2650	0.0175	-0.0793	0.4989	0.2214
N'	-0.0020	-0.0012	0.1680	0.0077	-0.0939	-0.5020	0.0266	0.0044	0.0286	-0.3408

CASE 186	60 KT			LEVEL FLIGHT	2000 FT	35000 LB	MID CG			
	PHI	THETA	PSI	ALPHA	BETA	GAMMA	QMR	B1S	A1S	QTR
	-1.41	2.44	-0.06	2.44	0.00	0.00	11.21	1.59	-0.97	10.97
	XDOT	ZDOT	U0	V0	W0	VT0				
	101.27	0.00	101.18	-0.00	4.31	101.27				
	U	W	Q	V	P	R	DC	DB	DA	DP
X	-0.0272	0.0295	1.9726	-0.0006	-2.2400	-0.3130	0.1075	1.1857	0.0247	-0.1294
Z	-0.0623	-0.6570	-0.6567	-0.0148	-2.0700	3.2400	-7.6958	2.6584	0.3207	0.0348
M	0.0022	0.0007	-0.4510	-0.0009	0.1800	0.0155	0.0311	-0.1740	-0.0070	0.0030
Y	0.0058	-0.0090	-2.6000	-0.1020	-2.5525	1.6267	0.1610	-0.1364	0.8627	1.2292
L'	0.0026	0.0011	-0.9460	-0.0172	-1.5800	0.2930	0.0443	-0.0839	0.4929	0.2396
N'	-0.0021	-0.0024	0.1150	0.0082	-0.0826	-0.5610	0.0084	0.0128	0.0300	-0.3608

CASE 187	80 KT			LEVEL FLIGHT	2000 FT	35000 LB	MID CG			
	PHI	THETA	PSI	ALPHA	BETA	GAMMA	QMR	B1S	A1S	QTR
	-1.31	1.47	-0.03	1.47	0.00	0.00	11.32	2.54	-0.99	10.25
	XDOT	ZDOT	U0	V0	W0	VT0				
	135.02	0.00	134.98	-0.00	3.46	135.02				
	U	W	Q	V	P	R	DC	DB	DA	DP
X	-0.0344	0.0301	2.0648	0.0004	-2.1200	-0.2890	0.0696	1.1589	0.0349	-0.0571
Z	-0.0162	-0.7370	-1.4803	-0.0188	-2.9800	3.5100	-8.5029	3.7567	0.4585	0.0248
M	0.0022	0.0021	-0.5140	-0.0013	0.1810	0.0160	0.0494	-0.1791	-0.0073	0.0028
Y	0.0060	-0.0076	-2.5100	-0.1200	-2.5668	1.8303	0.2237	-0.0995	0.8670	1.4159
L'	0.0023	0.0022	-0.9490	-0.0190	-1.5700	0.3180	0.0777	-0.0956	0.4897	0.2647
N'	-0.0017	-0.0017	0.1190	0.0080	-0.0785	-0.6450	-0.0141	0.0170	0.0288	-0.4016

TABLE VI-4 CONTINUED
 CH-53D STABILITY AND CONTROL DERIVATIVES -- US UNITS
 (BODY-FIXED FRL AXIS SYSTEM)

CASE 189		100 KT		LEVEL FLIGHT		2000 FT		35000 LB		MID CG	
	PHI	THETA	PSI	ALPHA	BETA	GAMMA	ΘMR	B1S	A1S	ΘTR	
	-2.29	0.38	1.99	0.30	-2.00	0.00	12.03	3.87	-1.35	9.65	
	XDOT		ZDOT	U0	V0	W0	VT0				
	168.78		0.00	168.68	-5.89	0.89	168.78				
	U	W	Q	V	P	R	DC	DB	DA	DP	
X	-0.0400	0.0309	1.6819	-0.0042	-2.0900	-0.3596	-0.0259	1.0850	0.0264	-0.1021	
Z	0.0143	-0.7920	-1.8758	-0.0243	-4.0304	3.8700	-9.1795	4.9726	0.5176	0.0604	
M	0.0022	0.0028	-0.5580	-0.0017	0.1910	0.0183	0.0693	-0.1838	-0.0072	0.0057	
Y	0.0094	-0.0076	-2.5800	-0.1410	-2.2729	1.8758	0.2694	-0.0944	0.8610	1.5353	
L*	0.0023	0.0042	-0.9630	-0.0200	-1.5300	0.3400	0.1209	-0.1138	0.4883	0.2888	
N*	-0.0016	-0.0024	0.1390	0.0085	-0.0701	-0.7220	-0.0231	0.0239	0.0291	-0.4346	

CASE 189		120 KT		LEVEL FLIGHT		2000 FT		35000 LB		MID CG	
	PHI	THETA	PSI	ALPHA	BETA	GAMMA	ΘMR	B1S	A1S	ΘTR	
	-3.01	-1.10	2.06	-1.21	-2.00	0.00	13.34	5.42	-1.66	9.99	
	XDOT		ZDOT	U0	V0	W0	VT0				
	202.54		0.00	202.37	-7.07	-4.26	202.54				
	U	W	Q	V	P	R	DC	DB	DA	DP	
X	-0.0469	0.0258	1.5373	-0.0053	-2.1000	-0.3716	-0.1316	1.1049	0.0407	-0.0728	
Z	0.0353	-0.8300	-2.9689	-0.0337	-5.1084	4.3400	-9.6961	6.0604	0.6643	0.0847	
M	0.0023	0.0037	-0.6060	-0.0019	0.2060	0.0193	0.0923	-0.1931	-0.0076	0.0097	
Y	0.0113	-0.0067	-2.7700	-0.1630	-2.0873	1.9689	0.3058	-0.1064	0.8658	1.6410	
L*	0.0025	0.0060	-1.0200	-0.0219	-1.4800	0.3490	0.1615	-0.1395	0.4892	0.3125	
N*	-0.0018	-0.0014	0.1840	0.0090	-0.0676	-0.8060	-0.0230	0.0249	0.0288	-0.4665	

CASE 190		140 KT		LEVEL FLIGHT		2000 FT		35000 LB		MID CG	
	PHI	THETA	PSI	ALPHA	BETA	GAMMA	ΘMR	B1S	A1S	ΘTR	
	-3.88	-2.89	2.20	-3.03	-2.00	0.00	15.45	7.58	-2.16	10.86	
	XDOT		ZDOT	U0	V0	W0	VT0				
	236.29		0.00	235.82	-8.25	-12.49	236.29				
	U	W	Q	V	P	R	DC	DB	DA	DP	
X	-0.0540	0.0162	1.3186	-0.0055	-2.1700	-0.2535	-0.2406	1.1302	0.1199	0.1567	
Z	0.0494	-0.8610	-4.5188	-0.0457	-6.2565	4.8900	-9.7882	6.8762	0.7958	0.0404	
M	0.0023	0.0045	-0.6560	-0.0021	0.2340	0.0173	0.1219	-0.2117	-0.0091	0.0121	
Y	0.0137	-0.0037	-3.0900	-0.1860	-1.6186	2.1189	0.3760	-0.1220	0.8983	1.7768	
L*	0.0030	0.0088	-1.1900	-0.0239	-1.4300	0.3490	0.2133	-0.1760	0.4938	0.3353	
N*	-0.0021	0.0004	0.2570	0.0097	-0.0773	-0.9060	-0.0205	0.0222	0.0276	-0.5021	

TABLE VI-4 CONTINUED
CH-53D STABILITY AND CONTROL DERIVATIVES -- US UNITS
(BODY-FIXED FRL AXIS SYSTEM)

CASE 191		150 KT	LEVEL FLIGHT	2000 FT	35000 LB	MID CG				
PHI	THETA	PSI	ALPHA	BETA	GAMMA	ΘMR	BIS	AIS	ΘTR	
-4.44	-3.85	2.30	-4.02	-2.00	0.00	16.93	8.97	-2.50	11.52	
XDOT		ZDOT	U0	V0	W0	VT0				
253.17		0.00	252.40	-8.84	-17.72	253.17				
U	W	Q	V	P	R	DC	DB	DA	DP	
X	-0.0601	0.0069	1.4375	-0.0050	-2.2400	-0.2245	-0.3511	1.4720	0.1489	0.2205
Z	0.0578	-0.8530	-5.5953	-0.0562	-6.8555	5.0200	-9.6727	7.0394	0.8356	-0.0849
M	0.0025	0.0049	-0.7020	-0.0026	0.2440	0.0123	0.1301	-0.2300	-0.0140	-0.0008
Y	0.0154	-0.0014	-3.2800	-0.1980	-1.3875	2.1958	0.4165	-0.1239	0.9329	1.8779
L*	0.0033	0.0104	-1.1700	-0.0251	-1.4200	0.3500	0.2396	-0.1989	0.4992	0.3481
N*	-0.0025	0.0001	0.2600	0.0100	-0.0997	-0.9750	-0.0206	0.0104	0.0223	-0.5385

CASE 192		100 KT	LEVEL FLIGHT	2000 FT	33500 LB	MID CG				
PHI	THETA	PSI	ALPHA	BETA	GAMMA	ΘMR	BIS	AIS	ΘTR	
-2.42	0.31	1.99	0.23	-2.00	0.00	11.80	3.73	-1.29	9.48	
XDOT		ZDOT	U0	V0	W0	VT0				
168.78		0.00	168.68	-5.89	0.66	168.78				
U	W	Q	V	P	R	DC	DB	DA	DP	
X	-0.0407	0.0366	1.8445	-0.0032	-2.0400	-0.3296	0.0754	1.0998	0.0506	-0.0136
Z	0.0170	-0.8360	-1.9769	-0.0251	-4.1804	3.9000	-9.6322	5.1824	0.5212	0.0117
M	0.0021	0.0025	-0.5510	-0.0017	0.1850	0.0167	0.0640	-0.1814	-0.0082	0.0022
Y	0.0095	-0.0082	-2.5700	-0.1460	-2.4145	1.9769	0.2756	-0.0928	0.8620	1.6046
L*	0.0021	0.0039	-0.9350	-0.0195	-1.4900	0.3410	0.1171	-0.1127	0.4800	0.2888
N*	-0.0015	-0.0020	0.1260	0.0085	-0.0672	-0.7220	-0.0267	0.0173	0.0264	-0.4437

CASE 193		100 KT	LEVEL FLIGHT	2000 FT	42900 LB	MID CG				
PHI	THETA	PSI	ALPHA	BETA	GAMMA	ΘMR	BIS	AIS	ΘTR	
-1.94	0.93	1.97	0.86	-2.00	0.00	13.08	4.55	-1.57	10.34	
XDOT		ZDOT	U0	V0	W0	VT0				
168.78		0.00	168.66	-5.89	2.53	168.78				
U	W	Q	V	P	R	DC	DB	DA	DP	
X	-0.0383	0.0165	2.2201	-0.0032	-2.1300	-0.3096	-0.1862	1.2257	0.0465	-0.0159
Z	0.0057	-0.6320	-2.2592	-0.0239	-3.5104	3.6100	-7.2188	3.9315	0.4330	0.0191
M	0.0028	0.0036	-0.6110	-0.0016	0.2150	0.0186	0.0814	-0.2028	-0.0080	0.0026
Y	0.0092	-0.0049	-2.6500	-0.1240	-2.6271	1.5592	0.2407	-0.0963	0.8600	1.2875
L*	0.0031	0.0051	-1.1200	-0.0023	-1.7400	0.3360	0.1302	-0.1204	0.5239	0.2907
N*	-0.0021	-0.0046	0.1960	0.0083	-0.1070	-0.7390	-0.0303	0.0356	0.0281	-0.4446

TABLE VI-4 CONTINUED
 CH-53D STABILITY AND CONTROL DERIVATIVES -- US UNITS
 (BODY-FIXED FRL AXIS SYSTEM)

CASE 194	100 KT		LEVEL FLIGHT		2000 FT	35000 LB	FWD CG			
	PHI	THETA	PSI	ALPHA	BETA	GAMMA	ΘMR	B1S	A1S	ΘTR
	-2.23	-1.47	2.06	-1.55	-2.00	0.00	12.13	2.20	-1.54	9.57
	XDOT	ZDOT	UO	VO	WO	VT0				
	168.78	0.00	168.62	-5.89	-4.56	168.78				
	U	W	Q	V	P	R	DC	DB	DA	DP
X	-0.0396	0.0088	1.6503	-0.0041	-2.2200	-0.1796	-0.2928	1.3006	0.0656	-0.0185
Z	-0.0066	-0.9100	-2.3165	-0.0229	-3.7204	4.0000	-9.1068	4.8483	0.5040	0.0160
M	0.0022	-0.0000	-0.5650	-0.0018	0.1810	0.0211	0.0460	-0.1737	-0.0070	0.0026
Y	0.0090	-0.0093	-2.6100	-0.1430	-2.3703	1.9165	0.2458	-0.1006	0.8644	1.5062
L*	0.0026	0.0042	-0.9770	-0.0197	-1.5400	0.3430	0.1179	-0.1134	0.4890	0.2879
N*	-0.0017	-0.0025	0.2580	0.0097	-0.0626	-0.7470	-0.0288	0.0227	0.0217	-0.4510

CASE 195	100 KT		LEVEL FLIGHT		2000 FT	35000 LB	AFT CG			
	PHI	THETA	PSI	ALPHA	BETA	GAMMA	ΘMR	B1S	A1S	ΘTR
	-2.49	4.03	1.83	3.95	-2.00	0.00	11.90	7.27	-0.95	9.90
	XDOT	ZDOT	UO	VO	WO	VT0				
	168.78	0.00	168.28	-5.89	11.61	168.78				
	U	W	Q	V	P	R	DC	DB	DA	DP
X	-0.0456	0.0749	1.8007	-0.0037	-1.7900	-0.6696	0.5597	0.6861	-0.0317	-0.2014
Z	0.0530	-0.7920	-1.0781	-0.0268	-4.6004	3.5300	-9.1461	5.0270	0.5418	0.1321
M	0.0018	0.0072	-0.5390	-0.0014	0.2180	0.0162	0.1182	-0.2028	-0.0077	0.0149
Y	0.0099	-0.0037	-2.4800	-0.1380	-2.0607	1.8781	0.4082	-0.0149	0.8992	1.7622
L*	0.0016	0.0032	-0.9440	-0.0202	-1.4800	0.3310	0.1283	-0.1185	0.4837	0.2907
N*	-0.0013	-0.0020	-0.0948*	0.0064	-0.0826	-0.6650	-0.0070	0.0296	0.0486	-0.3927

CASE 196	150 KT		LEVEL FLIGHT		2000 FT	35000 LB	AFT CG			
	PHI	THETA	PSI	ALPHA	BETA	GAMMA	ΘMR	B1S	A1S	ΘTR
	-4.68	-0.32	2.03	-0.49	-2.00	0.00	16.42	12.03	-2.04	11.71
	XDOT	ZDOT	UO	VO	WO	VT0				
	253.17	0.00	253.01	-8.84	-2.16	253.17				
	U	W	Q	V	P	R	DC	DB	DA	DP
X	-0.0652	0.0584	1.6567	0.0005	-1.5700	-6.4944	0.5000	0.9590	0.1521	0.4437
Z	0.0967	-0.8260	-4.4080	-0.0587	-7.6056	4.4600	-10.1244	7.3579	0.8055	-0.1913
M	0.0016	0.0100	-0.6570	-0.0019	0.2820	0.0038	0.1764	-0.2591	-0.0192	0.0016
Y	0.0152	0.0031*	-3.0600	-0.1910	-0.9667	2.1080	0.5475	-0.0750	0.9186	2.0447
L*	0.0199	0.0098	-1.1100	-0.0256	-1.3000	0.3510	0.2529	-0.2047	0.4856	0.3499
N*	-0.0021	0.0012	0.0023	0.0064	-0.0917	-0.9180	-0.0148	-0.0003	0.0327	-0.5175

* This derivative was transcribed accurately from the original source but exceeds the usual range of values and should be used with due caution.

TABLE VI-4 CONCLUDED
CH-53D STABILITY AND CONTROL DERIVATIVES -- US UNITS
(BODY-FIXED FRL AXIS SYSTEM)

CASE 197	100 KT			LEVEL FLIGHT			5000 FT	35000 LB	MID CG	
	PHI	THETA	PSI	ALPHA	BETA	GAMMA	ΘMR	B1S	A1S	ΘTR
	-2.24	0.61	1.98	0.53	-2.00	0.00	12.50	4.17	-1.33	9.97
	XDOT	ZDOT	UO	VO	WO	VTO				
	168.78	0.00	168.67	-5.89	1.57	168.78				
	U	W	Q	V	P	R	DC	DB	DA	DP
X	-0.0389	0.0231	1.8757	-0.0042	-2.0900	-0.3596	-0.1365	1.1270	0.0160	-0.1248
Z	0.0105	-0.7150	-2.3709	-0.0225	-3.9204	3.7900	-8.2325	4.4948	0.4982	0.0794
M	0.0023	0.0031	-0.5810	-0.0015	0.1880	0.0189	0.0761	-0.1857	-0.0180	0.0071
Y	0.0092	-0.0060	-2.6000	-0.1330	-2.3747	1.7709	0.2673	-0.0870	0.8658	1.4497
L'	0.0024	0.0043	-0.9690	-0.0199	-1.6900	0.3140	0.1129	-0.1088	0.4892	0.2688
N'	-0.0017	-0.0028	0.1720	0.0079	-0.3859	-0.6740	-0.0193	0.0297	0.0295	-0.3991

CASE 198	120 KT			LEVEL FLIGHT			5000 FT	35000 LB	MID CG	
	PHI	THETA	PSI	ALPHA	BETA	GAMMA	ΘMR	B1S	A1S	ΘTR
	-2.65	-0.64	2.03	-0.73	-2.00	0.00	14.62	6.56	-1.75	10.45
	XDOT	ZDOT	UO	VO	WO	VTO				
	202.54	0.00	202.40	-7.07	-2.59	202.54				
	U	W	Q	V	P	R	DC	DB	DA	DP
X	-0.0458	0.0129	2.3560	-0.0040	-2.1400	-0.3716	-0.3072	1.2634	0.0620	0.0319
Z	0.0299	-0.6960	-3.5972	-0.0330	-4.8284	4.1800	-7.7140	5.0464	0.5737	0.0072
M	0.0024	0.0044	-0.6500	-0.0018	0.2030	0.0204	0.0983	-0.1935	-0.0075	0.0033
Y	0.0112	-0.0017	-2.9000	-0.1510	-2.6360	1.7972	0.3282	-0.0859	0.8733	1.4925
L'	0.0027	-0.0067	-1.0400	-0.0219	-1.7100	0.2970	0.1529	-0.1313	0.4638	0.2724
N'	-0.0022	-0.0038	0.2340	0.0073	-0.1180	-0.7160	-0.0427	0.0373	0.0241	-0.4155

CASE 199	120 KT			LEVEL FLIGHT			5000 FT	35000 LB	MID CG	
	PHI	THETA	PSI	ALPHA	BETA	GAMMA	ΘMR	B1S	A1S	ΘTR
	-2.98	-0.74	2.04	-0.84	-2.00	0.00	13.03	5.13	-1.50	10.05
	XDOT	ZDOT	UO	VO	WO	VTO				
	202.54	0.00	202.39	-7.07	-2.98	202.54				
	U	W	Q	V	P	R	DC	DB	DA	DP
X	-0.0441	0.0255	1.5714	-0.0039	-2.0100	-0.2916	-0.1125	1.1359	0.0516	-0.0263
Z	0.0315	-0.7810	-3.4919	-0.0301	-4.8084	4.0800	-9.4892	5.6991	0.6336	0.0112
M	0.0023	0.0036	-0.6080	-0.0018	0.2000	0.0150	0.0929	-0.2043	-0.0087	0.0045
Y	0.0107	-0.0059	-2.6700	-0.1520	-2.1014	1.9919	0.3087	-0.0956	0.8702	1.6428
L'	0.0024	0.0056	-1.0900	-0.0214	-1.6200	0.3450	0.1511	-0.1152	0.5142	0.3080
N'	-0.0015	-0.0014	0.2030	0.0089	-0.0722	-0.7920	-0.0221	0.0197	0.0271	-0.4692

TABLE VI-5
CH-53D TRANSFER FUNCTION FACTORS
CASE 182 HOVER AFCS OFF

DENOMINATOR: (0) (-.290) (.320) (.891) (2.03) [-.216; .472] [-.0377; .667] <-.0167>

CONTROL NUMERATORS:

PHI/DA .519 (0) (.0737) (.303) (.369) (.822) [-.236; .475] <.000792>
THE/DB -.179 (0) (.0414) (.278) (.332) (2.23) [-.0451; .665] <-.000675>
PSI/DP -.353 (.308) (.879) (2.10) [-.218; .473] [-.0664; .652] <-.0191>

PHI/DB -.0780 (0) (.313) (-1.56) [-.825; .0908] [.834; .308] <.297E-4>
PHI/DP .195 (0) (.0730) (.311) (-.506) (.828) [-.211; .481] <-.000429>
PHI/DC -.0298 (0) (.300) (.647) [-.647; .193] [-.215; .715] <-.000110>

THE/DA .0900 (0) (.0760) (.272) (.517) [-.0572; .613] <.000362>
THE/DP -.0176 (0) [.899; .152] [.152; .603] [-.0110; 1.08] <-.000172>
THE/DC .00632 (0) (.0846) (.284) [-.0381; .664] [.774; 2.51] <.000423>

PSI/DA .0330 (.303) [-.226; .478] [.982; 1.07] [-.360; 1.32] <.00455>
PSI/DB .00510 (.309) (-2.96) (3.21) [-.382; .553] [.571; .613] <-.00172>
PSI/DC .0832 (.297) (.855) (2.08) [-.237; .473] [-.0471; .672] <.00445>

XD/DB 1.53 (0) (.276) (.333) (2.29) [-.0411; .669] [.101; 1.91] <.525>
YD/DA .964 (0) (.827) [-.000; .325] [-.238; .475] [.110; 4.14] <.325>
ZD/DC -6.41 (0) (.282) (.902) (2.02) [-.228; .468] [-.0421; .670] <-.324>

XD/DC .0717 (0) (.284) (-5.68) [-.0394; .666] [.718; 1.76] <-.159>
YD/DP 1.22 (0) (.321) (-.365) (.819) [-.208; .481] [.376; 2.38] <-.154>
ZD/DB -.00473 (0) (.392) [-.0349; .210] [-.330; 1.60] [.998; 8.24] <-.0142>

PHI/DA ; THE/DB -.0933 (0) (.0431) (.0735) (.283) (.390) <-.327E-4>
PHI/DA ; PSI/DP -.189 (.0739) (.303) (.823) [-.234; .475] <-.000788>
THE/DB ; PSI/DP .0633 (.0406) (.304) (2.29) [-.0747; .650] <.000754>

PHI/DB ; PSI/DP .0265 (.247) (.296) (-1.52) [-.492; .163] <-.783E-4>
PHI/DP ; THE/DB -.0363 (0) (.0435) (.0709) (.306) (-.516) <.177E-4>
PHI/DC ; THE/DB .00582 (0) (.0358) (.268) [-.703; .257] <.370E-5>

THE/DA ; PSI/DP -.0328 (.0712) (.453) [-.0836; .589] <-.000367>
THE/DP ; PHI/DA -.00798 (0) (.0287) (.0738) (-.0882) (.755) <.112E-5>
THE/DC ; PHI/DA .00310 (0) (.0752) (.103) (.323) (2.88) <.224E-4>

PSI/DA ; THE/DB -.00588 (.0368) (.286) (1.50) [-.375; 1.26] <-.000147>
PSI/DB ; PHI/DA .00522 (.0978) (.303) (-2.50) [.117; .482] <-.898E-4>
PSI/DC ; THE/DB -.0149 (.0348) (.269) (2.27) [-.0608; .657] <-.000137>

PSI/DC ; PHI/DA .0441 (.0988) (.303) (.782) [-.235; .483] <.000241>
XD/DB ; PHI/DA .799 (0) (.0762) (.280) (.393) [.0980; 1.94] <.0252>
XD/DB ; PSI/DP -.538 (.303) (2.34) [-.0715; .652] [.102; 1.92] <-.597>

YD/DA ; THE/DB -.174 (0) (.0405) (.285) (.367) [.107; 4.15] <-.0126>
YD/DA ; PSI/DP -.381 (.292) (.825) [-.235; .476] [.104; 3.99] <-.330>
ZD/DC ; PHI/DA -3.33 (0) (.0826) (.322) (.819) [-.237; .474] <-.0163>

ZD/DC ; THE/DB 1.15 (0) (.0421) (.287) (2.22) [-.0545; .662] <.0135>
ZD/DC ; PSI/DP 2.27 (.887) (2.11) [-.229; .469] [-.0540; .662] <.408>
XD/DC ; PHI/DA .00163 (0) (.0929) (.322) (-8.78) [-.932; 4.22] <-.00859>

XD/DC ; THE/DB -.00928 (0) (.284) (1.36) (4.32) [-.0957; .664] <-.00683>
XD/DC ; PSI/DP .0272 (1.64) [-.0743; .654] [-.0414; 3.02] <.174>
YD/DP ; PHI/DA .444 (0) (.0667) (.200) (.824) [-.229; .467] <.00106>

YD/DP ; THE/DB -.222 (0) (.0402) (.314) (-.370) [.385; 2.40] <.00598>
ZD/DB ; PHI/DA -.00706 (0) (.0324) [.223; .423] [.619; 3.22] <-.000424>
ZD/DB ; PSI/DP .0256 (5.22) [.210; .0766] [-.472; 1.43] <.00160>

PHI/DA ; THE/DB ; PSI/DP .0342 (.0429) (.0741) (.301) <.327E-4>
PHI/DC ; THE/DB ; PSI/DP .000968 (.0354) (.254) (-.886) <-.771E-5>
THE/DC ; PHI/DA ; PSI/DP -.000455 (.0720) (.102) (6.77) <-.227E-4>

TABLE VI-5 CONTINUED
CH-53D TRANSFER FUNCTION FACTORS

CASE 182 HOVER AFCS OFF

CONTROL NUMERATORS CONCLUDED:

PSI/DC ; PHI/DA ; THE/DB - .00798 (.0349) (.0988) (.270) <-.742E-5>
 XD/DB ; PHI/DA ; PSI/DP - .292 (.0768) (.300) [-.0999; 1.94] <-.0253>
 YD/DA ; THE/DB ; PSI/DP .0687 (.0403) (.290) [.103; 3.99] <.0128>
 ZD/DC ; PHI/DA ; THE/DB .599 (0) (.0427) (.0833) (.321) <.000684>
 ZD/DC ; THE/DB ; PSI/DP - .407 (.0407) (2.29) [-.0663; .653] <-.0162>
 ZD/DC ; PHI/DA ; PSI/DP 1.22 (.0856) (.825) [-.235; .475] <.0194>
 XD/DC ; PHI/DA ; THE/DB - .00511 (0) (.0893) (.316) (2.49) <-.000359>
 XD/DC ; PHI/DA ; PSI/DP .00128 (.0937) (5.00) [-.114; 3.94] <.00930>
 XD/DC ; THE/DB ; PSI/DP .000927 (3.41) (5.23) [-.0257; .641] <.00680>
 YD/DP ; PHI/DA ; THE/DB - .0803 (0) (.211) [.981; .0495] <-.415E-4>
 ZD/DB ; PHI/DA ; PSI/DP .00281 (-.158) (5.71) [.433; .545] <-.000753>
 ZD/DC ; PHI/DA ; THE/DB ; PSI/DP - .220 (.0412) (.0864) <-.000781>
 XD/DC ; PHI/DA ; THE/DB ; PSI/DP .000469 (.0898) (8.16) <.000344>

GUST NUMERATORS:

PHI/UG - .00251 (0) (0) (.285) (.325) (-1.68) [.232; .0850] <.281E-5>
 THE/UG - .00570 (0) (0) (.290) (.318) (2.23) [-.0455; .666] <-.000518>
 PSI/UG .00113 (0) (0) (.268) (.365) (2.41) [-.327; .659] <.000116>
 PHI/VG .0307 (0) (0) (.287) (.317) (.839) [-.214; .471] <.000521>
 THE/VG - .00202 (0) (0) (-.0691) (.206) (.265) [-.433; .607] <.280E-5>
 PSI/VG - .00262 (0) (0) (.302) (.808) (3.23) [-.218; .470] <-.000459>
 PHI/WG - .00116 (0) (0) (.213) (.344) (2.95) [-.108; .379] <-.359E-4>
 THE/WG .00243 (0) (0) (.0812) (.302) (2.08) [-.0493; .669] <.554E-4>
 PSI/WG - .000395 (0) (.489) (2.13) [-.228; .305] [-.530; .782] <-.233E-4>
 PHI/PG 1.88 (0) (.0948) (.303) (.369) (.898) [-.217; .467] <.00390>
 THE/PG - .189 (0) (-.169) (-.267) (-.367) (.936) [-.178; .665] <.00130>
 PSI/PG .144 (.302) (.880) (1.34) [-.222; .469] [-.393; 1.20] <.0164>
 PHI/QG .905 (0) (.0309) (.299) (.351) (.515) [-.466; .506] <.000388>
 THE/QG .494 (0) (.0775) (.286) (.337) (2.49) [-.0438; .661] <.00402>
 PSI/QG - .0967 (.301) (-.463) (2.99) [.822; .545] [-.281; .558] <.00371>
 PHI/RG - .414 (0) (0) (.0342) (.311) (.797) [-.229; .476] <-.000793>
 THE/RG - .0661 (0) (0) (.125) (.151) [-.0416; .599] <-.000449>
 PSI/RG .335 (.307) (.865) (2.17) [-.216; .471] [-.0607; .625] <.0167>
 XD/UG .0897 (0) (.289) (.317) (2.22) [-.0416; .669] [.153; 1.43] <.0167>
 ZD/UG .00395 (0) (0) (0) (.300) (-.822) (2.98) [.243; 1.47] <-.00625>
 YD/VG .155 (0) (.285) (.320) (.831) [-.214; .471] [-.296; 2.53] <.0167>
 XD/WG - .00413 (0) (0) (.302) (2.13) [-.0397; .671] [-.0876; 4.29] <-.0219>
 ZD/WG .290 (0) (.302) (.918) (2.02) [-.201; .467] [-.0578; .685] <.0167>
 PHI/UG ; THE/DB - .534E-4 (0) (0) (-.0498) (.305) <.811E-6>
 PHI/UG ; PSI/DP .000663 (0) (.304) (-2.03) [.191; .0887] <-.321E-5>
 THE/UG ; PHI/DA - .00297 (0) (0) (.0737) (.298) (.378) <-.247E-4>
 THE/UG ; PSI/DP .00203 (0) (.304) (2.27) [-.0747; .650] <.000593>
 PSI/UG ; PHI/DA .000671 (0) (-.166) (.303) [.264; .151] <-.766E-6>
 PSI/UG ; THE/DB - .000174 (0) (.305) (2.24) [-.0674; .672] <-.535E-4>
 PHI/VG ; THE/DB - .00566 (0) (0) (.0414) (.277) (.324) <-.211E-4>
 PHI/VG ; PSI/DP - .0103 (0) (.309) (.838) [-.215; .472] <-.000596>
 THE/VG ; PHI/DA - .000865 (0) (0) (.0761) (.271) (.626) <-.112E-4>
 THE/VG ; PSI/DP .000665 (0) (-.0812) (.193) [-.570; .553] <-.320E-5>
 PSI/VG ; PHI/DA - .00237 (0) (.303) (.844) [-.224; .484] <-.000142>
 PSI/VG ; THE/DB .000480 (0) (.286) (3.23) [.634; .0255] <.289E-6>

TABLE VI-5 CONTINUED
CH-53D TRANSFER FUNCTION FACTORS

CASE 182 HOVER AFCS OFF

GUST NUMERATORS CONTINUED:

PHI/WG ; THE/DB	.000397 (0) (0) (.0383) (.181) (.492) <.135E-5>
PHI/WG ; PSI/DP	.000486 (0) (.245) (2.31) [-.118; .383] <.405E-4>
THE/WG ; PHI/DA	.00125 (0) (0) (.0755) (.0958) (.377) <.341E-5>
THE/WG ; PSI/DP	-.000863 (0) (-.0814) (2.12) [-.0793; .654] <-.636E-4>
PSI/WG ; PHI/DA	-.000166 (0) (.301) (-1.04) [-.0840; .410] <-.869E-5>
PSI/WG ; THE/DB	.583E-4 (0) (.0710) (1.87) [-.263; .927] <.666E-5>
PHI/PG ; THE/DB	-.352 (0) (.0433) (.0922) (.284) (.400) <-.000160>
PHI/PG ; PSI/DP	-.693 (.100) (.302) (.879) [-.216; .468] <-.00404>
THE/PG ; PHI/DA	-.0870 (0) (.0341) (.0719) (.294) (.369) <-.231E-4>
THE/PG ; PSI/DP	.0693 (.161) (-.313) (.876) [-.233; .654] <-.00131>
PSI/PG ; PHI/DA	.0127 (.303) (.368) (-1.18) [-.0322; .413] <-.000285>
PSI/PG ; THE/DB	-.0249 (.0334) (.287) (1.57) [-.366; 1.19] <-.000530>
PHI/QG ; THE/DB	-.123 (0) (.255) (.339) [.850; .0463] <-.229E-4>
PHI/QG ; PSI/DP	-.300 (.0261) (.304) (.564) [-.449; .509] <-.000348>
THE/QG ; PHI/DA	.262 (0) (.0754) (.0817) (.312) (.363) <.000182>
THE/QG ; PSI/DP	-.176 (.0771) (.319) (2.53) [-.0723; .645] <-.00456>
PSI/QG ; PHI/DA	-.0800 (-.0629) (.303) (.421) [-.332; .332] <.706E-4>
PSI/QG ; THE/DB	.0148 (.135) (.358) (2.94) [-.138; .355] <.000265>
PHI/RG ; THE/DB	.0744 (0) (0) (.303) [.991; .0382] <.329E-4>
PHI/RG ; PSI/DP	.0808 (.0951) (.321) (.746) [-.237; .483] <.000429>
THE/RG ; PHI/DA	.00313 (0) (0) (-.0173) (.0755) <-.409E-5>
THE/RG ; PSI/DP	.00444 (5.39) [.824; .138] [-.0456; .613] <.000173>
PSI/RG ; PHI/DA	.187 (-.0761) (.303) (.813) [-.236; .475] <.000792>
PSI/RG ; THE/DB	-.0600 (.0413) (.300) (2.33) [-.0635; .623] <-.000675>
XD/UG ; PHI/DA	.0468 (0) (.0734) (-.296) (.381) [.153; 1.43] <.000792>
XD/UG ; THE/DB	-.00736 (0) (.269) (.344) (2.23) [-.0484; .666] <-.000675>
XD/UG ; PSI/DP	-.0317 (.303) (2.26) [-.0717; .652] [.153; 1.44] <-.0191>
ZD/UG ; PHI/DA	.00190 (0) (0) (-.128) (.166) (-.341) (1.72) <.237E-4>
ZD/UG ; THE/DB	-.000733 (0) (0) (.809) (2.29) [.0651; .570] <-.000442>
ZD/UG ; PSI/DP	-.00132 (0) (0) (-1.17) (2.78) [.0278; 1.38] <.00813>
YD/VG ; PHI/DA	.0506 (0) (.829) [.992; .293] [-.230; .468] <.000792>
YD/VG ; THE/DB	-.0281 (0) (.0414) (.277) (.326) [.306; 2.54] <-.000675>
YD/VG ; PSI/DP	-.0514 (.311) (.830) [-.215; .472] [.289; 2.54] <-.0191>
XD/WG ; PHI/DA	-.00203 (0) (0) (.0904) (.377) [-.0141; 4.45] <-.00137>
XD/WG ; THE/DB	-.00296 (0) (0) (.302) (2.35) [-.00776; .638] <-.000856>
XD/WG ; PSI/DP	.00145 (0) (2.13) [-.0714; .655] [-.0995; 4.35] <.0251>
ZD/WG ; PHI/DA	.151 (0) (.0755) (-.380) (.811) [-.233; .476] <.000792>
ZD/WG ; THE/DB	-.0520 (0) (.0415) (.305) (2.23) [-.0454; .679] <-.000675>
ZD/WG ; PSI/DP	-.103 (.908) (2.10) [-.202; .466] [-.0864; .670] <-.0191>
XD/UG ; ZD/DC	-.575 (0) (.283) (2.22) [-.0517; .663] [.153; 1.43] <-.324>
YD/VG ; ZD/DC	-.947 (0) (.279) (.849) [-.222; .470] [.294; 2.56] <-.324>
PHI/UG ; THE/DB ; PSI/DP	.339E-4 (0) (-.223) (.305) <-.231E-5>
THE/UG ; PHI/DA ; PSI/DP	.00110 (0) (.0738) (.303) <.246E-4>
PSI/UG ; PHI/DA ; THE/DB	-.908E-4 (0) (.100) (.304) <-.277E-5>
PHI/VG ; THE/DB ; PSI/DP	.00190 (0) (.0407) (.304) <.236E-4>
THE/VG ; PHI/DA ; PSI/DP	.000280 (0) (.0711) (.569) <.113E-4>
PSI/VG ; PHI/DA ; THE/DB	.000436 (0) (.0369) (.286) <.460E-5>
PHI/WG ; THE/DB ; PSI/DP	-.000152 (0) (.0359) (.245) <-.134E-5>
THE/WG ; PHI/DA ; PSI/DP	-.000460 (0) (.0720) (.103) <-.341E-5>
PSI/WG ; PHI/DA ; THE/DB	.174E-4 (0) (-.0290) (-.0559) <.282E-7>

TABLE VI-5 CONTINUED
CH-53D TRANSFER FUNCTION FACTORS

CASE 182 HOVER AFCS OFF

GUST NUMERATORS CONCLUDED:

PHI/PG ; THE/DB ; PSI/DP	.130 (.0433) (.0981) (.300) <.000165>
THE/PG ; PHI/DA ; PSI/DP	.0320 (.0338) (.0763) (.284) <.234E-4>
PSI/PG ; PHI/DA ; THE/DB	-.00140 (.0448) (.290) (-.501) <.913E-5>
PHI/QG ; THE/DB ; PSI/DP	.0406 (.301) [.833; .0516] <.325E-4>
THE/QG ; PHI/DA ; PSI/DP	-.0969 (.0724) (.0864) (.300) <-.000182>
PSI/QG ; PHI/DA ; THE/DB	.0118 (.300) [.863; .0710] <.178E-4>
PHI/RG ; THE/DB ; PSI/DP	-.0141 (.0430) (.0932) (.311) <-.177E-4>
THE/RG ; PHI/DA ; PSI/DP	.00299 (.0379) (.0766) (-.129) <-.112E-5>
PSI/RG ; PHI/DA ; THE/DB	-.0337 (.0430) (.0761) (.297) <-.327E-4>
XD/UG ; PHI/DA ; THE/DB	-.00384 (0) (.0787) (.268) (.405) <-.327E-4>
XD/UG ; PHI/DA ; PSI/DP	-.0171 (.0735) (.304) [.154; 1.44] <-.000788>
XD/UG ; THE/DB ; PSI/DP	.00258 (.303) (2.27) [-.0741; .652] <.000754>
ZD/UG ; PHI/DA ; THE/DB	-.000382 (0) (0) (.0330) (1.12) <-.142E-4>
ZD/UG ; PHI/DA ; PSI/DP	-.000664 (0) (-.143) (.495) (-.714) <-.336E-4>
ZD/UG ; THE/DB ; PSI/DP	.000248 (0) (2.12) [-.321; .308] <.498E-4>
YD/VG ; PHI/DA ; THE/DB	-.00913 (0) (.0417) [.998; .293] <-.327E-4>
YD/VG ; PHI/DA ; PSI/DP	-.0164 (.264) (.826) [-.229; .469] <-.000788>
YD/VG ; THE/DB ; PSI/DP	.00932 (.0406) (.306) [.299; 2.55] <.000754>
XD/WG ; PHI/DA ; THE/DB	-.00156 (0) (0) (.0887) (.374) <-.518E-4>
XD/WG ; PHI/DA ; PSI/DP	.000734 (0) (.0941) [-.0141; 4.49] <.00139>
XD/WG ; THE/DB ; PSI/DP	.00106 (0) (2.43) [-.0471; .623] <.000997>
ZD/WG ; PHI/DA ; THE/DB	-.0271 (0) (.0431) (.0755) (.371) <-.327E-4>
ZD/WG ; PHI/DA ; PSI/DP	-.0550 (.0768) (.827) [-.232; .475] <-.000788>
ZD/WG ; THE/DB ; PSI/DP	.0184 (.0406) (2.29) [-.0740; .663] <.000754>
XD/UG ; ZD/DC ; PHI/DA	-.300 (0) (.0825) (.322) [.154; 1.43] <-.0163>
XD/UG ; ZD/DC ; THE/DB	.0472 (0) (.292) (2.22) [-.0572; .662] <.0135>
XD/UG ; ZD/DC ; PSI/DP	.203 (2.26) [-.0637; .655] [.153; 1.44] <.408>
YD/VG ; ZD/DC ; PHI/DA	-.306 (0) (.290) (.833) [-.234; .469] <-.0163>
YD/VG ; ZD/DC ; THE/DB	.172 (0) (.0421) (.282) [.304; 2.57] <.0135>
YD/VG ; ZD/DC ; PSI/DP	.332 (.846) [-.223; .471] [.290; 2.56] <.408>
XD/UG ; PHI/DA ; THE/DB ; PSI/DP	.00139 (.0793) (.297) <.327E-4>
ZD/UG ; PHI/DA ; THE/DB ; PSI/DP	.000136 (0) (-.162) <-.221E-4>
YD/VG ; PHI/DA ; THE/DB ; PSI/DP	.00297 (.0415) (.265) <.327E-4>
XD/WG ; PHI/DA ; THE/DB ; PSI/DP	.000575 (0) (.0901) <.518E-4>
ZD/WG ; PHI/DA ; THE/DB ; PSI/DP	.00992 (.0426) (.0774) <.327E-4>
XD/UG ; ZD/DC ; PHI/DA ; THE/DB	.0246 (0) (.0854) (.325) <.000684>
YD/VG ; ZD/DC ; PHI/DA ; THE/DB	.0553 (0) (.0423) (.293) <.000684>
YD/VG ; ZD/DC ; PHI/DA ; PSI/DP	.106 (.830) [-.235; .470] <.0194>
XD/WG ; ZD/DC ; PHI/DA ; THE/DB	.0115 (0) (.0894) (.349) <.000359>
XD/UG ; ZD/DC ; PHI/DA ; THE/DB ; PSI/DP	-.00893 (.0875) <-.000781>
YD/VG ; ZD/DC ; PHI/DA ; THE/DB ; PSI/DP	-.0191 (.0409) <-.000781>
XD/WG ; ZD/DC ; PHI/DA ; THE/DB ; PSI/DP	-.00383 (.0898) <-.000344>

TABLE VI-5 CONTINUED
CH-53D TRANSFER FUNCTION FACTORS

CASE 182 HOVER AFCS ON

DENOMINATOR: (0) (-.0730) (-.114) (-.306) (-.351) (-.714) (1.06) (2.33) (3.43) [.635;1.62]<.0142>

CONTROL NUMERATORS:

PHI/DA .519 (0) (.0742) (-.0982) (-.113) (-.301) (-.714) (2.09) [.604;1.63]<.000514>
 THE/DB -.179 (0) (.0438) (-.0709) (-.988) (1.07) (2.22) (3.82) [1.000;.329]<-.000539>
 PSI/DP -.353 (-.112) (-.556) (-.714) (1.03) (3.95) [-.997;.320] [.635;1.63]<-.0173>

PHI/DB -.0780 (0) (-.0899) (-.160) (-.301) (1.07) (-1.52) (1.96) [.951;.117]<-.148E-4>
 PHI/DP .195 (0) (-.0742) (-.114) (-.302) (-.556) (-.714) (-1.09) [.615;1.66]<-.000590>
 PHI/DC -.0298 (0) (.109) (.270) (-.714) (-1.32) [-.966;.0986] [.559;1.56]<.196E-4>

THE/DA .0885 (0) (.455) (-.714) (2.12) [.984;.0811] [-.0686;.599]<.000144>
 THE/DP -.0176 (0) (.0874) (-.473) (-.556) (-.714) [-.0336;.260] [.465;2.80]<-.000153>
 THE/DC .00632 (0) (-.361) (-.714) [-.993;.0837] [.903;1.13] [.672;4.16]<.000251>

PSI/DA .0330 (-.120) (.275) (-.551) (-.714) (1.39) [-.361;1.27] [-.556;1.68]<.00270>
 PSI/DB .00510 (.626) (1.07) (1.26) (-1.69) (9.18) [.992;.298] [.133;.512]<-.00155>
 PSI/DC .0832 (-.120) (-.251) (-.373) (-.565) (-.714) (1.02) (3.87) [-.630;1.64]<.00400>

XD/DB 1.53 (0) (-.0739) (-.316) (-.344) (-.974) (1.07) (2.20) (3.97) [-.0926;1.93]<.413>
 YD/DA .964 (0) (.290) (-.714) (2.12) [1.000;.104] [.607;1.64] [.119;4.11]<.206>
 ZD/DC -6.41 (0) (-.0727) (-.114) (-.366) (-.714) (1.03) (2.32) (3.43) [-.634;1.62]<-.298>

XD/DC .172 (0) (-.0807) (-.358) (-.714) (-.985) [-.857;1.06] [.406;2.96]<-.0346>
 YD/DP 1.22 (0) (-.112) (-.293) (-.487) (-.556) (-.714) [-.614;1.65] [.619;3.23]<-.218>
 ZD/DB -.0932 (0) (-.0819) (1.07) (2.50) (3.90) [-.575;.149] [.0804;1.56]<-.00428>

PHI/DA ;THE/DB -.0933 (0) (-.0432) (-.0724) (-.0981) (-.302) (1.07) (2.10) [-.194E-4>
 PHI/DA ;PSI/DP -.189 (-.0737) (-.116) (-.299) (-.556) (-.714) [.606;.320]<.000513>
 THE/DB ;PSI/DP .0633 (-.0410) (-.556) (-.960) (1.07) (4.24) [-.995;.320]<.000639>

PHI/DB ;PSI/DP .0265 (.247) (-.296) (-.556) (1.07) (-1.52) [-.492;.163]<-.464E-4>
 PHI/DP ;THE/DB -.0363 (0) (-.0432) (-.0725) (-.304) (-.556) (1.07) (-1.09) [-.223E-4>
 PHI/DC ;THE/DB .00582 (0) (-.0282) (-.216) (1.07) (-1.35) [-.971;.0973]<-.481E-6>

THE/DA ;PSI/DP -.0328 (-.0712) (-.453) (-.556) (-.714) [-.0836;.589]<-.000146>
 THE/DP ;PHI/DA -.00798 (0) (-.0287) (-.0738) (-.0882) (-.556) (-.714) (-.755) [-.446E-6>
 THE/DC ;PHI/DA .00310 (0) (-.0990) (-.714) [-.992;.0837] [.869;2.41]<.891E-5>

PSI/DA ;THE/DB -.00588 (-.0368) (-.286) (-.556) (1.07) (1.50) [-.375;1.26]<-.870E-4>
 PSI/DB ;PHI/DA .00522 (-.0977) (-.302) (-.799) (1.07) (-1.67) [-.300;.492]<-.533E-4>
 PSI/DC ;THE/DB -.0149 (-.0348) (-.266) (-.390) (-.556) (-.936) (1.07) (4.17) [-.000125>

PSI/DC ;PHI/DA .0441 (-.0989) (-.120) (-.250) (-.563) (-.714) [-.602;1.64]<.000141>
 XD/DB ;PHI/DA .799 (0) (-.0750) (-.0981) (-.301) (1.07) (2.10) [-.0987;1.94]<.0149>
 XD/DB ;PSI/DP -.538 (-.556) (-.946) (1.07) (4.35) [-.996;.320] [-.0942;1.93]<-.503>

YD/DA ;THE/DB -.174 (0) (-.0406) (-.0953) (-.291) (1.07) (2.12) [.117;4.12]<-.00749>
 YD/DA ;PSI/DP -.381 (-.113) (-.289) (-.556) (-.714) [-.607;1.63] [-.103;3.98]<-.209>
 ZD/DC ;PHI/DA -3.33 (0) (-.0734) (-.0985) (-.113) (-.714) (2.06) [-.605;1.63]<-.0106>

ZD/DC ;THE/DB 1.15 (0) (-.0441) (-.0705) (-.371) (-.955) (1.07) (2.21) (3.82) [-.0114>
 ZD/DC ;PSI/DP 2.27 (-.112) (-.356) (-.556) (-.714) (1.02) (3.95) [.635;1.63]<.384>
 XD/DC ;PHI/DA .0308 (0) (-.0807) (-.0988) (-.714) (-.970) [-.865;2.67]<-.00121>

XD/DC ;THE/DB -.00928 (0) (-.0857) (-.372) (-.815) (1.07) (6.45) [-.643;1.90]<-.00600>
 XD/DC ;PSI/DP .0295 (-.340) (-.556) (-.714) [-.000;1.57] [-.864;2.10]<.0432>
 YD/DP .444 (0) (-.218) (-.556) (-.714) [-.980;.0811] [-.609;1.63]<.000675>

YD/DP ;THE/DB -.222 (0) (-.0402) (-.294) (-.487) (-.556) (1.07) [-.625;3.23]<.00792>
 ZD/DB ;PHI/DA -.00706 (0) (-.0873) (-.109) (1.07) [-.492;.494] [-.705;3.79]<-.000251>
 ZD/DB ;PSI/DP .0398 (-.0858) (-.199) (-.556) (1.07) (5.40) [-.00949;1.26]<-.00347>

PHI/DA ;THE/DB ;PSI/DP .0342 (-.0429) (-.0741) (-.301) (-.556) (1.07) [-.194E-4>
 PHI/DC ;THE/DB ;PSI/DP .000968 (-.0354) (-.254) (-.556) (-.886) (1.07) [-.457E-5>
 THE/DC ;PHI/DA ;PSI/DP -.000455 (-.0720) (-.102) (-.556) (-.714) (6.77) [-.900E-5>

TABLE VI-5 CONTINUED
CH-53D TRANSFER FUNCTION FACTORS

CASE 182 HOVER AFCS ON

CONTROL NUMERATORS CONCLUDED:

PSI/DC ; PHI/DA ; THE/DB - .00798 (.0349) (.0988) (.270) (.556) (1.07) <- .440E-5>
 XD/DB ; PHI/DA ; PSI/DP - .292 (.0768) (.300) (.556) (1.07) [.0999; 1.94] <- .0150>
 YD/DA ; THE/DB ; PSI/DP .0687 (.0403) (.290) (.556) (1.07) [.103; 3.99] <.00760>
 ZD/DC ; PHI/DA ; THE/DB .599 (0) (.0439) (.0713) (.0984) (1.07) (2.06) <.000406>
 ZD/DC ; THE/DB ; PSI/DP - .407 (.0408) (.360) (.556) (.944) (1.07) (4.24) <- .0142>
 ZD/DC ; PHI/DA ; PSI/DP 1.22 (.0843) (.115) (.556) (.714) [.606; 1.63] <.0125>
 XD/DC ; PHI/DA ; THE/DB - .00511 (0) (.0863) (.0983) (1.07) [.835; 2.15] <- .000213>
 XD/DC ; PHI/DA ; PSI/DP .00128 (.0988) (.556) (.714) (5.57) [-.942; 2.38] <.00159>
 XD/DC ; THE/DB ; PSI/DP .000927 (.361) (.556) (.855) (1.07) [.880; 5.98] <.00605>
 YD/DP ; PHI/DA ; THE/DB - .0803 (0) (.211) (.556) (1.07) [.981; .0495] <- .246E-4>
 ZD/DB ; PHI/DA ; PSI/DP .00281 (-.158) (.556) (1.07) (5.71) [.433; .545] <- .000446>
 ZD/DC ; PHI/DA ; THE/DB ; PSI/DP - .220 (.0412) (.0864) (.556) (1.07) <- .000463>
 XD/DC ; PHI/DA ; THE/DB ; PSI/DP .000469 (.0898) (.556) (1.07) (8.16) <.000204>

GUST NUMERATORS:

PHI/UG - .00251 (0) (0) (.0833) (.133) (.714) (1.78) (-2.18) [.000; .285] <.626E-5>
 THE/UG - .00570 (0) (0) (.0721) (.311) (.347) (.714) (1.01) (2.17) (3.86) <- .000269>
 PSI/UG .00113 (0) (.315) (.335) (.602) (.714) (1.14) (5.03) [.392; 1.29] <.000492>
 PHI/VG .0307 (0) (0) (.0728) (.114) (.302) (.714) (1.90) [.620; 1.65] <.000284>
 THE/VG - .00202 (0) (0) (.466) (.714) (1.89) [.981; .0793] [.365; 2.32] <- .430E-4>
 PSI/VG - .00262 (0) (.121) (.275) (.553) (.714) (1.20) (7.57) [.621; 1.64] <- .000839>
 PHI/WG - .00116 (0) (0) (.0730) (.113) (.289) (.714) (5.00) [.971; 1.44] <- .205E-4>
 THE/WG .00243 (0) (0) (.0744) (.0791) (.364) (.714) (1.08) (2.22) (3.54) <.316E-4>
 PSI/WG - .000395 (0) (.0532) (.443) (.714) (3.84) [.996; .895] [.180; .926] <- .175E-4>
 PHI/PG 1.88 (0) (.0734) (.113) (.124) (.301) (.714) (2.12) [.636; 1.65] <.00242>
 THE/PG - .189 (0) (-.0689) (.0754) (.153) (.430) (.714) (2.08) [.656; 2.10] <.000424>
 PSI/PG .144 (.106) (-.276) (.548) (.714) (1.45) [-.276; 1.09] [.651; 1.70] <.00808>
 PHI/QG .905 (0) (.0410) (.0722) (.113) (.301) (.714) (1.91) [.390; 1.40] <.000245>
 THE/QG .494 (0) (.714) (.877) (2.14) (4.32) [.998; .0754] [.972; .356] <.00207>
 PSI/QG - .0967 (.0262) (.220) (.245) (.565) (.714) (1.21) (7.09) [.472; 1.42] <- .000945>
 PHI/RG - .414 (0) (.0743) (.114) (-.148) (.303) (.714) (1.08) [.604; 1.61] <.000313>
 THE/RG - .0892 (0) (.0916) (-.190) (.636) (.714) (1.11) [.395; .334] <.874E-4>
 PSI/RG .335 (.112) (.556) (.714) (1.06) (4.19) [.993; .301] [.630; 1.63] <.0158>
 XD/UG .0897 (0) (.0736) (.308) (.350) (.714) (1.01) (2.17) (3.86) [.306; 1.82] <.0142>
 ZD/UG .00395 (0) (0) (.0804) (.714) (2.52) (3.63) [.886; .400] [.569; 2.15] <.00153>
 YD/VG .155 (0) (.0794) (.112) (.293) (.714) (1.90) [.617; 1.64] [.567; 3.11] <.0142>
 XD/WG - .00413 (0) (0) (.0733) (.360) (.714) (1.10) (-1.40) (2.13) (3.67) (-5.42) <- .00510>
 ZD/WG .290 (0) (.0730) (.114) (.375) (.714) (1.05) (2.32) (3.43) [.634; 1.62] <.0142>
 PHI/UG ; THE/DB - .000225 (0) (0) (.305) (1.07) [.979; .0841] <- .517E-6>
 PHI/UG ; PSI/DP .000663 (0) (-.147) (.307) (.404) (.556) (.714) (-2.67) <.128E-4>
 THE/UG ; PHI/DA - .00297 (0) (0) (.0735) (.0980) (.304) (.714) (2.11) <- .979E-5>
 THE/UG ; PSI/DP .00203 (0) (.556) (.714) (.972) (4.21) [.999; .317] <.000332>
 PSI/UG ; PHI/DA .000671 (0) (.0969) (.304) (.621) (.714) [.428; 1.38] <.166E-4>
 PSI/UG ; THE/DB - .000174 (0) (.306) (.412) (.556) (.910) (1.07) (4.06) <- .480E-4>
 PHI/VG ; THE/DB - .00566 (0) (0) (.0439) (.0707) (.304) (1.07) (1.90) <- .108E-4>
 PHI/VG ; PSI/DP - .0103 (0) (.113) (.302) (.556) (.714) [.620; 1.65] <- .000380>
 THE/VG ; PHI/DA - .000865 (0) (0) (.569) (.714) (1.92) [.983; .0810] <- .443E-5>
 THE/VG ; PSI/DP .000665 (0) (.0678) (.465) (.556) (.714) [.340; 2.28] <.433E-4>
 PSI/VG ; PHI/DA - .00237 (0) (-.120) (.275) (.556) (.714) [.614; 1.65] <- .845E-4>
 PSI/VG ; THE/DB .000480 (0) (.0372) (.286) (.556) (1.07) (1.17) (7.67) <.272E-4>

TABLE VI-5 CONTINUED
CH-53D TRANSFER FUNCTION FACTORS

CASE 182 HOVER AFCS ON

GUST NUMERATORS CONTINUED:	
PHI/WG ; THE/DB	.000397 (0) (0) (.0451) (.0707) (.269) (1.07) (2.24) <-.813E-6>
PHI/WG ; PSI/DP	.000486 (0) (.120) (.245) (.556) (.714) (1.25) (3.44) <-.242E-4>
THE/WG ; PHI/DA	.00125 (0) (0) (.119) (.714) (2.11) [.992;.0778] <-.135E-5>
THE/WG ; PSI/DP	-.000863 (0) (.0804) (.342) (.556) (.714) (1.05) (3.92) <-.386E-4>
PSI/WG ; PHI/DA	-.000166 (0) (.115) (-.288) (-.638) (.714) [.356;1.14] <-.328E-5>
PSI/WG ; THE/DB	.583E-4 (0) (.110) (.556) (1.07) (2.31) [.638;.685] <-.411E-5>
PHI/PG ; THE/DB	-.352 (0) (.0432) (-.0717) (.124) (.301) (1.07) (2.11) <-.916E-4>
PHI/PG ; PSI/DP	-.693 (.299) (.556) (.714) [.996;.107] [.636;1.66] <-.00261>
THE/PG ; PHI/DA	-.0870 (0) (.0342) (.0664) (.109) (.283) (.714) (2.11) <-.916E-5>
THE/PG ; PSI/DP	.0693 (-.0619) (.138) (.425) (.556) (.714) [.668;2.08] <-.000429>
PSI/PG ; PHI/DA	.0127 (.112) (-.288) (-.616) (-.647) (.714) [.436;1.20] <-.000169>
PSI/PG ; THE/DB	-.0249 (.0316) (.286) (.556) (1.07) (1.56) [-.230;1.12] <-.000260>
PHI/QG ; THE/DB	-.123 (0) (.0245) (.0571) (.0689) (.302) (1.07) (1.86) <-.714E-5>
PHI/QG ; PSI/DP	-.300 (.0377) (-.125) (.299) (.556) (.714) [.385;1.42] <-.000337>
THE/QG ; PHI/DA	.262 (0) (.107) (.300) (.714) (2.11) [.996;.0757] <-.724E-4>
THE/QG ; PSI/DP	-.176 (-.0769) (.556) (.714) (.844) (4.65) [.964;.346] <-.00252>
PSI/QG ; PHI/DA	-.0800 (.0341) (.111) (.300) (.599) (.714) [.485;1.44] <-.807E-4>
PSI/QG ; THE/DB	.0148 (-.278) (.556) (1.07) (1.15) (6.65) [.743;.118] <-.000261>
PHI/RG ; THE/DB	.0744 (0) (.0432) (.0727) (-.148) (.306) (1.04) (1.07) <-.118E-4>
PHI/RG ; PSI/DP	.0808 (.307) (.556) (.714) [.999;.104] [.576;1.62] <-.000278>
THE/RG ; PHI/DA	-.00751 (0) (0) (.00798) (.0759) (-.358) (.714) <-.116E-5>
THE/RG ; PSI/DP	.00444 (.160) (.556) (.602) (.714) (8.86) [.259;.206] <-.640E-4>
PSI/RG ; PHI/DA	-.187 (-.0760) (.117) (.293) (.557) (.714) [.604;1.63] <-.000514>
PSI/RG ; THE/DB	-.0600 (.0416) (.556) (.992) (1.07) (4.44) [.993;.302] <-.000592>
XD/UG ; PHI/DA	.0468 (0) (.0747) (.0979) (.302) (.714) (2.10) [.306;1.82] <-.000514>
XD/UG ; THE/DB	-.00736 (0) (.0762) (1.01) (1.07) (2.16) (3.86) [.996;.328] <-.000539>
XD/UG ; PSI/DP	-.0317 (.556) (.714) (.973) (4.19) [.998;.318] [.306;1.82] <-.0173>
ZD/UG ; PHI/DA	.00190 (0) (0) (.0824) (.111) (.714) (3.12) [.491;1.58] <-.961E-4>
ZD/UG ; THE/DB	-.000733 (0) (0) (.0867) (.143) (1.07) (1.43) (2.61) (3.82) <-.000139>
ZD/UG ; PSI/DP	-.00132 (0) (-.186) (.474) (.556) (.714) (4.30) [.415;2.13] <-.000901>
YD/VG ; PHI/DA	-.0506 (0) (.265) (.714) (1.91) [.998;.103] [.609;1.63] <-.000514>
YD/VG ; THE/DB	-.0281 (0) (.0430) (.0775) (.294) (1.07) (1.90) [.575;3.11] <-.000539>
YD/VG ; PSI/DP	-.0514 (-.112) (.293) (.556) (.714) [.617;1.64] [.557;3.10] <-.0173>
XD/WG ; PHI/DA	-.00203 (0) (0) (.0776) (.120) (.714) (-1.66) (2.10) (-4.83) <-.000228>
XD/WG ; THE/DB	-.00296 (0) (0) (.0727) (.376) (.924) (1.07) (2.23) (4.08) <-.000726>
XD/WG ; PSI/DP	.00145 (0) (.337) (.556) (.714) (1.06) (-1.39) (3.89) (-5.59) <-.00620>
ZD/WG ; PHI/DA	.151 (0) (.0740) (.102) (.113) (.714) (2.09) [.605;1.63] <-.000514>
ZD/WG ; THE/DB	-.0520 (0) (.0438) (.0709) (.384) (.960) (1.07) (2.22) (3.82) <-.000539>
ZD/WG ; PSI/DP	-.103 (.112) (.356) (.556) (.714) (1.02) (3.95) [.636;1.62] <-.0173>
XD/UG ; ZD/DC	-.575 (0) (.0734) (.367) (.714) (.980) (2.15) (3.86) [.306;1.82] <-.298>
YD/VG ; ZD/DC	-.947 (0) (.0761) (.113) (.714) (1.96) [-.620;1.64] [-.559;3.12] <-.298>
PHI/UG ; THE/DB ; PSI/DP	.339E-4 (0) (-.223) (.305) (.556) (1.07) <-.137E-5>
THE/UG ; PHI/DA ; PSI/DP	.00110 (0) (.0738) (.303) (.556) (.714) <-.975E-5>
PSI/UG ; PHI/DA ; THE/DB	-.908E-4 (0) (.100) (.304) (.556) (1.07) <-.164E-5>
PHI/VG ; THE/DB ; PSI/DP	.00190 (0) (.0407) (.304) (.556) (1.07) <-.140E-4>
THE/VG ; PHI/DA ; PSI/DP	.000280 (0) (.0711) (.556) (.569) (.714) <-.450E-5>
PSI/VG ; PHI/DA ; THE/DB	.000436 (0) (.0369) (.286) (.556) (1.07) <-.272E-5>
PHI/WG ; THE/DB ; PSI/DP	-.000152 (0) (.0359) (.245) (.556) (1.07) <-.794E-6>
THE/WG ; PHI/DA ; PSI/DP	-.000460 (0) (.0720) (.103) (.556) (.714) <-.135E-5>
PSI/WG ; PHI/DA ; THE/DB	.174E-4 (0) (-.0290) (-.0559) (.556) (1.07) <-.167E-7>

TABLE VI-5 CONTINUED
CH-53D TRANSFER FUNCTION FACTORS

CASE 182 HOVER AFCS ON

GUST NUMERATORS CONCLUDED:

PHI/PG ; THE/DB ; PSI/DP	.130 (.0433) (.0981) (.300) (.556) (1.07) <.978E-4>
THE/PG ; PHI/DA ; PSI/DP	.0320 (.0338) (.0763) (.284) (.556) (.714) <.928E-5>
PSI/PG ; PHI/DA ; THE/DB	-.00140 (.0448) (.290) (-.501) (.556) (1.07) <.541E-5>
PHI/QG ; THE/DB ; PSI/DP	.0406 (.301) (.556) (1.07) [.833; .0516] <.192E-4>
THE/QG ; PHI/DA ; PSI/DP	-.0969 (.0724) (.0864) (.300) (.556) (.714) <-.721E-4>
PSI/QG ; PHI/DA ; THE/DB	.0118 (.300) (.556) (1.07) [.863; .0710] <.105E-4>
PHI/RG ; THE/DB ; PSI/DP	-.0141 (.0430) (.0932) (.311) (.556) (1.07) <-.105E-4>
THE/RG ; PHI/DA ; PSI/DP	.00299 (.0379) (.0766) (-.129) (.556) (.714) <-.446E-6>
PSI/RG ; PHI/DA ; THE/DB	-.0337 (.0430) (.0761) (-.297) (.556) (1.07) <-.194E-4>
XD/UG ; PHI/DA ; THE/DB	-.00384 (0) (.0772) (.0982) (.299) (1.07) (2.09) <-.194E-4>
XD/UG ; PHI/DA ; PSI/DP	-.0171 (.0756) (.301) (.556) (.714) [.306; 1.82] <-.000513>
XD/UG ; THE/DB ; PSI/DP	.00258 (.556) (.970) (1.07) (4.21) [.989; .320] <.000639>
ZD/UG ; PHI/DA ; THE/DB	-.000382 (0) (0) (1.07) (2.78) [.986; .0862] <-.841E-5>
ZD/UG ; PHI/DA ; PSI/DP	-.000664 (0) (-.165) (.556) (.714) [.446; 1.68] <.000122>
ZD/UG ; THE/DB ; PSI/DP	.000248 (0) (-.129) (.556) (1.07) (1.26) (4.19) <-.000100>
YD/VG ; PHI/DA ; THE/DB	-.00913 (0) (.0418) (.0944) (.264) (1.07) (1.91) <-.194E-4>
YD/VG ; PHI/DA ; PSI/DP	-.0164 (.111) (.265) (.556) (.714) [.609; 1.63] <-.000513>
YD/VG ; THE/DB ; PSI/DP	.00932 (.0409) (.294) (.556) (1.07) [.566; 3.10] <.000639>
XD/WG ; PHI/DA ; THE/DB	-.00156 (0) (0) (.0838) (.104) (1.07) (2.11) <-.307E-4>
XD/WG ; PHI/DA ; PSI/DP	.000734 (0) (.0994) (.556) (.714) (-1.64) (-4.96) <.000236>
XD/WG ; THE/DB ; PSI/DP	.00106 (0) (.354) (.556) (.901) (1.07) (4.49) <.000896>
ZD/WG ; PHI/DA ; THE/DB	-.0271 (0) (.0433) (.0722) (.102) (1.07) (2.10) <-.194E-4>
ZD/WG ; PHI/DA ; PSI/DP	-.0550 (.0763) (.116) (.556) (.714) [.607; 1.63] <-.000513>
ZD/WG ; THE/DB ; PSI/DP	.0184 (.0410) (.362) (.556) (.931) (1.07) (4.24) <.000639>
XD/UG ; ZD/DC ; PHI/DA	-.300 (0) (.0740) (.0984) (.714) (2.06) [.306; 1.82] <-.0106>
XD/UG ; ZD/DC ; THE/DB	.0472 (0) (.0760) (.371) (.970) (1.07) (2.14) (3.86) <.0114>
XD/UG ; ZD/DC ; PSI/DP	.203 (.355) (.556) (.714) (.962) (4.19) [.306; 1.82] <.384>
YD/VG ; ZD/DC ; PHI/DA	-.306 (0) (.0839) (.111) (.714) (1.97) [.609; 1.63] <-.0106>
YD/VG ; ZD/DC ; THE/DB	.172 (0) (.0438) (.0738) (1.07) (1.96) [.567; 3.13] <.0114>
YD/VG ; ZD/DC ; PSI/DP	.332 (-.112) (.556) (.714) [.620; 1.64] [.553; 3.11] <.384>
XD/UG ; PHI/DA ; THE/DB ; PSI/DP	.00139 (.0793) (.297) (.556) (1.07) <.194E-4>
ZD/UG ; PHI/DA ; THE/DB ; PSI/DP	.000136 (0) (-.162) (.556) (1.07) <-.131E-4>
YD/VG ; PHI/DA ; THE/DB ; PSI/DP	.00297 (.0415) (.265) (.556) (1.07) <.194E-4>
XD/WG ; PHI/DA ; THE/DB ; PSI/DP	.000575 (0) (.0901) (.556) (1.07) <.307E-4>
ZD/WG ; PHI/DA ; THE/DB ; PSI/DP	.00992 (.0426) (.0774) (.556) (1.07) <.194E-4>
XD/UG ; ZD/DC ; PHI/DA ; THE/DB	.0246 (0) (.0766) (.0983) (1.07) (2.05) <.000406>
YD/VG ; ZD/DC ; PHI/DA ; THE/DB	.0553 (0) (.0432) (.0811) (1.07) (1.96) <.000406>
YD/VG ; ZD/DC ; PHI/DA ; PSI/DP	.106 (.112) (.556) (.714) [.609; 1.63] <.0125>
XD/WG ; ZD/DC ; PHI/DA ; THE/DB	.0115 (0) (.0875) (.101) (1.07) (1.96) <.000213>
XD/UG ; ZD/DC ; PHI/DA ; THE/DB ; PSI/DP	-.00893 (.0875) (.556) (1.07) <-.000463>
YD/VG ; ZD/DC ; PHI/DA ; THE/DB ; PSI/DP	-.0191 (.0409) (.556) (1.07) <-.000463>
XD/WG ; ZD/DC ; PHI/DA ; THE/DB ; PSI/DP	-.00383 (.0898) (.556) (1.07) <-.000204>

TABLE VI-5 CONTINUED
CH-53D TRANSFER FUNCTION FACTORS

CASE 183 20KT AFCS OFF

DENOMINATOR: (0) (.314) (1.75) [-.458; .249] [.799; .616] [.0560; .965] <.0120>

CONTROL NUMERATORS:

PHI/DA	.513	(0)	[-.114; .231]	[.809; .532]	[.447; .634]	<.00313>	
THE/DB	-.186	(0)	(.0204) (.254) (.354)	(1.94)	[.0568; .926]	<-.000566>	
PSI/DP	-.332	(1.78)	[-.277; .315]	[.887; .523]	[-.0135; .688]	<-.00757>	
PHI/DB	-.0893	(0)	(.332) (-.608) (.710)	(-2.04)	[.274; .886]	<-.0205>	
PHI/DP	.190	(0)	(1.27) (-1.37)	[-.269; .317]	[.897; .493]	<-.00810>	
PHI/DC	-.0197	(0)	(-1.65) (2.66)	[-.391; .544]	[.947; .600]	<.00923>	
THE/DA	.0885	(0)	(.0249) (-.312) (.438)	[.605; .679]	<-.000139>		
THE/DP	-.0137	(0)	(.00601) (-.0367) (.411)	(1.43)	[-.514; 2.29]	<.935E-5>	
THE/DC	.0331	(0)	(.0403) (.141) (.609)	(1.86)	[.0410; 1.13]	<.000272>	
PSI/DA	.0324	(1.33)	[-.207; .187]	[.857; .610]	[-.458; 2.04]	<.00233>	
PSI/DB	.0246	(.332)	(-1.66) (2.06)	[-.263; .749]	[.536; 1.11]	<-.0194>	
PSI/DC	.0909	(1.73)	[-.417; .466]	[.930; .659]	[.0346; .769]	<.00880>	
XD/DB	1.51	(0)	(.254) (.350) (2.00)	[.0552; .930]	[.0341; 1.96]	<.891>	
YD/DA	.952		[-.0240; .217]	[.788; .547]	[.344; .588]	[.0611; 4.13]	<.0787>
ZD/DC	-6.27	(0)	(1.76) [-.722; .0725]	[.658; .601]	[.0373; .953]	<-.0191>	
XD/DC	-.0908	(0)	(.165) (.603) (1.93)	[.0600; 1.08]	[-.115; 3.53]	<-.252>	
YD/DP	1.15	(-1.28)	(1.29)	[-.261; .316]	[.889; .487]	[.254; 2.39]	<-.256>
ZD/DB	.654	(0)	(.296) (-.473) (1.96)	[.0434; .907]	[.144; 1.94]	<-.555>	
PHI/DA ; THE/DB	-.0961	(0)	(.0231) (.375)	[.447; .679]	<-.000384>		
PHI/DA ; PSI/DP	-.176	(.0856)	[-.260; .316]	[.906; .516]	<-.000400>		
THE/DB ; PSI/DP	.0620	(.0177)	(.374) (1.95)	[-.0839; .681]	<.000371>		
PHI/DB ; PSI/DP	.0250	(.102)	(.363) (-2.09)	[-.115; .268]	<-.000139>		
PHI/DP ; THE/DB	-.0365	(0)	(.0178) (.374)	(1.18)	(-1.39)	<.000397>	
PHI/DC ; THE/DB	.00663	(0)	(-.00357) (.452)	(1.54)	(-1.76)	<.290E-4>	
THE/DA ; PSI/DP	-.0305	(.0283)	(.318) (-.527)	(.592)	<.858E-4>		
THE/DP ; PHI/DA	-.00569	(0)	(.0290) (.367)	[.115; 1.23]	<-.912E-4>		
THE/DC ; PHI/DA	.0169	(0)	(.0285) (.656)	[.411; .751]	<.000177>		
PSI/DA ; THE/DB	-.00586	(.0233)	(.379) (1.76)	[-.418; 1.91]	<-.000334>		
PSI/DB ; PHI/DA	.0155	(.0864)	(.338) (-1.71)	[.247; 1.18]	<-.00107>		
PSI/DC ; THE/DB	-.0177	(-.00300)	(.460) (1.94)	[-.0605; .704]	<.236E-4>		
PSI/DC ; PHI/DA	.0473	(.0921)	[-.330; .499]	[.941; .680]	<.000502>		
XD/DB ; PHI/DA	.784	(0)	(.367)	[.447; .681]	[.0304; 1.99]	<.531>	
XD/DB ; PSI/DP	-.501	(.368)	(2.00)	[-.0829; .682]	[.0335; 1.97]	<-.667>	
YD/DA ; THE/DB	-.178	(.0234)	(.372)	[.377; .650]	[.0571; 4.15]	<-.0113>	
YD/DA ; PSI/DP	-.353		[-.245; .315]	[.904; .511]	[.0464; 3.98]	<-.145>	
ZD/DC ; PHI/DA	-3.22	(0)	(-1.29)	[.278; .583]	[.642; .597]	<.0505>	
ZD/DC ; THE/DB	1.14	(0)	(.0357) (.199)	(1.94)	[.0458; .923]	<.0134>	
ZD/DC ; PSI/DP	2.08	(.220)	(1.79)	[.190; .321]	[.0117; .685]	<.0397>	
XD/DC ; PHI/DA	-.0447	(0)	(.657)	[.408; .747]	[-.0357; 3.49]	<-.200>	
XD/DC ; THE/DB	-.0332	(0)	(.252) (.747)	(2.06)	[.0292; .803]	<-.00829>	
XD/DC ; PSI/DP	.0308	(.709)	(2.48)	[-.103; .666]	[.0356; 2.93]	<.207>	
YD/DP ; PHI/DA	.409	(1.10)	(-1.11)	[-.253; .327]	[.934; .504]	<-.0135>	
YD/DP ; THE/DB	-.216	(.0177)	(.372)	(1.19)	(-1.29)	[.269; 2.39]	<.0125>
ZD/DB ; PHI/DA	.340	(0)	(-1.469)	[.509; .686]	[.145; 1.89]	<-.267>	
ZD/DB ; PSI/DP	-.216	(-.402)	(1.97)	[-.0897; .668]	[.106; 1.95]	<.288>	
PHI/DA ; THE/DB ; PSI/DP	.0332	(.0171)	(.0849)	(.374)	<.181E-4>		
PHI/DC ; THE/DB ; PSI/DP	.00127	(.0128)	(.350)	(-1.442)	<-.251E-5>		
THE/DC ; PHI/DA ; PSI/DP	-.00527	(.0275)	(.0772)	(.722)	<-.808E-5>		

TABLE VI-5 CONTINUED
CH-53D TRANSFER FUNCTION FACTORS

CASE 183 20KT AFCS OFF

CONTROL NUMERATORS CONCLUDED:

PSI/DC ; PHI/DA ; THE/DB -.00936 (.00223) (.111) (.479) <-.111E-5>

XD/DB ; PHI/DA ; PSI/DP -.269 (.0848) (.367) [.0319; 2.00] <-.0335>
 YD/DA ; THE/DB ; PSI/DP .0663 (.0176) (.372) [.0473; 3.99] <.00690>
 ZD/DC ; PHI/DA ; THE/DB .591 (0) (.0347) [.420; .661] <.00896>

ZD/DC ; THE/DB ; PSI/DP -.383 (.0251) (1.95) [-.0830; .682] <-.00872>
 ZD/DC ; PHI/DA ; PSI/DP 1.11 (.167) (.201) [.220; .280] <.00292>
 XD/DC ; PHI/DA ; THE/DB -.0174 (0) (.627) [.405; .712] <-.00553>

XD/DC ; PHI/DA ; PSI/DP .0174 (.0770) (.723) [-.0704; 3.12] <.00941>
 XD/DC ; THE/DB ; PSI/DP .00894 (.760) (1.71) [-.0786; .690] <.00554>
 YD/DP ; PHI/DA ; THE/DB -.0767 (.0172) (.372) (1.11) (-1.12) <.000610>

ZD/DB ; PHI/DA ; PSI/DP -.116 (.0846) (-.395) [.112; 1.92] <.0143>

ZD/DC ; PHI/DA ; THE/DB ; PSI/DP -.205 (.0232) (.0881) <-.000420>
 XD/DC ; PHI/DA ; THE/DB ; PSI/DP .00475 (.0762) (.693) <.000251>

GUST NUMERATORS:

PHI/UG -.00837 (0) (0) (0) (1.08) (-1.17) [-.794; .427] <.00192>
 THE/UG -.000945 (0) (0) (.346) (1.06) (3.81) [-.397; .532] <-.000374>
 PSI/UG .0109 (0) (0) (1.80) [-.787; .463] [-.0350; .659] <.00182>

PHI/VG .0345 (0) (0) (.402) [-.346; .308] [.842; .535] <.000375>
 THE/VG .00808 (0) (0) [.183; .0314] [.959; .415] <.137E-5>
 PSI/VG -.0103 (0) (0) (.171) (-.242) (2.01) [.677; .610] <.000319>

PHI/WG -.00214 (0) (0) (-.506) (.659) (1.72) [-.0841; .686] <.000577>
 THE/WG .00175 (0) (0) (.0351) (.191) (1.75) [-.0131; 1.04] <.220E-4>
 PSI/WG .00167 (0) (.978) (1.76) [-.545; .565] [.221; .785] <.000566>

PHI/PG 1.51 (0) (-.147) (.160) [.303; .645] [.808; .711] <-.00745>
 THE/PG -.194 (0) (.0136) (.971) [.944; .454] [-.365; 1.07] <-.000601>
 PSI/PG .181 (.146) (-.253) (1.51) [.729; .627] [-.396; 1.53] <-.00930>

PHI/QG 1.05 (0) (.369) (.580) [-.685; .548] [.433; .795] <.0425>
 THE/QG .357 (0) (.0287) (.195) (.366) (2.33) [.133; .864] <.00127>
 PSI/QG -.0876 (.360) (-1.36) (2.76) [-.204; .525] [.754; 1.10] <.0396>

PHI/RG -.374 (0) (-1.01) (1.10) [-.294; .334] [.895; .521] <.0127>
 THE/RG .0182 (0) (.453) (1.26) [-.311; .0271] [-.665; 2.46] <.463E-4>
 PSI/RG .470 (1.79) [-.330; .334] [.880; .541] [.0204; .662] <.0120>

XD/UG .0325 (0) (.346) (.956) (2.58) [-.387; .482] [.0331; 1.37] <.0120>
 ZD/UG .172 (0) (0) (.590) (1.83) [.150; .252] [.138; 1.04] <.0126>
 YD/VG .179 (0) (.402) [-.343; .307] [.836; .532] [.232; 2.51] <.0120>

XD/WG -.00631 (0) (0) (-.208) (1.75) [.0144; 1.02] [-.146; 3.02] <-.0219>
 ZD/WG .363 (0) (1.75) [-.416; .275] [.919; .514] [.0616; .971] <.0120>

PHI/UG ; THE/DB .00147 (0) (0) (.350) (1.09) (-1.13) <-.000637>
 PHI/UG ; PSI/DP .000704 (0) (-.110) (.508) [-.600; .149] <-.867E-6>
 THE/UG ; PHI/DA -.000543 (0) (0) (1.01) [.436; .421] <-.972E-4>

THE/UG ; PSI/DP .000463 (0) (.575) (2.15) [-.0699; .641] <.000235>
 PSI/UG ; PHI/DA .00588 (0) (-.00255) (.101) [.824; .420] <-.267E-6>
 PSI/UG ; THE/DB -.00201 (0) (.350) (1.95) [-.0764; .662] <-.000602>

PHI/VG ; THE/DB -.00635 (0) (0) (.0173) [.988; .374] <-.153E-4>
 PHI/VG ; PSI/DP -.00949 (0) [-.270; .317] [.890; .498] <-.000236>
 THE/VG ; PHI/DA .000611 (0) (0) (.0276) [.913; .527] <.469E-5>

THE/VG ; PSI/DP -.000381 (0) (.367) (6.64) [.201; .0305] <-.864E-6>
 PSI/VG ; PHI/DA -.00641 (0) [-.283; .203] [.826; .524] <-.727E-4>
 PSI/VG ; THE/DB .00190 (0) (.377) (2.04) [.133; .0390] <.221E-5>

TABLE VI-5 CONTINUED
CH-53D TRANSFER FUNCTION FACTORS

CASE 183 20KT AFCS OFF

GUST NUMERATORS CONTINUED:

PHI/WG ; THE/DB	.000553	(0)	(0)	(-.0747)	(-.296)	(.852)	<.104E-4>
PHI/WG ; PSI/DP	.000391	(0)	(.233)	(2.20)	[-.207;.298]	<.178E-4>	
THE/WG ; PHI/DA	.000881	(0)	(0)	(.0282)	[.417;.706]	<.124E-4>	
THE/WG ; PSI/DP	-.000556	(0)	(.0272)	(1.81)	[-.140;.723]	<-.143E-4>	
PSI/WG ; PHI/DA	.000928	(0)	(.0990)	(1.03)	[-.281;.611]	<.354E-4>	
PSI/WG ; THE/DB	-.000354	(0)	(-.0418)	(1.97)	[.0637;.551]	<.887E-5>	
PHI/PG ; THE/DB	-.298	(0)	(.0117)	(.375)	[.456;.719]	<-.000675>	
PHI/PG ; PSI/DP	-.535	(.0974)	[-.243;.313]	[.936;.554]	<-.00157>		
THE/PG ; PHI/DA	-.0893	(0)	(.0163)	(.374)	[.452;.667]	<-.000243>	
THE/PG ; PSI/DP	.0669	(.0132)	(.360)	(1.09)	[-.443;1.05]	<.000386>	
PSI/PG ; PHI/DA	.0440	(.0939)	(.307)	(-.992)	[.399;.880]	<-.000974>	
PSI/PG ; THE/DB	-.0289	(.0109)	(.378)	(1.80)	[-.363;1.57]	<-.000532>	
PHI/QG ; THE/DB	-.162	(0)	(-.00802)	(.365)	[.490;.579]	<.000160>	
PHI/QG ; PSI/DP	-.330	(.0239)	[-.381;.313]	[.847;.389]	<-.000117>		
THE/QG ; PHI/DA	.190	(0)	(.0261)	(.365)	[.453;.673]	<.000821>	
THE/QG ; PSI/DP	-.119	(.0230)	(.370)	(2.35)	[-.0381;.590]	<-.000828>	
PSI/QG ; PHI/DA	-.0789	(.0914)	(.315)	(-.955)	[.408;.973]	<.00206>	
PSI/QG ; THE/DB	.00753	(-.0109)	(.368)	(-1.12)	(1.47)	(3.62) <.000179>	
PHI/RG ; THE/DB	.0711	(0)	(.0175)	(.385)	(-1.03)	(1.05) <-.000517>	
PHI/RG ; PSI/DP	.0348	(.123)	[-.247;.317]	[.819;.545]	<.000127>		
THE/RG ; PHI/DA	.00675	(0)	(.0275)	(.473)	[.202;1.34]	<.000158>	
THE/RG ; PSI/DP	.00591	(.0190)	(-.749)	[.605;.676]	<-.385E-4>		
PSI/RG ; PHI/DA	.253	(.0875)	[-.281;.323]	[.892;.540]	<.000675>		
PSI/RG ; THE/DB	-.0878	(.0175)	(.385)	(1.96)	[-.0722;.652]	<-.000491>	
XD/UG ; PHI/DA	.0175	(0)	(.811)	[.425;.403]	[.0660;1.17]	<.00313>	
XD/UG ; THE/DB	-.00461	(0)	(.251)	(.345)	(2.21)	[.0643;.799] <-.000566>	
XD/UG ; PSI/DP	-.0107	(.547)	(2.04)	[-.0747;.632]	[.0485;1.26]	<-.00757>	
ZD/UG ; PHI/DA	.0886	(0)	(0)	[.828;.253]	[.510;.762]	<.00329>	
ZD/UG ; THE/DB	-.0313	(0)	(0)	(.338)	(1.94)	[.107;.931] <-.0178>	
ZD/UG ; PSI/DP	-.0564	(0)	(1.81)	[.351;.404]	[.0240;.692]	<-.00795>	
YD/VG ; PHI/DA	.0591	(0)	(.401)	[-.325;.312]	[.847;.541]	<.000675>	
YD/VG ; THE/DB	-.0332	(0)	(.0173)	[.989;.373]	[.242;2.48]	<-.000491>	
YD/VG ; PSI/DP	-.0476	[-.264;.317]	[.883;.494]	[.223;2.55]	<-.00757>		
XD/WG ; PHI/DA	-.00304	(0)	(0)	[.416;.704]	[-.0339;3.06]	<-.0141>	
XD/WG ; THE/DB	-.00147	(0)	(0)	(.253)	(2.26)	[-.0912;.848] <-.000602>	
XD/WG ; PSI/DP	.00211	(0)	(1.82)	[-.126;.727]	[-.0874;2.88]	<.0169>	
ZD/WG ; PHI/DA	.186	(0)	(.458)	[-.0915;.295]	[.483;.649]	<.00313>	
ZD/WG ; THE/DB	-.0686	(0)	(.0207)	(.239)	(1.94)	[.0617;.927] <-.000566>	
ZD/WG ; PSI/DP	-.120	(.607)	(1.77)	[-.306;.345]	[-.0129;.700]	<-.00757>	
XD/UG ; ZD/DC	-.188	(0)	(-.0326)	(-.625)	(1.07)	(2.74) [.0548;1.30] <-.0191>	
YD/VG ; ZD/DC	-1.12	(0)	[.808;.150]	[.617;.348]	[.233;2.51]	<-.0191>	
PHI/UG ; THE/DB ; PSI/DP	-.968E-4	(0)	(.128)	(.345)	<-.427E-5>		
THE/UG ; PHI/DA ; PSI/DP	.000252	(0)	(.0860)	(.574)	<.124E-4>		
PSI/UG ; PHI/DA ; THE/DB	-.00108	(0)	(.0873)	(.350)	<-.331E-4>		
PHI/VG ; THE/DB ; PSI/DP	.00175	(0)	(.0178)	(.374)	<.116E-4>		
THE/VG ; PHI/DA ; PSI/DP	-.000281	(0)	(.0288)	(.337)	<-.272E-5>		
PSI/VG ; PHI/DA ; THE/DB	.00118	(0)	(.0236)	(.378)	<.105E-4>		
PHI/WG ; THE/DB ; PSI/DP	-.000115	(0)	(.0157)	(.338)	<-.609E-6>		
THE/WG ; PHI/DA ; PSI/DP	-.000292	(0)	(.0267)	(.0711)	<-.556E-6>		
PSI/WG ; PHI/DA ; THE/DB	-.000200	(0)	(.00355)	(.163)	<-.116E-6>		

TABLE VI-5 CONTINUED
CH-53D TRANSFER FUNCTION FACTORS

CASE 183 20KT AFCS OFF

GUST NUMERATORS CONCLUDED:

PHI/PG ; THE/DB ; PSI/DP	.105 (.0184) (.0967) (.374) <.698E-4>
THE/PG ; PHI/DA ; PSI/DP	.0312 (.00281) (.0812) (.373) <.265E-5>
PSI/PG ; PHI/DA ; THE/DB	-.00554 (.0605) (-.293) (.375) <.369E-4>
PHI/QG ; THE/DB ; PSI/DP	.0527 (.0228) (.0464) (.374) <.209E-4>
THE/QG ; PHI/DA ; PSI/DP	-.0662 (.0230) (.0812) (.365) <-.451E-4>
PSI/QG ; PHI/DA ; THE/DB	.00901 (.404) [.460; .0870] <.275E-4>
PHI/RG ; THE/DB ; PSI/DP	-.00647 (.0176) (.127) (.383) <-.553E-5>
THE/RG ; PHI/DA ; PSI/DP	.000489 (.0103) (.0745) (-1.59) <-.595E-6>
PSI/RG ; PHI/DA ; THE/DB	-.0476 (.0178) (.0885) (.385) <-.289E-4>
XD/UG ; PHI/DA ; THE/DB	-.00244 (0) (.320) [.400; .702] <-.000384>
XD/UG ; PHI/DA ; PSI/DP	-.00575 (.0862) (.547) [.0564; 1.22] <-.000400>
XD/UG ; THE/DB ; PSI/DP	.00130 (.310) (2.02) [-.0782; .676] <.000371>
ZD/UG ; PHI/DA ; THE/DB	-.0162 (0) (0) [.564; .733] <-.00871>
ZD/UG ; PHI/DA ; PSI/DP	-.0300 (0) (.0917) [.468; .393] <-.000426>
ZD/UG ; THE/DB ; PSI/DP	.0102 (0) (1.95) [-.0853; .684] <.00935>
YD/VG ; PHI/DA ; THE/DB	-.0110 (0) (.0176) [.966; .385] <-.289E-4>
YD/VG ; PHI/DA ; PSI/DP	-.0152 [-.256; .329] [.928; .493] <-.000400>
YD/VG ; THE/DB ; PSI/DP	.00885 (.0177) (.375) [.233; 2.51] <.000371>
XD/WG ; PHI/DA ; THE/DB	-.000778 (0) (0) [.419; .691] <-.000371>
XD/WG ; PHI/DA ; PSI/DP	.00108 (0) (.0705) [-.0275; 2.95] <.000664>
XD/WG ; THE/DB ; PSI/DP	.000446 (0) (2.17) [-.0588; .669] <.000433>
ZD/WG ; PHI/DA ; THE/DB	-.0355 (0) (.0234) [.460; .680] <-.000384>
ZD/WG ; PHI/DA ; PSI/DP	-.0640 (.0878) (.597) [-.274; .346] <-.000400>
ZD/WG ; THE/DB ; PSI/DP	.0228 (.0179) (1.95) [-.0842; .682] <.000371>
XD/UG ; ZD/DC ; PHI/DA	-.102 (0) (-.501) (.918) [.232; 1.04] <.0505>
XD/UG ; ZD/DC ; THE/DB	.0340 (0) (.282) (2.20) [.0568; .799] <.0134>
XD/UG ; ZD/DC ; PSI/DP	.0619 (1.95) [-.0460; .598] [.0986; .960] <.0397>
YD/VG ; ZD/DC ; PHI/DA	-.368 (0) [.749; .179] [.675; .332] <-.00130>
YD/VG ; ZD/DC ; THE/DB	.203 (0) (.0294) (.319) [.243; 2.49] <.0117>
YD/VG ; ZD/DC ; PSI/DP	.300 (.210) [.204; .311] [.223; 2.55] <.0397>
XD/UG ; PHI/DA ; THE/DB ; PSI/DP	.000697 (.0838) (.309) <.181E-4>
ZD/UG ; PHI/DA ; THE/DB ; PSI/DP	.00548 (0) (.0843) <.000463>
YD/VG ; PHI/DA ; THE/DB ; PSI/DP	.00287 (.0172) (.365) <.181E-4>
XD/WG ; PHI/DA ; THE/DB ; PSI/DP	.000242 (0) (.0683) <.165E-4>
ZD/WG ; PHI/DA ; THE/DB ; PSI/DP	.0122 (.0173) (.0856) <.181E-4>
XD/UG ; ZD/DC ; PHI/DA ; THE/DB	.0179 (0) [.394; .707] <.00896>
YD/VG ; ZD/DC ; PHI/DA ; THE/DB	.0674 (0) (.0292) (.335) <.000661>
YD/VG ; ZD/DC ; PHI/DA ; PSI/DP	.0956 (.323) [.101; .308] <.00292>
XD/WG ; ZD/DC ; PHI/DA ; THE/DB	.0112 (0) [.395; .702] <.00553>
XD/UG ; ZD/DC ; PHI/DA ; THE/DB ; PSI/DP	-.00510 (.0823) <-.000420>
YD/VG ; ZD/DC ; PHI/DA ; THE/DB ; PSI/DP	-.0178 (.0236) <-.000420>
XD/WG ; ZD/DC ; PHI/DA ; THE/DB ; PSI/DP	-.00325 (.0773) <-.000251>

TABLE VI-5 CONTINUED
CH-53D TRANSFER FUNCTION FACTORS

CASE 183 20KT AFCS ON

DENOMINATOR: (0) (.0387) (.354) (.714) (1.30) [.796; .432] [-.606; 1.72] [.993; 2.45] <-.0424>

CONTROL NUMERATORS:

PHI/DA	.513	(0)	(.0361)	(.352)	(.714)	(1.95)	[.549; .366]	[.561; 1.72]	<.00359>
THE/DB	-.186	(0)	(.0229)	(.376)	(1.07)	(1.21)	(2.06)	(3.23)	[.786; .427] <-.00250>
PSI/DP	-.332	(.0432)	(.315)	(.354)	(.556)	(.714)	(1.28)	(3.28)	[.599; 1.73] <-.00795>
PHI/DB	-.0893	(0)	(.322)	(.428)	(-.576)	(1.07)	(1.74)	(-2.06)	[.391; .678] <-.0125>
PHI/DP	.190	(0)	(.0431)	(.352)	(.556)	(.714)	(1.04)	(-1.66)	[.574; 1.71] <-.00577>
PHI/DC	-.0197	(0)	(.0789)	(.393)	(.714)	(-2.63)	[.890; .755]	[.587; 2.34]	<.00358>
THE/DA	.0875	(0)	(.0246)	(-.378)	(.602)	(.714)	(1.99)	[.916; .282]	<-.552E-4>
THE/DP	-.0137	(0)	(.0316)	(.319)	(.556)	(.714)	(-.970; .916)	[-.0346; 2.72]	<-.000338>
THE/DC	.0331	(0)	(.0296)	(.714)	(.781)	(.973)	[.820; .455]	[.926; 2.65]	<.000775>
PSI/DA	.0324	(.0352)	(.353)	(.556)	(.714)	(1.49)	[.496; 1.75]	[-.414; 2.02]	<.00297>
PSI/DB	.0246	(.261)	(.355)	(.566)	(1.07)	(1.37)	(-1.55)	(4.84)	[.244; 1.12] <-.0178>
PSI/DC	.0909	(.0729)	(.360)	(.473)	(.563)	(.714)	(1.23)	(3.02)	[.636; 1.79] <.00539>
XD/DB	1.51	(0)	(.369)	(1.07)	(1.17)	(1.99)	(3.44)	[.788; .432]	[.0234; 1.99] <3.52>
YD/DA	.952	(.0346)	(.350)	(.714)	(1.97)	(.438; .352)	[.564; 1.73]	[.0665; 4.09]	<.100>
ZD/DC	-6.27	(0)	(.0226)	(.714)	(1.28)	[.797; .426]	[.595; 1.72]	[.990; 2.46]	<-.421>
XD/DC	-.0908	(0)	(.714)	[.827; .436]	[.986; .853]	[-.644; 2.69]	[.878; 2.72]	<-.481>	
YD/DP	1.15	(.0432)	(.351)	(.556)	(.714)	(1.05)	(-1.31)	[.579; 1.69]	[.547; 3.14] <-.268>
ZD/DB	.654	(0)	(-.452)	(1.07)	(1.19)	(2.17)	(3.16)	[.817; .447]	[.141; 1.89] <-.184>
PHI/DA ; THE/DB	-.0961	(0)	(.0232)	(.374)	(1.07)	(1.98)	[.537; .360]	<-.000228>	
PHI/DA ; PSI/DP	-.176	(.0440)	(.0845)	(.352)	(.556)	(.714)	[.562; 1.71]	<-.000269>	
THE/DB ; PSI/DP	.0620	(.0176)	(.315)	(.372)	(.556)	(1.07)	(1.18)	(3.65)	<.000326>
PHI/DB ; PSI/DP	.0250	(.102)	(.363)	(.556)	(1.07)	(-2.09)	[-.115; .268]	<-.822E-4>	
PHI/DP ; THE/DB	-.0365	(0)	(.0177)	(.374)	(.556)	(1.01)	(1.07)	(-1.66)	<.000241>
PHI/DC ; THE/DB	.00663	(0)	(-.00340)	(.409)	(1.07)	(-2.49)	[.902; .830]	<.169E-4>	
THE/DA ; PSI/DP	-.0305	(.0283)	(.318)	(-.527)	(.556)	(.592)	(.714)	<.340E-4>	
THE/DP ; PHI/DA	-.00569	(0)	(.0290)	(.367)	(.556)	(.714)	[.115; 1.23]	<-.362E-4>	
THE/DC ; PHI/DA	.0169	(0)	(.0285)	(.714)	(.741)	(1.73)	[.557; .400]	<.704E-4>	
PSI/DA ; THE/DB	-.00586	(.0233)	(.379)	(.556)	(1.07)	(1.76)	[-.418; 1.91]	<-.000198>	
PSI/DB ; PHI/DA	.0155	(.0864)	(.338)	(.573)	(1.07)	(-1.57)	[.320; 1.21]	<-.000633>	
PSI/DC ; THE/DB	-.0177	(0)	(.330)	(.548)	(.556)	(1.07)	(1.13)	(3.58)	<-.00768>
PSI/DC ; PHI/DA	.0473	(.0573)	(.152)	(.413)	(.559)	(.714)	[.584; 1.74]	<.000206>	
XD/DB ; PHI/DA	.784	(0)	(.367)	(1.07)	(1.97)	[.542; .361]	[.0304; 2.00]	<.315>	
XD/DB ; PSI/DP	-.501	(.316)	(.367)	(.556)	(1.07)	(1.15)	(3.77)	[.0263; 1.99]	<-.592>
YD/DA ; THE/DB	-.178	(.0234)	(.372)	(1.07)	(1.98)	[.420; .347]	[.0652; 4.12]	<-.00668>	
YD/DA ; PSI/DP	-.353	(.0432)	(.351)	(.556)	(.714)	[.563; 1.72]	[.0449; 3.98]	<-.0996>	
ZD/DC ; PHI/DA	-3.22	(0)	(.0203)	(.714)	(1.92)	[.538; .362]	[.552; 1.72]	<-.0348>	
ZD/DC ; THE/DB	1.14	(0)	(.0353)	(1.07)	(1.20)	(2.03)	(3.24)	[.787; .414]	<.0584>
ZD/DC ; PSI/DP	2.08	(.0320)	(.319)	(.556)	(.714)	(1.26)	(3.31)	[.588; 1.73]	<.106>
XD/DC ; PHI/DA	-.0447	(0)	(.714)	(.751)	(1.78)	[.560; .401]	[-.633; 2.58]	<-.0456>	
XD/DC ; THE/DB	-.0332	(0)	(.605)	(1.07)	(4.14)	[.768; .506]	[.918; 1.26]	<-.0360>	
XD/DC ; PSI/DP	.0308	(.317)	(.556)	(.714)	(4.64)	[.981; .856]	[-.495; 2.30]	<.0699>	
YD/DP ; PHI/DA	.409	(.0436)	(.356)	(.556)	(.714)	(1.10)	(-1.12)	[.564; 1.71]	<-.00909>
YD/DP ; THE/DB	-.216	(.0176)	(.372)	(.556)	(1.01)	(1.07)	(-1.32)	[.562; 3.14]	<.0110>
ZD/DB ; PHI/DA	.340	(0)	(-.452)	(1.07)	(2.05)	[.587; .364]	[.131; 1.89]	<-.159>	
ZD/DB ; PSI/DP	-.216	(.321)	(-.397)	(.556)	(1.07)	(1.14)	(3.67)	[.117; 1.93]	<.255>
PHI/DA ; THE/DB ; PSI/DP	.0332	(.0171)	(.0849)	(.374)	(.556)	(1.07)	<.107E-4>		
PHI/DC ; THE/DB ; PSI/DP	.00127	(.0128)	(.350)	(-.442)	(.556)	(1.07)	<-.149E-5>		
THE/DC ; PHI/DA ; PSI/DP	-.00527	(.0275)	(.0772)	(.556)	(.714)	(.722)	<-.321E-5>		

TABLE VI-5 CONTINUED
CH-53D TRANSFER FUNCTION FACTORS

CASE 183 20KT AFCS ON

CONTROL NUMERATORS CONCLUDED:

PSI/DC ; PHI/DA ; THE/DB -.00936 (.00223) (.111) (.479) (.556) (1.07) <-.658E-6>
 XD/DB ; PHI/DA ; PSI/DP -.269 (.0848) (.367) (.556) (1.07) [.0319; 2.00] <-.0199>
 YD/DA ; THE/DB ; PSI/DP .0663 (.0176) (.372) (.556) (1.07) [.0473; 3.99] <.00409>
 ZD/DC ; PHI/DA ; THE/DB .591 (0) (.0348) (1.07) (1.95) [.519; .352] <.00531>
 ZD/DC ; THE/DB ; PSI/DP -.383 (.0246) (.318) (.556) (1.07) (1.18) (3.66) <-.00764>
 ZD/DC ; PHI/DA ; PSI/DP 1.11 (-.0343) (.0837) (.556) (.714) [.553; 1.72] <.00173>
 XD/DC ; PHI/DA ; THE/DB -.0174 (0) (.712) (1.07) (1.56) [.553; .399] <-.00328>
 XD/DC ; PHI/DA ; PSI/DP .0174 (.0775) (.556) (.714) (.732) [-.518; 2.37] <.00220>
 XD/DC ; THE/DB ; PSI/DP .00894 (.312) (.556) (.601) (1.07) (1.46) (3.28) <.00426>
 YD/DP ; PHI/DA ; THE/DB -.0767 (.0172) (.372) (.556) (1.07) (1.11) (-1.12) <.000362>
 ZD/DB ; PHI/DA ; PSI/DP -.116 (.0846) (-.395) (.556) (1.07) [.112; 1.92] <.00846>
 ZD/DC ; PHI/DA ; THE/DB ; PSI/DP -.205 (.0232) (.0881) (.556) (1.07) <-.000249>
 XD/DC ; PHI/DA ; THE/DB ; PSI/DP .00475 (.0762) (.556) (.693) (1.07) <.000149>

GUST NUMERATORS:

PHI/UG -.00837 (0) (0) (.337) (.507) (.714) (1.21) (-1.26) [.549; 1.60] <.00400>
 THE/UG -.000945 (0) (0) (.567) (.714) (7.24) [-.618; .358] [.985; 1.21] <-.000517>
 PSI/UG .0109 (0) (.288) (.356) (.555) (.714) (1.29) (3.40) [.585; 1.71] <.00569>
 PHI/VG .0345 (0) (0) (.351) (.714) (1.70) [.974; .0683] [.546; 1.69] <.000197>
 THE/VG .0120 (0) (0) (.0285) (.714) (.747) (1.78) [.973; .242] <.190E-4>
 PSI/VG -.0103 (0) (.0365) (.353) (.556) (.714) (1.37) (4.44) [.567; 1.71] <-.000937>
 PHI/WG -.00214 (0) (0) (.140) (-.325) (.477) (.714) (1.10) [.796; 2.17] <.000172>
 THE/WG .00175 (0) (0) (.0291) (.714) (1.26) [-.800; .449] [.961; 2.45] <.554E-4>
 PSI/WG .00167 (0) (.0951) (.360) (.545) (.714) (1.28) (3.31) [.699; 1.83] <.000316>
 PHI/PG 1.51 (0) (.00240) (.351) (.714) (2.03) [-.606; .394] [.609; 1.74] <.000866>
 THE/PG -.194 (0) (.0157) (.427) (.714) (2.01) [-.862; .405] [.645; 1.93] <-.00115>
 PSI/PG .181 (-.0292) (.353) (.554) (.714) (1.56) [-.0376; 1.35] [.628; 1.76] <-.00651>
 PHI/QG 1.05 (0) (.147) (.355) (.714) (1.82) [-.273; .300] [.411; 1.59] <.0162>
 THE/QG .357 (0) (.0265) (.358) (.714) (1.03) (1.98) (4.12) [.754; .420] <.00359>
 PSI/QG -.0876 (.114) (.354) (.559) (-.611) (.714) (1.41) (7.19) [-.399; 1.55] <.0210>
 PHI/RG -.374 (0) (.0479) (.361) (.474) (.714) (-1.09) (1.22) [.567; 1.70] <.00840>
 THE/RG .0182 (0) (.0289) (.714) (.960) (1.13) [-.948; .408] [-.294; 3.00] <.000613>
 PSI/RG .470 (.0478) (.297) (.353) (.556) (.714) (1.29) (3.38) [.595; 1.73] <.0122>
 XD/UG .0325 (0) (.440) (.714) (5.07) [-.731; .417] [.987; 1.21] [.357; 1.79] <.0424>
 ZD/UG .172 (0) (0) (.714) (1.32) (2.11) (2.94) [.819; .453] [.585; 1.75] <.633>
 YD/VG .179 (0) (.0589) (.0874) (.349) (.714) (1.70) [.555; 1.67] [.510; 3.15] <.0107>
 XD/WG -.00631 (0) (0) (.714) (1.25) [-.810; .441] [-.562; 2.38] [.940; 2.43] <-.0365>
 ZD/WG .363 (0) (.0379) (.714) (1.31) [-.800; .433] [.616; 1.71] [.994; 2.46] <.0424>
 PHI/UG ; THE/DB .00147 (0) (0) (.351) (.501) (1.07) (1.13) (-1.25) <-.000387>
 PSI/UG ; PSI/DP .000704 (0) (.117) (.379) (.556) (.714) [.297; 1.44] <.258E-4>
 THE/UG ; PHI/DA -.000543 (0) (0) (.570) (.714) (2.75) [.446; .252] <-.386E-4>
 THE/UG ; PSI/DP .000463 (0) (.315) (.556) (.572) (.714) (1.06) (4.06) <.000142>
 PSI/UG ; PHI/DA .00588 (0) (.0871) (.343) (.555) (.714) [.554; 1.71] <.000203>
 PSI/UG ; THE/DB -.00201 (0) (.301) (.348) (.556) (1.07) (1.19) (3.70) <-.000552>
 PHI/VG ; THE/DB -.00635 (0) (0) (.0148) (.0950) (.373) (1.07) (1.69) <-.601E-5>
 PHI/VG ; PSI/DP -.00949 (0) (.0430) (.352) (.556) (.714) [.541; 1.70] <-.000165>
 THE/VG ; PHI/DA .000611 (0) (0) (.0275) (.206) (.287) (.714) (2.62) <.186E-5>
 THE/VG ; PSI/DP -.00400 (0) (.0303) (.319) (.556) (.714) (.721) <-.110E-4>
 PSI/VG ; PHI/DA -.00641 (0) (.0355) (.353) (.557) (.714) [.553; 1.71] <-.932E-4>
 PSI/VG ; THE/DB .00190 (0) (.0242) (.379) (.556) (1.07) (1.36) (4.51) <.632E-4>

TABLE VI-5 CONTINUED
CH-53D TRANSFER FUNCTION FACTORS

CASE 183 20KT AFCS ON

GUST NUMERATORS CONTINUED:

PHI/WG ; THE/DB	.000553	(0)	(0)	(-.0741)	(-.220)	(.445)	(1.07)	(1.43)	<.614E-5>
PHI/WG ; PSI/DP	.000391	(0)	(.0457)	(.407)	(.556)	(.714)	(1.22)	(3.06)	<.108E-4>
THE/WG ; PHI/DA	.000881	(0)	(0)	(.0282)	(.714)	(1.90)	[.524; .382]	<.492E-5>	
THE/WG ; PSI/DP	-.000556	(0)	(.0271)	(.315)	(.556)	(.714)	(1.28)	(3.27)	<-.786E-5>
PSI/WG ; PHI/DA	.000928	(0)	(.0534)	(.250)	(.543)	(.714)	[.635; 1.75]	<.147E-4>	
PSI/WG ; THE/DB	-.000354	(0)	(-.0136)	(.325)	(.556)	(1.07)	(1.25)	(3.94)	<.458E-5>
PHI/PG ; THE/DB	-.298	(0)	(.0114)	(.374)	(1.07)	(2.01)	[.571; .377]	<-.000389>	
PHI/PG ; PSI/DP	-.535	(.0479)	(.0961)	(.352)	(.556)	(.714)	[.603; 1.75]	<-.00105>	
THE/PG ; PHI/DA	-.0893	(0)	(.0164)	(.374)	(.714)	(2.00)	[.525; .351]	<-.963E-4>	
THE/PG ; PSI/DP	.0669	(.0109)	(.317)	(.458)	(.556)	(.714)	[.668; 1.97]	<.000164>	
PSI/PG ; PHI/DA	.0440	(.0761)	(.346)	(-.541)	(.563)	(.714)	[.441; 1.56]	<-.000612>	
PSI/PG ; THE/DB	-.0289	(.00380)	(.379)	(.556)	(1.07)	(1.89)	[-.0128; 1.45]	<-.984E-4>	
PHI/QG ; THE/DB	-.162	(0)	(-.00866)	(.372)	(1.07)	(1.89)	[.527; .312]	<.000103>	
PHI/QG ; PSI/DP	-.330	(.0233)	(.0639)	(.353)	(.556)	(.714)	[.415; 1.59]	<-.000174>	
THE/QG ; PHI/DA	.190	(0)	(.0261)	(.365)	(.714)	(1.99)	[.537; .355]	<.000326>	
THE/QG ; PSI/DP	-.119	(.0230)	(.308)	(.334)	(.556)	(.714)	(1.01)	(4.45)	<-.000506>
PSI/QG ; PHI/DA	-.0789	(.0736)	(-.336)	(.347)	(.567)	(.714)	[.400; 1.54]	<.000648>	
PSI/QG ; THE/DB	.0761	(-.0373)	(-.269)	(.380)	(.556)	(1.07)	(1.56)	<.000268>	
PHI/RG ; THE/DB	.0711	(0)	(.0175)	(.386)	(.480)	(1.07)	(-1.09)	(1.18)	<-.000315>
PHI/RG ; PSI/DP	.0348	(.0460)	(.130)	(.343)	(.556)	(.714)	[.543; 1.73]	<.843E-4>	
THE/RG ; PHI/DA	.00675	(0)	(.0276)	(.714)	[.900; .444]	[.168; 1.55]	<.629E-4>		
THE/RG ; PSI/DP	.00892	(.0174)	(.316)	(.556)	(.714)	(.853)	(-1.06)	<-.176E-4>	
PSI/RG ; PHI/DA	.253	(.0470)	(.0895)	(.357)	(.556)	(.714)	[.561; 1.72]	<.000444>	
PSI/RG ; THE/DB	-.0878	(.0176)	(.293)	(.385)	(.556)	(1.07)	(1.20)	(3.72)	<-.000461>
XD/UG ; PHI/DA	.0175	(0)	(.440)	(.714)	(2.14)	[.554; .321]	[.356; 1.73]	<.00359>	
XD/UG ; THE/DB	-.00461	(0)	(.318)	(1.07)	(4.26)	[.736; .507]	[.990; 1.21]	<-.00250>	
XD/UG ; PSI/DP	-.0107	(.316)	(.434)	(.556)	(.714)	(1.11)	(3.81)	[.354; 1.80]	<-.00795>
ZD/UG ; PHI/DA	.0886	(0)	(0)	(.714)	(2.12)	[.602; .371]	[.545; 1.72]	<.0546>	
ZD/UG ; THE/DB	-.0313	(0)	(0)	(1.07)	(1.21)	(2.21)	(3.19)	[.819; .457]	<-.0597>
ZD/UG ; PSI/DP	-.0564	(0)	(.319)	(.556)	(.714)	(1.25)	(3.33)	[.579; 1.74]	<-.0900>
YD/VG ; PHI/DA	.0591	(0)	(.0491)	(.126)	(.342)	(.714)	(1.69)	[.555; 1.72]	<.000444>
YD/VG ; THE/DB	-.0332	(0)	(.0161)	(.107)	(.370)	(1.07)	(1.69)	[.530; 3.09]	<-.000364>
YD/VG ; PSI/DP	-.0476	(.0432)	(.351)	(.556)	(.714)	[.549; 1.66]	[.495; 3.17]	<-.00795>	
XD/WG ; PHI/DA	-.00304	(0)	(0)	(.714)	(1.91)	[.524; .382]	[-.480; 2.34]	<-.00333>	
XD/WG ; THE/DB	-.00147	(0)	(0)	(1.03)	(1.07)	(1.60)	(4.21)	[.755; .474]	<-.00244>
XD/WG ; PSI/DP	.00211	(0)	(.317)	(.556)	(.714)	(1.27)	(3.26)	[-.501; 2.27]	<.00566>
ZD/WG ; PHI/DA	.186	(0)	(.0354)	(.714)	(1.96)	[.554; .365]	[.570; 1.71]	<.00359>	
ZD/WG ; THE/DB	-.0686	(0)	(.0232)	(1.07)	(1.21)	(2.07)	(3.23)	[.795; .427]	<-.00250>
ZD/WG ; PSI/DP	-.120	(.0425)	(.318)	(.556)	(.714)	(1.28)	(3.29)	[.609; 1.71]	<-.00795>
XD/UG ; ZD/DC	-.188	(0)	(.714)	(.545)	[.751; .359]	[.973; 1.14]	[.439; 1.85]	<-.421>	
YD/VG ; ZD/DC	-1.12	(0)	(.0366)	(.0815)	(.714)	(1.68)	[.545; 1.67]	[.510; 3.15]	<-.111>
PHI/UG ; THE/DB ; PSI/DP	-.968E-4	(0)	(.128)	(.345)	(.556)	(1.07)	<-.253E-5>		
THE/UG ; PHI/DA ; PSI/DP	.000252	(0)	(.0860)	(.556)	(.574)	(.714)	<.494E-5>		
PSI/UG ; PHI/DA ; THE/DB	-.00108	(0)	(.0873)	(.350)	(.556)	(1.07)	<-.196E-4>		
PHI/VG ; THE/DB ; PSI/DP	.00175	(0)	(.0178)	(.374)	(.556)	(1.07)	<.687E-5>		
THE/VG ; PHI/DA ; PSI/DP	-.000281	(0)	(.0288)	(.337)	(.556)	(.714)	<-.108E-5>		
PSI/VG ; PHI/DA ; THE/DB	.00118	(0)	(.0236)	(.378)	(.556)	(1.07)	<.624E-5>		
PHI/WG ; THE/DB ; PSI/DP	-.000115	(0)	(.0157)	(.338)	(.556)	(1.07)	<-.361E-6>		
THE/WG ; PHI/DA ; PSI/DP	-.000292	(0)	(.0267)	(.0711)	(.556)	(.714)	<-.220E-6>		
PSI/WG ; PHI/DA ; THE/DB	-.000200	(0)	(.00355)	(.163)	(.556)	(1.07)	<-.685E-7>		

TABLE VI-5 CONTINUED
CH-53D TRANSFER FUNCTION FACTORS

CASE 183 20KT AFCS ON

GUST NUMERATORS CONCLUDED:

PHI/PG ; THE/DB ; PSI/DP	.105	(.0184)	(.0967)	(.374)	(.556)	(1.07)	<.414E-4>
THE/PG ; PHI/DA ; PSI/DP	.0312	(.00281)	(.0812)	(.373)	(.556)	(.714)	<.105E-5>
PSI/PG ; PHI/DA ; THE/DB	-.00554	(.0605)	(-.293)	(.375)	(.556)	(1.07)	<.219E-4>
PHI/QG ; THE/DB ; PSI/DP	.0527	(.0228)	(.0464)	(.374)	(.556)	(1.07)	<.124E-4>
THE/QG ; PHI/DA ; PSI/DP	-.0662	(.0230)	(.0812)	(.365)	(.556)	(.714)	<-.179E-4>
PSI/QG ; PHI/DA ; THE/DB	.00901	(.404)	(.556)	(1.07)	[.460 ; .0870]	<.163E-4>	
PHI/RG ; THE/DB ; PSI/DP	-.00647	(.0176)	(.127)	(.383)	(.556)	(1.07)	<-.328E-5>
THE/RG ; PHI/DA ; PSI/DP	.000489	(.0103)	(.0745)	(.556)	(.714)	(-1.59)	<-.236E-6>
PSI/RG ; PHI/DA ; THE/DB	-.0476	(.0178)	(.0885)	(.385)	(.556)	(1.07)	<-.171E-4>
XD/UG ; PHI/DA ; THE/DB	-.00244	(0)	(.315)	(1.07)	(1.69)	[.527 ; .406]	<-.000228>
XD/UG ; PHI/DA ; PSI/DP	-.00575	(.0853)	(.434)	(.556)	(.714)	[.350 ; 1.79]	<-.000269>
XD/UG ; THE/DB ; PSI/DP	.00130	(.556)	(1.07)	(1.13)	(3.79)	[.999 ; .315]	<.000326>
ZD/UG ; PHI/DA ; THE/DB	-.0162	(0)	(0)	(1.07)	(2.10)	[.602 ; .377]	<-.00517>
ZD/UG ; PHI/DA ; PSI/DP	-.0300	(0)	(.0847)	(.556)	(.714)	[.546 ; 1.72]	<-.00300>
ZD/UG ; THE/DB ; PSI/DP	.0102	(0)	(.316)	(.556)	(1.07)	(1.18)	(3.66) <.00826>
YD/VG ; PHI/DA ; THE/DB	-.0110	(0)	(.0177)	(.134)	(.359)	(1.07)	(1.71) <-.171E-4>
YD/VG ; PHI/DA ; PSI/DP	-.0152	(.0436)	(.349)	(.556)	(.714)	[.558 ; 1.71]	<-.000269>
YD/VG ; THE/DB ; PSI/DP	.00885	(.0176)	(.372)	(.556)	(1.07)	[.515 ; 3.09]	<.000326>
XD/WG ; PHI/DA ; THE/DB	-.000778	(0)	(0)	(1.07)	(1.82)	[.524 ; .382]	<-.000220>
XD/WG ; PHI/DA ; PSI/DP	.00108	(0)	(.0718)	(.556)	(.714)	[-.437 ; 2.29]	<.000162>
XD/WG ; THE/DB ; PSI/DP	.000446	(0)	(.313)	(.556)	(1.07)	(1.04)	(4.09) <.000354>
ZD/WG ; PHI/DA ; THE/DB	-.0355	(0)	(.0235)	(1.07)	(1.99)	[.543 ; .359]	<-.000228>
ZD/WG ; PHI/DA ; PSI/DP	-.0640	(.0435)	(.0842)	(.556)	(.714)	[.571 ; 1.70]	<-.000269>
ZD/WG ; THE/DB ; PSI/DP	.0228	(.0177)	(.316)	(.556)	(1.07)	(1.18)	(3.66) <.000326>
XD/UG ; ZD/DC ; PHI/DA	-.102	(0)	(.714)	(2.15)	[.601 ; .277]	[.459 ; 1.70]	<-.0348>
XD/UG ; ZD/DC ; THE/DB	.0340	(0)	(1.07)	(4.24)	[.739 ; .512]	[.981 ; 1.20]	<.0584>
XD/UG ; ZD/DC ; PSI/DP	.0619	(.320)	(.556)	(.714)	(1.16)	(3.65)	[.463 ; 1.78] <.106>
YD/VG ; ZD/DC ; PHI/DA	-.368	(0)	(.0318)	(.110)	(.714)	(1.67)	[.545 ; 1.72] <-.00456>
YD/VG ; ZD/DC ; THE/DB	.203	(0)	(.0291)	(.0849)	(1.07)	(1.68)	[.529 ; 3.09] <.00858>
YD/VG ; ZD/DC ; PSI/DP	-.309	(.0320)	(.556)	(.714)	[.540 ; 1.67]	[.494 ; 3.17]	<.106>
XD/UG ; PHI/DA ; THE/DB ; PSI/DP	.000697	(.0838)	(.309)	(.556)	(1.07)	<.107E-4>	
ZD/UG ; PHI/DA ; THE/DB ; PSI/DP	.00549	(0)	(.0843)	(.556)	(1.07)	<.000274>	
YD/VG ; PHI/DA ; THE/DB ; PSI/DP	.00287	(.0172)	(.365)	(.556)	(1.07)	<.107E-4>	
XD/WG ; PHI/DA ; THE/DB ; PSI/DP	.000342	(0)	(.0683)	(.556)	(1.07)	<.980E-5>	
ZD/WG ; PHI/DA ; THE/DB ; PSI/DP	.0122	(.0173)	(.0856)	(.556)	(1.07)	<.107E-4>	
XD/UG ; ZD/DC ; PHI/DA ; THE/DB	.0479	(0)	(1.07)	(1.67)	[.532 ; .408]	<.00531>	
YD/VG ; ZD/DC ; PHI/DA ; THE/DB	.0674	(0)	(.0304)	(.105)	(1.07)	(1.70)	<.000392>
YD/VG ; ZD/DC ; PHI/DA ; PSI/DP	.0956	(.0333)	(.556)	(.714)	[.548 ; 1.72]	<.00373>	
XD/WG ; ZD/DC ; PHI/DA ; THE/DB	.0112	(0)	(1.07)	(1.69)	[.527 ; .402]	<.00328>	
XD/UG ; ZD/DC ; PHI/DA ; THE/DB ; PSI/DP	-.00510	(.0823)	(.556)	(1.07)	<-.000249>		
YD/VG ; ZD/DC ; PHI/DA ; THE/DB ; PSI/DP	-.0178	(.0236)	(.556)	(1.07)	<-.000249>		
XD/WG ; ZD/DC ; PHI/DA ; THE/DB ; PSI/DP	-.00325	(.0773)	(.556)	(1.07)	<-.000149>		

TABLE VI-5 CONTINUED
CH-53D TRANSFER FUNCTION FACTORS

CASE 185 40KT AFCS OFF

DENOMINATOR: (0) (.145) (1.64) [-.321;.595] [.934;.733] [.178;.898] <.0365>

CONTROL NUMERATORS:

PHI/DA .500 (0) [-.325;.612] [.943;.707] [.381;.781] <.0571>
THE/DB -.172 (0) [-.0602] (.137) (.586) (1.82) [.166;.876] <.00116>
PSI/DP -.341 (1.66) [-.0412;.512] [-.317;.571] [.944;.729] <-.0257>

PHI/DB -.0788 (0) (.352) (-.645) (.709) (-1.43) [.240;.727] <-.00957>
THE/DA .0774 (0) (-.0105) (-.247) (-.607) [.455;.758] <.699E-4>

PHI/DA ; THE/DB -.0865 (0) (-.0587) (.587) [.375;.782] <.00182>
PHI/DA ; PSI/DP -.177 (.0443) [-.325;.612] [.949;.709] <-.00147>
THE/DB ; PSI/DP .0587 (-.0607) (.586) (1.82) [-.0579;.465] <-.000825>

PHI/DB ; PSI/DP .0248 (.0349) (.271) (-.538) (.604) (-1.41) <.000107>
PHI/DP ; THE/DB -.0361 (0) [-.0607] (.586) (1.13) (-1.20) <-.00174>
PHI/DC ; THE/DB -.00131 (0) (-.0708) (-.711) [.155;2.18] <.000314>

THE/DA ; PSI/DP -.0272 (.00645) (.311) (-.470) (.624) <.160E-4>
THE/DP ; PHI/DA -.00345 (0) (.00753) (.558) [.202;1.64] <-.391E-4>
THE/DC ; PHI/DA .0122 (0) (-.0215) (1.08) [.367;.806] <-.000183>

PSI/DA ; THE/DB -.00489 (-.0586) (.590) (1.72) [-.394;1.69] <.000833>
PSI/DB ; PHI/DA .00728 (.0541) (.430) (-2.17) [-.205;.634] <-.000147>
XD/DB ; PHI/DA .716 (0) (.565) [.374;.783] [.0226;2.00] <.996>

YD/DA ; THE/DB -.156 (-.0587) (.586) [.338;.767] [.0310;4.22] <.0562>
ZD/DB ; PHI/DA .805 (0) (-.147) [-.376;.789] [.0786;2.04] <-.308>
XD/DC ; PHI/DA -.101 (0) (1.01) [-.368;.807] [-.0829;2.06] <-.283>

YD/DP ; THE/DB -.204 (-.0607) (.586) (1.13) (-1.18) [.257;2.40] <-.0557>
ZD/DC ; PHI/DA -3.26 (0) (.615) [-.204;.670] [.393;.773] <-.538>

PHI/DA ; THE/DB ; PSI/DP .0306 (.0442) (-.0597) (.586) <-.472E-4>
PHI/DC ; THE/DB ; PSI/DP .00143 (-.0432) (-.147) (.621) <.565E-5>
THE/DC ; PHI/DA ; PSI/DP -.00421 (-.0265) (.0414) (1.09) <.506E-5>

PSI/DC ; PHI/DA ; THE/DB -.00232 (-.0635) (.113) (.870) <.144E-4>
XD/DB ; PHI/DA ; PSI/DP -.252 (.0441) (.565) [.0240;2.01] <-.0253>
YD/DA ; THE/DB ; PSI/DP .0591 (-.0595) (.585) [.0260;4.07] <-.0340>

ZD/DC ; PHI/DA ; THE/DB .545 (0) (-.0557) [.372;.774] <-.0182>
ZD/DC ; PHI/DA ; PSI/DP 1.15 (.0470) (.644) [-.204;.660] <.0152>
XD/DC ; PHI/DA ; THE/DB -.00889 (0) [.385;.812] <-.00586>

XD/DC ; PHI/DA ; PSI/DP .0362 (.0390) (1.02) [-.0799;2.03] <.00597>
YD/DP ; PHI/DA ; THE/DB -.0697 (-.0599) (.577) (-1.13) (1.17) <-.00319>
ZD/DB ; PHI/DA ; PSI/DP -.283 (.0439) (-.142) [.0745;2.06] <.00753>

ZD/DC ; PHI/DA ; THE/DB ; PSI/DP -.193 (.0463) (-.0575) <.000513>
XD/DC ; PHI/DA ; THE/DB ; PSI/DP .00297 (.0352) <.000105>

TABLE VI-5 CONTINUED
CH-53D TRANSFER FUNCTION FACTORS

CASE 185 40KT AFCS ON

DENOMINATOR: (0) (.0669) (.533) (.714) (1.49) [.601; .449][.578; 1.63][.994; 2.43]<.120>

CONTROL NUMERATORS:

PHI/DA .500 (0) (.0665) (.532) (.714) (1.95) [.502; .418][.545; 1.63]<.0115>
THE/DB -.172 (0) (-.0589) (.586) (1.07) (1.40) (2.04) (3.12) [.600; .447]<.0113>
PSI/DP -.341 (.0689) (.129) (.533) (.556) (.714) (1.49) (3.15) [.574; 1.64]<-.00809>

PHI/DB -.0788 (0) (.326) (.598) (-.625) (1.07) (-1.41) (1.77) [.381; .472]<-.00570>
THE/DA .0768 (0) (-.0101) (-.302) (.627) (.714) (1.97) [.759; .367]<.277E-4>

PHI/DA ; THE/DB -.0865 (0) (-.0587) (.586) (1.07) (1.96) [.501; .417]<.00108>
PHI/DA ; PSI/DP -.177 (.0445) (.0671) (.532) (.556) (.714) [.545; 1.63]<-.000296>
THE/DB ; PSI/DP .0587 (-.0601) (.131) (.556) (.586) (1.07) (1.37) (3.49) <-.000767>

PHI/DB ; PSI/DP .0248 (.0349) (.271) (-.538) (.556) (.604) (1.07) (-1.41) <.635E-4>
PHI/DP ; THE/DB -.0361 (0) (-.0607) (.556) (.586) (1.03) (1.07) (-1.33) <-.00104>
PHI/DC ; THE/DB -.00131 (0) (-.0709) (.608) (1.07) (4.65) [.602; .820]<.000189>

THE/DA ; PSI/DP -.0272 (.00645) (.311) (-.470) (.556) (.624) (.714) <.635E-5>
THE/DP ; PHI/DA -.00345 (0) (.00753) (.556) (.558) (.714) [.202; 1.64]<-.155E-4>
THE/DC ; PHI/DA .0122 (0) (-.0215) (.714) (1.10) (1.90) [.502; .431]<-.728E-4>

PSI/DA ; THE/DB -.00489 (-.0586) (.556) (.590) (1.07) (1.72) [-.394; 1.69] <.000494>
PSI/DB ; PHI/DA .00728 (.0541) (-.470) (.539) (1.07) (-1.78) [-.137; .679] <-.874E-4>
XD/DB ; PHI/DA .716 (0) (.565) (1.07) (1.95) [.501; .418][.0231; 2.01] <.590>

YD/DA ; THE/DB -.156 (-.0587) (.585) (1.07) (1.96) [.444; .411][.0394; 4.19] <.0333>
ZD/DB ; PHI/DA .805 (0) (-.147) (1.07) (1.97) [.505; .419][.0752; 2.05] <-.182>
XD/DC ; PHI/DA -.101 (0) (.714) (.885) (1.93) [.498; .429] [-.0446; 1.84] <-.0766>

YD/DP ; THE/DB -.204 (-.0604) (.556) (.583) (1.04) (1.07) (-1.21) [.547; 3.11] <-.0517>
ZD/DC ; PHI/DA -3.26 (0) (.0486) (.714) (1.94) [.499; .416][.522; 1.64] <-.102>

PHI/DA ; THE/DB ; PSI/DP .0306 (.0442) (-.0597) (.556) (.586) (1.07) <-.280E-4>
PHI/DC ; THE/DB ; PSI/DP .00143 (-.0432) (-.147) (.556) (.621) (1.07) <.335E-5>
THE/DC ; PHI/DA ; PSI/DP -.00421 (-.0265) (.0414) (.556) (.714) (1.09) <.201E-5>

PSI/DC ; PHI/DA ; THE/DB -.00232 (-.0635) (.113) (.556) (.870) (1.07) <.856E-5>
XD/DB ; PHI/DA ; PSI/DP -.252 (.0441) (.556) (.565) (1.07) [.0240; 2.01] <-.0150>
YD/DA ; THE/DB ; PSI/DP .0591 (-.0595) (.556) (.585) (1.07) [.0260; 4.07] <-.0202>

ZD/DC ; PHI/DA ; THE/DB .545 (0) (-.0557) (1.07) (1.95) [.498; .413] <-.0108>
ZD/DC ; PHI/DA ; PSI/DP 1.15 (.556) (.714) [.984; .0486] [.521; 1.64] <.00290>
XD/DC ; PHI/DA ; THE/DB -.00810 (0) (1.07) (2.12) [.520; .435] <-.00348>

XD/DC ; PHI/DA ; PSI/DP .0362 (.0407) (.556) (.714) (.884) [-.0356; 1.83] <.00173>
YD/DP ; PHI/DA ; THE/DB -.0697 (-.0599) (.556) (.577) (1.07) (-1.13) (1.17) <-.00189>
ZD/DB ; PHI/DA ; PSI/DP -.283 (.0439) (-.142) (.556) (1.07) [.0745; 2.06] <.00447>

ZD/DC ; PHI/DA ; THE/DB ; PSI/DP -.193 (.0463) (-.0575) (.556) (1.07) <.000304>
XD/DC ; PHI/DA ; THE/DB ; PSI/DP .00297 (.0352) (.556) (1.07) <.620E-4>

TABLE VI-5 CONTINUED
CH-53D TRANSFER FUNCTION FACTORS

CASE 186 60KT AFCS OFF

DENOMINATOR: (0) (.121) (1.63) [-.240; .306] [.994; .688] [.198; 1.03] <-.00929>
S R P SP D

CONTROL NUMERATORS:

PHI/DA .494 (0) (.507) (.799) [-.246; .325] [.337; .969] <.0199>
 THE/DB -.174 (0) (.0140) (.108) (.649) (1.82) [-.194; 1.03] <-.000328>
 PSI/DP -.361 (.487) (.876) (1.64) [-.345; .330] [.0741; .467] <-.00602>

PHI/DB -.0832 (0) (.228) (-.264) (.909) (-1.59) [.196; .995] <-.00716>
 THE/DA .224 (0) (.447) (.829) (-1.35) (1.43) [-.305; .344] <-.0190>
 PHI/DC .0446 (0) (.419) (.923) [-.451; .434] [.00948; 1.18] <.00448>

THE/DA .0776 (0) (.0250) (-.129) (.649) [.407; .926] <-.000140>
 THE/DP -.00588 (0) (.648) (1.48) [.594; .0301] [-.695; 3.96] <-.803E-4>
 THE/DC .0313 (0) (.00648) (.0744) (.663) (1.97) [.155; 1.05] <.219E-4>

PSI/DA .0302 (.481) [-.228; .320] [.966; 1.22] [-.331; 1.67] <.00609>
 PSI/DB .0171 (.239) (-.388) (1.80) [-.326; .936] [-.397; .956] <-.00229>
 PSI/DC .00768 (.442) (1.94) (3.01) [-.393; .391] [.182; .686] <.00143>

XD/DB 1.30 (0) (.108) (.664) (1.87) [-.194; 1.03] [.0494; 2.02] <.754>
 YD/DA .870 (.535) (.750) [-.239; .327] [.306; .952] [.0193; 4.27] <.617>
 ZD/DC -7.70 (0) (1.69) [-.803; .157] [.338; .526] [.212; 1.01] <-.0913>

XD/DC -.220 (0) (.0709) (.677) (2.11) [.156; 1.05] [.112; 2.04] <-.103>
 YD/DP 1.23 (.460) (.776) (-1.40) (1.43) [-.303; .345] [.250; 2.41] <-.610>
 ZD/DB 2.61 (0) (-.0188) (.110) (1.81) [.193; 1.03] [.120; 2.10] <-.0454>

PHI/DA ; THE/DB -.0863 (0) (.0151) (.650) [.332; .978] <-.000812>
 PHI/DA ; PSI/DP -.185 (.0527) (.484) (.849) [-.281; .336] <-.000453>
 THE/DB ; PSI/DP .0628 (.0130) (.645) (1.82) [-.0358; .448] <.000193>

PHI/DB ; PSI/DP .0262 (.0835) (.754) (-1.62) [-.343; .138] <-.508E-4>
 PHI/DP ; THE/DB -.0394 (0) (.0130) (.644) (-1.35) (1.36) <.000610>
 PHI/DC ; THE/DB -.00514 (0) (.0161) (.982) [.0822; 1.32] <-.000141>

THE/DA ; PSI/DP -.0288 (.0372) (-.449) (-.469) (.636) <.000143>
 THE/DP ; PHI/DA -.00151 (0) (.0374) (.656) [.313; 3.52] <-.000459>
 THE/DC ; PHI/DA .0157 (0) (.0127) (.588) [.302; .989] <.000115>

PSI/DA ; THE/DB -.00514 (.0152) (.652) (1.86) [-.319; 1.63] <-.000250>
 PSI/DB ; PHI/DA .0110 (.0600) (.373) (-.643) [-.139; 1.19] <-.000224>
 PSI/DC ; THE/DB -.00187 (.0161) (1.74) (2.02) [.0643; .653] <-.451E-4>

PSI/DC ; PHI/DA .00245 (.0971) (.460) (5.99) [-.308; .443] <.000129>
 XD/DB ; PHI/DA .644 (0) (.660) [.331; .980] [.0473; 2.06] <1.73>
 XD/DB ; PSI/DP -.466 (.662) (1.87) [-.0378; .448] [.0500; 2.03] <-.477>

YD/DA ; THE/DB -.152 (.0152) (.650) [.299; .960] [.0215; 4.28] <-.0253>
 YD/DA ; PSI/DP -.351 (.485) (.827) [-.272; .339] [.0147; 4.10] <-.273>
 ZD/DC ; PHI/DA -3.82 (0) (.266) [.213; .467] [.353; .957] <-.202>

ZD/DC ; THE/DB 1.25 (0) (.0132) (.106) (1.82) [.195; 1.02] <.00333>
 ZD/DC ; PSI/DP 2.78 (.349) (1.70) [-.122; .342] [.203; .576] <.0639>
 XD/DC ; PHI/DA -.111 (0) (.595) [.290; .995] [.0963; 2.11] <-.290>

XD/DC ; THE/DB -.00236 (0) (.104) (1.43) (-4.70) [.173; 1.06] <.00186>
 XD/DC ; PSI/DP .0805 (.557) (2.11) [.00779; .392] [.127; 2.02] <.0596>
 YD/DP ; PHI/DA .413 (.407) (.986) (-1.50) (1.50) [-.316; .350] <-.0459>

YD/DP ; THE/DB -.214 (.0130) (.645) (1.34) (-1.42) [.263; 2.39] <.0196>
 ZD/DB ; PHI/DA 1.31 (0) (-.0160) [.336; .984] [.117; 2.07] <-.0872>
 ZD/DB ; PSI/DP -.942 (-.0146) (1.81) [-.0443; .446] [.115; 2.10] <.0219>

PHI/DA ; THE/DB ; PSI/DP .0324 (.0121) (.0523) (.646) <.133E-4>
 PHI/DC ; THE/DB ; PSI/DP -.00228 (.0156) (-.0223) (.838) <-.665E-6>
 THE/DC ; PHI/DA ; PSI/DP -.00589 (-.00235) (.0492) (.539) <.368E-6>

TABLE VI-5 CONTINUED
CH-53D TRANSFER FUNCTION FACTORS

CASE 186 60KT AFCS OFF

CONTROL NUMERATORS CONCLUDED:

PSI/DC ; PHI/DA ; THE/DB -.000777 (.0160) (.126) (2.53) <-.397E-5>
 XD/DB ; PHI/DA ; PSI/DP -.240 (.0518) (.661) [.0483; 2.06] <-.0349>
 YD/DA ; THE/DB ; PSI/DP .0612 (.0128) (.645) [.0199; 4.11] <.00855>
 ZD/DC ; PHI/DA ; THE/DB .625 (0) (.0148) [.334; .972] <.00874>
 ZD/DC ; THE/DB ; PSI/DP -.454 (.0121) (1.82) [-.0372; .453] <-.00205>
 ZD/DC ; PHI/DA ; PSI/DP 1.43 (.0573) (.341) [.170; .416] <.00484>
 XD/DC ; PHI/DA ; THE/DB -.00122 (0) (-2.62) [-.299; .772] <.00190>
 XD/DC ; PHI/DA ; PSI/DP .0418 (.0401) (.547) [.103; 2.10] <.00404>
 XD/DC ; THE/DB ; PSI/DP .000533 (1.45) (-9.87) [.0203; .481] <-.00176>
 YD/DP ; PHI/DA ; THE/DB -.0720 (.0123) (.633) (-1.53) (1.57) <.00135>
 ZD/DB ; PHI/DA ; PSI/DP -.491 (-.0142) (.0516) [.112; 2.08] <.00155>
 ZD/DC ; PHI/DA ; THE/DB ; PSI/DP -.235 (.0111) (.0543) <-.000141>
 XD/DC ; PHI/DA ; THE/DB ; PSI/DP .000325 (.0908) (-4.98) <-.000147>

GUST NUMERATORS:

PHI/UG -.00253 (0) (0) (.942) (-1.31) [.614; .747] <.00174>
 THE/UG -.00222 (0) (0) (.126) (.651) (1.88) [.230; .919] <-.000289>
 PSI/UG .00231 (0) (0) (1.69) [-.189; .524] [.813; .722] <.000558>
 PHI/VG .0168 (0) (0) (.392) (.478) (.808) [-.293; .336] <.000289>
 THE/VG .000686 (0) (0) (.418) (.645) (6.08) [.452; .0164] <.303E-6>
 PSI/VG -.00815 (0) (0) (1.73) [-.192; .301] [.971; .657] <-.000553>
 PHI/WG -.00131 (0) (0) (.669) (1.44) (-1.60) [-.209; .297] <.000179>
 THE/WG -.000524 (0) (0) (.0349) (.835) (1.83) [.0479; .402] <-.453E-5>
 PSI/WG .00252 (0) (.683) (1.64) [-.203; .302] [.0653; .485] <.606E-4>
 PHI/PG 1.57 (0) (.639) (.723) [-.181; .303] [.343; .949] <.0599>
 THE/PG -.178 (0) (.0131) (.652) [-.806; .602] [-.164; .926] <-.000473>
 PSI/PG .111 (.593) (.948) (1.22) [-.203; .299] [-.349; 1.63] <.0182>
 PHI/QG .932 (0) (.300) (.872) [-.660; .419] [.336; .941] <.0378>
 THE/QG .448 (0) (.0203) (.0919) (.648) (2.07) [.229; .999] <.00111>
 PSI/QG -.112 (.303) (-.654) (1.98) [-.348; .450] [.679; 1.15] <.0118>
 PHI/RG -.359 (0) (.465) (.828) (-1.33) (1.38) [-.293; .339] <.0293>
 THE/RG -.0743 (0) (.651) (1.42) (-1.71) [.491; .0162] <.306E-4>
 PSI/RG .560 (.505) (.866) (1.64) [-.329; .328] [.0663; .463] <.00929>
 XD/UG .0297 (0) (.127) (.665) (1.88) [.232; .896] [.101; 1.57] <.00929>
 ZD/UG .0891 (0) (0) (.127) (1.78) [.239; .831] [.188; 1.45] <.0292>
 YD/VG .103 (0) (.385) (.501) (.761) [-.291; .337] [.264; 2.33] <.00929>
 XD/WG -.00279 (0) (0) (.958) (-2.13) [.136; .438] [.879; 1.78] <.00347>
 ZD/WG .654 (0) (.123) (.683) (1.64) [-.229; .305] [.208; 1.05] <.00929>
 PHI/UG ; THE/DB .000254 (0) (0) (.561) (-1.17) (1.34) <-.000223>
 PHI/UG ; PSI/DP .000395 (0) (.747) (-1.24) [-.820; .0231] <-.196E-6>
 THE/UG ; PHI/DA -.00111 (0) (0) (.642) [.342; .931] <-.000619>
 THE/UG ; PSI/DP .000815 (0) (.634) (1.82) [-.0297; .445] <.000187>
 PSI/UG ; PHI/DA .00122 (0) (-.00344) (.166) [.729; .534] <-.199E-6>
 PSI/UG ; THE/DB -.000363 (0) (.579) (1.82) [-.00814; .432] <-.713E-4>
 PHI/VG ; THE/DB -.00286 (0) (0) (.0137) (.406) (.627) <-.998E-5>
 PHI/VG ; PSI/DP -.00425 (0) (.448) (.836) [-.308; .343] <-.000187>
 THE/VG ; PHI/DA .000443 (0) (0) (.0365) (.441) (.701) <.501E-5>
 THE/VG ; PSI/DP -.000296 (0) (.653) (4.26) [-.566; .0155] <-.196E-6>
 PSI/VG ; PHI/DA -.00453 (0) (.508) (.788) [-.254; .323] <-.000190>
 PSI/VG ; THE/DB .00140 (0) (.00510) (.00877) (.658) (1.81) <.748E-7>

TABLE VI-5 CONTINUED
CH-53D TRANSFER FUNCTION FACTORS

CASE 186 60KT AFCS OFF

GUST NUMERATORS CONTINUED:

PHI/WG ; THE/DB	.000185	(0)	(.0184)	(-1.61)	(1.80)	<-.982E-5>
PHI/WG ; PSI/DP	-.911E-4	(0)	(-.409)	(1.41)	[.0130;.390]	<.796E-5>
THE/WG ; PHI/DA	-.000267	(0)	(0)	(.0486)	[.437;.736]	<-.702E-5>
THE/WG ; PSI/DP	.000204	(0)	(.0441)	(1.62)	[.0601;.488]	<.346E-5>
PSI/WG ; PHI/DA	.00129	(0)	(.175)	(.590)	[-.237;.308]	<.126E-4>
PSI/WG ; THE/DB	-.000429	(0)	(.0182)	(1.82)	[.0597;.479]	<-.326E-5>
PHI/PG ; THE/DB	-.288	(0)	(.0139)	(.653)	[.333;.976]	<-.00248>
PHI/PG ; PSI/DP	-.592	(.0549)	(.524)	(.873)	[-.259;.328]	<-.00160>
THE/PG ; PHI/DA	-.0781	(0)	(.00228)	(.653)	[.331;.978]	<-.000111>
THE/PG ; PSI/DP	.0649	(.0177)	(.664)	(.830)	[-.451;.858]	<.000464>
PSI/PG ; PHI/DA	.00734	(.0725)	(.363)	(-.955)	[-.312;1.16]	<-.000249>
PSI/PG ; THE/DB	-.0162	(.0139)	(.658)	(1.86)	[-.332;1.66]	<-.000760>
PHI/QG ; THE/DB	-.125	(0)	(.00914)	(.612)	[.378;.827]	<-.000477>
PHI/QG ; PSI/DP	-.311	(.0347)	(.285)	(.792)	[-.511;.379]	<-.000350>
THE/QG ; PHI/DA	.227	(0)	(.0213)	(.655)	[.336;.966]	<.00296>
THE/QG ; PSI/DP	-.162	(.0179)	(.651)	(2.06)	[-.00772;.398]	<-.000621>
PSI/QG ; PHI/DA	-.0837	(.0780)	(.332)	(-.332)	[.349;.861]	<.000534>
PSI/QG ; THE/DB	.0119	(.00897)	(.549)	(-.810)	[.992;1.73]	<-.000142>
PHI/RG ; THE/DB	.0620	(0)	(.0137)	(.664)	(-1.34)	(1.34) <-.00101>
PHI/RG ; PSI/DP	.00407	(.822)	[.435;.221]	[-.998;.469]	<.359E-4>	
THE/RG ; PHI/DA	-.00477	(0)	(.0360)	(.633)	(-2.11)	(2.22) <.000507>
THE/RG ; PSI/DP	.00515	(.0415)	(.751)	(1.91)	[-.0193;.445]	<.605E-4>
PSI/RG ; PHI/DA	.288	(.0556)	(.491)	(.844)	[-.274;.333]	<.000735>
PSI/RG ; THE/DB	-.0972	(.0137)	(.660)	(1.82)	[-.0337;.448]	<-.000321>
XD/UG ; PHI/DA	.0148	(0)	(.656)	[.338;.911]	[.109;1.57]	<.0199>
XD/UG ; THE/DB	-.00228	(0)	(.109)	(.682)	(1.88)	[.215;1.01] <-.000328>
XD/UG ; PSI/DP	-.0104	(.656)	(1.83)	[-.0358;.444]	[.0991;1.56]	<-.00602>
ZD/UG ; PHI/DA	.0448	(0)	(0)	[.307;.883]	[.246;1.34]	<.0627>
ZD/UG ; THE/DB	-.00969	(0)	(0)	(.116)	(1.82)	[.232;1.10] <-.00245>
ZD/UG ; PSI/DP	-.0322	(0)	(1.76)	[-.0465;.440]	[.183;1.31]	<-.0190>
YD/VG ; PHI/DA	.0362	(0)	(.868)	[-.300;.341]	[.992;.448]	<.000735>
YD/VG ; THE/DB	-.0178	(0)	(.0137)	(.399)	(.634)	[.275;2.28] <-.000321>
YD/VG ; PSI/DP	-.0271	(.461)	(.789)	[-.306;.344]	[.274;2.27]	<-.00602>
XD/WG ; PHI/DA	-.00133	(0)	(0)	(-2.02)	(3.01)	[.445;.760] <.00468>
XD/WG ; THE/DB	.00116	(0)	(0)	(.106)	(1.82)	[.145;1.05] <.000245>
XD/WG ; PSI/DP	.00133	(0)	(1.59)	(-1.82)	(2.81)	[.0620;.485] <-.00256>
ZD/WG ; PHI/DA	.323	(0)	(.624)	[-.226;.320]	[.345;.983]	<.0199>
ZD/WG ; THE/DB	-.112	(0)	(.0140)	(.108)	(1.82)	[-.200;1.03] <-.000328>
ZD/WG ; PSI/DP	-.236	(.683)	(1.64)	[-.303;.324]	[.0696;.465]	<-.00602>
XD/UG ; ZD/DC	-.209	(0)	(.129)	(1.86)	[.236;.867]	[.105;1.56] <-.0913>
YD/VG ; ZD/DC	-.791	(0)	(.312)	(.379)	[.121;.421]	[.265;2.34] <-.0913>
PHI/UG ; THE/DB ; PSI/DP	-.954E-5	(0)	(.148)	(1.12)	<-.157E-5>	
THE/UG ; PHI/DA ; PSI/DP	.000421	(0)	(.0527)	(.634)	<.141E-4>	
PSI/UG ; PHI/DA ; THE/DB	-.000188	(0)	(.0623)	(.593)	<-.695E-5>	
PHI/VG ; THE/DB ; PSI/DP	.000718	(0)	(.0130)	(.643)	<.601E-5>	
THE/VG ; PHI/DA ; PSI/DP	-.000180	(0)	(.0374)	(.665)	<-.448E-5>	
PSI/VG ; PHI/DA ; THE/DB	.000782	(0)	(.0152)	(.655)	<.778E-5>	
PHI/WG ; THE/DB ; PSI/DP	.306E-4	(0)	(.0139)	(-.666)	<-.284E-6>	
THE/WG ; PHI/DA ; PSI/DP	.000104	(0)	(.0387)	(.112)	<.450E-6>	
PSI/WG ; PHI/DA ; THE/DB	-.000219	(0)	(.0164)	(.165)	<-.593E-6>	

TABLE VI-5 CONTINUED
CH-53D TRANSFER FUNCTION FACTORS

CASE 186 60KT AFCS OFF

GUST NUMERATORS CONCLUDED:

PHI/PG ; THE/DB ; PSI/DP	.108 (.0127) (.0535) (.647) <.473E-4>
THE/PG ; PHI/DA ; PSI/DP	.0293 (-.00323) (.0520) (.651) <-.321E-5>
PSI/PG ; PHI/DA ; THE/DB	.000452 (.0378) [.617; .723] <.891E-5>
PHI/QG ; THE/DB ; PSI/DP	.0424 (.0147) (.0415) (.635) <.164E-4>
THE/QG ; PHI/DA ; PSI/DP	-.0854 (.0190) (.0518) (.654) <-.550E-4>
PSI/QG ; PHI/DA ; THE/DB	.00958 (.777) [.671; .0393] <.115E-4>
PHI/RG ; THE/DB ; PSI/DP	-.000334 (.0161) [.419; .555] <-.166E-5>
THE/RG ; PHI/DA ; PSI/DP	.00267 (.0395) (.0663) (.773) <.540E-5>
PSI/RG ; PHI/DA ; THE/DB	-.0502 (.0133) (.0554) (.659) <-.243E-4>
XD/UG ; PHI/DA ; THE/DB	-.00113 (0) (.670) [.313; 1.03] <-.000812>
XD/UG ; PHI/DA ; PSI/DP	-.00537 (.0529) (.655) [.102; 1.56] <-.000453>
XD/UG ; THE/DB ; PSI/DP	.000764 (.684) (1.83) [-.0369; .450] <.000193>
ZD/UG ; PHI/DA ; THE/DB	-.00487 (0) (0) [.375; 1.04] <-.00527>
ZD/UG ; PHI/DA ; PSI/DP	-.0166 (0) (.0531) [.182; 1.27] <-.00143>
ZD/UG ; THE/DB ; PSI/DP	.00348 (0) (1.82) [-.0404; .451] <.00129>
YD/VG ; PHI/DA ; THE/DB	-.00636 (0) (.0133) [.993; .535] <-.243E-4>
YD/VG ; PHI/DA ; PSI/DP	-.00979 (.405) (.938) [-.320; .349] <-.000453>
YD/VG ; THE/DB ; PSI/DP	.00472 (.0130) (.645) [.284; 2.21] <.000193>
XD/WG ; PHI/DA ; THE/DB	.000580 (0) (0) [.418; .849] <.000418>
XD/WG ; PHI/DA ; PSI/DP	.000685 (0) (.106) (-1.88) (2.61) <-.000356>
XD/WG ; THE/DB ; PSI/DP	-.000495 (0) (1.90) [-.0179; .452] <-.000192>
ZD/WG ; PHI/DA ; THE/DB	-.0558 (0) (.0151) [.339; .981] <-.000812>
ZD/WG ; PHI/DA ; PSI/DP	-.121 (.0530) (.646) [-.237; .331] <-.000453>
ZD/WG ; THE/DB ; PSI/DP	.0405 (.0130) (1.82) [-.0371; .449] <.000193>
XD/UG ; ZD/DC ; PHI/DA	-.104 (0) [.334; .895] [.114; 1.56] <-.202>
XD/UG ; ZD/DC ; THE/DB	.0166 (0) (.106) (1.86) [.219; 1.01] <.00333>
XD/UG ; ZD/DC ; PSI/DP	.0732 (1.81) [-.0400; .451] [.102; 1.54] <.0639>
YD/VG ; ZD/DC ; PHI/DA	-.279 (0) (.307) (.487) [.132; .415] <-.00718>
YD/VG ; ZD/DC ; THE/DB	.129 (0) (.0128) (.374) [.276; 2.30] <.00324>
YD/VG ; ZD/DC ; PSI/DP	.209 (.355) [.0514; .405] [.271; 2.29] <.0639>
XD/UG ; PHI/DA ; THE/DB ; PSI/DP	.000394 (.0497) (.680) <.133E-4>
ZD/UG ; PHI/DA ; THE/DB ; PSI/DP	.00180 (0) (.0502) <.901E-4>
YD/VG ; PHI/DA ; THE/DB ; PSI/DP	.00173 (.0123) (.623) <.133E-4>
XD/WG ; PHI/DA ; THE/DB ; PSI/DP	-.000255 (0) (.0949) <-.242E-4>
ZD/WG ; PHI/DA ; THE/DB ; PSI/DP	.0209 (.0121) (.0525) <.133E-4>
XD/UG ; ZD/DC ; PHI/DA ; THE/DB	.00827 (0) [.310; 1.03] <.00874>
YD/VG ; ZD/DC ; PHI/DA ; THE/DB	.0458 (0) (.0123) (.429) <.000242>
YD/VG ; ZD/DC ; PHI/DA ; PSI/DP	.0752 (.419) [.0729; .392] <.00484>
XD/WG ; ZD/DC ; PHI/DA ; THE/DB	-.00342 (0) [.479; .746] <-.00190>
XD/UG ; ZD/DC ; PHI/DA ; THE/DB ; PSI/DP	-.00287 (.0492) <-.000141>
YD/VG ; ZD/DC ; PHI/DA ; THE/DB ; PSI/DP	-.0125 (.0113) <-.000141>
XD/WG ; ZD/DC ; PHI/DA ; THE/DB ; PSI/DP	.00163 (.0901) <.000147>

TABLE VI-5 CONTINUED
CH-53D TRANSFER FUNCTION FACTORS

CASE 186 60KT AFCS ON

DENOMINATOR: (0) (.0399) (.668) (.714) (3.44) [.604; .574] [.988; 1.55] [.623; 1.60] [.132]

S SD A HD A RA SP

CONTROL NUMERATORS:

PHI/DA .494 (0) (.0398) (.667) (.714) (1.94) [.552; .525] [.590; 1.60] <.0129>

THE/DB -.174 (0) (.0151) (.646) (1.07) (3.78) [.599; .570] [.995; 1.49] <-.00494>

PSI/DP -.361 (.0401) (.132) (.556) (.668) (.714) (1.51) (3.12) [.618; 1.61] <-.00616>

PHI/DB -.0832 (0) (.214) (-.255) (.700) (1.07) (-1.60) (1.74) [.411; .671] <-.00428>

PHI/DP .224 (0) (.0401) (.556) (.668) (.714) (1.30) (-1.47) [.584; 1.58] <-.0113>

PHI/DC .0446 (0) (.0494) (.714) (.715) (1.79) [.502; .794] [.197; 1.45] <.00266>

THE/DA .0787 (0) (.0246) (-.151) (.629) (.714) (1.87) [.844; .484] <-.577E-4>

THE/DP -.00588 (0) (.0381) (.556) (.668) (.714) [.992; 1.12] [-.485; 4.94] <-.00182>

THE/DC .0313 (0) (.0125) (.536) (.714) (1.40) (1.53) (4.03) [.564; .595] <.000455>

PSI/DA .0302 (.0398) (.555) (.680) (.714) (5.61) [.0160; .885] [.634; 1.66] <.00395>

PSI/DB .0171 (.112) (-.536) (1.07) [1.00; .517] [.0500; 1.28] [.898; 2.36] <-.00267>

PSI/DC .00768 (.0474) (.311) (.556) (.714) (6.15) [.639; 1.26] [.825; 1.91] <.00159>

XD/DB 1.30 (0) (.661) (1.07) (3.87) [.602; .574] [.000; 1.47] [.0415; 2.05] <10.5>

YD/DA .870 (.0398) (.664) (.714) (1.92) [.510; .512] [.589; 1.60] [-.0196; 4.33] <.400>

ZD/DC -7.70 (0) (.0341) (.714) (3.51) [.603; .573] [.990; 1.52] [.578; 1.65] <-1.37>

XD/DC -.220 (0) (.620) (.714) (1.22) (1.54) (4.23) [.600; .585] [.0595; 2.14] <-1.30>

YD/DP 1.23 (.0401) (.556) (.668) (.714) (1.31) (-1.50) [.590; 1.55] [.528; 3.17] <-1.624>

ZD/DB 2.61 (0) (-.0162) (1.07) (3.80) [.607; .573] [.995; 1.49] [.122; 2.08] <-1.536>

PHI/DA ; THE/DB -.0863 (0) (.0151) (.645) (1.07) (1.96) [.547; .522] <-.000482>

PHI/DA ; PSI/DP -.185 (.0403) (.0516) (.556) (.666) (.714) [.587; 1.60] <-.000261>

THE/DB ; PSI/DP .0628 (.0127) (.132) (.556) (.647) (1.07) (1.38) (3.47) <.000193>

PHI/DB ; PSI/DP .0262 (.0835) (.556) (.714) (1.07) (-1.62) [-.343; .138] <-.301E-4>

PHI/DP ; THE/DB -.0394 (0) (.0130) (.556) (.644) (1.07) (1.26) (-1.47) <.000364>

PHI/DC ; THE/DB -.00514 (0) (-.0161) (.738) (1.07) (1.87) [.452; .834] <-.845E-4>

THE/DA ; PSI/DP -.0288 (.0372) (.449) (-.469) (.556) (.636) (.714) <.569E-4>

THE/DP ; PHI/DA -.00151 (0) (.0374) (.556) (.656) (.714) [.313; 3.52] <-.000182>

THE/DC ; PHI/DA .0157 (0) (-.0127) (.541) (.714) (1.97) [.506; .548] <.454E-4>

PSI/DA ; THE/DB -.00514 (.0152) (.556) (.650) (1.07) (6.42) [.0186; .876] <-.000148>

PSI/DB ; PHI/DA .0110 (.0600) (.385) (.545) (-.604) (1.07) [-.0487; 1.22] <-.000133>

PSI/DC ; THE/DB -.00187 (.0160) (.296) (.556) (1.07) (4.65) [.897; 1.43] <-.501E-4>

PSI/DC ; PHI/DA .00245 (.0443) (.142) (.556) (.714) (7.03) [.554; 1.32] <.755E-4>

XD/DB ; PHI/DA .644 (0) (.662) (1.07) (1.94) [.551; .524] [.0475; 2.06] <1.03>

XD/DB ; PSI/DP -.466 (.132) (.556) (.661) (1.07) (1.35) (3.56) [.0423; 2.05] <-1.488>

YD/DA ; THE/DB -.152 (.0152) (.644) (1.07) (1.94) [.504; .509] [-.0154; 4.35] <-.0150>

YD/DA ; PSI/DP -.351 (.0401) (.556) (.662) (.714) [.583; 1.60] [.0139; 4.11] <-1.161>

ZD/DC ; PHI/DA -3.82 (0) (.0340) (.714) (1.95) [.548; .524] [.552; 1.64] <-1.134>

ZD/DC ; THE/DB 1.25 (0) (.0148) (1.07) (3.78) [.602; .565] [.995; 1.49] <.0530>

ZD/DC ; PSI/DP 2.78 (.0347) (.133) (.556) (.714) (1.45) (3.22) [.572; 1.66] <.0655>

XD/DC ; PHI/DA -.111 (0) (.633) (.714) (1.94) [.533; .529] [.0565; 2.16] <-1.127>

XD/DC ; THE/DB -.00236 (0) (1.07) (3.01) (-4.16) [.635; .406] [.941; 1.54] <.0123>

XD/DC ; PSI/DP .0805 (.131) (.556) (.618) (.714) (1.25) (4.06) [.0669; 2.13] <.0593>

YD/DP ; PHI/DA .413 (.0401) (.556) (.682) (.714) (-1.52) (1.52) [.592; 1.60] <-.0264>

YD/DP ; THE/DB -.214 (.0127) (.556) (.641) (1.07) (1.27) (-1.51) [.548; 3.14] <.0195>

ZD/DB ; PHI/DA 1.31 (0) (-.0160) (1.07) (1.97) [.554; .523] [.114; 2.07] <-.0517>

ZD/DB ; PSI/DP -.942 (-.0144) (.133) (.556) (1.07) (1.38) (3.47) [.119; 2.08] <.0221>

PHI/DA ; THE/DB ; PSI/DP .0324 (.0121) (.0523) (.556) (.646) (1.07) <.789E-5>

PHI/DC ; THE/DB ; PSI/DP .00228 (.0156) (-.0223) (.556) (.838) (1.07) <-.394E-6>

THE/DC ; PHI/DA ; PSI/DP -.00589 (-.00235) (.0492) (.539) (.556) (.714) <.146E-6>

TABLE VI-5 CONTINUED
CH-53D TRANSFER FUNCTION FACTORS

CASE 186 60KT AFCS ON

CONTROL NUMERATORS CONCLUDED:

PSI/DC ; PHI/DA ; THE/DB -.000777 (.0160) (.126) (.556) (1.07) (2.53) <-.235E-5>

XD/DB ; PHI/DA ; PSI/DP -.240 (.0518) (.556) (.661) (1.07) [.0483; 2.06] <-.0207>

YD/DA ; THE/DB ; PSI/DP .0612 (.0128) (.556) (.645) (1.07) [.0199; 4.11] <.00507>

ZD/DC ; PHI/DA ; THE/DB .625 (0) (.0148) (1.07) (1.96) [.548; .517] <.00519>

ZD/DC ; THE/DB ; PSI/DP -.454 (.0117) (.136) (.556) (1.07) (1.38) (3.47) <-.00205>

ZD/DC ; PHI/DA ; PSI/DP 1.43 (.0352) (.0515) (.556) (.714) [.549; 1.65] <.00278>

XD/DC ; PHI/DA ; THE/DB -.00122 (0) (1.07) (2.03) (-3.05) [.477; .375] <.00113>

XD/DC ; PHI/DA ; PSI/DP .0418 (.0508) (.556) (.636) (.714) [.0618; 2.16] <.00250>

XD/DC ; THE/DB ; PSI/DP .000533 (.216) (.556) (1.07) (-8.32) [.949; 1.83] <-.00191>

YD/DP ; PHI/DA ; THE/DB -.0720 (.0123) (.556) (.633) (1.07) (-1.53) (1.57) <.000799>

ZD/DB ; PHI/DA ; PSI/DP -.491 (-.0142) (.0516) (.556) (1.07) [.112; 2.08] <.000920>

ZD/DC ; PHI/DA ; THE/DB ; PSI/DP -.285 (.0141) (.0543) (.556) (1.07) <-.836E-4>

XD/DC ; PHI/DA ; THE/DB ; PSI/DP .000325 (.0908) (.556) (1.07) (-4.98) <-.872E-4>

GUST NUMERATORS:

PHI/UG -.00253 (0) (0) (.386) (.699) (.714) (-1.28) (1.55) [.427; 1.19] <.00137>

THE/UG -.00222 (0) (0) (.633) (.714) (4.09) [.577; .542] [.992; 1.45] <-.00254>

PSI/UG .00231 (0) (.127) (.714) (1.82) (2.79) [.000; .569] [.566; 1.58] <.000856>

PHI/VG -.0168 (0) (0) (.0401) (.112) (.668) (.714) (1.66) [.568; 1.57] <.000148>

THE/VG .00704 (0) (0) (.0371) (.115) (.691) (.714) (.866) (1.60) <.205E-4>

PSI/VG -.00815 (0) (.0399) (.556) (.672) (.714) [.606; 1.61] [.994; 2.33] <-.00122>

PHI/WG -.00131 (0) (0) (.0407) (.714) (.799) (1.18) (-1.91) [.532; 1.39] <.000133>

THE/WG -.000524 (0) (0) (.0475) (.714) (4.80) [.557; .420] [.975; 1.40] <-.293E-4>

PSI/WG .00252 (0) (.0403) (.272) (.557) (.714) (1.48) (3.13) [.607; 1.60] <.000129>

PHI/PG 1.57 (0) (.0361) (.666) (.714) (1.97) [.560; .529] [.628; 1.62] <.0389>

THE/PG -.178 (0) (.00306) (.646) (.714) (2.02) [.661; .601] [.694; 1.85] <-.000629>

PSI/PG .111 (-.0342) (.554) (.699) (.714) (5.17) [.0236; .870] [.630; 1.59] <.0103>

PHI/QG .932 (0) (.0581) (.673) (.714) (1.81) [.449; .431] [.401; 1.43] <.0180>

THE/QG .448 (0) (.0213) (.656) (.714) (1.27) (1.61) (4.25) [.588; .556] <.0120>

PSI/QG -.112 (.0562) (-.233) (.562) (.633) (.714) [.410; 1.71] [.820; 2.53] <.00695>

PHI/RG -.359 (0) (.0401) (.572) (.657) (.714) (1.32) (-1.44) [.579; 1.56] <.0179>

THE/RG -.120 (0) (.0369) (.426) (.714) (.737) (-1.46) [.988; 1.17] <.00199>

PSI/RG .560 (.0401) (.136) (.556) (.678) (.714) (1.52) (3.11) [.617; 1.60] <.0100>

XD/UG .0297 (0) (.659) (.714) (4.02) [.593; .570] [.995; 1.42] [.240; 1.89] <.132>

ZD/UG .0891 (0) (0) (.714) (3.82) [.616; .570] [.990; 1.48] [.390; 1.85] <.589>

YD/VG .103 (0) (.0401) (.125) (.666) (.714) (1.66) [.578; 1.53] [.564; 3.10] <.00920>

XD/WG -.00279 (0) (0) (.249) (.714) [.426; .621] [.977; 1.22] [.783; 4.97] <-.00701>

ZD/WG .654 (0) (.0399) (.714) (3.49) [.605; .573] [.986; 1.53] [.614; 1.63] <.132>

PHI/UG ; THE/DR .000254 (0) (0) (.461) (.696) (1.07) (-1.20) (1.27) <-.000133>

PHI/UG ; PSI/DP .000395 (0) (.108) (.556) (.714) (.782) [-.721; .849] <.953E-5>

THE/UG ; PHI/DA -.00111 (0) (0) (.633) (.714) (2.00) [.536; .494] <-.000246>

THE/UG ; PSI/DP .000815 (0) (.132) (.556) (.634) (.714) (1.38) (3.49) <.000130>

PSI/UG ; PHI/DA .00122 (0) (.0610) (.714) [.999; .555] [.506; 1.61] <.424E-4>

PSI/UG ; THE/DR -.000363 (0) (.134) (.556) (.605) (1.07) (1.38) (3.45) <-.831E-4>

PHI/VG ; THE/DB -.00286 (0) (0) (.0133) (.112) (.643) (1.07) (1.64) <-.484E-5>

PHI/VG ; PSI/DP -.00425 (0) (.0401) (.556) (.666) (.714) [.560; 1.57] <-.000111>

THE/VG ; PHI/DA .000443 (0) (0) (.0363) (.114) (.664) (.714) (2.35) <.205E-5>

THE/VG ; PSI/DP -.000296 (0) (.0381) (.556) (.708) (.714) (.780) (7.17) <-.177E-4>

PSI/VG ; PHI/DA -.00453 (0) (.0398) (.556) (.666) (.714) [.578; 1.60] <-.000123>

PSI/VG ; THE/DB .00140 (0) (.0152) (.556) (.652) (1.07) (1.92) (2.89) <.458E-4>

TABLE VI-5 CONTINUED
CH-53D TRANSFER FUNCTION FACTORS

CASE 186 60KT AFCS ON

GUST NUMERATORS CONTINUED:

PHI/WG ; THE/DB	.000185	{0}	{0}	{.0183}	{1.07}	{-1.94}	[.974; .919]	<-.591E-5>	
PHI/WG ; PSI/DP	-.911E-4	{0}	{.0401}	{.556}	{-.615}	{.714}	[.930; 2.34]	<.490E-5>	
THE/WG ; PHI/DA	-.000267	{0}	{0}	{.0487}	{.714}	{2.15}	[.564; .374]	<-.279E-5>	
THE/WG ; PSI/DP	.000204	{0}	{.0419}	{.193}	{.556}	{.714}	{1.58}	{3.06}	<.314E-5>
PSI/WG ; PHI/DA	.00129	{0}	{.0400}	{.163}	{.557}	{.714}	[.568; 1.61]	<.863E-5>	
PSI/WG ; THE/DB	-.000429	{0}	{.0170}	{.276}	{.556}	{1.07}	{1.28}	{3.54}	<-.542E-5>
PHI/PG ; THE/DB	-.288	{0}	{.0139}	{.646}	{1.07}	{1.96}	[.548; .523]	<-.00147>	
PHI/PG ; PSI/DP	-.592	{.556}	{.663}	{.714}	[.000; .0471]	[.620; 1.63]	<-.000924>		
THE/PG ; PHI/DA	-.0781	{0}	{.00228}	{.650}	{.714}	{1.96}	[.546; .522]	<-.442E-4>	
THE/PG ; PSI/DP	.0649	{.0131}	{-.188}	{.556}	{.648}	{.714}	[.658; 2.04]	<.000171>	
PSI/PG ; PHI/DA	.00734	{.0551}	{.487}	{.531}	{.714}	{-1.98}	[.0252; 1.02]	<-.000153>	
PSI/PG ; THE/DB	-.0162	{.0128}	{.556}	{.646}	{1.07}	{6.53}	[-.00427; .875]	<-.000398>	
PHI/QG ; THE/DB	-.125	{0}	{.00910}	{.638}	{1.07}	{1.87}	[.525; .442]	<-.000281>	
PHI/QG ; PSI/DP	-.311	{.0274}	{.0530}	{.556}	{.679}	{.714}	[.388; 1.40]	<-.000239>	
THE/QG ; PHI/DA	.227	{0}	{.0213}	{.654}	{.714}	{1.97}	[.546; .513]	<.00118>	
THE/QG ; PSI/DP	-.162	{.0183}	{.122}	{.556}	{.656}	{.714}	{1.24}	{3.95}	<-.000463>
PSI/QG ; PHI/DA	-.0837	{.0528}	{-.0539}	{.714}	[.999; .566]	[.353; 1.61]	<-.000141>		
PSI/QG ; THE/DB	.0119	{.00232}	{-.160}	{.556}	{.680}	{1.07}	[.729; 3.07]	<-.167E-4>	
PHI/RG ; THE/DB	.0620	{0}	{.0137}	{1.07}	{1.27}	{-1.44}	[.999; .602]	<-.000603>	
PHI/RG ; PSI/DP	.00407	{.0402}	{.556}	{.714}	[.810; .628]	[-.156; .976]	<.244E-4>		
THE/RG ; PHI/DA	-.00477	{0}	{.0360}	{.437}	{.713}	{.714}	{-1.47}	{3.59}	<.000201>
THE/RG ; PSI/DP	.00515	{.0410}	{.145}	{.556}	{.714}	{.794}	{1.30}	{3.61}	<.452E-4>
PSI/RG ; PHI/DA	.288	{.0403}	{.0551}	{.556}	{.677}	{.714}	[.585; 1.60]	<.000440>	
PSI/RG ; THE/DB	-.0972	{.0135}	{.136}	{.556}	{.657}	{1.07}	{1.38}	{3.46}	<-.000333>
XD/UG ; PHI/DA	.0148	{0}	{.660}	{.714}	{1.93}	[.555; .517]	[.242; 1.89]	<.0129>	
XD/UG ; THE/DB	-.00228	{0}	{.683}	{1.07}	{3.97}	[.605; .644]	[.989; 1.34]	<-.00494>	
XD/UG ; PSI/DP	-.0104	{.132}	{.556}	{.659}	{.714}	{1.37}	{3.47}	[.242; 1.89]	<-.00616>
ZD/UG ; PHI/DA	.0448	{0}	{0}	{.714}	{2.00}	[.569; .520]	[.378; 1.82]	<.0571>	
ZD/UG ; THE/DB	-.00969	{0}	{0}	{1.07}	{3.80}	[.643; .603]	[.996; 1.50]	<-.0322>	
ZD/UG ; PSI/DP	-.0322	{0}	{.132}	{.556}	{.714}	{1.41}	{3.33}	[.387; 1.82]	<-.0265>
YD/VG ; PHI/DA	.0362	{0}	{.0401}	{.144}	{.671}	{.714}	{1.77}	[.591; 1.59]	<.000450>
YD/VG ; THE/DB	-.0178	{0}	{.0133}	{.125}	{.639}	{1.07}	{1.65}	[.594; 3.01]	<-.000301>
YD/VG ; PSI/DP	-.0271	{.0401}	{.556}	{.664}	{.714}	[.571; 1.52]	[.575; 3.05]	<-.00616>	
XD/WG ; PHI/DA	-.00133	{0}	{.376}	{.714}	{1.88}	{5.10}	[.308; .453]	<-.000700>	
XD/WG ; THE/DB	.00116	{0}	{0}	{1.07}	{1.30}	{2.44}	{3.25}	[.660; .450]	<.00259>
XD/WG ; PSI/DP	.00133	{0}	{.0872}	{.252}	{.556}	{.714}	{1.74}	{4.13}	<.000225>
ZD/WG ; PHI/DA	.323	{0}	{.0398}	{.714}	{1.96}	[.553; .523]	[.582; 1.62]	<.0129>	
ZD/WG ; THE/DB	-.112	{0}	{.0151}	{1.07}	{3.78}	[.606; .570]	[.995; 1.49]	<-.00494>	
ZD/WG ; PSI/DP	-.236	{.0401}	{.132}	{.556}	{.714}	{1.51}	{3.12}	[.610; 1.62]	<-.00616>
XD/UG ; ZD/DC	-.209	{0}	{.714}	{4.00}	[.588; .565]	[.992; 1.42]	[.250; 1.88]	<-1.37>	
YD/VG ; ZD/DC	-.791	{0}	{.0335}	{.120}	{.714}	{1.66}	[.548; 1.58]	[.562; 3.10]	<-.0906>
PHI/UG ; THE/DB ; PSI/DP	-.954E-5	{0}	{.148}	{.556}	{1.07}	{1.12}	<-.932E-6>		
THE/UG ; PHI/DA ; PSI/DP	.000421	{0}	{.0527}	{.556}	{.634}	{.714}	<.558E-5>		
PSI/UG ; PHI/DA ; THE/DB	-.000188	{0}	{.0623}	{.556}	{.593}	{1.07}	<-.412E-5>		
PHI/VG ; THE/DB ; PSI/DP	.000718	{0}	{.0130}	{.556}	{.643}	{1.07}	<.356E-5>		
THE/VG ; PHI/DA ; PSI/DP	-.000180	{0}	{.0374}	{.556}	{.665}	{.714}	<-.178E-5>		
PSI/VG ; PHI/DA ; THE/DB	.000782	{0}	{.0152}	{.556}	{.655}	{1.07}	<.461E-5>		
PHI/WG ; THE/DB ; PSI/DP	.306E-4	{0}	{.0139}	{.556}	{-.666}	{1.07}	<-.169E-6>		
THE/WG ; PHI/DA ; PSI/DP	.000104	{0}	{.0387}	{.112}	{.556}	{.714}	<.179E-6>		
PSI/WG ; PHI/DA ; THE/DB	-.000219	{0}	{.0164}	{.165}	{.556}	{1.07}	<-.351E-6>		

TABLE VI-5 CONTINUED
CH-53D TRANSFER FUNCTION FACTORS

CASE 186 60KT AFCS ON

GUST NUMERATORS CONCLUDED:

PHI/PG ; THE/DB ; PSI/DP	.108 (.0127) (.0535) (.556) (.647) (1.07) <.281E-4>
THE/PG ; PHI/DA ; PSI/DP	.0293 (-.00323) (.0520) (.556) (.651) (.714) <-.218E-4>
PSI/PG ; PHI/DA ; THE/DB	.000452 (.0378) (.556) (1.07) [.617; .723] <.528E-5>
PHI/QG ; THE/DB ; PSI/DP	.0424 (.0147) (.0415) (.556) (.635) (1.07) <.975E-5>
THE/QG ; PHI/DA ; PSI/DP	-.0854 (.0190) (.0518) (.556) (.654) (.714) <-.218E-4>
PSI/QG ; PHI/DA ; THE/DB	.00958 (.556) (.777) (1.07) [.671; .0393] <.682E-5>
PHI/RG ; THE/DB ; PSI/DP	-.000334 (.0161) (.556) (1.07) [.419; .555] <-.985E-6>
THE/RG ; PHI/DA ; PSI/DP	.00267 (.0395) (.0663) (.556) (.714) (.773) <.214E-5>
PSI/RG ; PHI/DA ; THE/DB	-.0502 (.0133) (.0554) (.556) (.659) (1.07) <-.144E-4>
XD/UG ; PHI/DA ; THE/DB	-.00113 (0) (.684) (1.07) (1.76) [.570; .576] <-.000482>
XD/UG ; PHI/DA ; PSI/DP	-.00537 (.0519) (.556) (.660) (.714) [.243; 1.89] <-.000261>
XD/UG ; THE/DB ; PSI/DP	.000764 (.131) (.556) (.677) (1.07) (1.37) (3.48) <.000193>
ZD/UG ; PHI/DA ; THE/DB	-.00487 (0) (0) (1.07) (1.99) [.588; .550] <-.00312>
ZD/UG ; PHI/DA ; PSI/DP	-.0166 (0) (.0516) (.556) (.714) [.374; 1.81] <-.00112>
ZD/UG ; THE/DB ; PSI/DP	.00348 (0) (.131) (.556) (1.07) (1.38) (3.47) <.00129>
YD/VG ; PHI/DA ; THE/DB	-.00636 (0) (.0133) (.143) (.625) (1.07) (1.81) <-.147E-4>
YD/VG ; PHI/DA ; PSI/DP	-.00979 (.0401) (.556) (.668) (.714) [.592; 1.58] <-.000261>
YD/VG ; THE/DB ; PSI/DP	.00472 (.0137) (.556) (.638) (1.07) [.607; 2.91] <.000193>
XD/WG ; PHI/DA ; THE/DB	.000581 (0) (0) (1.07) (2.34) [.567; .414] <.000248>
XD/WG ; PHI/DA ; PSI/DP	.000685 (0) (.0209) (.314) (.556) (.714) (3.57) <.638E-5>
XD/WG ; THE/DB ; PSI/DP	-.000495 (0) (.187) (.556) (1.07) (1.30) (3.58) <-.000256>
ZD/WG ; PHI/DA ; THE/DB	-.0558 (0) (.0151) (1.07) (1.96) [.553; .522] <-.000482>
ZD/WG ; PHI/DA ; PSI/DP	-.121 (.0404) (.0516) (.556) (.714) [.580; 1.62] <-.000261>
ZD/WG ; THE/DB ; PSI/DP	.0405 (.0127) (.132) (.556) (1.07) (1.38) (3.47) <.000193>
XD/UG ; ZD/DC ; PHI/DA	-.104 (0) (.714) (1.93) [.552; .513] [.251; 1.88] <-.134>
XD/UG ; ZD/DC ; THE/DB	.0166 (0) (1.07) (3.95) [.595; .640] [.987; 1.36] <.0530>
XD/UG ; ZD/DC ; PSI/DP	.0732 (.134) (.556) (.714) (1.39) (3.43) [.252; 1.88] <.0655>
YD/VG ; ZD/DC ; PHI/DA	-.279 (0) (.0336) (.137) (.714) (1.79) [.549; 1.64] <-.00444>
YD/VG ; ZD/DC ; THE/DB	.129 (0) (.0123) (.118) (1.07) (1.65) [.590; 3.02] <.00300>
YD/VG ; ZD/DC ; PSI/DP	.209 (.0346) (.556) (.714) [.544; 1.57] [.571; 3.04] <.0655>
XD/UG ; PHI/DA ; THE/DB ; PSI/DP	.000394 (.0497) (.556) (.680) (1.07) <.789E-5>
ZD/UG ; PHI/DA ; THE/DB ; PSI/DP	.00180 (0) (.0502) (.556) (1.07) <.534E-4>
YD/VG ; PHI/DA ; THE/DB ; PSI/DP	.00173 (.0123) (.556) (.623) (1.07) <.789E-5>
XD/WG ; PHI/DA ; THE/DB ; PSI/DP	-.000255 (0) (.0949) (.556) (1.07) <-.143E-4>
ZD/WG ; PHI/DA ; THE/DB ; PSI/DP	.0209 (.0121) (.0525) (.556) (1.07) <.789E-5>
XD/UG ; ZD/DC ; PHI/DA ; THE/DB	.00827 (0) (1.07) (1.77) [.563; .576] <.00519>
YD/VG ; ZD/DC ; PHI/DA ; THE/DB	.0458 (0) (.0123) (.134) (1.07) (1.81) <.000147>
YD/VG ; ZD/DC ; PHI/DA ; PSI/DP	.0752 (.0347) (.556) (.714) [.552; 1.64] <.00278>
XD/WG ; ZD/DC ; PHI/DA ; THE/DB	-.00342 (0) (1.07) (2.57) [.557; .347] <-.00113>
XD/UG ; ZD/DC ; PHI/DA ; THE/DB ; PSI/DP	-.00287 (.0492) (.556) (1.07) <-.836E-4>
YD/VG ; ZD/DC ; PHI/DA ; THE/DB ; PSI/DP	-.0125 (.0113) (.556) (1.07) <-.836E-4>
XD/WG ; ZD/DC ; PHI/DA ; THE/DB ; PSI/DP	.00163 (.0901) (.556) (1.07) <.872E-4>

TABLE VI-5 CONTINUED
CH-53D TRANSFER FUNCTION FACTORS

CASE 187 80KT AFCS OFF

DENOMINATOR: (0) (.138) (.471) (1.14) (1.61) [-.325;.310][.206;1.12]<.0146>

CONTROL NUMERATORS:

PHI/DA .490 (0) (.387) (1.13) [-.335;.330][.340;1.10]<.0286>
THE/DB -.179 (0) (.0186) (.122) (.706) (1.84) [.204;1.14]<-.000681>
PSI/DP -.404 (.365) (1.31) (1.58) [-.439;.337][.0468;.505]<-.00878>

PHI/DB -.0950 (0) (.218) (-.240) (1.13) (-1.42) [.162;1.18]<-.0112>
THE/DA .0784 (0) (.0290) (-.153) (.708) [.423;1.06]<-.000280>

PHI/DA ;THE/DB -.0882 (0) (.0199) (.706) [.332;1.12]<-.00155>
PHI/DA ;PSI/DP -.205 (.0664) (.377) (1.19) [-.390;.342]<-.000712>
THE/DB ;PSI/DP .0723 (.0179) (.695) (1.84) [-.0372;.480]<.000380>

PHI/DB ;PSI/DP .0328 (.0832) (.844) (-1.37) [-.503;.114]<-.409E-4>
PHI/DP ;THE/DB -.0460 (0) (.0179) (.692) (-1.62) (1.73)<.00160>
PHI/DC ;THE/DB -.00906 (0) (.0220) (1.19) [-.0105;1.06]<-.000267>

THE/DA ;PSI/DP -.0324 (.0351) (-.548) [.997;.621]<.000241>
THE/DP ;PHI/DA -.00145 (0) (.0352) (.744) [.314;5.19]<-.00102>
THE/DC ;PHI/DA .0245 (0) (-.0151) (.476) [-.311;1.09]<.000210>

PSI/DA ;THE/DB -.00503 (.0199) (.704) (1.95) [-.318;1.61]<-.000357>
PSI/DB ;PHI/DA .0136 (.0698) (.329) (-.352) [-.101;1.50]<-.000247>
XD/DB ;PHI/DA .620 (0) (.777) [.330;1.13][.0562;2.03]<2.51>

YD/DA ;THE/DB -.157 (.0199) (.706) [.298;1.09][.0257;4.28]<-.0481>
ZD/DB ;PHI/DA 1.87 (0) (.0211) [.335;1.13][.136;2.10]<.222>
XD/DC ;PHI/DA -.0764 (0) (.498) [.307;1.08][.128;3.13]<-.436>

YD/DP ;THE/DB -.253 (.0179) (.695) (1.72) (-1.76) [.276;2.32]<.0514>
ZD/DC ;PHI/DA -4.20 (0) (.215) [-.278;.549][.362;1.11]<-.335>

PHI/DA ;THE/DB ;PSI/DP .0370 (.0175) (.0661) (.696)<.298E-4>
PHI/DC ;THE/DB ;PSI/DP .00324 (-.00269) (.0208) (.879)<-.160E-6>
THE/DC ;PHI/DA ;PSI/DP -.0103 (.00256) (.0587) (.421)<-.653E-6>

PSI/DC ;PHI/DA ;THE/DB .00107 (.0218) (.168) (-1.31)<-.512E-5>
XD/DB ;PHI/DA ;PSI/DP -.258 (.0659) (.777) [.0556;2.03]<-.0544>
YD/DA ;THE/DB ;PSI/DP .0706 (.0178) (.694) [.0242;4.09]<.0146>

ZD/DC ;PHI/DA ;THE/DB .663 (0) (.0199) [.339;1.12]<.0165>
ZD/DC ;PHI/DA ;PSI/DP 1.76 (.0721) (.271) [.293;.487]<.00813>
XD/DC ;PHI/DA ;THE/DB -.0173 (0) (-.266) [.339;1.07]<.00523>

XD/DC ;PHI/DA ;PSI/DP .0312 (.0498) (.432) [.137;3.15]<.00668>
YD/DP ;PHI/DA ;THE/DB -.0847 (.0176) (.677) (-1.97) (2.03)<.00402>
ZD/DB ;PHI/DA ;PSI/DP -.780 (.0225) (.0658) [.132;2.11]<-.00512>

ZD/DC ;PHI/DA ;THE/DB ;PSI/DP -.278 (.0178) (.0678)<-.000335>
XD/DC ;PHI/DA ;THE/DB ;PSI/DP .00735 (.0911) (-.342)<-.000229>

TABLE VI-5 CONTINUED
CH-53D TRANSFER FUNCTION FACTORS

CASE 187 80KT AFCS ON

DENOMINATOR: (0) (.0141) (-.0231) (.0454) (.561) (.714) (.829) (4.99) [.644; 1.54] <-.00276>

CONTROL NUMERATORS:

PHI/DA 25.1 (0) (-.00715) (.0455) (.560) (.714) (.828) [.632; 1.51] <-.00616>
THE/DB -8.53 (0) (.0141) (.0180) (-.0236) (.561) (.695) (1.07) (5.20) <.000111>
PSI/DP .119 (.0456) (.556) (.714) (.827) (4.72) [.0935; .293] [.643; 1.54] <.00172>

PHI/DB -4.18 (0) (.0776) (.561) (.823) (1.07) (-1.40) [-.364; .0935] <.00196>
THE/DA 4.11 (0) (.0137) (.555) (.699) (.714) [.338; .0463] <.335E-4>

PHI/DA ; THE/DB -4.52 (0) (-.00787) (.0184) (.560) (.695) (1.07) <.000272>
PHI/DA ; PSI/DP .0607 (.0461) (.0656) (.556) (.714) (.827) [.632; 1.51] <.000137>
THE/DB ; PSI/DP -.0214 (.0179) (.556) (.695) (1.07) (4.91) [.0998; .293] <-.667E-4>

PHI/DB ; PSI/DP -.00969 (.0832) (.556) (.844) (1.07) (-1.37) [-.503; .114] <.716E-5>
PHI/DP ; THE/DB .0136 (0) (-.0179) (.556) (.692) (1.07) (1.66) (-1.69) <-.000281>
PHI/DC ; THE/DB -.392 (0) (-.0122) (.0193) (.561) (.851) (1.07) <.469E-4>

THE/DA ; PSI/DP .00958 (.0351) (-.548) (.556) (.714) [.997; .621] <-.282E-4>
THE/DP ; PHI/DA .000429 (0) (.0352) (.556) (.714) (.744) [-.314; 5.19] <.000120>
THE/DC ; PHI/DA 1.26 (0) (-.00993) (.0120) (.410) (.559) (.714) <-.247E-4>

PSI/DA ; THE/DB -.0626 (-.00758) (.0184) (.556) (.695) (1.07) [.226; 4.17] <.625E-4>
PSI/DB ; PHI/DA .0209 (.0842) (.556) (1.07) (1.48) (5.09) [-.528; .0743] <.434E-4>
XD/DB ; PHI/DA 31.6 (0) (-.00730) (.560) (.777) (1.07) [.0556; 2.03] <-.440>

YD/DA ; THE/DB -8.37 (-.00761) (.0184) (.560) (.695) (1.07) [.0234; 4.16] <.00844>
ZD/DB ; PHI/DA 95.4 (0) (-.00701) (.0220) (.560) (1.07) [-.133; 2.11] <-.0390>
XD/DC ; PHI/DA -3.81 (0) (-.00752) (.560) (.652) (.714) [-.230; 2.85] <.0607>

YD/DP ; THE/DB .0749 (.0179) (.556) (.709) (1.07) (1.24) (-1.85) [.730; 2.64] <-.00901>
ZD/DC ; PHI/DA -215. (0) (-.00712) (.0420) (.560) (.714) [.555; 1.64] <.0693>

PHI/DA ; THE/DB ; PSI/DP -.0109 (.0175) (.0661) (.556) (.696) (1.07) <-.522E-5>
PHI/DC ; THE/DB ; PSI/DP -.000959 (-.00269) (.0208) (.556) (.879) (1.07) <.280E-7>
THE/DC ; PHI/DA ; PSI/DP .00305 (.00256) (.0587) (.421) (.556) (.714) <.766E-7>

PSI/DC ; PHI/DA ; THE/DB -.00298 (-.0130) (.0196) (.556) (1.07) (2.01) <.898E-6>
XD/DB ; PHI/DA ; PSI/DP .0765 (.0659) (.556) (.777) (1.07) [.0556; 2.03] <.00954>
YD/DA ; THE/DB ; PSI/DP -.0209 (.0178) (.556) (.694) (1.07) [.0242; 4.09] <-.00256>

ZD/DC ; PHI/DA ; THE/DB 33.9 (0) (-.00773) (.0186) (.560) (1.07) <-.00290>
ZD/DC ; PHI/DA ; PSI/DP -.520 (.0432) (.0648) (.556) (.714) [.555; 1.64] <-.00156>
XD/DC ; PHI/DA ; THE/DB -.899 (0) (-.00543) (-.314) (.560) (1.07) <-.000917>

XD/DC ; PHI/DA ; PSI/DP -.00924 (.0613) (.556) (.656) (.714) [-.230; 2.85] <-.00120>
YD/DP ; PHI/DA ; THE/DB .0250 (.0176) (.556) (.677) (1.07) (-1.97) (2.03) <-.000705>
ZD/DB ; PHI/DA ; PSI/DP .231 (.0225) (.0658) (.556) (1.07) [.132; 2.11] <.000898>

ZD/DC ; PHI/DA ; THE/DB ; PSI/DP .0821 (.0178) (.0678) (.556) (1.07) <.588E-4>
XD/DC ; PHI/DA ; THE/DB ; PSI/DP -.00217 (.0911) (-.342) (.556) (1.07) <.402E-4>

TABLE VI-5 CONTINUED
CH-53D TRANSFER FUNCTION FACTORS

CASE 188 100KT AFCS OFF

DENOMINATOR: (0) (.141) (.367) [-.417;.318] [.220;1.25] [.990;1.51] <.0187>

CONTROL NUMERATORS:

PHI/DA .488 (0) (.345) (1.34) [-.429;.334] [.337;1.28] <.0408>
THE/DB -.183 (0) (.0118) (.132) (.748) (1.83) [.216;1.25] <-.000609>
PSI/DP -.435 (.343) [-.502;.348] [.0103;.492] [.987;1.56] <-.0106>

PHI/DB -.114 (0) (.269) (-.289) (.975) (-1.01) [.188;1.22] <-.0130>
THE/DA .0835 (0) (.0985) (-.187) (.824) [.412;1.24] <-.00196>

PHI/DA ;THE/DB -.0899 (0) (.0248) (.738) [.328;1.28] <-.00269>
PHI/DA ;PSI/DP -.221 (.0817) (.354) (1.38) [-.486;.343] <-.00104>
THE/DB ;PSI/DP .0797 (.0222) (.725) (1.83) [-.0474;.487] <.000559>

PHI/DB ;PSI/DP .0404 (.628) [-.366;.0330] [-.931;.510] <.720E-5>
PHI/DP ;THE/DB -.0536 (0) (.0222) (.729) (-1.74) (1.94) <.00293>
PHI/DC ;THE/DB -.0143 (0) (.0287) (.917) [.161;.977] <-.000359>

THE/DA ;PSI/DP -.0371 (.0463) (-.563) (.598) (.815) <.000471>
THE/DP ;PHI/DA -.00398 (0) (.0448) (.832) [.249;3.94] <-.00231>
THE/DC ;PHI/DA .0341 (0) (.0188) (.488) [.326;1.25] <.000489>

PSI/DA ;THE/DB -.00517 (.0251) (.720) (2.26) [-.334;1.54] <-.000503>
PSI/DB ;PHI/DA .0186 (.0676) (-.265) (.409) [-.00330;1.32] <-.000238>
XD/DB ;PHI/DA .544 (0) (.922) [.321;1.29] [.0703;2.05] <3.48>

YD/DA ;THE/DB -.160 (.0253) (.747) [.293;1.23] [.0415;4.30] <-.0848>
ZD/DB ;PHI/DA 2.48 (0) (.0395) [.323;1.29] [.152;2.10] <.722>
XD/DC ;PHI/DA -.0408 (0) (.555) [.330;1.24] [.232;4.82] <-.804>

YD/DP ;THE/DB -.278 (.0223) (.747) (1.96) (-2.09) [.318;2.23] <.0944>
ZD/DC ;PHI/DA -4.54 (0) (.144) [.294;.710] [.351;1.30] <-.560>

PHI/DA ;THE/DB ;PSI/DP .0408 (.0224) (.0833) (.725) <.552E-4>
PHI/DC ;THE/DB ;PSI/DP .00548 (.654) [.977;.0236] <.200E-5>
THE/DC ;PHI/DA ;PSI/DP -.0155 (.0105) (.0767) (.465) <-.580E-5>

PSI/DC ;PHI/DA ;THE/DB .00168 (.0281) (.301) (-.346) <-.492E-5>
XD/DB ;PHI/DA ;PSI/DP -.243 (.0843) (.924) [.0696;2.05] <-.0791>
YD/DA ;THE/DB ;PSI/DP .0778 (.0211) (.727) [.0416;4.08] <.0199>

ZD/DC ;PHI/DA ;THE/DB .663 (0) (.0257) [.335;1.29] <.0283>
ZD/DC ;PHI/DA ;PSI/DP 2.05 (.0893) (.151) [.328;.696] <.0134>
XD/DC ;PHI/DA ;THE/DB -.0305 (0) (-.238) [.353;1.25] <.0113>

XD/DC ;PHI/DA ;PSI/DP .0159 (.0715) (.518) [.275;5.16] <.0157>
YD/DP ;PHI/DA ;THE/DB -.0900 (.0221) (.689) (-2.54) (2.67) <.00932>
ZD/DB ;PHI/DA ;PSI/DP -1.11 (.0400) (.0846) [.142;2.10] <-.0166>

ZD/DC ;PHI/DA ;THE/DB ;PSI/DP -.300 (.0241) (.0856) <-.000619>
XD/DC ;PHI/DA ;THE/DB ;PSI/DP .0142 (.110) (-.252) <-.000392>

TABLE VI-5 CONTINUED
CH-53D TRANSFER FUNCTION FACTORS

CASE 188 100KT AFCS ON

DENOMINATOR: (0) (.0135) (-.0179) (.0509) (.560) (.714) (1.02) (4.89) [.679;1.43]<-.00291>

CONTROL NUMERATORS:

PHI/DA 30.5 (0) (-.00703) (.0509) (.559) (.714) (1.01) [.662;1.41]<-.00871>
THE/DB -10.6 (0) (.00880) (-.0173) (.0260) (.560) (.722) (1.07) (5.15) <.935E-4>
PSI/DP .116 (.0509) (.556) (.714) (1.01) (4.66) [.108;.300][.681;1.43]<.00203>

PHI/DB -5.94 (0) (.0525) (-.897) (1.07) [-.169;.152][.000;.546]<.00205>
THE/DA 5.35 (0) (-.0110) (-.0763) (.142) (.555) (.714) (.823) <.000208>

PHI/DA ;THE/DB -5.62 (0) (-.00777) (.0226) (.559) (.724) (1.07) <.000426>
PHI/DA ;PSI/DP .0588 (.0507) (.0848) (.556) (.714) (1.00) [.664;1.41]<.000200>
THE/DB ;PSI/DP -.0213 (.0222) (.556) (.725) (1.07) (4.88) [-.113;.299]<-.884E-4>

PHI/DB ;PSI/DP -.0108 (.556) (.628) (1.07) [-.366;.0330][-.931;.510]<-.114E-5>
PHI/DP ;THE/DB .0143 (0) (.0222) (.556) (.729) (1.07) (-1.76) (1.92) <-.000464>
PHI/DC ;THE/DB -.750 (0) (-.00897) (.0232) (.562) (.607) (1.07) <.567E-4>

THE/DA ;PSI/DP .00988 (.0463) (.556) (-.563) (.598) (.714) (.815) <-.498E-4>
THE/DP ;PHI/DA .00106 (0) (.0448) (.556) (.714) (.832) [-.249;3.94] <.000244>
THE/DC ;PHI/DA 2.14 (0) (-.00826) (.0161) (.454) (.558) (.714) <-.517E-4>

PSI/DA ;THE/DB -.0620 (-.00758) (.0226) (.556) (.726) (1.07) [.0770;4.16] <.795E-4>
PSI/DB ;PHI/DA .0301 (.0290) (.556) (1.07) (1.18) (7.68) [-.0496;.0894] <.376E-4>
XD/DB ;PHI/DA 33.6 (0) (-.00711) (.559) (.924) (1.07) [.0693;2.05] <-.551>

YD/DA ;THE/DB -10.7 (-.00760) (.0227) (.559) (.730) (1.07) [.0401;4.09] <.0134>
ZD/DB ;PHI/DA 154. (0) (-.00701) (.0401) (.559) (1.07) [-.144;2.10] <-.114>
XD/DC ;PHI/DA -2.21 (0) (-.00712) (.559) (.714) (.828) [-.537;4.46] <.104>

YD/DP ;THE/DB .0742 (.0223) (.556) (1.07) (-2.23) [.994;.904] [-.769;2.89] <-.0149>
ZD/DC ;PHI/DA -283. (0) (-.00702) (.0482) (.559) (.714) [.533;1.66] <.106>

PHI/DA ;THE/DB ;PSI/DP -.0109 (.0224) (.0833) (.556) (.725) (1.07) <-.873E-5>
PHI/DC ;THE/DB ;PSI/DP -.00146 (.556) (.654) (1.07) [.977;.0236] <-.315E-6>
THE/DC ;PHI/DA ;PSI/DP .00414 (.0105) (.0767) (.465) (.556) (.714) <.614E-6>

PSI/DC ;PHI/DA ;THE/DB -.00228 (-.00973) (.0229) (.556) (1.07) (2.58) <.778E-6>
XD/DB ;PHI/DA ;PSI/DP .0648 (.0843) (.556) (.924) (1.07) [.0696;2.05] <.0125>
YD/DA ;THE/DB ;PSI/DP -.0207 (.0211) (.556) (.727) (1.07) [.0416;4.08] <-.00314>

ZD/DC ;PHI/DA ;THE/DB 41.3 (0) (-.00768) (.0237) (.559) (1.07) <-.00448>
ZD/DC ;PHI/DA ;PSI/DP -.546 (.0481) (.0844) (.556) (.714) [.534;1.66] <-.00243>
XD/DC ;PHI/DA ;THE/DB -1.96 (0) (-.00687) (-.224) (.559) (1.07) <-.00179>

XD/DC ;PHI/DA ;PSI/DP -.00425 (.0821) (.556) (.714) (.830) [-.538;4.47] <-.00230>
YD/DP ;PHI/DA ;THE/DB .0240 (.0221) (.556) (.689) (1.07) (-2.54) (2.67) <-.00147>
ZD/DB ;PHI/DA ;PSI/DP .297 (.0400) (.0846) (.556) (1.07) [.142;2.10] <.00263>

ZD/DC ;PHI/DA ;THE/DB ;PSI/DP .0799 (.0241) (.0856) (.556) (1.07) <.978E-4>
XD/DC ;PHI/DA ;THE/DB ;PSI/DP -.00378 (.110) (-.252) (.556) (1.07) <.620E-4>

TABLE VI-5 CONTINUED
CH-53D TRANSFER FUNCTION FACTORS

CASE 189 I20KT AFCS OFF

DENOMINATOR: (0) (.172) (.254) [-.593;.336] [.231;1.38] .976;1.67<.0263>

CONTROL NUMERATORS:

PHI/DA .489 (0) (.299) (1.58) [-.585;.342] [.338;1.45] <.0571>
THE/DB -.192 (0) (.0146) (.147) (.720) (1.85) [.227;1.36] <-.00101>
PSI/DP -.466 (.318) [-.615;.372] [-.0475;.486] [.976;1.70] <-.0141>

PHI/DB -.140 (0) [.829;.579] [-.685;.583] [.235;1.11] <-.0198>
THE/DA .0923 (0) (.106) (-.161) (-.382) [.407;1.43] <-.00283>

PHI/DA ;THE/DB -.0944 (0) (.0300) (.732) [-.329;1.45] <-.00434>
PHI/DA ;PSI/DP -.237 (.0977) (.327) (1.61) [-.626;.352] <-.00152>
THE/DB ;PSI/DP .0899 (.0272) (.724) (1.87) [-.0872;.507] <.000851>

PHI/DB ;PSI/DP .0541 (.457) [-.121;.0258] [-.346;.855] <.120E-4>
PHI/DP ;THE/DB -.0636 (0) (.0272) (.740) (-1.89) (2.20) <.00534>
PHI/DC ;THE/DB -.0183 (0) (.0344) (.588) [.337;1.14] <-.000477>

THE/DA ;PSI/DP -.0441 (.0523) (-.523) (.654) (.851) <.000672>
THE/DP ;PHI/DA -.00532 (0) (.0503) (.912) [.244;4.02] <-.00394>
THE/DC ;PHI/DA .0455 (0) (.0260) (.468) [.333;1.42] <.00112>

PSI/DA ;THE/DB -.00538 (.0305) (.724) (2.50) [-.392;1.51] <-.000674>
PSI/DB ;PHI/DA .0212 (.0787) (-.278) (.565) [-.0382;1.13] <-.000332>
XD/DB ;PHI/DA .478 (0) (1.12) [.316;1.44] [.0720;2.03] <.4.59>

YD/DA ;THE/DB -.171 (.0308) (.744) [-.295;1.36] [.0536;4.33] <-.137>
ZD/DB ;PHI/DA 3.06 (0) (.0528) [.312;1.45] [.174;2.12] <.1.52>
XD/DC ;PHI/DA .0308 (0) (.589) (4.70) (-7.71) [.345;1.42] <-.1.32>

YD/DP ;THE/DB -.310 (.0273) (.771) (2.31) (-2.48) [.339;2.15] <.172>
ZD/DC ;PHI/DA -4.84 (0) (.122) [-.286;.856] [.347;1.49] <-.968>

PHI/DA ;THE/DB ;PSI/DP .0461 (.0274) (-.101) (.726) <.923E-4>
PHI/DC ;THE/DB ;PSI/DP .00786 (.0290) (.0415) (.557) <.527E-5>
THE/DC ;PHI/DA ;PSI/DP -.0223 (.0204) (.0943) (.472) <-.203E-4>

PSI/DC ;PHI/DA ;THE/DB .00157 (.0349) (-.141) (.512) <-.396E-5>
XD/DB ;PHI/DA ;PSI/DP -.230 (.102) (1.12) [.0694;2.02] <-.107>
YD/DA ;THE/DB ;PSI/DP .0889 (.0258) (.727) [.0529;4.08] <.0278>

ZD/DC ;PHI/DA ;THE/DB .651 (0) (.0314) [.333;1.46] <.0436>
ZD/DC ;PHI/DA ;PSI/DP 2.34 (.112) (.118) [.312;.875] <.0239>
XD/DC ;PHI/DA ;THE/DB -.0505 (0) (-.0954) [.345;1.44] <.00996>

XD/DC ;PHI/DA ;PSI/DP -.0173 (.0918) (.576) (4.35) (-7.24) <.0289>
YD/DP ;PHI/DA ;THE/DB -.0962 (.0270) (.680) (-3.18) (3.32) <.0187>
ZD/DB ;PHI/DA ;PSI/DP -1.48 (.0533) (-.103) [.156;2.11] <-.0360>

ZD/DC ;PHI/DA ;THE/DB ;PSI/DP -.317 (.0297) (.103) <-.000971>
XD/DC ;PHI/DA ;THE/DB ;PSI/DP .0249 (-.102) (-.128) <-.000326>

TABLE VI-5 CONTINUED
CH-53D TRANSFER FUNCTION FACTORS

CASE 189 120KT AFCS ON

DENOMINATOR: . (0) (-.0155) (.0164) (.0582) (.559) (.714) (1.44) (4.83) [.701;1.23]<-.00425>

CONTROL NUMERATORS:

PHI/DA 36.2 (0) (-.00686) (.0585) (.558) (.714) (1.35) [.680;1.24]<-.0121>
 THE/DB -13.0 (0) (.0122) (-.0149) (.0299) (.559) (.718) (1.07) (5.18) <.000157>
 PSI/DP .114 (.0584) (.556) (.714) (1.42) (4.59) [.101;-.317][.706;1.23]<.00265>

PHI/DB -8.85 (0) (.0469) (.211) (-.213) (.557) (1.07) [-.203;.509]<.00287>
 THE/DA 6.95 (0) (-.0104) (-.0737) (.148) (.555) (.714) (.881) <.000275>

PHI/DA ;THE/DB -7.02 (0) (-.00759) (.0275) (.558) (.723) (1.07) <.000631>
 PHI/DA ;PSI/DP .0582 (.0581) (.103) (.556) (.714) (1.35) [.683;1.24]<.000286>
 THE/DB ;PSI/DP -0.0220 (.0272) (.556) (.725) (1.07) (4.89) [.103;-.313]<-.000124>

PHI/DB ;PSI/DP -0.0133 (.457) (.556) (1.07) [.121;.0258][-.346;.855]<-.174E-5>
 PHI/DP ;THE/DB .0156 (0) (.0272) (.556) (.740) (1.07) (-1.85) (2.25) <-.000775>
 PHI/DC ;THE/DB -1.19 (0) (-.00694) (.0277) (.510) (.555) (1.07) <.693E-4>

THE/DA ;PSI/DP .0108 (.0523) (-.523) (.556) (.654) (.714) (.851) <-.654E-4>
 THE/DP ;PHI/DA .00130 (0) (.0503) (.556) (.714) (.912) [.244;4.02]<.000383>
 THE/DC ;PHI/DA 3.40 (0) (-.00740) (.0236) (.461) (.558) (.714) <-.000109>

PSI/DA ;THE/DB -0.0647 (-.00742) (.0275) (.556) (.726) (1.07) [-.249;4.16]<.980E-4>
 PSI/DB ;PHI/DA .381 (.0295) (.556) (1.05) (1.07) [-.00515;.0831]<.483E-4>
 XD/DB ;PHI/DA 35.1 (0) (-.00697) (.558) (1.07) (1.12) [.0685;2.02]<-.668>

YD/DA ;THE/DB -13.9 (-.00743) (.0275) (.559) (.733) (1.07) [.0509;4.00]<.0199>
 ZD/DB ;PHI/DA 276. (0) (-.00687) (.0535) (.558) (1.07) [.158;2.12]<-.222>
 XD/DC ;PHI/DA 27.7 (0) (-.00693) (.558) (.714) (.970) (-1.93) <.143>

YD/DP ;THE/DB .0761 (.0273) (.556) (1.07) (-2.66) [.967;.895][.797;3.10]<-.0251>
 ZD/DC ;PHI/DA -358. (0) (-.00686) (.0568) (.558) (.714) [.512;1.69]<.160>

PHI/DA ;THE/DB ;PSI/DP -0.0113 (.0274) (.101) (.556) (.726) (1.07) <-.134E-4>
 PHI/DC ;THE/DB ;PSI/DP -0.00193 (.0290) (.0415) (.556) (.557) (1.07) <-.766E-6>
 THE/DC ;PHI/DA ;PSI/DP .00546 (.0204) (-.0943) (.472) (.556) (.714) <.197E-5>

PSI/DC ;PHI/DA ;THE/DB -0.00216 (-.00626) (.0275) (.556) (1.07) (2.61) <.575E-6>
 XD/DB ;PHI/DA ;PSI/DP .0563 (.102) (.556) (1.07) (1.12) [.0694;2.02]<.0156>
 YD/DA ;THE/DB ;PSI/DP -0.0218 (.0258) (.556) (.727) (1.07) [.0529;4.08]<-.00404>

ZD/DC ;PHI/DA ;THE/DB 48.2 (0) (-.00766) (.0288) (.558) (1.07) <-.00634>
 ZD/DC ;PHI/DA ;PSI/DP -0.575 (-.0566) (.103) (.556) (.714) [.513;1.69]<-.00378>
 XD/DC ;PHI/DA ;THE/DB -3.80 (0) (-.00862) (-.0742) (.558) (1.07) <-.00145>

XD/DC ;PHI/DA ;PSI/DP .0446 (.0999) (.556) (.714) (.971) (-1.92) <-.00330>
 YD/DP ;PHI/DA ;THE/DB .0236 (.0270) (.556) (.680) (1.07) (-3.18) (3.32) <-.00272>
 ZD/DB ;PHI/DA ;PSI/DP .362 (.0533) (.103) (.556) (1.07) [.156;2.11]<.00524>

ZD/DC ;PHI/DA ;THE/DB ;PSI/DP .0776 (.0297) (.103) (.556) (1.07) <.000141>
 XD/DC ;PHI/DA ;THE/DB ;PSI/DP -0.00611 (-.102) (.128) (.556) (1.07) <.474E-4>

TABLE VI-5 CONTINUED
CH-53D TRANSFER FUNCTION FACTORS

CASE 190 140KT AFCS OFF

DENOMINATOR: (0) [.953; .188] [-.819; .350] [.238; 1.54] [.963; 1.86] < .0352 >

CONTROL NUMERATORS:

PHI/DA	.492	(0)	(.268)	(1.81)	[-.759; .345]	[.340; 1.65]	< .0776 >
THE/DB	-.210	(0)	(.0210)	(.166)	(.644)	(1.93)	[.244; 1.48] < -.00200 >
PSI/DP	-.502	(.309)	[-.745; .402]	[-.105; .451]	[.965; 1.86]	< -.0177 >	
PHI/DB	-.178	(0)	[.194; .188]	[-.339; 1.34]	[.602; 1.46]	< -.0240 >	
THE/DA	.106	(0)	(.113)	(-.131)	(.931)	[.402; 1.63]	< -.00390 >
PHI/DA ; THE/DB	-.105	(0)	(.0352)	(.720)	[.336; 1.63]	< -.00705 >	
PHI/DA ; PSI/DP	-.258	(.112)	(.314)	(1.83)	[-.767; .355]	< -.00208 >	
THE/DB ; PSI/DP	.106	(.0336)	(.732)	(1.96)	[-.155; .520]	< .00138 >	
PHI/DB ; PSI/DP	.0762	(-.0408)	(.0465)	(.347)	[-.125; 1.30]	< -.842E-4 >	
PHI/DP ; THE/DB	-.0795	(0)	(.0336)	(.769)	(-2.01)	(2.44)	< .0101 >
PHI/DC ; THE/DB	-.0237	(0)	(.0286)	(.235)	[.434; 1.46]	< -.000336 >	
THE/DA ; PSI/DP	-.0550	(.0522)	(-.457)	(.766)	(.821)	< .000825 >	
THE/DP ; PHI/DA	-.00816	(0)	(.0493)	(1.01)	[.238; 3.69]	< -.00556 >	
THE/DC ; PHI/DA	.0607	(0)	(.0382)	(.488)	[.341; 1.62]	< .00298 >	
PSI/DA ; THE/DB	-.00565	(.0356)	(.730)	(2.74)	[-.524; 1.52]	< -.000936 >	
PSI/DB ; PHI/DA	.0230	(.0854)	(-.437)	(1.04)	[-.300; .698]	< -.000436 >	
XD/DB ; PHI/DA	.485	(0)	(1.47)	[.317; 1.60]	[.0396; 1.86]	< 6.31 >	
YD/DA ; THE/DB	-.197	(.0360)	(.732)	[.301; 1.50]	[.0891; 4.36]	< -.221 >	
ZD/DB ; PHI/DA	3.54	(0)	(.0617)	[.302; 1.61]	[.195; 2.24]	< 2.86 >	
XD/DC ; PHI/DA	.120	(0)	(.718)	(2.89)	(-3.57)	[.362; 1.64]	< -2.39 >
YD/DP ; THE/DB	-.365	(.0337)	(.825)	(2.69)	(-2.87)	[.372; 2.04]	< .326 >
ZD/DC ; PHI/DA	-4.98	(0)	(.106)	[.264; 1.08]	[.341; 1.72]	< -1.82 >	
PHI/DA ; THE/DB ; PSI/DP	.0551	(.0334)	(.118)	(.731)	< .000158 >		
PHI/DC ; THE/DB ; PSI/DP	.0114	(.0342)	(.0598)	(.464)	< .108E-4 >		
THE/DC ; PHI/DA ; PSI/DP	-.0321	(.0366)	(.112)	(.521)	< -.686E-4 >		
PSI/DC ; PHI/DA ; THE/DB	.00146	(1.11)	[.813; .0374]	< .226E-5 >			
XD/DB ; PHI/DA ; PSI/DP	-.255	(.119)	(1.47)	[.0294; 1.83]	< -.149 >		
YD/DA ; THE/DB ; PSI/DP	.110	(.0319)	(.730)	[.0838; 4.08]	< .0424 >		
ZD/DC ; PHI/DA ; THE/DB	.621	(0)	(.0331)	[.333; 1.65]	< .0560 >		
ZD/DC ; PHI/DA ; PSI/DP	2.59	(.109)	(.122)	[.277; 1.16]	< .0462 >		
XD/DC ; PHI/DA ; THE/DB	-.0854	(0)	(.111)	[.341; 1.64]	< -.0254 >		
XD/DC ; PHI/DA ; PSI/DP	-.0618	(.112)	(.748)	(2.96)	(-3.69)	< .0566 >	
YD/DP ; PHI/DA ; THE/DB	-.107	(.0330)	(.676)	(-3.89)	(4.01)	< .0374 >	
ZD/DB ; PHI/DA ; PSI/DP	-1.84	(.0627)	(.121)	[.168; 2.23]	< -.0692 >		
ZD/DC ; PHI/DA ; THE/DB ; PSI/DP	-.325	(.0312)	(.121)	< -.00123 >			
XD/DC ; PHI/DA ; THE/DB ; PSI/DP	.0450	(.0767)	(.176)	< .000609 >			

TABLE VI-5 CONTINUED
CH-53D TRANSFER FUNCTION FACTORS

CASE 190 140KT AFCS ON

DENOMINATOR: (0) (-.0134) (.0217) (.0616) (.559) (.714) (2.03) (4.74) [.678; 1.10] <-.00634>

CONTROL NUMERATORS:

PHI/DA	41.6	(0)	(-.00669)	(.0648)	(.558)	(.714)	(1.78)	[.667; 1.13]	<-.0164>
THE/DB	-15.9	(0)	(-.0127)	(.559)	(.715)	(1.07)	(5.31)	[.984; .0253]	<.000293>
PSI/DP	.112	(.0643)	(.556)	(.714)	(2.00)	(4.50)	[.0743; .335]	[.689; 1.10]	<.00344>
PHI/DB	-13.3	(0)	(.0155)	(-.131)	(.168)	(.557)	(1.07)	[-.0308; 1.08]	<.00315>
THE/DA	9.05	(0)	(-.00942)	(-.0690)	(.157)	(.554)	(.714)	(.934)	<.000341>
PHI/DA ; THE/DB	-8.88	(0)	(-.00727)	(.0332)	(.558)	(.728)	(1.07)	<.000929>	
PHI/DA ; PSI/DP	.0573	(.0639)	(.122)	(.556)	(.714)	(1.79)	[.668; 1.12]	<.000399>	
THE/DB ; PSI/DP	-.0236	(.0336)	(.556)	(.731)	(1.07)	(4.97)	[.0693; .327]	<-.000182>	
PHI/DB ; PSI/DP	-.0169	(-.0408)	(.0465)	(.347)	(.556)	(1.07)	[-.125; 1.30]	<.111E-4>	
PHI/DP ; THE/DB	.0177	(0)	(.0336)	(.556)	(.768)	(1.07)	(-1.91)	(2.56)	<-.00132>
PHI/DC ; THE/DB	-1.82	(0)	(-.00293)	(.0341)	(.411)	(.557)	(1.07)	<.444E-4>	
THE/DA ; PSI/DP	.0122	(.0522)	(-.457)	(.556)	(.714)	(.766)	(.821)	<-.728E-4>	
THE/DP ; PHI/DA	.00182	(0)	(.0493)	(.556)	(.714)	(1.01)	[.238; 3.69]	<.000490>	
THE/DC ; PHI/DA	5.18	(0)	(-.00667)	(.0372)	(.513)	(.557)	(.714)	<-.000263>	
PSI/DA ; THE/DB	-.0716	(-.00710)	(.0332)	(.556)	(.731)	(1.07)	[-.745; 4.11]	<.000123>	
PSI/DB ; PHI/DA	.625	(.0247)	(.557)	(.938)	(1.07)	[.0702; .0818]	<.575E-4>		
XD/DB ; PHI/DA	41.1	(0)	(-.00689)	(.558)	(1.07)	(1.47)	[.0260; 1.83]	<-.831>	
YD/DA ; THE/DB	-18.6	(-.00711)	(.0333)	(.558)	(.742)	(1.07)	[-.0814; 3.87]	<.0292>	
ZD/DB ; PHI/DA	298.	(0)	(-.00671)	(.0634)	(.558)	(1.07)	[.170; 2.23]	<-.376>	
XD/DC ; PHI/DA	10.0	(0)	(-.00668)	(.558)	(.714)	(-.930)	(1.24)	(5.70)	<.176>
YD/DP ; THE/DB	.0812	(.0337)	(.556)	(1.07)	(-3.08)	[.924; .875]	[.827; 3.35]	<-.0430>	
ZD/DC ; PHI/DA	-419.	(0)	(-.00669)	(.0643)	(.558)	(.714)	[.476; 1.82]	<.237>	
PHI/DA ; THE/DB ; PSI/DP	-.0122	(.0334)	(.118)	(.556)	(.731)	(1.07)	<-.209E-4>		
PHI/DC ; THE/DB ; PSI/DP	-.00253	(.0342)	(.0598)	(.464)	(.556)	(1.07)	<-.142E-5>		
THE/DC ; PHI/DA ; PSI/DP	.00714	(.0366)	(.112)	(.521)	(.556)	(.714)	<.605E-5>		
PSI/DC ; PHI/DA ; THE/DB	-.00307	(.00263)	(.0340)	(.556)	(1.07)	(1.83)	<-.298E-6>		
XD/DB ; PHI/DA ; PSI/DP	.0567	(.119)	(.556)	(1.07)	(1.47)	[.0294; 1.83]	<.0197>		
YD/DA ; THE/DB ; PSI/DP	-.0244	(.0319)	(.556)	(.730)	(1.07)	[.0838; 4.08]	<-.00559>		
ZD/DC ; PHI/DA ; THE/DB	52.4	(0)	(-.00780)	(.0303)	(.558)	(1.07)	<-.00737>		
ZD/DC ; PHI/DA ; PSI/DP	-.576	(.0635)	(.121)	(.556)	(.714)	[.477; 1.81]	<-.00575>		
XD/DC ; PHI/DA ; THE/DB	-7.25	(0)	(-.00592)	(.131)	(.558)	(1.07)	<.00335>		
XD/DC ; PHI/DA ; PSI/DP	.0137	(.116)	(.556)	(.714)	(-.934)	(1.24)	(5.72)	<-.00417>	
YD/DP ; PHI/DA ; THE/DB	.0239	(.0330)	(.556)	[.676]	(1.07)	(-3.89)	(4.01)	<-.00493>	
ZD/DB ; PHI/DA ; PSI/DP	.409	(.0627)	(.121)	(.556)	(1.07)	[.168; 2.23]	<.00912>		
ZD/DC ; PHI/DA ; THE/DB ; PSI/DP	.0723	(.0312)	(.121)	(.556)	(1.07)	<.000162>			
XD/DC ; PHI/DA ; THE/DB ; PSI/DP	-.0100	(.0767)	(.176)	(.556)	(1.07)	<-.803E-4>			

TABLE VI-5 CONTINUED
CH-53D TRANSFER FUNCTION FACTORS

CASE 191 150KT AFCS ON

DENOMINATOR: (0) (-.0121) (.0222) (.0689) (.559) (.714) (2.45) (4.61) [-.680;1.06] <-.00749>

CONTROL NUMERATORS:

PHI/DA 44.9 (0) (-.00628) (.0718) (.557) (.714) (2.06) [-.673;1.09] <-.0197>
 THE/DB -18.4 (0) (-.0116) (.0229) (.0324) (.559) (.699) (1.07) (5.44) <.000358>
 PSI/DP .112 (.0711) (.556) (.714) (2.39) (4.41) [-.0527;.343] [-.697;1.05] <.00426>

PHI/DB -17.1 (0) (.0207) (-.112) (.158) (.557) (1.07) [-.000136;1.17] <.00508>
 THE/DA -1.21 (0) (-.00961) (-.0662) (-.178) (.552) (.714) (.945) (-8.04) <.000411>

PHI/DA ;THE/DB -10.5 (0) (-.00714) (.0383) (.558) (.714) (1.07) <.00122>
 PHI/DA ;PSI/DP .0575 (.0704) (.133) (.556) (.714) (2.08) [-.674;1.07] <.000511>
 THE/DB ;PSI/DP -0.258 (.0387) (.556) (.723) (1.07) (5.06) [-.0466;.330] <-.000236>

PHI/DB ;PSI/DP -0.202 (-.0306) (.0528) (.348) (.556) (1.07) [-.0945;1.39] <.131E-4>
 PHI/DP ;THE/DB .0200 (0) (.0387) (.556) (.771) (1.07) (-1.93) (2.69) <-.00183>
 PHI/DC ;THE/DB -2.34 (0) (-.00273) (.0390) (.397) (.557) (1.07) <.590E-4>

THE/DA ;PSI/DP -0.00157 (.0570) (-.527) (.556) (.714) (-7.80) [-.989;.890] <-.000116>
 THE/DP ;PHI/DA .00342 (0) (.0545) (.556) (.714) (1.00) [-.220;3.39] <.000856>
 THE/DC ;PHI/DA 6.10 (0) (-.00630) (.0427) (.497) (.557) (.714) <-.000325>

PSI/DA ;THE/DB -0.0801 (-.00700) (.0382) (.556) (.716) (1.07) (-2.87) (-5.82) <.000152>
 PSI/DB ;PHI/DA .847 (.0327) (.556) (.903) (1.07) [-.0616;.0762] <.863E-4>
 XD/DB ;PHI/DA 45.1 (0) (-.00661) (.557) (1.07) (1.57) [-.0106;1.81] <-.919>

YD/DA ;THE/DB -22.5 (-.00701) (.0384) (.558) (.729) (1.07) [-.0899;3.85] <.0388>
 ZD/DB ;PHI/DA 332. (0) (-.00636) (.0714) (.557) (1.07) [-.184;2.35] <-.497>
 XD/DC ;PHI/DA 12.5 (0) (-.00629) (.558) (.714) (-.777) (1.25) (5.99) <.182>

YD/DP ;THE/DB .0849 (.0389) (.556) (1.07) (-3.41) [-.888;.832] [-.830;3.59] <-.0598>
 ZD/DC ;PHI/DA -449. (0) (-.00628) (.0716) (.557) (.714) [-.496;1.90] <.290>

PHI/DA ;THE/DB ;PSI/DP -0.0136 (.0384) (.126) (.556) (.718) (1.07) <-.280E-4>
 PHI/DC ;THE/DB ;PSI/DP -0.00303 (.0393) (.0671) (.454) (.556) (1.07) <-.215E-5>
 THE/DC ;PHI/DA ;PSI/DP .00785 (.0418) (.118) (.509) (.556) (.714) <.781E-5>

PSI/DC ;PHI/DA ;THE/DB -0.00332 (0) (.0387) (.556) (1.07) (1.88) <-.000144>
 XD/DB ;PHI/DA ;PSI/DP .0581 (.129) (.556) (1.07) (1.57) [-.00533;1.81] <.0228>
 YD/DA ;THE/DB ;PSI/DP -0.0270 (.0364) (.556) (.711) (1.07) [-.0917;4.13] <-.00705>

ZD/DC ;PHI/DA ;THE/DB 60.2 (0) (-.00790) (.0347) (.557) (1.07) <-.00982>
 ZD/DC ;PHI/DA ;PSI/DP -0.575 (.0705) (.131) (.556) (.714) [-.498;1.89] <-.00752>
 XD/DC ;PHI/DA ;THE/DB -9.06 (0) (-.00545) (.132) (.557) (1.07) <.00389>

XD/DC ;PHI/DA ;PSI/DP .0159 (.123) (.556) (.714) (-.784) (1.23) (6.03) <-.00454>
 YD/DP ;PHI/DA ;THE/DB .0237 (.0379) (.556) (.644) (1.07) (-4.51) (4.58) <-.00708>
 ZD/DB ;PHI/DA ;PSI/DP .424 (.0705) (.131) (.556) (1.07) [-.181;2.34] <.0127>

ZD/DC ;PHI/DA ;THE/DB ;PSI/DP .0776 (.0360) (.131) (.556) (1.07) <.000217>
 XD/DC ;PHI/DA ;THE/DB ;PSI/DP -0.0117 (.0765) (.188) (.556) (1.07) <-.997E-4>

TABLE VI-5 CONCLUDED
CH-53D TRANSFER FUNCTION FACTORS

CASE 19I 150KT AFCS OFF

DENOMINATOR: (0) [.927; .191] [-.898; .354] [.242; 1.58] [.961; 1.94] <.0430>

CONTROL NUMERATORS:

PHI/DA .498 (0) (.257) (1.93) [-.840; .345] [.354; 1.71] <.0861>
 THE/DB -.228 (0) (.0204) (.176) (.642) (2.00) [.236; 1.54] <-.00251>
 PSI/DP -.538 (.317) [-.826; .428] [-.108; .431] [.965; 1.95] <-.0221>

PHI/DB -.201 (0) [.156; .220] [.547; 1.38] [-.186; 1.50] <-.0415>
 THE/DA -.0122 (0) (.115) (-.158) (.941) (-8.67) [.442; 1.67] <-.00507>

PHI/DA ; THE/DB -.116 (0) (.0416) (.711) [.345; 1.70] <-.00992>
 PHI/DA ; PSI/DP -.277 (.117) (.324) (1.97) [-.862; .361] <-.00270>
 THE/DB ; PSI/DP .124 (-.0387) (.730) (2.03) [-.191; .519] <.00192>

PHI/DB ; PSI/DP .0972 (-.0306) (.0528) (.348) [-.0945; 1.39] <-.000106>
 PHI/DP ; THE/DB -.0963 (0) (.0387) (.773) (-2.05) (2.53) <.0150>
 PHI/DC ; THE/DB -.0295 (0) (.0327) (.242) [.452; 1.43] <-.000478>

THE/DA ; PSI/DP .00757 (.0570) (-.527) (-7.80) [.989; .890] <.00140>
 THE/DP ; PHI/DA -.0164 (0) (.0545) (1.00) [.220; 3.39] <-.0104>
 THE/DC ; PHI/DA .0667 (0) (.0445) (.472) [.353; 1.68] <.00394>

PSI/DA ; THE/DB -.00498 (.0424) (.715) (2.75) [-.756; 1.72] <-.00123>
 PSI/DB ; PHI/DA .0187 (.0965) (-.334) (.832) [-.342; 1.18] <-.000700>
 XD/DB ; PHI/DA .499 (0) (1.59) [.319; 1.68] [.00705; 1.82] <7.47>

YD/DA ; THE/DB -.222 (.0429) (.726) [.292; 1.53] [.108; 4.37] <-.312>
 ZD/DB ; PHI/DA 3.69 (0) (.0687) [.311; 1.70] [.204; 2.34] <4.04>
 XD/DC ; PHI/DA .142 (0) (.713) (2.89) (-3.20) [.380; 1.70] <-2.69>

YD/DP ; THE/DB -.409 (.0389) (.850) (2.89) (-3.14) [.397; 1.99] <.485>
 ZD/DC ; PHI/DA -5.00 (0) (.111) [-.274; 1.13] [.355; 1.80] <-2.30>

PHI/DA ; THE/DB ; PSI/DP .0652 (.0384) (.126) (.718) <.000227>
 PHI/DC ; THE/DB ; PSI/DP .0146 (.0393) (.0671) (.454) <.174E-4>
 THE/DC ; PHI/DA ; PSI/DP -.0378 (.0418) (.118) (-.509) <-.946E-4>

PSI/DC ; PHI/DA ; THE/DB .00237 (.832) [.847; .0467] <.431E-5>
 XD/DB ; PHI/DA ; PSI/DP -.279 (.129) (1.57) [-.00533; 1.81] <-.185>
 YD/DA ; THE/DB ; PSI/DP .130 (.0364) (.711) [.0917; 4.13] <.0572>

ZD/DC ; PHI/DA ; THE/DB .673 (0) (.0396) [.343; 1.73] <.0798>
 ZD/DC ; PHI/DA ; PSI/DP 2.76 (.115) (.136) [.295; 1.22] <.0641>
 XD/DC ; PHI/DA ; THE/DB -.0999 (0) (.108) [.354; 1.71] <-.0316>

XD/DC ; PHI/DA ; PSI/DP -.0763 (.118) (.732) (3.04) (-3.35) <.0674>
 YD/DP ; PHI/DA ; THE/DB -.114 (.0379) (.644) (-4.51) (4.58) <.0574>
 ZD/DB ; PHI/DA ; PSI/DP -2.04 (.0705) (.131) [-.181; 2.34] <-.103>

ZD/DC ; PHI/DA ; THE/DB ; PSI/DP -.373 (.0360) (.131) <-.00176>
 XD/DC ; PHI/DA ; THE/DB ; PSI/DP .0561 (.0765) (.188) <.000809>

REFERENCES

1. Heffley, Robert K., A Compilation and Analysis of Helicopter Handling Qualities Data, Volume Two: Data Analysis, Systems Technology, Inc. TR 1087-2, March 1978.
2. McRuer, Duane, Irving Ashkenas, and Dunstan Graham, Aircraft Dynamics and Automatic Control, Princeton University Press: Princeton, New Jersey, 1973.
3. Siegel, Eleanor, Stability and Control Data Summary for Single Rotor Helicopter, Hughes OH-6A, Hughes Report No. 369-V-8010, April 1975.
4. McLaughlin, J. J., Stability and Control Data for the BO-105 Helicopter, Boeing Vertol Report No. D212-10035-1, May 1975.
5. Davis, John M., Stability and Control Data Summaries for the AH-1G and UH-1H Helicopters, Bell Helicopter Co. Report No. 699-099-012, January 1976.
6. CH-53D Data Submitted to NASA by Sikorsky Aircraft via Transmittal Letter SEL 9345 of 17 October 1975.
7. Taylor, John W. R. (ed.), Jane's All the World's Aircraft 1973-74, Sixty-Fourth Year of Issue, McGraw-Hill Book Company: New York, N.Y., 1973.
8. Nagata, John I., and John J. Shapley, Jr., Engineering Flight Test of the OH-6A Helicopter (Cayuse), Phase D Final Report, USAASTA Report, April 1969.
9. Staley, James A., Validation of Rotorcraft Flight Simulation Program Through Correlation with Flight Data for Soft-in-Plane Hingeless Rotors, USAAMRDL-TR-75-50, January 1976.
10. Finnestead, Rodger, L., et al, Engineering Flight Test, AH-1G Helicopter (Hueycobra), USAASTA Project No. 66-06, December 1970.
11. Dominick, Floyd and Emery E. Nelson, Engineering Flight Test, YUH-1H Helicopter, USAASTA Project No. 66-04, November 1970.
12. Briczinsky, S. J., Validation of the Rotorcraft Flight Simulation Program (C-81) for Articulated Rotor Helicopters Through Correlation with Flight Data, USAAMRDL-TR-76-4, May 1976.
13. NATOPS Flight Manual, Navy Model CH-53A/D Helicopters, NAVAIR 01-230HMA-1, 15 March 1971.

APPENDIX A
PROCEDURE FOR FORMULATING EQUATIONS OF MOTION

The following pages illustrate the procedure used in formulating the equations of motion used in the calculation of the transfer function data.

In expressing equations of motion the objective was to input body-fixed FRL stability and control derivatives and to compute transfer functions in terms of earth-fixed earth-frame velocities and body-frame Euler angles. In doing so, it was important to minimize the number of equations for reasons of computational economy.

A means of accomplishing this is to develop a general matrix algebra scheme for directly expressing the six equations of motion in terms of the six desired states. This avoids use of auxiliary equations but requires handling second-order linear differential equations.

In order to describe the algebraic manipulations, matrix equations are expressed in a simple form involving the following features:

1. A reference frame transformation of velocity components from earth to body (FRL) is expressed as

$$\begin{matrix} V \\ B \end{matrix} = \begin{matrix} T \\ B/E \end{matrix} \begin{matrix} V \\ E \end{matrix}$$

where V_B is the set of body velocities

V_E is the set of earth velocities

and $T_{B/E}$ is the transformation matrix between the two reference frames and is a function of the body Euler angles, η .

2. Perturbation quantities are denoted by the differential operator, Δ , thus:

$$\Delta V_B = \Delta T_{B/E} V_E(0) + T_{B/E}(0) \Delta V_E$$

where ΔV_B and ΔV_E are perturbation velocities in the respective reference frames. $\Delta T_{B/E}$ represents a transformation matrix perturbation in terms of perturbation Euler angles, $\Delta\eta$, and by definition, $\frac{\partial V}{\partial \eta} \Delta\eta \triangleq \Delta T_{B/E} V_E(0)$ where $V_E(0)$ and $T_{B/E}(0)$ represent operating point quantities.

3. Angular rates are expressed in terms of a transformation of Euler angle rates, or $\omega_B = T_{B/E} \dot{\eta}$ and $\Delta\omega_B = \Delta T_{B/E} \dot{\eta}(0) + T_{B/E}(0) \Delta\dot{\eta}$. For our purposes $\dot{\eta}(0) = 0$ since only straight flight conditions are involved.

4. Body reference forces and moments are represented as:

$$\frac{1}{m} F_B \quad \text{and} \quad I_B^{-1} M_B$$

and perturbations as:

$$\frac{1}{m} \Delta F_B = F_{B^v} \Delta V_B^a + F_{B^\omega} \Delta\omega_B^a + F_{B^\delta} \Delta\delta$$

$$I_B^{-1} \Delta M_B = M_{B^v} \Delta V_B^a + M_{B^\omega} \Delta\omega_B^a + M_{B^\delta} \Delta\delta$$

where F_{B^v} , F_{B^ω} , etc. are sets of body reference dimensional stability and control derivatives (e.g., X_u , X_v , X_w , etc.). ΔV_B^a , $\Delta\omega_B^a$ are velocity and velocity gradient components relative to the air mass

with $\Delta V_B^a = \Delta V_B - \Delta V_B^g$, $\Delta \omega_B^a = \Delta \omega_B - \Delta \omega_B^g$ where ΔV_B and ΔV_B^g are inertial velocities and gust velocities respectively, likewise for $\Delta \omega_B$ and $\Delta \omega_B^g$.

As a starting point for forming the desired equations of motion we consider the force equations expressed in an earth-aligned reference frame.

$$\dot{V}_E = T_{E/B} \frac{1}{m} F_B + g_E - \Omega_E^E V_E \quad \swarrow \text{neglect}$$

g_E represents the gravity specific force and $\Omega_E^E V_E$ is the Coriolis force due to earth rotation (which is neglected).

The perturbation equation is thus:

$$\Delta \dot{V}_E = \Delta T_{E/B} \frac{1}{m} F_B(0) + T_{E/B}(0) \frac{1}{m} \Delta F_B + \Delta g_E \quad \swarrow \circ$$

and, the initial conditions are:

$$0 = T_{E/B}(0) \frac{1}{m} F_B(0) + g_E$$

$$\text{or } \frac{1}{m} F_B(0) = -T_{B/E}(0) g_E$$

$$(\text{note } T_{B/E} = T_{E/B}^T)$$

Substituting into the perturbation equation:

$$\Delta \dot{V}_E = -\Delta T_{E/B} T_{B/E}(0) g_E + T_{E/B}(0) \frac{1}{m} \Delta F_B$$

$$\text{and } \frac{\partial G}{\partial \eta} \Delta \eta_B \triangleq \Delta T_{E/B} T_{B/E}(0) g_E$$

recall $\frac{1}{m} \Delta F_B = f(\Delta V_B, \Delta \omega_B, \Delta \delta, \Delta V_B^g, \Delta \omega_B^g)$

and $\Delta V_B = \Delta T_{B/E} V_E(0) + T_{B/E}(0) \Delta V_E$

thus:

$$\begin{aligned} \Delta \dot{V}_E &= - \frac{\partial G}{\partial \eta} \Delta \eta + T_{E/B}(0) F_{B^V} \frac{\partial V}{\partial \eta} \Delta \eta \\ &\quad + T_{E/B}(0) F_{B^V} T_{B/E}(0) \Delta V_E \\ &\quad + T_{E/B}(0) F_{B^\omega} T_{\dot{\eta}}(0) \Delta \dot{\eta} \\ &\quad + T_{E/B}(0) F_{B^\delta} \Delta \delta \\ &\quad + \text{gust terms} \end{aligned}$$

This represents three equations of motion expressed strictly in terms of the desired states, ΔV_E and $\Delta \eta$, and controls, $\Delta \delta$.

The moment equations can be manipulated in a similar manner:

$$\dot{\omega}_B = I_B^{-1} M_B$$

or $\Delta \dot{\omega}_B = I_B^{-1} \Delta M_B$

since $\Delta \omega_B = T_{\dot{\eta}}(0) \Delta \dot{\eta}_B$

$$\Delta \dot{\omega}_B = T_{\dot{\eta}}(0) \Delta \dot{\eta}_B$$

or $\Delta \ddot{\eta}_B = T_{\dot{\eta}}^{-1}(0) \Delta \dot{\omega}_B$

thus:

$$\begin{aligned} \Delta \ddot{\eta} = & T_{\dot{\eta}}^{-1}(0) \frac{M_V}{B} \frac{\partial V}{\partial \eta} \Delta \eta + T_{\dot{\eta}}^{-1}(0) \frac{M_V}{B} T_{B/E}(0) \frac{\Delta V}{E} \\ & + T_{\dot{\eta}}^{-1}(0) \frac{M_{\omega}}{B} T_{\dot{\eta}}(0) \Delta \dot{\eta} + T_{\dot{\eta}}^{-1}(0) \frac{M_{\delta}}{B} \Delta \delta \\ & + \text{gust terms} \end{aligned}$$

Hence, a second set of three equations is formed in terms of the desired states and controls.

As a final step in the general development, consider the introduction of gust disturbances. If the gust components are expressed in a body-fixed earth frame:

$$\Delta V_B g = T_{B/E}(0) \Delta V_E g$$

$$\text{and } \Delta \omega_B g = T_{B/E}(0) \Delta \omega_E g$$

Therefore, the force and moment equations include the following additional gust terms:

$$\Delta \dot{V}_E = \dots - T_{E/B}(0) \frac{F_V}{B} T_{B/E}(0) \Delta V_E g - T_{E/B}(0) \frac{F_{\omega}}{B} T_{B/E}(0) \Delta \omega_E g$$

$$\text{and } \Delta \ddot{\eta}_B = \dots - T_{\dot{\eta}}^{-1}(0) \frac{M_V}{B} T_{B/E}(0) \Delta V_E g - T_{\dot{\eta}}^{-1}(0) \frac{M_{\omega}}{B} T_{B/E}(0) \Delta \omega_E g$$

To summarize, the equations of motion can be expressed in the following manner:

$$\begin{bmatrix} s^2 C_2 + s C_1 + C_0 \end{bmatrix} \begin{bmatrix} \dot{x} \\ \dot{y} \\ \dot{z} \\ \phi \\ \theta \\ \psi \end{bmatrix} = \begin{bmatrix} D \end{bmatrix} \begin{bmatrix} \delta_c \\ \delta_A \\ \delta_B \\ \delta_p \end{bmatrix} + \begin{bmatrix} E \end{bmatrix} \begin{bmatrix} u_g \\ v_g \\ w_g \\ p_g \\ q_g \\ r_g \end{bmatrix}$$

The matrices C_2 , C_1 , C_0 , D , and E can be inferred from the matrix equations shown in Table A-1. The elements of these matrices are given in Table A-2. The required input data is therefore the following sixty-six quantities:

$$\begin{aligned} & \dot{x}_0, \dot{h}_0, \theta_0, \phi_0, \psi_0, g \\ & X_u, X_v, X_w, X_p, X_q, X_r, X_{\delta_c}, X_{\delta_A}, X_{\delta_B}, X_{\delta_p} \\ & Y_u, Y_v, Y_w, Y_p, Y_q, Y_r, Y_{\delta_c}, Y_{\delta_A}, Y_{\delta_B}, Y_{\delta_p} \\ & Z_u, Z_v, Z_w, Z_p, Z_q, Z_r, Z_{\delta_c}, Z_{\delta_A}, Z_{\delta_B}, Z_{\delta_p} \\ & L'_u, L'_v, L'_w, L'_p, L'_q, L'_r, L'_{\delta_c}, L'_{\delta_A}, L'_{\delta_B}, L'_{\delta_p} \\ & M_u, M_v, M_w, M_p, M_q, M_r, M_{\delta_c}, M_{\delta_A}, M_{\delta_B}, M_{\delta_p} \\ & N'_u, N'_v, N'_w, N'_p, N'_q, N'_r, N'_{\delta_c}, N'_{\delta_A}, N'_{\delta_B}, N'_{\delta_p} \end{aligned}$$

TABLE A-1

MATRIX EQUATIONS OF MOTION

$$\begin{bmatrix}
 \left[\begin{array}{c} sI - T_{E/B}(0) \\ F_B^V T_{B/E}(0) \end{array} \right] \\
 \left[\begin{array}{c} -T_{\eta}^{-1}(0) \\ M_B^V T_{B/E}(0) \end{array} \right]
 \end{bmatrix}
 \begin{bmatrix}
 -s T_{E/B}(0) F_B^{\omega} T_{\eta}(0) + \frac{\partial G}{\partial \eta} - T_{E/B}(0) F_B^V \frac{\partial V}{\partial \eta} \\
 s^2 I - s T_{\eta}^{-1}(0) M_B^{\omega} T_{\eta}(0) - T_{\eta}^{-1}(0) M_B^V \frac{\partial V}{\partial \eta}
 \end{bmatrix}
 \begin{bmatrix}
 \Delta V_E \\
 \Delta \eta
 \end{bmatrix}$$

$$=
 \begin{bmatrix}
 \left[\begin{array}{c} T_{E/B}(0) F_B \delta \\ -T_{E/B}(0) F_B^V T_{B/E}(0) \end{array} \right] \\
 \left[\begin{array}{c} T_{\eta}^{-1}(0) M_B \delta \\ -T_{\eta}^{-1}(0) M_B^V T_{B/E}(0) \end{array} \right]
 \end{bmatrix}
 \begin{bmatrix}
 -T_{E/B}(0) F_B^{\omega} T_{B/E}(0) \\
 -T_{\eta}^{-1}(0) M_B^{\omega} T_{B/E}(0)
 \end{bmatrix}
 \begin{bmatrix}
 \Delta \delta \\
 \Delta V_E \\
 \Delta \omega_E
 \end{bmatrix}$$

TABLE A-2
MATRIX ELEMENTS

$$\mathbf{g}_E^T = [0 \ 0 \ g]$$

$$\mathbf{V}_E^T(0) = [\dot{x}_o \ \dot{y}_o \ \dot{z}_o] \quad (\dot{y}_o = 0 \text{ by definition})$$

$$\mathbf{F}_{B/V} = \begin{bmatrix} X_u & X_v & X_w \\ Y_u & Y_v & Y_w \\ Z_u & Z_v & Z_w \end{bmatrix} \quad \mathbf{F}_{B/\omega} = \begin{bmatrix} X_p & X_q & X_r \\ Y_p & Y_q & Y_r \\ Z_p & Z_q & Z_r \end{bmatrix} \quad \mathbf{F}_{B/\delta} = \begin{bmatrix} X_{\delta c} & X_{\delta A} & X_{\delta B} & X_{\delta p} \\ Y_{\delta c} & Y_{\delta A} & Y_{\delta B} & Y_{\delta p} \\ Z_{\delta c} & Z_{\delta A} & Z_{\delta B} & Z_{\delta p} \end{bmatrix}$$

$$\mathbf{M}_{B/V} = \begin{bmatrix} L'_u & L'_v & L'_w \\ M'_u & M'_v & M'_w \\ N'_u & N'_v & N'_w \end{bmatrix} \quad \mathbf{M}_{B/\omega} = \begin{bmatrix} L'_p & L'_q & L'_r \\ M'_p & M'_q & M'_r \\ N'_p & N'_q & N'_r \end{bmatrix} \quad \mathbf{M}_{B/\delta} = \begin{bmatrix} L'_{\delta c} & L'_{\delta A} & L'_{\delta B} & L'_{\delta p} \\ M'_{\delta c} & M'_{\delta A} & M'_{\delta B} & M'_{\delta p} \\ N'_{\delta c} & N'_{\delta A} & N'_{\delta B} & N'_{\delta p} \end{bmatrix}$$

$$\mathbf{T}_{\eta}^T(0) = \begin{bmatrix} 1 & 0 & -\sin \theta_o \\ 0 & \cos \varphi_o & \sin \varphi_o \cos \theta_o \\ 0 & -\sin \varphi_o & \cos \varphi_o \cos \theta_o \end{bmatrix}$$

$$\mathbf{T}_{B/E}(0) = \mathbf{T}_1 \mathbf{T}_2 \mathbf{T}_3$$

$$\mathbf{T}_1 = \begin{bmatrix} 1 & 0 & 0 \\ 0 & \cos \varphi_o & \sin \varphi_o \\ 0 & -\sin \varphi_o & \cos \varphi_o \end{bmatrix} \quad \mathbf{T}_2 = \begin{bmatrix} \cos \theta_o & 0 & -\sin \theta_o \\ 0 & 1 & 0 \\ \sin \theta_o & 0 & \cos \theta_o \end{bmatrix} \quad \mathbf{T}_3 = \begin{bmatrix} \cos \psi_o & \sin \psi_o & 0 \\ -\sin \psi_o & \cos \psi_o & 0 \\ 0 & 0 & 1 \end{bmatrix}$$

$$\Delta \mathbf{T}_{B/E}^T = D\mathbf{T}_1 \mathbf{T}_2 \mathbf{T}_3 \varphi + \mathbf{T}_1 D\mathbf{T}_2 \mathbf{T}_3 \theta + \mathbf{T}_1 \mathbf{T}_2 D\mathbf{T}_3 \psi$$

TABLE A-2 (Concluded)

$$DT_1 = \begin{bmatrix} 0 & 0 & 0 \\ 0 & -\sin \phi_0 & \cos \phi_0 \\ 0 & -\cos \phi_0 & -\sin \phi_0 \end{bmatrix} \quad DT_2 = \begin{bmatrix} -\sin \theta_0 & 0 & -\cos \theta_0 \\ 0 & 0 & 0 \\ \cos \theta_0 & 0 & -\sin \theta_0 \end{bmatrix} \quad DT_3 = \begin{bmatrix} -\sin \psi_0 & \cos \psi_0 & 0 \\ -\cos \psi_0 & -\sin \psi_0 & 0 \\ 0 & 0 & 0 \end{bmatrix}$$

$$\Delta T_{B/E} V_E(0) = \frac{\partial V}{\partial \eta} \Delta \eta$$

$$= \left[[DT_1 \ T_2 \ T_3 \ V_E(0)] \ [T_1 \ DT_2 \ T_3 \ V_E(0)] \ [T_1 \ T_2 \ DT_3 \ V_E(0)] \right] \Delta \eta$$

$$T_{E/B}(0) = T_{B/E}^T(0) = (T_1 \ T_2 \ T_3)^T = T_3^T T_2^T T_1^T$$

$$\Delta T_{E/B} = T_3^T T_2^T DT_1^T \phi + T_3^T DT_2^T T_1^T \theta + DT_3^T T_2^T T_1^T \psi$$

$$\Delta T_{E/B} T_{B/E}(0) \frac{g}{E} \triangleq \frac{\partial G}{\partial \eta} \Delta \eta = g \begin{bmatrix} \cos \theta_0 \sin \psi_0 & \cos \psi_0 & 0 \\ -\cos \theta_0 \cos \psi_0 & \sin \psi_0 & 0 \\ 0 & 0 & 0 \end{bmatrix} \Delta \eta$$

$$T_{\eta}^{-1} = \begin{bmatrix} 1 & \sin \phi_0 \tan \theta_0 & \cos \phi_0 \tan \theta_0 \\ 0 & \cos \phi_0 & -\sin \phi_0 \\ 0 & \sin \phi_0 / \cos \theta_0 & \cos \phi_0 \sec \theta_0 \end{bmatrix}$$

The following matrix equations of motion and corresponding transformation matrices serve as examples and correspond to cases included in the compiled data. The cases include:

Case 4 OH-6A in Hover (Table A-3)

Case 8 OH-6A at 60 kt (Table A-4)

TABLE A-3

SAMPLE OF EQUATIONS OF MOTION AND TRANSFORMATION MATRICES
(OH-6A, HOVER)

	1	2	3	4	5	6	7	8	9	10	11	12
	δ_C	δ_B	δ_A	b_p	u_g	v_g	w_L	p_L	q_L	r_L	s_L	t_L
1	0.0000	0.0000	0.0000	0.0000	0.0000	0.0000	0.0000	0.0000	0.0000	0.0000	0.0000	0.0000
2	0.0000	0.0000	0.0000	0.0000	0.0000	0.0000	0.0000	0.0000	0.0000	0.0000	0.0000	0.0000
3	0.0000	0.0000	0.0000	0.0000	0.0000	0.0000	0.0000	0.0000	0.0000	0.0000	0.0000	0.0000
4	0.0000	0.0000	0.0000	0.0000	0.0000	0.0000	0.0000	0.0000	0.0000	0.0000	0.0000	0.0000
5	0.0000	0.0000	0.0000	0.0000	0.0000	0.0000	0.0000	0.0000	0.0000	0.0000	0.0000	0.0000
6	0.0000	0.0000	0.0000	0.0000	0.0000	0.0000	0.0000	0.0000	0.0000	0.0000	0.0000	0.0000

$$\frac{\partial V}{\partial \eta} = \begin{bmatrix} 0.0000 & 0.0000 & 0.0000 \\ 0.0000 & 0.0000 & 0.0000 \\ 0.0000 & 0.0000 & 0.0000 \end{bmatrix}$$

$$\frac{\partial G}{\partial \eta} = \begin{bmatrix} 0.0000 & 0.3217E-02 & 0.0000 \\ -0.3216E-02 & 0.0000 & 0.0000 \\ 0.0000 & 0.0000 & 0.0000 \end{bmatrix}$$

* Vertical array of three corresponds to coefficients of s^2 , s , s^0 respectively.

TABLE A-4

SAMPLE OF EQUATIONS OF MOTION AND TRANSFORMATION MATRICES
(OH-6A, 60 KI)

	1	2	3	4	5	6	7	8	9	10																
1	\dot{x}	\dot{y}	\dot{z}	$\dot{\varphi}$	$\dot{\theta}$	$\dot{\psi}$	δ_C	δ_B	δ_A	δ_P	u_E	v_E	w_E	p_E	q_E	r_E	δ_C									
2	\ddot{x}	\ddot{y}	\ddot{z}	$\ddot{\varphi}$	$\ddot{\theta}$	$\ddot{\psi}$	\dot{x}	\dot{y}	\dot{z}	$\dot{\varphi}$	$\dot{\theta}$	$\dot{\psi}$	\dot{p}	\dot{q}	\dot{r}	$\dot{\delta}_C$	$\dot{\delta}_B$	$\dot{\delta}_A$	$\dot{\delta}_P$	\dot{u}_E	\dot{v}_E	\dot{w}_E	\dot{p}_E	\dot{q}_E	\dot{r}_E	$\dot{\delta}_C$
3	\ddot{x}	\ddot{y}	\ddot{z}	$\ddot{\varphi}$	$\ddot{\theta}$	$\ddot{\psi}$	\dot{x}	\dot{y}	\dot{z}	$\dot{\varphi}$	$\dot{\theta}$	$\dot{\psi}$	\dot{p}	\dot{q}	\dot{r}	$\dot{\delta}_C$	$\dot{\delta}_B$	$\dot{\delta}_A$	$\dot{\delta}_P$	\dot{u}_E	\dot{v}_E	\dot{w}_E	\dot{p}_E	\dot{q}_E	\dot{r}_E	$\dot{\delta}_C$
4	\ddot{x}	\ddot{y}	\ddot{z}	$\ddot{\varphi}$	$\ddot{\theta}$	$\ddot{\psi}$	\dot{x}	\dot{y}	\dot{z}	$\dot{\varphi}$	$\dot{\theta}$	$\dot{\psi}$	\dot{p}	\dot{q}	\dot{r}	$\dot{\delta}_C$	$\dot{\delta}_B$	$\dot{\delta}_A$	$\dot{\delta}_P$	\dot{u}_E	\dot{v}_E	\dot{w}_E	\dot{p}_E	\dot{q}_E	\dot{r}_E	$\dot{\delta}_C$
5	\ddot{x}	\ddot{y}	\ddot{z}	$\ddot{\varphi}$	$\ddot{\theta}$	$\ddot{\psi}$	\dot{x}	\dot{y}	\dot{z}	$\dot{\varphi}$	$\dot{\theta}$	$\dot{\psi}$	\dot{p}	\dot{q}	\dot{r}	$\dot{\delta}_C$	$\dot{\delta}_B$	$\dot{\delta}_A$	$\dot{\delta}_P$	\dot{u}_E	\dot{v}_E	\dot{w}_E	\dot{p}_E	\dot{q}_E	\dot{r}_E	$\dot{\delta}_C$
6	\ddot{x}	\ddot{y}	\ddot{z}	$\ddot{\varphi}$	$\ddot{\theta}$	$\ddot{\psi}$	\dot{x}	\dot{y}	\dot{z}	$\dot{\varphi}$	$\dot{\theta}$	$\dot{\psi}$	\dot{p}	\dot{q}	\dot{r}	$\dot{\delta}_C$	$\dot{\delta}_B$	$\dot{\delta}_A$	$\dot{\delta}_P$	\dot{u}_E	\dot{v}_E	\dot{w}_E	\dot{p}_E	\dot{q}_E	\dot{r}_E	$\dot{\delta}_C$

$$\tau_{B/E}(t) = \begin{bmatrix} 0.99992 & 0.00000 & 0.00000 & -0.10102 & -0.10102 & 0.00000 \\ -0.27192 & 0.00000 & 0.00000 & 0.99992 & 0.99992 & 0.00000 \\ 0.10102 & 0.00000 & 0.00000 & 0.26652 & 0.26652 & 0.00000 \end{bmatrix} = \begin{bmatrix} 0.00000 & -0.10232 & 0.00000 \\ 0.10232 & 0.00000 & 0.00000 \\ 0.27488 & 0.00000 & 0.00000 \end{bmatrix}$$

$$\tau_{i_1} = \begin{bmatrix} 0.10000 & 0.00000 & -0.10102 & 0.00000 \\ 0.00000 & 0.99992 & 0.00000 & -0.26652 \\ 0.00000 & 0.26652 & 0.00000 & 0.99992 \end{bmatrix} = \begin{bmatrix} 0.00000 & 0.32172 & 0.00000 \\ -0.32172 & 0.00000 & 0.00000 \\ 0.00000 & 0.00000 & 0.00000 \end{bmatrix}$$

* Vertical array of three corresponds to coefficients of s^2 , s , s^0 respectively.

APPENDIX B

SUMMARY OF MULTILoop SYSTEM RELATIONSHIPS

The following is a summary of multiloop system relationships that are useful when using the transfer function data provided in this compilation. For a more complete treatment the reader should consult Chapter 3-5 of Ref. B1. Also, numerous examples are included in Volume Two of this report (Ref. B3).

Consider the following example of a set of linearized equations of motion involving four states and three controls (or disturbances):

$$\begin{bmatrix} a_{11}(s) & a_{12}(s) & a_{13}(s) & a_{14}(s) \\ a_{21}(s) & a_{22}(s) & a_{23}(s) & a_{24}(s) \\ a_{31}(s) & a_{32}(s) & a_{33}(s) & a_{34}(s) \\ a_{41}(s) & a_{42}(s) & a_{43}(s) & a_{44}(s) \end{bmatrix} \begin{bmatrix} x_1(s) \\ x_2(s) \\ x_3(s) \\ x_4(s) \end{bmatrix} = \begin{bmatrix} b_{11}(s) & b_{12}(s) & b_{13}(s) \\ b_{21}(s) & b_{22}(s) & b_{23}(s) \\ b_{31}(s) & b_{32}(s) & b_{33}(s) \\ b_{41}(s) & b_{42}(s) & b_{43}(s) \end{bmatrix} \begin{bmatrix} \delta_1(s) \\ \delta_2(s) \\ \delta_3(s) \end{bmatrix}$$

Note that each element in the above matrices can be a polynomial of s .

The characteristic determinant is given by:

$$\Delta(s) = \det \begin{bmatrix} a_{11} & a_{12} & a_{13} & a_{14} \\ a_{21} & a_{22} & a_{23} & a_{24} \\ a_{31} & a_{32} & a_{33} & a_{34} \\ a_{41} & a_{42} & a_{43} & a_{44} \end{bmatrix}$$

Examples of numerators and coupling numerators are:

$$N_{\delta_1}^{x_1}(s) = \det \begin{bmatrix} b_{11} & a_{12} & a_{13} & a_{14} \\ b_{21} & a_{22} & a_{23} & a_{24} \\ b_{31} & a_{32} & a_{33} & a_{34} \\ b_{41} & a_{42} & a_{43} & a_{44} \end{bmatrix} \quad (\text{Type 0 numerator})$$

$$N_{\delta_1 \delta_3}^{x_1 x_4}(s) = \det \begin{bmatrix} b_{11} & a_{12} & a_{13} & b_{13} \\ b_{21} & a_{22} & a_{23} & b_{23} \\ b_{31} & a_{32} & a_{33} & b_{33} \\ b_{41} & a_{42} & a_{43} & b_{43} \end{bmatrix} \quad (\text{Type 1 numerator})$$

$$N_{\delta_3 \delta_1 \delta_2}^{x_2 x_4 x_1}(s) = \det \begin{bmatrix} b_{12} & b_{13} & a_{13} & b_{11} \\ b_{22} & b_{23} & a_{23} & b_{21} \\ b_{32} & b_{33} & a_{33} & b_{31} \\ b_{42} & b_{43} & a_{43} & b_{41} \end{bmatrix} \quad (\text{Type 2 numerator})$$

The largest type coupling numerator is limited by the number of independent variables such as controls and gust disturbances — e.g., Type 1 is the maximum for one control and one disturbance or two controls, Type 2 is the maximum for two controls and one disturbance or three controls, etc.

Also, by way of example, useful numerator identities include:

$$\frac{x_1 x_2}{N_{\delta_1 \delta_2}} = \frac{x_2 x_1}{N_{\delta_2 \delta_1}} = -\frac{x_1 x_2}{N_{\delta_2 \delta_1}}$$

$$\frac{x_1 x_1}{N_{\delta_1 \delta_2}} = \frac{x_1 x_2}{N_{\delta_1 \delta_1}} = 0$$

$$\frac{x_1 x_2}{N_{\delta_1 \delta_2}} = \det \frac{\begin{bmatrix} x_1 & x_1 \\ N_{\delta_1} & N_{\delta_2} \\ x_2 & x_2 \\ N_{\delta_1} & N_{\delta_2} \end{bmatrix}}{\Delta} = \frac{1}{\Delta} \left(\frac{x_1}{N_{\delta_1}} \frac{x_2}{N_{\delta_2}} - \frac{x_1}{N_{\delta_2}} \frac{x_2}{N_{\delta_1}} \right)$$

$$\frac{x_1 x_2 x_3}{N_{\delta_1 \delta_2 \delta_3}} = \det \frac{\begin{bmatrix} x_1 & x_1 & x_1 \\ N_{\delta_1} & N_{\delta_2} & N_{\delta_3} \\ x_2 & x_2 & x_2 \\ N_{\delta_1} & N_{\delta_2} & N_{\delta_3} \\ x_3 & x_3 & x_3 \\ N_{\delta_1} & N_{\delta_2} & N_{\delta_3} \end{bmatrix}}{\Delta^2} = \frac{\begin{aligned} & \frac{x_1}{N_{\delta_1}} \frac{x_2}{N_{\delta_2}} \frac{x_3}{N_{\delta_3}} \\ & + \frac{x_1}{N_{\delta_2}} \frac{x_2}{N_{\delta_3}} \frac{x_3}{N_{\delta_1}} \\ & + \frac{x_1}{N_{\delta_3}} \frac{x_2}{N_{\delta_1}} \frac{x_3}{N_{\delta_2}} \end{aligned}}{\Delta}$$

A more general description of the expansion of higher type coupling numerators is given in Ref. B2.

In order to appreciate the application of some of the foregoing numerators and coupling numerators, consider the following block diagram:

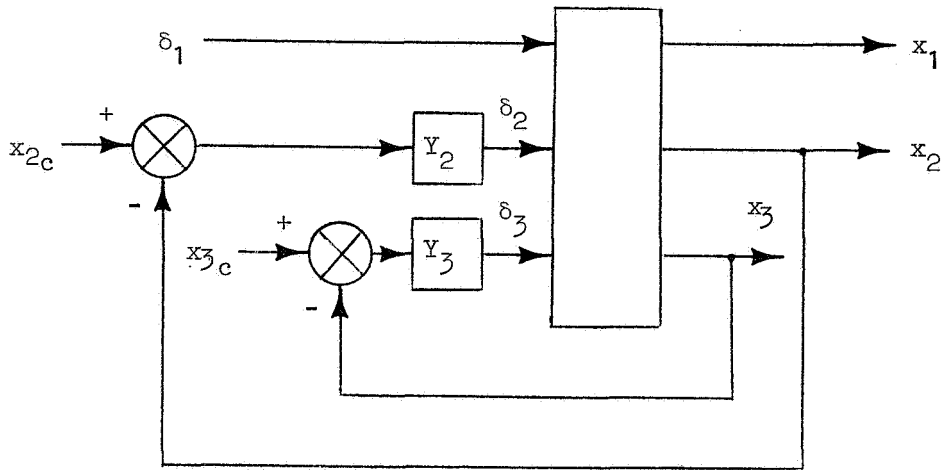

The following are examples of transfer functions involving multiloop feedbacks for this block diagram.

The exact x_1/δ_1 transfer function is:

$$\left. \frac{x_1}{\delta_1} \right|_{\substack{x_2 \rightarrow \delta_2 \\ x_3 \rightarrow \delta_3}} = \frac{N_{\delta_1} + Y_2 N_{\delta_2} \delta_1 + Y_3 N_{\delta_3} \delta_1 + Y_2 Y_3 N_{\delta_2 \delta_3} \delta_1}{\Delta + Y_2 N_{\delta_2} + Y_3 N_{\delta_3} + Y_2 Y_3 N_{\delta_2 \delta_3}}$$

The x_1/δ_1 transfer function with x_2 and x_3 constrained by δ_2 and δ_3 , respectively, is:

$$\left. \frac{x_1}{\delta_1} \right|_{x_2, x_3} = \lim_{\substack{y_2 \rightarrow \infty \\ y_3 \rightarrow \infty}} \left(\left. \frac{x_1}{\delta_1} \right|_{\substack{x_2 \rightarrow \delta_2 \\ x_3 \rightarrow \delta_3}} \right) = \frac{N_{\delta_2 \delta_3} \delta_1}{N_{\delta_2 \delta_3}}$$

REFERENCES

- B1 McRuer, Duane, Irving Ashkenas, and Dunstan Graham, Aircraft Dynamics and Automatic Control, Princeton University Press, Princeton, New Jersey, 1973.
- B2 Hofmann, L. G., G. L. Teper, and R. F. Whitbeck, "Application of Frequency Domain Multivariable Control Synthesis Techniques to an Illustrative Problem in Jet Engine Control," Systems Technology, Inc. Paper No. 209, Presented at NEC International Forum on Multivariable Control, Chicago, Illinois, October 13-14, 1977.
- B3 Heffley, Robert K., A Compilation and Analysis of Helicopter Handling Qualities Data, Volume Two: Data Analysis, Systems Technology, Inc. TR 1087-2, March 1978.