

Available from originating office only

(NASA-TM-81149) QUIET SHORT-HAUL RESEARCH
AIRCRAFT FAMILIARIZATION DOCUMENT (NASA)
96 p

N80-14108

CSSL 01C

00/05 Unclas
46420

Quiet Short-Haul Research Aircraft Familiarization Document

Robert C. McCracken

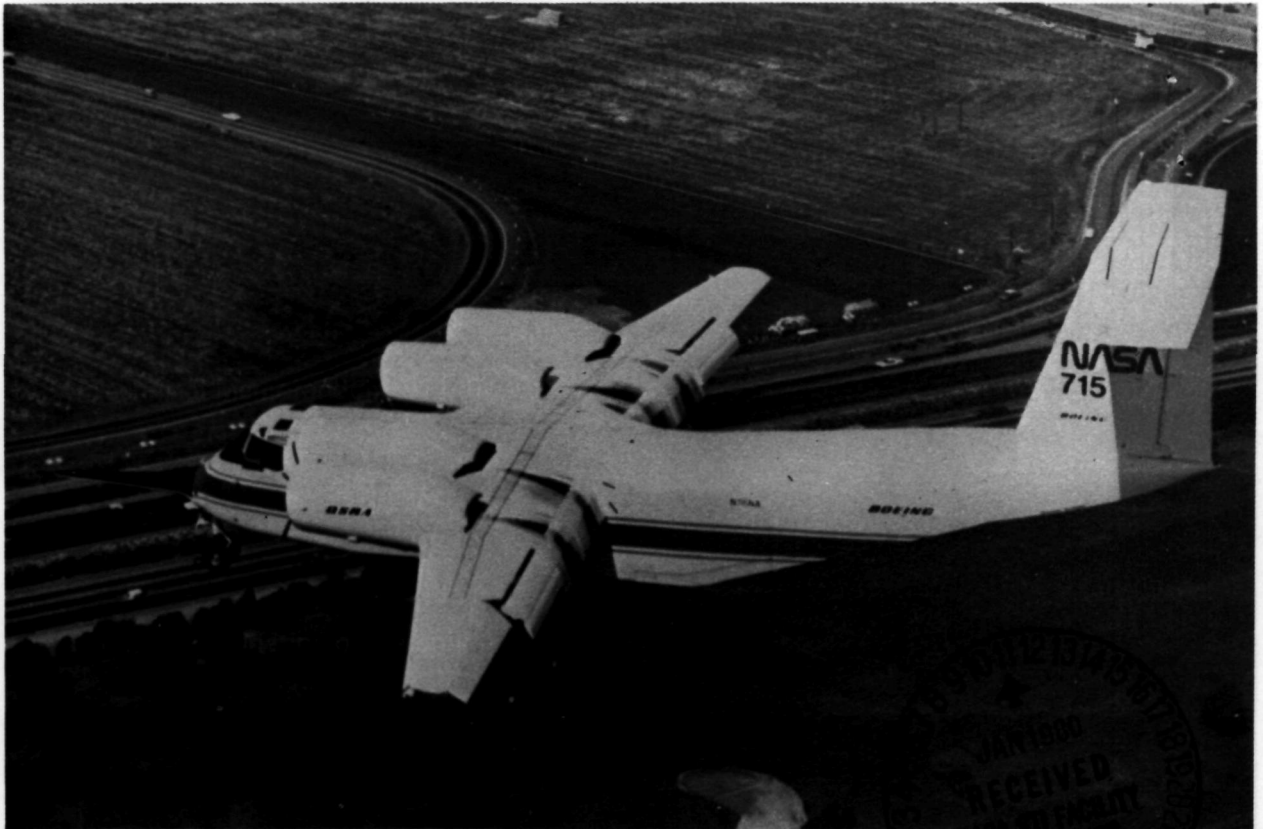

NASA
National Aeronautics and
Space Administration



November 1979

Quiet Short-Haul Research Aircraft Familiarization Document

Robert C. McCracken, Ames Research Center, Moffett Field, California



National Aeronautics and
Space Administration

Ames Research Center
Moffett Field, California 94035

TABLE OF CONTENTS

	<u>Page</u>
1. INTRODUCTION.	1
2. AIRCRAFT DESCRIPTION.	2
3. AIRCRAFT SPECIFICATIONS	2
3.1 Weights and Inertias	3
3.2 Center of Gravity.	4
3.3 Dimensions and General Data.	4
3.4 Control Surface Areas, Deflections and Rates	5
3.5 Cargo Area	5
3.6 Landing Gear	5
4. STRUCTURAL DESIGN CRITERIA.	6
4.1 Design Speeds.	6
4.2 Limit Load Factors	6
4.3 Structural Load Factors.	6
4.4 Service Life	7
5. PERFORMANCE AND NOISE	7
5.1 Takeoff.	7
5.2 Stopping Distance.	7
5.3 Climb and Descent.	7
5.4 Range and Endurance.	7
5.5 Noise.	8
6. PROPULSION.	8
6.1 Configuration and Powerplant	8
6.2 Powerplant	9
6.3 Nacelle and Powerplant Installation.	9
6.4 Engine Performance	9
6.5 Acoustic Treatment	9
6.6 Nacelle and Engine Instrumentation	9
7. BOUNDARY-LAYER CONTROL SYSTEM	10
8. FLIGHT-CONTROL SYSTEM	10
8.1 Basic Flight-Control System	10
8.2 Stability Augmentation System.	12
8.3 Electric Command System.	12
9. FLIGHT-TEST INSTRUMENTATION SYSTEM.	13
9.1 Sensors and Transducers.	13
9.2 Tape Recorder.	13
9.3 Time-Code Generator.	14
9.4 Active Network Panels.	14
9.5 Parameter List	14

	<u>Page</u>
10. OPERATIONAL SUBSYSTEMS.	14
10.1 Fuel System	14
10.2 Hydraulic System.	14
10.3 Electrical System	15
10.4 Environmental Control System.	15
10.5 Communications and Navigation Systems	15
10.6 Crew Station.	16
10.7 Emergency Egress.	17
11. GROUND SERVICING AND HANDLING	17
11.1 Ground Service Equipment.	17
11.2 Fluid Requirements.	17
11.3 Airplane Grounding.	18
11.4 Servicing	18
12. DOCUMENTATION LIST.	18
TABLES	19
FIGURES.	23

QUIET SHORT-HAUL RESEARCH AIRCRAFT FAMILIARIZATION DOCUMENT

Robert C. McCracken

Ames Research Center

1. INTRODUCTION

This document summarizes the Quiet Short-Haul Research Aircraft (QSRA) design features and performance characteristics and describes the flight-test data-acquisition system. The information contained herein was obtained during the design, ground test, and first 30 hr of flight testing, and should therefore be treated as preliminary data.

Propulsive-lift technology is needed by government and industry to develop options for future U.S. civil short-haul transportation, to compete in foreign markets, and to improve military tactical airlift capability. The objective of NASA's Quiet Propulsive-Lift Technology (QPLT) program is to provide data which: (1) will significantly reduce the technical risk associated with the development by industry of civil and military propulsive-lift transports, and (2) will permit government regulatory agencies to establish realistic criteria for certification of commercial propulsive-lift aircraft.

The QSRA (fig. 1) is the major element of the QPLT program. The airplane is a flight research facility which will be used for advanced flight experiments. It has very high performance in the low-speed regime, very low noise levels, and a versatile flight-control system. The research application of the aircraft is focused on takeoff and landing and other terminal area operations associated with the propulsive-lift mode of flight.

The QSRA was designed and built by the Boeing Commercial Airplane Company. It is a modified deHavilland C-8A Buffalo, with new wing and nacelles and four AVCO-Lycoming YF-102 engines. It employs the upper-surface-blowing propulsive lift concept. Engine bleed air provides trailing-edge (aileron) blowing for boundary-layer control. The first flight occurred in July, 1978; the aircraft was delivered to Ames Research Center in August.

Cost was second only to safety in QSRA program priorities. Consequently, the Boeing contract contained performance goals rather than specifications. This permitted design tradeoffs between research capability and cost, with the intent to maximize the overall capability of the airplane while remaining within the project budget. The contractor was encouraged to suggest changes that resulted in increased research capability at equal cost or reductions in cost with no performance decrement. Extensive use of government-furnished equipment salvaged from other airplanes (fuselage, engines, accessories, etc.) also reduced cost. This resulted in a very austere airplane, but one with a very high research capability.

The Quiet Short-Haul Aircraft Office at Ames is responsible for management of the QSRA flight experiments program. Experiments are planned in various technical disciplines: aerodynamics, propulsion, stability and control, handling qualities, avionics and flight-control systems, acoustics, loads and structures, operating systems, human factors, trailing-vortex phenomena, and airworthiness/certification criteria. Investigators from various organizations at Ames and other NASA centers will participate in the definition and conduct of these experiments. However, it is NASA's intent that the QSRA be a national facility. Investigators from industry, the academic community, and other government agencies are encouraged to propose and participate in flight experiments.

2. AIRCRAFT DESCRIPTION

The Quiet Short-Haul Research Aircraft (fig. 2) is designed to demonstrate quiet propulsive-lift technology in a configuration that realistically represents a practical and efficient high-subsonic cruise transport. As the emphasis is on terminal area operation, the airplane is fixed in the low-speed configuration, with the leading-edge devices deployed and landing gear locked down. Virtually no attempt has been made to reduce drag for cruise performance, although to make the airplane more representative of a commercial transport, it incorporates such fuel-conservative features as a high-aspect ratio, moderately swept wing, a supercritical airfoil, and a high-performance inlet without acoustic rings.

The QSRA uses a DeHavilland C-8A Buffalo fuselage and landing gear with modifications and a C-8A empennage, modified for powered elevator operation and fitted with SAS actuators. The primary feature is the new wing with internal fuel tanks, fitted with four new nacelles forward and over the wing which house Lycoming YF-102 turbofan engines. The new configuration details include the advanced airfoil, upper-surface-blowing powered lift, aileron boundary-layer control blowing, and an advanced flight-control system featuring electrically commanded fly-by-wire spoilers and flaps. Three-axis stability augmentation is provided. An airborne flight-test instrumentation system is installed in the aft cabin. Due to its research nature, the airplane carries only a pilot and copilot. There is provision for additional experimental payload in the cabin area. While space is abundant, the airplane is configured to carry no observers — only the pilot and copilot.

3. AIRCRAFT SPECIFICATIONS

The data presented herein represents the current configuration.

3.1 Weights and Inertias

3.1.1 Airplane weights-

	<u>lb</u>
Takeoff gross weight	48820
Design landing weight	48000
Zero fuel weight	38720
Operational empty weight (No flight-test instrumentation)	36600
Maximum taxi weight	48820

3.1.2 Group weights-

	<u>lb</u>	<u>X-C.G. - in.</u>
Wing	8742	389.2
Horizontal tail	614	906.9
Vertical tail	494	840.8
Body	6121	410.0
Main landing gear	2098	392.3
Nose landing gear	288	55.7
Nacelle and strut	4454	290.1
Total structure	(22811)	(396.1)
Engines	4960	281.6
Engine accessories	317	255.8
Engine controls	92	221.7
Starting system	152	268.9
Total propulsion group	(5791)	(280.9)
Instruments	198	86.3
Surface controls	1356	437.4
Hydraulics	958	388.0
Pneumatics	392	285.2
Electrical	1311	230.0
Electronics	491	173.8
Boundary-layer control	948	199.5
Furnishings	331	354.7
Cargo handling	101	331.8
Emergency equipment	308	290.5
Air conditioning	128	142.5
Anti-icing	20	545.5
Total fixed equipment	(6562)	(310.8)
Ballast	872	837.0
Exterior paint	115	439.0
Calculated to actual increment	-321	107.2
Manufacturer empty weight	35830	
Standard and operational items	770	220.4
Operational empty weight	36600	372.1
Flight-test equipment	2120	435.5
Maximum zero fuel weight	38720	375.5

3.1.3 Airplane inertias (maximum gross weight)-

I_{xx} (roll)	193,660 slug ft ²
I_{yy} (pitch)	272,620 slug ft ²
I_{zz} (yaw)	420,700 slug ft ²
I_{zz} (product)	23,210 slug ft ²

The variation in inertia with airplane gross weight is shown in figures 3(a), (b), (c), and (d).

3.2 Center of Gravity

The center of gravity range for the QSRA is shown in figure 4.

3.3 Dimensions and General Data

	<u>Wing</u>	<u>Horizontal tail</u>	<u>Vertical tail</u>
Area, ft ²	600	233	152
Span, ft	73.5	32.0	13.58
Chord - root, in.	150.7	100	168
Chord-tip, in.	45.2	75	100
Mean aerodynamic chord, in.	107.4	88	137
Aspect ratio	9.0	4.4	1.22
Incidence, deg	4.5	3° L.E. UP	-
Dihedral, deg	0	0	-
Sweep C/4, deg	15.0	3.0	17.37
Taper ratio	0.30	0.75	0.60
Thickness ratio - side of body, %	18.54	14	14
Thickness ratio - tip, %	15.12	12	14

3.4 Control Surface Areas, Deflections and Rates

	<u>Area</u> ft/APL	<u>Deflection,</u> deg	<u>Maximum rate,</u> deg/sec
Aileron	32.2	-20, +50	±40
USB flaps	105	0, 66	0-30, ±10 30-66, ±6.74
Outboard flaps	40.2	0, 59	±5
Spoilers	33.7	60 up	±50
Direct lift control - biased to 13° up with ±13° travel about that point			
Elevator	81.6	-25, +15	±45
Rudder	60.8	±25	±35

3.5 Cargo Area

The main cabin area of the QSRA, shown in figure 5, is extensive, but due to existing installations, the clear floor area is limited to approximately 7 ft by 10 ft. Restrictions in access limit package sizes to 30 in. wide and 48 in. high.

3.6 Landing Gear

Main landing gear-

Wheels per side	2
Wheel spacing	25 in.
Tire size, type, rating	32 × 11.5 - 15 ch, 12-ply
Inflation pressure	90 psi
Strut deflection	24 in.

Nose landing gear-

Wheels	2
Wheel spacing	18 in.
Tire size, type, rating	8.90 × 12.50, Type 3, 6-ply
Inflation pressure	42 psi
Strut deflection	18 in.

4. STRUCTURAL DESIGN CRITERIA

4.1 Design Speeds

The design structural limit speeds are listed below:

V_G	Maximum ground operation speed	120 Knots
V_D	Design dive speed	190
V_{MO}, V_C	Maximum operating and cruise speed	160
V_A	Design maneuvering speed	142
V_B	Gust slowdown speed	137
V_{MC}	Minimum controllable airspeed (1 g flight CEI)	55
V_{SB}	Speedbrake extend limit	190
V_F	Flap extend speeds are listed in the following table:	

<u>Flight configuration</u>	<u>Outboard flaps, deg</u>	<u>USB flaps, deg</u>	<u>Limit AS Knots</u>
Go-around from CTOL	30	0	140
Takeoff, CTOL landing	59	0	130
Go-around from STOL	59	<40	120
STOL landing	59	>40	100

4.2 Limit Load Factors

The QSRA is limited to the maneuver load factors in the following table. V-n diagrams are provided in figure 6.

<u>Configuration</u>	<u>Positive load factor, g</u>	<u>Negative load factor, g</u>
Flaps up, to 160 knots	2.25	0.5
Flaps up, above 160 knots	2.25	0.0
Flaps extended	2.0	0.0

4.3 Structural Load Factors

The structural design loads are 1.74 ($1.5 \times 1.15 = 1.73$) times the limit loads. The 1.15 factor was used in lieu of a structural test program.

4.4 Service Life

The QSRA has been designed for a service life of not less than 2000 flights or 500 flight hours without replacement or overhaul of major components.

5. PERFORMANCE AND NOISE

5.1 Takeoff

Takeoff performance for QSRA is shown in figure 7. The data provided for field length are based on the longest of:

1. 1.15 times the distance to clear a 35-ft obstacle with all engines operating.
2. The distance to 35-ft altitude with an outboard engine failed at the critical failure speed.
3. The distance to accelerate to the critical speed and stop. Airplane configuration is with takeoff flaps (outboard flaps 59°, USB flaps retracted), and assumes thrust is *not* increased on remaining engines after an engine failure.

5.2 Stopping Distance

Landing ground distance is given in figures 8(a) and 8(b) for various approach speeds, flightpath angles and temperatures. Distances have been multiplied by 1.67 as is done for Federal Air Regulation distances. Nonfactored distances are provided in figure 8(c).

5.3 Climb and Descent

5.3.1. *Climb*- Figure 9(a) gives fuel, distance, and time to climb for cruise configuration, standard day, with boundary-layer control switches off. Figures 9(b), (c), and (d) give climb performance at sea level, 5,000 ft and 10,000 ft with BLC switches off. Figure 9(e) gives climb performance at 15,000 ft with the BLC switches off.

5.3.2. *Descent*- The descent capability of the QSRA in the cruise configuration at 50% N_L is shown in figure 10.

5.4 Range and Endurance

The range for a ferry mission for a takeoff gross weight of 48,820 lb (10,100 lb of fuel) is 256 n. mi., with an elapsed time of 128 min. This mission is accomplished as shown below:

<u>Segment</u>	<u>Fuel used, lb</u>	<u>Time, min</u>	<u>Distance, n. mi.</u>
Taxi	330	15	
Takeoff, climb to 1500 ft	190	.9	
Climb to 15,000 ft	1030	8.6	19
Cruise	6220	8.2	220
Descent to 1500 ft	230	7.2	17
Land	300	3.8	
Taxi	<u>220^a</u>	<u>10.0</u>	
Totals	8520	127.5	256

^aTaken from reserve.

A 30-min reserve (1,800 lb of fuel) was used. BLC switches are turned off except for landing. A schematic of a STOL mission is shown in figure 11. The airplane weight is 45,000 lb for this case. There is enough fuel (1,800 lb reserve) for 12 cycles.

5.5 Noise

The community noise generated by QSRA estimated at first flight were as follows:

500-ft sideline noise

Takeoff, 50,000-lb aircraft, 2,000-ft runway	91 EPNdB
Landing, 48,000-lb aircraft, $\gamma = -7.5^\circ$, 70 knots	89 EPNdB

The area within the 90 EPNdB footprint for a combined takeoff and landing, scaled to a 150,000-lb airplane, is estimated to be approximately 1 mi².

6. PROPULSION

6.1 Configuration and Powerplant

The QSRA propulsion system consists of four AVCO-Lycoming YF-102 engines mounted in nacelles above and forward of the wings as shown in figure 12. These prototype engines, obtained from the Air Force A-9A program, were refurbished and updated by the engine manufacturer. The principal elements of this update consisted of a fan containment ring, combustor case bleed ports, and new oil coolers.

6.2 Powerplant

A cutaway view of the engine is shown in figure 13(a). The engine is basically a T-55 gas producer with the addition of a two-stage turbine driving a single-stage fan through 2.3 to 1 reduction gears. Engine geometry, dimensions, and uninstalled performance are shown in figure 13(b). The engines are provided with an overspeed protection system that senses the power turbine shaft speed and shuts off the fuel at the fuel control if the turbine exceeds 103% of its design speed.

6.3 Nacelle and Powerplant Installation

The layout of the nacelle is shown in figure 14(a). The QSRA nacelle and powerplant installation is unusual in that the engine serves as an integrated part of the nacelle structure, supporting the inlet and nose cowl, core cowl, primary nozzle, and engine-driven accessories (fig. 14(b)). The remainder of the nacelle is the structural cowl and nozzle assembly, which mounts on the wing and supports the engine buildup. The nozzle assembly mixes the fan and core air and terminates in a D-shaped opening that shapes the flow into a thin sheet, which in turn flows over the wing and upper-surface-blowing (USB) flaps to provide lift.

6.4 Engine Performance

The relationship of thrust and fan speed for the YF-102 engines is shown in figure 15(a), which also shows the relationship between core speed and fan speed. The effect of ambient temperature on installed thrust is shown in figure 15(b).

6.5 Acoustic Treatment

The location of the acoustic liners in the nacelle is shown in figure 16. The liners in the fan duct are found on the structural cowl and the core cowl, and are composed of perforated face sheets, aluminum honeycomb cores, and solid back sheets. They cover about 30 in. of the duct length and are estimated to provide 12 PNdB of aft fan attenuation. The inlet lining is of double wall construction with perforated aluminum face sheet and septum, aluminum honeycomb cores, and solid aluminum backing sheets.

6.6 Nacelle and Engine Instrumentation

Each inlet has four static pressure taps located 90° apart slightly downstream of the throat area. The liners are not removable at this time and therefore the ability to add inlet instrumentation is limited. When the serial number 2 engine is installed on the left inboard location, it contains the instrumentation described in section 9. The operation of this engine was documented during the ground test and correlated with each of the other engines and with earlier test cell data.

7. BOUNDARY-LAYER CONTROL SYSTEM

The boundary-layer control (BLC) system improves the performance of the QSRA by enabling operation with good handling qualities and increased angle-of-attack margins down to very low airspeeds. Each outboard engine provides air for an opposite aileron, as shown in figure 17.

Two key elements of the BLC system are the mixing ejector and its associated servo-pressure regulator valve, which are located in the outboard nacelles behind the fan and below the core. The ejector, shown in figure 18, mixes high-pressure core bleed air and fan air to provide constant duct pressure with varying engine speeds. The ejector itself uses a fixed geometry mixing section with an elliptical centerbody, and a series of high-pressure nozzles located circumferentially between the duct wall and the centerbody. The core bleed is limited to 10% by the high-pressure nozzles, while the fan bleed is limited to 3% by the duct size. Figure 18 shows the net blowing momentum of a BLC nozzle as provided by the ejector on the upper curve without regulation, while the lower curve shows the value with the pressure regulator valve in operation, sensing pressure downstream of the ejector and controlling the high-pressure bleed air to the ejector. The regulator gives no bleed at high engine speeds where the fan flow is adequate, and up to 10% bleed at low speeds. The ensuing loss of thrust due to core bleed only occurs at low throttle settings where high power is not required.

The regulated air is routed through ducts to a series of adjacent nozzles which direct the flow over the ailerons, significantly improving the control effectiveness during low-speed, high-lift operation. Automatic cutoff of the regulated core air is provided to protect the engines from overbleeding at high power, which could occur with a blown BLC duct.

8. FLIGHT-CONTROL SYSTEM

8.1 Basic Flight-Control System

The Quiet Short-Haul Research Aircraft flight-control system is shown schematically in figure 19(a), and pictorially in figure 19(b). The airplane can be flown from either the right- or left-hand seat, although the cockpit instrument panel and controls are optimized for flying from the left seat. In addition, the control wheel on the left side is fitted with force and position sensors, which furnish inputs to the stability and control augmentation system. All primary flight controls are conventional. Power levers are located in an overhead throttle console.

8.1.1 Lateral control system- The lateral control system is schematically shown in figure 20(a). Roll control is achieved using ailerons and spoilers. The centering detent and wheel force gradient are provided mechanically. Aileron trim is provided by electrically repositioning the feel detent. The ailerons are drooped as a function of outboard flap position and operate about

that point. Deflections of the ailerons and spoilers as a function of wheel position are shown in figure 20(b). Roll acceleration for full wheel deflection as a function of airspeed is shown in figure 20(c).

8.1.2 Longitudinal control system- The longitudinal control system is shown schematically in figures 21(a) and 21(b). Longitudinal trim is provided by moving the neutral position of the feel and centering unit. Manual reversion trim is provided by a manually-driven trim tab. A geared balance tab is utilized to reduce pilot loads during manual reversion operation. Predicted pitch response to full elevator deflection vs airspeed is shown in figure 21(c).

8.1.3 Directional control system- The rudder control system is shown schematically in figure 22(a). The double-slotted rudder has a SAS actuator for automatic flight-control inputs. The trim function is implemented through the feel unit neutral position. The predicted yaw acceleration with maximum rudder deflection vs airspeed is shown in figure 22(b).

8.1.4 Flap system- The outboard flaps are conventional double-slotted flaps and primarily develop high lift. They operate through an electric command system from the outboard flap lever in the overhead console. In addition to symmetric operation, the outboard flaps can provide a lateral trim function for engine-out operation by retracting the outboard flap on the side opposite the failed engine. This function is controlled by the pilot through a switch on the windshield center post.

The outboard flap electric command computers also detect asymmetry, and lock the flaps in their present position if the asymmetry exceeds 10° for more than 1 sec, unless that asymmetry is commanded through the lateral trim system.

The trailing-edge flap system is composed of the inboard and center (upper-surface-blown or USB) flaps and the outboard flaps, and is shown schematically in figure 23. The USB flaps are electrically commanded, and operate in unison to provide lift and thrust vector control. Deflections from 0° to 30° are controlled by the position of the USB flap handle on the overhead console, while deflections from 30° to 66° are selected using a thumb switch on the number one throttle lever. The USB flap computers lock the USB flaps in their present position if an asymmetry of more than 10° exists for more than 0.5 sec.

8.1.5 Spoiler system- The spoiler system uses inputs from the speedbrake handle, the pilot's wheel, and the longitudinal SAS computer, which produces a spoiler position as a function of throttle position for direct lift control. These signals are operated on by an electric command computer, which drives the four spoiler panels (two on each wing forward of the outboard flaps) using electro-hydraulic actuators on each panel. The speedbrake function produces symmetric spoiler deployment from 0° to 60° proportional to the speedbrake handle. The roll control function operates by driving the spoilers on the appropriate wing upward to produce a rolling moment to augment the ailerons. Direct lift control (DLC), when selected, positions the spoilers at 13° . When the throttles are advanced, the spoilers drop from that point; when the throttles are retarded, the spoilers move upward. These movements produce a

rapid change in the lift to quicken the flightpath response to throttle changes. The deflections are washed out to the bias position after the initial response. This option is selectable only when the USB flaps are at 30° or more (landing configuration). Computation for mechanization of the DLC function is performed in the longitudinal SAS computer.

8.2 Stability Augmentation System

The QSRA is provided with three axis-stability augmentation with each axis being independent. Principal inputs and outputs are shown in figure 19(a).

The roll and yaw stability augmentation systems provide improved airplane handling qualities resulting in a decrease in pilot workload. Roll-mode and spiral-mode augmentation is provided in the lateral axis, with dutch roll damping and turn coordination provided in the directional axis. In addition, control wheel position information is used in the lateral axis to improve the linearity of the airplane roll response to wheel inputs. An option added to the lateral stability augmentation system after airplane delivery incorporates at the pilot's option a roll rate command/attitude hold system. When the airplane is off the ground, a roll rate is commanded proportional to the wheel position. When the wheel is in detent, the existing roll attitude is maintained. If the roll angle is less than 3°, the system will level the airplane and maintain zero roll angle.

The lateral and directional stability augmentation systems are nonredundant. Failure transients are kept to a minimum by rate and position limiting the electrohydraulic SAS servi actuators.

Pitch augmentation is provided in the form of a rate command/attitude hold system. The pitch augmentation system also provides the DLC function by processing throttle position signals and sending symmetric deflection commands to the spoiler control electronics. The pitch SAS computer is a digital mechanization and drives the elevator through the elevator SAS servo.

8.3 Electric Command System

8.3.1 Spoiler system- The spoiler electric command system is composed of two isolated separate subsystems. The first of these drives the outboard spoilers on each wing; the other drives the inboard spoilers. The spoiler computers have dual signal paths and process the multiple command signals from the pilot's wheel, the spoiler lever, and the pitch SAS computer to drive the two servos. The components of the system are shown schematically in figure 24.

8.3.2 Upper-surface-blown flap system- The electric, USB flap command system consists of two separate and isolated subsystems, one driving the inboard flaps and the other, the center flaps. The computers incorporate single-channel signal processing and dual-channel drive electronics for the two electrohydraulic flap actuators associated with the subsystem. If the position feedback signals disagree by a predetermined amount, a monitor

circuit detects the asymmetry and locks those two servos in their current position. The components of the system are shown schematically in figure 25.

8.3.3 Outboard flap system- The outboard flap system consists of a single system driving the two outboard flaps. The computer mechanization provides single-channel signal processing, from the outboard flap handle and the flap trim switch, with dual-channel servo-drive electronics for the two flaps. Monitoring of symmetry is mechanized as in the USB computers. Figure 26 shows the components of this system.

9. FLIGHT-TEST INSTRUMENTATION SYSTEM

The QSRA is equipped with a high-speed data system comprised of transducers, signal conditioning equipment, a telemetry transmitter, and a tape recorder. This system measures, transmits, and records significant airplane parameters for real-time or after-the-fact analysis.

The FTIS, illustrated in block diagram form in figure 27, operates as follows. Data from the transducers are transmitted to the analog and digital network panels, which provide the necessary signal conditioning. The conditioned data then passes to the remote multiplexer/digitizer units (RMDU), which adjust the gains to a programmed level, provide analog to digital conversion, and encode the data in a pulse-code modulation, serial bit stream. Separate precision low-voltage power supplies located in the analog network panels furnish transducer excitation power where required. The FTIS contains a time code generator which furnishes time correlation for the system, which can be synchronized with ground IRIG time. The data are recorded on a standard 14-track, airborne, magnetic tape recorder. An interface is available for in-flight transmission of data from one RMDU via L-band telemetry to a ground station for real-time data monitoring. A more detailed description of system elements is as follows:

9.1 Sensors and Transducers

Numerous sensors and transducers, such as thermocouples, pressure transducers, strain gauges, servos, potentiometers, accelerometers, etc., are installed on the QSRA to measure parameters of interest.

9.2 Tape Recorder

The tape recorder is an Astro-Science (Bell and Howell) airborne wide-band FM recorder model MARS-144 (LT)-3D. The unit is a 14-track analog recorder, and uses a 10-in. reel of magnetic tape. A PCM data bit stream from each RMDU and the time-code generator output are recorded on separate tracks. The tape recorder is the limiting component in the FTIS due to its bit-packing density limitation as related to amount of tape available, speed of running, and length of record required for flight data recording during test. The

recorder is operated at 7-1/2 in./sec, which allows about 1-1/2 hr of full-time data recording, which will cover one data flight.

9.3 Time-Code Generator

The time-code generator is a Datametrics Model SP-375 Airborne Synchronized Generator, which produces an IRIG B output for recording on the tape recorder. The unit will be synchronized with the ground time-code generator for flight tests and can be synchronized with radio station WWV.

9.4 Active Network Panels

The analog and digital active network panels process the transducer signals to make them compatible with the RMDU's. They also contain a Tecnetics power supply module, which provides ± 5 V d.c. for transducer excitation.

9.5 Parameter List

The FTIS currently records the parameters listed in tables 1 and 2. There is limited capability to add additional parameters if required, for specific experiments.

10. OPERATIONAL SUBSYSTEMS

10.1 Fuel System

The QSRA fuel system is diagrammed in figure 28. It is comprised of two fuel tanks contained in the wing from which four fuel boost pumps feed two fuel manifolds, one for each pair of left-hand and right-hand engines. The engines can also function on engine-driven fuel pumps using suction feed. Fuel levels between the left and right tanks can be balanced by shutting off the boost pumps on the side with more fuel remaining. Each tank holds 5,100 lb of JP-5 or Jet-A fuel, and is vented to the atmosphere.

The airplane can be fueled either by conventional pressure fueling or by over-the-wing gravity filler ports. For pressure fueling, automatic float-operated shut-off valves are provided. Defueling can be accomplished using the suction capability of ground fueling equipment.

10.2 Hydraulic System

The QSRA hydraulic system is shown schematically in figure 29. Hydraulic power is supplied by three separate and isolated hydraulic systems at 3000 psi. Systems A and B are each pressurized by two engine-driven pumps. The system A

pumps are driven by engines 1 and 2, and the system B pumps are driven by engines 3 and 4. System C is pressurized by an a.c. motor-driven pump run full time. System fluid is MIL-H-5606.

The A and B systems are configured so that their power demands are approximately equal in size. One pump, driving system A or B, will meet all the system requirements of the given system should a single associated engine or pump failure occur. System C drives the aileron actuators only.

All primary control surface actuators are of a dual tandem configuration, and each actuator is supplied from two different power systems. Thus, normal surface actuation rates can be maintained in the event a single power system loss occurs. In the event of a double system failure, lateral control is maintained since the aileron actuators are powered from systems A, B, and C.

10.3 Electrical System

The QSRA electrical system is shown schematically in figure 30. Four 15 KVA, 115 V, 400 Hz generators are driven by the engines through constant speed drives. The two left generators are connected together to form one system; the two right generators provide a separate system. Automatic power transfer allows one generator to pick up the entire load for each system in the event of a generator or engine failure. Transformers on each generator provide 26 V a.c. power. Two transformer/rectifier units give 28 V d.c. power. Manually-controlled bus-tie relays transfer all power between left and right 115 V a.c. systems if both generators in one system should fail.

10.4 Environmental Control System

The environmental control system (ECS) for the QSRA is shown schematically in figure 31. This system provides heating, cooling, and ventilation to the flight deck and rear cabin. Engine bleed air, precooled by fan flow, or ground-start cart air is supplied to an air-conditioning pack which provides cooled air. This conditioned air and/or ram air from a scoop on the airplane nose is mixed with engine bleed air to provide the desired temperature in the crew areas. The percentage of air diverted to the aft cabin is controlled by a manual valve. The air to the flight deck is run through a muffler to reduce noise. The system is capable of holding temperatures in the cockpit to 80° F on a hot day.

10.5 Communications and Navigation Systems

The QSRA has one UHF and one VHF transceiver for communications. The following navigation and guidance systems are provided:

Automatic direction finder	(1)	Tacan	(1)
VOR receiver	(2)	Radar transponder	(1)
Marker beacon/glideslope receiver	(1)	J-2 compass	(1)

10.6 Crew Station

10.6.1 Cockpit arrangement- The QSRA has side-by-side seats for a pilot and copilot. The seats are not ejection seats and crew emergency egress is described in section 10.7. The airplane may be flown from either seat but operation of the longitudinal SAS and some displays make the left seat preferable. In addition to the instrument panel, there is a center console and an overhead console.

10.6.2 Instrument panel- The instrument panel is shown in figure 32(a), and contains the following:

Attitude indicators	(2)	Oil pressure and temperature indicators	(4)
Angle-of-attack indicators	(2)	Fuel flow indicators	(4)
Sideslip angle indicator		BLC pressure indicators	(4)
Airspeed indicators	(3)	Flap position indicators	
Course selectors	(2)	Outboard	
Turn and slip indicators	(2)	USB center	
Vertical speed indicators	(2)	USB inboard	
Barometric altimeters	(2)	d.c. meters	
Normal acceleration indicator		a.c. meters	
Tacan indicator		Surface position indicator	
Radar altimeters indicator		(aileron, rudder, spoilers)	
Battery temperature monitor		Surface position indicator	
Brake pressure indicator		(elevator)	
Hydraulic pressure indicators	(2)	Annunciator Panel (60 positions)	
Hydraulic quantity indicators	(2)	Master caution lights	(2)
Fan speed indicators	(4)	Master fire warning lights	(2)
Core speed indicators	(4)	Miscellaneous controls, switches	
Mixed gas temperature indicators	(4)		

10.6.3 Overhead console and eyebrow panel- The overhead console is shown in figure 32(b) and contains the following:

Fire switches	(4)	Lighting control panel
Flap levers (USB and outboard)	(2)	Hydraulic control panel
Speed brake lever		ECS panel
Thrust levers		Bleed air and ice-control panel
Gust lock lever		

The eyebrow panel above the windshield contains:

Rudder trim switches	(2)
Elevator trim cutout switches	(2)
Rudder trim position indicator	

10.6.4 Center console- The center console (aisle stand) is shown in figure 32(c) and contains the following control panels:

IFF
ADF
VHF communications
VHF (VOR/ILS)
Tacan
Stability augmentation system

Interphone
Antiskid
Marker/beacon glideslope
Flight-test instrumentation
VHF communications

(2)

10.7 Emergency Egress

The QSRA is provided with seven escape doors or hatches, the locations of which are shown in figure 33. The normal entrance/exit ladder under the aft fuselage can be used for bailout. The primary bailout exit is through the jettisonable hatch in the cockpit floor. Ground exit is possible through the pilot's and copilot's jettisonable side windows or the pilot's overhead escape hatch. Emergency exit hand slides are provided on the left and right sides of the cockpit. Side cabin escape hatches are also available.

11. GROUND SERVICING AND HANDLING

11.1 Ground Service Equipment

In order to operate the QSRA, the following facilities are needed:

1. Ground electrical cart (type MD-3A or equivalent) - This unit furnishes 115 V a.c. (45 kW) and 28 V d.c. (60 kW) for airplane ground operations. It is required for fueling the airplane if the fuel quantity indicators are to function.
2. Hydraulic-system test stand - This unit furnishes 25 gal/min, 3,000 psi hydraulic power for system preflight. Two units are required if the A and B hydraulic systems are to be preflighted simultaneously.
3. Ground air supply (start cart) - The aircraft requires 30 psi in the starter duct to start the first engine. Cross starting is possible after one engine is running, but this is not standard practice.

11.2 Fluid Requirements

Fuel MIL-T-5624, grade JP-5
or jet A per ASTM D1655

Oil Engine and auxiliary gearbox
MIL-L-23699, Mobil Jet II

Hydraulic fluid MIL-H-5606

11.3 Airplane Grounding

The QSRA airplane must be grounded to earth during any ground service operation using the grounding jacks provided. For refueling, these jacks are located adjacent to both the single-point fueling station and the over-wing filler ports.

11.4 Servicing

Trained aircraft-service personnel will perform all maintenance, modifications, and inspections required for the flight research program. Appropriate maintenance and inspection manuals will be available and used as reference material in performing this work. Complete up-to-date drawings (two sets) will be maintained in a location convenient to the airplane.

12. DOCUMENTATION LIST

Documents pertaining to the QSRA developed in support of contract NAS2-9081 are listed below. Distribution of these documents is controlled by the NASA Ames Research Center Quiet Short-Haul Aircraft Office.

<u>Document</u>	<u>Number</u>
Configuration Definition	D6-42487
QSRA Maintenance Manual	D340-14401
QSRA Operations Manual	D340-13801
QSRA Predicted Performance	D340-10100
Predicted Flight Characteristics	D340-10500
QSRA Phase II Flight Simulation Mathematical Model	NASA CR-152197

TABLE 1.- FLIGHT-TEST INSTRUMENTATION PARAMETERS - RMDU/A

Parameter	Number or measurements	Comments
Airplane environment		
Acceleration - C.G.	3	Lateral, longitudinal, normal
Flightpath angles	3	Pitch, roll, heading
Angle of attack	1	Nose boom
Sideslip	1	Nose boom
Altitude	2	Nose boom, radio
Airspeed	2	Nose boom, J-TEK
Altitude rate	1	Radio altimeter
Total temperature	1	
Angular rates	3	Pitch, roll, yaw
Wing vertical acceleration	2	Left wing, front and rear spar
Accelerations, stabilizer	3	Left tip chordwise, left front spar and right front spar vertical
Accelerations, vertical stabilizer	3	Lateral: Fin tip forward and rear, midspan
Primary flight controls		
Control forces	3	Column (stick), pedal, wheel
Control positions	3	Column (stick), pedal, wheel
Surface positions	4	Elevator, aileron (2), rudder
Spoiler position	4	Left and right inboard, outboard
Flap positions	6	2 USB inboard, 2 USB center, 2 outboard
Trim actuator position	2	Elevator, rudder
Automatic flight controls		
Servo command	3	Pitch, roll, yaw
SAS actuator position	3	Pitch, roll, yaw
Fuel system		
Totalizer	4	Fuel used, engines 1, 2, 3, 4
Fuel temperature	4	Engines 1, 2, 3, 4
Fuel flow	4	Engines 1, 2, 3, 4
Propulsion		
Fan speed (N_1)	4	Engines 1, 2, 3, 4
Core speed (N_1)	4	Engines 1, 2, 3, 4
Total pressure (5.4)	4	Engines 1, 2, 3, 4
Total pressure fan exit	4	Engines 1, 2, 3, 4
Total pressure fan exit	4	Engine 2, circumferential
Fuel pressure, inlet	4	Engines 1, 2, 3, 4
Total temp. IGT (4.1)	4	Engines 1, 2, 3, 4; double precision
Power lever angle	4	Engines 1, 2, 3, 4

TABLE 1.- CONCLUDED.

Parameter	Number or measurements	Comments
Boundary-layer control system		
Calibration duct dynamic pressure	4	Engines 1, 2, 3, 4
Calibration duct static pressure	4	Engines 1, 2, 3, 4
Static pressure in duct. Refer to copilot's static pressure	4	2 LE, 2 aileron
Static pressure - BLC duct	4	LH and RH glove and between nacelle
BLC duct total temperature	4	Engines 1, 2, 3, 4
Miscellaneous		
Landing gear oleos	3	Right and left main, nose
Event marker	1	Pilot's wheel
Time - IRIG B	1	

TABLE 2.- FLIGHT-TEST INSTRUMENTATION PARAMETERS - RMDU/B

Parameter	Number of measurements	Comments
Airplane environment		
Acceleration, pilot's seat	2	Normal, lateral
Acceleration, aft body	2	Vertical, lateral
Temperature, wing rear spar	1	Aft of engine no. 3
Temperature, heat shield	1	Aft of engine no. 3
Temperature, wing skin	1	Aft of engine no. 3
Temperature, trailing-edge panel	3	Wing station 105, 110, 115
Flight controls		
Flap position	6	All surfaces
Spoiler position	4	All surfaces
Flap actuator pressure feedback	6	
Flap handle position	2	Outboard, USB
Column force (CAS)	1	To SAS
Speedbrake handle position	1	
Wheel position (CAS)	1	
Lateral flight-control actuator pressure	1	
Hydraulic system		
Hydraulic pressure	2	Systems A and B
Pump pressure	2	Engines 1 and 2
Suction pressure	1	System A
Case drain temperature	1	System C
Propulsion		
Throttle positions	4	Engines 1, 2, 3, 4
Miscellaneous		
Fuel tank pressure	1	
ECS bleed air pressure	1	
USB beep switch	2	Retract/extend - discrete
USB flap handle 100°	1	
USB flap handle not 0	1	
Outboard flap handle not 0	1	
DLC selected	1	
Elevator out of trim	1	
Throttle lever 81%	4	Engines 1, 2, 3, 4

Page Intentionally Left Blank

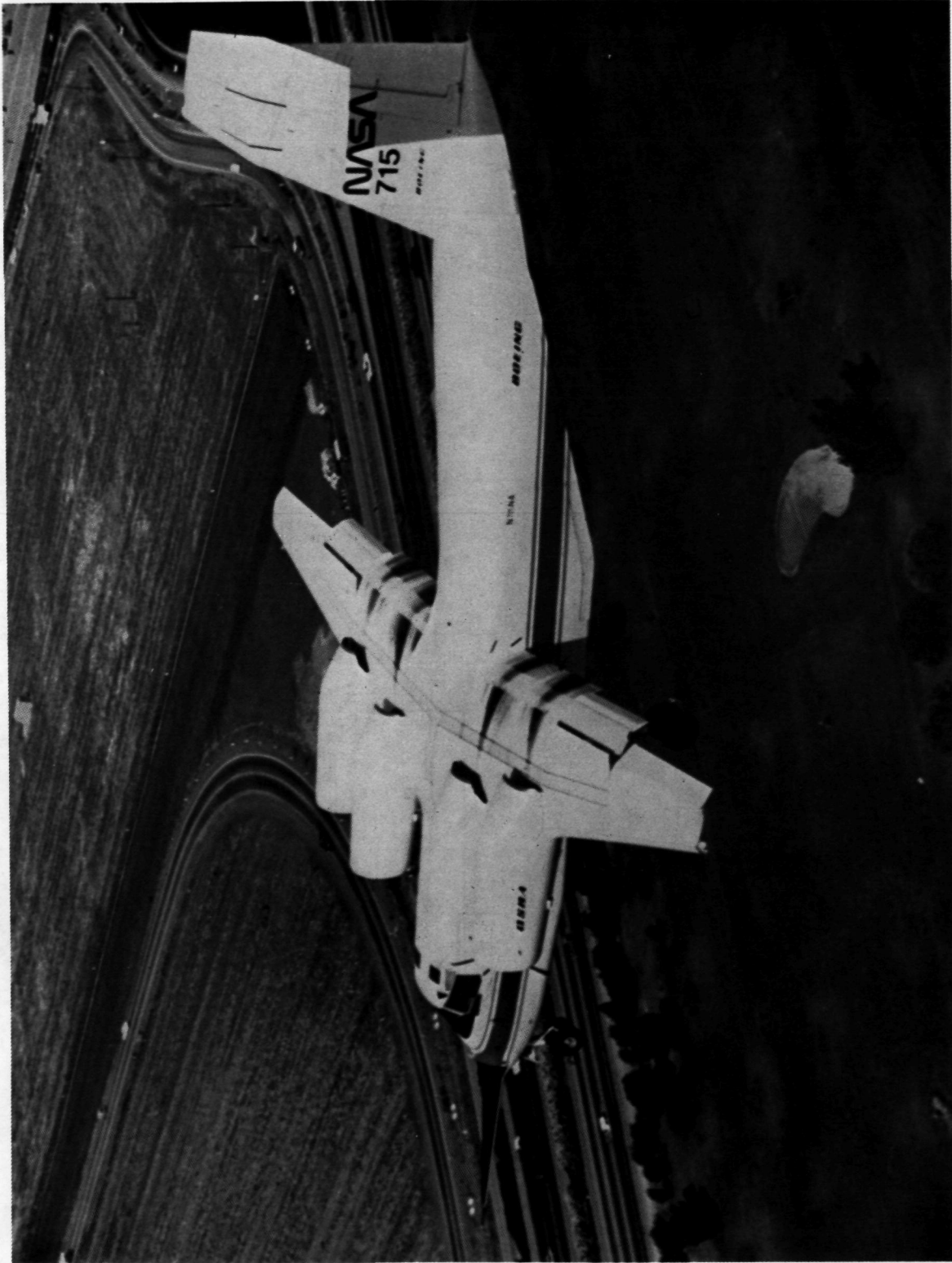
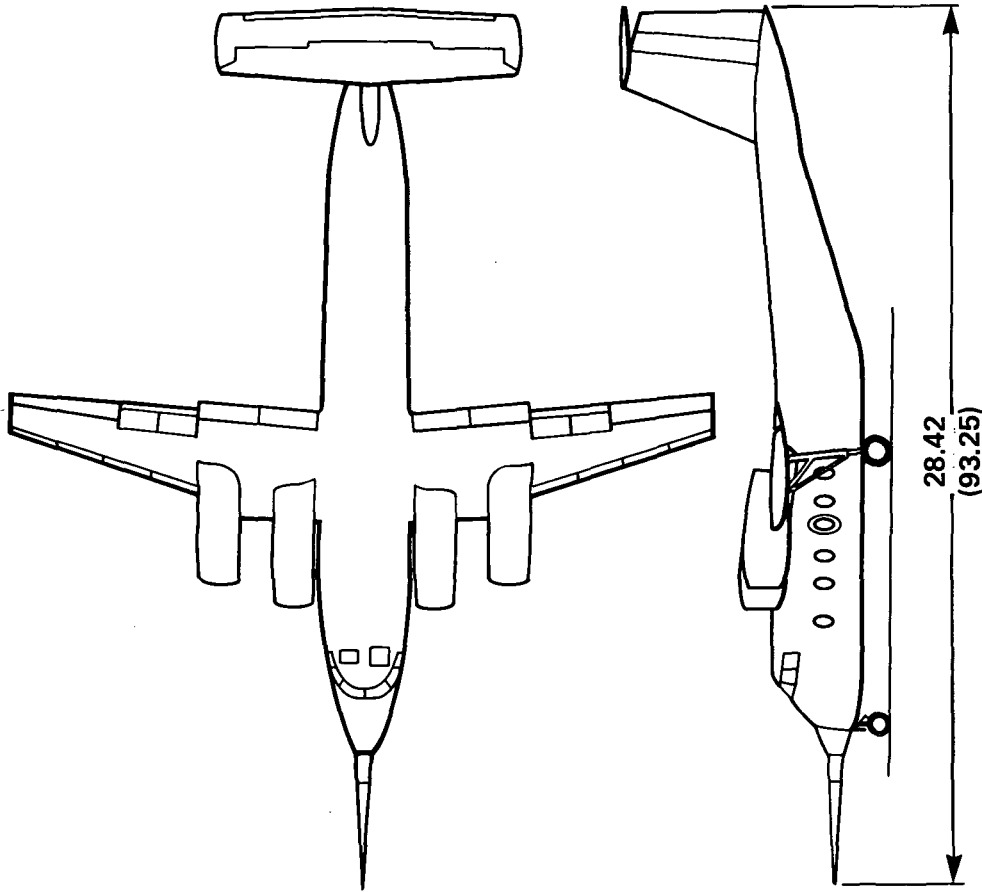

Figure 1.- Quiet Short-Haul Research Aircraft.



TOGW, lb	50,000	222,260 N
WING AREA, ft ²	600	55.74 m ²
WING LOADING, lb/ft ²	83	39.87.4 N/m ²
ASPECT RATIO	9	
THRUST/WEIGHT	.60	

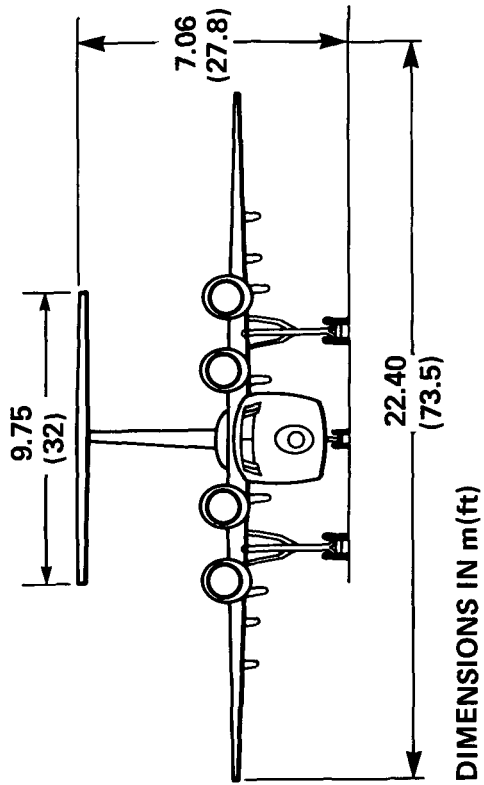
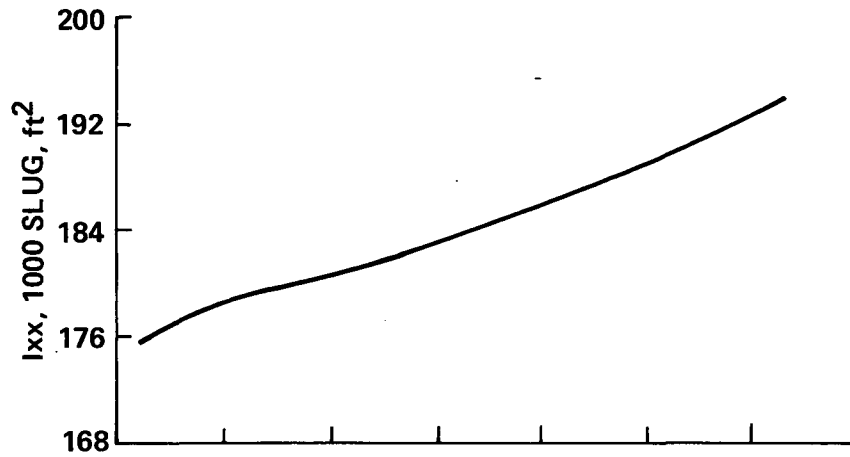
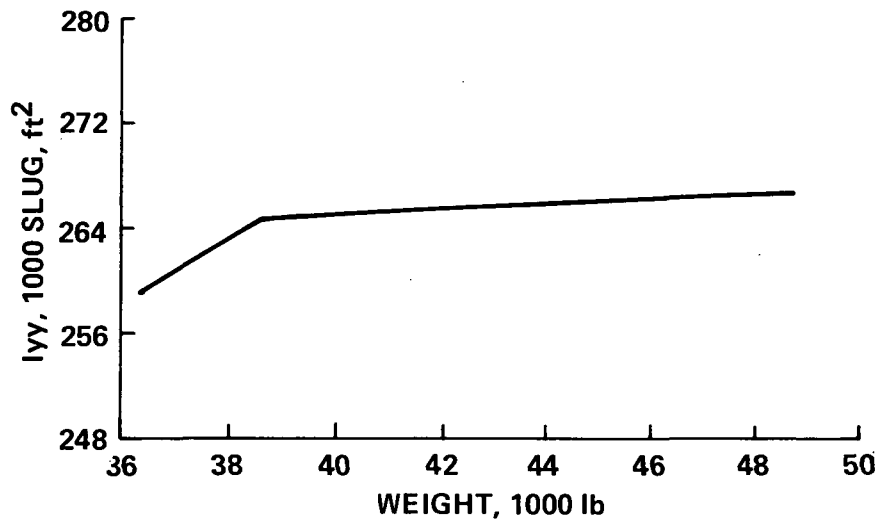

Figure 2.- Quiet Short-Haul Research Aircraft - general arrangement.



(a) Roll inertia.



(b) Pitch inertia.

Figure 3.- QSRA - Variation of inertias with gross weight.

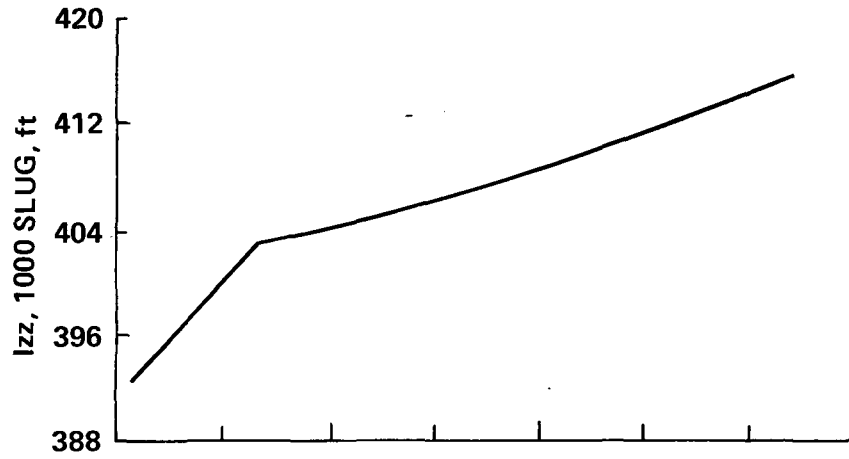

(c) Yaw inertia.

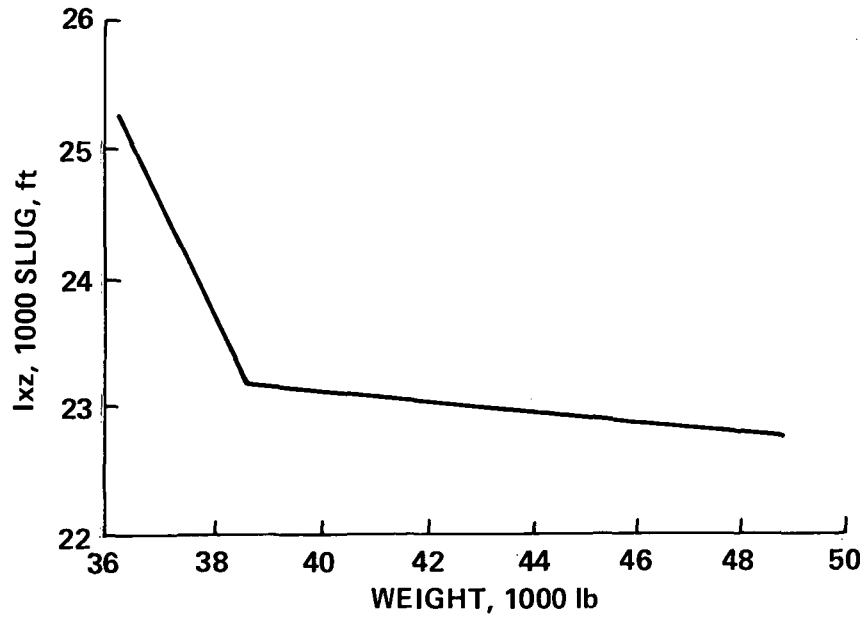

(d) Product of inertia.

Figure 3.- Concluded.

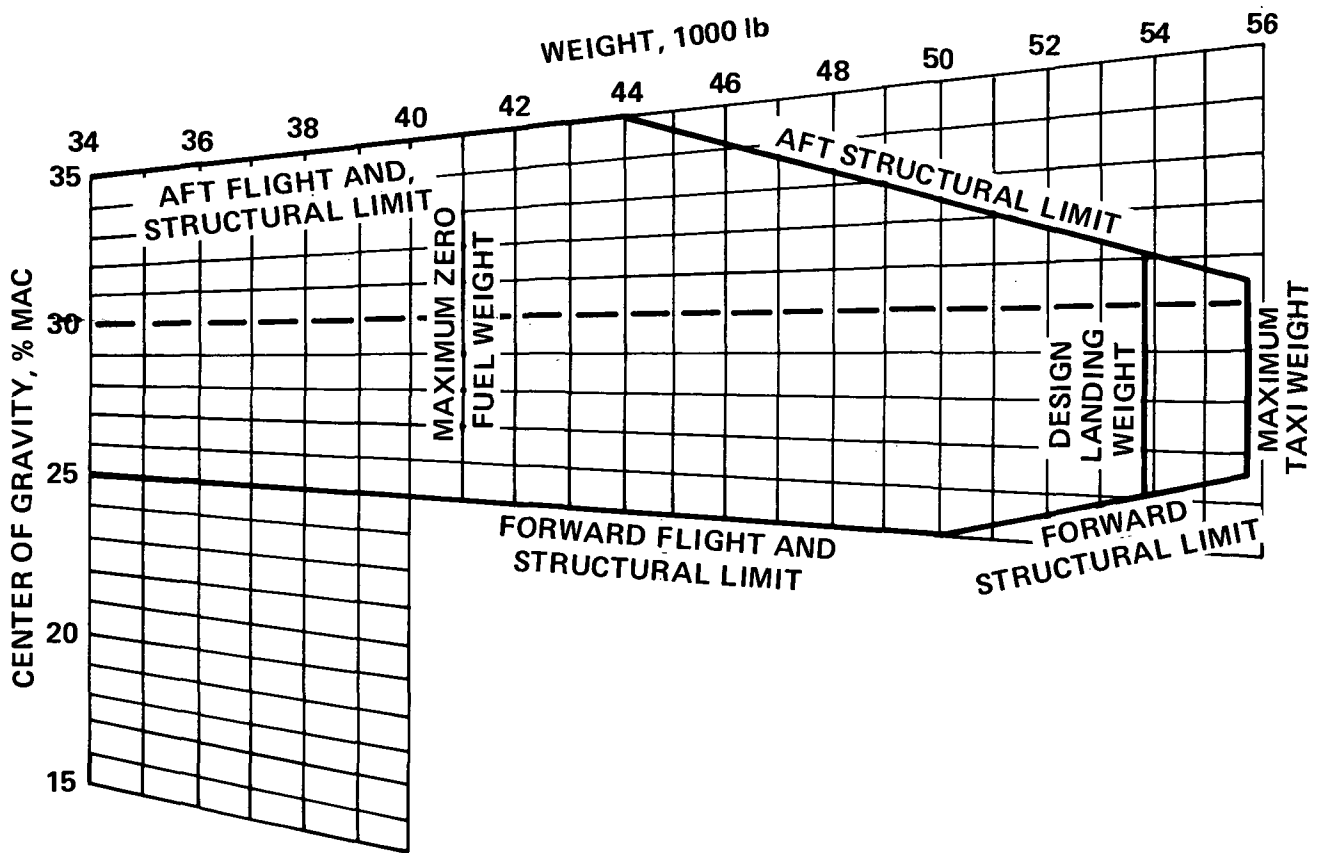
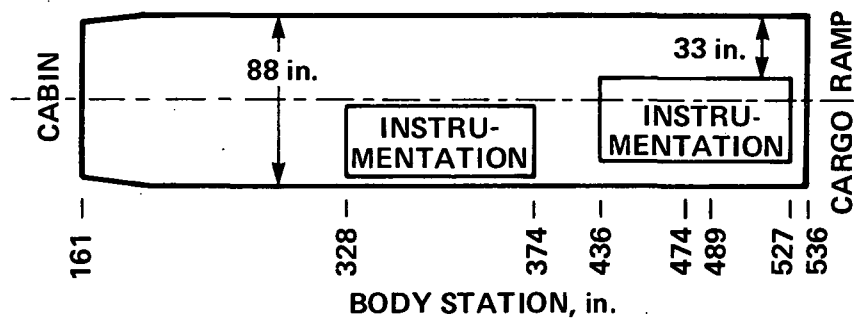

Figure 4.- Center-of-gravity range.



APPROXIMATE LOCATION OF CENTER OF GRAVITY:
 B.S. 370 TO 375
 OVERHEAD CLEARANCE 50 in.

Figure 5.- QSRA main cabin.

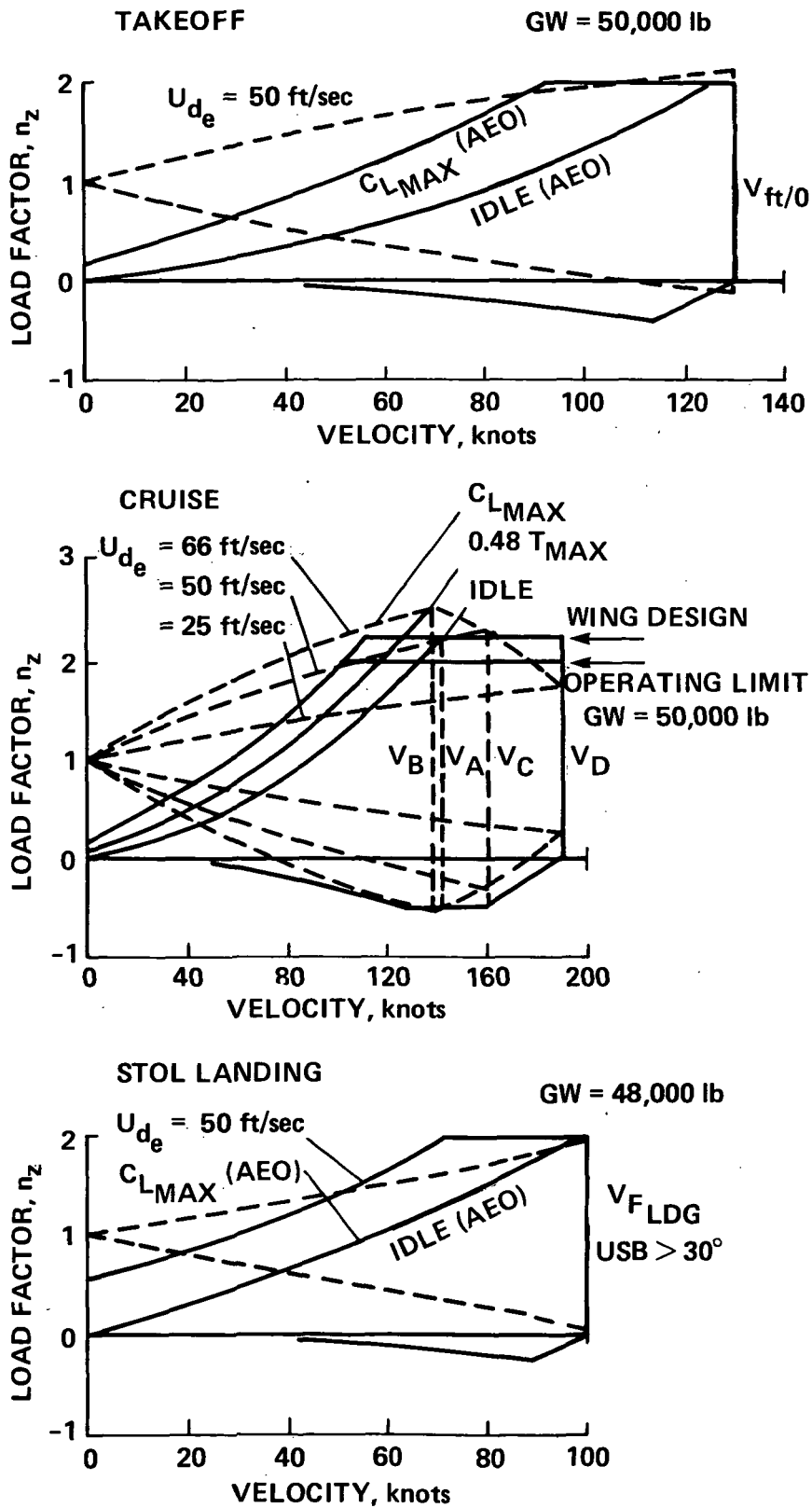

Figure 6.- QSRA V-n diagrams.

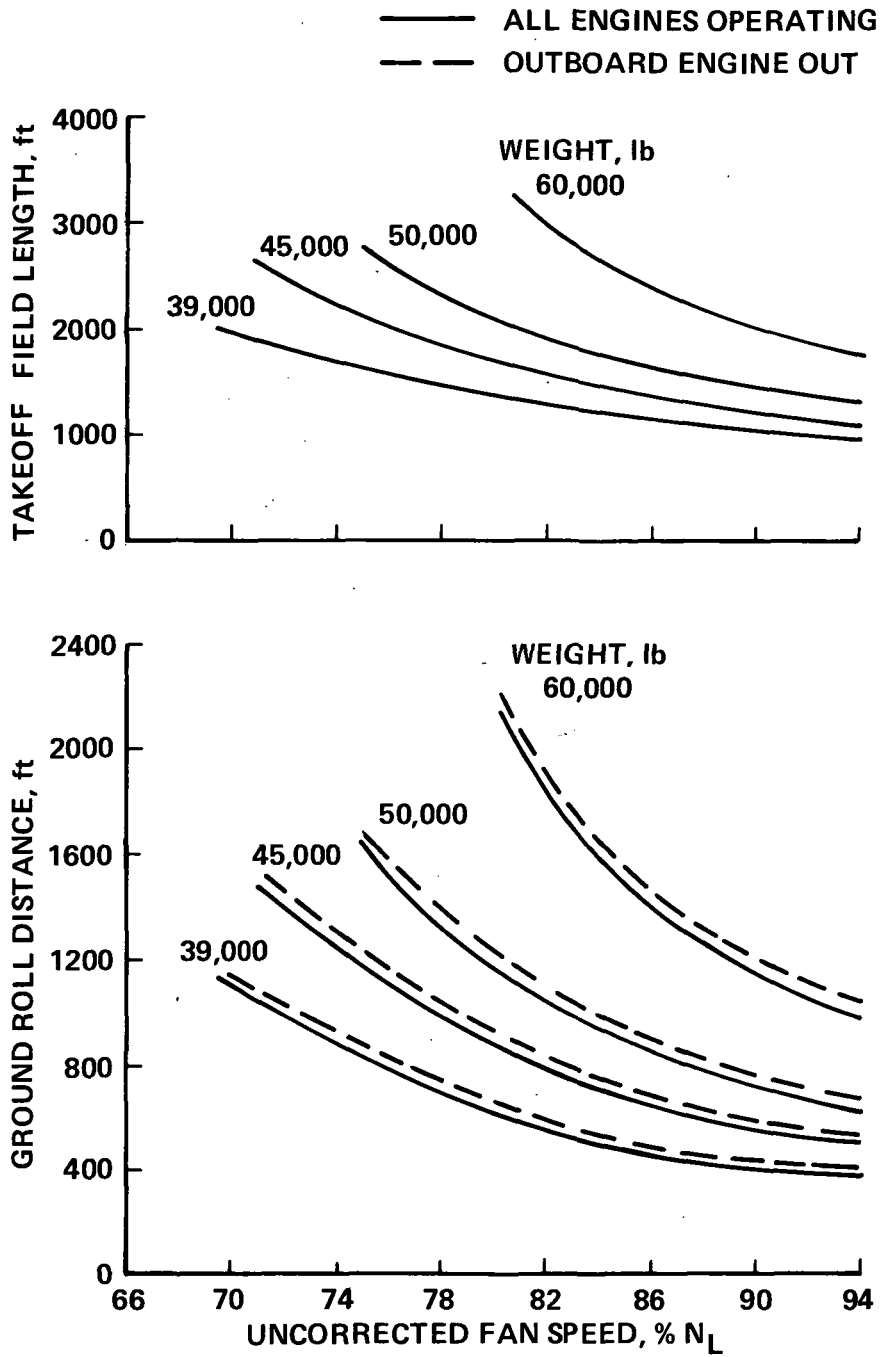
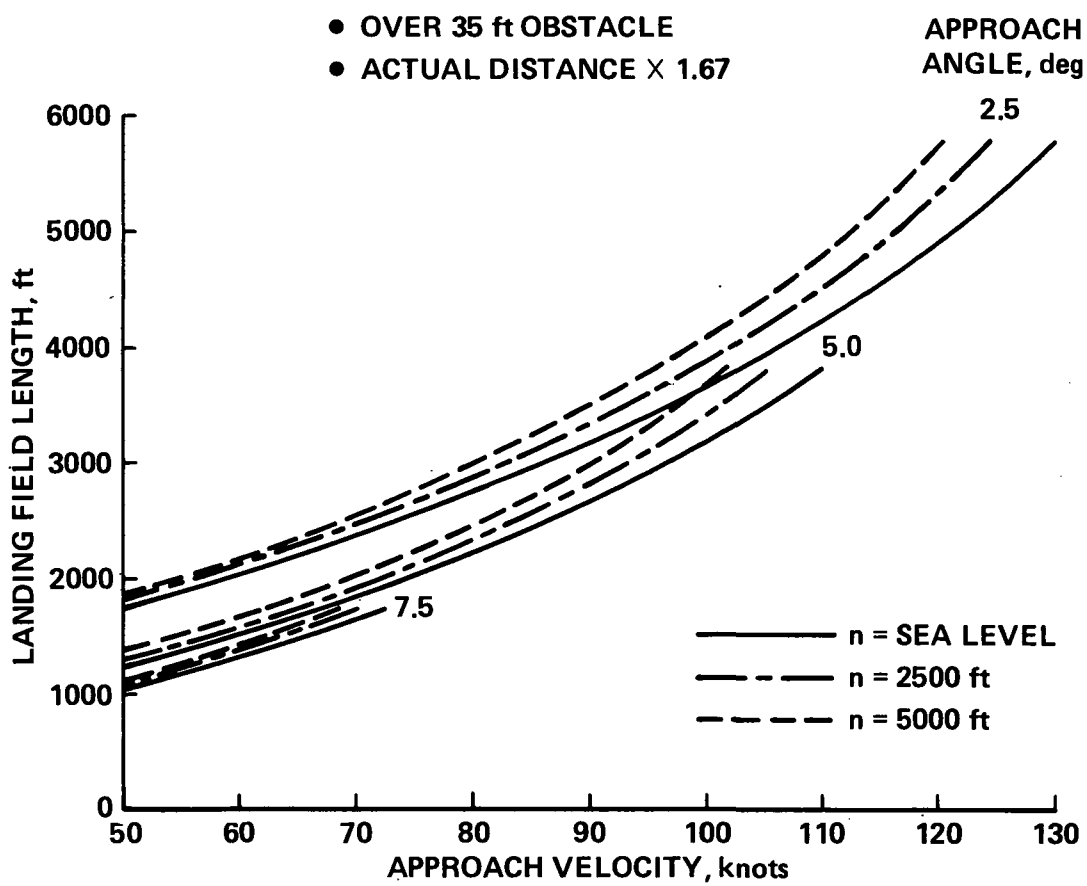
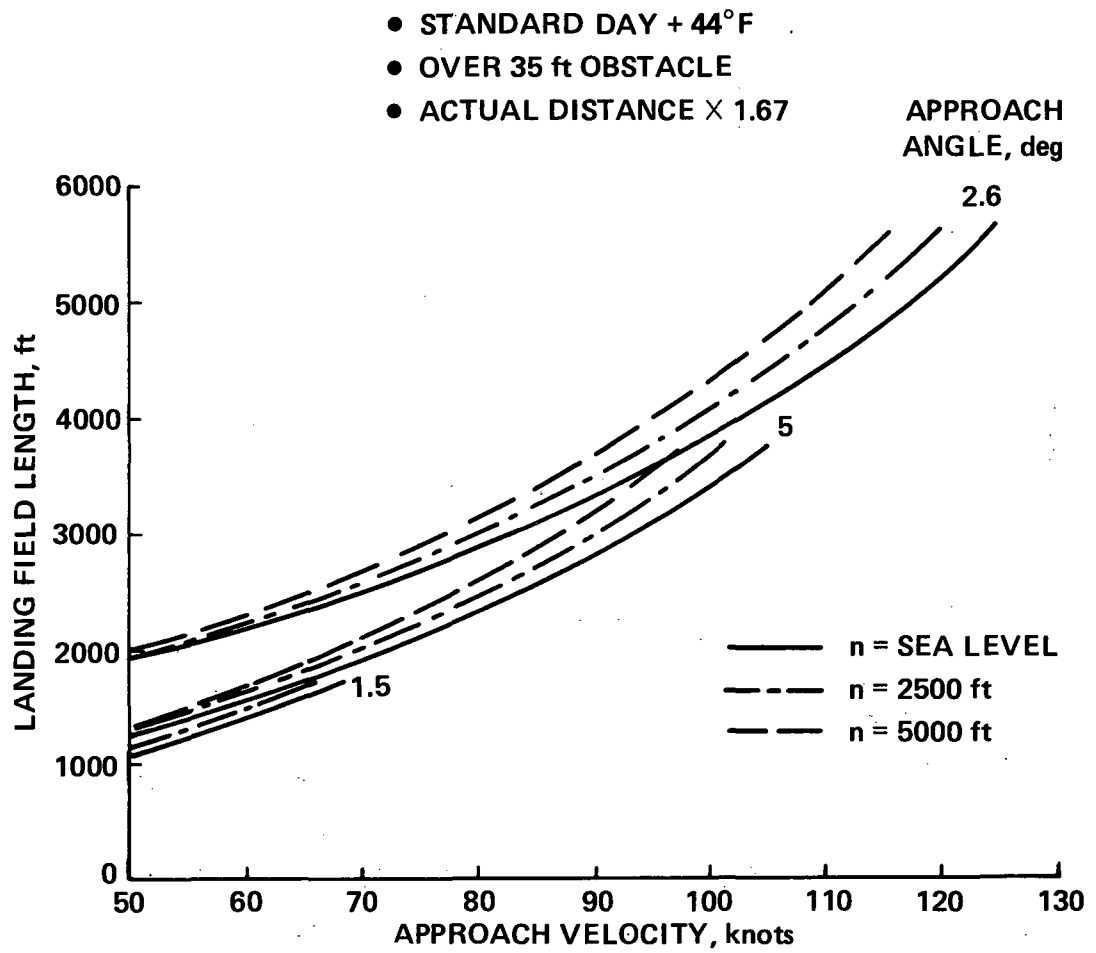

Figure 7.- Takeoff performance (outboard flaps at 59°, USB flaps 0°).



(a) Standard day.

Figure 8.- Landing performance.



(b) Hot day.

Figure 8.- Continued.

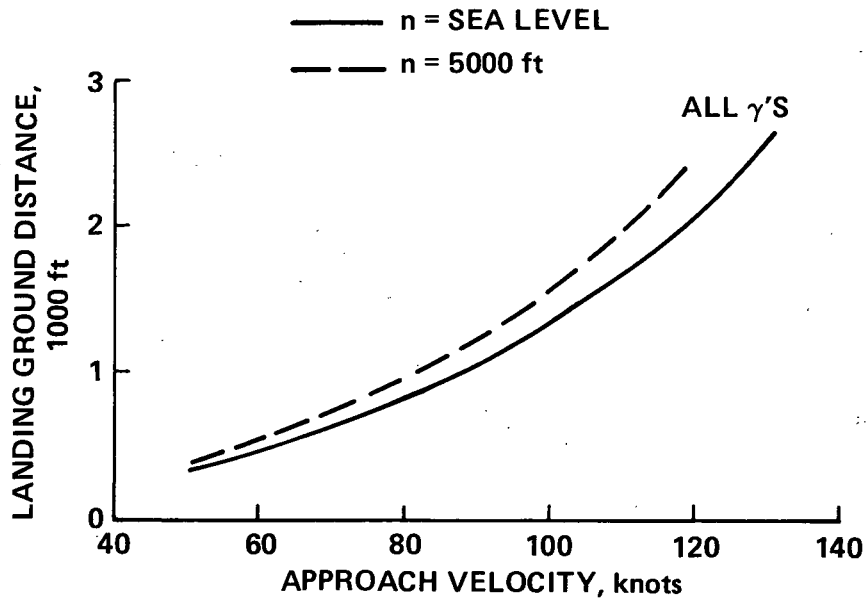
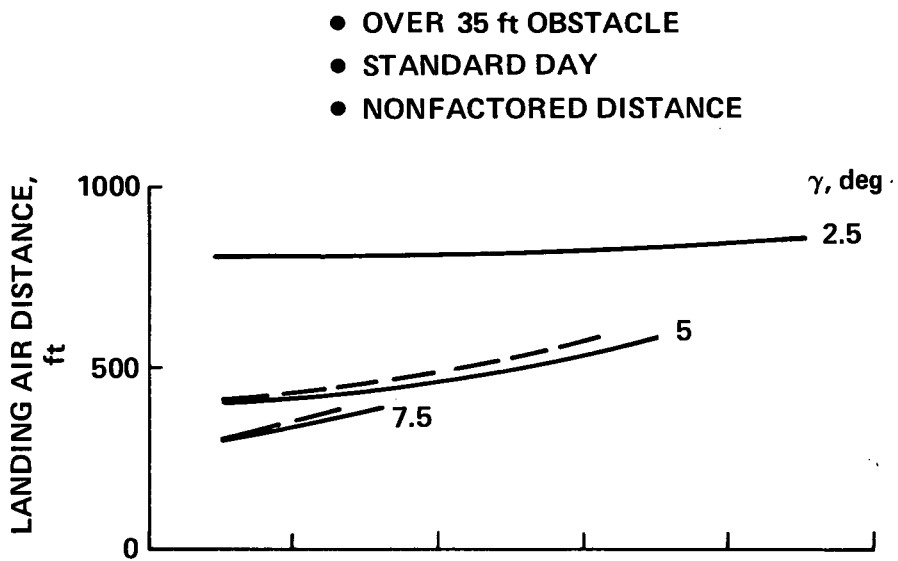

(c) Landing distances.

Figure 8.- Concluded.

- CRUISE CONFIGURATION
 - STANDARD DAY
 - BLC SWITCHES OFF
- V = 130 KEAS, 88% N_L

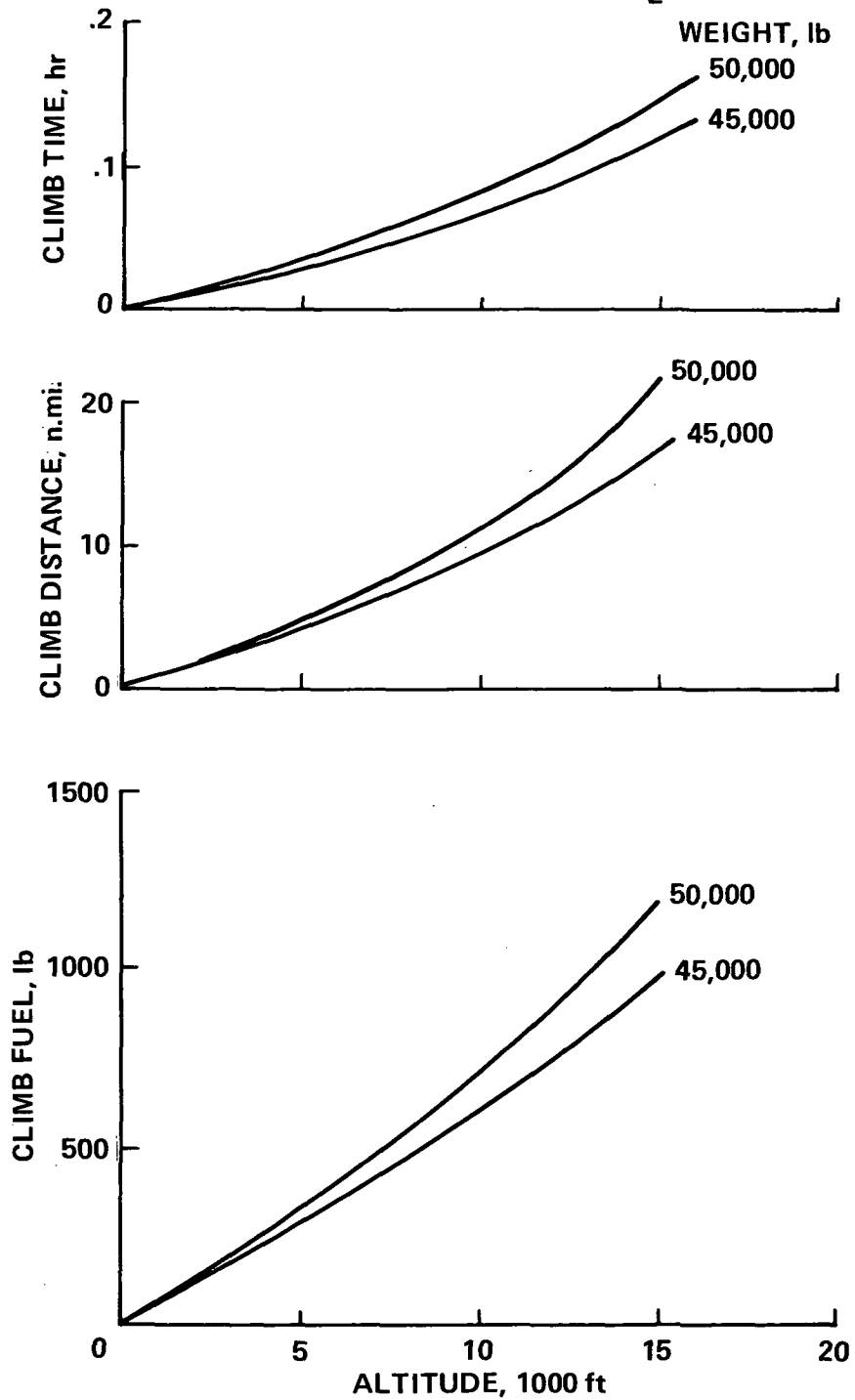

(a) Time, distance, and fuel used.

Figure 9.- Climb performance.

FLAPS RETRACTED - BLC SWITCHES OFF
 $V_{CL} = 130$ knots

— SEA LEVEL STANDARD DAY
 - - SEA LEVEL HOT DAY (+44° F)

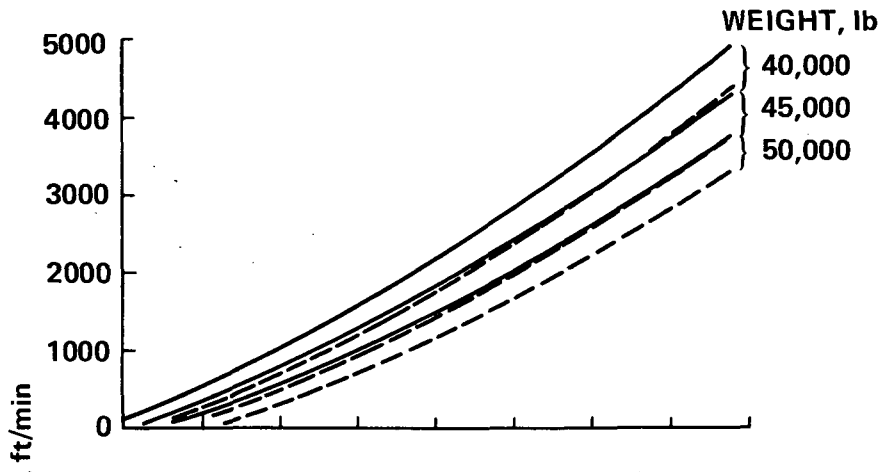

(b) Rate of climb - sea level.

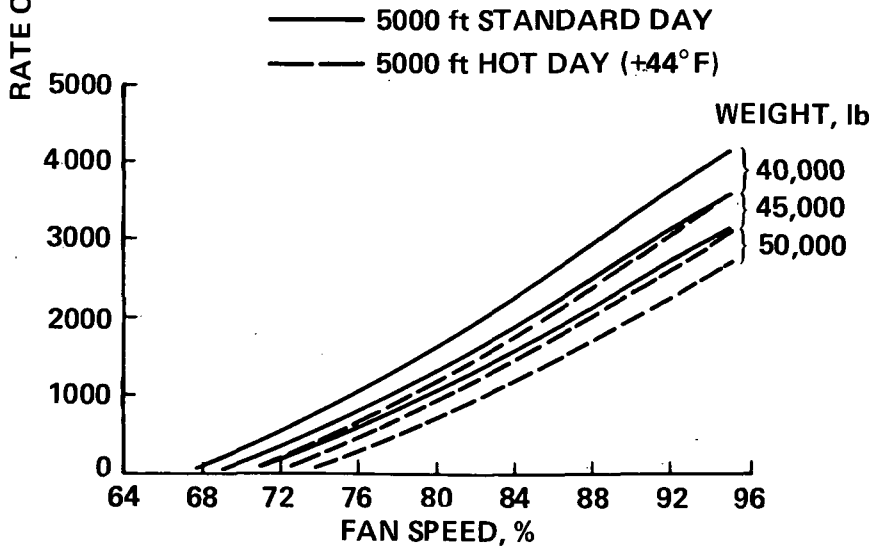

(c) Rate of climb - 5,000 ft.

Figure 9.- Continued.

FLAPS RETRACTED – BLC SWITCHES OFF
 $V_{CL} = 130$ knots

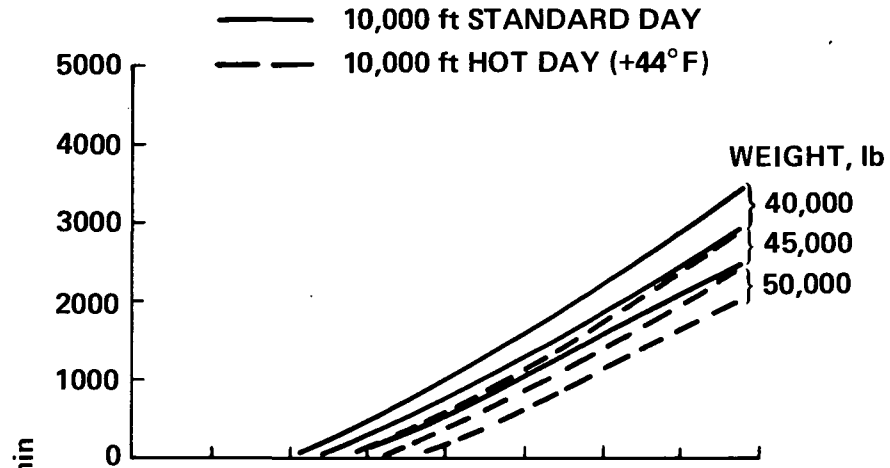

(d) Rate of climb - 10,000 ft.

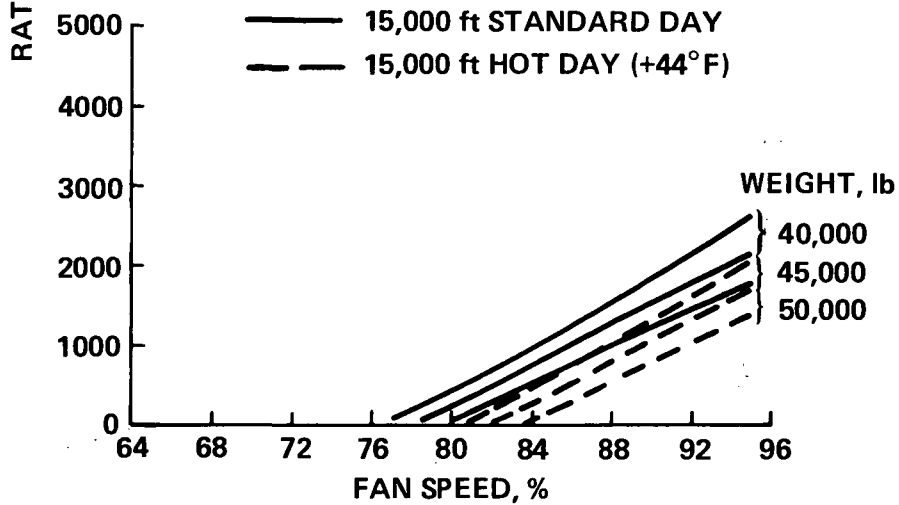

(e) Rate of climb - 15,000 ft.

Figure 9.- Concluded.

V = 130 knots
N_L = 50%
STANDARD DAY
W = 50,000 lb

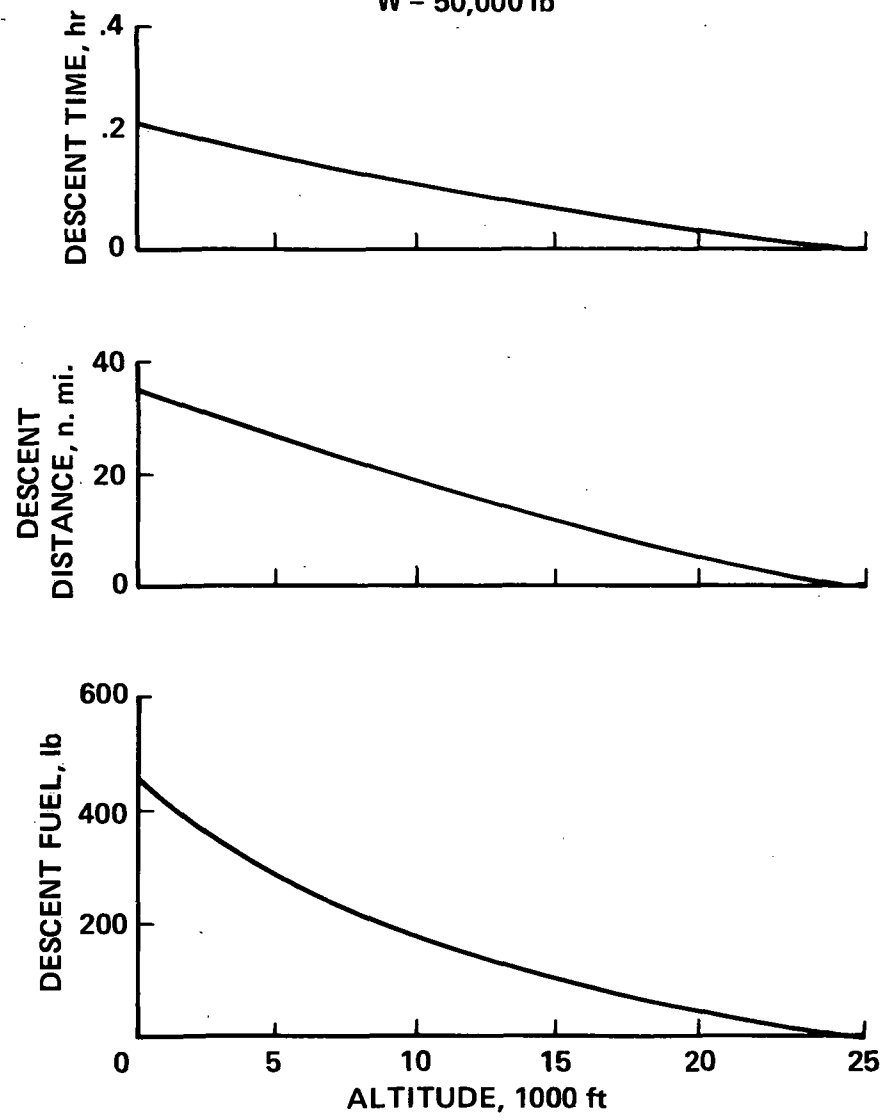
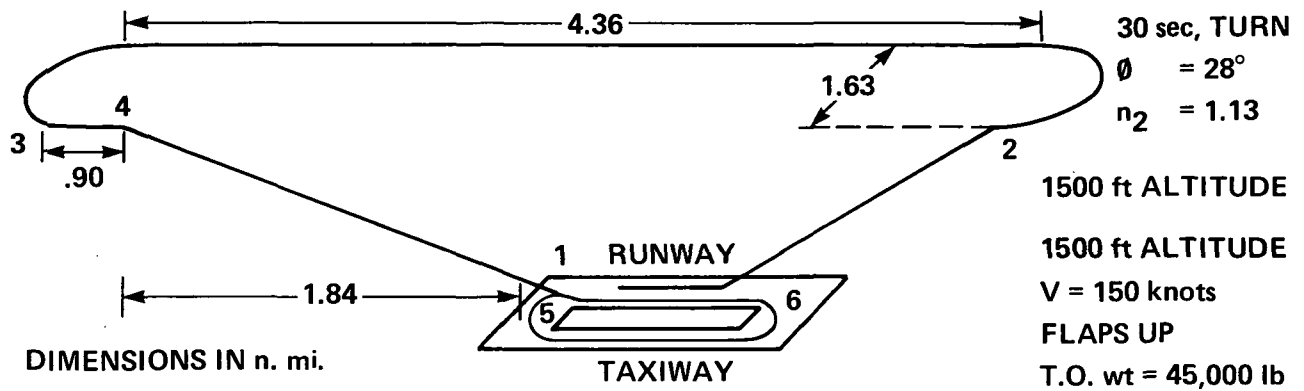

Figure 10.- QSRA descent capability.



	<u>MISSION PROFILE</u>	<u>THRUST</u>	<u>TIME, min</u>	<u>FUEL USED, lb</u>
1 TO 2	TAKEOFF, CLIMB TO 1500 ft ALTITUDE, ACCELERATE TO 150 knots, FLAPS UP	100% F_{GMAX}	0.75	150
2 TO 3	FLY PATTERN TO FINAL APPROACH AT 1500 ft ALTITUDE AND 150 knots	48% F_{GMAX}	2.7	248
3 TO 4	DECELERATE TO 65.5 knots LOWER FLAPS TO $\delta_{USB} = 60^\circ$	30% F_{GMAX}	0.50	33
4 TO 5	APPROACH @ $\gamma = -7.5^\circ$, $C_{LAPP} = 5.5$ AND LAND	43% F_{GMAX}	1.8	163
5 TO 6	ROLLOUT AND TAXI BACK	IDLE	2.2	93
			<u>7.95</u>	<u>687</u>

Figure 11.- STOL mission cycle.

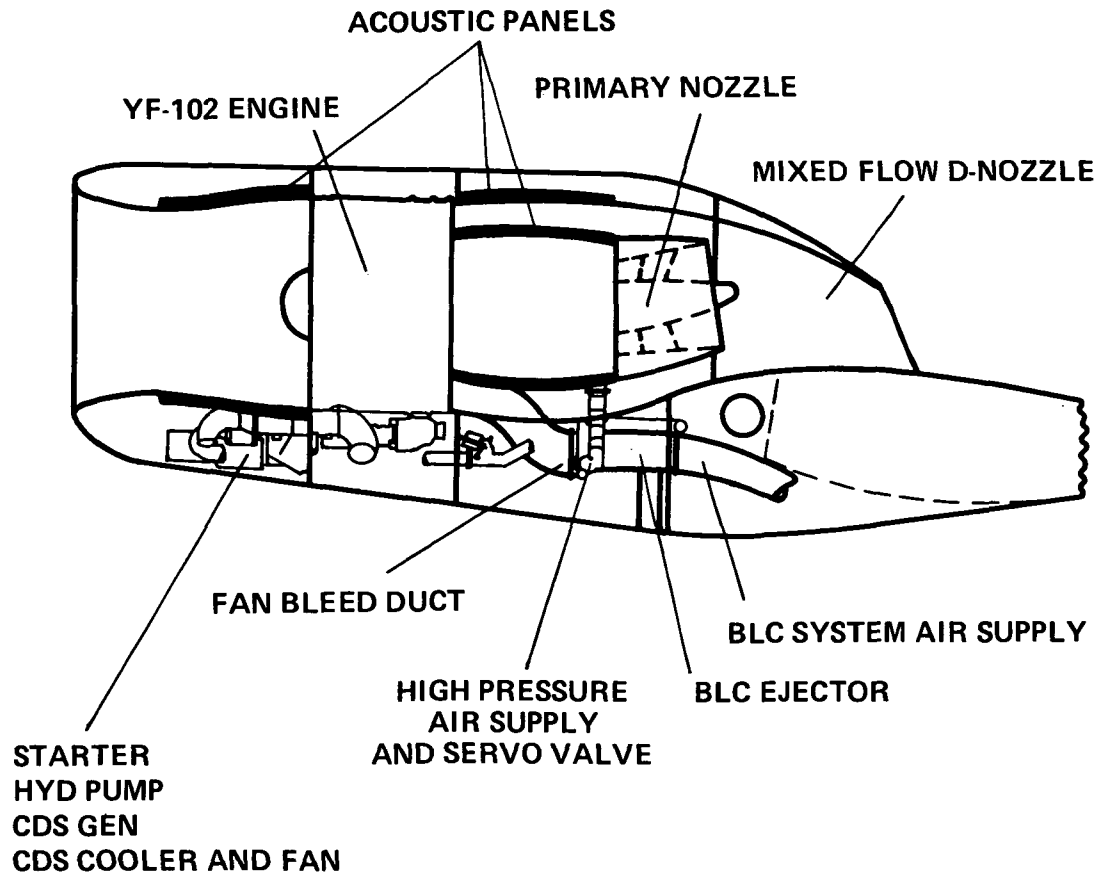
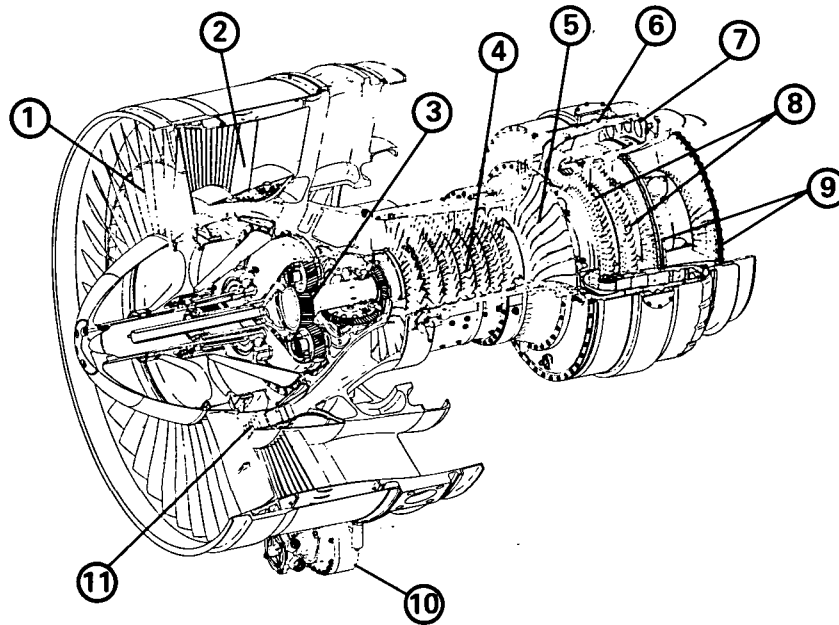

Figure 12.- Engine installation.



- | | |
|--------------------------------|--------------------------|
| 1. FAN STAGE | 6. CUSTOMER BLEED PORTS |
| 2. FAN STATOR | 7. COMBUSTOR |
| 3. REDUCTION GEAR ASSEMBLY | 8. GAS PRODUCER TURBINES |
| 4. CORE AXIAL COMPRESSOR | 9. POWER TURBINES |
| 5. CORE CENTRIFUGAL COMPRESSOR | 10. ACCESSORY GEARBOX |
| | 11. SUPERCHARGER |

(a) Cutaway.

Figure 13.- QSRA engine.

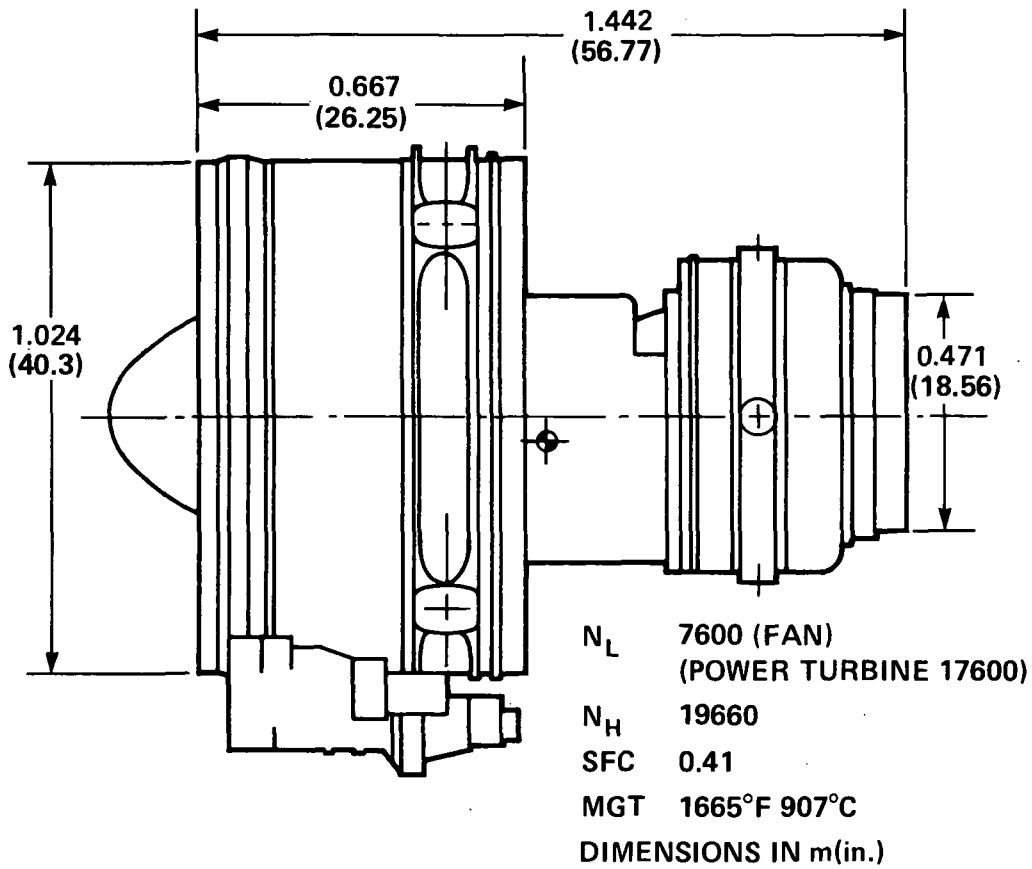

MAX. THRUST	7500 lb	33409.1 N
WEIGHT DRY	1215 lb	551.1 kg
TOTAL AIRFLOW	267 lb/sec	121.1 kg/sec
CORE AIRFLOW	37 lb/sec	16.8 kg/sec
B.P.R.	6.2	

(b) Geometry and uninstalled thrust.

Figure 13.- Concluded.

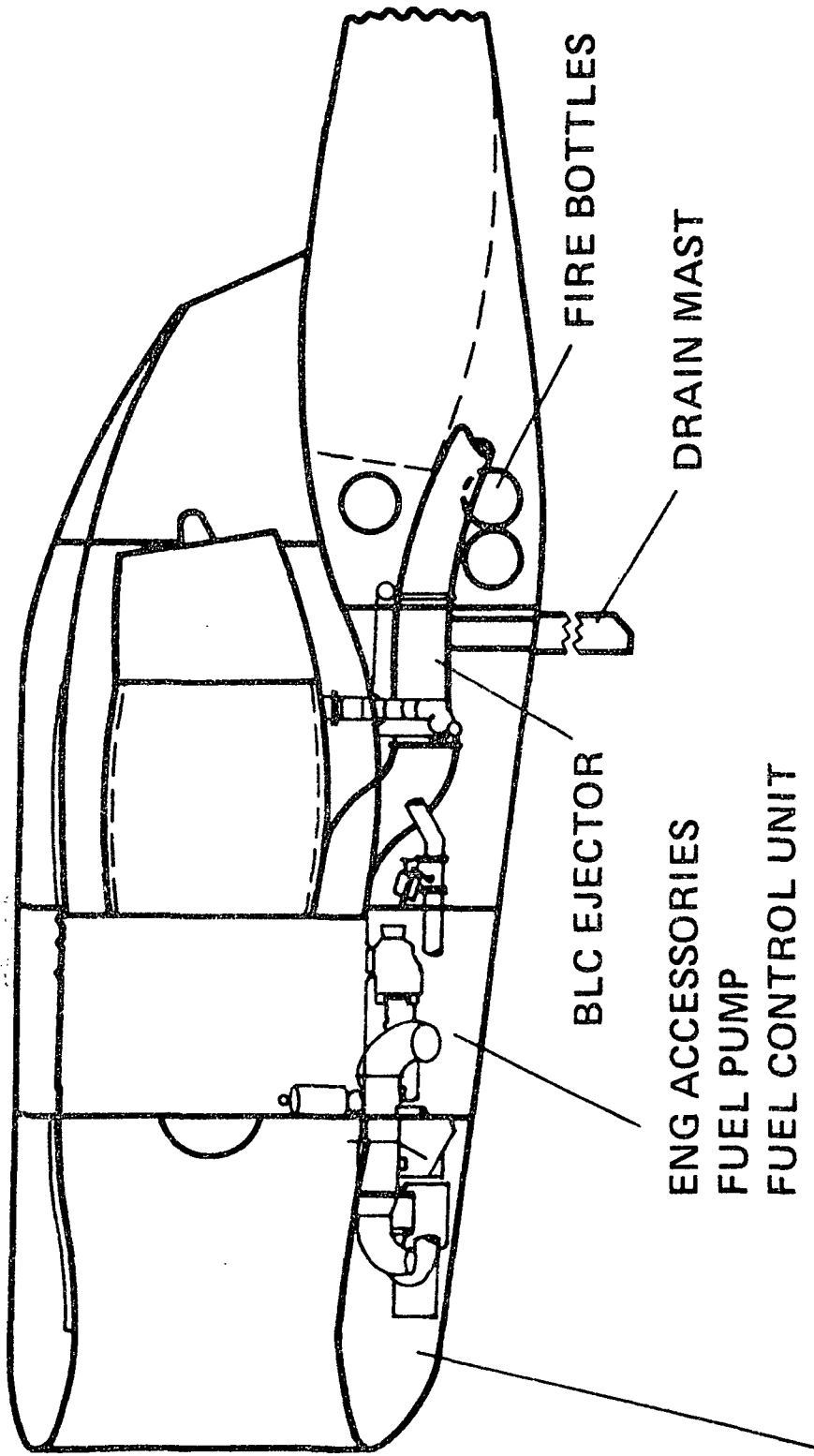

FIRE BOTTLES

DRAIN MAST

BLC EJECTOR

ENG ACCESSORIES
 FUEL PUMP
 FUEL CONTROL UNIT

STARTER
 HYD PUMP
 CDS GEN
 CDS COOLER AND FAN
 CDS ACCUMULATOR
 CDS FILTER

(a) Layout.

Figure 14.-- QSRA nacelle.

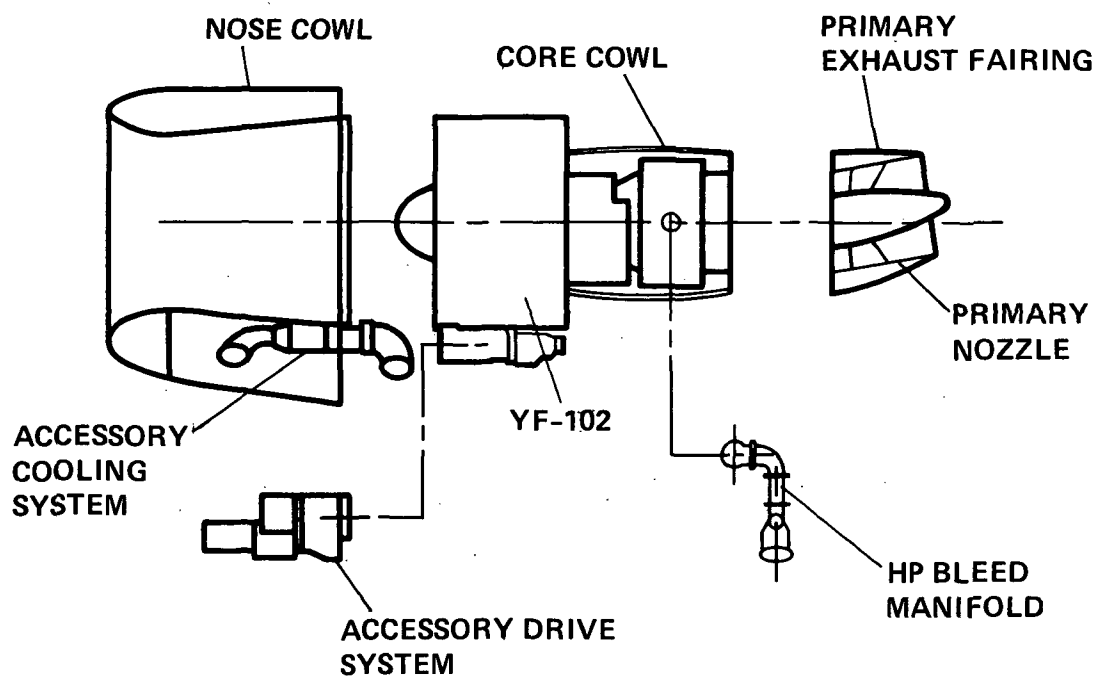

(b) Engine buildup.

Figure 14.- Concluded.

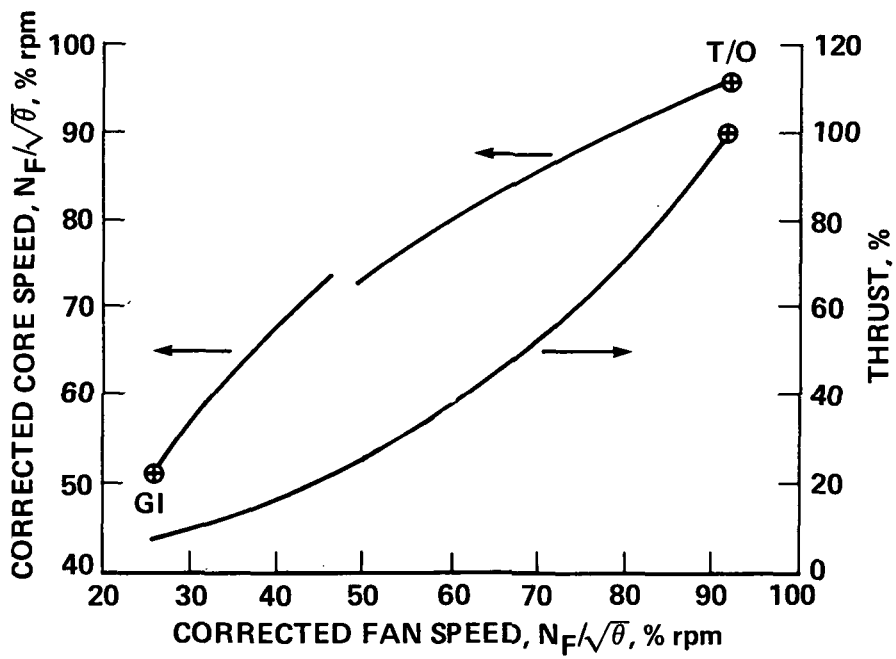

(a) Fan speed, core speed, and thrust relationships.

Figure 15.- YF-102 engine parameters.

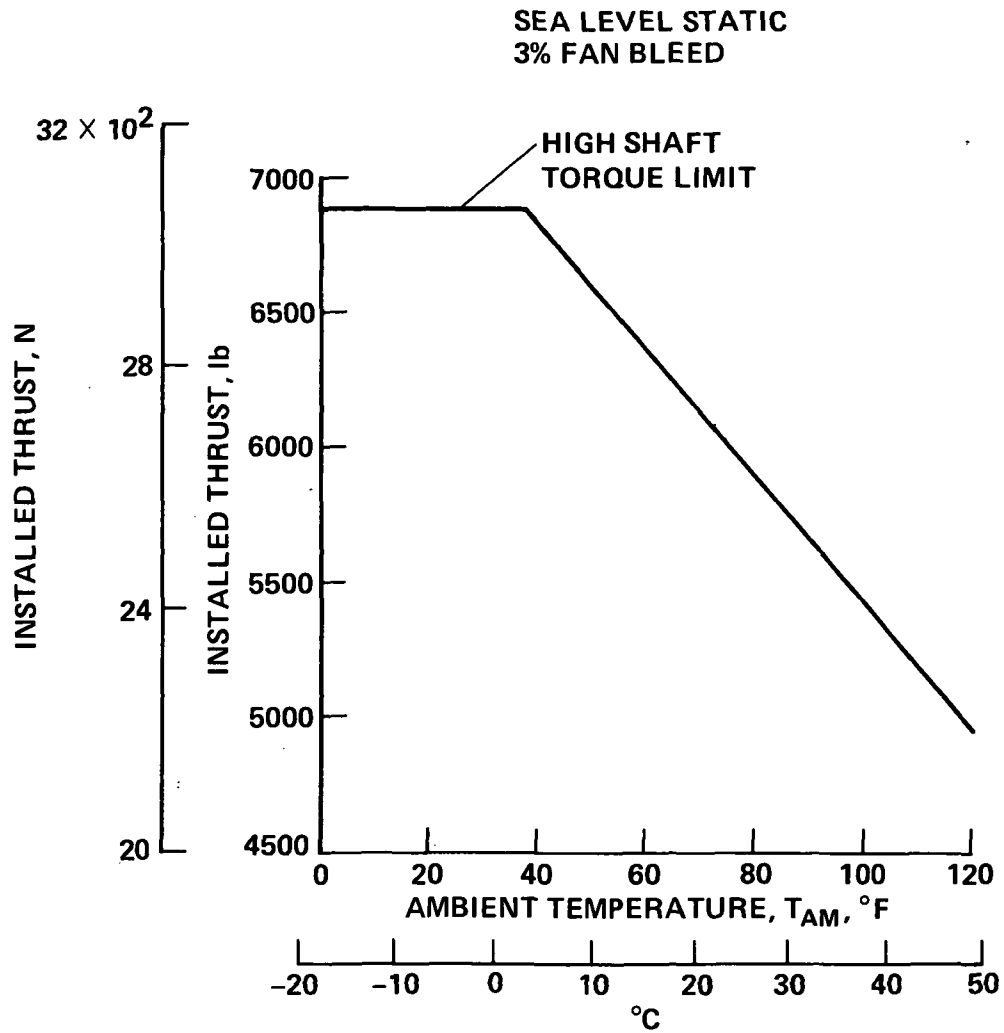

(b) Installed thrust.

Figure 15.- Concluded.

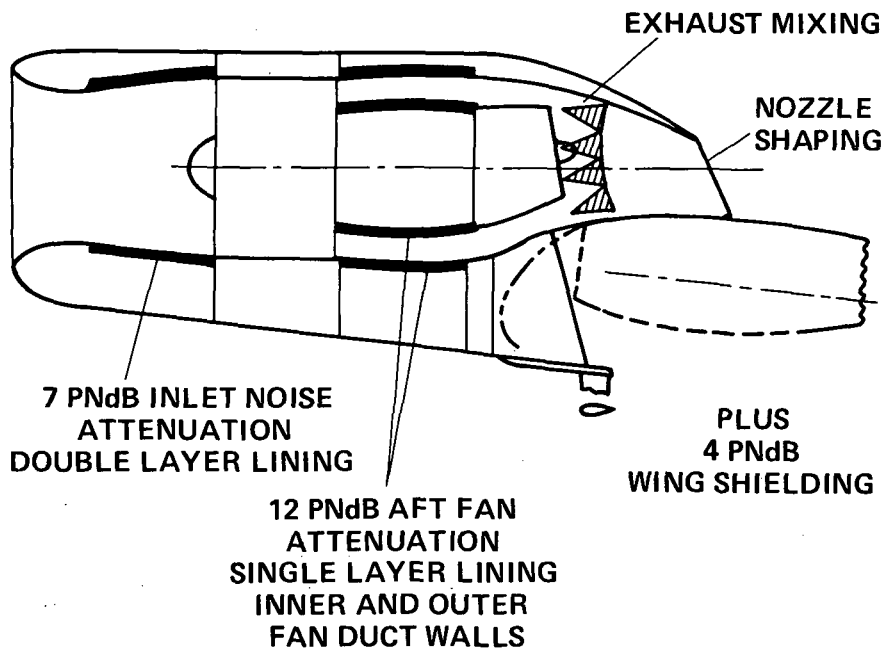

Figure 16.- Acoustic treatment in the QSRA nacelle.

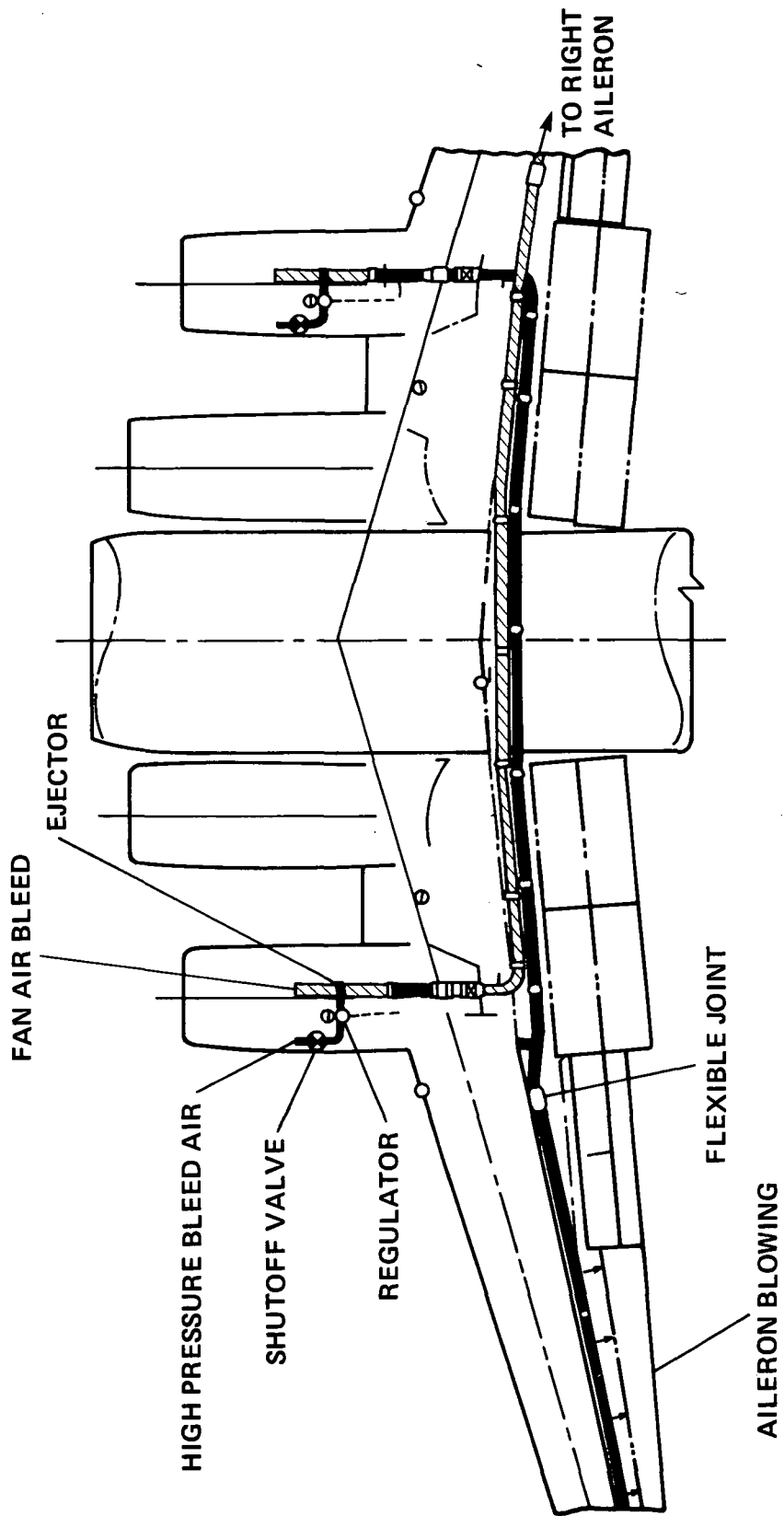

Figure 17.- Boundary-layer control (BLC) system ducting.

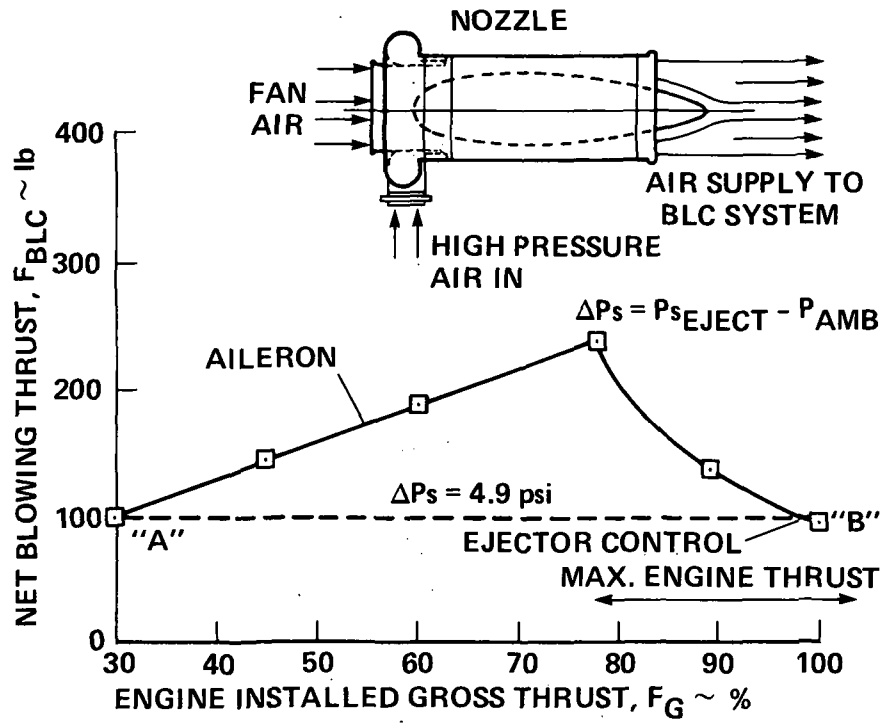
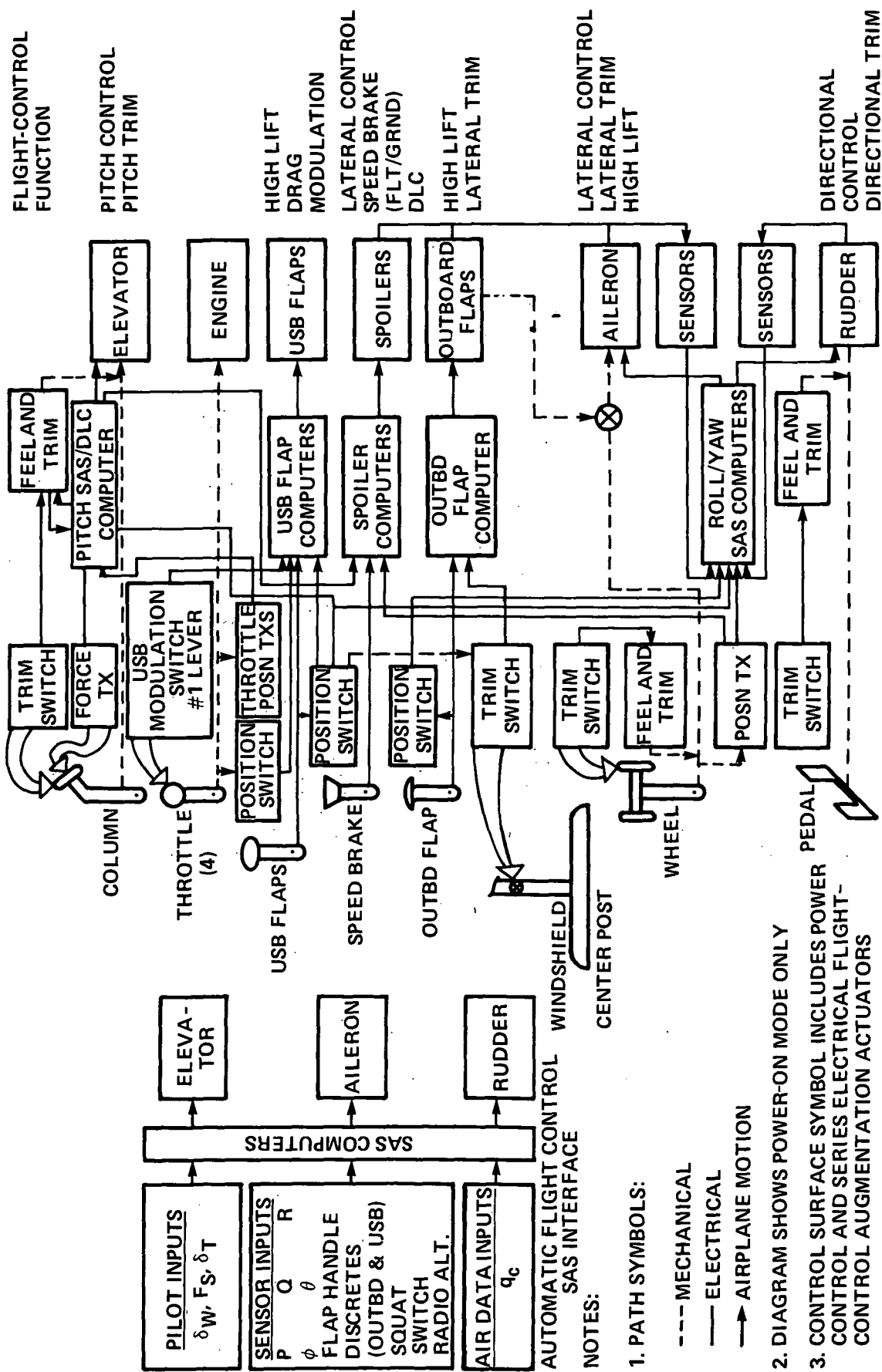
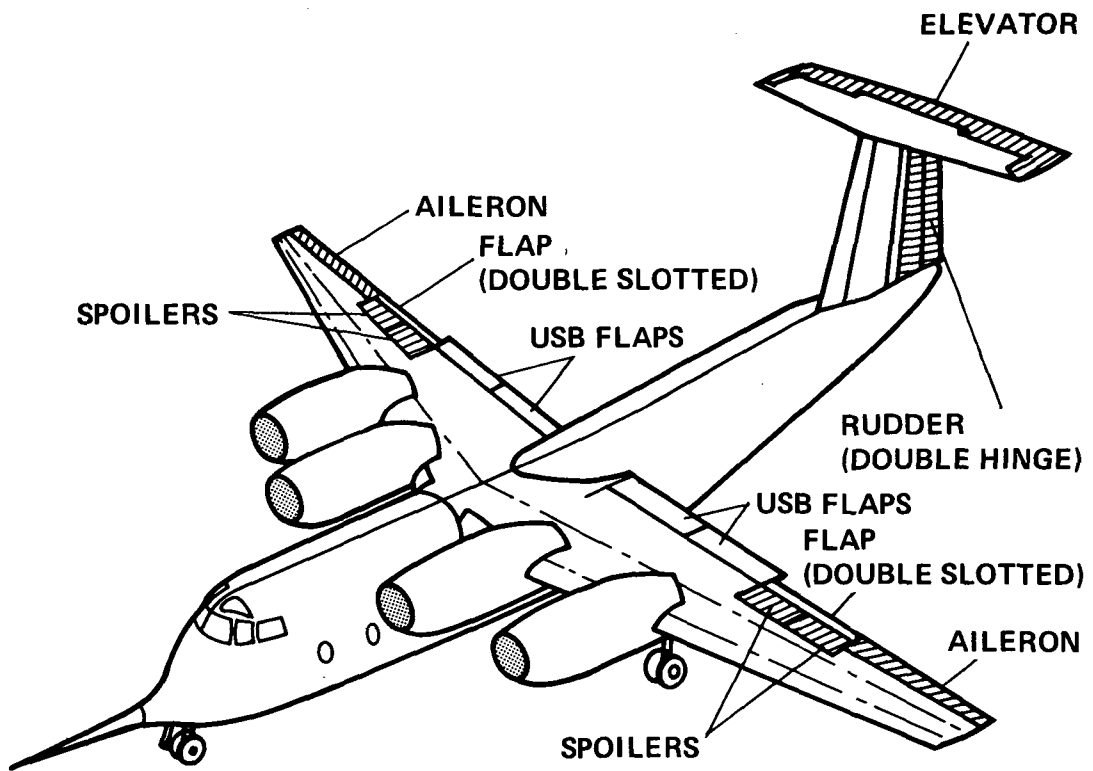

Figure 18.- Net blowing momentum of a BLC nozzle.



(a) Block diagram.

Figure 19.- Flight-control system.



(b) Flight-control surfaces.

Figure 19.- Concluded.

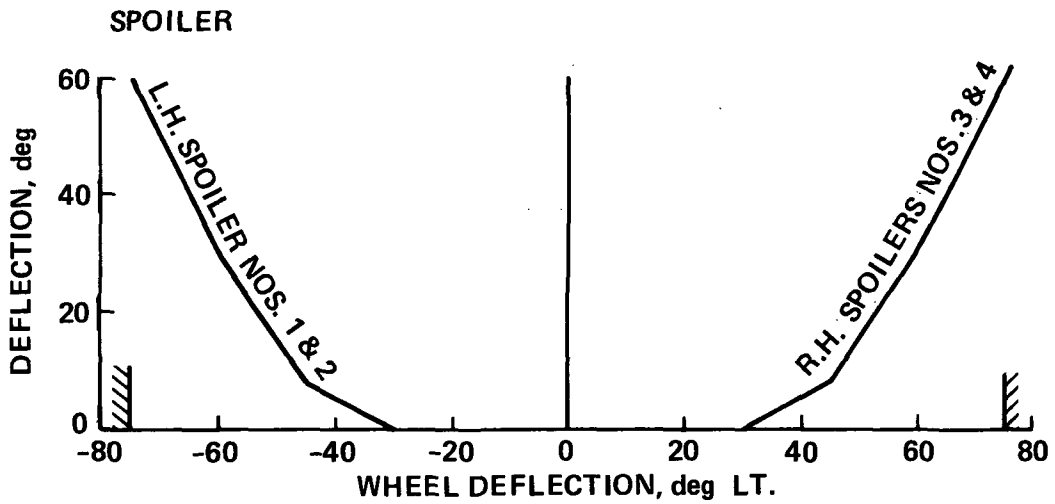
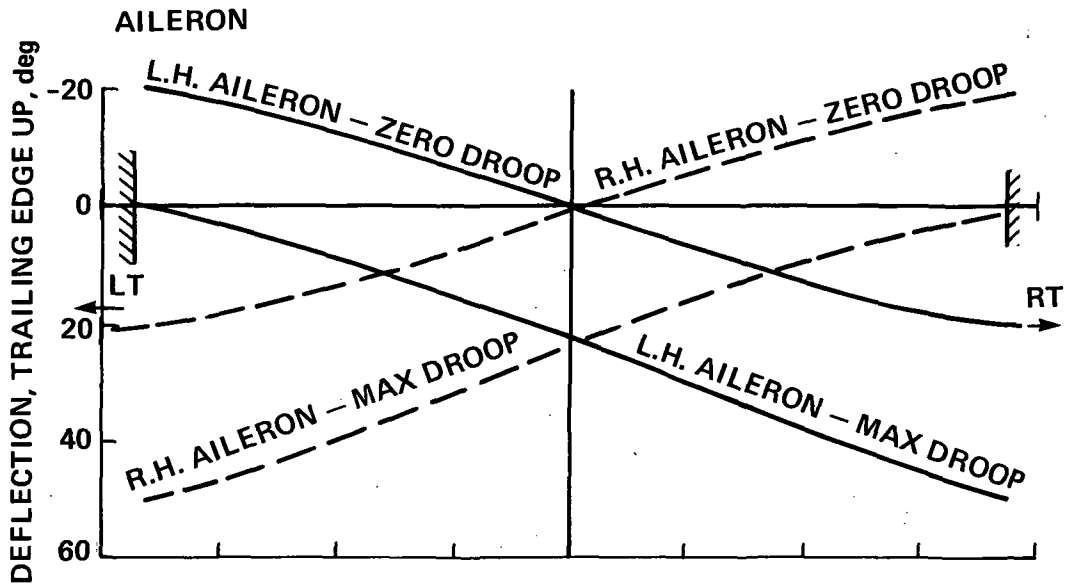

(b) Control gearing.

Figure 20.- Continued.

ALL ENGINES OPER.
MAX THRUST
GW = 48,000 lb
LATERAL CONTROL
WITH FULL WHEEL

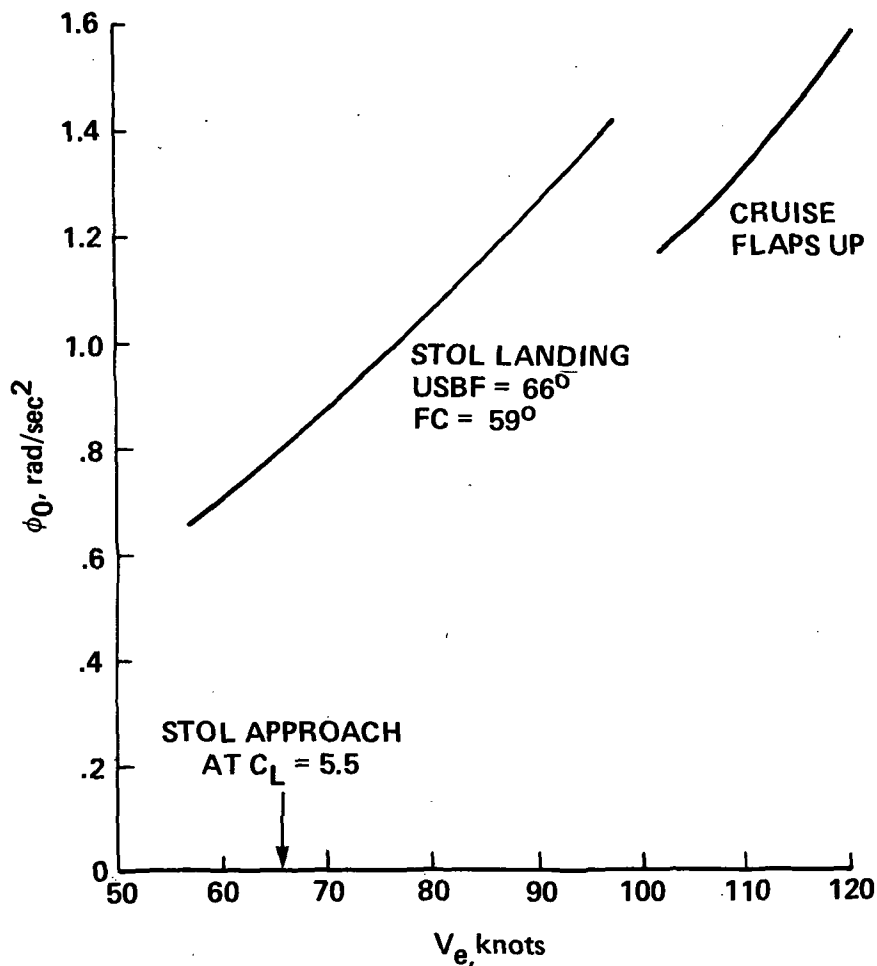

(c) Roll acceleration.

Figure 20.- Concluded.

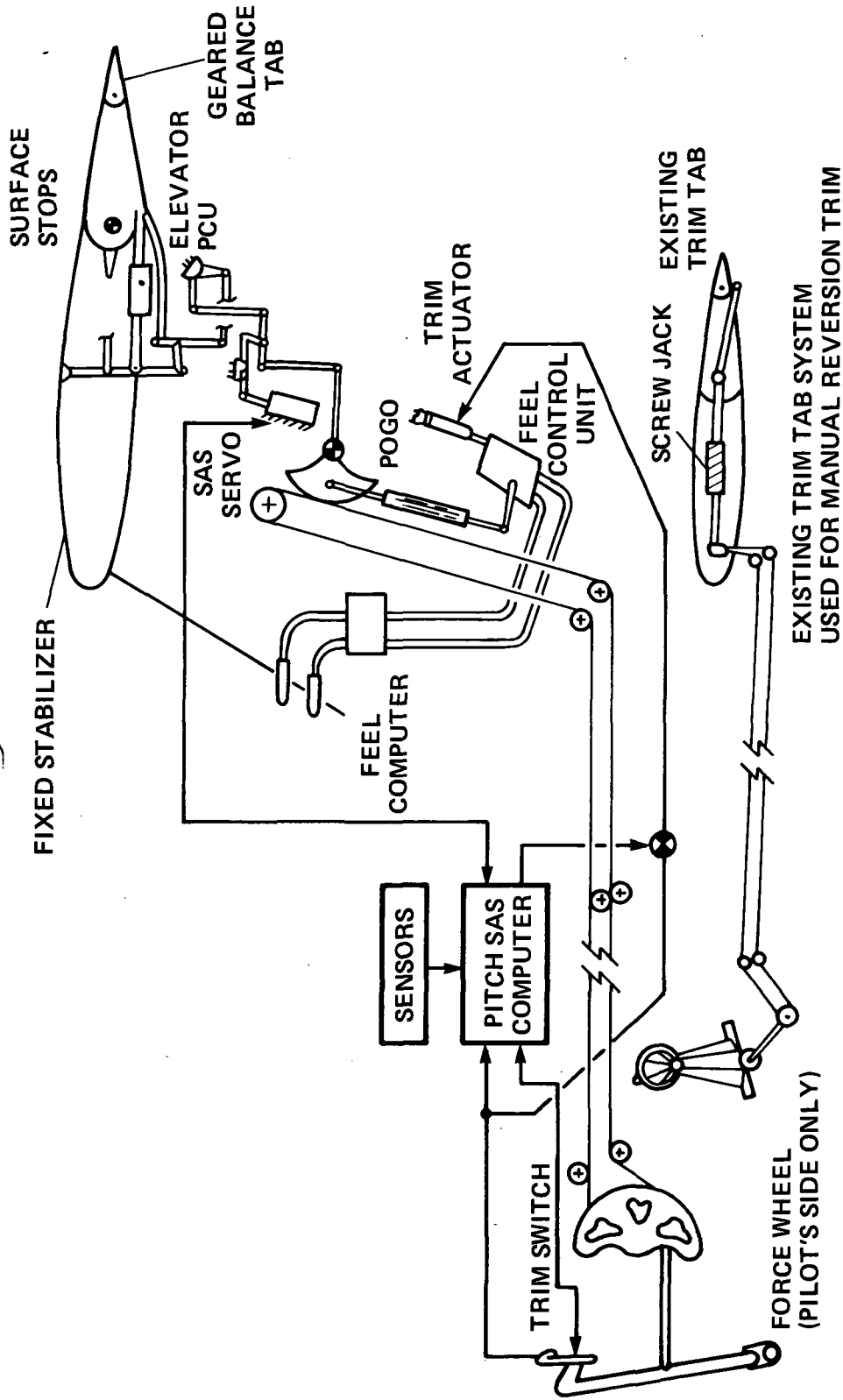

(a) Block diagram.

Figure 21.- Longitudinal control system.

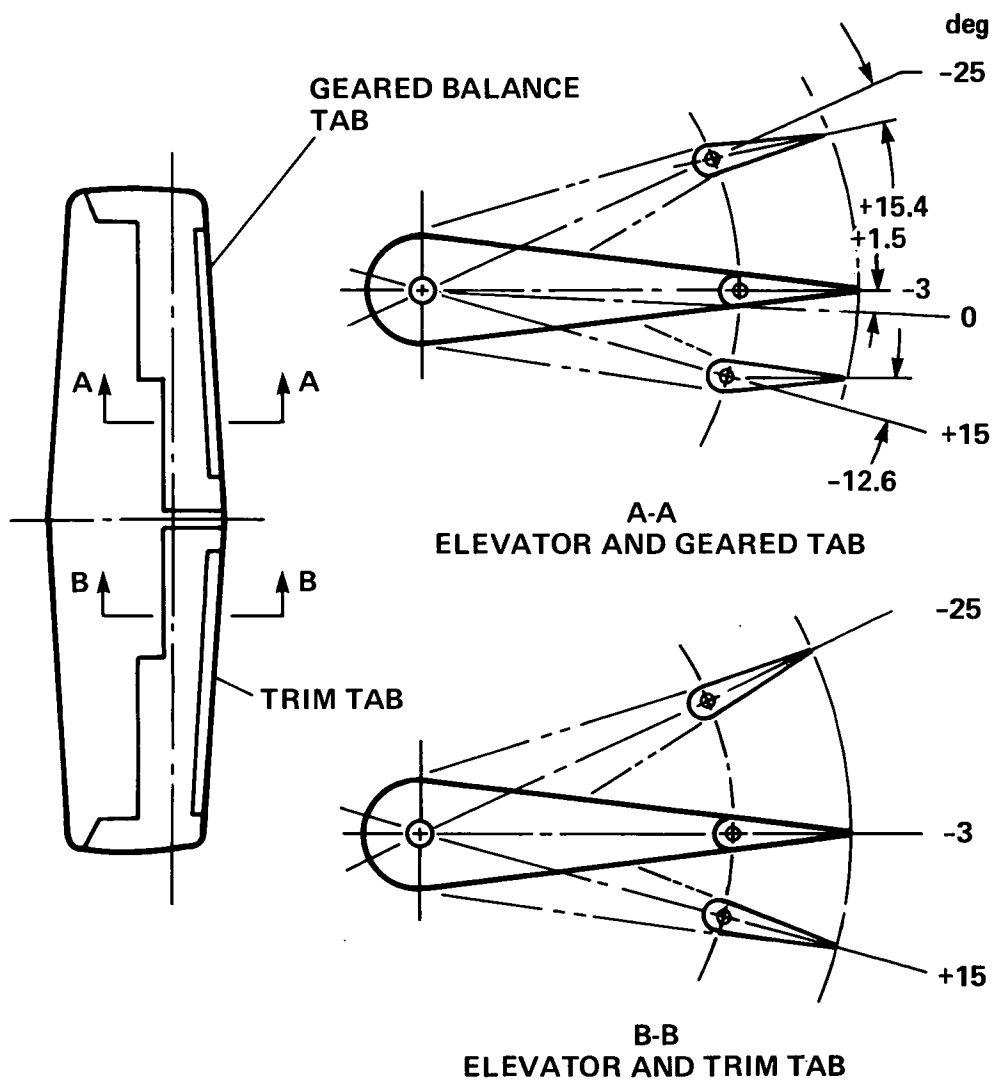

(b) Elevator movement.

Figure 21.- Continued.

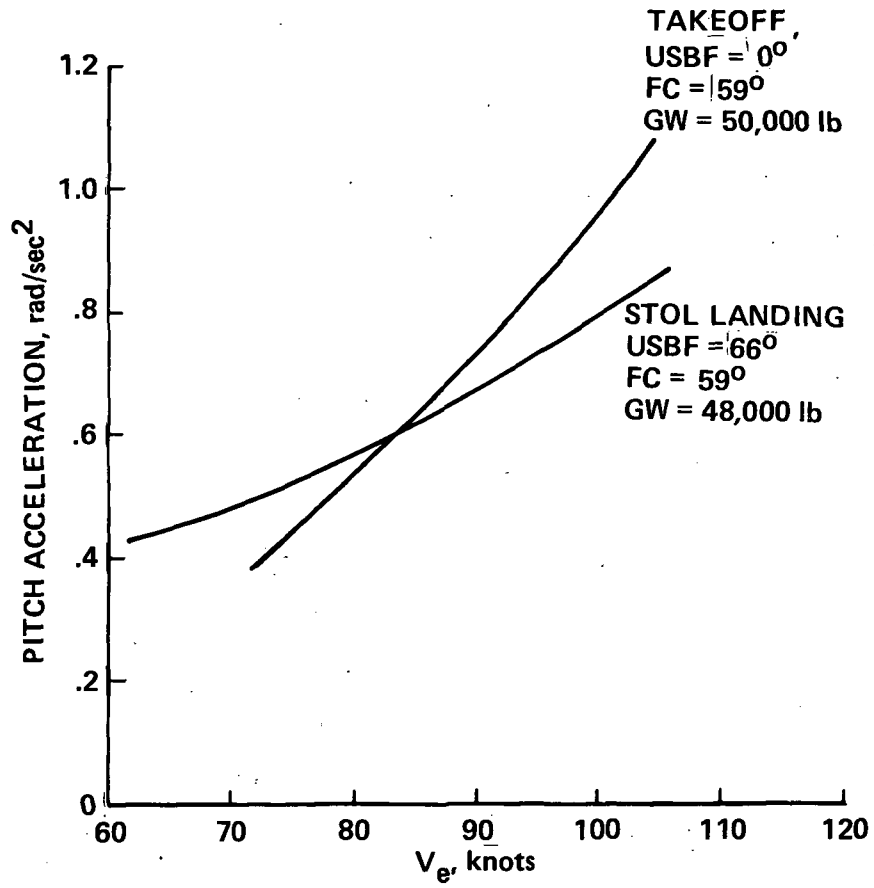

(c) Pitch acceleration.

Figure 21.- Concluded.

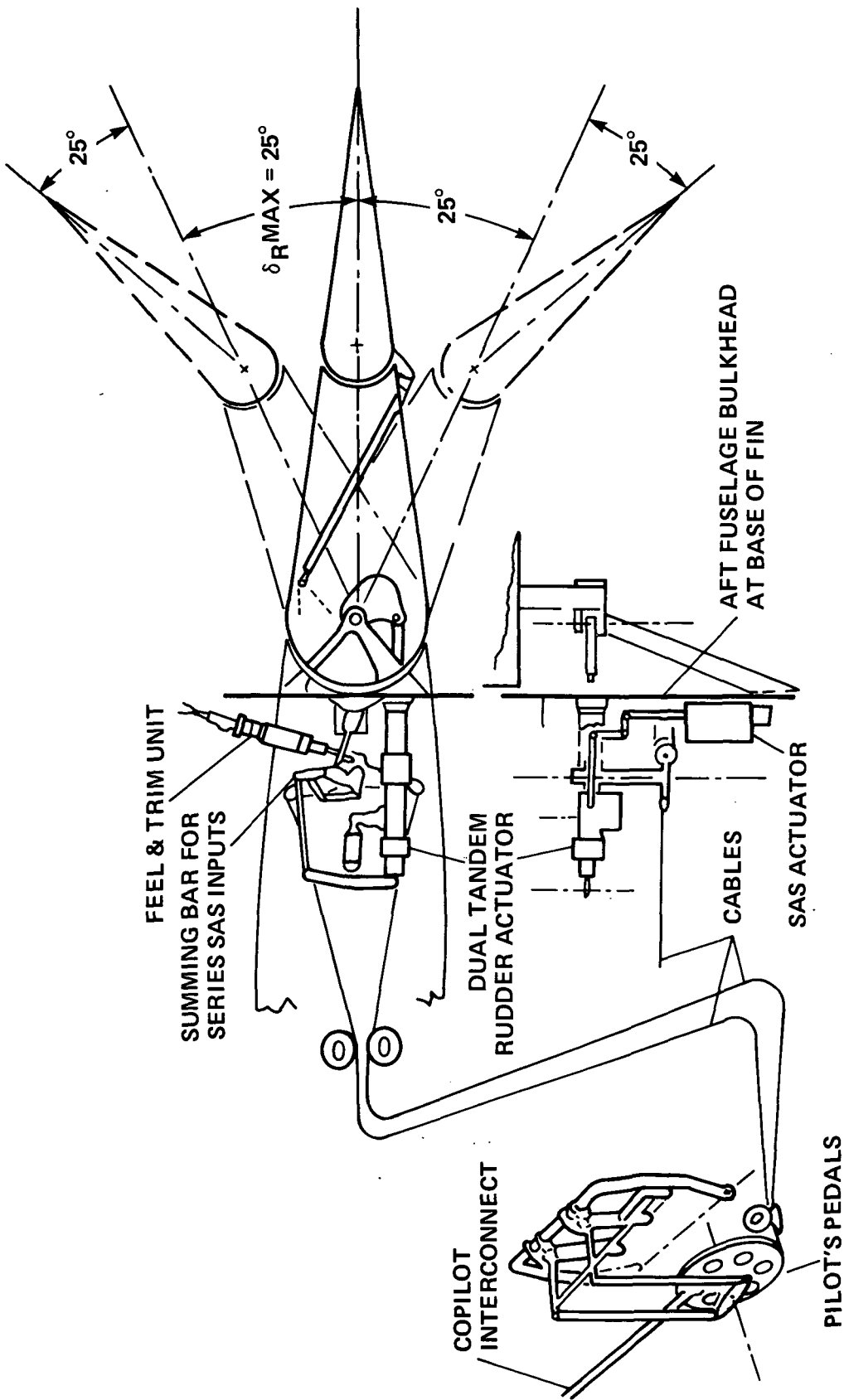

(a) Block diagram.

Figure 22.- Directional control system.

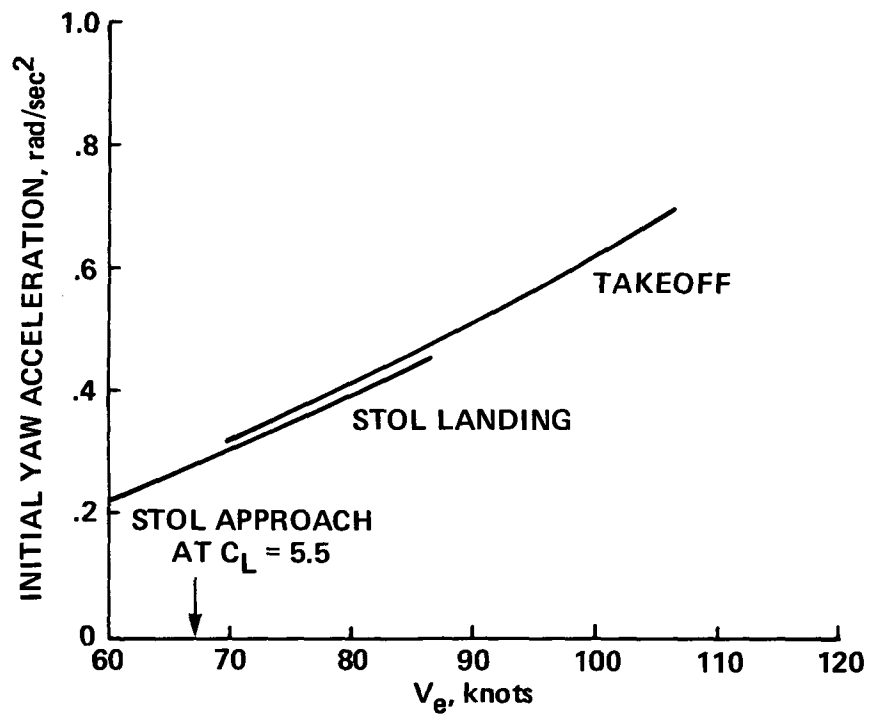

(b) Yaw acceleration.

Figure 22.- Concluded.

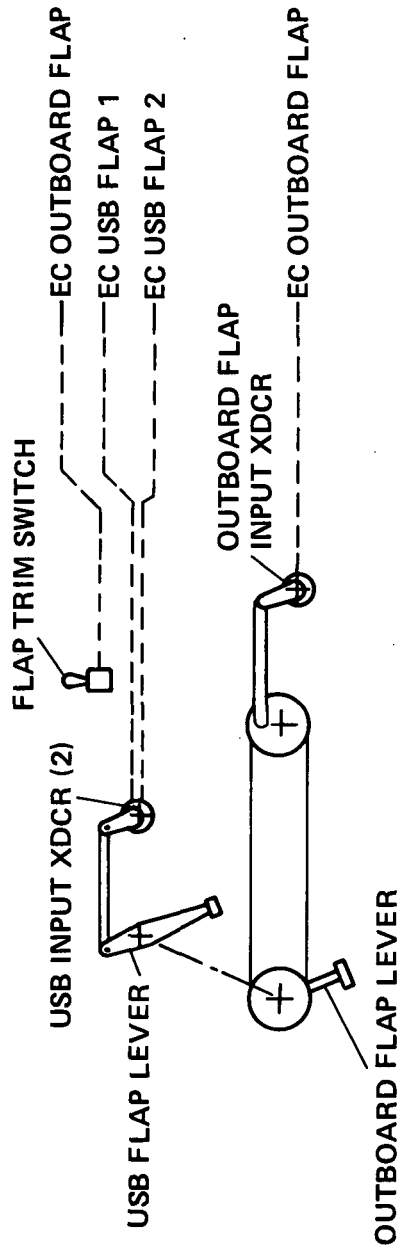

APL

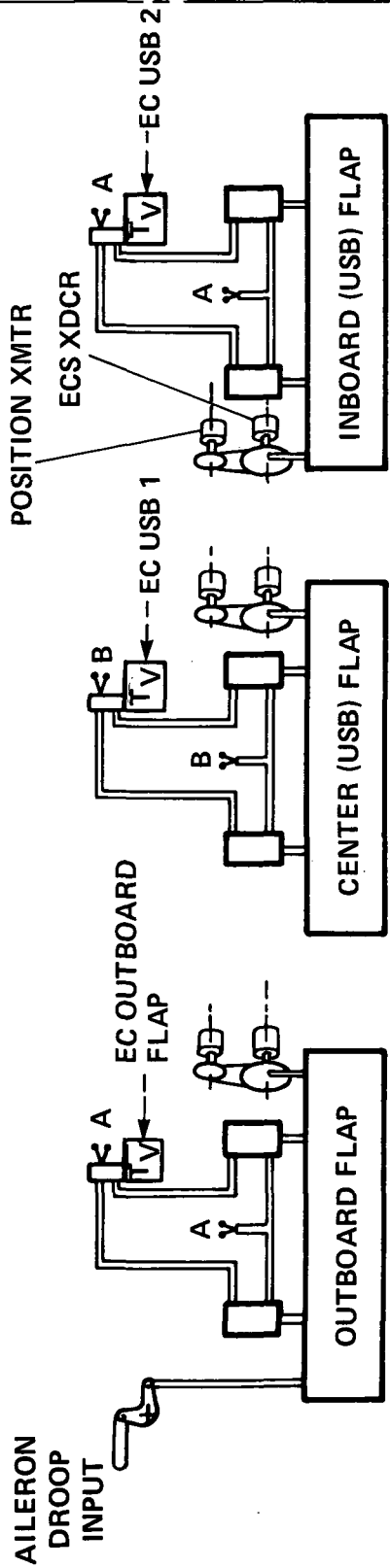

Figure 23.- Flap control system.

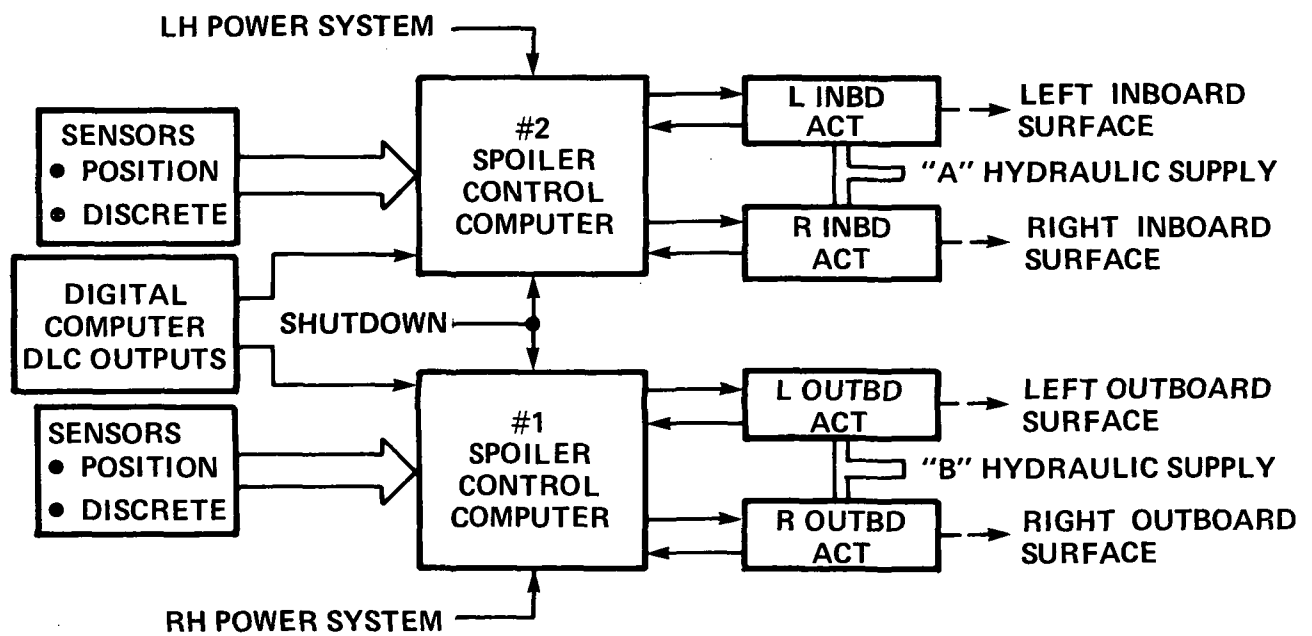

Figure 24.- Electric spoiler command system.

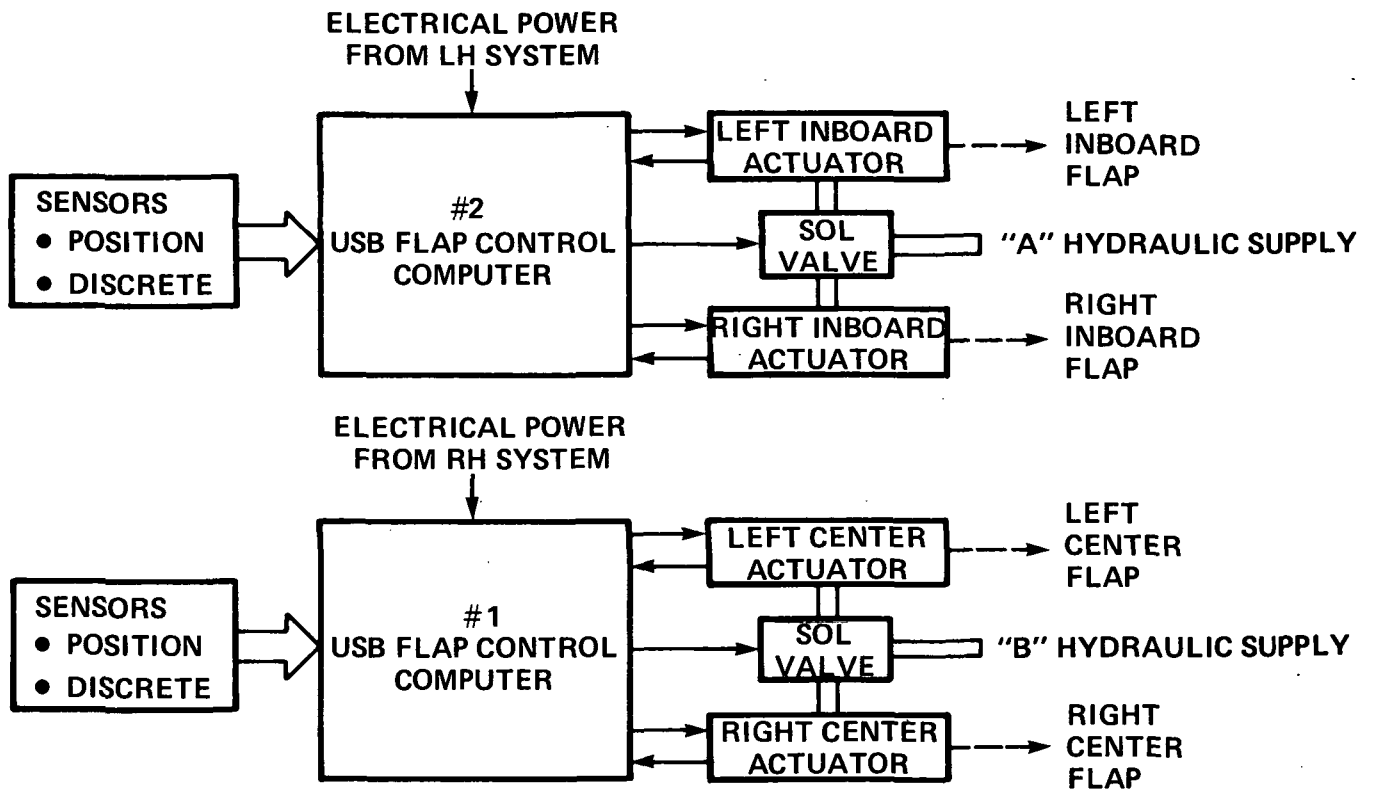

Figure 25.- Electric USB flap command system.

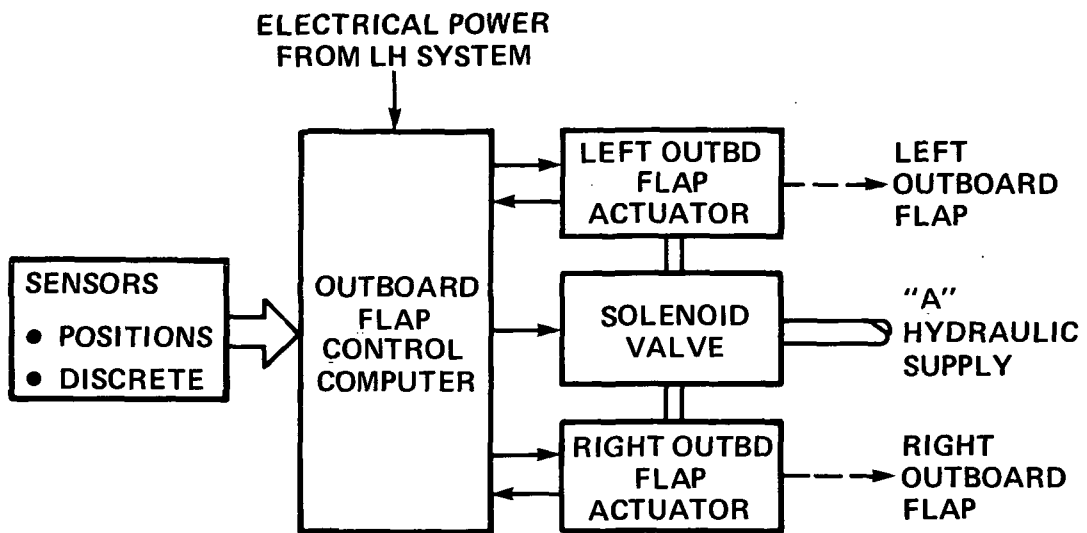

Figure 26.- Electric outboard flap command system.

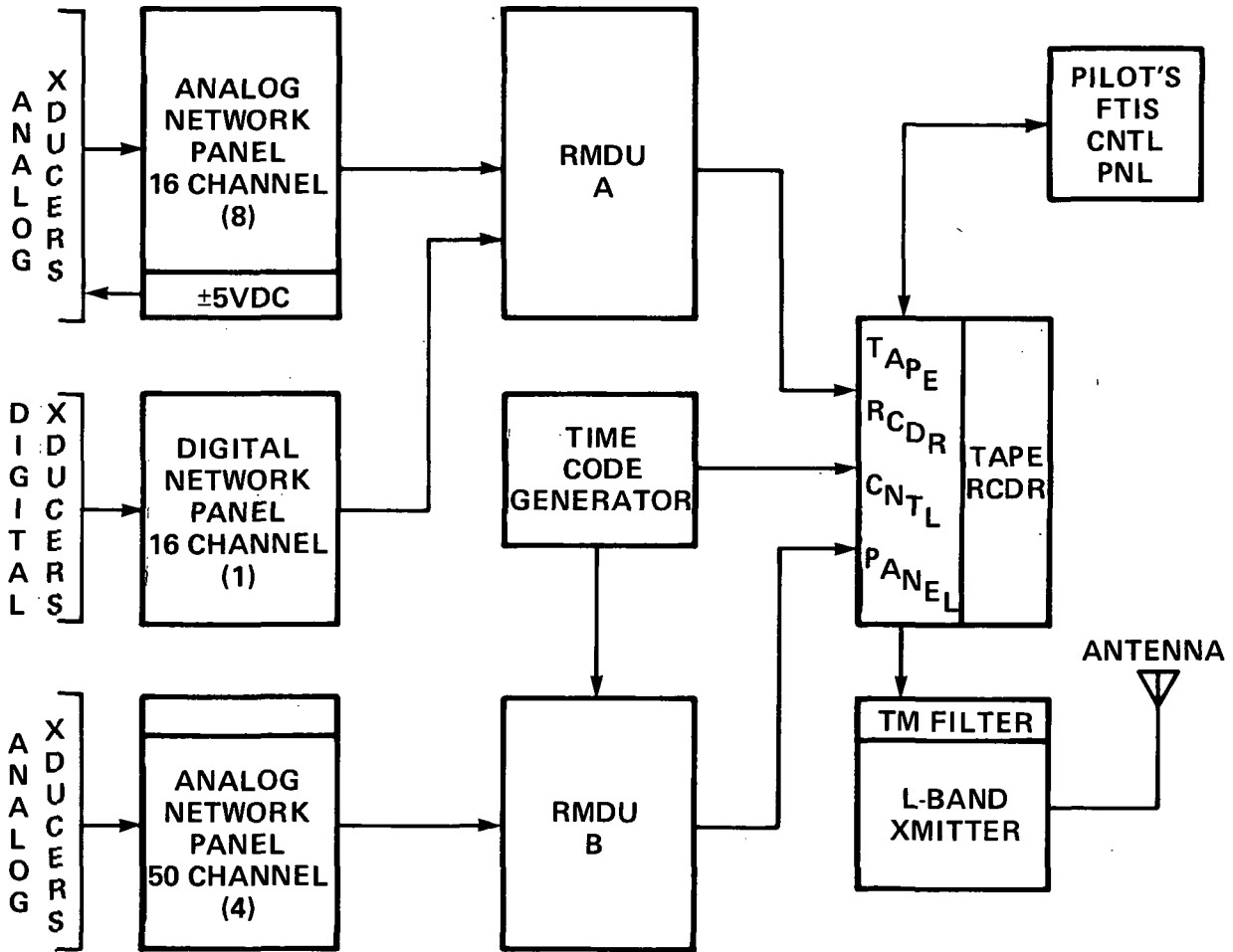

Figure 27.- QSRA flight-test instrumentation system.

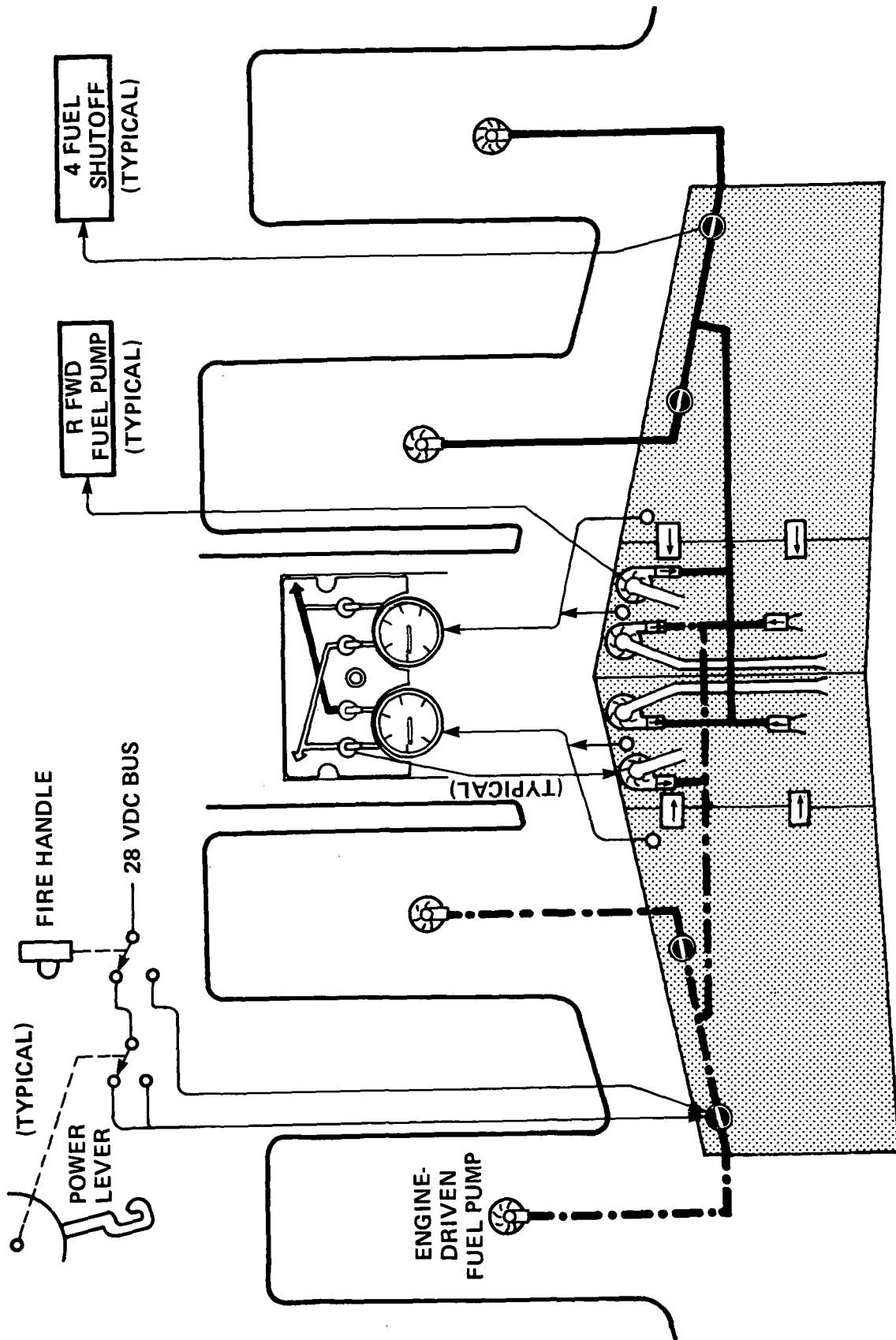

Figure 28.- Airplane fuel system.

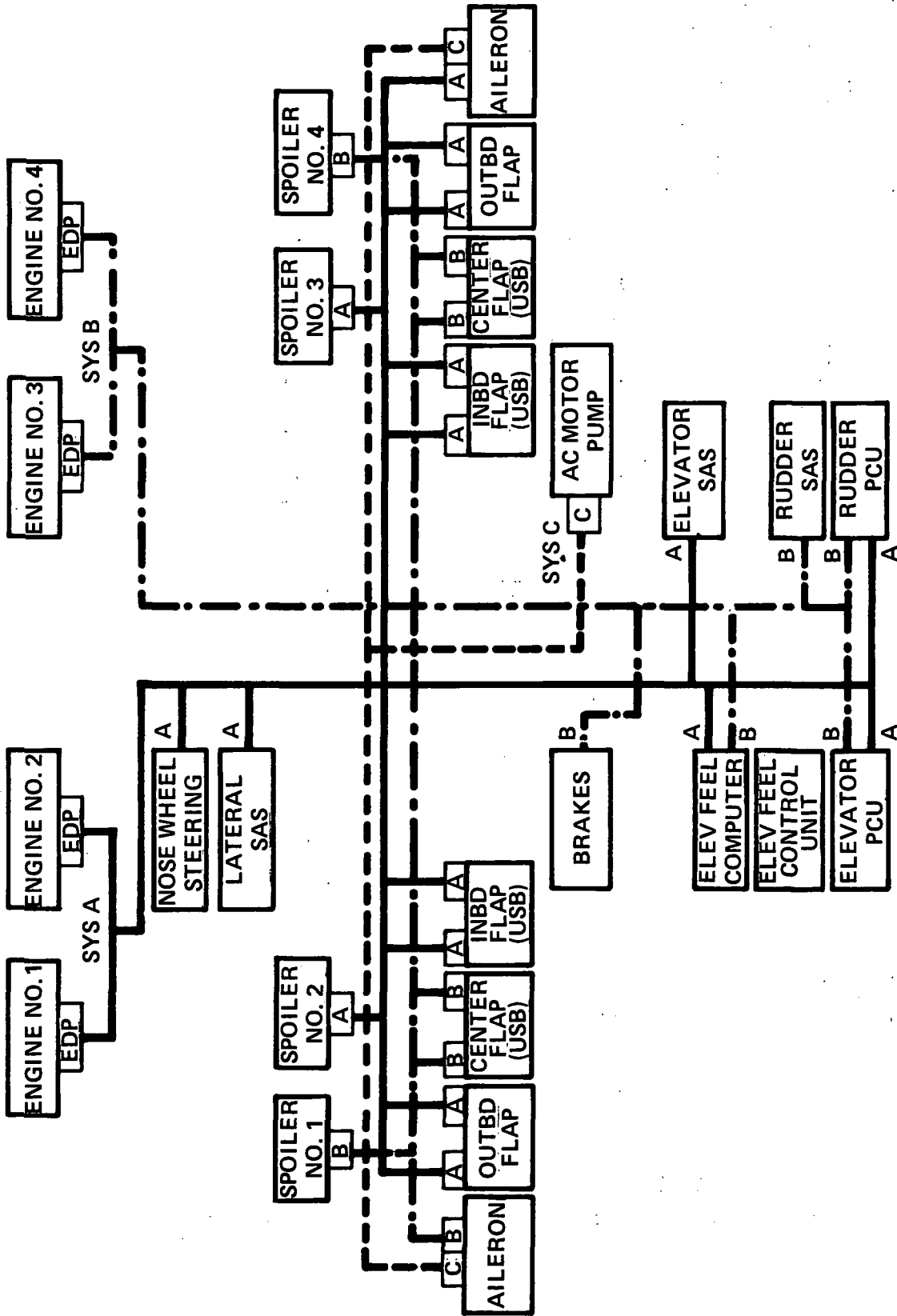

Figure 29.- Hydraulic power distribution.

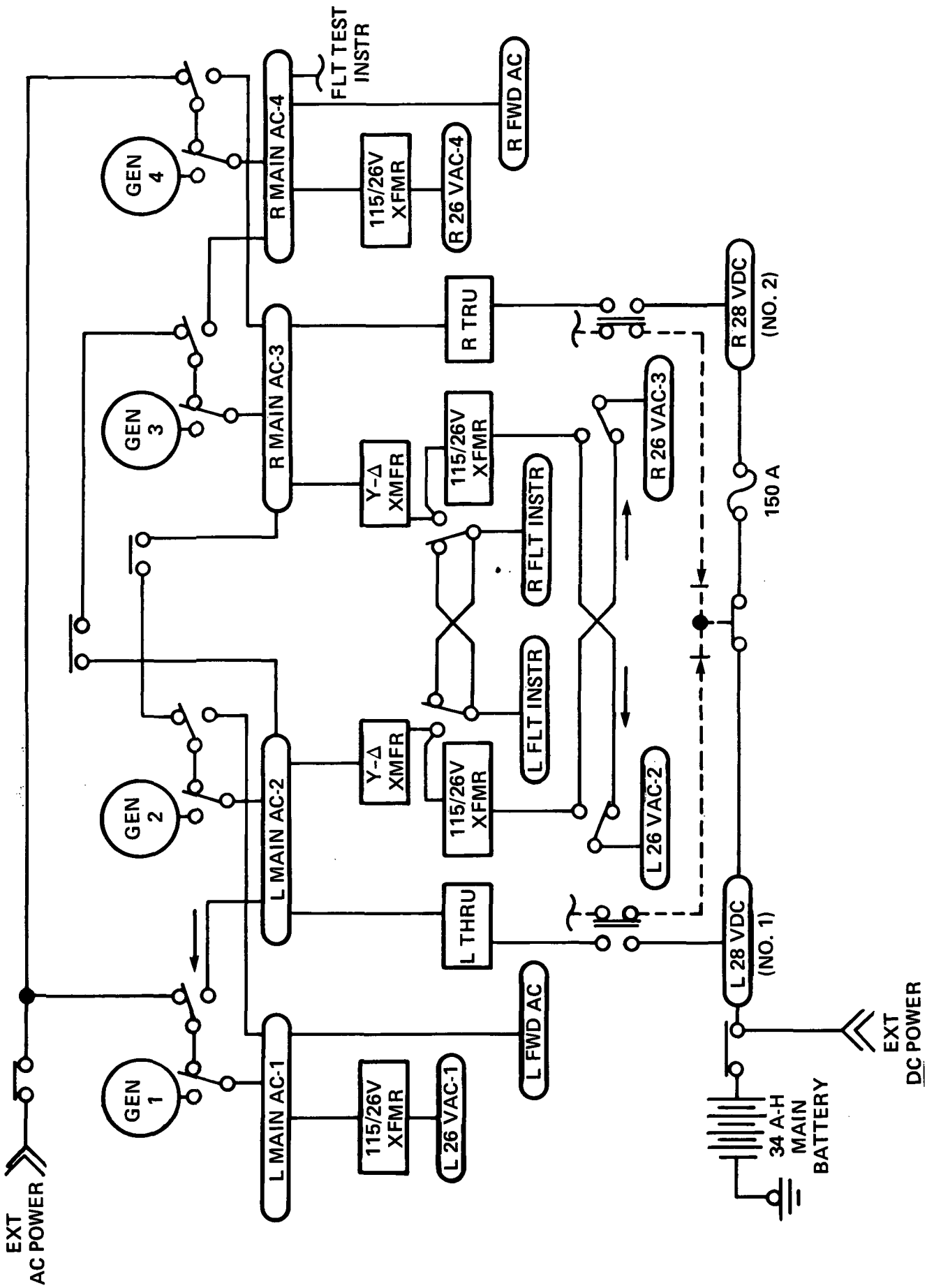

Figure 30.- QSRA electrical power system.

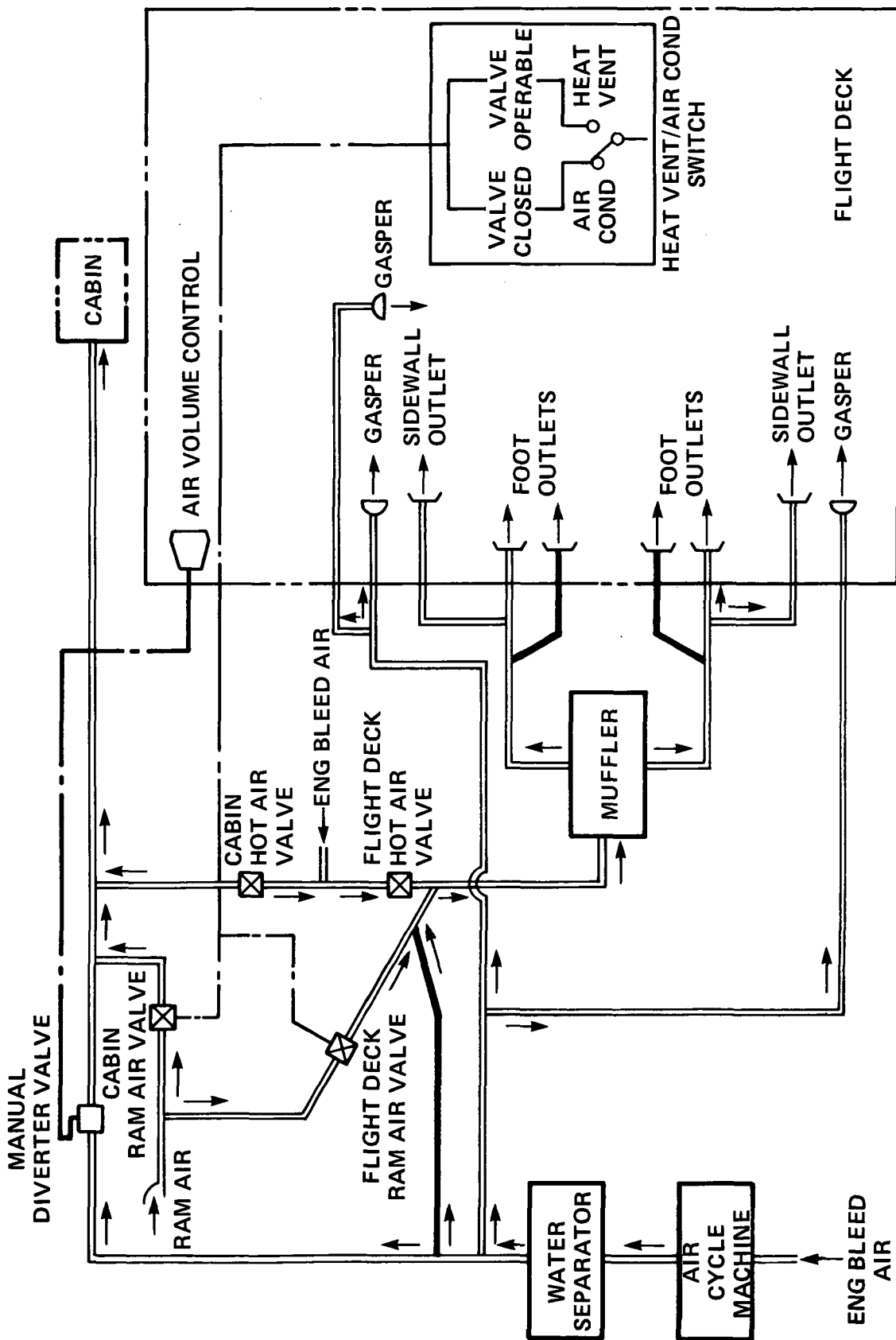
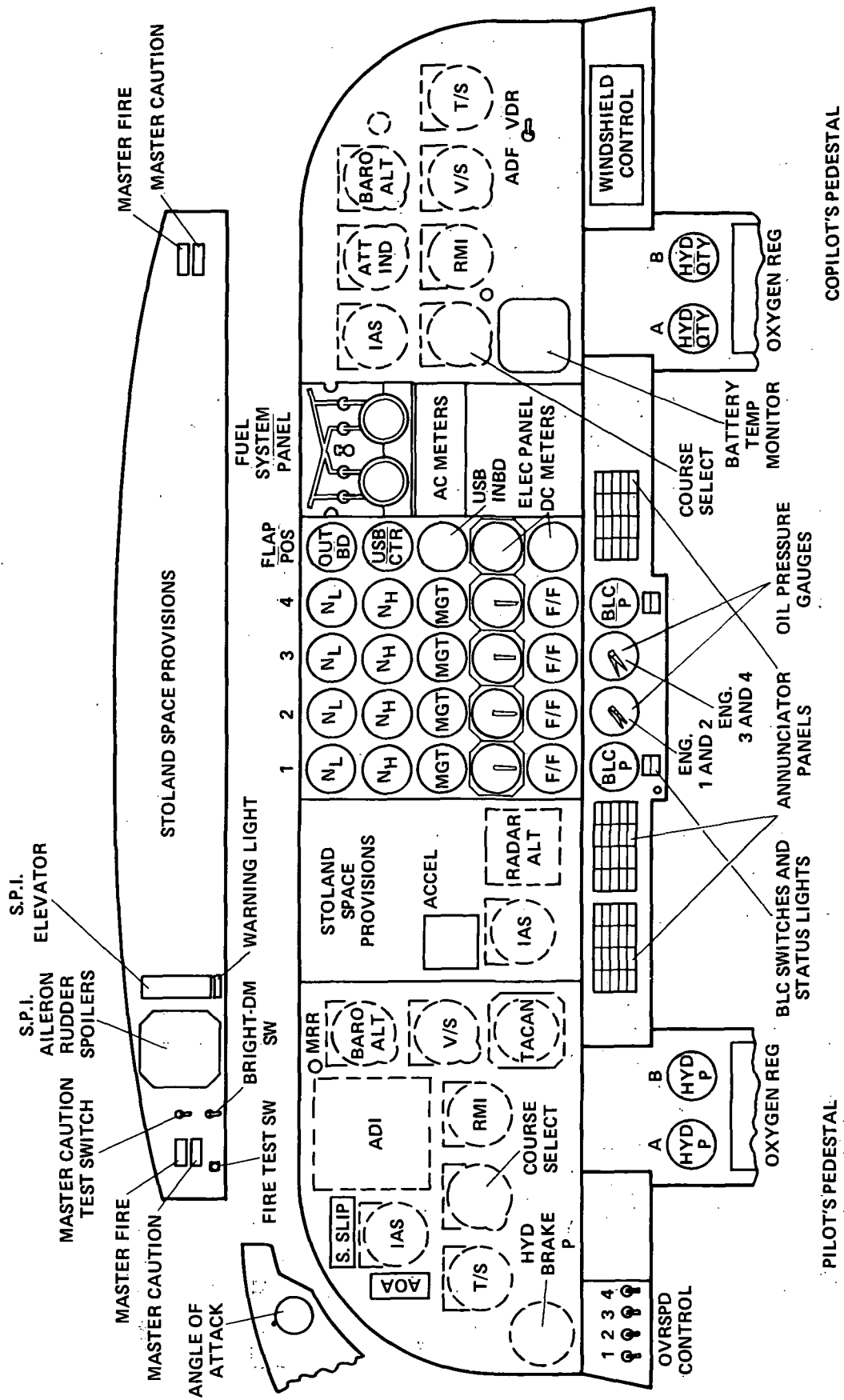
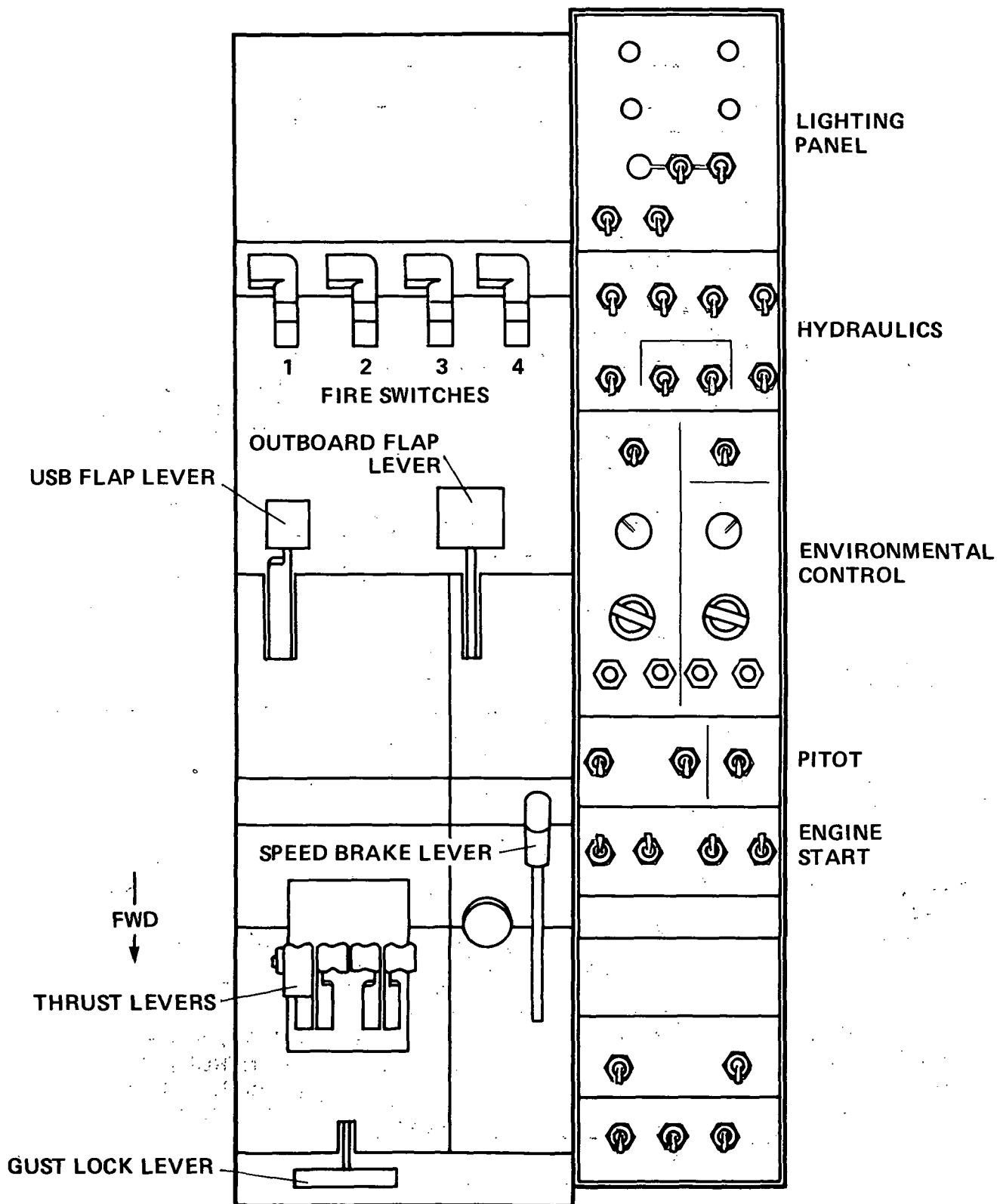

Figure 31.- Schematic diagram, conditioned air system.



(a) Control panel.

Figure 32.- Cockpit instruments.



(b) Overhead control panel.

Figure 32.- Continued.

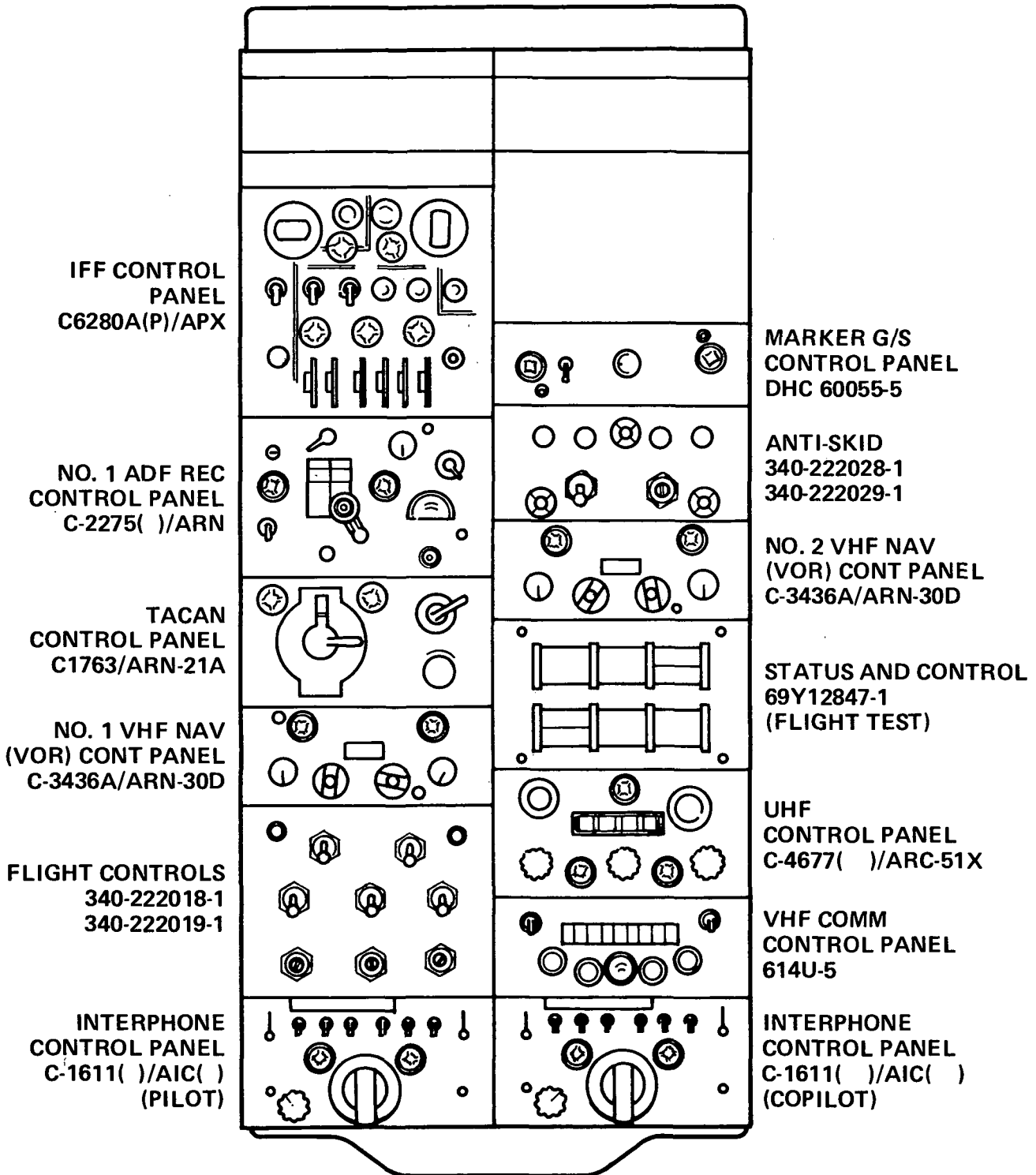

(c) Center pedestal.

Figure 32.- Concluded.

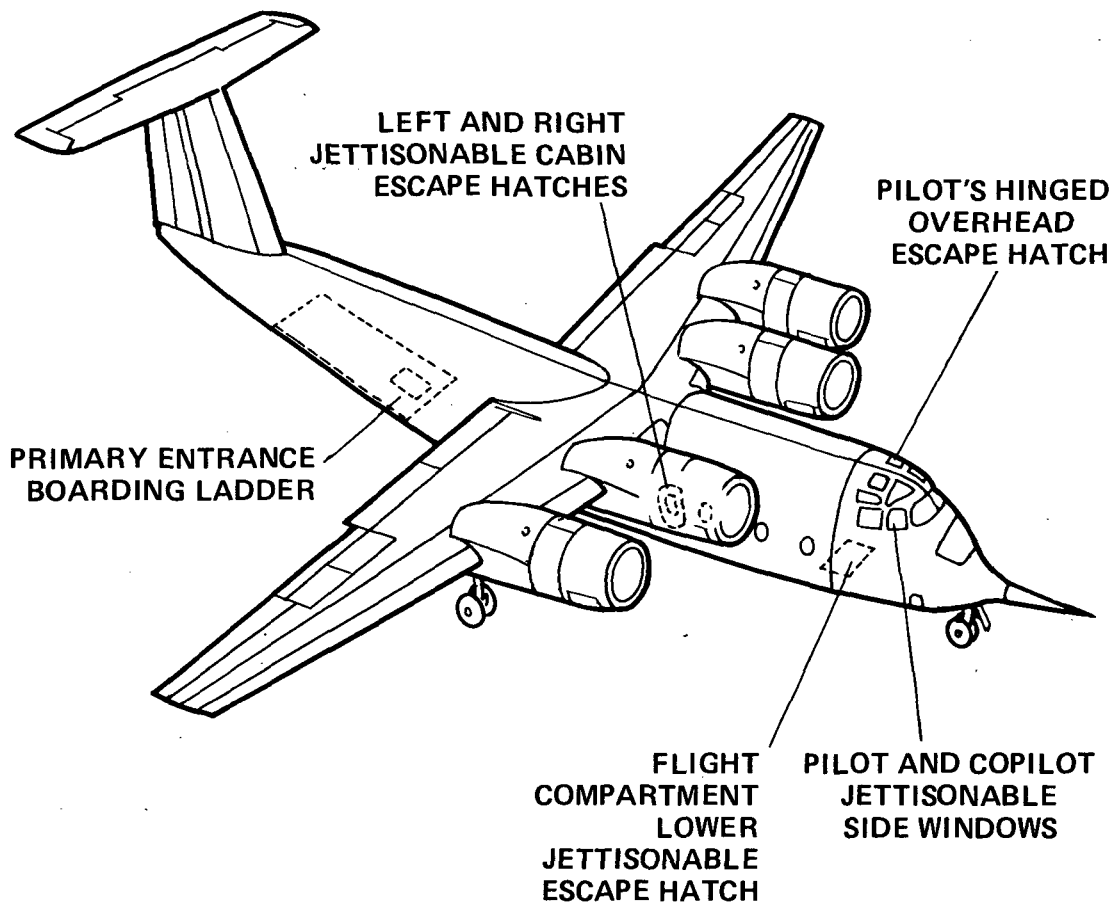

Figure 33.- Escape hatches.

1. Report No. NASA TM-81149	2. Government Accession No.	3. Recipient's Catalog No.	
4. Title and Subtitle QUIET SHORT-HAUL RESEARCH AIRCRAFT FAMILIARIZATION DOCUMENT		5. Report Date	
		6. Performing Organization Code	
7. Author(s) Robert C. McCracken		8. Performing Organization Report No. A-7975	
		10. Work Unit No. 769-02-01	
9. Performing Organization Name and Address Ames Research Center, NASA Moffett Field, Calif. 94035		11. Contract or Grant No.	
		13. Type of Report and Period Covered Technical Memorandum	
12. Sponsoring Agency Name and Address National Aeronautics and Space Administration Washington, D. C. 20546		14. Sponsoring Agency Code	
		15. Supplementary Notes	
16. Abstract The design features and general characteristics of the NASA Quiet Short-Haul Research Aircraft are described. Aerodynamic characteristics and performance are discussed based on predictions and early flight-test data. Principle airplane systems, including the airborne data-acquisition system, are also described. The aircraft was designed and built to fulfill the need for a national research facility to explore the use of upper-surface-blowing propulsive-lift technology in providing short takeoff and landing capability, and perform advanced experiments in various technical disciplines such as aerodynamics, propulsion, stability and control, handling qualities, avionics and flight-control systems, trailing-vortex phenomena, acoustics, structure and loads, operating systems, human factors, and airworthiness/certification criteria. An unusually austere approach using experimental shop practices resulted in a low cost and high research capability.			
17. Key Words (Suggested by Author(s)) Short-haul Aircraft design Upper surface blowing Research aircraft STOL		18. Distribution Statement Available from Originating Office Only STAR CATEGORY - 05	
19. Security Classif. (of this report) Unclassified	20. Security Classif. (of this page) Unclassified	21. No. of Pages 76	22. Price*