

NASA
TP
1602
c.1

NASA Technical Paper 1602

LOAN COPY: RETURN TO
AFWL TECHNICAL LIBRARY
KIRTLAND AFB, N. M.



Landing Approach Airframe Noise Measurements and Analysis

Paul L. Lasagna, Karen G. Mackall,
Frank W. Burcham, Jr., and Terrill W. Putnam

JANUARY 1980

NASA



NASA Technical Paper 1602

Landing Approach Airframe Noise Measurements and Analysis

Paul L. Lasagna, Karen G. Mackall,
Frank W. Burcham, Jr., and Terrill W. Putnam
*Dryden Flight Research Center
Edwards, California*



National Aeronautics
and Space Administration

**Scientific and Technical
Information Office**

1980

LANDING APPROACH AIRFRAME NOISE MEASUREMENTS AND ANALYSIS

Paul L. Lasagna, Karen G. Mackall,
Frank W. Burcham, Jr., and Terrill W. Putnam
Dryden Flight Research Center

INTRODUCTION

Significant progress has been made in designing and building low-noise aircraft propulsion systems. The application of propulsion-noise-reduction technology to wide-bodied jet aircraft, such as the B-747, DC-10, and L-1011 aircraft has resulted in dramatic reductions in aircraft noise around our nation's airports. However, communities around the airports are demanding greater reductions in aircraft noise. Further reductions in aircraft propulsion noise may be feasible, but studies and flight tests (refs. 1 and 2) indicate that further noise reduction on approach will also require the reduction of the airframe noise, which has been found to be within 10 effective perceived noise decibels of the current (1969) FAR Part 36 approach-noise certification standards (ref. 3).

Airframe noise is the noise generated by an aircraft flying through the air without the propulsion system or auxiliary power units operating. This noise is produced by air flowing over and around the aircraft. It becomes most serious for an aircraft in the landing configuration, where regions of turbulent flow are produced when the wing slats and flaps are extended and the landing gear are lowered.

The first flights to investigate airframe noise used gliders and propeller-driven aircraft (ref. 4). The largest aircraft tested was a CV-240 that weighed approximately 174,000 newtons. The airframe noise signature of an F-106B airplane has also been obtained (ref. 5). Subsequent flight tests were made with a C-5A aircraft, which weighs approximately 2,677,000 newtons, with the engines at idle power (ref. 6). However, the C-5A test data were limited to frequencies of less than 400 hertz because of the engine noise at the higher frequencies.

Since the airframe noise sources were not well quantified by existing analytical techniques, particularly for the landing-gear-down configuration, a flight research program was initiated by the National Aeronautics and Space Administration in 1972

to investigate the nature and relative importance of airframe noise source mechanisms. A series of landing approaches was flown at the NASA Dryden Flight Research Center using four aircraft: an AeroCommander, a JetStar, a CV-990, and a B-747. The resulting data have contributed to the development of more recent prediction techniques for airframe noise (refs. 7, 8, and 9). These techniques are also based in part on the data from references 1, 4, 5, and 6. Another airframe noise prediction technique was developed by A. S. Hersh (ref. 10) based on the data reported in reference 11 and additional data obtained at the NASA Dryden Flight Research Center and is included in this paper. The tests are summarized in references 1 and 11. This paper presents the results of the tests in detail.

Ideally, airframe noise would be measured during landing approaches with the airplane's engines shut down. For the AeroCommander and JetStar aircraft, it was possible to make approaches with the engines off as well as at idle power. For the CV-990 and B-747 aircraft, landing approaches were made with the engines at idle power only. Noise-measurement instrumentation, the data-reduction technique, and the test procedures are described. Overall sound pressure levels (OASPL) and noise spectra for the test aircraft and empirical correlations between airframe noise and aircraft parameters are presented.

SYMBOLS AND ABBREVIATIONS

Units are given in the International System of Units (SI). Most of the measurements were made in U.S. Customary Units and converted to SI Units.

a	speed of sound, m/sec
C_{D_w}	drag coefficient of wing
\bar{c}	wing mean aerodynamic chord, m
EPNL	effective perceived noise level, EPNdB
K_w	acoustic constant for wing
K_{wf}	acoustic constant for wing with flaps extended
OASPL	overall sound pressure level, dB
PNL	perceived noise level, PNdB
$\overline{p_{ref}}^2$	reference mean square sound pressure, $(20\mu\text{Pa})^2$
R	spherical coordinate, m

SPL	sound pressure level, dB
S_w	wing area, m^2
U	aircraft speed, m/sec
W	weight, N
θ	spherical coordinate, deg
ν	kinematic viscosity, m^2/sec
ρ	air density, kg/m^3
φ	spherical coordinate, deg
ψ	wing sweep angle, deg

TEST AIRCRAFT

The aircraft used in the tests were the AeroCommander airplane, the JetStar airplane, the CV-990 airplane, and the B-747 airplane (ref. 12). The pertinent characteristics of the airplanes are presented in table 1, and three-view drawings are shown in figure 1.

The AeroCommander airplane (fig. 1(a)) is a twin-engine propeller-driven business aircraft that accommodates as many as seven passengers. It is powered by two 290 horsepower 10-540-E1B5 six-cylinder engines that drive three-bladed, constant-speed, fully feathering metal propellers that are 1.83 meters in diameter. The airplane's maximum takeoff weight is 30,030 newtons.

The JetStar aircraft (fig. 1(b)) is a four-engined, medium-range jet transport that accommodates as many as 10 passengers. The aircraft is powered by JT12A-6 turbojet engines. Its maximum takeoff weight is 186,820 newtons.

The CV-990 airplane (fig. 1(c)) is a typical long-range narrow-body jet transport. It has a maximum takeoff weight of 1,125,450 newtons. The aircraft is powered by four CJ805-23B aft turbofan engines rated at 71,170 newtons of thrust each.

The B-747 airplane (fig. 1(d)), the largest of the four aircraft, has a maximum takeoff weight of 3,158,340 newtons. The aircraft is propelled by four high-bypass-ratio JT9D turbofan engines. Each engine develops 193,500 newtons of thrust.

INSTRUMENTATION AND TEST PROCEDURES

Acoustic Data Collection

The placement of the microphone stations along the approach ground track for the AeroCommander, JetStar, and B-747 is shown in figures 2(a) and 2(b). All the microphones for these tests were mounted flush with the ground. For the CV-990 tests, both flush-mounted and tripod-mounted microphones were placed along and perpendicular to a runway on Rogers Dry Lake (fig. 2(c)).

The tripod-mounted microphones were approximately 1.2 meters above the lakebed surface. The flush-mounted microphones were shock-mounted in 0.0095-meter thick plywood boards with the microphone diaphragm flush with the board surface. The board was placed flat on the lakebed surface (fig. 3). This arrangement was used to prevent ground reflection from affecting the noise data, which makes the data difficult to interpret. The lakebed has a level, hard-packed sandy clay surface.

A typical microphone station and the signal conditioning and recording system are shown in figure 4. The station consisted of a condenser microphone with a cathode follower, amplifiers to drive the signal through a shielded two-conductor cable, and a microphone power supply. The power was supplied by batteries and an inverter.

The signal conditioning and recording system was located in a van. The signal input from each microphone station terminated at a line isolation transformer and was then routed to an amplifier and recorded on a 14-track FM magnetic tape recorder. Time of day from the time-code receiver was also recorded on the tape, permitting the recorded acoustic data to be correlated with aircraft space positioning.

The entire acoustic instrument system was calibrated electrically and acoustically. The electrical calibration consisted of introducing a 1 volt root-mean-squared signal at various frequencies from 20 hertz to 20,000 hertz to the microphone and determining any variations in the recorded signal level. An acoustic level calibration of 124 decibels at 250 hertz was applied to each microphone, and recorded, before and after each day's tests and was used in the data reduction process.

Weather Observations

A portable instrumentation tower 10 meters high was erected at the acoustic data collection station. Windspeed and direction were monitored to insure that windspeed did not exceed the 3 meter per second limit set for the tests. Ambient temperature and relative humidity were recorded for each data run and are presented in table 2. These data were used for correcting the acoustic data to standard day conditions in accordance with FAR Part 36 (ref. 3).

Radar Tracking

A ground-based fixed-pedestal tracking radar (FPS-16) was used to provide glide slope information and to correlate the aircraft position with the noise data. To aid in tracking, a C-band radar transponder was installed on each airplane tested. The time of day and radar data were recorded on magnetic tape for later processing. The radar data were also displayed on a plot board in the control room to provide glide slope and tracking information to a flight controller. The controller supplied glide slope and ground track deviation information to the pilot.

Aircraft Onboard Instrumentation

Data descriptive of the aircraft operating conditions during each approach were read from cockpit instruments. These included airspeed, engine rpm, fuel quantity, and flap and landing gear positions. The airplane gross weight over the microphones was determined for each approach from the airplane's empty weight and fuel weight. Table 2 shows the pertinent aircraft parameters for each test point.

DATA REDUCTION AND ANALYSIS

The recorded radar tracking data were processed to relate the aircraft position with respect to time to each microphone location. The distance between the airplane and the microphone was later used to make atmospheric absorption corrections to the noise measurements.

The acoustic data were processed with a real-time one-third octave band analyzer that met the FAR Part 36 specifications for equipment used to analyze noise data. The time constant used for the data analysis was 1 second. Calibration corrections were applied, and the data were corrected to standard day conditions by using the procedure described in reference 3. The data were scaled to other than the measurement distances by applying the inverse square of the distance and standard day atmospheric absorption corrections. Overall sound pressure level (OASPL) and perceived noise level (PNL) were calculated from the one-third octave band spectra. The data from the flush-mounted microphones were not corrected for the sound pressure doubling effects inherent in such data, and the tripod-mounted data retained ground reflection effects (ref. 13).

FLIGHT PROCEDURE

Ideally, airframe noise would be measured during landing approaches flown with the airplane's engines turned off. This is risky, however, since at landing speeds and altitudes an aircraft is committed to a landing if the engines are off. In addition, hydraulic power is required to maintain control of the larger aircraft. Therefore, the only configuration tested with the engines off was the landing-gear-down configuration, and then only with the AeroCommander and JetStar aircraft.

All the tests of the larger aircraft (CV-990 and B-747) and the landing-gear-up configurations of the smaller aircraft were tested with the engines at idle power.

The procedure used to fly over the microphone array was the same for the AeroCommander, JetStar, and CV-990 airplanes. The glide slope that allowed the airplane to maintain the desired airspeed was computed. This resulted in glide slopes between 3° and 9° , depending on the airplane, its configuration, and the airspeed desired. The altitude desired for the aircraft over the center of the microphone array was 152 meters. When the aircraft was approximately 10 seconds from the first microphone position, the pilot turned the engines off or brought them to idle. After the aircraft passed the microphone array, the pilot either landed the aircraft (if the engines were off) or applied thrust (if the engines were at idle). The thrust was applied approximately 10 seconds after the airplane passed over the microphones or when it descended below an altitude of approximately 30 meters above ground level, whichever occurred first.

The procedure used to set up the desired glide slope for the B-747 airplane was somewhat different, because the aircraft was primarily engaged in another test program. The pilot used the onboard instrument landing system for runway alignment, and he estimated that a glide slope of approximately 4° would bring the aircraft over the center microphone in the desired configuration at an altitude of 152 meters. This technique resulted in aircraft altitude variations over the microphone array of between 91.4 meters and 182 meters for the B-747 test data. The engines were reduced to idle thrust approximately 10 seconds before the airplane passed over the microphones, and thrust was applied when the aircraft descended below 61 meters.

RESULTS AND DISCUSSION

Results of the airframe noise of the three jet-powered aircraft, the B-747, CV-990, and JetStar, are presented first for the landing-gear-up configuration and then for the landing-gear-down configuration. All results, unless noted, were obtained with flush-mounted ground microphones.

Landing Gear Up

The overall sound pressure levels for the three jet aircraft with gear up were normalized to an altitude of 152 meters and plotted as a function of airspeed in figure 5. Data are shown for flaps extended and retracted. For reference purposes, lines have been drawn that represent the OASPL calculated using the fifth power of the airspeed of each aircraft.

The same data from the three jet aircraft in the clean configuration are shown in figure 6 (open symbols) normalized to an aircraft weight of 155,680 newtons. The OASPL's of all three jet aircraft exhibit a fifth-power dependence on aircraft airspeed when calculated using the equation below:

$$\text{OASPL} = 10 \log U^5 + 10 \log W - 74.0 \quad (1)$$

where U is aircraft speed and W is aircraft weight. The data in figure 6, which were used to develop equation (1), cover a range of aircraft speeds from 97.2 meters per second to 187.8 meters per second. Aircraft weight varied from 148,118 newtons for the JetStar airplane to approximately 2,233,000 newtons for the B-747 airplane. Since the data for all three aircraft are in close agreement with equation (1), it is suggested that the details of aircraft configuration are not of great significance in the generation of airframe noise in the clean configuration.

Only three OASPL measurements were made with the wing trailing-edge flaps extended and the gear up (fig. 6, solid symbols). No attempt is made to correlate the noise data, since the flap deflections were different for each airplane (50° for the JetStar airplane, 36° for the CV-990 airplane, and 25° for the B-747 airplane). But it can be seen that with flaps extended there is an additional noise of at least 7 decibels above the clean configuration.

Curle (ref. 14) has shown that whenever a surface is immersed in turbulent flow, the far-field sound pressure that is generated is related to the fluctuating force acting on the surface. The intensity of the sound pressure depends upon a characteristic velocity over the surface to approximately the sixth power. Powell's subsequent theoretical analysis of aerodynamic noise (ref. 15) indicates that the sound pressure has approximately a fifth-power dependence on velocity and is related to effective plate area. Powell's theory has been amplified by Ffowcs Williams and Hall (ref. 16), who also show a fifth-power dependence on velocity.

The physical concepts developed in references 15 and 16 governing edge-noise generation can be extended to explain the mechanism of airframe-noise generation by an aircraft with landing gear up. Equation (1), the dependence of OASPL on the fifth power of aircraft velocity, closely agrees with their theory. The correlation of the OASPL with aircraft weight is needed only to the extent that the weight is proportional to the effective area of the noise-generating region, as shown in Powell's analysis.

Hersh (ref. 10) expanded on the theory from Ffowcs Williams and Hall to develop the following equation for the prediction of airframe noise for an airplane in the clean configuration:

$$\text{OASPL} = 10 \log \frac{K_w C_{D_w} \rho^2 U^{4.8} S_w \cos^2 \left(\frac{\theta}{2} \right) \sin \varphi \cos^2 \psi}{p_{ref}^2 (\bar{c}/v)^{0.2} aR^2}$$

where R , θ , and φ are spherical coordinates defined as shown in figure 7.

This equation shows that the sound pressure radiated from the wing has a 4.8 power dependence on aircraft velocity and is linearly proportional to the drag coefficient for the wing and wing area. The acoustic constants, K_w and K_{wf} , represent the average edge-scattering noise for flaps retracted and extended, respectively, and are independent of aircraft weight and speed. The value of K_w was calculated from the data in figure 6, which are shown again in figure 8(a). The average value of $10 \log K_w$ was -29.2 decibels. Individual values differed by less than 1 decibel from the average. For the flaps-extended configuration, K_{wf} should be substituted for K_w . As previously stated, only three OASPL measurements were available with the trailing-edge flaps extended in the gear-up configuration. The three values for $\log K_{wf}$ averaged -24.5 decibels and differed by less than 1 decibel from their average despite the differences in flap deflection.

The peak one-third octave band sound pressure level (SPL) spectra for the JetStar, CV-990, and B-747 airplanes in the clean configuration are shown in figures 9(a), 9(b), and 9(c), respectively. For the JetStar airplane (fig. 9(a)), the lowest spectrum is an estimate of the engine-idle noise computed from static engine measurements. The spectrum for a speed of 128.6 meters per second is made up of engine-idle noise and airframe noise. At this speed the idling engines are a major contributor of noise. For JetStar speeds of 155.4 meters per second and above, airframe noise is dominant, since the engine-idle noise does not increase with the airplane speed.

Engine-idle noise is not believed to contribute to the SPL spectra for the CV-990 and B-747 aircraft (figs. 9(b) and 9(c)). Static measurements were not available for either airplane to confirm the level of the engine-idle noise. For the low speed B-747 spectrum, the peak that occurs between 160 and 200 hertz is believed to be due to some phenomenon other than airframe noise.

Shown in figure 10 are the SPL spectra of the JetStar airplane from figure 9(a) normalized with respect to OASPL. The spectrum shape and its maximum frequency (peak) do not change as speed increases.

When the five normalized JetStar spectra in figure 10 are averaged, they take the form shown in figure 11. The one-third octave band SPL spectra for the CV-990 and B-747 airplanes in the clean configuration were also normalized with respect to OASPL and averaged. As figure 11 shows, the spectra for all three aircraft are similar in shape and peak at approximately 1250 hertz. As previously discussed, this peak is independent of aircraft speed; it also seems to be independent of aircraft size, although the width of the spectra appears to increase with increasing airplane size. A secondary peak in the spectra occurs between 100 hertz and 250 hertz. The double spectral peak suggests the existence of two airframe noise generating mechanisms. However, further research and analysis will be necessary to confirm this.

Figure 12 compares the measured spectrum for the JetStar in the clean configuration with the spectrum predicted using the nondimensional technique developed by Healy (ref. 4). The measured spectrum is an average of the spectra measured for speeds from 128.6 meters per second to 187.8 meters per second. (It is repeated from fig. 11.) As figure 12 shows, the measured and predicted spectra agree in only a general sense. The prediction technique is based on the assumption that there is one source of noise, whereas the present data indicate that there may be at least two. It is apparent that additional research will be necessary to develop a universal nondimensional spectrum for the prediction of clean configuration airframe noise.

Landing Gear Down

The description of airframe noise for aircraft with the landing gear down is difficult. Predominant noise sources when the gear are down are the supporting struts, wheels, doors, and wheel wells. The interaction between any of the above with each other and with the wing and flaps may create additional noise. The relative importance of the various noise sources with the gear down has not been assessed because no adequate physical model of each of the components has been developed.

The variation of OASPL with airplane velocity for the landing-gear-down configuration is shown in figure 13. The solid symbols denote flaps retracted; the open symbols denote flaps extended. The figure also shows OASPL as calculated using the fifth power of aircraft speed. The JetStar, CV-990, and AeroCommander data exhibit a fifth-power dependence on aircraft speed. The B-747 data do not exhibit this dependence; however, only two data points were available, and for one the flaps were retracted and for the other the flaps were extended.

Hersh (ref. 10) has characterized the acoustic noise from the wheels and struts as of the dipole type, determining that the OASPL should have a sixth-power dependence on aircraft speed. It was not possible to evaluate this suggestion with the data presented here. First, the flaps are significant noise sources when extended as shown in figures 5 and 6; the propellers of the AeroCommander are also possible noise sources. Therefore, in the flaps-extended data and the AeroCommander data the OASPL dependence on the fifth power of the airspeed predominates, and it was not possible to evaluate landing gear noise dependence on airspeed. Furthermore, only seven data points were obtained with flaps retracted and gear down: three for the AeroCommander, three for the JetStar, and one for the B-747 airplane.

The magnitude of the noise in the landing configuration (open symbols, fig. 13) is not strictly related to airplane weight. The JetStar with landing gear down and flaps extended is approximately six times as heavy as the AeroCommander airplane, and it makes approximately 4 decibels more noise. The CV-990 airplane is approximately five times as heavy as the JetStar airplane, and its noise level is almost 7 decibels greater than that of the JetStar airplane. This indicates that the airframe noise of an airplane in the landing configuration depends on the details of the aircraft design. Therefore, the addition of a simple additive constant to equation (1), which calculates the airframe noise level for the clean configuration, will not result in the correct noise level for the landing configuration.

The airframe noise spectra for the four aircraft in the landing configuration are shown in figure 14. The JetStar and CV-990 spectra were measured for an aircraft speed of 82.3 meters per second. The B-747 and AeroCommander spectra were measured for a speed of 104.8 meters per second and 58.1 meters per second, respectively, and were scaled to 82.3 meters per second by assuming that the spectral shape remained constant and that the spectral level increased with the fifth power of airplane velocity. All four spectra in figure 14 are similar in shape and have no easily identifiable characteristics except for being broadband and approximately constant in amplitude between 100 hertz and 1000 hertz. These spectra do not suggest a dominant noise source; indeed, the spectra probably result from several noise sources.

To assess the relative importance of airframe noise, the effective perceived airframe noise levels for the JetStar and CV-990 aircraft were calculated and adjusted to the conditions specified in FAR Part 36. The landing configuration airframe noise levels are compared in figure 15 with the approach noise criterion specified in FAR Part 36. Also shown is an envelope of airframe noise data which was derived from B-747 and B-727 airframe noise measurements reported in reference 2. The airframe noise levels for all aircraft are approximately 10 EPNdB below the present certification limits. Therefore, airframe noise as well as propulsion system noise will have to be reduced if total airplane noise during landing approach is to be significantly reduced.

Slant Range Effects

The variation of airframe noise with slant range is illustrated in figure 16 for the CV-990 airplane. Both the clean and landing configurations are shown. Data from the flush-mounted microphones located along the ground track are presented along with data from a line of tripod-mounted microphones located perpendicular to the ground track at distances up to 450 meters. The data for noise along the ground track agree with the inverse square law for both the clean and landing configurations for distances up to 200 meters. The data for airframe noise measured perpendicular to the ground track appear to deviate somewhat from the inverse square law. This is due, in part, to the effects of the additional ground attenuation and ground reflection due to distance from the ground track.

SUMMARY OF RESULTS

Flight tests were conducted to measure the airframe noise signatures of the AeroCommander, JetStar, CV-990, and B-747 aircraft. The aircraft were tested in various landing approach configurations. The overall sound pressure levels of flyover noise data were compared with existing equations for predicting airframe noise levels. The analyses show that:

The level of airframe noise for the JetStar, CV-990, and B-747 aircraft with landing gear up varied with approximately the fifth power of airspeed. For these airplanes in the clean configuration, an empirical equation based on aircraft speed and weight accurately predicted the airframe noise levels. The accuracy of an

equation developed by Hersh was also demonstrated using the noise data. The Hersh equation predicted airframe noise with flaps extended as well as retracted in the gear-up configuration.

The airframe noise level of all four test aircraft in the landing configuration also varied like the fifth power of the airspeed, but the airframe noise level appeared to depend primarily on the details of aircraft design. The addition of a simple additive constant to the equation for the clean-configuration airframe noise level did not give a test airplane's correct landing-configuration noise level.

The clean-configuration airframe noise spectra exhibited two peaks, suggesting the existence of two noise-generating mechanisms. The landing-configuration airframe noise spectra were broadband and approximately constant in amplitude between 100 hertz and 1000 hertz.

The effective perceived noise levels of the JetStar and CV-990 in the landing configuration are approximately 10 decibels below current FAR Part 36 landing approach certification levels.

Airframe noise along the ground track for the CV-990 varies with the inverse square law, but airframe noise measured at locations perpendicular to the ground track deviates somewhat from the inverse square law, probably because of the effects of ground attenuation and ground reflection.

*Dryden Flight Research Center
National Aeronautics and Space Administration
Edwards, Calif., May 11, 1979*

REFERENCES

1. Lasagna, P. L.; and Putnam, T. W.: Preliminary Measurements of Aircraft Aerodynamic Noise. AIAA Paper 74-572, June 1974.
2. Blumenthal, V. L.; Streckenbach, J. M.; and Tate, R. B.: Aircraft Environmental Problems. AIAA Paper 73-5, Jan. 1973.
3. Federal Aviation Regulations. Part 36—Noise Standards: Aircraft Type Certification, Appendix B. Fed. Aviation Admin., Dec. 1969.
4. Healy, Gerald J.: Measurement and Analysis of Aircraft Far-Field Aerodynamic Noise. NASA CR-2377, 1974.
5. Burley, Richard R.: Preliminary Measurement of the Airframe Noise from an F-106B Delta Wing Aircraft at Low Flyover Speeds. NASA TM X-71527, 1974.
6. Gibson, John S.: Non-Engine Aerodynamic Noise Investigation of a Large Aircraft. NASA CR-2378, 1974.
7. Hardin, Jay C.; Fratello, David J.; Hayden, Richard E.; Kadman, Yoran; and Africk, Steven: Prediction of Airframe Noise. NASA TN D-7821, 1975.
8. Revell, J. D.: The Calculation of Aerodynamic Noise Generated by Large Aircraft at Landing Approach. J. Acoust. Soc. Am., vol. 55, Suppl., Spr. 1974, p. S73.
9. Fink, M. R.: Airframe Noise Prediction Method. FAA-RD-77-29, Fed. Aviation Admin., Mar. 1977.
10. Hersh, Alan S.; Burcham, Frank W., Jr.; Putnam, Terrill W.; and Lasagna, Paul L.: Semiempirical Airframe Noise Prediction Model and Evaluation With Flight Data. NASA TM X-56041, 1976.
11. Putnam, Terrill W.; Lasagna, Paul L.; and White, Kenneth C.: Measurements and Analysis of Aircraft Airframe Noise. AIAA Paper 75-510, Mar. 1975.
12. Taylor, John W. R., ed.: Jane's All the World's Aircraft, 1973-1974. McGraw-Hill Book Co., 1973.
13. Howes, Walton L.: Ground Reflection of Jet Noise. NASA TR R-35, 1959.
14. Curle, N.: The influence of solid boundaries upon aerodynamic sound. Proc. Roy. Soc. (London), ser. A, vol. 231, 1955, pp. 505-513.

15. Powell, Alan: On the Aerodynamic Noise of a Rigid Flat Plate Moving at Zero Incidence. *J. Acoust. Soc. America*, vol. 31, no. 12, Dec. 1959, pp. 1649-1653.
16. Ffowcs Williams, J. E.; and Hall, L. H.: Aerodynamic sound generation by turbulent flow in the vicinity of a scattering half plane. *J. Fluid Mech.*, vol. 40, part 4, Mar. 9, 1970, pp. 657-670.

TABLE 1.—TEST AIRPLANE DIMENSIONS AND WEIGHTS

	AeroCommander	JetStar	CV-990	B-747
Wing span, m	14.95	16.60	36.58	59.64
Overall length, m	11.15	18.4	42.43	70.51
Height, m	4.42	6.23	12.04	19.33
Wing area, m ²	23.7	50.4	209	511
Mean aerodynamic chord, m	1.58	3.04	5.47	8.32
Aspect ratio	9.45	5.27	6.2	6.96
Sweep angle, deg	-----	30	35	37.7
Maximum weight, N—				
Takeoff	30,030	186,820	1,125,450	3,158,340
Landing	30,030	155,680	889,690	2,508,880

TABLE 2.—OPERATING CONDITIONS AND CONFIGURATIONS

(a) Landing gear up

Airplane	Flap setting, deg	W, N	U, m/sec	OASPL, dB	Ambient temperature, °C	Relative humidity, percent
JetStar	0	161,020	128.6	84.5	1.7	43
	0	158,350	155.4	87.1	1.7	43
	0	155,680	177.5	90.2	1.7	43
	0	151,230	182.7	90.4	1.7	43
	0	148,120	187.8	91.0	1.7	43
	50	140,272	87.5	87.3	1.7	43
CV-990	0	696,340	97.2	86.1	.4	55
	0	809,540	161.0	93.9	-3.9	79
	36	738,000	97.7	92.8	-1.1	58
B-747	0	2,228,000	120.2	92.8	25.1	31
	0	2,233,000	139.5	95.0	27.7	30
	25	2,255,000	105.4	99.0	25.1	30

(b) Landing gear down

Airplane	Flap setting, deg	W, N	U, m/sec	OASPL, dB	Ambient temperature, °C	Relative humidity, percent
JetStar	0	137,940	93.6	87.3	1.7	43
	0	135,160	103.4	88.9	1.7	43
	0	131,150	104.9	88.4	1.7	43
	50	135,660	70.5	82.9	1.7	43
	50	132,040	81.2	86.8	25.2	24
	50	123,210	82.3	86.0	8.9	52
	50	125,880	90.5	87.1	27.7	22
	CV 990	36	749,490	82.3	92.7	-2.2
	36	738,340	102.4	97.2	2.2	56
B 747	0	2,277,000	114.5	101.1	27.7	32
	25	2,211,000	104.8	101.8	25.0	36
AeroCommander	0	28,894	57.6	74.1	-8.3	77
	0	28,779	59.1	74.9	-8.3	77
	0	28,645	78.7	79.5	-8.3	77
	Down	29,259	59.7	74.6	-8.3	77
	Down	29,206	58.1	72.3	-8.3	77

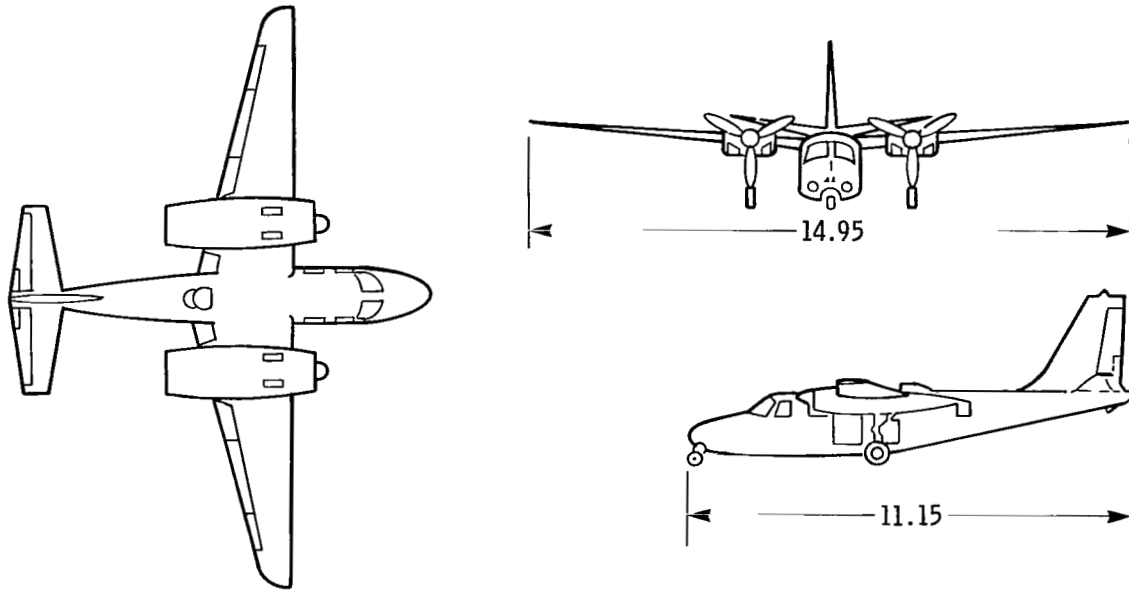

(a) AeroCommander.

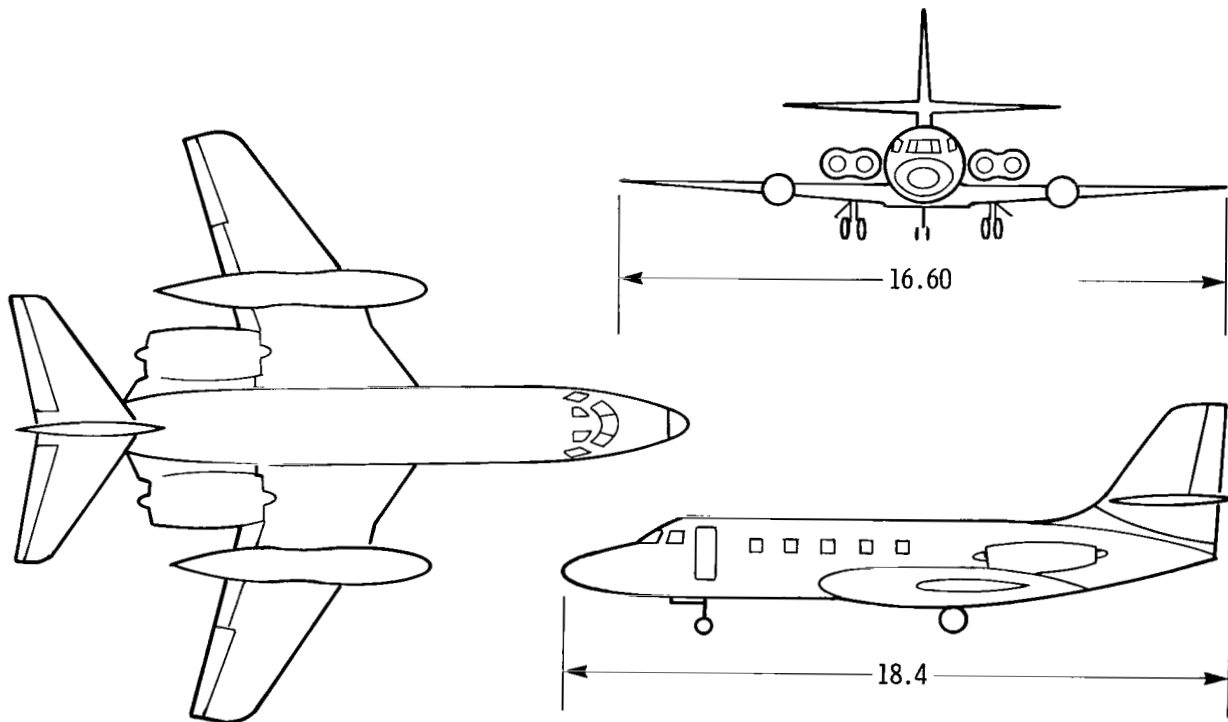

(b) JetStar.

Figure 1. Three-view drawings of airplanes tested.
Dimensions in meters.

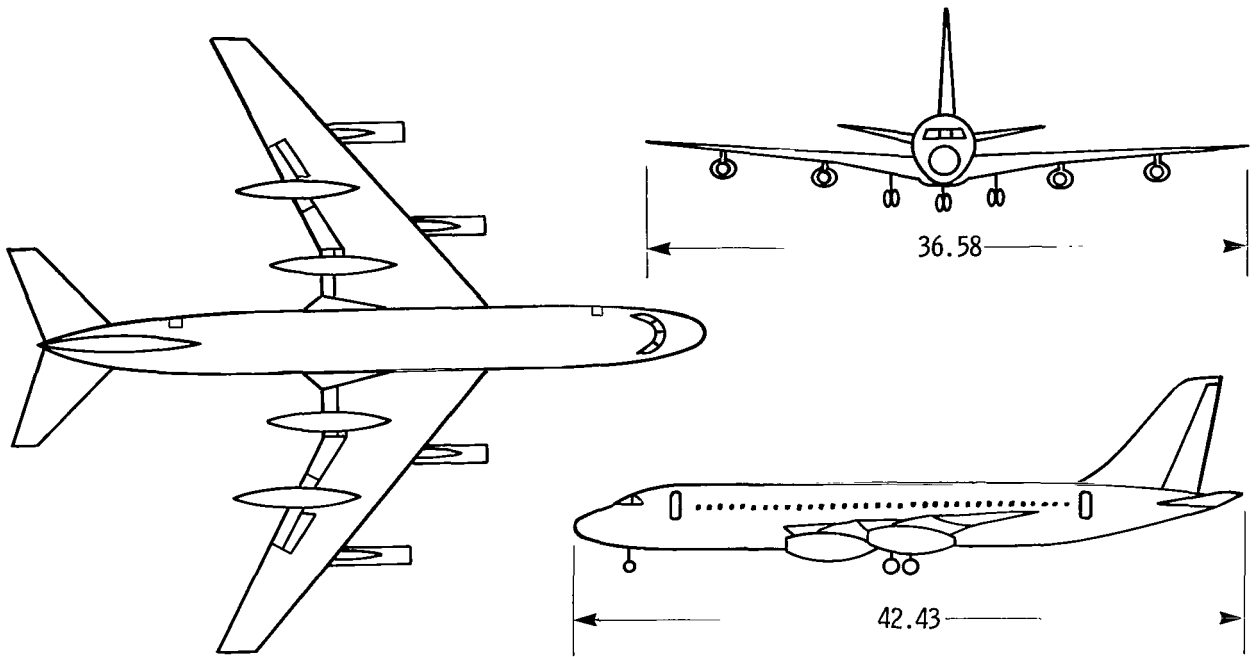

(c) CV-990.

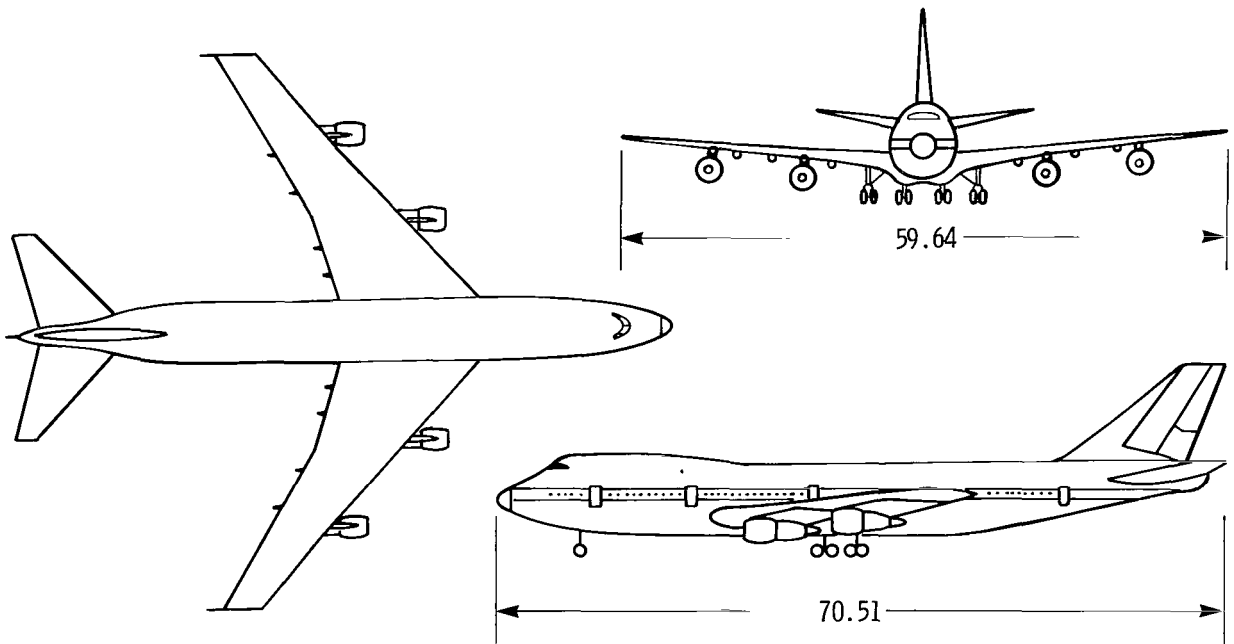

(d) B-747.

Figure 1. Concluded.

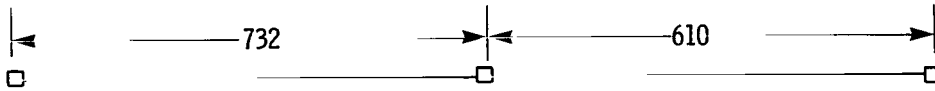

(a) AeroCommander and JetStar. All microphones are flush mounted.

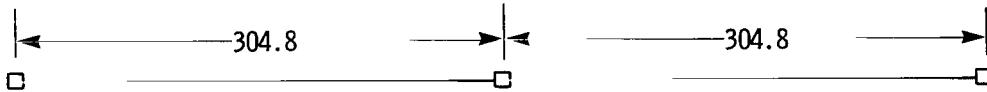

(b) B-747. All microphones are flush mounted.

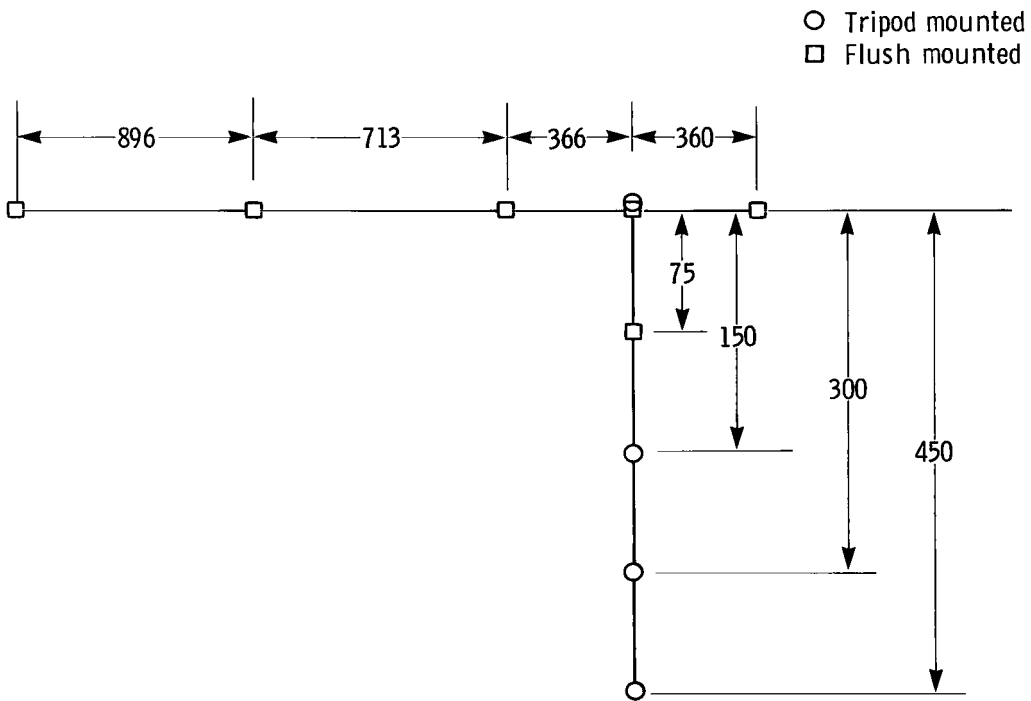

(c) CV-990.

Figure 2. Microphone layouts for the four aircraft flight tested. Dimensions in meters.

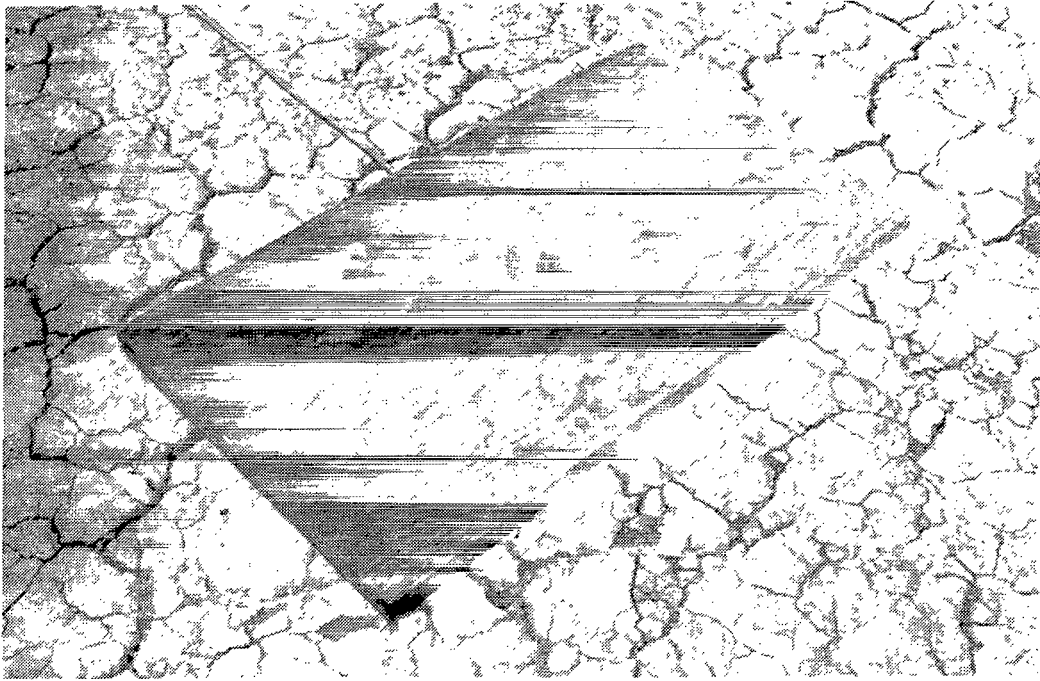

E 30622

Figure 3. Flush-mounted microphone as placed on lakebed surface.

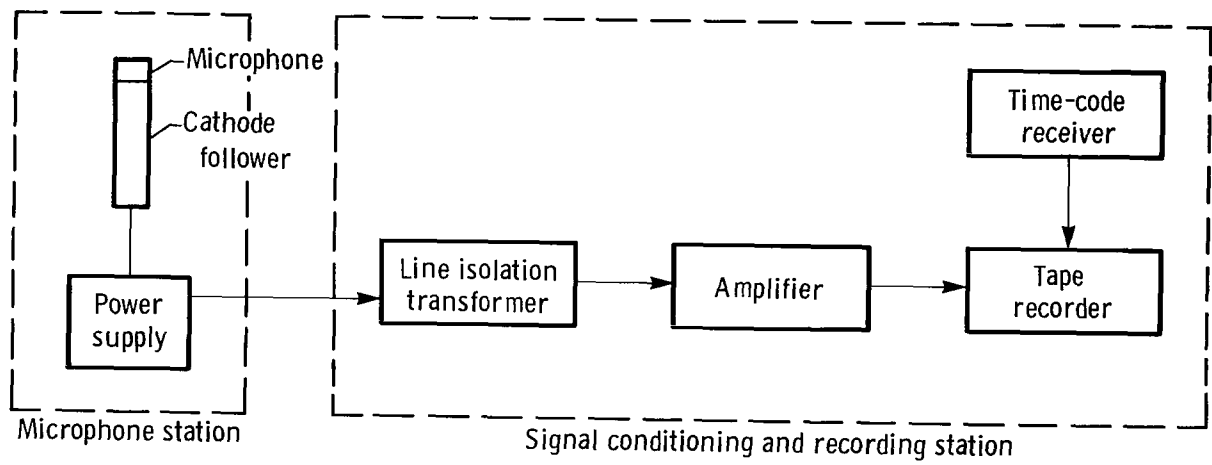

Figure 4. Relationship of microphone station to signal conditioning and recording station.

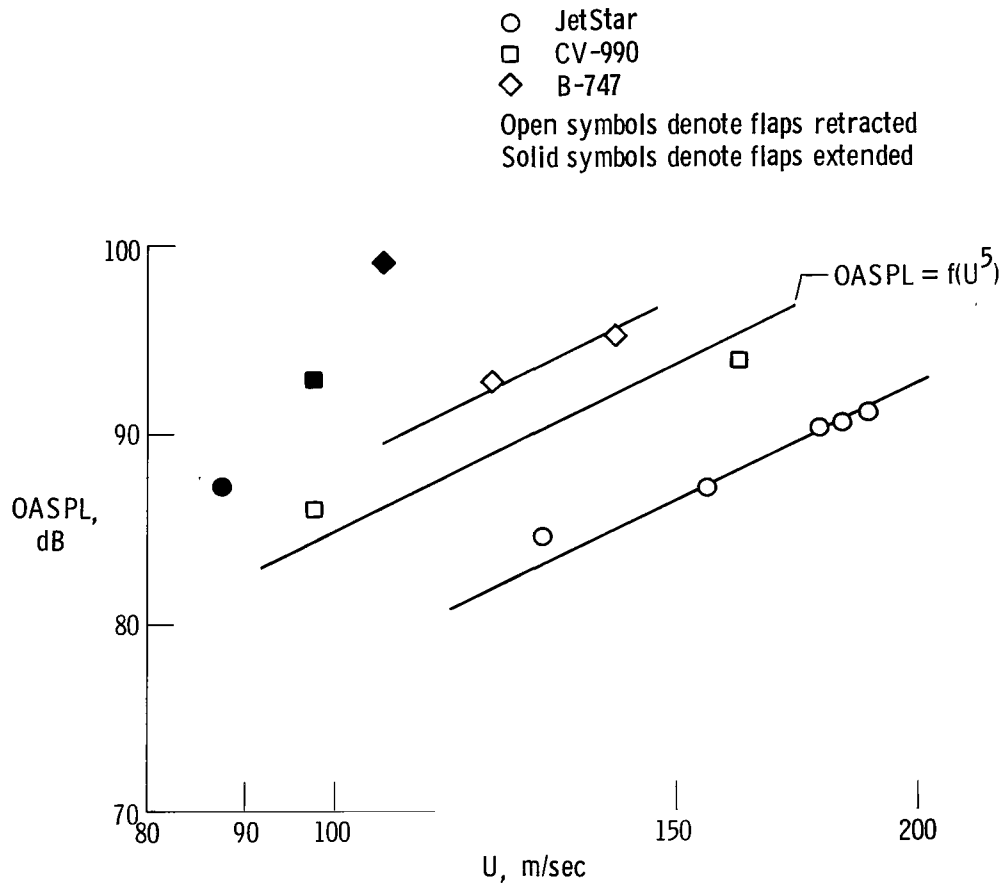

Figure 5. Variation of airframe noise with airspeed for the jet aircraft in landing-gear-up configuration. Data are normalized to an altitude of 152 meters.

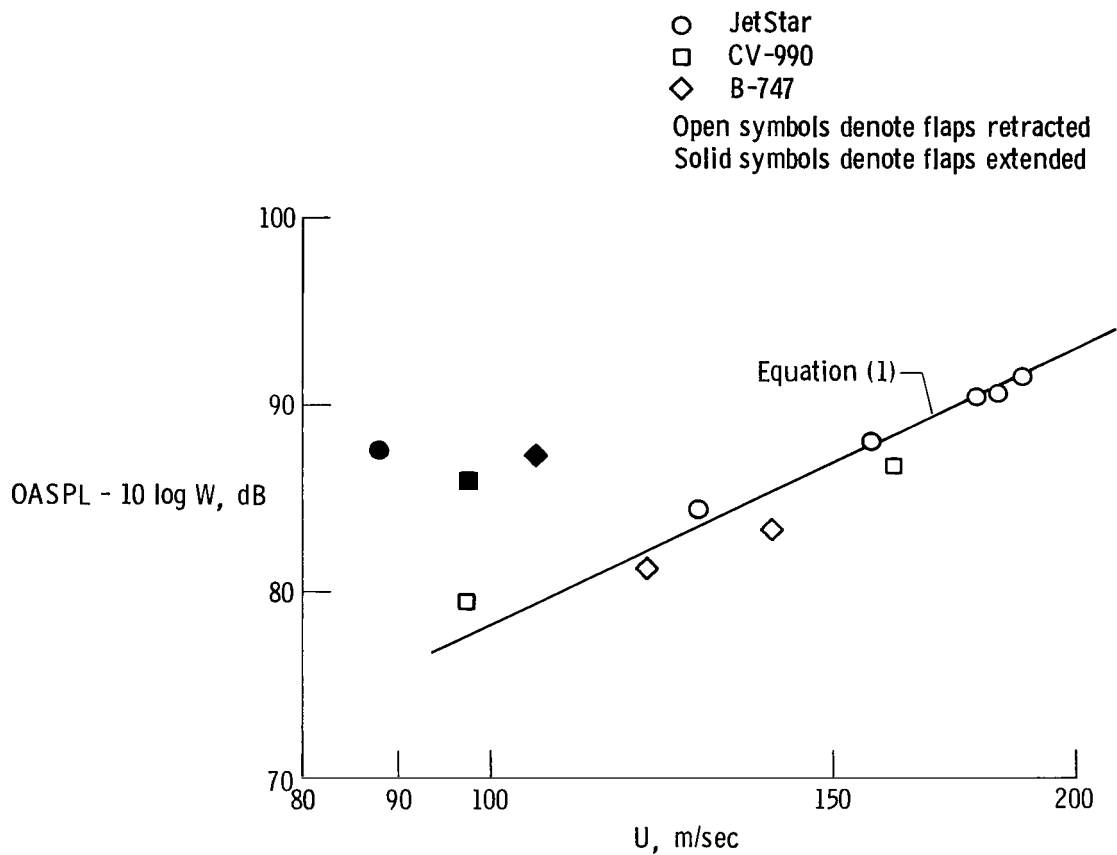

Figure 6. Variation of airframe noise with airspeed for the jet aircraft in the landing-gear-up configuration. Data are normalized to a weight of 155,680 newtons and an altitude of 152 meters.

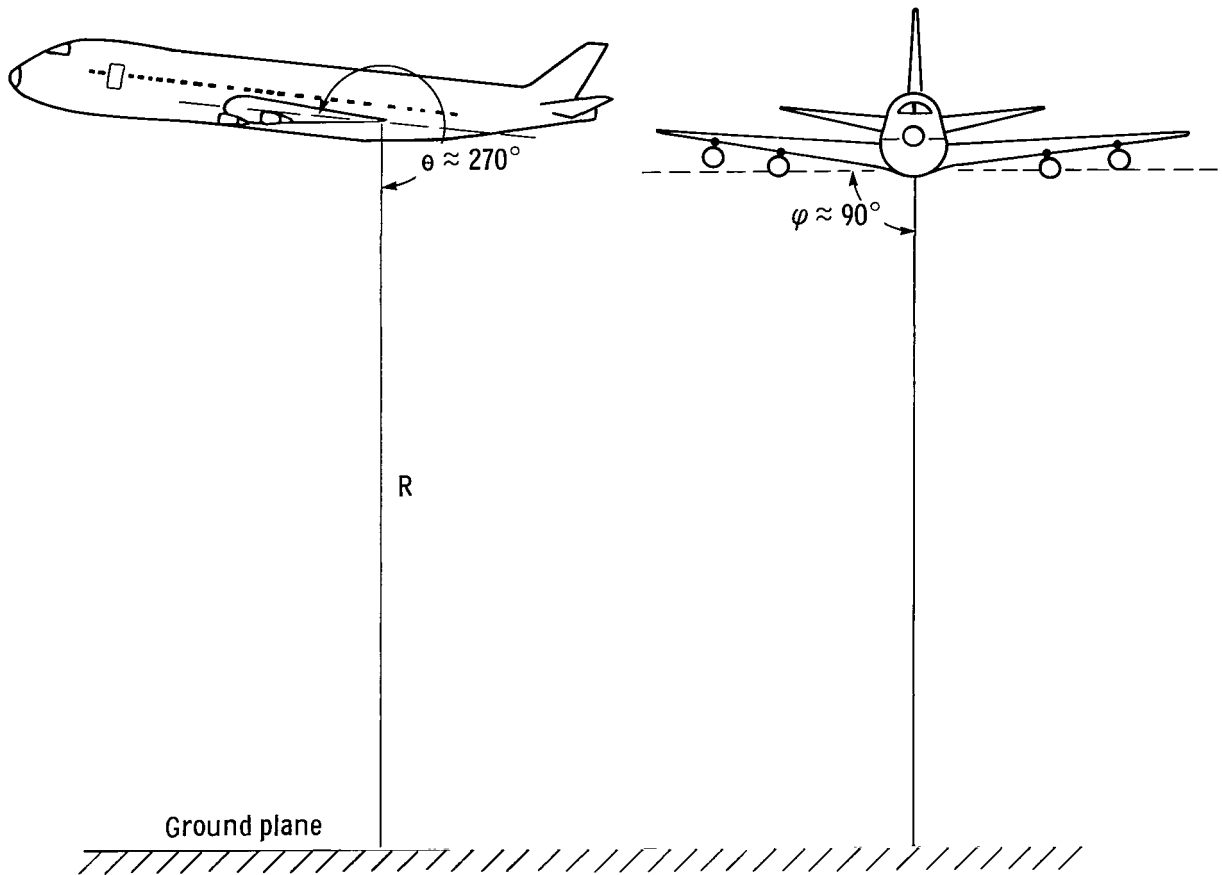
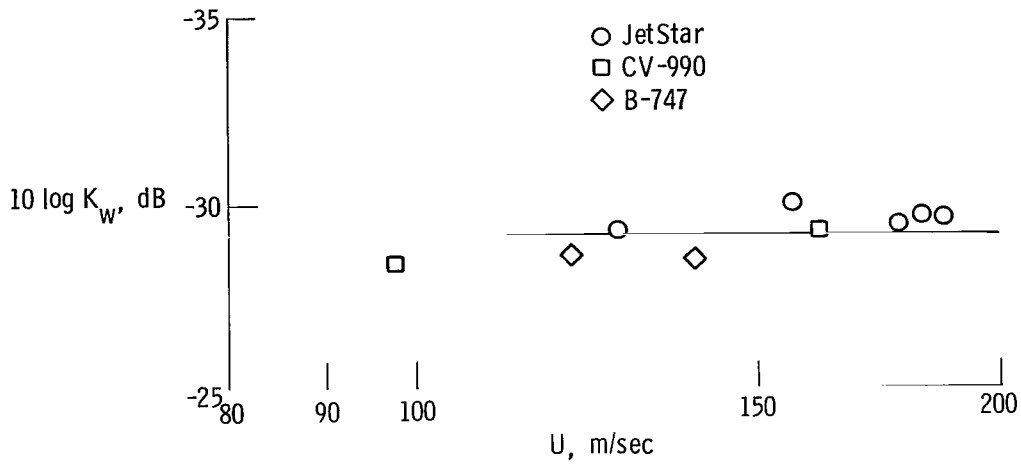
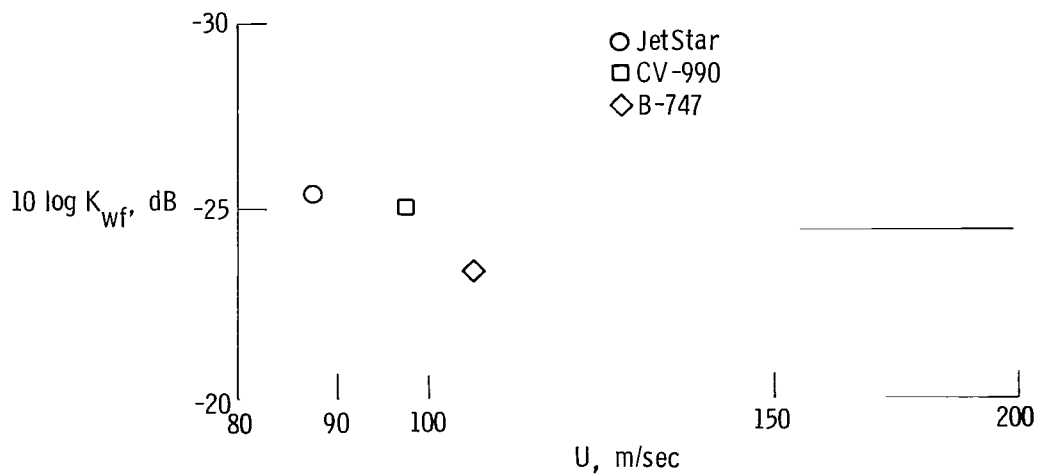

Figure 7. Direction of angles for quadrupole trailing-edge diffracted noise sources.



(a) Flaps retracted.



(b) Flaps extended.

Figure 8. Evaluation of acoustic constants for Hersh's equation with flaps retracted and extended. Landing gear up.

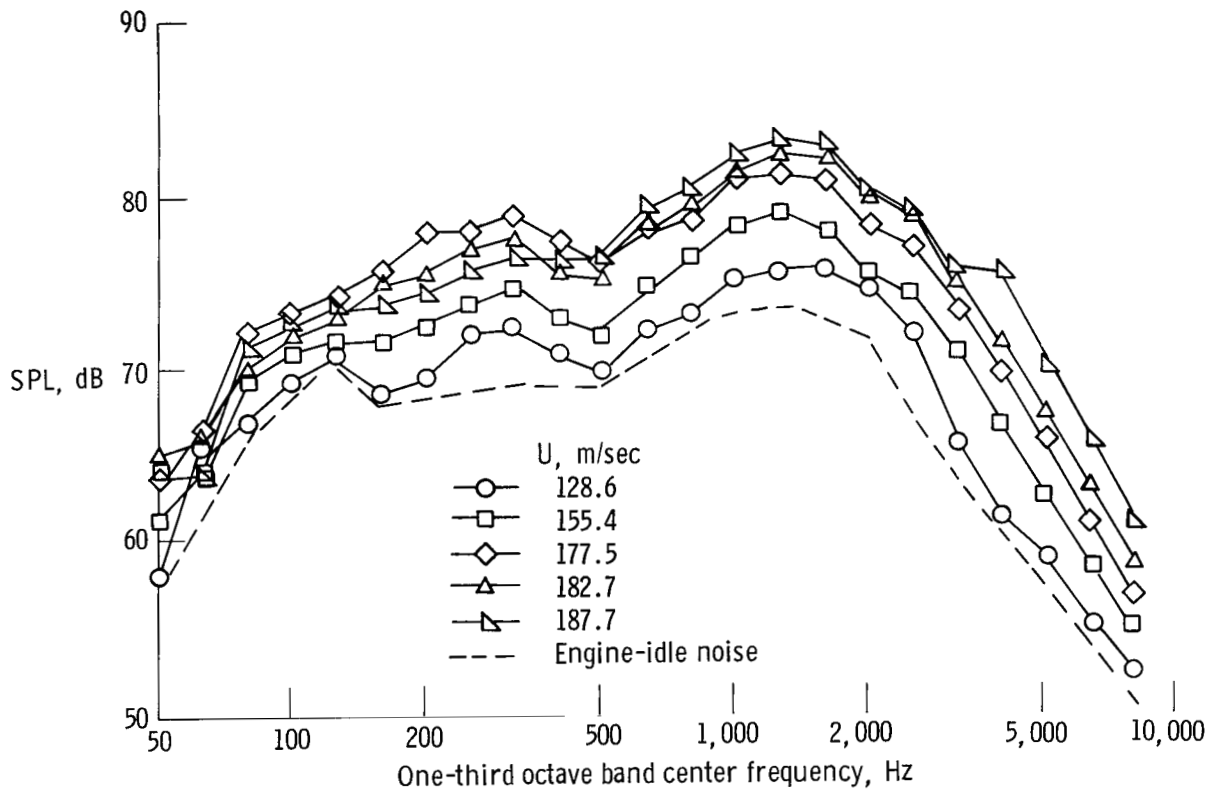

(a) JetStar.

Figure 9. Airframe-noise spectra for test aircraft in the clean configuration.

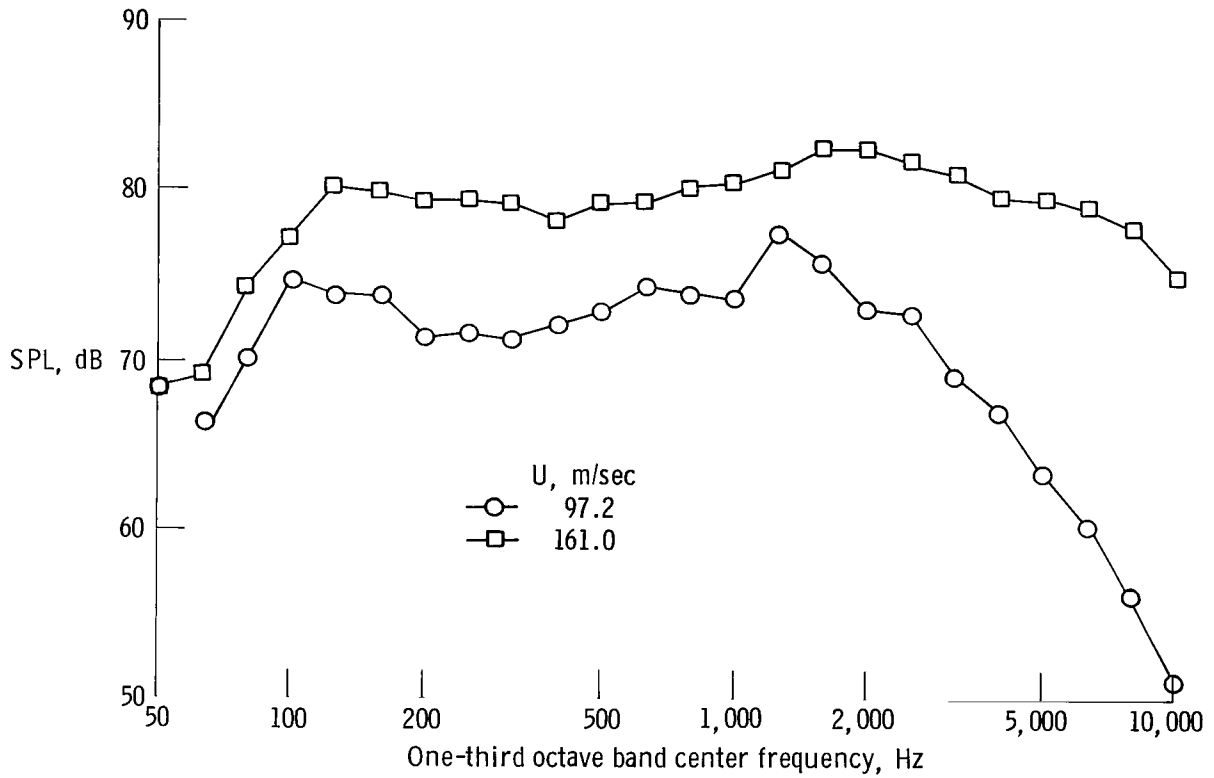

(b) CV-990.

Figure 9. Continued.

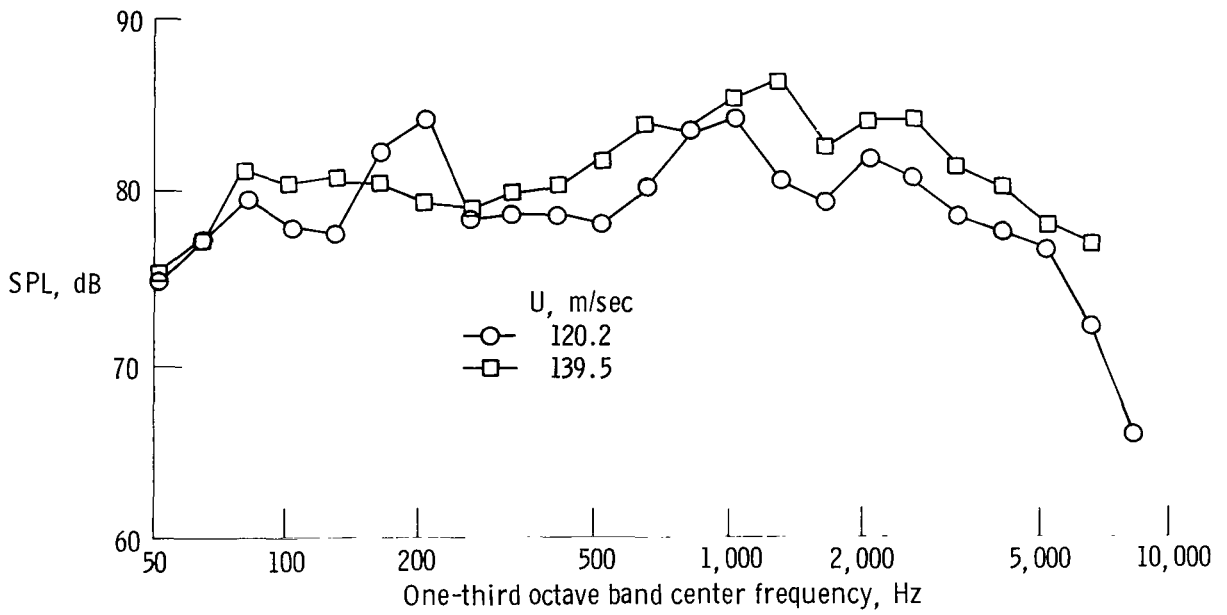

(c) B-747.

Figure 9. Concluded.

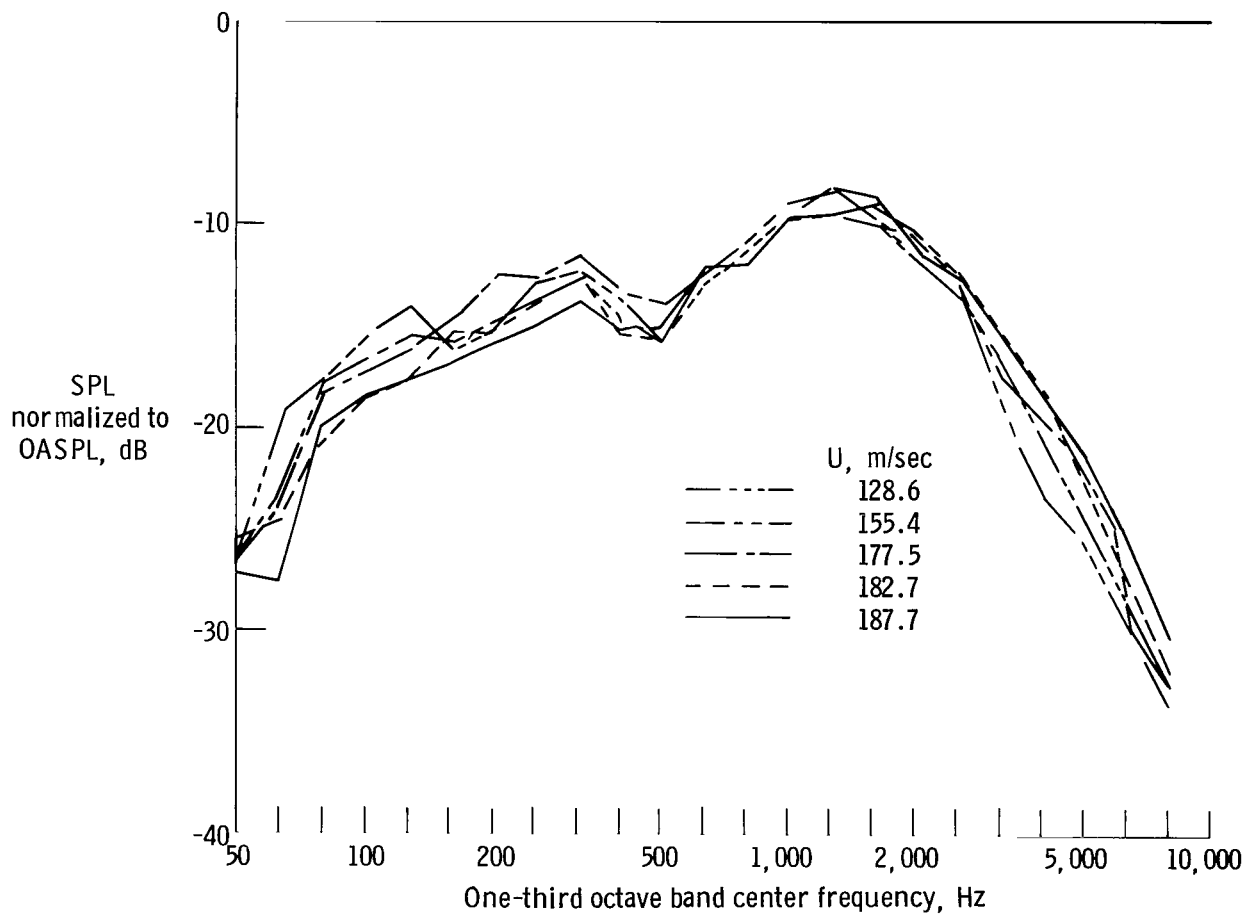

Figure 10. Normalized airframe-noise spectra for the JetStar airplane in the clean configuration.

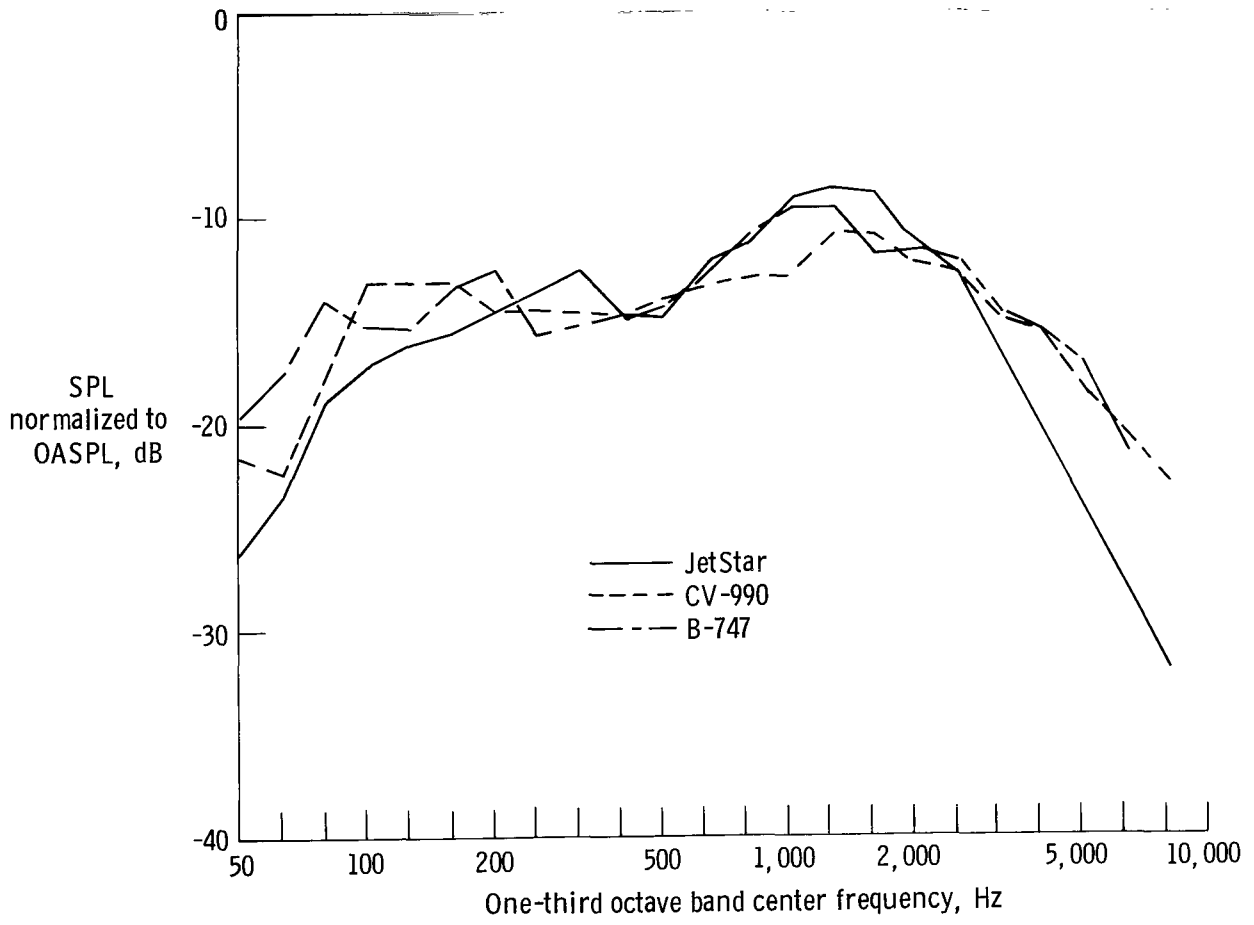

Figure 11. Normalized airframe-noise spectra averages for JetStar, CV-990, and B-747 airplanes in clean configuration.

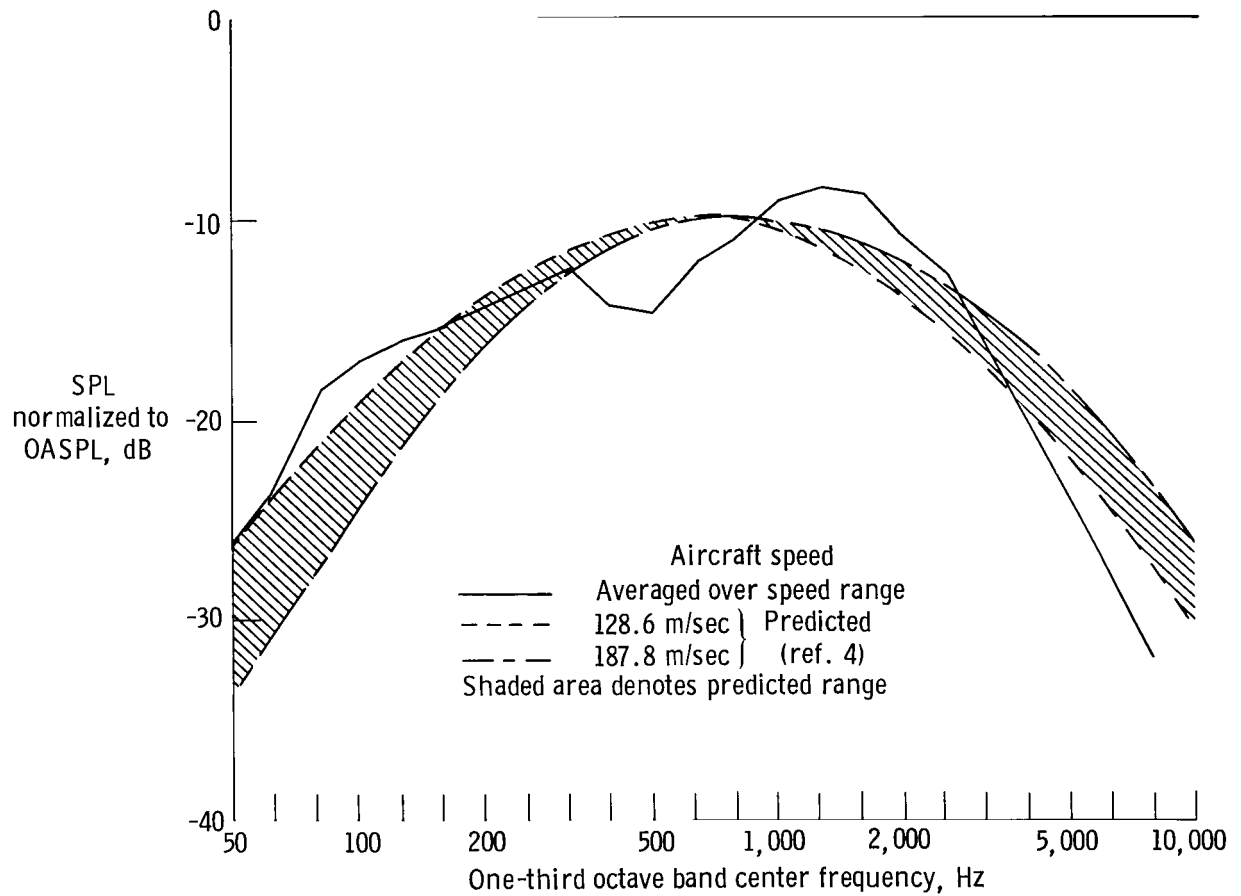

Figure 12. Comparison of measured with predicted spectra for JetStar airplane in clean configuration.

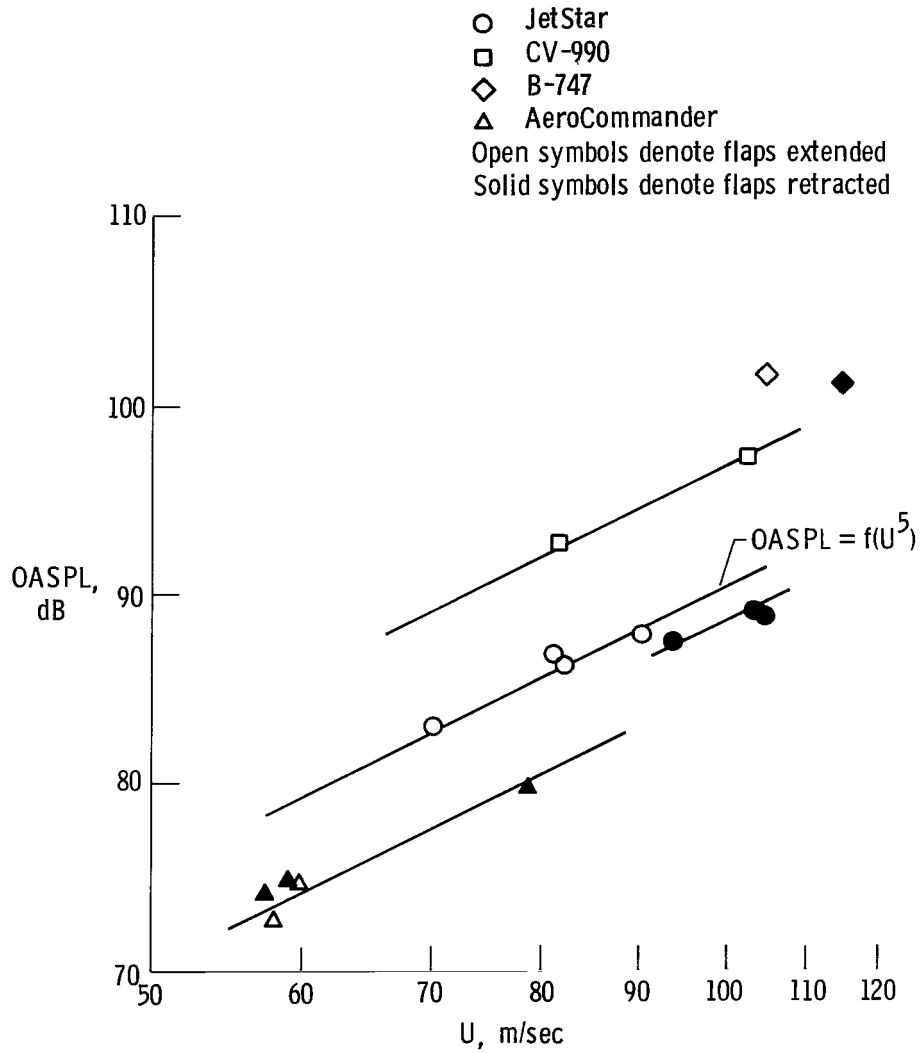

Figure 13. Airframe noise levels in the landing-gear-down configuration.

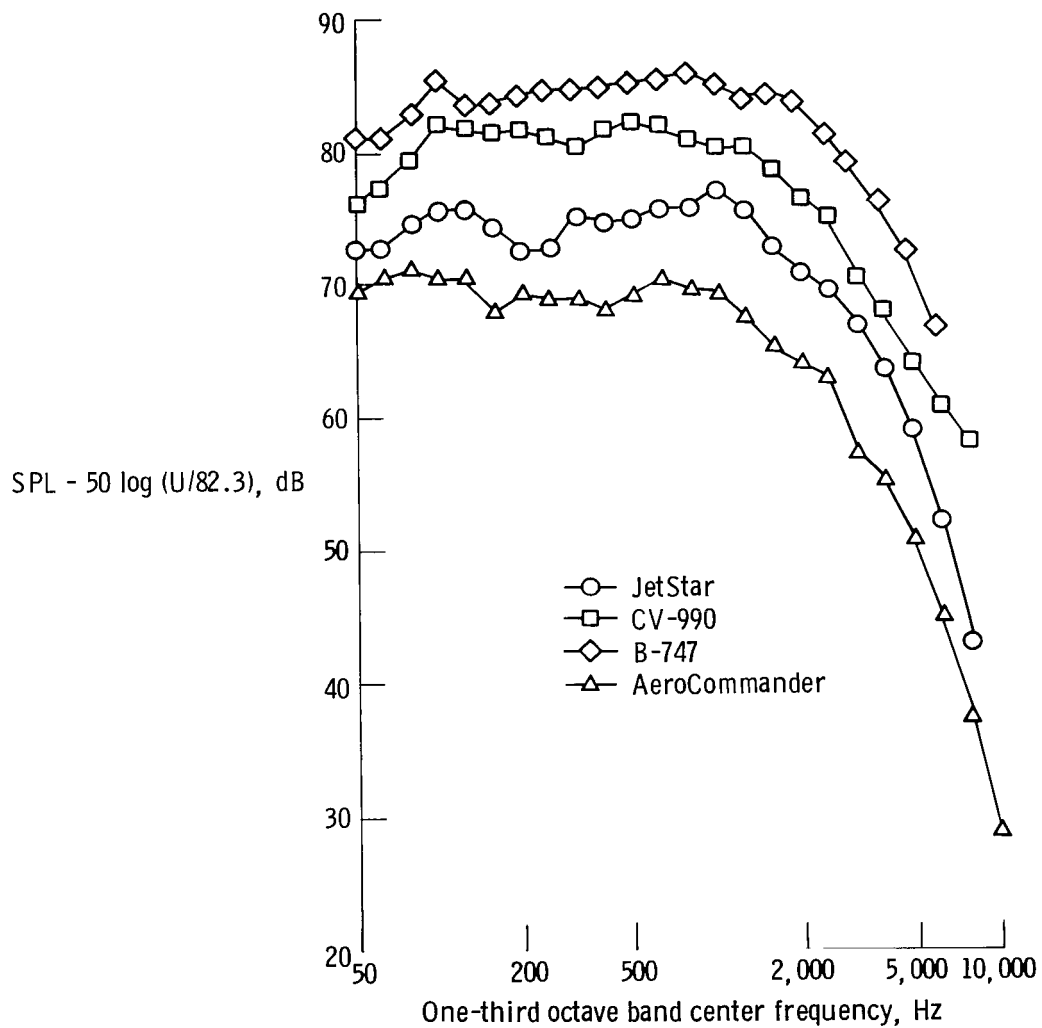

Figure 14. Airframe noise spectra for test aircraft in the landing configuration. Data were normalized to $U = 82.3$ m/sec.

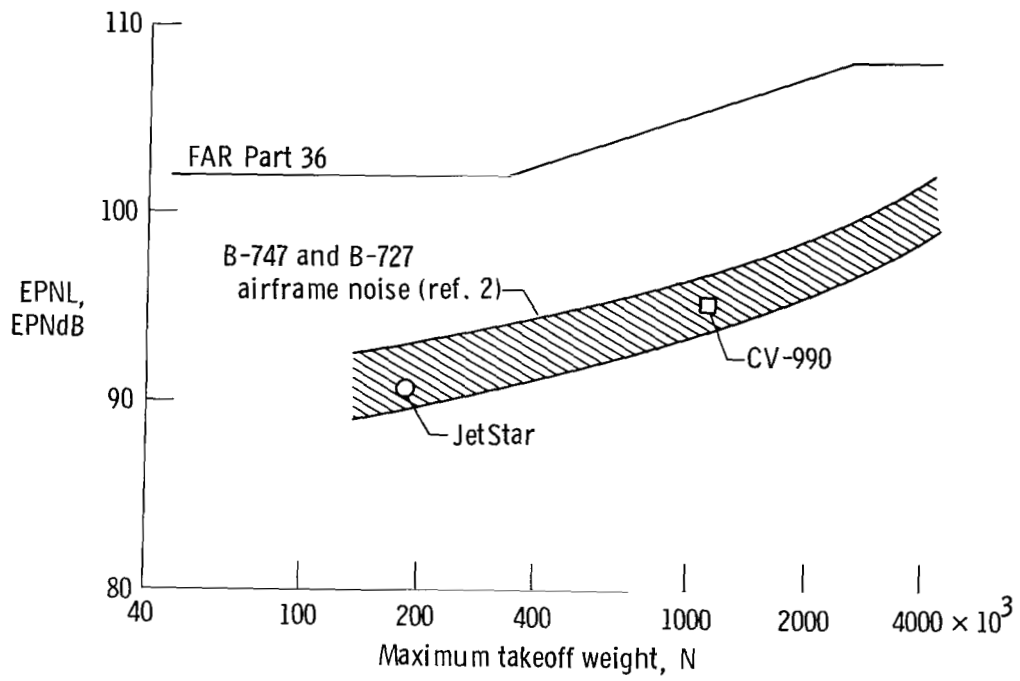

Figure 15. Comparison of JetStar, CV-990, B-747, and B-727 effective perceived noise levels with FAR Part 36 criterion for maximum approach noise.

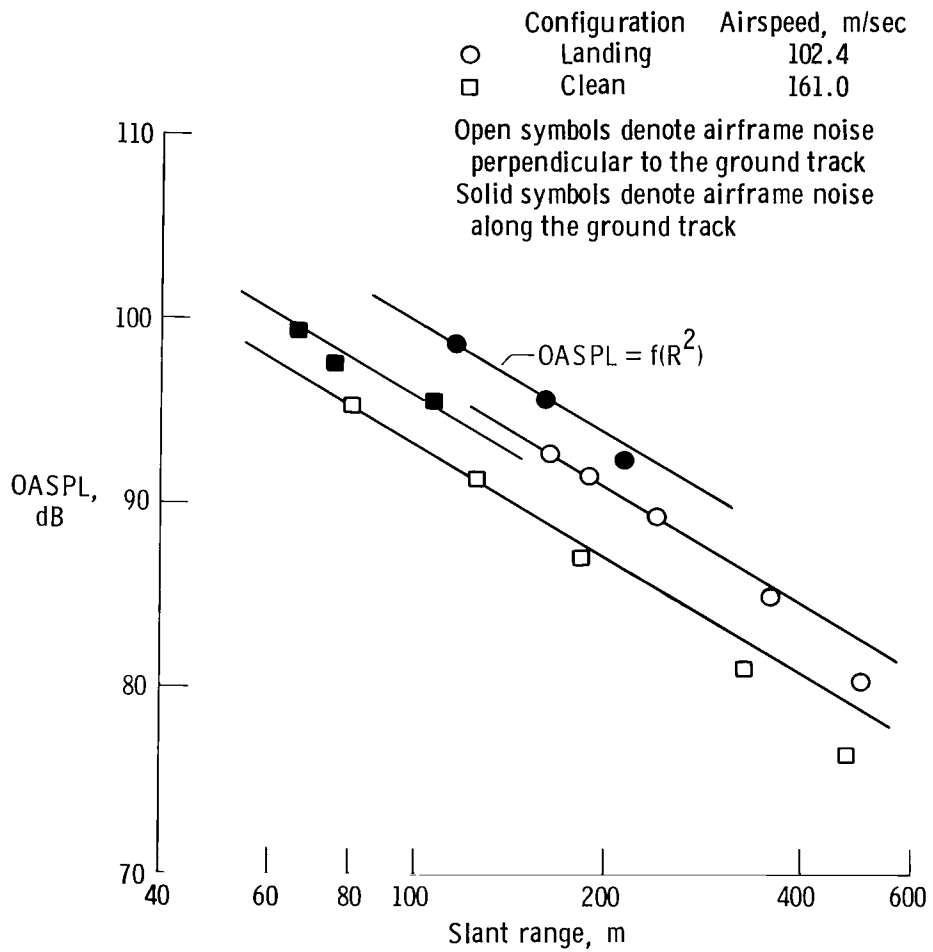

Figure 16. Variation of airframe noise with slant range for CV-990 airplane.

1. Report No. NASA TP-1602	2. Government Accession No.	3. Recipient's Catalog No.
4. Title and Subtitle LANDING APPROACH AIRFRAME NOISE MEASUREMENTS AND ANALYSIS	5. Report Date January 1980	6. Performing Organization Code
7. Author(s) Paul L. Lasagna, Karen G. Mackall, Frank W. Burcham, Jr., and Terrill W. Putnam	8. Performing Organization Report No. H-1075	10. Work Unit No. 535-03-14
9. Performing Organization Name and Address NASA Dryden Flight Research Center P.O. Box 273 Edwards, California 93523	11. Contract or Grant No.	13. Type of Report and Period Covered Technical Paper
12. Sponsoring Agency Name and Address National Aeronautics and Space Administration Washington, D. C. 20546	14. Sponsoring Agency Code	
15. Supplementary Notes		
16. Abstract		
<p>Flyover measurements of the airframe noise produced by the AeroCommander, JetStar, CV-990, and B-747 airplanes are presented for various landing approach configurations. Empirical and semiempirical techniques are presented to correlate the measured airframe noise with airplane design and aerodynamic parameters.</p> <p>Airframe noise for the jet-powered airplanes in the clean configuration (flaps and gear retracted) was adequately represented by a function of airplane weight and the fifth power of airspeed.</p> <p>The airframe noise for all four aircraft in the landing configuration (flaps extended and gear down) varied with the fifth power of airspeed. However, this noise level could not be represented by the addition of a constant to the equation for clean-configuration airframe noise.</p> <p>The airframe noise of the JetStar and CV-990 in the landing configuration was approximately 10 effective perceived noise decibels below the current 1969 FAR Part 36 certification requirements.</p>		
17. Key Words (Suggested by Author(s)) Noise Acoustics Flyover noise Noise prediction	18. Distribution Statement Unclassified-Unlimited	STAR Category: 01
19. Security Classif. (of this report) Unclassified	20. Security Classif. (of this page) Unclassified	21. No. of Pages 37
		22. Price* \$3.75

*For sale by the National Technical Information Service, Springfield, Virginia 22161

National Aeronautics and
Space Administration

Washington, D.C.
20546

Official Business
Penalty for Private Use, \$300

THIRD-CLASS BULK RATE

Postage and Fees Paid
National Aeronautics and
Space Administration
NASA-451



7 1 U, A, 122179 S00903DS
DEPT OF THE AIR FORCE
AF WEAPONS LABORATORY
ATTN: TECHNICAL LIBRARY (SUL)
KIRTLAND AFB NM 87117

NASA

S

POSTMASTER: If Undeliverable (Section 158
Postal Manual) Do Not Return