



3 1176 00154 3959

NASA CR-159,165

# NASA Contractor Report 159165

NASA-CR-159165  
19800008318

ALTITUDE CHARACTERISTICS OF SELECTED AIR  
QUALITY ANALYZERS

J. H. White, R. Strong, and J. B. Tommerdahl

RESEARCH TRIANGLE INSTITUTE  
Research Triangle Park, North Carolina 27709

**LIBRARY COPY**

**JAN 21 1980**

NASA Purchase Order L-96783A  
November 1979

LANGLEY RESEARCH CENTER  
LIBRARY, NASA  
HAMPTON, VIRGINIA

**NASA**

National Aeronautics and  
Space Administration

**Langley Research Center**  
Hampton, Virginia 23665



RTI/1833/00-03F

RTI Project Number 43U-1833

ALTITUDE CHARACTERISTICS OF  
SELECTED AIR QUALITY ANALYZERS

FINAL REPORT

Purchase Order No. L-96783A

Prepared for

National Aeronautics and Space Administration  
Langley Research Center  
Hampton, Virginia 23665

November 1979

N80-16578 #

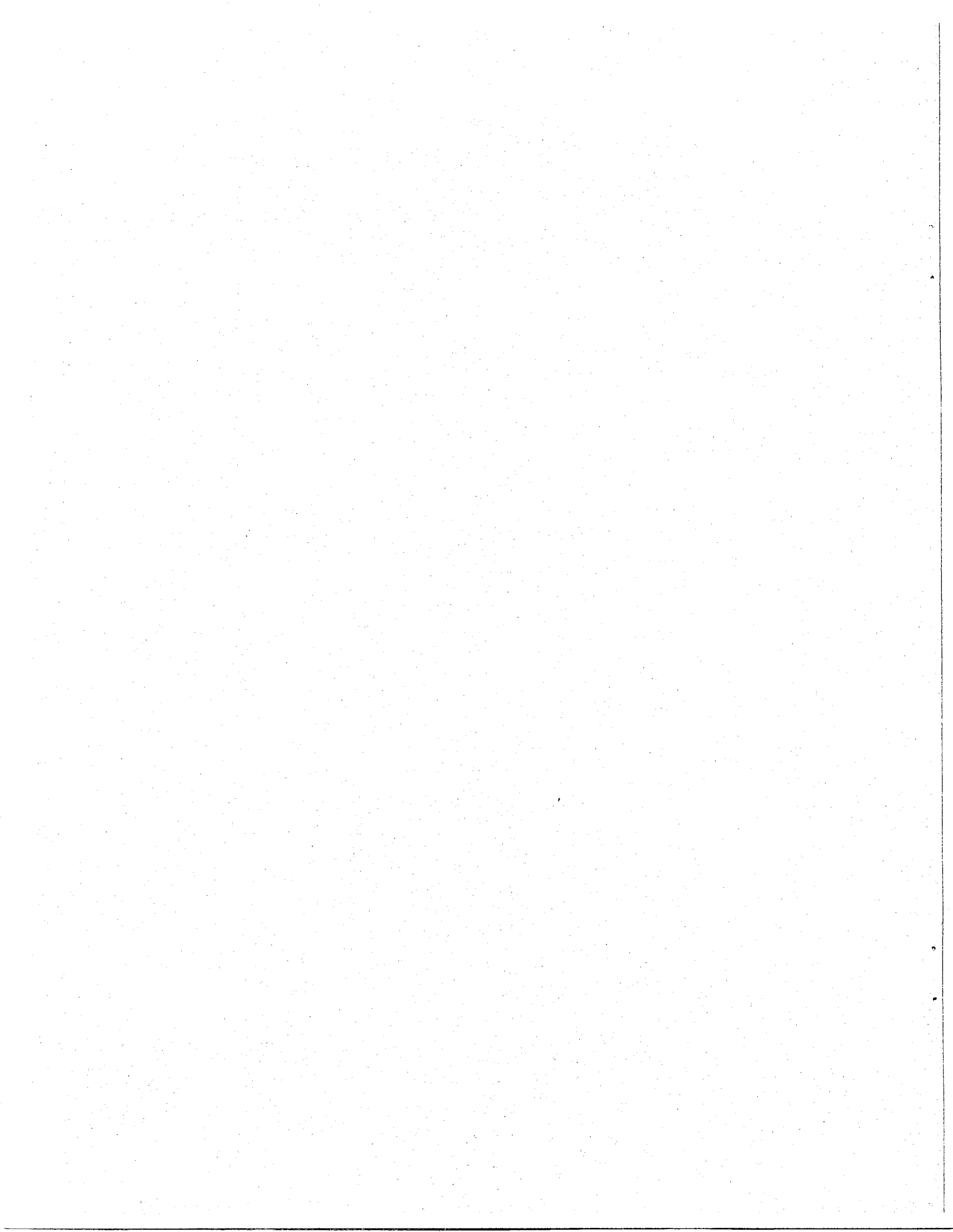

## ABSTRACT

The results of an investigation to measure the effects of altitude (pressure) on the operation and sensitivity of various air quality analyzers are discussed in this report. The selected analyzers are those frequently flown on aircraft for monitoring air quality. The instrumentation selected for study include two ozone analyzers, U.V. absorption and chemiluminescence principle, a nitrogen oxides chemiluminescence detector, and a sulfur dioxide flame photometric detector. The altitude range considered is 600 meters to 3000 meters for the nitrogen oxides and sulfur dioxide instruments and 600 meters to 7500 meters for the ozone instrument. Calibration curves for altitude corrections to the sensitivity of the instruments are presented along with discussion of observed instrument behavior.

The report includes a discussion of the experiment's set-up, test procedures, and data reduction methods used for the above investigation.

## ACKNOWLEDGEMENTS

The experimental testing described in this report was accomplished at the Environmental Protection Agency Altitude Simulation test facility located at the Northrup Environmental Sciences Facility in Las Vegas, Nevada. These tests were made possible by assistance and cooperation received from personnel at both the EPA and Northrup organizations. Specific individuals include Dr. David N. McNelis, Mr. Robert N. Snelling, and Mr. Jeffrey van Ee of EPA, who arranged for the use of the chamber and support apparatus; and Mr. Sydney J. Gordon, Mr. George W. Siple and Mr. Melvin P. Johnson of Northrup, who made their facilities available to RTI for the tests, both during normal working hours and on the weekends.

This effort was conducted under National Aeronautics and Space Administration Purchase Order Number L96783A under the direction of Dr. Gerald L. Gregory. On site direction was provided by Mr. Richard J. Bendura with technical assistance from Mr. Burt R. Emerson, Jr., both from NASA.

## TABLE OF CONTENTS

	<u>Page</u>
1.0 INTRODUCTION . . . . .	1
2.0 TEST DESCRIPTION . . . . .	3
2.1 Test Equipment Configuration. . . . .	3
Chamber Description. . . . .	3
Gas Inlet Configuration. . . . .	4
Calibration System . . . . .	4
2.2 Test Procedure. . . . .	8
3.0 TEST RESULTS . . . . .	9
3.1 Dasibi O <sub>3</sub> Monitor . . . . .	9
3.2 Monitor Labs O <sub>3</sub> Monitor . . . . .	14
3.3 Monitor Labs NO-NO <sub>x</sub> Monitor . . . . .	14
3.4 Meloy SO <sub>2</sub> Analyzer. . . . .	14

## LIST OF FIGURES

<u>FIGURE NO.</u>	<u>PAGE</u>
1 Calibration Gas Feeding System Used to Supply Known Concentrations to Instruments During Altitude Tests	5
2 Calibration System	6
3 Dasibi Ozone Monitor Calibration Curve	11
4 Normalized Altitude Response of Dasibi Ozone Analyzer	12
5 Monitor Labs Ozone Monitor Calibration Curve	17
6 Normalized Altitude Response of Monitor Labs Ozone Analyzer	18
7 Monitor Labs NO-NO <sub>x</sub> Analyzer Calibration Curve	20
8 Normalized Altitude Response of Monitor Labs NO-NO <sub>x</sub> Analyzer	21
9 Calibration Curve of Meloy 185 SO <sub>2</sub> Analyzer	23
10 Altitude Response of Meloy 185 SO <sub>2</sub> Analyzer for First Test	24
11 Altitude Response of Meloy 185 SO <sub>2</sub> Analyzer for Second Test	25

## LIST OF TABLES

<u>TABLE NO.</u>	<u>PAGE</u>
1 DATA FROM ALTITUDE RESPONSE TESTS - DASIBI OZONE MONITOR NASA NO. 180280, INLET CONCENTRATION $\approx$ 174 PPB READOUT TAKEN FROM PANEL DISPLAY	13
2 DATA FROM ALTITUDE RESPONSE TESTS - MONITOR LABS O <sub>3</sub> MONITOR NASA NO. 183369, INLET CONCENTRATION $\approx$ 174 PPB INSTRUMENT ON 0 to .5 PPM RANGE	19
3 DATA FROM ALTITUDE RESPONSE TESTS - MONITOR LABS 8440 NO-NO <sub>x</sub> MONITOR NASA NO. 180895, INLET CONCENTRATION: NO-74 PPB, NO-118 PPB, NO <sub>x</sub> -192PPB	22
4 DATA FROM ALTITUDE RESPONSE TESTS - MELOY 185 SULFUR MONITOR NASA NO. 175958	26



## 1.0 INTRODUCTION

Continuous type air monitoring analyzers generally rely on a chemical reaction of known gases with gases of unknown concentration for the detection and measurement of the unknown gas concentrations. These reactions, through either combustion or chemiluminescent mechanisms, produce light which is measured usually with a photomultiplier system. Since the measured quantity of light is proportional to the concentration of a particular gas at the inlet, the concentration may be determined by measuring and recording the amount of light produced by the reaction.

The ambient pressure onboard typical airborne air sampling platforms is not constant, but rather changes significantly with altitude of the aircraft. (There is a 30% decrease in pressure at altitude of 3060 meters or 10,000 feet from sea level.) This change in ambient pressure causes changes in instrumentation response due to: (1) changes in pressures internal to the instrument where gas reactions are taking place, and (2) changes in flow rates due to changes in reference pressures for flow regulators, or changes due to changes in air density. These changes usually affect the instrument sensitivity and in some cases affect the background level or "instrument zero response".

The Research Triangle Institute conducted tests for altitude characterization of two  $O_3$ , one  $NO-NO_x$ , and one  $SO_2$  analyzers for the National Aeronautics and Space Administration. The objective of these tests was to quantify the effects of changes in instrument response with changing ambient pressure (simulated altitude). The tests were conducted in a test chamber located at the Environmental Protection Agency in Las Vegas, Nevada. Each analyzer was placed in the chamber and exposed to known concentrations of the gas generated externally by a conventional calibration system. The instrument response was measured and recorded by a digital voltmeter and strip chart recorder for later analysis. Each analyzer was subjected to at least two altitude tests sequences, usually on two sequential days, to verify repeatability of the test results.

This report contains a description of the apparatus and procedures utilized during these tests (Section 2.0). In Section 3.0 graphs describing instrument performance are included for the instruments which were run, specifically:

Dasibi 1003-AAS Ozone Monitor,  
Monitor Labs 8410 A Ozone Monitor,  
Monitor Labs 8440 NO-NO<sub>x</sub> Monitor, and  
Meloy 185-2 SO<sub>2</sub> Monitor.

Two duplicate test runs were usually conducted to demonstrate repeatability and verify the correct operation of each instrument during the altitude tests. Due to insufficient time, no parameter variation studies were conducted where set operational parameters (e.g., support gas or sample flow, supply pressures, etc.) were varied to determine their effect on the altitude characteristics. Some of these parameters might be quite critical in determining the altitude response (e.g., the H<sub>2</sub> flow in a SO<sub>2</sub> analyzer is known to be quite critical in determining the baseline pressure dependence of the Meloy SO<sub>2</sub> instrument). During normal operation of the analyzer these parameters might be set to slightly different values than those used during the tests, possibly resulting in altitude effects differing from those obtained here. Also, normal aging effects might affect the altitude characteristics. In order to determine the magnitude of errors associated with these phenomena, many tests would be necessary over a long period, an effort significantly above the effort outlined for this task. Therefore, the test results given in this report should only be used for raw data for compensation in the absence of more current information. The results illustrated here might better be used as example profiles whose exact magnitudes would be verified with inflight tests conducted during the air sampling program.

Use of commercial products or names of manufacturers in this report does not constitute official endorsement of such products or manufacturers, either expressed or implied, by the National Aeronautics and Space Administration.

## 2.0 TEST DESCRIPTION

### 2.1 Test Configuration

Tests were conducted in a WEBBER<sup>1</sup> (Model WF-27-40+200 HV) chamber capable of providing a test environment with controlled pressure, temperature, and dew point. Controlled environment ranges are:

Temperature	-40 to 90°C
Humidity	2 to 98%
Pressure	equivalent of sea level to 30 kilometers

For these tests only the pressure (simulated altitude) was varied. The temperature was maintained at constant level over the duration of the tests<sup>2</sup>. The test chamber itself consisted of a rectangular cell of roughly 60 cm W x 90 cm D x 150 cm H with two adjustable shelves. This area was large enough to accommodate two instruments with space remaining for additional support equipment in the bottom of the chamber. Three ports were available on the side for feedthrough of test and support gases. Each feedthrough consisted of a length of 0.6 cm OD stainless steel tubing with stainless steel Swagelok<sup>®</sup> connectors on each end. Electrical feedthroughs were provided for signal wires (24 individual leads) and 110 VAC power (2 wire plus ground).

---

<sup>1</sup> WEBBER MANUFACTURING COMPANY, P.O. Box 217, Indianapolis, Indiana 46206.

<sup>2</sup> Although it would be desirable to have also determined temperature characteristics while at the chamber site, such tests were not performed because, in the opinion of the author, such tests, if performed at all, must be carefully performed in order that misleading results not be obtained. Consideration must be given to ventilation around the instrument and internal temperatures at critical points, as well as ambient temperature, before general statements may be made about temperature performance. A study which is sufficiently comprehensive to include these considerations is well above the funded level of effort being described here.

Figure 1 illustrates the system used to supply known concentrations (mixing ratios) of gases to the analyzers under test in the chamber. The sample inlet system was designed to allow the calibration system to operate always at ambient pressure where its performance characteristics are well known. The negative pressure of the chamber, while simulating higher elevation, is used to pull the calibration gas into the chamber. The instrument(s) were connected to a small manifold inside the chamber. This manifold was used to insure that the instrument inlet was maintained at the same pressure as the test chamber, so possibly misleading effects of pressurization of inlets would not be induced. In order that pressurization or depressurization of the calibration system not be induced, a vent was provided on the outlet of the calibration system for bleeding of excess amounts of the test gas not pulled into the chamber. A mass flow meter was used to monitor the amount bled off to insure that: (1) more air was not pulled into the chamber than the calibration system was supplying (causing contamination of sample gas with room air), or (2) sufficient sample air was pulled through the chamber to keep the manifold inside the chamber flushed with test gas. The amount of gas going into the chamber is regulated by a restriction consisting of clean 0.15 cm I.D. Teflon<sup>®</sup> tubing. Several pieces of different lengths were used during the test to maintain a vent flow as measured on the Hastings flowmeter of between 0.2 and 1 L/min. yielding approximately 4 1/2 to 5 1/2 liters of sample going into the chamber (before expansion to the lower pressure).

The calibration system used to furnish the test gas to analyzers is shown schematically in Figure 2. It consisted of two independent systems housed in portable enclosures. Sulfur dioxide bearing test atmospheres was generated by dilution of 23 ppm SO<sub>2</sub> in nitrogen with ambient air scrubbed to remove SO<sub>2</sub>. Preconditioned activated charcoal was used as the scrubbing agent in order that the levels CO<sub>2</sub> in the dilution air was unchanged.

For NO<sub>x</sub> and ozone calibrations a gas phase titration system was used. Fifty parts of NO in nitrogen was diluted with air for NO and NO<sub>x</sub> channel calibrations. NO<sub>2</sub> test mixtures were generated by reaction of the diluted NO mixture with ozone generated by an ultraviolet O<sub>3</sub> generator.

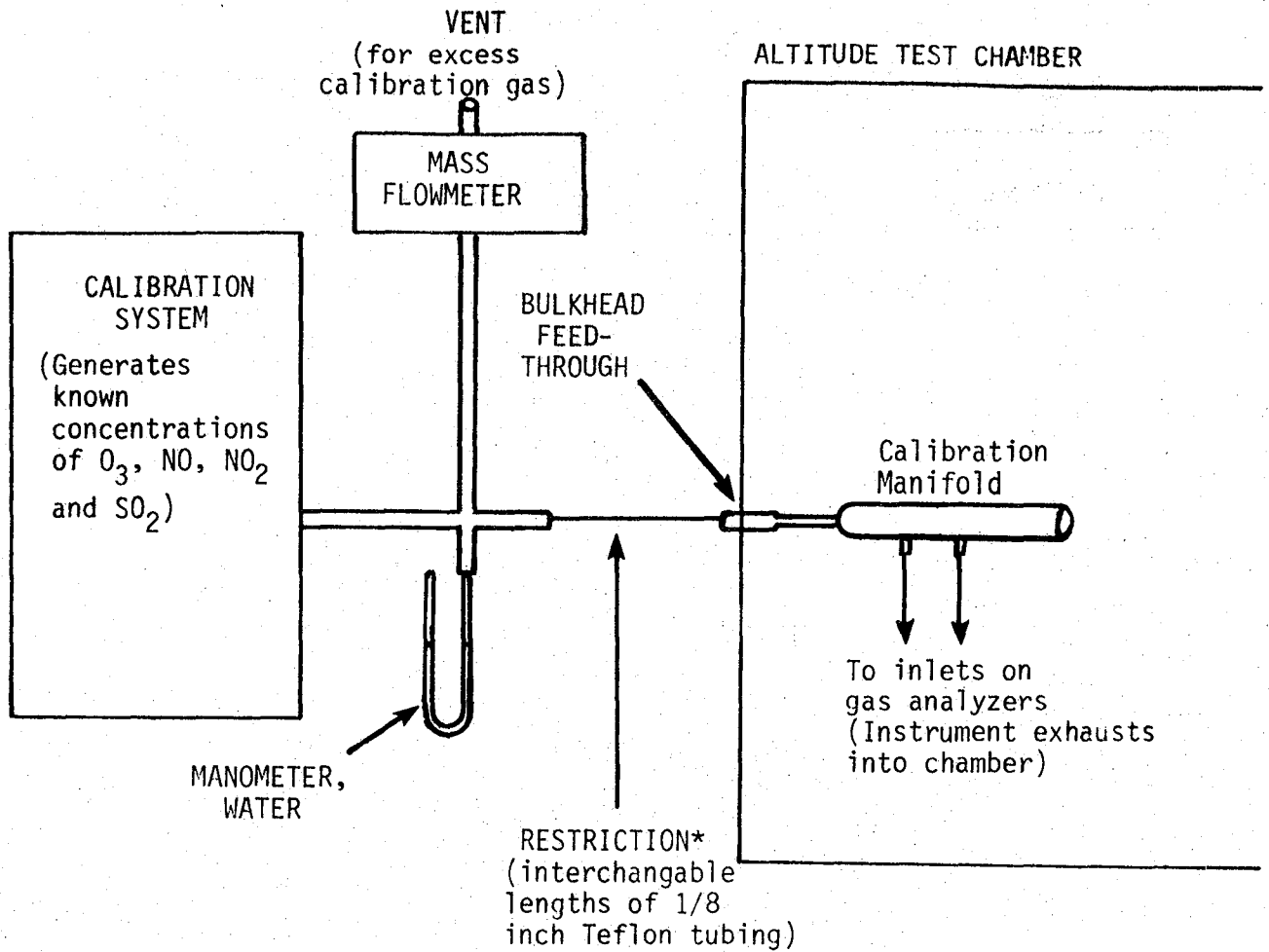

\*The length of the restriction line required changes with pressure within the chamber. The length was selected to allow a sufficient flow of test gas into the chamber while drawing no more gas than produced by the calibration system. Several pieces of different lengths were used and changed as required during the test.

Figure 1. Calibration Gas Feeding System Used to Supply Known Concentrations to Instruments During Altitude Tests.

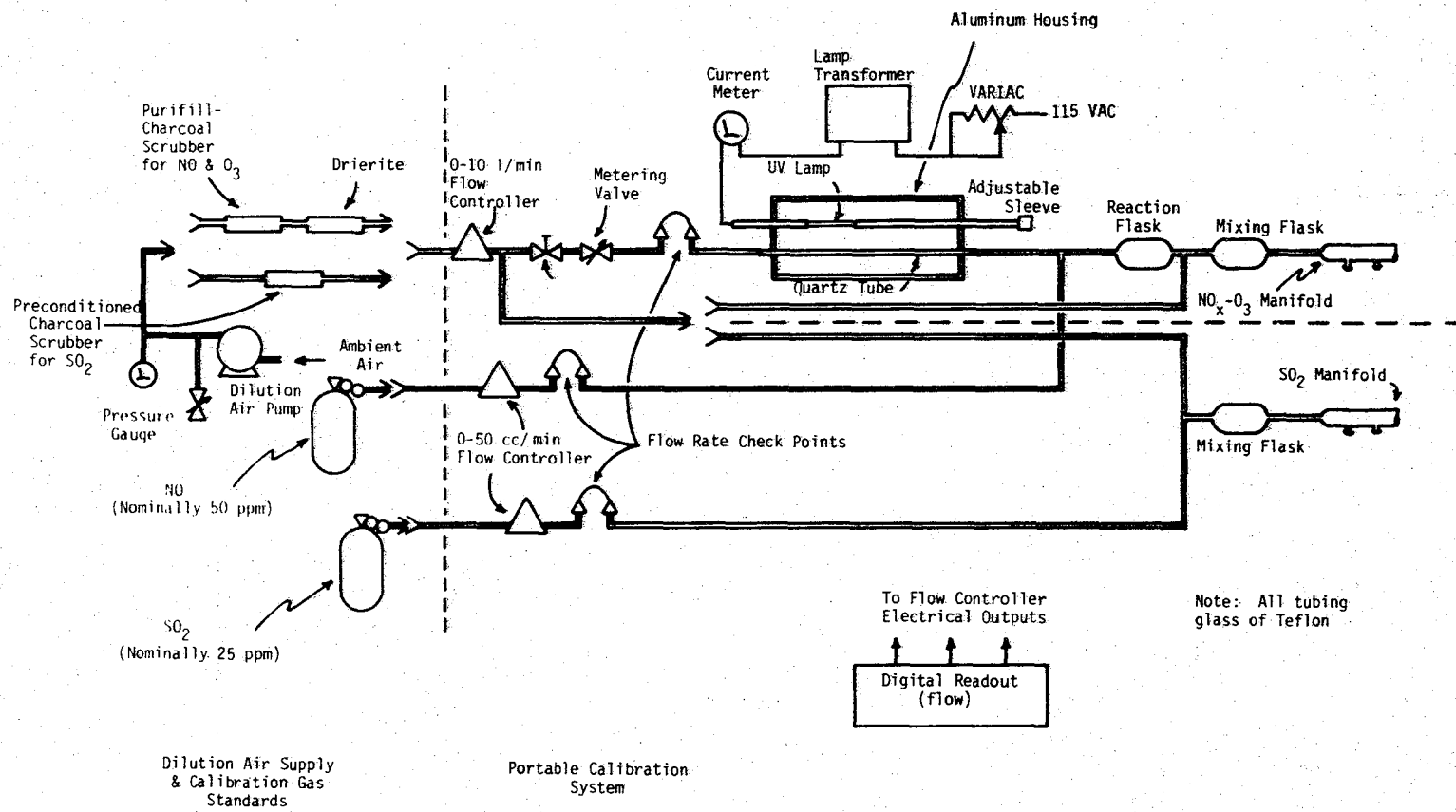

Figure 2 Calibration System

The  $\text{NO}_2$  concentration was determined by noting the depression in NO values produced by the introduction of ozone. Since the  $\text{NO}_2$  concentration in ppm is equal to the ozone generator output in ppm, this procedure referenced the output of the ozone generator using the NO cylinder gas as a secondary standard.

During these tests the calibration system was used in the normal manner to perform a multipoint calibration of each analyzer prior to altitude runs. This procedure verified proper instrument linearity (or expected non-linearity in the case of the  $\text{SO}_2$  analyzer) and when the calibration coefficients were close to the expected values, gave confidence the analyzer was operating normally. During the altitude tests the multipoint capability of the calibration system was not used, but the system was used merely to generate constant concentrations for the purpose of evaluating variations in instrument response with changing environment pressure.

## 2.2 Test Procedure

The testing of all analyzers was done by similar procedures. This procedure consisted of the following sequence of events, modified only when necessary to allow additional time for equilibration or retesting for verification of suspect data. The procedure was as follows:

1. Connect instruments to be tested to power and support gases and operate at ambient pressure for at least four hours and overnight if possible. (Generally instruments were tested individually; however, because of the relatively small size of the ozone instruments both units tested could be placed in the chamber and tested simultaneously.)
2. Perform multipoint calibration of analyzer at points covering range anticipated in normal ambient monitoring.
3. Perform test of analyzer response to constant concentrations of test gas with varying pressure. Data was acquired usually at 600 m increments over a range from 600 m (elevation of test site) to 3 km for all instruments except ozone (to 7500 m for ozone). Instrument response was monitored on a strip chart recorder and digital voltmeter. Recorded values in this report were derived from the voltmeter with the recorder providing an indication when the values had stabilized.
4. Leave analyzer operating in chamber overnight at ambient conditions. Plot and examine data for suspect points. Determine test conditions for verification run for following day.
5. Perform repeat test of conditions where suspicious points were noted. Verify repeatability of points noted the previous day. If differences between runs are noted, rerun entire test.
6. Remove analyzer from chamber and install next analyzer to be tested.



### 3.0 TEST RESULTS

#### 3.1 Dasibi Ozone Monitor

The calibration plot of the Dasibi analyzer is plotted in Figure 3 and the normalized altitude response for 600 to 7500 m is shown in Figure 4. The data plotted in Figure 4 are tabulated in Table 1. The latter figure illustrates the linear dependence of the analyzer response on environmental pressure. This linear dependence results from the decrease in air density in the optical cell with decreasing pressure. This phenomena has been noted in earlier tests performed by RTI on another Dasibi instrument. The repetition of these results served as an indication that the test configuration was functioning as intended.

The only problem encountered with this instrument occurred at pressures near ambient pressure (between 600 and 1200 meters effective altitude). When the analyzer was noted in the instrument zero (with corresponding shift produced in the up-scale readings as well). The analyzer was operated with the 50 ppb offset activated in order that the negative excursions of the response could be observed. Efforts at determining the cause of the transient were unsuccessful due to insufficient time. The effect of this problem is somewhat high scatter in the ambient point on the Normalized Altitude Response Plot. The problem occurred only in the Dasibi instrument. It was not evident in the other  $O_3$  analyzer being tested simultaneously.

Note that the ambient calibration of this analyzer was done at 663 m. In order to determine instrument response at other altitudes than the one at which the calibration was performed, a numerical adjustment is necessary. For the Dasibi instrument with its linear ambient pressure-sensitivity relationship, a simple mathematic expression may be written for computation of instrument sensitivity at pressures other than the ambient pressure at which it was calibrated. This expression is:

$$\frac{R_{alt}}{R_{cal alt}} = \frac{P_{o alt}}{P_{o cal}} \quad (\text{for Dasibi instrument only})$$

where:

- $P_{o cal}$  - ambient pressure at which instrument was calibrated
- $P_{o alt}$  - ambient pressure where readings were taken
- $R_{alt}$  - instrument response to ozone at ambient pressure  $P_{o alt}$
- $R_{cal alt}$  - instrument response at ambient pressure where calibration was performed

This relationship expresses the linear dependence between the instrument response and pressure verified during these tests. This expression yields the following for the response of this analyzer at sea level using the calibration performed at the 663 m altitude:

$$\frac{R_{alt}}{R_{cal alt}} = \frac{P_{o alt}}{P_{o cal}} \left( \frac{760 \text{ mmHg}}{760 \text{ mmHg}} \right) = 1.065$$

This indicates the instrument to exhibit a 7.65% increase in sensitivity at sea level over the 663 m altitude. Therefore, the measured calibration slope of 0.84 obtained at 663 m for this instrument would become 0.90 at sea level.

Note that although the actual testing of this instrument was carried out only over the range 663 to 7500 m, the results of the tests verify a predictable relationship (linear dependence on pressure) which is probably true outside the range of the tests. Therefore instrument response at sea level pressure may be computed with some degree of confidence. The other instruments tested did not exhibit the same predictable altitude response characteristic and therefore extrapolating the conclusions outside the test range is somewhat risky.

DASIBI MODEL 1003 - AAS  
NASA NO. 180280  
Calibration Curve

---

50ppb Offset Switch-On  
Calibration Altitude 663 meters  
Date of Test - June 19, 1979  
Concentration(ppb) = 0.84x(reading) - 52

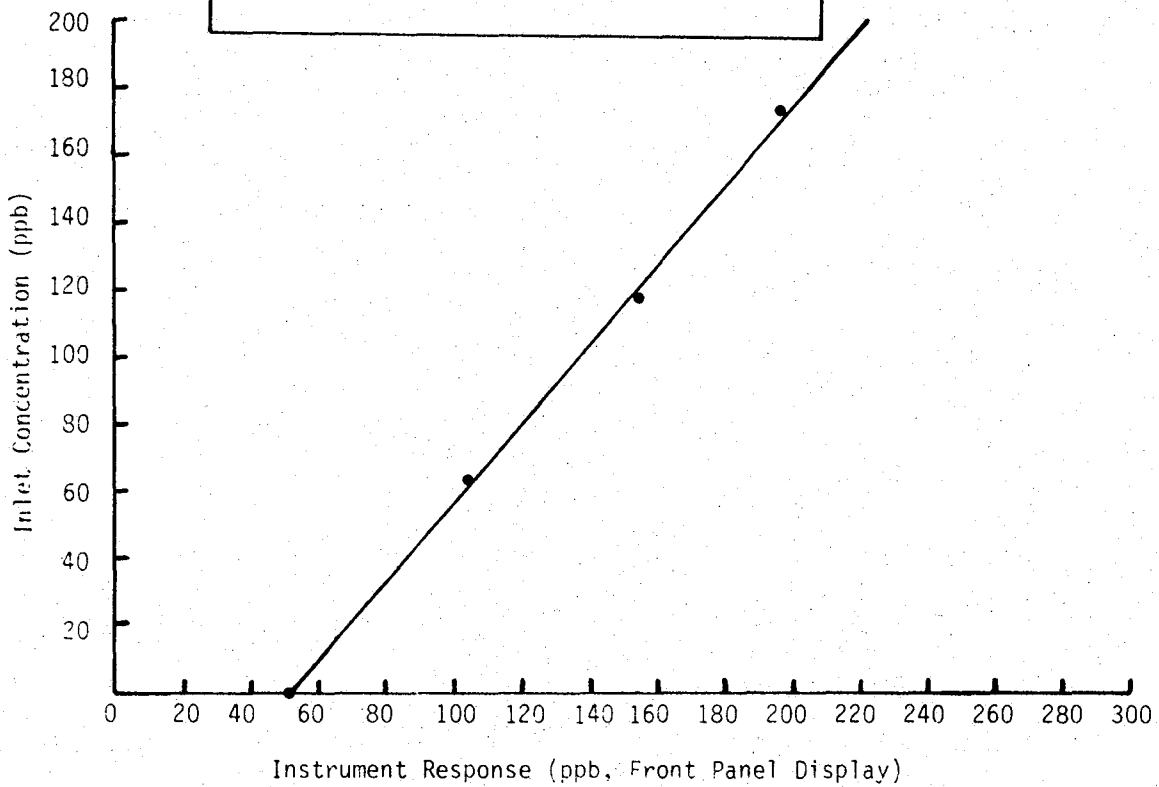

Figure 3 Dasibi Ozone Monitor Calibration Curve

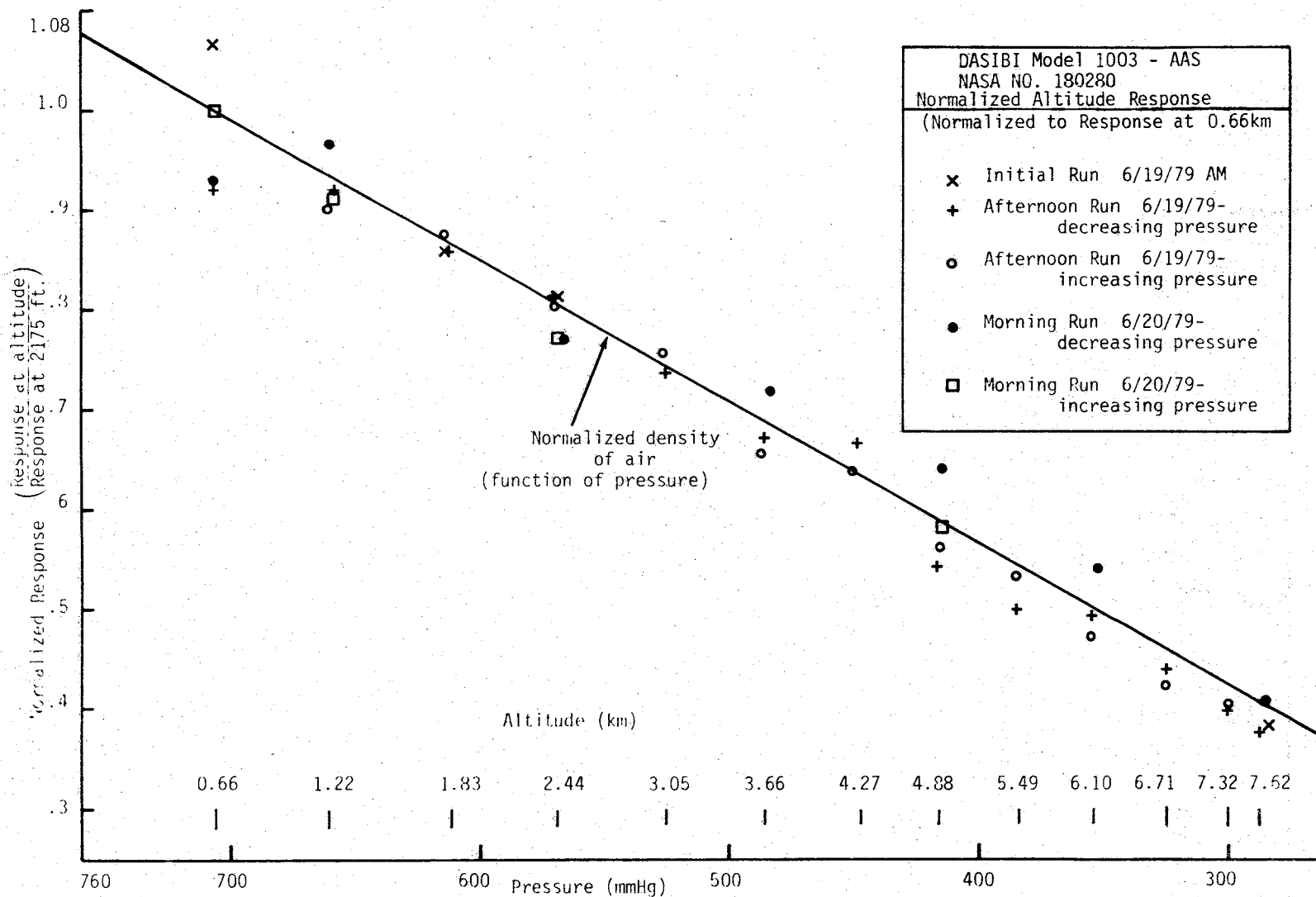

Figure 4. Normalized Altitude Response of Dasibi Ozone Analyzer

Table 1 DATA FROM ALTITUDE RESPONSE TESTS - DASIBI OZONE MONITOR  
 NASA NO. 180280  
 INLET CONCENTRATION  $\approx$  174 PPB-READOUT TAKEN FROM PANEL DISPLAY

(Values in parenthesis are response to ozone free air)

Simulated Altitude (km)	Pressure (mmHg)	Instrument Display - (ppb)				
		Run #1 6/19 am	Run #2 6/19 pm decreasing pressure	Run #3 6/19 am increasing pressure	Run #4 6/20 decreasing pressure	Run #5 6/20 increasing pressure
ambient .66	706	196 (53)	172 (36)	----	196 (57)	198 (49)
1.22	659	179 (40)	172 (43)	172	184 (40)	177 (41)
1.83	614	166 (45)	166	168	----	----
2.44	569	159 (44)	152	158	155 (40)	158
3.05	525	151 (46)	148	151	----	----
3.66	486	----	139	137	147	----
4.27	448	----	138	134	----	----
4.88	416	----	120	123	132	130 (43)
5.49	384	----	114	119	----	----
6.10	354	----	113	110	117	----
6.71	325	107 (43)	105	103	----	----
7.32	300	----	99	100	----	----
7.62	288	97 (43)	96	96	100 (38)	100 (38)

### 3.2 Monitor Labs O<sub>3</sub> Monitor

The Monitor Labs O<sub>3</sub> monitor was tested over the same altitude range as the Dasibi, 600 to 7500 m. The results of these tests indicate a definite, repeatable dependence of the analyzer response on environmental pressure (or altitude). This analyzer was not expected to obey any linear relationship with pressure as the Dasibi instrument did. However, the results showed the instrument response to be surprisingly close to the linear density response noted for the Dasibi, with only a slight curve near ground level (pressure = 706 mmHg). The calibration curve of this analyzer is shown in Figure 5, while Normalized Altitude Response is shown in Figure 6.

### 3.3 Monitor Labs NO-NO<sub>x</sub> Analyzer

The NO-NO<sub>x</sub> analyzer was calibrated by the gas-phase titration procedure (which was also used to determine the ozone levels generated by the UV ozone generator). The results of this calibration (shown in Figure 7) were in close agreement with the last calibration of this instrument performed at Langley Research Center.

The altitude test run on this instrument showed surprisingly little variation in instrument variability with pressure down to levels equivalent to that occurring at 3 km (see Figure 8). The instrument was not tested at higher altitudes due to high voltage unit breakdown failures in similar instruments, which are known to occur at altitudes above 3 km and are caused by ionization of air at lower pressures.

### 3.4 Meloy 185 SO<sub>2</sub> Analyzer

The Meloy 185 SO<sub>2</sub> analyzer is a flame photometric analyzer for the detection of sulfur compounds. The variations in flame characteristics brought about by pressure changes (and resulting flow changes) cause this instrument to be one of the hardest to characterize completely. For example, this instrument, and other models of the same instrument are susceptible not only to span shifts

with changing pressure, but baseline or zero shifts as well. The situation is further compounded by the fact that parameter changes, such as hydrogen or sample air flow, will further change these pressure characteristics. Add to all of this the fact that the instrument is a non-linear instrument with a response shape which also varies with altitude. It would be an impossible task to characterize completely the instrument for the effects of changes in all of these parameters as they all affect the altitude characteristics. Therefore, the approach taken was to set the analyzer up with a normal set of conditions (e.g.,  $H_2$  and sample air flows set to values indicated by manufacturer, temperature to  $22^{\circ}C$  and monitor output on non-linearized output) and then to make two altitude runs with at least three different gas concentrations. Data from the second run should provide some indication of the repeatability of measured altitude characteristics.

Figure 9 illustrates the non-linear calibration curve obtained for the Meloy 185 at ground level. This curve basically represents the amplified PM tube current resulting from the hydrogen flame light output with fixed voltage subtracted such that zero concentration results in zero output. A linearized output was available on the analyzer being tested. However, the proper operation of a linearizer requires the analyzer to be properly zeroed. Since the analyzer zero level changes with altitude, the zero setting would have to be readjusted at each pressure to maintain a zero offset voltage. Yet this is impossible during the test since the analyzer is sealed in the chamber. Another reason for not using the linearizer is that the shape of the response curve changes somewhat with altitude. Since the linearizer is set up to compensate for a given non-linear curve, changes in this actual curve would cause the linearizer to no longer correctly compensate for the non-linearities.

The response curves for the analyzer for different concentrations of  $SO_2$  over varying altitudes is shown in Figure 10 and 11. These curves were not normalized as previous examples were because the behavior of the instrument with altitude varies somewhat with concentration. For example, a more drastic change is noted in instrument response at lower concentrations than at higher concentrations.

One somewhat disturbing effect noted on this analyzer, that was also observed on other SO<sub>2</sub> analyzers, concerns the behavior of the instrument zero response. As is shown in Figure 10 and 11 the voltage out of the analyzer dropped very rapidly to approximately -60 mV at altitudes of 1500-1800 m and remained at that level for higher altitudes. Stable, accurate readings were not possible in the 0 to 5 ppb region for altitudes above 1500 m, although performance outside of this area equalled that of other analyzers tested.



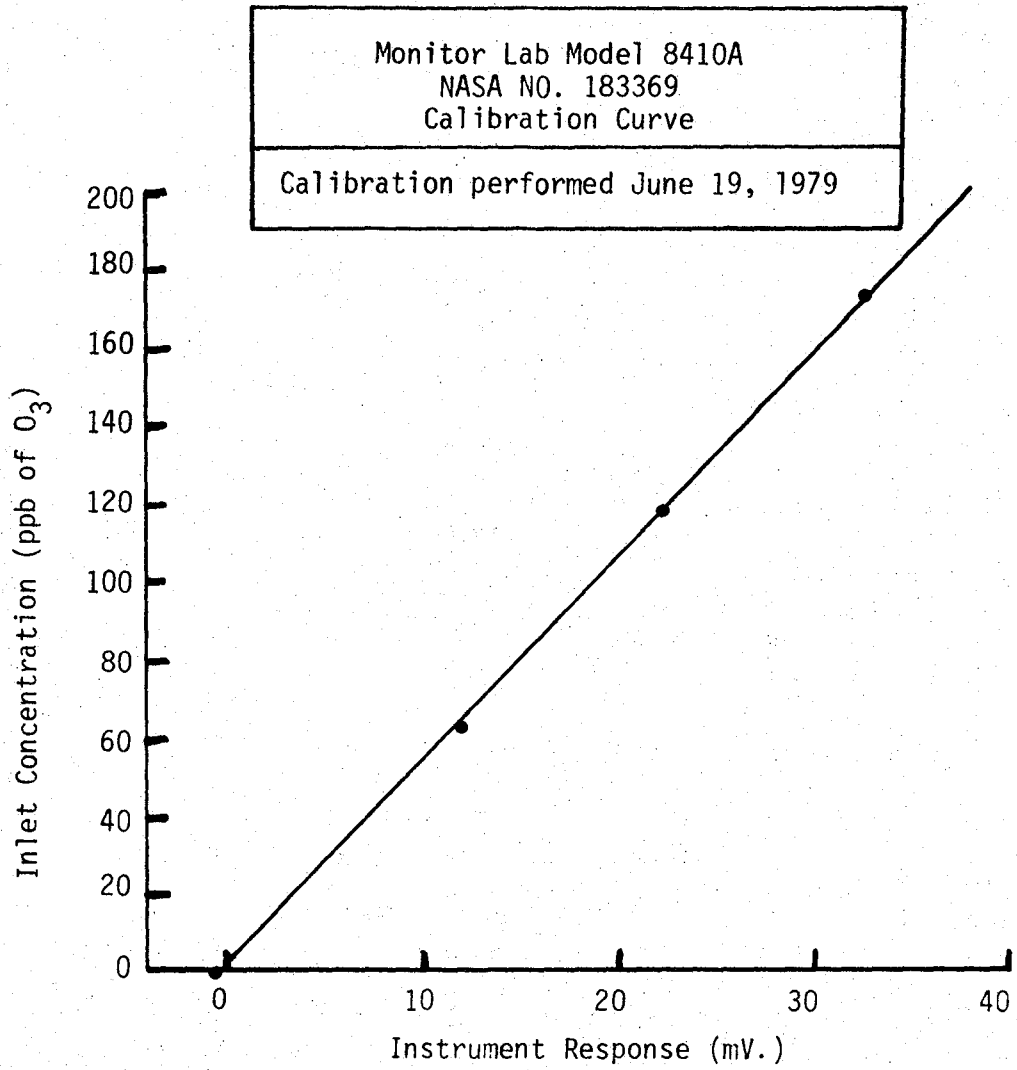

Figure 5. Monitor Labs Ozone Monitor Calibration Curve

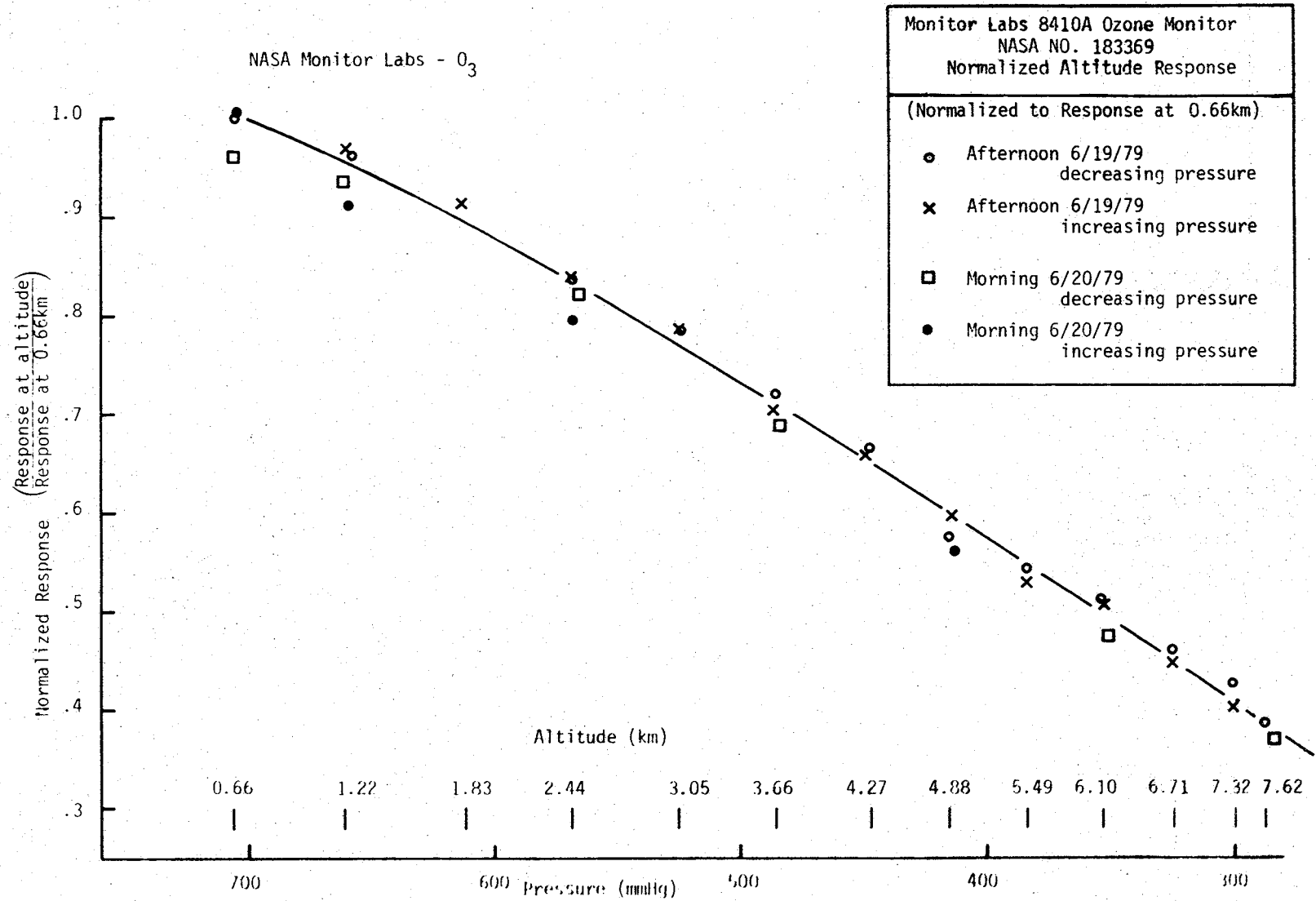

Figure 6. Normalized Altitude Response of Monitor Labs Ozone Analyzer

Table 2 DATA FROM ALTITUDE RESPONSE TESTS - MONITOR LABS O<sub>3</sub> MONITOR  
 INLET CONCENTRATION 174 PPB - INSTRUMENT ON 0 to .5 PPM RANGE  
 (Values in parenthesis are response to ozone free air)

Simulated Altitude (km)	Pressure (mmHg)	Instrument Response - millivolts				
		Run #1 6/19	Run #2 6/20 am decreasing pressure	Run #3 6/20 pm increasing pressure	Run #4	Run #5
Ambient .66	706	32.7 (0.5)	30.9 (0.1)		31.6 (0.4)	33.0 (0.2)
1.22	659	30.6 (0.2)	29.8 (0.2)	30.0	30.8 (0.1)	30.0 (0.3)
1.83	614	28.6 (0.4)	28.7	28.3	----	----
2.44	569	26.8 (0.0)	25.9	26.0	27.0	26.2
3.05	525	24.7 (0.3)	24.4	24.3	----	----
3.66	486	----	22.3	21.8	22.7	----
4.27	448	----	20.6	20.4	----	----
4.88	416	----	17.8	18.2	18.9	18.6 (0.1)
5.49	384	----	16.9	16.4	----	----
6.10	354	13.9 (0.4)	15.9	15.8	15.8	----
6.71	325	----	14.3	13.9	----	----
7.32	300	----	13.3	12.5	----	----
7.62	288	11.5 (0.3)	12.0	12.0	12.4 (.4)	----

Monitor Lab Model No. 8440  
 NASA No. 180895  
 Calibration Curve

Concentration of NO-NO<sub>2</sub>-NO<sub>x</sub>  
 Analyzer by Gas Titration  
 Date Performed 6/20/79  
 Concentration-192ppb of NO

- NO response
- NO<sub>2</sub> response
- × NO<sub>x</sub> response

Results

NO  
 Conc(ppb) = 2.24 x response(mv) - .2

NO<sub>2</sub>  
 Conc(ppb) = 2.23 x response(mv) + .4

NO<sub>x</sub>  
 Conc(ppb) = 2.23 x response(mv) - 3.3

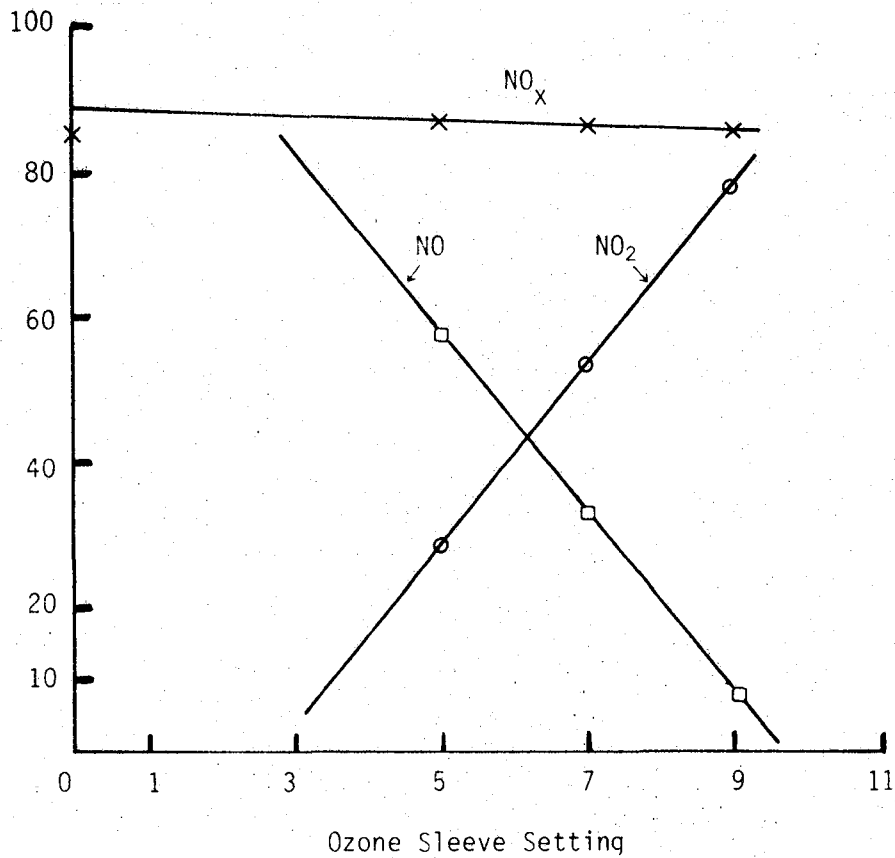

Figure 7 Monitor Labs NO-NO<sub>x</sub> Analyzer Calibration Curve

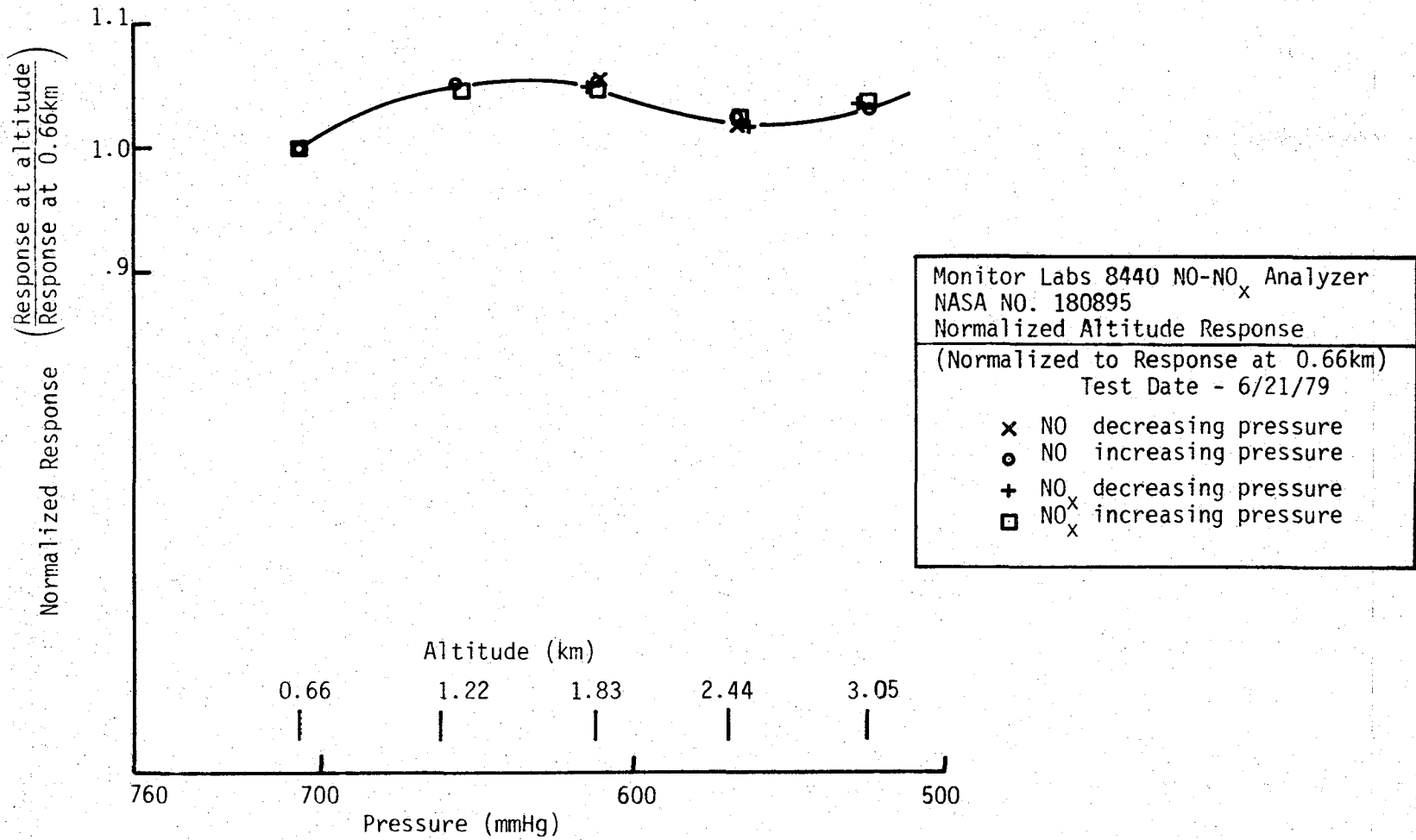

Figure 8. Normalized Altitude Response of Monitor Labs NO-NO<sub>x</sub> Analyzer

Table 3 DATA FROM RESPONSE TESTS - MONITOR LABS 8440 NO-NO<sub>x</sub> MONITOR

NASA NO. 180895

INLET CONCENTRATIONS: NO- 74 PPB NO<sub>2</sub> - 118 PPB NO<sub>x</sub> - 192 PPB

Data Performed 6/21/79

Simulated Altitude (km)	Pressure (mmHg)	NO response (mV)			NO <sub>2</sub> response (mV.)			NO <sub>x</sub> response (mV.)		
		Run #1 Increasing Pressure	Run #2 6/21 Decreasing Pressure	Run #3 6/21 Increasing Pressure	Run #1	Run #2	Run #3	Run #1	Run #2	Run #3
Ambient (0.66)	706	33.0	33.8	36.2	53.0	55.4	54.0	90.9	89.0	90.1
1.22	659	36.6	35.8	38.0	55.6	58.3	57.0	91.2	93.6	94.6
1.83	612	37.8	38.2	38.2	55.5	57.0	57.5	92.8	94.8	94.5
2.44	567	36.4	36.8	37.2	54.2	55.4	54.9	90.1	91.7	92.4
3.05	525	36.1	37.4	37.4	55.7	56.0	56.0	91.6	93.1	93.1

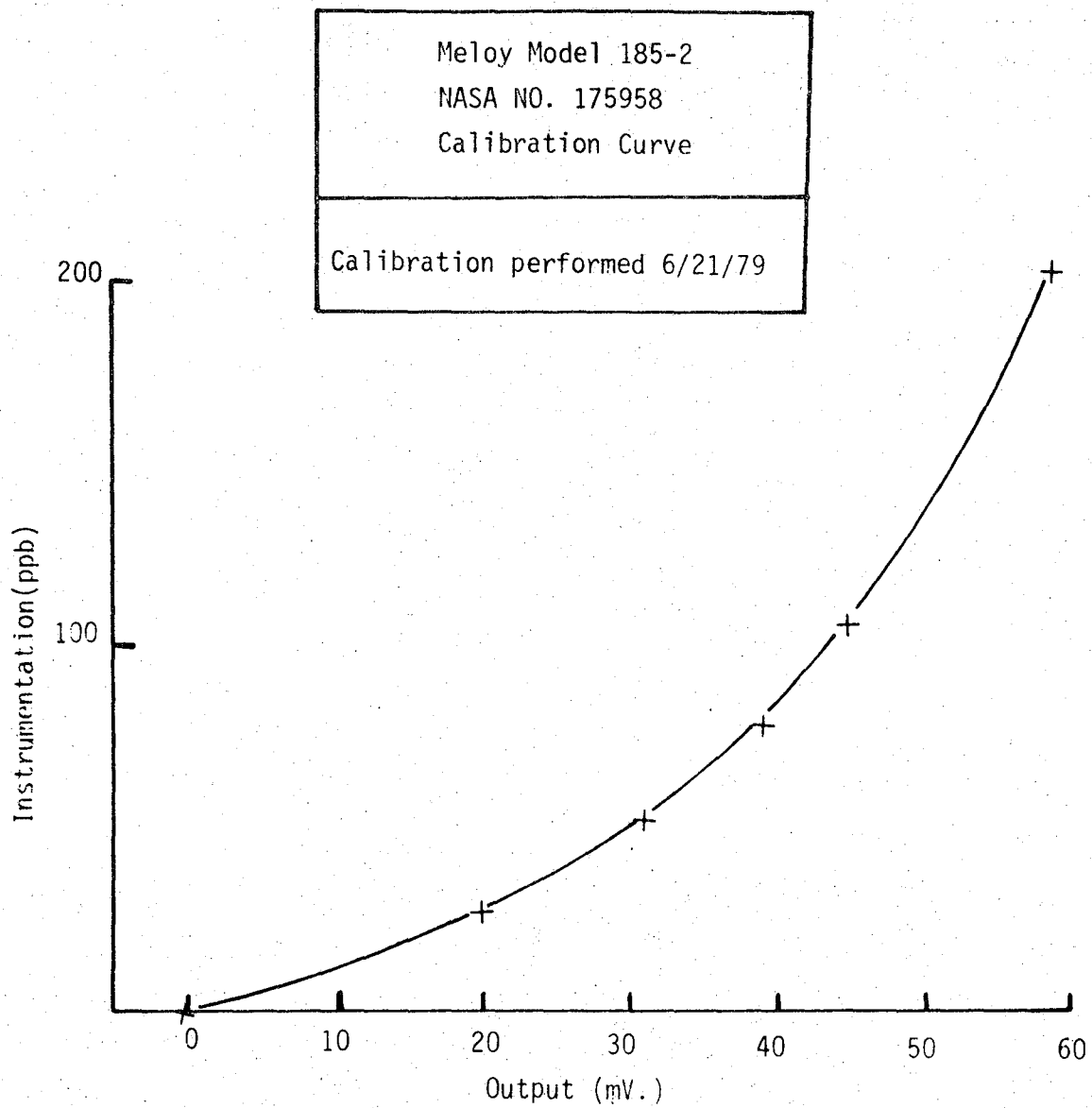

Figure 9 Calibration Curve of Meloy 185 SO<sub>2</sub> Analyzer

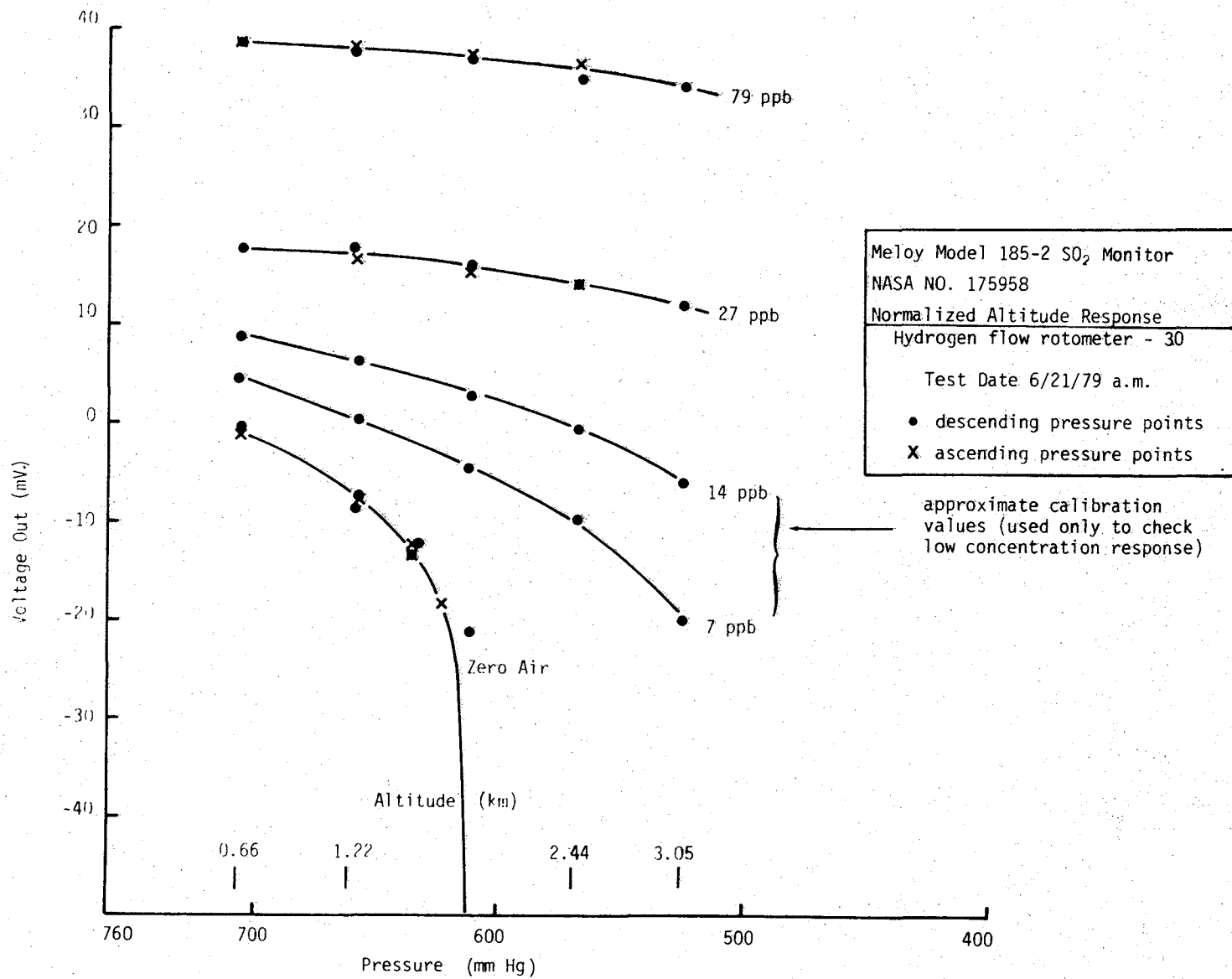

Figure 10 Altitude Response of Meloy 185 SO<sub>2</sub> Analyzer for First Test



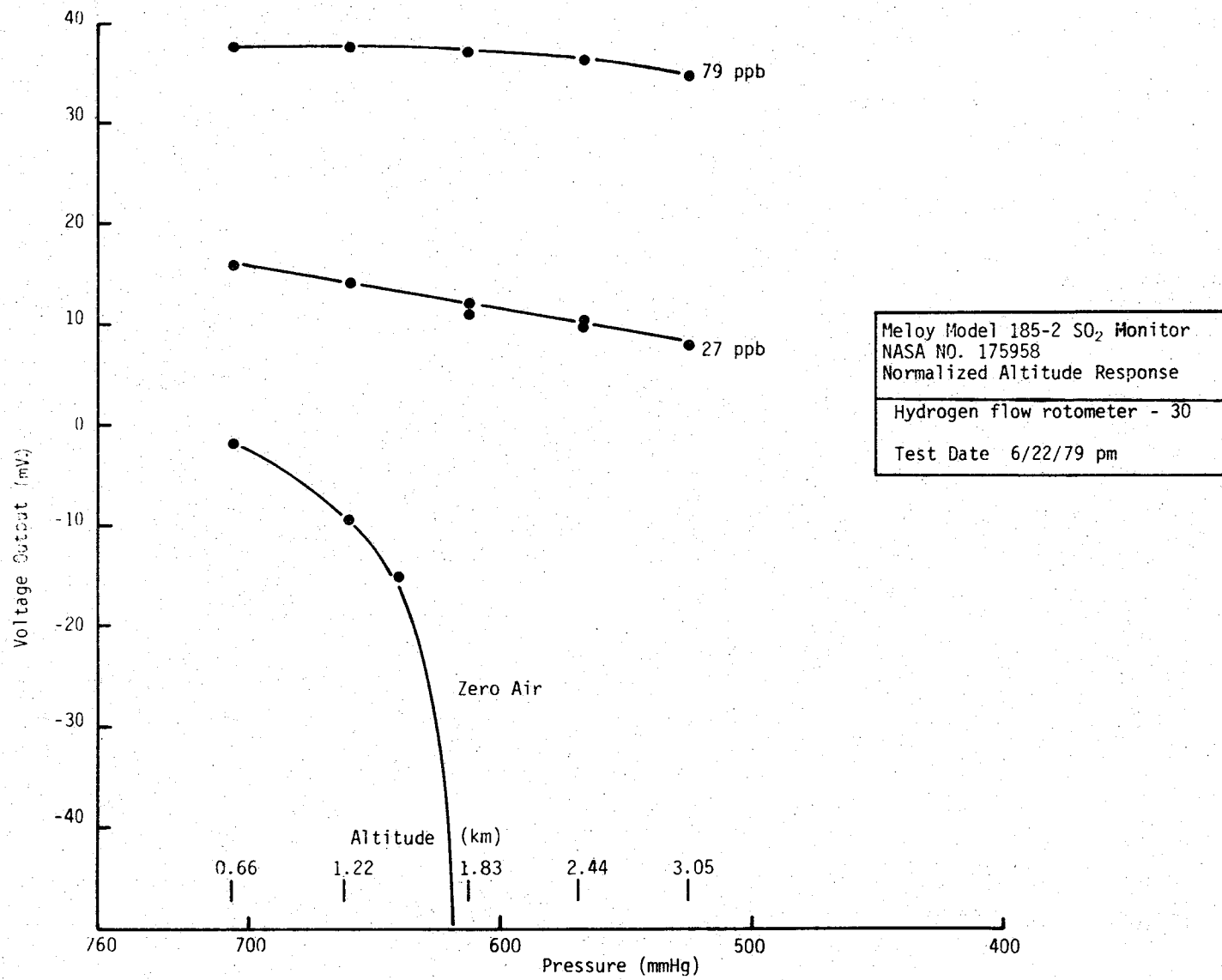

Figure 11 Altitude Response of Meloy 185 SO<sub>2</sub> Analyzer for Second Test

Table 4 DATA FROM ALTITUDE RESPONSE TESTS-MELOY 185 SULFUR MONITOR, NASA NO. 175958

		SO <sub>2</sub> Analyzer Response (mV.)						
		Test #1 6/21/79			Test #2 6/22/79			
Simulated Altitude (km)	Pressure (mmHg)	Concentration			Concentration			
		0	27	79	0	27	79	203
Ambient								
0.66	706	-.3	17.2	38.9	-.2	19.2	39.9	60.3
1.22	659	-8.5	17.2	38.1	-9.4	14.1	37.6	59.8
1.83	612	-66.0	15.7	37.3	-69.5	12.0	37.0	58.8
2.44	567	-69.5	14.2	35.7	-69.5	10.3	35.9	57.8
3.05	525	-69.5	12.0	34.3	-69.5	7.8	34.4	55.8

