



NASA TM-80227

NASA Technical Memorandum 80227

NASA-TM-80227 19800009768

PERFORMANCE ESTIMATES OF A BOEING
747-100 TRANSPORT MATED WITH AN
OUTSIZE CARGO POD

FOR REFERENCE

NOT TO BE TAKEN FROM THIS ROOM

LIBRARY COPY

APR 30 1980

LANGLEY RESEARCH CENTER
LIBRARY, NASA
HAMPTON, VIRGINIA

Lloyd S. Jernell

LIBRARY COPY

February 1980

MAR 12 1980

LANGLEY RESEARCH CENTER
LIBRARY, NASA
HAMPTON, VIRGINIA

NASA

PERFORMANCE ESTIMATES OF A BOEING 747-100
TRANSPORT MATED WITH AN OUTSIZE CARGO POD

Lloyd S. Jerne11
NASA Langley Research Center

SUMMARY

A study has been conducted to determine the design-mission performance of a Boeing 747-100 aircraft mated with an outsize cargo pod. The basic design requirement was the rapid deployment of a combat-loaded mobile bridge launcher from a United States east-coast staging base to Europe. Weight was minimized by stripping the aircraft of unneeded, quick-removal items and by utilizing graphite-epoxy composite materials for most pod components. The mission analysis, based on wind tunnel data and full-scale carrier aircraft and engine data, indicates that for the specified maximum takeoff gross weight of 3,269.44 kN (735,000 lbf) and payload weight of 542.68 kN (122,000 lbf), the maximum range is approximately 7,185 km (3,880 n.mi.). The corresponding air time is about 10.5 hours.

INTRODUCTION

Presently there exists a critical need for increased airlift capability in the long range deployment of outsize cargo during limited-warfare conflicts. Proposals have been made to alleviate this shortfall by providing a stand-by commercial fleet of large wide-body transports modified to carry outsize equipment. However, the overall systems cost of aircraft incorporating such extensive modifications would likely be prohibitively high due primarily to the performance penalties incurred during civil operations.

In order to minimize aircraft modification and the resultant adverse effects on the efficiency of commercial operations, a preliminary study was conducted to determine the feasibility of mating a cargo pod to the underside of a large wide-body aircraft. The primary design-mission requirement was the rapid deployment of outside cargo from a United States east-coast staging base to Europe. A mobile bridge launcher, consisting of launch mechanism and bridge mounted on an M60 tank chassis, was selected as the design payload because it is among the bulkier and heavier items in the military-airlift inventory. Additional design-mission specifications, descriptions of the configurations considered, and the study results are reported in reference 1. Reference 2 presents the results of a subsequent study in which a slightly larger pod was considered for transporting, in addition to outsize military cargo, modular elements of the NASA Spacelab.

Since the pod concept appeared to be feasible, tests were conducted in the Langley V/STOL wind tunnel using a 0.03-scale model of the carrier aircraft with the retractable-gear pod of reference 1. The results are documented in reference 3.

N80-18032 #

The purpose of this paper is to present the results of a detailed analysis of the design mission specified in reference 1, utilizing a Boeing 747-100 carrier aircraft powered by Pratt and Whitney JT9D-7A engines, and a structurally modified version of the retractable-gear pod of reference 1. The data are based on the results of an analysis of the aircraft and pod weights, the wind tunnel data of reference 3, the full-scale carrier aircraft performance data of reference 4, and the engine performance estimates of reference 5.

SYMBOLS

Values are presented in both SI and U.S. customary Units. Measurements and calculations were made in U.S. Customary Units.

C_D	drag coefficient, $\frac{\text{Drag}}{qS}$
$C_{D,p}$	parasite drag coefficient, $\frac{\text{Parasite drag}}{qS}$
$C_{D,p,\min}$	minimum parasite drag coefficient
$C_{D, \text{trim}}$	trimmed drag coefficient, $\frac{\text{Trimmed drag}}{qS}$
C_L	lift coefficient, $\frac{\text{Lift}}{qS}$
CAS	calibrated airspeed
F_n	net thrust
GW	gross weight
g	gravitational constant
h	altitude
M	Mach number
q	dynamic pressure
R	Reynolds number
S	wing reference area
TSFC	thrust specific fuel consumption
V	velocity

DESIGN MISSION

The primary design-mission requirement is that of reference 1; namely, the rapid deployment of a mobile bridge launcher from a United States east-coast staging base to Europe. The payload weight, which includes the combat-loaded vehicle and the necessary shoring equipment, is 542.68 kN (122,000 lbf). It was also specified that the pod be unpressurized in order to simplify construction and to minimize cost and weight. Hence, according to military specifications for unpressurized cargo, maximum altitude is limited to 5.486 km (18,000 ft).

CONFIGURATION

A three-view drawing of the configuration with full-scale dimensions is presented in figure 1. An isometric view showing additional details of the pod is provided in figure 2.

Carrier Aircraft

Because of the mission payload and range requirements, the only current commercial transports suitable for adaptation to the cargo-pod concept are Boeing 747 aircraft at the -100 and -200 series. According to reference 6, as of year-end 1978 U.S. airlines had in operation 94 transports of the -100 series and 13 of the -200 series. Since aircraft of the former series have less fuel capacity and lower maximum takeoff gross weights, a conservative approach was taken by selecting for the carrier aircraft role a typically configured 747-100 powered by Pratt and Whitney JT9D-7A engines. In the early stages of preliminary design it became apparent that the operating empty weight of the combined aircraft and pod could be critical for the specified design mission. Thus considerable attention was devoted to weight reduction, including stripping the carrier aircraft of items which are not essential to the military mission and which can be removed in a relatively short time. These items include the landing gear, seats, galleys, and passenger-emergency equipment.

Pod

In the study of reference 1, which considered an all-metal pod structure and the bridge launcher as design payload, the weight of the retractable-gear pod was estimated to be 212.18 kN (47,700 lbf). However, subsequent studies using the structural-design criteria and improved computer methods of reference 2 indicated that the all-metal pod weight can be reduced to 195.81 kN (44,020 lbf). A cursory follow-on study was conducted to determine the potential for the further reduction in pod weight by the utilization of composite materials. Based on the allowable-stress data and analysis methods of reference 7, graphite-epoxy material was selected. The results indicated that this material could be used for essentially all components of the pod body and much of the landing gear, with an attendant 15- to 20-percent reduction in pod total weight.

The present study assumes maximum utilization of composite materials for pod construction and a resulting weight reduction of 15 percent from the refined all-metal estimate. Hence, the weight of the pod employed herein is estimated to be 166.45 kN (37,420 lbf). A summary of the weights for this configuration is presented in Table 1.

MISSION ANALYSIS

The trimmed lift-drag polars, as determined from the wind tunnel data of reference 3 and the estimated variations in parasite drag coefficient $C_{D,p}$ with lift coefficient, are presented in figures 3(a) and 3(b) for the pod-off and pod-on configurations, respectively. The center of gravity is located at the quarter-chord point of the wing mean aerodynamic chord. The Reynolds number is 1.08×10^6 .

Variations of minimum parasite drag coefficient $C_{D,p,min}$ with Reynolds number are shown in figure 4. For both configurations, the drag estimates of reference 1 were greater than were determined from the wind tunnel data of reference 3. Rather than using the model data with the greater extrapolation to flight Reynolds numbers, the present pod-off $C_{D,p,min}$ for the cruise Reynolds number range was obtained by utilizing the full-scale aircraft and engine performance data of references 4 and 5. It will be noted that these values are somewhat higher than those of reference 1. The pod-on $C_{D,p,min}$ used in the mission analysis was assumed to be equal to the pod-off value plus the increase due to the pod as estimated by reference 1.

The design-mission weights, time, and range, which were calculated for a takeoff gross weight of 3,269.44 kN (735,000 lbf) using Military Airlift Command long-range fuel reserves, are presented in Table II. Pod-on aerodynamic characteristics were not available for the takeoff and first-segment climb configurations. Therefore, it was assumed that for these segments, the pod-on and pod-off fuel burn, distance, and air time were in proportion to those calculated for the second-segment climb. Since fuel burn for the second segment is partly a function of gross weight, and thus affected by the amount of fuel consumed during takeoff and the first-segment climb, iterative calculations were required.

The second-segment climb schedule, shown in figure 5 in terms of Mach number variation with altitude, consists of a climb at 463 km/hr (250 kts) calibrated airspeed CAS from an altitude of 0.46 km (1,500 ft) to 3.05 km (10,000 ft). This climb is followed by an acceleration, and then a continued climb at 593 km/hr (320 kts) CAS to 5.49 km (18,000 ft).

Uninstalled thrust values for the JT9D-7A engine at maximum climb rating, ICAO standard atmosphere, were obtained from reference 5. The values were then assessed a 3-percent penalty for installation, air bleed, and power extraction to determine the estimated installed climb thrust. The rate of climb $\frac{dh}{dt}$ was obtained from

$$\frac{dh}{dt} = \frac{v \left(\frac{F_n - D}{GW} \right)}{1 + \frac{v}{g} \frac{dv}{dt}}$$

The resulting values, as affected by altitude and gross weight, are provided in figure 6. The variation of fuel flow rate with altitude for the second-segment climb, as determined from reference 5, is shown in figure 7.

The effects of thrust and Mach number on thrust specific fuel consumption, TSFC, at the design cruise altitude are shown in figure 8. As before, a 3-percent penalty was applied to the data of reference 5 to obtain the installed engine performance. Cruise performance calculations, in which Mach number was optimized for maximum range, were determined in fuel-burn increments of approximately 88.96 kN (20,000 lbf). The effect of gross weight on cruise Mach number is shown in figure 9. Using the gross weights of Table II, it will be noted that the optimum Mach number varies approximately linearly from an initial value of 0.675 to an end-of-cruise value of 0.550. Descent, approach, and landing performance were estimated using the data of reference 4, with adjustments to account for pod effects as determined from figures 3 and 4.

The design-mission fuel reserves (see Table II) were computed to meet the long-range mission requirements specified by the Military Airlift Command. Figure 10 shows the effect of gross weight on minimum-drag holding Mach number at cruise altitude. These data, together with the specific fuel consumption values to figure 8, were used to calculate the fuel required to hold at maximum endurance.

The mission analysis indicates that for the assumed maximum takeoff gross weight of 3,269.44 kN (735,000 lbf) the design-mission maximum range is approximately 7,185 km (3,880 n.mi.). The corresponding air time is about 10.5 hours.

CONCLUDING REMARKS

A study has been conducted to determine the design-mission performance of a Boeing 747-100 aircraft mated with an outsize cargo pod. The basic design requirement was the rapid deployment of a combat-loaded mobile bridge launcher from a United States east-coast staging base to Europe. Weight was minimized by stripping the aircraft of unneeded, quick-removal items and by utilizing graphite-epoxy composite materials for most pod components. The mission analysis, based on wind tunnel data and full-scale carrier aircraft and engine data, indicates that for the specified maximum takeoff gross weight of 3,269.44 kN (735,000 lbf) and payload weight of 542.68 kN (122,000 lbf), the maximum range is approximately 7,185 km (3,880 n.mi.). The corresponding air time is about 10.5 hours.

REFERENCES

1. Quartero, C. B.; Washburn, G. F.; and Price, J. E.: Boeing 747 Aircraft With External Cargo Pod. NASA CR-158932, 1978.
2. Price, J. E.; Quartero, C. B.; Smith, P. M.; and Washburn, G. F.: Boeing 747 Aircraft With Large External Pod for Transporting Outsize Cargo. NASA CR-159067, 1979.
3. Jernell, Lloyd S.; and Croom, Delwin R.: Effects of a Military Cargo Pod and Tail Fins on the Aerodynamic Characteristics of a Large Wide-body Transport Model. NASA TM 80052, 1979.
4. The Boeing Company: Performance of the Boeing Transport Models 747SR, 747-200B, -200C, -200F, and 747-100 with JT9D-7 Engines and JT9D-7A Engines. D6-33382, 1972.
5. Pratt and Whitney Aircraft Division, United Technologies Corporation: JT9D Commercial Turbofan Engine Installation Handbook. Marketing Support. 1967. (Revised August 1975.)
6. The Boeing Company: Jet Airplane Fleets of the World, Year-End 1978. Y8453. June 1979.
7. Third Conference on Fibrous Composites in Flight Vehicle Design - Part I. NASA TM X-3377, 1976.

TABLE I.- WEIGHTS SUMMARY; BOEING 747-100 WITH JT9D-7A ENGINES

(a) Maximum design- and performance-limited weights

	kN	lbf
Taxi	3,282.79	738,000
Takeoff gross (maximum certified)	3,269.44	735,000
Zero fuel	2,341.99	526,500
Fuel	1,406.97	316,300
Landing	2,508.80	564,000

(b) Aircraft/pod design-mission weight breakdown

	kN	lbf
Structure	808.24	181,700
Landing gear	0	0
Propulsion	202.79	45,500
Systems	111.65	25,100
Furnishings	62.28	14,000
Paint	3.11	700
Manufacturer's empty weight	1,188.08	267,090
Standard and operational items	9.03	2,030
Operating empty weight, aircraft only	1,197.11	269,120
Pod	166.45	37,420
Operating empty weight, aircraft with pod	1,363.56	306,540
Payload	542.68	122,000
Zero fuel weight	1,906.24	428,540
Fuel at brake release	1,363.20	306,460
Takeoff gross weight	3,269.44	735,000

TABLE II.- MISSION PERFORMANCE; BOEING 747-100 WITH POD, JT9D-7A ENGINES

Mission segment	Gross weight kN (lbf)	Fuel remaining kN (lbf)	Σ Air time hr	Σ Range km (n. mi.)
Takeoff	3,269.44 (735,000)	1,363.20 (306,460)	0	0 (0)
First segment climb	3,264.24 (733,830)	1,358.00 (305,290)	.02	0 (0)
Second segment climb	3,254.36 (731,610)	1,348.12 (303,070)	.06	17 (9)
Cruise	3,203.43 (720,160)	1,297.19 (291,620)	.30	169 (91)
Descent	2,090.09 (469,870)	183.85 (41,330)	10.25	7,106 (3,837)
Approach and land	2,085.59 (468,860)	179.35 (40,320)	10.39	7,189 (3,882)
	2,078.39 (467,240)	172.15 (38,700)	10.47	7,189 (3,882)

Reserves (Military Airlift Command):

10 percent trip air time (not to exceed 1 hr.), kN (lbf)	85.85 (19,300)
Hold at 5.486 km (18,000 ft) for 1 hr, 10 min; kN (lbf)	86.30 (19,400)
Total reserves, kN (lbf)	172.15 (38,700)

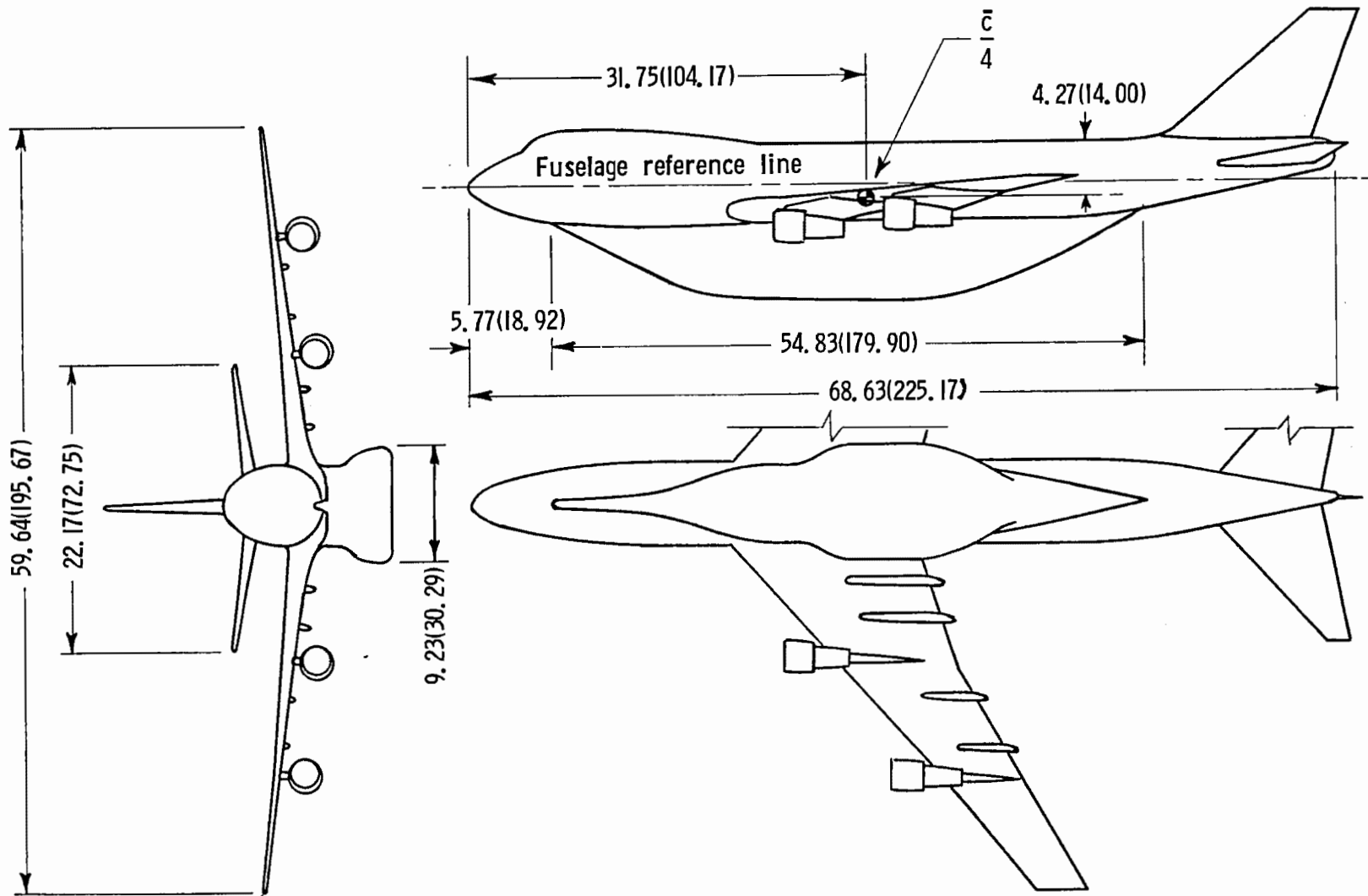

Figure I. - Configuration geometry. Full-scale dimensions are in meters, with feet in parentheses.

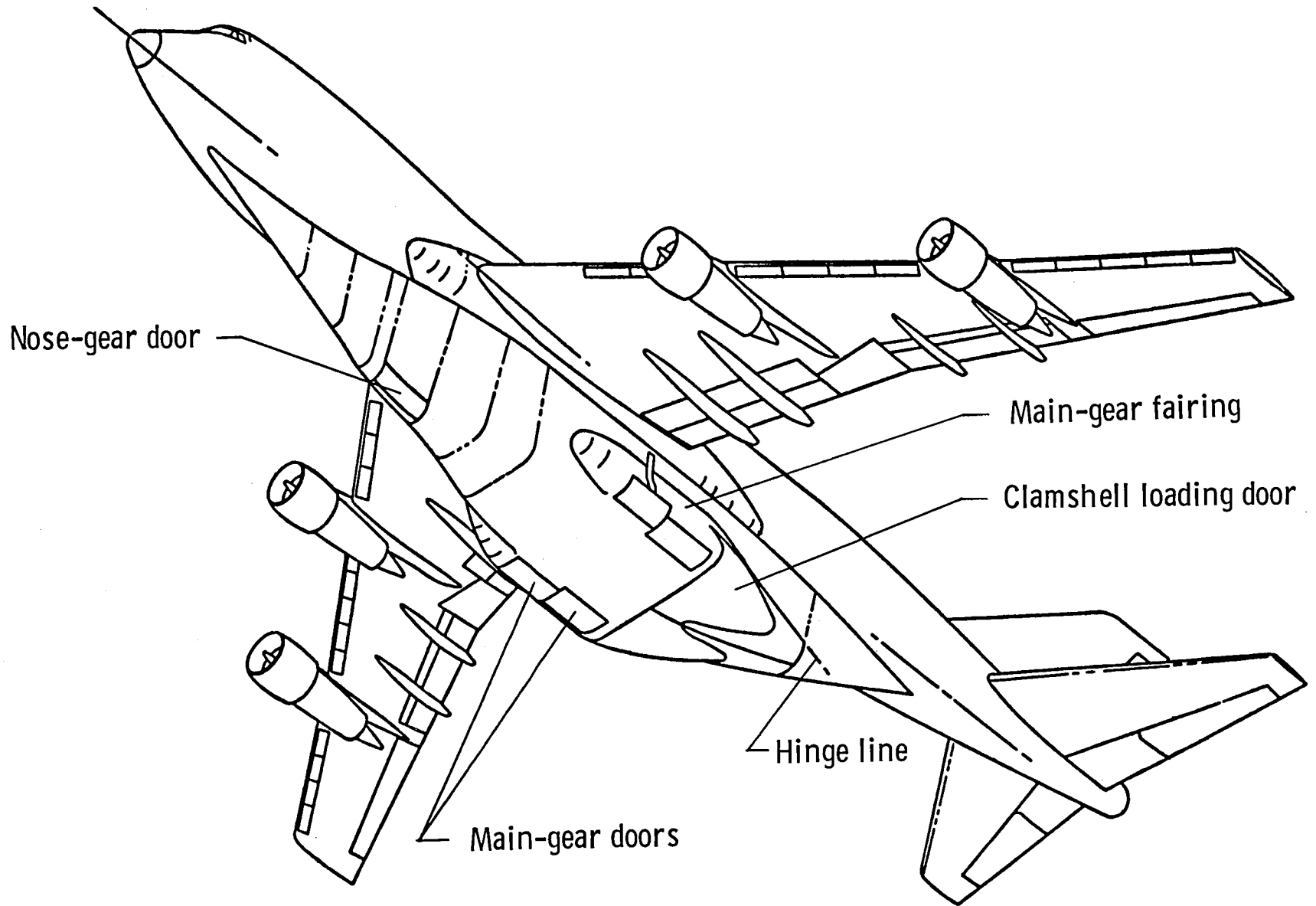
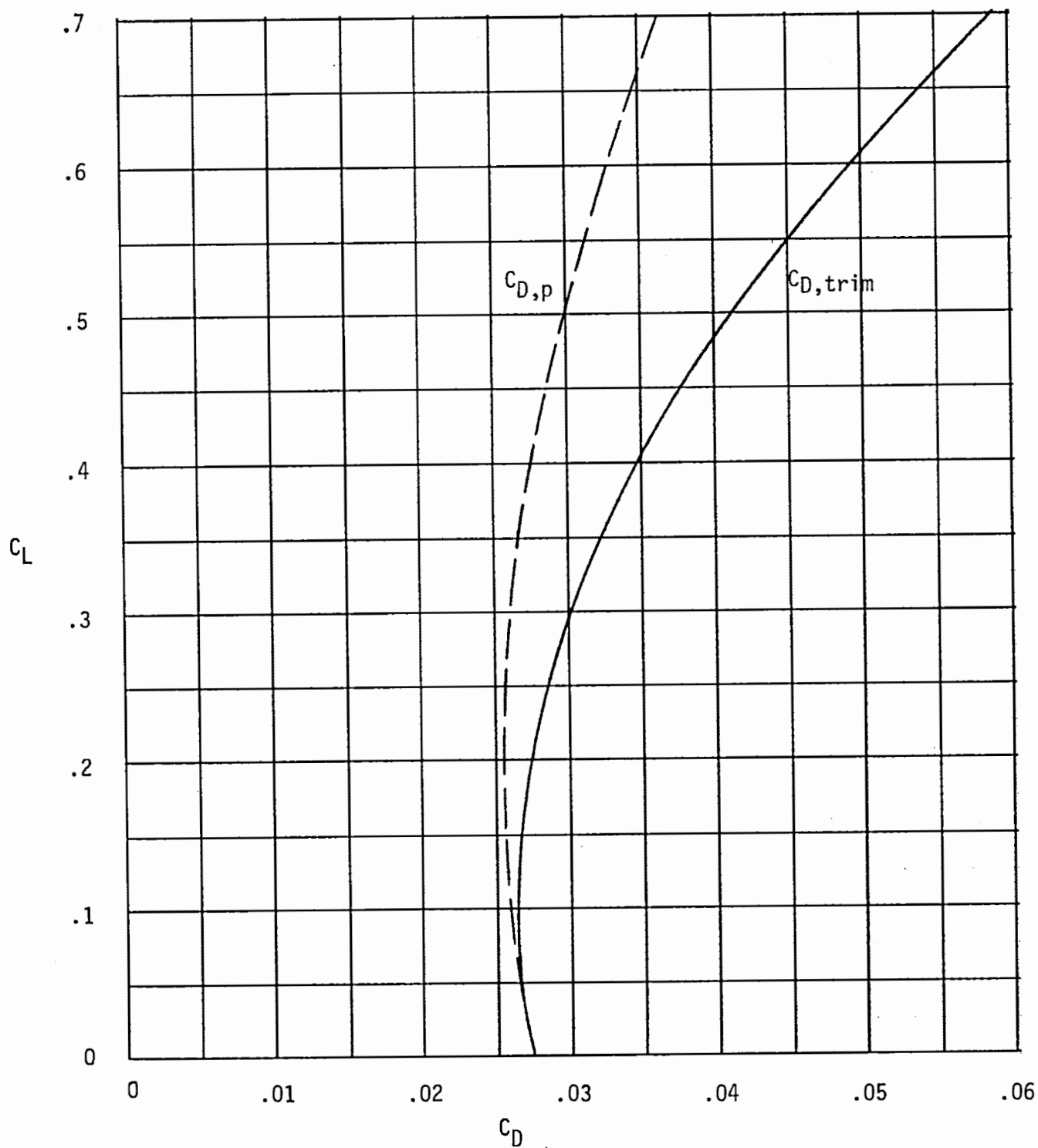
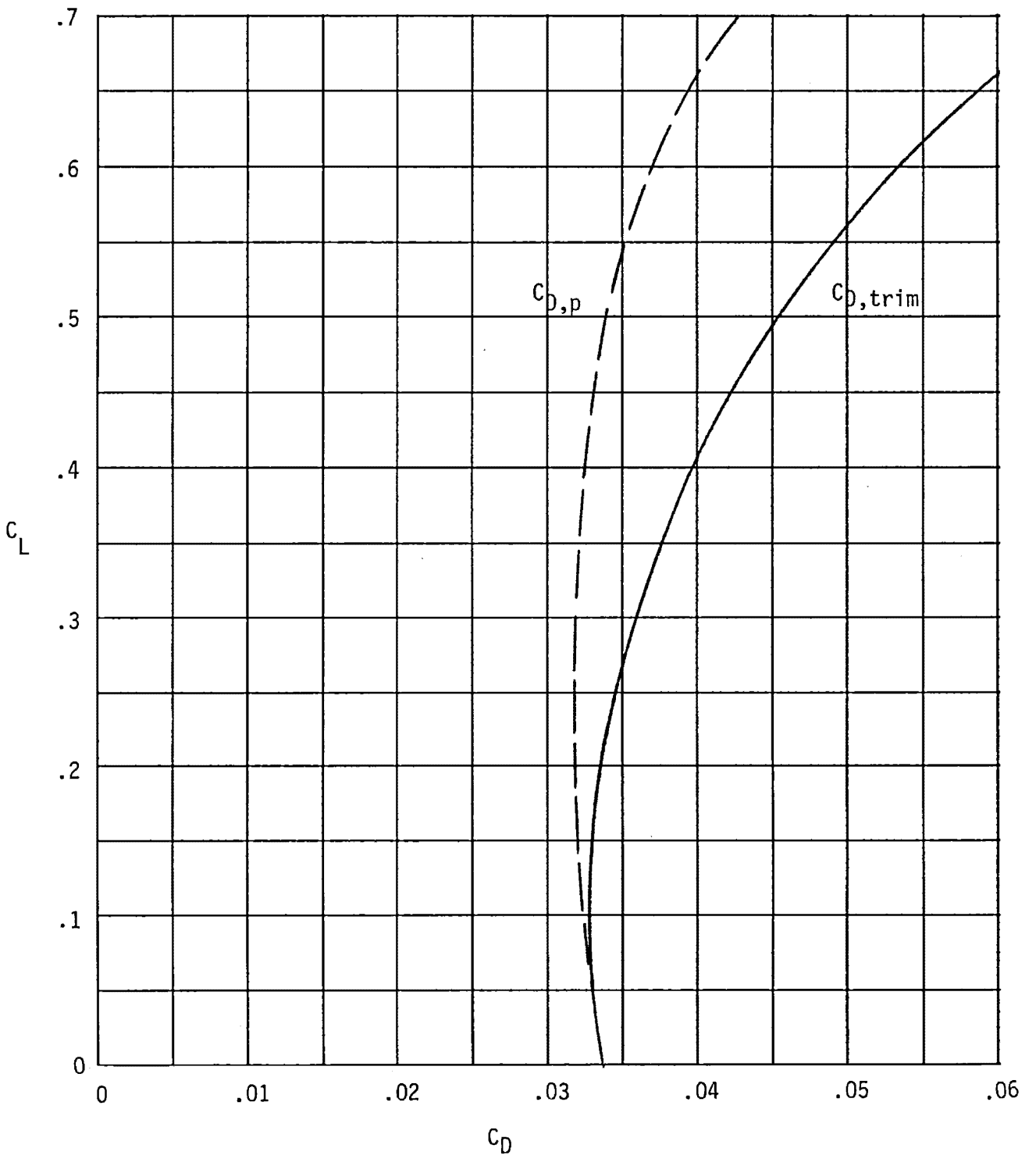

Figure 2. - Configuration isometric view.



(a) Pod off.

Figure 3. - Wind tunnel trimmed lift-drag polar and estimated parasite drag coefficient; c.g. at $0.25 \bar{c}$; $R = 1.08 \times 10^6$.



(b) Pod on.

Figure 3. - Concluded.

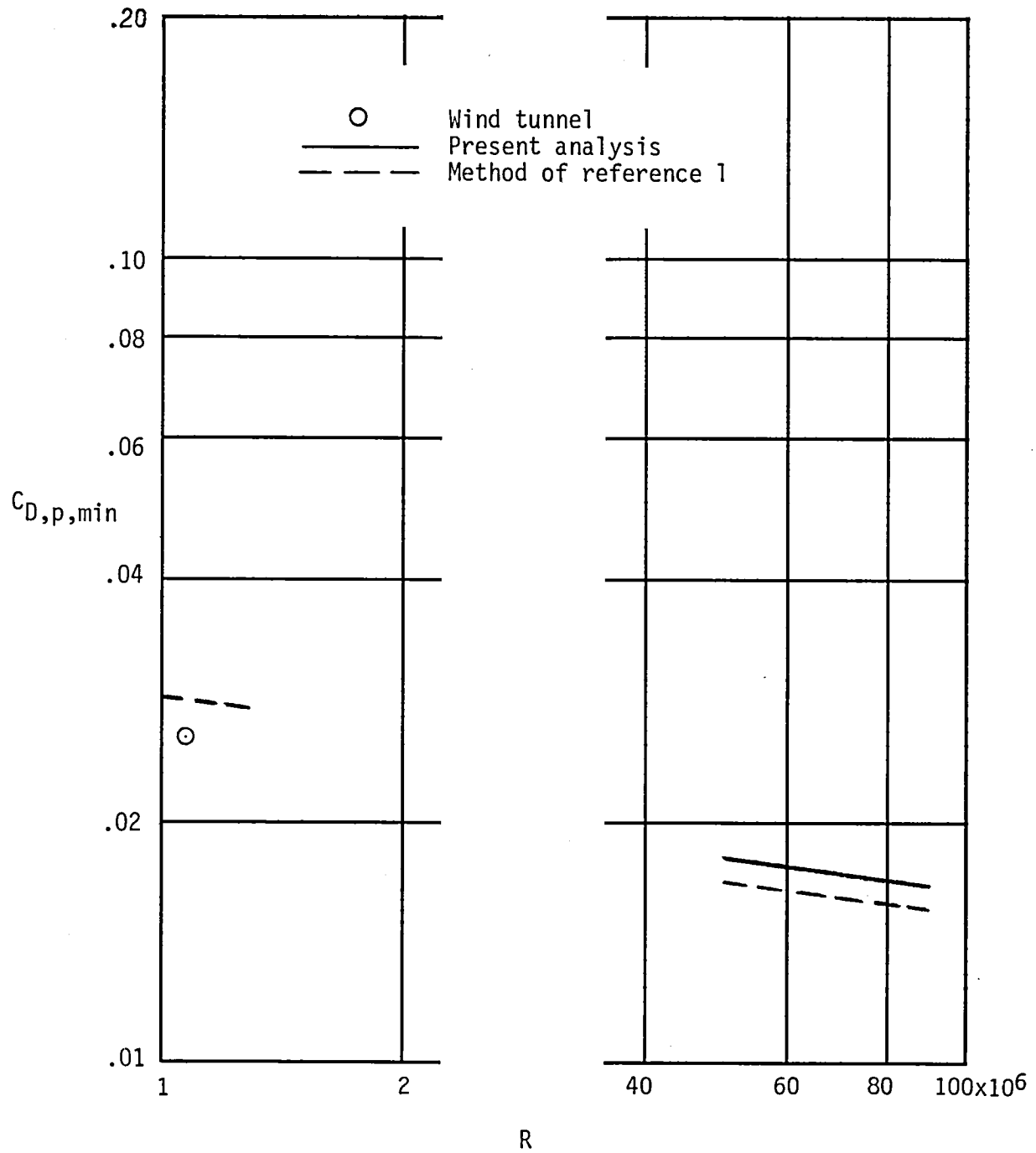

(a) Pod off.

Figure 4. - Effect of Reynolds number on minimum parasite drag coefficient.

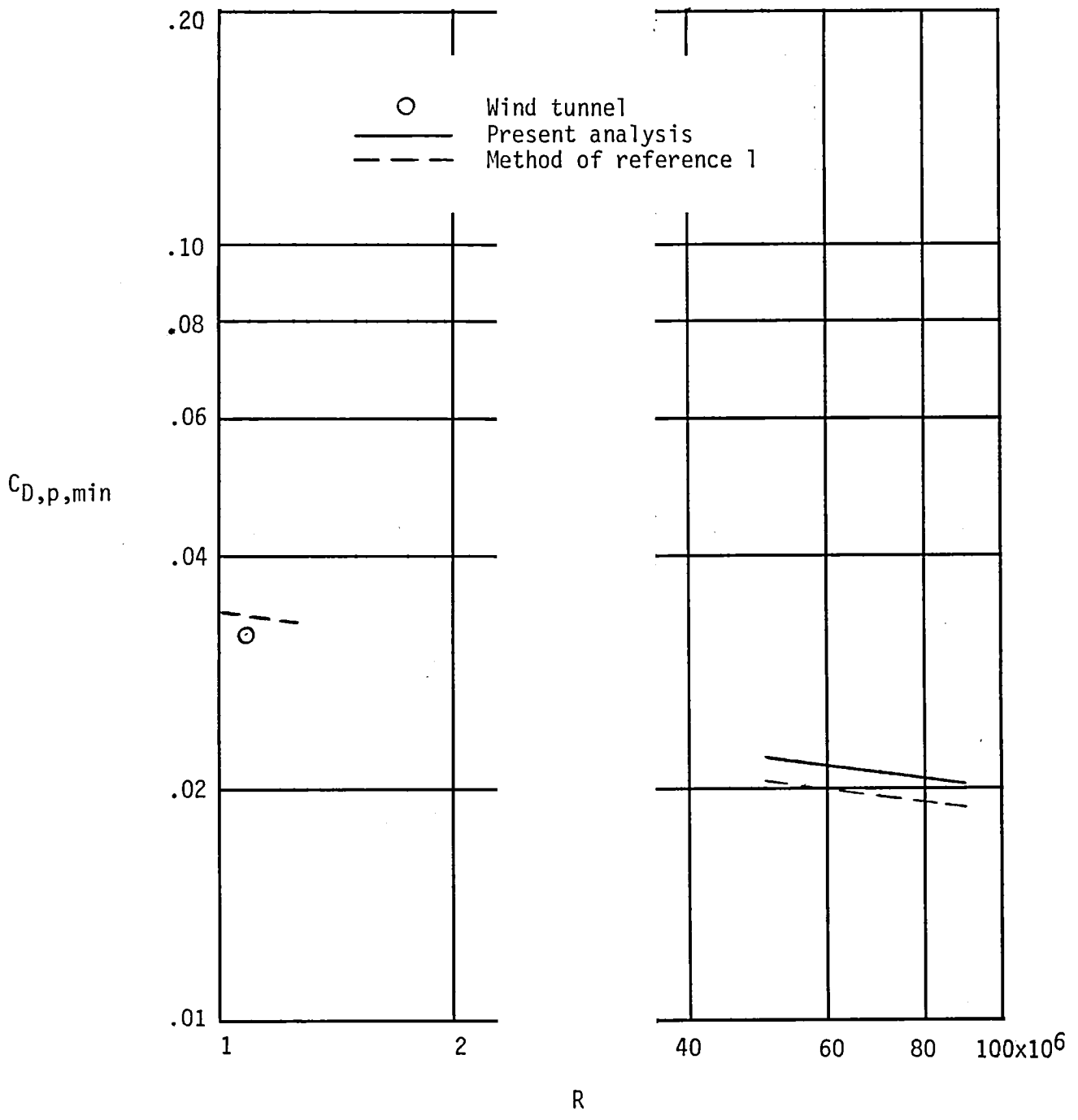

(b) Pod on.

Figure 4. - Concluded.

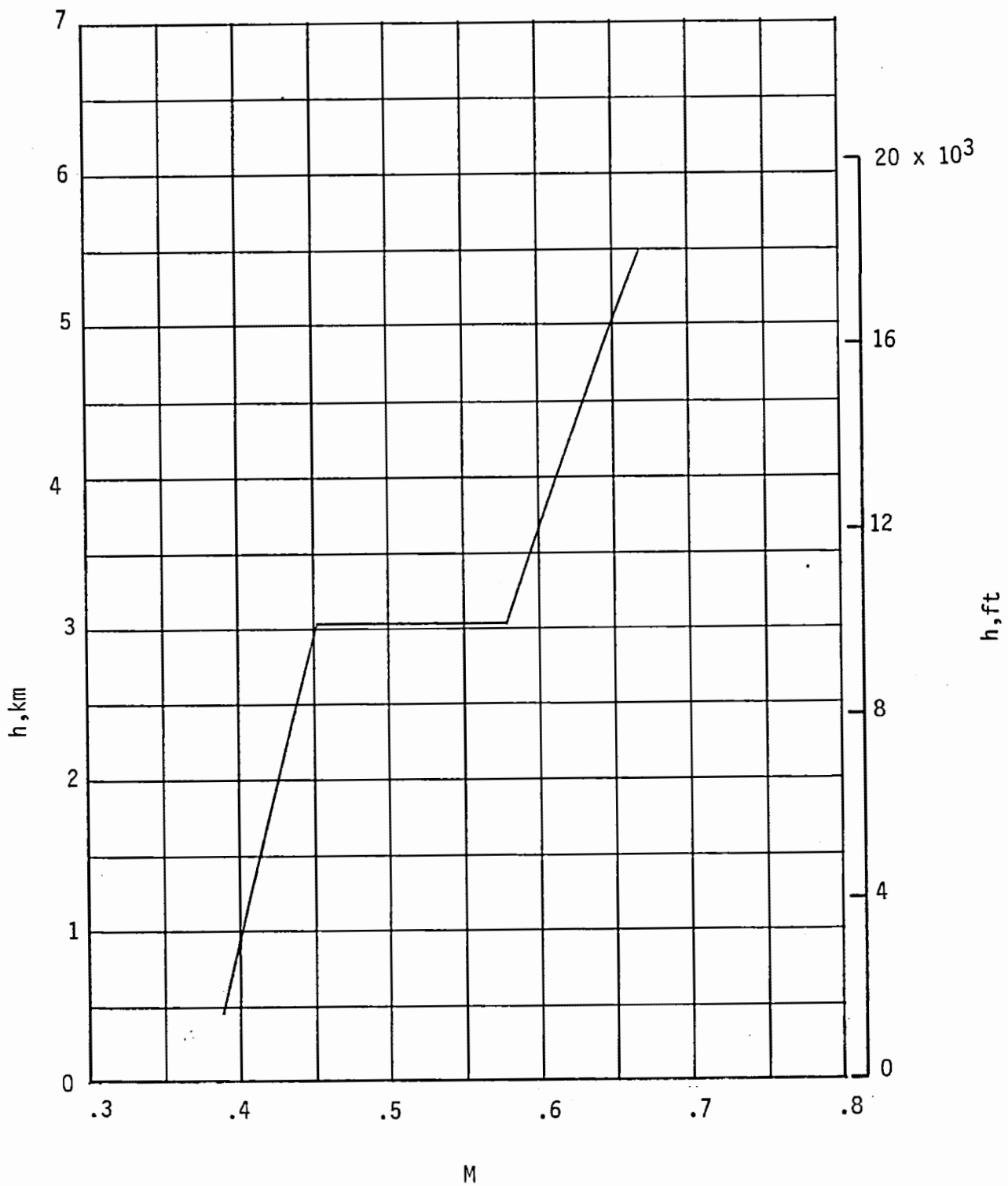

Figure 5. - Variation of Mach number with altitude during second-segment climb.

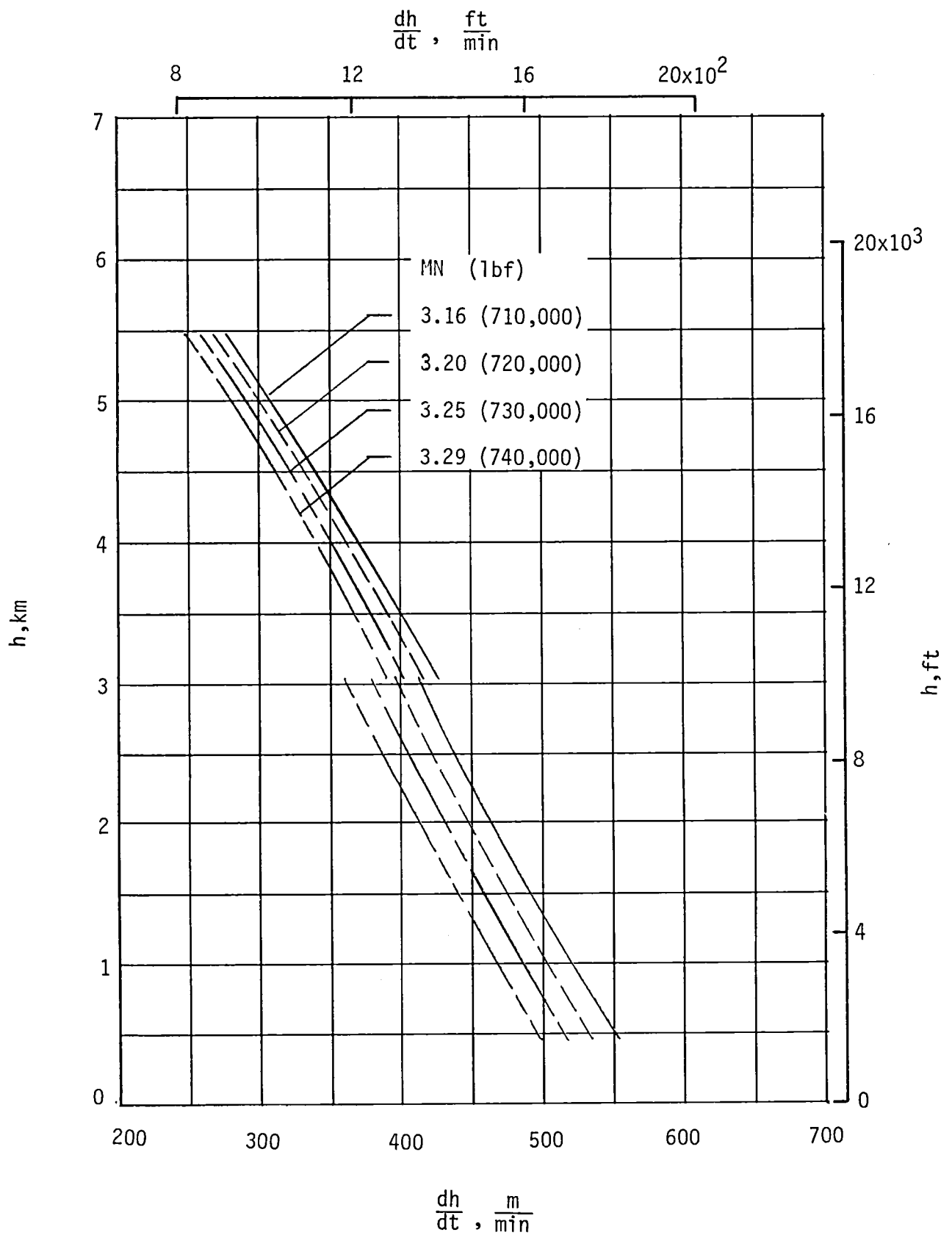

Figure 6. - Rate of climb for engine maximum-climb rating.

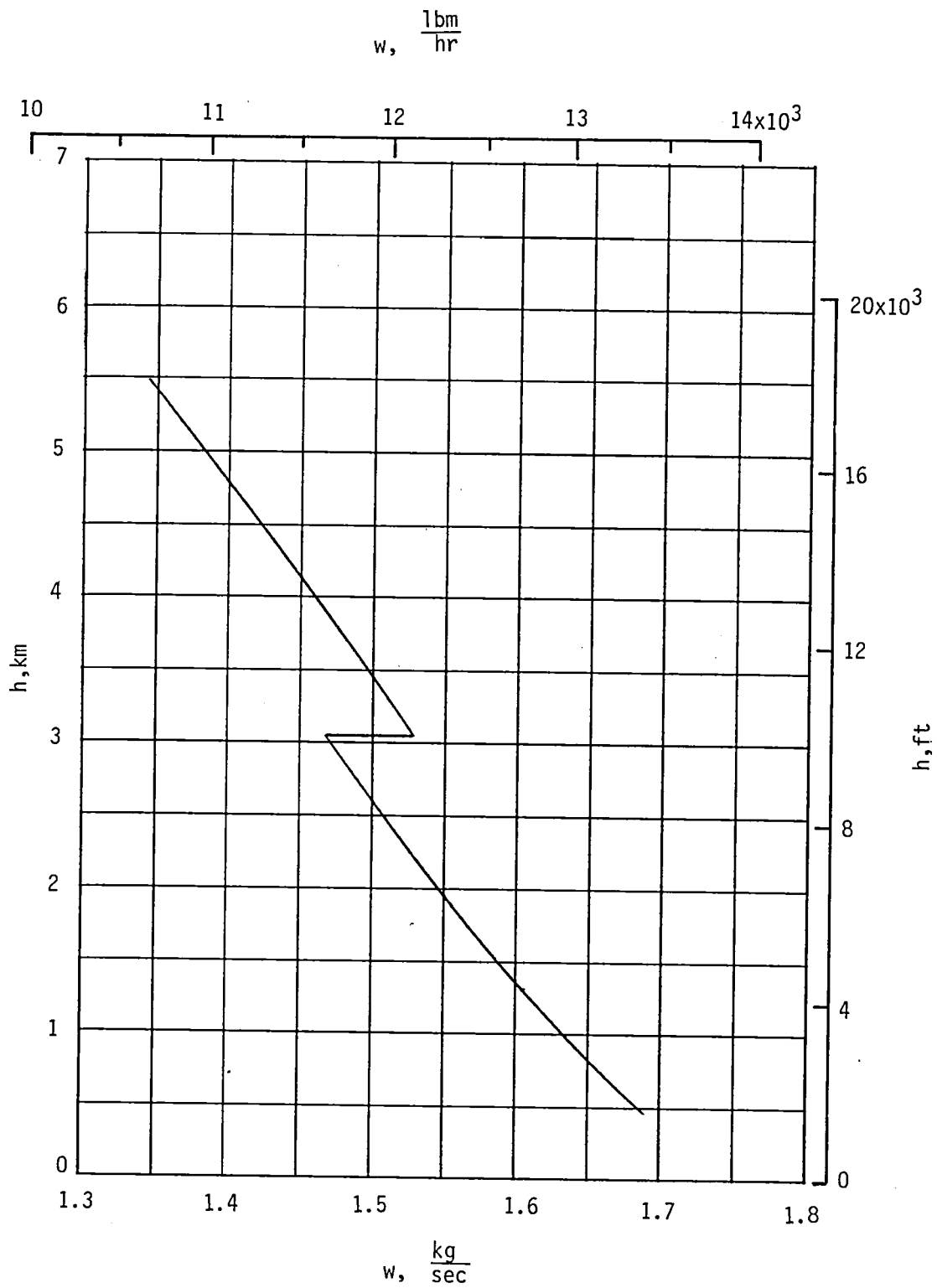

Figure 7. - Variation of fuel flow rate per engine with altitude for engine maximum-climb rating.

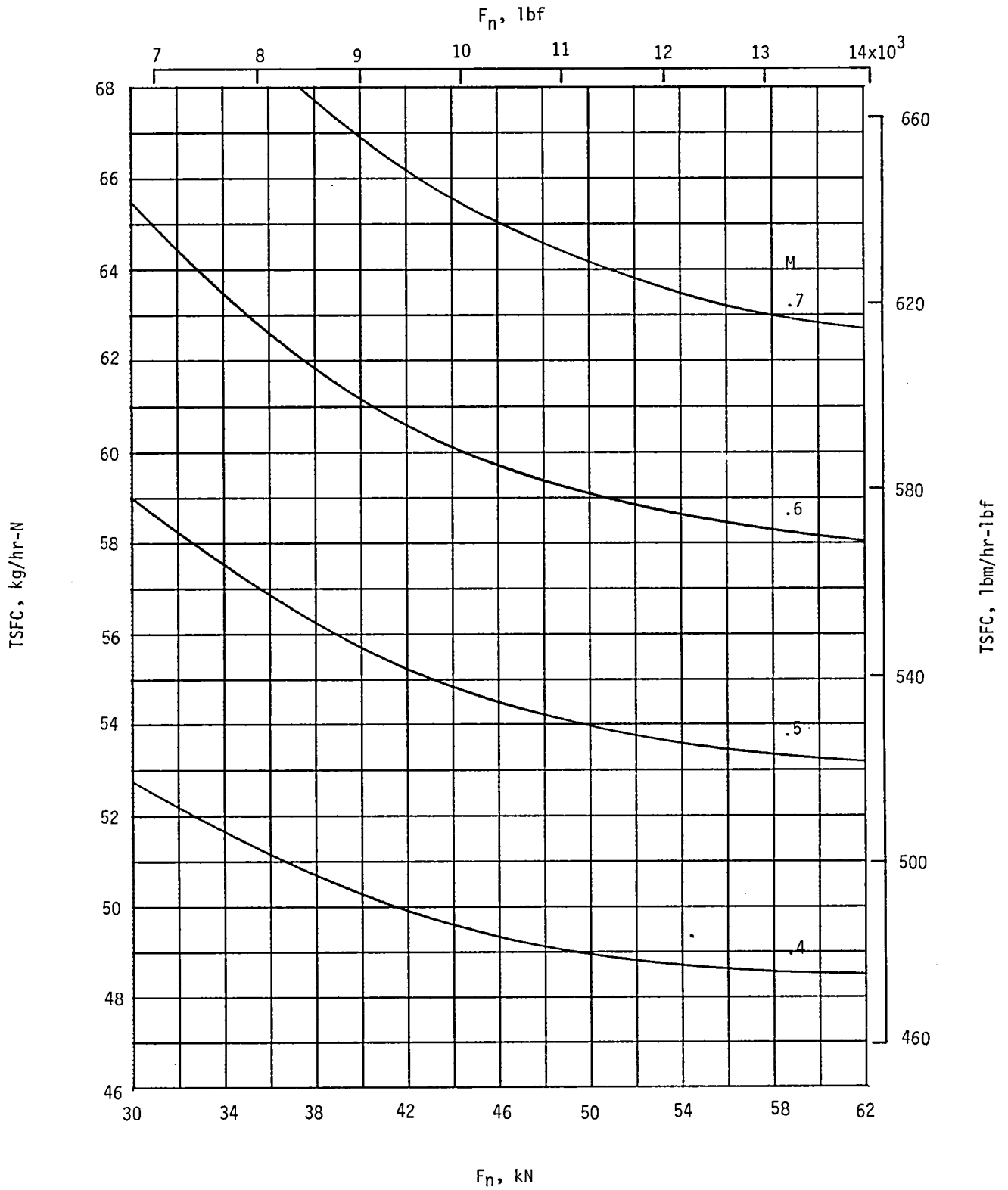

Figure 8. - Thrust specific fuel consumption; 5.486 km (18,000 ft) altitude.

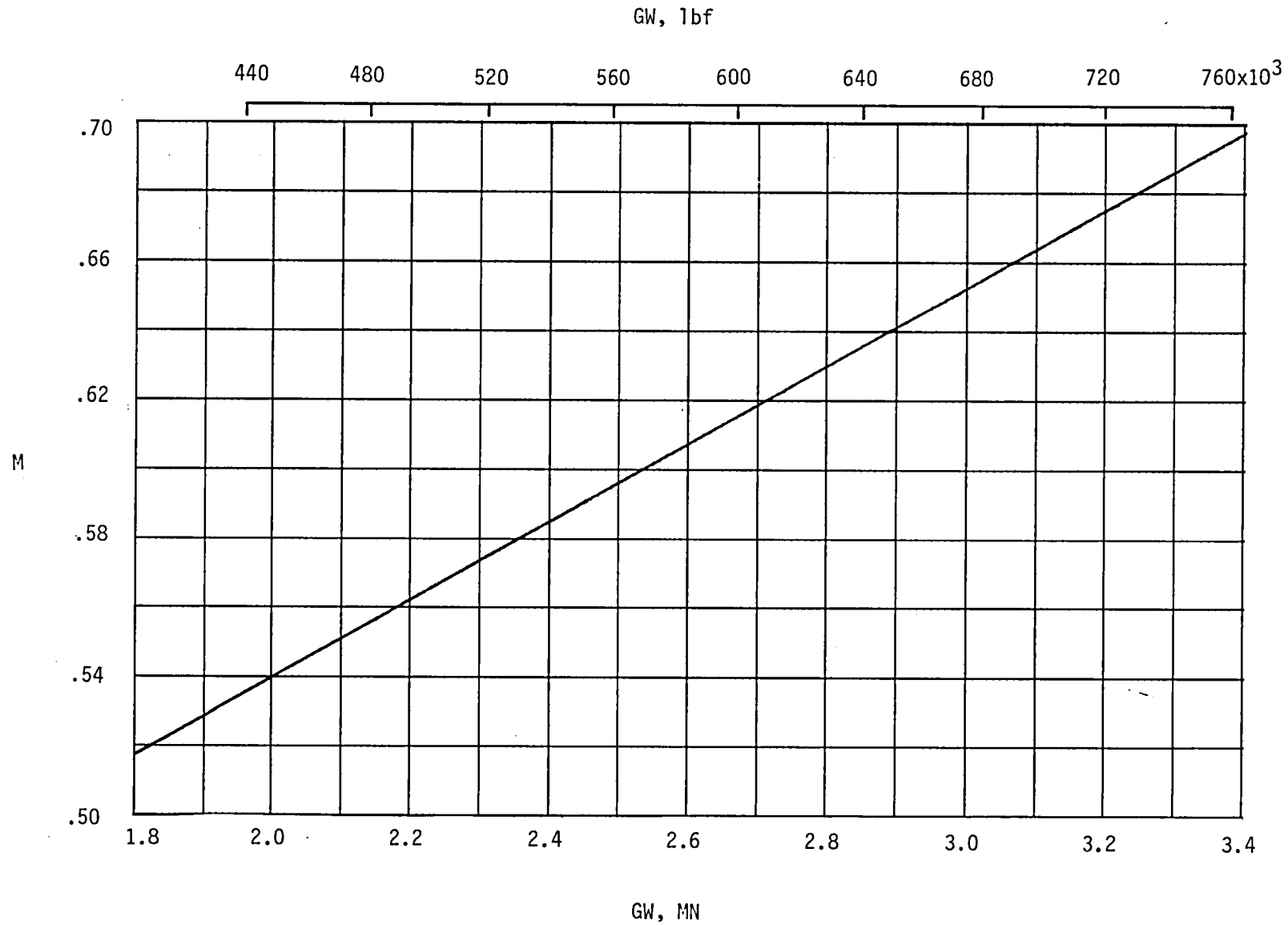

Figure 9. - Effect of gross weight on maximum-range cruise Mach number; 5.486 km (18,000 ft) altitude.

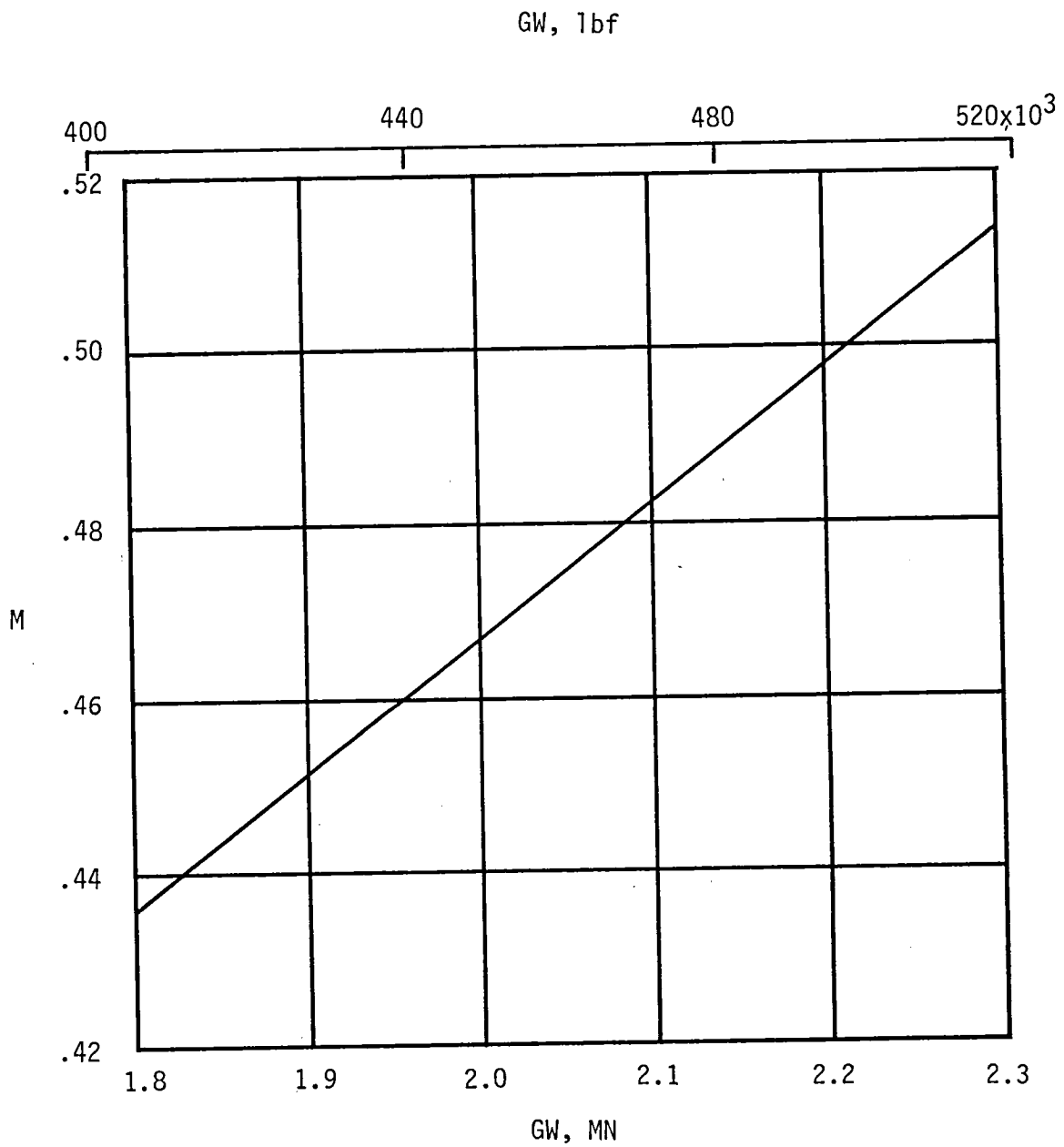

Figure 10. - Effect of gross weight on minimum-drag holding Mach number; 5.486 km (18,000 ft) altitude.

1. Report No. NASA TM-80227		2. Government Accession No.		3. Recipient's Catalog No.	
4. Title and Subtitle Performance Estimates of a Boeing 747-100 Transport Mated With an Outsize Cargo Pod				5. Report Date February 1980	
				6. Performing Organization Code	
7. Author(s) Lloyd S. Jernell				8. Performing Organization Report No.	
9. Performing Organization Name and Address NASA Langley Research Center Hampton, Virginia 23665				10. Work Unit No. 530-04-13-01	
				11. Contract or Grant No.	
12. Sponsoring Agency Name and Address National Aeronautics and Space Administration Washington, DC 20546				13. Type of Report and Period Covered Technical Memorandum	
				14. Army Project No.	
15. Supplementary Notes					
16. Abstract A study has been conducted to determine the design-mission performance of a Boeing 747-100 aircraft mated with an outsize cargo pod. The basic design requirement was the rapid deployment of a combat-loaded mobile bridge launcher from a United States east-coast staging base to Europe. Weight was minimized by stripping the aircraft of unneeded, quick-removal items and by utilizing graphite-epoxy composite materials for most pod components. The mission analysis, based on wind tunnel data and full-scale carrier aircraft and engine data, indicates that for the specified maximum takeoff gross weight of 3,269.44 kN (735,000 lbf) and payload weight of 542.68 kN (122,000 lbf), the maximum range is approximately 7,185 km (3,880 n.mi.). The corresponding air time is about 10.5 hours.					
17. Key Words (Suggested by Author(s)) Large military cargo pod Aircraft/cargo pod integration			18. Distribution Statement UNCLASSIFIED - UNLIMITED STAR CATEGORY 05		
19. Security Classif. (of this report) UNCLASSIFIED		20. Security Classif. (of this page) UNCLASSIFIED		21. No. of Pages 20	22. Price* \$4.00

