

^{D2}
N80-19147

ADVANCED SUNFLOWER ANTENNA
CONCEPT DEVELOPMENT

J. S. Archer
TRW

LSST 1ST ANNUAL TECHNICAL REVIEW

November 7-8, 1979

This report is a summary of the results of a study performed at TRW to determine the feasibility of stowing large solid antenna reflectors in the shuttle using the Advanced Sunflower Concept developed at TRW. This work was sponsored by JPL as part of its study of precision self-deployable antenna systems, which in turn is part of the NASA Large Space Systems Technology (LSST) program.

~~BASE~~ 32 INTENTIONALLY BLANK

11 18 5087

STOWED REFLECTOR CONFIGURATION

The basic deployment concept was originally developed at TRW to meet the requirement for large diameter ($D/\lambda > 1000$), high accuracy reflectors to be used in the 10 to 100 GHz range or higher, within the constraints of the shuttle.

The folded petal concept provides hinged connections along adjacent edges of all panels. Bending and shear continuity is thereby provided throughout the contour in the deployed aspect. All elements are released and deployed simultaneously.

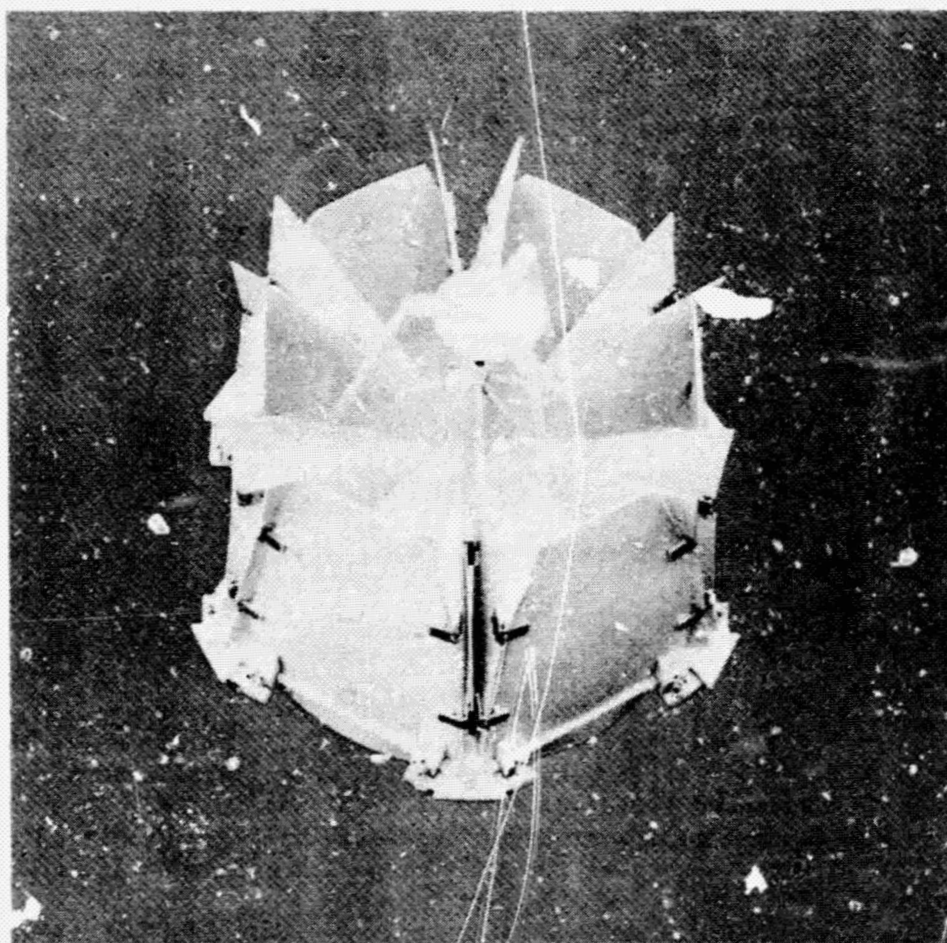

ORIGINAL PAGE IS
OF POOR QUALITY

WORK STATEMENT TASKS

The study focused on two major tasks. The first was to conduct an investigation of the original deployment concepts, including the following:

1. Determine the largest antenna of this design stowable in the shuttle payload compartment.
2. Determine the upper boundary for surface quality vs. antenna diameter.
3. Determine packing efficiency and weight vs. diameter.
4. Develop ROM cost estimate vs. diameter and surface quality.
5. Perform the above tasks for offset fed antennas.
6. Identify critical technologies required for construction of these antennas.

The second task involved the development of advanced designs which would allow antennas up to 100 feet in diameter to be accommodated by the shuttle. The same information as in the first task was to be obtained for the most promising of these designs.

PRECISION DEPLOYABLE REFLECTOR STUDY FOR JPL, NASA LANGLEY WORK STATEMENT TASKS

- DETERMINE LARGEST DIAMETER REFLECTOR THAT CAN BE STOWED IN SHUTTLE - CURRENT CONFIGURATION
- ESTIMATE SURFACE CONTOUR ACCURACY FOR A RANGE OF SIZES - CURRENT CONFIGURATION
- ESTIMATE ROM COSTS AS A FUNCTION OF REFLECTOR DIAMETER AND CONTOUR ACCURACY - CURRENT CONFIGURATION
- IDENTIFY AND QUANTIFY THE CRITICAL TECHNOLOGIES REQUIRED TO DEVELOPE THE REFLECTOR ABOVE
- DETERMINE PACKAGING EFFICIENCY AND WEIGHT AS A FUNCTION OF REFLECTOR DIAMETER - CURRENT CONFIGURATION
- NEW CONCEPTUAL DESIGNS TO IMPROVE PACKAGING EFFICIENCY FOR REFLECTORS UP TO 100 FT. DIA.
- CHOOSE PREFERRED CONCEPT AND PROVIDE ROM COST ESTIMATES, PACKAGING EFFICIENCY, WEIGHT AND CRITICAL TECHNOLOGIES
- PERFORM THE ABOVE TASKS FOR OFFSET FED REFLECTORS IN ADDITION TO FOCAL FED REFLECTORS

STOWED ENVELOPE PROPORTIONS

The critical parameter which determines the maximum aperture which can be stowed in shuttle is the number of primary panels in the configuration. Preliminary studies provided data on the ratio of stowed diameter to deployed diameter as the number of main panels was varied from 4 to 12. 6, 12 and 18 main panel configurations were examined in more detail for the study.

REFLECTOR CONFIGURATIONS AND RATIOS OF DIAMETER TO STOWED ENVELOPE DIMENSIONS

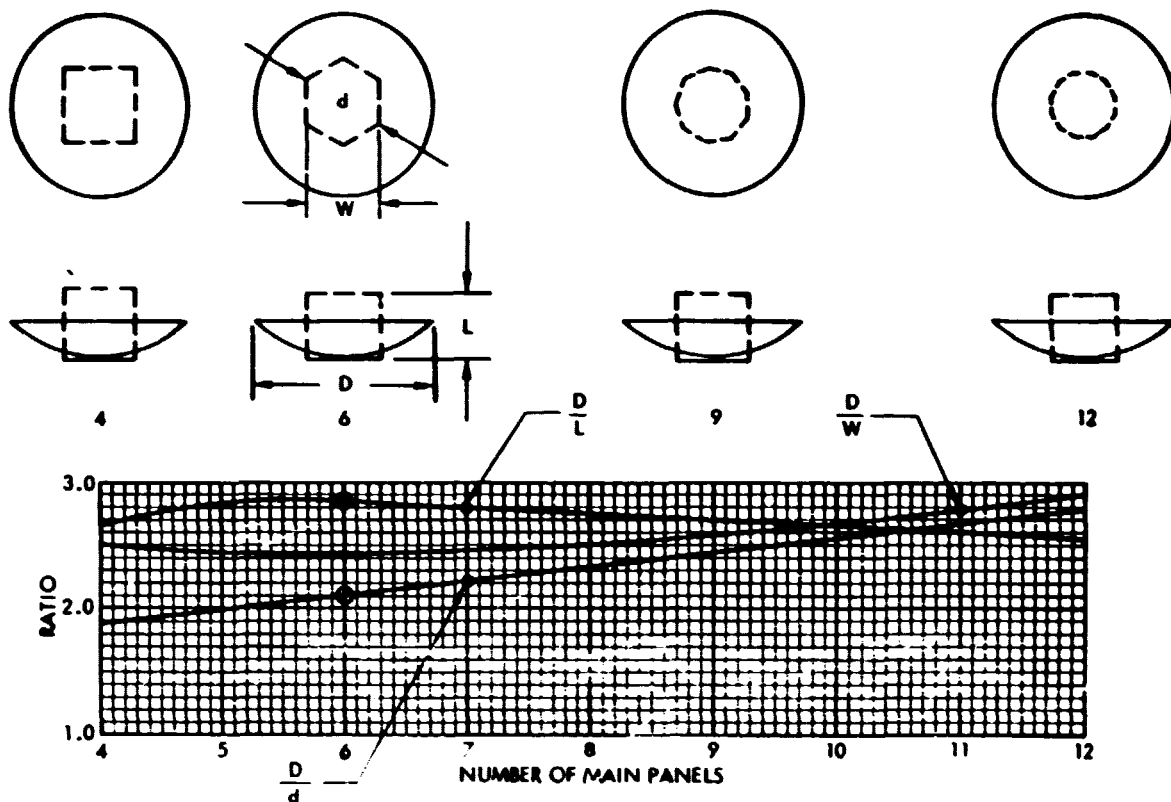

STOWAGE OPTIMIZED STUDIES

The detailed examination of the 6 main panel configuration included an optimization of the configuration to allow a more efficient packing of the panels. This included trimline adjustment to avoid interference between panels when stowed. The optimization studies were accomplished for a F/D ratio of 0.4.

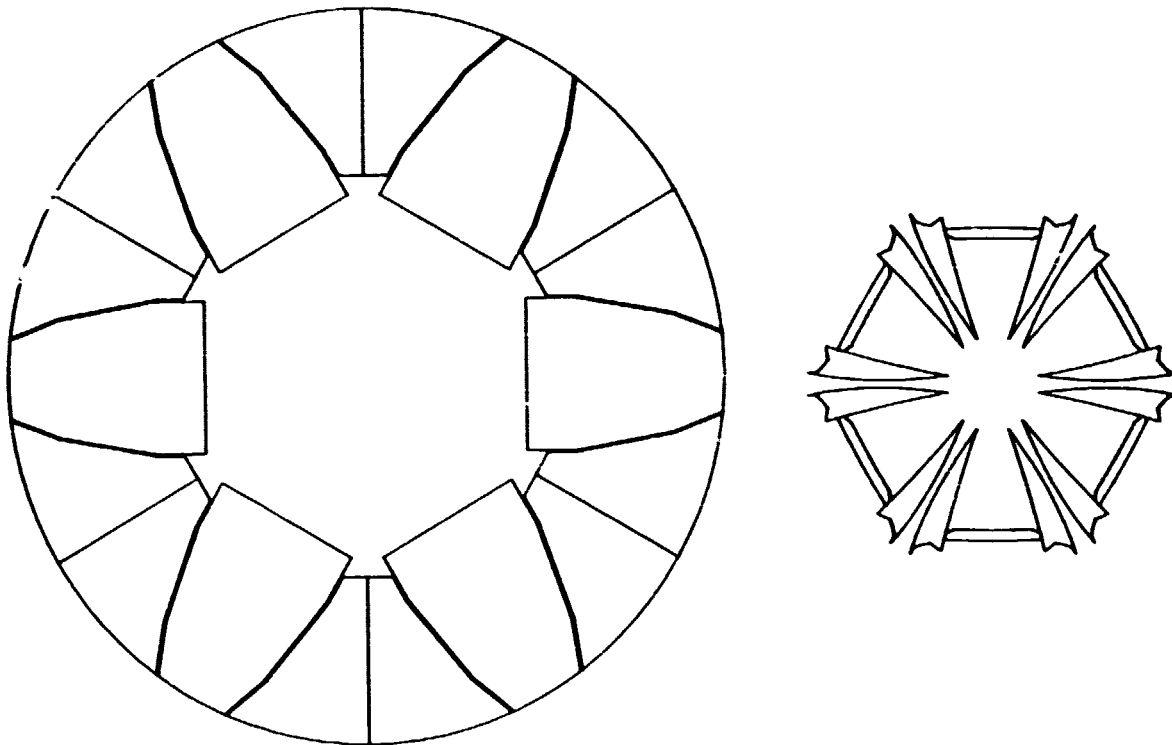

6 MAIN PANEL CONFIGURATION BEFORE OPTIMIZATION

OPTIMIZED 6 PANEL CONFIGURATION

This view is an optimized 6 panel configuration which compares with the original configuration shown previously. Note the increased aperture to stowed diameter ratio. The maximum aperture for the 6 panel configuration is 33.2 feet.

6 PANEL CONFIGURATION

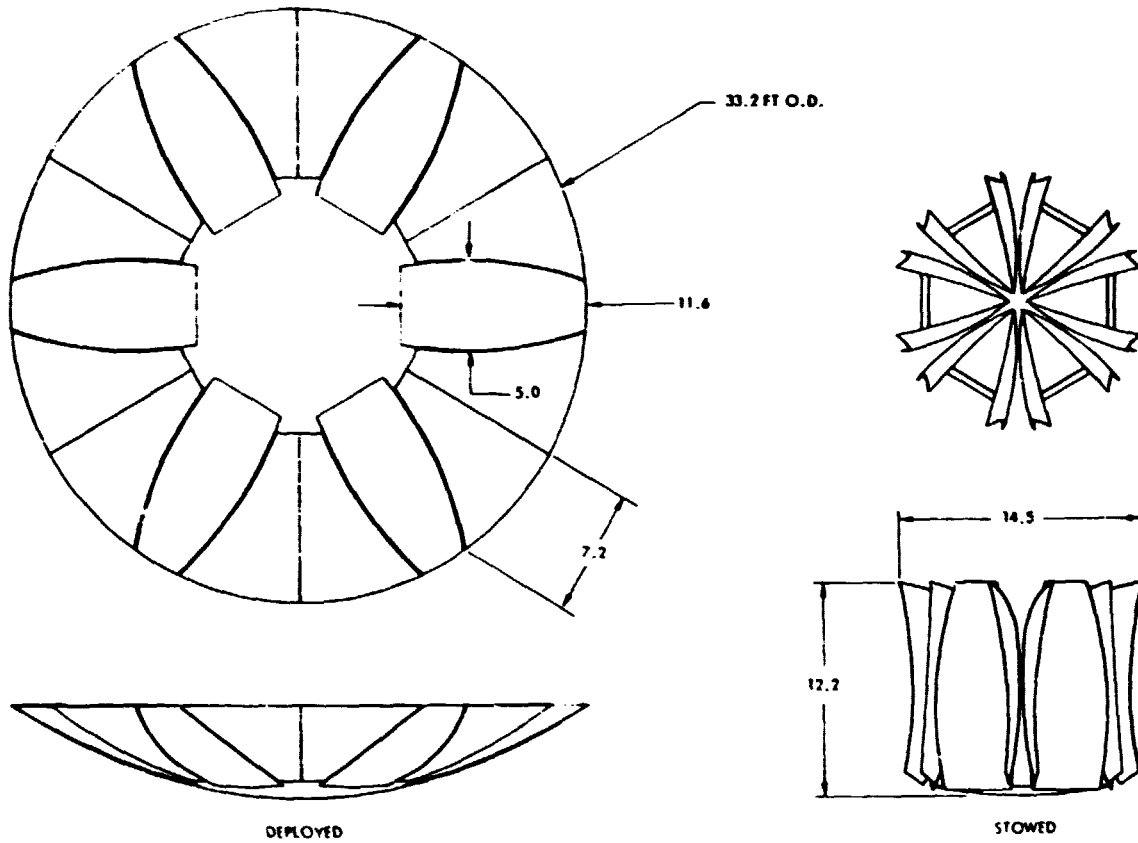

OPTIMIZED 12 PANEL CONFIGURATION

The 12 main panel configuration is illustrated below after optimization. A 37.8-foot aperture may be stowed in the shuttle with a 14.5-foot diameter stowed envelope. Note the long narrow panel envelopes when compared to the 6 panel configuration.

12 MAIN PANEL CONFIGURATION

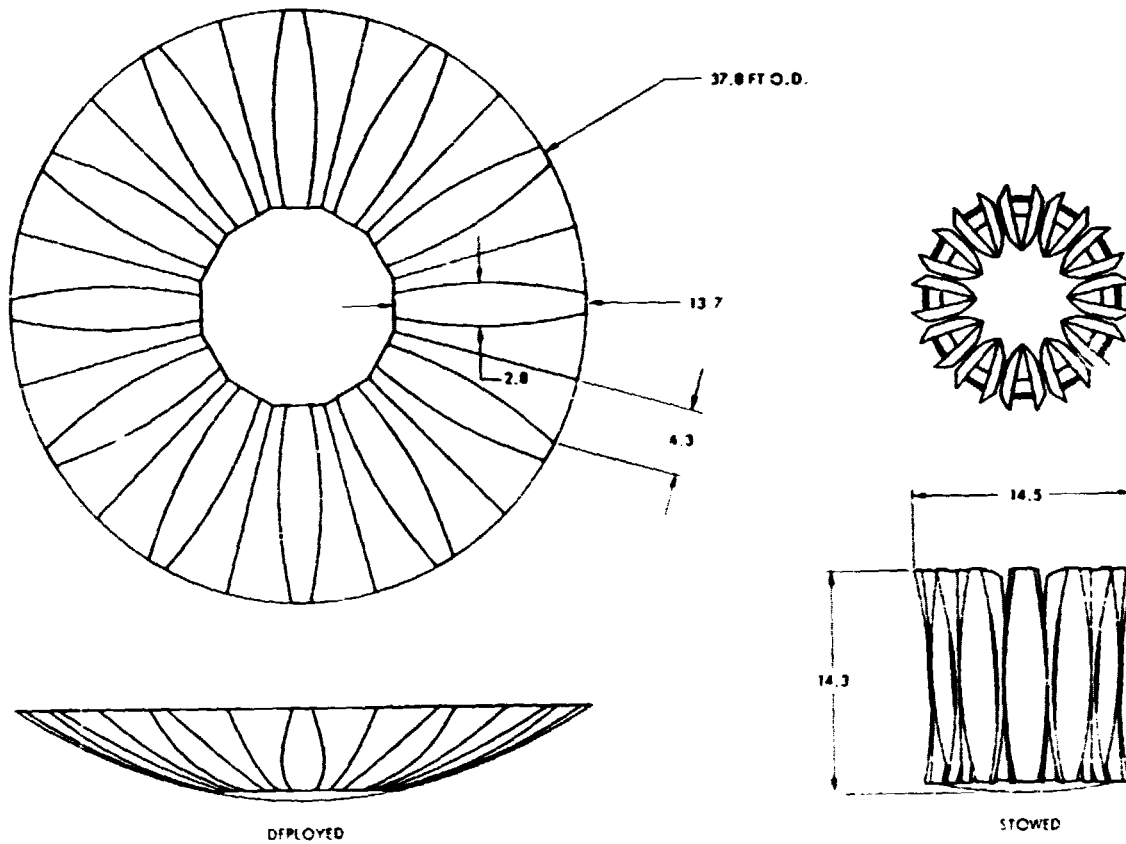

OPTIMIZATION APPROACH

This view illustrates the optimization approach. The goal is to compactly place the triangular panel and half the main panel within the allocated triangular wedge. This was accomplished most conveniently using a CAD graphical display. The influence of displacing various hinge locations was determined individually. Thence, by iteratively adjusting the hinge positions, the most compact arrangement was determined which defined the optimum geometry. A second constraint on the optimization was to minimize the radial envelope of the folded panels.

The cross-hatched areas on the panels were provided to improve the visibility of the projected surfaces.

OPTIMIZATION APPROACH, 12 PANELS

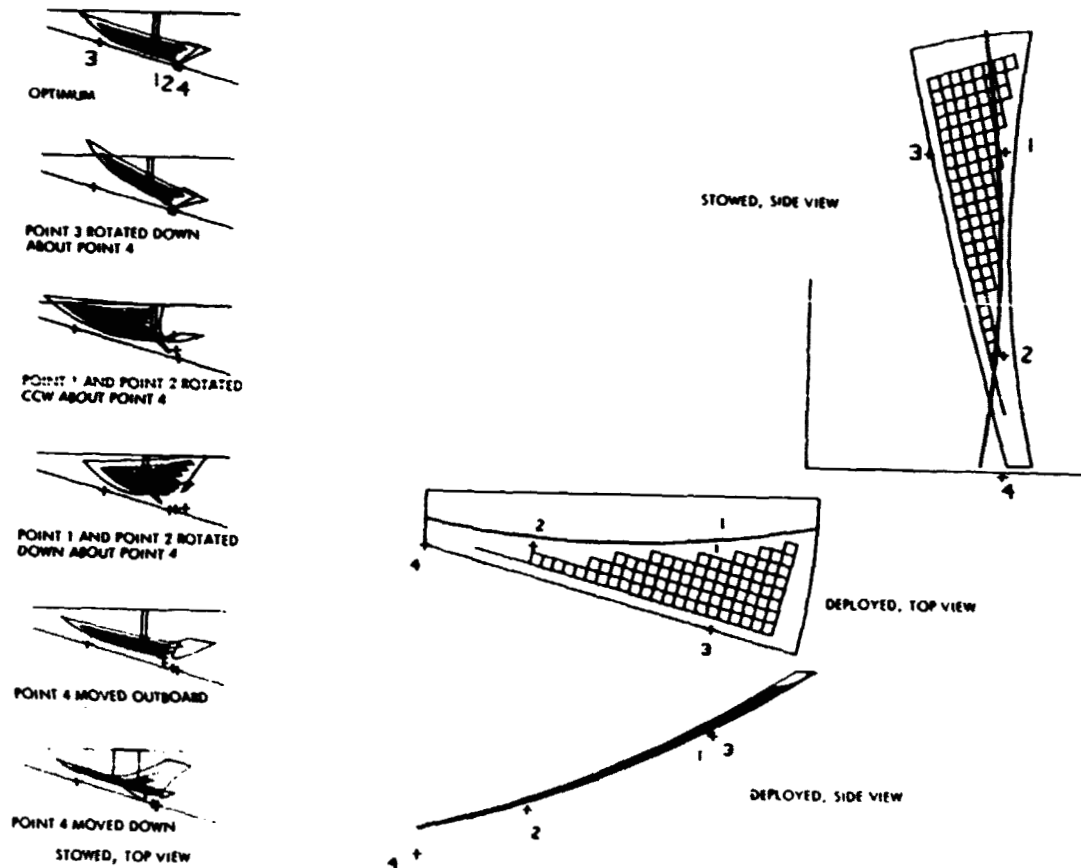

18 PANEL CONFIGURATION

The maximum stowable aperture was attained with the 18 main panel configuration. This provided a 42-foot aperture for the available 14.5-foot stowed envelope. It was determined that more than 18 main panels would not improve the stowing ratio.

18 MAIN PANEL CONFIGURATION

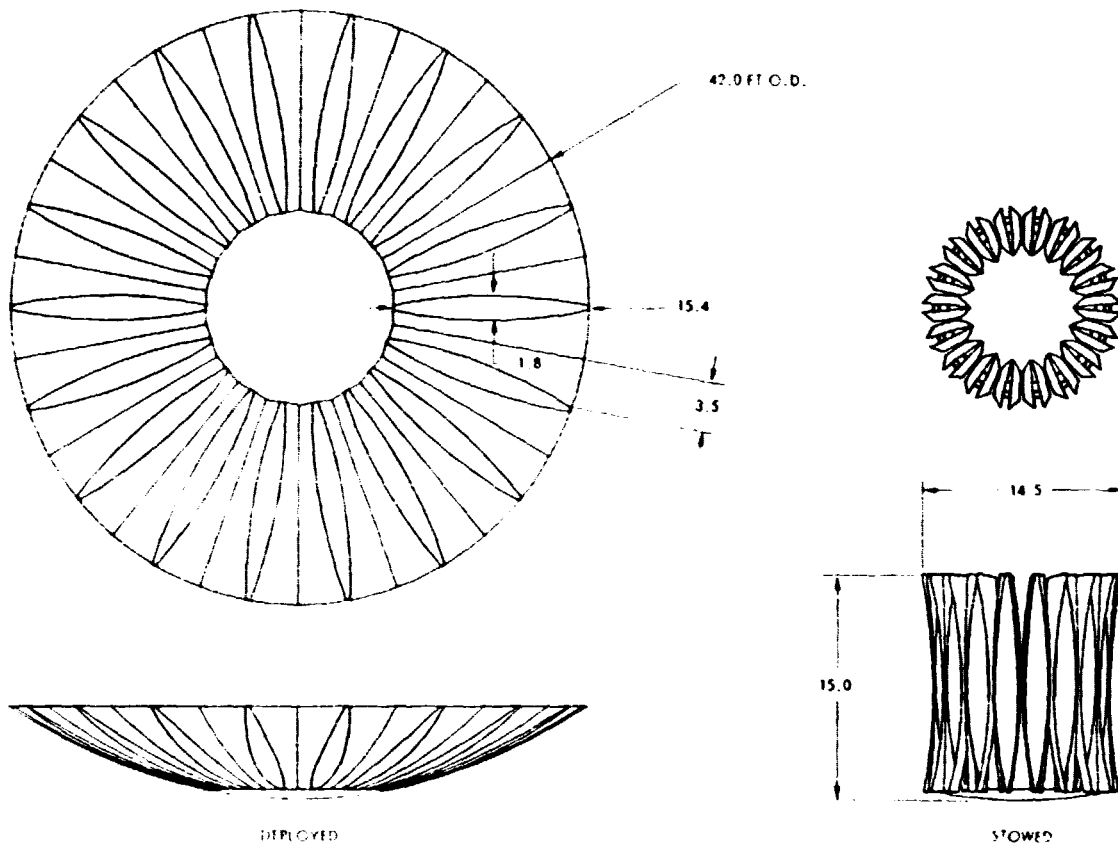

SHUTTLE STOWAGE OF 18 PANEL CONFIGURATION

Stowage of the 42-foot, 18 main panel aperture requires a 15-foot segment of the shuttle bay.

An increase of the F/D ratio from 0.4 to 0.62 for the 18 panel configuration would allow an increase in the aperture from 42 foot to 50 foot for stowage in shuttle. However, a similar F/D increase would not result in significant improvement for the 6 panel configuration, since the panel width is the governing factor rather than the curvature.

18 MAIN PANELS

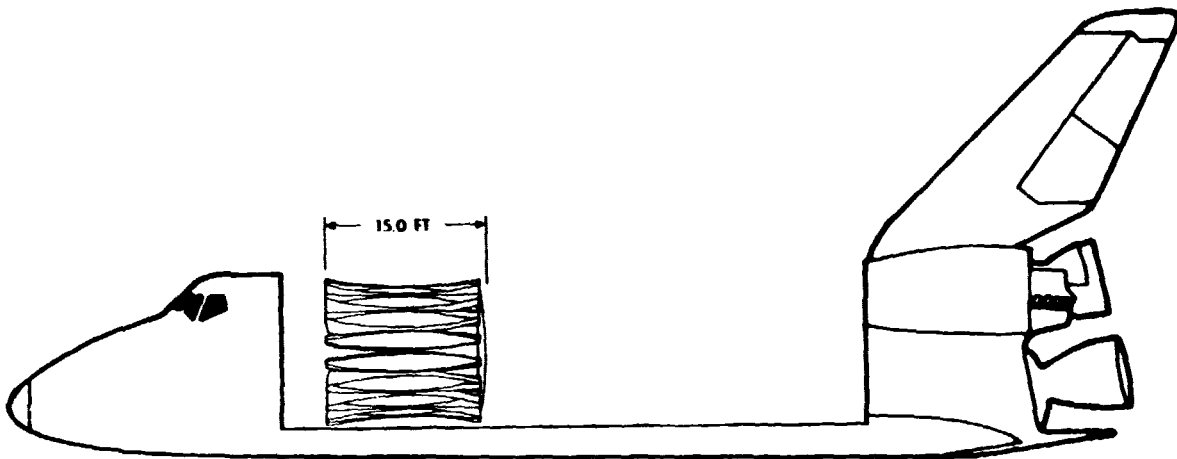

STOWED VIEW OF 18 PANEL CONFIGURATION

This enlarged view of the stowed 18 main panel configuration illustrates the detail which is possible for conceptualizing the complex geometry on the CAD (Computer Aided Design) graphical display. The long narrow envelope of the panels increases the difficulty of achieving a precision contour. Two hinge connections are provided along adjacent edges between panels. Adequate space is available within the folded reflector to provide supporting structure for a feed or subreflector.

18 MAIN PANEL CONFIGURATION, STOWED

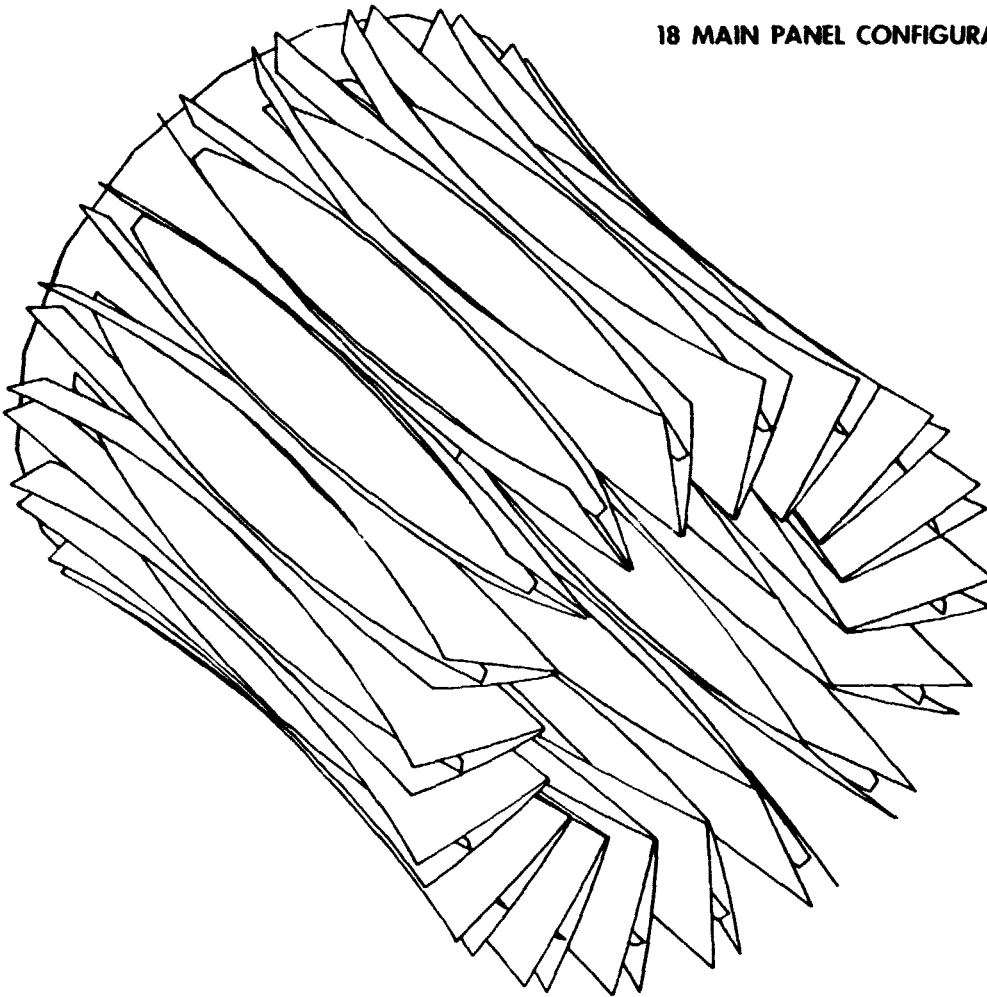

ANTENNA WEIGHT VS. DIAMETER

The weight of antenna reflectors has been estimated for diameters of 16 to 100 feet. The weight of feeds and subreflectors is not included. Since the weight of the reflector predominates, the plot is approximately valid for advanced configurations to be described which may require additional hinges or other hardware. Specific designs were assumed for 16, 24 and 100-foot apertures and intermediate points linearly interpolated. The basic construction assumed a graphite/epoxy aluminum honeycomb sandwich configuration.

ANTENNA REFLECTOR WEIGHT ESTIMATE VS. DIAMETER

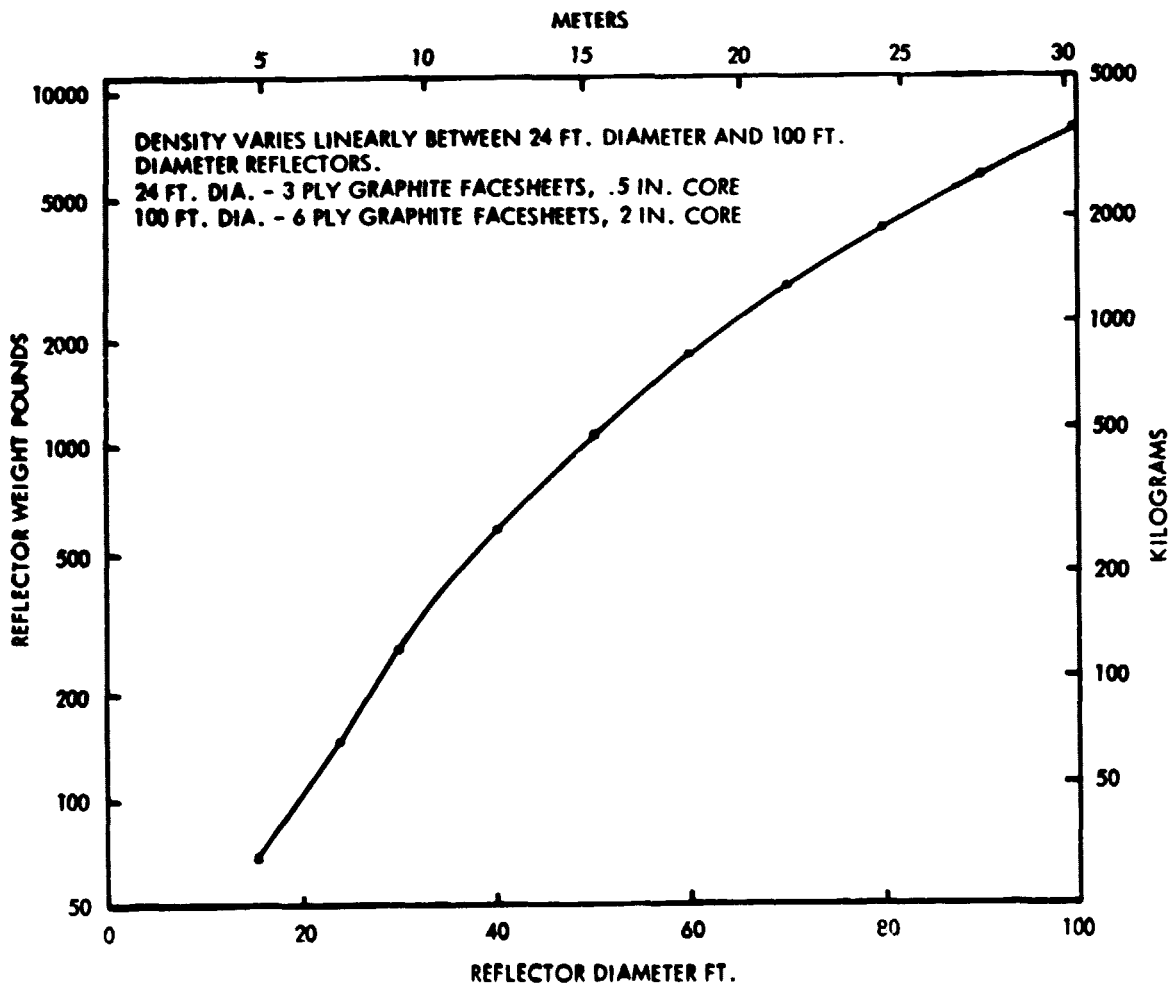

CONTOUR ERROR ESTIMATES

An attempt has been made to estimate the surface quality obtainable for the large aperture antenna reflectors of both the original and advanced designs. Four separate estimates have been made. The first three are based on presently available fabrication technology, improved fabrication technology and post fabrication adjustment of the panels, respectively. The fourth estimate is for a system with an orbit active control of panel contour.

The errors quoted are conservative. They are based on considerations of the long narrow panel shapes and on thermal distortion analyses for a 16-foot aperture.

CONTOUR ERROR ESTIMATES

	<u>RMS DEVIATION</u>	<u>MAX DEVIATION</u>	<u>BASIS OF ESTIMATE/ASSUMPTION</u>
<u>AS FABRICATED</u>			<u>FROM FAB OF SOLID REFLECTORS AND TEST PANELS</u>
CENTER SECTION	$0.9 \times 10^{-4} D$	$2.7 \times 10^{-4} D$	
OUTER PANELS	$2.0 \times 10^{-4} L$	$6.0 \times 10^{-4} L$	
<u>POST FAB ADJUSTED</u>	.0005"	.0015"	TOLERANCE IN SETUP AND INSTRUMENTATION ASSUMED SAME REGARDLESS OF SIZE MAX PANEL LENGTH 19 FT.
<u>ASSEMBLY</u>	.001"/10' DIA	.003"/10' DIA	ESTIMATE ONLY, ERROR IN LOCATING PANEL IN OPTIMUM POSITION AND ATTACHING HINGES
<u>DEPLOYMENT</u>	.0005"/20' DIA	.0015"/20' DIA	BASED ON REPEATABILITY OF SUNFLOWER
<u>THERMAL</u>	.002"/20' DIA .0034"/100' DIA	.006"/20' DIA .0102"/100' DIA	BASED ON THERMAL DISTORTION ANALYSIS OF 16 FT. REFLECTOR AND MAX DEVIATION = .006 CALCULATED FOR INDIVIDUAL PANELS OF 40' DIA.

NET RMS ERROR ESTIMATE

The total RMS performance of various sized apertures for the basic configuration, as well as advanced configurations, is shown here. This performance is predicated upon the utilization of a post fabrication panel shape adjustment to optimize the contour. This technique is commonly applied and is considered state-of-the-art.

ESTIMATE OF RMS ERROR POST FAB PANEL ADJUSTMENT

ERROR CONTRIBUTOR	1 RING			2 RINGS			3 RINGS		
	20'	30'	40'	40'	60'	80'	80'	100'	120'
POST FAB ADJUSTMENT	.0005	.0005	.0005	.0005	.0005	.0005	.0005	.0005	.0005
ASSEMBLY	.0010	.0020	.0030	.0040	.0050	.0060	.0070	.0080	.0090
DEPLOYMENT	.0005	.0008	.001	.0015	.0020	.0030	.0035	.0040	.0045
THERMAL	.0020	.0022	.0024	.0024	.0027	.0030	.0030	.0034	.0037
TOTAL	.0040	.0055	.0069	.0084	.0102	.0125	.0140	.0159	.0177

RIGID REFLECTOR PERFORMANCE EXTRAPOLATION

An independent error assessment was accomplished based on extrapolation of existing data for solid contour reflectors. This was performed for a 30-foot aperture, 6 panel configuration. The results are consistent with the previous chart. It is suggested that this performance may be considerably improved by using precision tooling and on-orbit figure control.

EXPECTED MECHANICAL PERFORMANCE (30 FT APERTURE)

	DEMONSTRATED CAPABILITY	PROJECTED CAPABILITY
MANF RMS	0.002 ⁽¹⁾	0.001 ⁽²⁾
ASSY RMS	0.002	0.001 ⁽³⁾
ORBIT RMS	0.002	0.001 ⁽⁴⁾
R.S.S.	0.004	0.002

- (1) POST-FABR ADJUSTMENT OF PANEL CONTOURS
- (2) PRECISION LAYUP MOLD
- (3) IMPROVED ASSEMBLY TOOLING
- (4) IN-ORBIT FIGURE CONTROL

SHAPE CONTROL ACTUATION SYSTEM

On-orbit shape control for minimizing the effect of orbital environments on contour RMS could be readily implemented on the Advanced Sunflower configuration. Actuators for applying linear and angular differential motions between reflector panels can readily be integrated into the design at the hinge assemblies, as illustrated. These would be selectively actuated by a feedback control loop connected to a system of contour distortion sensors.

SHAPE CONTROL ACTUATION SYSTEM FOR LARGE PRECISION DEPLOYABLE REFLECTORS

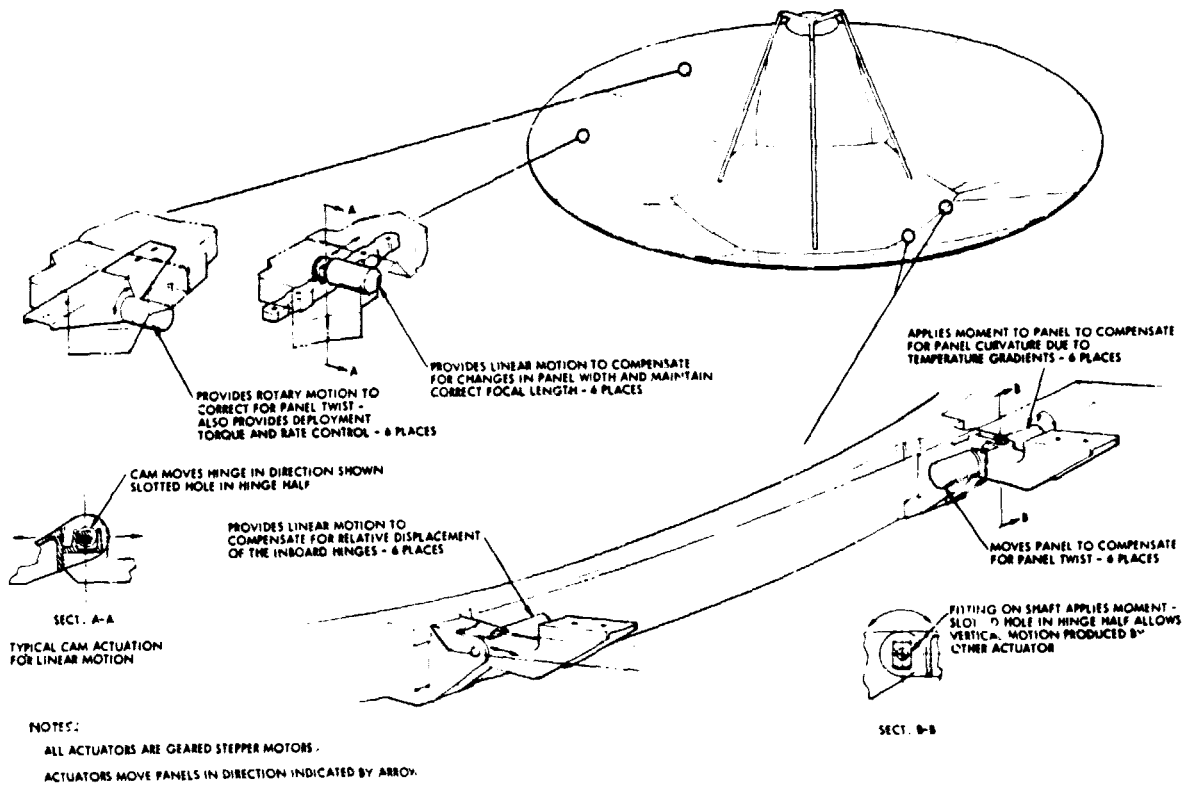

ALTERNATIVE DESIGNS

Several designs have been considered as possible alternatives to improve the stowed to deployed diameter ratio, and thereby increase the size of the antenna stowable in the shuttle. Of the six designs examined, one, the Sunflower concept, is an existing and successful design, one is a modification of the original design, and the other four involve the addition of a second a possibly a third ring of panels to the original configuration.

The Sunflower concept has been used successfully and is capable of providing a 100-foot antenna stowable in the shuttle. The major drawback, however, is that upon deployment the panels are not connected together and would require either complicated latching mechanisms or considerable EVA to achieve a sufficiently accurate reflector.

100 FT. DIA. "SUNFLOWER" REFLECTOR

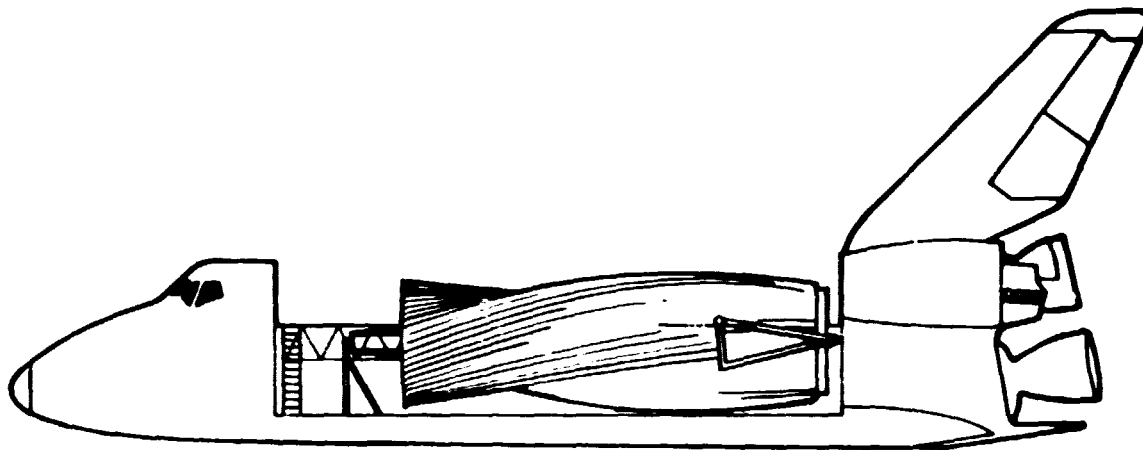

DOUBLE RING CONFIGURATION

The most successful approach so far discovered to improve packing has been to break the antenna into two rings of panels rather than one. By this method, the effect of the panel curvature is reduced and the panels may be folded closer to the axis of the reflector. Several ways of attaching and controlling this second ring have been examined. Some of the concepts have the potential of being extended to a three-ring configuration, perhaps using different concepts for each ring.

The simplest method to build a second ring is simply to split a single ring into two with corresponding panels. The hinges of the single ring are repeated in each new ring. The main panels of the outer ring are hinged to the outboard end of the main panels of the inner ring, while the triangular panels of the two rings are not connected. By utilizing this new degree of freedom, and by manipulation of the outer ring hinges, the second ring can be optimized independently, taking advantage of the reduced curvature of the shorter panels.

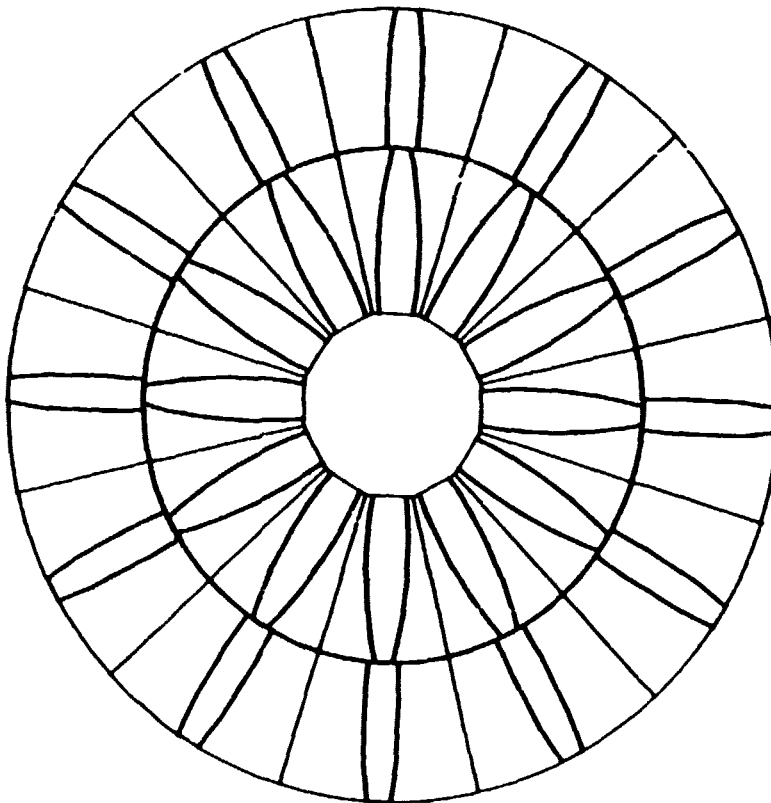

DEPLOYED, TOP VIEW

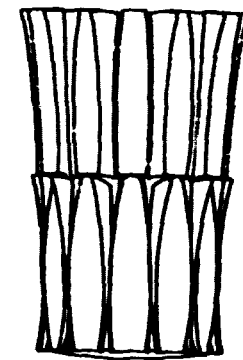

STOWED, SIDE VIEW

12 MAIN PANELS IN BOTH RINGS

HALF PANEL INNER RING

To reduce the number of panels required for the system described above, the inner ring may be composed of half as many panels as the outer, taking advantage of the empty space inside the lower part of the stowed antenna. Since alternate outer ring main panels are then unsupported, additional mechanisms must be added to completely control deployment.

6-12 MAIN PANEL DOUBLE RING CONFIGURATION

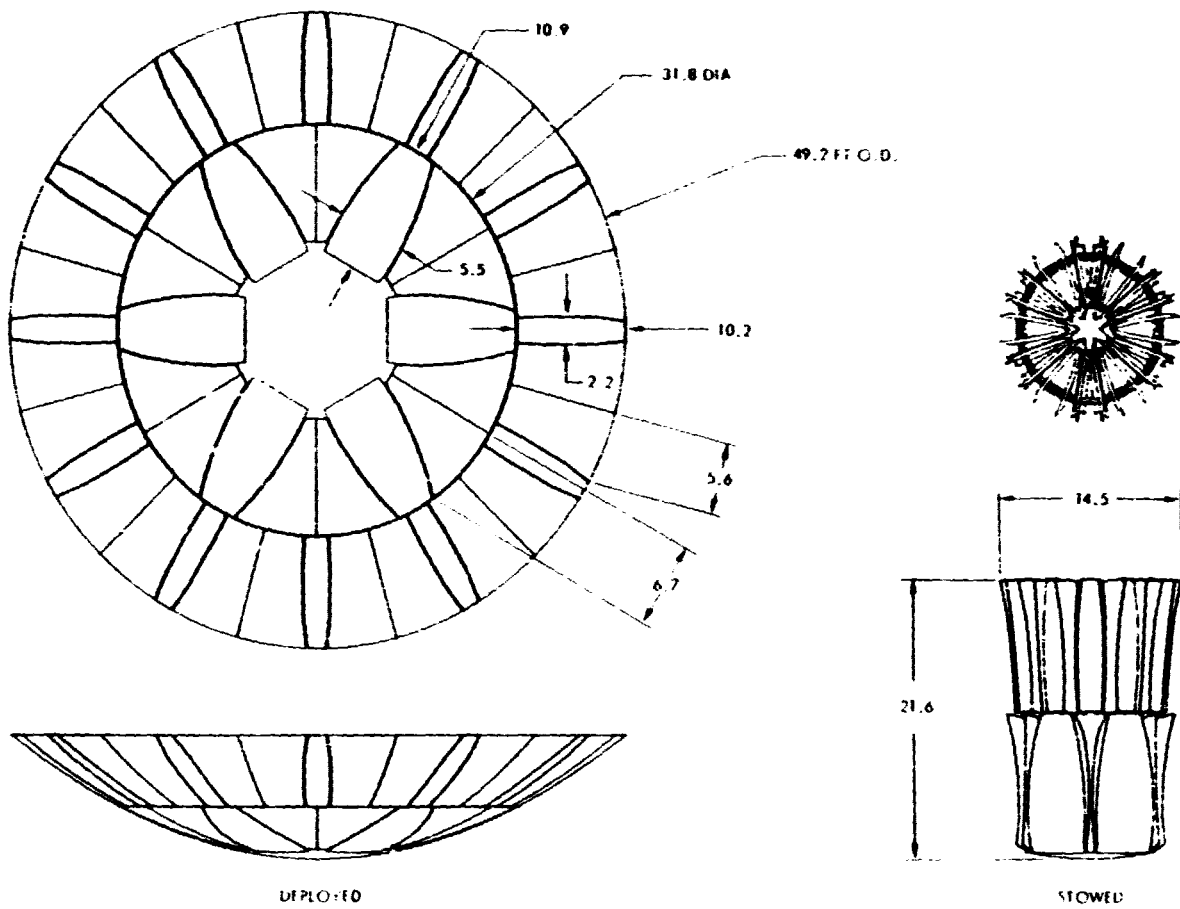

OUTER RING SUPPORT CONCEPT

To substitute for the inner ring panels, control arms may be substituted. These arms are connected to the support ring and are driven by the same drive shaft as for the original panels. This configuration has a six panel inner ring and a twelve panel outer ring. A major drawback of this configuration is that the arms are not connected to the inner ring of panels as are the main panels, which results in a less stiff reflector. The control arms may also add significant weight and complexity to the structure.

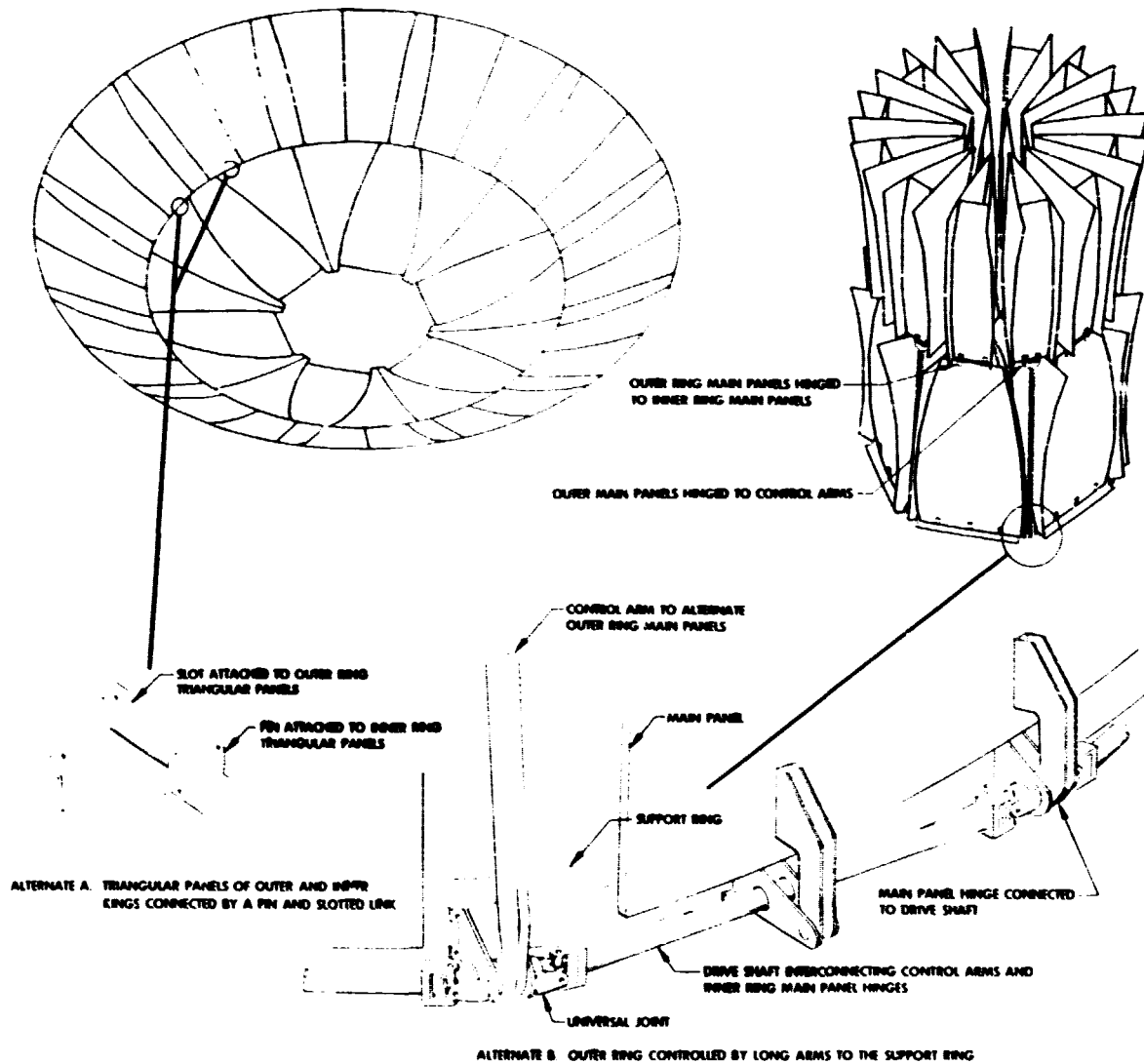

DOUBLE RING CONFIGURATION, 6-12 MAIN PANELS SHOWN

18-36 DOUBLE RING CONFIGURATION

Application of the double ring concept to the 18 panel configuration almost doubles the aperture which can be stowed in shuttle. In the 18-36 concept, the maximum aperture is 80 foot with a F/D of 0.4. The stowed length occupies over half the available shuttle bay capacity.

18-36 MAIN PANEL DOUBLE RING CONFIGURATION

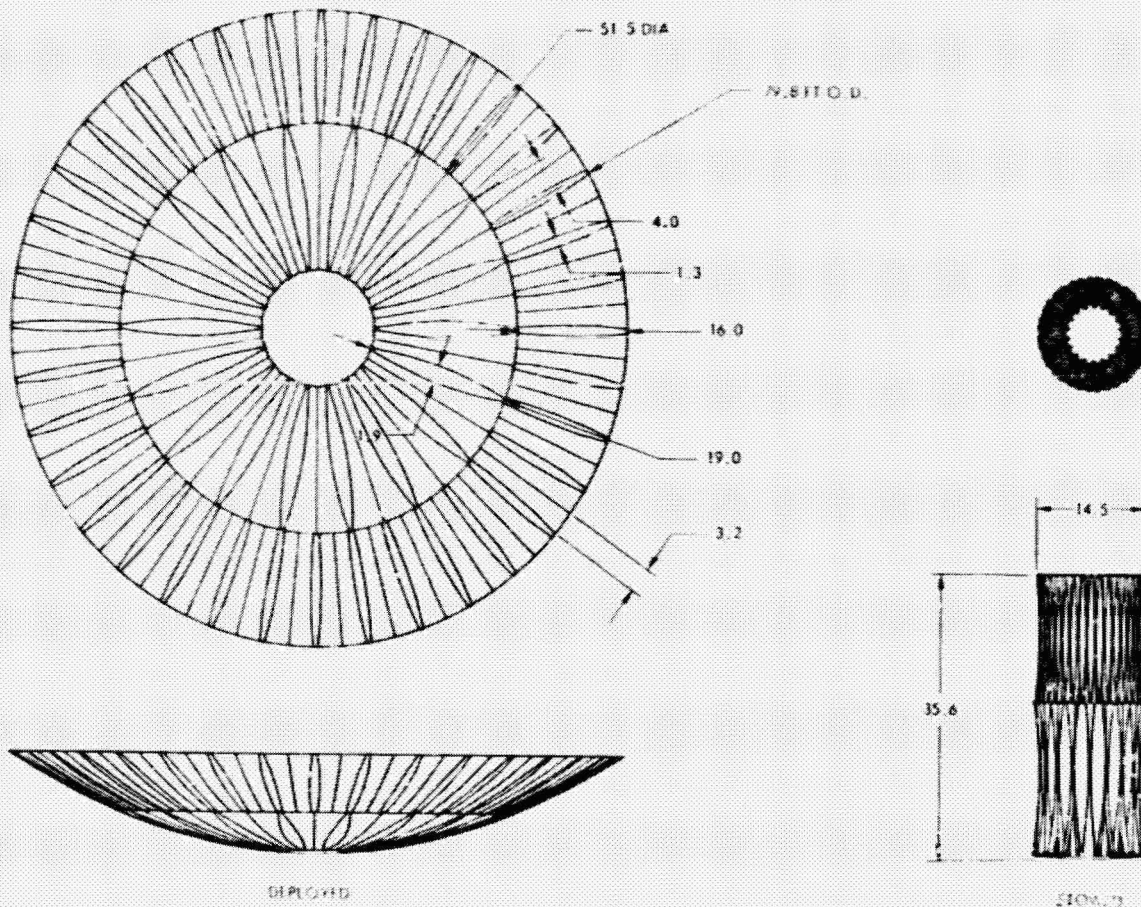

80-FOOT APERTURE ON SHUTTLE

This view illustrates the deployed 18-36 panel configuration, 80-foot aperture supported from within the shuttle bay.

A detailed study of offset reflectors was not performed due to time limitations and the relative priority of other tasks. Preliminary investigation, however, indicates that offset reflectors would stow more compactly than axisymmetric configurations of the same diameter due to the reduced panel curvature. Manufacture would be more difficult due to the loss of symmetry.

80-FT. (24.4-METER) PRECISION DEPLOYABLE REFLECTOR ON SHUTTLE

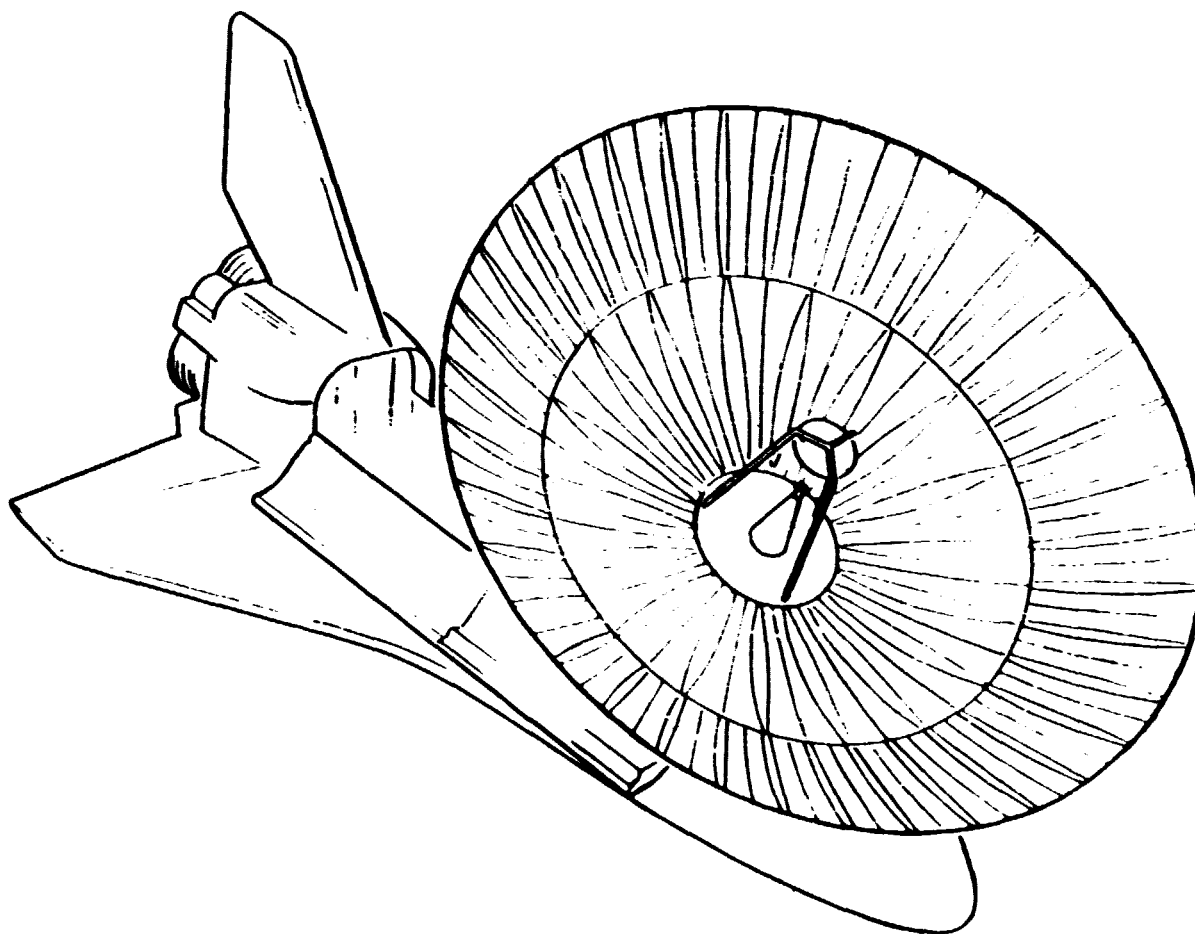

CRITICAL TECHNOLOGY STUDIES

Several critical new technologies judged necessary for the construction of successful large diameter antennas have been identified. These technologies mainly concern the advanced fabrication and adjustment techniques, and related problems. In addition, they apply equally to both the original design and the advanced concepts.

The first study proposed is to investigate designs and processes which reduce the as-fabricated reflector panel errors. The principal parameters in this study are the materials and tooling. Improved tooling precision and room temperature curing should contribute greatly to improved panel contours.

CRITICAL TECHNOLOGY STUDIES

TITLE: CONTOUR ACCURACY CONTROL FOR PRECISION DEPLOYABLE REFLECTORS.

STUDY 1

OBJECTIVE: IMPROVE ACCURACY OF FABRICATING INDIVIDUAL PANELS.

APPROACH: DESIGN, FABRICATE AND MEASURE PANELS TO DEMONSTRATE THE ADVANTAGE OF ONE CONFIGURATION OVER ANOTHER. ANALYTICAL MODELING WILL BE UTILIZED WHERE FEASIBLE TO PREDICT THE EFFECT OF THE VARIOUS PARAMETERS.

TASKS:

- IDENTIFY PARAMETERS THAT COULD CONTRIBUTE TO DISTORTION
- MODEL PANEL AND VARY PARAMETERS TO ASCERTAIN CONTRIBUTION OF EACH
- DESIGN TEST PANELS TO ISOLATE EACH PARAMETER TO DETERMINE ITS CONTRIBUTION
- FABRICATE BOTH FLAT AND CURVED PANELS TO ISOLATE THE PARAMETERS AND PROVIDE CONTROL AND REPEATABILITY OF THE FABRICATION PROCESSES
- MEASURE CONTOUR ACCURACY
- OPTIMIZE THE CONFIGURATION

POST FABRICATION ADJUSTMENT

The second technology study would develop concepts for post fabrication adjustment as an approach to developing high precision contours. This approach has been very successful for rigid contour reflectors. The problems peculiar to this configuration are the high aspect ratio panels.

CRITICAL TECHNOLOGY STUDIES

STUDY II

- TITLE:** CONTOUR ACCURACY IMPROVEMENT BY POST-FABRICATION ADJUSTMENT OF PRECISION DEPLOYABLE REFLECTORS.
- OBJECTIVE:** DEVELOP CONCEPT FOR IMPROVING ACCURACY OF INDIVIDUAL PANELS BY POST FABRICATION ADJUSTMENT.
- APPROACH:** ONE OR MORE CONFIGURATIONS WILL BE CHOSEN FROM TRADE-OFF STUDIES OF VARIOUS CONCEPTS. THE ACCURACY OF THE CONCEPTS WILL BE DEMONSTRATED BY DESIGNING, FABRICATING AND MEASURING THE CONTOUR OF PANELS REPRESENTATIVE OF A DESIRED LARGE DIAMETER REFLECTOR.
- TASKS:**
- CONCEPTUAL DESIGN OF ALTERNATE CONFIGURATIONS
 - USE ANALYTICAL MODEL TO DETERMINE OPTIMUM NUMBER AND LOCATION OF ADJUSTMENT POINTS
 - CHOOSE PRIME CONFIGURATION AND DESIGN SHELL, AND BACK-UP STRUCTURE
 - FABRICATE SHELL ON EXISTING MOLD OF 98 IN. FOCAL LENGTH IF DEEMED ADEQUATE
 - FABRICATE BACK-UP STRUCTURE
 - MEASURE CONTOUR
 - ADJUST TO OPTIMIZE CONTOUR

ACTIVE CONTOUR ADJUSTMENT TECHNOLOGY

The third critical technology study identified is the development of active contour control techniques for large aperture reflectors. The development of actuation systems, including actuator mechanisms, and their integration into the deployment mechanisms, requires investigation. This would include analytical optimization studies, design and verification tests of breadboard hardware.

CRITICAL TECHNOLOGY STUDIES

STUDY III

- TITLE:** A STUDY OF ACTIVE CONTOUR CONTROL OF LARGE PRECISION DEPLOYABLE REFLECTORS.
- OBJECTIVE:** DEVELOP CONCEPT FOR IMPROVING ACCURACY OF COMPLETE REFLECTOR IN SPACE WITH ACTIVE ADJUSTMENT.
- APPROACH:** AN ANALYTICAL MODEL WILL BE USED TO PERFORM THE TRADE-OFFS OF THE CONCEPTUAL DESIGNS. AFTER THE ADJUSTMENT LOCATIONS AND THE REQUIRED FORCE/MOTION IS DETERMINED THE ACTUATING SYSTEM WILL BE DESIGNED. ONE OR MORE TYPICAL JOINTS WILL BE DESIGNED, FABRICATED AND TESTED TO VERIFY ITS CAPABILITY. A BREADBOARD OF THE SENSOR SYSTEM AND CONTROL ELECTRONICS WILL BE DESIGNED AND BUILT TO DEMONSTRATE THE COMPLETE SYSTEM ON A REPRESENTATIVE PANEL.

SUMMARY

In summary, our study has demonstrated the feasibility of the basic concept for shuttle applications with 40-foot apertures at frequencies of 100 GHz. We have also identified concepts allowing extension of the basic concept to 80-foot apertures, operable at 60 GHz.

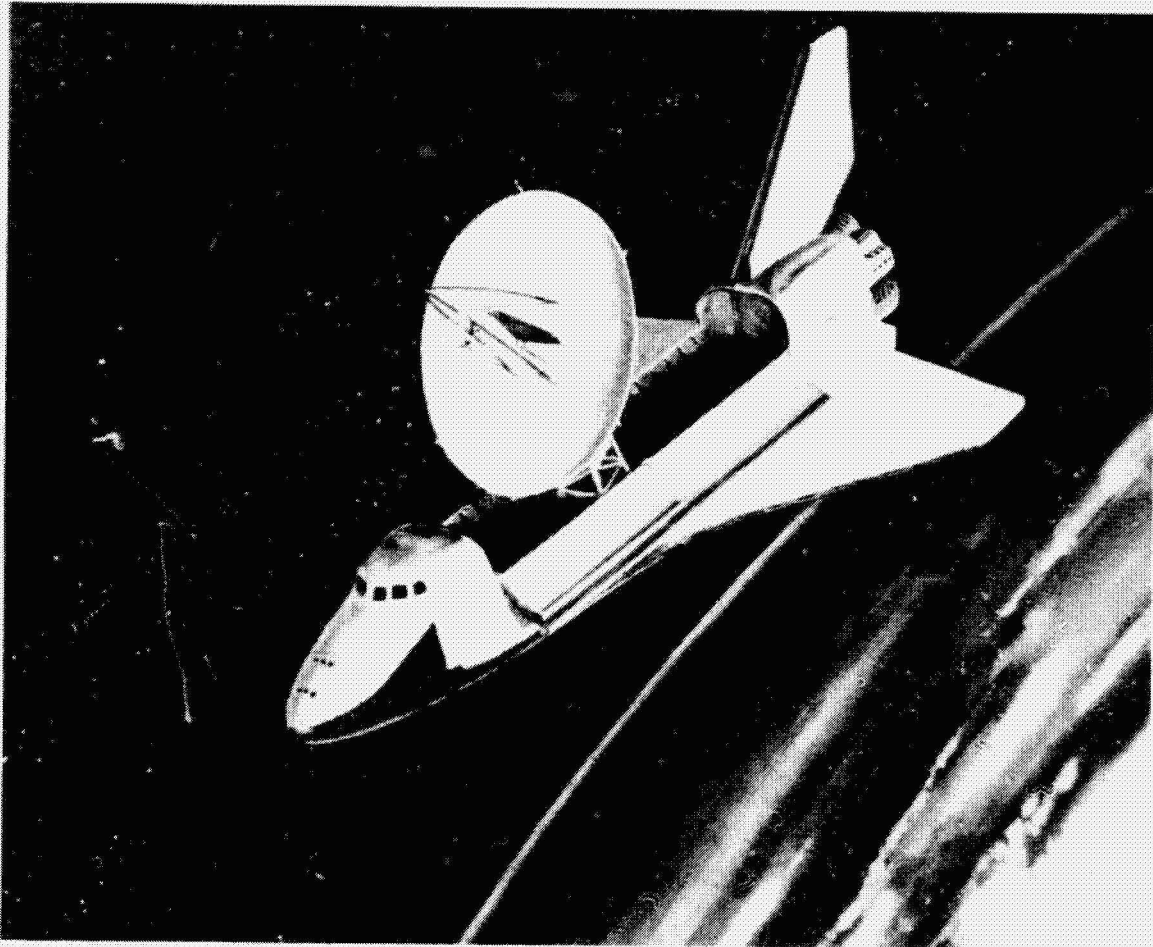

ORIGINAL PAGE IS
OF POOR QUALITY