



NASA TM-80232

# NASA Technical Memorandum 80232

NASA-TM-80232 19800011749

## OPERATIONAL IMPLICATIONS OF SOME NACA/NASA ROTARY WING INDUCED VELOCITY STUDIES

HARRY H. HEYSON

FOR REFERENCE

NOT TO BE TAKEN FROM THIS ROOM

FEBRUARY 1980

**NASA**

National Aeronautics and  
Space Administration

**Langley Research Center**  
Hampton, Virginia 23665

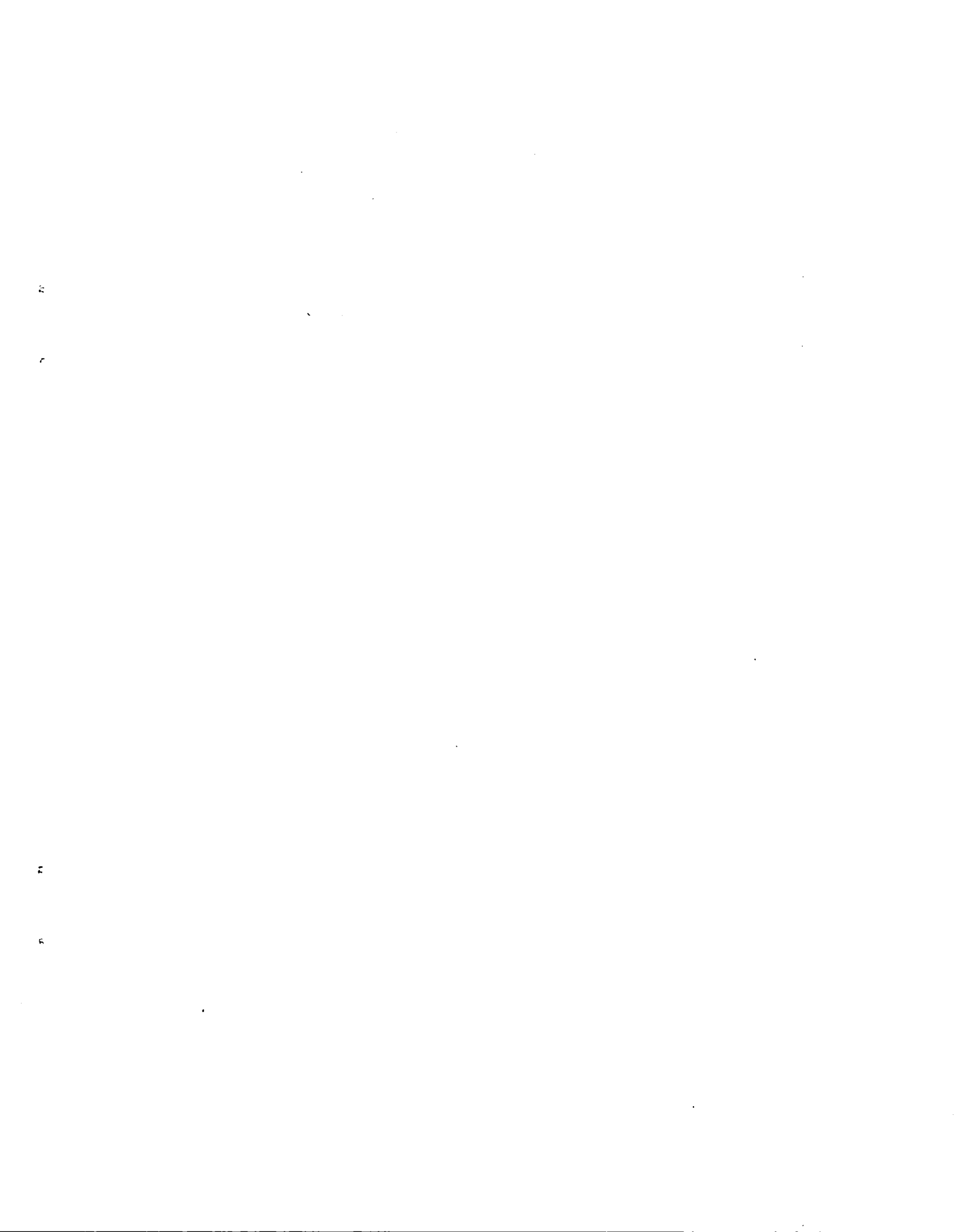

OPERATIONAL IMPLICATIONS OF SOME NACA/NASA ROTARY WING  
INDUCED VELOCITY STUDIES

by Harry H. Heyson  
Langley Research Center  
Hampton, Virginia 23665

SUMMARY

Over the last twenty-five years, NACA and NASA have conducted numerous studies of the induced velocities near a lifting rotor. The results have been presented in papers aimed at design and research engineers rather than operators; as a result, the operational consequences of these studies are not widely known among helicopter operators. The present paper reviews a number of these fundamental studies and attempts to draw out the operational implications and restrictions of these studies in a form specifically aimed at the user.

Wind-tunnel measurements show that the wake of a rotor, except at near-hovering speeds, is not like that of a propeller. The wake is more like that of a wing except that, because of the slow speeds, the wake velocities may be much greater. The helicopter can produce a wake hazard to following light aircraft that is disproportionately great compared to an equivalent fixed-wing aircraft. This hazard should be recognized by both pilots and airport controllers when operating in congested areas.

Even simple momentum theory shows that, in autorotation and partial-power descent, the required power is a complex function of both airspeed and descent angle. The power required may increase violently, rather than decrease, with rate of descent. The nonlinear characteristic, together with an almost total lack of usable instrumentation at low airspeeds, has led to numerous "power-settling" accidents. Simple rules can avoid the regions in which these accidents occur.

The same theory shows that there is a minimum forward speed at which a rotor can autorotate. Neglect of, or inadequate appraisal of, this minimum speed has led to numerous accidents.

Ground effect is generally counted as a blessing since it allows overloaded takeoffs; however, it also introduces additional operation problems. These problems include premature blade stall in hover, settling in forward transition, shuddering in approach to touchdown, and complications with yaw control. Some of these problems have been treated analytically in an approximate manner and reasonable experiment agreement has been obtained. An awareness of these effects can prepare the user for their appearance and their consequences.

N80-20231 #

## INTRODUCTION

The early years of helicopter development concentrated on efforts to get into the air and fly. Theoretical treatments (such as ref. 1) were largely based on earlier work aimed at the autogyros of the 1920's. The self-generated interference field of the rotor was treated in a "lump-sum" manner by simple analogies to airplanes. These elementary treatments were adequate for a time in which helicopters were lightly-loaded curiosities busily engaged in carving out a small niche where their unique hovering capabilities were of paramount importance.

Numerous problems developed in the early years which required a more detailed treatment of the flow generated by a rotor. The earliest investigators noted the problems encountered in vertical flight (refs. 1-6) and substantial efforts were made to study that flight regime by flow-field visualization and by deriving empirical rules. Ground effect was attacked by theory (ref. 7) with usable results, and flow visualization studies (ref. 8) demonstrated many unusual features of the wake. The nonlinear behavior of induced power at low speeds was examined in references 9 and 10. Finally, induced flow-field theories (refs. 10-12) aimed at explaining vibratory rotor loads and the interference between the rotor and auxiliary wings and tails began to appear.

The piecemeal state of knowledge of rotor flow fields was evident in the review paper by Gessow (ref. 13) in the 1954 NACA Conference on Helicopters; however, the same meeting also resulted in a paper (ref. 14) presenting preliminary results from the first comprehensive wind-tunnel studies of rotor flow fields. The complete presentation and analysis of these results (ref. 15) showed the significance of the radial load distribution of the rotor on the external flow. Even prior to publication, this paper led to a major expansion of theoretical studies (refs. 16-20).

Reference 21 demonstrated the utility of the theory in predicting interference between rotors and wings, tails, and other rotors; however, it also demonstrated that the timewise fluctuating field of the rotor was necessary to study the rapidly varying loads on the blades as they rotated. The startling experimental results of reference 22, in combination with the observations of reference 21, initiated a revolution in rotor theory (refs. 23-28) that continues to this day.

The papers described hereto, and subsequent NASA studies, were intended primarily for, and distributed to, engineers in the industry. They have played a major role in the development of current helicopters; however, because of the limited intent and distribution of these papers, many aspects pertaining to the operation of helicopters have not been emphasized nor have they been presented directly to the user.

The purpose of the present paper is to present some highlights of the broad NACA/NASA efforts throughout the years, with particular emphasis given to those results having special importance to the user. Subjects covered include the rotor wake and vortex hazards, partial power descent and minimum speed for autorotation. Several aspects of ground effect are covered, including nonuniform

wakes, nonlinear power and control effects in forward flight, and yaw control at near-hovering speeds.

#### SYMBOLS

|           |   |
|-----------|---|
| A         | aspect ratio, $b^2/S$   |
| b         | span  |
| $C_L$     | lift coefficient, $L/qS$  |
| $C_P$     | rotor power coefficient, $P/\pi R^2(\Omega R)^3$  |
| $\dot{E}$ | rate of gain of potential energy  |
| H         | height of rotor above ground  |
| L         | lift  |
| P         | power   |
| $P_C$     | induced power to climb  |
| $P_h$     | induced power when hovering out of ground effect  |
| $P_s$     | induced shaft power   |
| q         | local dynamic pressure  |
| $q_0$     | free-stream dynamic pressure $1/2\rho V^2$  |
| R         | rotor radius  |
| S         | wing or rotor-disk area   |
| T         | thrust  |
| V         | forward velocity  |
| $V_G$     | velocity along glideslope   |
| $V_{min}$ | minimum speed   |
| w         | local vertical induced velocity   |
| $w_0$     | average induced velocity  |
| $w_h$     | reference induced velocity, also, average induced velocity when hovering out of ground effect |
| X,Y,Z     | longitudinal, lateral, and vertical distances from the rotor hub                              |

|            |   |
|------------|---|
| $\alpha$   | rotor tip-path-plane angle of attack, positive leading edge up      |
| $\gamma$   | glide slope angle   |
| $\Delta u$ | ground-induced longitudinal interference velocity                   |
| $\Delta w$ | ground-induced vertical interference velocity                       |
| $\theta$   | rotor tip-path plane inclination with respect to the horizon        |
| $\mu$      | tip-speed ratio, $V/R$  |
| $\rho$     | mass density of air   |
| $\chi$     | wake skew-angle, angle from vertical to the center line of the wake |
| $\Omega$   | rotor rotational speed  |

#### THE ROTOR WAKE AND VORTEX HAZARD

Nature of wake.- The wake of a rotor in forward flight is very like that of a wing. Figure 1 (ref. 15) shows the flow angles measured behind a rotor in cruising flight and figure 2 shows simultaneous measurements of the dynamic pressure in the wake. The winglike character of the flow is evident. Even at the trailing edge of the rotor, the flow has already rolled up almost completely into a strong vortex pair. Locally, the flow angles exceed 30 degrees and the dynamic pressures are as much as 60 percent greater than the dynamic pressure corresponding to the helicopter's forward speed.

Strength of wake.- The measurements of reference 15 were made behind a very lightly loaded rotor; the disk load was only 96 Pa (2 lb/ft<sup>2</sup>). Current rotor designs are much more heavily loaded, with disk loads of 287 Pa (6 lb/ft<sup>2</sup>) being relatively common. These more heavily loaded rotors produce substantially stronger wakes.

A gross indication of the magnitude of the induced velocities behind a modern rotor can be obtained from momentum theory (ref. 29). The usual non-dimensional form of the theoretical results for level flight is shown in figure 3. All of the results are presented in terms of a reference velocity

$$w_h = \sqrt{\frac{T}{2\rho\pi R^2}} = V \sqrt{\frac{C_L}{\pi A}}$$

(The two forms of  $w_h$  are identical when it is recognized that the aspect ratio of a single rotor is  $4/\pi$ .) The average induced velocity over the rotor is  $w_0$ . This average velocity doubles in the wake and local values of induced velocity three to four times as great as  $w_0$  may be found. Nevertheless,  $w_0$  provides a reasonable measure by which to compare the severity of different wakes.

The induced power required by a rotor is supplied directly by the rotor shaft and never appears as an external force at the aircraft. In a sense, this is one reason that a helicopter can hover. Autogyros and wings are different. In these cases, the induced losses appear as an external drag which must be overcome either by a separate propulsion system or by loss of altitude. As the speed is decreased, the induced drag vector tilts further and further rearward until it finally starts to decrease the lift. As a result (ref. 30), wings and autorotating rotors follow a curve different from that for helicopters, as shown in figure 3. The difference is not significant for wings since impossibly large lift coefficients would be required to reach such low speeds; however, figure 3 indicates the existence of minimum possible speeds for autogyros that will be addressed in a later section of this paper.

Comparison with B747.- The nondimensionalization of velocities in figure 3 masks the true character of the theoretical results. Figure 4 uses appropriate values of  $w_h$  to compare directly the induced velocities of helicopters with those for a B747-200F on approach at maximum landing weight (2.80 MN (630 000 lbf)). This wide-body aircraft approaches at about 72 m/s (140 knots) at a lift coefficient of about 1.8. Corresponding curves are shown for single rotor helicopters with disk loads from 96 Pa (2 lbf/ft<sup>2</sup>) to 479 Pa (10 lbf/ft<sup>2</sup>). For reference, the following table lists a few current helicopters and their disk loads:

| Helicopter |        | Disk Load |                     |
|------------|--------|-----------|---------------------|
|            |        | Pa        | lbf/ft <sup>2</sup> |
| Bell       | TH-13T | 131       | 2.73                |
|            | 206-L1 | 181       | 3.77                |
|            | 214B   | 337       | 7.03                |
|            | 222    | 294       | 6.15                |
|            | AH-1G  | 299       | 6.25                |
| Enstron    | F28A   | 128       | 2.67                |
| Hughes     | 300C   | 174       | 3.63                |
|            | 500C   | 216       | 4.52                |
| Sikorsky   | S61L   | 301       | 6.29                |
|            | S64F   | 548       | 11.45               |
|            | S76    | 315       | 6.58                |

At identical forward speeds, single rotor helicopters with disk loads of this magnitude have significantly lower induced velocities than the wide-body transport. On the other hand, the helicopters can fly slower, and the induced velocities are much greater at low speed. For example, a helicopter with a disk load of 287 Pa (6 lbf/ft<sup>2</sup>) and operating at a speed of about 21 m/s (40 knots) produces the same average induced velocity as a B747-200F on landing approach.

Vortex hazard.- The evaluation of vortex hazard is a complex business involving many factors such as span, spanwise load distribution, and wake roll-up. Nevertheless, the simple order-of-magnitude analysis of figure 4 indicates that helicopters produce wakes of such significant strength that they must be treated with respect. Helicopter pilots and air traffic controllers should be constantly aware of the unseen hazard in the wake of a helicopter. Fatal accidents involving light planes intercepting helicopter wakes have already occurred. Indeed, the experimental study of reference 31 was initiated as a consequence of one fatal accident twenty years ago in Chicago.

Tandem rotors.- Figure 4 applies only to single rotor helicopters. A tandem helicopter involves additional considerations as indicated in figure 5. A single rotor produces an induced velocity of  $w_0$  over itself and this velocity doubles to  $2w_0$  in its wake. For equally loaded tandem rotors, each rotor induces a velocity of  $w_0$  over itself; however, the rear rotor sees the fully developed downwash of the front rotor ( $2w_0$ ) as well. The total downwash at the rear rotor is  $3w_0$  and it requires three times as much induced power as the front rotor. This fact has been confirmed repeatedly by experiment (refs. 14, 21, 32, and 33). In the wake, the self-induced velocity of the rear rotor also doubles so that the total induced velocity is  $4w_0$ . As a result, for equal disk load, the velocities in the wake of a tandem rotor helicopter are twice those of a single rotor helicopter. The values for the tandem helicopter are compared with those for a B747 in figure 6. Evidently, for a machine such as the Boeing-Vertol 234 LR (with a disk load of 432 Pa (9.02 lbf/ft<sup>2</sup>)), the wake velocities are of the same magnitude as those of the B747 even at the same forward speeds. Particular caution should be used when following, or crossing behind, such loaded tandem rotor helicopters.

#### PARTIAL POWER DESCENT

Accident rates.- Partial power descent and autorotational landings combine to produce a startling large accident rate. Table I (from ref. 34) shows the toll from U.S. Army autorotation accidents for three fiscal years during the Southeast Asia conflict. For these three years, there were 790 accidents costing almost \$90,000,000 and 92 lives. Table II shows that, for the same three years, autorotation accidents accounted for 42 percent of all Army helicopter accidents. These accidents were not confined to novice pilots. Figure 7 shows the accident rate by helicopter type. The training helicopters, notwithstanding their use by novices, have the lowest accident rate. Instead, there is a gross trend, with some exceptions, to higher accident rates as the helicopter disk load is increased. This trend indicates an impact of the induced flow-field, since its magnitude and effects depend heavily on disk load.

Vertical descent.- Even before the advent of successful autogyros and helicopters (ref. 2), the unusual flow-field of a rotor in vertical descent had drawn attention. Subsequent investigators contributed numerous empirical and flow visualization studies (refs. 1, 3-6).

Pilots are aware that the public image of helicopters descending rapidly in a vertical path is simply not a fact of life. Vertical descent is an operation



to be accomplished very slowly, carefully, and only at final touchdown. Even so, vertical descent is a logical place to begin a discussion of descent because it allows a simple grasp of many concepts which apply to the more practical case of inclined descent.

Flow in vertical descent.- One of the most striking flow studies is that of reference 6 from which figure 8 was prepared. Figure 8(a) shows the wake of a hovering helicopter which gathers air, largely from above the rotor, and funnels it downward to produce lift. As soon as the rotor begins to descend (fig. 8(b)), its motion produces a flow upward past the rotor opposing the induced flow, until the so-called point of ideal autorotation is reached (fig. 8(c)). For this condition, the mean induced velocity is just cancelled by the helicopter's rate of descent. The flow becomes more violent as the rate of descent increases further (fig. 8(d) and 8(e), and then finally smooths out again at very high rates of descent where the rotor operates in a true windmill-brake mode.

The highly disorganized flow shown in figures 8(b) to 8(c) is termed the vortex-ring state. Although large vortices are present, there is no semblance to the regular ring-like vortices which are usually conjured up by the name "vortex-ring state." This flow is so complicated and unsteady that no complete treatment has ever been attempted. Instead, only simple one-dimensional analyses are used. These treatments are usually referred to as momentum theory.

Even momentum theory has problems in descent. At "ideal autorotation" where the descent velocity equals the average induced velocity ( $V_G = w_0$ ), this simple theory obtains zero flow through the rotor. Under such circumstances, it requires an infinite induced velocity to produce thrust. This theoretical result is shown in figure 9, where it is compared with experimental measurements from references 5 and 35. The measurements of reference 5 are time-averaged results and are shown by symbols; the measurements of reference 35 are instantaneous values and are shown by the cross-hatched band.

As might be anticipated, the infinite velocities of the simple theory are not found in practice. The rotor and the air exchange momentum to produce lift. As the descent velocity increases, the induced velocities increase more rapidly than in the theory; this is expected since the theory only yields the minimum possible values. Then at a descent velocity between 1.5 and 2  $w_h$ , the induced velocity drops precipitously to the lower theoretical curve which represents the windmill-brake state of operation.

Power in vertical descent.- A knowledge of the induced velocity is necessary for the designer to estimate performance, but it has little meaning to the pilot. Figure 10 shows the data of figure 9 after conversion to nondimensionalized shaft power. The ordinate is the induced shaft power divided by the induced shaft power in hover. This figure is in more meaningful terms to a pilot since  $V_G$  is his descent velocity, and he controls power either directly through the throttle or indirectly through the engine-governor response to his collective pitch commands.

Power stability.- If the rotor operated at constant efficiency for all descent rates, the power required to climb or descend would be just equal to the

rate of gain of potential energy; that is,  $P_c = \dot{E} = -TV_G$ . This power is shown as a dashed line in figure 10. Unfortunately, the rotor efficiency becomes poorer as the descent velocity increases. According to theory (ref. 30), the power change for small rates of climb or descent is just one-half the rate of change of potential energy ( $E$ ). The experimental measurements indicate an even more difficult situation in which there is essentially no change in power for rates of descent as great as 1.5 times  $w_h$ . Thus, the power stability is essentially neutral and it is difficult to control rates of descent with precision.

Reversed control response.- At large rates of descent, there is the possibility of a reversed response to power or collective pitch. For example, consider a helicopter established in vertical descent at a velocity  $V_G$  approaching  $2w_h$ . Collective pitch is applied to check the descent. The thrust and induced velocity respond promptly, increasing  $P_h = T_{w_h} = \tau^{3/2} \sqrt{2\rho\pi R^2}$ . The descent rate changes only slowly since it requires a change in acceleration of the entire mass of the helicopter. The result is a major and rapid increase in shaft power which may overpower the engine governor. If so, the rotor slows down, the thrust decreases, and the cycle repeats. Eventually, the desired correction may be obtained, but there is likely to be a considerable loss in altitude before the final equilibrium state is reached.

Obviously, rapid vertical descent should be avoided. If a task demands vertical descent, such as the placement of an external sling load in a confined area, the descent should be made from the minimum possible height and as slowly and carefully as possible.

It is interesting to note that the rotor can be considered simply as a drag producing device in vertical autorotation. As such, it has a drag coefficient of about 1.15 (ref. 36). This is roughly equivalent to the drag produced by a parachute with a diameter equal to that of the rotor.

Power in inclined descent.- Calculation of power in inclined descent becomes more complicated since it is necessary to consider both the glide-slope angle and the rotor tip-path plane inclination as well as the speed along the flight path. Figure 11 presents the nondimensional shaft power as a function of glide-slope angle for three rotor inclinations:  $-10^\circ$  (tipped forward);  $0^\circ$  (level), and  $10^\circ$  (tipped rearward). For relatively mild descent angles, less than about  $15^\circ$ , the power decreases as the glide slope increases. This trend conforms to the pilot's instinctive feel for power stability; that is, an increase in descent rate results from a decrease in throttle setting (or collective pitch). At large descent angles however a point may be reached at which the power trend reverses; that is, a stabilized steep glideslope requires more power than a shallower slope. The increase in power required is very sharp and abrupt for glide slopes in excess of  $60^\circ$  and for speeds less than  $2w_h$ . This sudden increase has a magnitude as great as the total induced power normally required to hover.

At relatively low speeds and on steep glide slopes, the instruments in the helicopter are subject to large errors. Thus, the pilot flies by reference to the ground, either visually or by means of instrument landing systems. He can sense sidewinds as a drift, but his perception of a steady head wind or tail

wind is poor. If stabilized on a steep glide slope, the forward component of speed is small. If a light tail wind springs up, the glide slope with respect to the air (rather than the ground) can steepen by  $10^\circ$  to  $15^\circ$  with no warning other than an astounding and sudden increase in power required. Because of the increased power requirement the helicopter settles faster, further increasing the glide slope and further increasing the power requirement.

Power settling.- Operationally, the appearance of this phenomenon is sudden and unexpected. It is generally termed power settling; however, one of our research pilots refers to it more descriptively as "stepping into the sink hole." A pilot may negotiate a combination of geometric slope and speed so many times that he is confident of its safety; however, on the next approach, he may encounter a tailwind that produces disastrous consequences.

The normal reaction of a pilot to excessive sink rates is to increase collective pitch and power. Unfortunately, for reasons discussed earlier with respect to vertical descent, this procedure may only increase the descent rate. The proper procedure is the rapid application of forward cyclic until the speed increases and, only then, an increase in power. Obviously, such a recovery will entail a substantial loss in altitude.

Examination of figure 11 shows that rearward rotor inclinations result in power settling at shallower glide slopes. Pilots should be particularly careful to avoid large or rapid applications of rearward cyclic when on steep approaches.

Operational restraint.- The best way to treat power settling is to avoid it. All too often, the flight manual treats this subject cavalierly with a one-line sentence such as, "Avoid partial-power descent." More specific rules can be obtained by an examination of the complete results of reference 30. Power settling will not be encountered if the speed on the glide slope is greater than twice  $w_h$ . This restriction often results in full autorotation, and the descent rates may be uncomfortably rapid. As an alternative, keep the descent shallow. Power settling should not be encountered if the glide slope is shallow. A reasonable limitation to glide slopes of no more than  $10^\circ$  or  $15^\circ$  should provide adequate margins of safety.

#### MINIMUM SPEEDS FOR AUTOGYROS

Theoretical results.- Reference 30 also examines the minimum speeds for autorotation. This subject was noted earlier in the discussion of figure 1. The minimum possible speed is a direct function of  $w_h$  and depends to some extent upon glide slope. For level flight, the minimum speed is

$$V_{\min} = \sqrt[4]{\frac{3^3}{2^2}} w_h = 1.6118 w_h$$

When descending, the minimum speed along the flight path occurs at a glide slope of  $45^\circ$  with a rotor inclination of  $0^\circ$  (with respect to the horizon) and this speed is

$$V_{\min} = \sqrt{2} w_h = 1.414 w_h$$

If only the horizontal component of speed is measured in this latter case (such as by a pace car on the ground), the apparent minimum speed would be

$$V_{\min} = w_h$$

Comparison with advertised values.- Figure 12 compares these theoretical values with the values given in Janes, where minimum speeds are described variously as "minimum," "minimum level flight," "approach," or "landing." Considering the crude nature of the theory, the inadequacies of low-speed aerodynamic on-board instrumentation, and the less-than-precise terminology in Janes, the agreement between theory and the stated speeds appears reasonably good. Only two "landing" speeds fall far below the theoretical curves, and these machines are known to have a high accident rate.

The autogyros of figure 12 tend to have lower disk loads than helicopters; however, a helicopter with a failed engine immediately becomes an autogyro. Appropriate minimum speeds for these more heavily loaded "autogyros" can be calculated rapidly from the foregoing equations.

#### GROUND EFFECT IN HOVERING

Power.- Helicopters generally experience a large and useful increase in performance when hovering in ground effect. Ground effect has been studied theoretically (refs. 7, 21, and 37) and experimentally (for example, refs. 8, 38, and 39). The theoretical treatments postulate a stylized, rigid, cylindrical wake extending from the rotor to the ground. It does not even deform to let the wake escape laterally along the ground. Although this simple scheme has limitations (ref. 37), it does yield reasonable results. The initial study by Knight and Hefner (ref. 7) is still valid; it has merely been extended to different cases and to different rotor load-distributions.

Flow field.- Even the extreme difference between uniform and triangular disk-load distributions makes little difference in the required power (fig. 13); however, it does make a major difference in the flow field below the rotor. Figure 14 (from ref. 21) shows theoretical contours of downwash near a rotor operating at a height of one rotor radius. A uniformly loaded rotor would have almost uniform velocities between itself and the ground; however, the rotor of figure 14 has a triangular loading which results in a large region of upwash below the center of the rotor. Earlier dust-flow photographs in reference 8 (fig. 15) had shown this region; however, it has been thought to be the wake of the large hub. In any event, independent confirmation of this effect (ref. 39) was provided very shortly after the publication of reference 21.

## GROUND EFFECT IN FORWARD FLIGHT

Theoretical Considerations.- Theoretical study of ground effect in forward flight lagged far behind similar studies in hovering. Only one approximate analysis (ref. 40) was published prior to 1960. Another approximate analysis (ref. 41) did provide some interesting qualitative results. This study assumed a wake similar to that of Knight and Hefner with one exception -- the wake was blown rearward, or skewed, by the forward velocity of the rotor. The skew angle of the wake is termed  $\chi$  and reference 29 had already shown that, in free air, the induced velocity at the rotor would vary as  $\sqrt{\cos \chi}$  as the speed and  $\chi$  increased. Ground effect was obtained as an upwash opposing the rotor wake, and decreasing as  $\cos^4 \chi$ . This result indicated that in ground effect the maximum power requirement would occur at some forward speed rather than in hovering.

A reasonably complete treatment of ground effect for helicopter (ref. 42) was not achieved until recently and then only as the function of years of research (beginning with references 43-45) on the related problem of wind-tunnel wall interference. Rotary wing ground effect was complicated because the ground induces, not only an upwash, but also horizontal velocities which effectively reduce the airspeed of the rotor. Furthermore, these ground-induced velocities of such great magnitude that it is necessary to consider them in establishing the momentum balance of the rotor.

Power in ground effect.- The theoretical results of reference 42 are shown in figure 16 for a rotor with a triangular disk loading. Normally, the rotor is at a height of 0.3 to 0.4 of the rotor radius while resting on the ground. Figure 16 shows the power for even lower rotor heights merely to accentuate the trends. At all heights, in ground effect, the maximum power occurs at some forward speed; this speed increases as the rotor height decreases. Ground effect is often used to lift overloads greater than the free-air hovering capability of the helicopter; however, it is not enough to barely clear the ground. Unless an altitude providing several feet of clearance can be obtained, the combination of the loss of ground effect with speed, and the additional power required to accelerate, may result in contact with the ground. This subject has been covered in reference 46, which provides some rules for UH-1 class helicopters.

The peculiar loops in the power curves at  $H/R = 0.1$  are of interest. Obviously, a massive helicopter does not oscillate in speed to follow such a power curve. Instead, it jumps discontinuously across the theoretical curves through this range of speeds. This is most evident in the wake, which is more vertical than in free air at low speeds in ground effect, and then suddenly jumps upward to a nearly horizontal position. This trend has been observed experimentally in references 47 and 48.

The powerful influence of the horizontal ground-induced velocity can be seen by comparing figures 16 and 17. The numerical values are identical; the only difference is that figure 17 is plotted against  $V + \Delta u$ , the effective airspeed, while figure 16 was plotted against  $V$ , the apparent airspeed. As a result, the curves of figure 17 are smooth and unremarkable compared to those of figure 16. The reason is simply the large effective reduction in rotor speed caused by ground effect. This speed reduction can be observed in a steeply flared touchdown. The rearward tilt of the rotor allows part of the forward

speed to pass upward through the rotor. When combined with ground effect, which is actually greater for rearward tilt (ref. 42), the result is a brief passage through the vortex-ring state (fig. 18) as evidenced by a shuddering vibration of the helicopter. Other than the vibratory stress levels, there is no particular danger here; the speed and the altitude are both too low.

No theory is complete without experimental verification. Figure 19 compares the theoretical power calculations with wind tunnel measurements from reference 49. Experimentally, the effects of the ground on power are even more pronounced than they are in the theory.

### YAW CONTROL IN GROUND EFFECT

Loss of Yaw Control.- Tail rotors had always been simply an appendage tacked on to a helicopter to overcome rotor torque and to provide yaw control. They seldom received the same attention as the main rotor since their power consumption was an order of magnitude less than that required by the main rotor. This situation changed dramatically when one of our combat helicopters suffered total losses of yaw control while hovering with winds in ground effect (ref. 50). Many experimental studies of the problem were initiated (refs. 49-56). The importance of tail-rotor problems was signified by the total dedication of the October 1970 issue of the Journal of the American Helicopter Society to that subject. A recent survey of this problem and other tail rotor problems is presented in reference 57.

A major factor in the yaw-control problem turned out to be almost identical to a problem encountered earlier in studies of wind-tunnel testing techniques. Experimental (refs. 48 and 58) and theoretical (refs. 59 and 60) studies of the problem already existed and the observed effects had not been recognized as a potential real operational problem.

Flow-Field in Ground Effect.- The effect of the ground on the rotor wake is illustrated in figures 20 to 26 (from ref. 60). In each case, the figure on the right shows the flow in ground effect by presenting flow vectors in a vertical longitudinal plane through the rotor hub and on the ground below the rotor. The figure on the left shows the flow at the same locations out of ground effect. The rotor itself, indicated by the upper ellipse, is 2.6 rotor radii above the ground. This is a height generally considered to be out of ground effect. The intersections of the rotor wake on the planes of the vectors are also shown.

Figure 20 shows the flow for a relatively high speed condition. There is little difference between the flows in ground effect and free air except very close to the point at which the wake reaches the ground. As the speed decreases, the wake skew angle also decreases. At  $\chi = 60^\circ$  (fig. 21), the disturbances at the ground increase and the flow is retarded immediately in front of the wake. At a still lower skew angle of  $\chi = 50^\circ$  (fig. 22), the flow in front of the wake at the ground is essentially zero. At  $\chi = 40^\circ$  (fig. 23), the flow is distinctly reversed at this point, and the reversed flow region increases in size and velocity as the wake continues to steepen (figs. 24-26).

Ground Vortex.- The deformations of the wake which occur in real life, but are not allowed in theory, further increase magnitude the reversed flow (ref. 59). The result is a strong large vortex on the ground which passes off to each side in a "horseshoe" pattern (fig. 27). In the case of the combat helicopter, this vortex immersed the tail rotor when the wind was from behind. The vortex and the tail rotor turned in the same direction, effectively decreasing the rotational speed and thrust of the tail rotor. The reduced tail-rotor thrust, in combination with unstable fin and fuselage moments in rearward flow, resulted in uncontrolled yaw. Recovery was only possible after approximately a 180° rotation of the aircraft.

The design of this particular helicopter was such all these events combined to produce an unusually difficult situation. Even though total loss of control may not occur on other machines, elements of the same problem exist. A pilot should always remember that hovering with respect to the ground is not the same as a true hover because of the presence of winds. Control will be much simpler if it is possible to determine the direction of the ambient winds and to plan "hovering" maneuvers such that the aircraft headed into that wind.

#### LATERAL CONTROL IN GROUND EFFECT

The longitudinal nonuniformity of induced flow over the rotor has a major influence on lateral trim requirements in forward flight. Figure 28 shows the theoretical (ref. 42) distribution of ground-induced upwash over the longitudinal axis of a rotor at low speed. It will be seen that this upwash is large in magnitude, and that it increases as the ground clearance decreases. Furthermore, the upwash increases from the leading to the trailing edge of the rotor disk. This trend is exactly opposite to that generated by the rotor itself in free air where downwash increases toward the trailing edge. Consequently, the lateral control requirements should decrease in ground effect.

The wind-tunnel tests of reference 49 employed a model of the YUH-61A helicopter which has a hingeless rotor. Because of the lack of hinges, hub rolling moments at fixed cyclic pitch settings illustrate the lateral control requirements. The data, shown in figure 29, confirms the predicted reduction in lateral control as height above the ground is reduced. Furthermore, at the lowest height, it shows that the effect of the ground vortex is not confined to yaw control; it also produces decided nonlinearities in lateral control as the ground vortex moves under the rotor.

#### CONCLUDING REMARKS

Wind-tunnel measurements show that the wake of a rotor, except at near-hovering speeds, is not like that of a propeller. The wake is more like that of a wing except that, because of the slow speeds, the wake velocities may be much greater. The helicopter can produce a wake hazard to following light aircraft that is disproportionately great compared to an equivalent fixed-wing aircraft. This hazard should be recognized by both pilots and airport controllers when operating in congested areas.

Even simple momentum theory shows that, in autorotation and partial-power descent, the required power is a complex function of both airspeed and descent angle. The power required may increase violently, rather than decrease, with rate of descent. The nonlinear characteristic, together with an almost total lack of usable instrumentation at low airspeeds, has led to numerous "power-settling" accidents. Simple rules can avoid the regions in which these accidents occur.

The same theory shows that there is a minimum forward speed at which a rotor can autorotate. Neglect of, or inadequate appraisal of, this minimum speed has led to numerous accidents.

Ground effect is generally counted as a blessing since it allows overloaded takeoffs; however, it also introduces additional operation problems. These problems include premature blade stall in hover, settling in forward transition, shuddering in approach to touchdown, and complications with yaw control. Some of these problems have been treated analytically in an approximate manner and reasonable experiment agreement has been obtained. An awareness of these effects can prepare the user for their appearance and their consequences.

#### REFERENCES

1. Glauert, H.: A General Theory of the Autogyro. R&M No. 1111, British A.R.C., 1926.
2. DeBothezat, George: The General Theory of Blade Screws. NACA Rept. 29, 1918.
3. Lock, C. N. H.; Bateman, H.; and Townsend, H. C. H.: An Extension of the Vortex Theory of Airscrews of Small Pitch, Including Experimental Results. R&M No. 1014, British A.R.C., 1926.
4. Drees, J. Meijer: A Theory of Airflow Through Rotors and Its Application to Some Helicopter Problems. Journ. Helicopter Assoc. of Great Britain, Vol. 3, No. 2, July, Aug., Sept., 1949. pp 79-104.
5. Castles, Walter, Jr.; and Gray, Robin B.: Empirical Relation Between Induced Velocity, Thrust, and Rate of Descent of a Helicopter Rotor as Determined by Wind-Tunnel Tests on Four Model Rotors. NACA TN 2474, 1951.
6. Drees, J. Meijer; and Hendaal, W. P.: Airflow Patterns in the Neighborhood of Helicopter Rotors. Aircraft Engineering, April 1951. pp. 107-111.
7. Knight, Montgomery; and Hefner, Ralph A.: Analysis of Ground Effect on the Lifting Airscrew. NACA TN 835, 1941.
8. Taylor, Marion K.: A Balsa-Dust Technique for Airflow Visualization and Its Application to Flow Through Model Helicopter Rotors in Static Thrust. NACA TN 2220, 1950.



9. Wald, Quentin: A Method for Rapid Estimation of Helicopter Performance. Jour. Aero. Sci., Vol. 10, No. 4, April 1943. pp. 131-135.
10. Coleman, Robert P.; Feingold, Arnold M.; and Stempin, Carl W.: Evaluation of the Induced-Velocity Field of an Idealized Helicopter Rotor. NACA WR L-126, 1945. (Formerly NACA ARR L5E10.)
11. Mangler, K. W.; and Squire, H. B.: The Induced Velocity Field of a Rotor. R&M No. 2642, British, A.R.C., 1950.
12. Castles, Walter, Jr.; and DeLeeuw, Jacob Henri: The Normal Component of Induced Velocity in the Vicinity of a Lifting Rotor and Some Examples of Its Application. NACA REP. 1184, 1954. (Supersedes NACA TN 2912.)
13. Gessow, Alfred: Review of Information on Induced Flow of a Lifting Rotor. NACA TN 3238, 1954.
14. Heyson, Harry H.: Preliminary Results From Flow-Field Measurements Around Single and Tandem Rotors in the Langley Full-Scale Tunnel. NACA TN 3242, 1954.
15. Heyson, Harry H.; and Katzoff, S.: Induced Velocities Near a Lifting Rotor With Nonuniform Disk Loading. NASA Rep. 1319, 1957. (Supersedes NACA TN 3690 by Heyson and Katzoff and NACA TN 3691 by Heyson.)
16. Castles, Walter, Jr.; and Durham, Howard L., Jr.: Distribution of Normal Component of Induced Velocity in the Lateral Plane of a Lifting Rotor. NACA TN 3841, 1956.
17. Castles, Walter, Jr.; Durham, Howard L., Jr.; and Kevorkian, Jirair: Normal Component of Induced Velocity for Entire Field of a Uniformly Loaded Lifting Rotor with Highly Swept Wake as Determined by Electro-Magnetic Analogy. NASA TR R-41, 1959. (Supersedes NACA TN 4238, 1958.)
18. Jewel, Joseph W., Jr.; and Heyson, Harry H.: Charts of the Induced Velocities Near a Lifting Rotor. NASA MEMO 4-15-59L, 1959.
19. Heyson, Harry H.: A Note on the Mean Value of Induced Velocity for a Helicopter Rotor. NASA TN D-240, 1960.
20. Heyson, Harry H.: Equations for the Induced Velocities Near a Lifting Rotor with Nonuniform Aximuthwise Vorticity Distribution. NASA TN D-394, 1960.
21. Heyson, Harry H.: Induced Flow Near a Rotor and Its Application to Helicopter Problems. Proceed. 14th Ann. Natl. Forum, Amer. Helicopter Soc., April 16-19, 1958. (Also available as: Induced Flow Near a Helicopter Rotor. Aircraft Engineering, Vol. 31, No. 360, February 1959. pp. 40-44.)

22. Rabbott, John P., Jr.; and Churchill, Gary B.: Experimental Investigation of the Aerodynamic Loading on a Helicopter Rotor in Forward Flight. NACA RM L56107, 1956.
23. Piziali, Raymond A.; and DuWaldt, Frank A.: A Method for Computing Rotary Wing Airload Distribution in Forward Flight. TRECOM TR 62-44, 1962.
24. Daughaday, H.; and Piziali, R. A.: An Improved Computational Model for Predicting the Unsteady Aerodynamic Loads of Rotor Blades. Jour. Amer. Helicopter Soc., Vol. 11, No. 4, October 1966. pp 3-10.
25. Piziali, R. A.: A Method for Predicting the Aerodynamic Loads and Dynamic Response for Rotor Blades. USAAVLABS TR 65-74, 1966.
26. Crimi, Peter: Prediction of Rotor Wake Flows. CAL/USAFFVLABS Symposium on Aerodynamic Problems Associated with V/STOL Aircraft. Buffalo, NY, June 1966, Vol. I.
27. Sadler, S. Gene: Development and Application of a Method for Predicting Free Wake Positions and Resulting Rotor Blade Air Loads. Vol. I - Model and Results, NASA CR-1911, 1971; Vol II - Program Listings, NASA CR-1912, 1971.
28. Sadler, S. Gene: Main Rotor Free Wake Geometry Effects on Blade Air Loads and Response for Helicopters in Steady Maneuvers. Vol. I - Theoretical Formulation and Analysis of Results, NASA CR-2110, 1972; Vol. II - Program Listings, NASA CR-2111, 1972.
29. Heyson, Harry H.: Nomographic Solution of the Momentum Equation for VTOL-STOL Aircraft. NASA TN D-814, 1961. (Also available as: V/STOL Momentum Equation, Space/Aeron. Vol. 38, No. 2, July 1962. pp B-18 to B-20.
30. Heyson, Harry H: A Momentum Analysis of Helicopters and Autogyros in Inclined Descent, With Comments on Operational Restrictions. Appendix: Comparison of the Maximum Performance Obtainable from Autorotating Rotors and Finite Wings. NASA TN D-7917, 1975.
31. Conner. Andrew B.; and O'Bryan, Thomas C.: A Brief Evaluation of Helicopter Wake as a Potential Operational Hazard to Aircraft. NASA TN D-1227, 1962.
32. Dingeldein, Richard C.: Wind-Tunnel Studies of the Performance of Multi-rotor Configurations. NACA TN 3236, 1954.
33. Huston, Robert J.: Wind-Tunnel Measurements of Performance, Blade Motions, and Blade Air Loads for Tandem Rotor Configurations With and Without Overlap. NASA TN D-1971, 1963.
34. Kimball, Kent A.; Harden, Donald F.; and Hofmann, Mark A.; Army Auto-rotational Accidents. Paper No. 14, AGARD-CP-134, 1973.

35. Washizu, Kyuickiro; Azuma, Akira; Koo, Jiro; and Oka, Toichi: Experiments on a Model Helicopter Rotor Operating in the Vortex Ring State. Jour. Aircraft, Vol. 3, No. 3, May-June 1966. pp. 225-230.
36. Gustafson, F. B.; and Gessow, Alfred: Flight Tests on the Sikorsky HNS-1 (Army YR-4B) Helicopter. II - Hovering and Vertical Flight Performance with the Original and an Alternate Set of Main-Rotor Blades, Including a Comparison with Hovering Performance Theory. NACA WR L-596. (Formerly NACA MR L5D09A) 1975.
37. Heyson, Harry H.: Evaluation of Linearized Vortex Theory as Applied to Single and Multiple Rotors Hovering In and Out of Ground Effect. NASA TN D-43, 1959.
38. Zbrozek, J.: Ground Effect on the Lifting Rotor. R & M No. 2347, British A.R.C., 1950.
39. Fradenburgh, Evan A.: Flow Field Measurements for a Hovering Rotor Near the Ground. Proceedings of the Am. Helicopter Soc. Fifth Annual Western Forum, Los Angeles, CA, Sept. 25-26, 1958.
40. Cheeseman, I. C.; and Bennett, W. E.: The Effect of the Ground on a Helicopter Rotor in Forward Flight. R & M No. 3021, British A.R.C., 1957.
41. Heyson, Harry H.: Ground Effect for Lifting Rotors in Forward Flight. NASA TN D-234, 1960.
42. Heyson, Harry H.: Theoretical Study of the Effect of Ground Proximity on the Induced Efficiency of Helicopter Rotors. NASA TM X-71951, May 1977.
43. Heyson, Harry H.: Jet-Boundary Corrections for Lifting Rotors Centered in Rectangular Wind Tunnels. NASA TR R-71, 1960.
44. Heyson, Harry H.: Wind-Tunnel Wall Interference and Ground Effect for VTOL-STOL Aircraft. Jour. Am. Helicopter Soc., Vol. 6, No. 1, January 1961. pp 1-9.
45. Heyson, Harry H.: Linearized Theory of Wind-Tunnel Jet-Boundary Corrections and Ground Effect for VTOL/STOL Aircraft. NASA TR R-124, 1962.
46. Schmitz, Fredric H.; and Vause, C. Rande: Near-Optimal Takeoff Policy for Heavily Loaded Helicopters Exiting From Confined Areas. Jour. Aircraft, Vol. 13, No. 6, May 1976. pp 343-348.
47. Jenkins, Julian L., Jr.: Trim Requirements and Static-Stability Derivatives from a Wind-Tunnel Investigation of a Lifting Rotor in Transition. NASA TN D-2655, 1965.
48. Rae, William H., Jr.; and Shindo, Shojiro: Comments on V/STOL Wind Tunnel Data at Low Forward Speeds. Proceed. Third CAL/AVLABS Symposium on Aerodynamics of Rotary Wing and V/STOL Aircraft, Buffalo, NY, June 18-20, 1969, Vol. 2.

49. Sheridan, Philip F.: Interactional Aerodynamics of the Single Rotor Helicopter Configuration. Vol. I - Final Report. AVRADCOM Report USARTL-TR-78-23A, September 1978.
50. Lewis, Richard B., III: Army Helicopter Performance Trends. Jour. American Helicopter Soc., Vol. 17, No. 2, April 1972. pp 15-23.
51. Huston, Robert J.; and Morris, Charles E. K., Jr.: A Note on a Phenomenon Affecting Helicopter Directional Control in Rearward Flight. Jour. Amer. Helicopter Soc., Vol. 15, No. 4, October 1970. pp 38-45.
52. Huston, Robert J.; and Morris, Charles E. K., Jr.: A Wind-Tunnel Investigation of Helicopter Directional Control in Rearward Flight in Ground Effect. NASA TN D-6118, 1971.
53. Wiesner, Wayne; and Kohler, Gary: Tail Rotor Performance in Presence of Main Rotor, Ground, and Winds. Jour. Amer. Helicopter Soc., Vol. 19, No. 3, July 1974. pp 2-9.
54. Yeager, William T., Jr.; Young, Warren H., Jr.; and Mantay, Wayne R.: A Wind-Tunnel Investigation of Parameters Affecting Helicopter Directional Control at Low Speeds in Ground Effect. NASA TN D-7694, 1974.
55. Sheridan, Philip F.; and Wiesner, Wayne: Aerodynamics of Helicopter Flight Near the Ground. Amer. Helicopter Soc. Preprint No. 77.33-04, 1977.
56. Sheridan, Philip R.; and Smith, Robert P.: Interactional Aerodynamics - A New Challenge to Helicopter Technology. Amer. Helicopter Soc. Preprint 79-59, May 1979.
57. Cook, C. V.: A Review of Tail Rotor Design and Performance. Vertica, Vol. 2, No. 3-4, 1979. pp 163-181.
58. Rae, William H., Jr.: Limits on Minimum-Speed V/STOL Wind-Tunnel Tests. Jour. Aircraft, Vol. 4, No. 3, May-June 1967. pp 249-254.
59. Heyson, Harry H.: The Flow Throughout a Wind Tunnel Containing a Rotor with a Sharply Deflected Wake. Proceed. Third CAL/AVLABS Symposium on Aerodynamics of Rotary Wing and V/STOL Aircraft. Buffalo, NY, June 18-20, 1969, Vol. 2.
60. Heyson, Harry H.: Theoretical Study of Conditions Limiting V/STOL Testing in Wind Tunnels with Solid Floor. NASA TN D-5819, 1970.

TABLE I.- COST OF AUTOROTATION ACCIDENTS

| F.Y.  | Number | Cost, \$   | Deaths | Injuries |
|-------|--------|------------|--------|----------|
| 70    | 395    | 44,364,000 | 43     | 360      |
| 71    | 289    | 35,614,000 | 31     | 222      |
| 72    | 106    | 9,312,000  | 18     | 70       |
| Total | 790    | 89,290,000 | 92     | 652      |

TABLE II.- PERCENTAGE OF TOTAL ACCIDENTS ATTRIBUTED TO AUTOROTATION

| F.Y.  | Total | Autorotation | %    |
|-------|-------|--------------|------|
| 70    | 944   | 395          | 41.8 |
| 71    | 632   | 289          | 45.7 |
| 72    | 293   | 106          | 36.2 |
| Total | 1869  | 790          | 42.3 |



# FLOW ANGLES BEHIND A ROTOR

$$\mu = 0.14 \quad X/R = 1.07$$

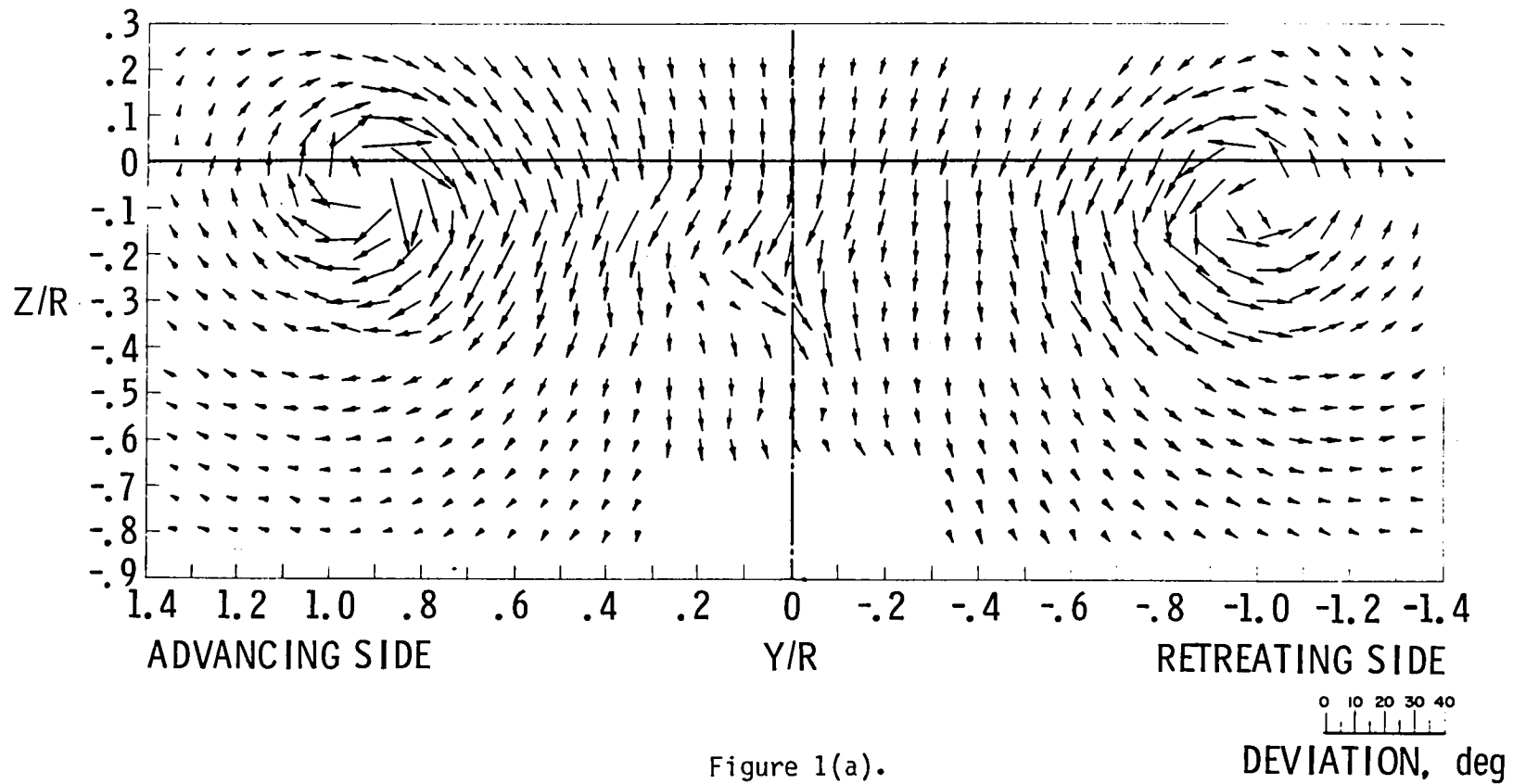

Figure 1(a).

# FLOW ANGLES BEHIND A ROTOR

$$\mu = .14 \quad X/R = 2.07$$

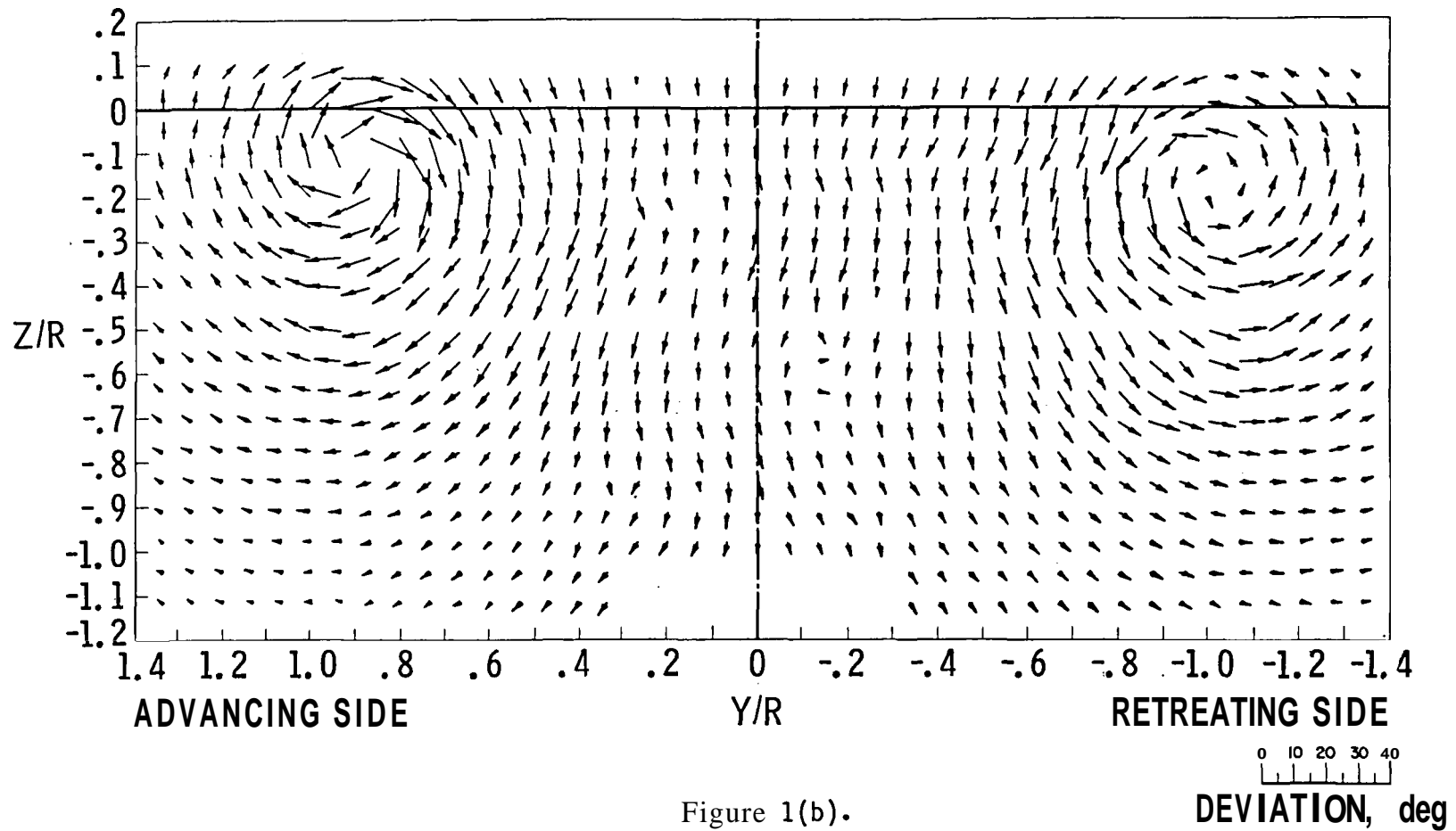
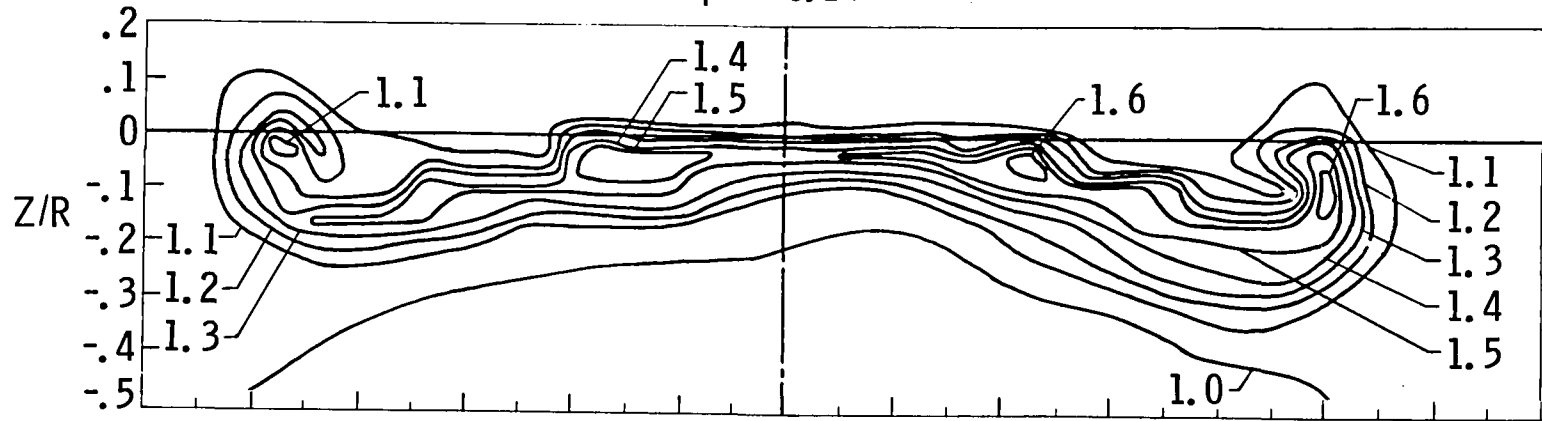

Figure 1(b).



# DYNAMIC PRESSURES BEHIND A ROTOR

$\mu = 0.14$



$x/R = 1.07$

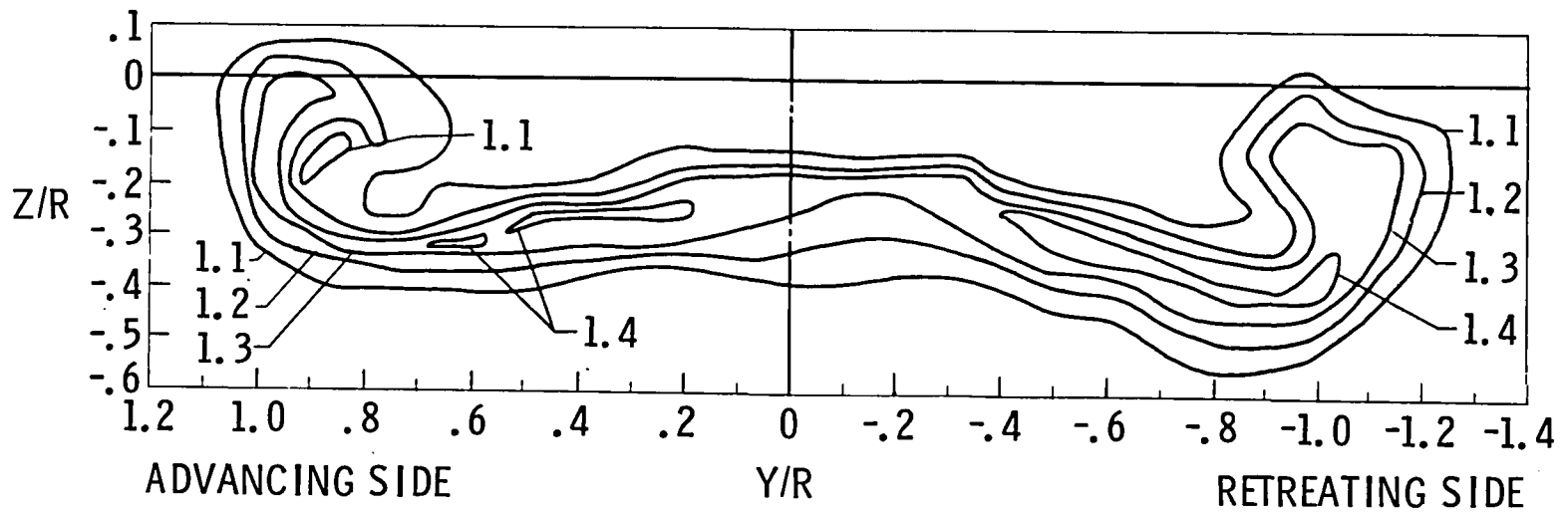

$x/R = 2.07$

Figure 2.

# INDUCED VELOCITIES OF LIFTING SYSTEMS

$$W_h = \sqrt{L/2\rho\pi R^2} = V \sqrt{C_L/\pi A}$$

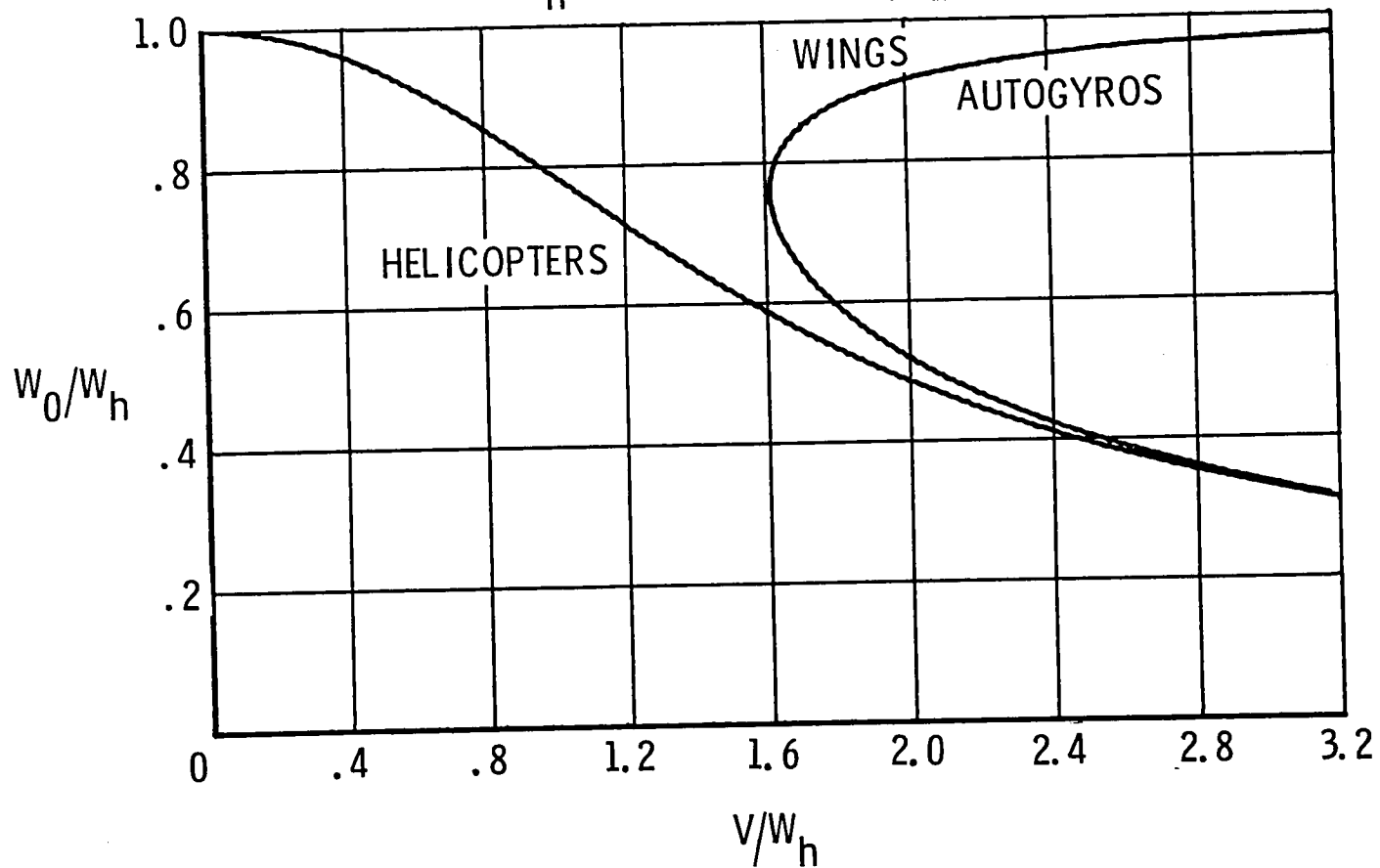

Figure 3.

# INDUCED VELOCITIES FOR SINGLE ROTORS

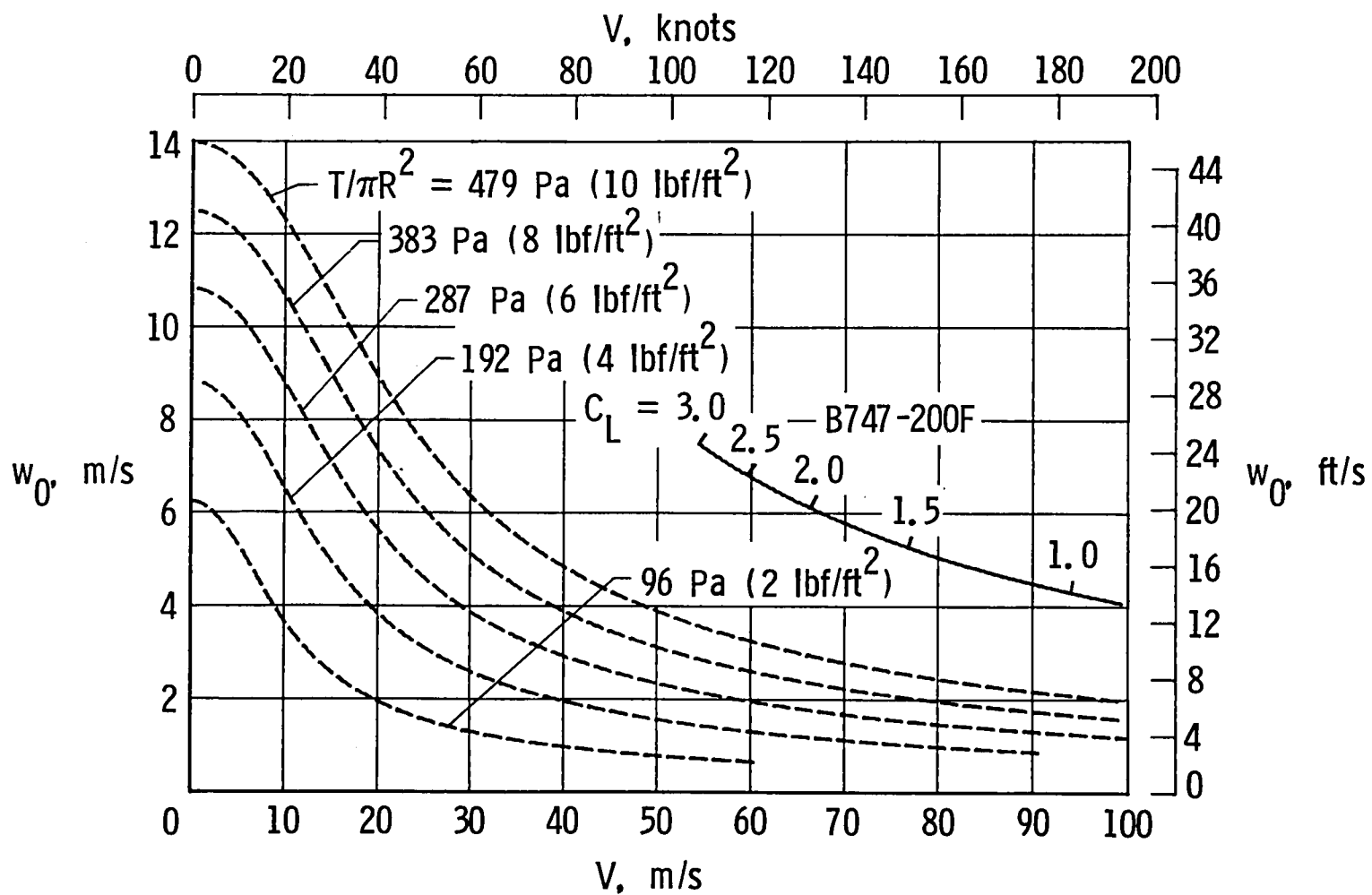
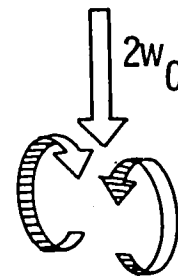
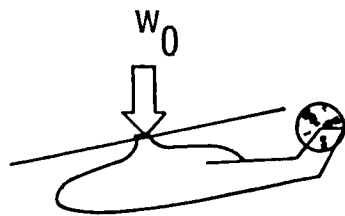

Figure 4.

# ROTOR WAKES

## SINGLE ROTOR



## TANDEM ROTOR

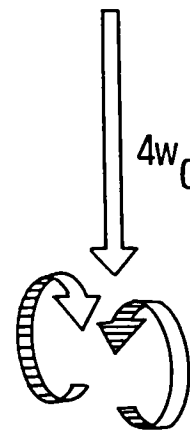
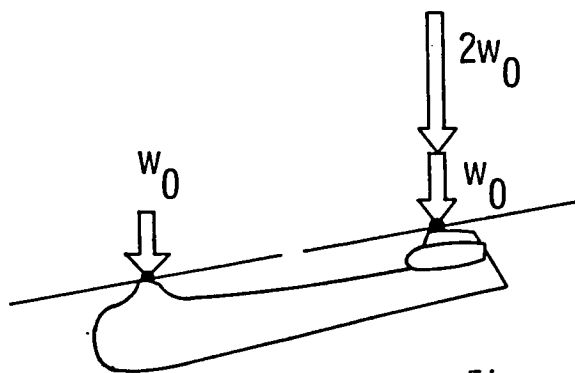

Figure 5.

# INDUCED VELOCITIES FOR TANDEM ROTORS

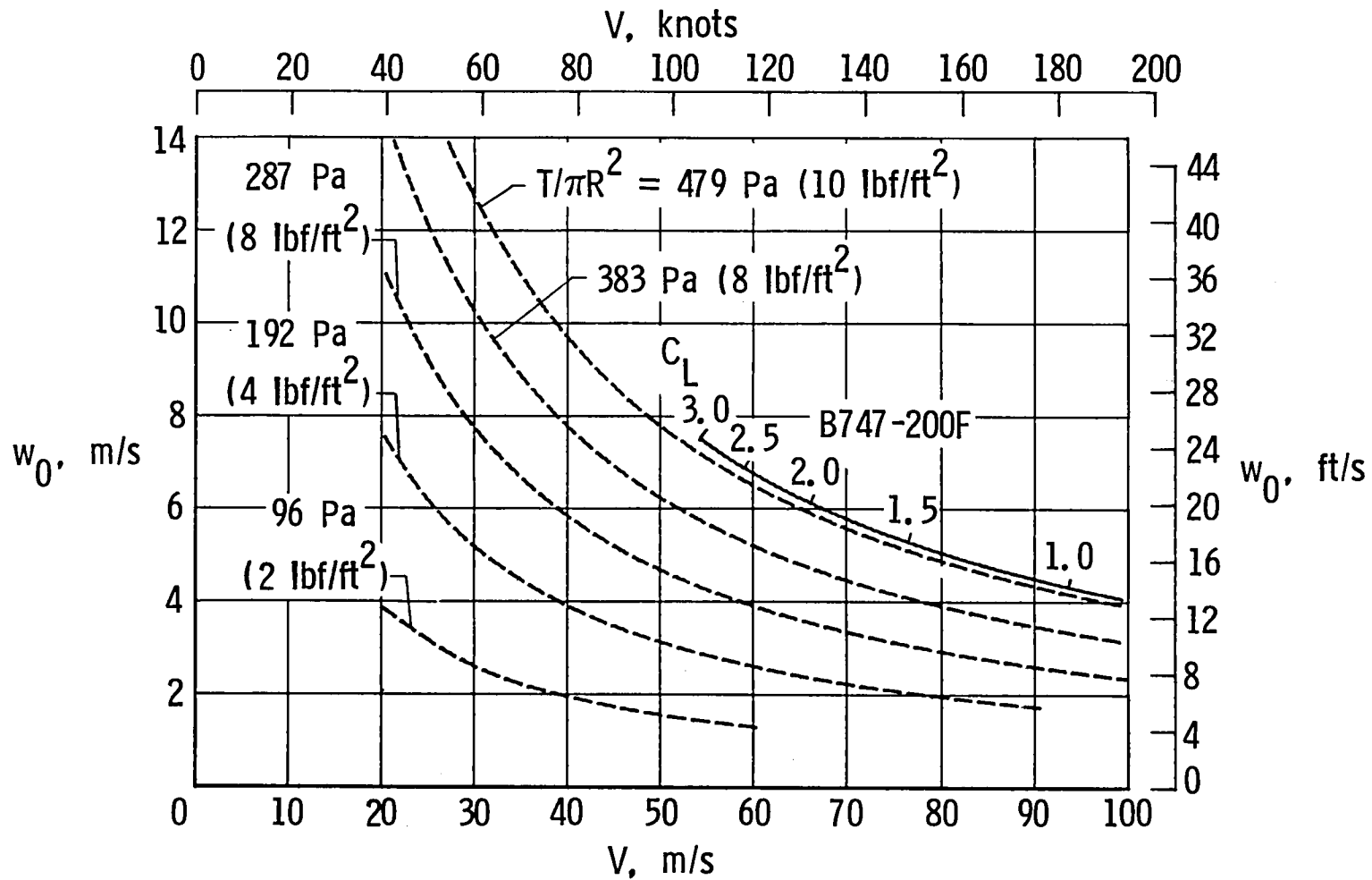

Figure 6.

# ARMY AUTOROTATION ACCIDENT RATES

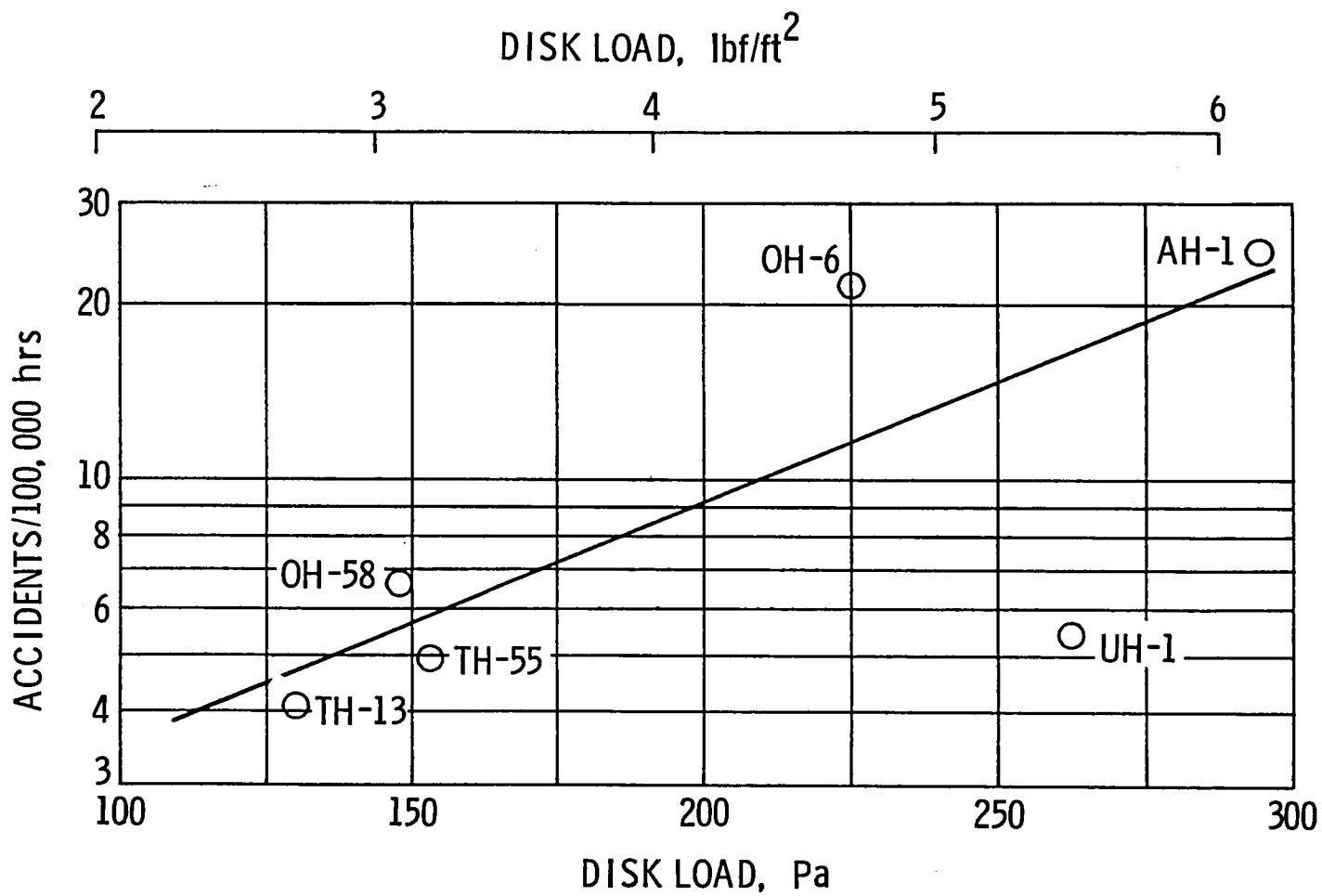

Figure 7.

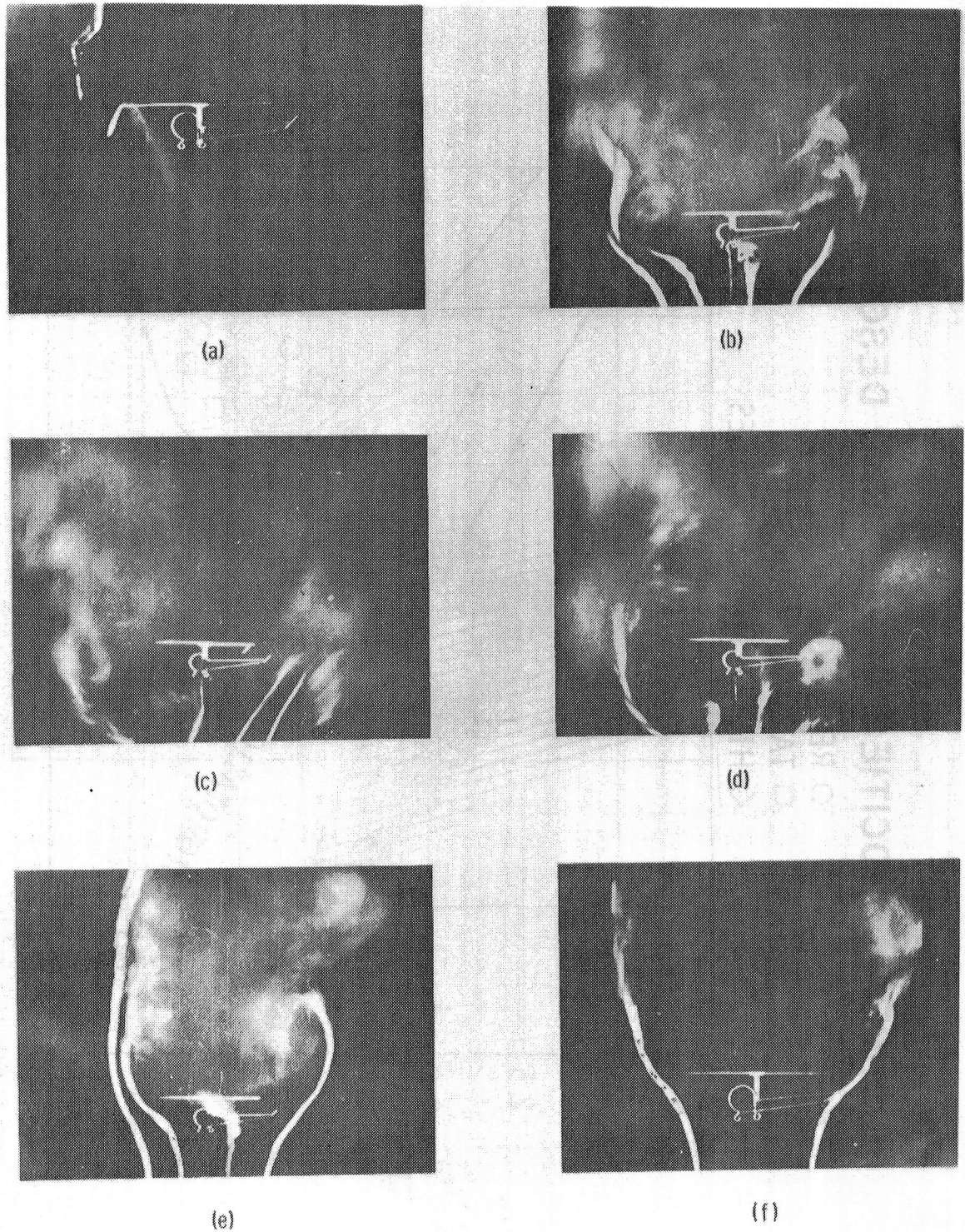

Figure 8. - Flow patterns in vertical descent with the descent rate increasing from (a) to (f). Hovering is shown in (a); the windmill-brake state in (f). (Photographs from reference 6).

# INDUCED VELOCITIES IN VERTICAL DESCENT

- RECTANGULAR BLADES
- TAPERED BLADES
- ◇ HIGHLY TWISTED BLADES

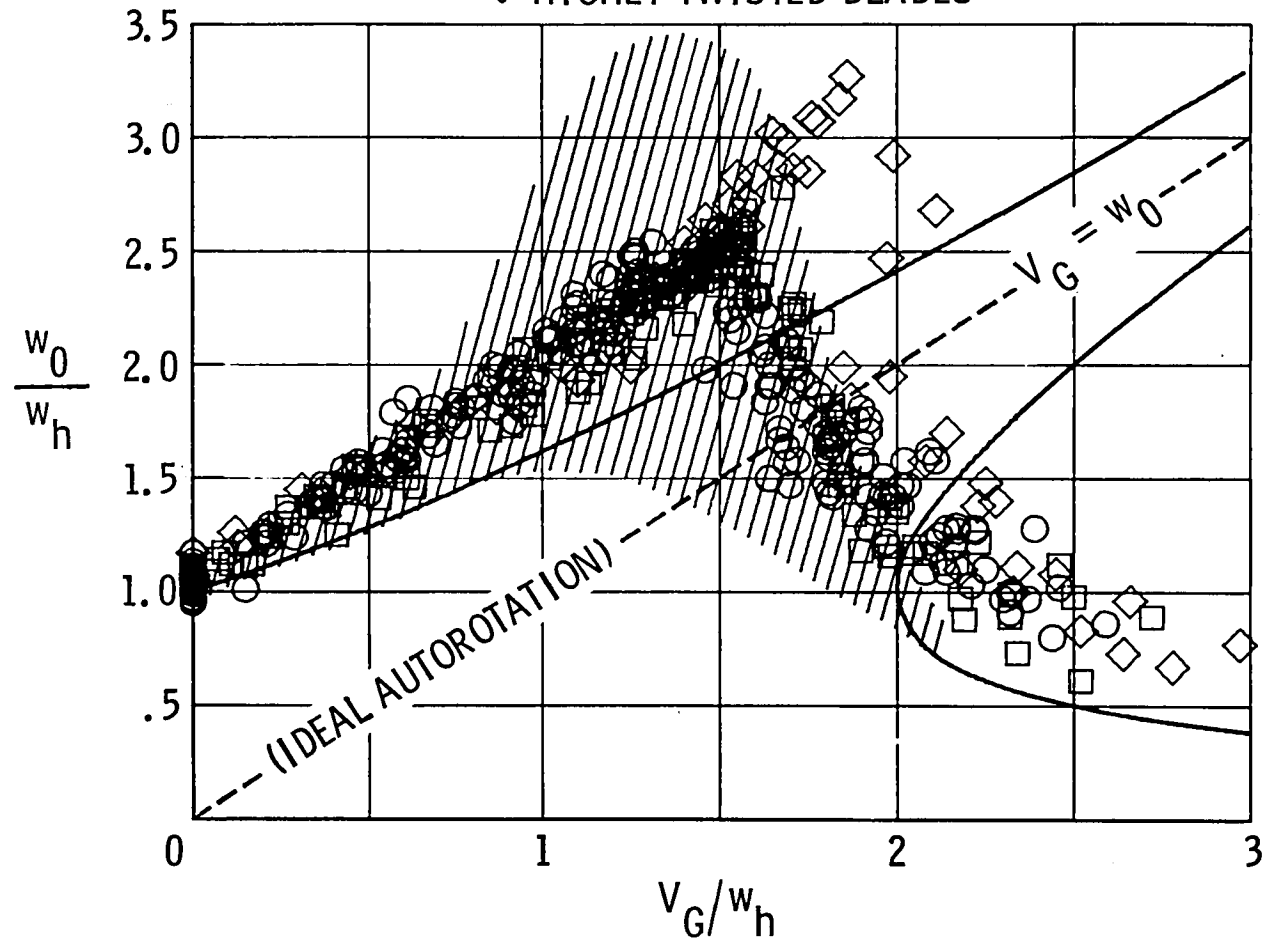

Figure 9.



# POWER FOR VERTICAL DESCENT

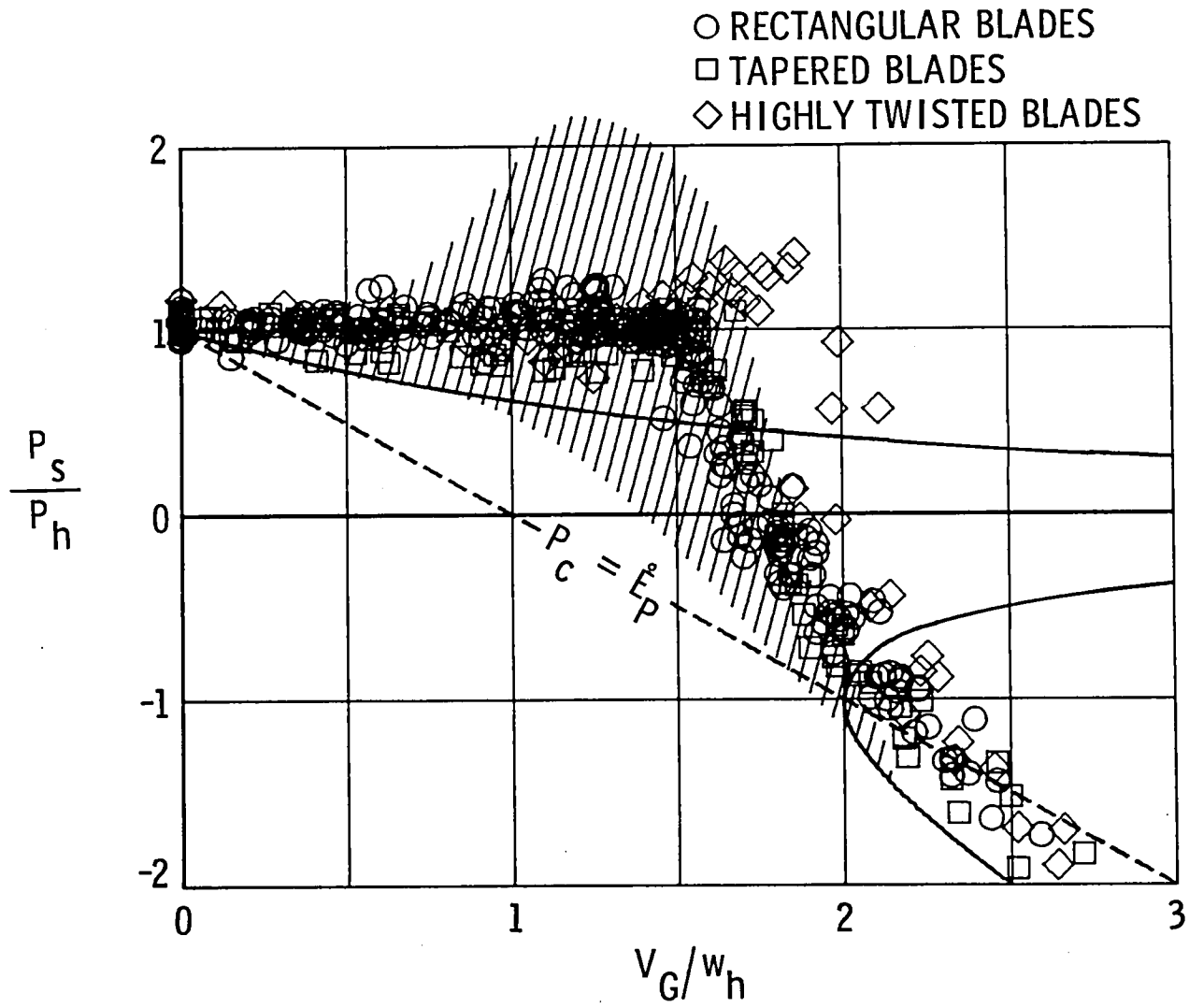

Figure 10.

# POWER FOR INCLINED DESCENT

$$\theta = -10^\circ$$

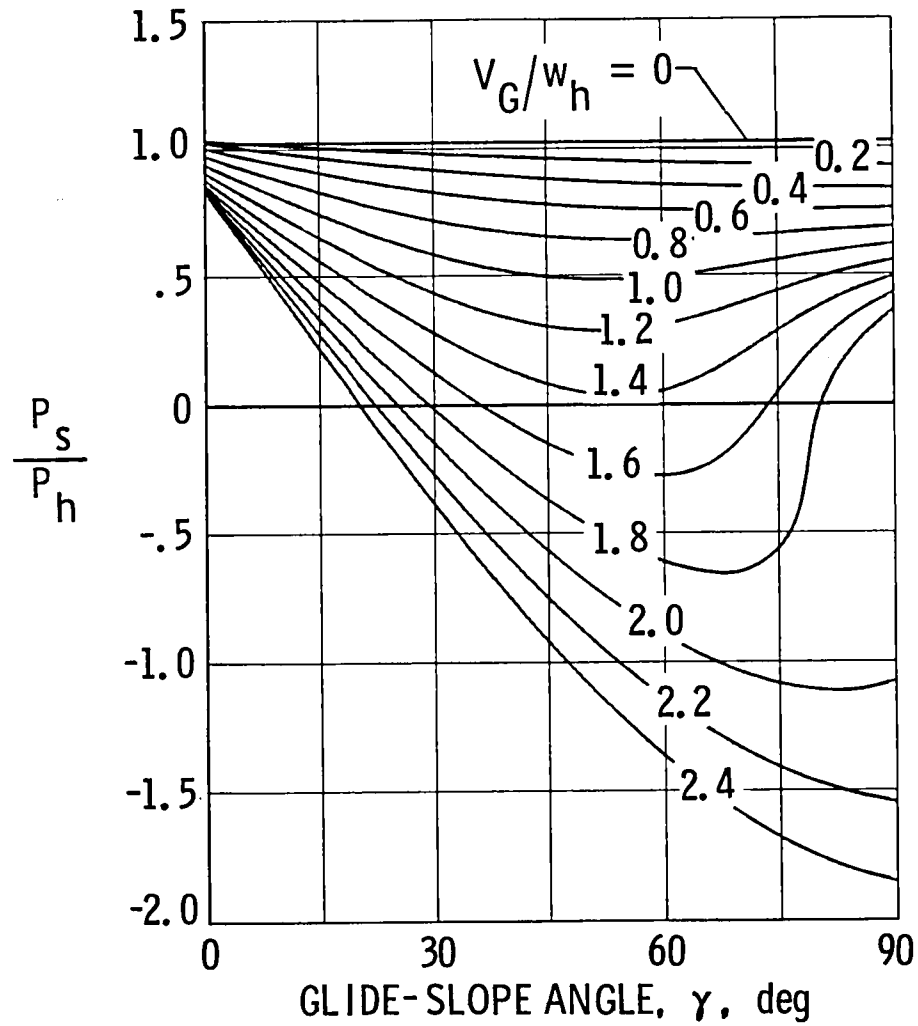

Figure 11(a).

# POWER FOR INCLINED DESCENT

$$\theta = 0^\circ$$

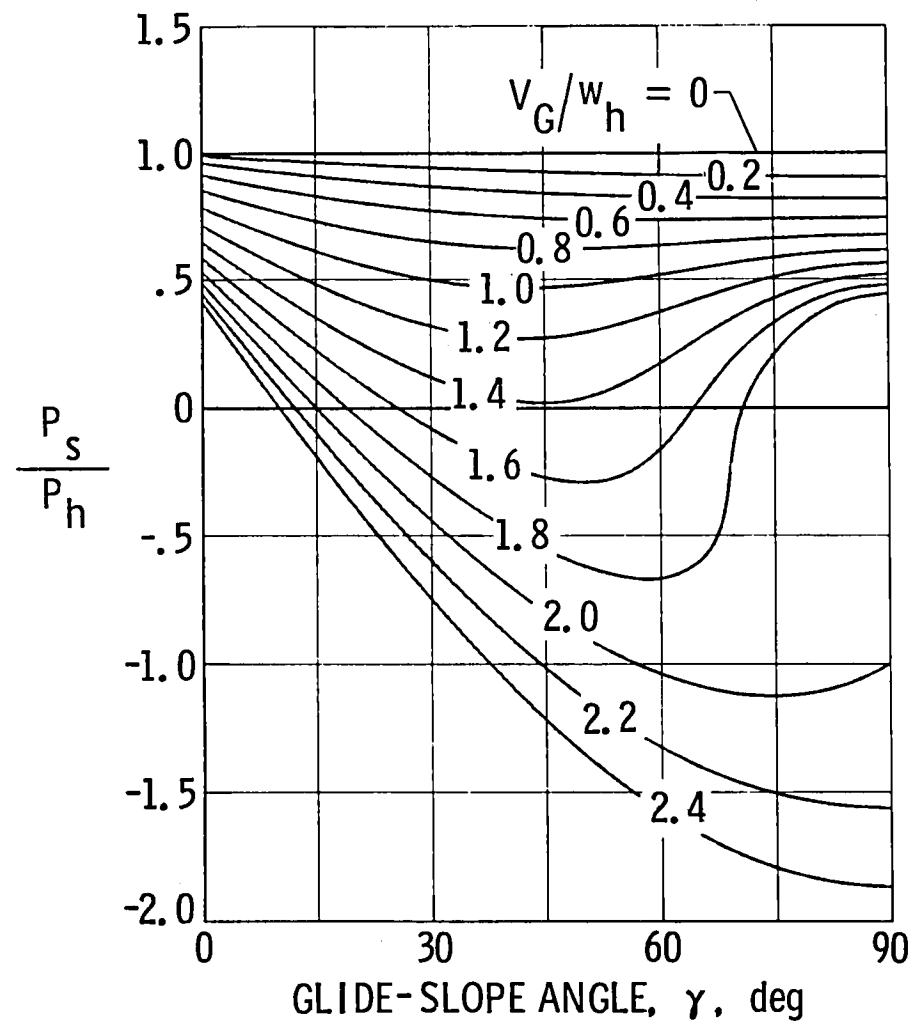

Figure 11(b).

# POWER FOR INCLINED DESCENT

$$\theta = 10^\circ$$

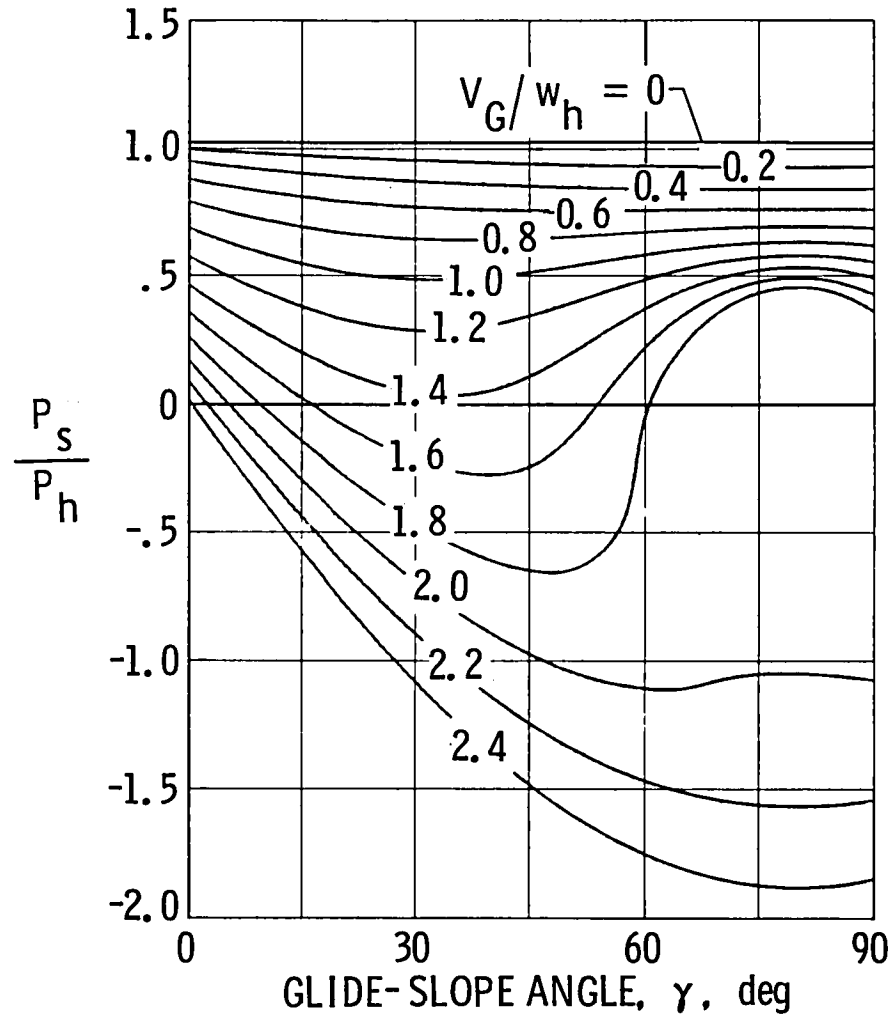

Figure 11(c).

# MINIMUM SPEED OF AUTOGYROS

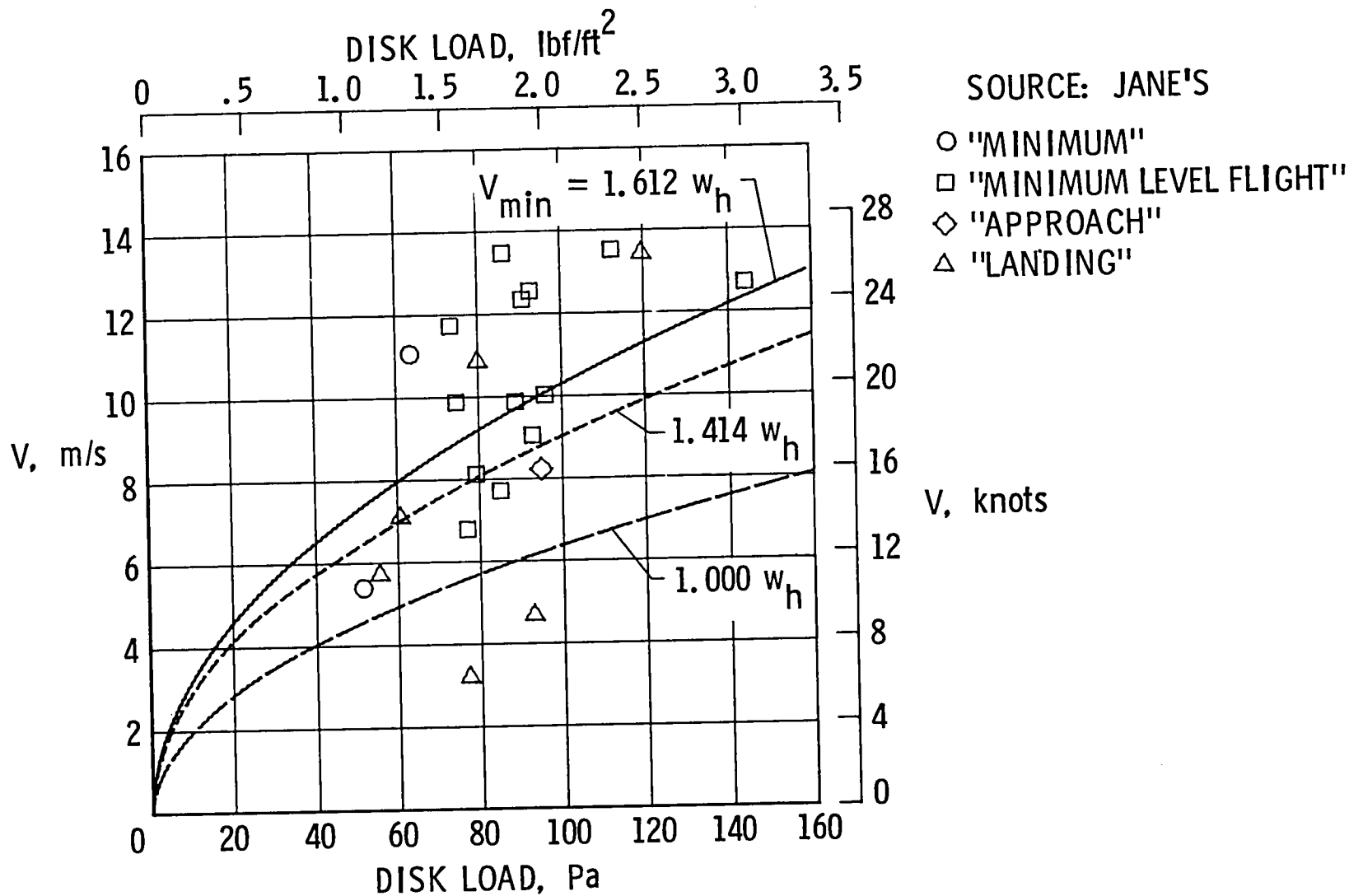

Figure 12.

# HOVERING POWER IN GROUND EFFECT

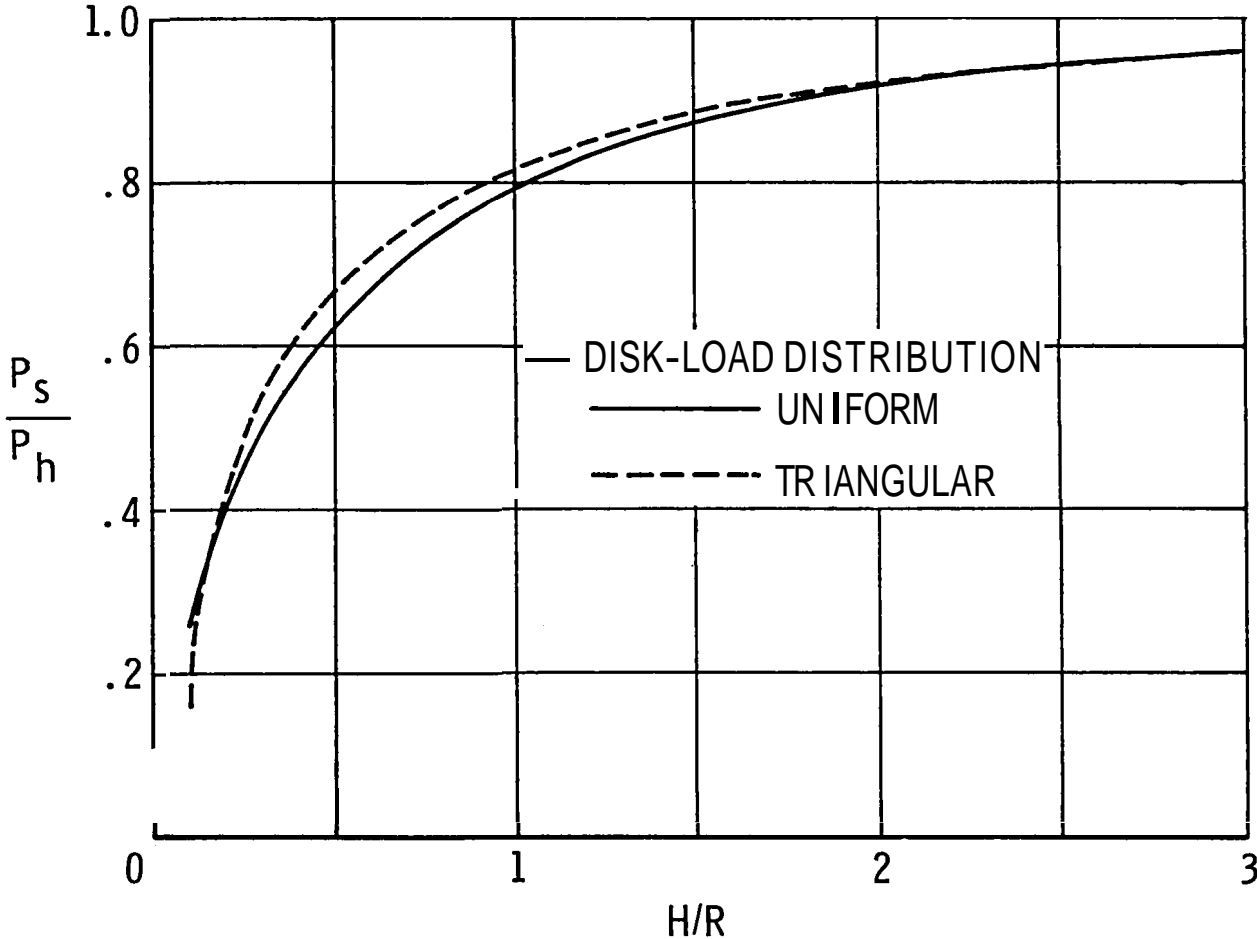

Figure 13.

# VERTICAL INDUCED VELOCITIES HOVERING IN GROUND EFFECT

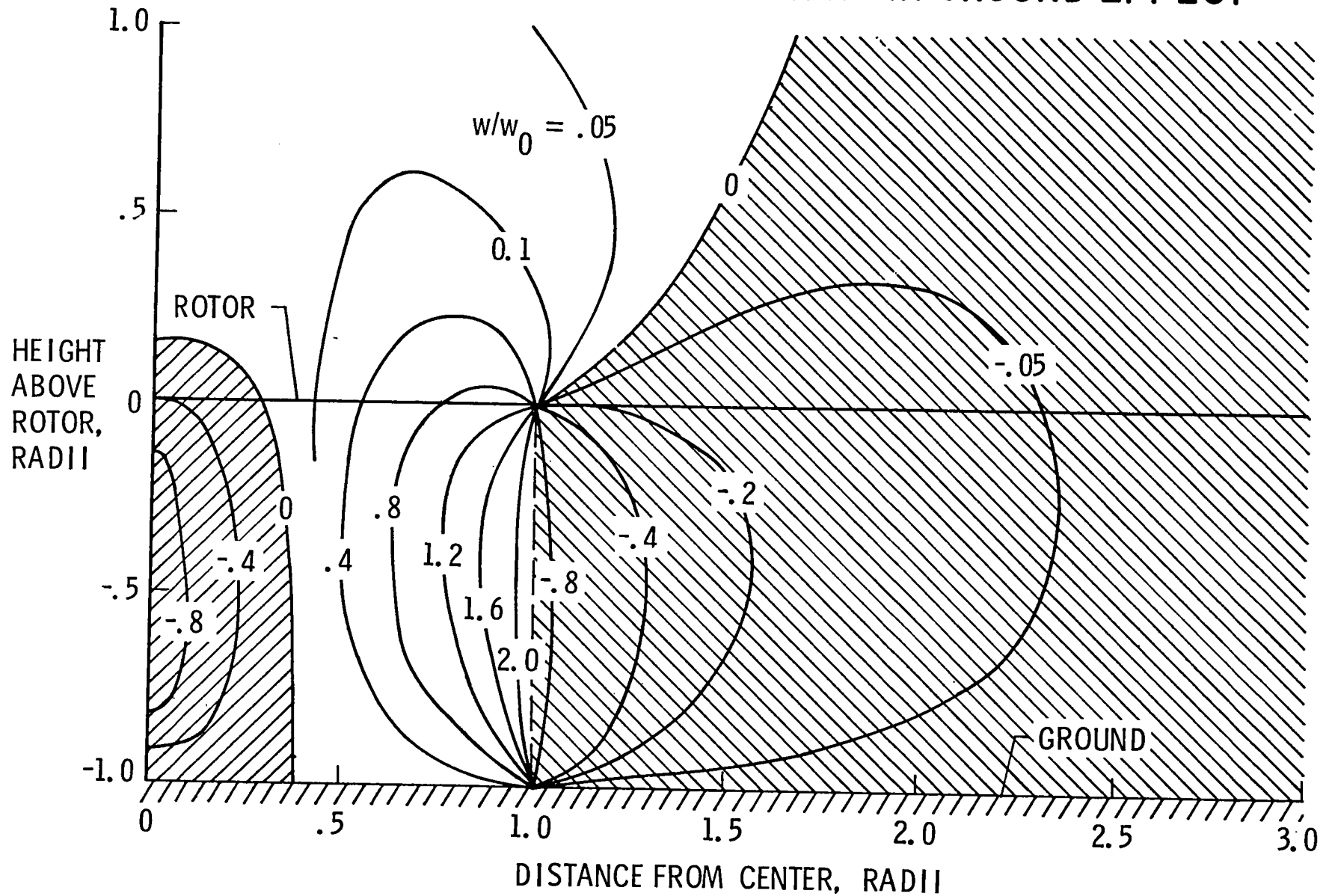

Figure 14.

FLOW IN HOVERING GROUND EFFECT

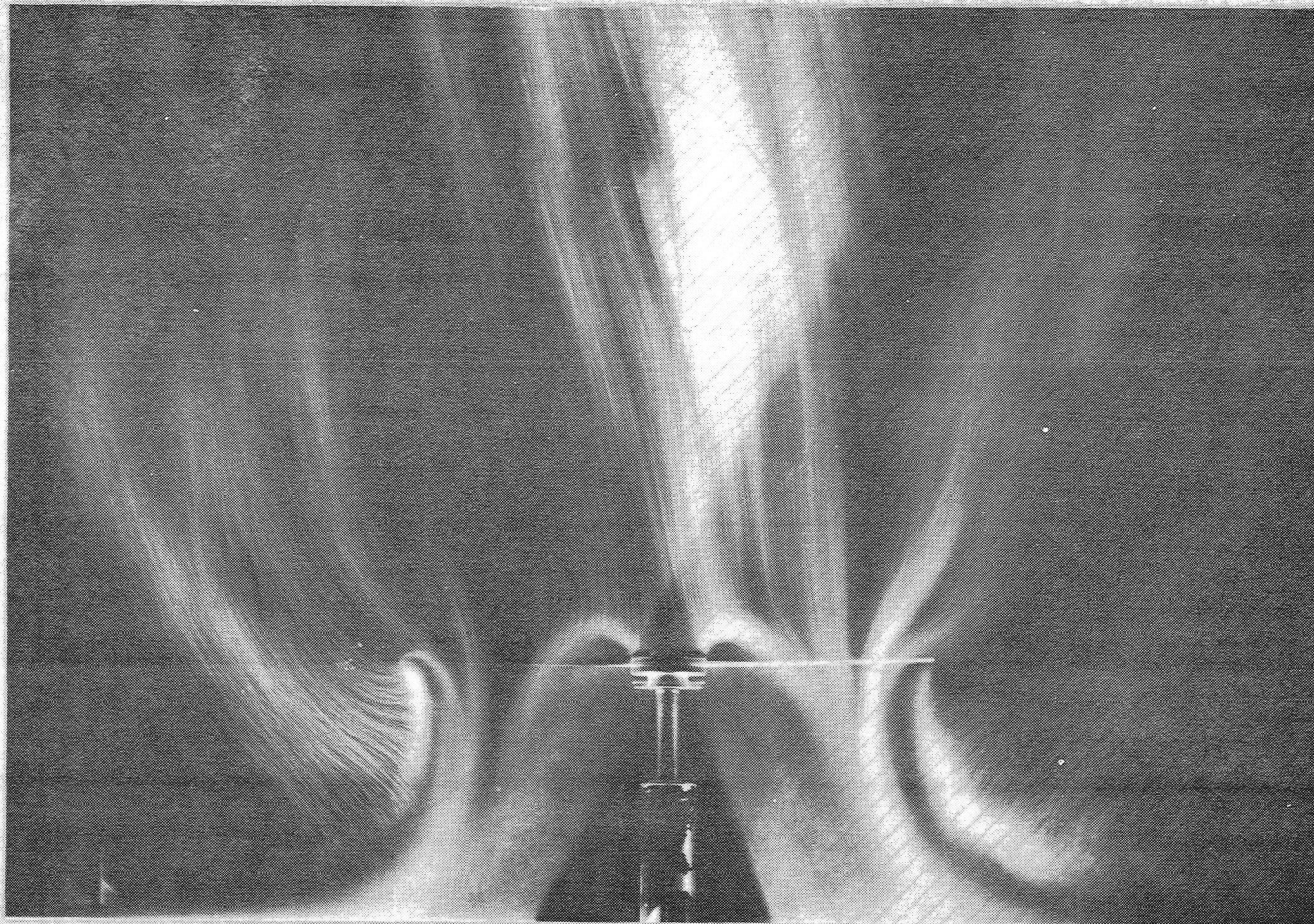

Figure 15.



# POWER IN GROUND EFFECT FORWARD FLIGHT

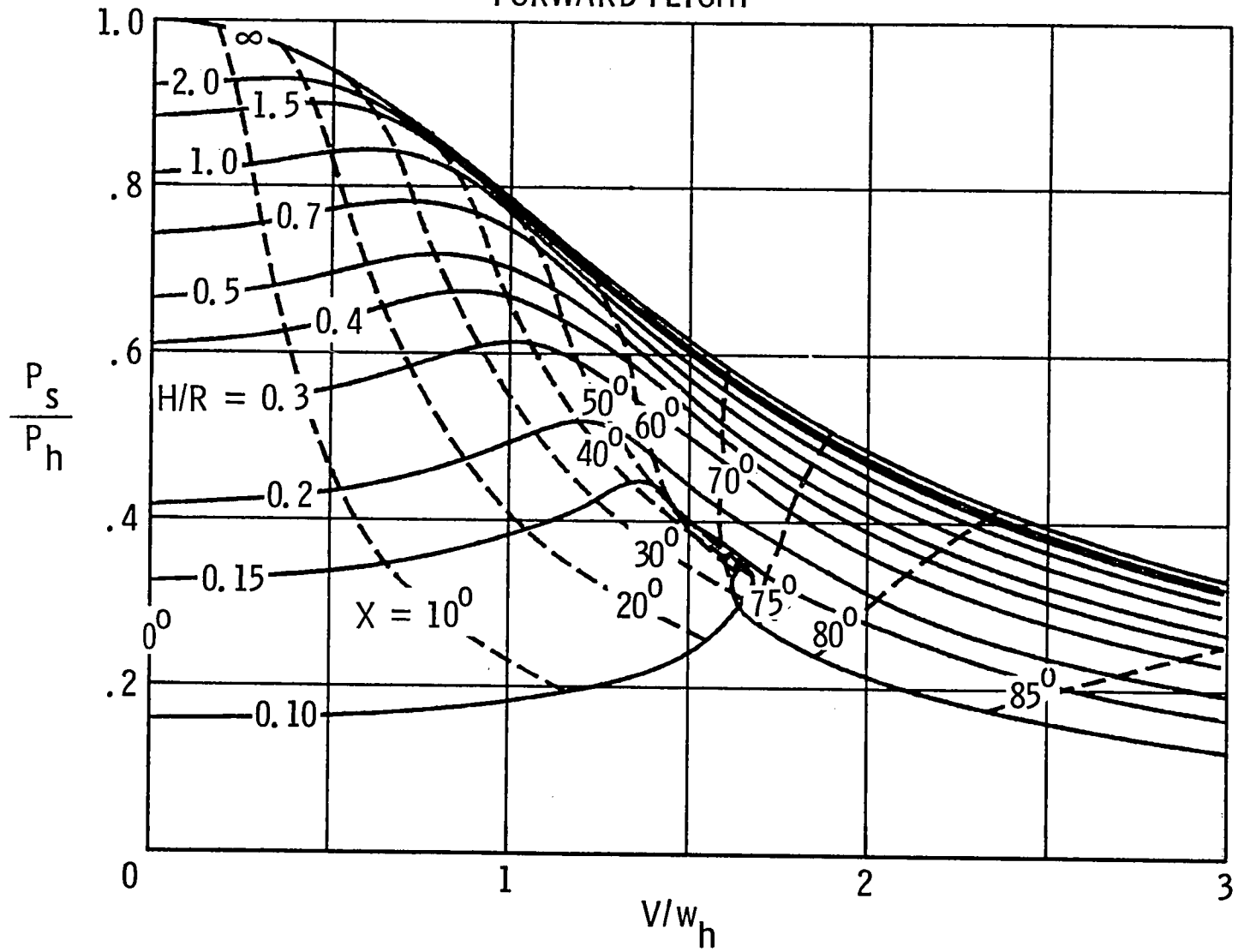

Figure 16.

# POWER IN GROUND EFFECT FORWARD FLIGHT

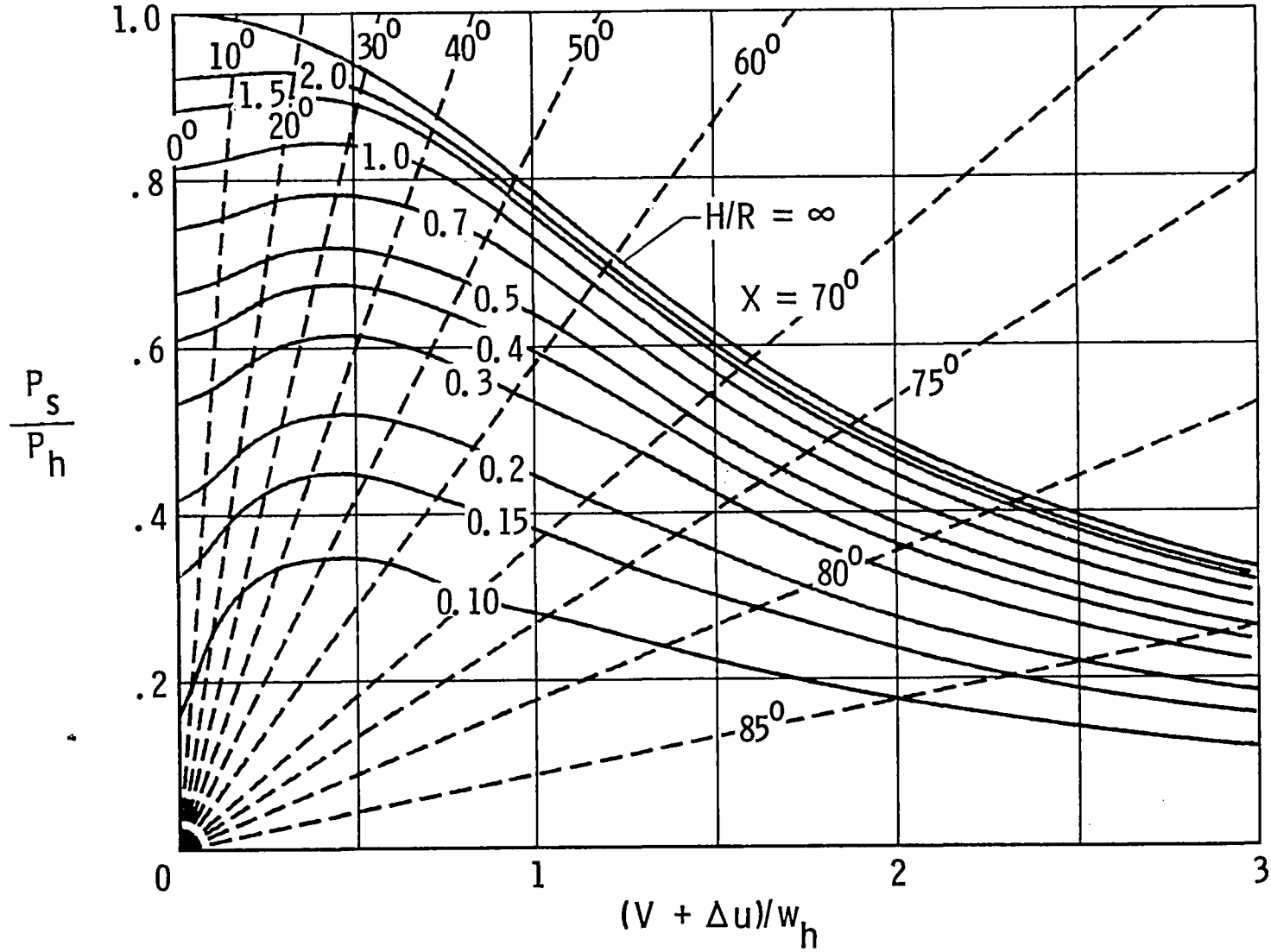

Figure 17.

# POWER IN GROUND EFFECT WHILE FLARED

$\alpha = 20^\circ$

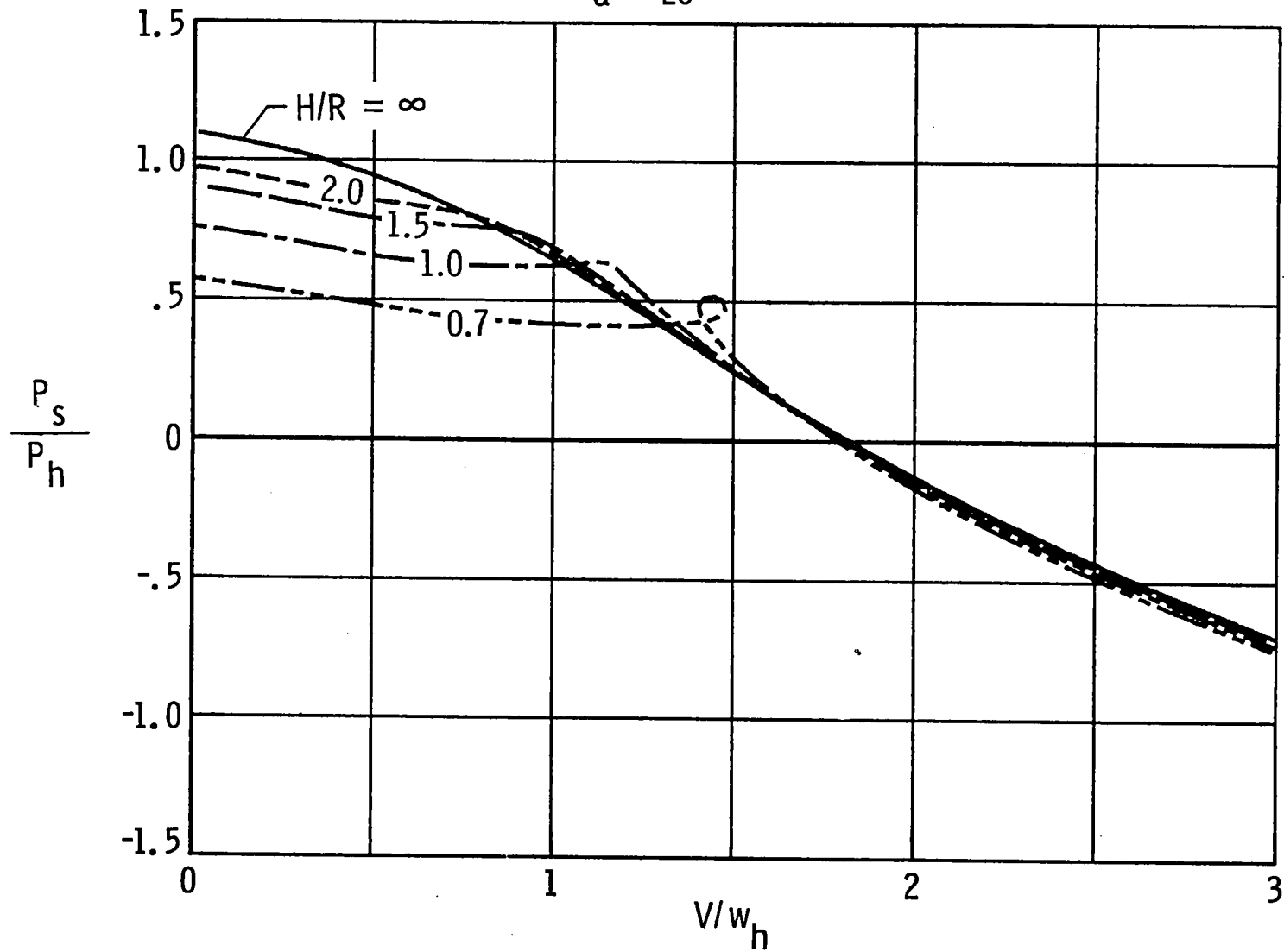

Figure 18.

# POWER IN GROUND EFFECT

## COMPARISON BETWEEN THEORY AND WIND TUNNEL

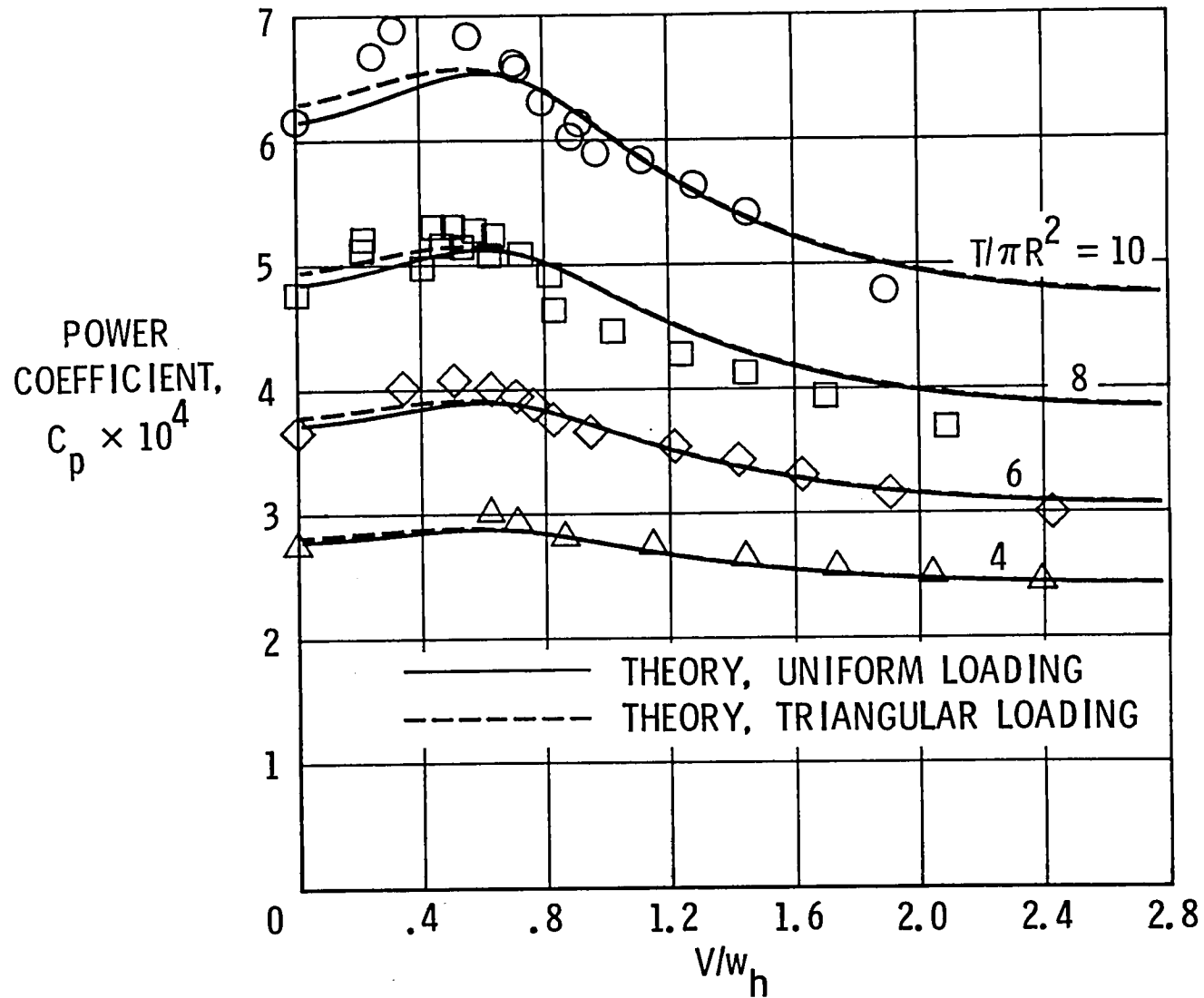

Figure 19.

# FLOW FIELD IN GROUND EFFECT

$$\chi = 70^{\circ}$$

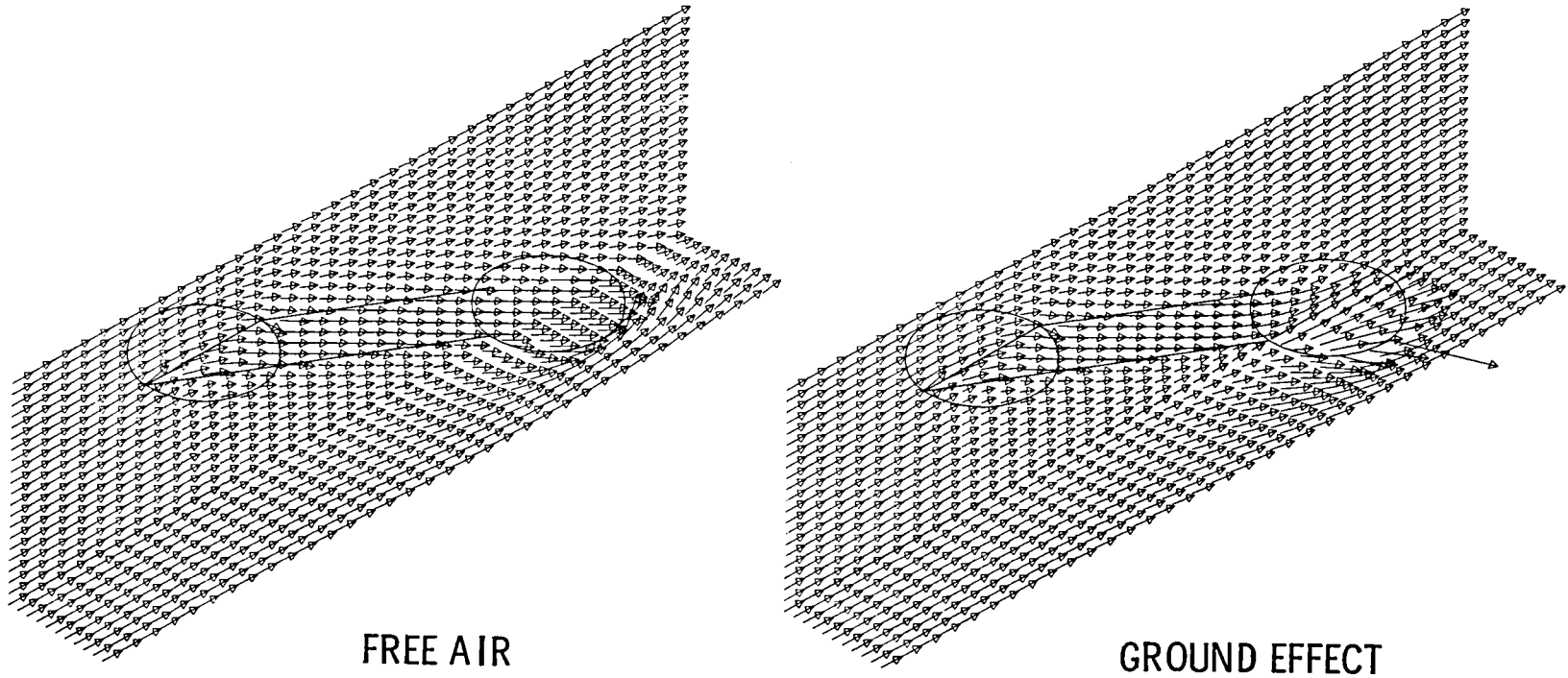

Figure 20.

# FLOW FIELD IN GROUND EFFECT

$$\chi = 60^\circ$$

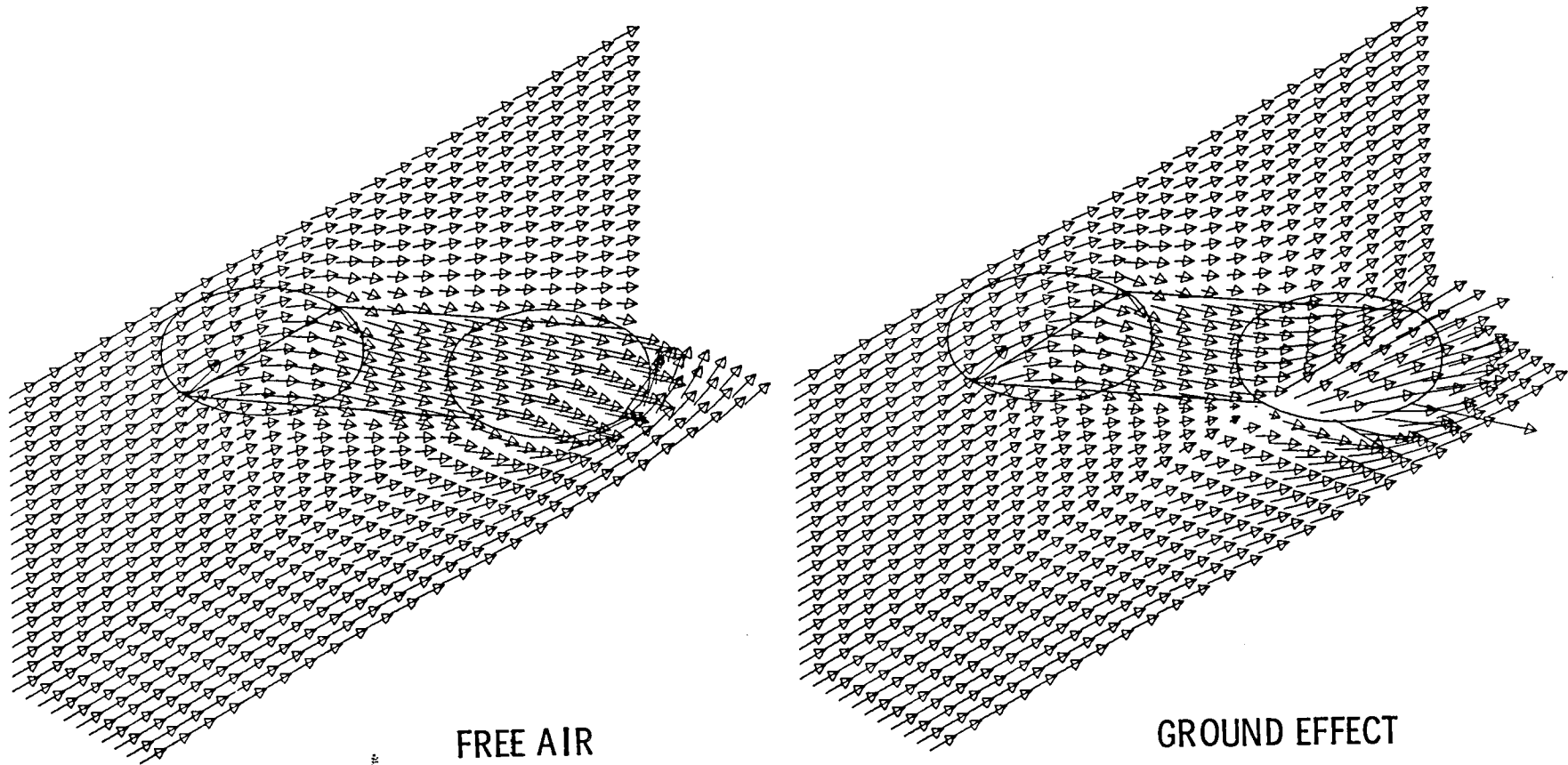
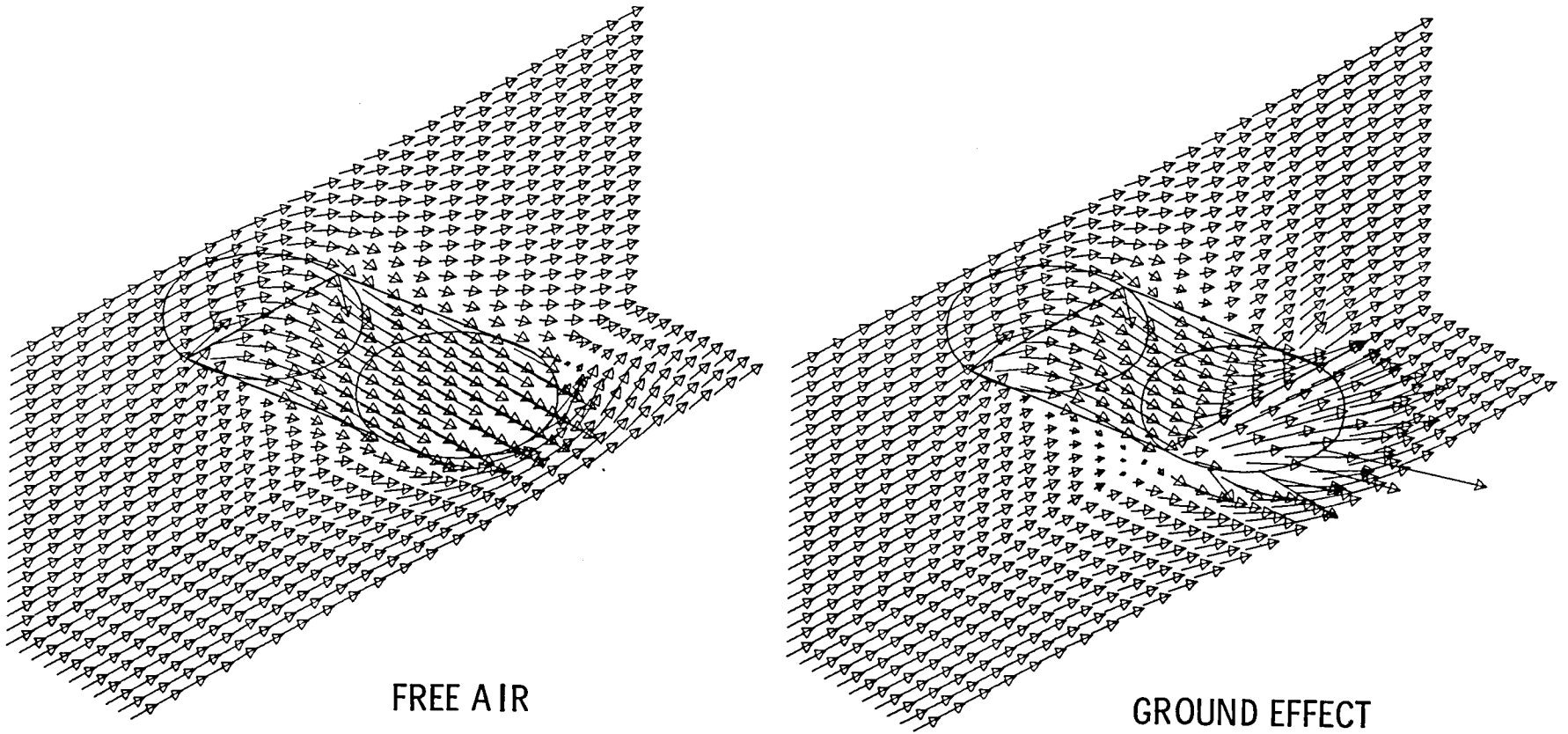

Figure 21.

# FLOW FIELD IN GROUND EFFECT

$$\chi = 50^\circ$$



FREE AIR

GROUND EFFECT

Figure 22.

# FLOW FIELD IN GROUND EFFECT

$$\chi = 40^\circ$$

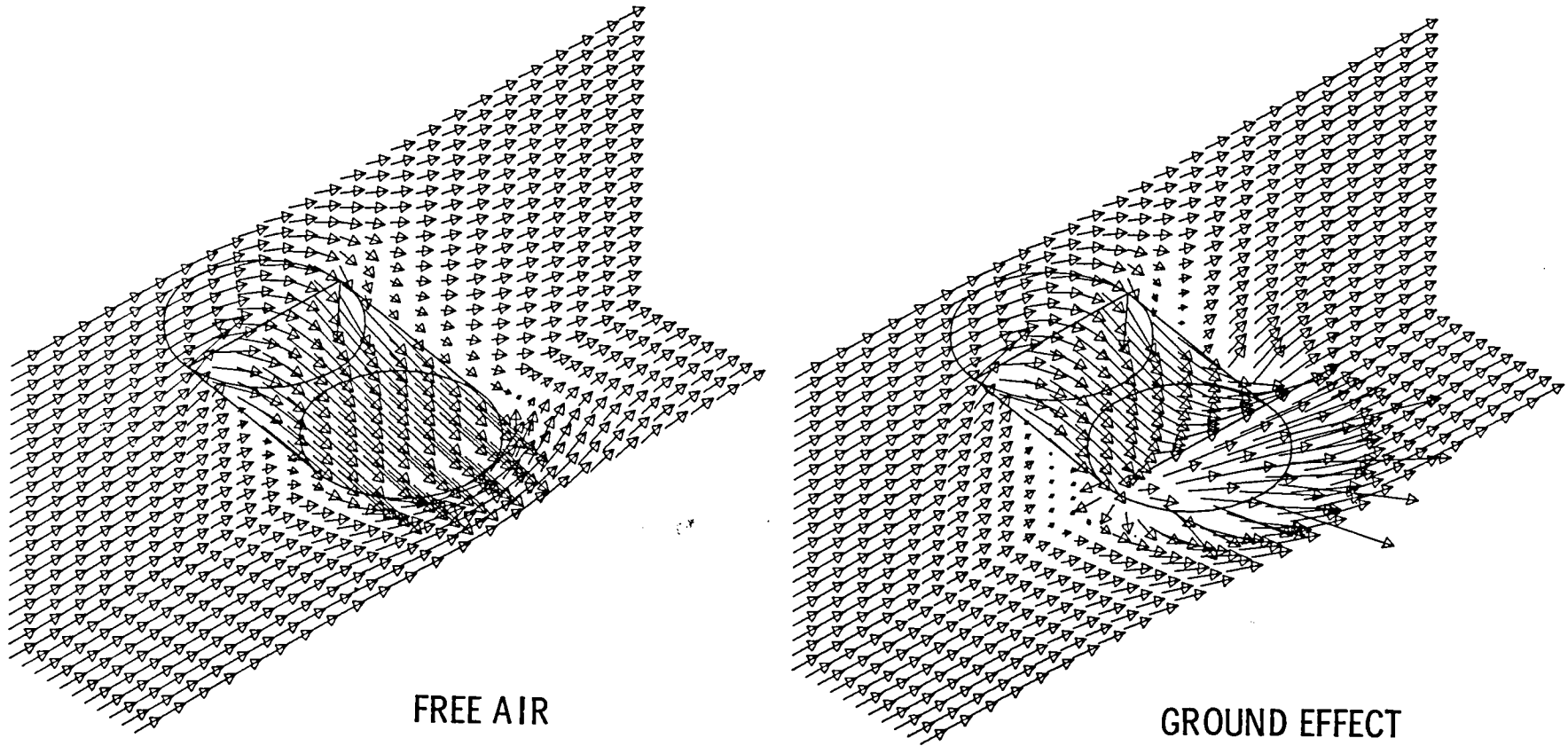

Figure 23.



# FLOW FIELD IN GROUND EFFECT

$$\chi = 30^\circ$$

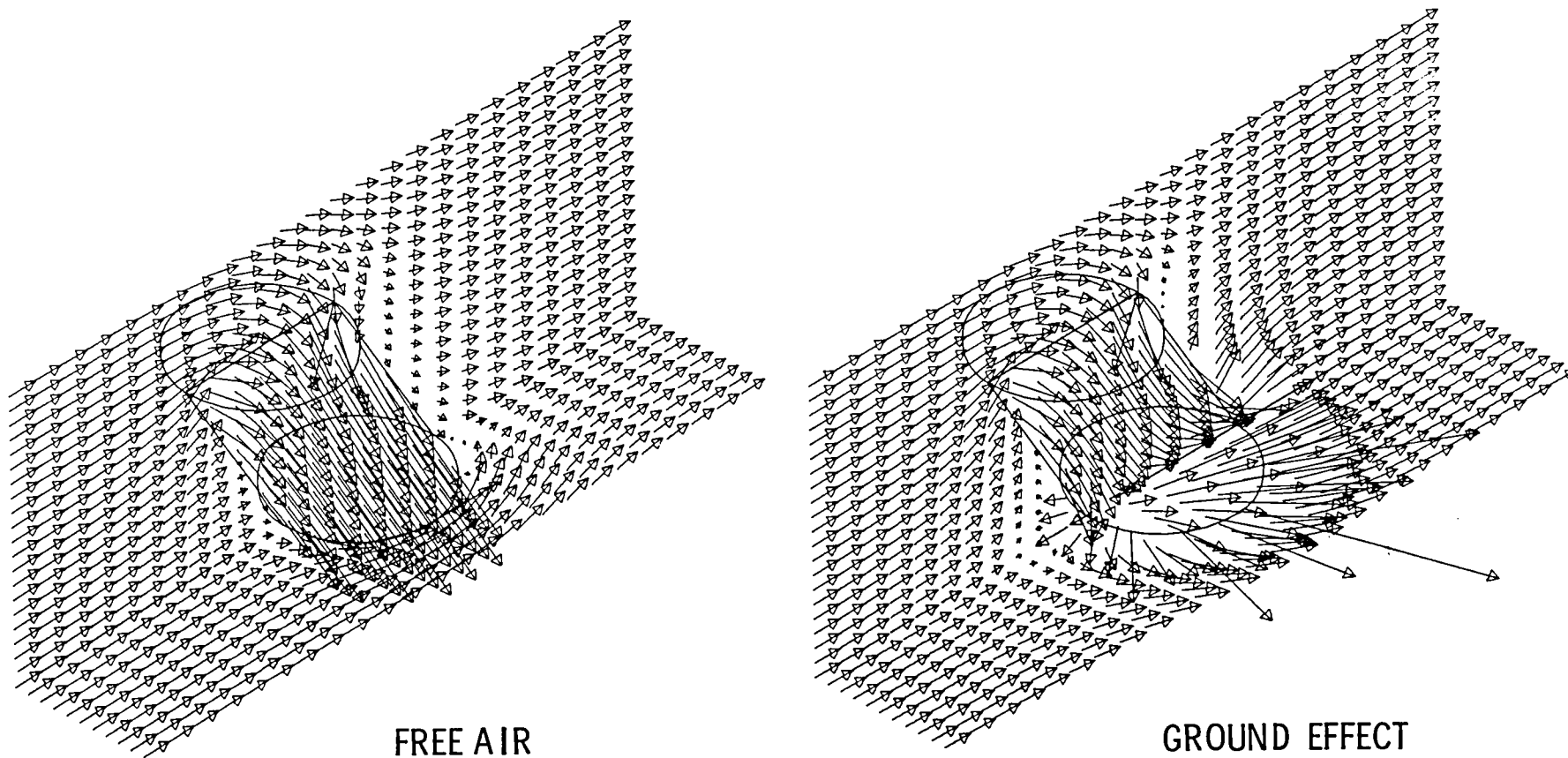

Figure 24.

# FLOW FIELD IN GROUND EFFECT

$$\alpha = 20^\circ$$

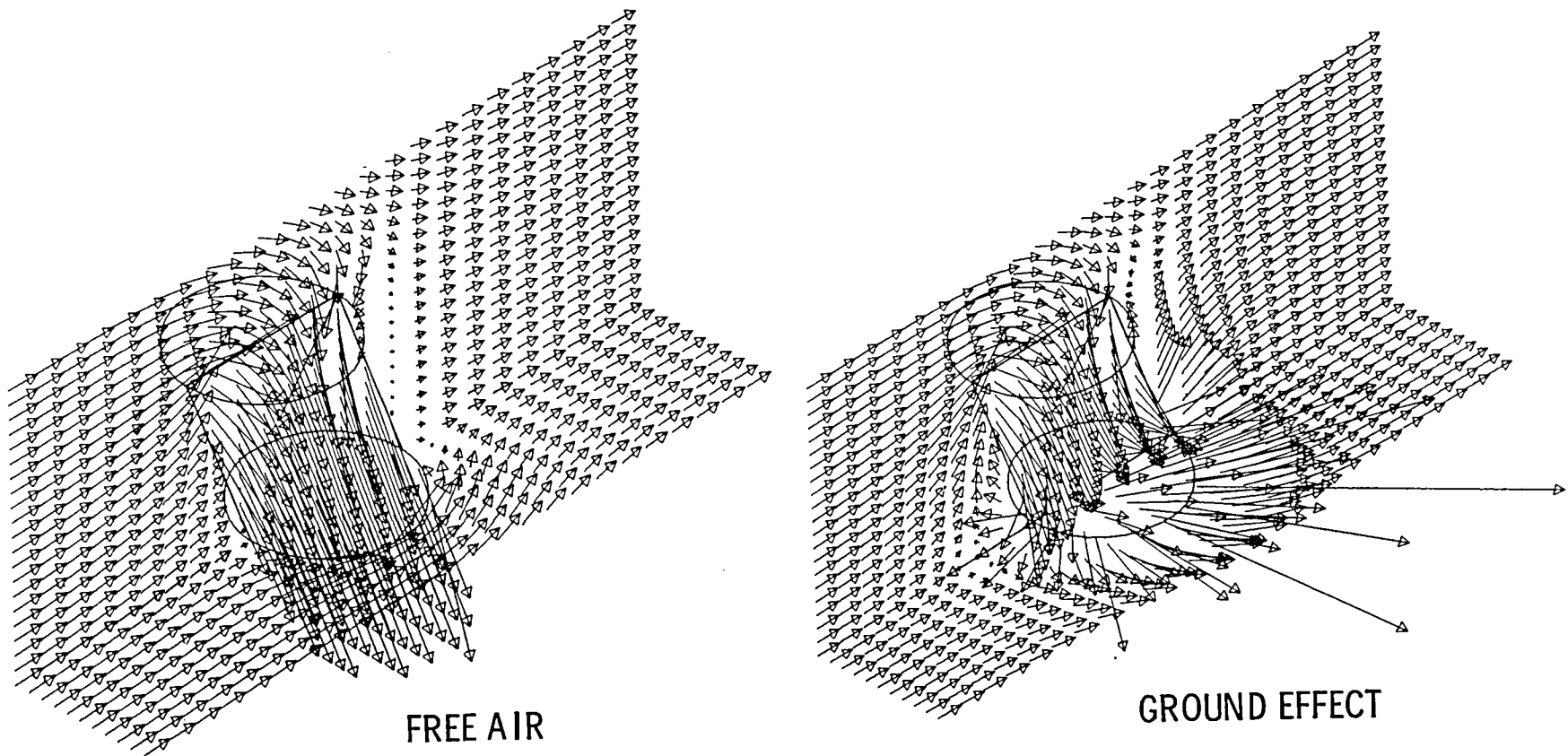

Figure 25.

# FLOW FIELD IN GROUND EFFECT

$$\chi = 10^0$$

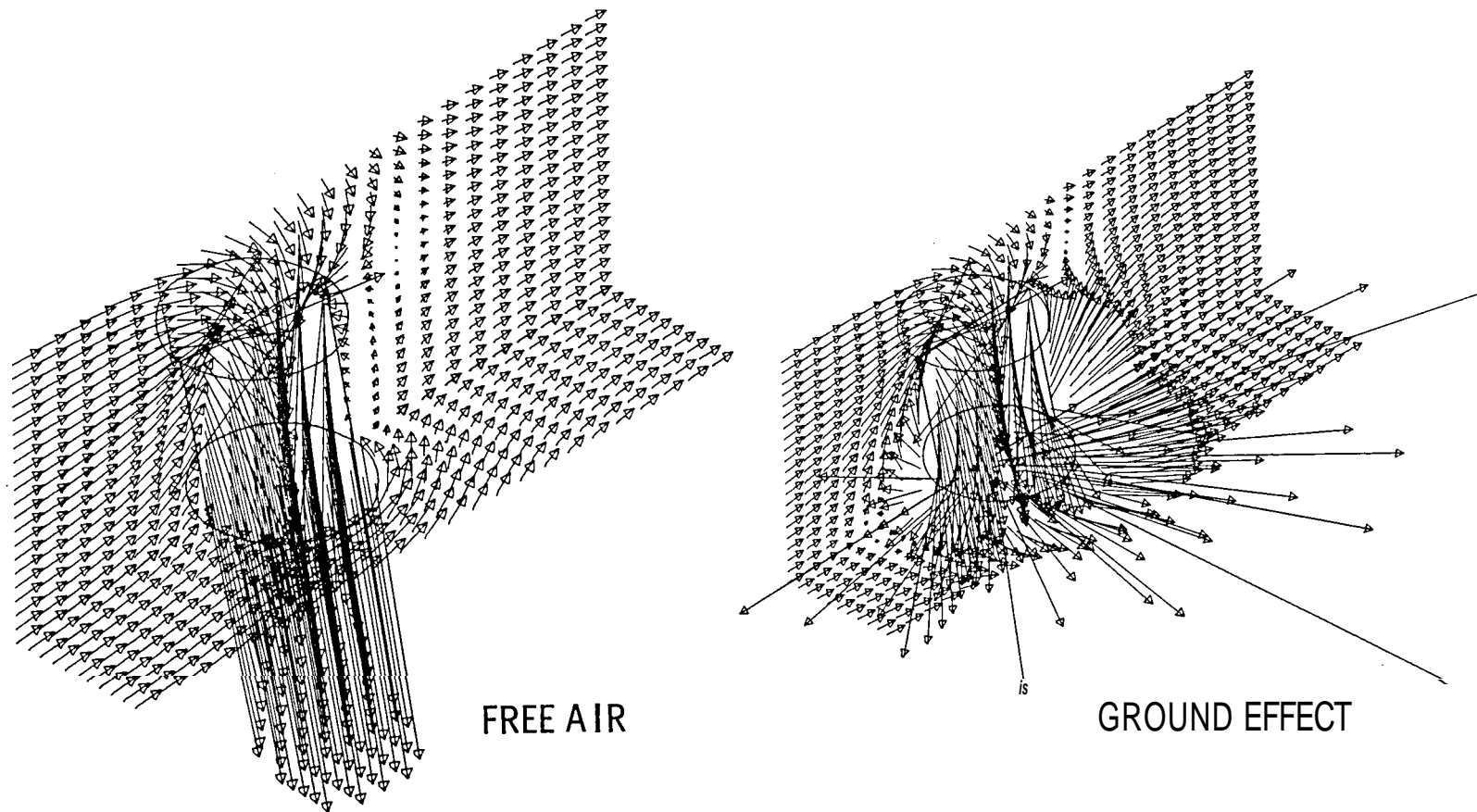
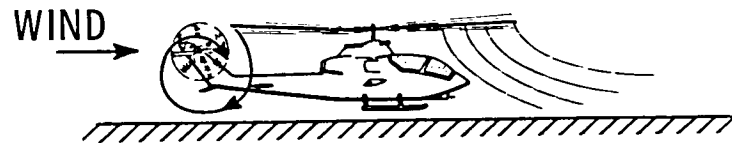
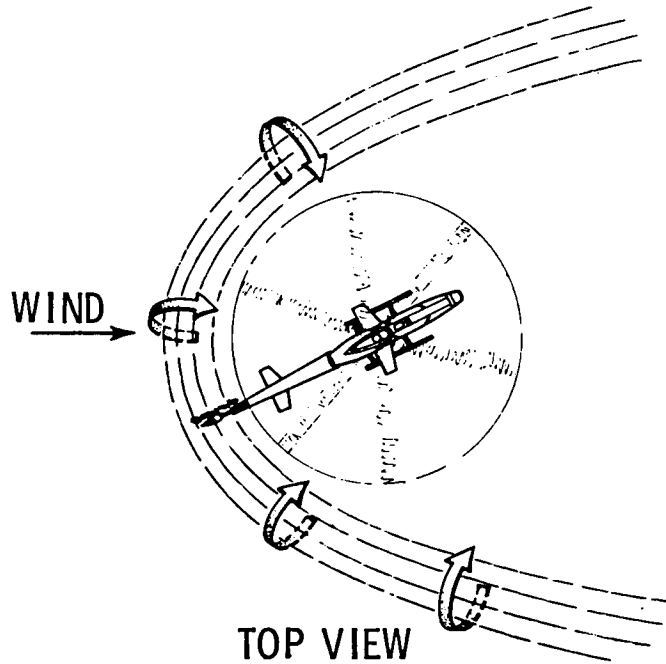

Figure 26.

# DIRECTIONAL CONTROL PROBLEM IN GROUND EFFECT



SIDE VIEW



TOP VIEW

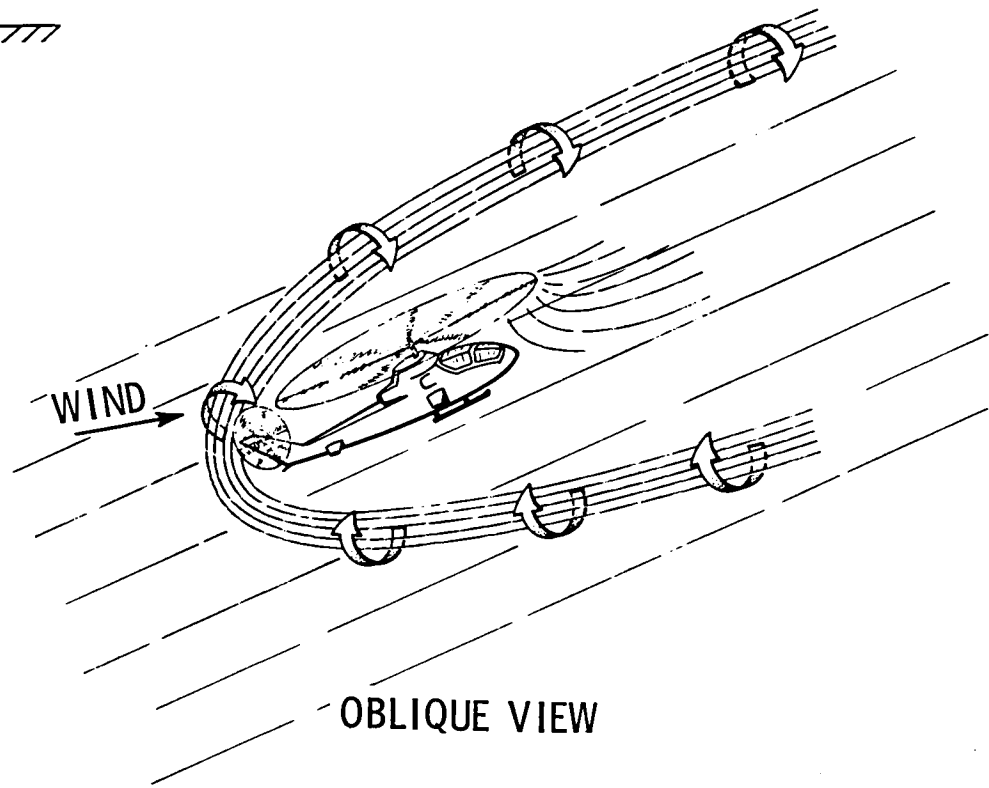

OBLIQUE VIEW

Figure 27.

# GROUND INDUCED INTERFERENCE DISTRIBUTION

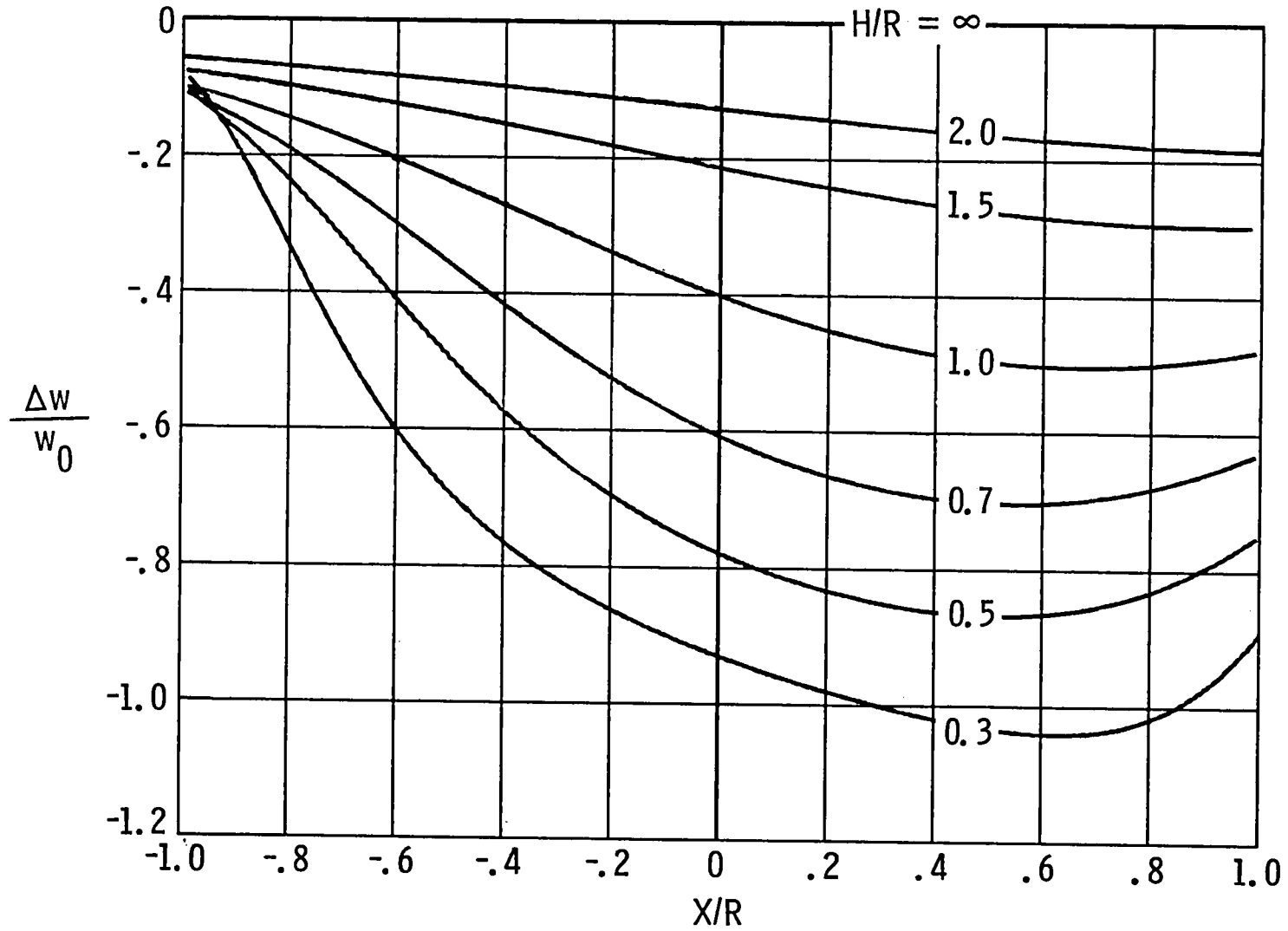

Figure 28.

# EFFECT OF GROUND ON ROLLING MOMENTS

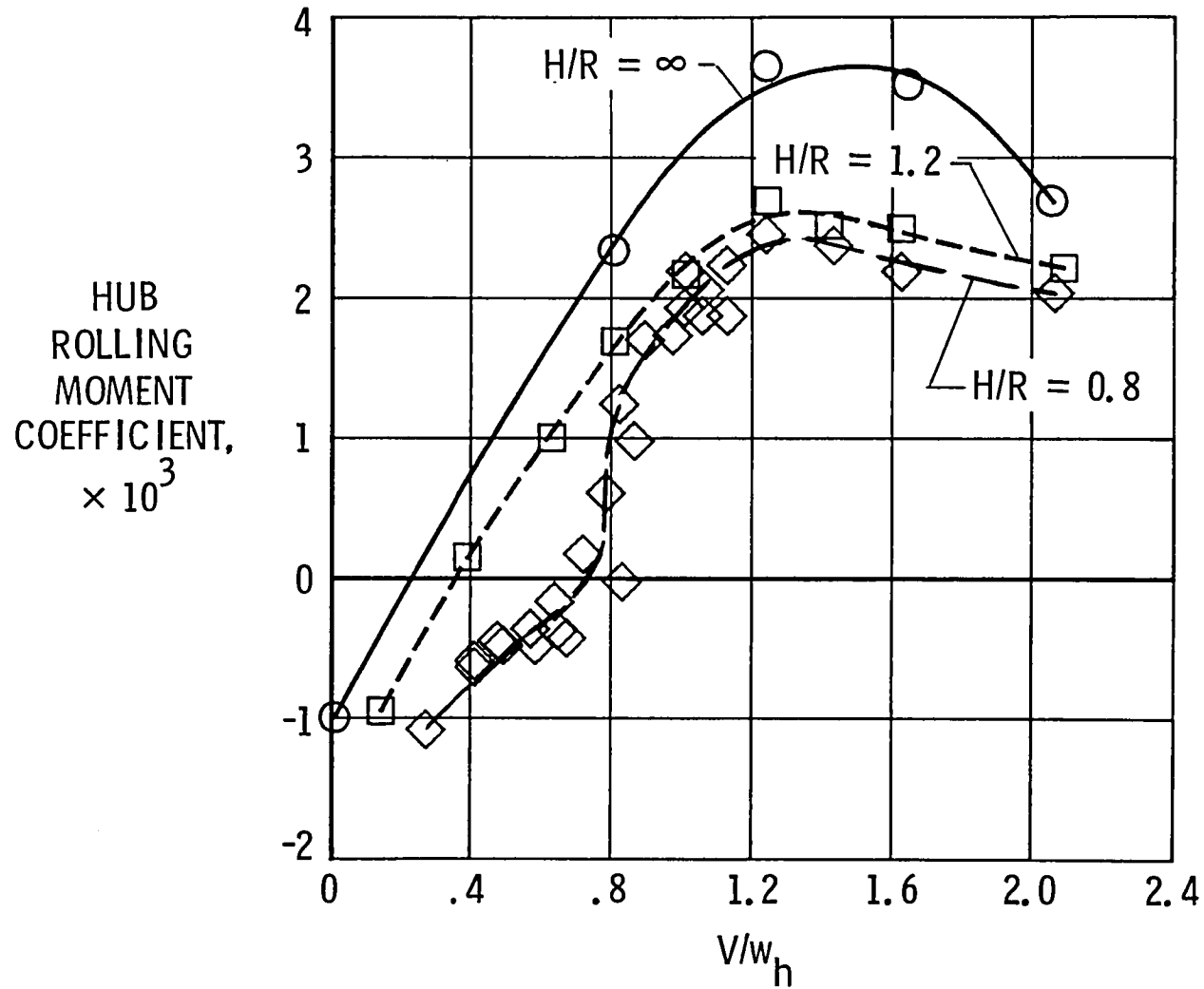

Figure 29.

|   |  |  |  |   |                      |
|---|--|--|--|---|----------------------|
| 1. Report No.<br>NASA TM 80232  |  | 2. Government Accession No.                          |  | 3. Recipient's Catalog No.                                    |                      |
| 4. Title and Subtitle<br>OPERATIONAL IMPLICATIONS OF SOME NACA/NASA<br>ROTARY WING INDUCED VELOCITY STUDIES   |  |  |  | 5. Report Date<br>February 1980                               |                      |
|   |  |  |  | 6. Performing Organization Code                               |                      |
| 7. Author(s)<br>Harry H. Heyson   |  |  |  | 8. Performing Organization Report No.                         |                      |
| 9. Performing Organization Name and Address<br>NASA Langley Research Center<br>Hampton, Virginia 23665  |  |  |  | 10. Work Unit No.<br>530-04-13-01                             |                      |
|   |  |  |  | 11. Contract or Grant No.                                     |                      |
| 12. Sponsoring Agency Name and Address<br>National Aeronautics & Space Administration<br>Washington, DC 20546   |  |  |  | 13. Type of Report and Period Covered<br>Technical Memorandum |                      |
|   |  |  |  | 14. Army Project No.  |                      |
| 15. Supplementary Notes Collateral publication of a paper presented at the Third Midwest Helicopter Safety Seminar, Joliet, IL, February 26-27, 1980. Sponsored by the Illinois Dept. of Transportation Division of Aeronautics in cooperation with the Federal Aviation Administration   |  |  |  |   |                      |
| 16. Abstract<br>Wind-tunnel measurements show that the wake of a rotor, except at near-hovering speeds, is not like that of a propeller. The wake is more like that of a wing except that, because of the slow speeds, the wake velocities may be much greater. The helicopter can produce a wake hazard to following light aircraft that is disproportionately great compared to an equivalent fixed-wing aircraft. This hazard should be recognized by both pilots and airport controllers when operating in congested areas.<br>Even simple momentum theory shows that, in autorotation and partial-power descent, the required power is a complex function of both airspeed and descent angle. The power required may increase violently, rather than decrease, with rate of descent. The nonlinear characteristic, together with an almost total lack of usable instrumentation at low airspeeds, has led to numerous "power-settling" accidents. Simple rules can avoid the regions in which these accidents occur.<br>The same theory shows that there is a minimum forward speed at which a rotor can autorotate. Neglect of, or inadequate appraisal of, this minimum speed has led to numerous accidents.<br>Ground effect is generally counted as a blessing since it allows overloaded takeoffs; however, it also introduces additional operation problems. These problems include premature blade stall in hover, settling in forward transition, shuddering in approach to touchdown, and complications with yaw control. Some of these problems have been treated analytically in an approximate manner and reasonable experiment agreement has been obtained. An awareness of these effects can prepare the user for their appearance and their consequences. |  |  |  |   |                      |
| 17. Key Words (Suggested by Author(s))<br>Induced velocities<br>Vortex hazard<br>Power settling<br>Ground effect  |  |  | 18. Distribution Statement<br>Unclassified - Unlimited<br><br>STAR Category 02 |   |                      |
| 19. Security Classif. (of this report)<br>Unclassified  |  | 20. Security Classif. (of this page)<br>Unclassified |  | 21. No. of Pages<br>52  | 22. Price*<br>\$5.25 |

