

THE EXXON RECHARGEABLE CELLS

P. Malachsky
Exxon

The Battery Division of Exxon Enterprises was formed about 2 years ago with the goal of commercializing an ambient temperature look in secondary cell technology based on the titanium disulfide cathode.

What I am going to talk about this afternoon is some of the basic elements of the cell design and discuss some of the performance of the two very limited performance button cell products which have been developed. These limited performance products were developed for micro-electronic applications which require low drain rate and do not require very many deep cycles as typically encountered in solar rechargeable watches and clocks.

(Figure 2-93)

The first vugraph shows the typical requirements for a solar rechargeable watch. Your average discharge rate is on the order of 2 to 3 microamperes. This requires about 20 milliampere-hours per year of watch operation. To maximize the charge acceptance when the solar watch will be in the presence of sunlight, you have to have fairly good charge rate acceptance in the vicinity of 1 to 2 milliamperes.

A very important factor, particularly for analog quartz watches, is that the cell impedance should stay below 100 ohms. Otherwise, the voltage of the watch module will cause the watch to stop operating.

(Figure 2-94)

The next vugraph shows some of the characteristics of the two cell sizes which were developed: the LTS 90 and the LTS 25. The LTS 90 was made to be a technology sampler, although it does have some potential applications in solar rechargeable clocks. The LTS 25 was specifically designed for watch operation. The LTS 25 is essentially a small version of the LTS 90. They both have the same overall cell heights. We have used in these cells a lithium aluminum anode. This was to get around some of the problems that Gerhart has mentioned of the reactivity of lithium with the electrolyte and to try to bring the voltage of the battery as close to 1.5 volts to make the watchmakers happy. So the voltage range of the cells is on discharge between 2 volts and 1.4 volts.

The cell capacity of the LTS 90 is about 90 milliampere-hours, the LTS 25 about 25 milliampere-hours. This calculates to volume densities of about 1.8 hours per cubic inch. The cell impedances are 7 ohms and 25 ohms, roughly proportionate to the area difference. Cell discharge rates which I will talk about later are less than 10 percent per year.

(Figure 2-95)

This vugraph shows the basic button cell assembly. The cells are hermetically sealed, and they have a projection weld with a glass-to-metal seal. The TIS to cathode is just a cold-pressed cathode that runs at about 7 percent porosity. This high-cathode porosity lets the cells be filled rather rapidly so that they can be made in fairly large-volume production.

A two-layer separator system is used with an absorber, a microporous separator, and the anode; the lithium aluminum anode is formed by making a randomate of lithium foil, aluminum foil, and electrolytic action after the cell is closed. The lithium aluminum anode is formed *in situ*.

(Figure 2-96)

The next vugraph shows a typical discharge and charge curve behavior of the LTS 90. You have a typical sloping voltage of a titanium disulfide cell. This has an advantage to some people that can be used as a measurement of the state of charge of the battery.

On charging the cell, however, the cell behaves more like a lithium titanium disulfide cell because at these charge rates you are not letting your lithium equilibrate with the aluminum so that the cell behaves very much like a lithium cell in charge. But, you then have as much of a possibility of dendrite formation because you are using the alloy.

(Figure 2-97)

The next figure shows the deep discharge performance of the watch-size cell. The cells are typically tested in accelerated testing at the C/100 rate on discharge and at the C/50 rate on charge. On these deep type of discharges, you see a fading capacity from initial value of around 23-milliampere values at the accelerated test rate down to maybe around half that rate, the value after seven deep cycles.

The main reason for this degradation in capacity of the cell is that your lithium aluminum alloy anode is mechanically unstable under these deep discharge conditions.

(Figure 2-98)

The next figure shows, however, what happens when you subject these cells to shallow depth discharges rather than deep depth. What we are comparing is the rise in cell impedance as we cycle the cells in terms of dicumulative capacity.

The shallow depth discharge conditions are done under the conditions of 1-milliampere discharge and 1/2 milliampere charge to a capacity of 1 milliampere-hour. You can see there is a big difference in the rate of impedance growth between deep discharge and shallow depth discharge. In terms of the shallow depth this is essentially the number of discharge cycles that the cells have been put through.

(Figure 2-99)

The next vugraph shows some idea of what the cell can do after being subjected to these rather shallow discharge conditions.

This shows some data for the LTS 25. The cell had initial impedance of about 24 ohms. It was given at 25 percent depth of discharge to 6 milliampere-hours. Then, it was put through the shallow cycle at 5-percent depth of discharge for essentially 211 cycles.

During this time the cell impedance rose to about 60 ohms. It was then given three deep discharges. You can see that there is still appreciable capacity now in these cells after these extended shallow cycles, and the cell impedance is still below 300 ohms maximum.

(Figure 2-100)

Turning now to look at the storage capability of these cells, we initially began looking at one month's storage at 65 degrees as simulating 1 year in ambient temperature, relating down to 3 months at 65 degrees.

This shows some storage capability for the LTS 90. This is the 1-inch diameter cell. The initial cell impedances – this is for an average of five cells – is about 5 ohms. After 3 months at 65 degrees, there is a barely detectable rise in the cell impedance.

The first discharge is essentially equal to a fresh cell, 95 ± 5 milliampere-hours. After the first recharge, the cell impedance has gone down from 17 ohms to 9 ohms. There is decrease and increase of impedance between charge and discharge. This is typical of this type of cell because of the volume changes that occur.

(Figure 2-101)

Just to sort of give everybody an idea of what this type of cell can do without the lithium aluminum alloy which severely limits this deep discharge performance, here is some data obtained in the 1-inch diameter cell using the electrolyte that was developed, which was developed at EIC.

We ran this to try to compare with our own in-house developed electrolytes. This is the 1 mil hexofluorarsenate in 2 methyl THF. It is discharging essentially now at the 20-hour rate and is being charged at roughly the 50- or 60-hour rate.

Initial cell capacities are very good. They are about 40- or 50-milliampere-hours higher than the lithium aluminum anode cells, but at about between 20 and 25 cycles you start to see an increase in the cell impedance which is plotted here also from the values down in the 20s to values up in the 40s and 50s. And you see a dropoff in cell capacity.

If you drop the rate back as Gerhart also gave an example, the cell capacity does go back up. This is typical rate fading for a TIS to cathode.

(Figure 2-102)

The next vugraph shows some temperature testing that we have also done with this electrolyte in this cell configuration. We stored the cells for 1 month at 65 degrees. After this time, the cell impedance does go up a little bit. It just about doubles. But, your primary discharge capacity is still there. It is a little bit decreased, but we don't have really a lot of data.

We put the cell through 5 discharge cycles. The capacity dropped down to 74 milliamp-hours. We put the cells back in the oven for another month at 65 degrees. This is a very severe test for a lithium secondary cell for that active lithium which has been plated to let it have a chance to react with the electrolyte. After the second storage period at 65 degrees, we do see some dropoff in cell capacity. After a 10-deep discharge, the capacity is down to around 50 milliamp-hours.

(Figure 2-103)

I would like to summarize where we think this technology is now. These cells are ideally suited for solar rechargeable watch applications. They offer the user a hermetically sealed high-energy density cell that has excellent shallow-depth cycle life as would be encountered in a solar rechargeable watch.

Some of the cell capacity measurements are discharge data that go out to a total milliamp-hour capacities in the vicinity of 250 to 300 milliamp-hours. This is essentially equivalent to more than 10 years of watch operation.

They show the elevated temperature storage capability which is indicative of the basic material compatibility, and this type of cell charging behavior can be readily adapted to photovoltaic cells.

The cell design work was carried out by Chuck Morgan. The titanium disulfide materials, storing and electrified processing, was handled by Robert Francis. Oscar Montefusco and Antonio Romero took care of cell production and animation. Bruce Carstensen and George Galin took care of the cell dilution cycle.

Before I finish, I would just like to tell everyone that this limited cell technology is available for licensing. And anyone interested in it could contact Dr. Robert Hamlin at the Battery Division.

DISCUSSION

VASANTH: I would like to know whether these cells could be used to promote Diamonds' pattern principle in liquid crystal display watches?

MALACHESKY: The difficulty with using these cells in liquid crystal display watches is that they usually require a backlight which requires current ranges of about 7.5 to 15 milliamperes. These types of pulse requirements severely limit the use of these cells. These cells were made to be used in watches primarily which use the analog quartz mode of operation.

TYPICAL SOLAR RECHARGEABLE WATCH REQUIREMENTS

AVERAGE DISCHARGE RATE	2-3 μ A
CHARGE RATE (MAX)	1-2 mA
RANGE OF OPERATION	-10 $^{\circ}$ C/50 $^{\circ}$ C
CELL IMPEDANCE (MAX)	100 OHMS

Figure 2-93

RECHARGEABLE LITHIUM TITANIUM DISULFIDE CELLS

	LTS-90	LTS-25
DIAMETER, IN.	1.05	0.455
HEIGHT, IN.	_____	0.13
VOLTAGE RANGE	_____	2.0-1.4
CELL CAPACITY, mAHS	90	25
W HR/IN ³	_____	1.8
CELL IMPEDANCE, OHMS	7	25
SELF-DISCHARGE	_____	10%/YR

Figure 2-94

BUTTON CELL ASSEMBLY

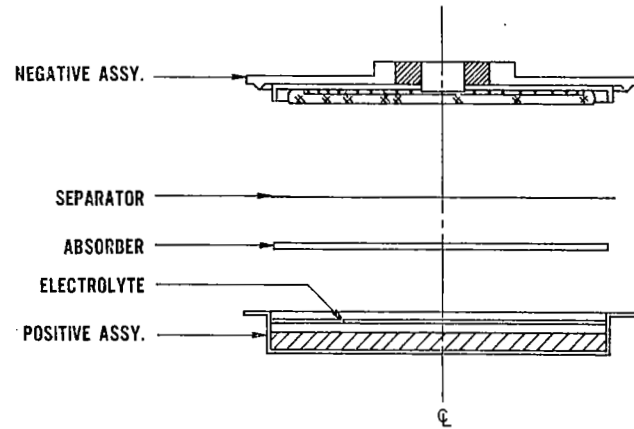

Figure 2-95

174

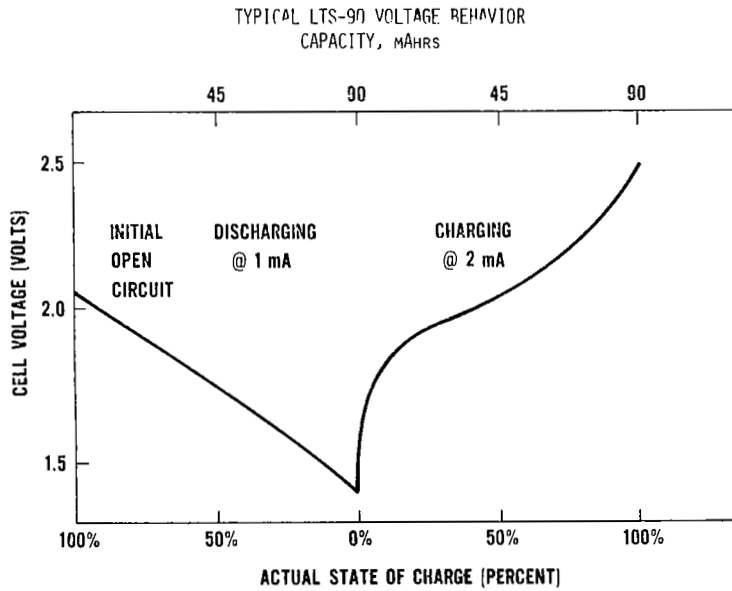

Figure 2-96

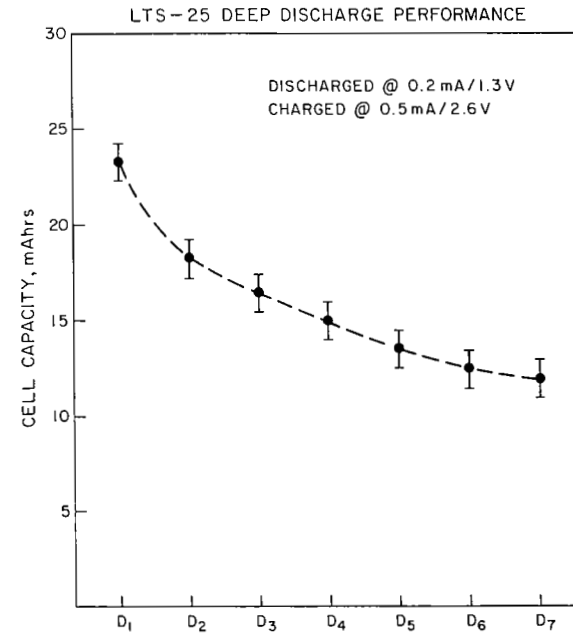

Figure 2-97

LTS-25 IMPEDANCE GROWTH TURNOVERS OF NOMINAL CAPACITY

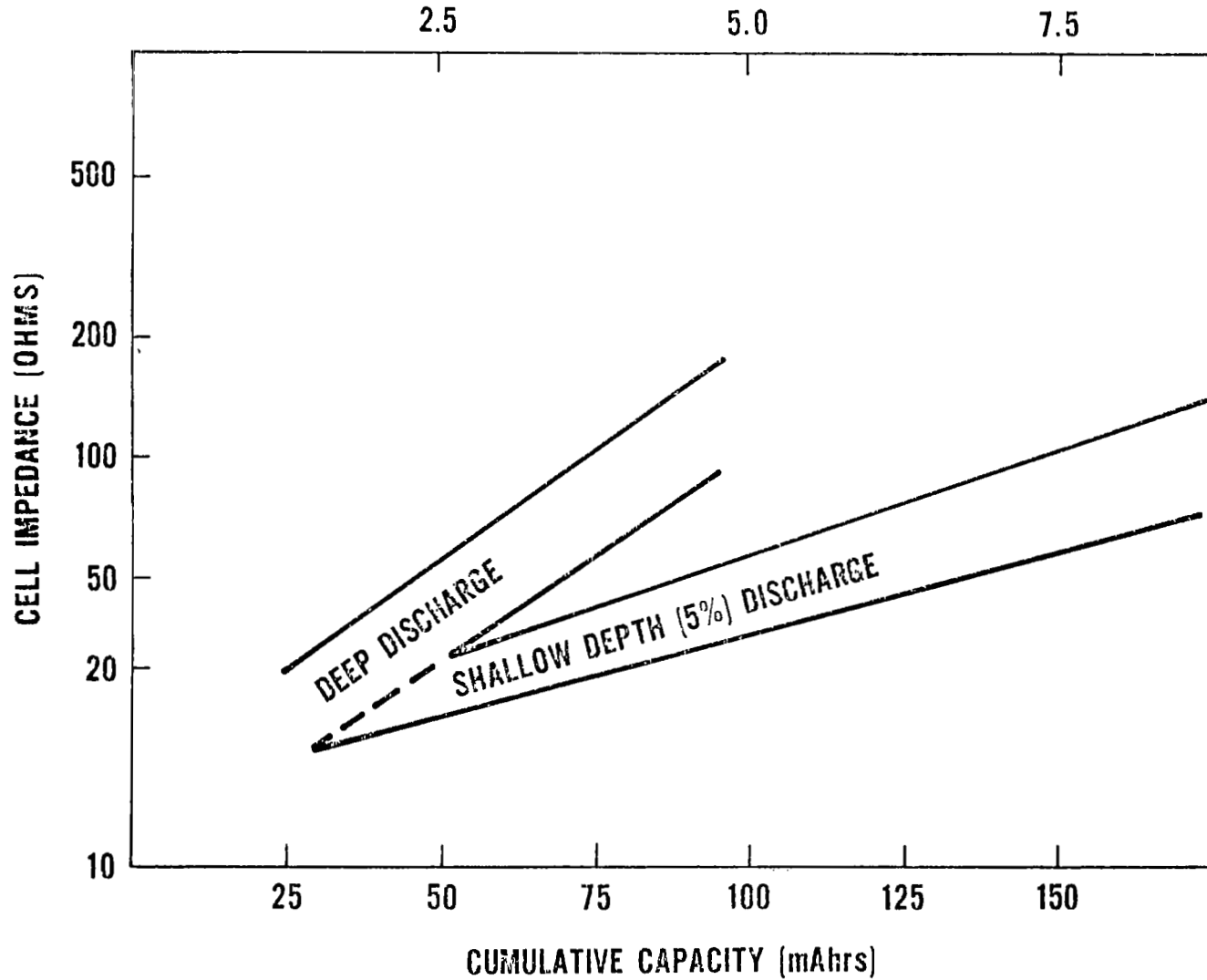

Figure 2-98

LTS-25 ENDURANCE TESTING

<u>CONDITION</u>	<u>CELL CAPACITY, MAHRS</u>	<u>CELL IMPEDANCE, OHMS</u>
INITIAL	-	24
25% DISCHARGED	6	22
SHALLOW CYCLING (5%DOD)	211	60
DEEP DISCHARGE #1	15	34
DEEP DISCHARGE #2	19	63
DEEP DISCHARGE #3	17	68

Figure 2-99

LTS-90 STORAGE CAPABILITY

	<u>IMPEDANCE OHMS</u>	<u>CAPACITY, MAHRS</u>
INITIAL	5	-
1 MONTH @ 65°C	5	-
2 MONTHS @ 65°C	6	-
3 MONTHS @ 65°C	6	-
AFTER FIRST DISCHARGE	17	95 ± 5
AFTER FIRST RECHARGE	9	

Figure 2-100

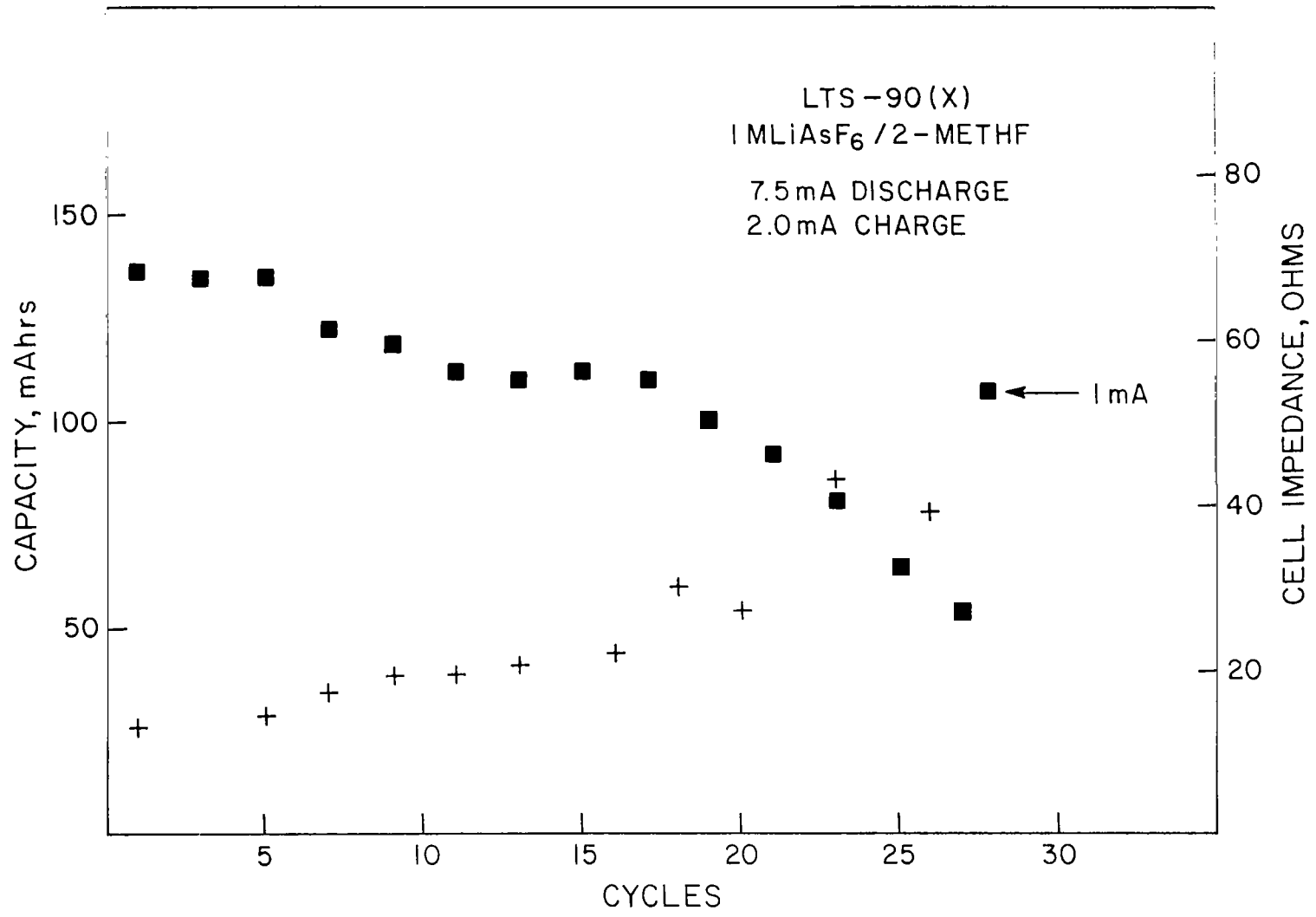

Figure 2-101

LTS-99(X) ENDURANCE TESTING (LIASF₆-2METHF)

<u>CONDITION</u>	<u>CELL CAPACITY, MAHRS</u>	<u>CELL IMPEDANCE</u>
INITIAL	-	37
AFTER 1 MO. @ 65 ⁰ V	114	74
AFTER DEEP DISCHARGE #5	74	43
AFTER 1 MO. @ 65 ⁰ C	54	64
AFTER DEEP DISCHARGE #10	49	49

Figure 2-102

SUMMARY

RECHARGEABLE LiAl/TiS₂ BUTTON CELLS ARE IDEALLY SUITED FOR SRW APPLICATIONS SINCE THEY OFFER THE USER:

- A HERMETICALLY SEALED, HIGH ENERGY CELL
- EXCELLENT SHALLOW DEPTH CYCLE LIFE
- ELEVATED TEMPERATURE STORAGE CAPABILITY INDICATIVE OF BASIC MATERIALS COMPATIBILITY
- CELL CHARGING BEHAVIOR READILY AMENABLE TO PHOTOVOLTAIC RECHARGING

Figure 2-103