

Dp

N80 23505

MECHANISMS OF UK RADIOMETERS FLOWN ON NIMBUS 5 AND 6
WITH PARTICULAR REFERENCE TO BEARINGS, PIVOTS AND LUBRICATION

H. Hadley
Rutherford and Appleton Laboratories
Science Research Council U.K.

SUMMARY

The mechanisms incorporated in these two experiments which were launched on Nimbus 5 in 1972 and on Nimbus 6 in 1975 are currently still working perfectly. The experiments described are vertical sounding infrared radiometers mainly for measurement of temperature profiles. Both use dry lubricants.

The Nimbus 5 Radiometer includes a rotating chopper driven via a carbon fibre-acetal resin gearwheel. The driving motor runs at 2000 rpm and has completed over 7×10^9 revolutions. Four gear driven filter wheels powered by stepper motors have each completed 2×10^8 changes. The input calibration mirror mechanism and its field of view compensation mechanisms are also described. All 25 ball races used in the experiment are of the film transfer type.

The Nimbus 6 Radiometer includes two cells. Each contains a piston supported on diaphragm springs and driven electromagnetically to modulate the pressure of CO₂ gas in the optical path. The pistons are 6 cm in diameter with a stroke of 1 cm and are driven at their mechanical resonant frequency of ≈ 15 Hz. The calibrating mirrors rotate periodically to view a target, Earth, and space, with the earth view scanned along the satellite track. The support pivots are synthetic sapphire ring stones with separate end thrust stones. The problems of mounting these stones to withstand vibration loads is described.

INTRODUCTION

The two experiments described in this paper are infrared vertical sounding instruments to measure the temperature profiles of the atmosphere. They were devised by the Department of Atmospheric Physics, Oxford University, under Professor J. T. Houghton with the engineering design and project management support being provided by the Rutherford Laboratory of the Science Research Council. The flight models were made by Marconi Space and Defence Systems.

These experiments are of interest since they all involve some innovation in the use of lubricants in small mechanisms in space and have proved highly successful in application. At the time of writing, they are all still

~~TOP SECRET~~ INTENTIONALLY CLASSIFIED

working as perfectly as when they were launched. These lubrication aspects are the use of carbon-fibre acetal resin gears in the Selective Chopper Radiometer (SCR) on Nimbus 5 (launched 1972) and the use of synthetic sapphire ring and thrust bearings in the Pressure Modulated Radiometer (PMR) on Nimbus 6 (launched 1975). A companion paper (ref. 1) describes the mechanisms used on the Stratospheric and Mesospheric Sounder (SAMS) on Nimbus 7 (launched 1978) in which lead lubricated recirculating ball screws are used.

NIMBUS 5 SCR MECHANISMS

This experiment (ref. 2) is a 16 channel vertically sounding radiometer ($\lambda = 15 \mu\text{m}$ to $100 \mu\text{m}$) and its 8 main channels measure the temperature profile of the atmosphere up to 45 km in height. As shown in figure 1, the incoming radiation is directed by the calibration mirror to a 13-cm-diameter off-axis paraboloid mirror and focused to pyroelectric detectors. Interposed before the detector is a double sided reflecting chopper set at 45° which chops and directs the field of view (FOV) into two paths; a dichroic beam splitter is placed in each path to feed 4 detectors in total and in front of each detector is a four position filter wheel, thus providing the 16 channels. A view to space is arranged opposite the chopper so that when the through view is chopped the rear face of the chopper directs the detector view to space and when the through view is clear the other detectors look to space through the chopper gap. The chopper is 12.7-cm-diameter, 0.25-cm-thick aluminium, diamond cut and gold plated with 2 cut-outs of 90° and is driven at 1200 rpm to give a 40-Hz signal chopped between atmosphere and space.

Chopper

The driving motor is a standard 400-Hz, 8000-rpm hysteresis motor (Muirhead Type 11M18F1) but with the bearings replaced by "BarTemp" bearings (Barden Corpn.) which are deep groove instrument ball bearings with a cage of glass fibre reinforced PTFE loaded with MoS_2 . The balls transfer the lubricating film from the cage to the raceways. The motor is driven from the spacecraft 100-Hz two-phase supply at 2000 rpm, thus requiring a gear reduction. A stainless steel gear is coupled by a splined driving plate with the outrigger bearing supporting a flywheel of "Heavimet" (Tungsten-copper alloy) to compensate the angular momentum of the chopper disc. The 60T meshing gear is made of chopped carbon fibre (25%) and "Delrin" (Du Pont's acetal homopolymer of formaldehyde) in which the carbon fibre limits the wear and the "Delrin" provides the lubrication. See figure 2 and reference 3. This chopper was rotating during launch to prevent "Brinelling" of the ball race tracks.

The two phase motor windings are each split into two halves and each is powered independently to give complete redundancy and in fact once up to speed the motor will run on one of its four windings. The full power dissipated is 6 watts.

Filter Wheels

The filter wheels are also gear driven from stepper motors to reduce the effects of inertia so that a 90° motion of the filter wheel can be completed accurately in less than 150 ms and repeated every second allowing a signal

integration period of 820 ms. The four filters on each wheel are glued into titanium holders and set into an aluminium wheel with the outer rim supporting the teeth of a standard machine cut delrin gear wheel. Two sizes of wheel are used, each with 120 teeth 40 DP and 48 DP. The largest wheel supports four gas cells with a 0.3-cm path length between 2.3-cm-diameter germanium windows-filled with CO₂ at various pressures up to a maximum of 350 mbar. The permanent-magnet 90° stepper motors are IMC type 011-804-1 (IMC Magnetics Corp.) which is a space qualified component using "BarTemp" bearings. To the shaft is clamped a 15 tooth stainless steel pinion, thus providing a programme of 8 steps. These steps are at 10-ms intervals with the last pulse delayed to 20 ms and quadrature damping applied by a negative impedance circuit. This, together with the inertias and other system parameters, calculations and measurements, is shown in reference 4. The four filter wheels are driven in step, and should any filter be out of position at the beginning of the 4-second cycle, they all wait until the late filter catches up. To do this, a slow stepping sequence is applied to any filter wheel not in the number one position. Positioning is by opto-transducers from reflecting tracks.

Each filter wheel is encased in an isothermal temperature controlled shroud and figure 3 shows one of the smaller wheels with the cover and input port removed.

Calibration Mirror

The calibration mirror is a plane, diamond-cut, aluminium mirror of elliptical form, 20 cm x 14 cm, set at 45° to the nadir. It rotates 90° to view an internal black body and then a further 180° to view space. This occurs twice per orbit. The drive motor is a 90° stepper motor, type IMC 015-802, which is energised with triangular waveforms to provide a smooth torque and to limit the current demand from the spacecraft supply to the permitted rate of rise. This assembly is also pivoted about its centre of gravity so that the mirror is able to scan backwards along the line of the spacecraft motion so the same field of view is seen by each filter for the 4 seconds necessary. The return scan takes place during the 150 ms of the last filter change. The pivot bushes that support this assembly are made of "Vespel" type SP3 (Du Pont's polyimide resin). The field of view compensation mechanism is a long arm connected to a linear motor producing 0.75' mirror movement. This motor consists of a ferrite ring permanent magnet with pole pieces and coil, as in a loudspeaker, with two coil-support diaphragm springs of beryllium copper and a flexible beryllium copper connection to the lever arm. The coil is supplied with the appropriate sawtooth waveform and its movement is monitored by means of redundant sets of gallium arsenide light sources and silicon diode detectors, as are all the other mechanisms used in these radiometers. The position of the calibration mirror in the de-energised positions is held by the normal 'detent' of the stepper motor assisted by permanent magnet pairs and, in the extreme positions of normal vertical viewing and space viewing, the detent magnets are offset to hold the mirror against fixed stops. (See fig. 4 for a sectional view of the mirror and its FOV compensation).

Some 25 ball races were used on this radiometer all "BarTemp" types used well within the manufacturers recommendations and all pre-loaded by separate coil springs or in the case of the motors by spring washers. The pre-loads

are between 1-2N. The application of these bearings is also well within the performance guide for self lubricating bearings in air published in 1976 by the National Centre of Tribology at Risley. (Ref. 5).

The complete radiometer is 31 x 20 x 43 cm, weighs 14 kg, and consumes 15 watts. It is suspended under the spacecraft and was qualified by vibration testing to 7.5g (5 Hz to 2000 Hz) sine wave and 15g rms (20 Hz to 2000 Hz) random (0.11 g²/Hz). A separate electronics module, 15 x 17 x 22 cm, weighing 5 kg provides the power converters and the electronic drive systems. This radiometer has now completed 60 000 hours of operation (over 2 x 10⁸ filter movements per wheel and 7 x 10⁹ revolutions of the copper motor, which must be approaching the theoretical predictable ball race life (ref. 6).

NIMBUS 6 PRESSURE MODULATOR RADIOMETER MECHANISMS

This instrument is also a vertical sounding radiometer with 2 channels to measure the temperature profile of the atmosphere from 40 km - 60 km (channel 1) and 60 km to 90 km (channel 2). Each channel has its own pressure modulated cell and calibration mirror system and measurements are confined to the 15 μm band. (Ref. 7).

Calibration Mirror System

The calibration mirrors operate in a similar manner to that of the SCR instrument except the mirror is only 7 x 5 cm and is mounted directly onto the shaft of an IMC 008-845 stepper motor. The image motion compensation of the SCR instrument was extended to give a direction of view $\pm 15^\circ$ from the nadir along the direction of flight. This introduces a varying Doppler shift which varies the optical depth and, hence, the altitude being sounded. The mechanism for this is an actuator consisting of a curved fixed magnet with a moving coil which can move over an arc of $\pm 7.5^\circ$ and is restrained mechanically only at its end stops. An inductive position pick-off signals the actuator to follow a saw-tooth ramp waveform. The time for a single doppler scan is 85 seconds.

The pivot bearings for this motion were a problem. "BarTemp" bearings need a larger movement for the balls to lay down a lubricated track, polyimide resin sleeve bearings tended to judder for such small slow movements, and suitable flexural pivot bearings require more power at the extremes of motion than the actuator could give.

However, tests were done on a possible flexi-pivot as had also been done previously for the SCR mirror pivots, but again the vibration loads were too great. If larger flexi-pivots were used, the spring loads to be overcome would need more power than could be provided from the drive servo. The limitation with crossed spring flexi-pivots is their rigidity to axial loads which cause the spring leaves to buckle. One way to overcome this problem without using stiffer, stronger flexi-pivots is to relieve the pivot of all axial loads or to clamp during launch.

The decision, after much testing, was to use synthetic sapphire ring bearings with separate thrust end stones. However for these to withstand

vibration testing, they had to be pressed into a titanium ring, mounted in silicon rubber, and off-loaded so that metal-metal contact occurred within 0.01 cm of movement. The 0.2-cm-dia shaft of the bearing is a hard stainless steel, since normal stainless steels are not hard enough to stand the wear. 9% Chromium stainless steel (Firth-Vickers 520B Hardness Rockwell C46) was found to be suitable. Hardened AISI 440 stainless steel would also be suitable. This worked very smoothly with minimum power from the servo system (See Fig. 5 and Ref. 8). The end stones were fixed, with the shaft ends radiused to 0.4 cm and polished with 0.005 cm axial clearance. The ring stones were 0.5 cm o.d. and 0.125 cm thick. The bore was not parallel but olive shaped (radius, 0.2 cm), which allows for misalignment and the removal of wear debris. The shafts were lapped to fit so that they could be angled 3° min to 5° max. (i.e. clearances of 3 to 8 μm). The total weight supported was 0.15 kg, and test vibration levels were 10 g (sinusoidal) and 13.4 g r.m.s. (random excitation).

Pressure Modulated Cell

This is a very elegant concept compared to the mechanics of the selective chopper radiometer. Instead of a rotating chopper, a piston is driven up and down modulating the pressure of CO₂ in a cell. To change the mean pressure, the temperature of a molecular sieve is changed, instead of switching cells in front of the detector. The cylinder and cell are made of titanium 130 which has excellent outgassing characteristics and is sufficiently hard to allow good permanent seals using 0.05-cm-diameter gold 'O' ring seals on demountable flanges. The piston is 6-cm dia and is made of titanium 679 which has 11% tin and does not scuff or pick up the titanium 130 of the cylinder. The radial clearance is 0.005 cm and the total stroke is 1 cm. The mechanical arrangement is shown also in Fig. 5 with the piston mounted on a shaft with a permanent magnet set in the centre and flat beryllium copper spider springs of constant stress cross section providing the support. The tail end of the shaft carried a position pick-off ferrite rod, and the position was sensed by an externally mounted coil. Drive electromagnets outside the cylinder are servo controlled to drive the piston at constant amplitude at its mechanical resonant frequency of about 15 Hz.

The pressure control is achieved by thermostating a small quantity (2gm) of molecular sieve material which will absorb CO₂ (a zeolite from Union Carbide type 4A XH/2). The equilibrium pressure above the sieve is only a function of temperature for a given filling of CO₂, for the volume and quantity of sieve material chosen. The pressure in channel 1 (1-cm-long cell) is changed from 0.5 mbar at 30°C to 3 mbar at 80°C and in channel 2 (6-cm-long cell) is 1 to 6 mbar over these temperatures. Five values can be selected on command. A position of maximum temperature was switched in during launch to provide maximum damping to the piston system from vibration and the spring stops are shaped to progressively limit the spring movement and thereby change the natural frequency once the 1-cm amplitude has been exceeded.

The measurement of gas pressure is deduced from the frequency of oscillation of the piston assembly which changes by nearly 10% per mbar pressure change. A 10 bit counter, reset every 32 seconds, allows the data system to record this to 1% accuracy.

The complete PMR radiometer is 23 x 18 x 41 cm, is made integral with its electronics module, weighs 13 kg, and consumes 5 watts. This unit is mounted inside the sensory ring of the spacecraft so the vibration levels are only 50% of the SCR levels. It has completed over 4 years operation in orbit and is operating perfectly, but recently data have only been recorded periodically as an economy in ground control and data handling. At present, however, it is operating continually for comparison with the Nimbus 7 SAMS instrument.

CONCLUSION

In the design of these experiments we have conscientiously avoided the use of oil or grease to reduce the risk of contamination of optical components. For the chopper gearbox, a design using labyrinth seals with a grease lubricant was tested, but it was not satisfactory in this respect.

The use of ball races with film transfer lubrication from the cage (such as the "BarTemp" types) has proved ideal in these experiments where they are used well within the guidelines. The life of nearly 10^{10} revolutions in the chopper gearbox is outstanding for any lubricant. The limitation of the lubricating method means that angular rotation to lay down a track must exceed 30° or so.

For limited movements, diaphragm springs and flexible connections have given very good service. The design, however, must incorporate mechanical stops to prevent distortion of the joint under working, launch, and test conditions and stress so that the fatigue life is many times the experiment life.

The use of jewel bearings as pivots has been demonstrated and, over the 4 years in orbit, each mirror has totalled nearly one million scans of 15° total movement. However, the friction of these stone ring bearings is greater than that of film transfer bearings and should be considered only where use of the latter is not possible.

COMPONENT SUMMARY

Hysteresis motor	Muirhead Ltd Beckenham, Kent	Type 11M18F1, 2ph., 400 Hz, split winding.
Film Transfer Bearings	Barden Corpn. Bracknell, Berks	"BarTemp" instrument ball bearings
Carbon Fibre-Delrin	RAE Farnborough (originally) AERE Harwell, Oxon	Production now at AERE for Contract stock for ESTEC
"Vespel" SP3	E.I. du Pont de Nemours Wilmington, DE 19898	Polyimide self-lubricating resin material (loaded)
Stepper Motors	IMC Magnetics Corpn. Maywood, Calif. 90270	Permanent Magnet 90° Stepper Motors (Size 8, 11 & 15)
Sapphire Jewel Bearings	Fred Lee & Co (Coventry) Ltd Coventry. CV4 9BJ	Ring Stone and thrust stones (Stockist)
Opto transducers	Texas Instruments Ltd Slough, Berks	Gallium Arsenide Source TIL23 Silicon light sensor LS616
LINDE Molecular Sieve	Union Carbide Corpn. East Chicago Indiana 46312	4A XH/2 $\frac{1}{8}$ " dia beads (sodium metal alumino-silicate)
"Heavimet" heavy alloy	Osram (CEC) Wembley Middx	Copper-Tungsten, Density 18

REFERENCES

1. Hadley, H.: The Mechanisms of the SAMS Experiment Flown on Nimbus 7. 14th Aerospace Mechanisms Symposium, NASA CP-2127, 1980 (Paper 27 of this compilation).
2. Ellis, P.; Holah, G.; Houghton, J.T. FRS.; Jones, T.S.; Peckham, G.; Peskett, G.D.; Pick, D.R.; Rodgers, C.D.; Roscoe, H.; Sandwell, R.; Smith, S.D.; and Williamson, E.J.: Remote sounding of atmospheric temperature from satellites IV. The selective chopper radiometer for Nimbus 5. Proc. R. Soc. Lond. A. 334, 149-170 (1973).
3. Harris, G.L.; and Wyn-Roberts, D.: Wear of Carbon Fibre Reinforced Polymers in a high vacuum environment. Nature Vol. 217, 981-982. (1968).
4. Ellis, P.J.: Analysis and Control of Permanent Magnet Stepper Motor. The Radio & Electronic Engineer. Vol. 41, 302-308. (1971).
5. Performance Guide for Self-Lubricated Bearings. N.C.T. Risley (1976).
6. Patrick, J.J.: Stepper Motor experience in Space instrumentation. ESA-SP111. 143-147 (1975).
7. Curtis, P.D.; Houghton, J.T. FRS; Peskett, G.D.; and Rodgers, C.D.: Remote sounding of atmospheric temperature from satellites V. The pressure modulator radiometer for Nimbus F. Proc. R. Soc. Lond. A. 337, 135-150 (1974).
8. Dokuchalova, V.V.; Uskova, S.G.; and Khandelsman, Yn. M.: Design of Ring Jewel Bearings for Small Frictional Torques. Translated from Russian in Instrument Construction No. 2. 15-18 (1963).

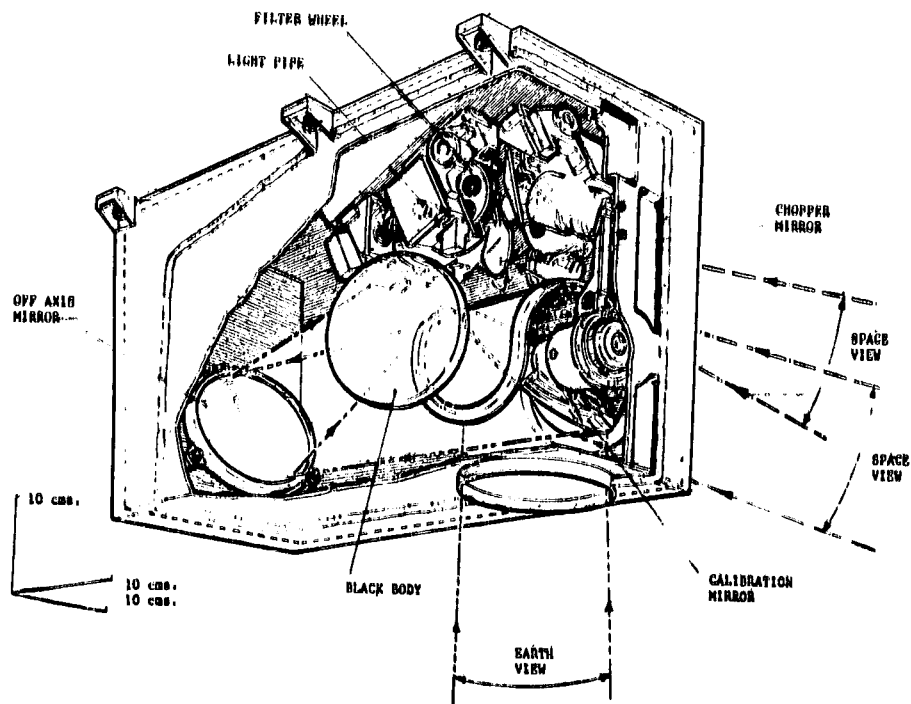

Figure 1.- Selective chopper radiometer on Nimbus 5.

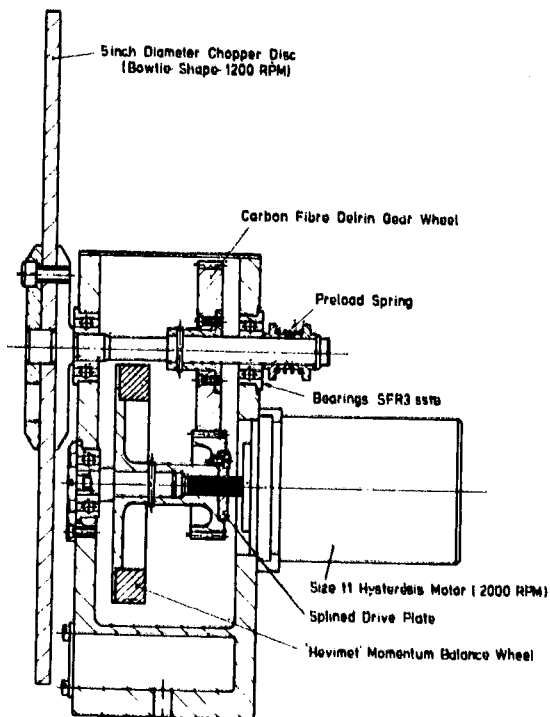

Figure 2.- Chopper gearbox for S.C.R.

ORIGINAL PAGE IS
OF POOR QUALITY

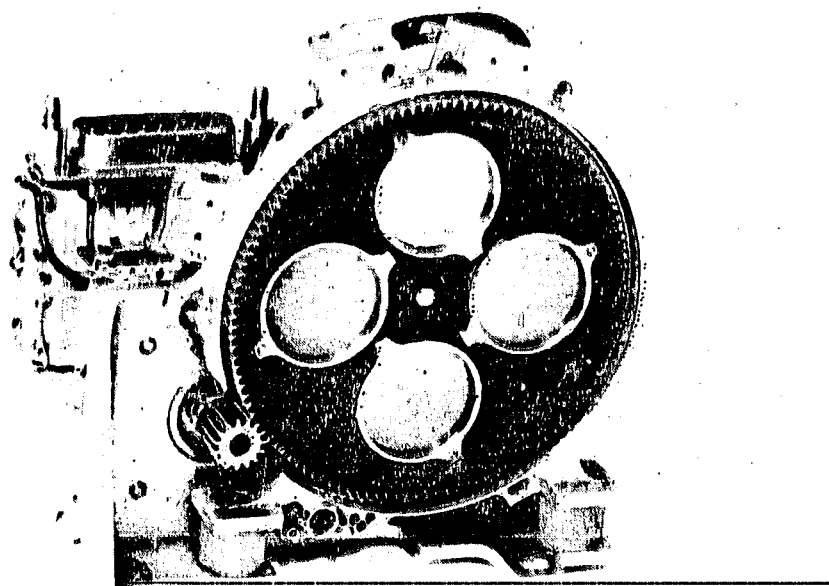

Figure 3.- Filter wheel assembly for S.C.R. (eng. model with cover removed).

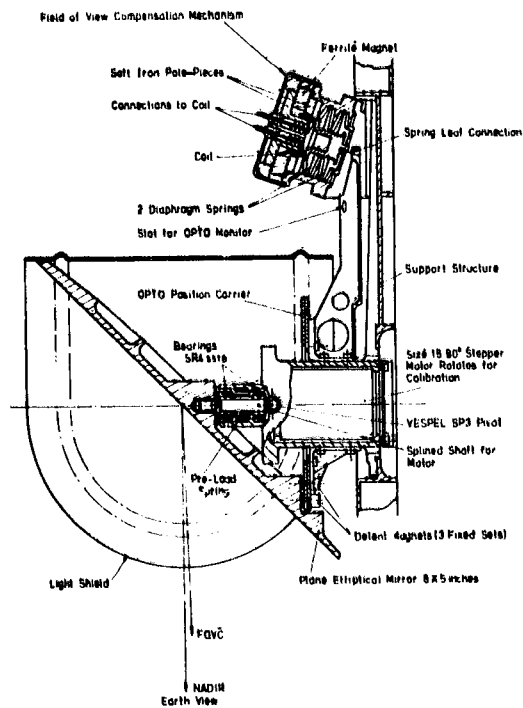

Figure 4.- Calibration mirror mechanism for S.C.R.

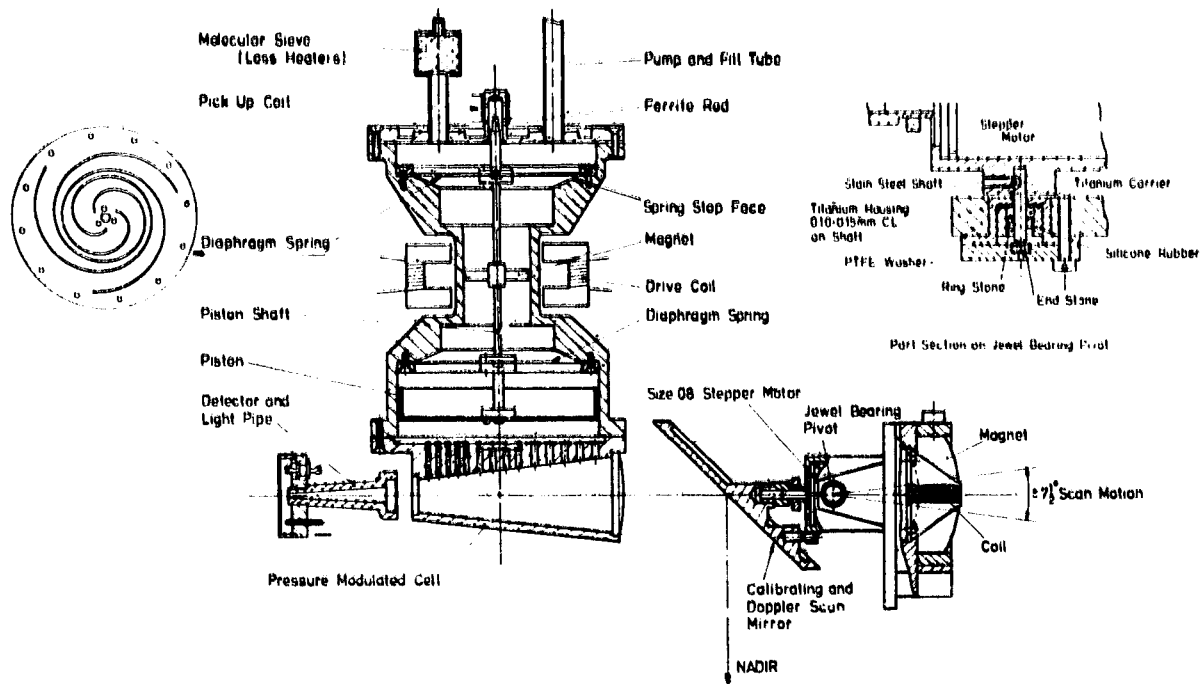

Figure 5.- Pressure modulator radiometer (one channel only) on Nimbus 6.