

SOLAR ROCKET SYSTEM CONCEPT ANALYSIS*

Jack A. Boddy
Rockwell International Corporation

The use of solar energy to heat propellant for application to earth orbital/planetary propulsion systems is of interest because of its unique performance capabilities. The achievable specific impulse values are approximately double those delivered by a chemical rocket system, and the thrust is at least an order of magnitude greater than that produced by a mercury bombardment ion propulsion thruster. The primary advantage the solar heater thruster has over a mercury ion bombardment system is that its significantly higher thrust permits a marked reduction in mission trip time.

The concept of using solar energy to heat propellants for use in an earth orbital/planetary rocket propulsion system is not new. In 1962, for example, the Air Force Rocket Propulsion Laboratory (AFRPL) sponsored an analytical and experimental program to demonstrate the feasibility of the solar heated rocket engine. In a test program conducted at the AFRPL, a specific impulse of 680 seconds was achieved. The thruster utilized hydrogen as the propellant. Although the initial results were encouraging, the program was not pursued. The performance capabilities of the launch vehicles available in the early 1960's were such that the full potential of the solar rocket could not be realized. The development of the Space Transportation System (STS), however, offers the opportunity to utilize the full performance potential of the solar rocket. As the 1980-1990 time period approaches, a far greater number and variety of mission requirements have been identified than in the early 1960's that could potentially use solar rocket propulsion systems.

Objectives

The basic study objectives as stated were subjected to the guidelines of a mission model concerned with transfer from low earth orbit (LEO) to geosynchronous equatorial orbit (GEO). The return trip, GEO to LEO, both with and without payload, was also examined. Payload weights considered ranged from 2000 to 100,000 pounds. The performance of the solar rocket was compared with that provided by LO_2-LH_2 , N_2O_4-MMH , and mercury ion bombardment systems.

OBJECTIVES

THE OBJECTIVES OF THE SOLAR ROCKET SYSTEM CONCEPT ANALYSIS STUDY WERE TO PROVIDE AN ASSESSMENT OF THE VALUE OF SOLAR THERMAL PROPULSION RELATIVE TO MORE CONVENTIONAL PROPULSION CONCEPTS, AND TO DEVELOP AN UNDERSTANDING OF THE FACTORS WHICH BEAR ON ITS TECHNICAL FEASIBILITY.

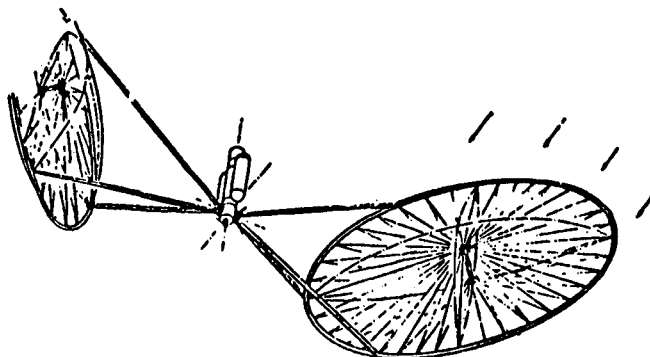

*Sponsored by the Air Force Rocket Propulsion Laboratory under Contract F04611-79-C-0007, Final Report, AFRPL-TR-79-79.

Payload Weight as a Function of ΔV and Specific Impulse

Payload weight for a range of ΔV 's is presented for specific impulse values ranging from 500 to 1100 seconds, and a Shuttle separation weight of 62000 pounds. This range of specific impulses are obtainable for representative solar rocket systems. The velocity requirements for low earth orbit (LEO) to geosynchronous orbit (GEO) are about 14000 ft/sec for chemical propulsion system employing high thrust to weight ratios. For the solar rocket system with $T/W \leq 10^{-3}$ the velocity requirements for the continuous burn condition are 19200 ft/sec. The improvement in the higher specific impulse combined with the increase in velocity requirements still results in significant improvements in payload delivered to GEO.

PAYLOAD WEIGHT AS A FUNCTION OF ΔV AND SPECIFIC IMPULSE

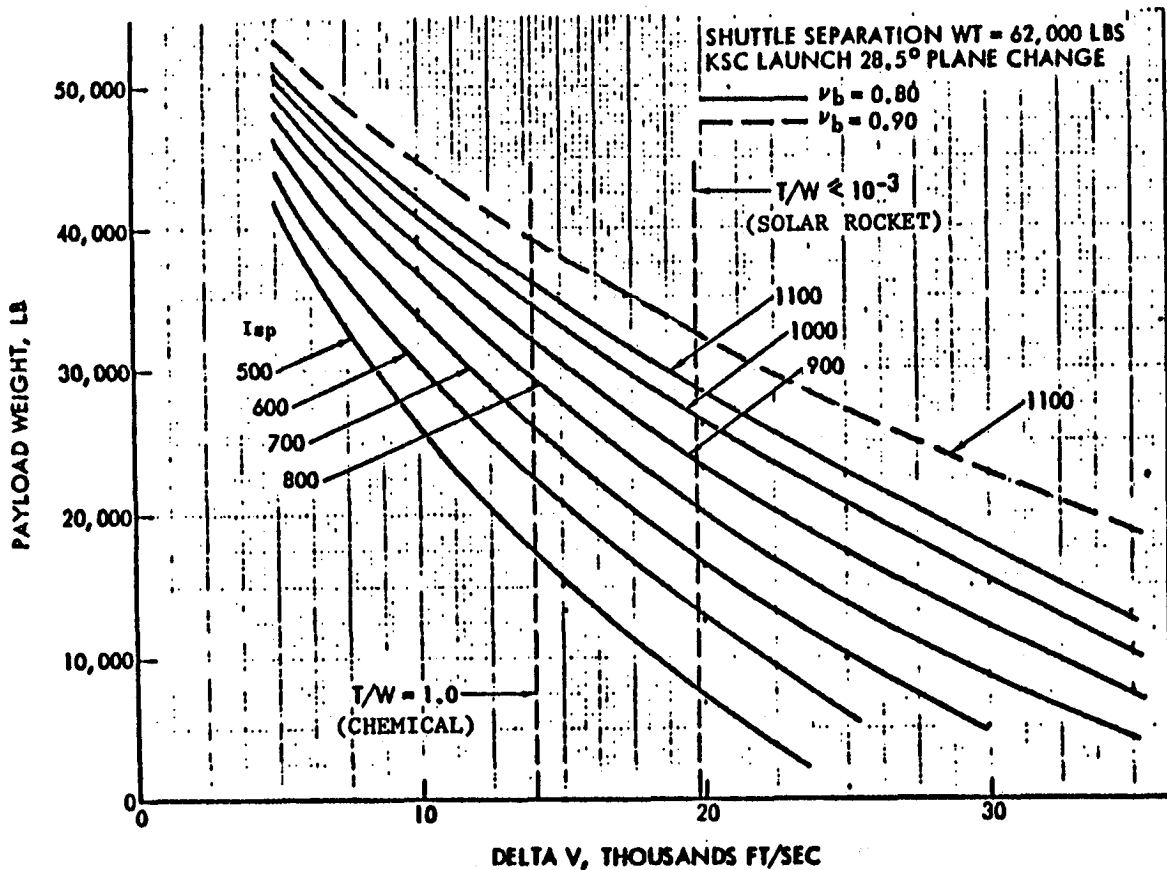

Delta - V Requirements vs Thrust-to-Weight

The classical two-impulse transfer, with one impulse at perigee and the second impulse at apogee, is commonly associated with transfer vehicles having a thrust-to-weight ratio considerably above 0.1. The mission velocity for such a vehicle corresponds to approximately 14,000 fps and a trip time of 5.27 hours.

Lower thrust-to-weight vehicles may also fall into this two-impulse transfer category as long as the corresponding burntime is generally shorter than the transfer time and the transfer trajectory still resembles an ellipse. The corresponding mission velocity would be considerably higher; and the trip time, although also increasing, would still be generally less than a day.

On the other end of the orbital transfer spectrum is the transfer maneuver associated with vehicles having thrust-to-weight ratios below 0.001. These classical, extremely low thrust-to-weight orbit transfers are characterized by a continuous burn spiral trajectory. Although this type of trajectory represents the shortest trip time for low thrust-to-weight propulsion system it also demands the greatest energy expenditure. The mission velocity in this regime is 19,200 fps, and the value remains essentially independent of vehicle thrust-to-weight ratio. The low thrust-to-weight solar rocket system results in trip times in excess of 10 days.

DELTA-V REQUIREMENTS VERSUS THRUST TO WEIGHT

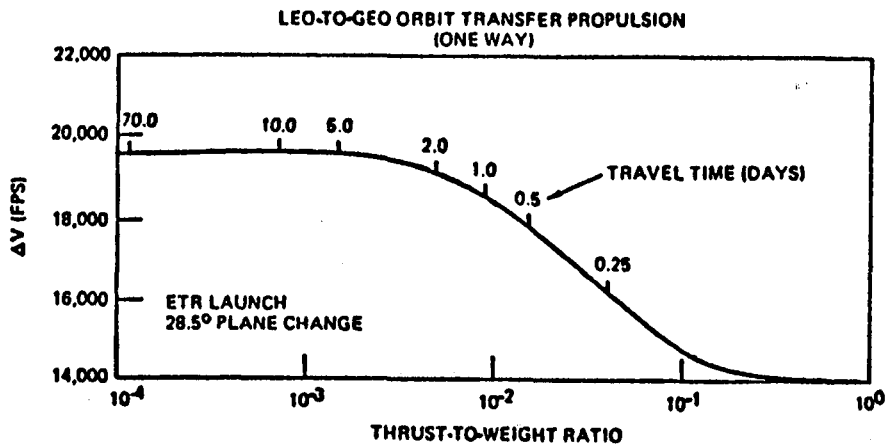

Payload Capability for Various Propulsion Systems

The payload delivered to GEO by chemical systems and the solar rocket using LH₂ are shown for a range of stage mass fractions and typical ranges in their respective specific impulses. It is clearly seen that the solar rocket at the higher velocity requirements of 19,200 ft/sec must have specific impulses in excess of 800 Secs in order to improve performance over the cryogen propulsion stages (LO₂-LH₂).

PAYLOAD CAPABILITY FOR VARIOUS PROPULSION SYSTEMS

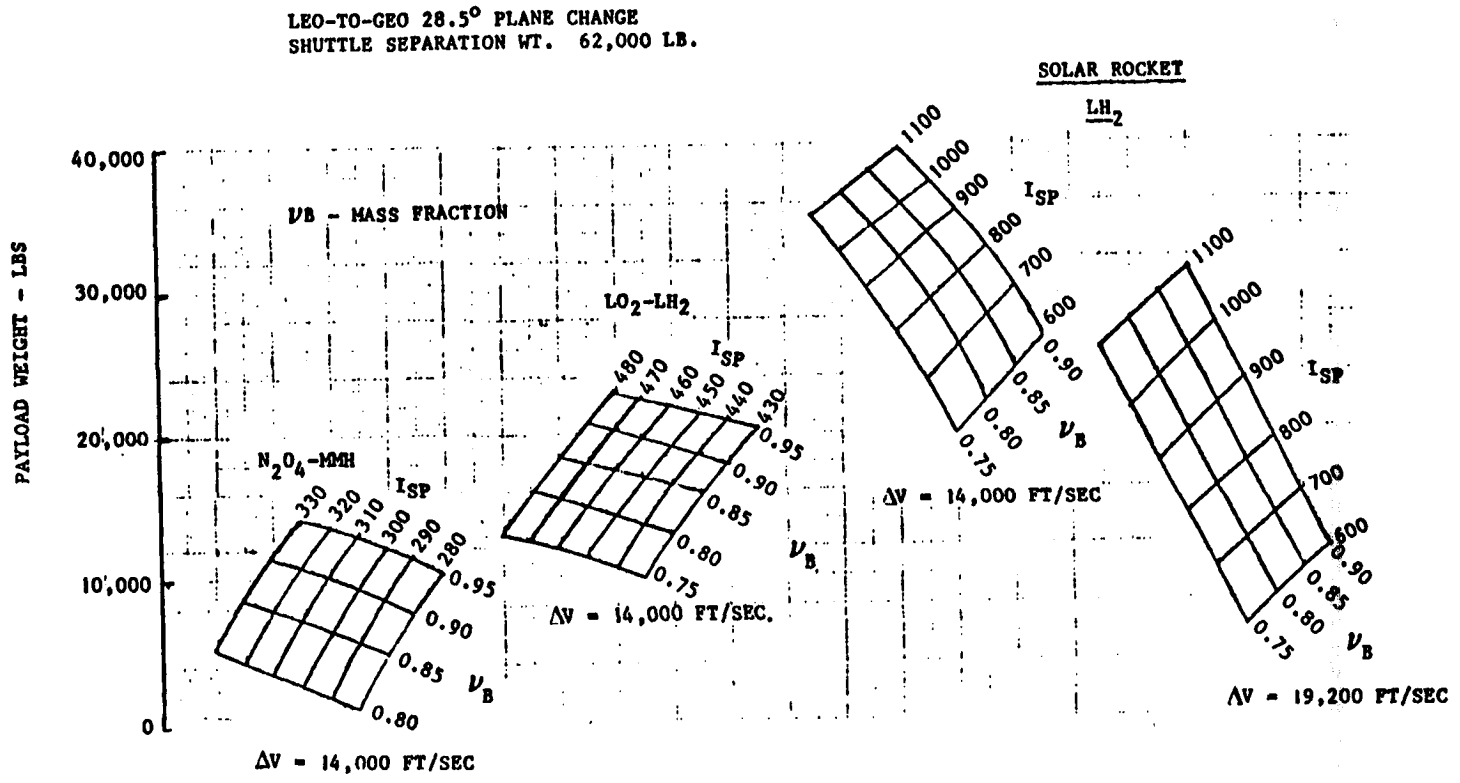

Payload as a Function of Tank Geometry and Specific Impulse

The nominal dimensions of Shuttle cargo bay are 15 feet in diameter and 60 feet long. The LH₂ propellant will require the use of multilayer insulation systems, and an allowance for cradle thickness must also be made. Tankage inside diameters of 13.5, 14.0, and 14.5 feet have been assumed. The usable length of the cargo bay is 56 feet to allow for clearance and removal for the bay. Because of the low density of liquid hydrogen (4.4 lb/ft³) the tank volume required to hold the quantity of propellant consistent with a 62,000-pound separation weight may exceed the usable volume of the cargo bay. The length of the hydrogen tank required as a function of diameter for the 62,000-pound separation weight constraint, shows that the vehicle tends to be limited by the orbiter's volume constraints.

PAYLOAD AS A FUNCTION OF TANK GEOMETRY AND SPECIFIC IMPULSE

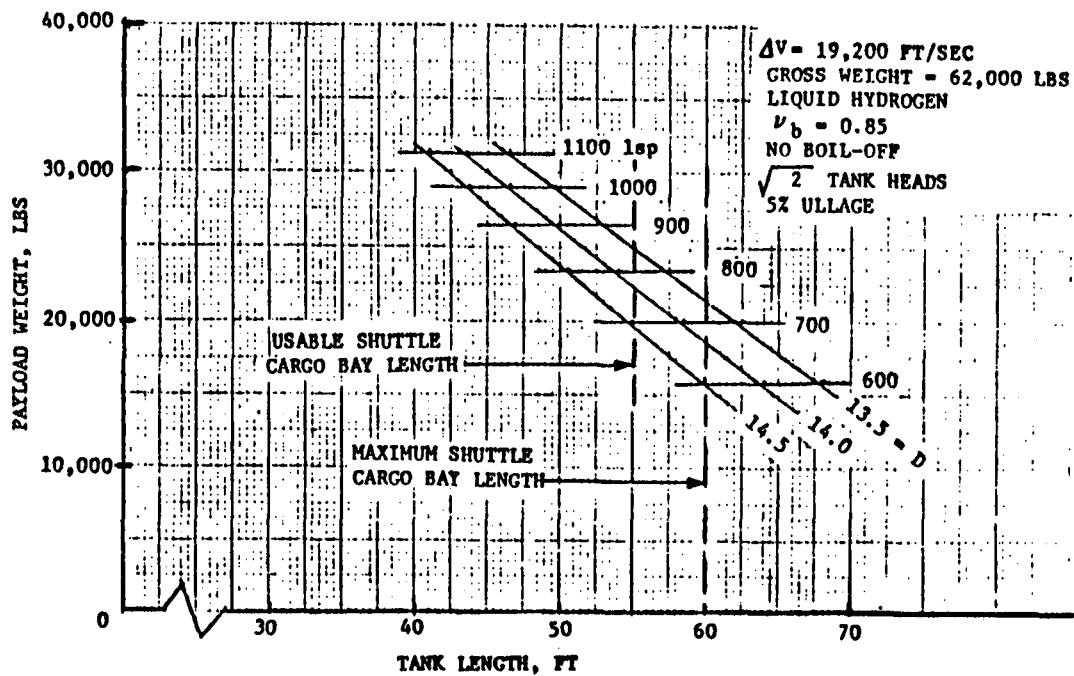

Payload Weight as a Function of ΔV - LH_2 and NH_3

Compared on this chart are the relative performance of two fuels used for the solar rocket. The denser NH_3 is not limited by the orbiter's cargo bay volume for the higher velocity increments, but with its lower I_{sp} = 440 secs has lower payload delivery capability than the LH_2 system constrained to a 40 foot long tank. This length will allow bay length to include the thruster, collectors and payload envelopes.

PAYLOAD WEIGHT AS A FUNCTION OF ΔV - LH_2 AND NH_3

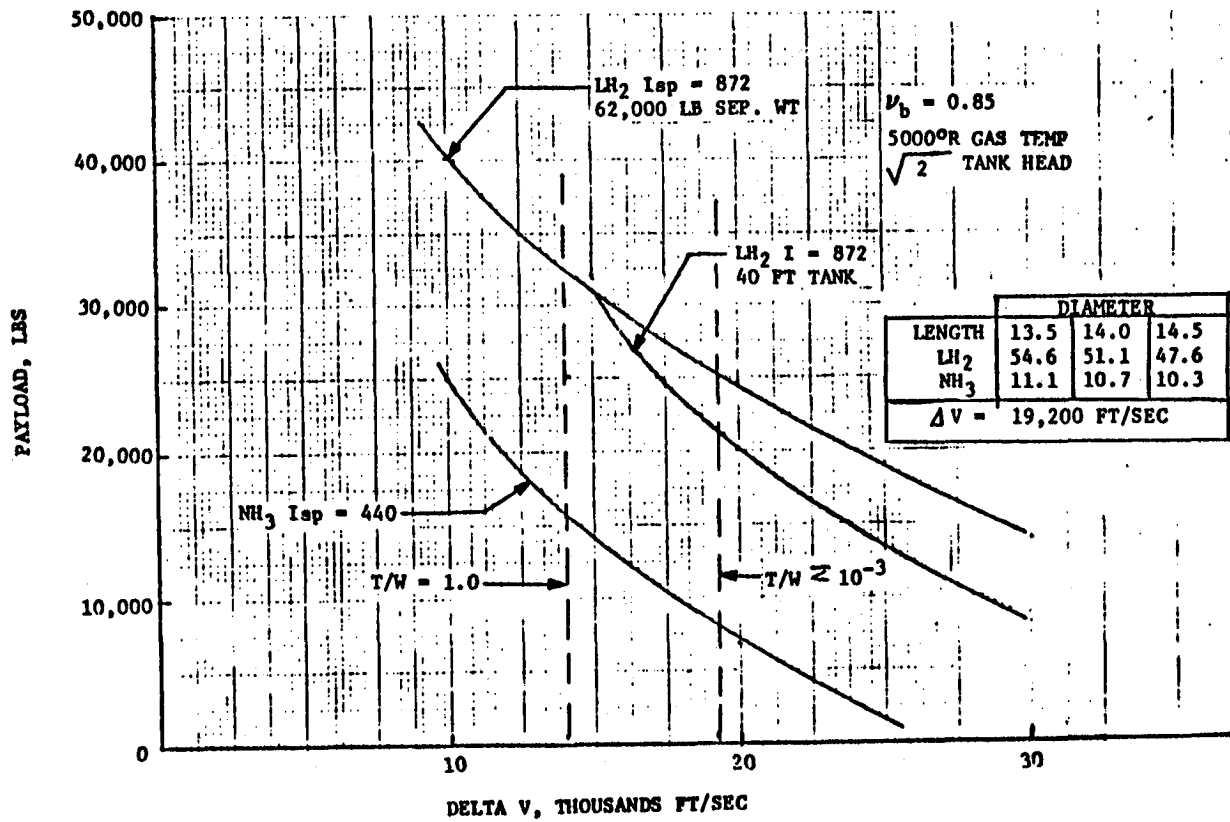

Types of Transfer Maneuvers

The basic mission identified earlier consists of transferring a payload from LEO to GEO. Depending on the thrust-to-weight ratio of the orbit transfer vehicle, the transfer maneuvers can be generally divided into three distinct types. The mission velocity requirements range from a low of 14,000 fps to a high of 19,200 fps, depending on the vehicle thrust-to-weight ratio of the orbit transfer vehicle. It is recognized that continuous thrusting is not possible in low earth orbit due to eclipse periods. The descriptor "continuous" should be interpreted to mean that thrusting occurs whenever solar energy is available. In previous studies, it was found that the inclusion of the time spent traversing the Earth shadow results in a trip-time increase of approximately 10 percent at no increase in propellant expended.

A viable alternative to the classical continuous burn spiral transfer method is to perform the burns only in the vicinity of perigee and/or apogee. Theoretically, with an infinite number of impulses, it should be possible to reduce the required mission velocity to that attained from purely impulsive burns.

TYPES OF TRANSFER MANEUVERS

TWO IMPULSE

ONE PERIGEE BURN
ONE APOGEE BURN

$T/W > 0.01$

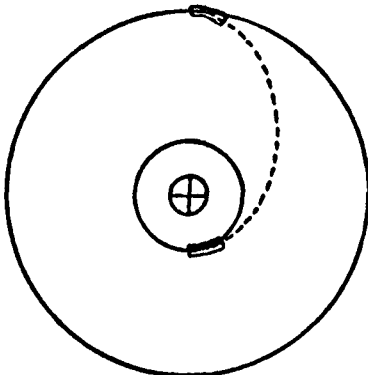

LEO TO GEO

$14000 \leq \Delta V \leq 17000$ FPS
TRIP TIME < DAY

MULTI IMPULSE

MORE THAN ONE PERIGEE
BURNS AND MORE THAN
ONE "INSERTION" BURNS
NEAR FINAL APOGEE

$T/W < 0.1$

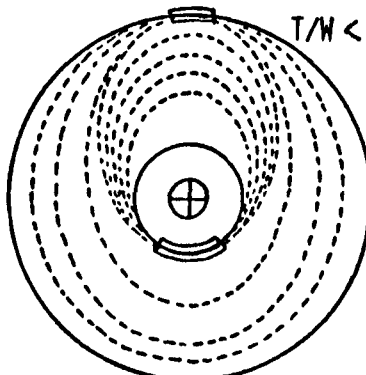

LEO TO GEO

$14000 \leq \Delta V \leq 19200$ FPS
TRIP TIME > DAYS

CONTINUOUS BURN

SPIRAL TRAJECTORY

$T/W < 0.001$

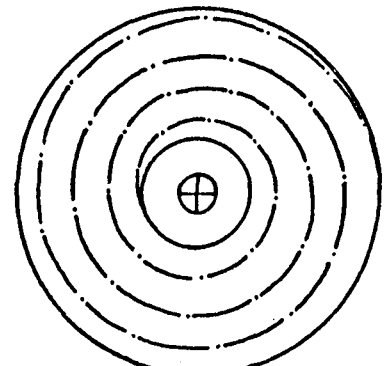

LEO TO GEO

$\Delta V \approx 19200$ FPS
TRIP TIME > DAYS

Delta V as a Function of Trip Time - LEO to GEO

The relationship between the mission ΔV and corresponding time obtained by optimizing the multiburn transfer is illustrated. The example is for an initial thrust-to-weight of 0.3×10^{-3} g's and two representative specific impulse values (727 and 1000 sec). Thus, for example, by extending the transfer from 14 days to 30 days, the mission ΔV can be reduced from 19,200 fps to 16,500 fps (Isp = 727 sec). These trip time increases should, however, be considered in relationship to the 180+ trip times that are characteristic of the mercury ion bombardment propulsion systems.

DELTA V AS A FUNCTION OF TRIP TIME - LEO TO GEO

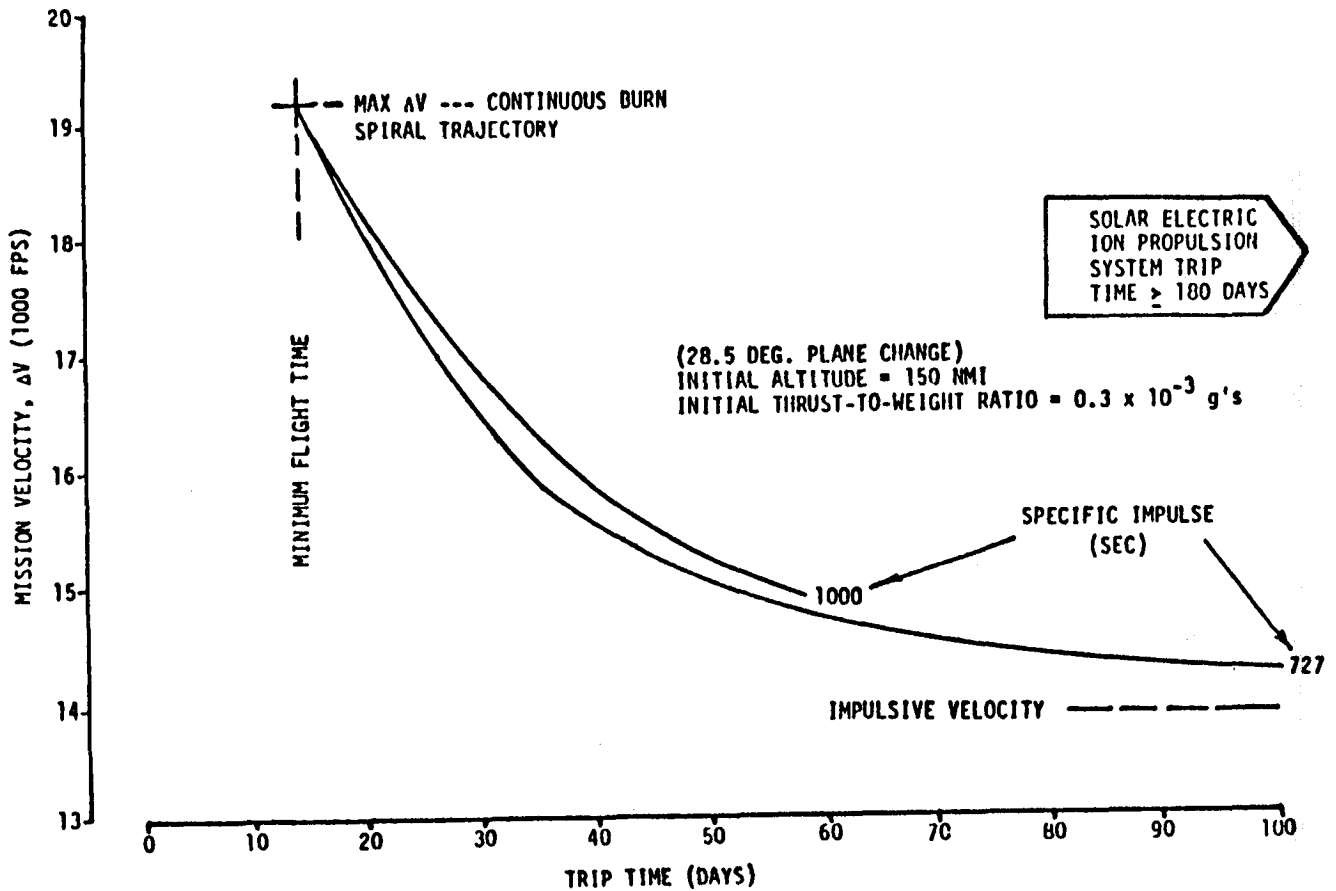

Payload Weight as a Function of Specific Impulse and Mass Fraction (14.5 ft diameter, 40 ft Tank)

To illustrate the effect of trip time, a carpet plot for a one-way 40-day trip, was prepared; this is presented. It may be seen that the 40-day trip time payload is 29,000 pounds ($I = 872$, $\mu_b = 0.85$) and is 8500 pounds greater than for the 14-day case with continuous burn. The decision as to whether an 8500 pound payload increase is desirable in terms of a 26-day increase in trip time must be made by the mission planner.

It is seen that the payload capacity for the higher specific impulses will be limited by the Shuttle separation weight of 62000 pounds for the 40 day mission with the multiple impulsive trajectory.

**PAYLOAD WEIGHT AS A FUNCTION OF SPECIFIC IMPULSE AND MASS FRACTION
(14.5 FT DIAMETER, 40-FT TANK)**

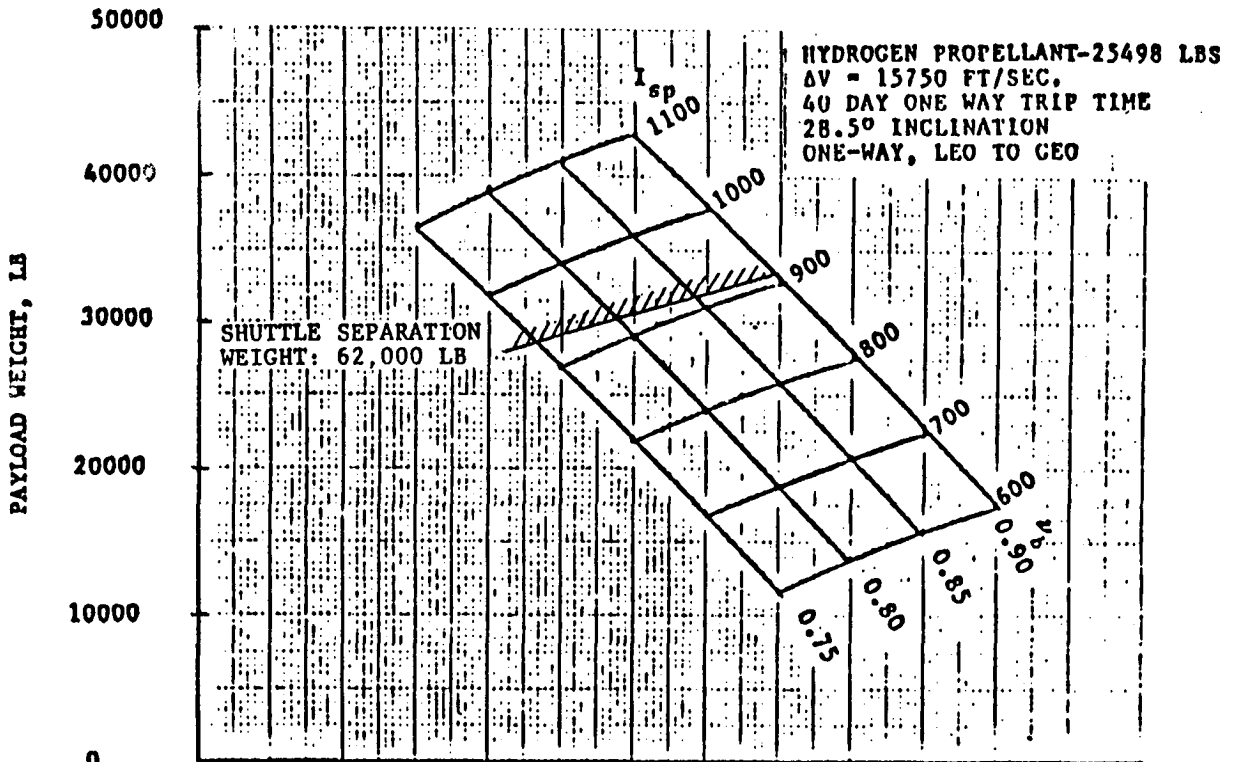

Off-Axis Paraboloid Concentrator Configuration

The basic operating principal of the solar rocket is the use of solar energy to heat a working fluid. The solar collector concentrates the energy through the absorber's window wherein the working fluid is heated to temperatures in excess of 5000°R and the hot gases are expelled via the thruster nozzles.

The primary requirements of a solar collector for a solar rocket system are deployability, low specific mass, and high concentration ratio. The latter is necessary to achieve high temperature and specific impulse of the heated propellant. Of the various candidates considered, only an inflated, non-rigidized concentrator design meets these requirements. The pressure required to maintain the surface contour accuracy is extremely low that any likely puncture of the collector membrane by micrometeoroids encountered during the transfer mission, will allow relatively small volume of gas to escape. (about 200 pounds/mission).

The solar tracking and tangential thrusting can be accomplished by providing a single degree of rotation of the parabolic collectors about an axis normal to vehicle's center line and the second degree is obtained by rotation of complete vehicle about its roll axis.

OFF-AXIS PARABOLOID CONCENTRATOR CONFIGURATION

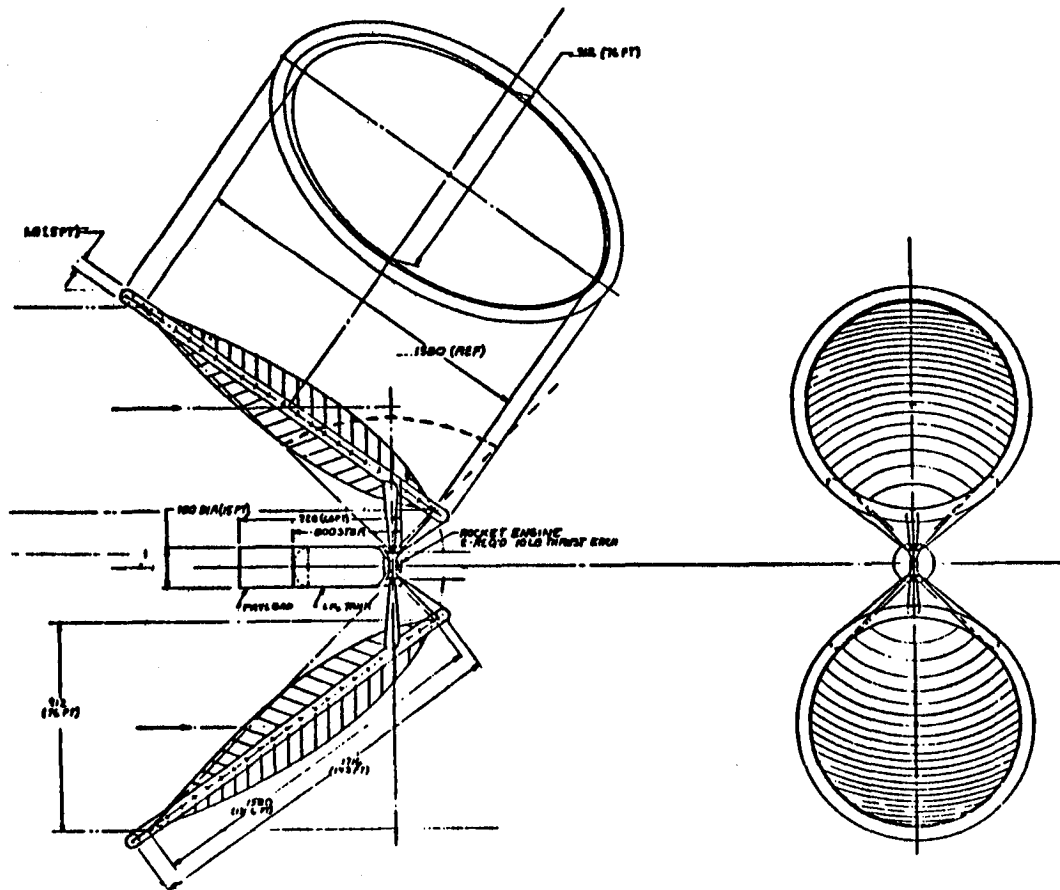

Inflatable Cone/Paraboloid Collector

Design concept is a high thrust vehicle with a paraboloid collector of higher concentration ratio. The inflatable mirror surface is a segment of a paraboloid, while the interior surface is an inflatable cone segment.

INFLATABLE CONE/PARABOLOID COLLECTOR

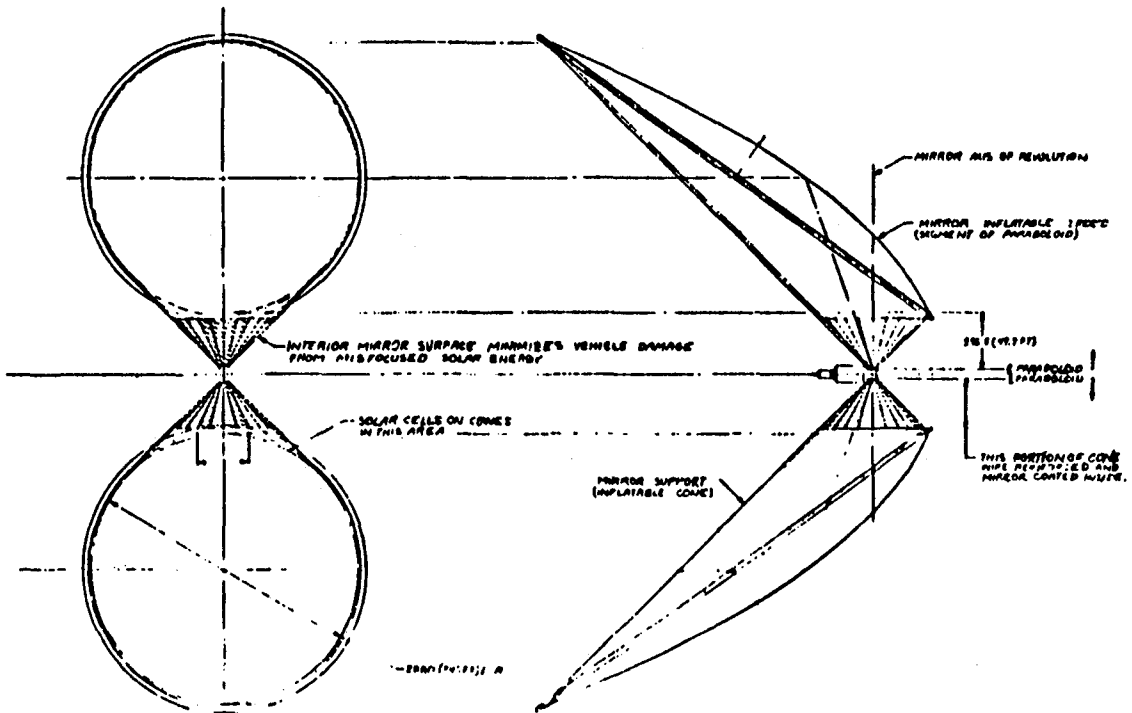

Theoretical Vacuum Specific Impulse Variation with Gas Temperature for Hydrogen, Hydrazine, Ammonia and Methane

The variation of theoretical equilibrium (shifting) vacuum specific impulse with gas temperature was determined for H_2 , CH_4 , NH_3 , and N_2H_4 at a chamber pressure of 50 psia, as shown. Data for thruster nozzle area ratios ranging from 100 to 400 are presented. For a given propellant gas temperature, H_2 achieved a theoretical specific impulse a factor of two higher than that of NH_3 or N_2H_4 and approximately 77-percent higher than of CH_4 . The increase in slope of specific impulse versus temperature with hydrogen at approximately $5000^\circ R$ is the result of an increase in the amount of dissociated hydrogen. Methane specific impulse values for a given temperature were 14 to 24 percent higher than that of NH_3 . As shown, the variation of theoretical specific impulse for an area ratio increase from 100 to 400 was approximately six percent at $7000^\circ R$ gas temperature for H_2 .

The desired high propellant temperatures represent a problem for CH_4 . Above $1760^\circ R$, CH_4 starts to decompose and forms coke, which deposits on coolant passage walls. This coking layer acts as an insulating layer and makes cooling of the heated surface difficult. Therefore methane was not considered a potentially attractive propellant for the solar rocket.

**THEORETICAL VACUUM SPECIFIC IMPULSE VARIATION
WITH GAS TEMPERATURE FOR HYDROGEN, HYDRAZINE,
AMMONIA AND METHANE**

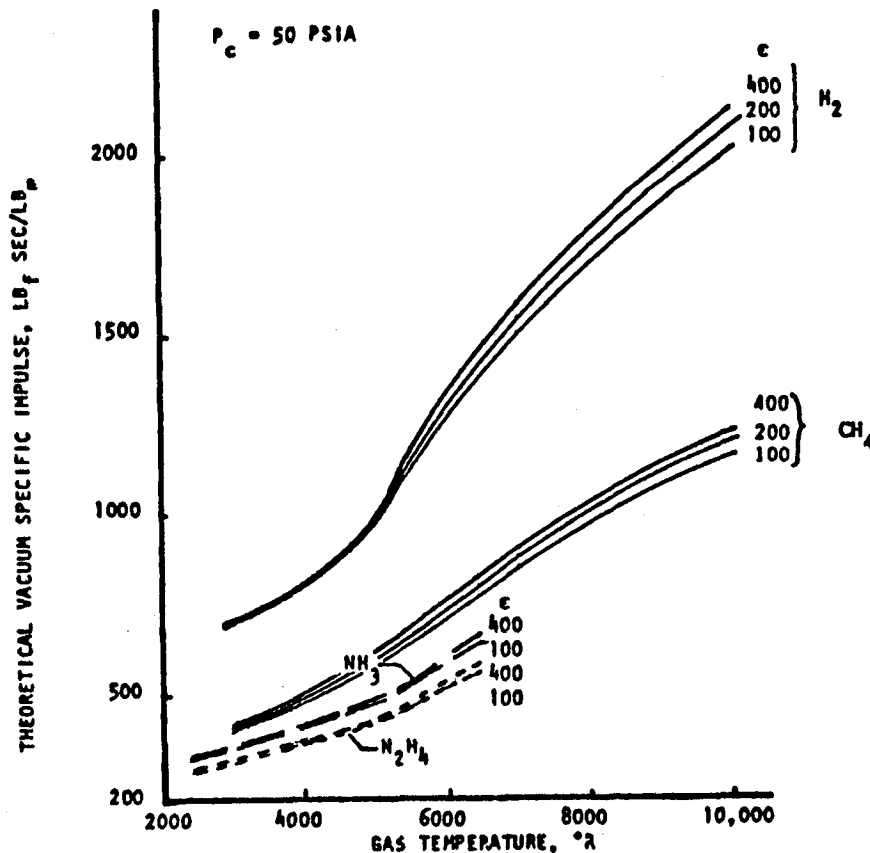

Heat Exchanger Cavity Absorber/Thruster (Two Thrusts) (Hydrogen at 5000°R)

A heat exchanger cavity absorber/thruster configuration with hydrogen at 5000°R (highest performance) consists of a reflector cone (Winston horn) with a 7.2-inch-diameter inlet, an 8-inch-diameter sphere to absorb the reflector cone magnified heat flux, and a 36-inch-diameter annular disc absorber. This sphere/horn/disc absorber configuration can achieve a 71-percent overall efficiency. The two thruster, two absorber configuration at a chamber pressure of 50 psia will deliver a specific impulse of 861 lb f/sec and a thrust of 43 lbf/ The nozzle exit is placed at the same plane as the edge of the flat disc to prevent plume impingement on the disc absorber.

**HEAT EXCHANGER CAVITY ABSORBER/THRUSTER (TWO THRUSTERS)
(HYDROGEN AT 5,000°R)**

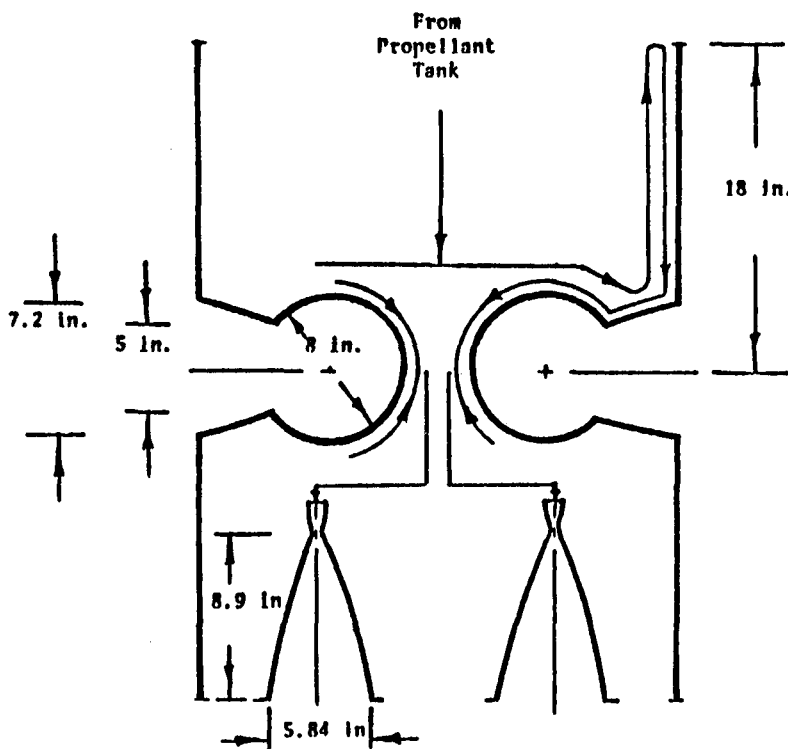

Collector:

Number: Two
 Diameter: 100 ft
 Efficiency: 80-percent
 Surface Angular Error: 1/4-degree

Absorber:

Spherical/ Horn/Disc
 Disc Diameter: 36-in.
 Horn Inlet r: 3.6-in.
 Sphere Diameter: 8-in.
 ϵ_{sphere} : 0.3
 ϵ_{disc} : 0.9
 Efficiency: 71-percent

Thruster:

Throat Diameter: 0.584-in.
 Area Ratio: 100-to-1
 Chamber Pressure: 50 psia
 Flowrate: 0.025 lb/sec each
 Thrust: 21.5 lb_f each
 Specific Impulse: 861 lb_f sec/lb_m

HYDROGEN HEAT EXCHANGER ABSORBER/THRUSTER PERFORMANCE

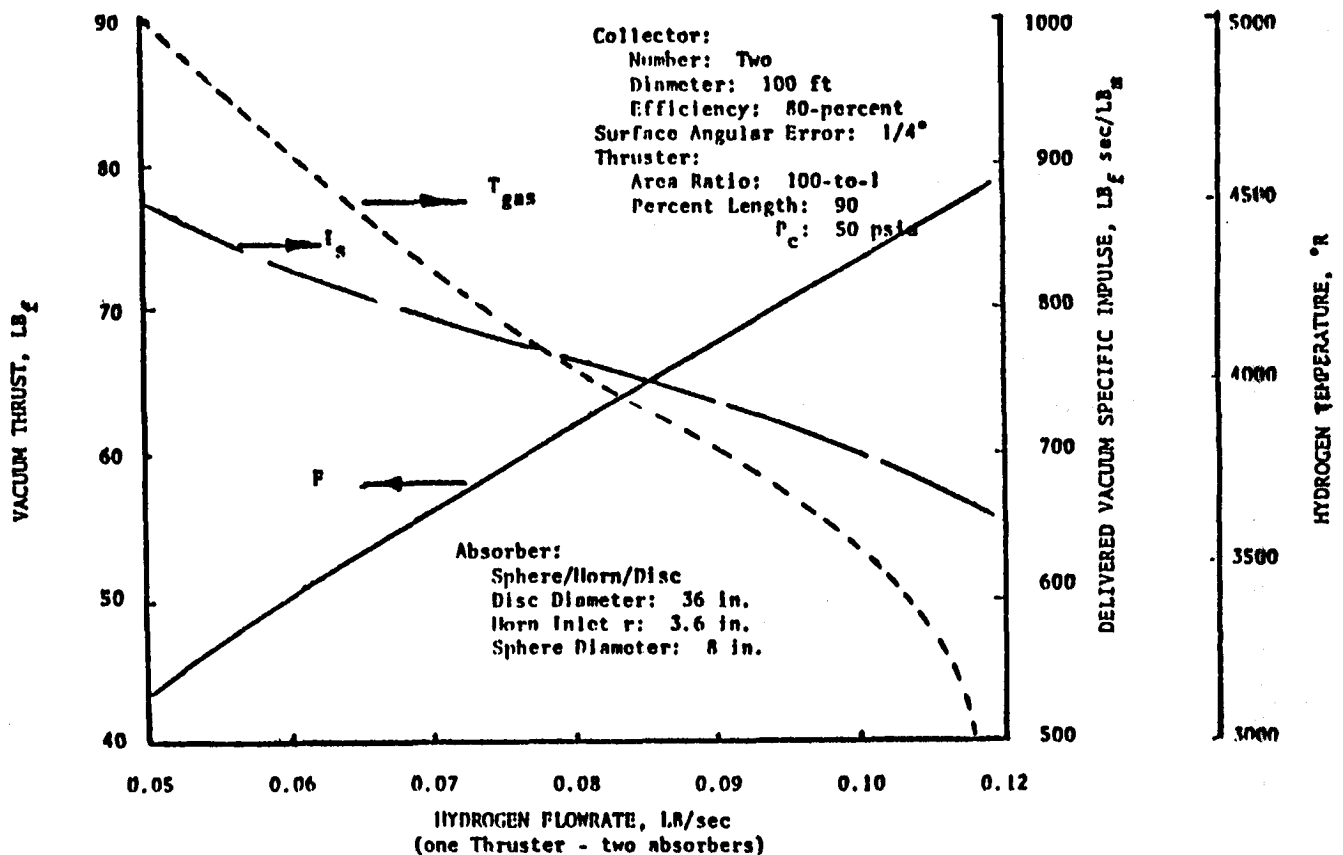

Particulate Absorber/Thruster (Hydrogen/Carbon at 7000°R)

A similar system as analyzed with a 100-to-1 area ratio, 90-percent length bell nozzles with two 100-foot-diameter collectors and using Hydrogen/carbon (10-percent) as the propellant. For the 6000°R-to-8000°R propellant temperature range evaluated, the delivered specific impulse varied from 940 lb_f sec/lb_m to 1100 lb_f sec/lb_m for the H₂/C propellant with a carbon mass fraction of 0.1. The thrust decreased from 23.5 lb_f to 9 lb_f as the propellant temperature was increased from 6000 to 8000°R.

A particulate absorber/thruster configuration with H₂/C at 7000°R consists of a 6-inch-radius cylinder plus an annular disc. Hydrogen first cools the annular disc absorber, then splits (1) to cool the solid window and (2) to cool the thruster and absorber body. Once the absorber body is cooled, the H₂ enters a solid-particle gas mixer, and the H₂C mixture is injected downstream of the window. The cylindrical particulate absorber/disc configuration achieved a 51-percent overall efficiency using the optimistic absorber analysis approach the single thruster at a chamber pressure of 50 psia resulted in a delivered specific impulse of 1041 lb_f sec/lb_m and thrust of 14 lb_f.

PARTICULATE ABSORBER/THRUSTER (HYDROGEN/CARBON AT 7000°R)

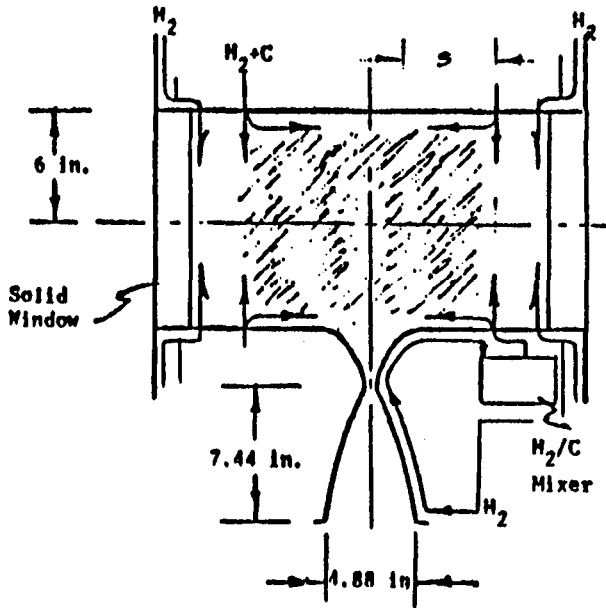

Collector:
 Number: Two
 Diameter: 100 ft
 Efficiency: 80-percent
 Surface Angular Error: $1/8$ -degree

Absorber:
 Cylindrical Particulate/Thruster/
 Disc

c_{gas} : 1.0

c_w : 0.1

η_w : 0.9

Efficiency: 51-percent

Thruster:

Throat Diameter: 0.489 in.

Area Ratio: 100-to-1

Chamber Pressure: 50 psia

C_c : 0.1

Flowrate: 0.013 lb/sec

Thrust: 14 lb_f

Specific Impulse: 1041 $lb_f \text{ sec} / lb_m$

HYDROGEN/CARBON PARTICULATE ABSORBER/THRUSTER PERFORMANCE

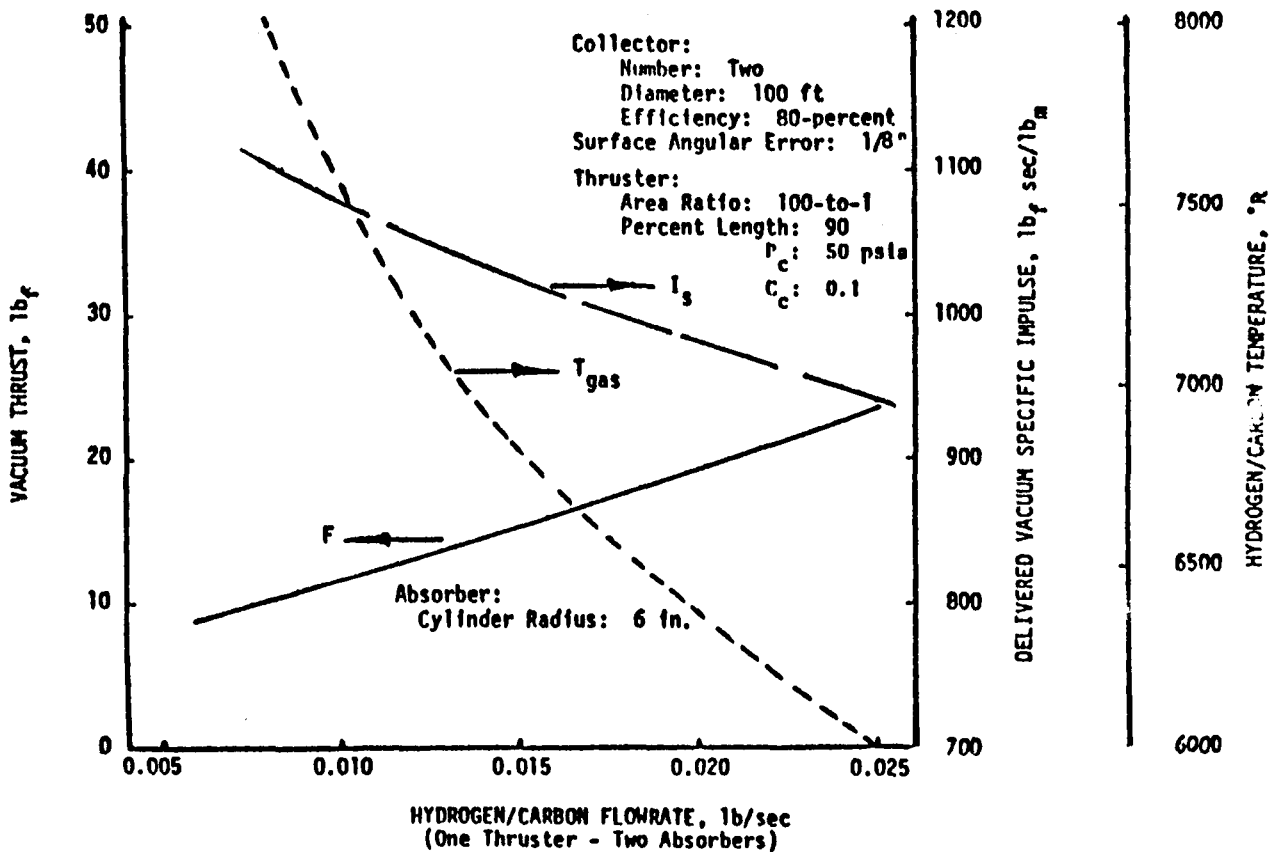

Required Concentrator Diameter

The diameter of the solar collector is dependent on the thrust level required and the concentration ratio necessary to attain the desired cavity temperatures. Based on collector efficiency of 80% and a RMS surface error of 1/8 the required diameter for each collector is shown in this chart.

REQUIRED CONCENTRATOR DIAMETER

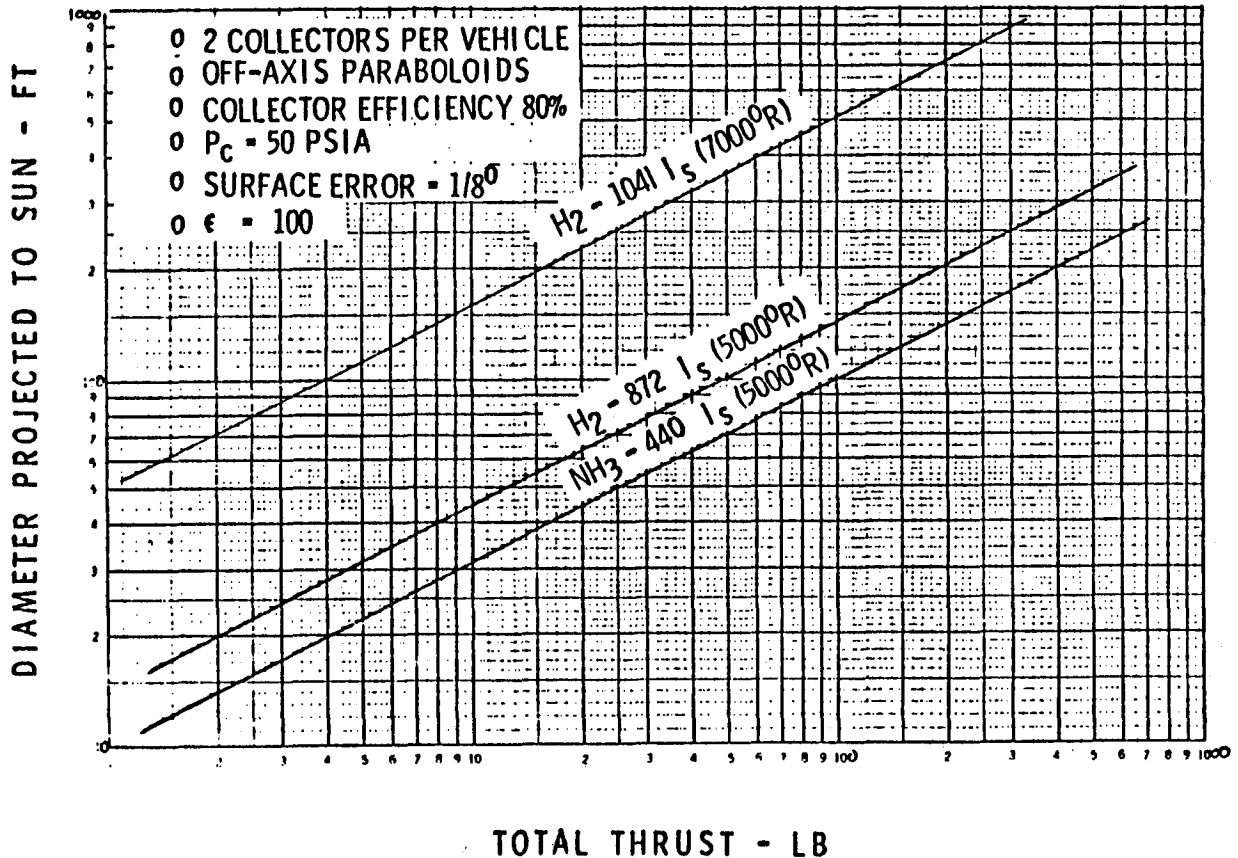

Sundstrand/Goodyear Collector Experience

During the mid 1960 several light weight collectors were fabricated to determine collector surface accuracy and performance.

The 44.5 foot-diameter concentrator built under the ASTEC program used a foam rigidized aluminized mylar concept which demonstrated a concentration ratio of 3200. The contour accuracy was within ± 0.25 inch (equivalent to $\pm 0.10^\circ$ surface error standard deviation). Subsequent analysis of the concentrator indicated that the foam caused distortions in the concentrator surface which caused a reduction in the potentially available concentration ratio. The estimated concentration ratio used in the study was 9800. Through the use of Winston horn (compound parabolic reflector skirt), an average concentration ratio at the exit of the horn of 14328 is expected.

SUNDSTRAND/GOODYEAR COLLECTOR EXPERIENCE

- SUNDSTRAND WAS CONTRACTOR IN MID-1960's FOR PROJECT ASTEC (15 KW SOLAR POWER SYSTEM)
- CONCENTRATOR WAS SUBCONTRACTED TO GOODYEAR
- INFLATED AL-MYLAR, FOAM RIGIDIZED DESIGN
- 10 FT. DIA. MODEL - 3900 C.R.
- 44.5 FT. DIA, MODEL - 3200 C.R.
- CONTOUR ACCURACY OF 44.5 FT. MODEL WAS WITHIN $\pm 0.25"$ (EQUIVALENT TO $<\pm 0.1^\circ$ SURFACE ERROR STD. DEVIATION)
- SUNDSTRAND SAYS NON-RIGIDIZED DESIGN IS MUCH BETTER THAN RIGIDIZED FOR HIGH ACCURACY MIRRORS.
- INDICATIONS ARE THAT $1/8^\circ$ SURFACE ERROR CAN BE ACHIEVED IN SPACE (SEARCHLIGHT QUALITY)

SOLAR ROCKET SYSTEM SHUTTLE LAUNCH INSTALLATION

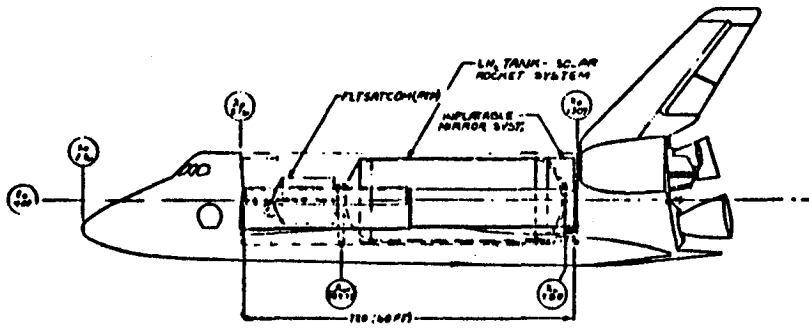

SIDE VIEW

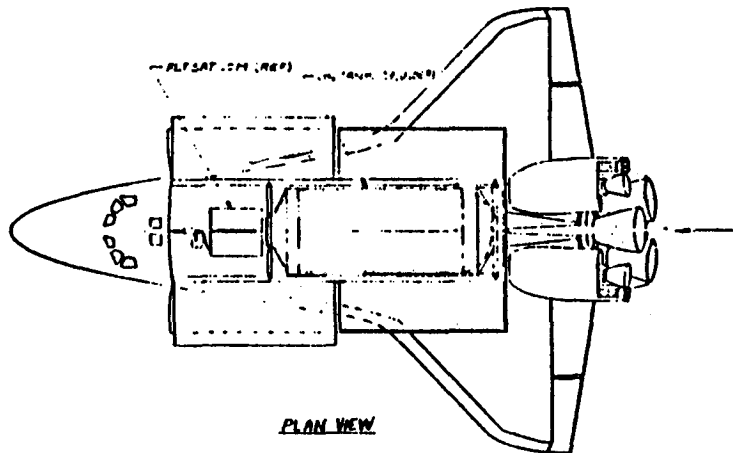

PLAN VIEW

Parametric Synthesis

The parametric analysis of the solar rocket system was achieved using the Solar Thermal Orbital Propulsion—Computerized Unmanned Spacecraft Synthesis program (STOP CUSS). This program allows the investigation of various design and subsystem parameters and how these parameters affect the overall vehicle performance.

The major structural elements of the propulsion stage are the propellant tankage, the solar collector components, and the thruster system. Weight allowances must be assigned to each of these major elements to account statistically for the secondary structure and ancillary equipment. Each of the structural components is divided into its element models, each element is defined analytically, and a preliminary design synthesis is conducted on the individual elements to identify minimum weights and scaling laws for feasible designs. A correlation factor (non-optimum weight, etc.) is applied to these laws based on historical data pertinent to the type of material, construction, and complexity of the component.

The synthesis approach starts with the sizing of the tanks to contain the propellant used for propulsive changes in the vehicle's orbit (LEO to GEO, etc) and the propellant that will boil-off during the longer trip times. The heating rate and total heat input throughout the various mission trajectory segments will influence the propellant boiled-off.

The quantity of propellant boil-off is a function of the vehicle's thrust-to-weight (hence trip time), the surface area of the tank(s) exposed to the thermal environment, and the tank insulation concepts. Sizing and number of propellant tanks employed for the large payload designs are dictated by the Shuttle orbiter's cargo bay physical limitations.

PARAMETRIC SYNTHESIS

SOLAR THERMAL ORBITAL PROPULSION COMPUTERIZED UNMANNED SPACECRAFT SYNTHESIS (STOP CUSS)

EFFECTS OF:

- o PAYLOAD SIZE
- o INSULATION THICKNESS
- o THRUST-TO-WEIGHT
- o SPECIFIC IMPULSE
- o SHUTTLE CONSTRAINTS
- o MISSION TRIP TIME
- o TANK PRESSURES

Effect of Insulation Thickness

Results show that for the LEO-GEO and LEO-GEO and return trips the Multilayer insulation should be about 1.5 inches thick to preclude too much hydrogen boil-off during the multi-day trip time.

EFFECT OF INSULATION THICKNESS

SPECIFIC IMPULSE = 1041 SECS

T/W = 0.00003

LEO - GEO

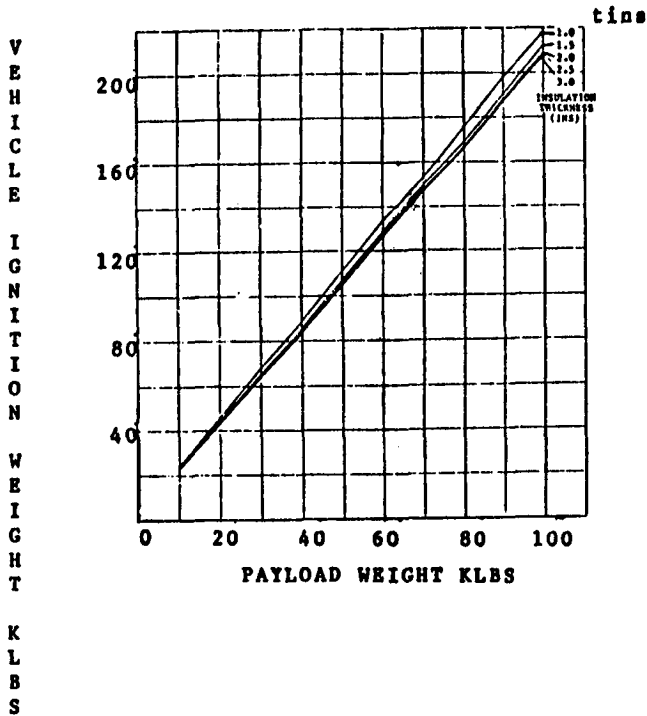

LEO - GEO & RETURN

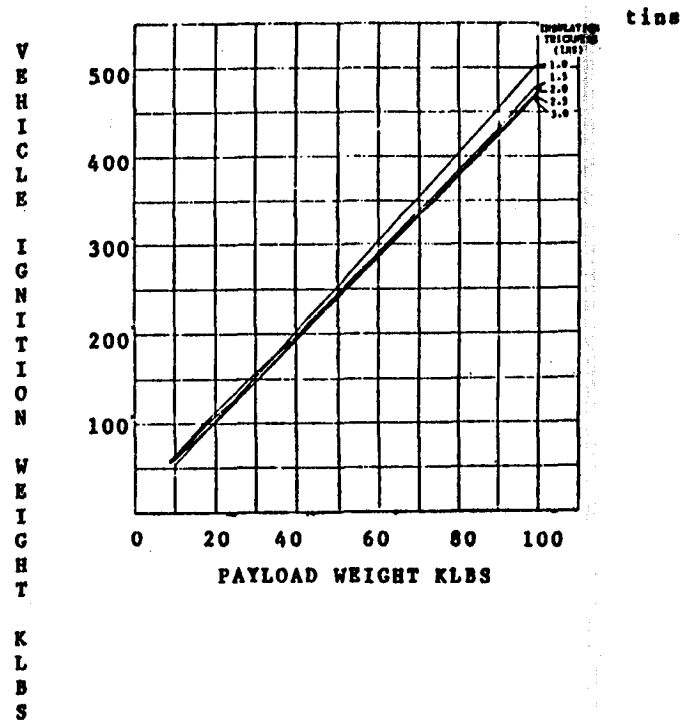

Effect of Thrust-to-Weight for LEO-GEO and Return

It is interesting to note that for the low specific impulse (872 sec) system that payload performance is improved by increasing the T/W from 0.5 to 3.0×10^{-4} . For the higher specific impulse (1041 secs) the opposite is true. There can be significant decreases in payload performance for the higher T/W at the larger payload ranges. This is due to the larger size solar collectors required to obtain the 7000°R temperatures, wherein the collector weight becomes a significant percent of the stage empty weight.

EFFECT OF THRUST TO WEIGHT FOR LEO-GEO AND RETURN

SPECIFIC IMPULSE 872 SEC

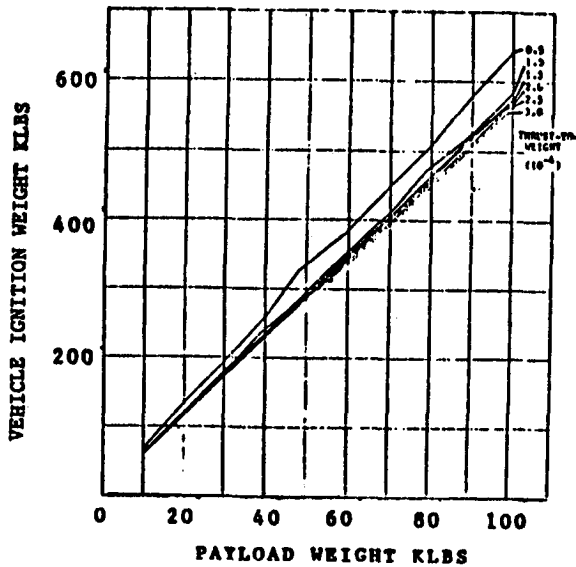

SPECIFIC IMPULSE 1041 SEC

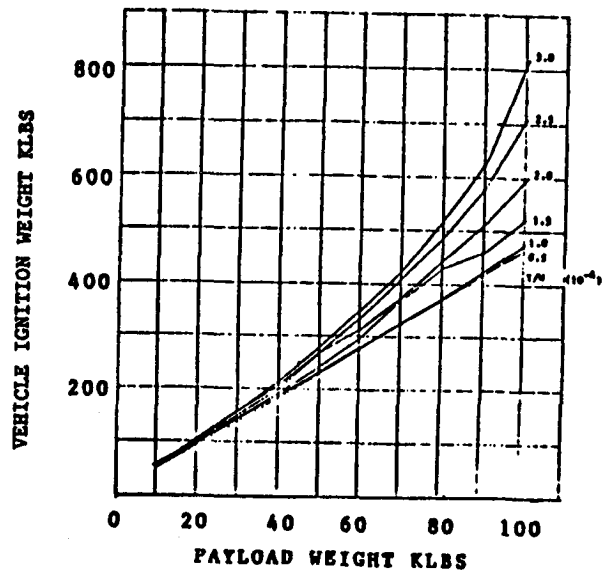

Effect of Improved Engine Performance

This chart shows the vehicle initial launch weight required for payloads ranging from 10,000 lbs to 100,000 lbs. Three missions are considered, these being, expendable LEO to GEO, recoverable LEO-to-GEO thirty days stay at GEO and then return only the vehicle stages and thirdly the mission which recovers both the stage and a payload with a thirty day stay at GEO.

EFFECT OF IMPROVED ENGINE PERFORMANCE

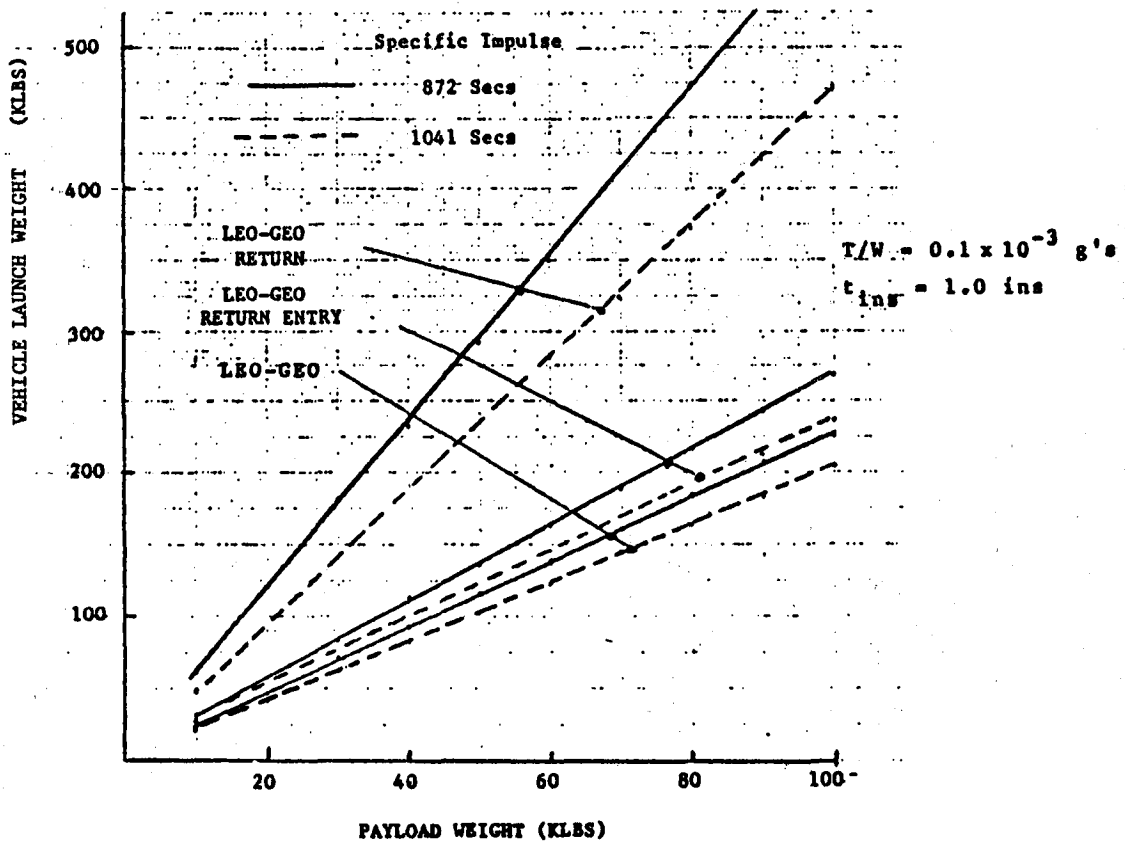

Single Orbiter Launch Capability

The single Shuttle launch payload capability increases as the trip duration increases. The trajectories considered for these increased flight times are for the apogee/perigee burn flight modes which significantly reduced the total velocity requirements. The velocity required is 19,200 ft/sec at the 14-day trip time reducing to 15,750 ft/sec for the 40-day duration. The extended mission duration has the effect of increasing the amount of propellant boiled-off, which negates some of the benefits of the reduction in velocity requirements.

For the LEO-to-GEO mission, the payload delivered by an orbiter launch vehicle ranges from 22,000 to 27,000 pounds for the low-temperature (5000°R) thruster system. This payload can be increased by 20 percent if the high-temperature (7000°R) thruster is used for the propulsion system.

Missions which return the vehicle but leave the payload at GEO can place payloads of from 15,000 to 20,000 pounds into the geosynchronous orbit. This type of mission does not benefit from the improved thruster performance of the high-temperature system. The payload is very sensitive to the returned stage inert weight. The collector weight for the high-temperature system constitutes a significant percentage of the stage inert weight and negates the gains from the higher impulse.

SINGLE ORBITER LAUNCH CAPABILITY

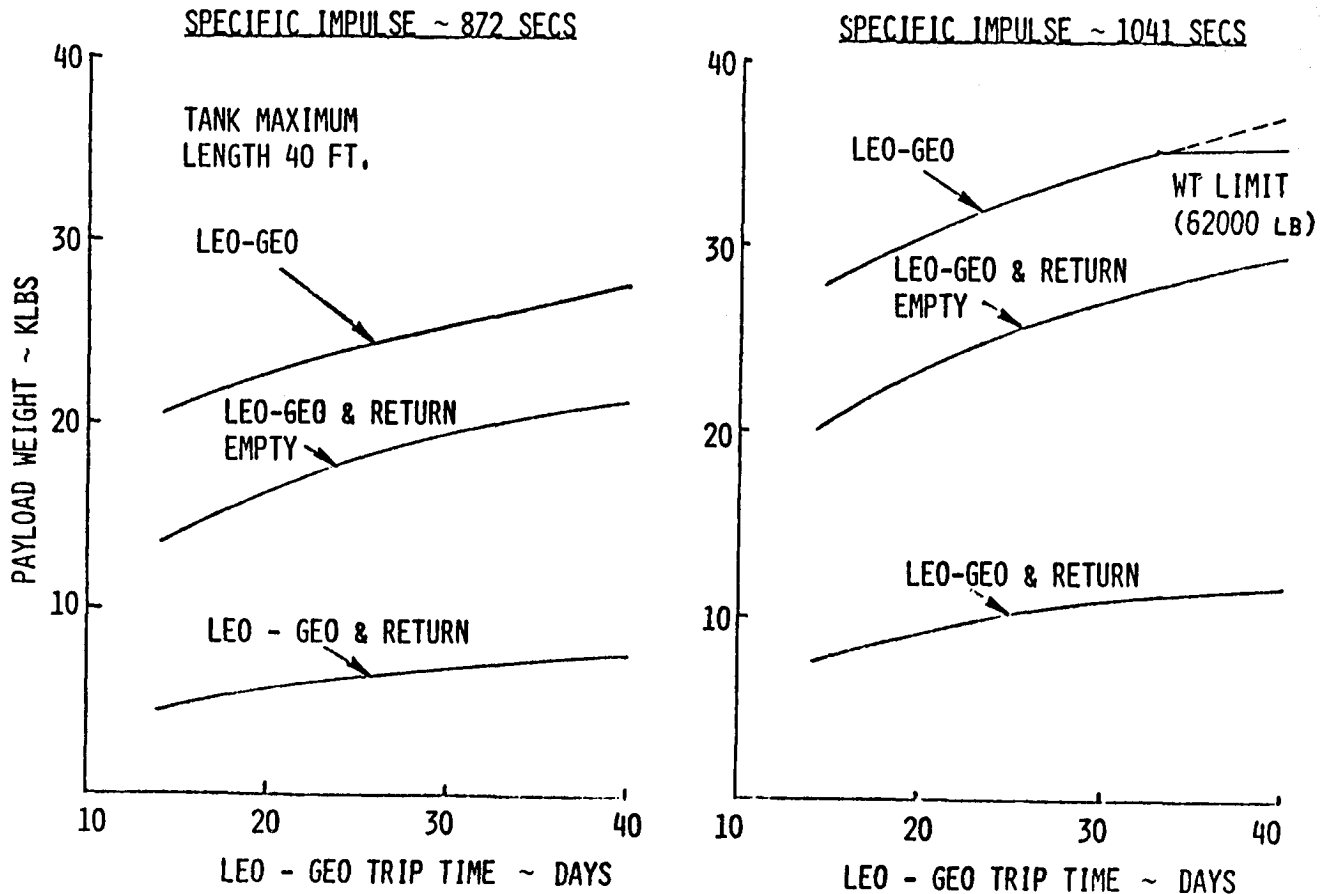

EFFECT OF TANK PRESSURE

SPECIFIC IMPULSE 872 SECS

T/W = 0.0003 G'S

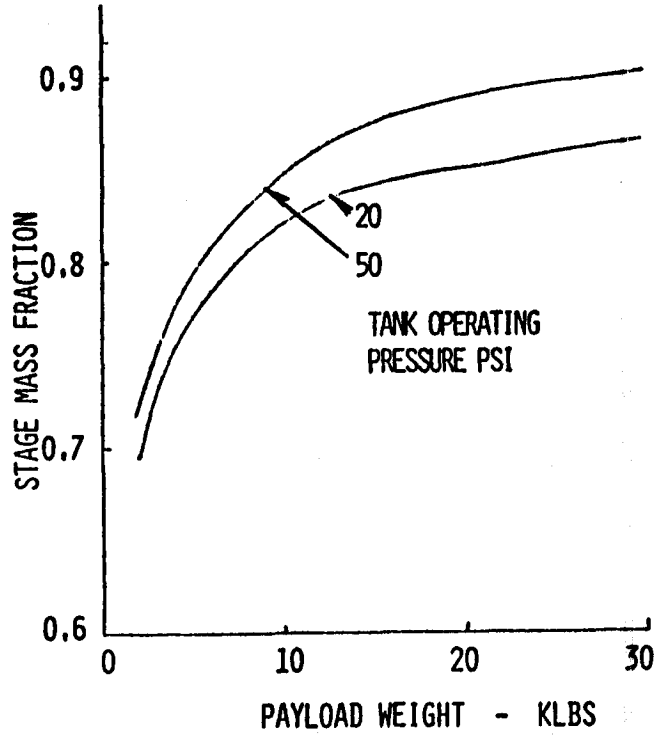
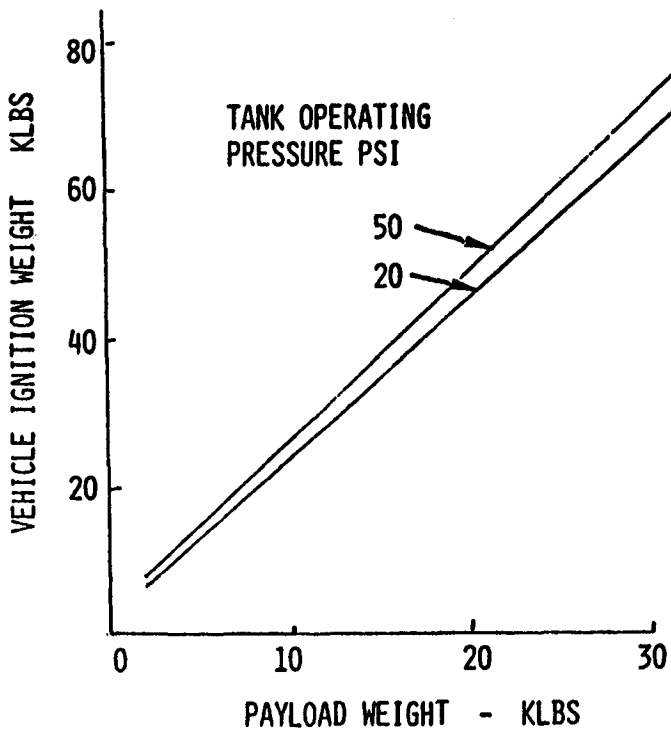

Technology Development Areas

Although there appears to be performance improvements with the high temperature system (7000°R) there are several major technical development areas to be investigated. The propellant is carbon doped hydrogen which will tend to deposit on the absorber's window and hence reduce the energy entering the absorber's cavity, thus cutting down its thermal efficiency. A film of hydrogen across the inside of the window could possibly reduce the deposition problem. The higher temperatures are pushing even further the material requirements, while the solar collector is larger than the 5000°R system with equal thrust levels.

The inflatable collectors with their high concentration rates although ground test articles have been fabricated, their packaging and automated deployment in space present areas of untested technology. The multiple-burn trajectory with its coast periods between burns will require a defocusing of the collector.

TECHNOLOGY DEVELOPMENT AREAS

THRUSTERS

- INCREASE PERFORMANCE - HIGHER TEMPERATURES
- AVOIDANCE OF CARBON DEPOSITION

COLLECTORS

- COLLECTOR OPTIMIZATION (FACETS, DESIGN, C.G.)
- NON-UNIFORM STRESS OF PARABOLOIDAL MEMBRANE
- HIGH ACCURACY COLLECTOR FABRICATION TECHNIQUES
- SPECULAR REFLECTANCE OF METALIZED FILMS
- STRUCTURAL DYNAMICS & THERMAL DEFORMATIONS
- DEFOCUSING DURING COAST PERIODS

TANKAGE

- PUMP-FED VS. PRESSURE-FED PROPELLANTS
- HIGH PERFORMANCE INSULATION DESIGN

CONTROL

- OPTIMUM STEERING POLICY
- C.G. SHIFTING WITH TRACKING
- GIMBALED ENGINES VS. RCS JETS

Conclusions

The solar rocket system presents an interesting alternative whose performance is between the best chemical and the electric propulsion system. The thrust-to-weight is about 10^{-3} which would make them attractive as propulsion systems for large flexible space structures.

CONCLUSIONS

- THE 5000⁰R SOLAR ROCKET SYSTEM IS WITHIN THE CURRENT STATE-OF-THE-ART
- THE 5000⁰R SOLAR ROCKET SYSTEM PERFORMANCE IS SUPERIOR TO AN LO₂-LH₂ ORBIT TRANSFER VEHICLE FOR MULTI-DAY TRANSIT TIMES
- THE PAYLOAD OF THE 5000⁰R SOLAR ROCKET FOR THE PAYLOAD-UP SPACECRAFT DOWN CASE IS GREATER THAN THE CHEMICAL SYSTEM.
- THE 7000⁰R SOLAR ROCKET SYSTEM WILL REQUIRE A SIGNIFICANT DEVELOPMENT EFFORT BUT THE PAYOFF FOR THE SINGLE SHUTTLE LAUNCH CASE IS SIGNIFICANT.
- SOLAR ROCKET HAS POTENTIAL FOR HIGHER ENERGY ORBIT TRANSFER AT LOWER THRUST-TO-WEIGHT RATIOS USING EFFICIENT MULTI-DAY TRANSIT MANEUVERS