

NEWTON'S METHOD: A LINK BETWEEN CONTINUOUS AND  
DISCRETE SOLUTIONS OF NONLINEAR PROBLEMS

Gaylen A. Thurston  
Langley Research Center

ABSTRACT

Newton's method for nonlinear mechanics problems replaces the governing nonlinear equations by an iterative sequence of linear equations. When the linear equations are linear differential equations, the equations are usually solved by numerical methods. The iterative sequence in Newton's method can exhibit poor convergence properties when the nonlinear problem has multiple solutions for a fixed set of parameters, unless the iterative sequences are aimed at solving for each solution separately. The theory of the linear differential operators is often a better guide for solution strategies in applying Newton's method than the theory of linear algebra associated with the numerical analogs of the differential operators. In fact, the theory for the differential operators can suggest the choice of numerical linear operators. In this paper the method of variation of parameters from the theory of linear ordinary differential equations is examined in detail in the context of Newton's method to demonstrate how it might be used as a guide for numerical solutions.

INTRODUCTION

Nonlinear mechanics problems can be formulated as nonlinear differential equations and associated boundary conditions. One approach to solving these nonlinear equations is Newton's method. Newton's method replaces the nonlinear equations with an iterative sequence of linear differential equations. The present paper emphasizes that each iteration step consists of two separate operations. The first operation, referred to as linearization, is the derivation of the linear differential equations. The second operation is the solution of the linear equations and is referred to by the name of the method of solution for the linear system (e.g., power series, asymptotic series, finite-differences, finite-elements, successive approximations, or boundary integrals).

The emphasis on defining the iteration in Newton's method as two successive operations is to prevent confusion between Newton's method and the familiar Newton-Raphson method for a set of nonlinear algebraic equations. The confusion arises when the second operation is purely numerical and depends on a discretization operation. In this case, the operation of discretization can be applied to the nonlinear differential operators followed by the linearization of the Newton-Raphson method. Ortega and Rheinboldt, (ref. 1), prove that the operations of linearization and discretization commute. The operations

result in the same set of linear algebraic equations for each iteration step for both the Newton-Raphson method and Newton's method. The proof that the two operations commute requires that "the discretizations are carried out in the same way."

The present paper examines problems where the discretizations are not carried out in the same way. The choice of discrete model is affected by the theory of the linear differential equations. Examples of these problems are boundary-value problems where multiple solutions exist for a fixed set of parameters. This class of problems includes periodic solutions of nonlinear dynamics problems and static buckling problems with bifurcation points and with limit points.

Newton's method, that is, the operation of linearization before discretization, supplies two kinds of information for problems with multiple solutions. The first kind is qualitative information which is related to the convergence of the iterative procedure and is useful in itself. The second kind of information is quantitative information that directly affects the discrete model. The literature for linear differential equations is vast and much of it provides insight into the convergence properties of Newton's method. Rather than attempting a general review of applicable theory, this paper examines one method in detail as it relates to Newton's method. The method examined is variation of parameters as it is applied to systems of ordinary differential equations. The theory is examined first, followed by a discussion of the application of the theory to discrete solutions of nonlinear problems with multiple solutions.

The main body of the paper on variation of parameters is preceded by a preliminary section. This section discusses the linearization operation in Newton's method. Once the equations are linearized, different versions of Newton's method receive different names in the literature. These versions are briefly reviewed. The section also discussed convergence of Newton's method as it pertains to nonlinear problems with multiple solutions. The theoretical results from variation of parameters suggest changes in dependent variables that are determined by the given problem and, therefore, are applicable to adaptive computer solutions. A final section indicates the general nature of such adaptive computer solutions.

## NEWTON'S METHOD

### Fundamental Concepts

Nonlinear mechanics problems that are formulated as nonlinear ordinary or nonlinear partial differential equations can be solved using Newton's method. The basic idea in Newton's method is to expand the nonlinear operator about an assumed or an approximate solution. This expansion yields a new nonlinear operator that operates on an unknown correction to the approximate solution. It is assumed in Newton's method that nonlinear terms in the correction are small compared to linear terms, and the nonlinear terms are temporarily neglected. The resulting linear differential equations are

solved for an approximate correction which is added to the assumed solution to make a new approximation. The procedure is repeated until the corrections are small. At each iteration step, the residual error in the solution of the nonlinear problem is a function of the nonlinear terms neglected in the previous iteration step. Convergence of the iterative sequence is almost assured if the nonlinear problem has a unique solution. When the nonlinear problem has multiple solutions, convergence is not assured in Newton's method unless provisions are made to converge to only one solution for each iteration sequence. Examples of problems with multiple solutions are static buckling problems with bifurcation points and with limit points and certain nonlinear vibrations problems. The theory of linear differential operators is useful in guiding numerical computations so that Newton's method converges to the desired solution branch.

The linear operator in Newton's method is called the Frechet derivative, and it is derived from the nonlinear differential operator for the problem. Let the nonlinear differential operator be  $P$  operating on a scalar function or vector function  $y$ . The nonlinear problem is

$$P(y) = 0 \tag{1}$$

plus associated initial conditions or two-point boundary conditions. Denote by  $y_m$  the approximation to the solution of equation (1) after the  $m$ th iteration step, and denote by  $\delta y_{m+1}$  the correction to  $y_m$ . Then the Newton iteration process solves recursively the equations

$$P'[y_{m-1}](\delta y_m) = -P[y_{m-1}] \tag{2a}$$

$$y_m = y_{m-1} + \delta y_m \quad m = 1, 2, 3, \dots \tag{2b}$$

The operator  $P'[y_{m-1}]$  in equation (2a) is the Frechet derivative. Formal definitions of the Frechet derivative appear in texts on functional analysis, reference (2). For nonlinear differential operators operating on continuous functions, the Frechet derivative consists of the linear operators that appear in a Taylor series expansion in several variables. The expansion is in terms of the dependent variables rather than the independent variables, reference (3).

#### Examples of Frechet Derivatives

For example, consider a single nonlinear equation.

$$\frac{d^2 y}{dt^2} + C \left( \frac{dy}{dt} \right)^2 + \lambda \sin y - F \sin \omega t = 0 \tag{3}$$

with C,  $\lambda$ , F and w constants. The linear variational equation, equation (2a), for equation (3) is

$$\frac{d^2 \delta y_m}{dt^2} + 2C \left( \frac{dy_{m-1}}{dt} \right) \frac{d \delta y_m}{dt} + \lambda (\cos y_{m-1}) \delta y_m = -P[y_{m-1}] \quad (4a)$$

$$P[y_{m-1}] = \frac{d^2 y_{m-1}}{dt^2} + C \left( \frac{dy_{m-1}}{dt} \right)^2 + \lambda \sin y_{m-1} F \sin wt \quad (4b)$$

The Frechet derivative for the nonlinear operator is the operator

$$P'[y_{m-1}](\delta y_m) = \frac{d^2(\delta y_m)}{dt^2} + 2C \frac{dy_{m-1}}{dt} \frac{d(\delta y_m)}{dt} + \lambda \cos y_{m-1} (\delta y_m) \quad (5)$$

The Taylor series expansion in Newton's method is readily extended to partial differential operators. A second example is a nonlinear strain expression

$$\epsilon_{xz} = \frac{\partial u}{\partial z} + \frac{\partial w}{\partial x} + \frac{\partial u}{\partial z} \frac{\partial u}{\partial z} + \frac{\partial v}{\partial x} \frac{\partial v}{\partial z} + \frac{\partial w}{\partial x} \frac{\partial w}{\partial z} \quad (6)$$

Then

$$\begin{aligned} \epsilon'_{xz}[y_{m-1}](\delta y_m) &= \frac{\partial \delta u_m}{\partial z} + \frac{\partial \delta w_m}{\partial x} + \frac{\partial u_{m-1}}{\partial x} \frac{\partial \delta u_m}{\partial z} \\ &+ \frac{\partial u_{m-1}}{\partial z} \frac{\partial \delta u_m}{\partial x} + \frac{\partial v_{m-1}}{\partial x} \frac{\partial \delta v_m}{\partial z} + \frac{\partial v_{m-1}}{\partial z} \frac{\partial \delta v_m}{\partial x} \\ &+ \frac{\partial w_{m-1}}{\partial x} \frac{\partial \delta w_m}{\partial z} + \frac{\partial w_{m-1}}{\partial z} \frac{\partial \delta w_m}{\partial x} \end{aligned} \quad (7)$$

In addition to the linear variational equations of Newton's method, the Frechet derivative appears as part of the chain rule of differentiation. If the nonlinear operator is written  $P(y(x),x)$  to emphasize that y is a function of the independent variable, the total derivative of P is

$$\frac{dP}{dx} = P'[y] \left( \frac{dy}{dx} \right) + \frac{\partial P}{\partial x} = 0 \quad (8)$$

The derivative of equation (3) with respect to  $t$  can be written

$$\frac{d^2}{dt^2} \left( \frac{dy}{dt} \right) + 2C \frac{dy}{dt} \frac{d}{dt} \left( \frac{dy}{dt} \right) + \lambda (\cos y) \frac{dy}{dt} = wF \cos wt \quad (9)$$

It is often useful to think of  $y$  as a function of parameters in addition to the independent variables and the operator as  $P(y(\lambda, x), x, \lambda)$ . Then

$$\frac{\partial P}{\partial \lambda} = P'[y] \left( \frac{\partial y}{\partial \lambda} \right) + \dot{P} = 0 \quad (10)$$

where the dot notation denotes partial differentiation with respect to a parameter while holding both the independent and dependent variables fixed. If  $y$  is considered as a function of  $t$  and  $\lambda$  is equation (3),

$$\frac{d^2}{dt^2} \left( \frac{\partial y}{\partial \lambda} \right) + 2C \frac{dy}{dt} \frac{d}{dt} \left( \frac{\partial y}{\partial \lambda} \right) + \lambda \cos y \frac{\partial y}{\partial \lambda} + \sin y = 0 \quad (11)$$

Some versions of Newton's method make use of equation (10) in solving for particular solutions of equations (2a).

#### Different Versions of Newton's Method

In this paper, the iterative procedure defined by equations (2) is called Newton's method. Bellman (refs. 4 and 5) gave the procedure the name quasilinearization. McGill and Kenneth (ref. 6) use the terminology generalized Newton-Raphson operator for the Frechet derivative of nonlinear differential operators. The three different names are synonymous for the general iterative method.

When the linear variational equations, equations (2a), are solved by a specific algorithm, different writers have coined different names for specialized versions of Newton's method. Perrone and Kao (refs. 7 and 8) transform equations (2) to finite difference equations and solve the resulting linear algebraic equations by relaxation. This algorithm is called nonlinear relaxation by Perrone and Kao.

Other versions of Newton's method are connected with solutions of the linear variational equations depending on a parameter. In mechanics, it is usual to compute a set of solutions for the nonlinear problems for a given set of loads or other parameters. It soon becomes apparent to a user of Newton's method that a solution for one load or parameter is a good zeroth approximation for a solution for a nearby parameter (ref. 9). If  $P(u, \lambda) = 0$ , then  $u$  is a good zeroth approximation for the solution for  $P(y, \lambda + \Delta\lambda) = 0$ . The first iteration of Newton's method,  $m = 1$  in equations (2), is then

$$P'[u](\delta y_1) = -P(u, \lambda + \Delta\lambda) = -\left[\dot{P}(u)\Delta\lambda + \frac{P(u)(\Delta\lambda)^2}{2!} + \dots\right] \quad (12)$$

If the nonlinear operator is linear in the parameter so that quadratic and higher order terms in  $\Delta\lambda$  do not appear, a particular solution of equation (12) follows directly from equation (10). For this case,

$$\delta y_1 = \frac{\partial u}{\partial \lambda} \Delta\lambda \quad (13)$$

$$y_1 = u + \frac{\partial u}{\partial \lambda} \Delta\lambda \quad (14)$$

If Newton's method is terminated after one iteration,  $m = 1$ , equation (14) becomes the zeroth approximation for the next increment on  $\lambda$ . Na and Turski (ref. 10) call this version of Newton's method a solution by parameter differentiation. When the parameter  $\lambda$  is a load parameter and the iteration in equations (2) is continued for the iteration counter  $m > 1$ , Newton's method is also known as the incremental method. Stricklin and Haisler (ref. 11) review various versions of this approach when the linear variational equations, equations (2a), are solved by the finite element method.

The idea of continuing known solutions of nonlinear problems into nearby neighborhoods gives rise to higher order forms of Newton's method. These forms retain higher order derivatives in the Taylor series about a known solution. These higher order methods stem from Taylor series expansions in the independent variable for initial value problems. Davis (ref. 12) designated this method as a solution by analytic continuation because the solutions are capable of extension around singular points in the complex domain. Weinitschke (ref. 13) applied a similar approach to solve axisymmetric shallow shell equations for particular solutions starting at one boundary. He used the Newton-Raphson method to satisfy boundary conditions at a second boundary.

Stricklin, et al., (refs. 14 and 15) and Noor and Peters (ref. 16) combine the idea of analytic continuation with parameter differentiation by computing higher partial derivatives with respect to a parameter. Stricklin and Haisler (ref. 11) refer to the general scheme as a self-correcting

incremental approach to nonlinear problems. Noor does not substitute the high partial derivatives in a Taylor series in  $\Delta\lambda$ , but uses them as basis vectors in a Rayleigh-Ritz solution of the original nonlinear problem.

The modified Newton's method uses the same Frechet derivative for each iteration. Instead of equations (2), the iterative sequence is

$$P'[y_0](\delta y_m) = -P(y_{m-1}) \quad (15a)$$

$$y_m = y_{m-1} + \delta y_m \quad m = 1, 2, 3, \dots \quad (15b)$$

### Convergence

The advantage of having the same linear operator for each iteration step in the modified Newton's method is offset by slower convergence to the solution of the nonlinear problem. Parameter differentiation exhibits slow convergence near limit points where  $\partial u / \partial \lambda$  is infinite.

Kantorovich (ref. 2) proves sufficient conditions for the convergence of Newton's method. The sufficient conditions are restrictive, but, when they apply, the nonlinear problem has a unique solution near the zeroth approximation.

In practical applications of Newton's method, there is not enough information to apply Kantorovich's convergence criterion. However, it is a useful guide because nonlinear problems with unique solutions for a fixed range of parameters will exhibit rapid convergence of Newton's method. When the solutions are not unique, Newton's method can still converge. The lack of uniqueness in the nonlinear solutions is reflected by lack of uniqueness in  $\delta y_m$  at some iteration step  $m$ . A decision on which solution branch to pursue must be made before continuing the iteration.

The theory of the linear differential operators is a guide for making these decisions. Application of the theory of linear ordinary differential equations in finding multiple solutions of nonlinear problems is the topic of the next section.

### VARIATION OF PARAMETERS

One method of analysis is examined here in detail to show how linearization can influence discretization. The method is variation of parameters which is used for finding particular solutions for systems of linear ordinary differential equations. The theory for linear ordinary differential equations is well understood and is a reliable guide for computing their solutions. The variational equations of Newton's method are linear ordinary differential

equations when the nonlinear problem is governed by a system of nonlinear ordinary differential equations.

Assume that the nonlinear problem can be written as

$$P(y) = \frac{dy}{dx} + F(y,x,\lambda) = 0 \quad a \leq x \leq b \quad (16)$$

plus two-point boundary conditions,

$$U(y(a), y(b), \lambda) = 0 \quad (17)$$

The dependent variable  $y$  is a vector function with  $n$  component functions of the independent variable  $x$ . There are  $n$  boundary conditions which may be nonlinear.

The sequence for the  $m$ th iteration step, equations (2), is

$$\frac{d\delta y_m}{dx} + F'[y_{m-1}, x, \lambda] \delta y_m = -P(y_{m-1}, x, \lambda) \quad (18a)$$

$$U'_{m-1} \begin{pmatrix} \delta y_m(a) \\ \delta y_m(b) \end{pmatrix} = -U_{m-1} \quad (18b)$$

$$y_m = y_{m-1} + \delta y_m \quad m = 1, 2, 3, \dots \quad (18c)$$

The Frechet derivative  $F'[y_{m-1}, x, \lambda]$  for this case is the Jacobian of the function  $F(y_{m-1}, x, \lambda)$ . The shorthand notation

$$J_{m-1} = F'[y_{m-1}, x, \lambda] \quad (19)$$

will be used in subsequent equations.

The solution of the linear variational equations, equation (18a), can be written in matrix notation as (see ref. 17, for example)

$$\delta y_m = \Phi_{m \sim m} C + \delta y_{mp} \quad (20)$$



The matrix  $\Phi_m$  contains  $n$  columns, each column contains a linearly independent solution  $\phi(x)$  of the homogeneous differential equations.

$$\frac{d\phi}{dx} + J_{m-1} \phi = 0 \quad (21)$$

The vector  $C_m$  is constant. The vector function  $\delta y_{mp}$  is the particular solution of the differential equation system. The method of variation of parameters is a method of deriving the particular solution using the solutions of the homogeneous equations  $\Phi_m$ . The method introduces the change in variables

$$\delta y_m = \Phi_m z_m \quad (22)$$

where  $z_m$  is a vector function. In the new variables  $z_m$ , equation (21a) is

$$\frac{d\Phi_m}{dx} z_m + \Phi_m \frac{dz_m}{dx} + J_{m-1} \Phi_m z_m = -P(y_{m-1}, x, \lambda) \quad (23)$$

The terms multiplying  $z_m$  vanish identically from equation (23) since each column  $\Phi_m$  satisfies the homogeneous equations, equation (21). The equations

$$\Phi_m \frac{dz_m}{dx} = -P(y_{m-1}, x, \lambda) \quad (24)$$

are solved by inverting the matrix  $\Phi_m$  and integrating each equation.

$$z_m = C_m - \int_a^x \Phi_m^{-1}(\zeta) P(y_{m-1}, \zeta, \lambda) d\zeta \quad (25)$$

Substituting equation (25) back into equation (22) completes the solution for  $\delta y_m$ . Comparing like terms with equation (20) shows that the particular solution is

$$\delta y_{mp} = -\Phi_m(x) \int_a^x \Phi_m^{-1}(\zeta) P(y_{m-1}, \zeta, \lambda) d\zeta \quad (26)$$

Whenever the integrals in equation (26) exist, the particular solution always exists and depends on both the residual error and the solutions of the homogeneous equations, equation (21).

### Boundary Conditions and Compatibility

Determining the values of the constants of integration  $\underline{C}_m$  completes the mth iteration step. The constants depend on the linearized boundary conditions, equation (18b). Substitution of equation (25) into equation (18b) yields a set of linear algebraic equations

$$\underline{B}_m \underline{C}_m = \underline{D}_m \quad (27)$$

$$\underline{B}_m = \underline{U}'_m \begin{bmatrix} \Phi_m(a) \\ - - - \\ \Phi_m(b) \end{bmatrix} \quad (28a)$$

$$\underline{D}_m = -\underline{U}_{m-1} - \underline{U}'_{m-1} [\delta y_{mp}(a); \delta y_{mp}(b)]^T \quad (28b)$$

Assume that the boundary conditions are posed so that  $\underline{B}_m$  is an  $n \times n$  square matrix. Then three possible conditions exist for the solution of equations (27). Let the rank of matrix  $\underline{B}_m$  be  $(n - k)$  where the number  $k$  is the index of compatibility (Ince, ref. 18). Let the rank of the matrix obtained by augmenting  $\underline{B}_m$  with the column vector  $\underline{D}_m$  be  $(n - p)$ . The three conditions are the following:

1.  $k = 0$  There is a unique solution of equations (27) for the constants of integration  $\underline{C}_m$ . The mth iteration step is complete with a unique correction vector  $\delta y_m$  given by equation (20).

2.  $k < p$  The algebraic equations are incompatible (also referred to as inconsistent) and no solution exists for the constants of integration,  $\underline{C}_m$ .

3.  $k = p$  There are  $k$  arbitrary constants in the solutions of equations (27)

$$\underline{B}_m \underline{C}_m^j = 0 \quad j = 1, 2, \dots, k \leq n \quad (29)$$

The solution of the linear variational equations, equation (18), contains  $k$  arbitrary constants  $A_j$ .

$$\delta y_m = \sum_{j=1}^k A_j V_{mj} + \delta y_{m1} \quad (30)$$

The  $V_{mj}$  are linear combinations of the solutions of the homogeneous equations,

$$V_{mj} = \Phi_m C_m^j \quad j = 1, 2, \dots, k \leq n \quad (31)$$

The particular solution  $\delta y_{m1}$  is completely determined and satisfies the boundary conditions,

$$\delta y_{m1} = \Phi_m C_m + \delta y_{mp} \quad (32)$$

The constants of integration  $C_m$  in equations (32) are solutions of a reduced  $(n - k)$  square matrix.

The theory for the compatibility of the boundary conditions is related to Kantorovich's convergence criteria for Newton's method. The first condition  $k = 0$  is part of the sufficient conditions for convergence of Newton's method to a unique solution. Problems with unique solutions converge rapidly using Newton's method and the numerical solution strategy for the zeroth approximation and incrementing parameters is not crucial for convergence.

The second condition  $k < p$  indicates a break in the iteration sequence. This condition is not usually met in practice. The matrix  $B_m$  becomes ill-conditioned near limit points and approaches the condition  $k < p$ , but does not satisfy the condition exactly. If the assumed solution  $y_{m-1}$  is modified, the boundary conditions may be shifted to make  $k = 0$  or  $k = p$ . This modification follows the same lines as the procedure for the third condition,  $k = p$ , which is considered next.

When  $k = p$ , there are  $k$  arbitrary constants of integration  $A_j$  in the correction function  $\delta y_m$  in equation (30). If the  $A_j$  can be assigned values, the iteration can be continued.

## Multiple Solutions

If  $k$  constants of integration  $A_j$  are arbitrary after  $m$  iteration steps, the nonlinear problem can have multiple solutions for a fixed set of input parameters. The procedure for determining the different solutions depends on the details of the problem, but the analysis contains general guidelines for assigning values for the  $A_j$ . The discussion here considers the  $(m+1)$ th iteration for the case  $\delta y_{m1} = 0$  in equation (30). In other words, it is assumed that convergence has been obtained for a solution  $y_{m-1}$  of the nonlinear problem for a certain value of  $\lambda = \bar{\lambda}$  when the  $A_j$  are zero.

The next step is to investigate continuing the iteration with at least one of the  $A_j$  small but finite. The residual error for the  $(m+1)$ th iteration using  $\delta y_m$  from equation (30) is

$$P(y_m, x, \bar{\lambda}) = F''[y_{m-1}, x, \bar{\lambda}] \left( \frac{\delta y_m^2}{2!} \right) + F'''[y_{m-1}, x, \bar{\lambda}] \left( \frac{\delta y_m^3}{3!} \right) + \dots \quad (33)$$

The residual is nonlinear in the constants  $A_j$ . The lowest order terms are quadratic in the constants unless  $F''[y_m, x, \bar{\lambda}]$  containing second derivatives in the Taylor series vanishes. The linear variational equation for the  $(m+1)$  iteration becomes

$$\frac{d\delta y_{m+1}}{dx} + J_m \delta y_{m+1} = -P(y_m, x, \bar{\lambda}) \quad (34)$$

The Jacobian  $J_m$  is shifted from  $J_{m-1}$  and is also a function of the  $A_j$ . The difference in the two Jacobians appears if the transformation from the  $m$ th iteration is applied to the  $(m+1)$ th step

$$\delta y_{m+1} = \Phi_m z_{m+1} \quad (35)$$

Then, equation (34) is transformed to

$$\frac{dz_{m+1}}{dx} + \Phi_m^{-1} [J_m - J_{m-1}] \Phi_m z_{m+1} = -\Phi_m^{-1} P(y_m, x, \bar{\lambda}) \quad (36)$$

The difference in the Jacobians is a matrix

$$\begin{aligned}
 [J_m - J_{m-1}] &= F'[y_{m-1} + \delta y_m, x, \lambda] - F'[y_{m-1}, x, \lambda] \\
 &= F''[y_{m-1}, x, \lambda](\delta y_m) + \dots
 \end{aligned}
 \tag{37}$$

The leading terms in an expansion for each coefficient of the matrix is linear in the  $A_j$  when the residual error expansion starts with quadratic terms. The leading exponent is always one less than the leading exponent in the residual.

In theory, equation (36) can be solved by variation of parameters. A new set of constants of integration  $\underline{C}_{m+1}$  appears in the solution to be determined by a new set of boundary conditions.

$$\underline{B}_{m+1} \underline{C}_{m+1} = \underline{D}_{m+1}
 \tag{38}$$

The formal solutions contain the undefined  $A_j$  as parameters. In numerical solutions, the explicit dependence of the solution on the  $A_j$  is not known. A procedure that can be implemented for numerical solutions is to partition the problem of determining the constants of integration  $\underline{C}_{m+1}$ , equation (38).

The partitioning identifies  $k$  constants of integration as corrections  $\delta A_j$  on the  $A_j$  and partitions equation (38) into a  $k$  by  $k$  problem to fix the  $A_j$  and  $\delta A_j$ . An iterative procedure is to use trial values for the  $A_j$  and solve for the  $\delta A_j$ . The  $k$  by  $k$  problem is solved when the  $\delta A_j$  vanish for finite real  $A_j$ .

The  $\delta A_j$  appear as the first  $k$  variables of  $\underline{C}_{m+1}$  when the  $V_{mj}$  from equation (30) are arranged in the first  $k$  columns of  $\Phi_m$  in equation (35). Once the  $A_j$  and  $\delta A_j$  are determined, the remaining  $(n - k)$  equations in equation (38) are a linear set of algebraic equations in the remaining  $(n - k)$  constants in  $\underline{C}_{m+1}$ .

To avoid converging back to the solution  $y_{m-1}$  with the  $A_j = 0$ , a shift in  $\lambda$  is introduced to provide for nonzero, real solutions for the constants  $A_j$ .

The shift in  $\lambda$  is introduced in the right side of equation (34) which is replaced by

$$P(y_m, x, \lambda) = P(y_m, x, \bar{\lambda}) + \dot{P}(y_m, x, \bar{\lambda})(\lambda - \bar{\lambda}) + \dots
 \tag{39}$$

and the right side of equation (36) is

$$-\Phi_m^{-1}P(y_m, x, \lambda) = -\Phi_m^{-1}P(y_m, x, \bar{\lambda}) - \Phi_m^{-1}\dot{P}(y_m, x, \bar{\lambda})(\lambda - \bar{\lambda}) + \dots \quad (40)$$

Introducing  $\lambda$  as a free parameter allows iterating on the reduced  $k$  by  $k$  problem by assigning a value to one  $A_j$  and using  $\lambda$  as part of the minimization on  $\delta y_{m+1}$  by making  $\delta A_j$  zero or small compared to  $A_j$ .

Which  $A_j$  to replace as a variable by  $\lambda$  depends on the modal coupling in the given problem. When  $k = 1$ , there is only one  $A_j = A_1$  so the choice is not arbitrary.

The case  $k = 1$  is a common case for problems with limit points or isolated bifurcation points. Therefore, the general iterative procedure for  $k = 1$  will be examined further.

#### Isolated Bifurcation Point

For an isolated bifurcation point,  $y_{m-1}$  is identified as a solution of the nonlinear problem at  $\lambda = \bar{\lambda}$  and  $k = p = 1$ . In applications of Newton's method, the solution  $y_{m-1}$  can be generated by simply incrementing the parameter  $\lambda$  in numerical solutions to approach the bifurcation point and continue past it. As  $\lambda$  is varied in increments in any numerical solution using Newton's method, the boundary condition matrix  $B$  approaches  $B_m$  in equation (29). The rows of  $B$  can be rearranged by elementary operations so that the coefficients of at least one row, say row  $k = 1$ , are small as  $\lambda$  approaches  $\bar{\lambda}$ . For a bifurcation point, the element  $k$  of the  $D$  vector is identically zero for  $\lambda$  near  $\bar{\lambda}$ .

For a limit point, the  $k$ th component of  $D$  may be small but the small divisors of  $B$  prevent convergence at  $\lambda = \bar{\lambda}$  without analysis similar to the bifurcation analysis described here.

When  $y_{m-1}$  is a solution at the bifurcation point  $\lambda = \bar{\lambda}$ , setting  $A_1 = 0$  so that  $y_m = y_{m-1}$  and varying  $\lambda$  continues the solution so that

$$\delta y_{m+1} \cong \frac{\delta y_{m-1}}{d\lambda} (\lambda - \bar{\lambda}) \quad (41)$$

as noted in the discussion on parameter differentiation and equation (13).

Having one solution near  $\bar{\lambda}$ , the problem is to investigate the second solution of the nonlinear problem whose existence is identified by  $V_1$ , the nontrivial solution of the linear variational equations.

A simple procedure for Newton's method is to assign a value to  $A_1$  so that  $y_m = y_{m-1} + A_1 V_1$  is a known function. Solve the first scalar equation

of the set of equations (36) where the equations are arranged so that the first element of  $z_{m+1}$  multiplies the vector function  $V_1$ . The right side of the single differential equation is the first element of equation (40). The constant of integration  $\delta A_1$  for this equation can be set to zero if  $(\lambda - \bar{\lambda})$  is selected to make the first component of  $D_{m+1}$  in the boundary conditions, equation (38), vanish.

For numerical solutions, the analysis required by the expansion in equation (40) can be circumvented by recognizing that while the solution for  $\delta A_1$  is nonlinear in  $A_1$ , it is approximately linear in  $(\lambda - \bar{\lambda})$ . The constant of integration for  $\delta A_1$  can be minimized by interpolating linearly between solutions for residuals  $P(y_m, x, \bar{\lambda} + \Delta\lambda_{m+1})$  and  $P(y_m, x, \bar{\lambda})$  where  $\Delta\lambda_{m+1}$  is small but arbitrary. This interpolation on  $\lambda$  to determine  $\lambda = \lambda_{m+1}$  for fixed  $A_1$  is shown schematically in figure 1. The figure represents the surface  $\delta A_1 = \delta A_1(A_1, \lambda)$ . It is desired to compute intersections of the surface and the  $A_1 - \lambda$  plane. The surface is tangent to the plane along the  $\lambda$  axis, but solutions with  $A_1 = 0$  are already assumed known by equation (41). Curves on the surface for constant  $\lambda$  are nonlinear in  $A_1$  while curves for constant  $A_1$  are assumed to be nearly linear. Therefore, one can fix  $(A_1)_m \pm 0$  and approximate  $\lambda_{m+1} = \lambda_m + \Delta\lambda$  by interpolating on  $\lambda$  between the calculated points  $\delta A_1[(A_1)_m, \lambda_m]$  and  $\delta A_1[(A_1)_m, \bar{\lambda}]$  to approximate  $\delta A_1[(A_1)_m, \lambda_{m+1}] = 0$ .

Once  $A_1$  is determined and  $\lambda = \lambda_{m+1}$  the remaining  $(n - 1)$  equations of equation (38) can be solved to complete the  $(m+1)$ th iteration. When  $A_1$  is small, the terms in  $[J_m - J_{m-1}]$  can be neglected in these equations or handled by successive approximations.

Since  $[J_m - J_{m-1}]$  is of lower degree than the residual, successive approximations should converge rapidly for the remaining  $(n - 1)$  equations, (ref. 18).

If the linearized boundary conditions are no longer singular because of a finite  $A_1$ , the usual Newton method iteration can be continued with  $\lambda$  prescribed as an independent parameter. If the boundary conditions are nearly singular, another interpolation on  $\lambda$  may be required.

Once the analysis shows how to start the Newton's method iteration with a finite value of  $A_1$ , different implicit or explicit numerical integration methods can be used to find  $\lambda$  as a function of  $A_1$ .

## NUMERICAL SOLUTIONS

In applying the results of the theory, numerical solutions do not need to follow the analysis in every detail. For example, "shooting" methods (ref. 19) are used for computing particular solutions rather than variation of parameters. When the problem is partitioned into a reduced  $k$  by  $k$  problem, the complete transformation indicated by equation (35) need not be carried out. The transformation

$$\delta y_{m+1} = w z_{m+1} \quad (42)$$

is sufficient where  $w$  is not singular and contains the  $k$  eigenfunctions  $V_{mj}$  as its first  $k$  columns.

The interpolation on  $\lambda$  for fixed  $A_1$  can be carried over to nonlinear partial differential equations which are solved by matrix methods. A finite-element code for general shell problems was used to generate the end-shortening  $u$  as a function of center deflection  $w$  for an isotropic square plate in compression. The amplitude  $w = A_1$  was held constant at  $1.7h$  where  $h$  is the thickness while  $u$  was varied in the role of  $\lambda$ . The interpolation on  $\lambda$  is indicated by the dashed lines in figure 2. One iteration cycle of Newton's method ( $m = 1$ ) with input  $w_0 = 1.7h$  and  $u = 1.0 u_{cr}$  (point A in the figure) shifted the output to  $w_1 = w_0 + \delta w_1 = 1.32h$  (point B). Another separate iteration with input at point C shifted the output to  $w_1 = 1.99h$  and  $u = 4.47 u_{cr}$  (point D). Interpolating on  $u$  gives  $\delta w_1 = 0$  at  $u = 2.97 u_{cr}$  (point E). The latter value of  $u$  was sufficiently accurate to obtain convergence of Newton's method at point F on the solid curve. The solid curve was generated by varying  $u$  in increments starting at point F using the standard Newton iteration of the computer program. Varying the end-shortening with  $w = 0$  over all the plate would merely change the in-plane solution which does not couple with the transverse equilibrium equation for an initially flat plate. Starting the iteration on the computer solution with an assigned amplitude of the lowest buckling mode shape is sufficient to achieve convergence on the postbuckled curve.

When matrix methods are used for the numerical solution of static boundary-value problems, a similarity transformation on the tangent stiffness matrix is analogous to the change of variables in variations of parameters. When the equations are partitioned using only  $k$  modes, equations (42), the analog is an equivalence transformation in matrix theory.

The numerical analogies will not be developed in this paper, but the general development should parallel the discussion here. Eigenvectors of the numerical analog to the Prechet derivative replace eigenfunctions. A  $k$  by  $k$  reduced problem has been suggested by Almroth, et al., (ref. 20). Solving the remaining  $(n - k)$  equation by successive approximations as suggested here preserves linear independence.

#### CONCLUDING REMARKS

Linearization before discretization in Newton's method allows classical linear theory to be applied to nonlinear mechanics problems. The linear theory provides useful qualitative information that can affect convergence of the iterative solution.

The example in the paper, variation of parameters from the theory of linear ordinary equations, shows clearly the interdependence of the residual



error and the properties of the linearized operator in Newton's method. Variation of parameters suggests a change of dependent variables for computing particular solutions. The change in variables is also a means of partitioning the problem to speed convergence of Newton's method when the nonlinear problem has multiple solutions for a given set of parameters.

The change of variables can be extended to numerical solutions using matrix methods by an equivalence transformation. The new variables arise naturally in the problem which is an advantage for writing computer codes for matrix solutions. No prior quantitative information on choice of variables is required by the program user.

## REFERENCES

1. Ortega, J. M.; and Rheinboldt, W. D.: On Discretization and Differentiation of Operators with Application to Newton's Method, J. SIAM Numerical Analysis, Vol. 3, No. 1, 1966, pp. 143-156.
2. Kantorovich, L. V.; and Akilov, G. P.: Functional Analysis in Normed Spaces, Macmillan Company, New York, 1964.
3. Thurston, G. A.: Newton's Method Applied to Problems in Nonlinear Mechanics, Journal of Applied Mechanics, Vol. 32, Series E, No. 2, 1965, pp. 383-388.
4. Bellman, R.; Kagiwada, H.; and Kalaba, R.: Orbit Determination as a Multipoint Boundary Value Problem and Quasilinearization, Proceedings of the National Academy of Sciences, Vol. 48, 1962, p. 1327.
5. Bellman, R.; and Kalaba, R.: Quasilinearization and Nonlinear Boundary Value Problems, Elsevier, New York, 1965.
6. McGill, R.; and Kenneth, P.: Solution of Variational Problems by Means of a Generalized Newton-Raphson Operator, AIAA Journal, Vol. 2, No. 10, 1964, pp. 1761-1766.
7. Perrone, N.; and Kao, R.: A General Nonlinear Relaxation Iteration Technique for Solving Nonlinear Problems in Mechanics, Journal of Applied Mechanics, Vol. 38, Series E, No. 2, 1971, pp. 371-376.
8. Kao, R.; and Perrone, N.: Asymmetric Buckling of Spherical Caps with Asymmetrical Imperfections, Journal of Applied Mechanics, Vol. 38, Series E, No. 1, 1971, pp. 172-178.
9. Thurston, G. A.: A Numerical Solution of the Nonlinear Equations for Axisymmetric Bending of Shallow Spherical Shells, Journal of Applied Mechanics, Vol. 28, Series E, No. 4, 1961, pp. 557-562.
10. Na, T. Y.; and Turski, C. E.: Solution of the Nonlinear Differential Equations for Finite Bending of a Thin-Walled Tube by Parameter Differentiation, Aeronautical Quarterly, Feb. 1974, pp. 14-18.
11. Stricklin, J. A.; and Haisler, W. E.: Evaluation of Solution Procedures for Material and/or Geometrically Nonlinear Structural Analysis, AIAA Journal, Vol. 11, No. 3, 1973, pp. 292-299.
12. Davis, H. T.: Introduction to Nonlinear Differential and Integral Equations, Dover Publications, New York, 1962.
13. Weinitschke, H. J.: On the Nonlinear Theory of Shallow Spherical Shells, SIAM Journal, Vol. 6, No. 3, 1958, pp. 209-231.

14. Massett, D. A.; and Stricklin, J. A.: Self-Correcting Incremental Approach in Nonlinear Structural Mechanics, AIAA Journal, Vol. 9, No. 12, 1971, pp. 2464-2466.
15. Stricklin, J. A.; Haisler, W. D.; and Von Rieseemann, W. A.: Geometrically Nonlinear Structural Analysis by the Direct Stiffness Method, J. Structural Division, ASCE, Vol. 97, No. ST9, 1971, pp. 2299-2314.
16. Noor, A.; and Peters, J.: Reduced Basis Technique for Nonlinear Analysis of Structures, AIAA Journal, Vol. 18, No. 4, April 1980, pp. 455-462.
17. Coddington, F. A.; and Levinson, N.: Theory of Ordinary Differential Equations, McGraw-Hill, New York, 1955.
18. Ince, E. L.: Ordinary Differential Equations (1926), reprinted by Dover Publications, Inc., New York (1956), Chap. IX.
19. Roberts, S. M.; and Shipman, J. S.: Two-Point Boundary Value Problems: Shooting Methods, Elsevier, NY, 1972.
20. Almroth, B. O.; Stern, P.; and Brogan, F. A.: Automatic Choice of Global Shape Functions in Structural Analysis, AIAA Journal, Vol. 16, May 1978, pp. 525-528.

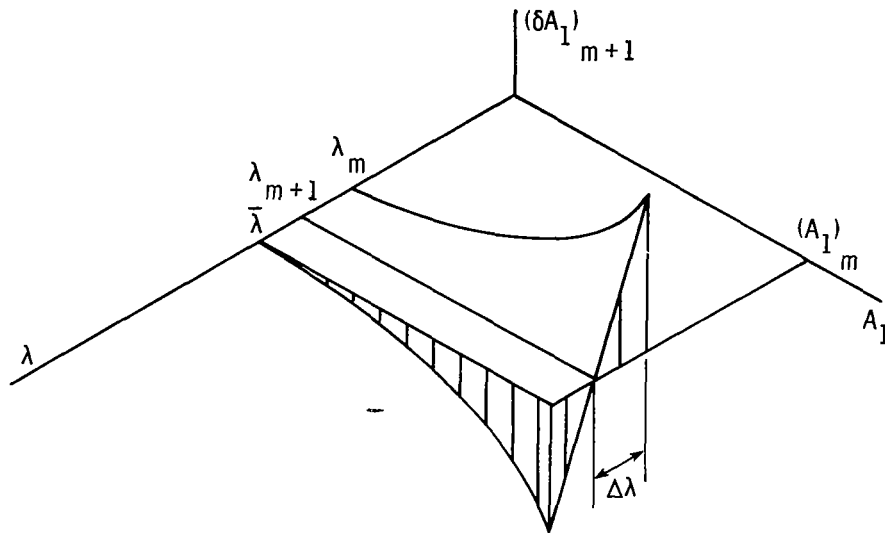

Figure 1.- Schematic diagram of calculation of parameter increment  $\Delta\lambda_{m+2}$ .

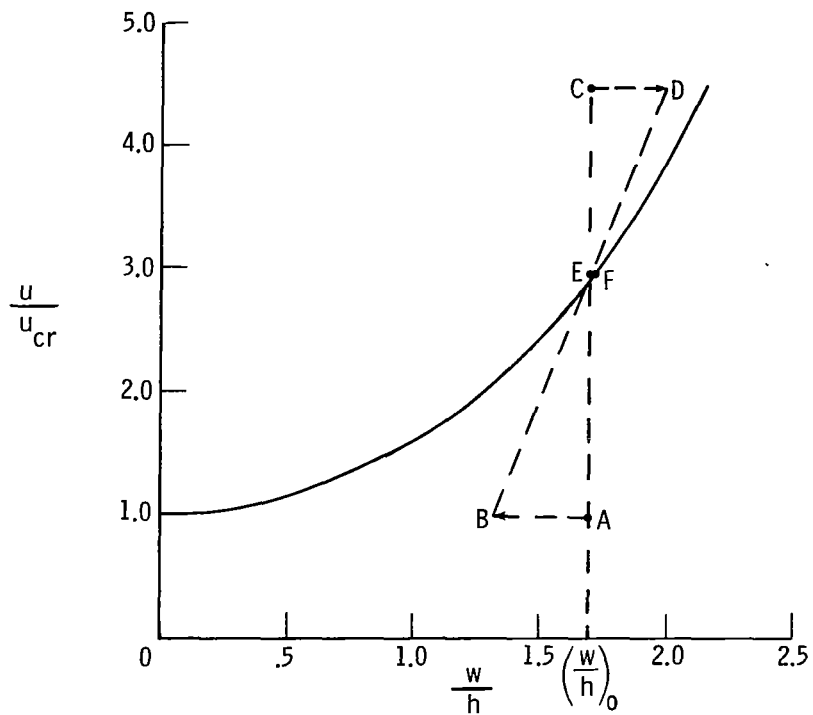

Figure 2.- Variation of end shortening with transverse deflection of plate in compression.