

FINITE CIRCULAR PLATE ON ELASTIC FOUNDATION CENTRALLY LOADED
BY RIGID SPHERICAL INDENTER

S. K. Wadhwa and P. P. Yang

IBM General Systems Division
Rochester, Minnesota

SUMMARY

This paper discusses the analytical solution of a finite circular plate on an elastic foundation centrally loaded by the rigid indenter; and the procedure to use NASTRAN as a subroutine to iteratively converge to this solution numerically.

INTRODUCTION

In contact recording applications, where a thin flexible spinning disk backed by an elastic pad is penetrated by a read/write head, it is important to understand the head penetration, the contact area, and the pressure distribution. A computer program was written to iteratively converge to the solution using MSC/NASTRAN version 60* (hitherto called NASTRAN) as a subroutine. Results were erratic. It was found that extremely fine grid was needed around the contact area to converge to the right solution.

In order to calculate the approximate contact area, the model was simplified to a finite circular plate on an elastic foundation centrally loaded by the head. The approximation is fairly valid because the flexural rigidity of the plate is extremely low and the reaction forces at the center of the spinning disk is about 2% of the total load. The effect of most of the load, thus, is to cause local deformation of the plate between the head and the pad. An analytical solution for this case was obtained. The iterative procedure to converge to this solution by using NASTRAN as a subroutine to verify the analytical solution was also defined.

* MacNeal-Schwendler Corp version of NAsa STRuctural ANalysis.

ANALYTICAL SOLUTION

Consider in figure 1 the spherical indenter with radius R_s being pressed into the circular plate with center at the origin, the plate resting on an elastic foundation with elastic spring constant k . It is of interest to determine the inside contact radius OA and the pressure distribution on the indenter over that contact. Notice, as shown in figure 1, that the outside contact radius is OB and the plate physically separates from the elastic foundation for radii larger than OB . Behavior of this "free" plate can also be modeled easily by matching boundary conditions at B , but it was not necessary in our problem. Instead we were seeking the solution to the problem "what is the outside radius R_o of the plate such that vertical displacement $W=0$ at R_o ?"

The behavior of the plate on elastic foundation can be described (ref. 1) by equation

$$\left[\frac{\partial^2}{\partial r^2} + \frac{1}{r} \frac{\partial}{\partial r} + \frac{1}{r^2} \frac{\partial^2}{\partial \theta^2} \right] \left[\frac{\partial^2 W}{\partial r^2} + \frac{1}{r} \frac{\partial W}{\partial r} + \frac{1}{r^2} \frac{\partial^2 W}{\partial \theta^2} \right] = \frac{q-kW}{D}$$

For our case, in which the indenter presses on the center of the plate, there is a radial symmetry, and the solution is independent of angle θ , we can rewrite the above equation as:

$$\left[\frac{d^2}{dr^2} + \frac{1}{r} \frac{d}{dr} \right] \left[\frac{d^2 W}{dr^2} + \frac{1}{r} \frac{dW}{dr} \right] = \frac{q-kW}{D} \quad (1)$$

Where W = vertical displacement
 q = distributed lateral load
 D = flexural rigidity of the plate,

$$= \frac{Eh^3}{12(1-\nu^2)}$$

h = thickness of the plate
 E = Young's modulus of the plate
 ν = Poisson's ratio of the plate
 k = spring rate/unit area of the elastic foundation.

In seeking the solution for above, we divide the plate into two sections, as shown in figure 2. The inside (section 2) portion conforms to the sphere up to contact radius R_{CI} . The outside portion of the plate must also satisfy differential equation (1) with appropriate matched boundary conditions.

OUTSIDE PORTION OF THE DISK

Consider now the outside portion of the disk (section 1 in figure 2).

If $q = \text{constant}$, such as gravity load, the particular solution of equation (1) is simply $\frac{q}{k}$. Therefore, we now seek the complementary solution (in absence of q) of

$$\left[\frac{d^2}{dr^2} + \frac{1}{r} \frac{d}{dr} \right] \left[\frac{d^2 W}{dr^2} + \frac{1}{r} \frac{d^2 W}{dr} \right] = \frac{-kW}{D} \quad (2)$$

Let us define $\lambda = \sqrt[4]{\frac{D}{k}}$

$$\xi = \frac{r}{\lambda}$$

$$\eta = \frac{W R_s}{\lambda^2}$$

where R_s is the radius of the indenter.

Equation 2 can then be rewritten as

$$\left[\frac{d^2}{d\xi^2} + \frac{1}{\xi} \frac{d}{d\xi} \right] \left[\frac{d^2 \eta}{d\xi^2} + \frac{1}{\xi} \frac{\partial \eta}{\partial \xi} \right] + \eta = 0$$

This is a linear differential equation of the 4th order. The solution can be represented in terms of Bessel's function. However, it is presented below in terms of series solution for ease of computation.

The general solution is given by

$$\eta = A_1 \delta_1 + A_2 \delta_2 + A_3 \delta_3 + A_4 \delta_4 \quad (3)$$

where $A_1 \dots A_4$ are constant,

where

$$\delta_1 = 1 - \frac{\xi^4}{2 \cdot 4^2} + \frac{\xi^8}{2 \cdot 4 \cdot 6 \cdot 8^2} \dots \dots \dots \quad (4)$$

$$\delta_2 = \xi^2 - \frac{\xi^6}{4 \cdot 6^2} + \frac{\xi^{10}}{4 \cdot 6 \cdot 8 \cdot 10^2} \dots \dots \dots \quad (5)$$

Coefficients in above two series can be generated by recursive relationship

$$b_n = \frac{b_{n-4}}{(n^2)(n-2)^2}$$

$$\delta_3 = \delta_1 \log \xi + \Delta_3$$

$$\delta_4 = \delta_1 \log \xi + \Delta_4$$

where

$$\Delta_3 = \frac{3}{128} \xi^4 - \frac{25}{1769472} \xi^8 \dots \dots \dots \quad (6)$$

$$\Delta_4 = \frac{5}{3456} \xi^6 - \frac{1540}{442368} \xi^{10} \dots \dots \dots \quad (7)$$

and coefficients in 6 and 7 can be recursively generated by

$$b_n = \frac{-1}{n^2(n-2)^2} \left[b_{n-4} + \frac{4 \cdot (n)(n-1)(n-2)(-1)^{n/4}}{2 \cdot 2 \cdot 2 \cdot 2 \dots n^2} \right]$$

Four constant $A_1 \dots A_4$ can be thus evaluated by following boundary conditions.

1 At $r = R_{CI}$, $\frac{dW}{dr} = -\frac{r}{R_s}$... conforms to the sphere

Therefore, at $\xi = \frac{R_{CI}}{\ell}$

$$\begin{aligned} \frac{dn}{d\xi} &= \frac{R_s}{\ell^2} \cdot \frac{dW}{d\xi} \\ &= \frac{R_s}{\ell^2} \cdot \frac{dW}{dr} \cdot \frac{dr}{d\xi} \\ &= -\frac{R_s}{\ell^2} \cdot \ell \cdot \frac{\ell \cdot \xi i}{R_s} \\ &= -\xi i \end{aligned}$$

2 At $r = R_{CI}$

$$\frac{d^2W}{dr^2} = -\frac{1}{R_s} \quad \dots \text{conforms to sphere}$$

$$\frac{d^2\eta}{d\xi^2} = -1$$

$$3 \quad \text{Moment} \Big|_{r=R_0} = 0$$

$$\frac{d^2 W}{dr^2} + \frac{\nu}{r} \frac{dW}{dr} = 0$$

or

$$\frac{1}{R_s} \frac{d^2 \eta}{d\xi^2} + \frac{\nu}{\xi_0} \frac{\ell}{R_s} \cdot \frac{d\eta}{d\xi} = 0$$

$$\frac{d^2 \eta}{d\xi^2} + \frac{\nu}{\xi} \cdot \frac{d\eta}{d\xi} \Big|_{\xi=\xi_0} = 0$$

$$4 \quad \text{Shear force} \Big|_{r=R_0} = 0$$

$$\frac{d^3 W}{dr^3} + \frac{1}{r} \frac{d^2 W}{dr^2} - \frac{1}{r^2} \frac{dW}{dr} \Big|_{r=R_0} = 0$$

can be rewritten as

$$\frac{d^3 \eta}{d\xi^3} + \frac{1}{\xi} \frac{d^2 \eta}{d\xi^2} - \frac{1}{\xi^2} \frac{d\eta}{d\xi} \Big|_{\xi=\xi_0} = 0$$

Thus the solution of the outside portion of the disk can be obtained from equation (3).

SOLUTION OF INSIDE PORTION OF DISK

The solution for the inside portion of the disk (section 2, figure 2) that conforms to the sphere satisfies

$$\frac{d^2W}{dr^2} = -\frac{1}{R_s}$$

and, therefore,

$$W = W_i + \frac{1}{2R_s} (R_{CI}^2 - r^2) \quad (8)$$

where W_i = deflection of the disk at $r = R_{CI}$ obtained from equation (3).

PRESSURE DISTRIBUTION

Total force F is given by

$$F = \int_0^{R_o} (kW) 2\pi r \cdot dr$$

where $W = W_i + \frac{1}{2R_s} (R_{CI}^2 - r^2) \quad 0 < r < R_{CI}$

$$= \frac{\ell}{R_s} \left[A_1 \delta_1 + A_2 \delta_2 + A_3 \delta_3 + A_4 \delta_4 \right] \quad R_{CI} < r < R_o$$

Pressure distribution under the head is given by equation (8) multiplied by k . However, at radius R_{CI} there is additional shear force required to keep the outside portion of the disk in equilibrium, and is given by

$$Q = D \left[\frac{d^3W}{dr^3} + \frac{1}{r} \frac{d^2W}{dr^2} - \frac{1}{r^2} \frac{dW}{dr} \right]_{r=R_{CI}}$$

NORMALIZING

Solution to the equations are functions of R_s , F , ℓ , R_o . However, if the disk is very weak and outside radius R_o is taken to be that value for which $W=0$, then from equations (3 through 8), it can be shown that $F R_s$, R_o/ℓ , $Q R_s \ell$, $q R_s \ell^2$ are all normalized functions of R_{CI}/ℓ .

Figures 3 and 4 show some of the relationships.

NASTRAN MODEL DESCRIPTION

The application of the static analysis of MSC/NASTRAN to the problem in figure 1 is demonstrated in this section.

The elastic foundation in figure 1 is first discretized into the "gap scalar spring" of finite length corresponding to grid points on the plate. The "gap scalar spring" is defined as a linear spring that can be compressed only. An extension of this spring will produce no spring force. This spring force will then be used to generate the FORCE card for the NASTRAN program. Secondly, an isoparametric bending element with transverse shear is used to model the plate between the indenter and the elastic foundation. As shown in figure 5, to save computer time, only a section of this circular plate was modeled in this work. A symmetric condition is used along the edge boundaries. Since the spherical indenter can be treated as a rigid body in this problem, its contour is computed and stored in [C]. This [C] is used as an enforced displacement to the plate model within the contact area.

The radius R_{CI} of the contact area between the indenter and the plate is essentially the solution we need. In the following part, an iterative technique was developed to compute the R_{CI} , contact radius, and the load distribution over the plate.

Final solution to the problem must meet the following conditions:

- 1 There should be no geometric interference between the deformed plate and the contour of the indenter. The interference example is as shown in figure 6, where the plate deformation pattern $[W]_1$ interferes with the indenter contour [C]. The smallest R_{CI} without a geometric interference is the solution to this problem.

- 2 The summation of the distributed load, or the "gap scalar spring" force, over the plate be equal to the total force F.

$$\Sigma [q] [\text{area}] = F \quad (9)$$

In order to satisfy the above two conditions, an iterative type of algorithm was developed to solve the problem by utilizing the CALL NASTRAN technique. In this case, the whole NASTRAN program becomes a subroutine that can be implemented by any user-developed program. The NASTRAN program can thus be invoked by using the CALL statement in the user's program just like using any other conventional subroutines.

To start this iteration process, an initial guess of R_{CI} is required as an input to the program. With this assumed R_{CI} , the static contact area between the indenter and the plate can be defined and set equal to the indenter contour by using the enforced displacement card, SPC. Initial plate deflections are obtained by using NASTRAN. With these deflections and the elastic foundation stiffness k , forces on the grid can be calculated satisfying condition (2) above. This $[q]$, as the FORCE cards, along with the previously defined SPC cards, are then put into the NASTRAN program to compute the plate displacement $[W]$. This plate displacement is not supposed to interfere with the indenter contour $[C]$. If this geometric constraint is not satisfied, a larger R_{CI} will be assumed next and repeat the above steps until a R_{CI} can be found that satisfies this geometric constraint. This final R_{CI} is the solution we are trying to obtain. Thus, the static contact area and the final distributed load can be computed accordingly without any difficulty.

Figure 7 shows the simplified flow diagram of this iteration process. Some additional explanations and programming considerations are made below.

- 1 Since the NASTRAN program is being called and invoked many times, NASTRAN CHECKPOINT and RESTART features have been used.
- 2 The CALL NASTRAN statement actually includes the following functions:
 - a Generate the NASTRAN executive control deck, including CHECKPOINT dictionary for RESTART use, Case Control Decks and the Bulk Data Card.
 - b Invoke the NASTRAN program by using a CALL statement. The NASTRAN program is invoked throughout the entry point of its load module. This entry point name is "NASTRAN" in our case.

- c Recover the displacement vector computed by NASTRAN as the output from this CALL NASTRAN operation. The module OUTPUT4 was used to modify the DMAP sequence to get the desired output from NASTRAN.

RESULTS

The iteration scheme defined in the NASTRAN model gave results quite close to those obtained analytically. The graphs are shown in figures 3 and 4. Given force F and the radius R_s of the indenter, contact radius and the pressure distribution can be obtained from figures 3 and 4 respectively.

REFERENCE

- 1 Timoshenko, S., Woinowsky-Krieger, S., "Theory of Plates and Shells", M'Graw Hill Bork Company, New York.

SPHERICAL INDENTER WITH PLATE ON ELASTIC FOUNDATION

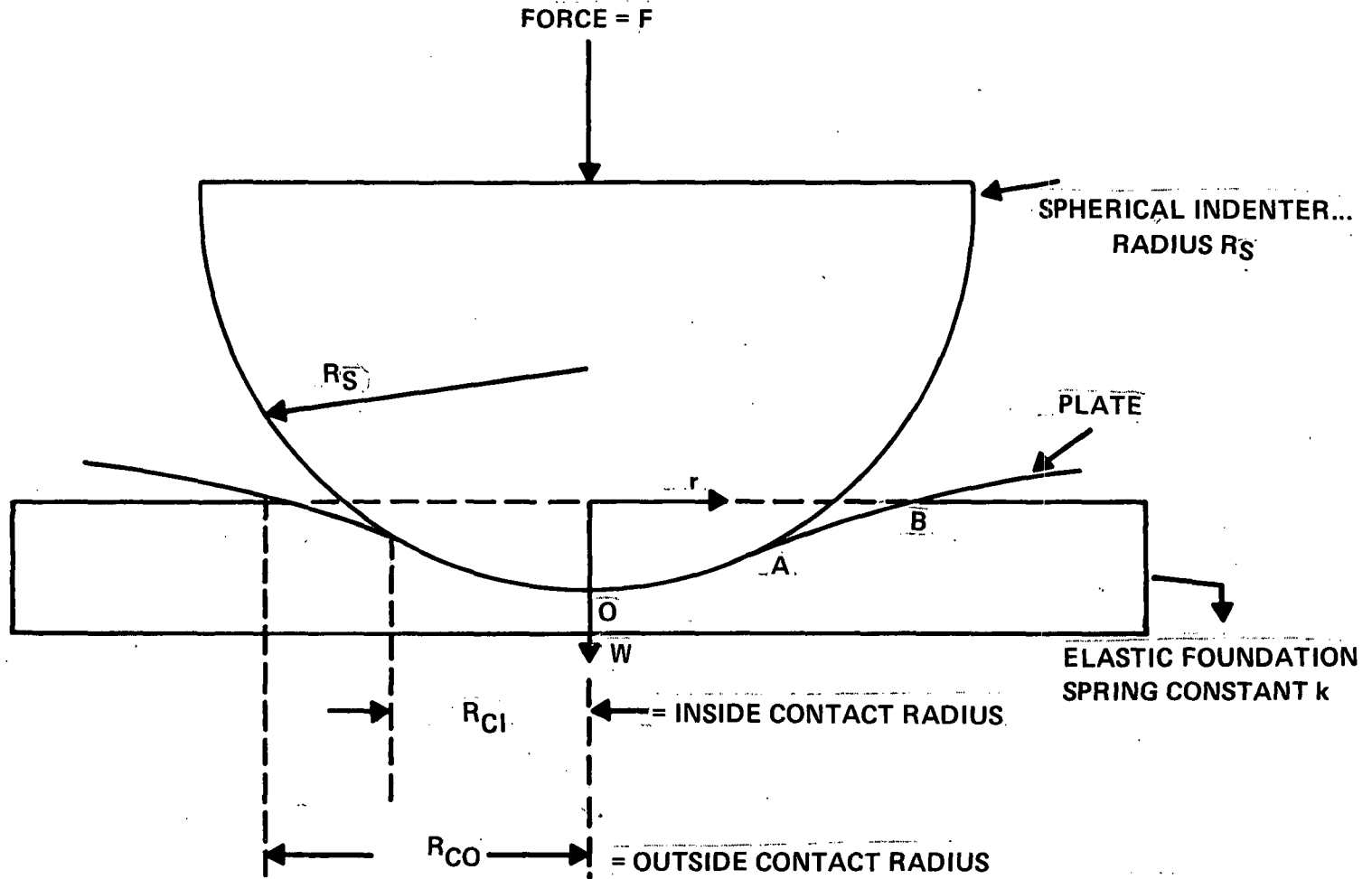

Figure 1. Spherical indenter with plate on elastic foundation

PLATE SHOWN IN TWO SECTIONS. INSIDE PORTION O-A,
CONFORMS TO THE SPHERE WITH RADIUS R_S .

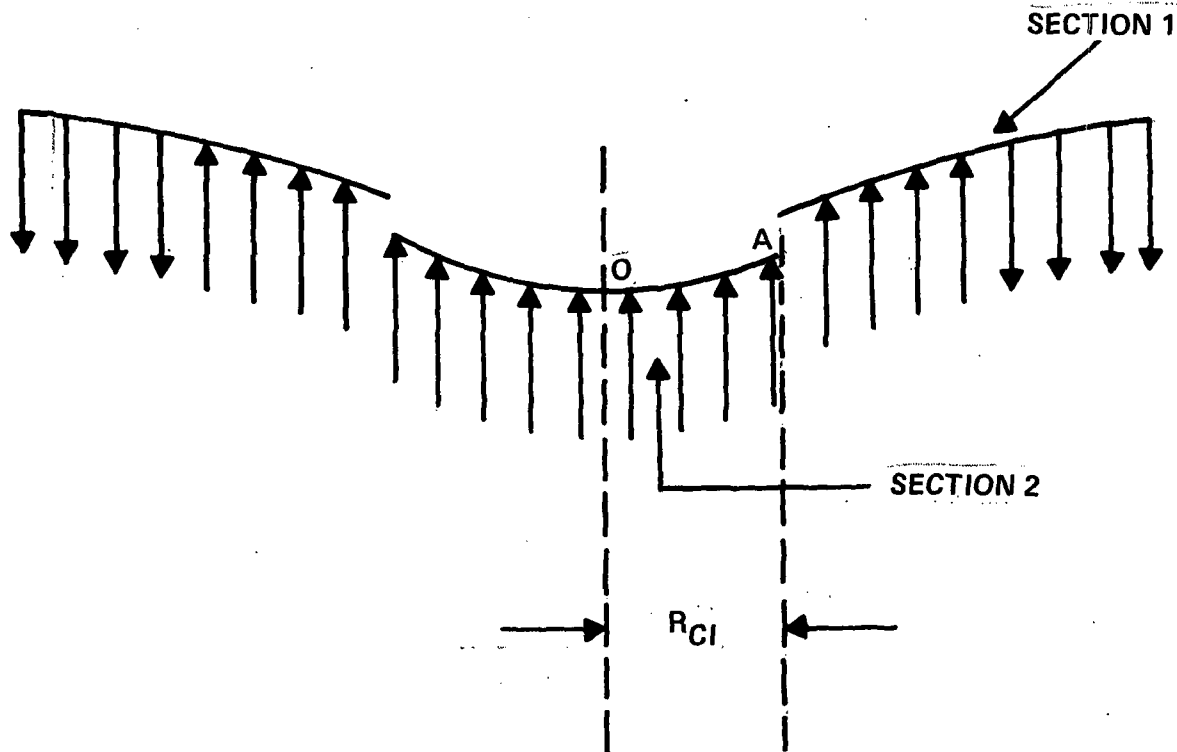

Figure 2. Plate shown in two sections. Inside portion, O-A,
conforms to the sphere with radius R_S .

CONTACT RADIUS

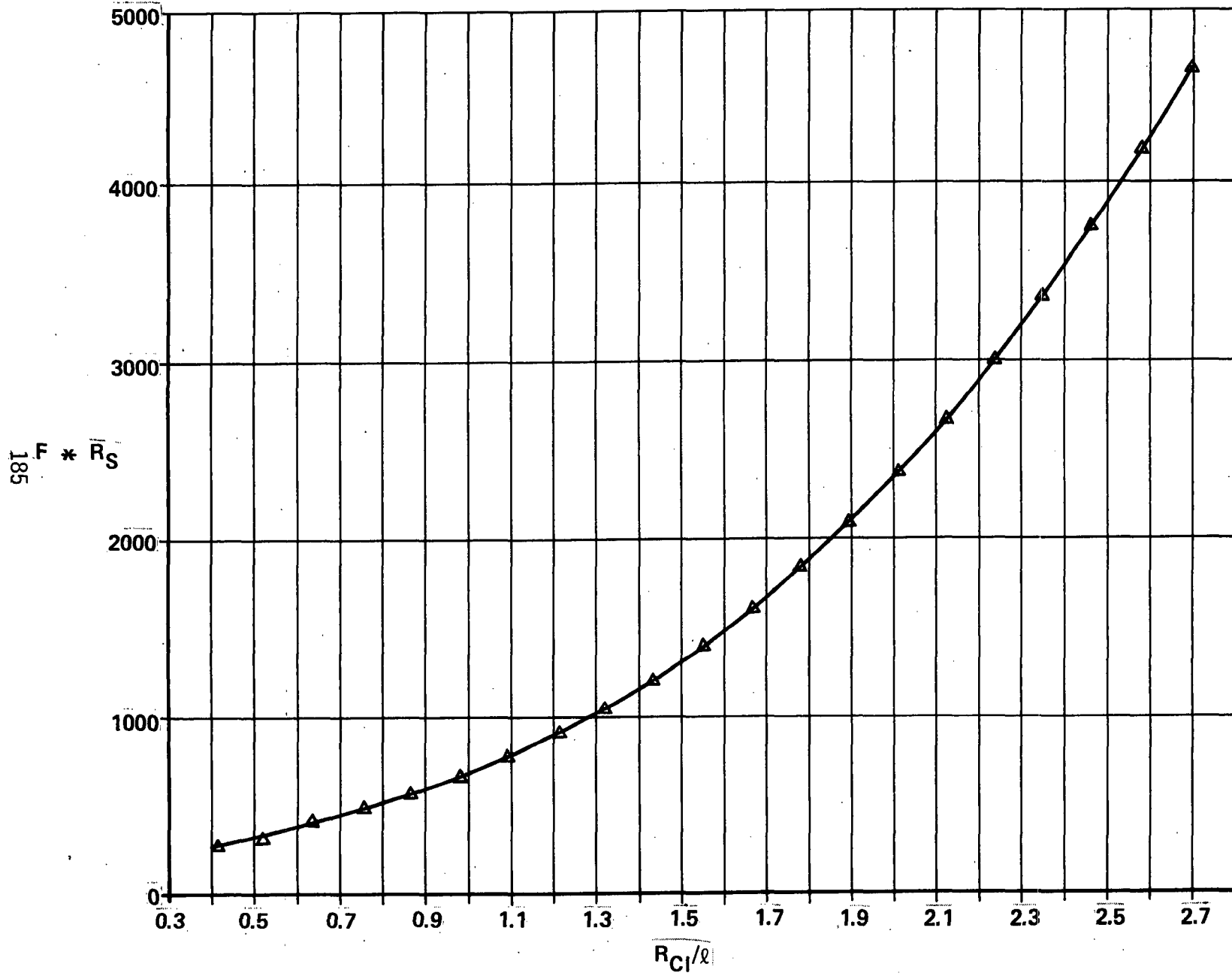

Figure 3. Contact radius

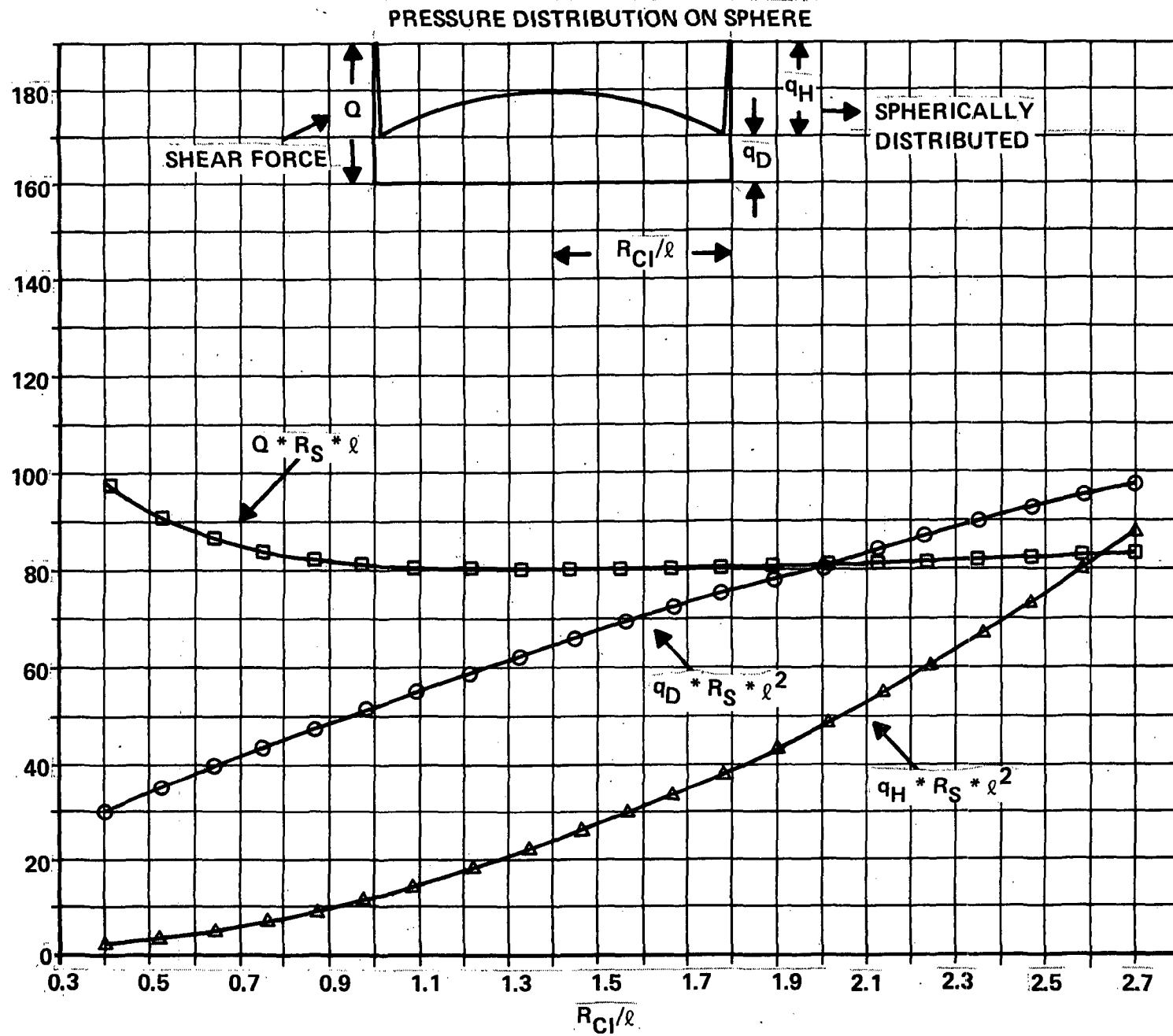

Figure 4. Pressure distribution on sphere

SECTION OF THE CIRCULAR PLATE MODEL

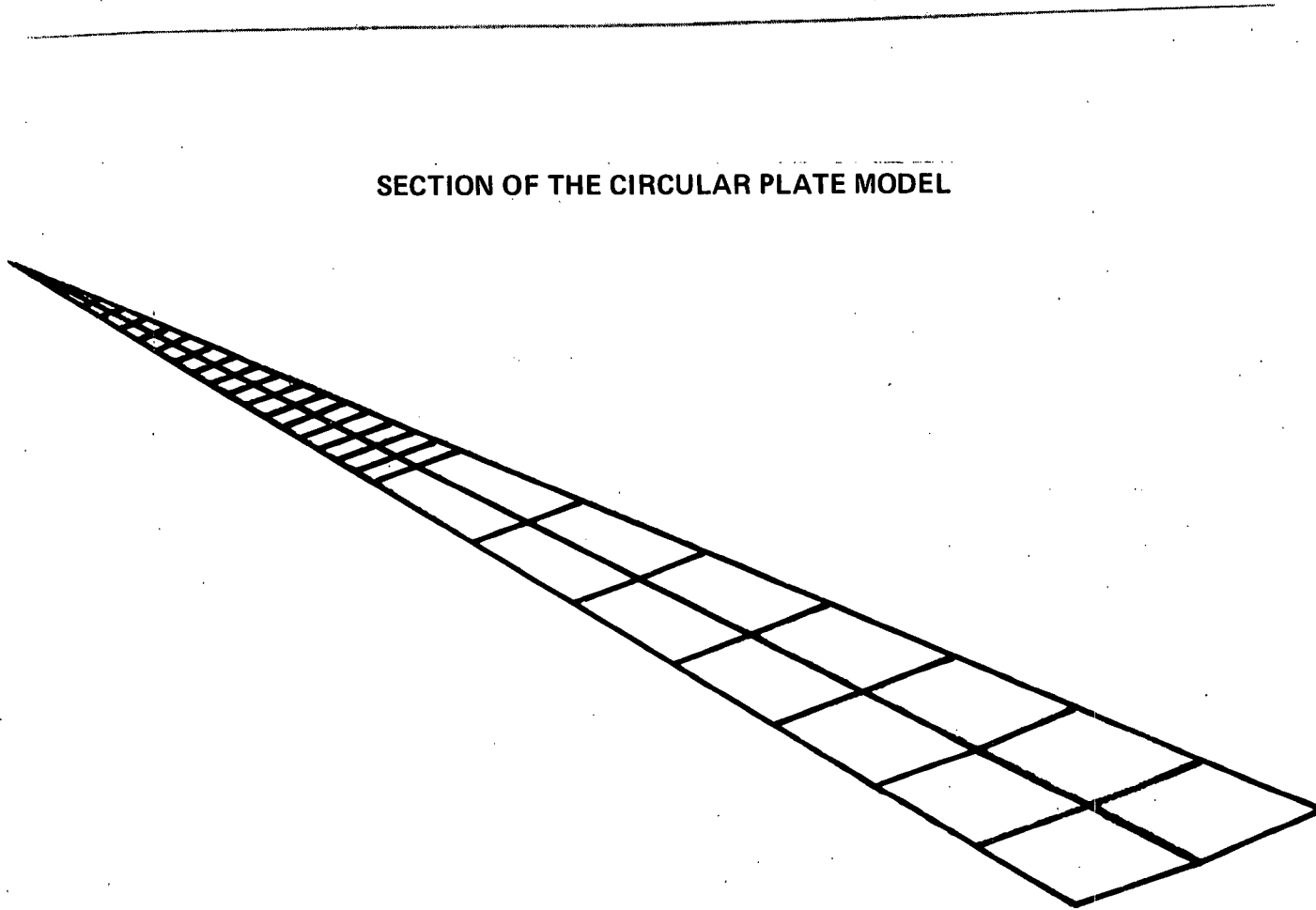
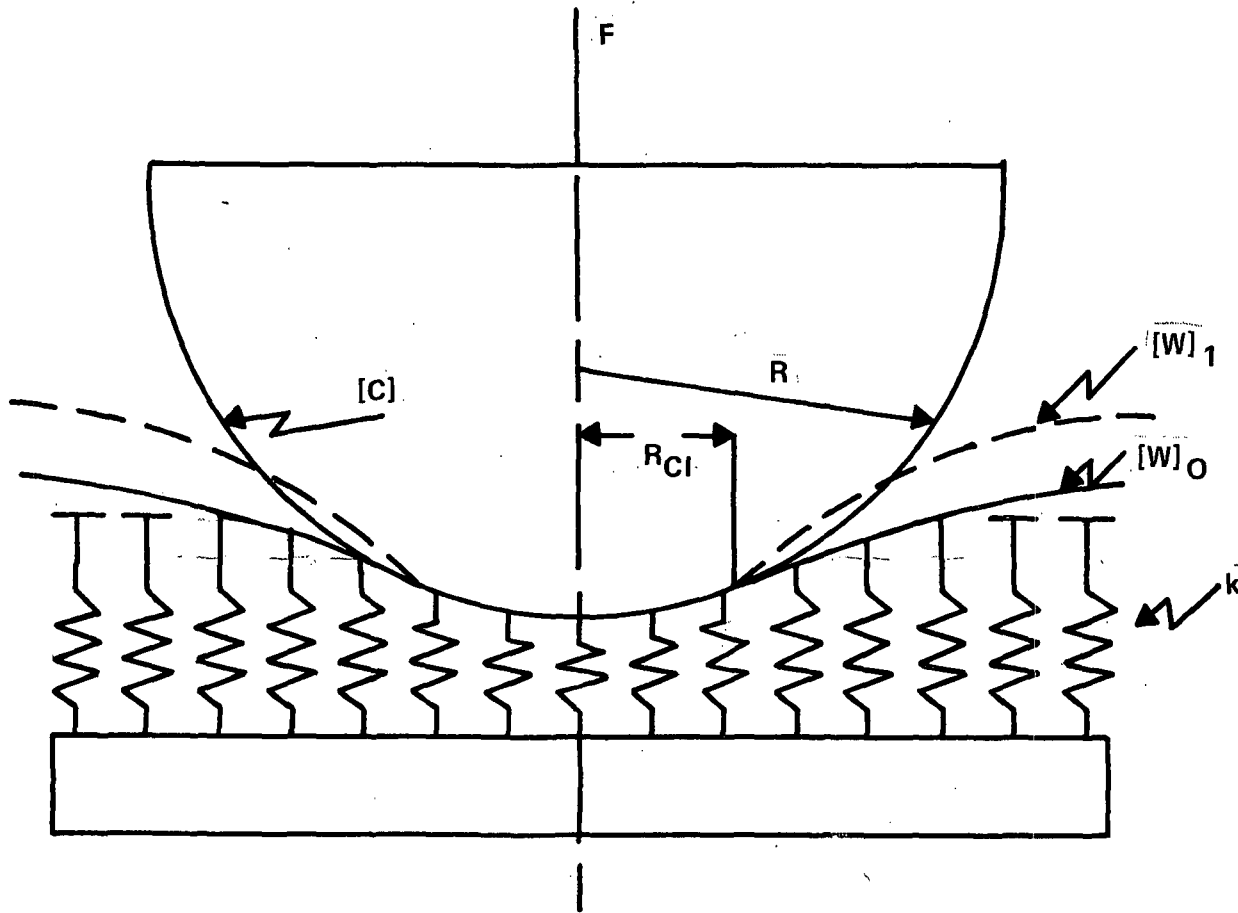

Figure 5. A section of the circular plate model

$[W]_1$ SHOWS GEOMETRIC INTERFERENCE



188

Figure 6. $[W]_1$ shows geometric interference

SIMPLIFIED FLOW DIAGRAM OF THE ITERATION PROCESS

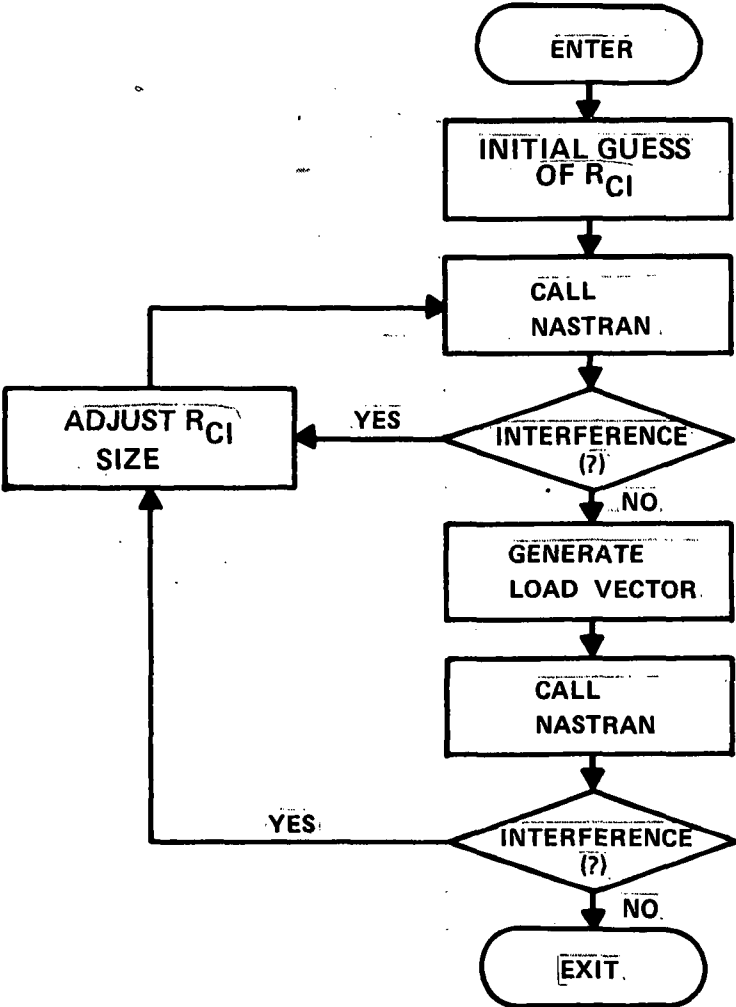

Figure 7. Simplified flow diagram of the iteration process

17