

COMPARISON OF FINITE ELEMENT ANALYSES OF A
PIPING TEE USING NASTRAN AND CORTES/SA

Antonio J. Quezon and Gordon C. Everstine
David W. Taylor Naval Ship Research and Development Center

SUMMARY

A comparison of finite element analyses of a 24" x 24" x 10" piping tee was made using NASTRAN and CORTES/SA, a modified version of SAP3 having a special purpose input processor for generating geometries for a wide variety of tee joints. Four finite element models were subjected to force, moment, and pressure loadings. Flexibility factors and principal stresses were computed for each model and compared with results obtained experimentally by Combustion Engineering, Inc. Of the four models generated, the first was generated from actual measured geometry using GPRIME, a geometric and finite element modeling system developed at DTNSRDC. The other three models were generated from an idealized tee using the data generator contained in CORTES/SA.

The generation of an idealized tee proved to be very easy and inexpensive compared to generation from actual geometry, and, when analyzed by NASTRAN, proved adequate. Results from the NASTRAN analyses were in good agreement with experimental results for all loadings except internal pressure. The CORTES/SA analyses gave good results for the internal pressure loading, but poorer results for out-of-plane bending moments or forces resulting in out-of-plane bending. Two of the basic load cases in CORTES/SA were found to contain errors that could not be easily corrected. A cost comparison of NASTRAN and CORTES/SA showed NASTRAN to be less expensive to run than CORTES/SA for identical meshes. Overall, considering modeling effort, cost, and accuracy, it is concluded that tees can be easily and accurately analyzed by NASTRAN using an idealized mesh generated by CORTES/SA.

BACKGROUND

The designer of a piping system requires a knowledge of the deflections and stresses caused throughout the system by anticipated service loads. Of particular interest are critical components such as elbows and tees.

The purpose of this paper is to summarize the results of a study (ref. 1) made recently to assess the effectiveness of the finite element method (FEM) in predicting flexibility factors and stresses in piping tees subjected to force, moment, and pressure loadings. A similar study (ref. 2), performed for piping elbows, indicated that very good agreement could be expected between FEM

analysis and experiment. Tees, although conceptually no more difficult to analyze than elbows, are considerably more complicated geometrically. A reducing tee, for example, has in the crotch region a fillet with a variable radius of curvature as well as variable thickness. Moreover, the adjacent straight sections may not be cylindrical. Thus, geometrical idealizations of tees, although plausible, may be incorrect.

The finite element analyses described here involve idealized models as well as a model based on actual measured geometry. Two computer programs were used for the analyses: NASTRAN, a widely-used general purpose finite element structural analysis program, and CORTES/SA (ref. 3), a special purpose finite element tee analysis program based on SAP3 and written at the University of California at Berkeley under the sponsorship of the Oak Ridge National Laboratory.* This series of analyses was designed to provide information on the sensitivity of the results to various mesh densities as well as on the adequacy of the assumed idealizations.

In this paper, the program CORTES/SA will be referred to by the abbreviated name "CORTES".

STATEMENT OF THE PROBLEM

Combustion Engineering, Inc., performed an experimental stress analysis (ref. 4) on an ANSI B16.9 carbon steel tee designated T-12. Pipe extensions were welded to the branch and run ends of the tee, and the resulting assembly was placed in a load frame. One of the run ends was built in to represent a fixed end, and the other run end and the branch end were used to apply six orthogonal moments and five orthogonal forces. Internal pressure was also applied. Table 1 and Figure 1 summarize the applied loads. Load case 4 (F3X) was not tested because of strength limitations of the load frame. Stress data for all twelve load cases were gathered from strain gages fixed on specific rows on the tee (Figure 2) and were plotted against normalized surface distance.

The tee analyzed was a reducing tee with a 24-inch-diameter run end and a 10.75-inch-diameter branch. Loads to the run were applied at the free end of the run pipe extension, 173 inches from the branch-run intersection (Figure 1). Loads to the branch were applied at the end of the branch pipe extension, 77 inches from the branch-run intersection. The run pipe extension consisted of 24-inch-diameter schedule 40 (0.687-inch nominal wall thickness) carbon steel piping. The branch pipe extension consisted of 10.75-inch-diameter schedule 40 (0.365-inch nominal wall thickness) carbon steel piping.

The finite element analyses of the tee simulated these loading conditions so that stresses at selected locations could be compared to the experimental

* The CORTES package of computer programs is distributed as program number 759 by the National Energy Software Center (NESC), Argonne National Laboratory, 9700 S. Cass Avenue, Argonne, Illinois 60439.

results. For most load cases, the strain gage rows (Figure 2) selected for comparison were those on which the peak stresses occurred.

ANALYSES PERFORMED

NASTRAN analyses were performed for the first three models generated, and CORTES analyses were performed for the third and fourth models. These five finite element analyses are summarized in Table 2. In the abbreviations N1, N2, N3, C3, and C4 used to identify the analyses, the first character (N or C) indicates the analysis program used (NASTRAN or CORTES), and the second character indicates the mesh used. A typical mesh generated by CORTES is shown in Figure 3. In general, a higher mesh number corresponds to a finer mesh, either overall or in selected key regions of the tee.

The NASTRAN analysis of Mesh 1 was the only analysis performed for a model generated from actual measured geometry. The remaining analyses were performed either by NASTRAN or by CORTES on meshes generated by CORTES assuming an idealized geometry. In all cases only one-fourth of the actual tee was modeled due to symmetry.

For the NASTRAN analyses, the tee, including pipe extensions, was modeled with plate (NASTRAN QUAD2) elements. Flexible beam (BAR) elements were arranged in a spoke formation radiating from an imaginary point in the center of the cross section at the ends of the tee branch and run to facilitate the calculation of the average rotation of these cross sections. Rigid (RIGD1) elements were defined at the ends of the pipe extensions for use in load application. The loads were applied to a point in the center of the rigid cross section at the ends of the pipe extensions.

In the CORTES analyses, the tee and pipe extensions were modeled using an 8-node hexahedral element. This element, designated ZIB8R9, is a modification of the standard Zienkiewicz-Irons isoparametric element and, according to Gantayat and Powell (ref. 3), has bending properties superior to those of the unmodified isoparametric element.

Mesh 1 was modeled from actual geometry as specified in the Combustion Engineering, Inc., report (ref. 4) which tabulated coordinates of points on the outer surface of the tee and thicknesses at these points. From these digitized data, a general B-spline surface was fitted through the supplied points using the geometric and finite element modeling processor GPRIME (refs. 5 and 6). Once this geometric model was defined, GPRIME was used to generate a finite element mesh which included the effects of variable thicknesses.

Mesher 2 through 4 were modeled as idealized tee joints using the automatic mesh generation routine in CORTES. The tee joint is idealized by shallow cones representing the branch and run portions of the tee, connected to each other through an analytically defined transition fillet (ref. 3).

STRESS RESULTS

The results of primary interest are normalized principal stress values for elements in particular locations on the tee. The peak normalized principal stress was plotted against surface distance ratio for each load case and compared to the experimental results obtained by Combustion Engineering, Inc. (ref. 4).

The tee analyzed by Combustion Engineering, Inc., was heavily instrumented, both internally and externally, with strain gages in two of the four quadrants. The gages in each quadrant were arranged in six rows as shown in Figure 2. Since the peak stresses for most load cases occurred on row 1 or row 6, analytical and experimental results were compared for these rows only.

For each load case, the analytical results for principal stresses were normalized by a stress calculated from beam theory, as indicated in Table 1. The normalized principal stresses were then plotted against the surface distance ratios of the elements lying on row 1 and row 6.

Stress plots for several typical load cases are shown in Figures 4 through 8. (Ref. 1 contains plots for all load cases.) All finite element curves are smoothed slightly by fitting B-spline curves (refs. 7 and 8) through the computed values, which are located at element centroids for the NASTRAN results and at grid points for the CORTES results.

FLEXIBILITY FACTORS

Two ambiguities were encountered in comparing computed flexibility factors with experimental results obtained by Combustion Engineering, Inc. These ambiguities involved the definition of flexibility factors and the way in which the rotation of branch or run end cross sections was measured. Combustion Engineering, Inc., defined the flexibility factors as

$$k = \frac{\theta_{\text{meas}} - \theta_{\text{corr}}}{\theta_{\text{nom}}} \quad (1)$$

where

- θ_{meas} = measured rotation at an intermediate location on the pipe extension
- θ_{corr} = rotation correction computed by simple beam theory for the length of pipe between the tee weld line and the location at which the rotation is actually measured
- θ_{nom} = nominal rotation computed by simple beam theory for the distance between the tee weld lines where

$$\theta_{\text{nom}} = \frac{ML}{EI} \quad (\text{for bending moments}) \quad (2)$$

$$\theta_{\text{nom}} = \frac{TL}{JG} \quad (\text{for torsional moments}) \quad (3)$$

$$\theta_{\text{nom}} = \frac{PL^2}{2EI} \quad (\text{for point loads}) \quad (4)$$

Since Combustion Engineering, Inc., could not measure the actual rotations at the branch and run end cross sections, measurements were made at other locations on the pipe extensions and then corrected to the branch and run ends using simple beam theory. On the other hand, the NASTRAN analyses used very flexible beam elements radiating from an imaginary point in the center of the branch and run end cross sections to the points on the circumference of the branch and run ends. This modeling technique allowed an approximate average rotation for the cross sections to be easily obtained for the imaginary center point. However, because plane sections do not, under loading, remain plane, there is no single rotation for a section, so that different methods for computing rotations will yield different results.

For the computation of flexibility factors from the NASTRAN results, the relation

$$k = \frac{\theta_{\text{ab}}}{\theta_{\text{nom}}} \quad (5)$$

was used, where

θ_{ab} = computed relative rotation of end "a" with respect to end "b"

θ_{nom} = nominal rotation computed by beam theory for the rotation of end "a" with respect to end "b"

Flexibility factors were computed for the free branch and run ends with respect to the fixed run end for each load case except for F2X (an axial load on the run) and internal pressure, neither of which causes any significant rotation. For example, the flexibility factor for a rotation about the X-axis of the branch end with respect to the fixed run end is denoted by k_{X31} , where the X in the subscript represents the axis of rotation, the 3 represents the branch end, and the 1 represents the fixed run end. For each load case, flexibility factors for each cross section were computed.

Table 3 compares the flexibility factors computed from the three NASTRAN analyses to the experimental values. The computed flexibility factors compare reasonably well for most load cases, an exception being k_{Z21} for load case 5 (F3Y) of N2. Combustion Engineering, Inc., did not compute flexibility factors for this load case because the stresses and deflections were considered too small to give reliable answers. The displacements computed in the three NASTRAN analyses for load case 5, however, did not appear to be significantly smaller than those of the other load cases, although the run end of the tee did

warp severely in all three analyses. Since the distortions in all three analyses were similar, it appears to have been due to chance that the flexibility factors for N1 and N3 were not also negative for this load case. This implies that any method used to compute a single rotation of the run end is inadequate for severely distorted cross sections. Moreover, the usefulness of a flexibility factor when severe cross-sectional distortion occurs is questionable.

In general, a negative flexibility factor, whether arising from experiment or analysis, is physically impossible, since such a factor implies a rotation in a direction opposite to that of the applied moment. Negative values can arise experimentally whenever rotations measured at one location have to be "corrected" (using beam theory) to yield rotations elsewhere. Negative values can result from a finite element analysis whenever severe cross-sectional distortion occurs, in which case the usefulness of an "average" rotation of the cross section is in doubt.

DISCUSSION OF RESULTS AND CONCLUSIONS

The three NASTRAN analyses of the tee joint were generally in very good agreement with the experimental results and accurately predicted peak stresses for most loadings except load cases 3 (M3Z) and 13 (pressure). Also, as expected, the agreement with the experimental results improved with finer meshes. In general, the two CORTES analyses were slightly less accurate than the NASTRAN analyses except for load case 13 (pressure). We are unable to explain this behavior. While the CORTES results for pressure loading were significantly better than NASTRAN's, the results for load cases 1 (M3X), 8 (M2Y), 10 (F2X), and 12 (F2Z) were worse. Note that most of these load cases involve either out-of-plane bending moments or forces resulting in out-of-plane bending. The CORTES analyses of load cases 6 (F3Z) and 7 (M2X) were also found to contain errors in formulation and coding which could not be easily corrected.

The preparation of the NASTRAN model of mesh 1 (called N1) was the most time-consuming and expensive of all the models, since this mesh was generated from actual geometry. Although the N1 calculations for all load cases except pressure (Figure 8) are in very good agreement with the experimental results, they are not significantly better than those obtained from the other analyses, so the extra effort is not justified.

In a comparison of NASTRAN and CORTES analyses of an identical mesh (Mesh 3), the NASTRAN results (N3) were more consistent and predicted peak stresses more accurately than CORTES for ten of the twelve load cases. Only for M3Z and pressure (Fig. 8) did C3 do better than N3. Although N3 was less expensive than C3 in computer costs, it required slightly more time for input preparation.

Since N3 was in generally better agreement with experimental results than C3, a coarser mesh (Mesh 2) was also analyzed by NASTRAN (N2) and compared

with C3. In all but three of the load cases, M3Z, F3Y, and pressure, N2 was again in better agreement with experimental results than C3. Computer costs from N2 were significantly less than those for C3, as indicated in Table 2.

In an effort to obtain better results from CORTES, a much finer mesh (Mesh 4) was generated and analyzed, so that the results could be compared with N3. This time, overall performance was about equal for the two analyses, although C4 achieved better results than N3 for M3Z, F3Y, M2Z, F2Y, and pressure.

In conclusion, it is apparent that GPRIME, although well-suited in general to the generation of tee meshes based on actual geometry, is more difficult and time-consuming to use than the special purpose idealized tee generator contained in CORTES. Models based on actual geometry also require geometric data that would probably not be generally available to the analyst. For these reasons, CORTES generation of a finite element model based on idealized geometry appears to be acceptable. However, if an analyst is interested in an F3Z or an M2X loading, CORTES should not be used as the analyzer because the program currently contains errors in the coding of these two load cases. Also, as shown by the comparison of N3 with C4, CORTES requires a mesh about 20% finer to obtain results as accurate as NASTRAN.

Overall, considering modeling effort, cost, and accuracy, it is concluded that tees can be easily and accurately analyzed by NASTRAN using an idealized mesh generated by CORTES/SA.

REFERENCES

1. Quezon, A.J.; Everstine, G.C.; and Golden, M.E.: Finite Element Analysis of Piping Tees. Report DTNSRDC/CMLD-80/11, David W. Taylor Naval Ship Research and Development Center, Bethesda, Maryland, June 1980.
2. Marcus, M.S.; and Everstine, G.C.: Finite Element Analysis of Pipe Elbows. Report DTNSRDC/CMLD-79/15, David W. Taylor Naval Ship Research and Development Center, Bethesda, Maryland, Feb. 1980.
3. Gantayat, A.N.; and Powell, G.H.: Stress Analysis of Tee Joints by the Finite Element Method. Report No. US SESM 73-6, Structural Engineering Laboratory, Univ. of California, Berkeley, California, Feb. 1973.
4. Henley, D.R.: Test Report on Experimental Stress Analysis of a 24" Diameter Tee (ORNL T-12). Report CENC 1237, ORNL-Sub-3310-4, Combustion Engineering, Inc., Chattanooga, Tennessee, Apr. 1975.
5. Golden, M.E.: Geometric Structural Modelling: A Promising Basis for Finite Element Analysis. Trends in Computerized Structural Analysis and Synthesis, ed. by A.K. Noor and H.B. McComb, Jr., Pergamon Press, Oxford, England, May 1978, pp. 347-350.
6. Golden, M.E.: The Role of a Geometry Processor in Structural Analysis. New Techniques in Structural Analysis by Computer, ed. by R. Melosh and M. Salama, Preprint 3601, ASCE Convention and Exposition (2-6 Apr 1979), American Society of Civil Engineers, Boston, MA, pp. F1-F17.
7. McKee, J.M.; and Kazden, R.J.: G-Prime B-Spline Manipulation Package-- Basic Mathematical Subroutines. DTNSRDC Report 77-0036, David W. Taylor Naval Ship Research and Development Center, Bethesda, Maryland, Apr. 1977.
8. McKee, J.M.: Updates to the G-Prime B-Spline Manipulation Package-- 26 October 1977. Periodic updates available from the author at the David W. Taylor Naval Ship Research and Development Center, Bethesda, Maryland 20084.

TABLE 1 - SUMMARY OF APPLIED AND NORMALIZED LOADS

Load Case	Applied Load	Nominal Stress	Normalized Load
1. M3X	4.29E5 in-lb	$\frac{M3X}{Z_b}$	29.91
2. M3Y	-6.03E5 in-lb	$\frac{M3Y}{Z_b}$	29.91
3. M3Z	5.98E5 in-lb	$\frac{M3Z}{Z_b}$	29.91
5. F3Y	4.0E4 lb	$\frac{F3Y}{A_b}$	11.91
6. F3Z	5.58E3 lb	$\frac{77F3Z}{Z_b}$	3.884E-1
7. M2X	4.9E6 in-lb	$\frac{M2X}{Z_r}$	285.0
8. M2Y	-7.54E6 in-lb	$\frac{M2Y}{Z_r}$	285.0
9. M2Z	3.40E6 in-lb	$\frac{M2Z}{Z_r}$	285.0
10. F2X	-6.28E5 lb	$\frac{F2X}{A_r}$	50.3
11. F2Y	2.01E4 lb	$\frac{173F2Y}{Z_r}$	1.6474
12. F2Z	2.46E4 lb	$\frac{173F2Z}{Z_r}$	1.6474
13. P	600 psi	$\left(\frac{P D_0}{2t}\right)_r$	5.725E-2

Notes:

1. Load case 4 (F3X) was not tested.
2. The "normalized load" is computed by dividing the experimentally applied load (column 2) by the nominal stress (column 3).
3. Subscripts "r" and "b" above denote "run" and "branch", respectively.

TABLE 2 - COMPARISON OF FINITE ELEMENT ANALYSES:
 NASTRAN vs. CORTES

	N1	N2	N3	C3	C4
NASTRAN or CORTES Analysis	NASTRAN	NASTRAN	NASTRAN	CORTES	CORTES
Idealized or Actual Geometry	Actual	Idealized	Idealized	Idealized	Idealized
Number of Elements	432	420	525	549	626
Number of Nodes	484	473	583	609	689
Number of Degrees of Freedom	2525	2462	3047	3458	3958
Total CP Seconds (CDC 6400)	2213	2200	3135	3310	4748
Cost	\$228	\$226	\$335	\$421	\$605

TABLE 3 - COMPARISON OF FLEXIBILITY FACTORS OF
EXPERIMENTAL RESULTS TO NASTRAN RESULTS

Load Case	k Subscript	Experiment	N1	N2	N3
1. M3X	X21	-0.8	0.82	1.00	0.85
	X31	1.8	2.40	4.00	2.73
2. M3Y	Y21	0.5	0.72	0.76	0.77
	Y31	-0.3	0.32	0.33	0.32
3. M3Z	Z21	0.5	0.73	1.03	0.93
	Z31	0.9	0.90	0.85	0.84
5. F3Y	Z21		1.22	-1.35	1.53
	Z31		1.97	0.51	2.08
6. F3Z	X21		0.85	1.09	0.88
	X31	1.8	2.97	4.94	3.40
7. M2X	X21	-0.4	0.82	1.00	0.85
	X31	-0.5	0.82	1.00	0.85
8. M2Y	Y21	0.7	0.72	0.76	0.77
	Y31	0.6	0.72	0.76	0.77
9. M2Z	Z21	0.9	0.73	1.01	0.93
	Z31	0.8	0.73	1.01	0.93
11. F2Y	Z21	0.8	0.73	1.01	0.93
	Z31	0.8	0.83	1.08	1.01
12. F2Z	Y21	0.7	0.72	0.76	0.77
	Y31	0.7	0.91	0.89	0.94

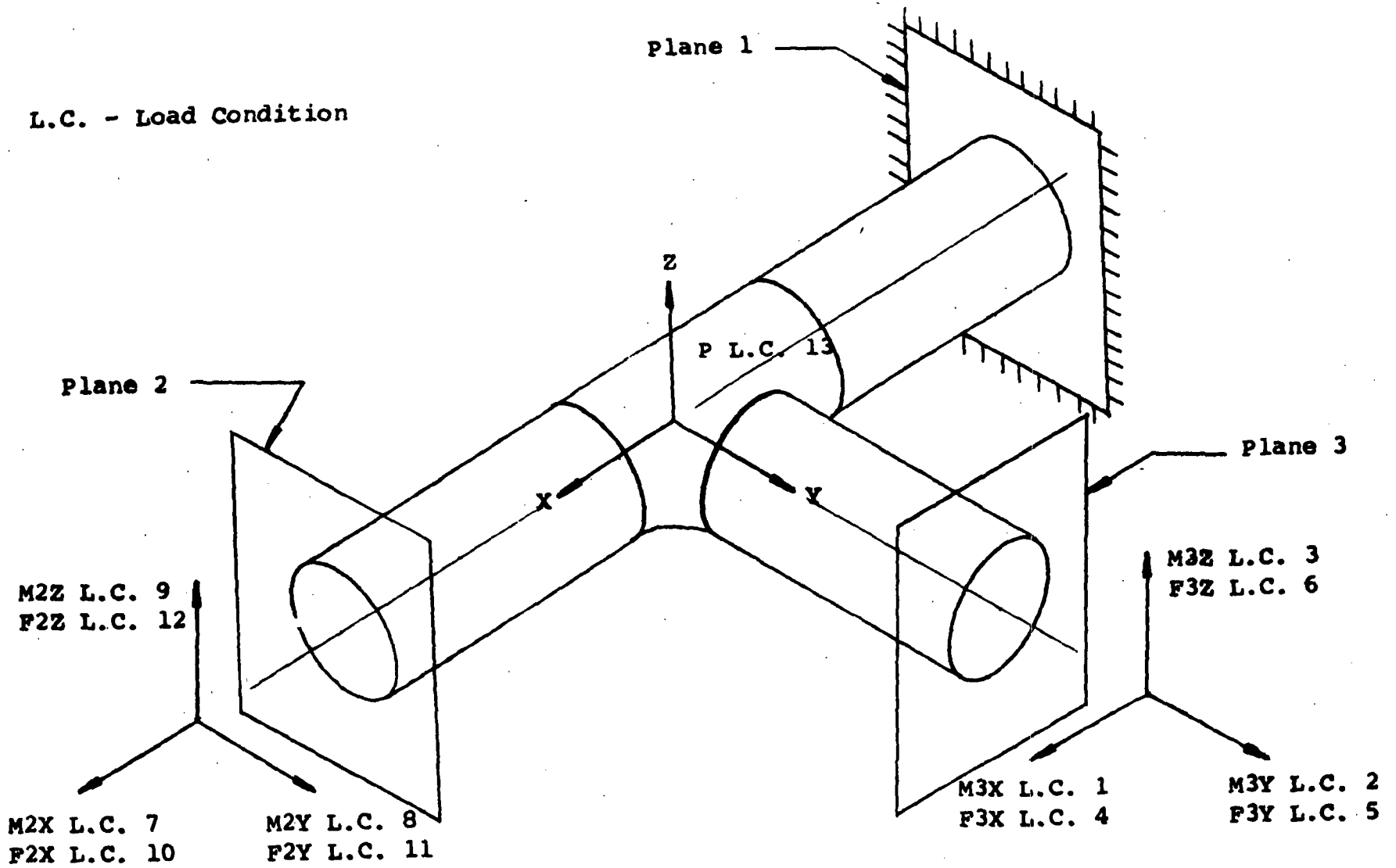

Source: Figure 6, Ref. 4

Figure 1 - Schematic View of Applied Loads for Test Tee

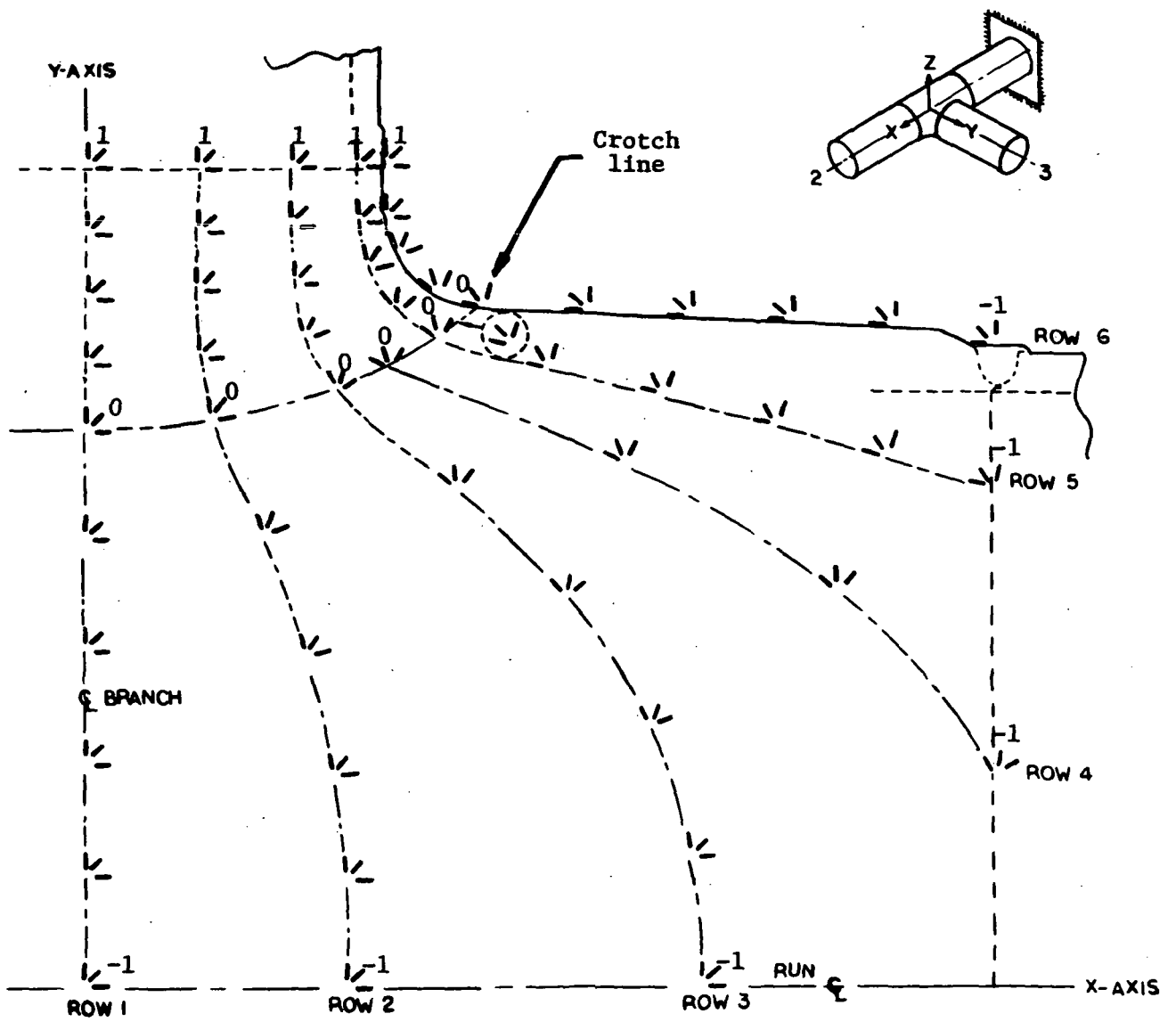

Source: Figure 4, Ref. 4

Figure 2 - Location of Strain Gage Rows on Test Tee

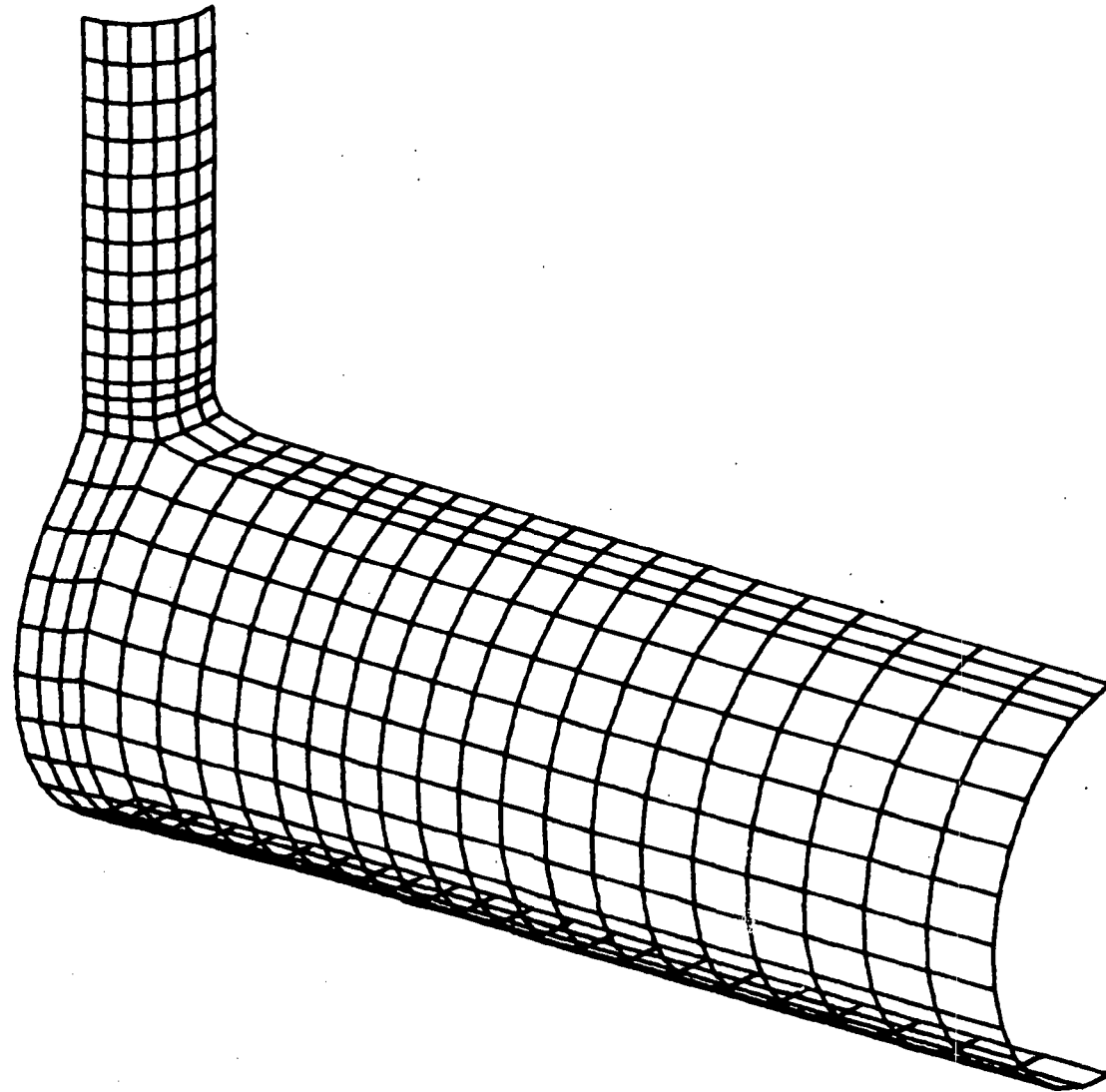

Figure 3 - Finite Element Model of Tee Using Idealized Geometry; Mesh 2

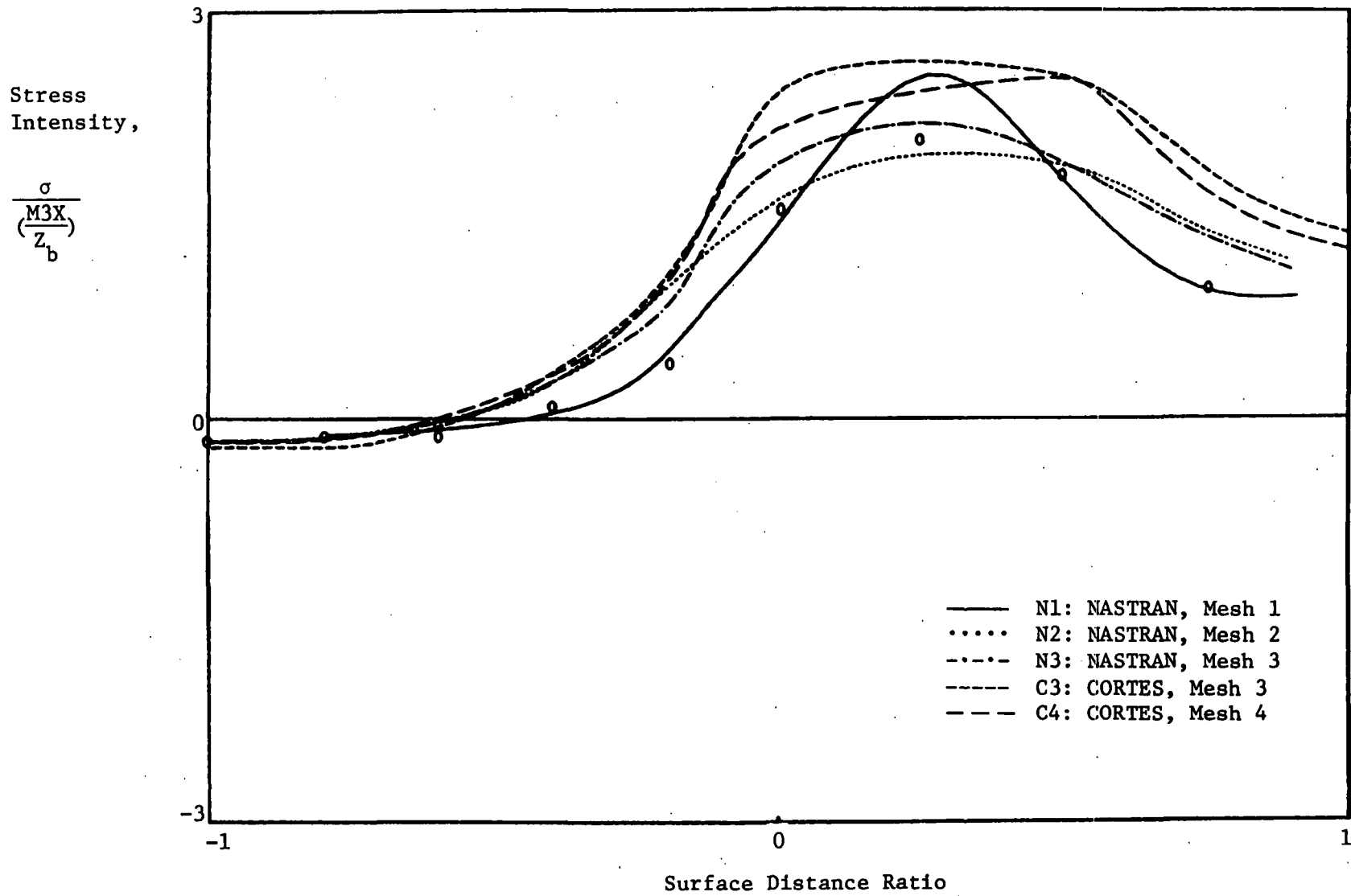

Figure 4 - Normalized Stress Intensity for Load Case 1 (M3X), Row 1, Major Principal Stress on Outer Surface

Stress Intensity,

$$\frac{\sigma}{\left(\frac{M2X}{Z_r}\right)}$$

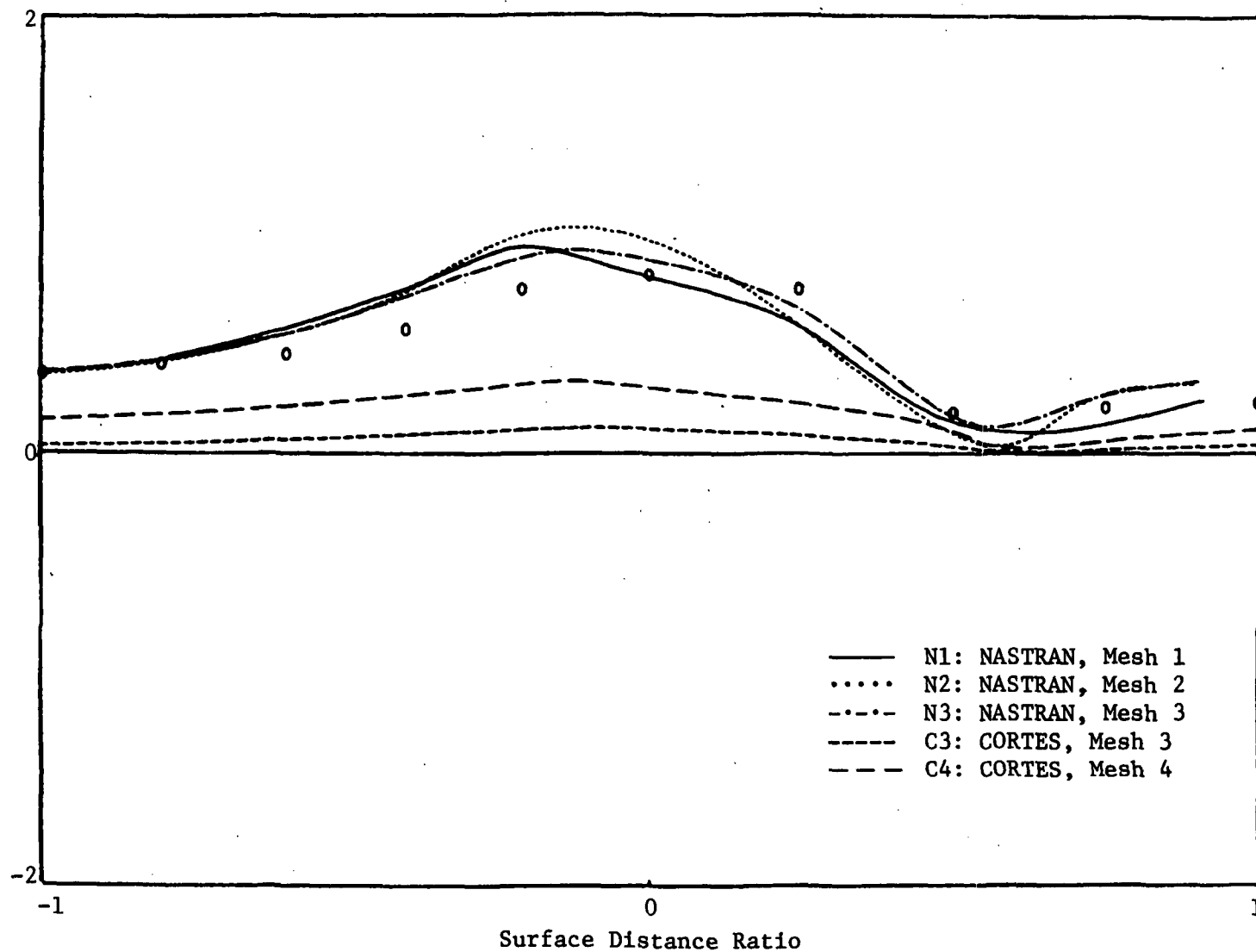

Figure 5 - Normalized Stress Intensity for Load Case 7 (M2X), Row 1, Major Principal Stress on Outer Surface

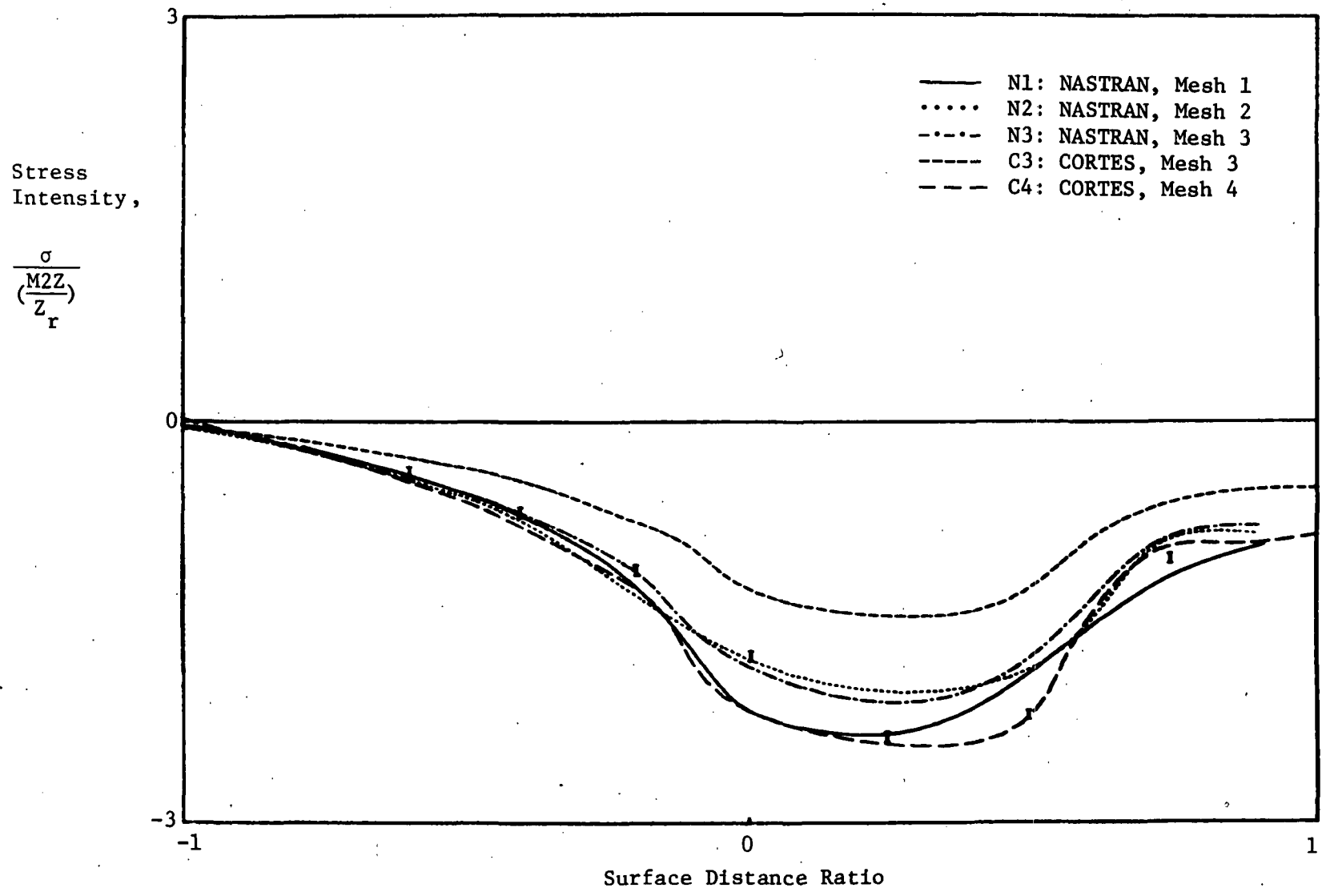

Figure 6 - Normalized Stress Intensity for Load Case 9 (M2Z), Row 1, Minor Principal Stress on Inner Surface

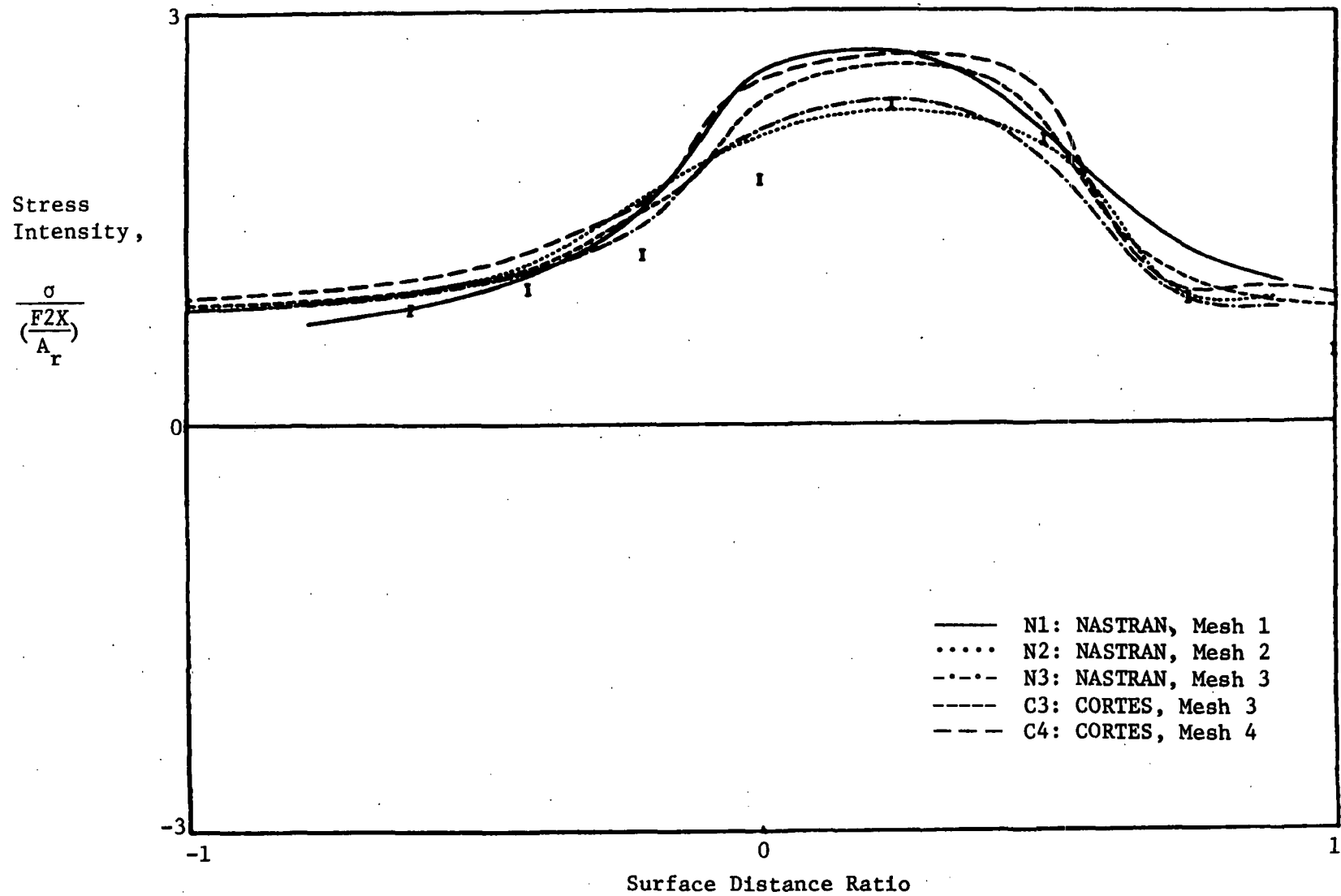

Figure 7 - Normalized Stress Intensity for Load Case 10 (F2X), Row 1,
Major Principal Stress on Inner Surface

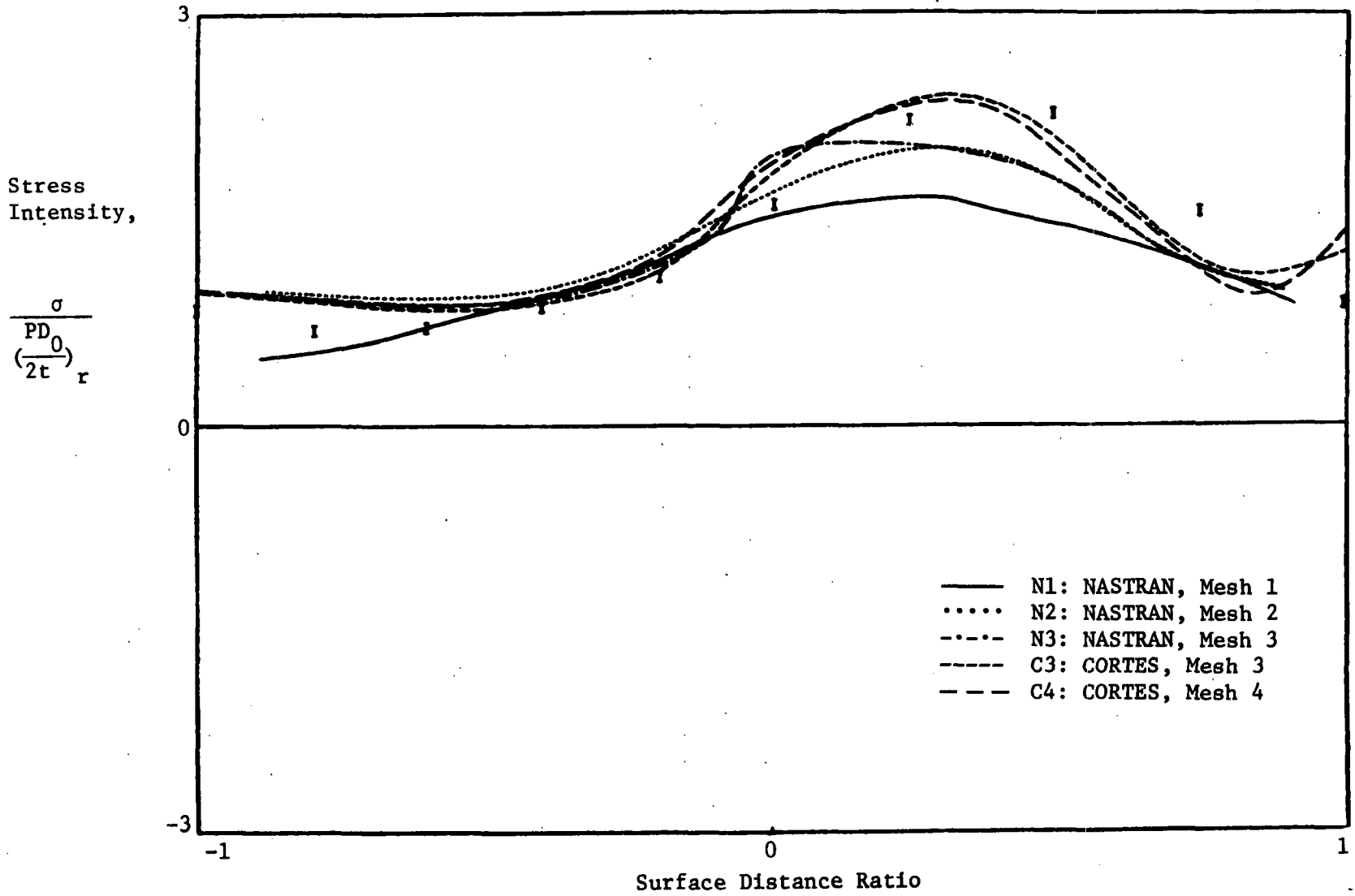

Figure 8 - Normalized Stress Intensity for Load Case 13 (P), Row 6, Major Principal Stress on Inner Surface