



NASA Technical Memorandum 81902

NASA-TM-81902 19810003645

A TECHNOLOGY DEVELOPMENT PROGRAM FOR
LARGE SPACE ANTENNAS

R. A. RUSSELL, T. G. CAMPBELL, AND
R. E. FREELAND

SEPTEMBER 1980

LIBRARY COPY

NOV 7 1980

LANGLEY RESEARCH CENTER
LIBRARY, NASA
HAMPTON, VIRGINIA

NASA

National Aeronautics and
Space Administration

Langley Research Center
Hampton, Virginia 23665

N81-12155#

NASA Technical Memorandum 81903

A TECHNOLOGY DEVELOPMENT PROGRAM FOR
LARGE SPACE ANTENNAS

R. A. RAYBURN, T. G. HARRIS, and
R. H. FREEMAN

September 1980



National Aeronautics and
Space Administration
Langley Research Center
Hampton, Virginia 23061

A TECHNOLOGY DEVELOPMENT PROGRAM FOR LARGE SPACE ANTENNAS

R. A. Russell*, T. G. Campbell*, and
R. E. Freeland**

*National Aeronautics and Space Administration
Langley Research Center, Hampton, VA 23665, USA
**Jet Propulsion Laboratory, California Institute
of Technology, Pasadena, CA 91103, USA

ABSTRACT

Recent studies sponsored by both the National Aeronautics and Space Administration (NASA) and United States (U.S.) industry indicate the need for technology to accommodate potential applications for large space-based antenna systems. These potential space systems require apertures up to 100 meters (m) in diameter and larger for radio frequency (RF) operation up to Ku-band for communications, Earth observations, and radio astronomy applications. NASA's Large Space Systems Technology (LSST) Program was created to develop technology that will lead to the realization of large space systems which are cost-effective and Space Transportation System (STS) compatible. For large space-based antenna systems, the LSST Program has selected deployable antennas for development. The maturity of this class of antenna, demonstrated by the success of smaller size apertures, provides a potential capability for satisfying a significant number of near-term space-based applications. Two specific antenna concepts selected for development are the offset wrap-rib and the maypole (hoop/column) configurations. This paper is focused on a detailed review of the current and planned technology program for the two mesh deployable antenna concepts selected for development. This paper further discusses the NASA mission model that generically categorizes the classes of user requirements, the methods used to determine critical technologies and requirements, and presents performance estimates for the mesh deployable antenna selected for development.

KEYWORDS

Large space antennas; space missions; mesh deployable antennas; focus missions; maypole (hoop/column) antenna; offset wrap-rib antenna; point design.

INTRODUCTION

The expectation of STS along with the desire of NASA to demonstrate and exploit the capability of large space antenna systems for a host of applications offers a unique opportunity for technology development. This development includes: (1) generation of new and innovative concepts and designs, (2) promotion of the development of existing concepts which potentially offer significantly improved performance capabilities with respect to the state of the art, and (3) extension of the performance of proven designs to new and unexpected levels of performance.

The specific technology challenges and drivers have resulted from: (1) the stringent performance requirements projected for large antenna systems operating in a space environment, and (2) the size limitations imposed by the STS payload compartment. To address these technology challenges, the LSST Program was created by NASA to identify technology requirements for the classes of potential mission applications and to manage a technology development program. The basic objective of the LSST Program is to provide systems-level technology for evolving cost-effective, STS compatible antennas and platforms that will be automatically deployed, assembled or fabricated in orbit to perform missions in the 1985 to 2000 time period.

The LSST approach for the development of technology for large aperture antenna systems starts with the synthesis of systems whose performance would satisfy several classes of potential users that have been identified by the NASA Office of Aeronautics and Space Technology (OAST) mission model. The critical technologies associated with the synthesized missions are then used to focus the technology developments within the program. The portion of the LSST Program associated with the technology development of deployable antenna systems is described herein.

MISSION REQUIREMENTS FOR LARGE SPACE ANTENNAS

The identification and definition of critical technologies to be developed by the LSST Program are derived from correlating potential mission requirements with current technological capabilities. This process starts with the development of potential user requirements for classes of missions identified by the NASA mission model. These sets of synthesized needs are referred to as "focus-mission" requirements. These focus-mission requirements are further refined by developing characteristic configurations for each class of missions. These resulting mission scenarios are then used to aid evaluation of candidate antenna concepts.

NASA Mission Model

The determination of requirements for the development of technology for large space antenna systems is dependent on the identification and definition of potential space flight missions by the NASA user offices. User offices proposing future missions currently include: the Office of Space Science (OSS), the Office of Space and Terrestrial Applications (OSTA), and the Office of Aeronautics and Space Technology (OAST). The NASA mission model (Fig. 1) represents a summary of potential missions which will utilize large space systems during the 1985 to 2000 time period. The particular types of missions identified by this mission model that require advanced antenna technology are the precision shaped surface structures. The potential classes of antenna applications are illustrated in Fig. 2. It is anticipated that the number of potential missions will increase, while the requirements become more demanding after the STS becomes operational and a more mature technology for large space antenna systems has been demonstrated. The NASA mission model will be maintained by OAST to account for the addition/deletion of potential missions, as well as the changes and reemphasis in NASA mission requirements.

LSST Focus Missions and Requirements

To guide the development of technology for proposed future missions, the LSST Program Office (LSSTPO) developed the concept of focus missions. A focus mission is based on a set of artificial performance requirements that are representative of a specific class of applications. The focus mission approach is intended to expand the individual mission needs into a matrix of requirements that include many users for one class of applications. The basic advantage of the focus mission approach is that

		1980	1985	1990	1995	2000
HIGH STIFFNESS TRUSS STRUCTURES	MULTIPURPOSE PLATFORMS		SCIENCE APPLICATIONS LEO 30M	COMM OBSER. GEO 50M	COMM. OBSERVATIONS GEO 100M	
	FACILITIES		MATERIALS EXPERIMENTATION CARRIER 10-35M		SPACE OPERATIONS CENTER 100M	
LOW STIFFNESS PLANAR SUB STRUCTURES	POWER MODULES		25 KW (20x20M)		250 KW 100x50M	
	ENERGY SATELLITES				SPS TEST ARTICLE SUBSCALE	
PRECISION/SHAPED SURFACE STRUCTURES	HIGH ENERGY ASTRONOMY			SOLAR X-RAY PINHOLE CAMERA 100M		X-RAY OBSERVATORY 75M DIA.
	SUBMILLIMETER, IR. AND OPTICAL ASTRONOMY			IR SUBMILLIMETER 15M	LINEAR OPTICAL ARRAY 20M	OPTICAL ARRAY 100MD
	RADIO ASTRONOMY			VLBI 5GHz 15M	VLBI 20 GHz 30M	RADIO TELESCOPE 1KMD
	PLASMA PHYSICS		WAVE INJECTION WIRE LEO 200M LONG		WAVE INJECTION WIRE GEO 2KM LONG	
	DEEP SPACE NETWORK				ORBITAL RELAY ANTENNA 30M AT 30GHz OR 300M AT 3GHz	
	COMMUNICATIONS		MOBILE 800MHZ 60MD		SWITCHED TRUNKING 6 & 14 GHz 15MD	ADVANCED APPLICATIONS 1-14GHz 100MD
	REMOTE SENSING		SOIL MOISTURE 10 x 10M PASSIVE 05 x 10M ACTIVE	SOIL MOISTURE ACTIVE 10 GHz 30 MD	SOIL MOISTURE PASSIVE 7GHz 100M	STORMCELL TRACKING ACTIVE 100MD
	OTHER				NIGHT ILLUMINATOR REFLECTOR 100-300M DIA.	GRAVITY WAVE INTERFEROMETER 1-10 KM LONG

Fig. 1. Potential large space systems missions.

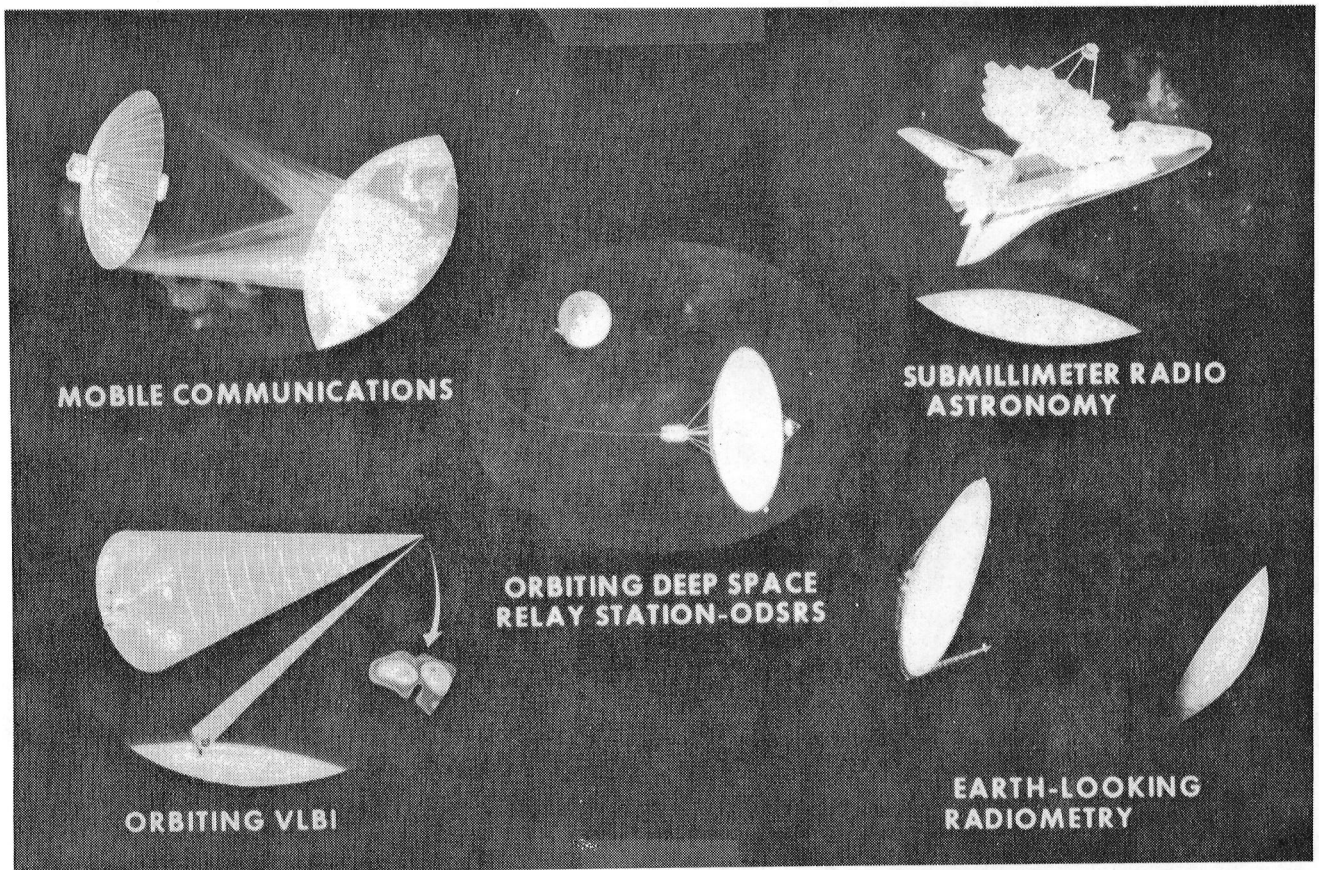

Fig. 2. Potential classes of antenna applications.

the resulting technology will benefit a variety of potential users as contrasted with technology development associated with a specific mission which would benefit only a limited number of users. The focus mission consists of applications in communications, Earth observation, and radio astronomy (refs. 1 and 2). The requirements for these missions are given in Table 1.

TABLE 1 LSST Antenna Focus Mission Requirements

Parameter	Communications	Radiometers	VLBI
Size	30 - 100 m	10 - 100 m	10 - 30 m
Frequency	0.4, 0.8, 2.5 GHz	1 - 11 GHz	1.4 - 30 GHz
f/d (PARENT)	0.5 - 1	1 - 2	0.5 - 1
Pointing Accuracy	0.035 deg	0.05 - 0.025 deg	5 - 10 ^{sec}
Beams	100 - 200	300 - 1000	1
Surface Accuracy	4 - 8 mm	3 - 10 mm	.5 - 3 mm
Feeds	Offset	Offset/On Axis	On Axis
Beam Isolation	30 db	-----	-----
Orbit	GEO	300 - 600 km	400 - 5000 km
Resolution	-----	1 - 5 km	-----
Revisit	-----	3 days - 1 week	-----
Swath Width	-----	±30 deg	-----
Power Requirements	5 kW	TBD	TBD
Lifetime	10 yr	10 yr	10 yr

LSST Mission Scenarios

Since the same set of focus-mission requirements can potentially be accommodated by antenna concepts that are based on different configurations, characteristic configurations for each focus mission need to be identified. Therefore, a scenario for each focus mission was developed by the LSST Program so that baseline antenna configurations could be used to aid identification and selection of candidate concepts for LSST development. A flow chart that outlines the mission scenario approach for supporting the LSST antenna development plan is shown in Fig. 3. A detailed discussion of the mission scenario approach for the LSST antenna focus mission has been presented in ref. 3. The results are summarized in Table 2 for the communications, radiometry, and radio astronomy missions.

Communications. The communication satellites planned for the 1980's will be extensions of current practices and technology. Therefore, the satellite systems needed for the 1990's and beyond must provide an economic alternative to the proliferation of individual spacecraft and orbital/frequency crowding that is inevitable. Recent NASA-sponsored studies (refs. 4 and 5) have identified the requirements for an advanced communications mission and the requirements for a Public Service Satellite (PSS) system. Conceivably, an advanced communications mission (operating in 4-6 and 12-14 gigahertz (GHz) bands) would provide more stringent technology drivers than the PSS mission (operating the .800 GHz band).

In each frequency band, the antenna would be configured to provide distributed multiple beam coverage throughout the continental United States (CoNUS) with scanning spot coverage to handle heavy traffic and outages. These configurations would require unblocked apertures to provide the capability necessary to meet mission requirements. It is conceivable that as many as 219 beams at 0.26° beam-width would be required. As further discussed in ref. 4, the beam crossover levels can be improved largely through the use of more than one large offset reflector. Long focal lengths ($F/D > 1$) will also be required so that coma distortion effects in wide angle beams can be minimized. Antennas for this class of applications range in size from 10 to 100 meters depending on the particular mission requirements.

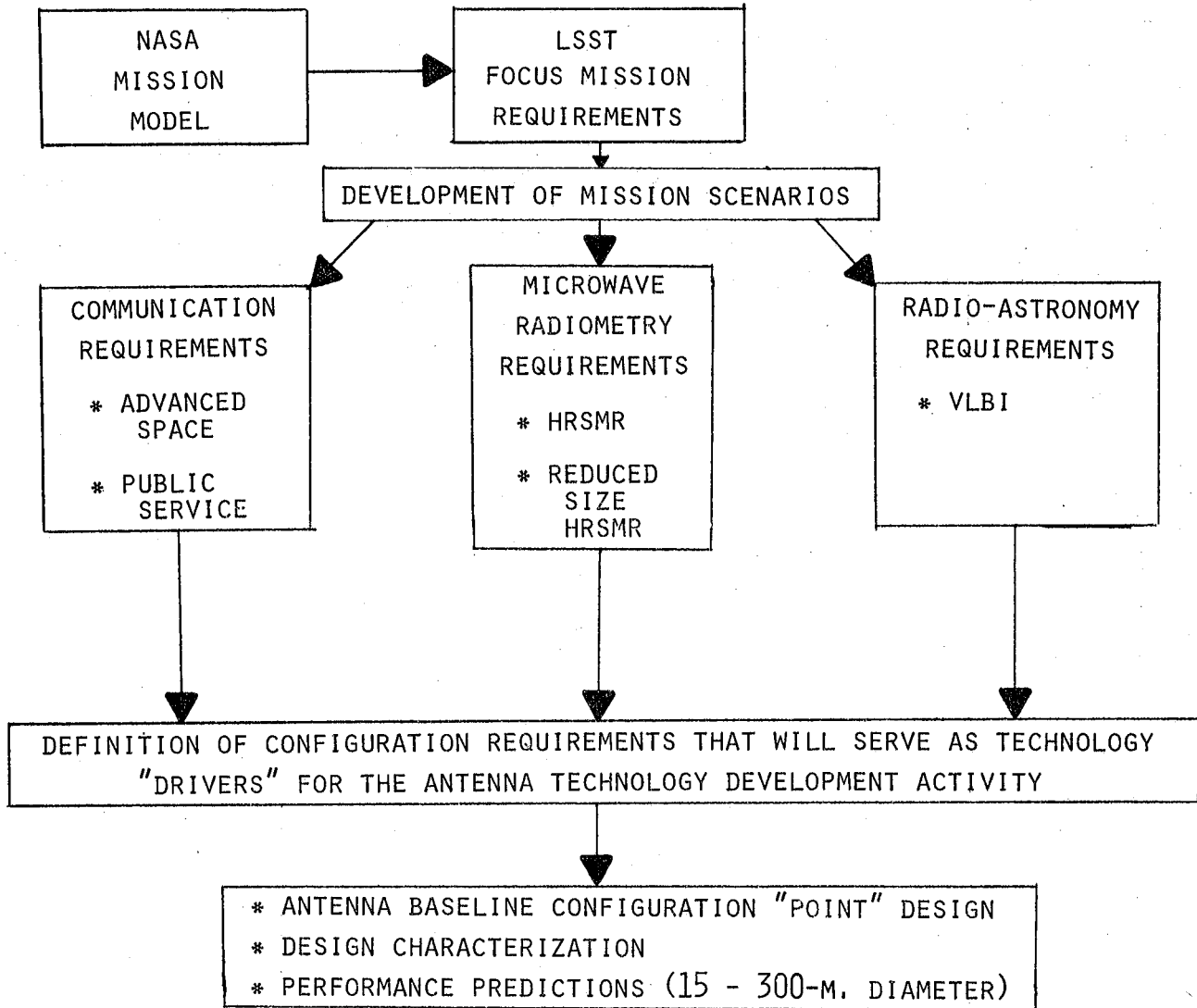

Fig. 3. LSST configuration definition approach.

The radiometer mission. During the past few years, the NASA has placed a renewed interest in the remote sensing of several earth resources and environmental parameters. Included in these areas of interest are the measurement of water surface temperature, salinity mapping, and soil moisture from low earth orbit. Based on this interest in radiometry and the development of large antenna technology, the LSST Program sponsored a Microwave Radiometer Spacecraft (MRS) conceptual design study (ref. 6) to identify characteristic configurations. This system consists of a 3-frequency radiometer: 1.08 GHz for sensing through cloud cover, vegetation,

TABLE 2 LSST Mission Scenario Summary

MISSION PARAMETER	COMMUNICATIONS				MICROWAVE RADIOMETER SYSTEM	RADIO ASTRONOMY (VLBI)
	ADVANCED		PSS***			
FREQUENCY (GHz)	4-6	11-14	0.87	2.0	1.4	1.4-22, 30
DIAMETER (M)	20	12	75	37	700	30
POINTING ACCURACY (DEGREES)	0.035	0.035	0.035	0.035	0.1	0.01
F/D	>1	>1	>1	>1	2	0.7
BEAM NUMBER	219	219	108	108	200-300	1
BEAM ANGLE (DEGREES)	0.256	0.256	0.5	0.256	0.06	FREQUENCY DEPENDENT
GAIN (dB)	60.3	60.3	60.3	60.3	68	52-76
BEAM ISOLATION (dB)	-30	-30	-30	-30	N/A	N/A
FEEDS	OFFSET				OFFSET/ ON AXIS	ON AXIS
SURFACE ACCURACY	$\lambda/20$	$\lambda/20$	$\lambda/20$	$\lambda/20$	$\lambda/50$	$\lambda/20$
ORBIT ALTITUDE	GEO	GEO	GEO	GEO	LEO	LEO
RESOLUTION (KM)	N/A	N/A	N/A	N/A	1	$10^{-5}/\text{SEC}^*$ $10^{-3}/\text{SEC}^{**}$
REVIST COVERAGE (DAYS)	N/A	N/A	N/A	N/A	3	N/A
SWATH ANGLE (DEGREES)	N/A	N/A	N/A	N/A	± 30	N/A
LIFE TIME (YEARS)	>20	>20	>20	>20	>20	>20

*TARGET

**GOAL

***PUBLIC SERVICE SATELLITE

and soil depths of 25 inches; 2.03 GHz for water surface temperature and salinity mapping; and 4.95 GHz for separating parameters with overlapping spectral signatures. In order to meet the 1-kilometer (Km) resolution requirement of the lower frequency, an effective reflector size of approximately 300-m diameter per beam at an altitude of 650 Km was required. A F/D ratio of 2.0 for each beam was selected so that an efficient beam pattern could be produced. The preliminary results from the subject scenario for such a high radiometer resolution system definitely places this mission in the far-term category. This conclusion was based on the size of the structure (≈ 660 -m diameter) that would be required to provide the 1-Km resolution at 650-Km altitude.

Other studies (refs. 1 and 7) suggest that "reduced size" or "reduced resolution" radiometric missions are feasible; however, it will be necessary to conduct additional mission definition studies so that a mission scenario assessment can be accomplished.

The radio astronomy mission. Very Long Baseline Interferometry (VLBI) techniques have been used by radio astronomers over the last decade to map celestial radio sources at previously unrealizable levels of angular resolution. Many advantages

would be obtained if VLBI observation could be performed from earth orbit. Maps of radio sources could be made faster and with higher resolution than with earth-bound VLBI's. A VLBI observatory in earth orbit becomes a compelling concept (ref. 8). The mission scenario and configuration are based on the results of a Radio Astronomy Workshop that was conducted in 1979 by the National Research Council.

After evaluating the most demanding requirements for each mission scenario, it appeared that the communications and radiometry missions would provide the most stringent technology requirements. These requirements were used so that baseline antenna configurations could be used to aid identification and selection of candidate concepts for LSST development.

LSST ANTENNA TECHNOLOGY ASSESSMENT

Once the requirements for the LSST focus missions and resulting mission scenarios had been developed, a technology assessment was conducted. This assessment included: (1) development of selection criteria, (2) evaluation of promising concepts, and (3) performance projections for concepts. The results of previous antenna development activities and technology assessment studies were determined to be sufficient for conducting this assessment.

Concept Selection Criteria

The criteria used to aid in the assessment and selection of specific concepts is a function of many factors. The relative importance of these factors is a function of the specific application under consideration. Therefore, the following listing does not imply a ranking of any kind: (1) surface precision in the intended service environment, (2) mechanical packaging efficiency, (3) maturity of concept, (4) cost, (5) weight, (6) refurlability, (7) applicability for active surface control, (8) deployment reliability, (9) dynamic characteristics, (10) concept growth potential, (11) applicability to ground-based evaluation, and (12) applicability of concept for different applications.

Concepts Selected for Development

A comprehensive report (ref. 9) was generated in 1978 which described nondeployable, precision deployable, mesh deployable, and erectable antenna concepts. A detailed description was presented, accompanied by illustrations, of 19 different concepts that were based on data provided by each developer. Estimates of surface precision, packaging efficiency as applicable, and weight as a function of antenna size were provided. This report, and two companion papers (refs. 10 and 11) which contain the details of the LSST antenna technology assessment activities, suggests that the mesh deployable antenna concepts could satisfy the near-term (mid-1980's) mission requirements.

The state of the art of deployable antenna technology was assessed using the factors identified in the selection criteria. Through this process, candidate concepts were selected by the LSST Program for subsequent development.

The specific mesh deployable antenna concepts identified as having the potential capability of satisfying the LSST requirements are the wrap-rib antenna from Lockheed Missiles and Space Company (LMSC) and the maypole (hoop/column) antenna from the Harris Corporation. For familiarization purposes, a brief overview of each concept is described below.

Wrap-rib antenna. LMSC has developed the wrap-rib antenna concept (Fig. 4) to the point of flight applications for many different sizes of antennas.

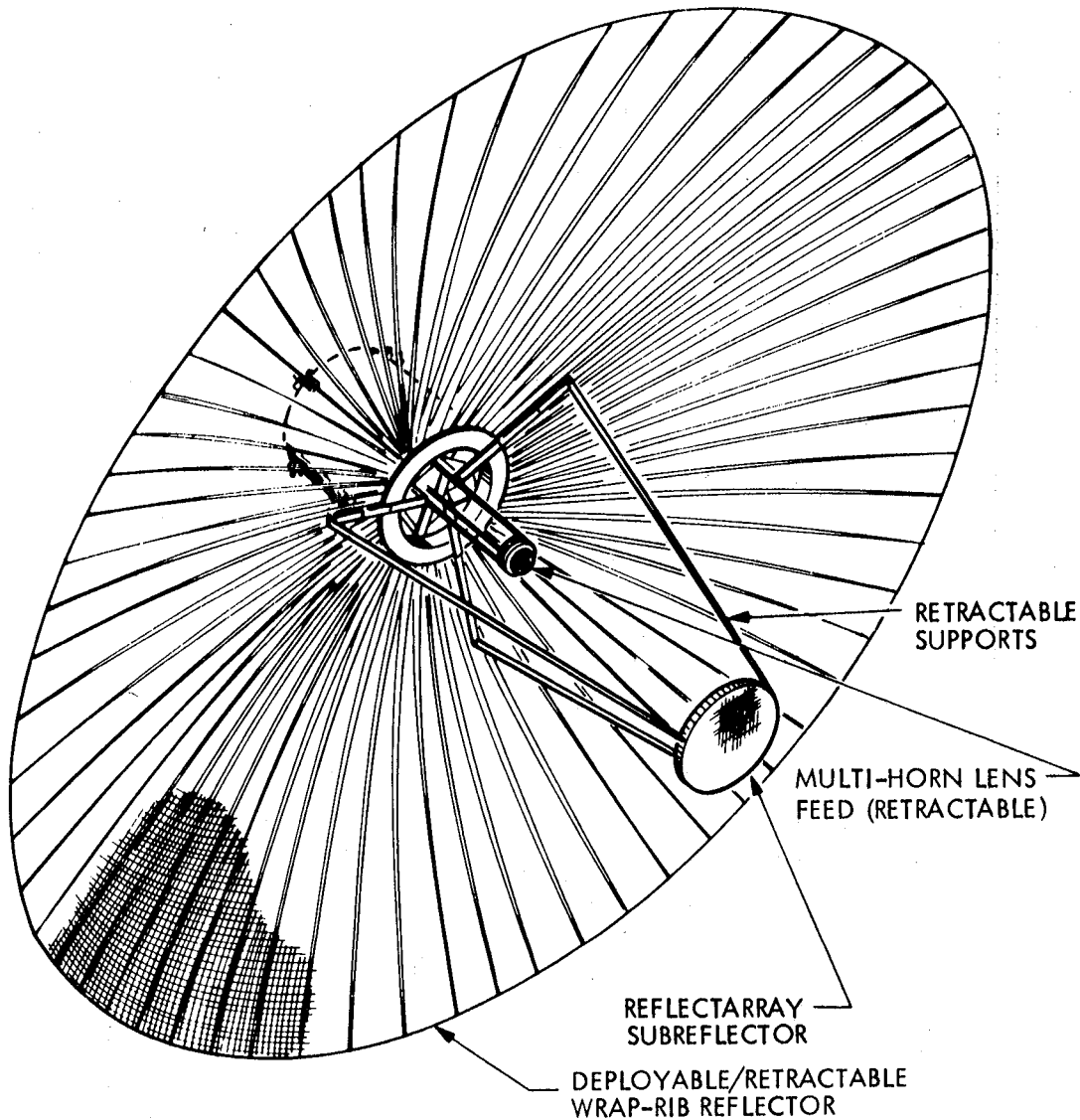

Fig. 4. Wrap-rib antenna concept.

The best known application is the Applications Technology Satellite 6 (ATS-6) spacecraft which uses a 9.1-m parabolic, wrap-rib antenna (Fig. 5) operating up to and above 8 GHz. The ATS-6 antenna, made with aluminum ribs and conventional thermal blankets, represents a technology that is about 14 years old. Recent developments using this concept have resulted in a manufacturing capability for fabricating wrap-ribs from composite materials with extremely low coefficients of thermal expansion (CTE). New materials and processes for manufacturing mesh have been developed recently, and the analytical capability for the detailed design of the structure has been improved. These developments have made it possible to design, build, and predict antenna performance for wrap-rib structures up to several hundred meters in diameter, and perhaps larger, for operation up to and possibly above X-band.

The wrap-rib antenna configuration is based on a variable number of radial ribs or beams which are cantilevered from a central hub structure. The ribs which support the mesh can be shaped to accommodate flat, conical, parabolic, or hemispherical antennas. The rib cross section and material were chosen to permit the

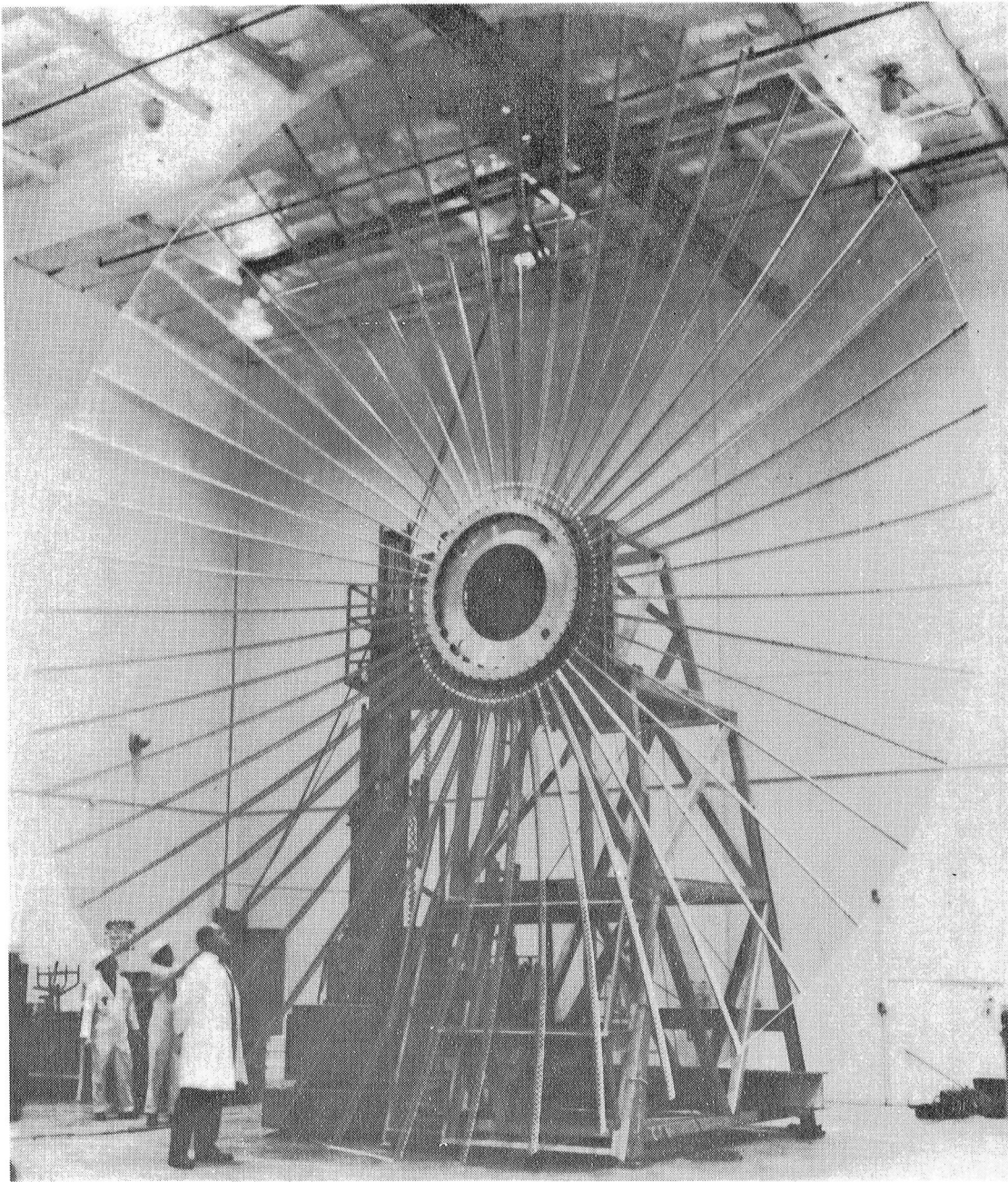

Fig. 5. ATS-6 flight antenna.

elastic buckling of the ribs. This will allow the ribs to be elastically wrapped around the hub structure in the stowed package configuration (Fig. 6). In stowing the antenna, the ribs with the RF reflective mesh gores folded between them are rotated about the rib root hinges until the ribs are tangent to the hub. After this initial rotation, the ribs are wrapped completely around the hub.

Antenna deployment is accomplished for small size systems (less than 25 m in diameter) by release of strain energy in the ribs. For the large size antennas, a deployment restraint system is employed that uses a tape and pulley system (Fig. 6). With this system, a tape is placed between each rib, such that the tape under tension keeps each rib wrapped around the hub.

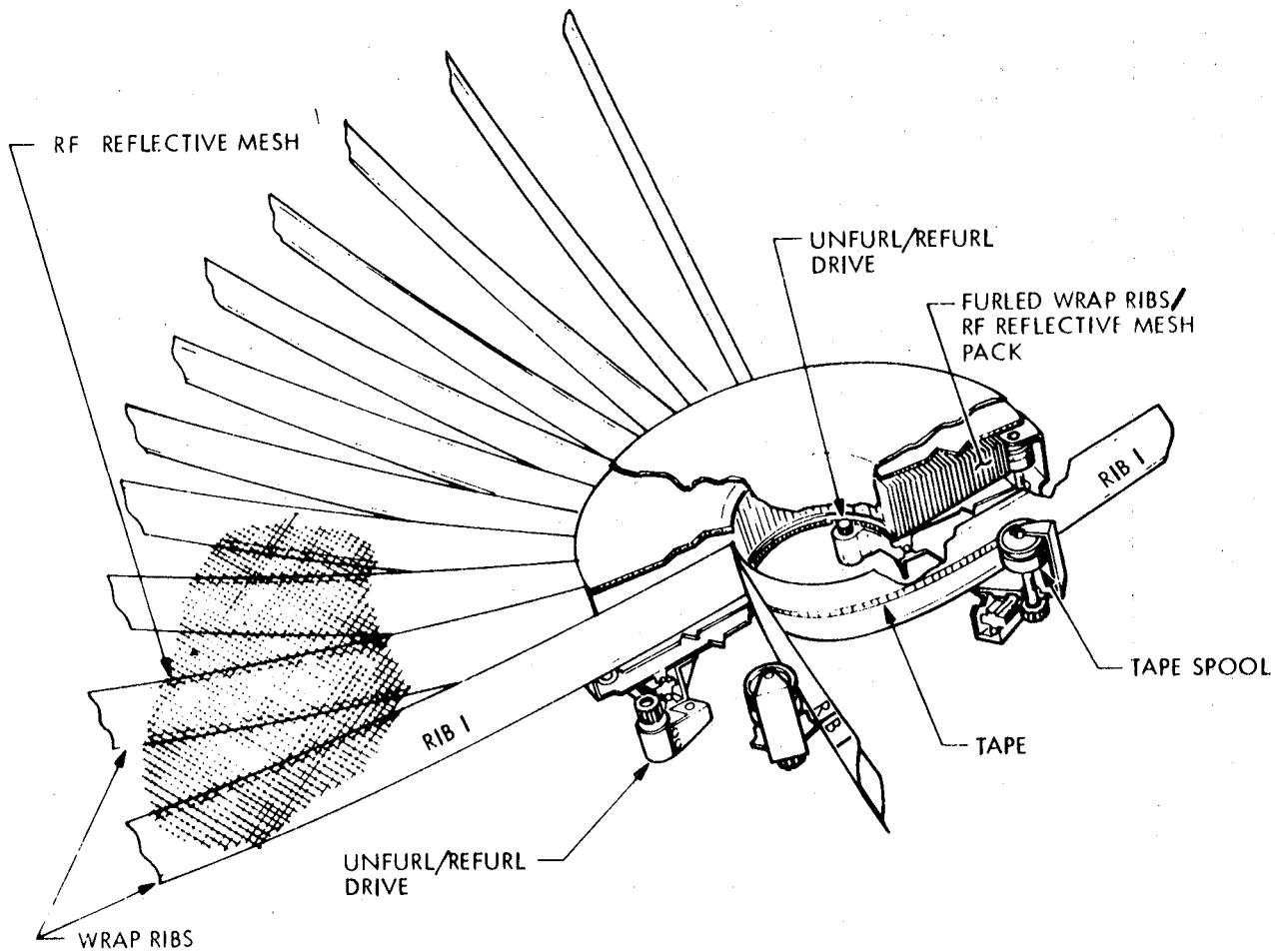

Fig. 6. Wrap-rib antenna deployment mechanism.

Maypole (hoop/column) antenna. During the past ten years, the Harris Corporation has developed a radial-rib, double-mesh deployable antenna for space application. The required antenna surface tolerance is achieved through the use of a secondary drawing surface technique. This technique has been developed and demonstrated in the Tracking and Data Relay Satellite System (TDRSS) antenna design. An offspring of the radial-rib technology using the secondary drawing surface approach has been the definition of a hoop/column deployable antenna concept.

The hoop/column deployable antenna concept is a type of maypole configuration that provides a unique technique for contouring the RF reflective mesh. Basically, the hoop/column concept as illustrated in Figs. 7 and 8, is a cable-stiffened structure that uses a secondary drawing surface to produce the desired surface contour. Actually, flat, conical, parabolic, or spherical surfaces can be produced using the secondary drawing surface technique. This concept was developed to a feasibility level during the Advanced Applications Flight Experiment (AAFE) Program (ref. 12) as preliminary designs for 15-, 30-, and 100-meter diameters were generated. The deployment sequence for the AAFE hoop/column design is shown in Fig. 9.

During the AAFE study effort, a 1.8-m demonstration model was used to verify the basic conceptual design and to aid in developing the deployment kinematics. This effort was complemented with the development of analytical techniques for predicting the performance of these large deployable structures.

The fundamental elements of this antenna structure include: the hoop; upper, lower, and central control stringer; and the telescoping mast. A more detailed description of the hoop/column critical elements will be described later.

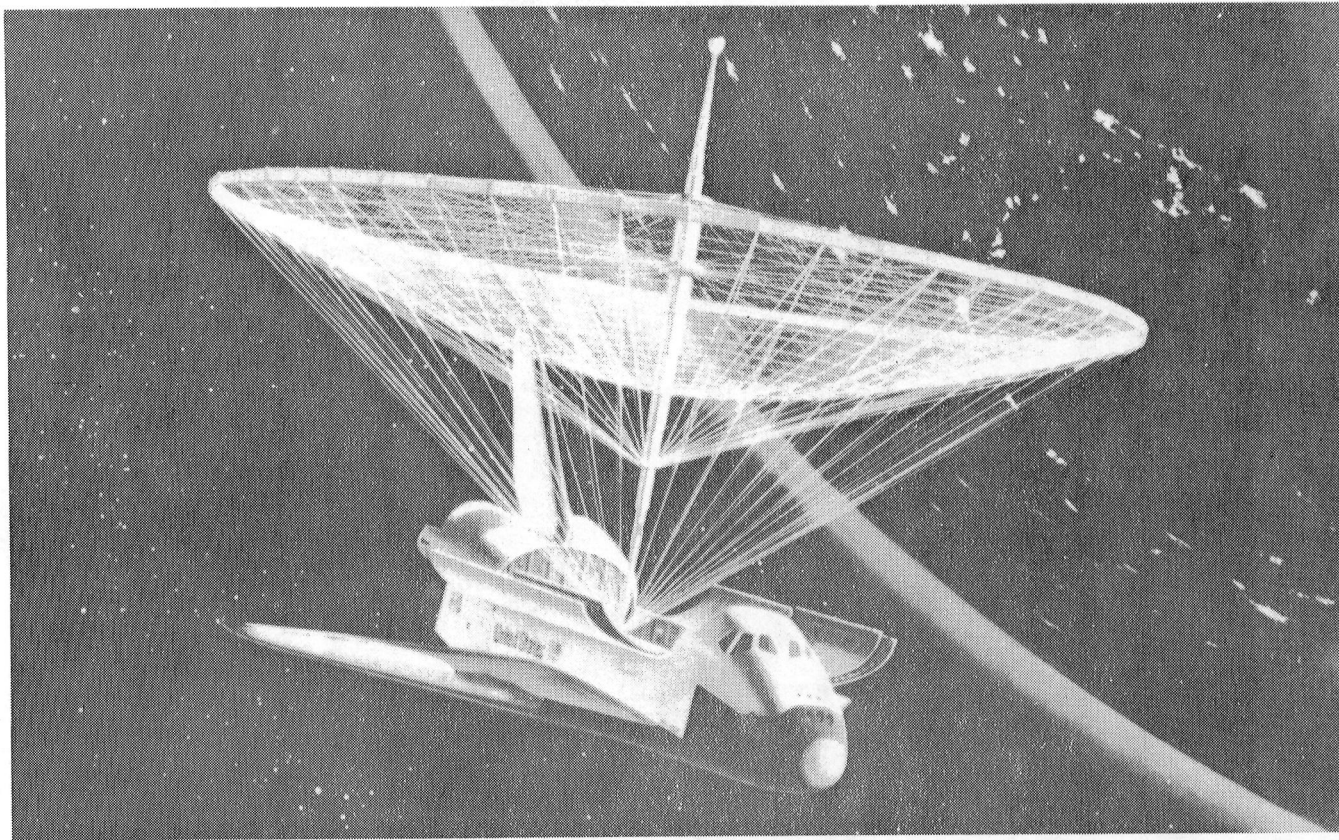

Fig. 7. Maypole (hoop/column) antenna concept.

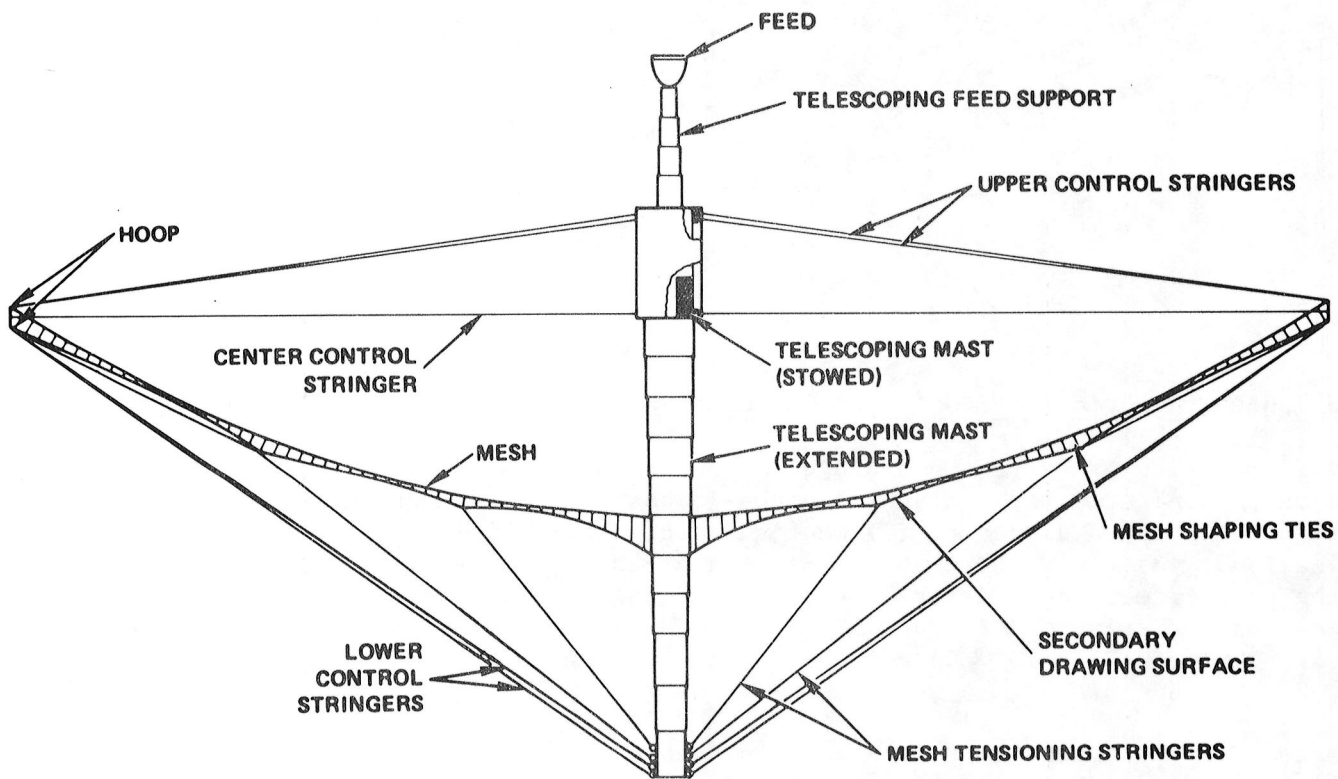

Fig. 8. Maypole (hoop/column) antenna concept elements.

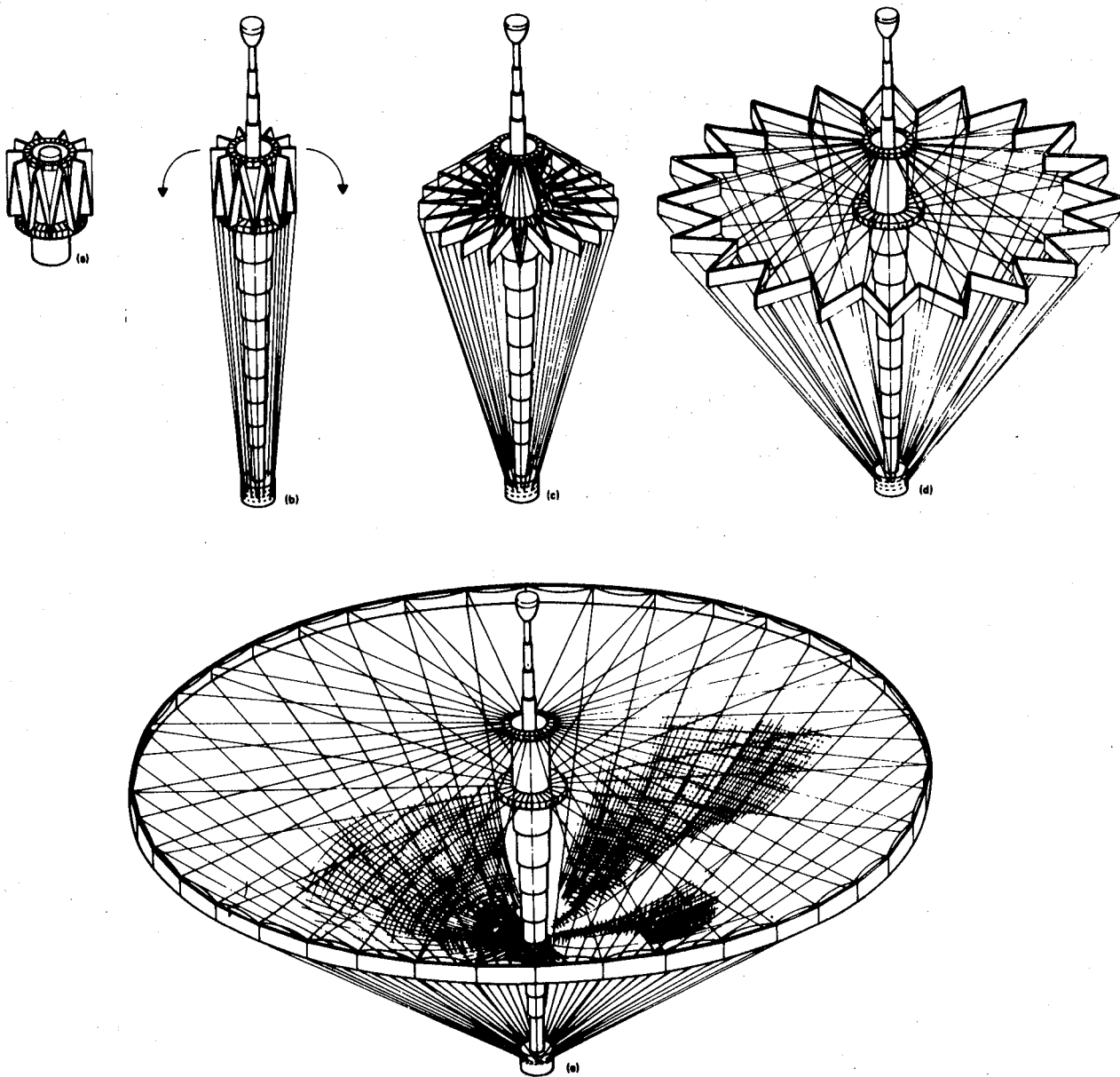

Fig. 9. Maypole (hoop/column) deployment sequence.

Performance Projections for Selected Concepts

The determination of current and projected performance for deployable antennas was based on the selection criteria with emphasis on: (1) surface precision as a function of deployed diameter, (2) configuration applicability for offset feed applications, (3) the maturity of concepts and designs under consideration, and (4) the time frame required for development of the technology to the point of applications. Estimates of deployable antenna surface quality as a function of size are given in Fig. 10. Data for the characterization was obtained from refs. 9, 12, and 13.

Estimates for the upper limit for mesh deployable antenna surface accuracy is given by line segments A, B, and C of Fig. 10 and can be read directly as a function of diameter. The surface quality represented by line segment A is based on a composite of demonstrated and estimated performance for current mesh deployable

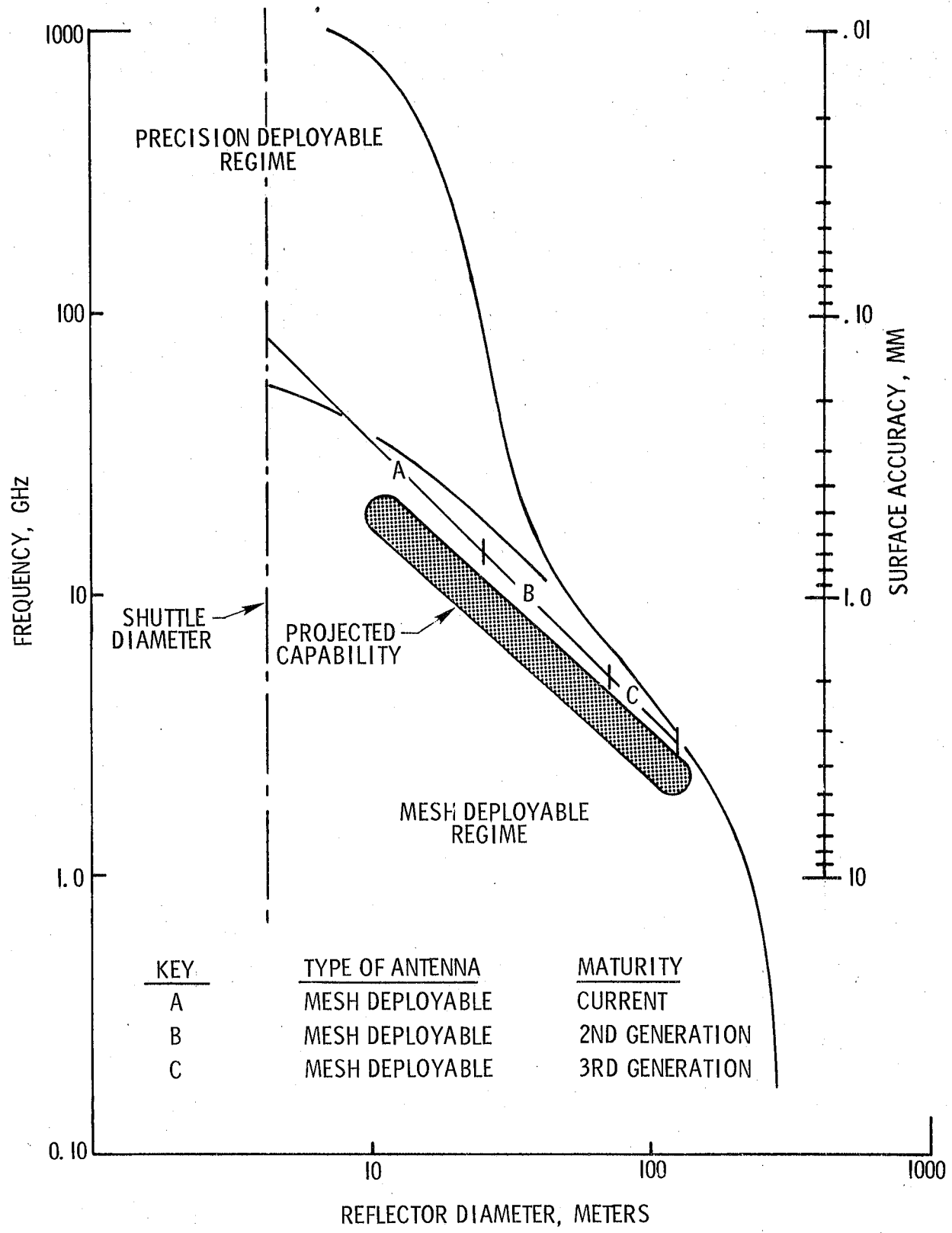

Fig. 10. Projected performance for mesh deployable antennas.

antenna capability. The demonstration of this technology is based on results of models, components, full-scale testing, analytical predictions of full-scale performance, and flight experience for some designs. Line segments B and C represent estimates for performance for the next two steps of technology development, which are based on the assumption that the ratio of surface quality to deployed

diameter can be kept constant. The upper limit for frequency range of operation for the indicated surface precision (based on an equivalent surface roughness of approximately $\lambda/20$ where λ is wavelength of operating frequency) is given as a function of diameter for purposes of reference. The surface qualities given in line segments A, B, and C are for the "as manufactured" case, which includes approximation loss and manufacturing tolerances. This does not include thermal distortion and interaction of the structure with the control systems and external disturbances. These considerations are dependent on the configuration, materials used, and the specific application.

In order to characterize on-orbit mesh deployable antenna performance, estimates of worst-case thermal distortion were obtained for the Harris maypole and the Lockheed wrap-rib antenna, and plotted as a function of surface precision and diameter. This is shown in Fig. 10 as the shaded projected performance area. The reduction of operational frequency as a consequence of accounting for the thermal distortion is evident. However, the actual antenna surface quality for a specific application may be different because of the structural configuration, the materials used, and the particular service environment. Therefore, the actual on-orbit operating capability will be determined when an actual mission is conducted.

OFFSET WRAP-RIB ANTENNA PROGRAM

Introduction

Design study. The potential value of the wrap-rib deployable antenna concept is a function of many variables. One of the most important variables (with respect to focus-mission requirements) is the feed configuration. Previous wrap-rib antenna technology demonstrations have been based on axisymmetric feed configurations (refs. 9 and 14). However, since the focus mission requirements and scenarios identified the need for unblocked aperture antennas, the applicability of the basic wrap-rib concept for offset fed configurations became a significant issue. For this reason, the initial development of the subject concept was focused on determining the applicability of the basic design for offset feed configurations. The impact of changing feed configurations was evaluated in terms of reflector surface quality, cost, weight, mechanical complexity, and mechanical packaging efficiency for antenna structures up to 300 meters in diameter. This determination was accomplished by LMSC during 1979 by developing a configuration design of the offset feed structure which was the basis of an analytical model used for the evaluation (ref. 15).

Design study results. The most significant results of the analytical investigation indicated that axisymmetric technology for the reflector structure is directly applicable for offset configurations with small impact to cost and technical risk (ref. 15). A major impact resulting from changing the feed configurations is the difference in the deployable feed support structure. Typical single beam focal feed antennas utilize a simple tripod or mast originating at the perimeter of the hub structure, and terminating at the focus of the reflector (with a simple feed horn or a small subreflector). This type of deployable support is structurally and thermally quite stable (Fig. 11). The deployable feed support structure for the offset configuration can only be hard mounted to the reflector hub structure. The resulting configuration is a cantilever boom originating at the antenna hub with a straight section approximately equal in length to the reflector radius, then a 90° change in direction to another straight boom, that is 1.5 times the diameter of the reflector (Fig. 12). The development of such a feed support structure will be based on compatibility with the existing wrap-rib reflector technology. The implementation and deployment sequence of the offset wrap-rib antenna is shown in Fig. 13.

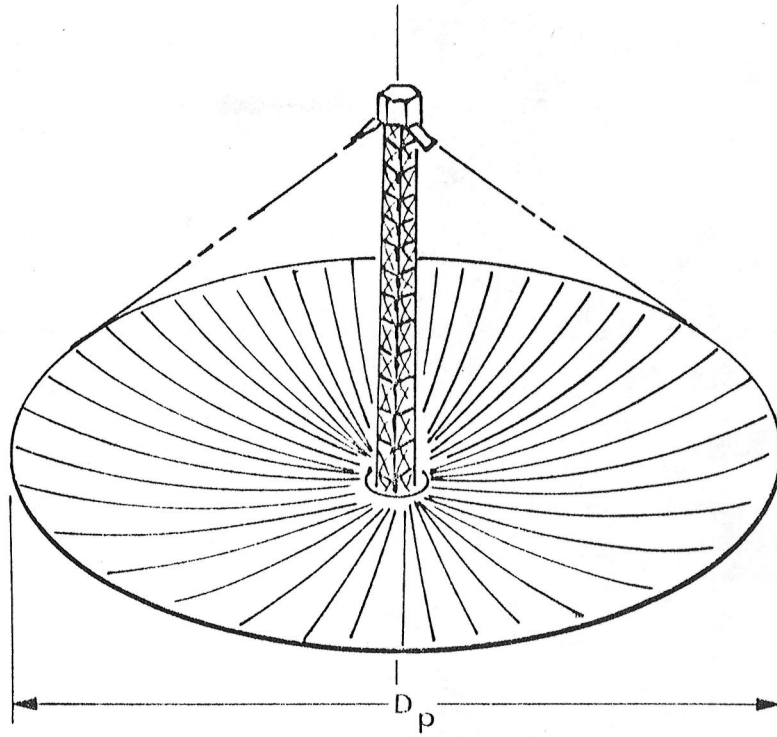

Fig. 11. Typical axisymmetric parabolic antenna system.

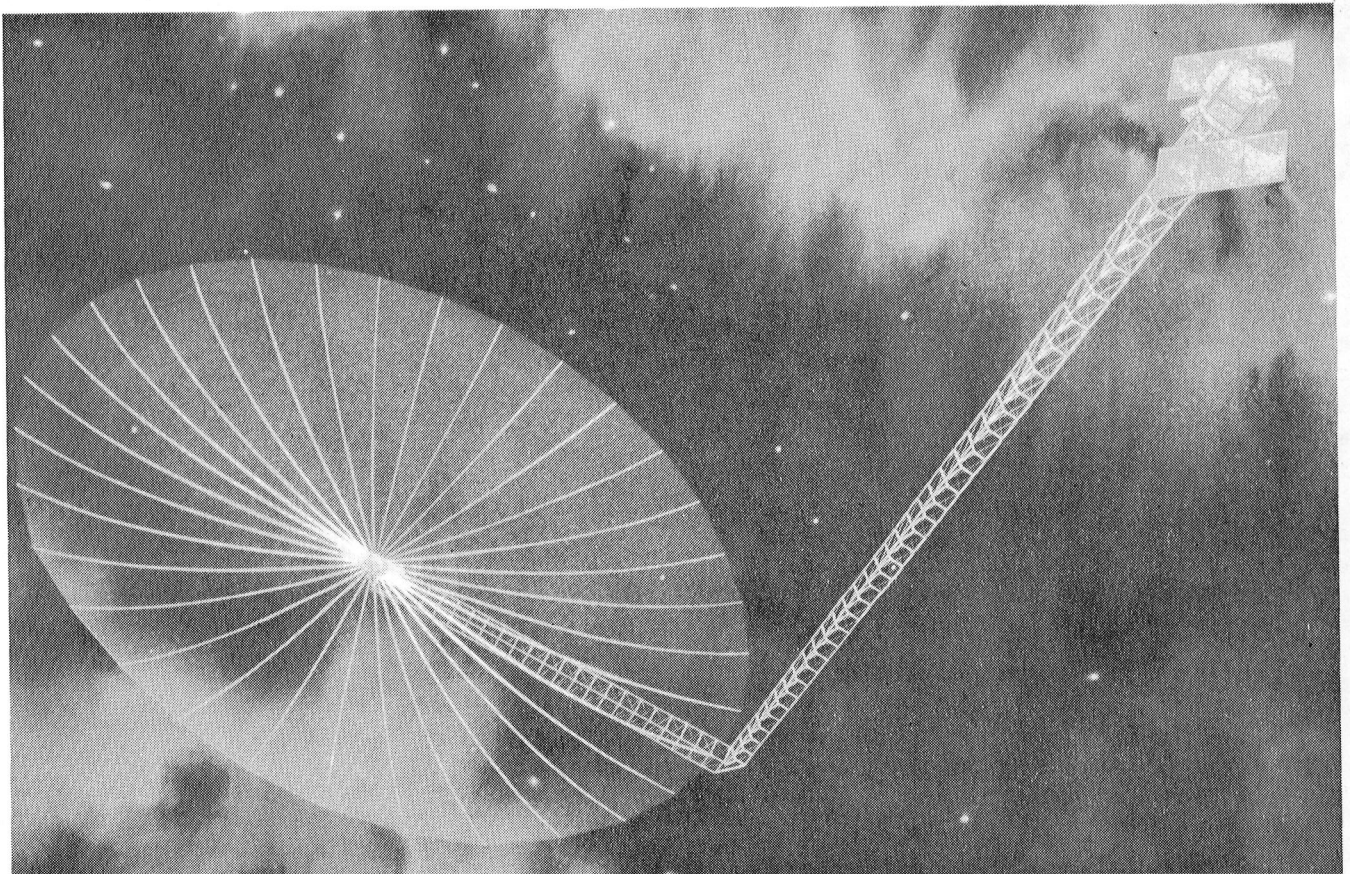

Fig. 12. Offset wrap-rib antenna.

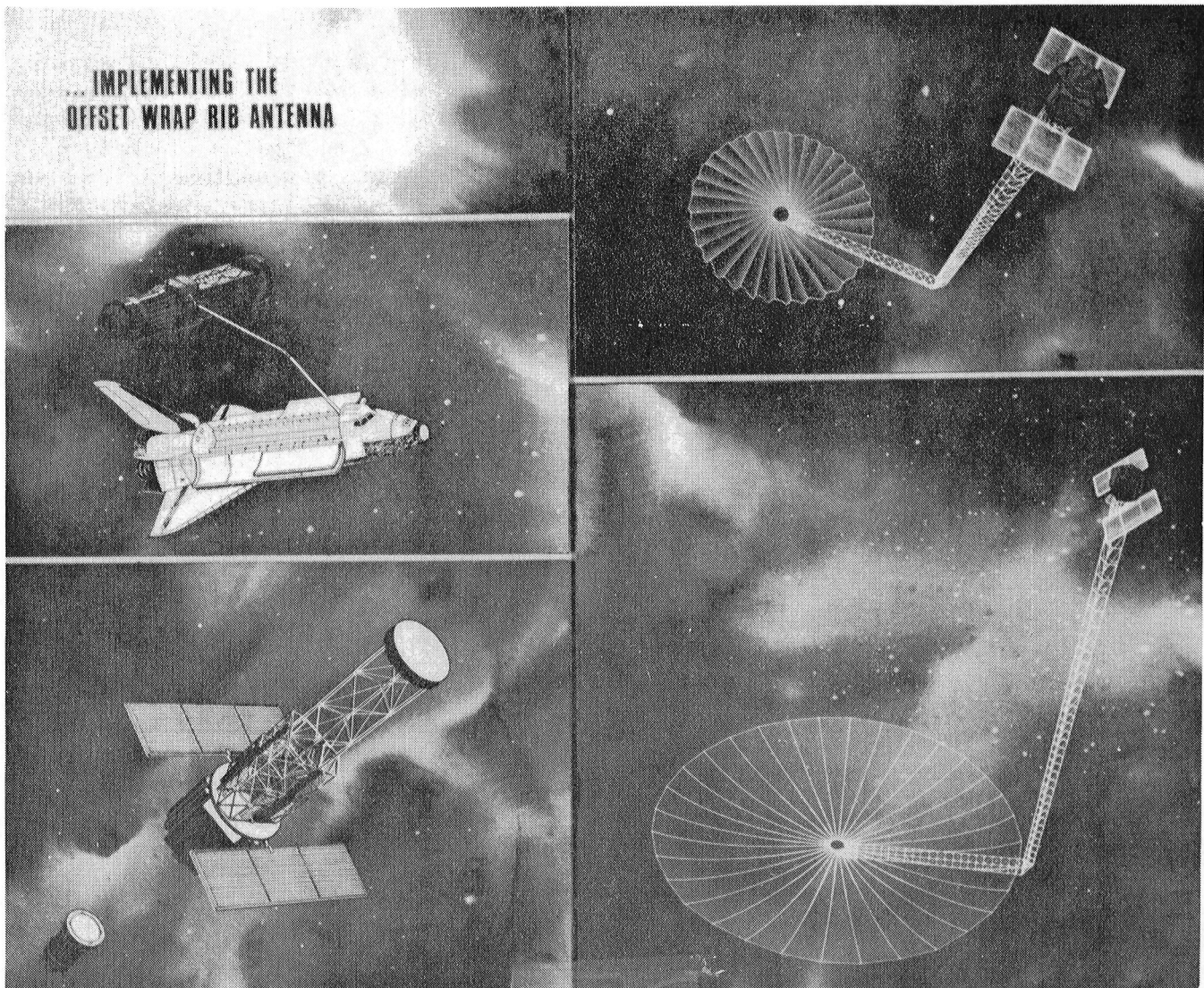

Fig. 13. Offset wrap-rib antenna implementation and deployment sequence.

Additional important results of the analytical design evaluation showed: (1) offset wrap-rib antennas (up to 150 meters in diameter) are feasible for operation at 2 to 3 GHz, (2) STS compatibility is not a significant design driver, (3) the most significant contributions to reflector surface errors that limit RF performance are thermal distortion and surface approximation, (4) determination of the potential benefits of active surface control should be pursued, and (5) cost and technical risk associated with developing large offset reflectors (i.e., 100 to 150 meters in diameter) could be significantly reduced by establishing a data base for 50-m diameter technology. The details of these results are as follows:

1. Large offset antennas feasible: Estimates were made for the upper bounds of surface quality for the symmetric and offset reflector designs as a function of diameter (Fig. 14). The limit for frequency of operation was defined as the total Root-Mean-Square (RMS) error allowable when equivalent to 1/30 of the operating wavelength. Surface errors included: (a) surface approximation, (b) thermal distortion, (c) rib contour manufacturing, (d) rib assembly, (e) reflector assembly, and (f) graphite epoxy viscoelastic creep. It is interesting to note that constraints on achievable operating frequency are design induced (i.e., number of ribs and thermal distortion) for diameters less than 95 meters and STS constrained, (i.e., rib limiting effect of STS diameter) for apertures larger than 95 meters. The resulting curve, along with previous LMSC experience, indicates that offset antennas up to 150 meters in diameter are feasible for operation at 2 to 3 GHz.

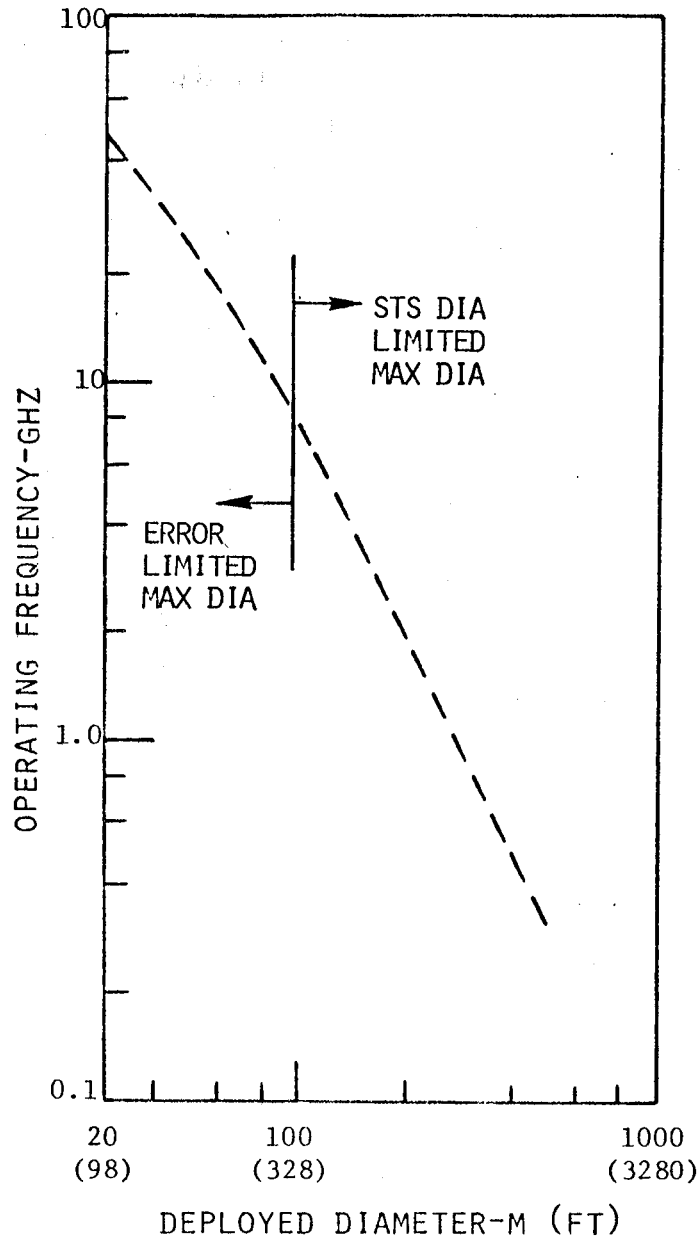

Fig. 14. Offset wrap-rib upper limit of surface quality.

2. STS compatibility: The stowed diameter of the reflector and feed structure for the antennas of interest (i.e., up to 300 meters in diameter) does not exceed the 4.57-meter diameter limit of the STS bay. Figure 15 displays the stowed package length for the reflector and feed support structure. The results indicated that there is no significant STS volume constraint imposed on the growth of the concept in the size range of interest.

3. Reflector surface error sources: Of the total error sources contributing to the reflector surface, thermal distortion and surface approximation are the dominant contributors for the size antennas evaluated (Figs. 16 and 17). The reason for the lower surface approximation loss for the offset reflector as compared to the symmetric reflector is the effectively larger F/D ratio for the offset configuration. The feed support structure does not limit the RF performance due to feed-induced beam shift until the focal length is increased to about three times the actual section diameter of the offset geometry.

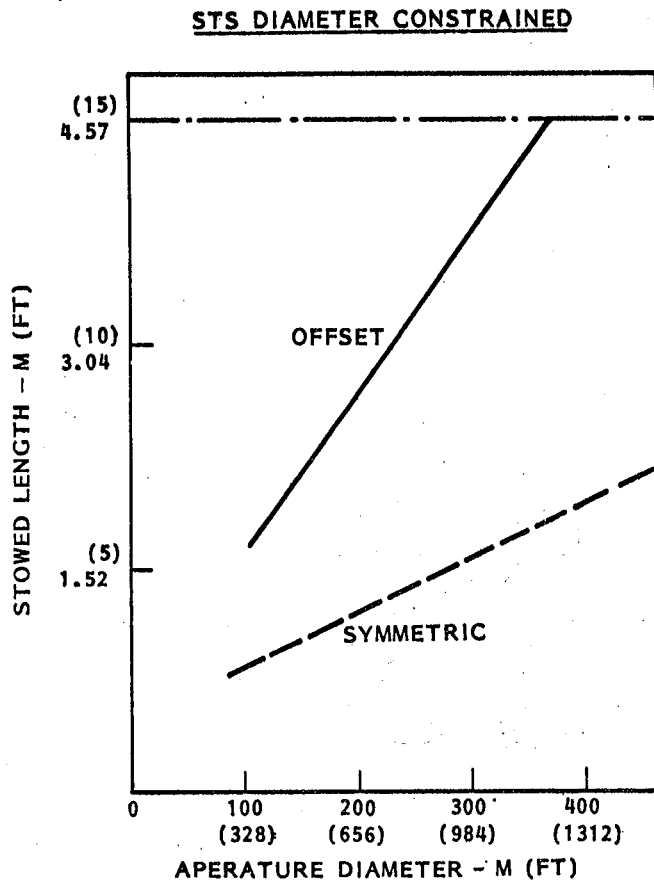

Fig. 15. Wrap-rib stowed diameter characteristics.

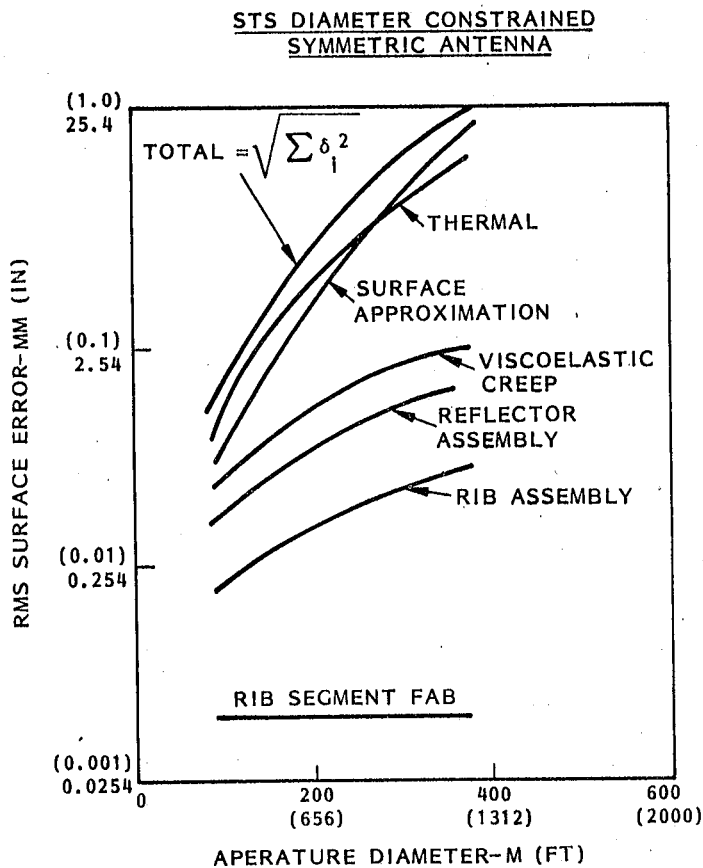

Fig. 16. Wrap-rib surface figure characteristics--symmetric antenna.

STS DIAMETER CONSTRAINED
OFFSET ANTENNA

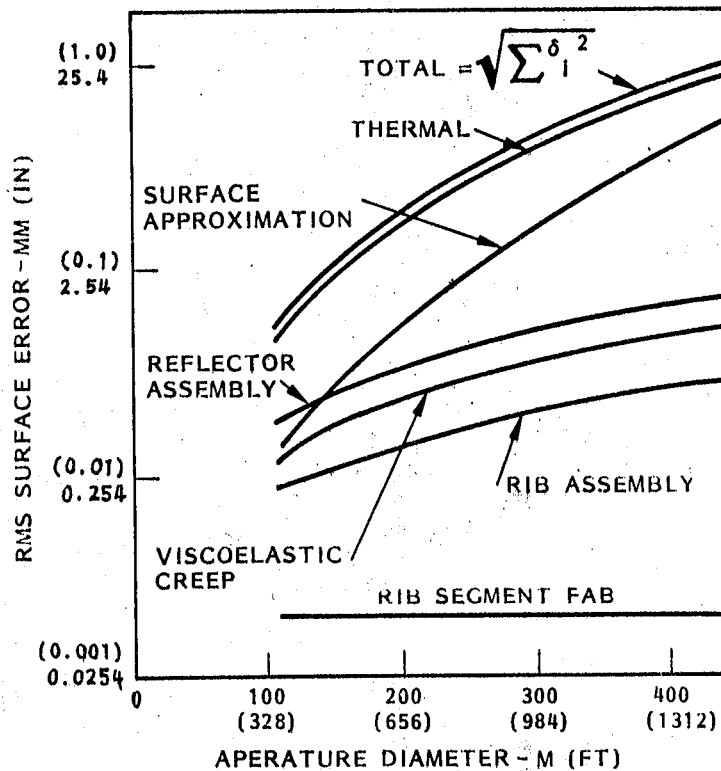

Fig. 17. Wrap-rib surface figure characteristics--offset antenna.

4. Reflector surface adjustment: The basic cantilever configuration of the wrap-rib reflector structure lends itself to mechanization for an orbit adjustment of individual ribs. Current antenna hub designs can accommodate mechanization for radial and axial translation and rotation of individual ribs at the antenna hub structure. Such adjustments would be based on error signals from a controller utilizing an automated surface contour measurement system. This method of surface adjustment would be intended to correct surface errors resulting from hardware assembly and thermal distortion. A detailed evaluation of this method of adjustment through analysis and hardware testing is required to establish the potential value of this particular technology.

5. Risk assessment: The results of the study indicate the potential for large offset reflector structures. These projections are based on an understanding of the basic design of the large size antennas (i.e., 100 to 150 meters) and an understanding of the detail design and fabrication of the smaller size structures (i.e., 16 meters). The specific concerns associated with building the large size antenna structure include: (a) manufacturability of large components, (b) assembly alignments facility requirements, (c) lack of 1-G testability for surface contour, and (d) verification of analytic performance prediction models. The nature of these concerns suggests that a new data base be established by developing, fabricating, and assembling components for a large antenna structure. Only by the actual production of large size hardware can the techniques required for tooling, fabrication, and assembly be developed; and only by the deployments of very large hardware models can the problems associated with deployment verification in a gravitational environment be understood and solved.

Concept Development Objective

Criteria for new data base. The antenna hardware model selected as the basis for a new data base should: (1) extend the current and proven data base of 16 meters to the largest practical size, (2) address the same basic set of problems to be faced by building full-size antennas, (3) be large enough so that extrapolation from the new data base to full-size antennas can be done with confidence, (4) be representative enough of full-scale designs to accommodate direct scaling, (5) lend itself to ground-based evaluations, and (6) be of sufficient hardware quality to accommodate the completion of fabrication for a flight demonstration and/or application article.

The criteria established for defining the new data base hardware suggests that the selection of the largest practical diameter (partial offset reflector antenna) structure that can be accommodated by current funding and technology limitations is 55-meters in diameter. The partial antenna would be composed of four full-size ribs, three mesh gores, a hub structure, and a deployable feed support structure. The selection of 55-meter diameter for the hardware represents an increase in size by a factor of 3.4 with respect to current wrap-rib antenna hardware demonstrations. The development of this size hardware will address the same basic problems associated with fabricating full-scale antennas (i.e., 100 meters in diameter). Previous LMSC developments associated with splicing techniques for flexible ribs suggests that fabrication of ribs for such large size antennas is commensurate with current capability. By fabricating and evaluating ribs this size, the projection of full-scale performance will then be based on a scaling factor of only 1.8. Additionally, the 55-meter diameter partial antenna can be accommodated by existing LMSC ground-handling facilities for assembly, alignment, and rib deployment.

Objectives for new data base. The specific objectives and goals established for the new data base include:

- o Demonstration and evaluation of deployment of a 55-meter diameter antenna;
- o Demonstration and verification of large size antenna fabrication, assembly, and alignment techniques and procedures;
- o Verification of the stability and durability of the mesh, ribs, deployment mechanisms, and feed-support structure by repeated deployments;
- o Development and verification of tooling for rib and mesh gore assembly;
- o Verification of the predicted packaging densities of the ribs and mesh gore assemblies;
- o Verification of the deployment envelope of the reflector and feed support structure; and
- o Verification of analytical models used to predict full-scale antenna performance.

Concept Development Program

The current LSST sponsored technology development of the offset wrap-rib antenna is based on the generation of a new 55-meter data base and is focused on: (1) reflector structure development, (2) feed support structure development, (3) reflector surface adjustment capability development, (4) analytical performance and prediction capability development, (5) ground test of 55-meter model, and (6) preliminary "point design" of 100-meter diameter antenna. This plan (Fig. 18) is directed toward a ground-based technology demonstration of 55-meter antenna capability during 1982 and technology readiness by 1984.

Reflector structure development. The reflector structure consists of the ribs, hub assembly, and mesh. The ribs for the offset reflector will be based on graphite

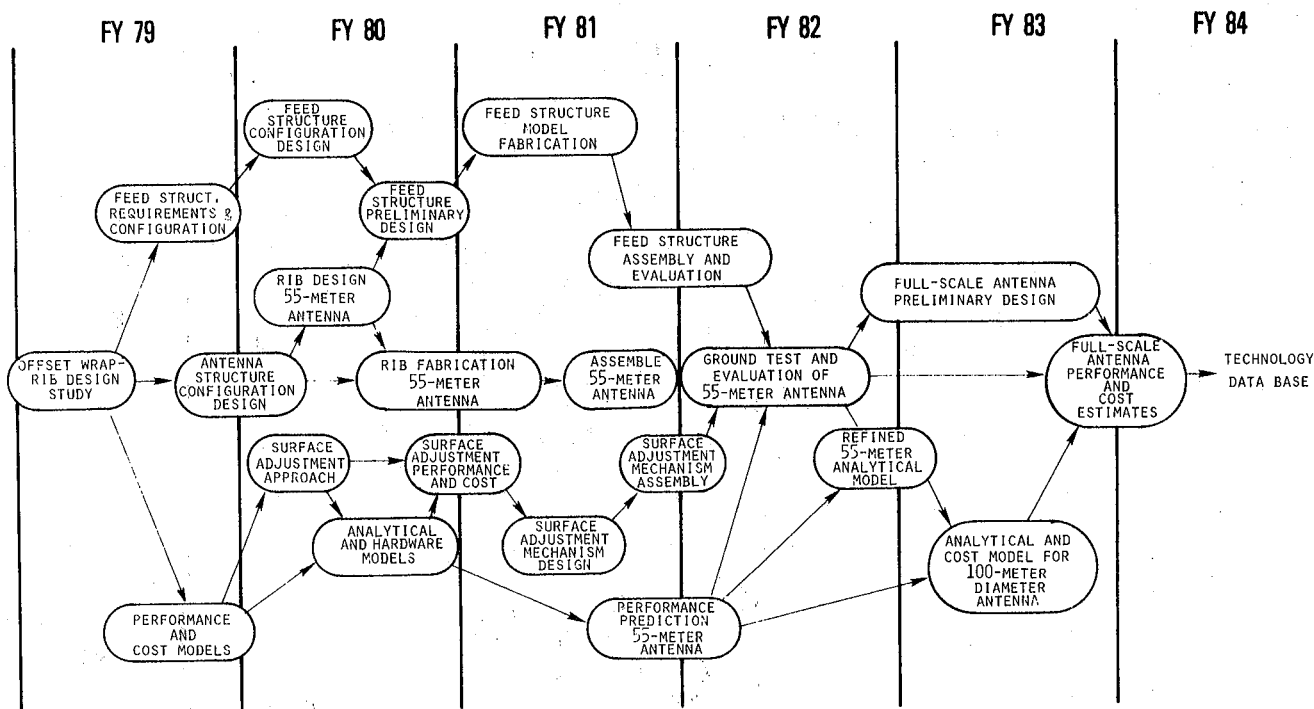

Fig. 18. LSST offset wrap-rib technology development plan.

epoxy technology because of: (1) improved thermal and stiffness properties as compared to aluminum (which was used on the ATS-6), and (2) the level of maturity of this technology. The cross section of the ribs will be full lenticular (refs. 13, 16, and 17); the shape required for the larger size antennas (Fig. 19). The maximum

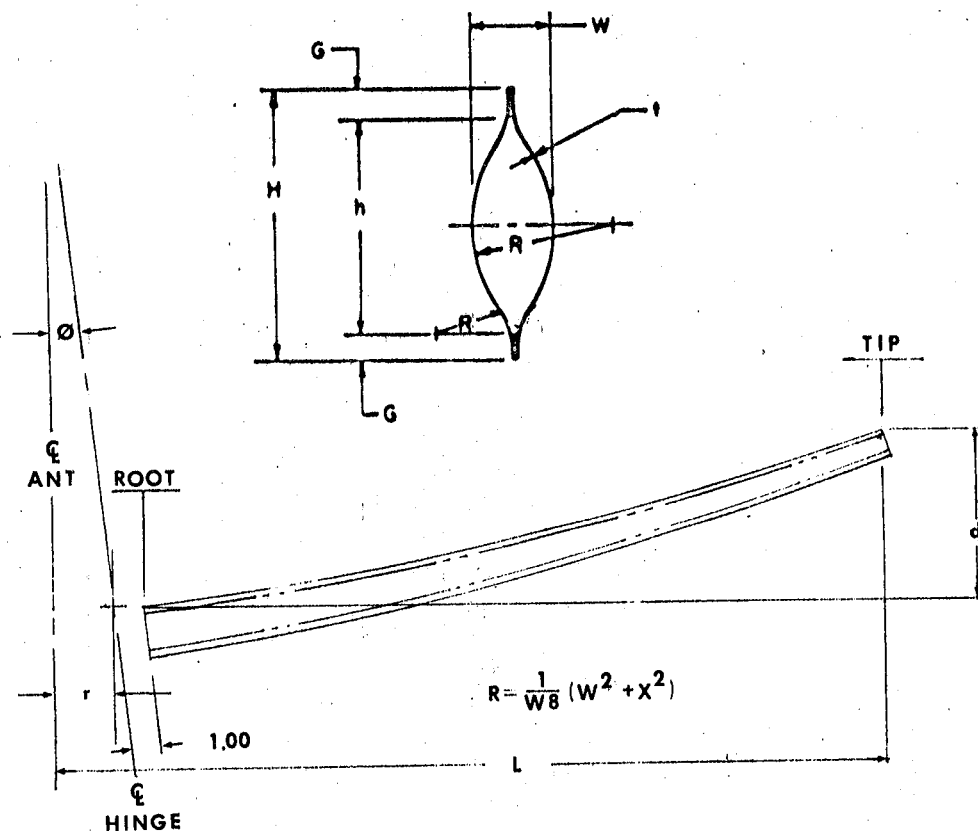

Fig. 19. Wrap-rib lenticular rib cross section.

length of a single rib segment is limited to approximately 6 meters by current manufacturing support equipment capacity. Therefore, the ribs are made in segments, which are spliced together after machining, for the final product. The tooling for the individual rib segments produces half sections which are bonded together to form the complete rib. Since the rib has a tapered cross section, several sets of different tooling will be required for a single rib. Even though the offset reflector has only planar symmetric pairs of ribs, by leaving a sufficiently large lip on the basic rib to accommodate the machining of different curvatures, the same tooling can be used for all the ribs.

The application of metal matrix composites such as graphite/magnesium or graphite/aluminum for the wrap-rib structure (ribs) will improve antenna performance when compared to the graphite/epoxy technology (refs. 11, 17, and 18). This metal matrix technology, which is currently under development at LMSC, is expected to be sufficiently mature by 1983 to accommodate the fabrication of very large antenna ribs.

The hub structure will be sized so that the packaged reflector can be accommodated by the STS payload compartment or a conventional expendable booster. The counter rotating design will provide for controlled deployment of the ribs along with a refurling capability.

The mesh selected is a two-bar, tricot knit, gold-plated molybdenum wire (Fig. 20). The density (i.e., number of wires per inch) is a function of the RF of the antenna (ref. 19). This mesh is used on the large reflector antennas because of its relatively low stiffness. Because of the low stiffness, the mesh can maintain a two directional tension field (while the antenna experiences large thermal changes) without imparting a large load to the rib structure. The edges of the mesh are terminated by bonding to a kevlar fabric strip which is in turn attached to the rib structure. A series of tension ties, made from single strands of invar wire, will be used with the mesh and attached to adjacent ribs. These cord assemblies, spaced about one meter apart along the length of the ribs, will depress the mesh pillowing, which results from the tension in the mesh in the radial direction.

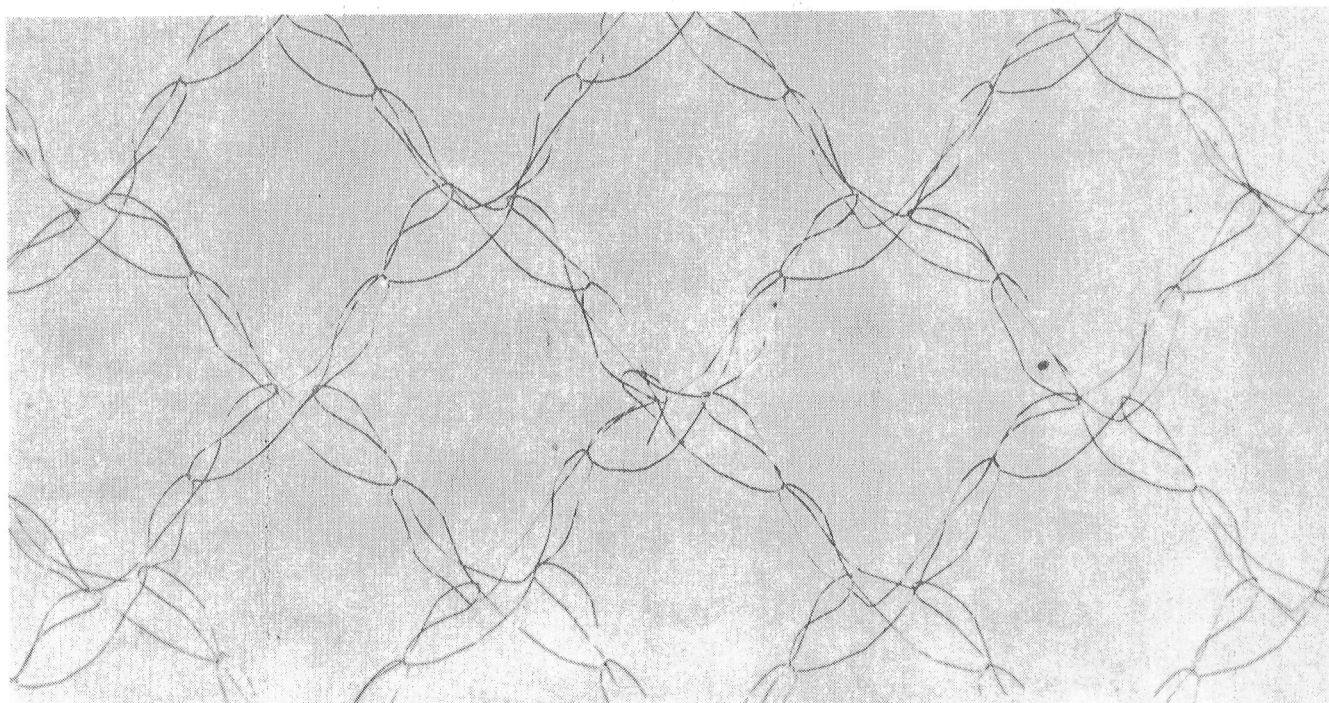

Fig. 20. Moly/gold knit mesh.

Feed support structure development. The development of the deployable feed support structure for the offset reflector represents an entirely new technology. The requirements for the development are based on the potential capability of the offset reflector structure. These requirements include: (1) good mechanical packaging efficiency, (2) thermal stability, (3) structural stiffness, (4) low weight, (5) long-term dimensional stability, and (6) acceptable cost as compared to the cost of the reflector structure. The first phase of this development is based on evaluating several candidate deployable boom concepts with respect to preliminary requirements. Two concepts currently under evaluation include the Astromast (Fig. 21) developed by Astro Research Corporation, Santa Barbara, California, and the Tri-Extender (Fig. 22) developed by LMSC. Other concepts and their derivatives will be evaluated before the final selection is made at the beginning of 1981, when the design requirements have been finalized. Development of the selected concept will include the design, fabrication, and testing of a "proof-of-concept" hardware model. This engineering model could be a complete scale model, or a full-size section of the deployable boom that would be used in conjunction with the 55-meter diameter reflector structure. Whatever hardware approach is selected to demonstrate technology readiness, the size and complexity will have to accommodate direct scaling to large size designs.

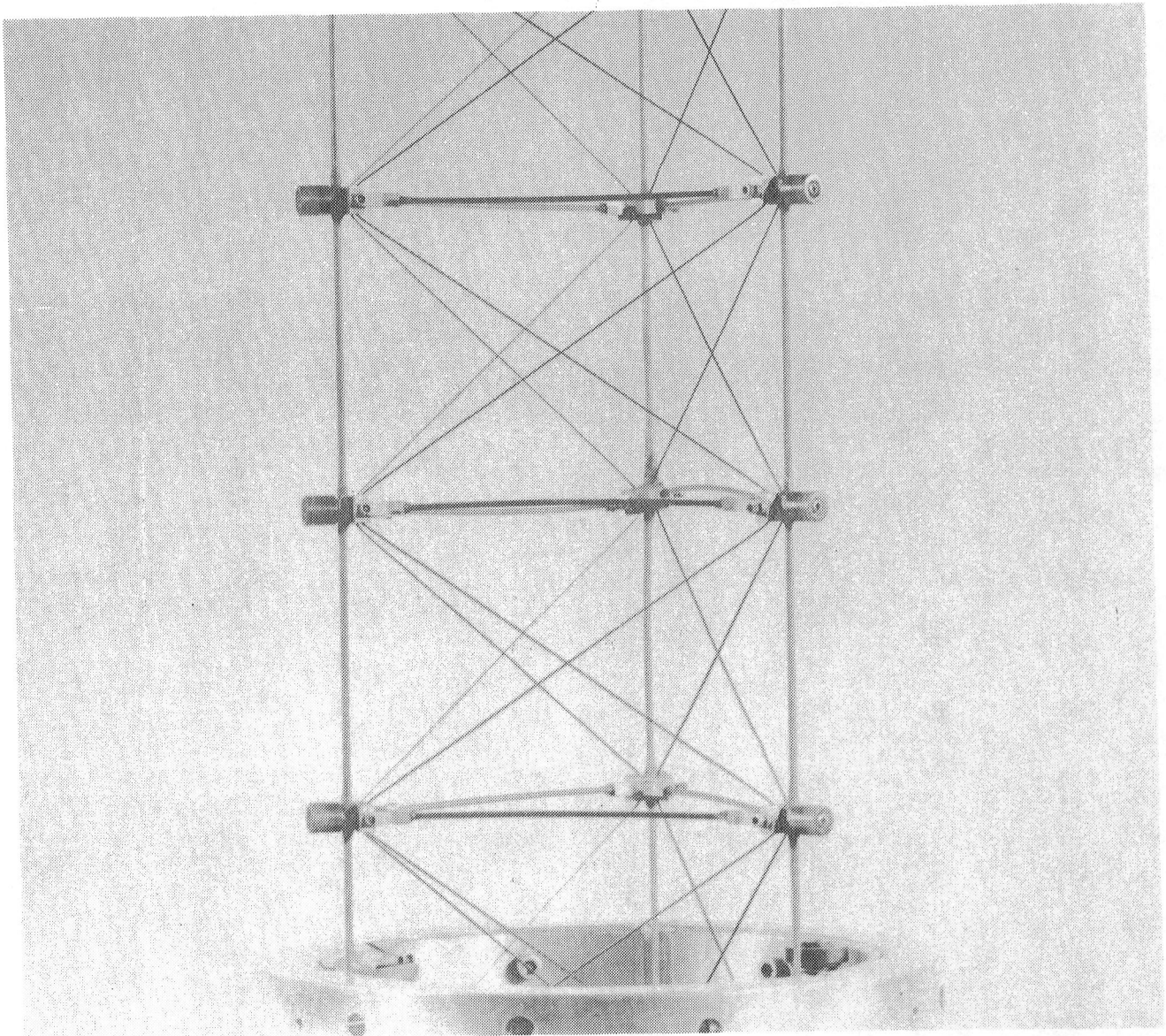

Fig. 21. Astromast concept.

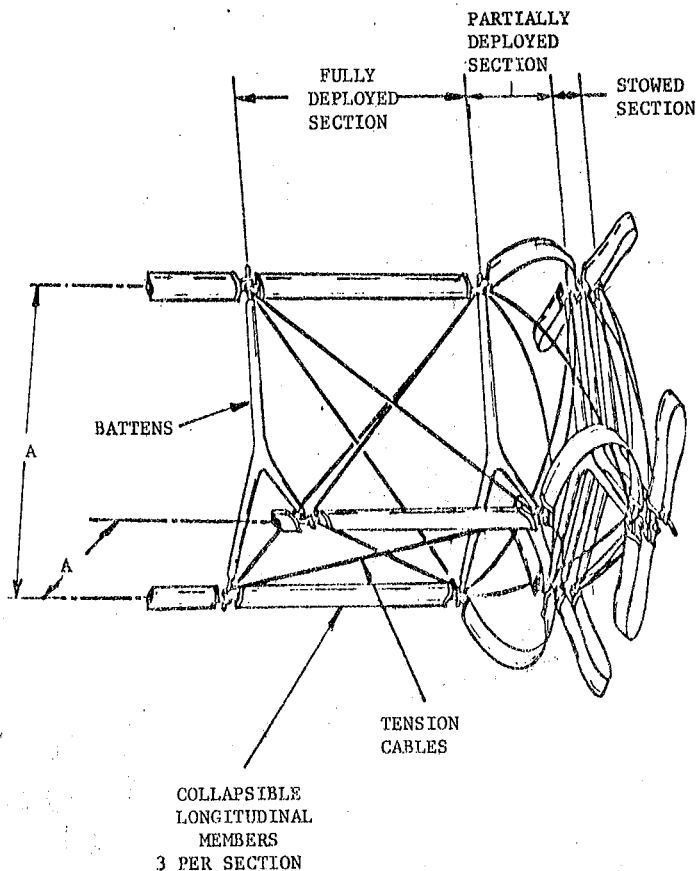

Fig. 22. Tri-extender concept.

Reflector surface adjustment. Since one of the major sources of reflector surface errors result from an orbit thermal distortion, an on-orbit surface adjustment to correct this particular distortion could result in an increased RF efficiency and a higher operational frequency for the same basic structure. Specific surface adjustment techniques considered for such an adjustment include: (1) rib-root translation and rotation, (2) rib-mounted heaters, (3) rib-mounted heat pipes, and (4) rib internal pneumatic bladders. The simplicity of the hub design at the transition of the rib allows the use of simple jack-screw type actuators in conjunction with the rib-root hinge. Such an arrangement of actuators can produce translation of the rib (radially and parallel) to the antenna axis, and rotation about an axis tangential to the hub at its intersection with the rib. Because of this straightforward approach, the rib-root adjustment technique has been selected for evaluation during 1980. The potential value of this particular adjustment technique will be evaluated analytically and then verified with proof of concept hardware. First, the on-orbit thermal distortions will be analytically characterized for the classes of applications intended for offset reflectors. Then, rib adjustments will be performed analytically on finite element structural models to determine the optimum correction commensurate with the subject adjustment technique. Scale model antenna hardware will then be built with the surface biased to represent on-orbit thermal distortion. Finally, the ribs of the hardware model will be adjusted as suggested by the analysis. The measured surface improvement, as a consequence of the adjustment, will then be projected analytically for the full-size reflector structures. These analytical estimates of improved surface precision (along with cost estimates for implementing such an adjustment technique) will be the basis for a decision concerning further development of this technique or alternate techniques. This decision is scheduled for the first part of 1981.

Analytical performance prediction. The potential value of specific large offset reflector antennas for specific applications can only be determined analytically at this time. In fact, this will be the case until on-orbit verification of hardware designs can be made. These analytical estimates of antenna performance are essentially estimates of reflector surface precision and the alignment of the feed support structure with respect to the reflector in the intended service environment. These analyses must account for the reflector surface parabolic approximation loss, thermal distortion, and structural/control interaction. There are several steps associated with the analytical characterization of large antennas. The first step for evaluation of an antenna concept with respect to a specific application of an antenna concept with respect to a specific mission would probably involve a quick, low cost characterization of the structural configuration. This analysis would contain enough detail to understand the potential bounds of performance for the mechanical configuration for comparison with antenna requirements. This would be the basis for determining whether a more refined analysis is required. The next step in the analysis would be based on a detailed antenna design and would be significantly more complex and expensive to accomplish. Both of these levels of analysis are under development for support of the wrap-rib antenna concept. The "quick look" type analysis capability is being developed by Jet Propulsion Laboratory (JPL) to: (1) understand the fundamental wrap-rib antenna concept, (2) accomplish independent assessment of potential antenna performance, and (3) determine the applicability of this concept for a number of different applications. The more detailed analysis capability already exists at LMSC, and is being utilized to: (1) support the detailed design of the 55-meter engineering model, (2) determine potential levels of performance for specific applications, and (3) develop estimates of cost for the different sizes and configurations of antenna.

Ground test of 55-meter model. The ground test of the 55-meter diameter proof-of-concept model will represent the largest ground-based demonstration for this concept. The ground test program will include: (1) deployment and refurling of single rib structures, (2) deployment and repeated refurling of the 4-rib partial antenna, (3) deployment and refurling of the feed support structure, (4) measurement of rib stiffness and surface contour for comparison with analytical predictions, and (5) possibly, adjustment of individual ribs to improve surface quality. The reflector ribs will be supported during deployment and furling operations (Fig. 23). The rib support system consists of four sets of balance beam/carriage assemblies for each rib. These assemblies ride on fixed rails that are located radially with respect to the antenna. The deployment displacements of the ribs will be tracked by the carriage assemblies in the radial direction and by the balance beams in the vertical and lateral directions. This passive support system progressively offloads the weight of the ribs and mesh as they unfold from the central hub. To maintain the rib positions approximately colinear with the overhead support rails, the hub will be mounted on a platform that rotates during deployment. The three degrees of freedom accommodated to the ribs during deployment by the support system results in a controlled deployment sequence where the unfolding mesh is not affected by the rib support system. Since the effect of gravity loading on the mesh will tend to force the mesh against the deployment control devices, the ground demonstration of mesh management with respect to identifying snagging problems is considered conservative.

Preliminary design of 100-meter diameter antenna. Since the wrap-rib antenna technology development is intended for structures up to 100 meters in diameter, the results of the new 55-meter data base will be used to accomplish a preliminary point design of a 100-meter diameter antenna. The detailed design of the 55-meter diameter hardware will be based on a scaled down version of a 100-meter antenna. This was to accommodate scaling of the test results from 55 to 100 meters. However, since significant modifications to the design of the 55-meter hardware could result as an outgrowth of its development and testing, the 100-meter size antenna design

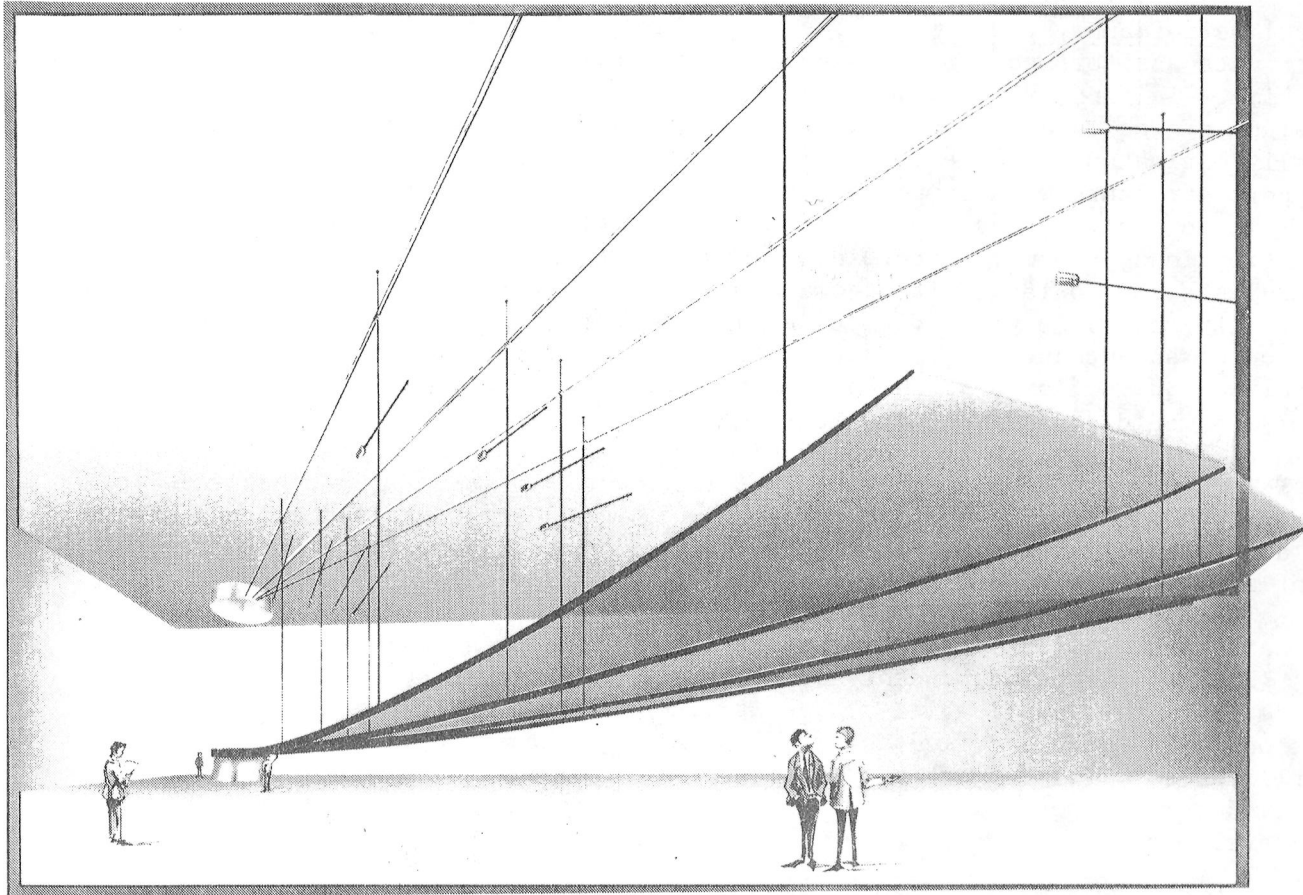

Fig. 23. Ground test of offset wrap-rib 55-meter antenna.

will reflect the same changes. This preliminary design will contain sufficient detail to accommodate estimates of functional performance and hardware costs. The new data base (along with current LMSC hardware experience) can also be used to generate estimates of performance and cost for smaller size deployable antennas (i.e., 5 to 50 meters in diameter). The basic offset structural design for deployable antennas up to 150 meters in size is directly applicable for axisymmetric reflectors with F/D ratios of 1.0 or larger. The difference in curvature between the offset and axisymmetric is sufficiently small to allow the same set of rib tooling and hub structure to be used for either configuration.

Results of Antenna Technology Development Program

Results of the offset wrap-rib deployable antenna technology development will include, but should not be limited to: (1) high confidence structural designs for antennas up to 100 meters in diameter, (2) high confidence estimates of functional performance and fabrication cost for a wide range of antenna sizes (up to 300 meters in diameter), (3) risk assessment for fabricating the large size antennas, and (4) 55-meter diameter flight quality hardware that can be cost effectively completed to accommodate a flight experiment and/or application.

Large antenna designs. The preliminary designs for the large size antennas will have benefited from addressing and solving the same basic types of problems on the 55-meter hardware that would be encountered on the larger size structures. These issues will include: (1) materials selection, (2) design and manufacturing of tooling and fixturing, (3) parts fabrication, (4) machining, (5) assembly, (6) ground-handling, and (7) testing. This development approach is expected to

eliminate the potential for encountering technical "show stoppers" during design, fabrication, assembly, and testing of large size wrap-rib antennas intended for space flight application.

Performance and cost estimates. The estimates of functional performance and fabrication cost for the offset and axisymmetric wrap-rib antennas are based on analytical models. The confidence associated with the estimates is proportional to the validation of the models with respect to real hardware. The new data base hardware will be used to augment the existing data base for smaller size structures. The analytical performance models will be partially verified by component and assembly evaluation for sizes up to 55 meters. These evaluations will include structural stiffness, assembly surface contour, and thermal characteristics. The analytical cost models will be validated for hardware up to 55 meters in diameter. Projections of performance and cost for larger structures will be based on conservative scaling factors (i.e., 1.8 for scaling from 55 to 100 meters for near-term developments, and 2.7 for scaling from 55 to 150 meters for far-term programs).

Risk assessment. A risk assessment will be performed as a function of antenna size and frequency. The assessment will address antenna hardware design and fabrication, assembly, ground-handling and evaluation, performance prediction, cost estimates, and ground-handling facilities requirements and limitations.

55-meter flight quality hardware. The development of the 55-meter proof-of-concept hardware is intended to exercise and evaluate the exact process and procedures that would be used for developing large size flight hardware antenna systems. For this reason, the quality of the design, tooling, hardware, assembly, and handling fixtures for the 55-meter diameter partial antenna are expected to be commensurate with engineering model quality hardware. Therefore, this ground-test model could be upgraded to a full flight quality reflector by: (1) fabricating a sufficient number of additional ribs to meet the RF frequency requirements using the new data base tooling, processes, and procedures; (2) modifying the hub structure to accommodate a larger number of ribs; (3) fabricating and installing additional mesh gores using new data base fixtures, processes, and procedures; and (4) building a complete feed support structure that is based on completing the partial data base proof-of-concept model, or a scaled up version of a proof-of-concept model.

MAYPOLE (HOOP/COLUMN) ANTENNA PROGRAM

Introduction

As described earlier, the hoop/column concept has the potential capability of providing several different surface contour designs from the same basic configuration. The hoop/column antenna was developed to a feasibility level during the AAFE Program (ref 12), but now more detailed design and analytical activities (coupled with hardware verification tests) are underway through the LSST Program at the Harris Corporation.

Since the applicability of the hoop/column concept with respect to the antenna focus mission is of utmost concern, the results of the mission scenario activity strongly influenced the selection of the baseline configuration--the point design for the LSST Program. Basically, the communication mission scenario was adjudged to contain a significant number of technology drivers; so, the baseline configuration for the hoop/column was selected on that basis. Therefore, it was imperative that the hoop/column antenna be configured so that the requirements associated with the communication mission (beams using offset feed reflectors) would be addressed. Hence, a significant difference between the LSST effort and the previous AAFE study is in the antenna feed configuration that is required for the hoop/column reflector.

During the AAFE study, axisymmetric feed configurations ($F/D < 1$) were used; but emphasis must now be placed on asymmetric feed configurations. Initially, once this new feed configuration was required, it appeared that the continued development of the hoop/column antenna could be challenged. But, now a multiple aperture concept ($F/D > 1$) using offset feed configurations has been introduced using the hoop/column design. The multiple aperture approach has led to a quad aperture concept which will be developed through the LSST Program. The quad aperture concept is generated by defining a separate reflector surface in each quadrant of the basic antenna surface. This concept appears to be very promising as several offset fed apertures could be provided within the same antenna structure.

Configuration Definition

Since the purpose of the hoop/column development program is to develop the concept to a detailed design level, it was first necessary to establish a set of design specifications. These specifications were developed after the mission scenarios were reviewed and an assessment of the technology drivers was made. The plan and task flow for developing the point design specifications are outlined in Fig. 24. Through this plan, the point design for the hoop/column and the related manufacturing and test plans were developed. As indicated in Fig. 24, the point design

REVIEW MISSION SCENARIOS:

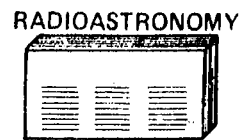
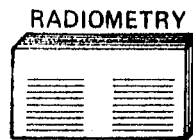

DEVELOP CONFIGURATIONS:

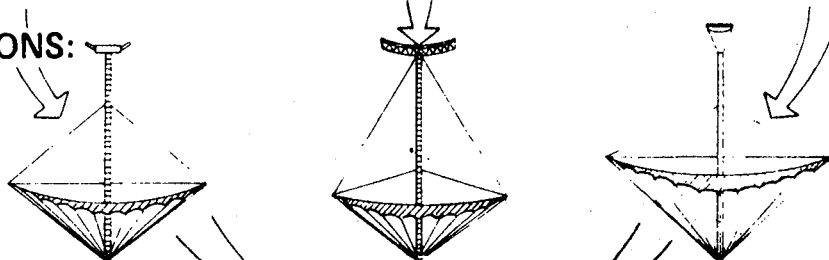

IDENTIFY TECHNOLOGY DRIVERS:

POINT DESIGN SPECIFICATION

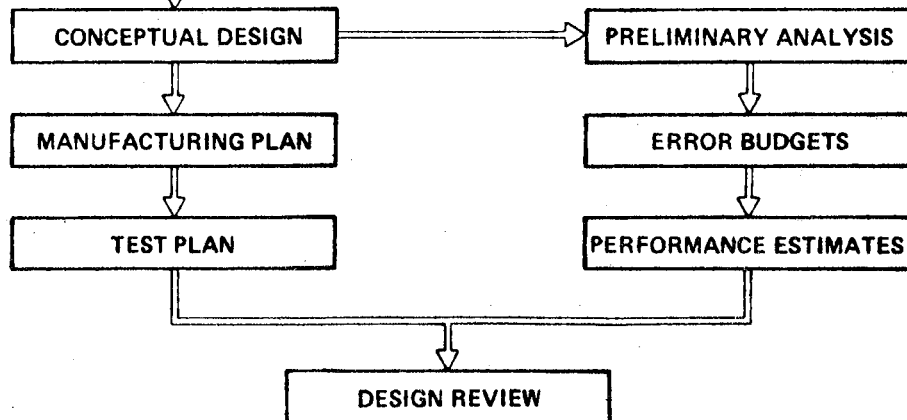
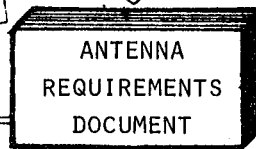

Fig. 24. Flow in developing point design specifications.

specifications are contained in an antenna requirements document, and these specifications are expected to guide and constrain the technology development throughout the LSST Program.

Point design. As noted earlier in the discussion of the mission scenarios, the multiple beam communication and radiometry missions contain more stringent technology drivers. These drivers strongly influenced the baseline configuration for the hoop/column concept development. The selection of appropriate designs to fulfill these mission requirements places great importance on configuration dependent parameters. In that regard, symmetrically illuminated reflectors are not amenable for high performance multiple beam applications because of aperture blockage effects. Therefore, asymmetrical or offset fed reflectors are desired since the appropriate secondary beam pattern can be produced while minimizing aperture blockage effects. A significant problem, however, in using an offset fed reflector system is in the size of the feed arrays that will be required to produce the high crossover levels desired for a multiple beam system. The space limitations encountered in using the multiple beam feed arrays are expected to dictate the use of several offset reflectors for the advanced communications mission.

The hoop/column offset design is achieved by generating separate reflector surfaces throughout the symmetrical configuration. As an example of this approach, separate reflector surfaces have been generated in each quadrant of the reflector, thereby creating a quad aperture configuration. The focal point for each quadrant reflector is totally offset so that the feed system does not block the aperture. With this multiple aperture approach, the area now available for the feed array elements has been increased significantly. To meet the focus mission requirements, 55 beams could illuminate each quad reflector to produce a total of 220 beams from the entire system. Each feed array will be attached to the central column and beam interleaving is adjusted by translating the feed array in two dimensions. This approach should effectively scan the beams and fix the beam-to-beam crossover points at the desired levels. The total structural size for the offset geometry is the same for the symmetrical configuration so that F/D for the offset reflector is essentially doubled.

The use of the quad aperture hoop/column antenna configuration would also require innovative mesh designs for the reflective surfaces. For example, multiple meshes will be required throughout the quad reflector for the following reasons: first, an open mesh (transparent at the operating wavelength) will be used on the main portion of the reflector but outside the respective illuminated regions. This would allow side lobe energy to leak through the outside region of the reflector. Secondly, the reflector mesh system could accommodate dual frequency operation (C-band and Ku-band) by using frequency selective surface (FSS) techniques. The FSS material in each quad aperture would allow for the wavelength differences (2.5) and produce equivalent beamwidths at each frequency. The use of FSS with the hoop/column design is discussed in ref. 20.

Therefore, it can be seen that the quad aperture hoop/column concept is more complex than the symmetrical configuration and, indeed, more challenging from an antenna design standpoint. Also, the technology that is developed through the LSST Program should be more beneficial. The critical parameters selected for the 100-meter point design quad aperture configuration are listed below:

- o 100-meter diameter parent reflector,
- o Quad offset apertures--40.6 meters in diameter each,
- o F/D = 1.53,
- o Focal length (single offset)--62.12 meters,
- o Frequency from point design--2.0 GHz,
- o Half power beam width--0.256°,

- o 220 beams, 55 beams/aperture,
- o Surface accuracy-- $\lambda/20$,
- o Beam to beam isolation--30 db,
- o Gain--55.4 db, and
- o Point accuracy-- 0.03° .

The hoop/column point deployed design configuration is shown in Figs. 25 and 26. The stowed geometry configuration is shown in Fig. 27.

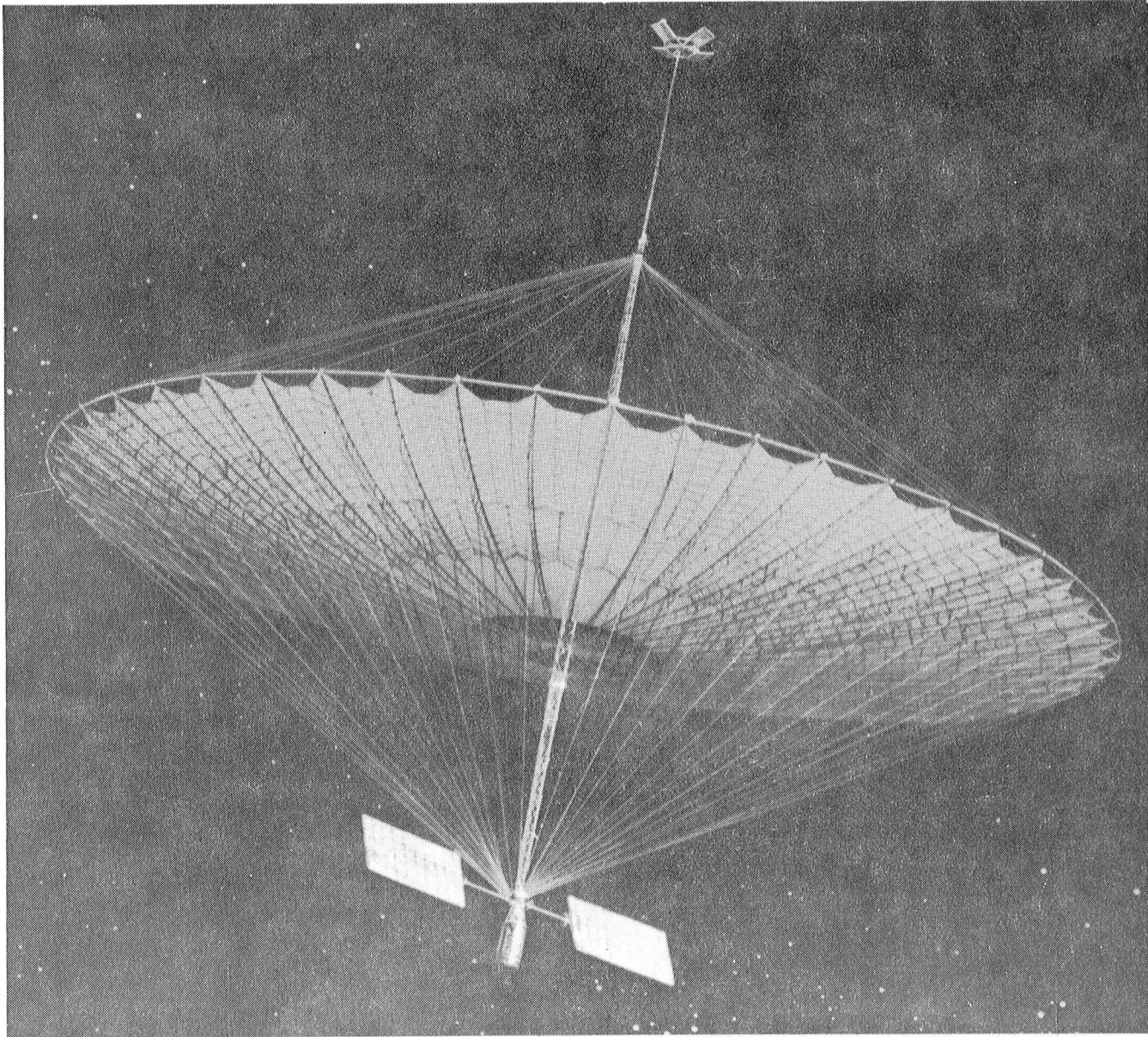

Fig. 25. Maypole (hoop/column) 100-meter diameter antenna.

Concept description. The hoop/column antenna has four major structural elements: the telescoping mast, an articulated hoop, reflective mesh, and a cable network. These are described below.

1. Telescoping mast: The mast consists of a central hub and 14 telescoping sections which are deployed by means of a cable drive system. The hub is the

**100M POINT DESIGN
ASSEMBLY DEPLOYED**

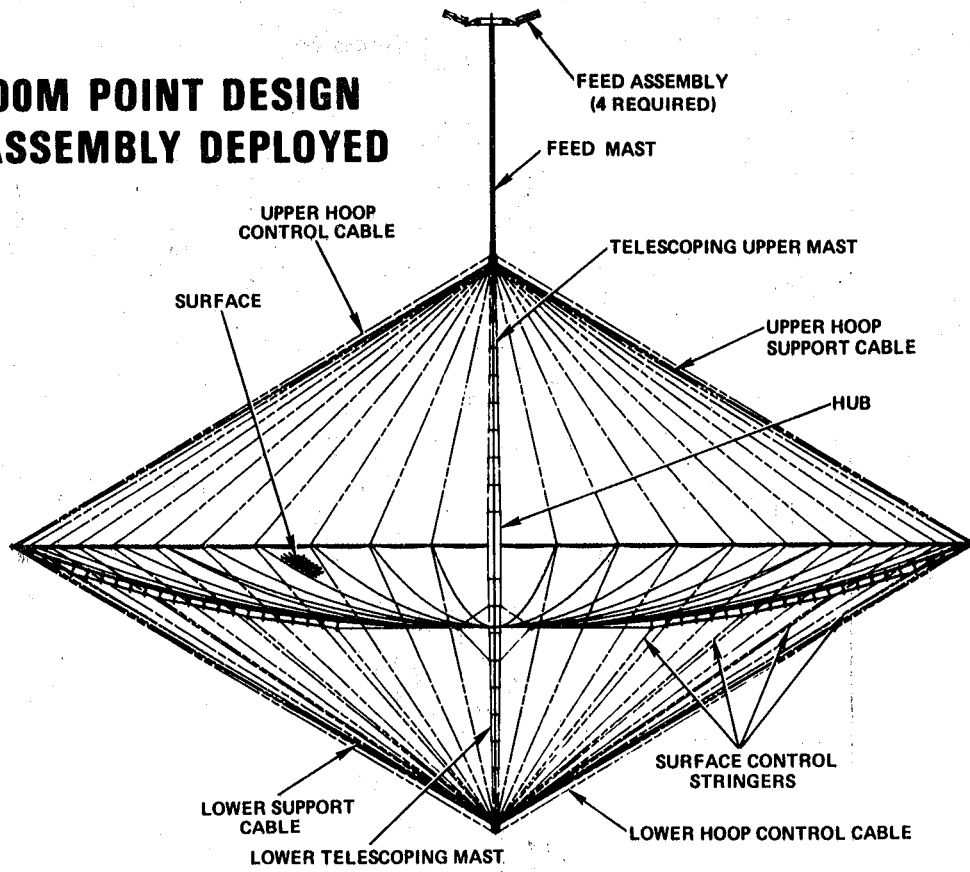

Fig. 26. Maypole (hoop/column) 100-meter point design.

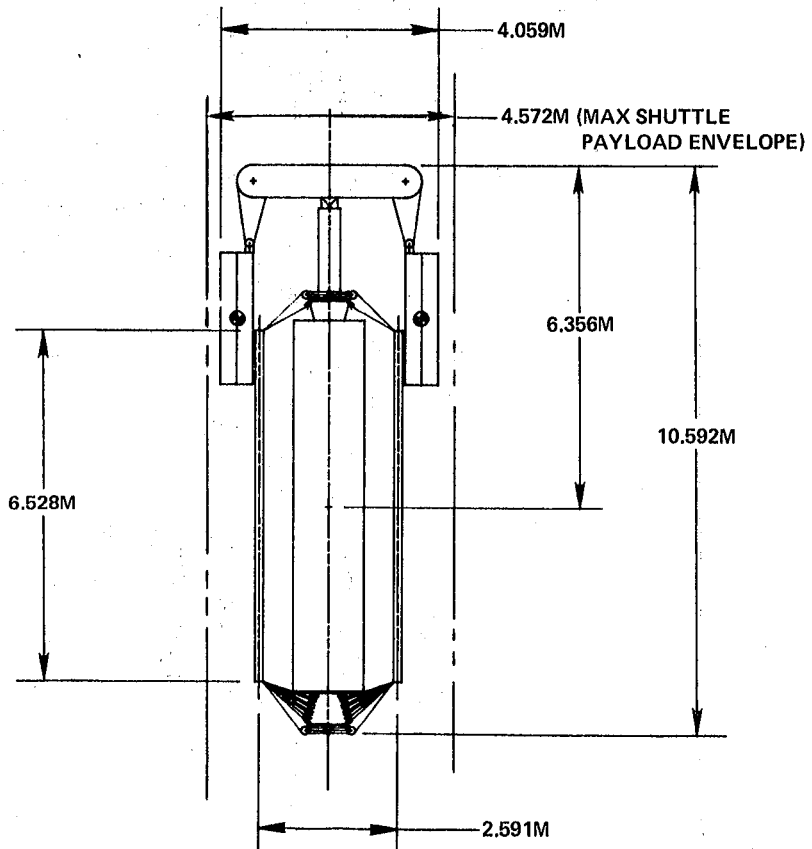

Fig. 27. Maypole (hoop/column) 100-meter point design stowed characteristics.

largest section of the mast and houses all of the telescoping sections of the stowed column. It also provides the attached joints for all control cables and the antenna surface. The mast will be made from graphite fiber reinforced plastic (GFRP) to minimize the thermal expansion of the column.

2. Articulated hoop: The hoop is divided into 48 rigid segments (40 segments used in AAFE design) which articulate at hinges joining adjacent segments. These segments consist of tubular GFRP members with bonded titanium hinge fittings at each end. Motor drive units located at four places (90° apart) supply the total energy required to deploy the hoop. The hinges are a unique design which provide symmetric motion of the hoop members around each connecting hinge joint. Total hoop synchronization is provided by the addition of strips linking one hinge joint to each adjacent hinge joint. Fig. 28 shows a schematic representation of the hinge and associated members. The hoop provides a rigid, accurately located structure for attachment of an antenna surface.

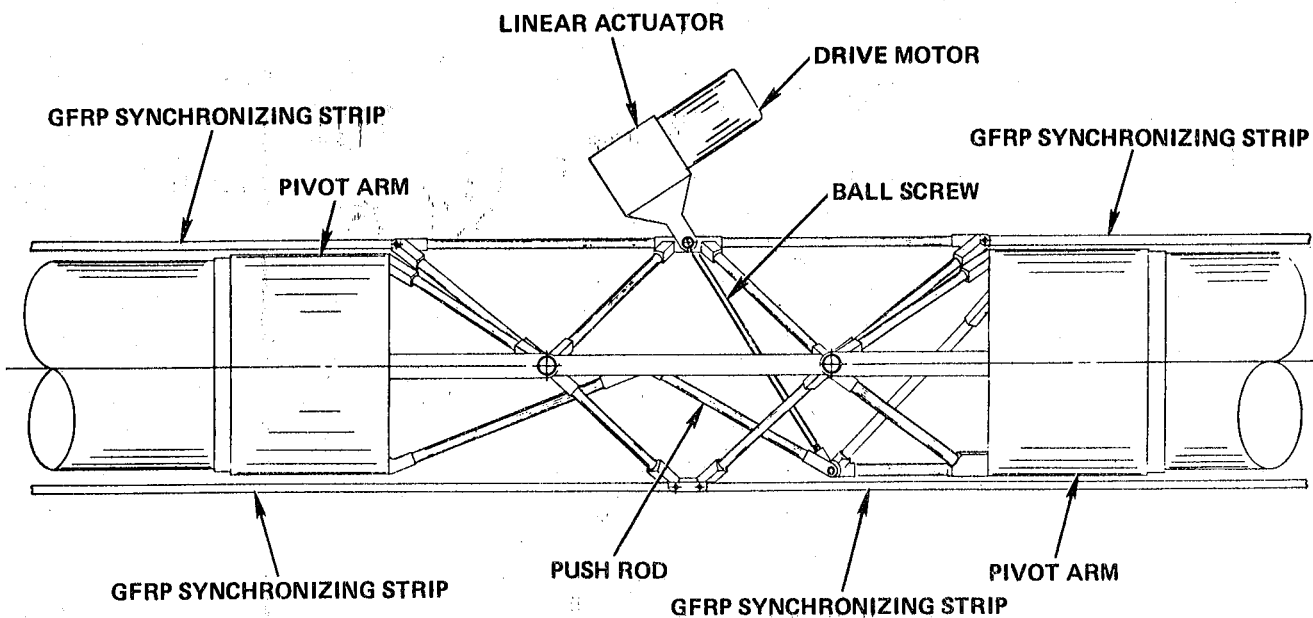
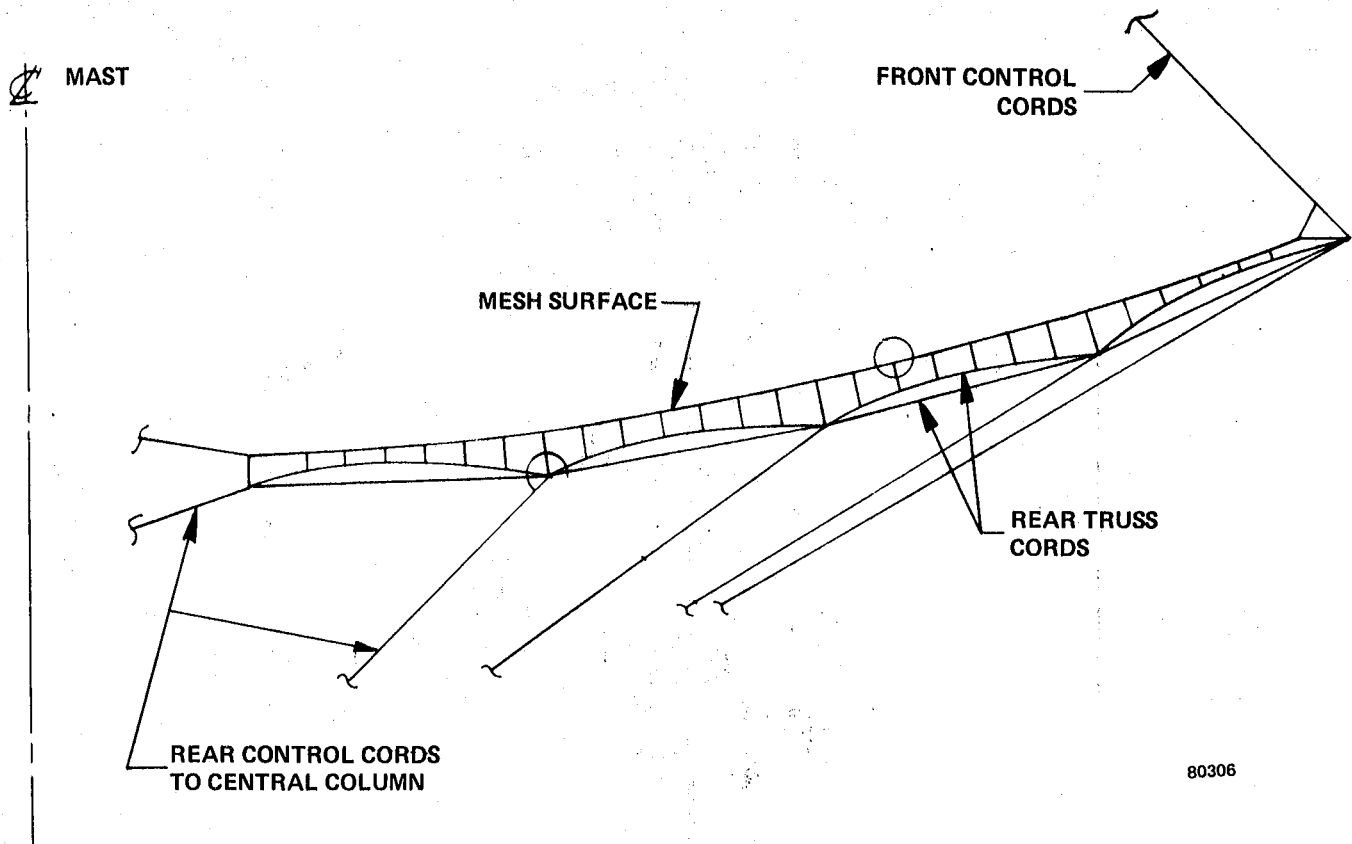

Fig. 28. Maypole (hoop/column) hinge/hoop segment.

3. Reflective mesh: The reflective mesh is formed by knitting gold-plated molybdenum wire together. The mesh grid can be varied to meet a given RF reflectivity requirement. The mesh is suspended from the hoop at the hoop hinges with cords made of quartz or graphite fibers. The cords, interlaced in the mesh, run in a radial direction to attachment points on the mast. The mesh is pulled into the desired shape with control cords that are attached to the reverse side of the mesh through a cable network that consists of a periodic catenary (Fig. 29). There are also circumferential tie cords that attach at the end of the ties in the radial direction. The control cords attach to the suspension cord at four discrete points, and the shape of the mesh surface is controlled by varying the individual tie lengths. The quad aperture surface will be generated by varying the lengths of the ties between the surface and the surface control stringers. Since the focal point for each quad aperture is offset from the focal point for the entire reflector, the surface contours will be adjusted accordingly.



80306

Fig. 29. Maypole (hoop/column) surface shaping technique.

4. Control cable network: The hoop support cables will be made of a braided, graphite fiber flat tape. This material and configuration was selected because of the low coefficient of thermal expansion, high modulus, and ease of winding on spool.

The deployment sequence for the hoop/column antenna is shown in Fig. 30. The deployment sequence is initiated when the mast is extended into the deployed position. This is accomplished by a cable that is attached to the innermost section of the mast and then interwoven over pulleys at each end of the remaining mast sections. The mast sections are deployed in unison so that at any time during the deployment, each section has traveled an amount proportional to its length. The sections are locked into position by a reversible latching mechanism (except for the last mast section). Upon completion of the hoop deployment (Fig. 31), the last mast section extends, tensioning the control cables and preloading the entire structure. The hoop position, relative to the mast, is maintained with four upper control cables and four lower control cables attached to the mast. The restow cycle is the exact reverse of this deployment sequence.

Concept Development Program

Basically, the LSST Program is planning to complete the hoop/column design and conduct design verification tests to prove that the multiple aperture concept can provide efficient multiple beam performance characteristics. After completing the numerous LSST activities, it will then be possible to evaluate this concept through meaningful trade-off studies. Recognizing the fact that smaller deployable designs do not adequately identify problems associated with large antennas, the technology efforts are focused on the following issues:

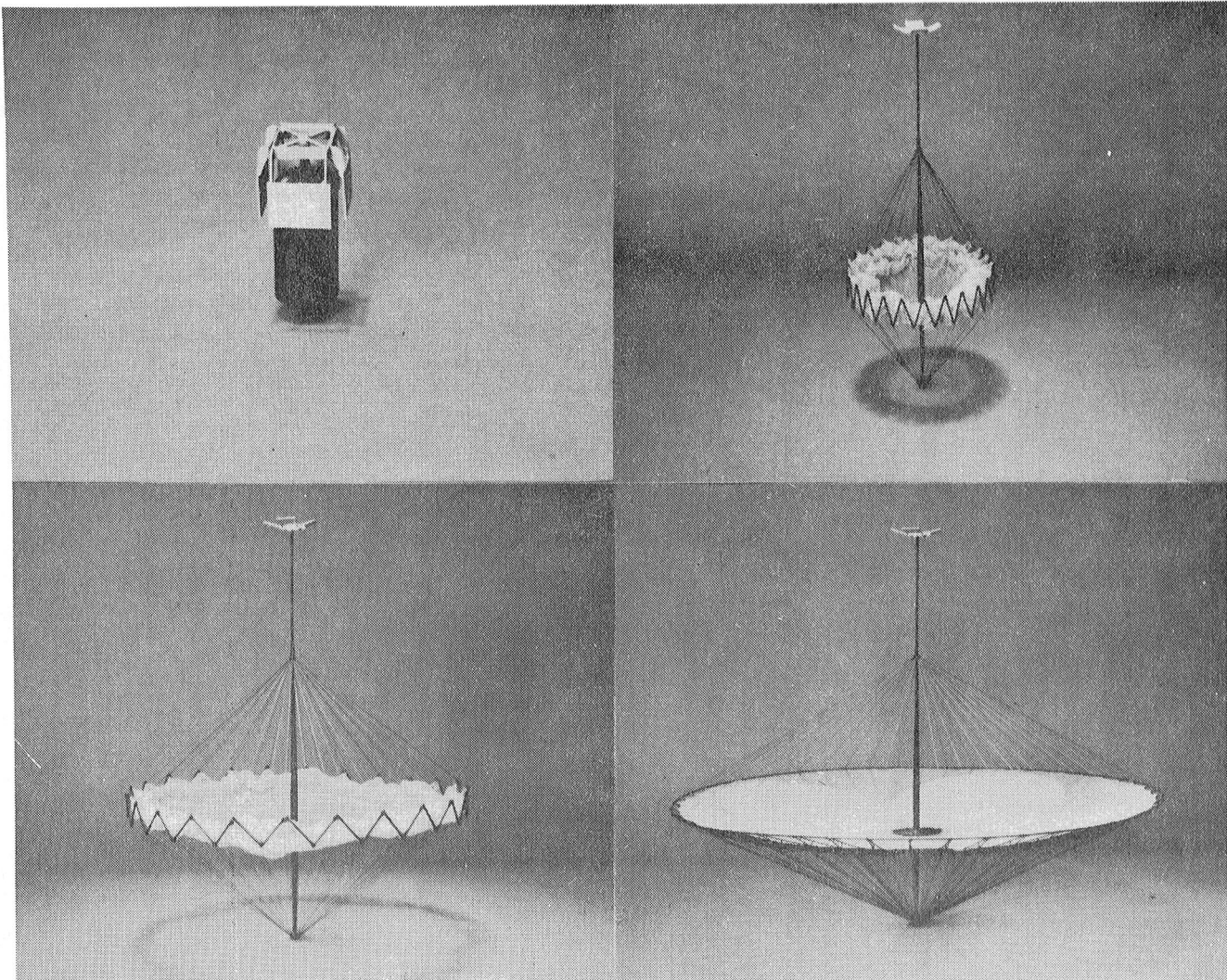

Fig. 30. Maypole (hoop/column) 100-meter point design deployment sequence.

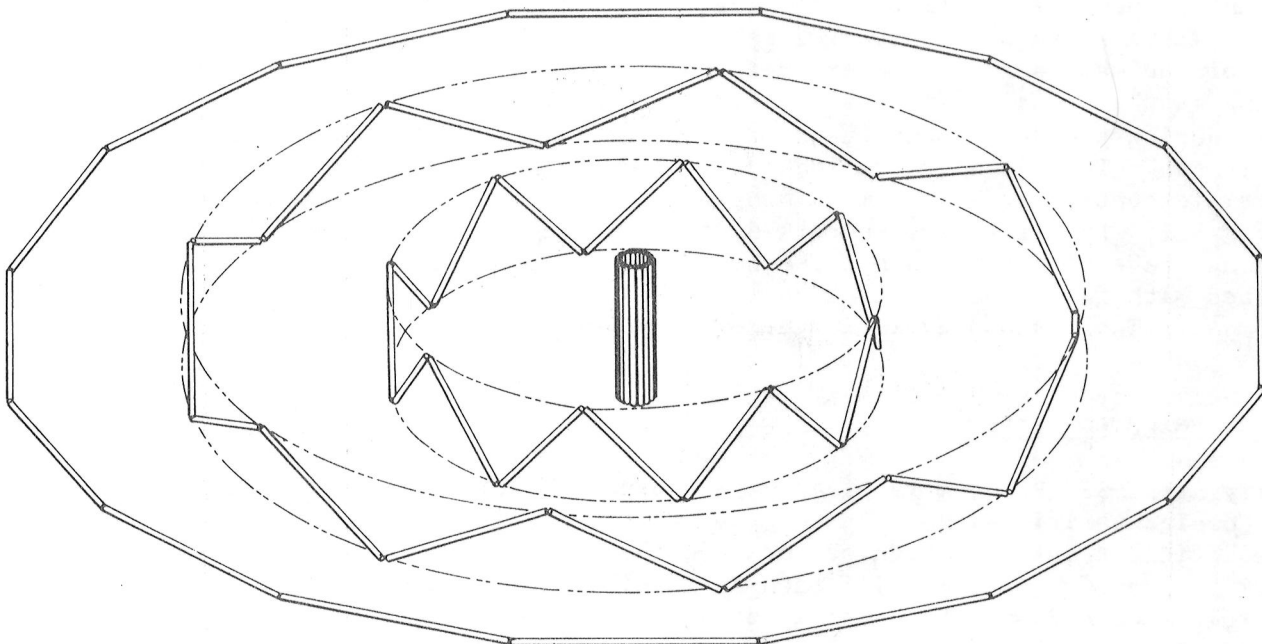

Fig. 31. Maypole (hoop/column) single stage hoop deployment sequence.

- o Development and demonstration of hoop/column reflector technology to satisfy focus mission requirements;
- o Verification of the analytical technique for predicting reflector performance;
- o Development and verification of scaling relationships that allow extrapolation of performance to a wide range of antenna sizes;
- o Development and verification of design analytical and control methods for reflector surface adjustment techniques;
- o Development and demonstration of measurement systems to allow orbital evaluation of the reflector contour, including integrated demonstration of these measurement systems with the reflector;
- o A verified parametric cost model for each large antenna system; and
- o Verified techniques and procedures for the manufacture, assembly, and testing of large antenna systems.

The concept development plan was completed after the configuration for the hoop/column point design was selected. Basically, with this plan, a technology base will be developed in the discipline of mechanical design, thermal, structural, electromagnetic analysis, manufacturing, and testing. Also in this plan, emphasis will be placed on analysis and verification of analysis methods so that further performance extrapolation can be made. The increased reliance on analysis for performance predictions of large space structures is dictated by the fact that ground testing of the full-scale systems will not be feasible. An overview of the concept development plan is presented in Fig. 32. The concept development plan is divided into four basic areas: concept design analysis, materials development, economic assessments, and experimental model development. Each of these task areas will be discussed.

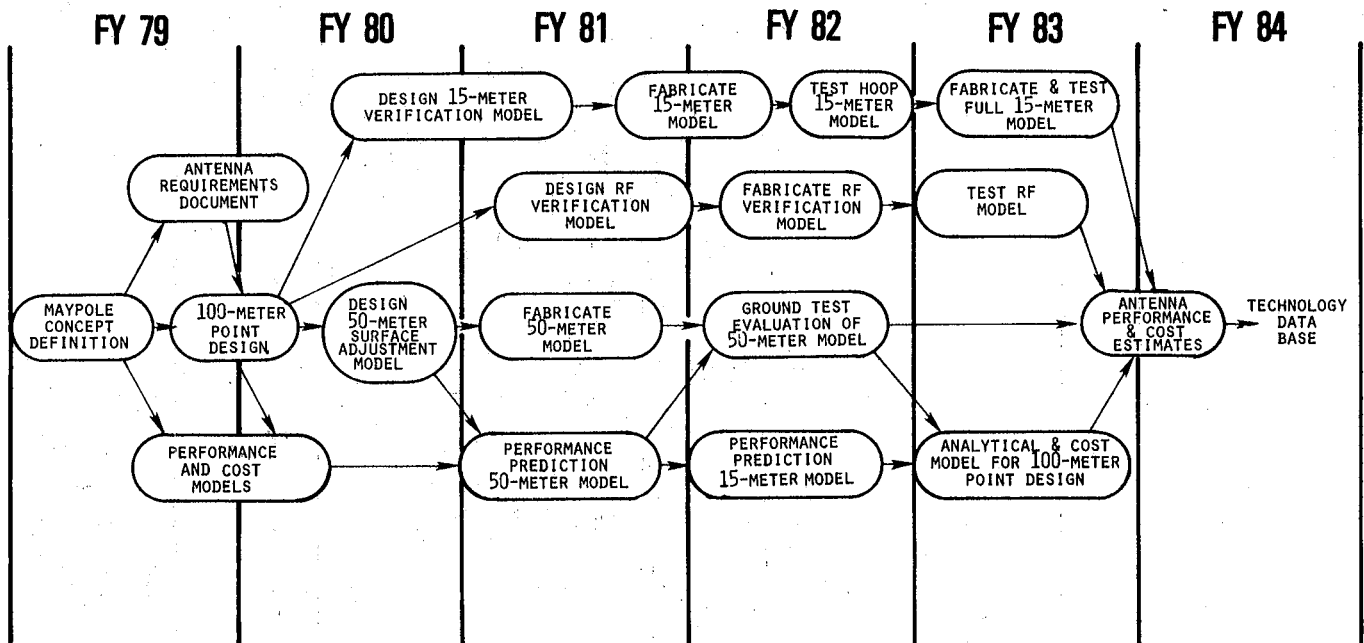

Fig. 32. LSST maypole (hoop/column) technology development plan.

Conceptual design and analysis. This task will establish detailed system level performance specifications and requirements for the hoop/column antenna. Then the specific subsystem (and components) suitable for deploying, pointing, and controlling the antenna shall be designed and analyzed. Analysis methods using existing and extended computerized modeling techniques will be developed to predict the performance capability for the hoop/column antenna in the 15- to 300-meter diameter range. The analysis areas shall include thermal, structural stress, deformation and dynamics, structural materials, and electromagnetic analysis. The major analyses used to analytically characterize the antenna are as follows: the reflector mesh surface will be analytically characterized to determine the loads and resulting deflections under on-orbit equilibrium conditions. The Nonlinear Structural Analysis Program (NLSA) developed by the Harris Corporation will be used to analyze these nonlinear structures including nonlinear gravity effects on the reflector surface. Thermal distortions of the reflector surfaces will be characterized by first determining the on-orbit heating rates with the Antenna Thermal Analysis Program (ATAP), developed by Harris, which utilizes the NLSA antenna description. The resulting heat rates are then used by the Systems Improved Numerical Differencing Analysis (SINDA) to determine the temperature distributions. These temperature distributions are then used by the NASA Structural Analysis Program (NASTRAN) or NLSA to complete the thermoelastic analysis of the antenna reflecting surfaces.

Since the ultimate radio frequency performance of the large deployable antenna is of utmost concern, the LSST Program through the Langley Research Center shall establish and verify techniques for predicting the electromagnetic performances of the large space antennas. Statistical and deterministic modeling techniques shall be developed that will include the effects of surface roughness, distortion, and segmentation. Basically, the electromagnetic analysis activity (as described in ref. 3) consists of the following two task areas.

First, present techniques in applying aperture integration for large reflectors shall be extended to include planar and curved segmented reflectors. In this activity, the far-field radiation pattern will be computed by numerically performing a double integration over the aperture plane. The relatively slow lateral variation of fields in the aperture plane (compared with that of surface currents on the reflector) allows a more economical computation than does the integration of surface current.

Second, to determine the effects of large scale surface errors on electromagnetic performance, aperture tolerances corresponding to quadratic, quasi random, and Gaussian distributed phase errors shall be determined. The results to date indicate that the general effect of deterministic phase errors will raise side lobe levels and reduce beam efficiency. Generally, the theory developed by Ruze (ref. 22) is used in predicting the performance of reflector antennas. But, in Ruze's work, the phase errors (produced by surface distortion) are chosen from a Gaussian population which is statistically uniform over the reflector surface. Hence, the beam efficiency is a function of the RMS surface error with normalized correlation lengths as a parameter. It has been shown (ref. 3) that smaller correlation lengths cause more stringent requirements on surface error for high beam efficiency.

For more slowly varying surfaces (large correlation lengths), the surface error can be relaxed and still allow relatively high beam efficiencies.

These analyses methods shall be verified through the construction and testing of experimental antenna models. In the case of the hoop/column antenna, an RF verification model shall demonstrate performance for multiple beam applications. All of these results shall be used to verify the electromagnetic analysis methods in that the overall accuracy of the performance prediction for 100-meter antennas will be enhanced.

A major goal of the hoop/column technology development program is to validate these analytical tools. Another aim is to extend their capabilities where necessary for application to large space deployable antennas. Proving these tools will be accomplished by measuring their prediction performance against experimental data gathered from testing the subscale engineering model hardware on the 100-m point design.

A preliminary analytical performance prediction for the 100-m point design has been conducted. The results indicate that the RMS for the reflector surface is 0.3 in (0.76 cm). Most of this error results from manufacturing uncertainties which will be minimized by making surface accuracy measurements on the engineering models.

An antenna requirements document (ARD) has been developed and will be updated throughout the life of the technology development program. The document will contain current information on environmental profiles, system integration requirements, geometrical constraints, mass properties, surface control and measurement requirements, and ground-handling requirements. The final copy of the ARD will contain sufficient informational detail so that the document can be used as a technical guide in planning a flight experiment.

The conceptual design effort will culminate in a detailed hoop/column point design. The point design will be updated during the course of the program as new information becomes available from the fabrication and testing of engineering models of the concept. Included in the final documentation of the point design will be a set of drawings of the antenna components.

Final documentation will include a manufacturing flow plan for the hoop/column antenna. Experience gained in the procurement, fabrication, and assembly of the engineering models and components will form the basis for the flow plan. Finally, a test plan philosophy for large space antennas will be developed by establishing both the advantages and shortcomings of ground-based testing for this concept.

Materials development. This task will characterize unique materials necessary for the hoop/column concept development based on applicable antenna requirements and specifications. Specific emphasis is to be placed on developing cable technology by defining the structural, thermal, and environmental requirements for the hoop/column materials.

To accomplish these goals, a data base on the mechanical properties for various cable materials and constructions will be developed by conducting data research and testing components such as: cable-end fittings, hinge fittings for the graphite/epoxy hoop segments, and full-length cable assemblies. The synthetic materials used in the cable construction will be subject to ultraviolet radiation.

Economic assessment. This task will develop and validate a system economic model suitable for quantitatively evaluating program cost relationships and performing cost projections. This will be accomplished by continually updating the

computerized cost data base by factoring in information gained from procuring, fabricating, assembling, and testing engineering models. This economic model will be utilized to project the program costs associated with the 100-meter point design as well as sizes up to 300 meters in diameter.

Experimental models. Efforts within this task area will: (1) provide hoop/column scaled hardware models which satisfy the focus mission configuration requirements, and (2) identify critical hoop/column components. This will be accomplished by building full-scale components and subscale engineering verification models where necessary. The verification models will:

- o Establish fabrication and assembly procedures for large size, cable supported, mesh reflectors;
- o Demonstrate that large scale mesh reflectors can be built to a prescribed curvature within acceptable tolerances;
- o Establish the surface shape to the desired contour and establish if in-flight adjustments of the surface are necessary;
- o Determine the compatibility of an engineering in-flight surface accuracy measurement system (SAMS) with the hoop/column design;
- o Compare experimental results of surface setting and adjusting on the model with analytical predictions of surface accuracy and surface improvements to cable adjustment;
- o Establish ground handling procedures for folding the hoop, mesh, cables, and mast into the stowed position;
- o Demonstrate the deployment kinematics of the hoop, mesh, cables, and mast during the deployment sequence;
- o Measure the surface accuracy of a mesh surface after deployment; and
- o Establish the effects of cable blockage on the RF performance of the antenna.

There are three major engineering models planned for the hoop/column technology development program: (1) a 50-meter surface adjustment model, (2) a 15-meter deployable antenna model, and (3) an RF verification model. These will now be discussed:

1. 50-meter surface adjustment model: This model will be a 4-gore section of a 50-m diameter parabolic antenna. There are several objectives for this model:

- o It provides a realistic evaluation of the proposed manufacturing techniques of large antenna mesh surfaces.
- o Test data will be gathered on the accuracy in setting a large mesh surface to the desired shape.
- o The accuracy of the analytical predictions concerning surface tie points and loads, and the resulting surface shape will be evaluated.
- o Determine the ability of an on-orbit surface contour adjustment. Adjustment of the surface is important in order to counter a distorted antenna after deployment or degradation of the surface over a period of time.
- o Test engineering models of flight surface accuracy measurement systems.

Figure 33 shows a schematic of the test setup for the surface adjustment model. The four gores will be suspended from a rigid tower and hoop section. The radial boundary of the outboard gores will be rigidly attached to a support structure. The two inboard gores will serve as the test bed for surface adjustment with the outboard gores serving as isolators from the rigid radial boundary constraints. The mesh surface contour can be adjusted by varying the lengths of the shaping cords on the back side of the reflector. Surface contours will be measured with

a computerized theodolite system. These measurements will be compared with analytical predictions of the surface contour for this specific model.

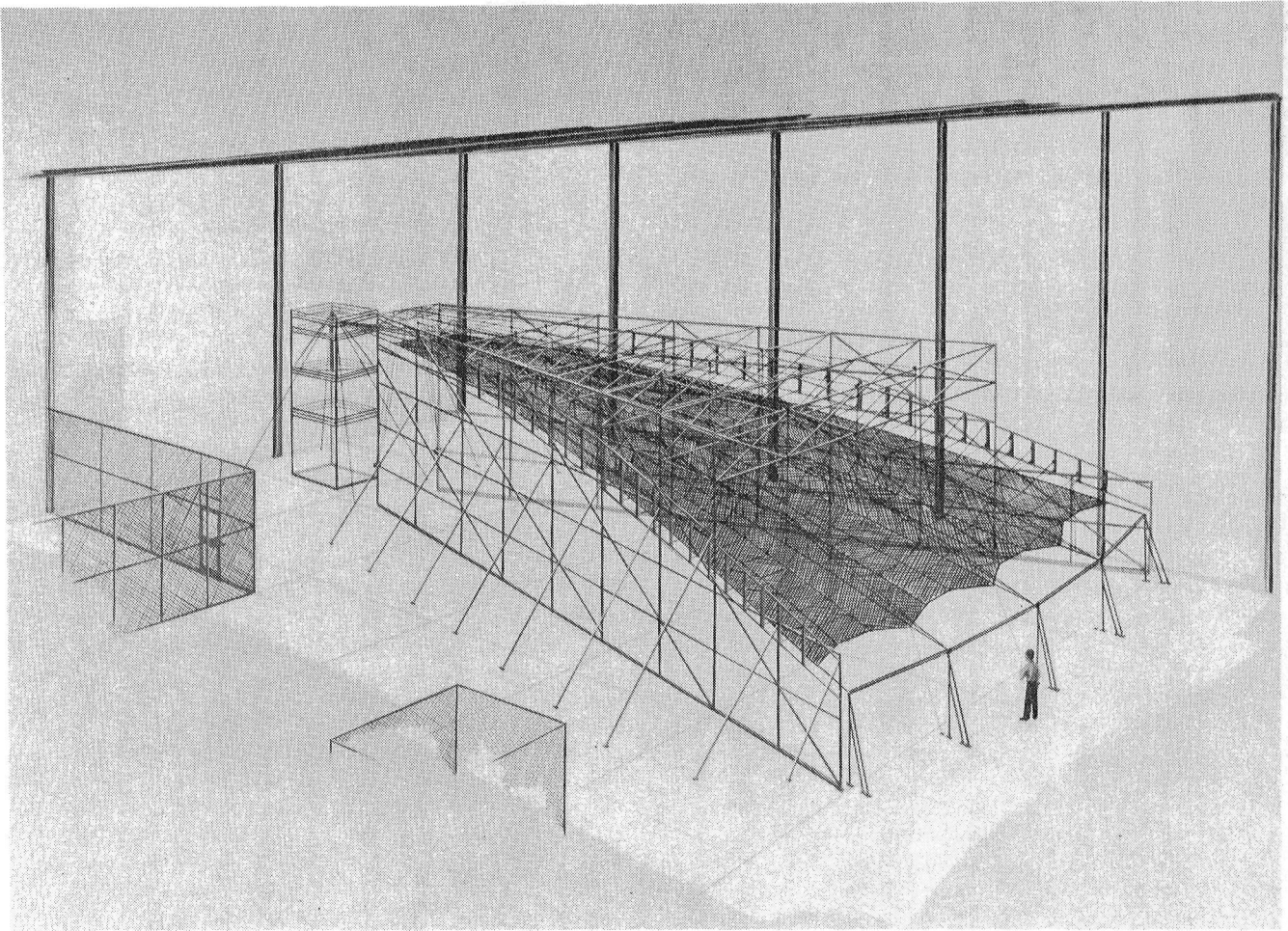

Fig. 33. Maypole (hoop/column) 50-meter surface adjustment model.

2. 15-meter kinematics model: A second major piece of test hardware to be built will be a 15-m diameter complete hoop/column scaled engineering deployable model of the point design (Fig. 34). The objectives of this model are:

- o Investigate the kinematics of the deployable mast and hoop;
- o Determine the best technique for controlling the mesh material for stowage and deployment;
- o Measure surface accuracy after deployment;
- o Determine the feasibility of restowing a deployable antenna;
- o Establish the reliability, repeatability, and manufacturing techniques by conducting full mechanical systems tests; and
- o Verify scaling laws to aid in moving from one size antenna to another.

The 50-m surface adjustment model will be used in conjunction with the 15-m kinematics model in verifying the scaling laws.

3. RF verification model: As experimental antenna models will be used to verify the electromagnetic analysis methods described earlier, an RF verification model will be used to evaluate the performance of the hoop/column point design. The RF test model will closely resemble the point design, but will consist of only one aperture of the quad aperture point design. A structural support frame will

be used for mounting the mesh surface and the feed assembly. The mesh surface will be set to allow radio frequency measurements at the selected frequency. All aspects of hoop/column point design that could affect the radio frequency performance will be modeled, and the offset parabolic reflector surface will be shaped as in the point design. The hoop control cords that will be used in the RF test model will represent typical flight materials. This will allow accurate testing to determine the effect of cable blockage on multiple beam performance.

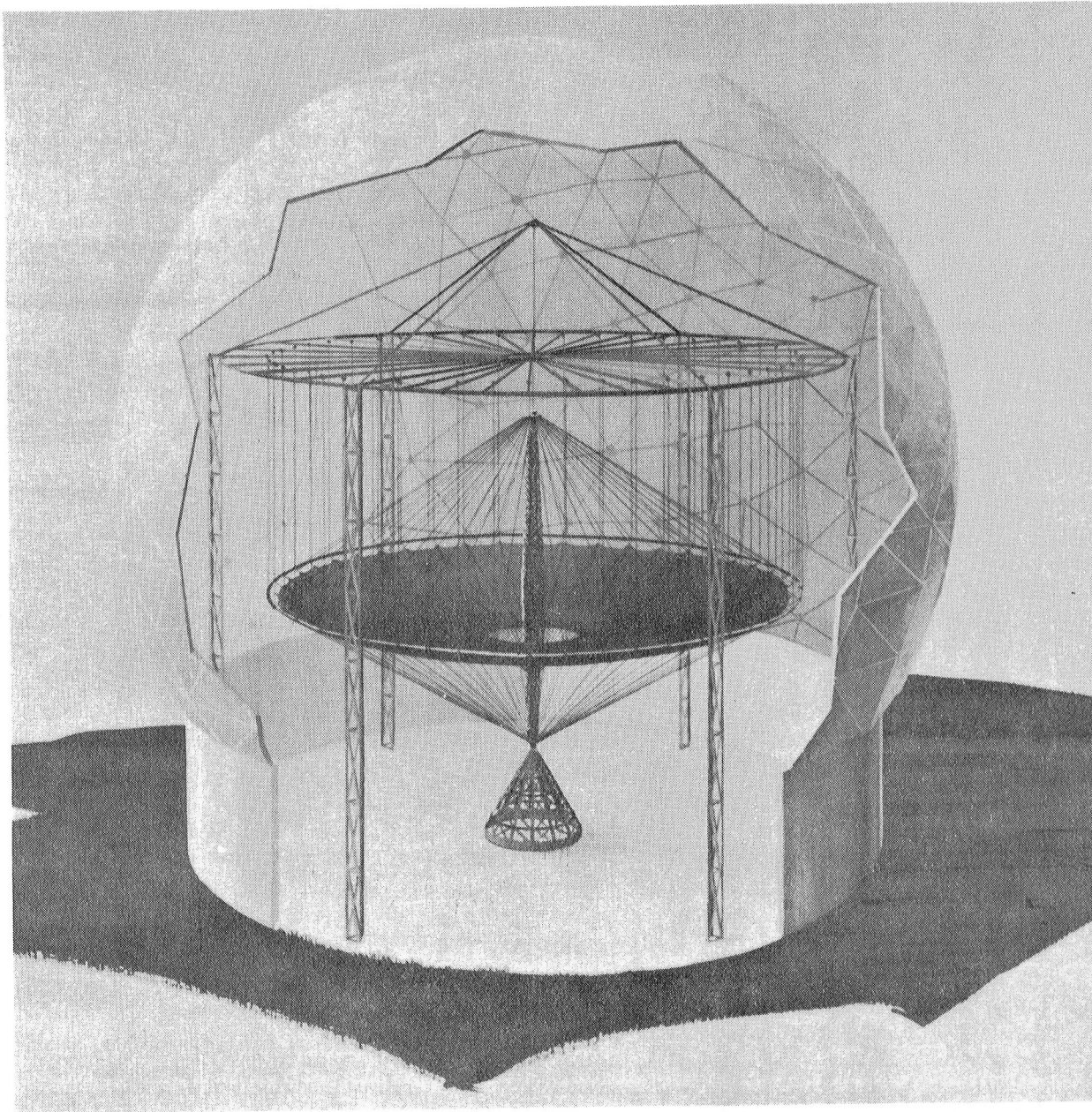

Fig. 34. Maypole (hoop/column) 15-meter verification model.

The co-polarized and cross-polarized patterns will be measured, and the gain for each beam shall be determined. Each gain measurement will be compared with predicted gains. Predicted gains will have been obtained prior to the gain measurements by calculating the aperture efficiencies from the feed primary pattern and by characterizing the RF performance of the reflector surface based on measured surface roughness and beam loss of offset feeds.

The measurement test results using the RF verification model will be useful in the substantiation of the analysis as well as various mechanical parameters associated with the hoop/column antenna (e.g., surface accuracy, cable effects, etc.).

In addition to the above models, critical components will be designed and tested. A full-scale hoop hinge joint (100-m point design) is being designed. Three joints will be fabricated and tested for synchronization and reliability. Also, a multisection deployable mast model will be designed, fabricated, and tested to verify the design.

CONCLUDING REMARKS

The development of the hoop/column antenna concept is ongoing, and plans include continuation of the program through fiscal year (FY) 1984. The results of the hoop/column development program will provide analytical models that have been partially validated from hardware models. This will provide the capability to conduct a risk assessment of the concept, to predict the performance (RF and structural) of the concept for any given application, to project realistic antenna costs, and to define a flight experiment based on known antenna capabilities.

SUMMARY

Evaluation of the current technological capability for deployable antennas with respect to current and projected user requirements indicates that promising designs must be developed if we are to meet the technological challenges of the future. Achieving an acceptable system performance will depend on a complete system definition involving the application of exotic materials, improved manufacturing processes, extensive ground-based test programs, development of analytical performance prediction capability, and the control of structural/thermal/control interactions for the life of the space missions. To exploit the best feature of each concept, these technological improvements in each area must be addressed and demonstrated.

The LSST Program is sponsoring the technology development of two promising concepts described herein. The subject technology is expected to produce significant results that will benefit both near- and far-term mission requirements. The basic technology development sequence will consist of conceptual development, breadboard hardware testing, functional tests, and predictive analysis for performance projection. Expected results will include:

- o Development and verification of offset wrap-rib and maypole (hoop/column) antenna concepts for structures up to 100 meters in diameter;
- o Development and verification of predictive analysis methods for the deployment mesh antennas under development;
- o Development of surface adjustment capability for subject antennas;
- o Test and evaluation of breadboard models, scaled models, and components for concept verification;
- o Development of electromagnetic analysis methods for large space antennas;
- o Development of cost and performance models for subject concepts; and
- o Preliminary point design for 100-meter diameter antenna for subject concepts.

Space-based testing is expected to be required to complete the verification and validation of the scaling laws and predictive analysis methods developed during the Program.

ACKNOWLEDGMENTS

The planning and implementation of the technology programs described in this report required generous contributions of many individuals and organizations. The authors, therefore, acknowledge with much appreciation the following: Mr. Dewey M. Smith, Mr. George C. Olsen, and Mr. Fred L. Moore of the Langley Research Center; Mr. Ralph Chen, and Dr. Michael El-Raheb of the Jet Propulsion Laboratory; Mr. Art A. Woods, and Mr. W. D. Wade of the Lockheed Missiles and Space Company; and Mr. Don C. Montgomery, and Dr. W. Tankersley of the Harris Corporation.

REFERENCES

1. Powell, R. V.; and Hibbs, A. R.: An Entree for Large Space Antennas. *Astronaut. & Aeronaut.*, Dec. 1977, pp. 58-64.
2. Powell, R. V.: A Future for Large Space Antenna. 7th AIAA Communications Satellite System Conference, San Diego, CA, Apr. 23-27, 1978.
3. Large Space Systems Technology - 1979. NASA Conference Publication 2118, Nov. 1979.
4. Love, A.: Space Construction System Analysis. *Project Systems Review*. NAS9-15718, Dec. 1978.
5. Foldes, P.; and Dienemann, M. W.: Large Multibeam Space Antennas. AIAA/NASA Conference on Advanced Technology for Future Space Systems, Hampton, VA, May 8-10, 1979.
6. Lovelace, V. M.: A Microwave Radiometer Spacecraft. *American Astronautical Society*, vol. AAS78-151, Oct. 30, 1978.
7. Stacey, J.: A Large Aperture Space Antenna - Earth Looking Observations from Low Earth Orbit. JPL Publication 710-3, March 29, 1977.
8. Powell, R. V.: Large Space Antennas - Workshop on Space Radio Astronomy. JPL Publication 715-48, May 15, 1980.
9. Freeland, R. E.: Industry Capability for Large Space Antenna Structures. JPL Publication 710-12, May 25, 1978.
10. Freeland, R. E.; and Campbell, T. G.: Deployable Antenna Technology Development for the Large Space Systems Technology Program. AIAA/NASA Conference on Advanced Technology for Future Space Systems, Hampton, VA, May 8-10, 1979.
11. Russell, R. A.; Campbell, T. G.; and Freeland, R. E.: NASA Technology for Large Space Antennas. 49th Structures and Materials Panel Meeting for AGARD, Cologne, West Germany, Oct. 7-12, 1979.
12. AAFE Large Deployable Antenna Development Program. Executive Summary, NASA CR-3894, Sept. 1977.
13. Woods, A. A.; and Wade, W. D.: An Approach Toward the Design of Large Diameter Offset Fed Antennas. AIAA/NASA Conference on Advanced Technology for Future Space Systems, Hampton, VA, May 8-10, 1979.
14. Campbell, G. K. C.; and Damonte, J. B.: Large Furlable Antenna Study. LMSC/D384797, Jan. 20, 1975.
15. Woods, A. A.; and Chadwick, G. C.: Final Report for Study of Wrap-Rib Antenna Design. LMSC/D714613, Dec. 12, 1979.
16. Woods, A. A.; and Krueel, M.: Consideration of the Use of Graphite-Reinforced Plastics for Space Erectable Antennas. 7th AIAA Communications Satellite Systems Conference, San Diego, CA, Apr. 23-27, 1978.
17. Wade, W. D.; and Ellison, A. M.: The Application of Metal-Matrix Composites to Spaceborne Parabolic Antennas. SAMPE National Symposium, San Francisco, CA, May 1979.

18. Armstrong, H. H.: Satellite Applications of Metal-Matrix Composites. SAMPE National Symposium, San Francisco, CA, May 1979.
19. Woods, A. A.; and Wade, E. D.: On the Design of Self-Deployable, Extremely Large Parabolic Antennas and Arrays. IEEE 1977 Mechanical Engineering Radar Symposium, Nov. 1977.
20. Sikes, L. D.; and Campbell, T. G.: The Quad Aperture Maypole (Hoop/Column) Antenna for Advanced Communications Missions in the 1990's. IEEE/APS Symposium, Toronto, Canada, June 1980.
21. Ruze, J.: Lateral-Feed Displacement in a Paraboloid. Transactions on Antennas and Propagation, Sept. 1961, pp. 660-665.

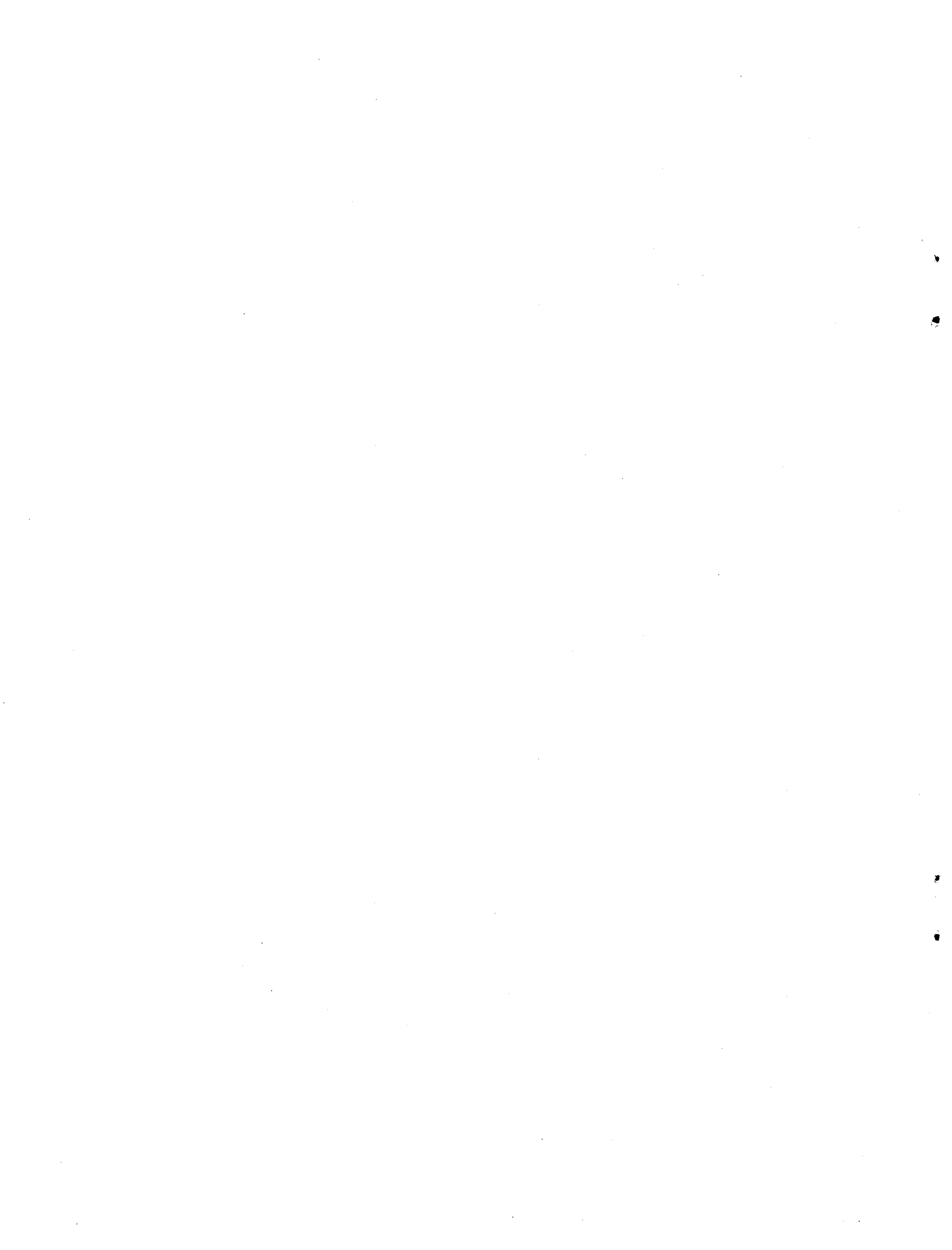

1. Report No. NASA TM-81902		2. Government Accession No.		3. Recipient's Catalog No.	
4. Title and Subtitle A Technology Development Program for Large Space Antennas				5. Report Date September 1980	
				6. Performing Organization Code	
7. Author(s) R. A. Russell, T. G. Campbell, and R. E. Freeland*				8. Performing Organization Report No.	
9. Performing Organization Name and Address Langley Research Center Hampton, VA 23665				10. Work Unit No. 506-62-43-05	
				11. Contract or Grant No.	
12. Sponsoring Agency Name and Address National Aeronautics and Space Administration Washington, DC 20546				13. Type of Report and Period Covered Technical Memorandum	
				14. Sponsoring Agency Code	
15. Supplementary Notes *Jet Propulsion Laboratory, Pasadena, CA 91103 This paper was presented at the Thirty-First International Astronautical Congress of the International Astronautical Federation, September 21-28, 1980, Tokyo, Japan (Paper No. IAF-80 A 33).					
16. Abstract Recent studies sponsored by both the National Aeronautics and Space Administration (NASA) and United States (U.S.) industry indicate the need for technology to accommodate potential applications for large space-based antenna systems. These potential space systems require apertures up to 100 meters (m) in diameter and larger for radio frequency (RF) operation up to Ku-band for communications, Earth observations, and radio astronomy applications. NASA's Large Space Systems Technology (LSST) Program was created to develop technology that will lead to the realization of large space systems which are cost-effective and Space Transportation System (STS) compatible. For large space-based antenna systems, the LSST Program has selected deployable antennas for development. The maturity of this class of antenna, demonstrated by the success of smaller size apertures, provides a potential capability for satisfying a significant number of near-term space-based applications. Two specific antenna concepts selected for development are the offset wrap-rib and the maypole (hoop/column) configurations. This paper is focused on a detailed review of the current and planned technology program for the two mesh deployable, antenna concepts selected for development. This paper further discusses the NASA mission model that generically categorizes the classes of user requirements, the methods used to determine critical technologies and requirements, and presents performance estimates for the mesh deployable antenna selected for development.					
17. Key Words (Suggested by Author(s)) Large space antennas; space missions, mesh deployable antennas; focus missions; maypole (hoop/column) antenna; offset wrap-rib antenna; point design			18. Distribution Statement Unclassified - Unlimited Subject Category 18		
19. Security Classif. (of this report) Unclassified		20. Security Classif. (of this page) Unclassified		21. No. of Pages 43	22. Price* A03

