

NASA Technical Paper 1743

NASA
TP
1743
c.1

LOAN COPY: RE
AFWL TECHNIC
KIRTLAND AFB

0067662



TECH LIBRARY KAFB, NM

Optimal Regulation in Systems With Stochastic Time Sampling

Raymond C. Montgomery and Peter S. Lee

NOVEMBER 1980

NASA



NASA Technical Paper 1743

Optimal Regulation in Systems With Stochastic Time Sampling

Raymond C. Montgomery and Peter S. Lee
Langley Research Center
Hampton, Virginia

NASA

National Aeronautics
and Space Administration

**Scientific and Technical
Information Branch**

1980

SUMMARY

An optimal control theory is presented that accounts for stochastic and variable time sampling in a distributed microprocessor-based flight control system. The theory is developed by using a linear process model for the airplane dynamics where the information distribution process is modeled as a variable time increment process for which, at the time that information is supplied to the control effectors, the control effectors know the time of the next information update only in a stochastic sense. A stochastic optimal control problem is formulated and solved for the control law that minimizes the expected value of a quadratic cost function. An example is presented where the theory is applied to the control system design of the longitudinal motions of the F-8 DFBW (digital fly-by-wire) airplane. Simulation results were generated by using a Monte Carlo simulation in which one of three possible sample times was selected with a Markov process for each sample time interval. For each sample, the control system did not know what the sample time was at the start of the sample time interval. Theoretical and simulation results indicate that, for the example problem, the optimal cost obtained by using a variable time increment Markov information update process in the control system is almost identical to that obtained with a known and uniform information update interval.

INTRODUCTION

The availability of microprocessors, assembled from a small set of large-scale integration (LSI) logic, has presented the control system designer with new opportunities for sophisticated control system design. Many designers of control system components have improved their products through the use of microprocessors. This fact is substantiated in reference 1, where a design of a microprocessor-controlled rate gyro is presented. The use of microprocessors in the rate gyro resulted in an improved performance and a substantial savings in hardware. The trend of device manufacturers to use microprocessors as integral parts of their equipment is expected to continue. The features of a microprocessor - flexibility, modularity, good hardware communications, and low cost - have made distributed control a suitable answer to many control problems.

The following sketch shows an example of a distributed flight control system with minimal module requirements from the airplane flight control point of view:

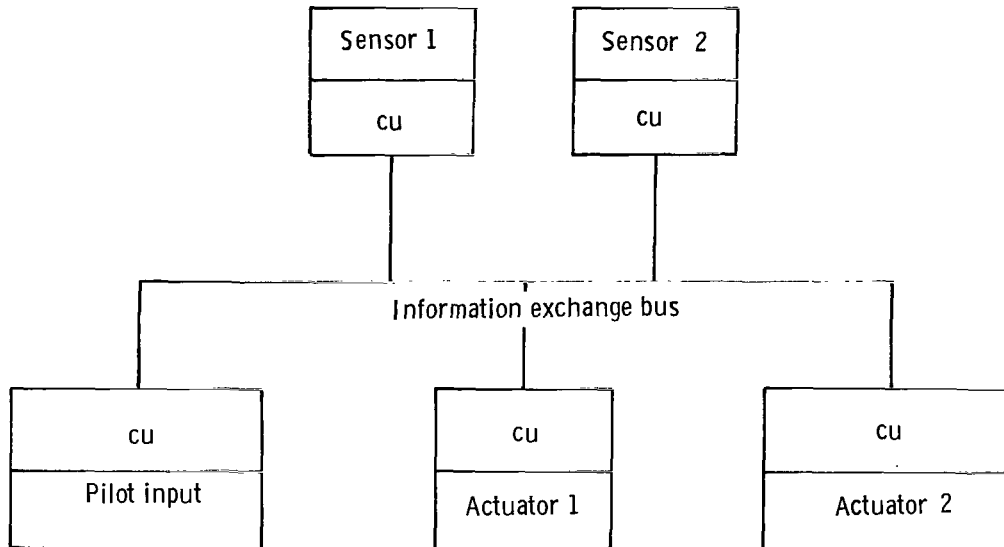

Note that a microcomputer control unit (cu) is associated with each physical device in the system and that each controller can communicate with the other physically distributed elements by using an information exchange bus. Operating systems for distributed flight control systems will necessarily be complex and will employ various techniques for reducing data flow in the information exchange buses and for ordering of tasks. The need for reducing the data flow is dictated by the finite bandwidth of the information exchange bus whereas the need for task ordering is dictated by the finite computational resources of the system and by reorganization requirements to accommodate component failures. This paper addresses one aspect of the data flow problem - specifically, the case where sensor components obtain an estimate of the state of the airplane and transmit the estimate to the airplane flight control effectors by using the information exchange bus. It is assumed that data compression techniques are used to reduce the bus traffic and that the state is updated to the control effectors only when required to maintain adequate performance of the system. Thus, there will be variable time intervals between information updates to the control effectors. Accounting for the variability in the information update time intervals is an important consideration in the design of the logic of the controllers for the flight control effectors. This paper presents a theory for accomplishing this based on a stochastic modeling of the information update process.

In spite of the fact that the optimal control theory of sampled data stochastic linear system has advanced rapidly since some of the early contributions (refs. 2 and 3), nearly all results have been obtained under the assumption of the existence of a centralized decision maker which takes all the measurements and generates all control inputs. For systems with multiple decision makers, a general computationally feasible theory does not exist at the present time. Information exchange is a critical issue in a distributed-control system where no controller, local or central, possesses a complete description of the system. The controllers, therefore, must exchange information among themselves in order to achieve satisfactory operation.

The type of information available to a controller for its decision making is called its information pattern (ref. 4). For a distributed processing system, information patterns differ considerably from those of a centralized control system in which the central controller is assumed to have complete and instantaneous information of the system. Because of its decentralized nature, a distributed control system may have a stochastic information pattern where the data are sampled at random times. Modern control theory has only a limited amount of available work on this practical aspect of control problems, the past emphasis being on single rate control and filter problems which are well developed (refs. 3 and 5). It has been assumed that the information pattern is deterministic and control systems with stochastic information patterns have received little attention. Accordingly, the primary emphasis of this report is the stochastic nature of the sampling process. In this research, a stochastic model of a sampling process is developed which accounts for (1) variable time intervals in sampling systems; (2) uncertainty of data arrival time in multiplexed communication systems; and (3) multirate sampling systems. The first suggestion of stochastic sampling is believed to be reference 6 where an optimal control policy was obtained for a system with a discrete Markov sampling process. However, the optimal solution was restricted to a process in which the time interval between each information update was known to the system at the initiation of the interval. In the present report, an optimal policy is obtained for virtually all Markov sampling processes. The restriction is further relaxed to include the situation where the control unit does not have to know the duration of the information update interval at its initiation. Instead, the control unit only has knowledge of the past history of the information update intervals. The assumption is more applicable to a distributed control system because its control units ordinarily will not know how long they will have to act with the same information.

As an example, the theory is applied to the control of the longitudinal motion of the F-8 DFBW (F-8 digital fly-by-wire) airplane. Both theoretical and simulation results indicate that, for the application example, the optimal cost obtained by using a variable time increment Markov information update process (where the controller knows only the past information update intervals and Markov transition mechanism) is almost identical to the cost obtained by using a known uniform update interval. This result is significant because in the stochastic sampling case the sampling process is known only in the stochastic sense; that is, at any instant the system controller does not know the time of the next sample, only its statistics. The expected performance of the system is, however, nearly the same as that of an optimally designed system that has uniform and known sampling.

SYMBOLS

- A $n \times n$ matrix used to represent airplane dynamics
- B $n \times m$ matrix used to represent influence of airplane controls on airplane dynamics
- E expectation operator

f arbitrary function
I identity matrix
J cost function
K gain matrix
k index indicating information update interval
M number of admissible information update intervals
m,n indices indicating information update intervals
N index indicating last interval of an N-stage process
 N_i number of occurrences of sample time s_i in simulation
P $n \times n$ matrix which is sensitivity of cost J to initial condition variations
p probability density function
Q $n \times n$ matrix weighting state in cost function J
q pitch rate
R $m \times m$ matrix weighting control in cost function
S $n \times n$ matrix weighting terminal value of state in cost function J
 s_i element in space of update intervals which is discrete, finite, and stationary
T transition matrix for stationary Markov process
 T_k element of T_k, t_1, \dots, t_k
t time
 t_k element of τ_k
u m -dimensional control column vector
v airspeed
v m -dimensional control column vector after transformation
W $n \times m$ matrix weighting x, u cross-product term in cost function J
x n -dimensional state vector

α	angle of attack
Γ	control input matrix in difference equation representation of airplane dynamics
γ, δ	dummy variables of integration
δ_e	elevator deflection
δ_f	flap deflection
θ	pitch angle
σ_i	time at which i th information update takes place
τ_k	space of admissible information update intervals at σ_k
T_k	set of k time interval sequences which are admissible for k -stage process, that is, the Cartesian product $\tau_1 \times \tau_2 \times \dots \times \tau_k$
ϕ	state transition matrix in difference equation representation of airplane dynamics

Subscripts:

i, j, k	indices indicating information update interval
N	last stage of N stage process
$\tau_k T_{k-1}$	space of admissible k sample intervals conditioned on the process T_{k-1}
T_k	operation to be performed over space of information update process
0	initial value

A dot over a symbol indicates differentiation with respect to time. The superscript T indicates transpose of the matrix.

MODELING OF RANDOMLY SAMPLED SYSTEMS

The purpose of this section is to present a model which is useful in describing the stochastic information transfer process in a multiple-processor control system. Consider the continuous time invariant dynamical system represented by the linear differential equation

$$\dot{x} = Ax + Bu \tag{1}$$

where x is an n -dimensional vector representing the system states, u is an m -dimensional vector representing the control inputs, A is an $n \times n$ matrix describing the dynamics of the system, and B is an $n \times m$ matrix describing

the control effectiveness. The state information is assumed to be updated in the controller at discrete points in time σ_k . The sequence σ_k is defined as the sum of a stochastic process t_k in the following sense

$$\sigma_k = \sigma_0 + \sum_{i=1}^k t_i \quad (2)$$

where t_k is an element of the set τ_k which is the set of admissible sample time intervals. Referring to the sketch on the right, which illustrates the stochastic sampling nomenclature that is followed throughout this report, one finds that σ_0 denotes the starting time, t_k denotes the k th time interval between two consecutive information updates, and σ_k is the time that the k th information update takes place. Since the time interval between two consecutive information updates cannot be negative, the sample space of the stochastic process τ_i for $i = 1, 2, \dots, N$ is restricted to sets of positive real numbers. There is, however, no restriction on the statistical nature of the process. The set T_k of information update sequences T_k which are admissible for a k -stage process is the Cartesian product of τ_i , that is,

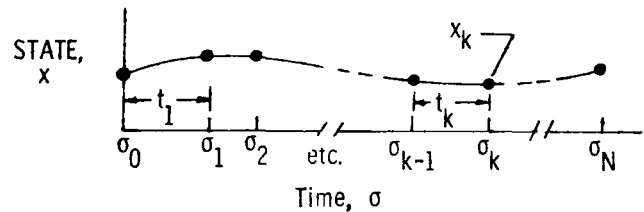

$$t_k \in \tau_k$$

$$T_k = t_1, \dots, t_k$$

The average of a quadratic integral in the state and control is defined to be the cost functional for the N -interval process to achieve the desired system performance. A cost functional is assumed in the following form:

$$J = \frac{1}{2} E_{T_N} \left\{ \int_{\sigma_0}^{\sigma_N} [x^T(t) Q x(t) + u^T(t) R u(t)] dt + x^T(\sigma_N) S x(\sigma_N) \right\} \quad (3)$$

The cost functional can be expressed as the sum of N integrals by dividing the total time into N intervals, namely,

$$J = \frac{1}{2} E_{T_N} \left\{ x^T(\sigma_N) S x(\sigma_N) + \sum_{k=0}^{N-1} \int_{\sigma_k}^{\sigma_{k+1}} [x^T(t) Q x(t) + u^T(t) R u(t)] dt \right\} \quad (4)$$

If control inputs are further restricted to piecewise constant functions of time that change only at sampling instants σ_k , that is, given the sequence u_k , $k = 1, 2, \dots, N$, then

$$u(t) = u_k \quad (\sigma_k \leq t < \sigma_{k+1}) \quad (5)$$

$$x_{k+1} = \phi_k x_k + \Gamma_k v_k \quad (x_k \triangleq x(\sigma_k))$$

$$J = \frac{1}{2} E_{T_N} \left\{ x_N^T S x_N + \sum_{k=0}^{N-1} [x_k^T Q_k x_k + v_k^T R_k v_k] \right\}$$

$$\phi_k = \phi(t_{k+1}) - \Gamma(t_{k+1}) R_k^{-1} W_k^T$$

$$\phi(\gamma) = e^{A\gamma}$$

$$\Gamma_k = \Gamma(t_{k+1})$$

$$\Gamma(\gamma) = \int_0^\gamma e^{A\delta} B d\delta$$

$$Q_k = \int_0^{t_{k+1}} \phi^T(\gamma) Q \phi(\gamma) d\gamma + W_k R^{-1} W_k^T$$

$$R_k = \int_0^{t_{k+1}} [R + \Gamma^T(\gamma) Q \Gamma(\gamma)] d\gamma$$

$$W_k = -\int_0^{t_{k+1}} \phi^T(\gamma) Q \Gamma(\gamma) d\gamma$$

(6)

Equations (6) were obtained by using the techniques of reference 7 with the transformation

$$v_k = u_k + R_k^{-1} W_k^T x_k \quad (7)$$

employed to eliminate the cross-product terms $x_k^T W_k u_k$ that would otherwise appear in the cost function representation.

OPTIMAL CONTROL OF RANDOMLY SAMPLED SYSTEMS

The main results on optimal control of randomly sampled systems can be summarized in the following theorem.

Theorem 1: For an N-stage stochastic process model described in equations (6), the sequence v_k (eq. (7)) which minimizes J given that the distribution of the stochastic process $\{t_k\}$ is governed by the following recursive relations:

$$\left. \begin{aligned} J_{N-k,N} &= x_{N-k}^T P_k x_{N-k} \\ P_k &= E_{T_{N-k+1} | T_{N-k}} \left\{ Q_{N-k} + K_{N-k}^T R_{N-k}^{-1} K_{N-k} + [\phi_{N-k} + \Gamma_{N-k} K_{N-k}]^T P_{k-1} [\phi_{N-k} + \Gamma_{N-k} K_{N-k}] \right\} \\ K_{N-k} &= - \left\{ E_{T_{N-k+1} | T_{N-k}} \left[R_{N-k} + \Gamma_{N-k}^T P_{k-1} \Gamma_{N-k} \right] \right\}^{-1} E_{T_{N-k+1} | T_{N-k}} \left[\Gamma_{N-k}^T P_{k-1} \phi_{N-k} \right] \end{aligned} \right\} \quad (8)$$

where for notational simplification equations (8) have been written as $P_k \triangleq P_k | T_{N-k}$ and $K_{N-k} \triangleq K_{N-k} | T_{N-k}$. For the proof, see the appendix.

Markov Process Assumption

The statistical property characterizing a Markov process is that the present state of the system contains all relevant statistics pertaining to the future. Mathematically, a process x_1, x_2, \dots is called a Markov chain if

$$P(x_{N+1} | x_1, x_2, \dots, x_N) = P(x_{N+1} | x_N) \quad (9)$$

If $T_k = \{t_1 \dots t_k\}$ with T_k as its sample space and if τ_k is the sample space of t_k , then, assuming a Markov chain,

$$p_{\tau_k | T_{k-1}}(t_k | T_{k-1}) = p_{\tau_k | \tau_{k-1}}(t_k | t_{k-1}) \quad (10)$$

This equation states that the present sampling interval determines the probability of the next sampling interval in the future. For such a process, a transition mechanism can be defined and the a priori joint density $p_{T_k}(T_k)$ can be written as

$$\begin{aligned} p_{T_k}(T_k) &= p_{\tau_k, T_{k-1}}(t_k, T_{k-1}) \\ &= p_{\tau_k | T_{k-1}}(t_k | T_{k-1}) p_{T_{k-1}}(T_{k-1}) \\ &= \prod_{i=1}^k p_{\tau_i | T_{i-1}}(t_i | T_{i-1}) p_{\tau_0}(t_0) \\ &= \prod_{i=1}^k p_{\tau_i | \tau_{i-1}}(t_i | t_{i-1}) p_{\tau_0}(t_0) \end{aligned}$$

Hence, for a Markov process, specification of the a priori density function $p_{\tau_0}(t_0)$ together with the transition probabilities $p_{\tau_k | \tau_{k-1}}(t_k | t_{k-1})$ completely determines the distribution of the process. As a result, equations (8) can be modified to replace conditioning on T_{N-k} by conditioning on τ_{N-k} .

Theorem 2: The probabilistic Riccati equations with Markov assumption are

$$\begin{aligned} J_{N-k, N} &= x_{N-k}^T P_k x_{N-k} \\ P_k &= E_{\tau_{N-k+1} | \tau_{N-k}} \left\{ Q_{N-k} + K_{N-k}^T R_{N-k} K_{N-k} + [\phi_{N-k} + \Gamma_{N-k} K_{N-k}]^T P_{k-1} [\phi_{N-1} + \Gamma_{N-k} K_{N-k}] \right\} \\ K_{N-k} &= - \left\{ E_{\tau_{N-k+1} | \tau_{N-k}} \left[R_{N-k} + \Gamma_{N-k}^T P_{k-1} \Gamma_{N-k} \right] \right\}^{-1} E_{\tau_{N-k+1} | \tau_{N-k}} \left[\Gamma_{N-k}^T P_{k-1} \phi_{N-k} \right] \end{aligned}$$

where $P_k \triangleq P_k | t_{N-k}$ and $K_{N-k} \triangleq K_{N-k} | t_{N-k}$.

The computation of a solution to these probabilistic Riccati equations is simpler than that for equations (8) because the stochastic process is more restricted. However, if the process is dependent on time and if the sample space of $\{t_k\}$ is continuous, integration still has to be performed at each stage of the recursive Riccati equation. The computational time for the Markov case can be exorbitant. On the other hand, if the process is stationary (independent of time) and the sample space of $\{t_k\}$ is continuous, integration for the expectation operator has to be performed only once before solving the

probabilistic Riccati equations. A simpler case in which the process is stationary and the sample space is discrete is discussed next.

Discrete Stationary Markov Processes

If the sample space τ_k is discrete and finite and if the conditional probability is stationary, then the transition mechanism can be represented by the matrix

$$T = \left\{ T_{ij} \right\} \equiv \left\{ P(t_k = s_j | t_{k-1} = s_i) \right\}$$

for a given sample space $\tau_k = \{s_1, s_2, \dots, s_M\}$ for $k = 1, 2, \dots, N$. In that case, the optimal solution consists of M gain sensitivity matrices at each stage so that

$$P_k | \tau_{N-k} = \left\{ P_k | s_1, P_k | s_2, \dots, P_k | s_M \right\}$$

and

$$K_{N-k} | \tau_{N-k} = \left\{ K_{N-k} | s_1, K_{N-k} | s_2, \dots, K_{N-k} | s_M \right\}$$

Also, the expectation operators can be replaced by finite summations such as

$$\left\{ E_{\tau_{N-k+1} | \tau_{N-k}} (f) \right\} \Big|_{t_{N-k} = s_i} = \sum_{j=1}^M f(s_j) P(t_{N-k+1} = s_j | t_{N-k} = s_i) = \sum_{j=1}^M T_{ij} f(s_j)$$

where f is an arbitrary function.

For simplification, the following notation is used:

$$\left. \begin{aligned} Q_{N-k,i} &= Q(t_{N-k} = s_i) = Q_i \\ R_{N-k,i} &= R(t_{N-k} = s_i) = R_i \\ \phi_{N-k,i} &= \phi(t_{N-k} = s_i) = \phi_i \\ \Gamma_{N-k,i} &= \Gamma(t_{N-k} = s_i) = \Gamma_i \end{aligned} \right\} \quad (i = 1, 2, \dots, M)$$

where Q_i , R_i , ϕ_i , and Γ_i are defined in equations (6). The probabilistic equations can now be written in difference equation form.

Theorem 3: The recursive relations for discrete stationary Markov processes are

$$\left. \begin{aligned}
 J_{N-k,N} &= x_{N-k}^T P_k | i x_{N-k} \\
 P_k | i &= \sum_{j=1}^M T_{i|j} \left\{ Q_{N-k,j} + K_{N-k|j}^T R_{N-k,j} K_{N-k|j} + \left[\phi_{N-k,j} + \Gamma_{N-k,j} K_{N-k|j} \right]^T P_{k-1,j} \left[\phi_{N-k,j} + \Gamma_{N-k,j} K_{N-k|j} \right] \right\} \\
 K_{N-k|j} &= - \left\{ \sum_{j=1}^M T_{i|j} \left[R_{N-k,j} + \Gamma_{N-k,j}^T P_{k-1|j} \Gamma_{N-k,j} \right] \right\}^{-1} \cdot \left\{ \sum_{m=1}^M T_{i|m} \left[\bar{r}_{N-k,m}^T P_{k-1|m} \phi_{N-k,m} \right] \right\}
 \end{aligned} \right\} (11)$$

The recursive computations required to generate the optimal control for these probabilistic Riccati equations are similar to that for a deterministic Riccati equation. However, the probabilistic Riccati equation also requires the prior distribution function for t_0 , namely $P_{T_0}(t_0)$, to initiate the computation. Furthermore, at each stage of the recursive computation, M gain matrices and M sensitivity matrices must be calculated. The computations required to generate the optimal control sequences for the randomly sampled system is equivalent to solving M Riccati equations coupled by transition probabilities. If the transition probability matrix is an identity matrix, then the corresponding Riccati equations are decoupled. This case corresponds to uniform sampling with probability one with the sampled time determined by the first sample. Each decoupled probabilistic Riccati equation reduces to a deterministic Riccati equation with uniform sampling. The solution with N and k infinite is called the quasi-steady-state solution. The quasi-steady-state solution is obtained as the M gain matrices approach constant values. In general, the M gain matrices have different quasi-steady-state values. For the purpose of computing quasi-steady-state gains, the a priori distribution function can be chosen to be

$$P_{T_0}(t_0=s_i) = 1$$

and

$$P_{T_0}(t_0=s_i) = 0$$

This is equivalent to selecting an initial sampling interval $t_0 = s_i$ to start the process. Hence, there are generally M simulations of interest in the class of distributions considered, one for each element of the discrete sample space τ_0 . The optimal cost is not generally asymptotically stationary; that is, the cost depends on the initial sampling interval chosen, for example, the case where $T = I$, because all subsequent sampling intervals are the same as the initial sampling interval. Each simulation requires that the initial conditions $x(0)$ and the initial sample interval t_0 contained in $\tau = \{s_1, \dots, s_M\}$ be given. If the quasi-steady-state gains are used and if $t_0 = s_i$, then the control $u(\sigma_0)$ applied over the interval (σ_0, σ_1) of unknown and stochastic duration t_1 is given by $u(\sigma_0) - K_i x(\sigma_0)$, where $K_i = K_{N-k, i}$ as N and k become infinite with $i = 1, 2, \dots, M$. Subsequent control actions are computed according to $u_k = K_i x_k$ if $t_{k-1} = s_i$. Figure 1 is a flow chart of the closed-loop control logic using quasi-steady-state feedback. The next section illustrates the application of the quasi-steady-state theory to flight control system design.

EXAMPLE APPLICATION OF OPTIMAL STOCHASTIC REGULATOR TO AIRPLANE

The theory developed in the previous section has been applied to the design of a control system for the longitudinal control of the F-8 DFBW airplane. The function of the control system is to produce elevator and flap commands to keep the airplane in steady level flight in the presence of disturbances. A four-dimensional model is used to design and evaluate the control system. It is obtained from linearizing the longitudinal equations of motion of the airplane about the equilibrium flight condition at an altitude of 6100 m (20 000 ft) and a 0.67 Mach number. The state vector is defined as $x^T = (V, \alpha, q, \theta)$ and the control vector is $u^T = (\delta_f, \delta_e)$. Using these definitions, the equation of motion of the airplane takes the form of equation (1) where the A and B matrices are shown in table I.

Figure 2 shows the unaugmented response of the airplane to initial conditions. The motion is characterized by two oscillatory modes, one of short-period oscillation and the other a long period called the phugoid. For this example, the weighting matrices Q and R have been selected so that only elevator deflections are used to control the short-period mode and so that only the short-period mode is regulated. This leads to high weights on the α and q error terms and high weights on the flap weight term. The V and θ weighting terms were small so as not to overcontrol the long-period mode. The specific values of Q and R for this example are $Q = \text{Diag}(0.25, 3.0, 3.0, 0.001)$ and $R = \text{Diag}(4.0, 0.4)$. The sample space τ was taken to be $\tau = \{0.02, 0.03, 0.1\}$ and the transition mechanism was

$$T = \begin{bmatrix} 0.95 & 0.05 & 0 \\ 0 & 0.8 & 0.2 \\ 0.7 & 0 & 0.3 \end{bmatrix}$$

Hence, if the sampling intervals at t_{k-1} is s_1 the probability that $t_k = s_1$ is 0.95, the probability that $t_k = s_2$ is 0.05, and the probability that $t_k = s_3$ is zero. Figure 3 is a graphical representation of the transition mechanism. The characteristic of this transition mechanism is that it leads to a process that is cyclic; that is, it tends to change gradually from the fastest sampling interval to the slowest and back to the fastest.

For the example, the stochastic Ricatti equations (eqs. (11)) have been solved iteratively to obtain the quasi-steady-state gains and sensitivity matrices shown in table I. The optimal stochastic closed-loop system has been simulated using stochastic sequences. Figure 4 shows the response of the system using the optimal stochastic closed-loop control system corresponding to the flow chart of figure 1. For comparison, the optimal deterministic solution for a known information update interval $s_1 = 0.02$ sec has also been simulated. The solution corresponding to the deterministic and known update interval was obtained by using a transition matrix $T = I$ in equations (11). Figure 5 shows the response of the system using optimal uniform update intervals. The trajectories differ insignificantly; this indicates that little is lost in the stochastic information update process provided the stochastic nature of the process is accounted for in the actuation logic. The expected value of the cost of the process can, of course, be evaluated with the sensi-

tivity matrices according to the formula $x_0^T P_{\infty} x_0$. That value is 0.5097 for uniform sampling and 0.5160 for stochastic sampling assuming $t_0 = s_1 = 0.02$ with the same initial conditions used in figures 2, 4, and 5. For comparison the cost during a 10-sec simulation with no control input using the same initial conditions is 1.427. To study the stochastic behavior of the cost, 50 Monte Carlo simulations were performed for the optimal feedback system and each non-optimal feedback system. Table II summarizes the statistics of the simulations. The ij element of the table is the number of transitions from s_i to s_j divided by the total number of s_i -intervals in the 50 simulations N_i . Compare the T-matrix with the entries of table II. The agreement is best for the first row (corresponding to s_1) because s_1 is the most frequent interval used in the 50 simulations. The optimization results are summarized in table III. They are consistent with the theory; that is, in the randomly sampled system, the optimal stochastic gains give the lowest average cost (0.5174) over all other gains including those calculated for the uniformly sampled system.

CONCLUDING REMARKS

In this paper the problem of accounting for variability in information update time intervals to actuator type control units for microprocessor-based flight control systems has been addressed. The problem was cast as a stochastic sampling regulator wherein the information update process was random. In this way variable sample time systems are treated as a stochastic regulator problem. The optimal control policy was shown to satisfy a stochastic Ricatti equation. Its use has been illustrated for the control of the longitudinal motions of the F-8 DFBW airplane. For the 50 Monte Carlo simulations conducted, the performance of the system using a stochastic information update process was very close to that obtained by using a Kalman regulator designed for and using the

deterministic and shortest sample time in the admissible set of the stochastic case. This conclusion is supported both by theoretical computations using the cost sensitivity matrices and by simulations.

Langley Research Center
National Aeronautics and Space Administration
Hampton, VA 23665
September 12, 1980

APPENDIX

STOCHASTIC OPTIMIZATION - PROOF OF THEOREM 1

The proof of theorem 1 will be inductive following the method of reference 2 using dynamic programming. Consider the problem of selecting the sequence v_k to optimize J if the distributions of the stochastic process $\{t_k\}$ are given. First a single-stage optimization over the interval $t \in (\sigma_N - t_N, \sigma_N)$ is considered and then the result to all N stages is generalized. The following sketch may assist the reader in understanding the relationships of the sequences x_k, v_k, t_k, σ_k for the N -stage optimization problem; the sequences of the sketch correspond to equations (6) and (7) where $J = J_{0,N}$.

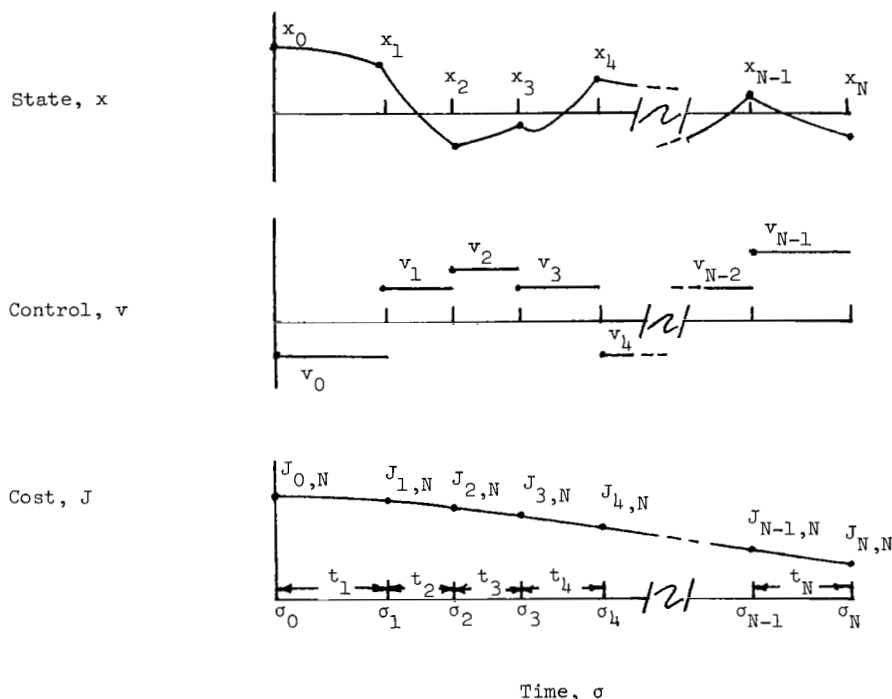

Single-Stage Process

Referring to the system described by equations (6) and (7), consider the last stage of the process which makes a transition from σ_{N-1} to σ_N with an interval t_N . The optimal control of the stage produces a cost

$$J_{N-1,N} = \frac{1}{2} \min_{v_{N-1}} E_{t_N} \Big|_{T_{N-1}} \left\{ x_{N-1}^T Q_{N-1} x_{N-1} + v_{N-1}^T R_{N-1} v_{N-1} + x_N^T P_0 x_N \right\}$$

APPENDIX

where $P_0 \triangleq S$. The control v_{N-1} is statistically independent of the t_N -process. The minimum of $J_{N-1,N}$ with respect to v_{N-1} is obtained by setting $\frac{\partial J_{N-1,N}}{\partial v_{N-1}} = 0$. Thus, since x_{N-1} is also statistically independent of the t_N -process,

$$E_{\tau_N | T_{N-1}} \left\{ R_{N-1} v_{N-1} + \Gamma_{N-1}^T P_0 (\phi_{N-1} x_{N-1} + \Gamma_{N-1} v_{N-1}) \right\} = 0$$

so that

$$v_{N-1} = - \left\{ E_{\tau_N | T_{N-1}} \left[R_{N-1} + \Gamma_{N-1}^T P_0 \Gamma_{N-1} \right] \right\}^{-1} E_{\tau_N | T_{N-1}} \left[\Gamma_{N-1}^T P_0 \phi_{N-1} x_{N-1} \right]$$

Hence, $v_{N-1} = K_{N-1} | T_{N-1} x_{N-1}$ where the gain $K_{N-1} | T_{N-1}$ is

$$K_{N-1} | T_{N-1} = - \left\{ E_{\tau_N | T_{N-1}} \left[R_{N-1} + \Gamma_{N-1}^T P_0 \Gamma_{N-1} \right] \right\}^{-1} E_{\tau_N | T_{N-1}} \left[\Gamma_{N-1}^T P_0 \phi_{N-1} \right]$$

The cost resulting from application of the optimal control can be evaluated as

$$\begin{aligned} J_{N-1,N} &= \frac{1}{2} E_{\tau_N | T_{N-1}} \left\{ x_{N-1}^T Q_{N-1} x_{N-1} + v_{N-1}^T R_{N-1} v_{N-1} + x_N^T P_0 x_N \right\} \\ &= \frac{1}{2} E_{\tau_N | T_{N-1}} \left\{ x_{N-1}^T Q_{N-1} x_{N-1} + (K_{N-1} x_{N-1})^T R_{N-1} K_{N-1} x_{N-1} \right. \\ &\quad \left. + (\phi_{N-1} x_{N-1} + \Gamma_{N-1} K_{N-1} x_{N-1})^T P_0 (\phi_{N-1} x_{N-1} + \Gamma_{N-1} K_{N-1} x_{N-1}) \right\} \end{aligned}$$

where for notational simplification $K_{N-1} \triangleq K_{N-1} | T_{N-1}$. Hence the cost takes the form

$$J_{N-1,N} = \frac{1}{2} x_{N-1}^T P_1 x_{N-1}$$

where

$$P_1 \triangleq P_1 | T_{N-1} = E_{\tau_N | T_{N-1}} \left\{ Q_{N-1} + K_{N-1}^T R_{N-1} K_{N-1} + (\phi_{N-1} + \Gamma_{N-1} K_{N-1})^T P_0 (\phi_{N-1} + \Gamma_{N-1} K_{N-1}) \right\}$$

APPENDIX

k-Stage Process

The final two intervals of the process have an optimal cost of

$$J_{N-2,N} = \frac{1}{2} \min_{v_{N-1}, v_{N-2}} \left\{ E_{\tau_N, \tau_{N-1} | T_{N-2}} \left[x_N^T S x_N + \sum_{k=N-2}^{N-1} x_k^T Q_k x_k + v_k^T R_k v_k \right] \right\}$$

$$J_{N-2,N} = \frac{1}{2} \min_{v_{N-1}, v_{N-2}} \left\{ E_{\tau_N, \tau_{N-1} | T_{N-2}} \left[x_{N-2}^T Q_{N-2} x_{N-2} + v_{N-2}^T R_{N-2} v_{N-2} \right] \right. \\ \left. + E_{\tau_N, \tau_{N-1} | T_{N-2}} \left[x_{N-1}^T Q_{N-1} x_{N-1} + v_{N-1}^T R_{N-1} v_{N-1} + x_N^T P_0 x_N \right] \right\}$$

$$J_{N-2,N} = \frac{1}{2} \min_{v_{N-2}} \left\{ E_{\tau_{N-1} | T_{N-2}} \left[x_{N-2}^T Q_{N-2} x_{N-2} + v_{N-2}^T R_{N-2} v_{N-2} \right] \right\} \\ + \min_{v_{N-1}} \left\{ E_{\tau_N | T_{N-1}} \left[x_{N-1}^T Q_{N-1} x_{N-1} + v_{N-1}^T R_{N-1} v_{N-1} + x_N^T P_0 x_N \right] \right\}$$

The later equation follows from the property of distributions

$$P_{\tau_N, \tau_{N-1} | T_{N-2}} = P_{\tau_N | \tau_{N-1}, T_{N-2}} P_{\tau_{N-1} | T_{N-2}} \\ = P_{\tau_N | T_{N-1}} P_{\tau_{N-1} | T_{N-2}}$$

from which

$$E_{\tau_N, \tau_{N-1} | T_{N-2}} (f) = E_{\tau_{N-1} | T_{N-2}} \left[E_{\tau_N | T_{N-1}} (f) \right]$$

Hence,

$$J_{N-2,N} = \frac{1}{2} \min_{v_{N-2}} \left\{ E_{\tau_{N-1} | T_{N-2}} \left[x_{N-2}^T Q_{N-2} x_{N-2} + v_{N-2}^T R_{N-2} v_{N-2} + x_{N-1}^T P_1 x_{N-1} \right] \right\}$$

APPENDIX

with the last equation an analogy can be drawn with the single-stage process and immediately the conclusion is that

$$J_{N-2,N} = x_{N-2}^T P_2 x_{N-2}$$

$$P_2 = E_{\tau_{N-1} | T_{N-2}} \left\{ Q_{N-2} + K_{N-2}^T R_{N-2} K_{N-2} + \left[\phi_{N-2} + \Gamma_{N-2} K_{N-2} \right]^T P_1 \left[\phi_{N-2} + \Gamma_{N-2} K_{N-2} \right] \right\}$$

$$K_{N-2} = - \left\{ E_{\tau_{N-1} | T_{N-2}} \left[R_{N-2} + \Gamma_{N-2}^T P_1 \Gamma_{N-2} \right] \right\}^{-1} E_{\tau_{N-1} | T_{N-2}} \left[\Gamma_{N-2}^T P_1 \phi_{N-2} \right]$$

where $P_2 \triangleq P_2 | T_{N-2}$ and $K_{N-2} = K_{N-2} | T_{N-2}$. Hence for a k-stage process, mathematical induction leads to equations (8) and completes the proof of theorem 1.

REFERENCES

1. Napjus, George A.: Recent Advances in Strapdown Inertial Navigation. 1975 IEEE Intercon Conference Record, c.1975, paper 35/1.
2. Gunckel, T. L., II; and Franklin, Gene F.: A General Solution for Linear, Sampled-Data Control. Trans. ASME, Set. D: J. Basic Eng., vol. 85, no. 2, June 1963, pp. 197-203.
3. Dorato, Peter; and Levis, Alexander H.: Optimal Linear Regulator: The Discrete Time Case. IEEE Trans. Autom. Control, vol. AC-16, no. 6, Dec. 1971, pp. 613-620.
4. Ho, Y. C.; and Chu, K. C.: Information Structure in Dynamic Multi-Person Control Problems. Automatica, vol. 10, no. 4, July 1974, pp. 341-351.
5. Witsenhausen, Hans S.: Separation of Estimation and Control for Discrete Time Systems. Proc. IEEE, vol. 59, no. 11, Nov. 1971, pp. 1557-1566.
6. Caglayan, Alper K.; and VanLandingham, Hugh F.: Digital Flight Control Systems. NASA CR-145246, 1977.
7. Armstrong, Ernest S.; and Caglayan, Alper K.: An Algorithm for the Weighting Matrices in the Sampled-Data Optimal Linear Regulator Problem. NASA TN D-8372, 1976.

Table I. - SYSTEM MATRICES AND SOLUTION MATRICES

$$A = \begin{bmatrix} -9.529E-3 & -1.283E+1 & 0 & -3.217E+1 \\ -1.175E-4 & -9.782E-1 & 1 & 0 \\ 3.324E-7 & -4.723E+0 & -4.729E-1 & 0 \\ 0 & 0 & 1 & 0 \end{bmatrix}$$

$$B = \begin{bmatrix} -6.554E+0 & 0 \\ -2.253E-1 & -1.513E-1 \\ -1.539E+0 & -1.333E+1 \\ 0 & 0 & 0 \end{bmatrix}$$

$$P_{\infty}|_{s_1} = \begin{bmatrix} 1.197E-4 & 1.108E-3 & -2.454E-4 & -9.406E-3 \\ 1.108E-3 & 1.432E+0 & 1.804E-3 & -4.011E-1 \\ -2.454E-4 & 1.804E-3 & 8.501E-2 & 4.311E-2 \\ -9.406E-3 & -4.011E-1 & 4.311E-2 & 1.769E+0 \end{bmatrix}$$

$$K_{\infty}|_{s_1} = \begin{bmatrix} 1.922E-4 & -5.379E-3 \\ 1.888E-2 & 3.046E-1 \\ 2.227E-2 & 1.941E+0 \\ -2.614E-2 & 8.928E-1 \end{bmatrix}$$

$$P_{\infty}|_{s_2} = \begin{bmatrix} 1.199E-4 & 1.095E-3 & -3.039E-4 & -9.437E-3 \\ 1.095E-4 & 1.434E+0 & 6.261E-3 & -3.991E-1 \\ -3.039E-4 & 6.261E-3 & 1.040E-1 & 5.277E-2 \\ -9.437E-3 & -3.991E-1 & 5.277E-2 & 1.777E+0 \end{bmatrix}$$

$$K_{\infty}|_{s_2} = \begin{bmatrix} 2.197E-4 & -2.991E-3 \\ 7.300E-2 & 1.200E-1 \\ 1.413E-2 & 1.204E+0 \\ -3.098E-2 & 4.991E-1 \end{bmatrix}$$

$$P_{\infty}|_{s_3} = \begin{bmatrix} 1.198E-4 & 1.097E-3 & -2.746E-4 & -9.419E-3 \\ 1.097E-3 & 1.433E+0 & 5.478E-3 & -3.994E-1 \\ -2.746E-4 & 5.478E-3 & 9.607E-2 & 4.793E-2 \\ -9.419E-3 & -3.994E-2 & 4.793E-2 & 1.771E+0 \end{bmatrix}$$

$$K_{\infty}|_{s_3} = \begin{bmatrix} 2.257E-4 & -2.579E-3 \\ 7.443E-2 & -5.938E-2 \\ 1.134E-2 & 9.441E-1 \\ -3.186E-2 & 4.314E-1 \end{bmatrix}$$

TABLE II.- RELATIVE FREQUENCY OF TRANSITIONS FOR
50 MONTE CARLO SIMULATIONS

T =	0.9158	0.0482	0	N_1	= 14 661
	0	0.7990	0.2010	N_2	= 3 513
	0.6888	0	0.3112	N_3	= 1 025
				$\sum N_i$	= 19 199

TABLE III.- RESULTS OF MONTE CARLO SIMULATIONS
[50 random runs of 10-sec duration]

Gain	Average cost
Optimal gain for 0.02-sec uniformly sampled system . . .	0.6158
Optimal gain for 0.03-sec uniformly sampled system . . .	0.5526
Optimal gain for 0.10-sec uniformly sampled system . . .	0.5372
Unaugmented system	1.427
Optimal stochastic gains	0.5174

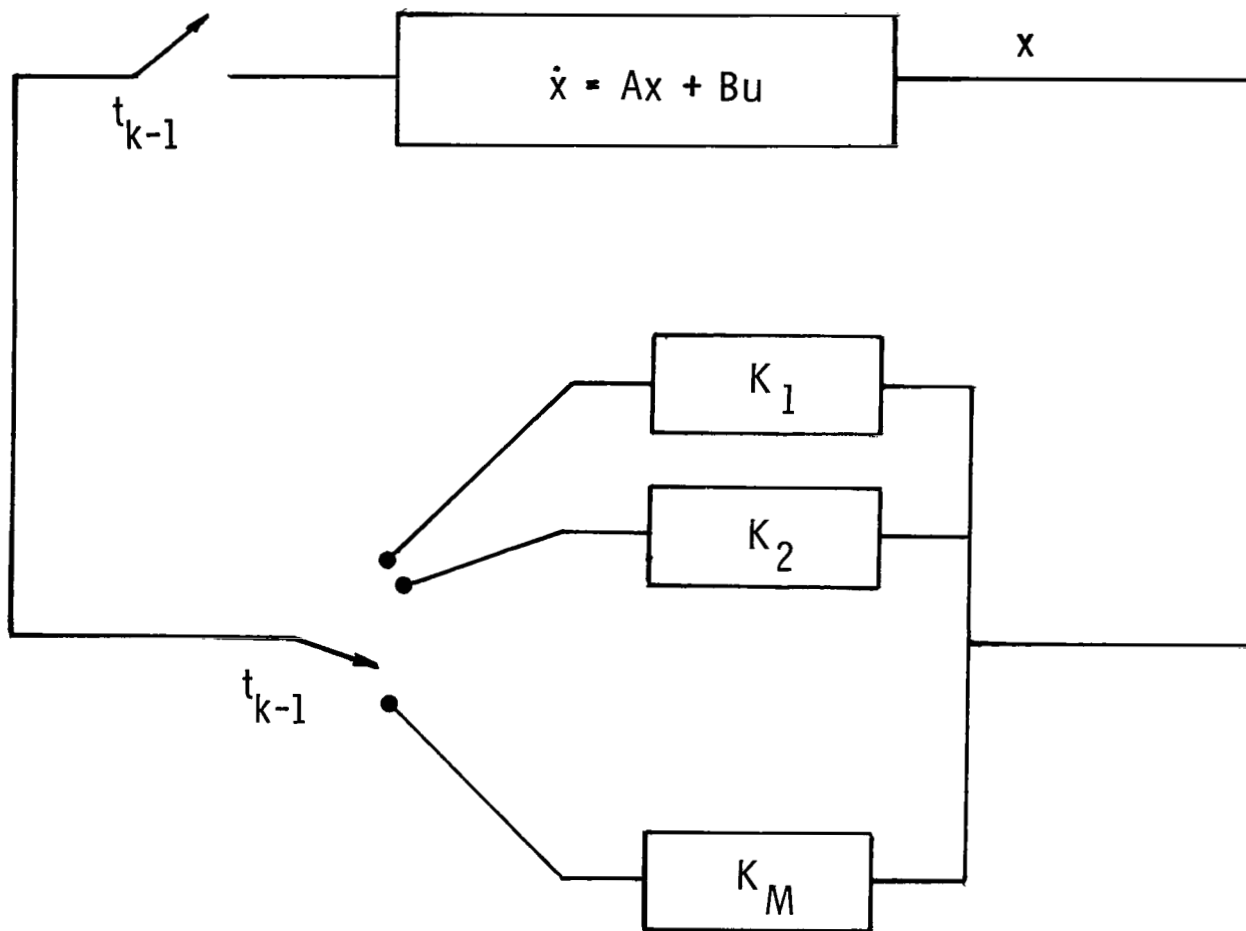

Figure 1.- Closed-loop system using quasi-steady-state feedback.

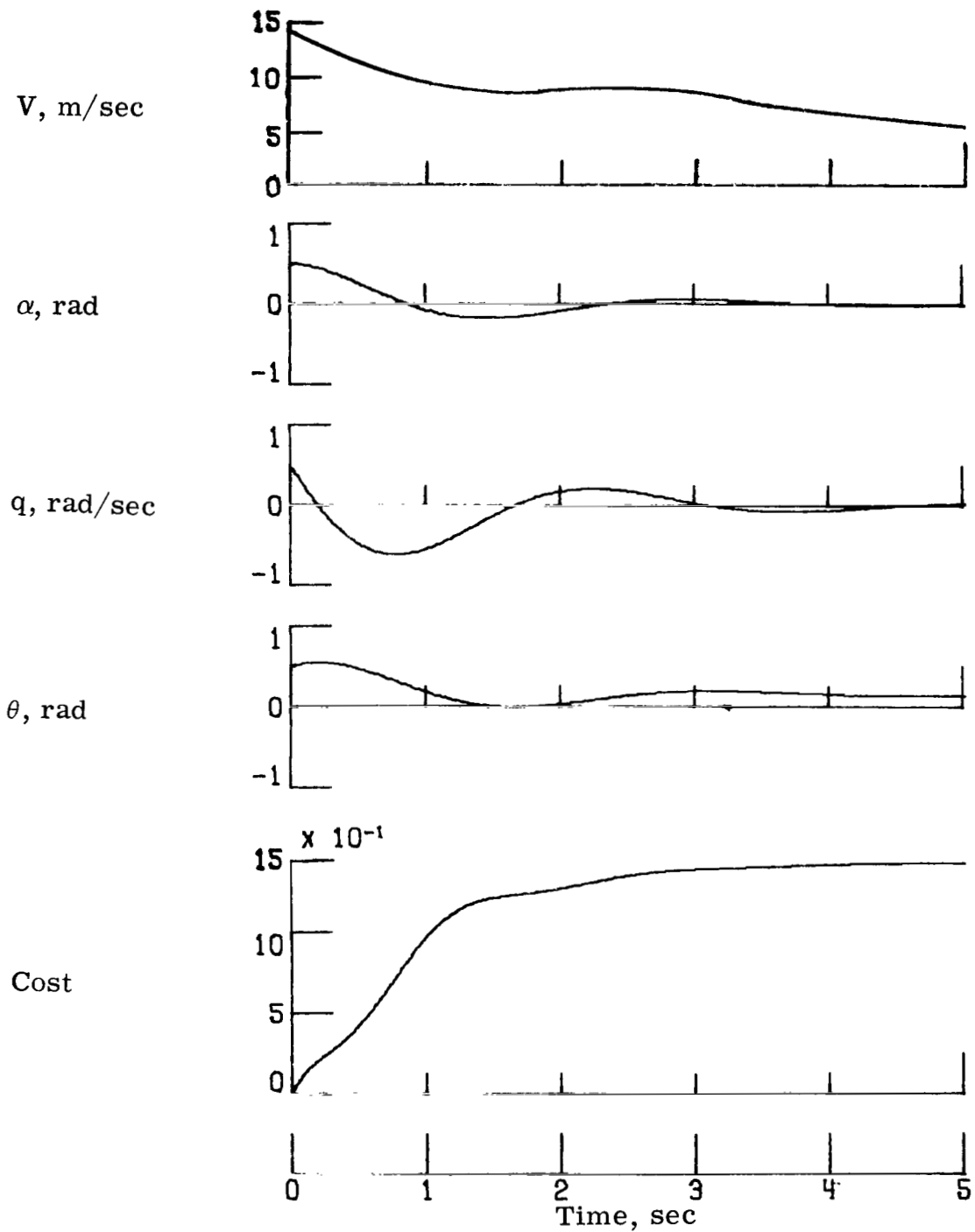

Figure 2.- Unaugmented response of airplane.

$$T = \begin{bmatrix} .95 & .05 & 0 \\ 0 & .8 & .2 \\ .7 & 0 & .3 \end{bmatrix}$$

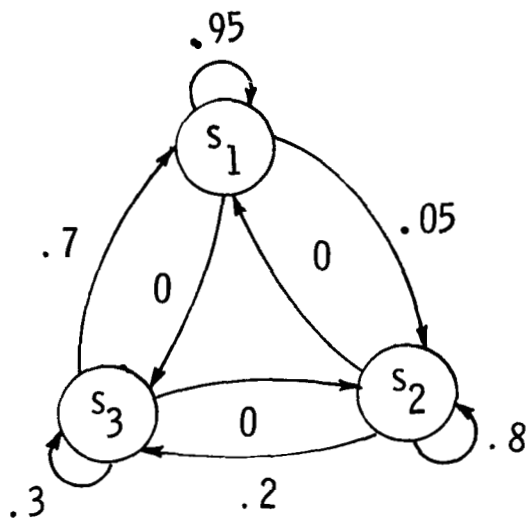

Figure 3.- Probabilistic transition graph.

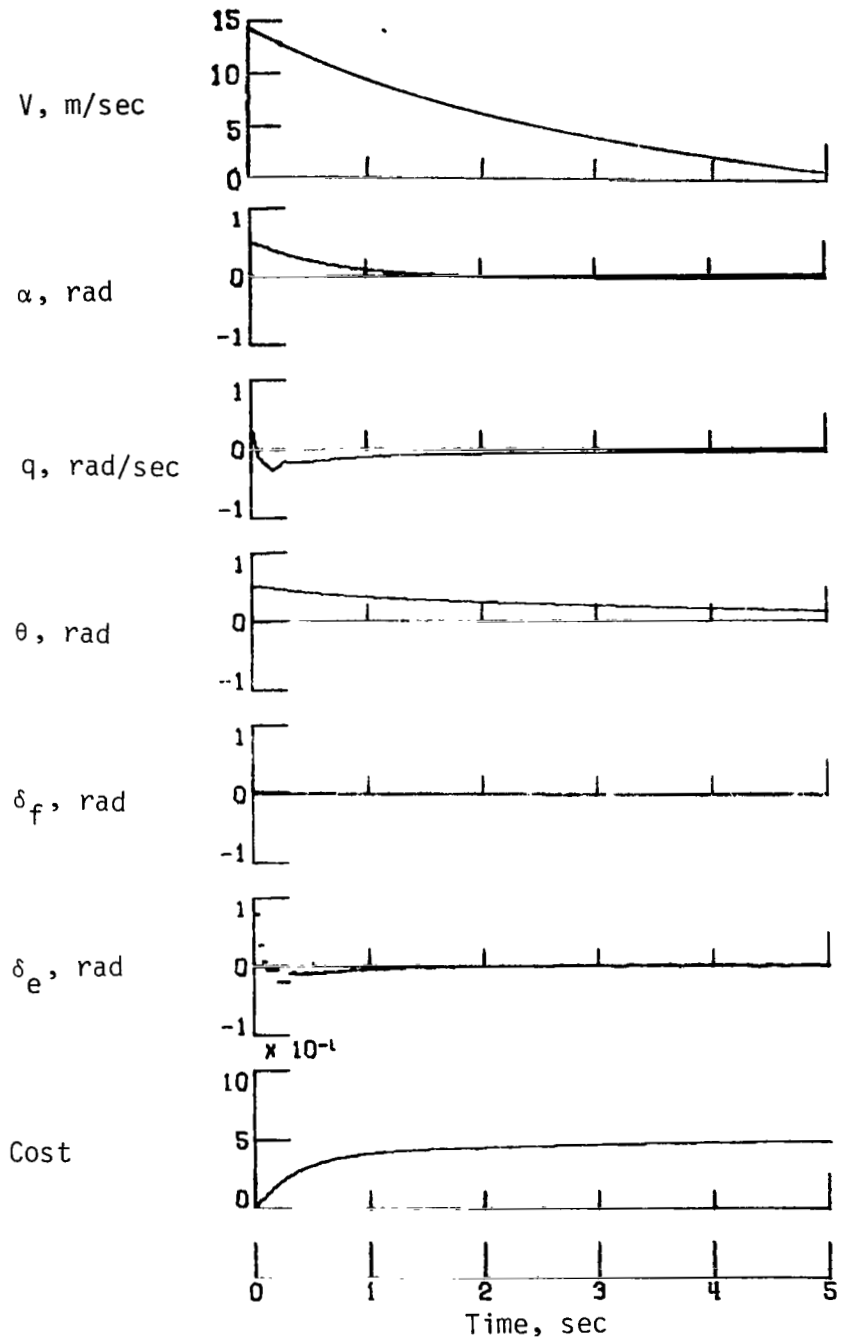

Figure 4.- Response of randomly sampled system using optimal stochastic gains.

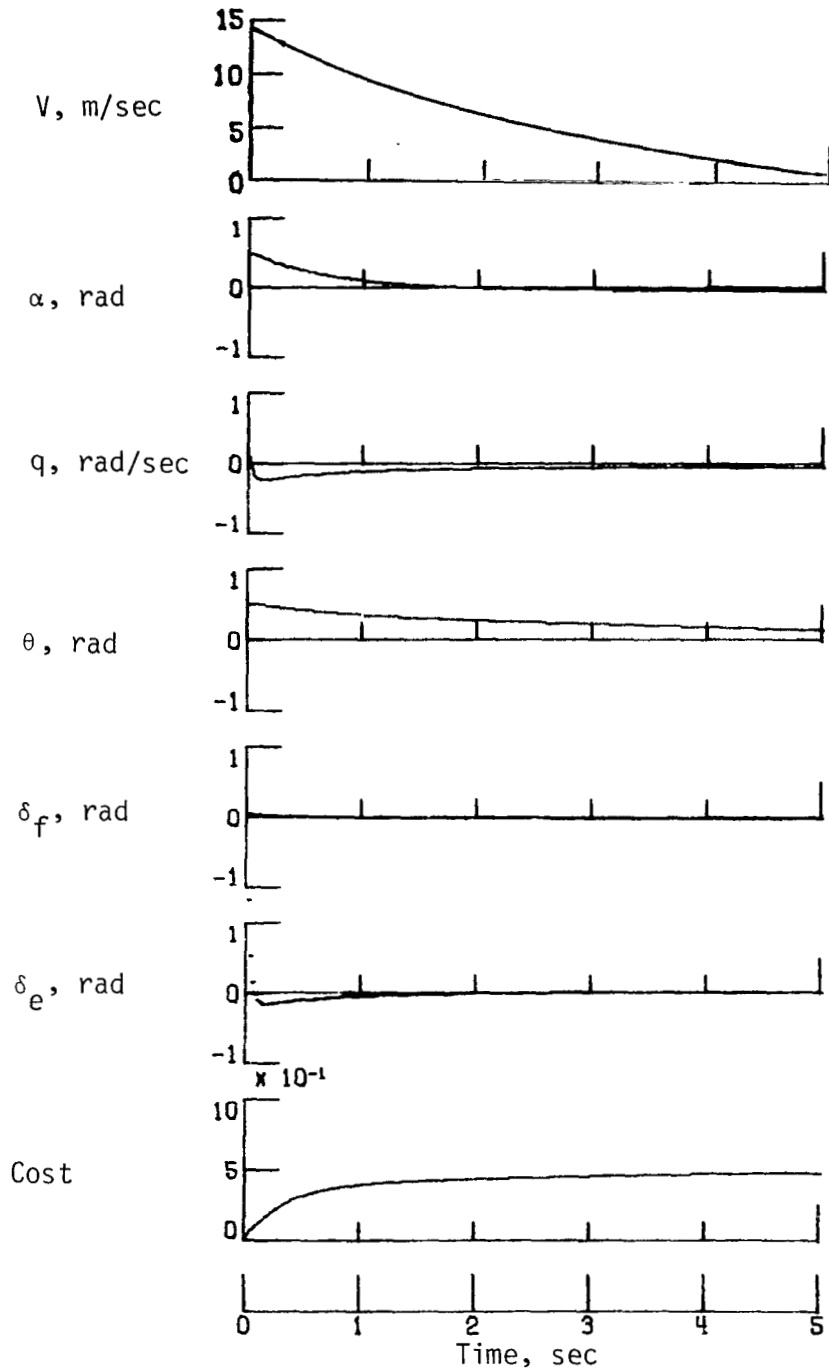

Figure 5.- Optimal response of airplane with 0.02 uniform sampling.

1. Report No. NASA TP-1743		2. Government Accession No.		3. Recipient's Catalog No.	
4. Title and Subtitle OPTIMAL REGULATION IN SYSTEMS WITH STOCHASTIC TIME SAMPLING				5. Report Date November 1980	
				6. Performing Organization Code 506-53-63-04	
7. Author(s) Raymond C. Montgomery and Peter S. Lee				8. Performing Organization Report No. L-13507	
				10. Work Unit No.	
9. Performing Organization Name and Address NASA Langley Research Center Hampton, VA 23665				11. Contract or Grant No.	
				13. Type of Report and Period Covered Technical Paper	
12. Sponsoring Agency Name and Address National Aeronautics and Space Administration Washington, DC 20546				14. Sponsoring Agency Code	
15. Supplementary Notes Raymond C. Montgomery: Langley Research Center. Peter S. Lee: NRC-NASA Resident Research Associate, now at Charles Stark Draper Laboratories, Cambridge, Massachusetts.					
16. Abstract <p>An optimal control theory is presented that accounts for stochastic and variable time sampling in a distributed microprocessor-based flight control system. The theory is developed by using a linear process model for the airplane dynamics and the information distribution process is modeled as a variable time increment process where, at the time that information is supplied to the control effectors, the control effectors know the time of the next information update only in a stochastic sense. An optimal control problem is formulated and solved for the control law that minimizes the expected value of a quadratic cost function. An example is presented where the theory is applied to the control of the longitudinal motions of the F-8 DFBW airplane. Theoretical and simulation results indicate that, for the example problem, the optimal cost obtained with a variable time increment Markov information update process where the control effectors know only the past information update intervals and the Markov transition mechanism is almost identical to that obtained with a known and uniform information update interval.</p>					
17. Key Words (Suggested by Author(s)) Optimal control Sampled data Stochastic control Nonuniform sampling Optimal regulator			18. Distribution Statement Unclassified - Unlimited Subject Category 66		
19. Security Classif. (of this report) Unclassified	20. Security Classif. (of this page) Unclassified	21. No. of Pages 26	22. Price A03		

National Aeronautics and
Space Administration

Washington, D.C.
20546

Official Business

Penalty for Private Use, \$300

THIRD-CLASS BULK RATE

Postage and Fees Paid
National Aeronautics and
Space Administration
NASA-451



6 1 1U,G, 111780 S00903DS
DEPT OF THE AIR FORCE
AF WEAPONS LABORATORY
ATTN: TECHNICAL LIBRARY (SUL)
KIRTLAND AFB NM 87117

NASA

POSTMASTER: If Undeliverable (Section 158
Postal Manual) Do Not Return
