

GENERATIONS OF ORTHOGONAL SURFACE COORDINATES*

F. G. Blottner and J. B. Moreno
 Sandia National Laboratories†
 Albuquerque, NM 87185

An orthogonal surface-oriented coordinate system has been developed for three-dimensional flows where the computational domain normal to the surface is small. With this restriction the coordinate system requires orthogonality only at the body surface. The coordinate system is as follows: one coordinate measures distance normal to the surface while the other two coordinates are defined by an orthogonal mesh on the surface. One coordinate is formed by the intersection of the body surface and the meridional planes as illustrated in Figure 1 and gives the $\theta = \text{constant}$ lines. The other coordinate ξ , which is nondimensionalized with a characteristic length of the body geometry, measures the distance along the body surface when $\theta = 0$. This coordinate system has been utilized in boundary layer flows^{1,2} and for the hypersonic viscous shock-layer problem.³

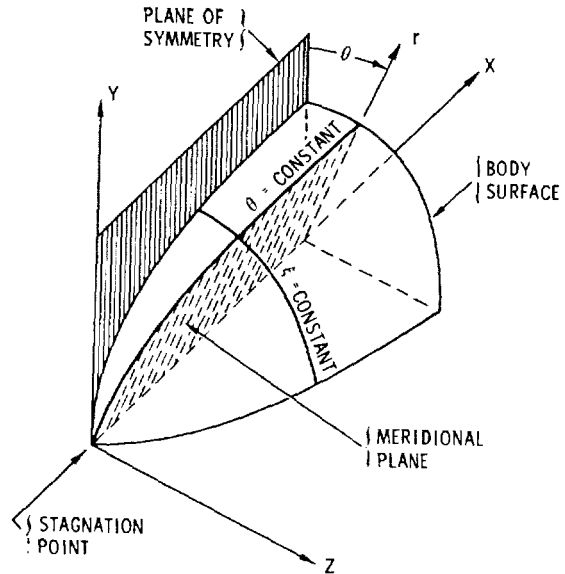

Figure 1. Surface Coordinate System.

Two methods have been developed for generating the surface coordinates. The first method uses the orthogonal condition in finite-difference form to determine the surface coordinates with the metric coefficients and curvature of the coordinate lines calculated numerically. The second method obtains analytical expressions for the metric coefficients and for the curvature of the coordinate lines. Both methods assume the body surface is defined in terms of a cylindrical coordinate system where $r = r(x, \theta)$. The surface inclinations ϕ_1 and ϕ_2 as illustrated in Figure 2 are determined from

$$\tan \phi_1 = \left(\frac{\partial r}{\partial x} \right)_\theta \quad \text{and} \quad r \tan \phi_2 = - \left(\frac{\partial r}{\partial \theta} \right)_x$$

and are known quantities.

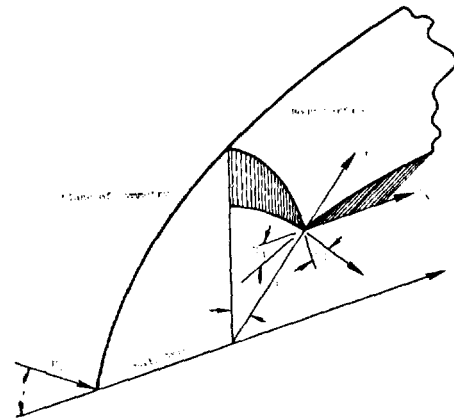

Figure 2. Angles ϕ_1 and ϕ_2 Defined in the Cylindrical Coordinate System.

* This work was supported by the U. S. Department of Energy under contract DE-AC04-76-DP00789.

† A U. S. Department of Energy Facility.

ORIGINAL PAGE IS
 OF POOR QUALITY

In the numerical method,^{1,2} the orthogonal condition for the surface coordinates results in the relation

$$dx = \lambda d\theta \quad (\text{along } \xi = \text{constant})$$

where

$$\lambda = r \tan \phi_1 \tan \phi_2 / (1 + \tan^2 \phi_1)$$

The equation of the surface provides the relation

$$dr = \tan \phi_1 dx - r \tan \phi_2 d\theta$$

The surface coordinate ξ is determined numerically from the foregoing equations by assuming a value of $d\theta$ and marching away from $\theta = 0$ to determine the values of x and r . In addition the metric coefficients are determined numerically from

$$h_\xi = ds/d\xi$$

$$h_\omega = dt/d\omega$$

where

$$\omega = \theta/2\pi$$

$$ds^2 = dx^2 + dr^2$$

$$dt^2 = ds^2 + r^2 d\theta^2$$

The curvature of the coordinate lines is determined from

$$K_\xi = \frac{1}{h_\xi h_\omega} \frac{\partial h_\xi}{\partial \omega} \quad \text{for } \omega = \text{constant}$$

$$K_\omega = \frac{1}{h_\xi h_\omega} \frac{\partial h_\omega}{\partial \xi} \quad \text{for } \xi = \text{constant}$$

with the derivatives replaced with midpoint difference relations.

In the second method³, an analytical expression is developed for h_ω as follows:

$$h_\omega = 2\pi r (1 + \cos^2 \phi_1 \tan^2 \phi_2)^{1/2}$$

A differential equation results for the other metric coefficient as follows:

$$\frac{1}{h_\xi} \frac{dh_\xi}{d\omega} = 2\pi r \cos^2 \phi_1 \tan \phi_2 \left(\frac{\partial \phi_1}{\partial x} \right)_\theta$$

This equation is integrated along $\xi = \text{constant}$ lines on the surface from the initial condition $h_\xi = 1$ at $\theta = 0$. The substitution of foregoing equations into the equations for K_ξ and K_ω give analytical expressions for the curvature of the coordinate lines. In evaluating these relations, the variations of x and θ along the $\xi = \text{constant}$ coordinate must be known.

A sphere at angle of attack as shown in Figure 3 is used to illustrate the computation of the surface coordinates with both methods. The surface coordinates on the sphere as viewed from the side are illustrated in Figure 4. The $\xi = \text{constant}$ lines result from planes intersecting the sphere with these planes passing through the line which is normal to the plane of symmetry and is located at

$$x/a = \sqrt{1 - (b/a)^2}$$

$$y/a = (x/a)^2 / (b/a)$$

The metric coefficients for this coordinate system are given in Figures 5 and 6 with good agreement between the two methods. The curvature of the coordinate lines is given in Figures 7 and 8. It is noteworthy that K_ξ is independent of ξ . The differences evidenced in Figure 8 can be partially attributed to the numerical evaluation of K_ω being at one-half mesh space locations away from the ξ indicated.

The numerical method of generating the orthogonal surface coordinates has been applied to ellipsoids, paraboloids and elliptic-paraboloids. The coordinates on an ellipsoid are illustrated in Figure 9. The second method or analytical approach has only been developed for the sphere.

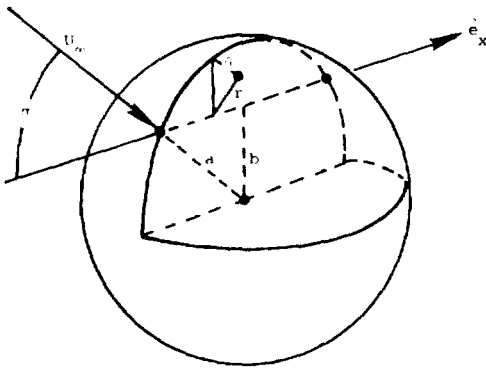
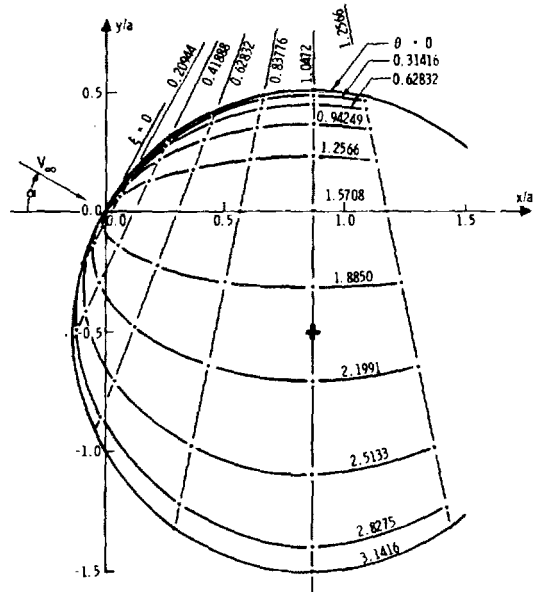

Figure 3. Cylindrical Coordinate System for "Sphere at Angle of Attack".



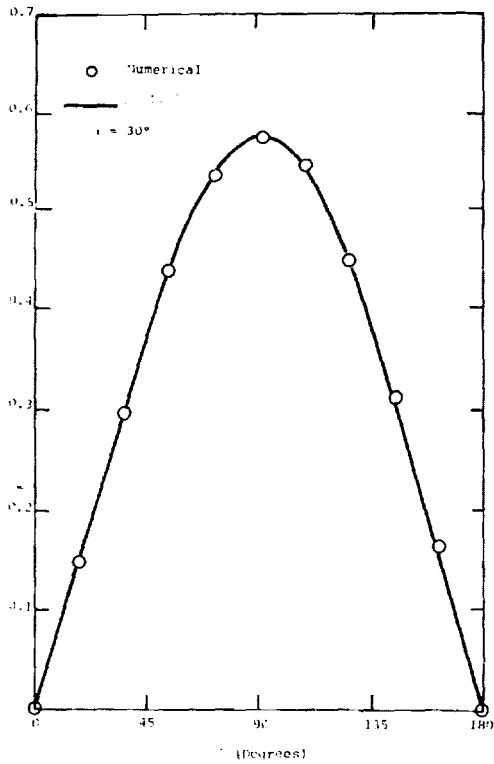

Figure 7. Geodesic Curvature of Lines of Constant θ .

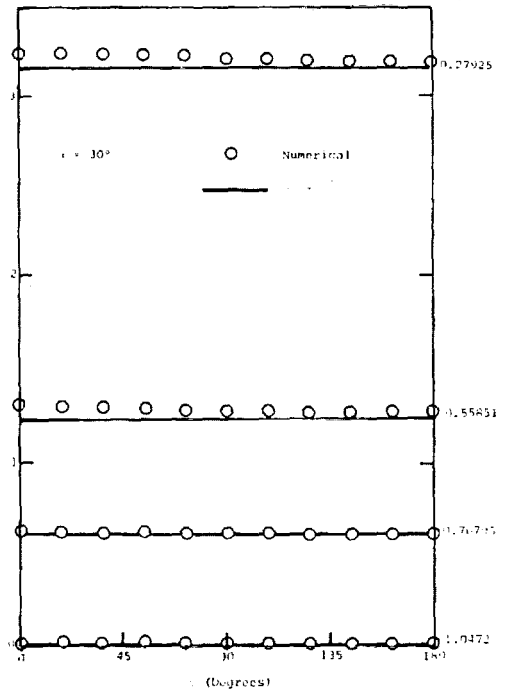

Figure 8. Geodesic Curvature of Lines of Constant ξ .

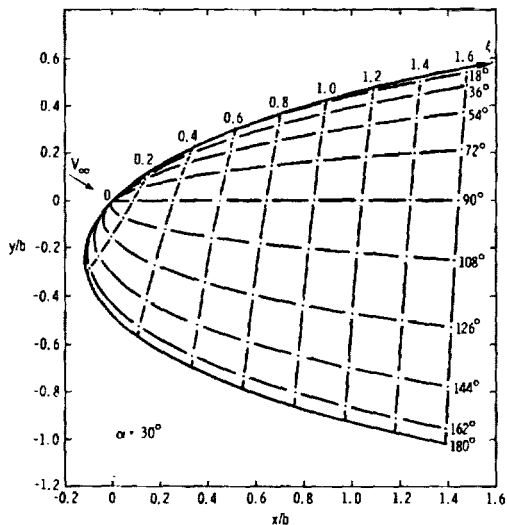

Figure 9. Surface Coordinates on Ellipsoid ($b/a = 1/4$)

References:

1. F. G. Blottner and Molly A. Ellis, "Finite-Difference Solution of the Incompressible Three-Dimensional Boundary Layer Equations for a Blunt Body," Computers and Fluids, Vol. 1, pp 133-158 (1973).
2. F. G. Blottner and Molly A. Ellis, "Three-Dimensional, Incompressible Boundary Layer on Blunt Bodies. Part I: Analysis and Results," Sandia Laboratories Research Report SLA-73-0366, April 1973.
3. J. B. Moreno, "Formulation of the Three-Dimensional Hypersonic Viscous Shock-Layer Problem Part I: Governing Equations and Geometrical Formulas," Sandia Laboratories Research Report SLA-73-0030.