

SPACELAB ENERGETIC ION MASS SPECTROMETER

<u>Principal Investigator:</u>	<u>Organization</u>	<u>Telephone</u>
B.A. Whalen	Herzberg Institute of Astrophysics National Research Council of Canada 100 Sussex Drive Ottawa, Ontario K1A 0R6 Canada	613-992-2734 Telex: 053-3715

Co-Investigators:

I.B. McDiarmid	Herzberg Institute of Astrophysics	613-992-7884
J.R. Burrows	National Research Council of Canada	613-992-2734
R.D. Sharp	Space Sciences Laboratory	Ext. 45479
R.G. Johnson	Department 52-12, Bldg. 205	Ext. 45508
E.G. Shelley	Lockheed Palo Alto Research Lab. 3251 Hanover Street Palo Alto, California 94304 U.S.A. Telephone: (415) 493-4411	Ext. 45508

INVESTIGATION SUMMARY

Energetic Ion Mass Spectrometer

A summary of the proposed energetic ion mass composition experiments for the Spacelab missions is presented in the following. The objectives of the experiments are: 1) to investigate the source region or regions for the energetic ion population in the magnetosphere; 2) to investigate ion energization, transport and loss mechanisms; 3) to detect the minor constituents of the ion population; and 4) to perform active tracer experiments. The instrument proposed for the measurements covers the energy range from thermal energies ($\sim 1/10$ eV) to 40 keV and is capable of resolving ions with rigidities up to 24.5 MV/c ($B\rho = 8.2 \times 10^4$ gauss cm) with a mass resolution $\Delta m/m = 0.1$. The geometric factor is large enough to measure the anticipated fluxes of minor ion species (e.g., O^{6+} , He_3^{++} , He_3^+ if of solar wind origin and He_4^+ , N^+ , N_2^+ , Ne^+ , Fe^+ if of ionospheric origin) in the energetic ion precipitation and will also be used to measure the more rare constituents of the ionospheric plasma.

The instrument proposed for the mission is composed of an electrostatic analyzer followed by a magnetic spectrometer and simultaneously measures the energy per unit charge (E/Q) and mass per unit charge (m/Q) of the ion species. This device is similar in principle to ones used by the NRC group for sounding rocket experiments, but has been scaled up to give a larger geometric factor. An electromagnet is used for momentum analysis to extend the operational energy range over a much wider domain than possible with the permanent magnets used in previous space flights. Retarding potential analysis followed by preacceleration has been added before the cylindrical plate electrostatic analyzer to extend the energy range to thermal energies and to increase the geometric factor for low energy ions. This feature is identical to that used by the Lockheed group on their ISEE and Dynamics Explorer satellite instruments.

The sensitivity and mass resolution capabilities of this instrument exceed by orders of magnitude any previously flown instruments since it is only the large weight carrying capability of the Shuttle which makes this instrument feasible for space experiments. In previous spacecraft experiments the momentum analysis performed by the magnetic field portion of the instrument was compromised by the weight and, to a lesser extent, the power available for any one instrument. This implied that the mass resolution and geometric factor for high rigidity particles was seriously degraded, making high resolution and high sensitivity mass composition measurements of keV to tens of keV heavy ions impossible. The Spacelab mission presents the first opportunity to make such measurements in the region of momentum space which is so important to the understanding of basic magnetospheric processes.

It is anticipated that results from this program will increase our understanding of processes involved in the injection, energization, transport and loss of magnetospheric ions.

1. SCIENTIFIC OBJECTIVES

Mass composition measurements of ambient magnetospheric ions have recently given new insight into magnetospheric processes. We propose to expand and improve on these measurements as well as to use the direct detection of ion tracer releases to improve our understanding of these mechanisms. The major objectives for this mission are outlined below.

a) Energetic Ion Source Regions

Ion mass composition measurements have been made in the past to determine the source regions for energetic magnetospheric ions. The two possible source regions, the solar wind and the ionosphere, have significantly different charge states and minor ion species composition. The dominant ion species in the solar wind are H^+ and He_4^{++} . The next most abundant species is three to four orders of magnitude down in intensity from H^+ . The ionospheric composition at low altitudes is both variable and strongly dependent on magnetic latitude. At latitudes below about 60° , the composition is dominated by H^+ and He_4^+ at altitudes above about 1000 km. At latitudes above about 60° , verticle profile data on the ionospheric composition are limited, but the dominant ion from the F-region peak up to altitudes of about 3000 km is often O^+ . The minor ionospheric ion constituents at high altitudes are not well known; indeed, one of the objectives of this program will be to measure these ions. Recent measurements indicate that Fe^+ ions are sufficiently abundant at ionospheric altitudes to be detectable in the energetic population, assuming an ionospheric source.

Mass composition observations indicative of both solar wind origin and ionospheric origin have been reported in the literature. However, the relative contributions of the two source regions to the hot magnetospheric plasma is uncertain at this time and remains the subject of considerable scientific interest. A major deficiency of the previous measurements has been the lack of adequate sensitivity to observe routinely the minor solar wind constituents which have entered the magnetosphere. One of the goals of this proposal is to utilize the greatly increased sensitivity to expand these investigations and to extend them into as yet unexplored mass and energy regions.

Although the possibility of detecting energetic heavy ion species such as isotopes of Argon, Krypton and Xenon is remote (using the sensor proposed here and assuming normal solar and atmospheric abundances), the cosmological significance of these measurements relating to the earth's accretion rate is important enough to dedicate some time to a search for these elements in the precipitation. A natural evolution of the instrument described here would involve an increase in the instrument geometric factor, and therefore size and weight, to make the detection of these species feasible. A geometric factor increase of one order of magnitude should be adequate and would imply roughly a factor of ten increase

in instrument (magnet) weight. The final design of the scaled-up instrument would depend on results from the first generation experiment.

b) Ion Energization Mechanisms

Several energization mechanisms for solar wind ions appear in the literature and these processes are sensitive to the m/Q of the ion being accelerated. The limited range in energy, mass and rigidity of ions detected until now make conclusive comparisons between theory and observation difficult. The detection of O^+ and He^+ ions in the magnetosphere have added an unexpected complexity to magnetospheric processes. These data indicate that the ionosphere is also an important source for energetic ions. Several theories have been presented which predict the energization of ionospheric ions, the energy source being either the ring current particles or electrostatic acceleration associated with auroral electron energization processes. The relative importance of these energization mechanisms remains uncertain.

The simultaneous measurement of energy spectra of several ions, particularly ones widely spaced in m/Q and rigidity, can be used to test the validity of these mechanisms. To this end the spectrometer described in the following has a greatly increased sensitivity and will have sufficient mass resolution, for high rigidity ions, to make the necessary spectral measurements of the heavy ion population.

c) Field Line Tracing

Naturally occurring heavy ions serve as good tracers of convective electric fields. The heavy ion composition can be used to identify a flux tube since at low energies all heavy ions will remain fixed to a particular field line which can then be identified at some later time by its composition. Using this method of identification, convection of field lines through the magnetosphere may be followed.

For example, assuming a solar wind injection, coordinated solar wind and low altitude observations will allow one to observe the regions and times for solar wind entry into the magnetosphere as a function of ion mass. Similarly, with an ionospheric injection event various ion clouds may be observed as a function of latitude and local time as they are convected and energized in the magnetosphere. As will be discussed later, observations of energetic ions at low altitudes can be significantly perturbed by charge exchange effects and such effects must be considered in modeling the events.

Active experiments involving the injection of easily identified heavy ions (e.g., lithium or barium) into the magnetosphere and solar wind are also planned. This technique offers a method of uniquely tagging field lines in a controlled fashion.

Direct detection of these ions at various times after injection will provide valuable information on both entry, if the release occurs in the solar wind, and energization mechanisms. Hence, a mass spectrometer capable of resolving the tracer ions from the ambient is required. This instrument should obviously have the largest possible geometric factor to maximize the detection probability and a high mass resolution to reduce the background due to the ambient. With such a device the motion and energization of tracer ions can be monitored directly.

As a first step toward successful tracer experiments, a survey of the ambient (background) ions with an instrument suitable for active tracer experiments must be undertaken. To date, this has not been done.

It should be noted that for low altitude injections the average tracer ion energy at injection, using shaped charge techniques, or the spacecraft orbital velocity, would be approximately 10 to 100 eV or of the same order as the ambient thermal plasma high energy tail. The spectrometer must therefore be capable of operating at low energies and, in fact, to complete the ambient ion survey, should be capable of analyzing to thermal (or ram) energies. This instrument has this capability although only the minor or trace ion constituents of the thermal plasma will be monitored. The dominant ion species would saturate the detector and should be measured using standard sensors.

d) Coordinated Investigations

Several spacecraft carrying ion mass spectrometers may be operated during the Spacelab flights (e.g., ISEE, DE, GEOS II, AMPTE, PIE II, etc.). Coordination of observation from these spacecraft along with simultaneous measurements from sounding rockets and ground-based (optical) facilities will be undertaken to investigate the spatial distributions of the various ion populations. These measurements will be conducted during the investigations discussed previously. If tracer ion releases are to be performed during the first mission, efforts will be made to coordinate the mass spectrometer observation periods with the release. Ion releases from the C.R.M. as well as SEPAC will be of particular interest here.

2. ORBIT CONSIDERATIONS

Charge exchange reactions can occur between precipitating ions and atmospheric constituents at low altitudes, thus changing the m/Q of the primary ion beam. Using the mean COSPAR international reference atmosphere, it can be shown that the unperturbed primary ion beam will be observed at 400 km altitude. However, since the atmospheric density may increase or decrease by an order of magnitude at these altitudes, depending on solar activity and latitude, the primary ion beam may or may not reach the sensor in its unperturbed charge state. Valuable observations, therefore, may be made

at 400 km. However, a preferred orbit would be a few atmospheric scale heights higher (i.e., 500-600 km).

It should be noted that contaminant gas surrounding the Spacelab may also cause significant charge exchange effects, hence a monitor of the local gas pressure is required to correct for periods of high ambient pressure associated with engine firings, etc., as well as to define the atmospheric conditions.

Clearly, if high latitude (auroral) data is to be obtained the orbit inclination should be at the maximum allowable. A polar orbiting spacecraft would be ideal; however, even a 57° inclination (launch from K.S.C.) would place the spacecraft in the auroral zone over northern Canada near local midnight.

3. INSTRUMENT DESCRIPTION

The instrument described in this section will be used as the basis for design trade-off studies during the PDP phase. The two groups involved in the study will contribute equally to this portion of the program. The Instrument Control and Data Handling system is to be developed by LMSC and the sensor is to be primarily NRC's responsibility.

As the basic design criteria we have required that the instrument have a mass resolution ($\Delta m/m$) of 0.1 for ions with rigidity (mv/Q) up to that of 20 keV O^+ ions, which is an mv/Q of 24.5 MV/c. Equivalently, in a magnetic field B , since $B\rho = mv/Q$ where ρ is the ion radius of curvature in the field, the maximum ion $B\rho$ will be 8.2×10^4 gauss cm. The instrument must also have an energy resolution $\Delta E/E$ of 0.1 and a geometric factor (G.F.) large enough to allow for detection of the minor constituents of the energetic ion population (G.F. $\sim 10^{-1}$ cm² sr). To perform the energy and mass analysis a combination of electrostatic and magnetic analysers shown in Figure 1 was chosen from among many possible designs considered. This design was selected to take advantage of the large area and near omnidirectional ion source (the magnetosphere). A focusing magnetic deflection system was selected to give both high sensitivity and low background.

a) Momentum Analyzer

To achieve a constant mass resolution independent of particle rigidity and a wide operational range, a magnetic analyzer formed with an electromagnet was chosen. This is a standard configuration for laboratory mass spectrometers. First order focusing using shaped pole pieces is employed to get the maximum geometric factor for a given poleface area (or magnet weight). The magnetic analyzer focuses a parallel beam of particles entering the curved pole face to a point which is at the centre of the channel electron multiplier array shown in Figure 1. Depending on the mass resolution and geometric factor requirements, the CEM elements may be operated either independently or various elements summed. This function is controlled by the instrument control and data handling

section. In the highest mass resolution mode only the centre elements are used while the end elements monitor the "background" rate.

One problem which must be considered in the selection of the sensing element is its response to contamination from Spacelab venting. Channel electron multipliers are less sensitive than other open-ended (discrete dynode) devices to the contaminants expected in the payload bay and thus are the preferred devices; however, we propose to study the response of the sensors to contaminant gases to ensure reliable operation. Ease of replacement of the electron multiplier after each flight is also important in the selection of the sensing elements.

Stray electric and magnetic fields may also interfere with some of the low energy measurements proposed. Ions with energies greater than a few hundred electron volts should, however, be relatively unaffected by the anticipated contaminant fields. To minimize this problem the spectrometer should be located in a region removed from insulating surfaces and high dc electric and magnetic fields.

Stray magnetic fields will also be produced by the electromagnet. A scale model of the analyzer was constructed and some initial tests conducted. The stray field was measured and, when scaled up to the flight unit, will be below the earth's field at a distance of ~ 3 m from the instrument with no magnetic shielding. Some shielding is required for proper operation of the instrument and more may be added as required to reduce the stray field.

A magnetic field strength of 10 k gauss (1 T) is needed in the gap to focus 20 keV O^+ ions. To estimate the peak power and current, the coil was assumed to be wound with #8 AWG wire. Three hundred and twenty turns at 25 amps will produce the 10 kg field. This implies a peak IR power dissipation of 200 Watts. The dissipation averaged over all operating modes and energies would be much lower (~ 50 W). Some savings in power can be made by going to more exotic windings; however, these figures serve as good estimates of the maximum power used by the electromagnet.

Other characteristics such as weight, inductance and time constant are listed in Figure 1. Although only rough estimates, the response time and mass of the system appear to be acceptable from an engineering viewpoint. The analogue control signals for the electromagnet power supply will originate in the instrument control section. The current supply circuit will operate on a feedback system, the primary field sensor being a magnetometer mounted in the gap. Using this type of feedback the coil will be driven to produce an overall response time of the electromagnet system of approximately 1/10 the magnet time constant (50 ms). Rapid changes in field require increased instantaneous power dissipation. To reduce the instantaneous power requirements to < 200 W a small capacitance storage ($\sim 10,000$ μ f

at 100 V) may be required for rapid increases in current. If all rapid changes are limited to decreasing field conditions no energy storage is required.

A drawing indicating the mounting and overall dimensions of the instrument package appears in Figure 2. During the PDP phase consideration will be given to mounting ICDH and some of the power supplies separate from the sensors.

b) Electrostatic Energy Analyzer

The energy analysis is performed using two systems, a retarding potential analyzer (R.P.A.) for low energy (0-50 eV) ions and a cylindrical plate electrostatic analyzer (C.P.E.A.) for high energy ions (less than 40 keV/Q). To retain an energy resolution $\Delta E/E$ of the order of 10% and still keep the deflection plate size to a minimum and the geometric factor at a maximum, as defined by the magnetic spectrometer pole face separation, a set of three concentric cylindrical plates will be used. The centre plate will be operated at roughly the mean of the potentials applied to the two outside plates. Collimators will be inserted between grid G_3 and the C.P.E.A. (see Figure 2) to produce the nearly parallel beam at the exit aperture required for the magnetic analyzer.

The C.P.E.A.-electromagnet system will be designed to be floated up to -3 kV. This option will be used to preaccelerate ions between the R.P.A. and the C.P.E.A., thereby increasing the detection efficiency and geometric factor for low energy ions.

In the high energy modes the R.P.A. is set to repel unwanted low energy ions. In the lowest energy mode the repeller grid (G_2) will be used to integral energy analyse the ions before preacceleration. This approach is identical to that used by the Lockheed group for the ISEE satellite mass spectrometer and is the proposed method for the DE mission. Positive ions entering the R.P.A. are analyzed in the 0 to 20 V range, accelerated by the 3 kV potential drop between G_2 and G_3 and momentum analyzed and detected in the negatively biased C.P.E.A.-magnetic spectrometer system. At this time the C.P.E.A. is set to analyze 3 keV/Q particles and is transparent to all low energy (<50 eV) ions. The R.P.A. will have typically 32 voltage steps and will be controlled by the instrument control logic and by the Spacelab computer.

In the mid-energy range (20-200 eV) two sub-modes can be selected. One uses 3 kV preacceleration and R.P.A. analysis to give pseudo-integral energy spectra, as in the low energy mode. The second mode uses no preacceleration and the C.P.E.A. to give differential energy spectra with $\Delta E/E = 0.1$.

In the high energy mode the R.P.A. is set to repel low energy (50 eV) ions and the C.P.E.A. is used for energy analysis. The preacceleration voltage can be set to either zero or 3 kV, depending on the requirements of the experiment. The preaccelera-

tion mode will be used to increase the effective geometric factor at the expense of energy resolution. With no preacceleration the C.P.E.A. plates are operated in a balanced configuration with the centre plate grounded and the two outside plates at voltages up to ± 6 kV. The plate voltages will be adjusted so that the centre trajectory energy will be the same in each half of the system.

The upper energy limit for heavy ions is set by the magnetic deflection system which was discussed previously. For ions with $m/Q < 16$ the magnetic analyzer is capable of focusing energies greater than 20 keV. Here the upper limit is set by the maximum voltage which may be applied to the electrostatic deflection plates. An upper limit near $E/Q = 40$ kV is estimated for these light ions.

All instrument operational modes are independently programmable via the Spacelab computer and instrument control section; however, a number of preprogrammed scanning routines will be available in the instrument. A typical example involves rapid energy scans from 20 keV to 2 keV at one selected mass. Here the energy would be stepped exponentially and the magnet current would track one particular mass species. The maximum scan rate here would be determined by the maximum allowable magnet dI/dt . The magnetic field current supply will be designed to complete one scan in 50 ms.

A second mode of operation calls for the scanning of a two-dimensional matrix in energy and momentum space. In this mode the magnetic field would remain fixed at a number of steps as the energies are scanned. The maximum scan rate is then defined by the C.P.E.A. high voltage supply rise time which will be 2 ms. As an example an 8×8 energy momentum array may be measured in ~ 200 ms. In many instances the actual dwell times on each element in these arrays will be determined by the requirement for statistical accuracy rather than the instrument capability.

A crude small scale model of the instrument was built and tested at the NRC laboratories. A scan of 2 keV beam emerging from the He^+ ion source is shown in Figure 3. This figure demonstrates some of the strengths of the system as well as the problems. We first note that the half width of the He^+ peak (0.04) is well within specification for single element detection at the focal point. The H^+ peak is due to contaminants in the source. We also note that the background is down by at least 10^{-4} of the peak which is essential for the mission.

The problem area lies in the low mass tail of the distribution which results mostly from inhomogeneities in the magnetic field. This problem will be corrected in the flight unit by magnetic field trimming. Small angle scattering may also be a problem and will be minimized by more careful baffling than present in the model.

Many applications for the instrument require pointing capability, therefore it is proposed that the instrument be mounted on a small, modest accuracy, instrument pointing system. The Spacelab computer will be used in conjunction with the output from the magnetometer sampling the ambient field to either monitor or actively point the mass spectrometer.

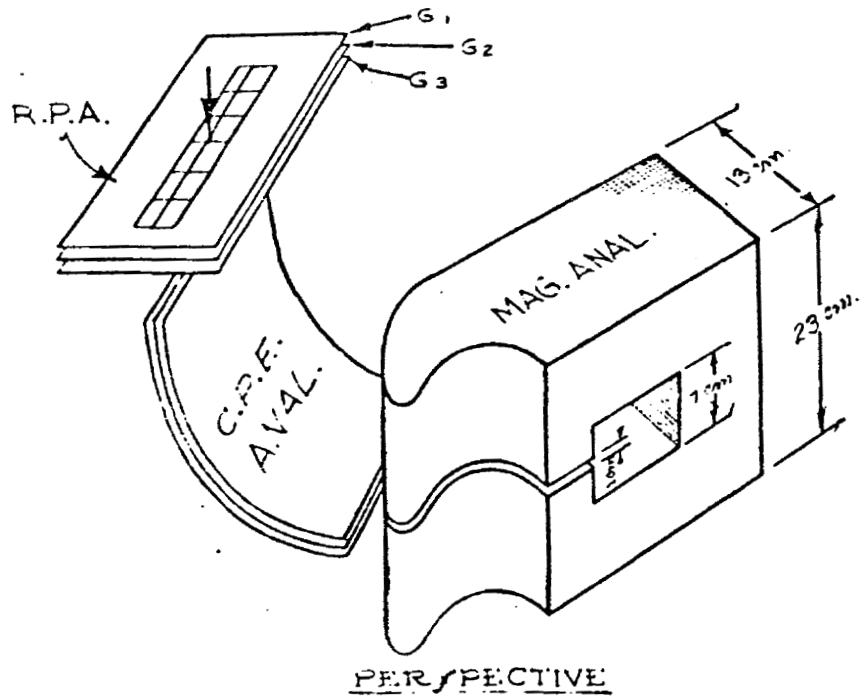

CHARACTERISTICS:

EFFECTIVE G.F. = 3.2×10^{-2} to $32 \times 10^{-1} \text{ cm}^2 \text{ sr}$
 MAX. PARTICLE RIGIDITY = $8.2 \times 10^4 \text{ gauss cm}$ (24.5 M/c)
 OR 320 keV H⁺
 20 keV O⁺

$$\frac{\Delta E}{E} = 0.1$$

$$\frac{\Delta M}{M} = 0.1$$

ANG. RES = 6°

WEIGHT = 60 kgms

POWER = 50 W (200 peak)

MAGNET INDUCTANCE = 0.16 h

MAGNET TIME CONST = 0.5 secs

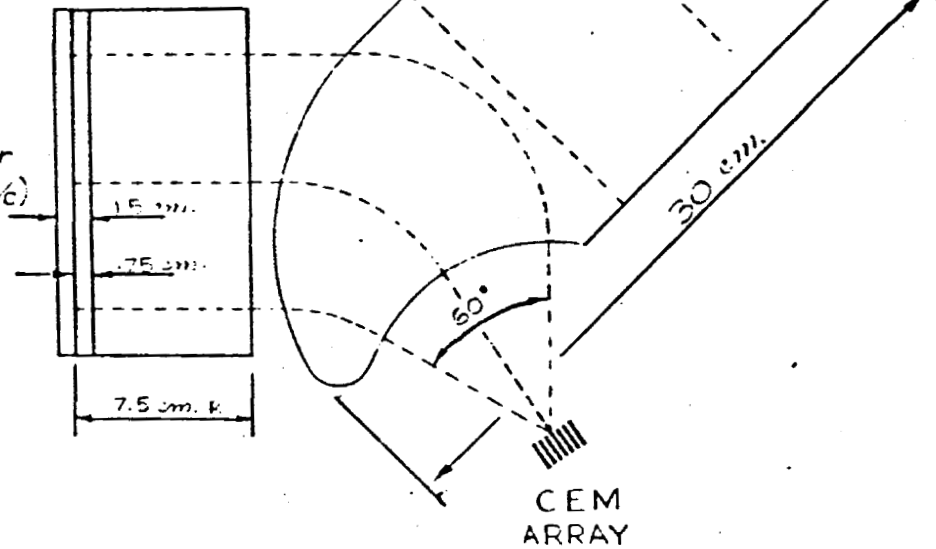

Figure 1

ION MASS SPECTROMETER

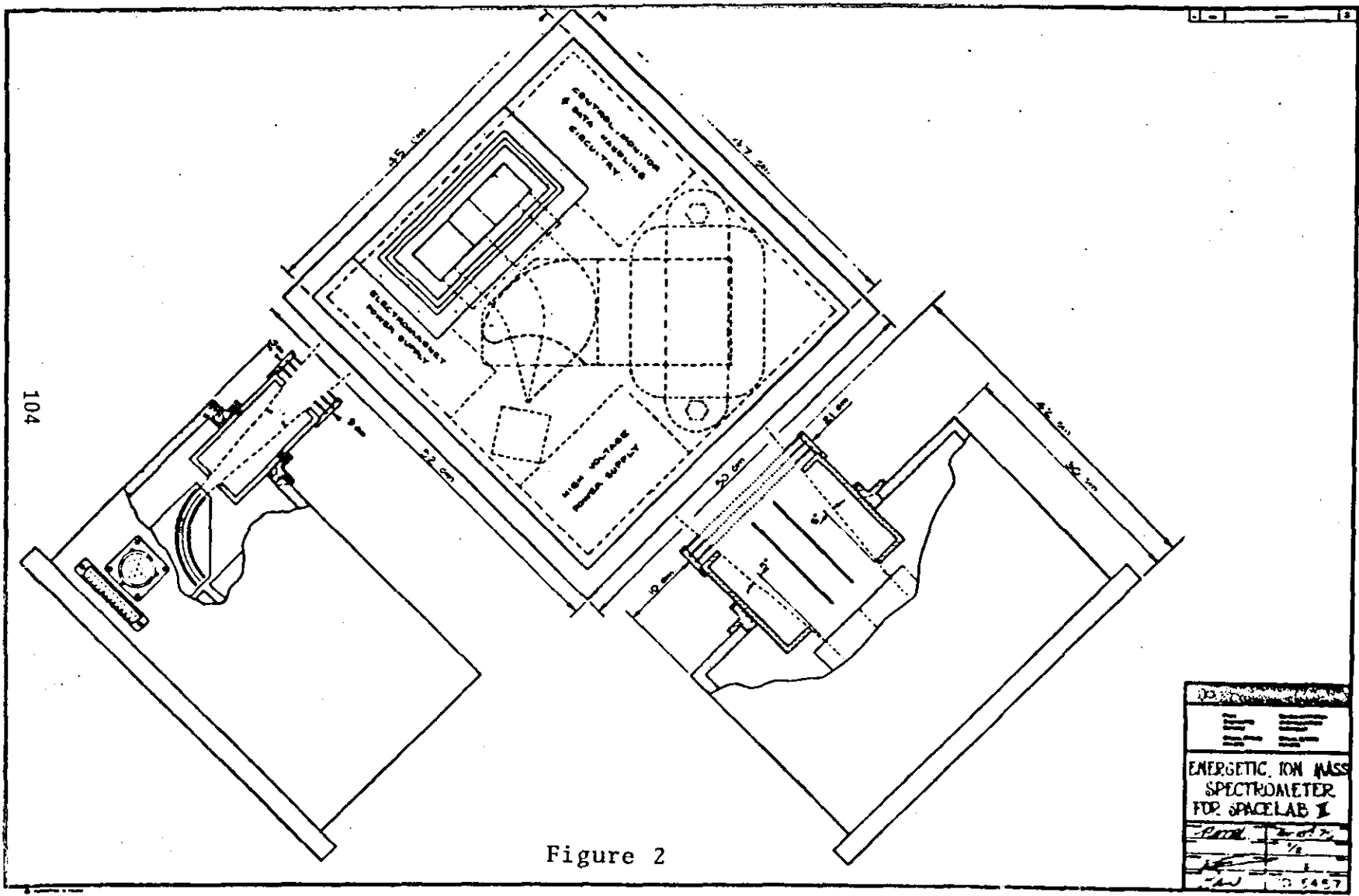

Figure 2

BEAM ENERGY - 2.0 KeV

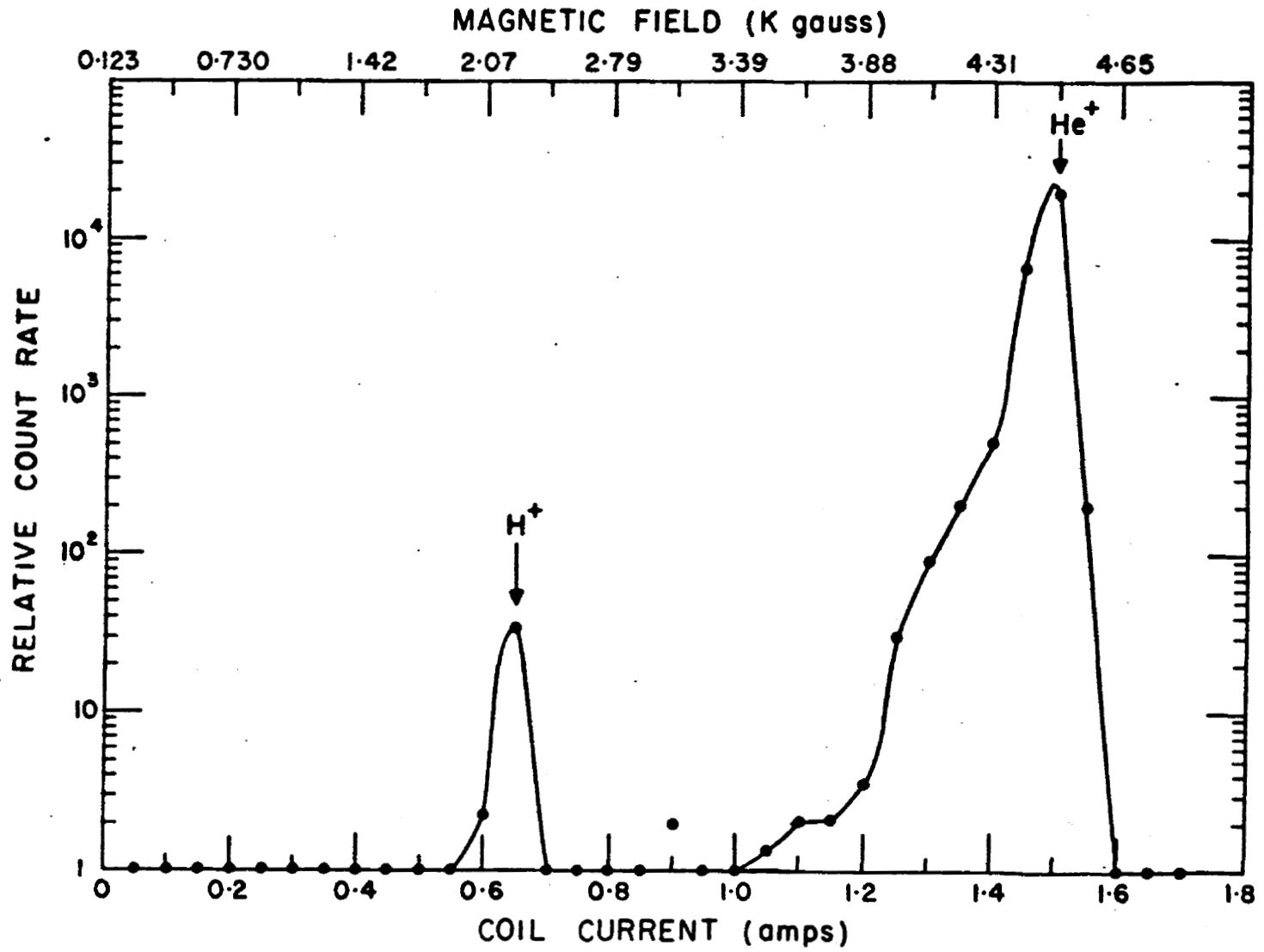

Figure 3