

**SOLAR POWER SATELLITE  
MICROWAVE POWER TRANSMISSION  
SYSTEM DESCRIPTION EXECUTIVE SUMMARY**

By Gordon Woodcock/Boeing

**BACKGROUND**

The idea of beaming baseload electric power from solar power satellites in space to utility receivers on Earth originated with experiments in microwave power beaming to small helicopters by W. C. "Bill" Brown of Raytheon in the 1960's. Peter Glaser's proposal for a Satellite Solar Power Station in 1968 included a conceptual system for microwave power beaming to deliver the solar energy to Earth.

The first NASA study of SPS was performed for the Lewis Research Center by A. D. Little, Grumman, Raytheon, and Spectrolab. That study, completed in 1972, selected 2450 MHz as the transmission frequency and determined that apertures on the order of 1 km at the satellite and 10 km at the ground receiver would provide efficient energy transfer. At that time it was estimated that 10,000 megawatts could be delivered through a single transmission link of this size. Subsequent studies, using a provisional intensity limit at Earth of 23 mw/cm<sup>2</sup>, somewhat less efficient dc-to-RF conversion efficiency, and more thorough thermal analyses, have reduced the single-link maximum power to 5000 megawatts.

The frequency selection of the original study was based on preliminary optimizations of energy transfer efficiency and cost. Higher frequencies lead to smaller apertures (and less power per link), but suffer additional atmosphere absorption and are expected to yield slightly lower dc-RF and RF-dc conversion efficiencies. Lower frequencies require larger apertures; the reference aperture is already uncomfortably large in the eyes of many reviewers. Present frequency allocations include industrial bands at 2450 and 5800 MHz. The present reference system has selected the lower of these two frequencies; preliminary analyses of the 5800 MHz option showed slightly higher costs if the same intensity limits were observed, but the 23 mw/cm<sup>2</sup> limit might well be raised at the higher frequency.

Frequency allocation for SPS was discussed at the 1979 WARC; no frequency was assigned but it was ruled that the U.S. could have such an assignment if the SPS is proven environmentally safe by further research.

**SYSTEM SIZING**

Selection of the microwave system power level is a problem of constrained optimization. The relevant constraints are illustrated in Figure 1. The most important factors are:

(1) Inefficiencies in conversion of dc electric power to microwave power result in waste heat that must be rejected to space by thermal radiation. The amount of heat that can be rejected per unit area is proportional to the fourth power of the absolute temperature of the heat rejection apparatus. Most of the heat appears at the RF amplifiers; the rejection capability is thus limited by the temperature limits of the amplifiers. This could be altered by refrigeration equipment (allowing heat to be rejected at temperatures above the amplifier limits) or by a large-scale heat transport system (allowing the heat rejection area to be larger than the transmitter aperture area). These alternatives have been avoided in the SPS reference systems in the interests of simplicity. For the reference system employing Klystron amplifiers, the heat rejection temperature is approximately 350C (=623K) permitting a thermal rejection capability of 4.5 kw/m<sup>2</sup> after emissivity and geometric factors are accounted. The net efficiency of the reference system is about 83% resulting in an RF power limit of about 22 kw/m<sup>2</sup>. It should be mentioned that the design of the reference system allows heat rejection only from the back side of the transmitter. Some of the alternate systems, notably solid-state transmitters, may be designed to reject heat from both sides. The solid-state system is, however, limited to heat

rejection temperatures on the order of 100C and is, therefore, limited to RF power densities roughly 1/4 those of the reference system.

(2) The maximum RF power intensity is in the ionosphere. This limit has presently been set at 23 mw/cm<sup>2</sup> based on theoretical considerations of ionosphere heating by the beam. The limit is quite uncertain and could be set higher or lower as a result of further research. (Preliminary results of heating tests suggest the possibility of a higher limit, but these results are not conclusive at present.) If the ionosphere limit can be raised, other factors, such as the tolerance of birds that may fly through the beam, may become important. This constraint sets the maximum power per unit area that can be derived from the receiving antenna. The average, of course, is less.

(3) The maximum allowable sidelobe level (RF intensity outside the receiving site controlled area) may affect aperture illumination factors. The transmitter aperture is nonuniformly illuminated to reduce sidelobes and improve link efficiency. Under certain assumptions one can show that a Gaussian amplitude taper is optimal. (For finite apertures the Gaussian must be truncated.) Other illumination tapers with similar shape yield nearly the same results. In any event it is necessary to quantize the actual illumination taper to conform to the various permitted subarray configurations (see below). An important tradeoff is the degree of truncation of the taper. The truncation is normally expressed as the ratio of center intensity to edge intensity. For example, a 10-db taper (the reference) indicates a factor of 10 reduction of intensity from center to edge. The greater the taper, the higher the link efficiency and the less the sidelobe intensity, as shown in Figure 2. The figure also shows the actual quantized taper as compared to the ideal truncated Gaussian.

One might think that the more taper the better, but there are adverse factors. Greater taper leads to (a) More beam spread as shown in Figure 3; (b) A smaller value of average-to-peak intensity at both the receiver and transmitter, as shown in Figure 4. Therefore, more taper leads to lower link power and larger apertures, both tending to increase system cost per kilowatt of generating capacity. These effects offset the cost reduction from increasing efficiency; there is an economically optimal illumination taper. For the reference system, the optimum is 10 db and the taper was selected on this basis.

The level of the first sidelobe that results from the reference taper and center beam intensity limit is about 0.1 mw/cm<sup>2</sup>. As this is below present microwave exposure limits in the U.S., the sidelobe level did not enter into the illumination taper selection. If standards below 0.1 mw/cm<sup>2</sup> are applied to SPS then the reference taper may have to be adjusted to comply. As an example, a taper of 17 db (assuming no change in center beam strength) will place the first sidelobe level at 0.01 mw/cm<sup>2</sup>. The system power output is reduced to about 4500 megawatts, the transmitter aperture increases to 1.2 km, and the ideal aperture-to-aperture efficiency increases from .965 to .990. As a result, the system cost per kilowatt is increased slightly.

The transmitter-receiver aperture product may be expressed as  $2\tau R\lambda$ , where  $\tau$  is a factor dependent on the transmitter illumination function, R is the range, and  $\lambda$  is the wavelength. As noted, the aperture-to-aperture beam efficiency is also dependent on the illumination function. For a given efficiency in the SPS range of interest, i.e. 0.8, the minimum value of  $\tau$  will result from a truncated Gaussian amplitude taper with the transmitter phase front focused at the receiver (for typical SPS transmitters, a planar wavefront gives essentially equivalent results). If one is willing to accept larger values of  $\tau$ , more flexibility is available for controlling the beam characteristics at the receiver. One may, for example, improve the average-to-peak intensity ratio as illustrated in Figure 5. This could reduce the rectenna land use by a factor on the order of 2, a very important prospect for improved ability to site rectennas in more densely populated areas. These beam-shaping features have not been incorporated in the present reference system, but merit serious consideration in the future.

Systems smaller than the reference can be designed. Figure 6 is a parametric map of variation in a unit cost function with link power and transmitter aperture. This particular map represents systems for which the maximum sidelobe intensity is constrained to 0.01 mw/cm<sup>2</sup> (the reference system is at 0.1) and the cost-optimal system is sized at about 4500 megawatts with a 1.2-km transmitter as discussed above. (The power figures on the chart are input power to the transmitter and should be multiplied by a link efficiency of about 60% to derive net output power on the ground.) Systems with power rating less than the reference incur a cost penalty that is modest down to a power level of about 2500 megawatts, and increases more rapidly below that level.

### TRANSMITTER ARRANGEMENT

The power transmitter is illustrated in Figure 7. It is a large planar phased array made up of subarrays mounted on a two-tier (primary and secondary) structure. Each of the 7220 subarrays includes from four to thirty-six klystron power amplifiers and associated control electronics. The quantized variation in the number of klystrons per subarray, and hence power density, provides an approximation to a 9.54 db, truncated Gaussian power illumination taper.

The subarrays are supported by the secondary structure, in turn supported by the primary structure. DC power from the solar array is fed to the subarrays through power processing and protective switch gear. About 15% of the power is processed to alternate voltages and regulated as necessary. The remainder is provided directly to the klystrons. All power is connected through interrupters and disconnect switches for fault isolation.

The reference phase distribution system distributes a coherent reference clock signal to all subarrays. This signal and the uplink (pilot) signal are phase conjugated at each klystron power amplifier to provide low-level RF drive signals of the correct phase. These signals are amplified to about 5 watts by solid-state preamplifiers and fed to each klystron; the klystron RF power output is approximately 70 kw each.

The antenna mechanical pointing includes star sensors and control moment gyros that aim the antenna toward its ground station to an accuracy of about one minute of arc. Computation is provided by the information management and control system; ground commands to correct residual aiming errors can be input through the communications system if necessary. Continuous desaturation of the CMG's is provided by a feedback loop that commands the antenna turntable drive. Low-pass filters and a compliant antenna mechanical suspension permit the CMG' to retain fine pointing control authority.

The antenna maintenance equipment includes crew provisions and mobility systems to support periodic removal and replacement of failed equipment.

The primary structure is a pentahedral truss made up of 1.5 meter tribeams fabricated in space by a beam machine. Feedstock for the beam machine is a graphite filamentary composite thermoplastic material shipped from Earth in roll and/or nested form. The beam elements are protected with thermal control and ultraviolet screen coatings and by selective multilayer insulation in the area where the transmitter head dissipation creates a thermal environment that would otherwise exceed the temperature capability of the material. Beam sections are terminated in centroidal fittings with mechanical attachments that include joint-slop takeup provisions to maximize structure rigidity.

The secondary structure provides a bridge on the MPTS primary structure and provides the base for mounting the transmitter subarrays, which are installed on a three point mount. The basic element is a 10.4 meter beam, 2.5 meters in depth, space fabricated from graphite composite

materials. The secondary structure is continuous around the perimeter of the antenna. In one direction the member spacing between rows is the width of one subarray and is the width of two subarrays in the orthogonal direction. Relationships between primary and secondary structures and subarrays are shown in Figure 8.

Each subarray includes 120 radiating waveguide "sticks" each 60 wavelengths in total length. The sticks geometry is selected so that the stick wavelength is twice the stick width, yielding a subarray 10.43 meters square. The arrangement of klystrons and RF power distribution waveguides is selected to minimize continuous stick length subject to the constraint that each stick be an integral number of wavelengths. Shorts within the sticks set the length of each radiating element. Pertinent discussions are given in the descriptive sketch. Minimizing stick length provides 3 advantages:

- o Reduced sensitivity to temperature
- o Greater slot offset, reducing scattering loss sensitivity to tolerances in slot offset
- o Reduced RF I<sup>2</sup>R losses

All of the subarray configurations are schematized in Figure 9. All geometries except the 4 x 4 employ a split klystron output to cut active stick length in half. This cannot be done for the 4 x 4 configuration because 60 is not evenly divisible by 8.

The subarray distribution and radiating waveguides are assumed fabricated from graphite/aluminum metal matrix composites. The structure members are a high-temperature graphite plastic-matrix composite. Solid-state components are mounted on the radiating waveguide assembly under multilayer insulation so that the radiating waveguide serves as a cold plate. In addition, thermal insulation is used to force the klystron heat rejection system to radiate only out the back face of the antenna, alleviating the thermal environment for the solid-state components.

The MPTS power distribution system provides power transmission, conditioning, control, and energy storage for all elements mounted on the antenna side of the rotary joint. The antenna is divided into 228 power control sectors, each of which provides power to approximately 440 Klystrons. The Klystrons require power at 9 different voltage levels. Two of the Klystrons' depressed collectors require the majority of the supplied power and are supplied directly from dedicated portions of the satellite power generation system. The rest of the Klystron supplied power and the power required for other power consuming equipment mounted on the power transmission structure is provided by DC/DC converters. Switch gear is provided for power control and fault protection. System disconnect switches are provided for equipment isolation for maintenance purposes.

Aluminum sheet conductors are used for power transmission from the interface subsystem to the power sector control substations and are routed along structural elements on the antenna primary structure farthest from the radiating waveguides. Round aluminum conductors provide power transmission from the substations to the antenna RF subarrays. Flexible connections are used to route power across the elevation joint between the antenna yoke and the antenna. Each power sector substation includes the required DC/DC converter, switchgear, disconnects, and energy storage. Figure 10 shows the circuit diagram.

The Power Transmission System Attitude Control System provides fine control of antenna mechanical aiming. Control Moment Gyros (CMG's) are used to generate torques required for this fine control. Control of the CMG's is accomplished using the signals derived from pointing errors determined from the phase control system. Rough pointing to acquire the phase control signal is accomplished using star scanners to control the CMG's.

The CMG's are located on the back side of the Primary Structure and are 12 in number for each transmitting antenna. A feedback loop from the Antenna Attitude Control System to the SPS mechanical rotary joint allows the rotary joint to apply torque to the antenna to continuously desaturate the antenna CMG's. This torque is supplied through a highly compliant mechanical joint so that the natural frequency of the antenna in its mechanical supports is below the control frequency bands for the CMG's controlling antenna attitude.

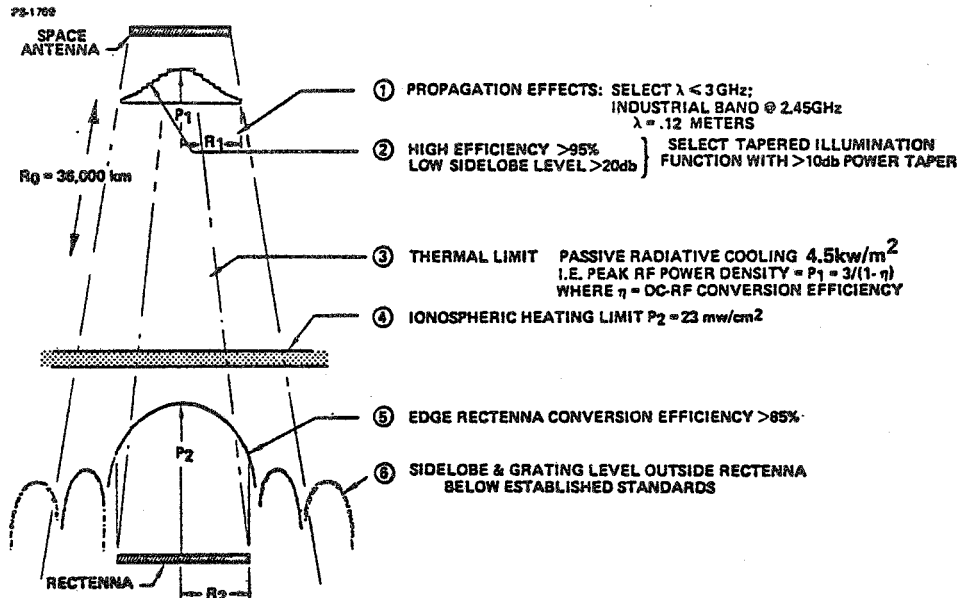

Figure 1: Design Constraints In Microwave Beam Link

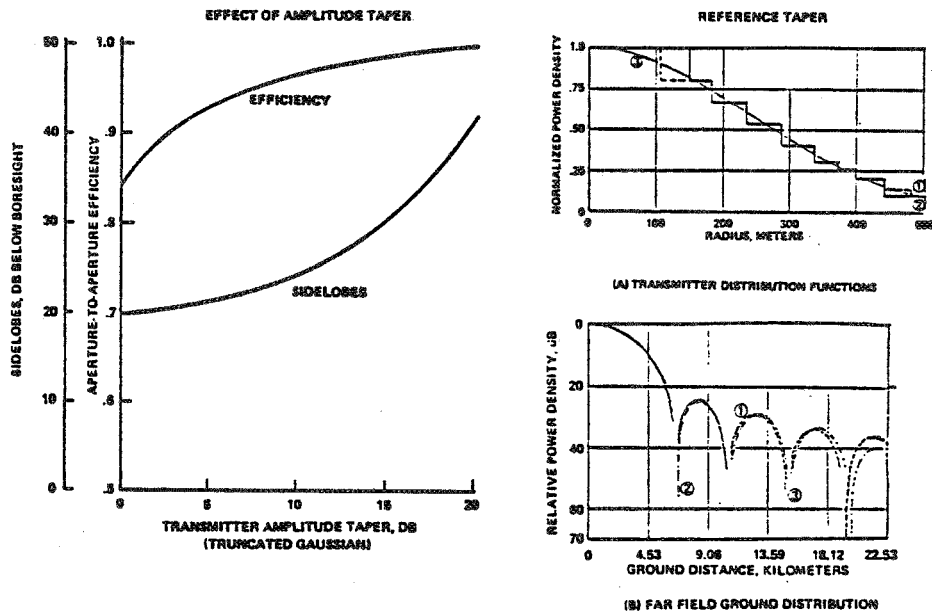

Figure 2: Power Transmitter Illumination Taper Factors

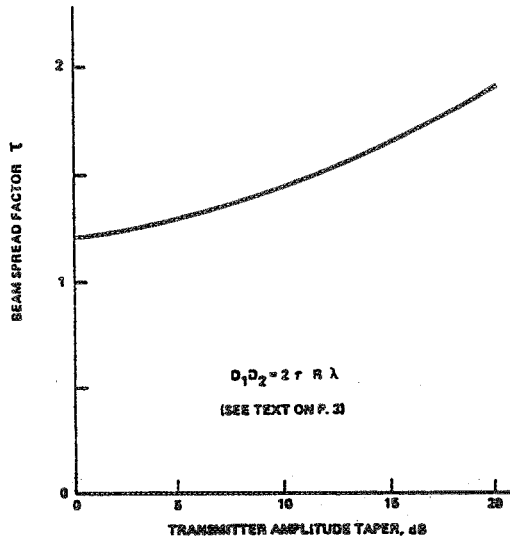

Figure 3: Beam Spreading

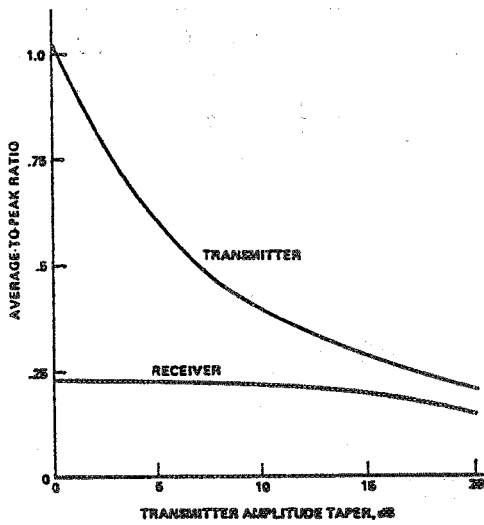

Figure 4: Intensity Ratios

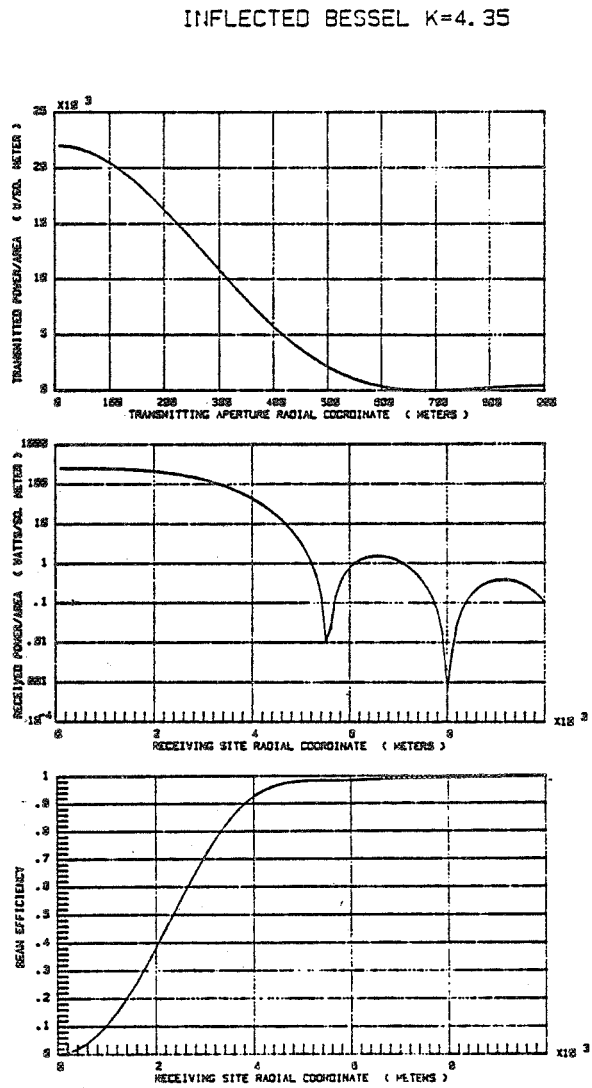

Figure 5: Use of Larger Aperture To Improve Average Ground Receiver Intensity

Figure 6. - Transmitter constraints determine minimum cost design point.

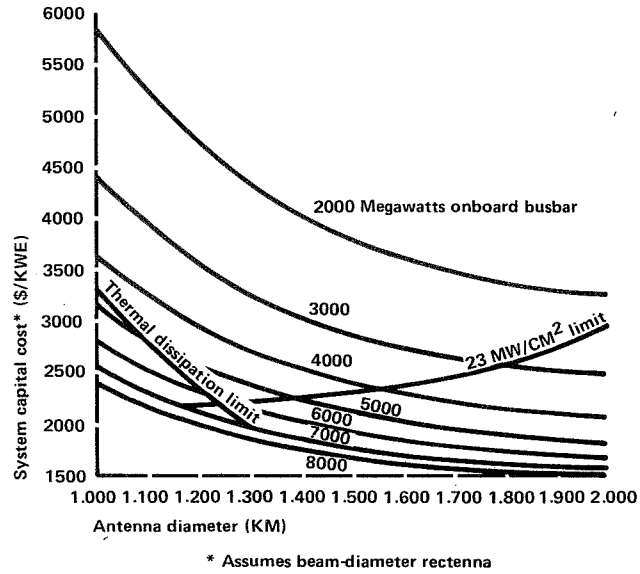
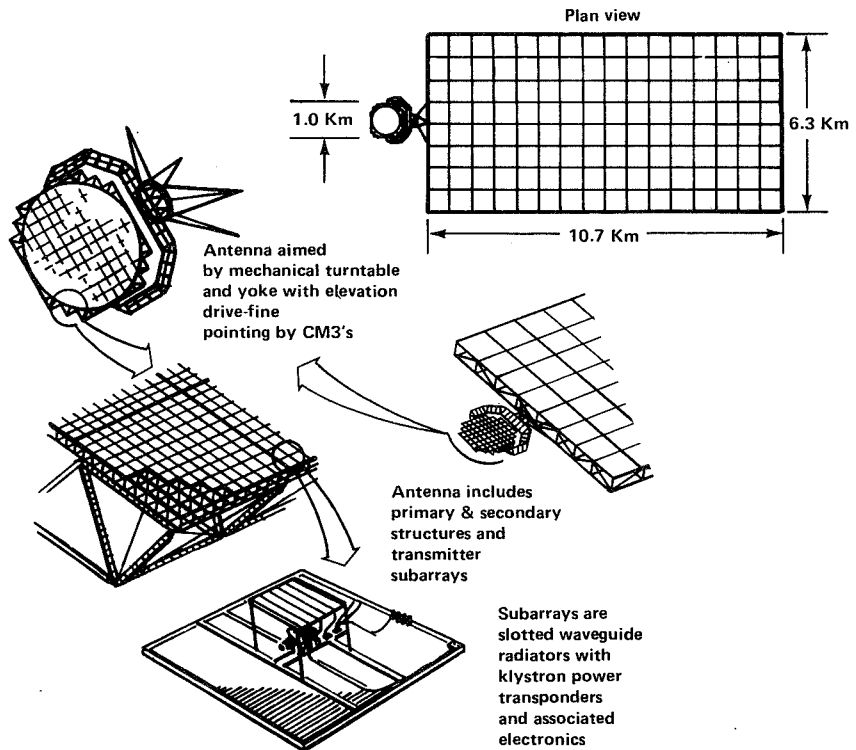
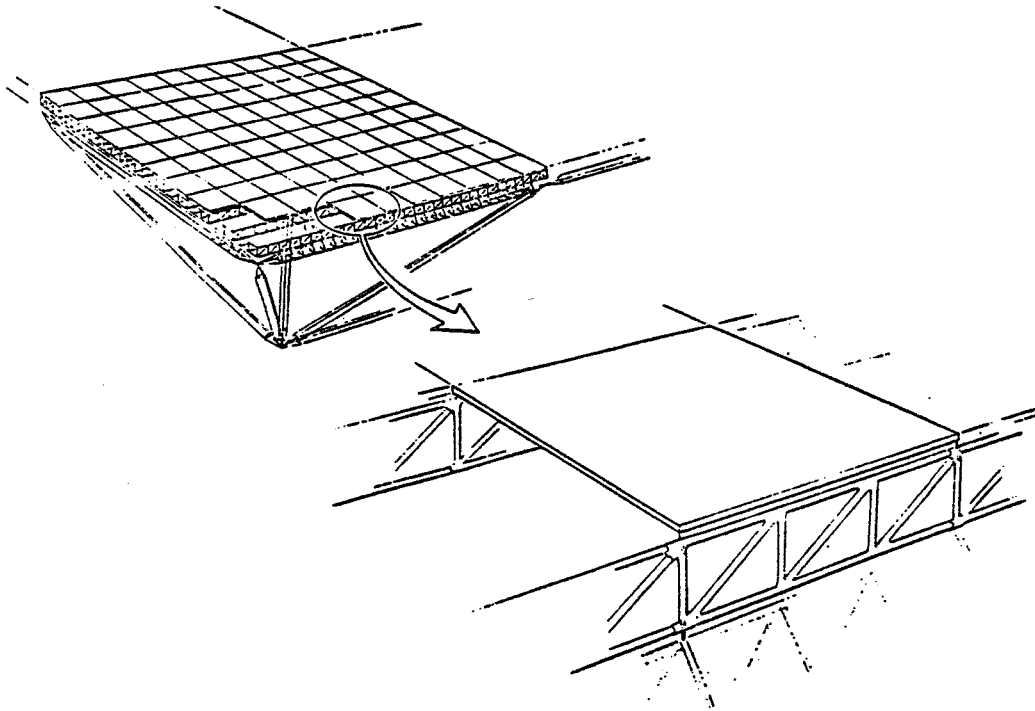

Figure 7. - Power transmitter.





**Figure 8 - Secondary Structure**



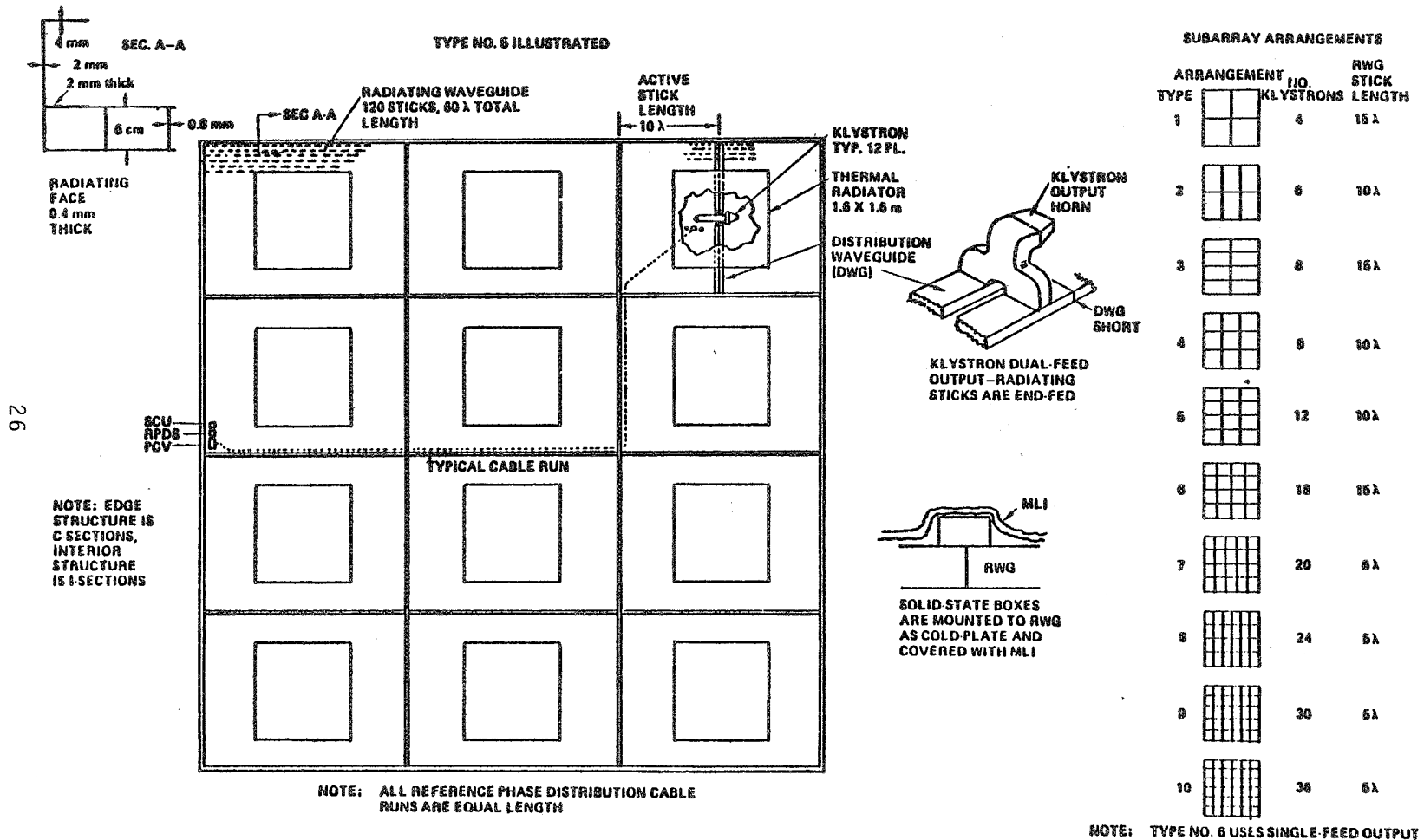

26

Figure 9: Transmitter Subarrays

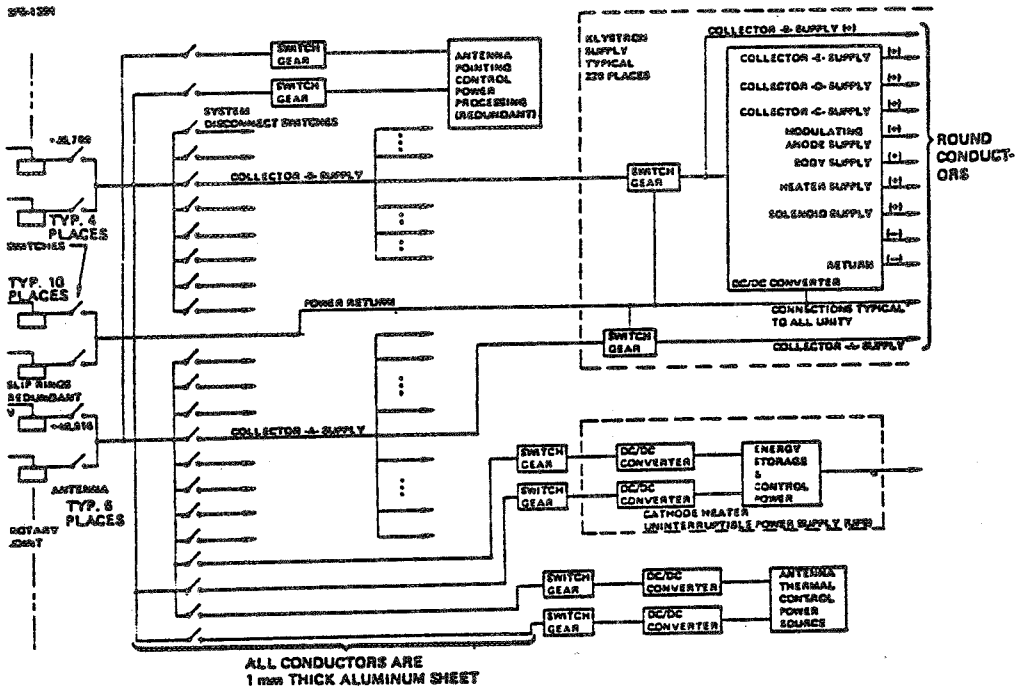

Figure 10 - Power Distribution