

OPERATIONAL CONSIDERATIONS IN UTILIZATION OF MICROWAVE

LANDING SYSTEM APPROACH AND LANDING GUIDANCE

William F. White and Leonard V. Clark
Langley Research Center

SUMMARY

Nearly five years of flight experience has been gained with the TCV B-737 using MLS guidance to fly curved, descending intercepts of final approaches as short as 0.8 km (0.44 n. miles). During that time the United States MLS has been adopted as the world standard, and development of operating performance standards and practices is under way. This paper briefly reviews the present characteristics of MLS equipment and summarizes TCV flight performance, then considers some possible uses of MLS to solve current noise abatement problems and the requirements for service area in light of TCV experience.

It is suggested that existing visual approach procedures could be improved by the use of MLS guidance, and that the experience and confidence necessary for air traffic controller and pilot acceptance of new MLS procedures could be gained in this manner. Examples are given using published approaches to San Francisco and two New York airports, as well as experimental curved approaches at Buenos Aires. For one of the approaches, a minimum coverage ($\pm 40^\circ$) system is inadequate. In another case, even the maximum coverage of $\pm 60^\circ$ is not sufficient unless the service region is skewed to provide asymmetric coverage.

MLS altitude is preferable to radio or barometric altitude at the lower levels for purposes of obstacle clearance, flying curved or segmented constant descent paths, and landing. However, the disagreement between MLS and barometric altitudes at upper levels during non-standard atmospheric conditions may create transition problems and a requirement for greater vertical separation between aircraft than is presently used.

Examples of need for a 360° azimuth function are given, but this option is still only in the conceptual stage. Some flight experience has been gained with experimental back azimuth and flare elevation systems, but there are still questions as to how both functions should be used.

Currently, most attention is directed towards the initial introduction of MLS in a manner most compatible with existing ILS practice. This is a desirable objective in order to minimize confusion during a period when MLS and ILS will be in simultaneous use. However, further effort is needed to establish practices and procedures by which the full capabilities of MLS can be utilized, and to insure that they do not conflict with conventional uses.

INTRODUCTION

In October, 1976 some operational aspects of initial experiments with the Microwave Landing System (MLS) were presented at the Aircraft Safety and Operating Problems Conference (reference 1). In the succeeding four years, considerable additional experience has been obtained with more difficult flight paths and using MLS ground equipment of varied capabilities at Buenos Aires, New York, Montreal and NAFEC (recently renamed FAATC). Also during that period the time reference scanning beam MLS has been adopted by ICAO as the new international standard landing system, and several national and international organizations are in the process of defining standards and practices for ground and airborne equipment. It therefore seems timely to review MLS characteristics in light of earlier operational requirements (e.g. reference 2), TCV flight experience, and present and expected operational procedures and problems.

This paper briefly summarizes the characteristics and performance of MLS equipment utilized by the TCV B-737. Several classes of MLS service and approach procedures are discussed in light of TCV experience. Since the early uses of MLS will involve procedures identical to ILS, most of this discussion is concerned with exploitation of MLS capabilities not possessed by ILS. Examples are given of how this could be done by using MLS to enhance the safety and utility of procedures presently in use for noise abatement. Finally, some areas which require definition of new procedures and conventions are indicated.

SYMBOLS AND ACRONYMS

AZ	Approach Azimuth
BAZ	Back Azimuth
CAT I	Category I Landing Minima {71 m (200 ft) decision height, 732 m (2400 ft) runway visual range}
CAT II	Category II Landing Minima {30.5 m (100 ft) decision height, 366 m (1200 ft) runway visual range}
CDI	Course Deviation Indicator
CMN	Control Motion Noise
CRI	Location identifier for Canarsie VORTAC
DME	Distance Measuring Equipment
DME-M	Precision Distance Measuring Equipment associated with MLS
DME-N	Standard Distance Measuring Equipment

EL	Approach Elevation
FAA	Federal Aviation Administration
FAATC	Federal Aviation Administration Technical Center
FAF	Final Approach Fix
GPIP	Glidepath Intercept Point
h	Height at which transition is made from approach elevation to flare elevation guidance
ICAO	International Civil Aviation Organization
IFR	Instrument Flight Rules
ILS	Instrument Landing System
JFK	John F. Kennedy International Airport; Location identifier for Kennedy VORTAC
LF	Low Frequency
LOM	Outer Compass Locator/Outer Marker
MLS	Microwave Landing System
MSL	Mean Sea Level
NAFEC	National Aviation Facilities Experimental Center
PDME	Precision Distance Measuring Equipment
PFE	Path Following Error
R	Radial
RNAV	Area Navigation
RWY	Runway
SFO	San Francisco International Airport; Location identifier for San Francisco VORTAC
STAR	Standard Terminal Arrival Route
T	time
TCV	Terminal Configured Vehicle

TD	Touchdown
VFR	Visual Flight Rules
VHF	Very High Frequency
VNAV	Area navigation with vertical guidance included
VOR	Very High Frequency Omnidirectional Range
VORTAC	Colocated VOR and military Tactical Air Navigation system providing both azimuth and range information
X_{TD}	Distance from runway threshold to aircraft MLS antenna at touchdown
α	Elevation angle
θ	Azimuth angle
σ	Standard deviation

MLS CHARACTERISTICS AND ACCURACY

Equipment

MLS Ground Equipment. Figure 1 shows the MLS installation colocated with ILS at Buenos Aires, Argentina, which the TCV B-737 used in the fall of 1977. The system illustrated used the Basic Narrow (aperture) equipment, with a proportional azimuth coverage of $\pm 40^\circ$. The currently favored practice for minimizing elevation signal multipath contamination involves centerline emphasis for the elevation antenna. That is, an antenna pattern similar to the one shown at the right side of figure 2 is used to concentrate power along the runway centerline, reducing reflections from buildings or other obstacles to the sides. With such an antenna, a typical MLS installation will provide the minimum lateral coverage indicated in figure 2. The required lateral coverage area is at least $\pm 40^\circ$ (not necessarily all proportional) measured from the MLS datum point, a point on the runway adjacent to the elevation antenna. However, it is readily seen from figures 1 and 2 that the azimuth coverage angle must actually be measured with respect to the azimuth antenna, located at a typical distance of 2 to 4 km (≈ 1 to 2 n. miles) from the datum point. The resulting strips of coverage on either side of the specified service area are important for MLS approaches on downwind or base legs near the airport.

An operationally significant region is the volume in which azimuth and DME signals are available, but not elevation. This information can be used for accurate area navigation in combination with barometric altitude. The volume appears to be insignificant in figure 2, but may actually extend over the entire coverage area for as much as half the coverage volume, since the current proposals (reference 3) specify a minimum azimuth coverage of 15° above the horizontal, but the minimum requirement for the elevation scanning beam is

only 7.5°. The subject of RNAV position updating with MLS and of MLS versus barometric altitudes will be discussed later.

One of the advantages of MLS is that the antenna patterns may be tailored to minimize radiation near the surface, thereby reducing multipath effects caused by reflections from the ground. However, this characteristic may have implications for the ability to test an MLS airborne installation on the ground prior to takeoff, since coverage is required only down to 2.4 m (8 ft) above a line of sight to the azimuth antenna. This may also be a factor to be considered in the use of MLS for guidance during landing and rollout phases, especially on humped runways.

Three range options are currently possible for MLS installations. The first would provide MLS angle guidance only and follow ILS practice by the use of marker beacons or other radio fixes to provide distance to touchdown information. The second option would provide conventional L-band DME, which has been designated DME-N. This could be substituted for marker information, as it is with ILS, and could be used with the MLS angle data to provide RNAV position data for the initial approach phase. Finally, precision range data can be provided by a modified L-band DME, designated DME-M. This information would be sufficiently accurate for use in autoland computations and in RNAV position updating where accurate flight path following might be critical.

MLS Airborne Equipment. The simplest MLS receiving equipment will probably be operationally indistinguishable from ILS. However, most receivers will at least have selectable azimuth and elevation reference angles and some sort of basic data display. The more sophisticated equipment, for use with airborne computers, will have digital angle data outputs and capability for decoding auxiliary data transmissions. A conventional DME may be used with either DME-N or DME-M ground stations but will not provide the accuracy required for flare and landing computations. A precision DME may also be used with either DME-N or DME-M ground equipment and will provide precision range data where DME-M is installed.

Airborne antennas will likely be a more critical item with MLS than with VHF systems and may restrict allowable maneuvers or procedures unless multiple antenna installations are used. Considerable analysis and experimentation has been conducted and sponsored by the Langley Research Center on antenna patterns and locations. Figure 3 shows the antenna locations which have been flight tested on the TCV B-737. Several of these have also been extensively studied analytically and by scale model measurements, and a technique has been verified for accurately predicting volumetric coverage of airborne antennas. The bottom front antenna is a location used only for experiments using the optional MLS flare subsystem at NAFEC (recently renamed FAATC), where it was desired to make measurements near the ground to test a multipath reduction processing technique for the FAA. This location is undesirable because it is more likely to provide degraded signals while operating on or near the runway, and interference from landing gear doors is experienced with omnidirectional antennas. The fin-mounted antenna provides good omnidirectional coverage but requires long cable runs and is subject to

pattern lobing due to reflections from the fuselage and wings.

The two remaining antennas can provide complete coverage for most normal maneuvers, as shown by the patterns in figure 4. Both are simple $\frac{1}{4}$ -wavelength stubs providing omnidirectional coverage in the plane tangent to the mounting surface. This results in the blind spots shown due to blockage by the fuselage in the principal plane. However, when the aircraft is pitched up in climb attitude either antenna provides nearly full coverage horizontally for a wide range of roll attitudes. In practice, the cabin-top antenna has been used exclusively for all flight operations except two experiments and has rarely failed to provide sufficient signal. Studies by both Langley Research Center and Boeing have indicated that the cabin-top location is preferred for most transport aircraft, with an optional bottom rear antenna for full coverage if required. It is assumed that the wheel-height-over-threshold requirement can be met by electronic biasing of the antenna position. If that is not the case, then a directional antenna on or under the nose will be required for some aircraft on final approach.

Light jets and small general aviation aircraft may often operate at small airports without radar vectoring, where procedure turns will be required. Smooth radiation patterns such as those of figure 4 are more difficult to achieve on this class of aircraft due to the sharper curvatures of surfaces and the relatively larger solid angles subtended by wings, engine nacelles, and the like. It may be desirable to investigate instrument approach procedures such that outbound maneuvering can be eliminated, rather than requiring the penalty of multiple antenna installations. This is true even of transport aircraft, where the cable runs may be quite long and require the installation of a preamplifier to obtain sufficient signal strength, in addition to causing a weight and installation cost penalty from the cable itself.

MLS Accuracy

Since MLS is an angle of measurement system, it was formerly the practice to define errors in terms of angular bias and noise. This method has been modified and errors are now specified by the method illustrated in figure 5. The MLS measurement is compared to an absolute position reference and a time history of the error is obtained which is then fed into standard filters. The path following filter is a low-pass filter with an output containing only errors with low enough frequencies to affect the aircraft's position. The path following error (PFE) consists of a mean course error (equivalent to an average bias error over the region of measurement) and path following noise. The control motion noise (CMN) filter is a high-pass filter which passes the frequencies which can cause rapid control motion but are of too short duration to result in an aircraft position displacement. In either case, a maximum error in either degrees or feet is specified, and as the sliding window is moved over the time history, this maximum error may not be exceeded more than 5% of the time. This method takes into account the fact that errors are not constant throughout the coverage volume due to multipath or propagation effects.

An illustration of the effects of PFE and CMN is shown in figure 6. This is a portion of the data obtained during Boeing simulations in which the MLS

deviation signals were directly substituted for ILS in the B-747 lateral autopilot. A direct channel propagation model produced the simulated MLS azimuth signal shown. The high frequency noise produced aileron deflections with a peak to peak amplitude of about 3° and a period somewhat larger than 1 second and rudder deflections of less than 1° with a somewhat longer period. As the bottom portion of the figure shows, the airplane displacements were of much longer period and were excited by the low frequency components of the azimuth noise. The maximum bank angle was less than 2° for this run. Preliminary results from this simulation indicate a lateral touchdown standard deviation of about 1.5 m (4.9 ft) for 10 runs.

Considerable data has been published giving error time histories and statistical error analyses of the TCV B-737 performance on various MLS paths (references 4-8). One example is given here: figure 7 summarizes the flight technical errors of the TCV B-737 autoland system at the Categories I (61 m (200 ft)) and II (30.5 m (100 ft)) decision heights, for approaches at Buenos Aires, New York, and Montreal. The performance is much better than required for FAA certification of Category II autopilots even though the final approach legs and lengths ranging from 3 km down to 0.8 km (1.6 to 0.44 n. miles). More significant is that these flight technical errors are also a good indication of absolute position errors, as discussed in references 6-8. The cross track errors were larger at the Category I decision height mainly because of the short final approach legs. In fact, for over 30 of the approaches (at JFK), the data are representative of RNAV delivery error rather than autoland tracking performance since the intercept of final approach occurred near the Category I decision height.

Errors at large distances and off centerline will probably be larger than those indicated in the preceding discussion. However, the MLS worst case accuracy should be equal to or better than the best performance which can be expected from VHF navigation and barometric altitude. Throughout most of its coverage volume the MLS will have much smaller linear errors than any other means of navigation.

CLASSES OF MLS USEAGE

Conventional ILS-type Approaches

MLS will initially be installed at many locations along with existing ILS. To prevent confusion during the early phases when both types of systems will be in use, the procedures are expected to be identical with present ILS practice. Pilots will probably notice very little difference from ILS under these conditions, other than possibly a more stable signal with fewer course bends. Depending on the airborne antenna coverage characteristics, there may be more flag activity during initial maneuvering than pilots are accustomed to with VHF or LF nav aids. Signals may be lost or not acquired on outbound headings with single-antenna installations.

Cockpit instrumentation will probably be the same as that used for ILS, except that if the wider proportional coverage of MLS is to be used to assist in capture of the final approach course, provisions will be necessary for either reducing CDI sensitivity during the capture phase or for providing some auxiliary display of azimuth angle to provide lead information. The minimum, or operationally preferred, glideslope angle will be a part of basic data transmitted from the ground equipment. This information must either be used to automatically set the receiver's elevation reference angle, or must be displayed to the pilot with provisions for preventing the use of lower angles. There is still some question as to whether the MLS should always use a 3° glideslope unless a larger angle is required for safety or if the glideslope should be set to match a lower ILS glideslope in the cases where MLS is colocated with such an ILS. If the MLS glideslope does not match the ILS, it may require higher weather minima since the approach lights and Visual Approach Slope Indicators are set to match the ILS angle.

Advanced Applications

Off-centerline Approaches. MLS receiving equipment with selectable azimuth and elevation reference angles will allow approaches on other than the 0° azimuth angle using conventional cockpit displays and techniques. An example of how such an approach might be used is given in figure 8, which is a published noise abatement procedure used extensively at San Francisco during the after-midnight hours. A conventional ILS approach to either runway 28L or 28R brings aircraft in over residential areas near the San Mateo bridge. The Quiet Bridge approach depicted uses VOR/DME in the early stages but is basically a visual approach requiring good weather. There is no positive vertical guidance, since the ILS glideslopes of 2.7° and 3° are both below the minimum altitude of 579.1 m (1900 ft) at the bridge.

An example of how MLS could be used for this approach is given in figure 9. The MLS is assumed to be colocated with the ILS on runway 28L. The vertical scale has been exaggerated since the angles are small. Note that an approach along the -6° azimuth radial closely adheres to the desired flight track. By selecting the 3.3° elevation reference angle, a stabilized descent with precise guidance may be started well before reaching the bridge at the specified altitude. After passing the bridge, a shallow left turn allows intercept of the final approach course 4 to 6 km (2.1 to 3.2 n. miles) from threshold, and elevation guidance is available throughout the entire procedure. Rather than intercepting the extended centerline for runway 28L, the transition may be made to the -3° azimuth angle. Accurate guidance is then furnished laterally and vertically to cross the final approach course for runway 28R approximately at the middle marker at a 3° angle. The improved guidance could enhance safety and reduce missed approaches for either runway, and as sufficient experience was gained the weather minima could be reduced.

Segmented Approaches. For aircraft with RNAV capability, MLS waypoints could be specified on the Bridge approach such that positive guidance was provided during the transition from the -6° to the -3° or 0° azimuth angles. Aircraft with more sophisticated computational capability and displays could

easily make manual or automatic approaches through touchdown.

Curved Approaches. A proposed solution to the San Francisco noise problem would require approaches over the bay with a left turn of greater than 90° to final approach to runway 19. Because of Oakland traffic conflicts, this must be accomplished at or within about 11 km (6 n. miles). Existing nav aids are inadequate for this task, and it was determined that the weather conditions deemed necessary to make this approach visually at night do not exist during a majority of the hours of interest. Such an approach could be easily handled with the wider proportional coverage of MLS.

An example of an over-water approach is shown in figure 10, which depicts two MLS approaches flown at Buenos Aires by the TCV B-737. These paths avoid overflying a city area with numerous high-rise apartment buildings, as the ILS approach does at altitudes as low as 305 m (1000 ft). The final approach legs here were 2 and 3 km (1.1 and 1.6 n. miles) in length. Figures 11 and 12 are photographs taken from the pilot's window on base leg and in the turn to final approach, respectively, on the path ABE05. The aircraft track is toward the right hand edge of the photo, and the runway may be seen at the left. The final approach course is intercepted over the athletic field beyond the two large buildings.

As performed by the TCV B-737, this type of approach is explicitly defined in 3 dimensions and the waypoint and altitude data are stored in the navigation computer bulk data in the form of a Standard Terminal Arrival Route (STAR). The path is easily entered into the flight plan by the pilot by merely calling for the STAR by name. This not only reduces workload by eliminating the necessity for entering each waypoint, but allows the waypoint locations to be defined more accurately than the 0.1' of latitude and longitude which is normal with present-day control and display units. This resolution does not take advantage of MLS accuracy, and is insufficient for curved, close-in intercepts of final approach.

In order to allow the definition of curved, continuously descending flight paths, the TCV MLS signal processing used a coordinate conversion from the MLS conical coordinates to a runway-based rectangular coordinate system. After filtering, the rectangular coordinate data were again transformed into Inertial Navigation System-equivalent data for input to the existing navigation computer system, and to ILS-like deviation data for the autoland system and displays. This is a rather cumbersome process, with the added disadvantage that no MLS data can be used unless all angle and range data are available. However, it does allow the definition of complex flight paths and touchdown points independent of ground station geometry so long as the path stays within coverage of all signals. In future system designs a capability to use azimuth and range information of RNAV along with barometric altitude and to intercept and track specific azimuth and elevation angles directly is desirable.

An important factor when an explicit path is to be followed is the navigation error existing at the time MLS coverage is entered and a change is made to MLS guidance. Depending on the available nav aids and geometry, and the

aircraft navigation capability, large discrepancies may exist between the position estimate and the actual aircraft position. Similarly, there are likely to be altitude errors due to aircraft instrumentation errors and non-standard atmospheric conditions. Flight path design must take the size of these errors and the MLS coverage characteristics into consideration so that sufficient flight time within MLS coverage is allowed for a smooth and gentle correction prior to attempting the final intercept turn, since correcting track errors in a turn is more difficult and may result in undesirable aircraft maneuvering. This is especially true if the aircraft happens to be on the outside of the turn. Figure 13 illustrates a typical situation during entry of the TCV airplane into MLS coverage and a 130° turn to a 5.6 km (3 n. miles) final approach leg. This is the same path described for other flights at NAFEC in references 4 and 5. The error data was obtained by phototheodolite tracking from the ground. At the beginning of the plot, waypoint DD135, the airplane was to begin a 3° descent. A cross track position error of about 100 m is apparent, with a standard deviation of about 75 m. A larger along-track error is implied by the rapid increase of altitude error initially, indicating that the aircraft passed the waypoint before beginning descent. At the edge of the MLS coverage region, the mean cross track error has decreased to near zero but the dispersion is unchanged. The altitude error has settled at about 30.5 m (100 ft). At this point the cross track error dispersion is seen to begin decreasing as the switch is made to MLS guidance. The mean altitude error rapidly decreases to near zero and at the same time the dispersion is reduced. Further improvement in the dispersion is seen as the final approach leg is intercepted and the autoland system takes over. During these flights no special provision was made for the transition from conventional to MLS guidance. Rather, any existing error was fed to the guidance algorithms as a step input when the MLS guidance switch was enabled. This proved acceptable for most of the flights, since navigation errors are a minimum with a dual DME updated inertial navigation system such as used on the TCV B-737. However, with the occasional larger errors experienced, maneuvers tend to become abrupt and it is desirable to provide a blanding technique for smooth transition to the MLS guidance. Such techniques are planned for flight testing on the TCV B-737.

A summary of the cross track and altitude errors experienced by the TCV airplane during flights at Buenos Aires, New York and Montreal is given in figure 14. The mean cross track error of -79 m can be expected to approach zero as data is included for additional locations and flight geometries, but the dispersion is probably representative of what can be expected using this type of inertial/DME/DME navigation. On the few occasions when VOR data has been used, errors of about 2 km have been seen. The altitude error here also shows a bias, which could be due in part to the fact that the flights at JFK and Montreal were performed in cold weather when the barometric altimeter would tend to read low. Other factors could be along track navigation errors for any approaches where MLS entry occurred during a descent, or errors in the MLS equipment or on-board processing.

Canarsie Approach to JFK. A published curved instrument approach procedure, the VOR RWY 13L/13R (Canarsie) approach to John F. Kennedy airport

is shown in figure 15. Although this is an instrument approach, the curved portions must be flown by visual reference to a series of flashing lead-in lights; thus relatively high ceilings and visibilities are required. The approach to runway 13R, in particular, requires basic VFR weather conditions. The approaches are difficult to fly since the curved path must be tracked by reference to a few visual cues, which may be difficult to pick out from the city lights at night, and at the same time a descent must be made with no vertical guidance. Pilots frequently overshoot the curve and fly over the residential district, which the approach is designed to avoid.

Figure 16 shows an experimental MLS installation at JFK which was used by the TCV B-737 to demonstrate the conversion of the Canarsie approach to a precision approach to touchdown. The azimuth antenna provided $\pm 60^\circ$ coverage. Two different elevation antennas were tested at JFK by the FAA. The one in use during the TCV flights was the Basic Narrow system with centerline emphasis so that elevation coverage was not matched to the azimuth system and was marginal in the vicinity of CRI. The result was that the elevation signal was sometimes lost for brief periods early in the approach as the airplane maneuvered. The black triangles show the points at which the pilots switched to MLS guidance. This varied widely for several reasons, but a contributing factor was loss of confidence when the pilots coupled to the MLS early and then lost the elevation signal in the resulting transition maneuver. With an operational system this should not be a problem since the elevation and azimuth coverages would be matched.

If a $\pm 40^\circ$ azimuth system had been used, all transitions to MLS guidance would have been delayed until near the turn entry, often leaving insufficient time to correct the navigation errors before entering the turn. Further, if terminal procedures were to require that MLS approach procedure design could include only the $\pm 40^\circ$ sector originating at the datum point, as illustrated in figure 2, MLS could not be assumed valid prior to reaching the start of the turn, which is the missed approach point in today's procedure. Thus only a $\pm 60^\circ$ system can be used for this approach. Even as measured from the datum point, this allows adequate time to acquire the signals in the vicinity of CRI and correct any navigation and altitude errors.

The MLS on runway 13L could be used to provide VNAV approaches to both runways, allowing lower weather minima than are presently required and improving the utility and accuracy of the approaches. With TCV type signal processing, autolands would be possible on either runway using the same MLS ground station. For runway 13R the final approach course could be simply offset using the same technique which was used at Montreal, where the azimuth antenna was installed off-centerline to allow installation of the British Doppler MLS on the same runway. While the use of such methods may be questioned today, the technical feasibility was clearly demonstrated over two years ago. The use of an MLS for RNAV or VNAV approaches to more than one runway could increase the utility of these types of approaches without the added cost of complete systems on every runway. However, in the beginning, confidence can probably be best gained by using the MLS primarily to improve the accuracy and

safety of the visual portions of these approaches and to reduce the weather minima later as experience shows to be appropriate.

La Guardia Expressway Approach. A final example of a current curved, descending noise abatement approach is the La Guardia Expressway Approach in figure 17. The curved portion is even less well defined than the JFK approaches just discussed, since there are no lead-in lights or other visual cues to define the curve. The pilot must locate and visually follow a particular highway system, turning over Flushing Meadow Park to intercept a very short final approach, all the while making a steeper than normal descent without guidance. The procedure calls for a ceiling of 914.4 m (3000 ft) and visibility of at least 8 km (5 mi), considerably greater than basic VFR requirements. The problem with making this an MLS approach is that even a standard $\pm 60^\circ$ MLS does not provide sufficient coverage due to the large turn and very short final approach leg.

There are some possible ways in which MLS could be used for the Expressway Approach. Illustrated in figure 17 is a way to do it with a single $\pm 60^\circ$ MLS on runway 31. The azimuth and elevation antennas are rotated by about 40° toward the side on which additional coverage is required. This would allow the signals to be acquired during the initial inbound leg toward the airport in plenty of time to establish accurate path tracking and a stabilized descent before reaching DIALS intersection and turning to base leg. However, any conventional users approaching along the runway centerline would be required to track the -40° azimuth angle rather than 0° . It is technically a simple matter to set this reference angle into the receiver automatically using data transmitted by the ground equipment, or the pilot could be required to select the proper reference angle as part of the cockpit procedure. This technique would still allow 20° of proportional coverage on the north side of the runway, well in excess of the required 10° minimum. It would also allow VNAV approaches to runway 4 using the same installation. This technique would require that the present proposed practice be modified, since it calls for the 0° azimuth angle to be aligned with the runway centerline.

A second possibility would be the installation of another MLS on runway 4 in addition to the one on 31. The runway 4 system could be used during the initial part of the approach to provide accurate VNAV guidance and the runway 31 system used for final approach. The disadvantages are that twice as much ground equipment is required, and the airborne equipment would require either an additional MLS receiver dedicated to area navigation or frequency retuning at a critical point in the approach.

A final potential solution is the 360° azimuth option, which is considered a possible growth feature of the MLS. Assuming that the accuracy would be comparable to the approach azimuth, this would solve the lateral guidance problem. However, there would still be a problem with altitude errors. Recall from figure 14 that errors of a few hundred feet would not be uncommon. An error of this magnitude needs to be detected and corrected before reaching DIALS intersection because of the shortness of the path and the fact that the approach is already somewhat steeper than 3° and a fly-down error indication

might result in higher than desirable descent rates. Since much of this error is caused by non-standard atmospheric conditions, the size of the transition is to some extent determined by the altitude at which it occurs. Figure 14 included data on transitions occurring from 610 to 1524 m (2000 to 5000 ft) MSL. Table I summarizes the differences between barometric, radio and MLS altitudes at several points along the final approach path at Buenos Aires. These points were all below 182.9 m (600 ft) MSL. The mean difference between barometric and MLS altitudes this near the ground is seen to be about 12.2 to 15.2 m (40 to 50 ft), with a standard deviation of 15.2 to 18.3 m (50 to 60 ft). An attempt was made to correct radio altitude for the approximate terrain elevation, and the results show good agreement with the MLS altitude. The larger dispersions of 3.7 and 4.0 m (12 and 13 ft) at two points show the terrain dependence of the radio altimeter. These were due to the effects of street traffic and trees at one point, and a double row of approach lights at the other.

The conclusion which may be drawn is that MLS altitude accuracy is comparable to that of radio altimeters, and MLS is preferable for obstacle clearance and landing guidance since it is terrain independent. However, there is a transition which may be hundreds of feet in magnitude required to change from barometric to MLS altitude. This transition problem increases with altitude, and must be considered in the design of MLS approaches.

USE OF MLS AT COVERAGE LIMITS

Lateral Coverage

All discussions to this point have been concerned with MLS near the airport traffic pattern. The minimum specified coverage extends to a range of 20 n. miles and an altitude of 6096 m (20 000 ft). During normal conditions, the signals will probably be received at much greater distances. During the first TCV B-737 tests using MLS, valid signals were received in excess of 55 km (30 n. miles). Since it has been implied that it is desirable to correct navigation errors as early as practical in an approach, let us consider the use of MLS at the coverage limits.

Figure 18 illustrates a hypothetical installation of two $\pm 60^\circ$ systems at Denver, which provide coverage for all arrival routes. The Denver terminal area is of interest because of the experiments with traffic metering and profile descents, which may result in similar traffic arrival patterns being used more widely in the future. Note that even the minimum system range of 37 km (20 n. miles) allows MLS use during the last part of the profile descent, and it is quite likely that under most conditions signals will be acquired much further out--perhaps at the metering fixes. The question, then, is what use might be made of MLS under those conditions.

It is obviously advantageous to use MLS to update the navigation position estimate as early as possible so that any necessary corrections can be made smoothly and expeditiously. The procedure depicted is the high profile descent, which would be in use for traffic being routed to a downwind leg for landing opposite the initial approach direction. With only the two systems shown, aircraft would temporarily leave MLS coverage on downwind leg. If MLS

were installed on the east-west runways, a switch to that system could be made on downwind for continuous MLS guidance. In either event, another frequency change would be required for the final approach phase. If the 360° azimuth and DME option were available, the landing MLS could be tuned initially and accurate lateral guidance would be available continually with no further action.

MLS Altitude

In the case illustrated in figure 18, it would be possible to compute MLS altitude at initial entry to the MLS coverage region. However, an area navigation study done for the FAA several years ago (reference 9) showed that vertical separation would be compromised by mixing traffic using barometric altitude with traffic using MLS altitude, and it is not reasonable to expect all traffic in the terminal area to be using MLS altitude. The problem is mainly due to the large errors in barometric altitude which can occur under non-standard conditions. These errors affect all aircraft in the same vicinity by approximately the same amount, so that relative separation is not affected. Absolute errors are accounted for by the requirement for a minimum altitude of 305 m (1000 ft) above the highest obstacle within 8 km (5 mi) (610 m (2000 ft) in mountainous areas). One conclusion of that study was that with mixed barometric and MLS altitudes, a vertical separation of 2000 ft would be required. This study limited the conditions to an altitude of 3048 m (10 000 ft) and an airspeed of 250 kts. As just shown in figure 18, aircraft will be within MLS coverage at altitudes of 6096 m (20 000 ft) or more and in many cases they may be at airspeeds greater than 250 kts. Table II shows a summary of the results from reference 9 and an extension of the analysis to include an altitude of 20 000 ft and airspeed of 350 kts. A slightly larger MLS error is also used to conform more closely to current proposals, but this is an insignificant perturbation. The column labelled "noise error" is composed primarily of the maximum random errors which can occur due to non-standard temperatures, lapse rates and horizontal pressure gradients. By the rule of thumb given in the reference, the vertical separation must be increased by about 1000 ft over that calculated for the lower altitude and airspeed. A possible need to change terminal area vertical separation from 305 to 914 m (1000 to 3000 ft) would appear to be a good argument against the early use of MLS altitude.

A second disadvantage of early use of MLS altitude would be the magnitude of the correction necessary after switching from barometric to MLS altitude. This could occur during the profile descent phase and result in either a loss of some of the fuel savings or inability to correct the error, if a fly-down error signal were received while descending at idle power. Transition methods would have to be very gradual to compensate for altitude errors of 1000 ft or more in a reasonable fashion. One simple way to achieve a gradual reduction of altitude error to a more reasonable value is to wait until reaching a lower altitude before making the switch.

To summarize, MLS altitude is essential for purposes such as curved, descending flight paths and is very desirable for obstacle clearance and

guidance in the final approach phases and landing. However, its use at higher levels creates problems which do not appear to have a ready solution. Further analysis and experimentation is required to define the conditions under which MLS altitude should be used.

OPTIONAL MLS FEATURES

Little or no experience has been gained with the use of the proposed MLS growth features. Therefore, only a few general comments will be made about their possible applications or characteristics.

360° Azimuth

This paper has mentioned several potential applications for an omnidirectional azimuth function, and the MLS signal format does contain growth potential to allow its implementation. At this time, however, it is strictly in the conceptual stage. In the early planning stages of MLS, a $\pm 90^\circ$ coverage was felt to be an operational requirement for a full service system (reference 1), but this was modified to $\pm 60^\circ$ because of practical considerations regarding implementation. The emphasis at present is concentrated on the lesser capability systems with proportional coverage of $\pm 40^\circ$ down to $\pm 10^\circ$ (reference 3). Every reduction from $\pm 90^\circ$ coverage increases the need for a 360° azimuth subsystem, and the requirements for accuracy become more stringent to insure that navigation problems can be corrected before reaching a critical phase in the approach. The problem of transition from barometric altitude, however, will not be solved by the implementation of this function.

Back Azimuth

Flight tests have been conducted using MLS installations which had an azimuth subsystem installed in the back azimuth location, and performance standards for this function are under development. Some questions remain as to the use of this function. Figure 19 illustrates the proposed azimuth scanning conventions. This convention will result in a change of sign of the deviation signal at a change from approach to back azimuth. This can be easily handled by having the receiver reverse output polarity for the back azimuth function, so that the CDI deflections will follow the same conventions as for ILS. However, the angular course deviations as measured by the two systems will not be of the same magnitude except midway between the antennas. A switch from approach to back azimuth will therefore usually result in a change, perhaps large, of CDI deflection; or in the case of automatic flight operations will result in a step error input to the autopilot. Figure 20 shows that during much of the time the aircraft is over the runway, there will be a choice of using either approach or back azimuth information. It must yet be established whether the switch to back azimuth is to be made automatically in the receiver or initiated by the pilot. In either case, criteria for making the switch must be defined and some transition method developed to smooth the possible jump in error magnitude.

In the TCV B-737 flight tests, the back azimuth signal was used only as a sensor input for updating the RNAV position solution after the approach azimuth signal was lost. A desirable feature of this technique is that the pilot always follows the same procedures and uses the same displays regardless of the availability of back azimuth guidance. The back azimuth here has no effect except to improve the accuracy of the RNAV position.

MLS Flare Guidance

The MLS flare elevation function has been flight tested in two versions by the TCV B-737. Performance standards for this function are presently being developed. The primary function of the flare elevation system is to provide a source of altitude data equal to or better than a radio altimeter during the flare and landing phase, when the approach DME and computational capability are also required. During most of the TCV flights, flare elevation was substituted for approach elevation whenever it became available rather than waiting until the latter was about to be lost. This eliminated any possibility of problems arising from changing altitude guidance in a critical flight phase near the ground, and performance on the glidepath was somewhat better due to the narrower beam width of the flare elevation system.

One alternate use that could be made of the flare elevation system by aircraft without precision DME or computations is the segmented glidepath approach illustrated in figure 21. In this procedure a normal glidepath would be flown on the approach elevation system, and a transition would be made to a smaller angle glidepath upon intercepting the desired angle from the flare elevation antenna. This angle would be chosen to provide the desired touchdown sink rate, thus eliminating the need for a final flare maneuver. Several examples are given for the TCV B-737, assuming an MLS antenna height of 4 m above the runway at touchdown. The transition altitudes and touchdown sink rates for the 0.6 to 0.7° glidepaths are comparable to the normal flare, except that the latter is a gradual continuous maneuver rather than a discrete transition to a flatter glidepath. This type of landing maneuver has been tested on an earlier experimental guidance system. One of the potential problems with such a procedure is that the touchdown dispersion would probably be greater than that achieved using present TCV flare control laws (reference 10). An estimate of touchdown dispersion for each glidepath is given in the figure. It was obtained by using the glidepath tracking dispersion from figure 7 and the tangent of the glidepath angle. In practice, the values might be either better or worse depending on how closely the glidepath was tracked at these shorter ranges and what the effects of transitioning to a new glidepath were. There might also be problems in providing a single ground antenna geometry suitable for a wide range of aircraft characteristics.

CONCLUDING REMARKS

Many of the uses originally envisioned for a new precision approach and landing aid, such as curved approaches for noise abatement purposes and

automatic landings, have been clearly demonstrated to be technically feasible by TCV B-737 flights. With regard to the technical requirements, there is no reason why such procedures could not be put into use within a few years, since the new aircraft which are currently on production lines will have electronic displays and computational capabilities suitable for emulating or improving on the TCV experience. Reasons why these capabilities may not be exploited soon are the lack of defined procedures and conventions, opposition by pilots and air traffic controllers without training and experience in these types of operations, and possible deficiencies in ground station and/or airborne equipment capabilities.

It has been TCV program experience that during the MLS flight tests, most air traffic controllers and guest pilots developed confidence in the airplane's ability to follow complex flight paths and traffic clearances, after they were briefed on the aircraft systems and saw from actual flight operations that they worked as advertised. It is suggested in this paper that a good way to smooth the way for the use of MLS for complex noise abatement procedures is to start with existing visual approaches. This would cause a negligible perturbation to present air traffic control procedures and could reduce pilot workload (with the proper displays), increase safety and flight path accuracy, and reduce missed approach frequency. The resulting operational experience would help to provide the confidence needed for the reduction of weather minima on existing approaches and influence the design for new procedures.

The other factors which could delay or prevent the full realization of the potential of MLS are technical ones involving coverage volume and the provision for special techniques to increase coverage asymmetrically where required. While it is desirable to simplify the transition from ILS to MLS by the use of common procedures, it must be emphasized that a "minimum" performance standard is exactly that. Many proposed uses of MLS will require additional capability, and may require special techniques or data transmissions. These should be carefully considered and coordinated with the needs of early conventional users of MLS to insure that future applications are not inadvertently restricted.

REFERENCES

1. Walsh, Thomas M., Morello, Samuel A., and Reeder, John P.: Review of Operational Aspects of Initial Experiments Utilizing the U. S. MLS. NASA SP-416, 1976, pp. 3-30.
2. A New Guidance System for Approach and Landing. Radio Technical Commission for Aeronautics Document No. D0-148, December, 1970.
3. Non-Federal Navigation Facilities; Proposed Microwave Landing System Requirements. Notice of Proposed Rulemaking No. 80-15, Federal Aviation Administration, DOT. Federal Register 45, no. 175, Sept. 8, 1980.
4. The TCV B-737 Flight Performance During the Demonstration of the Time Reference Scanning Beam Microwave Landing System to the International Civil Aviation Organization All Weather Operations Panel. Boeing Commercial Airplane Company Document no. D6-44291, February, 1977.
5. White, William F., et al.: Flight Demonstrations of Curved, Descending Approaches and Automatic Landings Using Time Reference Scanning Beam Guidance. NASA TM 78745, May, 1978.
6. White, William F., and Clark, Leonard V.: Flight Performance of the TCV B-737 Airplane at Kennedy Airport Using TRSB/MLS Guidance. NASA TM 80148, July, 1979.
7. White, William F., and Clark, Leonard V.: Flight Performance of the TCV B-737 Airplane at Jorge Newbery Airport, Buenos Aires, Argentina Using TRSB/MLS Guidance. NASA TM 80223, January, 1980.
8. White, William F., and Clark, Leonard V.: Flight Performance of the TCV B-737 Airplane at Montreal/Dorval International Airport, Montreal, Canada Using TRSB/MLS Guidance. NASA TM 81885, September, 1980.
9. Hemesath, N. B., et al.: Three and Four Dimensional Area Navigation Study. Federal Aviation Administration Report RD-74-150, June, 1974.
10. Hueschen, R. M., Creedon, J. F., Bundick, W. T., and Young, J. C.: Guidance and Control System Research for Improved Terminal Area Operations. 1980 Aircraft Safety and Operating Problems, NASA CP-2170, 1981. (Paper 4 of this compilation).

TABLE I. - COMPARISON OF MLS WITH
BAROMETRIC AND RADIO ALTITUDES

Location	No. of Points	Barometric minus MLS Altitude, ft	Radio minus MLS Altitude, ft
3 km Final Approach Fix	43	53.1 ± 47.5	17.1 ± 3.6
2 km Final Approach Fix	10	14.5 ± 67.3	15.5 ± 2.4
Cat I DH	53	41.8 ± 56.0	12.6 ± 3.2
Decrab Initiation	53	46.4 ± 51.9	6.9 ± 13.1
Cat II DH	52	41.0 ± 57.6	2.7 ± 12.1
Flare Initiation	52	39.2 ± 56.8	0.2 ± 2.3
Touchdown	34	27.1 ± 63.6	0.5 ± 1.8

TABLE II. - RELATIVE POSITION ERRORS FOR MLS VERSUS
BAROMETRIC ALTITUDE AT A RANGE OF 20 NAUTICAL MILES

	Bias Error, ft	Noise Error, ft	Minimum Separation, ft
(1) Altitude ≤ 10 000 ft Airspeed ≤ 250 kts	330	895	1 710
(2) Altitude = 20 000 ft Airspeed = 350 kts	570	1 720	2 720

- (1) Data from reference 9.
(2) Assumes maximum PFE of 300 ft, treated as bias error, and 350 ft static defect error.

(Note: 1 ft = 0.3048 m.)

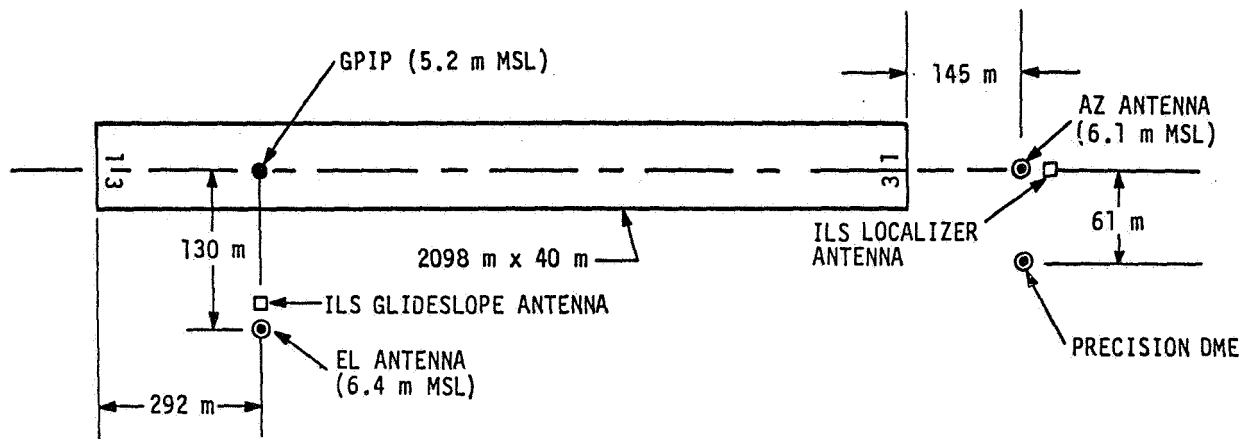

Figure 1.- MLS configuration for runway 13 at Jorge Newbery Airport, Buenos Aires, Argentina.

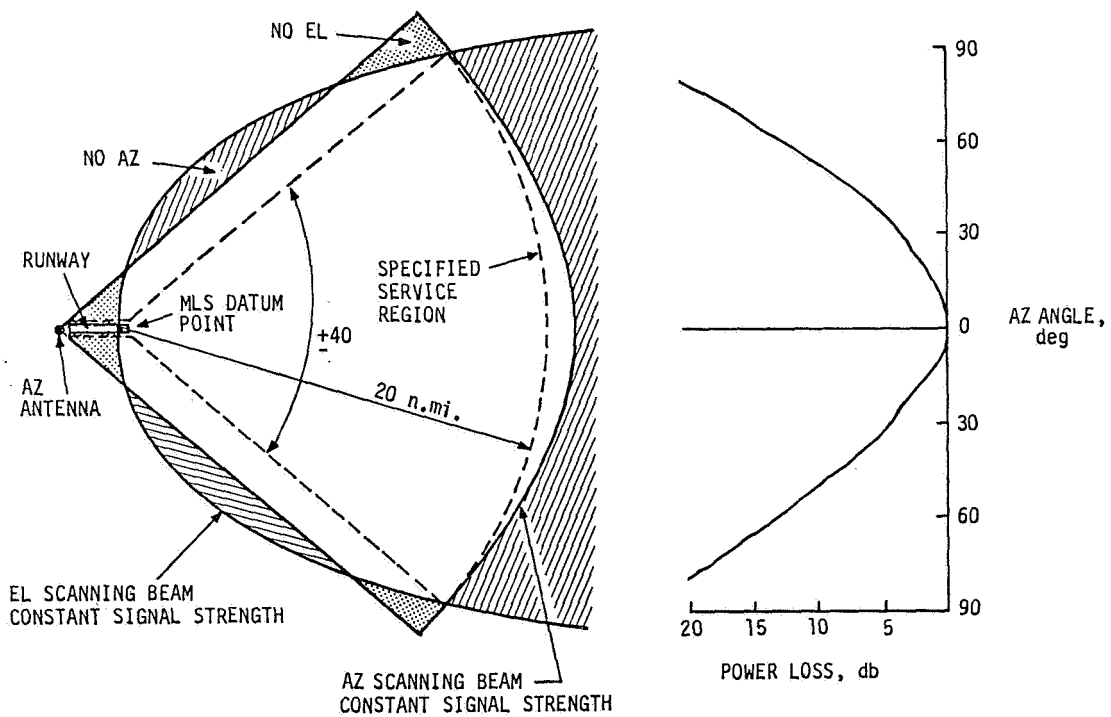

Figure 2.- Typical MLS centerline emphasis antenna pattern and resulting lateral coverage area.

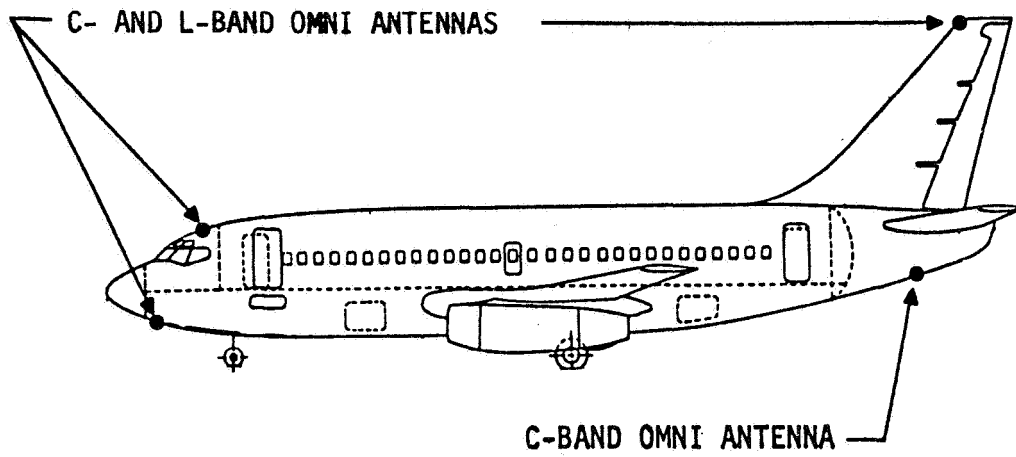

Figure 3.- MLS antenna locations which have been flight tested on the TCV B-737.

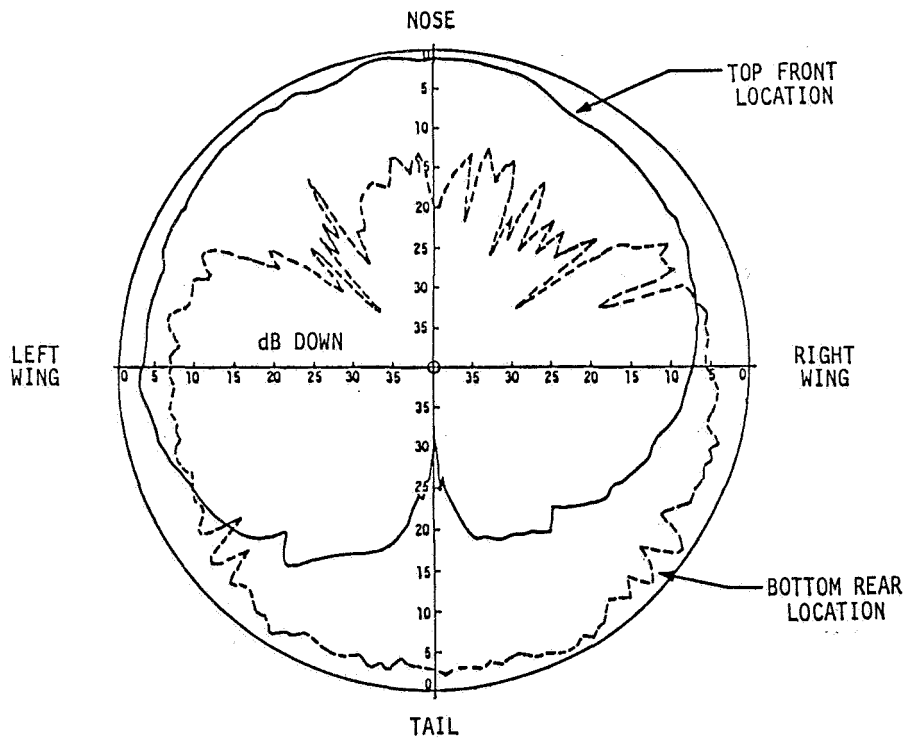

Figure 4.- Azimuthal plane radiation patterns of monopole antennas on TCV B-737.

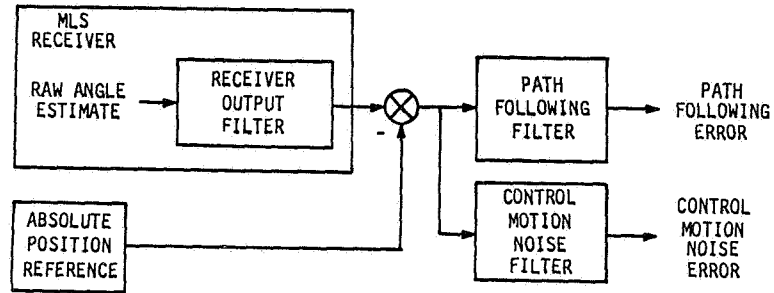
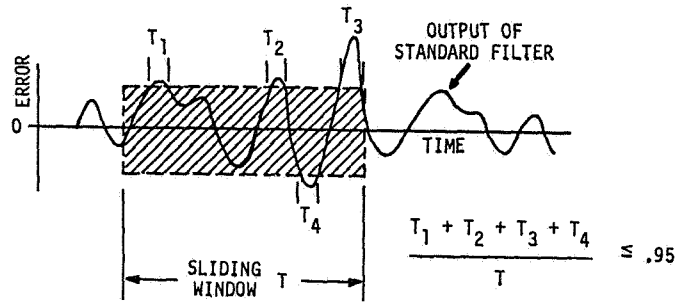

Figure 5.- MLS error specification methodology.

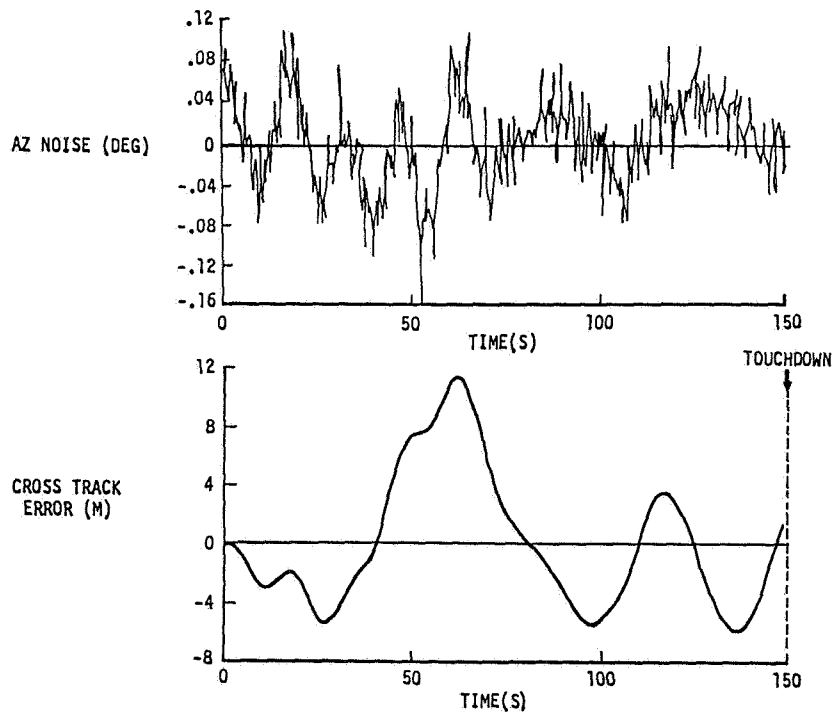

Figure 6.- Example of simulated B-747 lateral autopilot performance with MLS substituted for ILS.

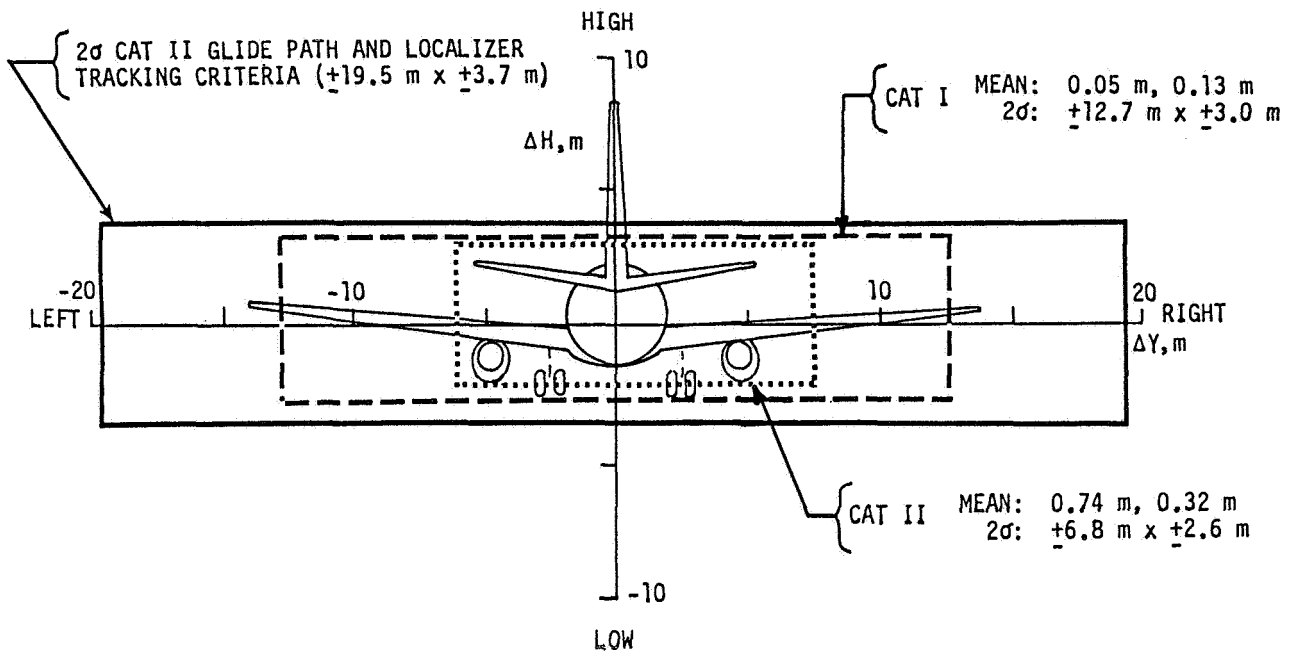

Figure 7.- Summary of TCV B-737 autopilot performance utilizing MLS guidance.

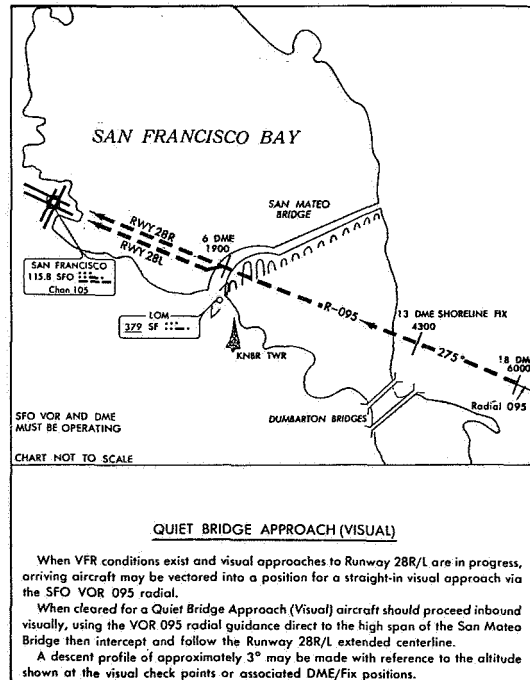

Figure 8. - Example of off-centerline noise abatement approach. (Note: 1 ft = 0.3048 m.)

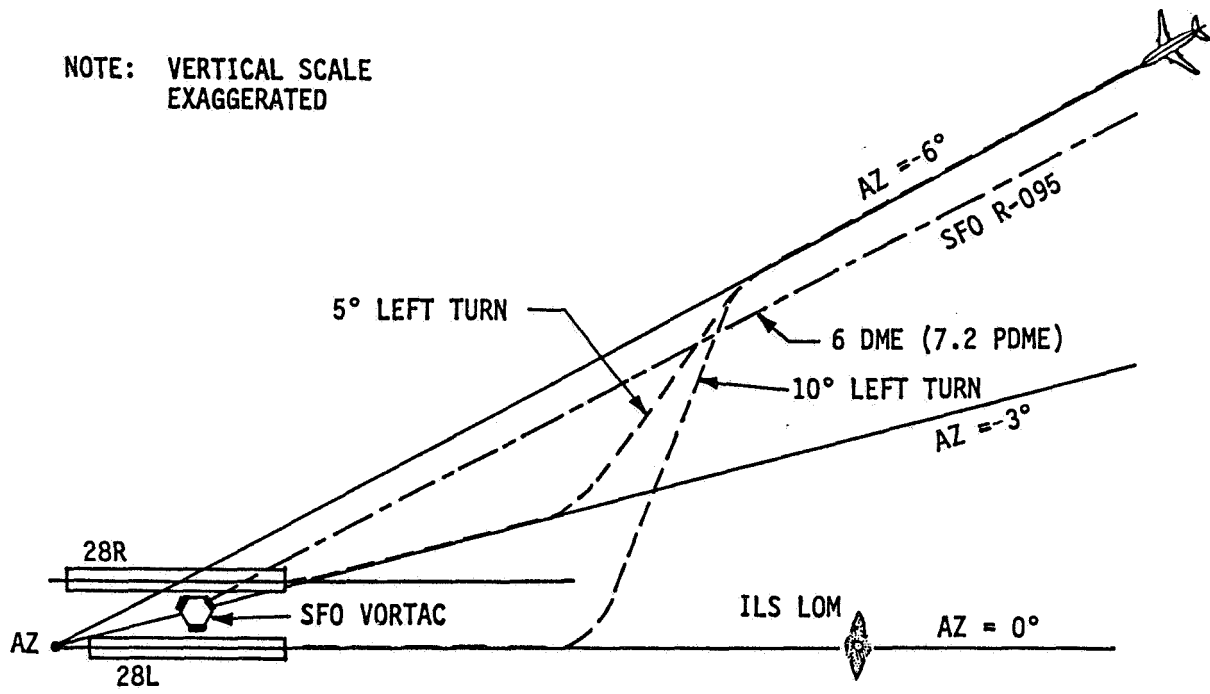

Figure 9.- Possible MLS version of San Francisco Quiet Bridge Approach.

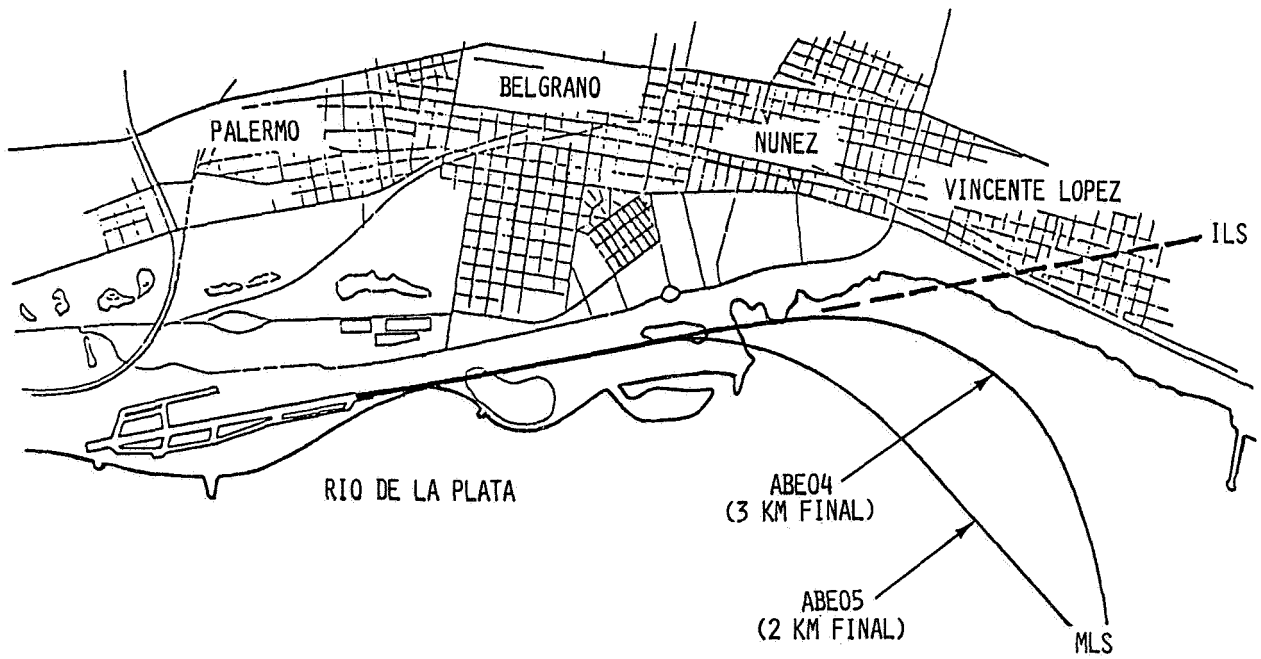

Figure 10.- Approach paths for automatic MLS landings by TCV B-737 at Jorge Newbery Airport, Buenos Aires, Argentina.



Figure 11.- View from TCV B-737 cockpit on base leg of noise abatement approach at Buenos Aires, Argentina.

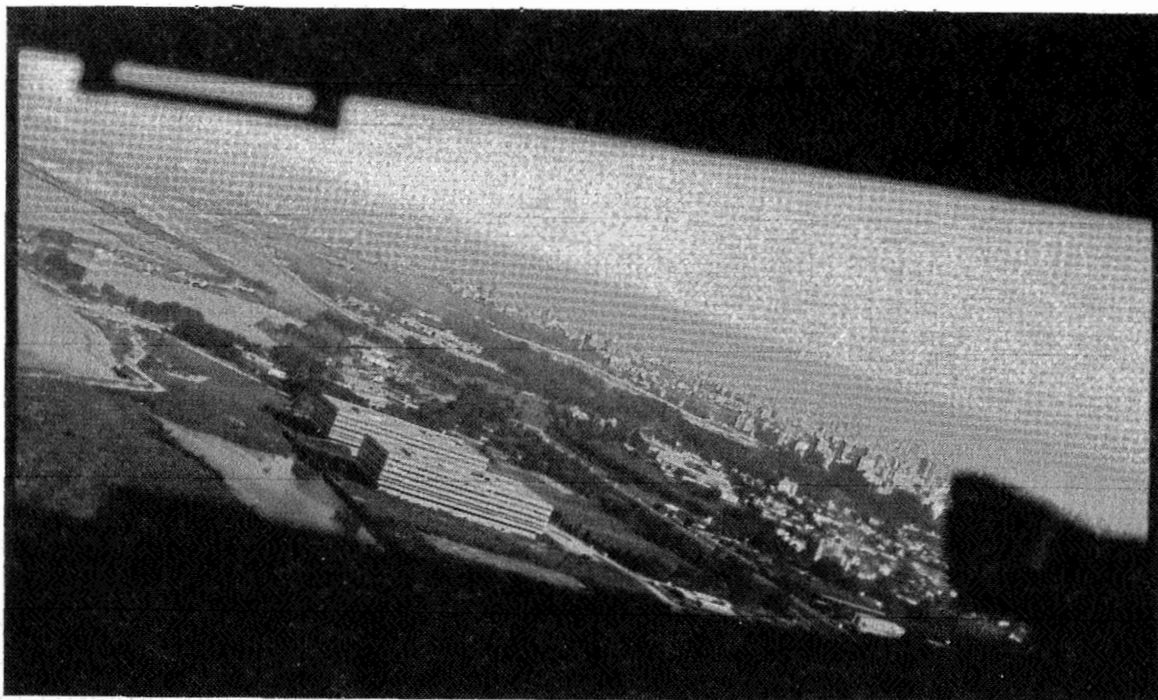

Figure 12.- View from cockpit of TCV B-737 intercepting 2 km (1.1 n. mile) final approach at Buenos Aires, Argentina.

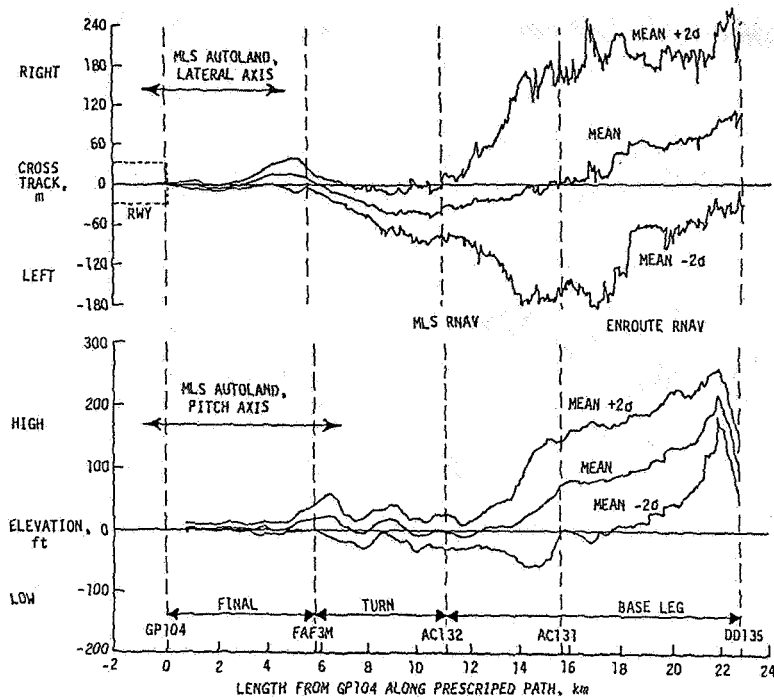

Figure 13.- TCV B-737 path deviation for 130° turn to 5.6 km (3 n. mile) final approach leg. (Note: 1 ft = 0.3048 m.)

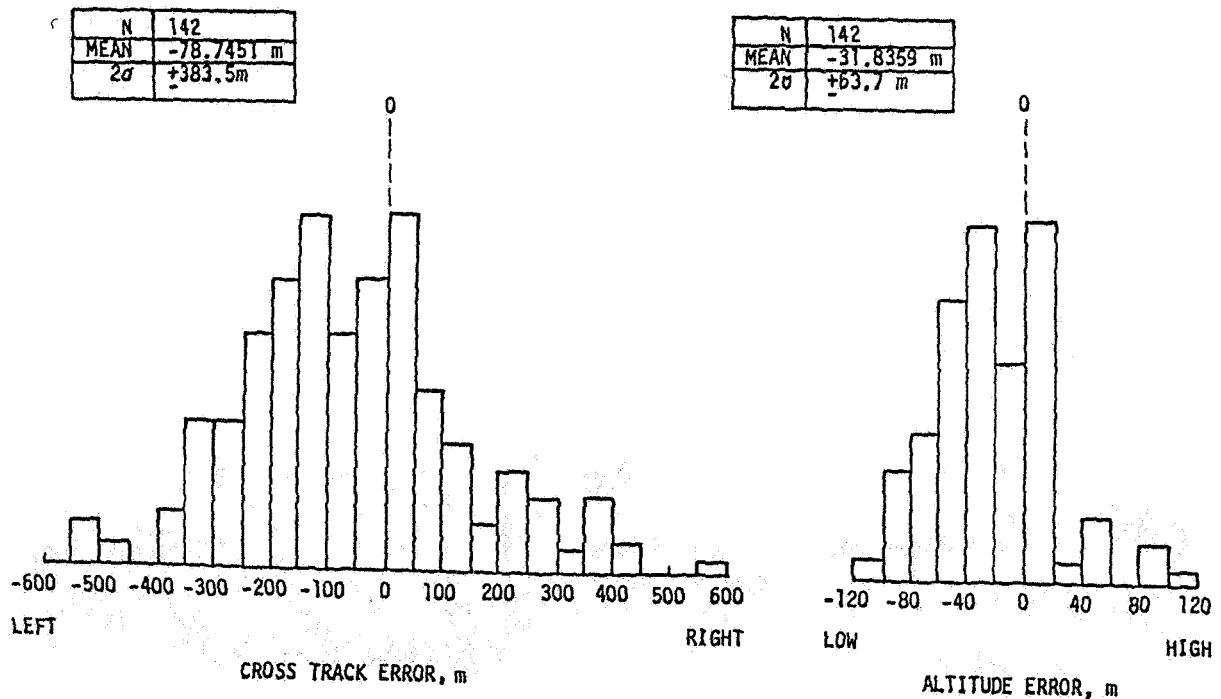

Figure 14.- Summary of conventional-to-MLS RNAV path differences for TCV B-737 approaches to JFK, Jorge Newbery, and Montreal/Dorval International Airports.

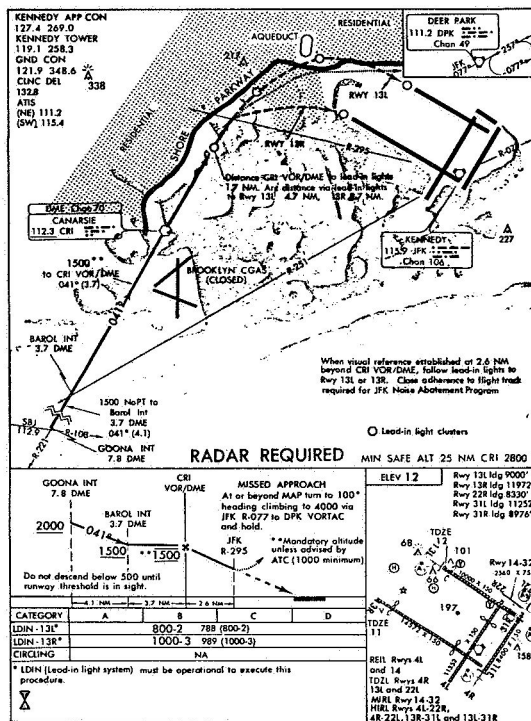

Figure 15. - Example of current curved noise abatement approach procedure. (Note: 1 ft = 0.3048 m.)

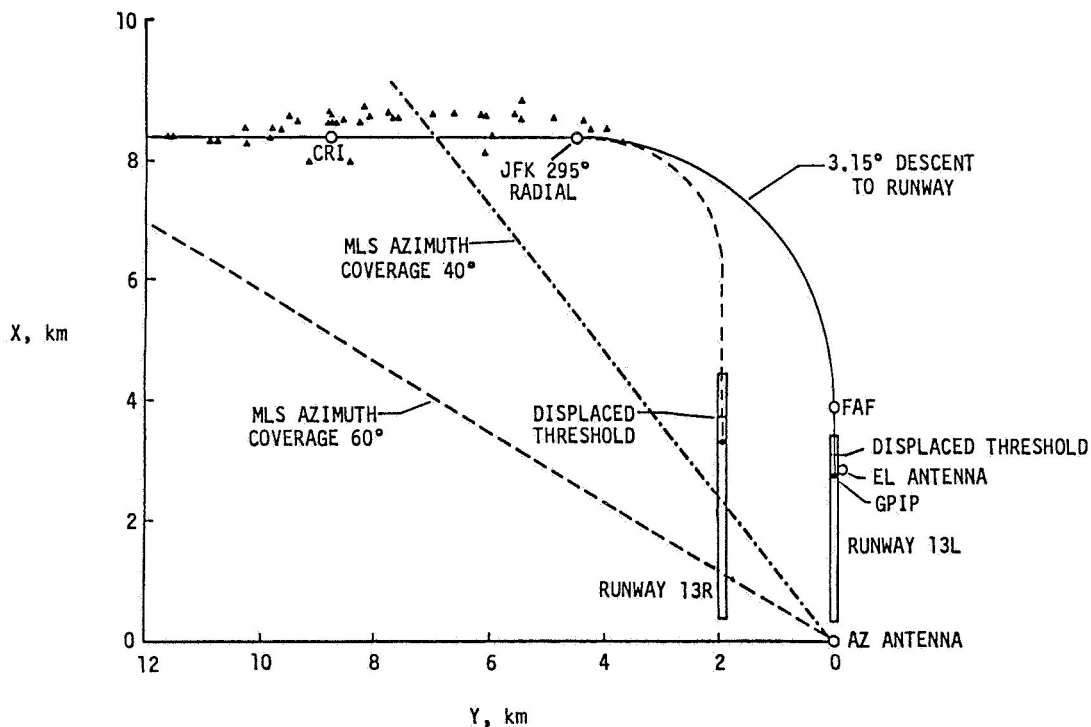

Figure 16.- Summary of conventional-to-MLS RNAV lateral transitions for TCV B-737 approaches to JFK.

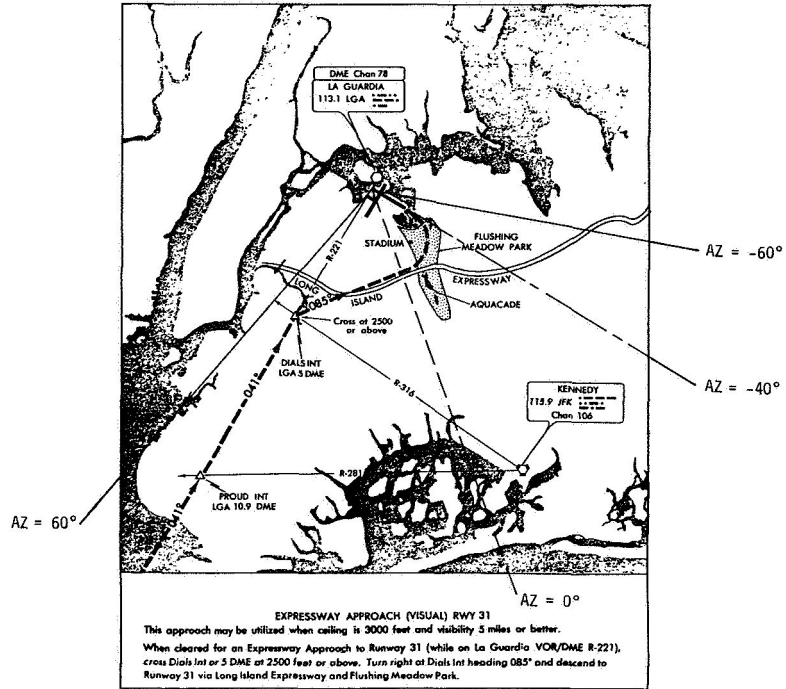

Figure 17.- Possible solution to coverage volume problem for La Guardia noise abatement. (Note: 1 ft = 0.3048 m and 1 mi = 1.61 km.)

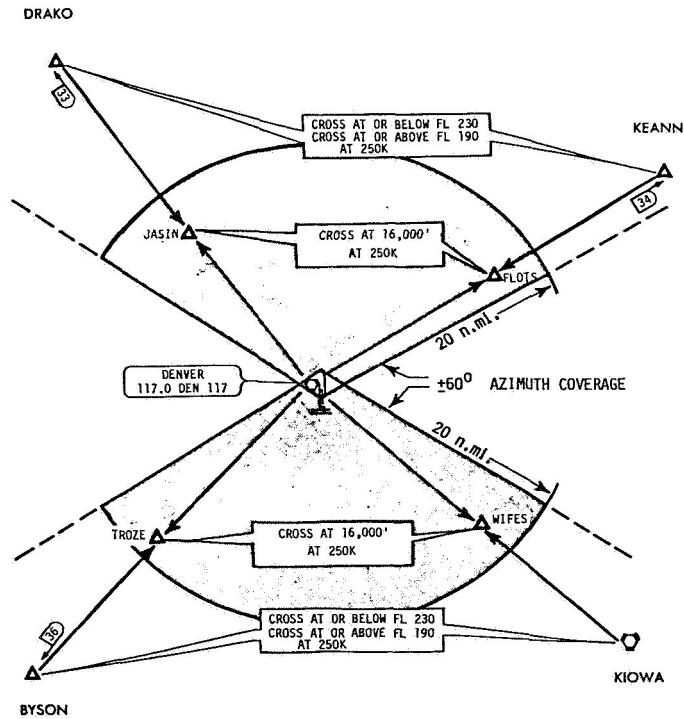

Figure 18.- Possible MLS configuration for Denver terminal area. (Note: 1 ft = 0.3048 m.)

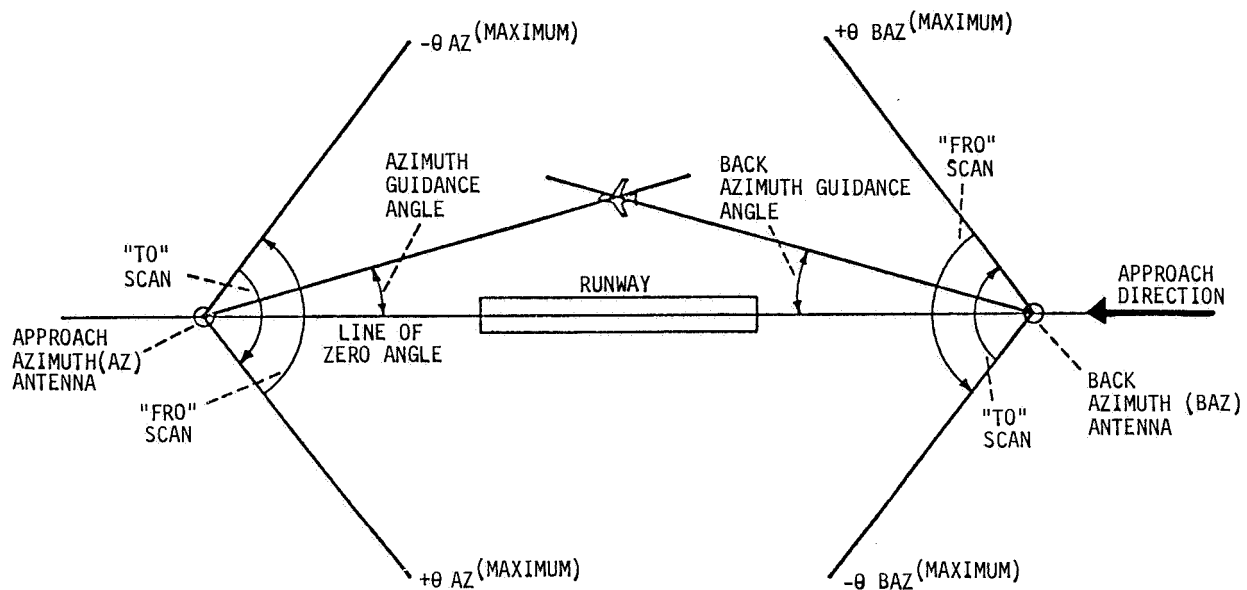

Figure 19.- Azimuth guidance functions scanning conventions.

NOTE: VERTICAL SCALE = TWICE HORIZONTAL SCALE

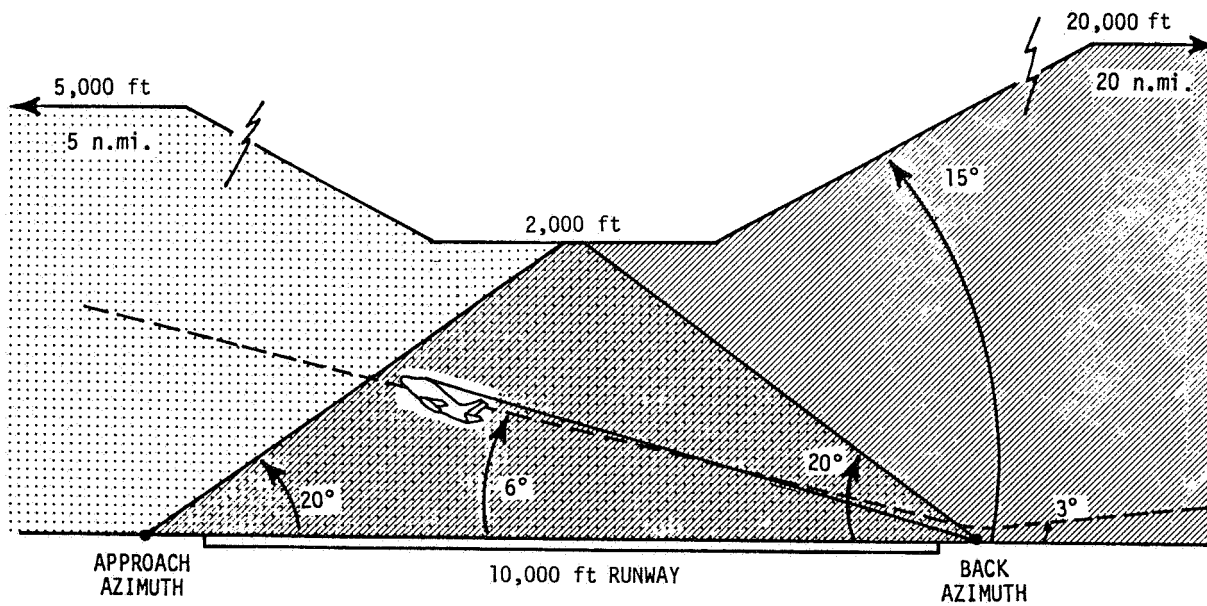
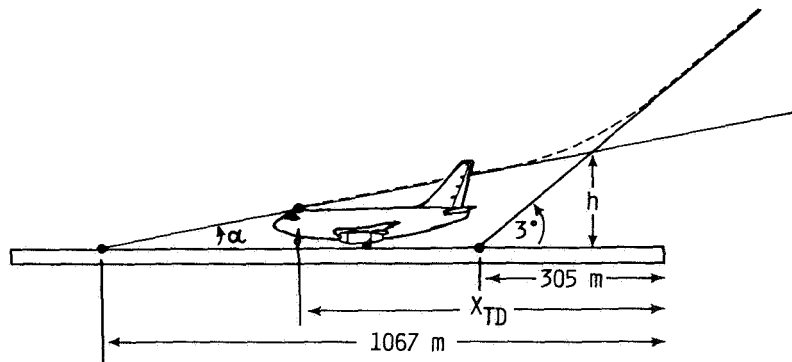

Figure 20.- Example of missed approach vertical MLS coverage.
(Note: 1 ft = 0.3048 m.)



α , deg.	SINK RATE FOR 120 KTS TD, m/s (ft/s)	X_{TD} , m	σ_{TD} , m	h, ft
0.5	0.54 (1.77)	560	149	26
0.6	0.65 (2.12)	645	124	33
0.7	0.75 (2.47)	705	106	40
0.8	0.86 (2.83)	750	93	48

Figure 21.- Alternative method for use of flare guidance system.
(Note: 1 ft = 0.3048 m.)