

IN-FLIGHT DIRECT-STRIKE LIGHTNING RESEARCH

Felix L. Pitts and Mitchell E. Thomas
NASA Langley Research Center

SUMMARY

The NASA Langley Research Center is performing in-flight direct-strike lightning research to better define the lightning-generated electromagnetic environment affecting aircraft. The research program uses an F-106B aircraft which operates in a thunderstorm environment and is specially instrumented for lightning electromagnetic measurements. The instrumentation system is reviewed and typical results recorded by the research instrumentation during simulated-lightning ground tests performed for a safety survey are presented. Several examples of data obtained during the summer of 1980 are presented and future plans are discussed.

INTRODUCTION

The NASA Langley Research Center is performing in-flight direct-strike lightning research using a specially instrumented F-106B aircraft. The intent of this research is to refine the characterization of the lightning-generated electromagnetic environment affecting aircraft. The projected use of digital avionic systems, along with composite aircraft structure, compounds lightning-related problems. Digital avionic systems are potentially more susceptible to upset by electrical transients than previous generation systems and the composite structure may not provide electrical shielding equivalent to that provided by metal aircraft in the past. Future design processes will thus require lightning-protection assessment techniques for digital avionic systems operating in electromagnetically nonoptimum structures. A necessary requirement of potential assessment techniques (which may range from purely analytical, through simulation, to actual hardware tests) is a refined definition of the lightning electromagnetic hazard. Recent discussion and review (ref. 1) supplemented by ground-based measurements (ref. 2) has indicated that the rise times of lightning electromagnetics are around one order of magnitude faster than those used in current lightning-protection criteria.

The intent, rationale, and design goals of the instrumentation system developed at NASA Langley Research Center to aid in-flight lightning-hazard characterization are described in reference 3. The present report contains a review of the actual instrumentation system implementation, presents results recorded by the research instrumentation during simulated lightning testing, which was part of a safety survey of the aircraft, and presents and compares the initial direct-strike lightning data with the simulation data.

INSTRUMENTATION SYSTEM OVERVIEW

The instrumentation concept shown in figure 1 consists of a number of electromagnetic sensors which measure the electromagnetic fields during the lightning process. The data are then recorded in a shielded, isolated instrumentation enclosure. A photograph of the instrumentation system with its cover removed is shown in figure 2. The system is mounted in the missile bay of the F-106B.

Specially expanded Biomation transient waveform recorders (ref. 4), which operate at a 10-nanosecond sample interval and 6-bit resolution, provide a unique capability for recording lightning electromagnetic transients. The basic Biomation Model 6500 recorder memory was increased by over two orders of magnitude to allow a significant data window recording of 1.3 milliseconds of data at 10-nanoseconds resolution. Photographs of the expanded Biomation front panel and the memory expansion are shown in figures 3 and 4. Upon acquisition of strike data by the transient waveform recorder, the data are automatically transferred to the data formatter and thence to the instrumentation recorder for permanent storage. The transient recorder is then automatically reset to acquire data from the next strike.

The wide-band RCA video recorder has 6-MHz bandwidth and is capable of recording continuously for 24 minutes. This continuous recorder is used to provide information on the overall lightning scenario.

The sensors used in the lightning instrumentation system are derived from designs developed for nuclear electromagnetic pulse measurements. (See ref. 5.) The sensors measure the rate of change of strike current to the noseboom (I-Dot) along with the rate of change of electric and magnetic flux density (D-Dot, B-Dot) at a number of locations as shown in figure 5. The sensor response to rates of change of the lightning electromagnetic characteristics (as opposed to the current and fields, directly) accentuates the recording of the higher frequency components of the lightning process. Since the magnitudes of induced voltages (and currents) are proportional to rates of change of the lightning electromagnetic characteristics, enhanced definition of the more interesting (from an induced-effects viewpoint) portion of the spectrum is obtained. The sensor sensitivity is calculated based on sensor geometry (ref. 6) and then checked using a parallel-plate transmission-line calibrator. Figures 6, 7, and 8 are photographs of the I-Dot, B-Dot, and D-Dot sensors, respectively; figure 9 is a photograph of the flat-plate transmission-line calibrator.

Power system isolation for the instrumentation is obtained using a motor-generator set. A 3-phase, 208-V, 400-Hz, 13-kVA electric motor external to the enclosure drives a nonconducting flexible coupler to a 12.5-kVA, 120/208-V, 3-phase, 400-Hz AC generator located within the enclosure to power the system.

The sensor-recorder configuration used in the initial flight configuration is shown in table I, which also summarizes the data channel bandwidths, thresholds, and full-scale values.

SIMULATED LIGHTNING GROUND TEST

A simulated lightning safety survey test was performed on the aircraft to assess potential problems concerning aircraft systems safety. These tests were conducted by Lightning Technologies, Inc., and no safety hazards were disclosed by the tests. The safety survey tests also provided an opportunity for "end-to-end" instrumentation system fidelity and noise immunity tests. The tests were performed with the aircraft engine running and all flight systems operating on aircraft power. The instrumentation system measured and recorded the fields and currents on the aircraft in response to a current pulse of known amplitude and waveform (as determined from an external current transformer measurement) which was generated with a high-voltage capacitor discharge apparatus attached to the noseboom. The current exited from the aircraft tail and was returned to the generator using symmetrical return wires as shown in the test setup photograph of figure 10. During these tests, the instrument system sensitivity was increased by one order of magnitude over the initial flight configuration to accommodate the relatively low capability of the test generator compared with the nominal lightning characteristics assumed for data channel scaling. In addition, the channel assignments were altered as shown in table II to utilize the increased time resolution of the transient recorder for monitoring the I-Dot sensor.

Typical responses of the I-Dot, D-Dot forward, and B-Dot longitudinal sensors are shown in figures 11 to 14. Figure 11 shows I-Dot sensor response to an input current to the noseboom. The input was a damped sinusoidal current oscillating at 86 000 Hz with a peak amplitude of 10 500 amperes. The I-Dot measurement agrees with the rate of change of input current within about 10 percent. Polarity of the I-Dot measurement is negative for conventional current increasing out of the noseboom, as was the case for this test. Figures 12 and 13 show in greater detail the response of the I-Dot and D-Dot forward sensors to the first cycle of input current.

Figure 14 shows the response of the B-Dot sensor to a damped sinusoidal input current to the aircraft noseboom. The input was a damped sinusoidal current oscillating at 86 000 Hz with a peak amplitude of 14 250 amperes. The magnitude of the B-Dot measurement is about 35 percent of the amplitude calculated for this input current to a simple cylinder with a radius of 1 meter (approximate fuselage radius). The presence of the aircraft wing alters the magnetic field which would be obtained from a simple cylinder. The relative position of the return wires causes intensification of current in the wing, thereby reducing the field at the location of the B-Dot sensor.

During subsequent tests, sensor cables were terminated in dummy 50-ohm loads, in lieu of the sensors, to investigate the noise immunity of the instrumentation system. The system did not respond during these tests, which indicates that the noise level would be at least one order of magnitude below the flight configuration threshold.

LIGHTNING DATA

The aircraft sustained three strikes while in the vicinity of the National Severe Storms Laboratory, Norman, Oklahoma, on June 17, 1980. The strikes occurred with the aircraft at an altitude of 4800 meters at a speed of 300 knots; the approximate freezing level was at the aircraft operating altitude. The detailed waveforms of these strikes were reported in reference 7; these strikes were not particularly energetic in that the magnetic characteristics (I-Dot, B-Dot) did not exceed system thresholds, and only information from the forward D-Dot sensor was recorded. The portions of the preceding strike data records with the largest rates of change of electric flux density are shown in figures 15 and 16.

The aircraft was struck a total of ten times during the 1980 campaign with five of these occurring in rapid succession during one flight on September 3, 1980. Data processing, interpretation and analysis of the data are continuing; the following observations are offered at this point: (1) the utility of the derivative (D-Dot) sensor is clearly demonstrated by examining the amplitude resolution of the "faster" changing portions of figures 15 and 16 during the first microsecond of the event; and (2) the data indicate significant changes in the strike electric characteristics during submicrosecond intervals.

FUTURE PLANS

The capability of the recording system is being significantly increased. A new transient recorder with 12 data channels of similar characteristics to the expanded Biomation transient recorder is being obtained as is an analog video recorder with a 15-MHz bandwidth. This increased capability will allow a much more complete characterization of the lightning-generated electromagnetic environment.

Upon acquisition of a statistically significant data base for strike characterization (which is not near at hand), considerable effort will be required to assess the significance and interpret the data as concerns future aircraft designs.

REFERENCES

1. Clifford, Don W.; Krider, E. Philip; and Uman, Martin A.: A Case for Submicrosecond Rise-Time Lightning Current Pulses for Use in Aircraft Induced Coupling Studies. 1979 IEEE International Symposium on Electromagnetic Compatibility. San Diego, Calif., Oct. 9-11, 1979, pp. 143-149.
2. Weidman, C. D.; and Krider, E. P.: Submicrosecond Risetimes in Lightning Radiation Fields. Lightning Technology, NASA CP-2128, 1980, pp. 29-38.
3. Pitts, F. L., et al.: In-Flight Lightning Characteristics Measurement System. Federal Aviation Administration - Florida Institute of Technology Workshop on Grounding and Lightning Technology, FAA-RD-79-6, Mar. 1979, pp. 105-111.
4. Thomas, Robert M., Jr.: Expanded Interleaved Solid-State Memory for a Wide Bandwidth Transient Waveform Recorder. Lightning Technology, NASA CP-2128, 1980, pp. 119-129.
5. Baum, C. E., et al.: Sensors for Electromagnetic Pulse Measurements Both Inside and Away from Nuclear Source Regions. IEEE Trans. Electromagn. Compat., vol. EMC-20, no. 1, Feb. 1978.
6. Trost, Thomas F.; and Zaepfel, Klaus P.: Broadband Electromagnetic Sensors for Aircraft Lightning Research. Lightning Technology, NASA CP-2128, 1980, pp. 131-152.
7. Pitts, Felix L.; and Thomas, Mitchel E.: Initial Direct Strike Lightning Data. NASA TM-81867, 1980.

TABLE I. - INITIAL FLIGHT CONFIGURATION

Sensor	Recorder	Sample Rate (Bandwidth)	P-P Full Scale	Threshold
\dot{D} Forward	Transient	100 MHz (50* MHz)	$\pm 24.5 \text{ A/m}^2$	$+4.9 \text{ A/m}^2$
\dot{B} Longitudinal	Transient	100 MHz (50* MHz)	$\pm 8695 \text{ T/s}$	$+1739 \text{ T/s}$
\dot{D} Right Wing	Wide-band Analog	(6 MHz)	$\pm 28 \text{ A/m}^2$	$\pm 2.8 \text{ A/m}^2$
\dot{i}	Wide-band Analog	(6 MHz)	$\pm 4.7 \times 10^{10} \text{ A/s}$	$\pm 4.7 \times 10^9 \text{ A/s}$

*Four-pole linear phase low pass filter 3 db point at 50 MHz.

TABLE II. - GROUND TEST CONFIGURATION

Sensor	Recorder	Sample Rate (Bandwidth)	P-P Full Scale	Threshold
\dot{D} Forward	Transient	100 MHz (50* MHz)	$\pm 2.45 \text{ A/m}^2$	$+0.49 \text{ A/m}^2$
\dot{B} Longitudinal	Wide-band Analog	(6 MHz)	$\pm 870 \text{ T/s}$	$\pm 87 \text{ T/s}$
\dot{D} Tail	Wide-band Analog	(6 MHz)	$\pm 2.45 \text{ A/m}^2$	$\pm .245 \text{ A/m}^2$
\dot{i}	Transient	100 MHz (50* MHz)	$\pm 4.7 \times 10^9 \text{ A/s}$	$+0.94 \times 10^9 \text{ A/s}$

*Four-pole linear phase low pass filter 3 db point at 50 MHz.

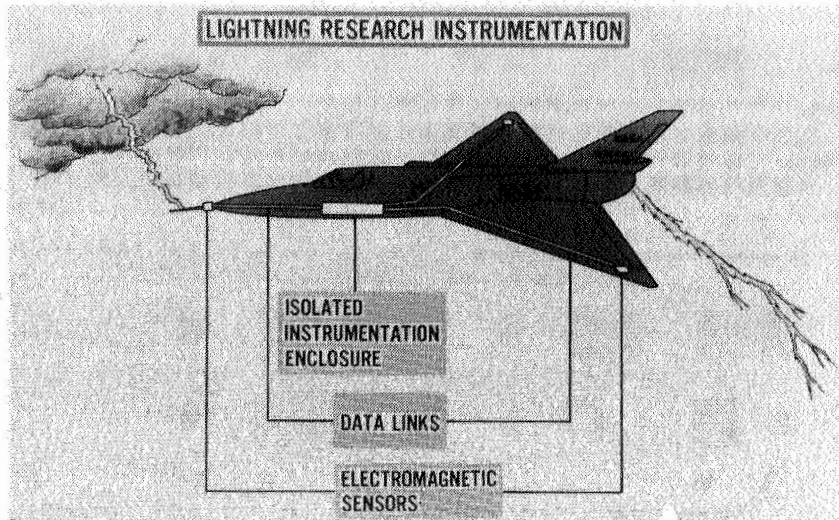

Figure 1.- Instrumentation system concept.

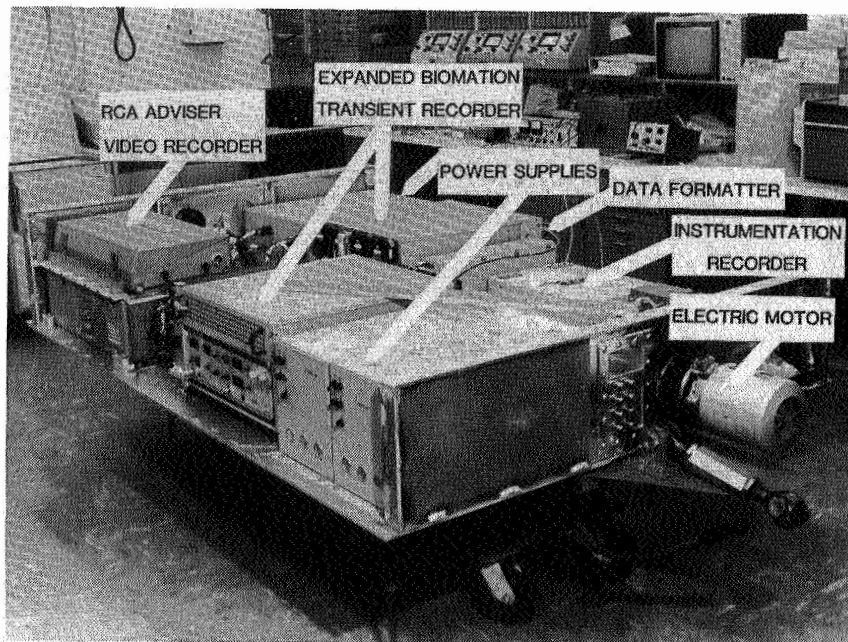

Figure 2.- Instrumentation system.

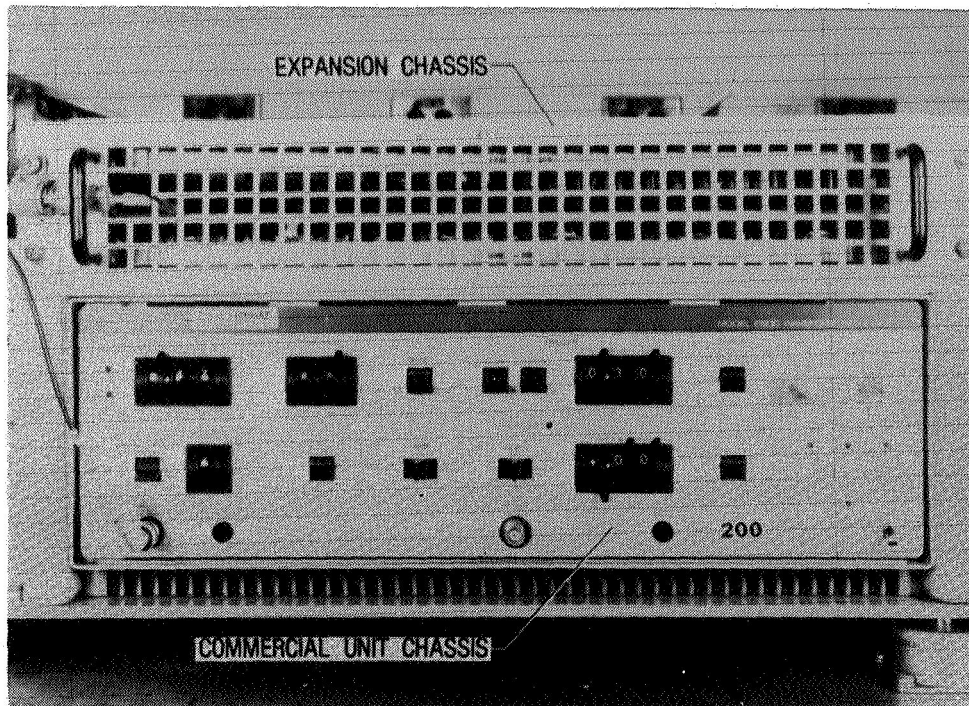

Figure 3.- Expanded waveform recorder.

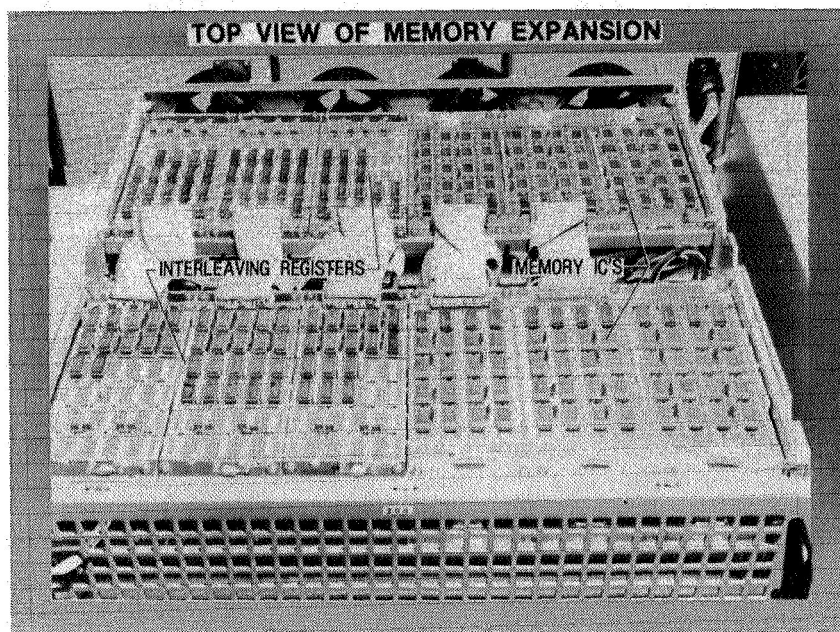

Figure 4.- Expanded memory.

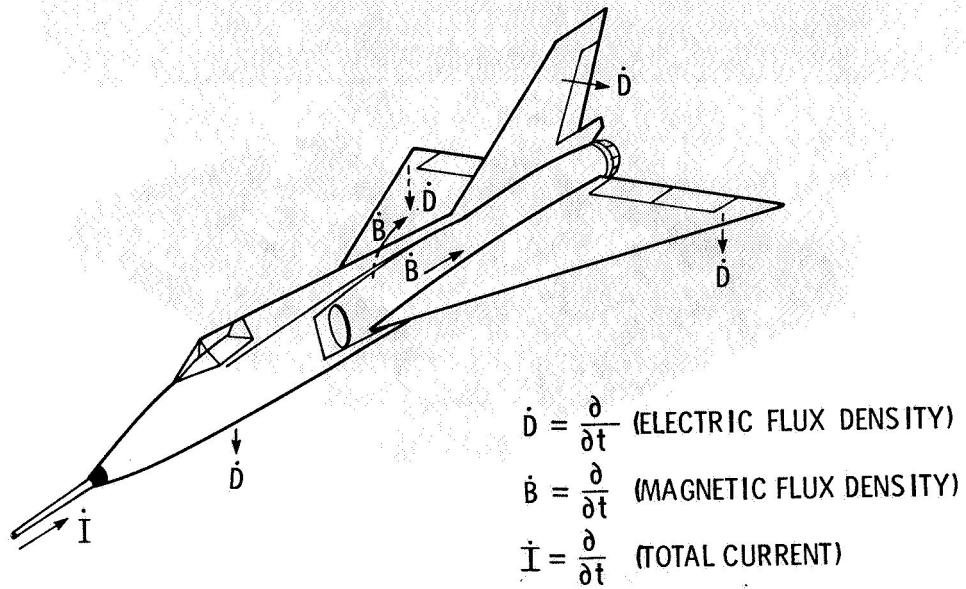

Figure 5.- Sensor locations.

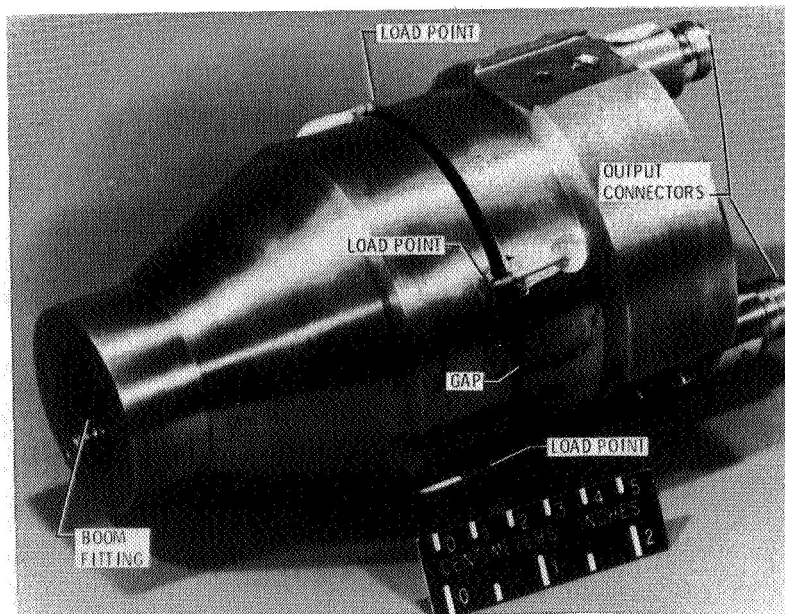

Figure 6.- I-Dot sensor.

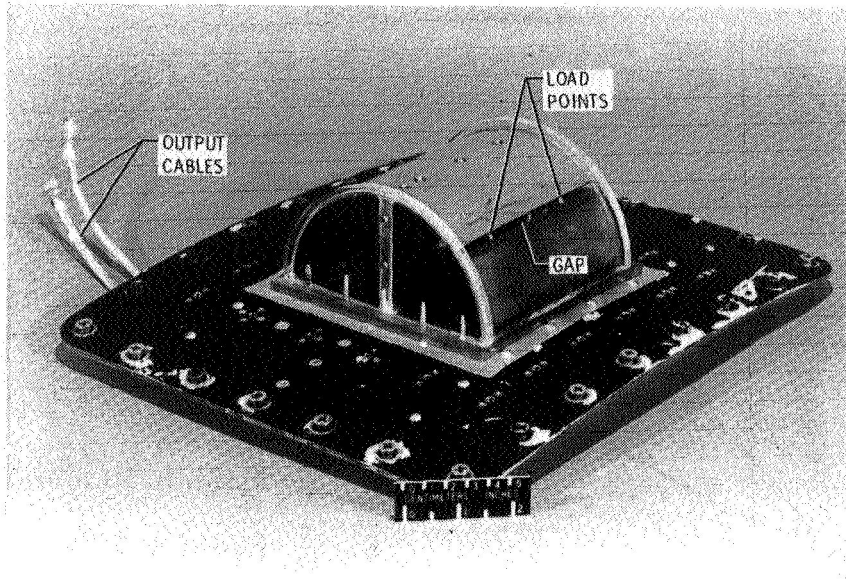

Figure 7.- B-Dot sensor.

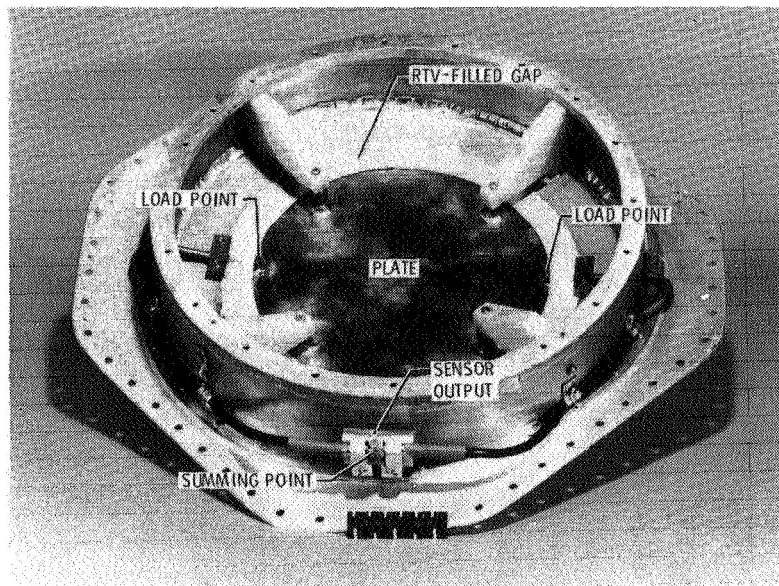

Figure 8.- D-Dot sensor.

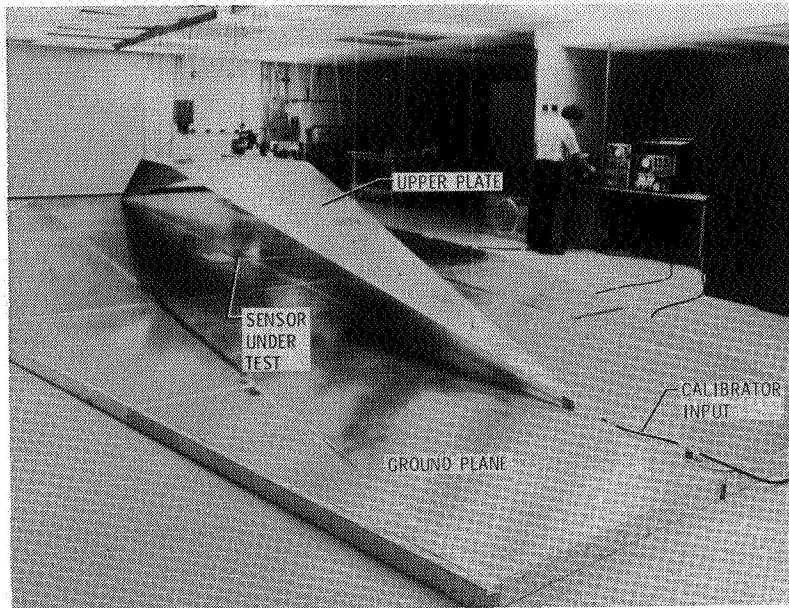

Figure 9.- Flat-plate transmission-line calibrator.

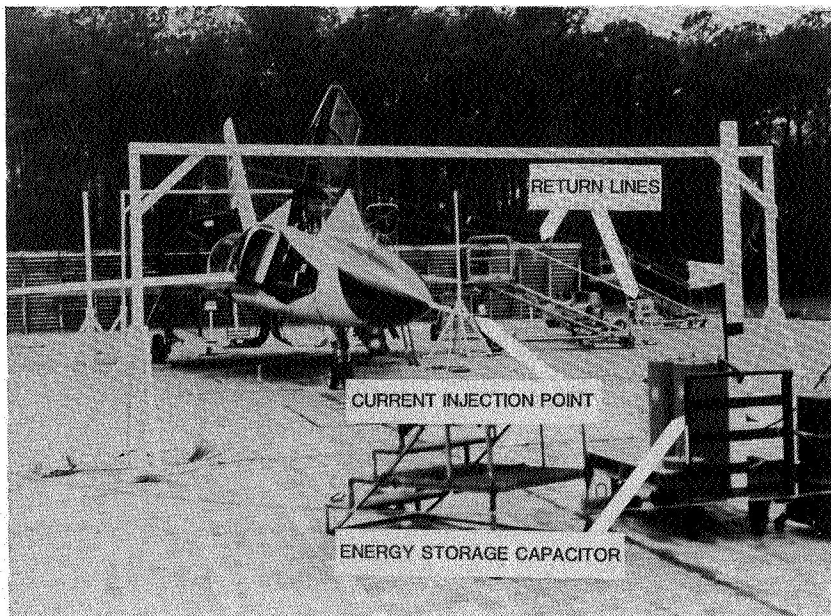

Figure 10.- Simulated lightning ground test.

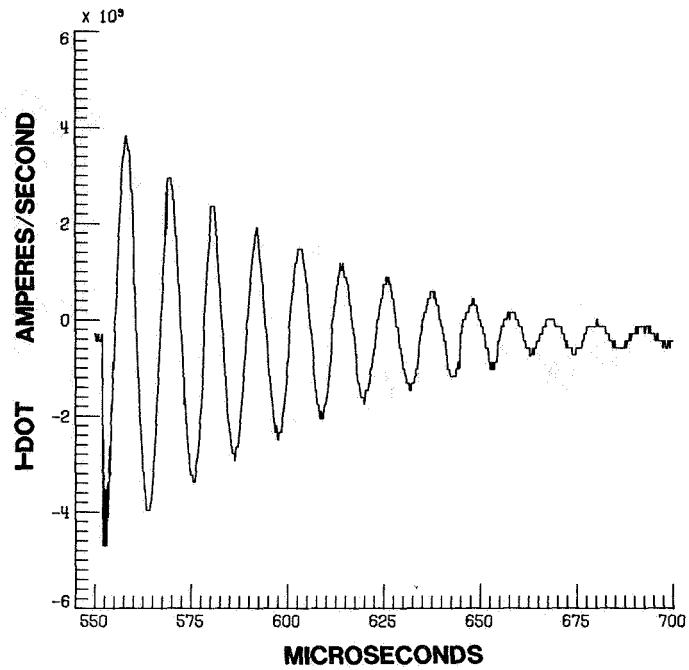

Figure 11.- I-Dot sensor response.

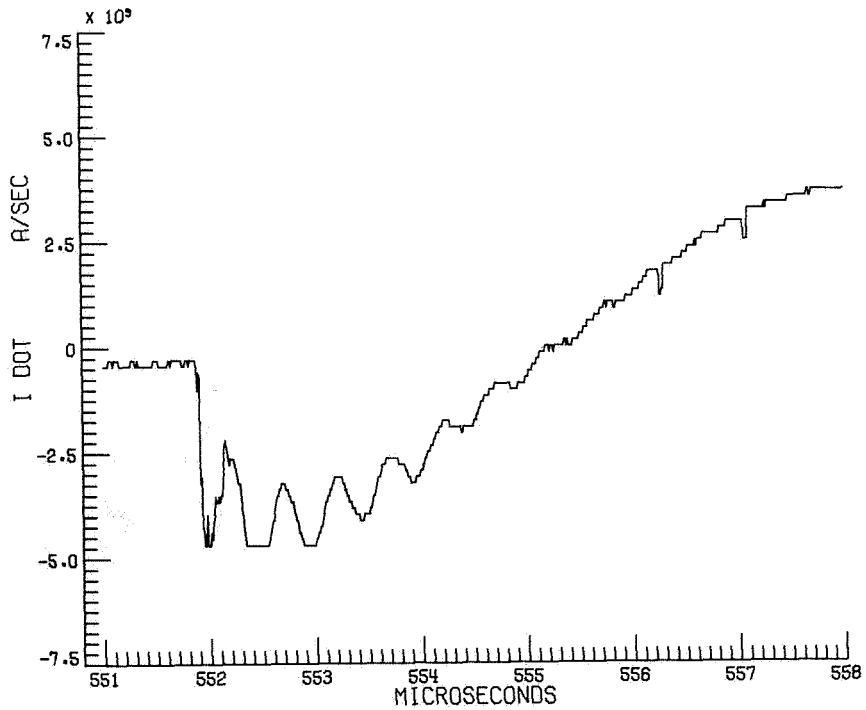

Figure 12.- I-Dot sensor response, expanded time scale.

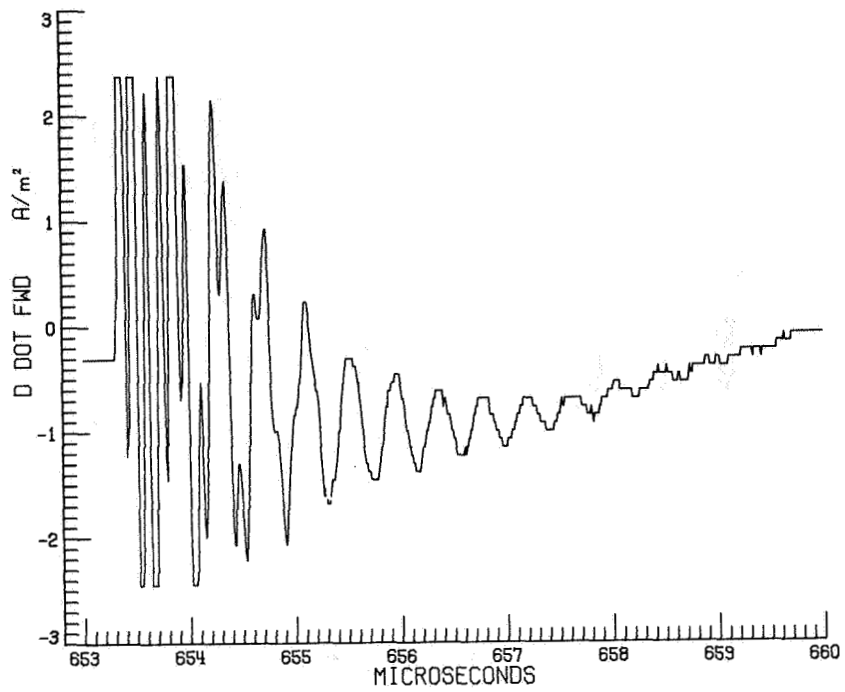

Figure 13.- D-Dot sensor response.

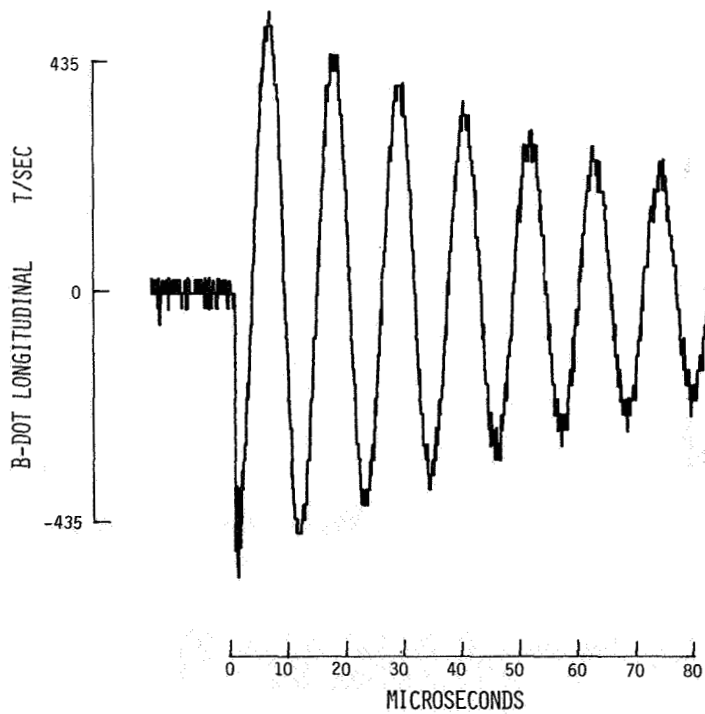

Figure 14.- B-Dot sensor response.

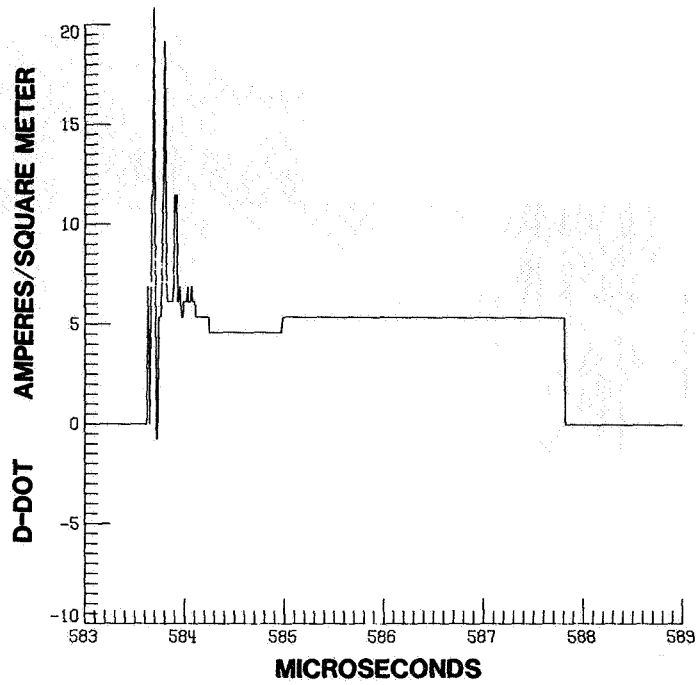

Figure 15.- Direct-strike D-Dot record A.

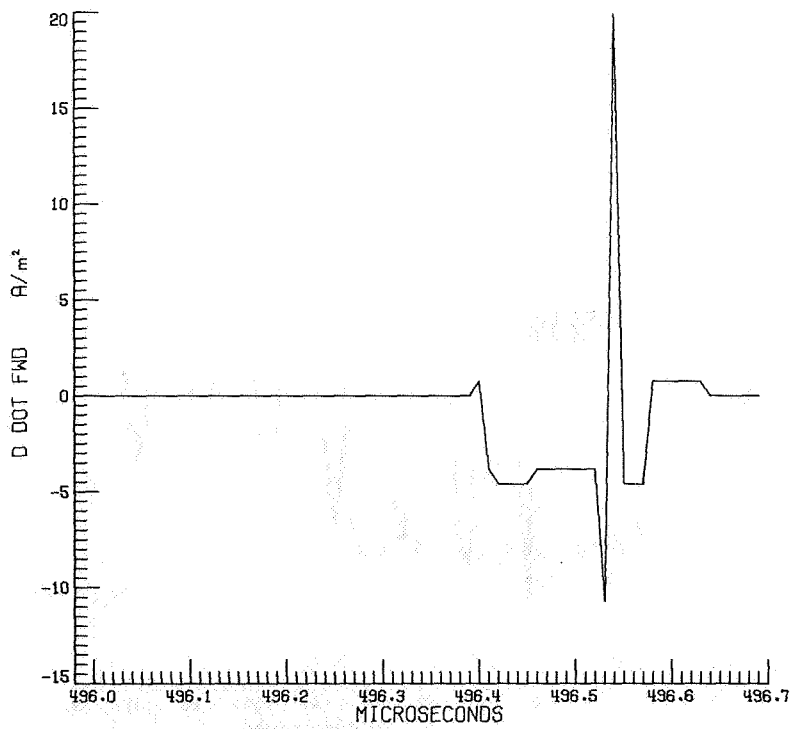

Figure 16.- Direct-strike D-Dot record B.